

PB2001-108576



RESEARCH REPORT 3970-S

PILOT INSTALLATION OF A BRIDGE SCOUR MONITORING SITE AT FM 1157 MUSTANG CREEK

José Weissmann, Huong Tung Chun, and Carl Haas

CENTER FOR TRANSPORTATION RESEARCH
BUREAU OF ENGINEERING RESEARCH
THE UNIVERSITY OF TEXAS AT AUSTIN

DECEMBER 1999

REPRODUCED BY:
U.S. Department of Commerce
National Technical Information Service
Springfield, Virginia 22161

NTIS



1. Report No. 3970-S	2. Government Accession No.	3. Recipient's Catalog No.	
4. Title and Subtitle PILOT INSTALLATION OF A BRIDGE SCOUR MONITORING SITE AT FM 1157 MUSTANG CREEK		5. Report Date December 1999	
7. Author(s) José Weissmann, Huong Tung Chun, and Carl Haas		6. Performing Organization Code	
		8. Performing Organization Report No. 3970-S	
9. Performing Organizations' Names and Addresses University of Texas at San Antonio Division of Engineering 6900 North Loop 1604 West San Antonio, TX 78249-0665 Center for Transportation Research The University of Texas at Austin 3208 Red River, Suite 200 Austin, TX 78705-2650		10. Work Unit No. (TRAIS)	
		11. Contract or Grant No. 7-3970	
12. Sponsoring Agency Name and Address Texas Department of Transportation Research and Technology Transfer Section/Construction Division P.O. Box 5080 Austin, TX 78763-5080		13. Type of Report and Period Covered Project Summary Report (9/99-12/99)	
		14. Sponsoring Agency Code	
15. Supplementary Notes Project conducted in cooperation with the Federal Highway Administration.			
16. Abstract A pilot installation was implemented at the Mustang Creek bridge crossing on FM 1157 in the Yoakum District, Jackson County, Texas. This pilot installation was developed in two phases. Phase I used a rather limited datalogger that lacked the ability to monitor hybrid sensor sites involving ultrasonic and magnetic sliding-collar sensors. Neither could it generate alarm calls to an office computer. The Phase I installation consisted of four ultrasonic sensors mounted on four different bridge piers. Researchers had access to the scour and stage data remotely through a cellular phone and modem installed at the site. The site was powered by a battery and solar panel installation. The Phase II installation utilized a more powerful datalogger at the Mustang Creek site using the same ultrasonic sensors and sensor assemblies installed during Phase I. Phase II also installed an improved combination of cellular telephone and modem, which significantly improved communications with the site. The Phase II datalogger has the ability to monitor multiple and varied types of sensors, such as pressure transducers for stage and ultrasonic and magnetic sliding-collar sensors for scour. This is a fully programmable datalogger that has the ability to generate alarm calls to an office computer when certain preprogrammed thresholds for stage and scour are reached. Automatic paging software residing in an office computer generates alarm calls to alphanumeric pagers carried by TxDOT maintenance staff, based on alarm call backs from the datalogger in the field.			
17. Key Words Bridge scour, scour monitoring		18. Distribution Statement No restrictions. This document is available to the public through the National Technical Information Service, Springfield, Virginia 22161.	
19. Security Classif. (of report) Unclassified	20. Security Classif. (of this page) Unclassified	21. No. of pages 136	22. Price

**PILOT INSTALLATION OF A BRIDGE SCOUR MONITORING SITE AT FM 1157
MUSTANG CREEK**

by

José Weissmann
Huong Tung Chun
Carl Haas

Project Summary Report Number 3970-S

Research Project 7-3970

Project Title: Infrastructure for a Statewide Scour and Road-Submergence Warning System

Conducted for the

TEXAS DEPARTMENT OF TRANSPORTATION

by the

UNIVERSITY OF TEXAS AT SAN ANTONIO

and the

CENTER FOR TRANSPORTATION RESEARCH

Bureau of Engineering Research

THE UNIVERSITY OF TEXAS AT AUSTIN

December 1999

IMPLEMENTATION AND RECOMMENDATIONS FOR FUTURE RESEARCH

1. The hardware and software combination developed in this research project can be easily adapted for the monitoring of low-water crossings. Almost exactly the same hardware and software set up, with a redesigned pressure transducer assembly, can be used at low-water crossing to monitor water levels and to generate pager alarms when certain thresholds are reached. The datalogger identified and tested by this research project has also the capability of controlling flashing beacons at low-water crossings, and even of operating physical barriers to the traffic automatically when preprogrammed water level thresholds are reached. This low-water crossing set up should be tested at pilot sites, with such testing also serving as implementation for concluded Project 0-1380, "Develop a Remote Automatic Monitoring and Public Information System for Hazardous Conditions."
2. Information obtained from multiple scour monitoring sites and low-water crossing sites can be easily integrated by an office computer server and even published on the Internet using the appropriate combination of hardware and software.
3. This research project specified and tested the basic hardware and software for monitoring scour remotely at bridge sites. However, it is recommended that additional scour monitoring sites be implemented, with such sites allowing for field testing of an automatic magnetic sliding collar installation, which was not tested at this research project's pilot site.
4. Larger bridges — those with extremely high piers — may translate into more challenging installations as a result of the technical limits on wiring lengths for data transmission from the sensors to the datalogger. These larger bridges can be monitored for scour using a system of wireless local radio connections at the site, connecting the sensors and the site's datalogger. These types of situations should be tested at additional sites to assess their feasibility.
5. The scour monitoring prioritization system documented in Report 3970-1 should be implemented as a tool for setting priorities for the installation of scour monitoring systems.

DISCLAIMERS

The contents of this report reflect the views of the authors, who are responsible for the facts and the accuracy of the data presented herein. The contents do not necessarily reflect the official views or policies of the Texas Department of Transportation. This report does not constitute a standard, specification, or regulation.

There was no invention or discovery conceived or first actually reduced to practice in the course of or under this contract, including any art, method, process, machine, manufacture,

design or composition of matter, or any new and useful improvement thereof, or any variety of plant, which is or may be patentable under the patent laws of the United States of America or any foreign country.

**NOT INTENDED FOR CONSTRUCTION,
BIDDING, OR PERMIT PURPOSES**

José Weissmann, P.E. (Texas No.79815)
Research Supervisor

ACKNOWLEDGMENTS

The project staff would like to acknowledge the help and guidance of the project director, Anthony (Tony) Schneider, P.E., in the development of this research project. Also appreciated is the pilot scour monitoring installation support we received from Gerald Freytag, P.E., of the Yoakum District.

Research performed in cooperation with the Texas Department of Transportation.

TABLE OF CONTENTS

CHAPTER 1. INTRODUCTION.....	1
CHAPTER 2. DESCRIPTION OF THE HARDWARE AND SOFTWARE USED IN PHASE I OF THE PILOT SCOUT MONITORING SITE	5
CHAPTER 3. DESCRIPTION OF THE HARDWARE AND SOFTWARE USED IN PHASE II OF THE PILOT SCOUR MONITORING SITE.....	39
CHAPTER 4. SUMMARY AND RECOMMENDATIONS FOR FURTHER RESEARCH.....	71
APPENDIX A. Solar Panel and Battery Selection for the Phase I Installation	73
APPENDIX B. Phase I Datalogger Menus	79
APPENDIX C. Phase I Cost Information.....	85
APPENDIX D. Solar Panel and Battery Selection for the Phase II Installation	89
APPENDIX E. Commented Software Code for the CR10X Datalogger Installed at the Mustang Creek Site	93
APPENDIX F. Software Code for the CR10X Datalogger for Monitoring a Reed Switch Assembly.....	121

**PROTECTED UNDER INTERNATIONAL COPYRIGHT
ALL RIGHTS RESERVED
NATIONAL TECHNICAL INFORMATION SERVICE
U.S. DEPARTMENT OF COMMERCE**

Reproduced from
best available copy. 

CHAPTER 1. INTRODUCTION

This report documents the scour monitoring system installed at the Mustang Creek bridge crossing on FM 1157 in the Yoakum District, Jackson County, Texas. The initial field installation was carried out from August 19–20, 1998, through the joint effort of a team that included Texas Department of Transportation (TxDOT) and University of Texas at San Antonio (UTSA) personnel. The UTSA team returned to the site on several occasions to implement repairs and upgrades in the system. The installation at the Mustang Creek site can be subdivided into two major phases. In the initial phase, a rather primitive datalogger was installed at the site; it did not have the ability to generate alarms or support multiple sensors (such as combined ultrasonic and sliding-collar devices). In the second phase a more elaborate datalogger was installed at the site, one that was able to generate alarm calls and monitor multiple and diverse sensor types.

According to the TxDOT maintenance engineer for the Yoakum District, the speed of the flowing water in Mustang Creek increases rapidly during rainy seasons. Fast-moving water can erode finely graded riverbeds to dangerous levels in a very short time. A bridge collapse may occur if the riverbed erodes below a certain threshold level, exposing the bridge foundations sufficiently. This specific bridge has a pile foundation that can be particularly vulnerable to scour; it is constructed of piles that are driven into the silt creek bed and topped with concrete piers.

The bridge at Mustang Creek is currently being remotely monitored by a water-level scour monitoring system installed during Project 3970 as a pilot installation. The system consists of the following main elements: four ultrasonic sensors, a sensor for measuring the creek's stage, a cellular phone combined with a modem for remote data retrieval, a datalogger, a battery, and two solar panels. In the second phase of the pilot installation, a more elaborate datalogger and an improved cellular phone and modem were installed. These will be discussed in the following chapters.

SITE SURVEY

In the early summer of 1998, the UTSA staff, together with the TxDOT district maintenance engineer, performed the initial survey of the bridge. The objective of this initial

survey was to study where the critical water flow was located and which foundations were to be monitored. In addition, a survey was made to locate the storage box for the datalogger and power systems. The layout of the proposed scour monitoring facility is shown in Figures 1.1 and 1.2. All the measurements displayed in the figures were actually established at the time of the installation, which is documented in subsequent chapters. Some of the measurements were dependent on the water level and were left for the actual day of installation. However, some of the coordinates displayed in Figures 1.1 and 1.2 provide a good summary of the situation at the site during the planning phase.

Ultrasonic sensors were planned for installation at piers #3, #4, #5, #6, with the creek stage transducer installed at pier #4. A scour depth monitoring unit, to be discussed later in the report, was planned for attachment to the side of the bridge deck between pier #4 and pier #5.

A wooden pole, to which would be attached the control box containing the datalogger, battery, cellular phone, and modem, as well as the solar panels, was located 50 ft away from the end of the bridge, toward the city of Ganado, and 26 ft away from the center line of FM 1157. Location of the pole and the box was driven by traffic safety requirements.

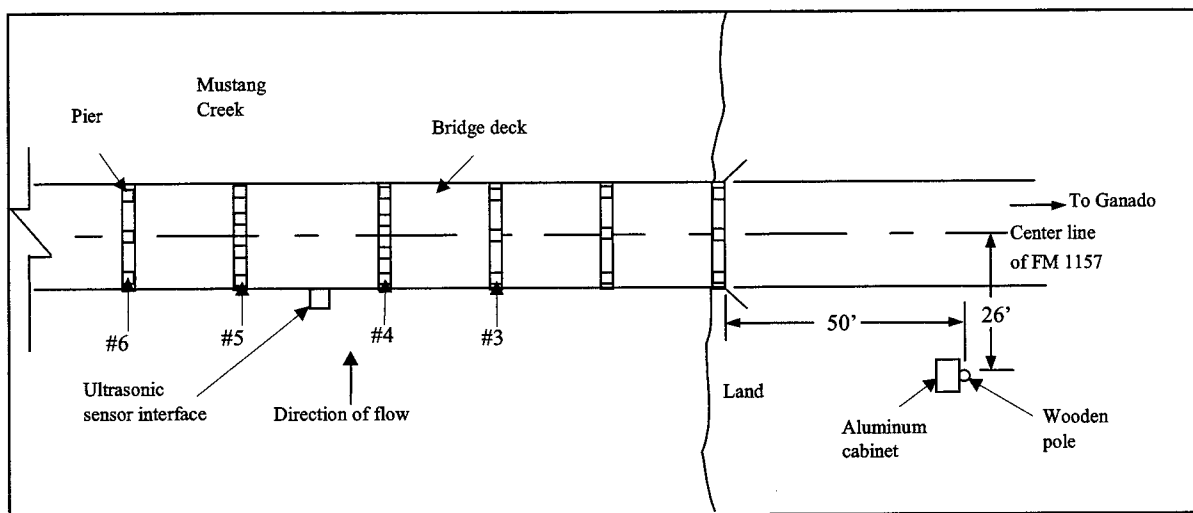

Figure 1.1 Plan view of the proposed installation

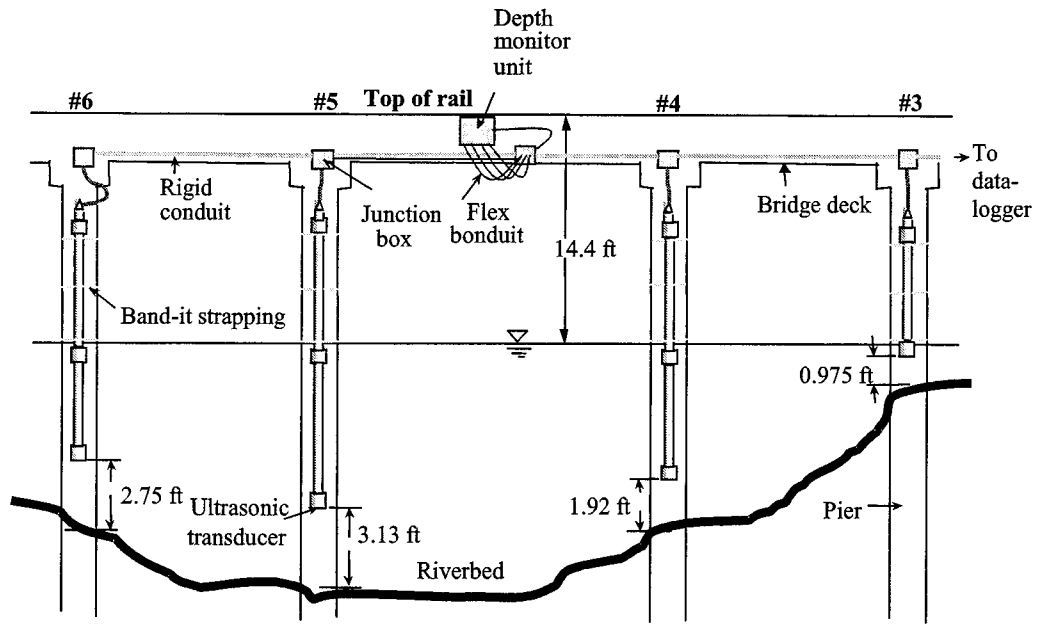

Figure 1.2 Elevation of the proposed installation viewed from upstream.

During this field trip, the distance from the top of the bridge rail to the water surface was also measured. This distance was an important input for fabricating the serviceable sensor-protection housing and attachment. The sensor attachments will be discussed in a subsequent chapter.

CHAPTER 2. DESCRIPTION OF THE HARDWARE AND SOFTWARE USED IN PHASE I OF THE PILOT SCOUR MONITORING SITE

INTRODUCTION

The installation of the Phase I pilot scour monitoring site at the Mustang Creek location is based on an ultrasonic sensor monitoring technology. Schematics of the Phase I installation are depicted in Figure 2.1. Ultrasonic sensors work by receiving a command from the datalogger via the depth monitor unit (H-240), then emitting an ultrasonic wave that hits the riverbed and bounces back to the ultrasonic sensor. Using the time traveled and the speed of the ultrasonic wave, the H-240 unit automatically calculates the distance between the sensor and the riverbed. The H-240 unit has four terminals. Each terminal is used for connecting one ultrasonic sensor. The H-240 unit also converts the ultrasonic sensor digital output into SDI-12, a data transmission protocol adopted by the United States Geological Survey (USGS), and transmits the data stream to the datalogger. This interface allows the H-350 datalogger unit to log the data from the CD400. The H-240 unit always stays in low power mode to reduce the power consumption, unless a reading is requested.

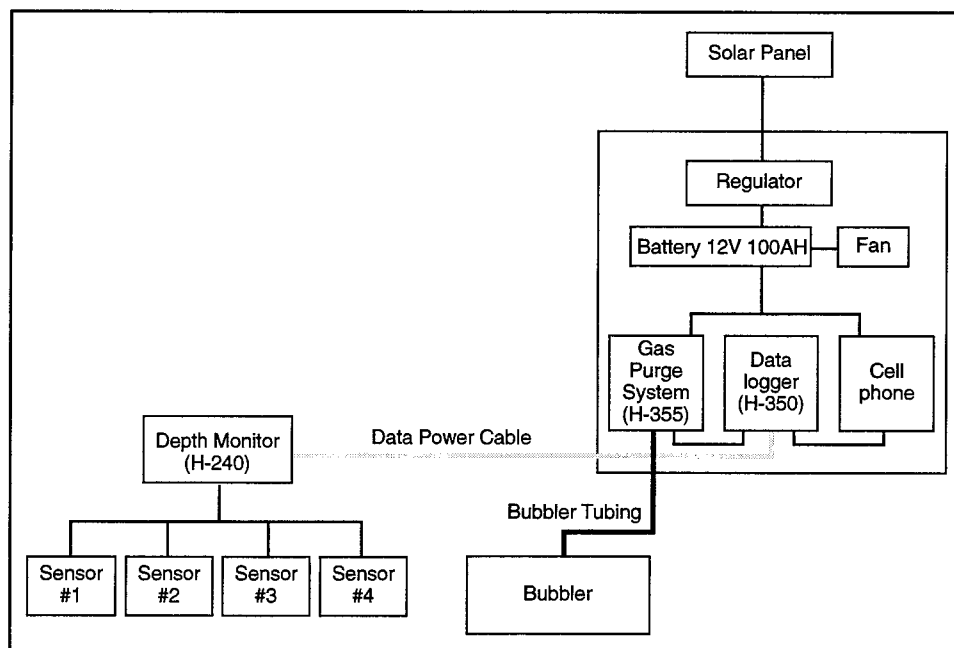

Figure 2.1 Schematics of the Phase I installation

In the Phase I installation, a bubbler unit associated with a “Smart Gas” system (H-355) was used to measure the river stage. The H-355 unit uses a compressor to maintain pressure in an internal tank. It receives the command from the datalogger and, under microprocessor control, determines how much pressure is needed in the tank, based on the current water head pressure, to produce a constant bubble rate. The pressure head measured at the orifice is then sent to the datalogger using an SDI-12 protocol of data transmission. The datalogger multiplies the pressure measured by a factor (this factor is the reciprocal of the unit weight of water), and the result is the depth of water above the orifice.

A cellular phone (Mitsubishi model 300) with a built-in data modem was attached to the serial port of the datalogger. With this arrangement, a maintenance engineer can dial in and download the data stored in the datalogger. Some of the settings, such as the time interval of taking a reading and formatting the flash memory card in the datalogger, are accessible from a reduced menu available at connection time.

The datalogger (H-350) is the brain of the entire system. It can be programmed to carry out its task and to store the readings in its memory. It has a 1 megabyte flash card memory, parallel printer port, RS-232 serial port, pressure input port, pressure reference port, battery SDI-12 port, and auxiliary output.

Solar panels are used in the installation to recharge the battery used to provide electricity to the system. The generated electricity is regulated and stored in a gel-cell battery. For the procedural details of solar panel selection, please refer to Appendix A.

All the electronics of this system are powered by a gel-cell marine battery. A gel-cell battery was selected instead of a lead-acid battery because lead-acid batteries may generate corrosive fumes that may corrode and damage the electronics inside the aluminum box used to store the datalogger, phone modem, and other sensitive electronic devices. For information about battery sizing and selection, please refer to Appendix A.

The aluminum cabinet selected for storing the installed components is lightweight, lockable, and corrosion resistant. It is used for storing the H-355, H-350, cellular phone, battery, and regulator. The cabinet is well ventilated and has an electric fan controlled by a thermostat that controls the internal temperature, keeping it below the operating temperatures for the several electronic devices installed inside the box.

All the electronic devices installed in Phase I operate at temperatures that range from -25 °C to 60 °C.

While all four ultrasonic sensors were manufactured by Data Marine, they were rewired and refitted by Design Analysis Associates, Inc., of Logan, Utah¹. The H-240, H-350, and H-355 units were developed and manufactured by Design Analysis Associates. All other components were purchased locally from hardware stores and plumbing suppliers. The UTSA Project 3970 staff assembled all the components and, together with a TxDOT crew, participated actively in the installation.

TESTING OF THE EQUIPMENT

Before installation at the Mustang Creek site, all the items mentioned in the previous session were tested to ensure their reliability and their accuracy. Most of the equipment associated with a water-level scour monitoring system was tested twice, once in a laboratory environment and a second time in a field test. The field tests were carried out at the San Antonio River in Brackenridge Park in the city of San Antonio, Texas.

Testing at the San Antonio River

During the testing at the San Antonio River, the system was powered by the selected gel-cell battery, and the solar panel was attached briefly to test its ability to recharge the battery. The four ultrasonic sensors were attached to a 10 ft, 2 in.-diameter PVC pipe, as shown in Figure 2.2, and tested one at a time. All the measurements were obtained by immersing the ultrasonic assembly into the river. The total depth of the water from the center of the pedestrian bridge used as the testing platform was measured with a long, scaled stick.

After the total depth of the water was determined with the graduated stick, the assembly shown in Figure 2.2 was lowered into the water and the level on the scaled assembly was read. The actual distance between the sensor and the riverbed is the total depth measured by the scaled stick, minus the level read from the scale marked on the PVC pipe holding the ultrasonic sensor.

¹ Design Analysis Associates, Inc., 75 West 100 South, Logan, UT, 84321, phone (435) 753-2212

The same test, but with different depths, was repeated several times to compare the ultrasonic sensor readouts with the actual distance between the sensor head and the bottom of the river.

From the tests, the researchers found that the ultrasonic sensor (H-240) readouts were consistently 0.2 ft higher when compared to the actual distance between the sensor and the riverbed. This is an acceptable error for monitoring bridge scour.

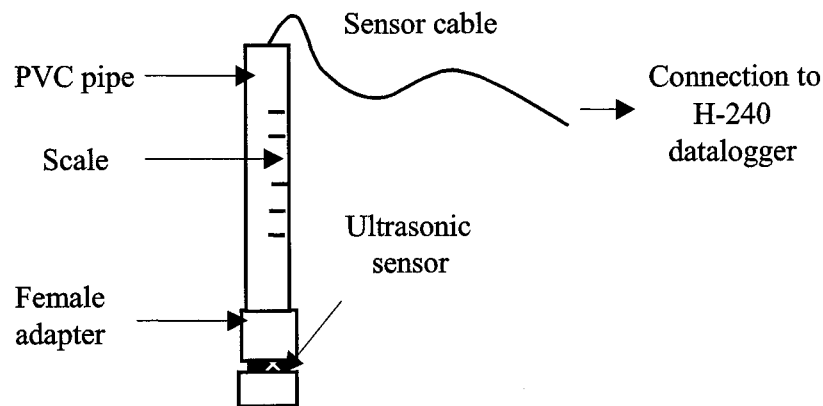

Figure 2.2 Temporary ultrasonic sensor assembly

In the bubbler (water level transducer) test, the assembly shown in Figure 2.3 was lowered into the water. After that, the level on the scale on the PVC pipe was read and compared with the values acquired by the datalogger and transmitted by the H-350 unit. These steps were repeated for several different depths.

From the test, Project 3970 researchers determined that the water level readings measured by the bubbler (H-350 unit) were very close to the actual water levels read from the scaled PVC pipe. The errors of the readings were less than 0.1 ft. This finding supported the conclusion that the bubbler unit is reliable.

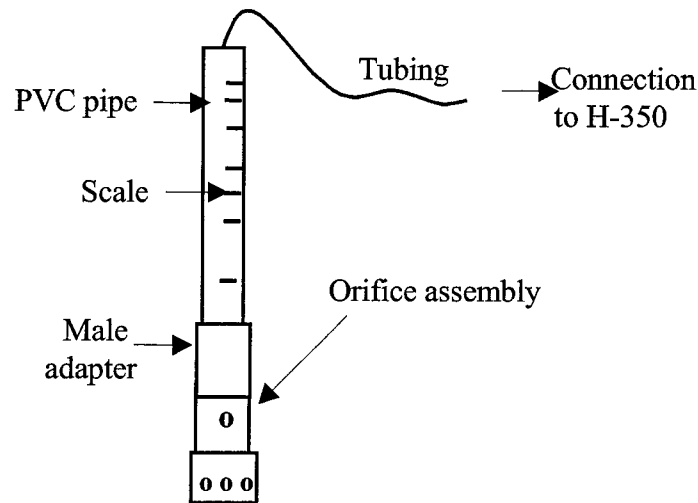

Figure 2.3 Temporary bubbler orifice assembly

PREFABRICATION OF ELECTRONICS ENCLOSURE AND SENSOR ASSEMBLY

This section will cover the procedures of prefabrication of the electronics enclosure and the sensor assembly. Many items needed to be fabricated before they were moved to the installation site.

For an electronics enclosure, an aluminum cabinet is preferable to a steel cabinet because aluminum is much lighter and more resistant to corrosion. The aluminum cabinet may be purchased from highway product suppliers or electrical supply companies. The price for a 30 in. x 50 in. x 18 in. aluminum cabinet required for the installation is close to \$1,000. For this specific installation, a used cabinet was obtained from TxDOT. (This box was previously used to house a traffic controller within the Yoakum District and was retrofitted to house the electronics for the scour monitoring system installed at the Mustang Creek location.)

A D.C. fan, controlled by a thermostat, was installed at the top of the cabinet to ensure that the internal temperature would not exceed the limits established for the electronic devices installed inside the box.

Most of the parts of the sensor assembly were prefabricated in the laboratory using standard off-the-shelf PVC tubing and fittings. The main advantage of prefabrication is to saving substantial field crew time and field equipment rental time.

Prefabrication of Back Plate and Aluminum Cabinet

Figure 2.4 summarizes the dimensions of the aluminum box housing. Figure 2.5 depicts the layout of the different units housed inside the box and some of the connections. This figure depicts the datalogger (H-350), bubbler unit (H-355), Mitsubishi cellular phone and modem assembly, battery, solar panel voltage regulator, and fan.

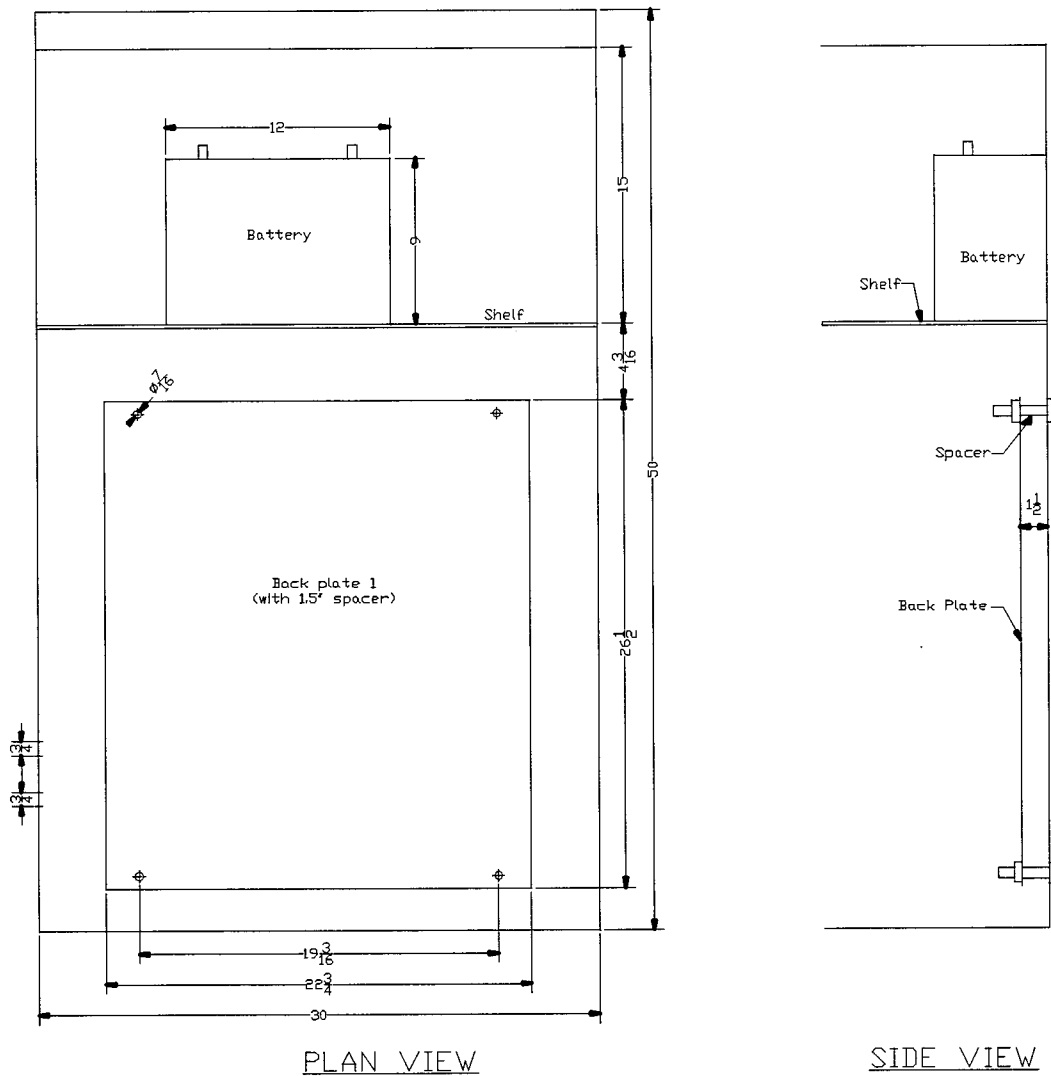

Figure 2.4 Plan and side views for the main electronics box (dimensions in inches)

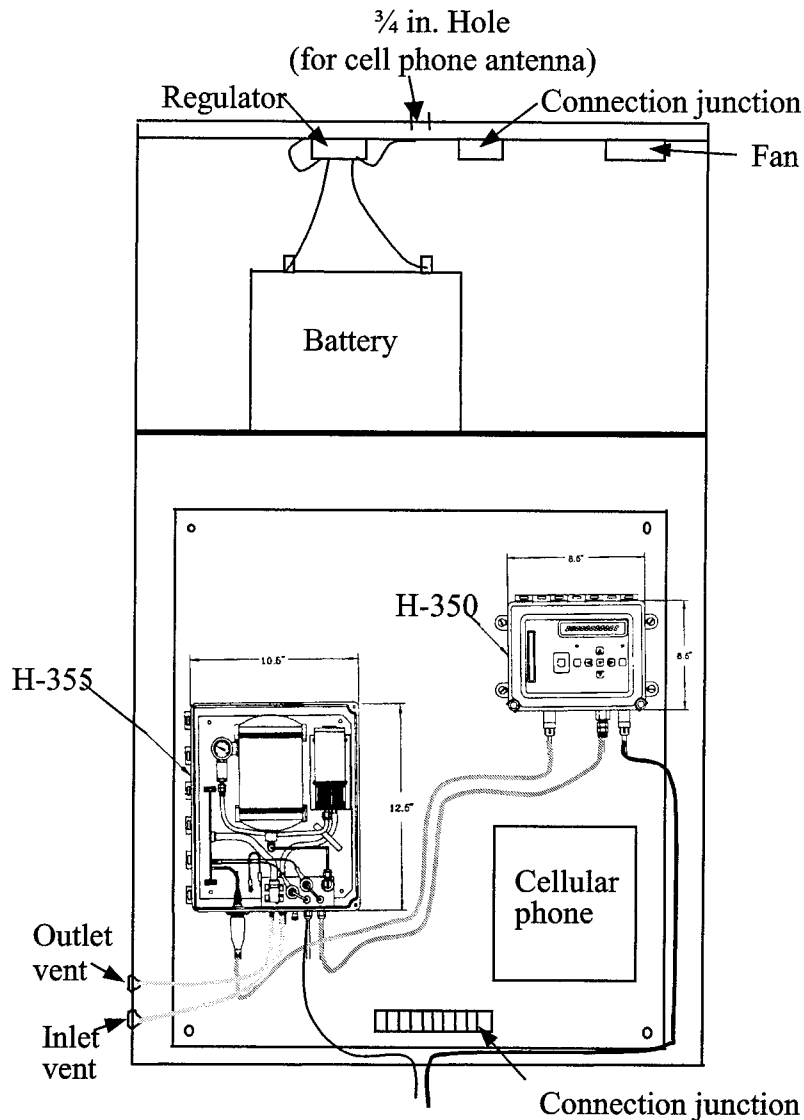

Figure 2.5 Plan view for the main electronics box with units layout

Prefabrication of Depth Monitor Unit (H-240) Protection Box

The distance from pier #6 to the aluminum cabinet is about 200 ft, as shown in Figures 1.1 and 1.2. The prewired cable length for each ultrasonic sensor is only 70 ft. This length is too short to connect the sensors directly to the H-240 if the H-240 is stored inside the aluminum cabinet off the bridge. Therefore, the H-240 depth monitoring unit was installed halfway between pier #4 and pier #5, as shown in Figure 1.2. To protect the H-240 unit, a steel protection box was specified. This box was mounted behind the concrete rail in

order to protect it from traffic. The H-240 unit was connected through a shielded cable 200 ft long to the aluminum box containing the datalogger in order to provide electricity and data transmission capabilities. Figure 2.6 is a picture showing the H-240 unit installed on the side of the concrete rail and the conduit protecting the connections to the ultrasonic sensors and the aluminum box containing the datalogger and other supporting electronics that is located off the bridge.

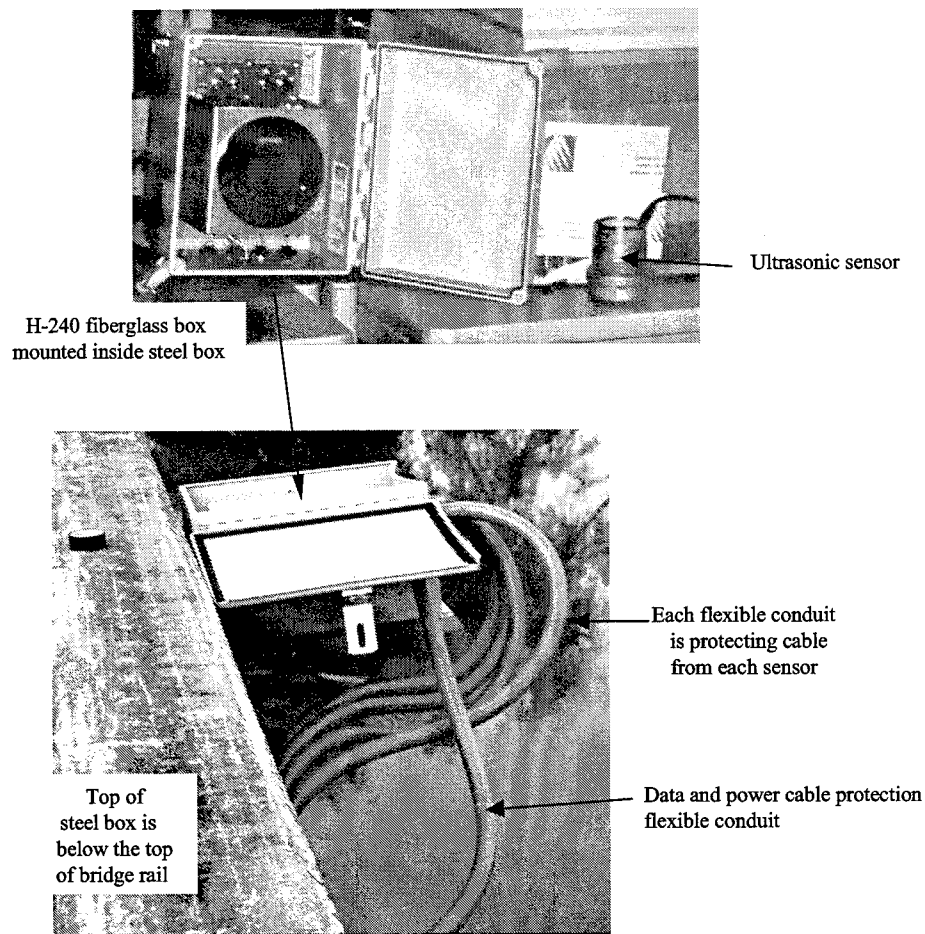

Figure 2.6 Ultrasonic sensor monitoring unit mounted on the concrete rail

Prefabrication of External Assembly

All the parts required for the prefabrication of the sensor external assembly are listed in Table 2.1 and detailed in Figure 2.7. All the parts described in Table 2.1 and Figure 2.7

are made out of schedule 80 PVC and are available from established plumbing supply companies.

Table 2.1 Parts list for transducer external assembly

Part #	Description
1, 2, 6, 7, 11, 12	4 in. dia. SCH 80 PVC T
3, 10	4 in. dia. SCH 80 PVC Pipe
4, 5, 8, 9	4 in. dia. SCH 80 PVC Nipple (Both ends without thread)
13	4 in. dia. SCH 80 PVC Nipple (One end thread)

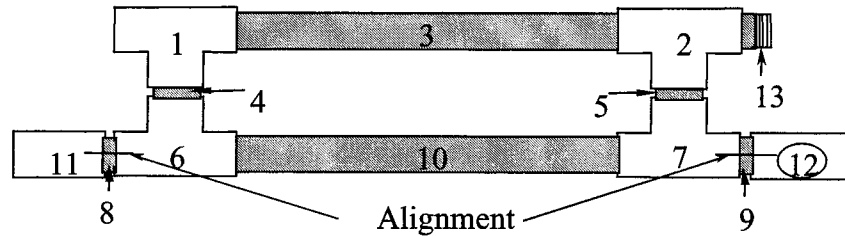

Figure 2.7 Schematics of prefabrication of transducer external assembly

Based on the preliminary measurements performed in the initial field survey and on a study of the bridge plans, decisions were made on the lengths for parts #3 and #10 depicted in Figure 2.7. With the known distance from the bridge deck to the average water level, the distance from the water level to a reachable or serviceable location can be established. The length of part #3 and part #10 in Figure 2.7 is based on this distance. For the specific case of the installation at the Mustang Creek location, the lengths of these parts were set at 5 ft. Additional PVC 4 in. pipe was coupled to part #1, according to field measurements during final installation, so that the ultrasonic sensor head is mounted at a distance of about 1.5 ft from the riverbed. Inserted inside parts #1, #2, and #3 is the assembly holding the ultrasonic sensor head, which will be described later in the report. Parts #11, #8, #6, #10, #7, #9, and #12 are strapped to the bridge pier as described later.

The lengths of part #4 and part #5 depend on the distance from sensor to riverbed and on the angle of the ultrasonic cone of the sensor, providing the required offset for the ultrasonic sensor head. The angle of the ultrasonic cone for the Data Marine ultrasonic sensors used in the installation is 20°. As shown in Figure 2.8, the distance from the sensor to the pier needs to be increased by 2.1 in. for every 1 ft increment of distance from the sensor head to the riverbed.

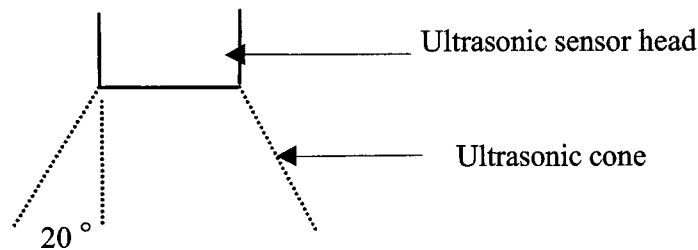

Figure 2.8 Ultrasonic wave cone for the Data Marine ultrasonic sensor used

According to the ultrasonic sensor manufacturer, the distance between the sensor and the riverbed should not be less than 1.5 ft, in order to get a reliable reading. Assuming a distance from the riverbed to the sensor of 3 ft, the minimum distance from the sensor to the bridge pier should be 3 ft times 2.1 in. per foot, which equals 6.3 in. This assumes no interference of footings and other foundation structures. This is the case of the instrumented bridge at Mustang Creek, where the foundation consists of concrete piles.

The inside diameter of part #10 and part #3 is 4 in., and their thickness is ¼ in. The thickness of part #6 and part #1 is also ¼ in. and the length of their perpendicular tips is 2.5 in. Therefore, the distance of sensor to pier is 12.5 in., independent of the length of part #4 and part #5. In this specific installation, part #4 and part #5 can be cut to a minimum length, which should be 4.5 in. to provide for a proper connection of the PVC parts.

The procedure for assembly and gluing of the parts is as follows:

1. Cut two pieces of 4 in. SCH 80 PVC pipe (part #3 and part #10). Part #3 must be ¼ to ½ in. shorter than part #10. Cut another four pieces of the same pipe 4.5 in. long (part #4, part #5, part #8 and part #9).
2. Find a flat ground for assembly.
3. Prejoin part #1 and part #2 to each end of part #3.

4. Apply cement and join part #4, part #8 and part #5, part #9 to part #6 and part #7 respectively.
5. Prejoin (without applying the PVC cement) part #6 and part #7 to the end of part #10, and then prejoin part #11 and part #12 (both are 4 in. SCH 80 T) to part #8 and part #9, respectively. Now take the prejoined assembly consisting of part #1, part #3, and part #2, and prejoin it to part #4 and part #5, respectively. One person steps on the top of part #11 (4 in. T) and another person steps on the part #12 (4 in. T). Align the whole assembly so that part #4 and part #5 are vertical, and make sure that the perpendicular tips of part #11 and part #12 (T) are touching the ground. Mark the alignment as shown in Figure 2.7.
6. Disassemble the prejoined assembly.
7. Apply cement to both part #11 and part #8, then push part #8 into part #11 slowly in order to align the alignment mark.
8. Repeat step 7 for joining part #9 to part #12.
9. Apply cement and join part #10 to part #6 first, then join the other end to part #7. While joining to part #7, some precautions need to be taken. Immediately after cementing and joining part #10 to part #7, one person has to stand on part #12 and another on part #11. This is to make sure that the perpendicular tips of both parts are touching the ground, and part #4 and part #5 are vertical.
10. Apply cement on part #3 and part #1, and join them together.
11. Apply cement on part #3 and part #2. Immediately join part #2 to part #3, and simultaneously prejoin part #2 to part #5 and part #1 to part #4.
12. Separate part #1 and part #2 from part #4 and part #5, respectively.
13. Two people are needed to apply the cement on part #1 and part #4 and on part #2 and part #5. The pieces are then joined simultaneously. The timing is critical; the two people must have the same speed in applying the cement and joining the parts.
14. Apply cement and join part #13 to part #2. Do not spill any cement on the threaded portion of part #13.

Prefabrication of the Internal Assembly

All the parts required to prefabricate the internal assembly are shown in Table 2.2 and Figure 2.8.

Table 2.2 Parts list for prefabrication of internal assembly

Part #	Description
1	1 in. zinc anvil hose comb nipple
2	2 in. x 1 in. SCH 80 bushing (threaded)
3 & 8	2 in. dia. SCH 80 coupling
4	2 in. dia. SCH 80 PVC pipe
5 & 6	4 in. x 2 in. SCH 80 bushing (non-threaded, interior needs to be machined to allow 4 in. pipe to go through)
7	4 in. dia. SCH female adapter (one side threaded, the other non-threaded)

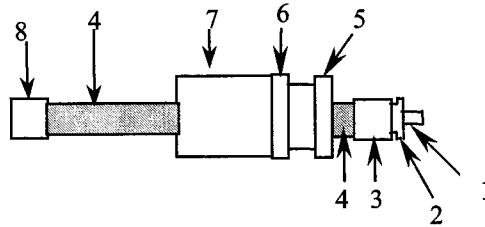

Figure 2.9 Schematics of prefabrication of transducer internal assembly

Before one starts fabrication, parts #5 and #6 need to be machined to allow the 2 in. diameter pipe to go through. The fabrication involves the following steps:

1. Cut a piece of 2.5 ft long, 2 in. diameter SCH 80 PVC pipe (part #4).
2. Mark the cement application area (begin at 8 in. from one end and apply 2 further in. of cement) on part #4. Apply cement on this area and push part #6 until it reaches the mark. Repeat this procedure for part #5, but make sure it is sitting on part #6.
3. Apply cement on both part #7 and part #6, and join them together. Do not let cement drip onto the inner thread of the female adapter (part #7).
4. Permanently connect part #8 to part #4, then part #3 to part #4 (the other end of the pipe).

5. Apply cement on part #2 and part #3 and join part #2 to part #3.
6. Apply Teflon tape on the threaded portion of part #1, and screw part #1 into part #2.

FIELD ASSEMBLY AND INSTALLATION

Preliminary Arrangements before Going to the Field

For this particular installation at the Mustang Creek location, and because of the characteristics of this bridge, arrangements were made with TxDOT to provide a snooper crew with equipment at the site to support the installation. Efforts were made to minimize the involvement of the snooper crew in the installation, due to the costs and high demand for the crew at other locations throughout the state to support the bridge inspection program. Another reason to minimize the involvement of the snooper equipment in the installation was the effect it had on traffic in the work zone. The snooper equipment used was wide, and it encroached on the other lane of this narrow two-lane bridge with no shoulder. For these reasons, the snooper crew involvement was scheduled for one day. However, the whole installation lasted for two extended-hours work days, from 9 a.m. to 7:30 p.m. Figure 2.10 depicts the snooper crew and equipment during the installation. It also shows the sensor assemblies already strapped to the bridge piers and the conduit and junction boxes in place.

In order to guarantee safety and to work efficiently, the researchers made arrangements with TxDOT to provide a traffic control team at the construction site. As discussed before, the site was a two-way, two-lane bridge with narrow lanes and no shoulders. Traffic control had to be provided by flaggers. The traffic control crew had to work extended hours to support the installation over two days.

To support the installation of the main box of the bridge and to install all the conduit and run the cables for the installation, a TxDOT signal shop crew was requested from TxDOT's Yoakum District office. The signal shop crew was involved in the installation for two extended-hour days while working with the UTSA crew.

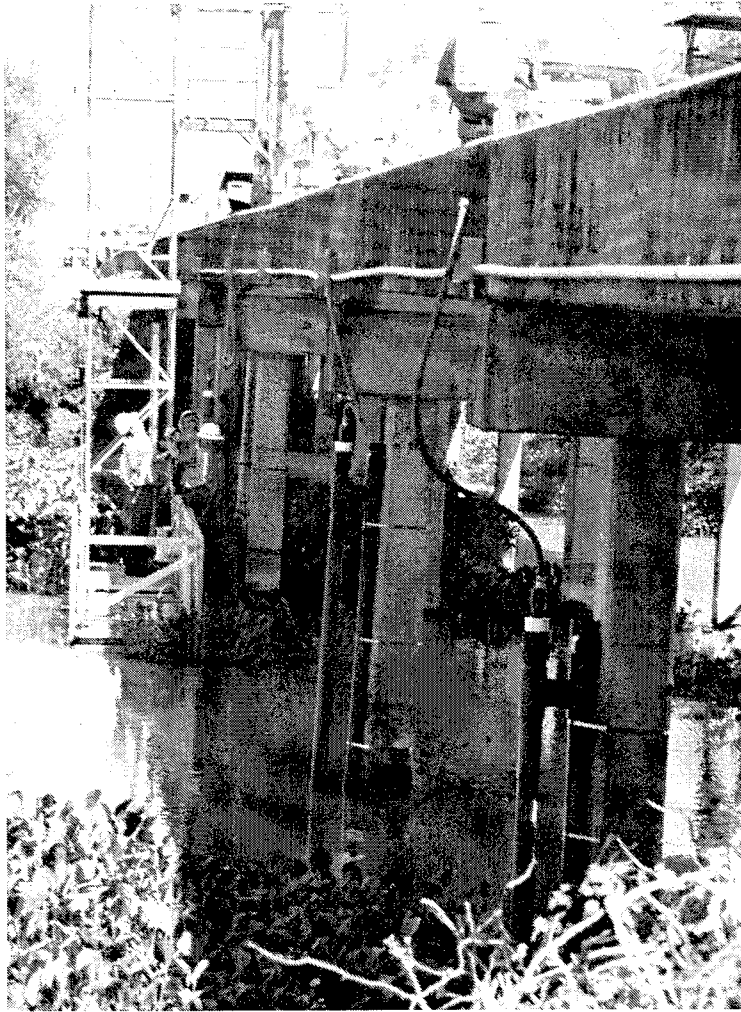

Figure 2.10 Snooper crew during installation

Field Assembly of the External Assembly

It is difficult to prefabricate the entire assembly in the laboratory. For example, the complete assembly may be too heavy and too long to manipulate and transport to the site. In addition, the distance between the ultrasonic sensor and the riverbed is usually decided in the field, right before installation. For these reasons, both the transducer external assembly and internal assembly were finalized at the site. The lengths of the required extensions were a function of the depth of the water on the day of installation.

After arriving at the site, the researchers measured the water depth at each pier where an ultrasonic sensor was going to be attached. With the help of the snooper crew, these measurements were made quickly and accurately. The snooper lowered its basket close to the

water surface, and a person inside the basket lowered a survey rod down to the riverbed and measured the water depth.

Figure 2.11 depicts the schematics for the finalized external assembly, while Table 2.3 includes the parts list. After the depth of water at each pier location was measured, the length of part #14 was determined. As discussed before, the target location for the sensors was 3 ft above the riverbed. The ultrasonic sensor has to protrude out about 0.5 ft from part #17, which needs to be machined to allow the sensor head to go through it. The length of the extension equals the water depth minus 3.5 ft, when the bottoms of part #1 and part #6 shown in Figure 2.9 are touching the water. Final coordinates for the sensor head need to be recorded after the assembly is strapped to the pier.

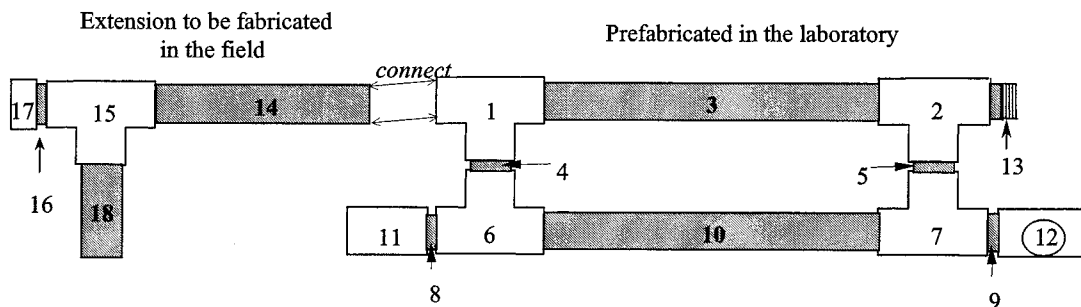

Figure 2.11 Finalized external assembly

Table 2.3 Part list for the extension of external assembly

Part #	Description
14	4 in. dia. SCH 80 PVC pipe
15	4 in. dia. SCH 80 PVC T
16	4 in. dia. SCH 80 PVC nipple/pipe
17	4 in. dia. SCH 40 PVC cape
18	4 in. dia. SCH 80 PVC pipe

The sequence of assembly for the finalized external assembly is as follows:

1. Apply cement and connect part #16 to parts #17 and #15. Part #17 is a premachined SCH 40 PVC cape for the ultrasonic sensor to pass through.
2. Lay the connected parts on the ground, and preconnect them to a piece of SCH 80 PVC pipe (assuming this is part #14). Using a measuring tape, measure and mark the length established earlier from the end of part #17 to a point in the PVC pipe.
3. Disassemble and cut; the resulting piece of PVC pipe is part #14.
4. Apply cement and connect part #14 to part #15.
5. Without applying cement, connect the other end of part #14 to part #1 as shown in Figure 2.11. Holding the parts vertically, measure the length from the ground to the connection limit of part #15. The connection limit is about 2.2 in. from the edge of part #15.
6. Cut a piece of SCH 80 PVC pipe (part #18) according to the measured length in step 5.
7. Two people are required for this step. Disconnect part #14 from part #1; one person applies cement on part #14 and part #1, while the other person applies cement on part #18 and part #15. Connect part #14 to part #1 and part #15 to part #18 simultaneously. Meanwhile, make sure part #18 is vertically aligned.

The fabrication of the external assembly is completed and is ready to be combined with the internal assembly. However, the internal assembly also needs to be extended before it can be inserted into the external assembly.

Internal Assembly Extension

All the required parts for fabricating the internal assembly extension are listed in Table 2.4, and their connections are shown in the schematics depicted in Figure 2.12.

Table 2.4 Part list for internal assembly

Part #	Description
10	2 in. SCH 40 PVC pipe
11	2 in. SCH 80 female adapter
12	Ultrasonic sensor

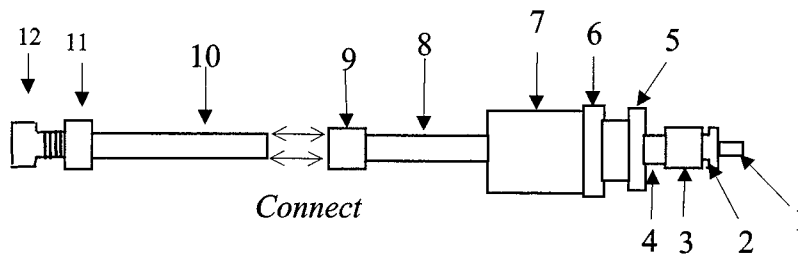

Figure 2.12 Finalized internal assembly

The following steps are followed in fabricating the extension:

1. Apply the Teflon tape to the threaded part of the ultrasonic sensor and screw it into part #11. Use a pipe wrench to hold part #11 and tighten part #12. Be sure not to damage the sensor and its cable.
2. Measure the length of the external assembly shown in Figure 2.11 from the end of part #17 to the end of part #13. We will call this length “L” for further reference.
3. Lay the prefabricated internal assembly shown in Figure 2.9 on the ground. Without applying cement, connect a 2 in. SCH 40 PVC pipe (part #10) to part #8. Measure “L” from the furthest inner thread of part #7 to part #10. Mark it and disconnect it from part #8.
4. Cut the marked length of part #10. Pass the sensor cable through part #10 and apply cement on part #10 (at one end). Connect part #10 to part #11. Be careful not to cement the sensor cable.
5. Pass the sensor cable through from part #8 to part #1. Apply cement to the other end of part #10 and connect it to part #8.

6. Bring this completed internal assembly and insert it into the transducer external assembly depicted in Figure 2.11. Screw part #7 in Figure 2.12 into part #13 in Figure 2.11.

Fabrication of the internal assembly for the bubbler is similar to that for the ultrasonic sensor. The only difference is that, instead of an ultrasonic sensor, a bubbler orifice is used for part #12 in Figure 2.10. Fabrication of the bubbler external assembly and attachment is simpler. The orifice in the bubbler does not require any offset from the pier as does the ultrasonic transducer. The external assembly for the bubbler orifice is depicted in Figure 2.13 and shares the same parts list as the external assembly. The finalized assembly is depicted in Figure 2.14.

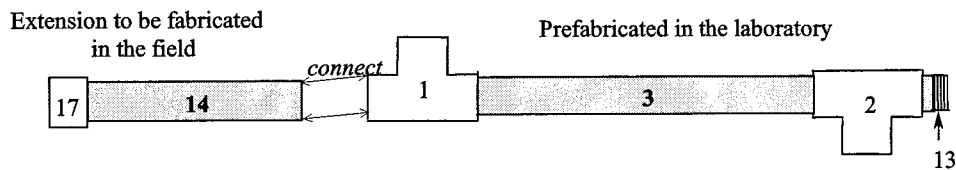

Figure 2.13 External assembly for the bubbler orifice

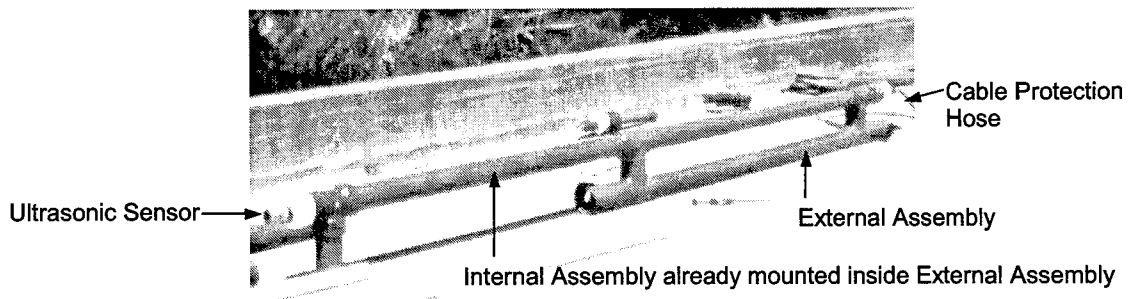

Figure 2.14 Sensor assembly ready for strapping to piers

Attachment to the Piers

For this particular bridge, a rope was tied to the finished assembly and the entire assembly was lowered from the bridge deck to the pier. Two to three people were needed in the snooper basket to align the assembly vertically and align the sensor assembly with the water level mark so that the sensor head was at the planned distance from the riverbed.

Stainless steel Band-It strapping was used in two layers to strap the finalized assembly onto the pier as shown in Figure 2.15.

The layout of the completed installation of all four ultrasonic sensors is shown in Figure 2.16. The ultrasonic sensor mounting assembly is attached to piers #3, #4, #5, and #6. The final coordinates for the sensor heads, at the day of the installation, are depicted in Figure 2.16.

The installation procedure for the bubbler mounting assembly is similar to the installation procedure for the ultrasonic sensor mounting assembly. However, the bubbler mounting assembly is installed on the opposite side of pier #4, so it cannot be seen in Figure 2.16.

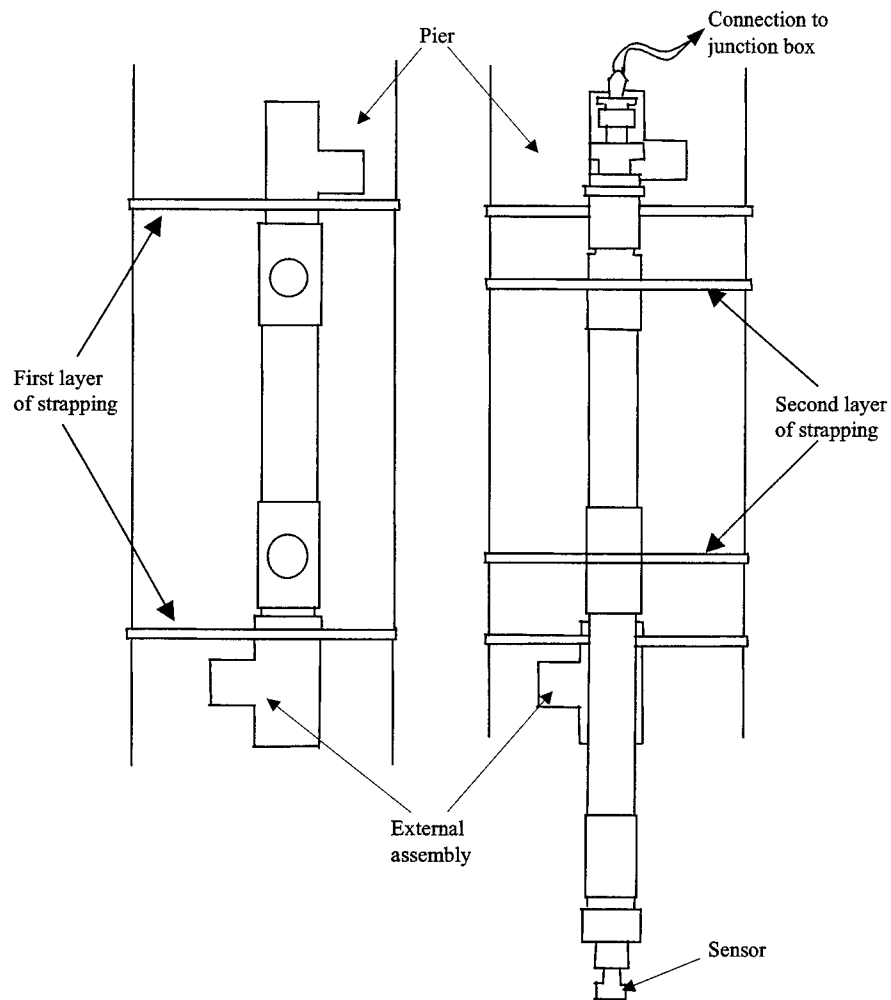

Figure 2.15 Attaching the ultrasonic mounting assembly to the pier

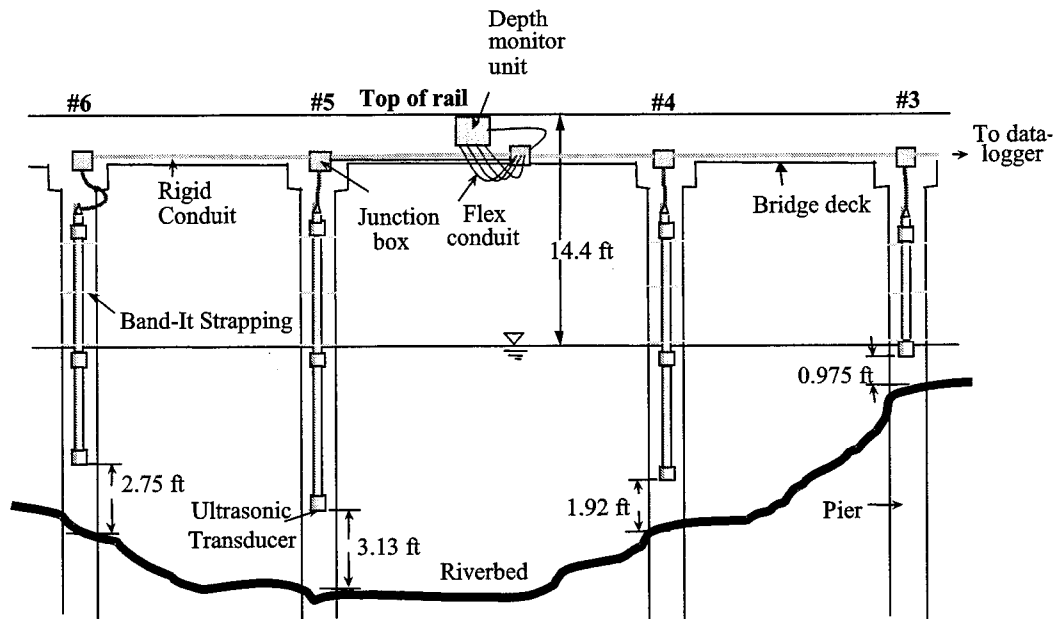

Figure 2.14 Layout of the completed installation

Installation of Junction Boxes and Conduits

The approximate locations of the installed junction boxes and conduits are shown in Figure 2.16. Rubber hoses, ultraviolet ray resistant, were used to connect the 1 in. zinc anvil hose combination nipple (part #1 in Table 2.2) to the junction boxes. The hoses protect the sensor cable that runs from the PVC assembly to the junction box.

Installation of the H-240 (Depth Monitor Unit) Protection Box

The H-240 steel protection box was installed on the outside of the bridge's concrete rail in a place that would allow servicing while keeping it protected from traffic. Its position is shown in Figure 2.16. The box was installed on a steel bracket bolted to the concrete rail. Unfortunately, this position proved to be inadequate. Even though the box was mounted about 1 ft from the top of the rail on the outside, a piece of farm equipment managed to hit and severely damage the box. The design was modified (this modification is discussed in a subsequent chapter in which the Phase II installation is documented).

Mounting of Aluminum Cabinet and Solar Panel

Both the aluminum cabinet and solar panels were mounted on a treated wooden pole installed at the site specifically for this purpose; see Figure 1.1 for its location. The selection of solar panels and battery are described in Appendix A.

The orientation of the solar panels is such that it captures the maximum solar power possible. To optimize performance during the winter in Texas, the solar panels have to be tilted south. The tilting angle relative to the horizontal has to be equal to the latitude of the site plus 15 degrees. At this bridge site, the latitude is about 29 degrees. Therefore, the solar panels were installed at an angle of 44 degrees relative to the horizontal.

A cable coming out of the aluminum cabinet was protected by a flexible conduit and connected to a junction box. The two solar panels were connected in parallel in a connection inside the junction box depicted in Figure 2.17.



Figure 2.15 Aluminum cabinet and solar panel mounted on wooden pole

Connections of Cables and Bubbler Tubing in the Field

The wiring schematic of the system is shown in Figure 2.18. To connect the ultrasonic sensor cables to the depth monitor unit (H-240) inside the steel box attached to the concrete rail, first pass the cable through a heavy-duty hose and connect this hose to part #1 in Figure 2.9, using a steel clamp to clamp the hose tight.

Continue passing the cable through the junction box attached to the side of the concrete rail. Fish each ultrasonic sensor cable through the rigid conduit from the appropriate junction box. Next, pass each cable through a flexible conduit and connect it to the H-240 unit inside the steel box.

One end of the data power cable needs to be connected to the H-240 unit; the other end needs to be connected to the datalogger inside the aluminum box, which is about 150 ft away, outside the bridge. The selected cable in this project had three small wires in different colors. The white wire was selected for SDI-12 data transmission, the red wire for the positive terminal, and the black wire for the negative terminal or ground. After one end was connected to the H-240 unit, the cable was fished through a very long path inside the conduit attached to the side of the concrete rail, all the way to the aluminum cabinet. Finally, the cable was attached to the proper connectors inside the aluminum box.

The bubbler tubing was routed to the junction box above pier #4 and fished all the way to the aluminum box, where it was connected directly to the H-355 unit. This connection is critical, and a small leak may cause faulty pressure readings.

As shown in Figure 2.18, the cable from the solar panels must be connected to the regulator before it can be connected to the battery.

In this particular system, two solar panels were used. Two cables were used to connect the solar panels in parallel in order to add the amperage. The connection is in a junction box attached to the wooden pole.

Another cable connects the junction box to the terminals of the regulator inside the aluminum box. After this, a short cable is connected from the output terminals of the regulator to the positive and negative terminals of the battery. All the cables used must be at least AWG 18. A flexible conduit was used to protect the cable connecting the aluminum cabinet to the junction box.

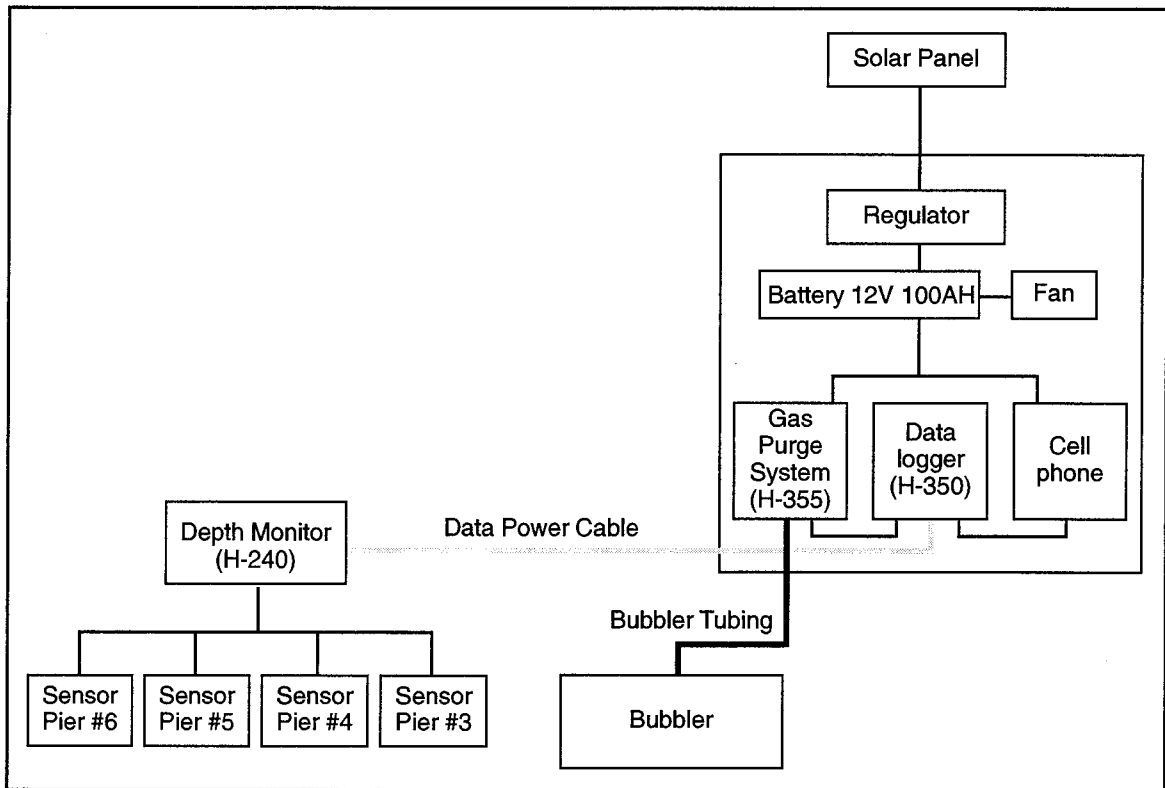

Figure 2.18 Wiring schematics for the installation

Pressure Line Connection between H-350 and H-355

This section explains how to connect a pressure line between the H-350 and H-355 units. Figure 2.19 illustrates the physical features of the H-350 connector panel and briefly discusses each connector. Figure 2.20 illustrates the physical features of the H-355 connector panel. These two figures help determine where the connections should be made.

To make the pressure line connections for the bubbler line, follow these steps:

- Apply a coat of Teflon tape on the NPT threads of the male 1/8 in. NPT fitting and screw it into the pressure input port of H-350 connector panel shown in Figure 2.19.
- Apply Teflon tape to a 1/4 in. NPT female to 1/8 in. tubing fitting and screw it into the H-350 sensor port shown in Figure 2.20.
- Connect the pressure line (1/8 in. copper tubing) between the H-350 and H-355. The procedure for installing the pressure port fitting is illustrated in Figure 2.21.

The proper ferrules must be used to ensure that there are no leaks. Note: the H-355 must be installed vertically.

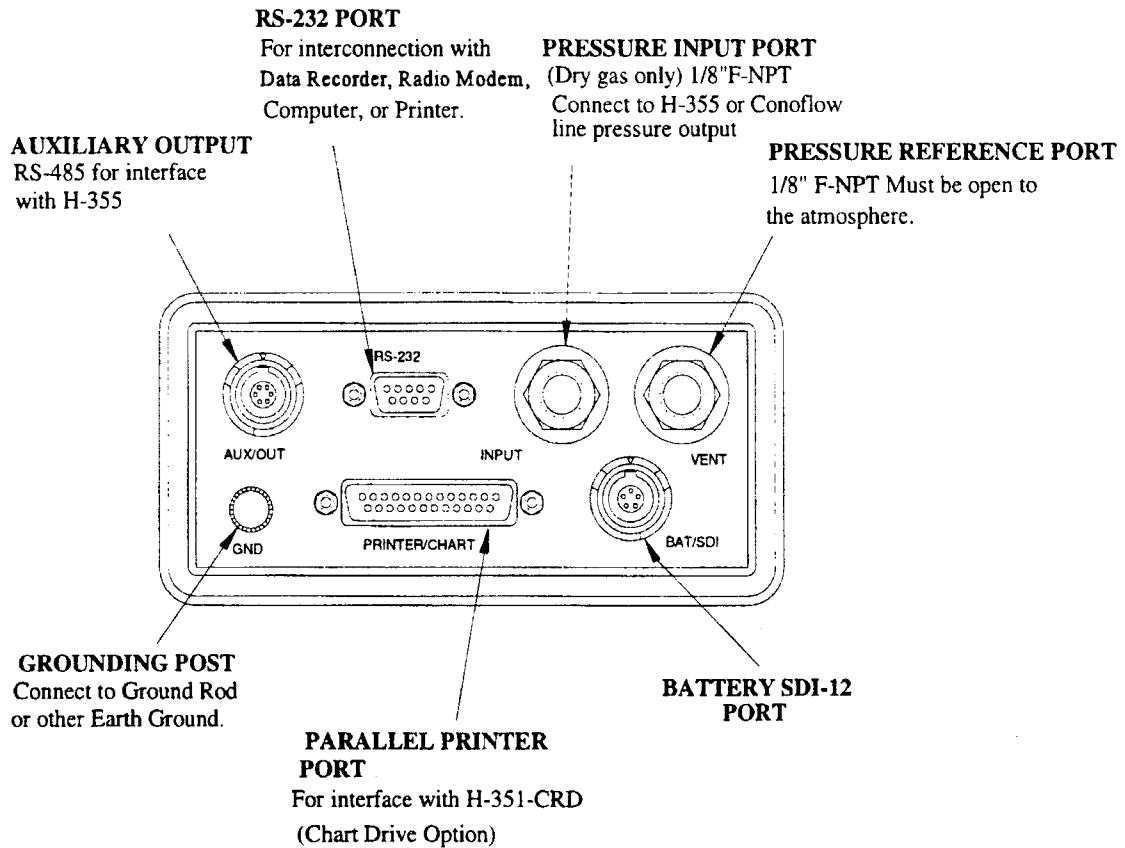

Figure 2.19 H-350 Connector panel

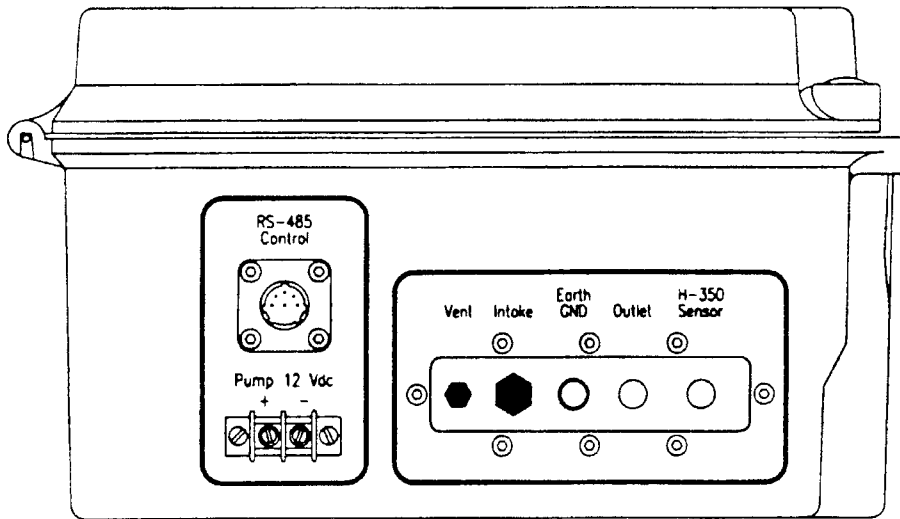

Figure 2.20 H-355 Connector panel

WARNING: YOU MUST ALWAYS USE A BACKUP WRENCH.

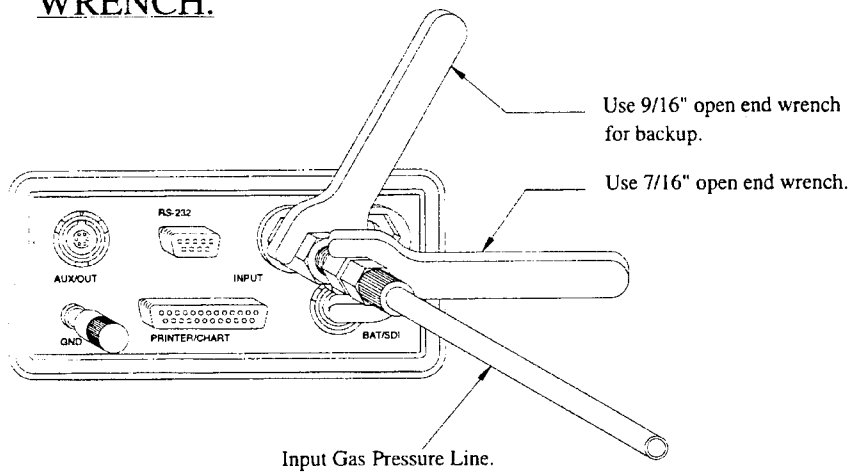

Figure 2.21 Pressure port fitting installation

Wiring Connection and Software Setup

Wiring and connections are required for the system to work properly. The following will describe the electrical connections for each component.

The connection junction shown in Figure 2.22 is installed at the bottom of the back plate shown in Figure 2.5. It has three bridges: positive, negative, and data. The connection junction is used to connect the power from the battery to the H-350, H-355, and H-240 in parallel.

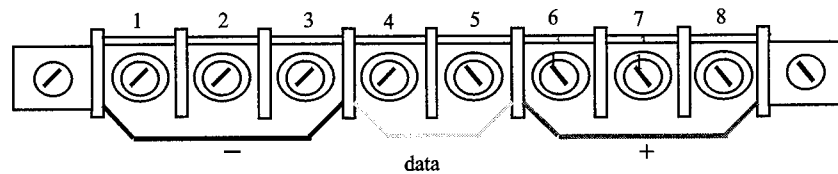

Figure 2.22 Connection junction inside aluminum box

The connection procedures are:

- Connect the positive terminal (+) and the negative terminal (-) of the battery to numbers 8 and 1 of the connection junction depicted in Figure 2.22 using AWG 14 cables.
- Connect the shielded cable terminals coming from the H-240 unit in the small box attached to the bridge rail to the proper positive and negative blocks. Connect the data (SDI-12) cable to the data block depicted in Figure 2.22.
- Make sure the proper ground connections are provided for the cable coming from the H-240 unit in the small box attached to the bridge rail.
- Connect the RS-485 cable from the auxiliary output port to the RS-485 control port. The RS-485 port is used for interfacing between the H-350 and H-355 units.

After all the cable connections described are made and the battery is hooked up, the power light of the H-350 datalogger should begin to flash every 5 to 10 seconds. This indicates that the battery is providing a 10-V or greater voltage to the system. If the display

button is pressed in the H-350, the one-line vacuum fluorescent display should come on, enabling the datalogger to be set up.

The cell phone is installed at the lower right corner of the back plate, as depicted in Figure 2.5.

The nine-pin serial connector (RS-232 port) shown in Figure 2.19 can be used to communicate directly to a laptop computer for field data retrieval or setup. This port also allows connection to a modem connected to a cellular phone or a land line for remote data retrieval and limited setup procedures. When connecting the H-350 directly to a laptop computer, one must use a NULL modem cable.

Datalogger Setup

Before researchers measure water levels and logging date from the ultrasonic sensors, the datalogger needs to be set up.

The following explanations refer to Figure 2.23.

- On/off button: Allows you to turn the display on and off. The display will automatically turn off after 5 minutes if no keyboard activity is sensed.
- PCMCIA memory card slot: Accepts an industry standard 1 megabyte PCMCIA “Flash” memory card. The H-350 datalogger stores the desired data on this flash card. This stored data can be transferred to a computer with a PCMCIA card reader that supports the Flash File System 2 format. Data can also be accessed via a simplified menu through a computer connected with a serial connection to the RS-232 port.
- The enter button has five functions: (1) To activate the submenus of menus with “< >” field. For information about menus, please refer to Appendix B. (2) To open “[]” fields that can be modified. (3) To accept the edited values. (4) To answer ‘Yes;’ e.g., if the display message shows “Format Flash Card?” press the enter key for Yes and cancel key for No. (5) To start making pressure and water head measurements when pushing the enter key while in the “stage” or “pressure” fields.

- Cancel button: To abandon the edits (similar to the Escape key on a computer). To return to the previous menus.
- " and ... keys: To scroll from one menu to another. To edit numerical or character parameters. To make choices.
- ⊗ and ≡ keys: To move the cursor back and forth across the screen.
- <.> Key: To change the position of a decimal point.
- Error LED: To indicate the battery power is sufficient. If the battery power falls below 10V, the monitor LED stops flashing.
- Display: Allows user to view choices.

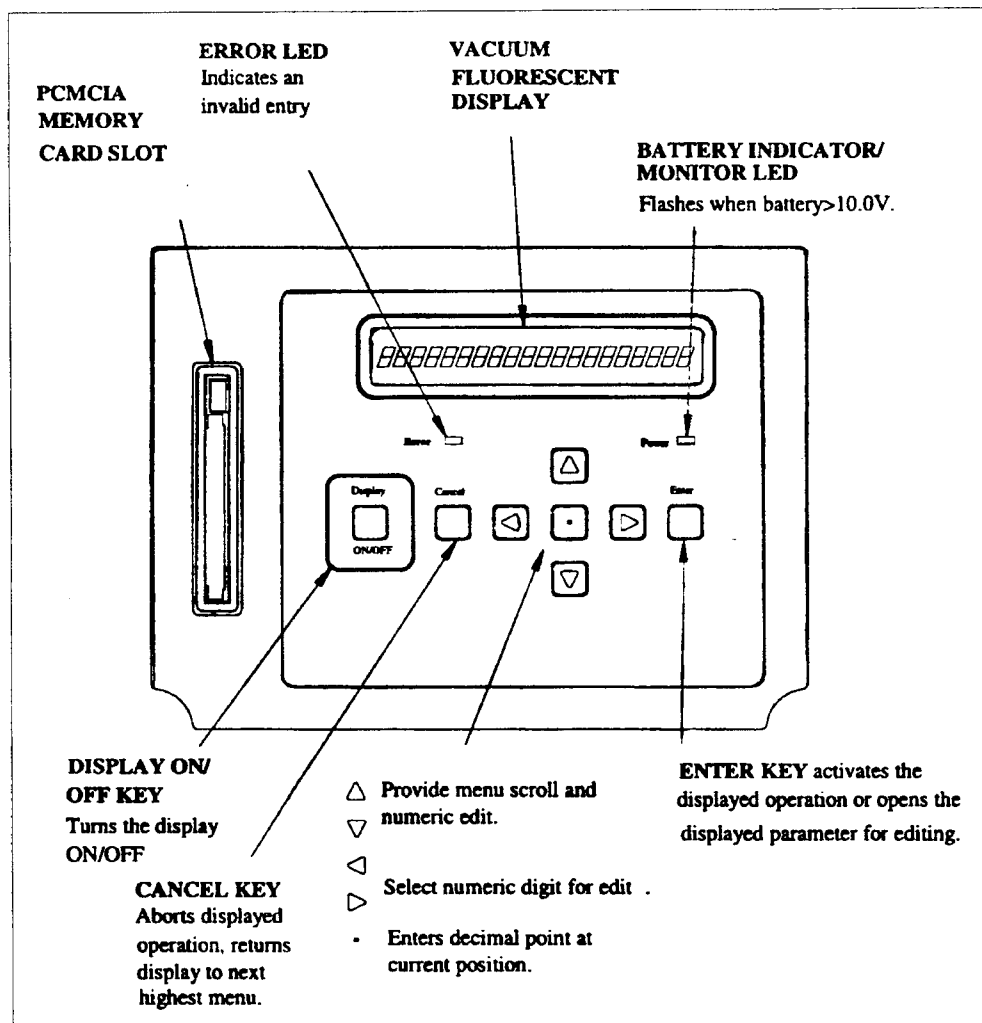

Figure 2.23 Datalogger controls and display

Using the flowchart presented in Appendix B, the user is able to make changes for the H-350 setting parameters. For example, to set “Stage” equal to the distance in feet from a datum to water level, the following procedure can be used:

- Let’s take datum to be the top of the bridge rail.
- Turn on the display and refer to Appendix B.
- Press ... five times; when you see < Edit Coefficients >, press enter.
- Now you can see < Edit Stage Scalar >; press enter again.
- Now you can see Offset: [xx.xxxxxx]. Use \equiv or \otimes to move the cursor around the screen and use ... or " to change the numerical values and characters. Use the <.> key to place the decimal point. Assume that the distance between the datum and the orifice is 14.77 ft. Enter -14.77 for Offset and press enter. Please note that 14.77 ft is the distance from the top of the rail to the bubbler orifice as installed at the Mustang Creek site.
- Press ... one time; you will see Slope: [xx.xxxxxx]. Enter 2.3067 and press enter to accept it. This assumes water density to be 62.4 lb/ft³.
- Press cancel several times to return to the stage: xx.xxx.
- If you press enter, the stage will be the distance between the water level and the datum in feet.

Similarly, the user can navigate the menus for the datalogger presented in Appendix B and access the <logging parameters> sub menu. In this menu, after activating the <Flash Reports Options>, the user can format the data file to be stored in the flash card. For this installation, the parameters selected for inclusion in the report are summarized in Figure 2.24, which depicts the Excel spreadsheet containing a sample of the data retrieved at the Mustang Creek site during the Phase I installation. Dates refer to the year 1998, as the system was installed on August 20, 1998. The first row includes the headers generated by the datalogger, and the second row shows headers added to the spreadsheet to aid the reader’s understanding of the values. SDI-01 is the sensor attached to bent #6, and so on. “Temperature” refers to the temperature inside the datalogger, and “Stage” refers to the distance from the top of the concrete rail to the surface of the water. Figure 2.24 should be examined in conjunction with Figure 2.16.

DATE	TIME	PRESSURE	SDI-01	SDI-02	SDI-03	SDI-04	BATT	TEMP	STAGE
DATE	TIME	PRESSURE	BENT-6	BENT-5	BENT-4	BENT-3	BATT (V)	TEMP (oC)	STAGE
23-Aug	22:55	0.577	2.8	0	2.4	0	11.7	29.2	-13.441
23-Aug	23:55	0.523	2.6	0	2.3	0	11.7	28.9	-13.566
24-Aug	0:55	0.5459	0	3	2.3	0	11.7	28.7	-13.513
24-Aug	1:55	0.5685	2.7	4.4	2.3	0	11.7	28.4	-13.461
24-Aug	2:55	0.5504	2.9	3.8	2.3	0	11.7	28.2	-13.503

Figure 2.24 Excel spreadsheet containing a sample of the data retrieved at Mustang Creek

Modem Setup

Before the data interface can be used, the modem must be programmed to make the data interface active. To set up the modem, perform the following steps (refer to Figure 2.25 for connections between the transceiver/modem and the computer):

- Connect the 9-pin DIN end of the RS-232 cable into the RS-232/serial port jack on the transceiver/modem combination.
- Connect the other end of the cable to the serial port on your computer.
- Configure the serial port: Turn on the modem/transceiver first, followed by the personal computer. Set the computer communications software (terminal emulation program) to 9,600 bps or lower.
- Set the type of flow control to hardware flow control by typing `AT&K3\G1 <CR>`
- Set `ATS36=7` and `ATS48=7` to support both cellular and non-cellular originating modems. The original factory configuration is `AT*H1)M1` set to connect to other MNP 10 cellular modems.
- Type `ATS0=1<CR>` for auto-answer. Actually register S0 can be set to a value from 1 to 255. It determines the number of rings before automatically answering a call.
- Type `AT&Wn<CR>` for saving the setting.

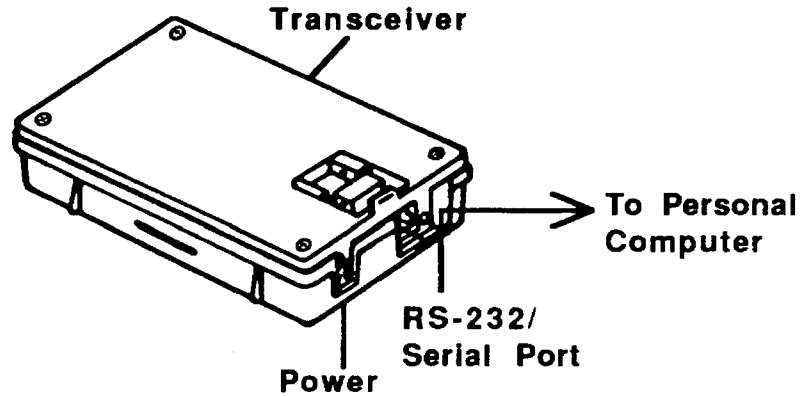

Figure 2.25 Connection between transceiver/modem combination and computer

After setting up the modem, reconnect the transceiver/modem combination to the datalogger (H-350) serial port to allow remote data retrieval.

REMOTE CONTROL AND DATA DOWNLOAD

Some system configurations can be altered, and data stored in the PCMCIA flash memory card can be downloaded remotely. To perform these operations, the user needs to have a computer hooked up to a phone line through a data modem. This computer must have a terminal emulation program, such as the HyperTerm, provided with Windows 95, 98, or NT. Note that the H-350 datalogger is connected to the transceiver/modem combination via an RS-232 cable.

By dialing the transceiver/modem combination stored in the aluminum cabinet at the field, the remote computer will be connected to the H-350 (datalogger). Figure 2.26 shows the simplified menu that can be accessed through this remote connection. Option “d” allows for data retrieval and display on the screen of a terminal emulator such as HyperTerm. Once the data are displayed on the screen, they can be copied and pasted in an Excel spreadsheet using the standard Windows procedures.

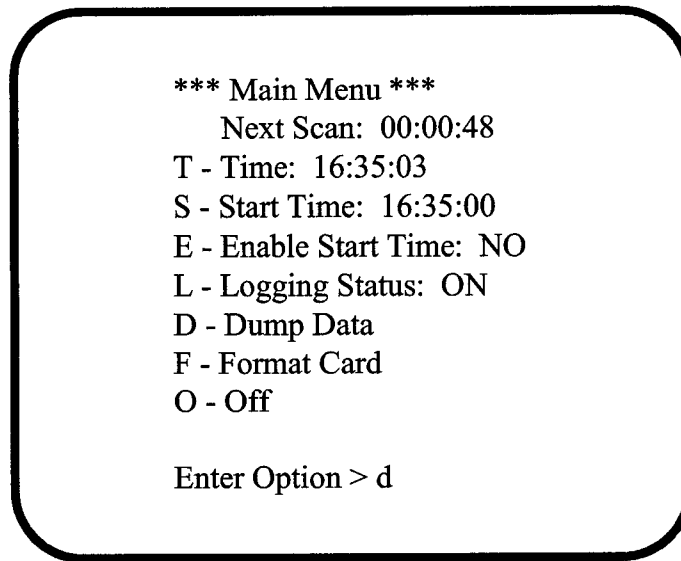

Figure 2.26 Menu for data retrieval and limited setup for the H-350 datalogger

DISCUSSION OF THE PERFORMANCE OF THE PHASE I INSTALLATION

The Phase I installation equipment performed acceptably throughout the life of the installation. Unfortunately, the small steel box containing the ultrasonic depth monitoring unit was hit twice by farm equipment using the bridge. These accidents happened despite the fact that the box was shielded behind the concrete rail. The first impact slightly damaged the outside steel box and cut the ultrasonic sensor cable for the sensor attached to pier #3. The UTSA team visited the site and repaired the damage. The second time the box was hit by farm equipment, around March 15, 1999, the lids for both the steel box and the fiberglass box were torn out, exposing the electronics to rain and moisture and virtually destroying the ultrasonic depth monitoring unit attached to the bridge rail. The Phase I installation lasted from August 20, 1998, until the estimated date of the damage. The UTSA staff later replaced the depth unit and upgraded the datalogger and communications for the site. This upgrade is described in Chapter 3 of this report and is referred to as the Phase II installation by this report.

The following limitations of the Phase I setup deserve to be summarized:

The bubbler orifice seems to get easily clogged by algae, and even the automatically triggered unclogging routines built into the system do not seem to take care of the problem. This led to unreliable measurements for stage.

The transceiver/modem combination performed poorly. Most of the time, connections to the cellular phone were unreliable and difficult to attain. One of the reasons for the poor performance of the cellular communications at the site could have been the fact that the phone number assigned during activation was a San Antonio area code number. This forced the unit to operate in roaming mode which could be an explanation for the communication instability.

Generally, the system performed as expected and was able to monitor the site during the flood of 1998, helping the Yoakum District maintenance engineer during an emergency period when resources were scarce to deal with the vast amount of roadway maintenance emergencies.

For a cost estimate and list of materials used in the Phase I installation, please refer to Appendix C. It is estimated that the installation of the Phase I pilot site cost between \$15,000 and \$18,000, not including the research time and procuring time involved in developing the drawings and specifications.

CHAPTER 3. DESCRIPTION OF THE HARDWARE AND SOFTWARE USED IN PHASE II OF THE PILOT SCOUR MONITORING SITE

INTRODUCTION

The Phase II installation provided the opportunity to test the many improvements made to the hardware and software used in the Phase I installation at the FM 1157 Mustang Creek site. The H-350 datalogger was replaced by a Campbell Scientific¹ CR10X datalogger. The new datalogger, besides being fully programmable, has several additional features, such as the ability to monitor several different input channels, combine different sensor types such as ultrasonic sensors and sliding-collar sensors, and generate alarm calls for preprogrammed threshold values for the readings. This datalogger also has the ability to control such external processes as switching flashing beacons on and off. The Mitsubishi transceiver/modem combination was replaced by a Campbell Scientific field modem combined with a Motorola cellular phone package, which performed far better than the previous communication package. The H-355 bubbler unit was replaced by a pressure transducer, also purchased from Campbell Scientific. The assembly for the steel box containing the H-240 ultrasonic interface depth monitoring unit was mounted at the same location, though it was redesigned to mount the steel box further below the top of the bridge rail in order to protect it from impacts from traffic. All the solar sensor assemblies were kept in place at the same pier locations.

The CR10X datalogger activates one sensor at a time to perform measurements at certain intervals programmed in the datalogger software language. The data stream is tested for specified thresholds for scour and water level. If any threshold is violated, the CR10X datalogger will power-up the cellular phone and initiate an alarm callback. During the callback, the CR10X datalogger will send to a remote computer at the maintenance office a three-digit callback ID that identifies the sensor that generated the emergency reading. When the computer at the maintenance office receives the callback, software in the office computer will initiate a command associated with the callback ID, activating a specific pager software package and sending a prestored alphanumeric pager message to a bridge maintenance

¹ Campbell Scientific, 815 W. 1800 N., Logan, Utah, 84321, phone (435) 753-2342, FAX (435) 750-9540

engineer communicating the emergency. In addition, readings of all sensors attached to the datalogger, occurring at preprogrammed intervals, are stored in the datalogger’s memory and can be retrieved remotely by the user through specific software. Thus this process allows continuous monitoring of water level and scour at the bridge site. The installation’s hardware and software design was extensively tested in the laboratory by the UTSA staff before installation in the field. All datalogger software code was developed and tested by the project staff and will be discussed later in this chapter.

HARDWARE CONNECTIONS

Figure 3.1 depicts the schematics for the Phase II installation, showing the new datalogger, communication hardware modem/cellular phone, and pressure transducer.

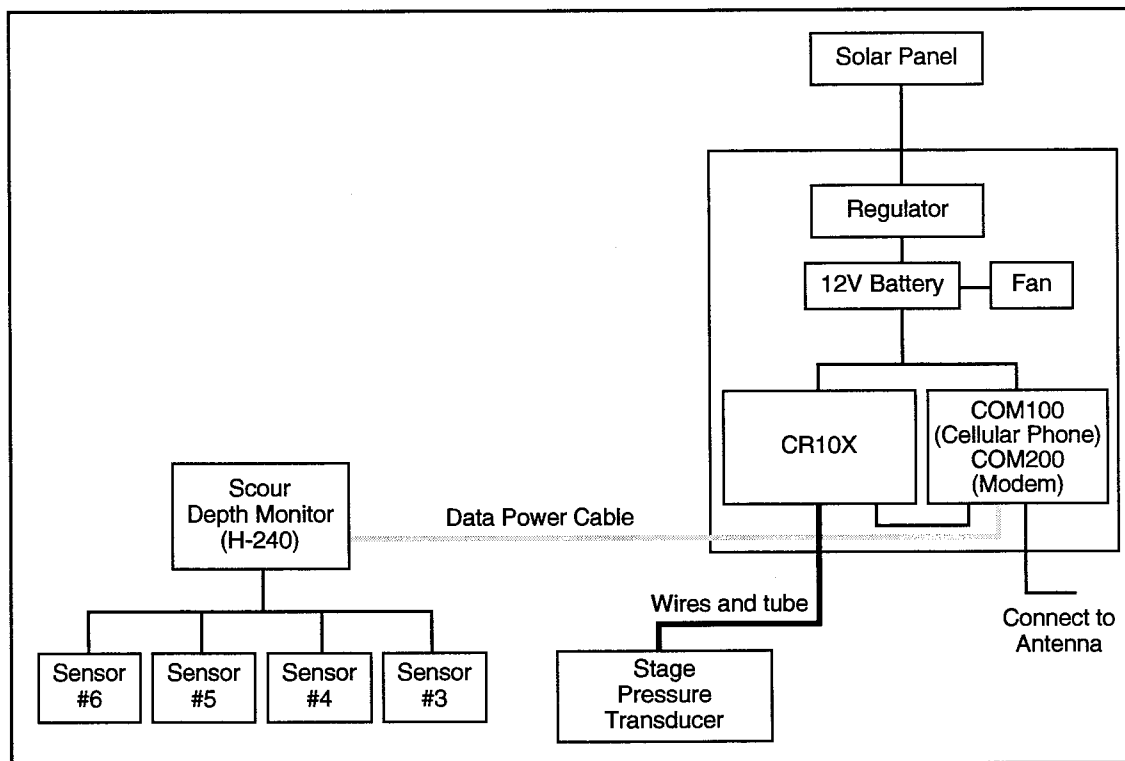

Figure 3.1 Schematics of the hardware installed in Phase II of the pilot installation

Figure 3.2 depicts the wiring panel for the Campbell Scientific CR10X datalogger used in the Phase II pilot installation. The CR10X is a very flexible and powerful datalogger, one that allows for measurements of digital and analog channels and that can control processes (switching devices on and off). It can serve as a platform for controlling multiple

sensors and even for turning flashing beacons on and off. Such versatility renders the CR10X datalogger suitable for applications other than scour monitoring; it could for example be used to monitor and control low-water crossings much like the systems specified in the reports for TxDOT Project 0-1380.

Mounting Hardware and Connections for the H-240 Scour Depth Monitor Unit

As mentioned in Chapter 1, the steel box originally installed between bents number 4 and number 5 was destroyed when it was hit by farm equipment. In an effort to minimize the possibility of further accidents, the Phase II installation at the Mustang Creek site used a redesigned attachment for the steel box containing the H-240 unit, one that increases the distance from the top of the rail. This redesigned attachment is depicted in Figure 3.3, and the installed attachment and box are depicted in Figures 3.4 and 3.5. The square tubing and plates depicted in Figure 3.3 are made of aluminum to decrease weight and to provide corrosion resistance. The handles are steel anodized, available at any hardware store, and allow the assembly to be manually hoisted to the bridge deck for maintenance of the H-240 unit (after unbolting the assembly from the concrete rail).

Figure 3.5 also depicts an overall side view of the Mustang Creek bridge installation, showing the conduits and ultrasonic sensor assemblies, which are the same as those used for the Phase I installation. In addition, Figure 3.5 shows the pressure transducer sensor assembly strapped to pier number 4. A pressure transducer replaced the bubbler sensor used in Phase I of the installation discussed in Chapter 2.

The H-240 SDI-12 protocol depth monitoring unit was tested with the CR10X datalogger and functioned perfectly in the laboratory environment and also in the field at the Mustang Creek site. The H-240 SDI-12 protocol depth monitoring unit is wired to the CR10X datalogger, as summarized in Table 3.1. For a layout of the wiring panel of the CR10X, please refer to Figure 3.2. The fiberglass box containing the H-240 unit, which is mounted inside the steel box attached to the bridge rail, has the three terminals discussed in Table 3.1 clearly marked. The AWG 18 shielded cable used in the Phase I installation was also used in the Phase II installation, saving a significant amount of installation time and human resources.

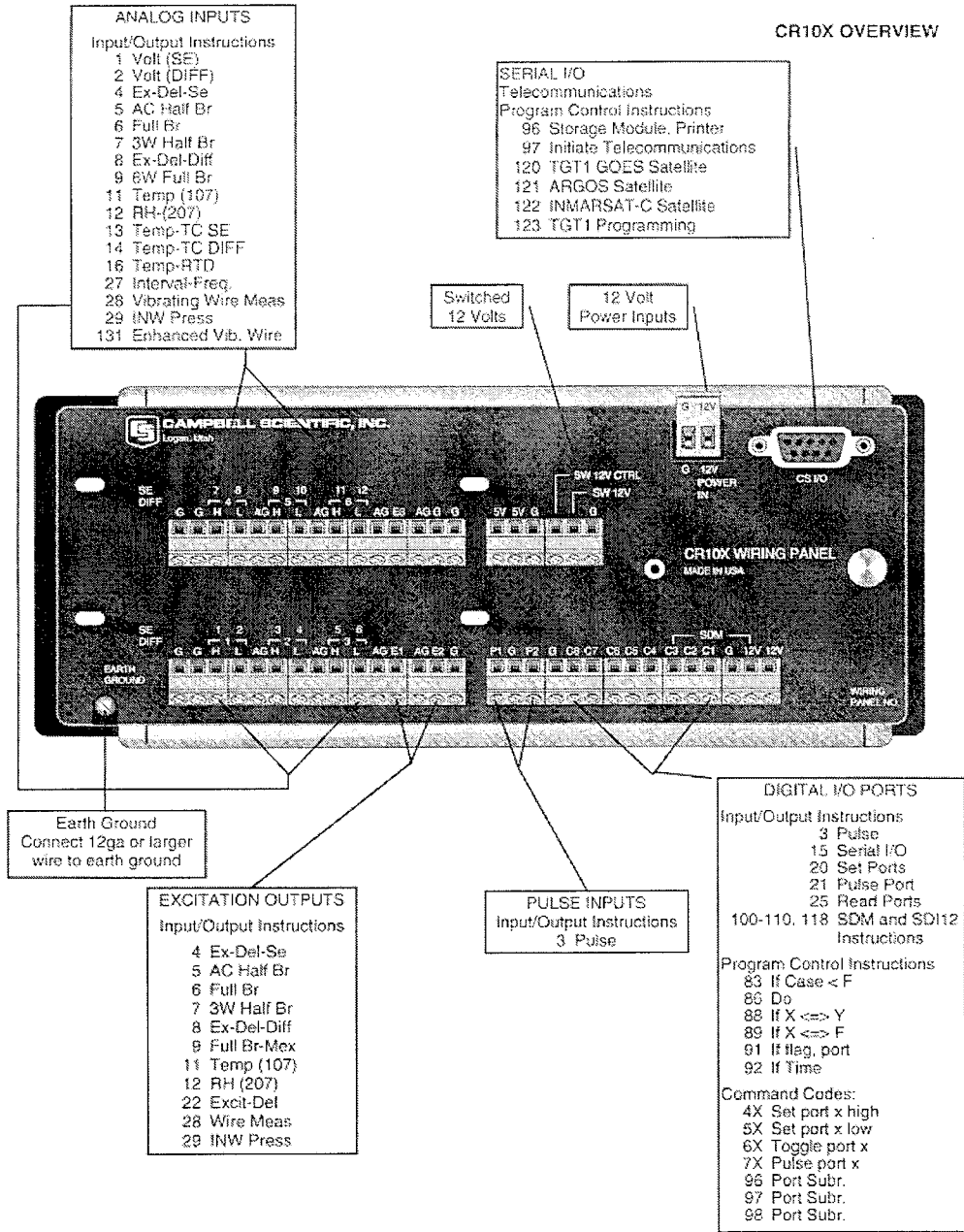

Figure 3.2 Wiring panel for the CR10X Campbell Scientific datalogger

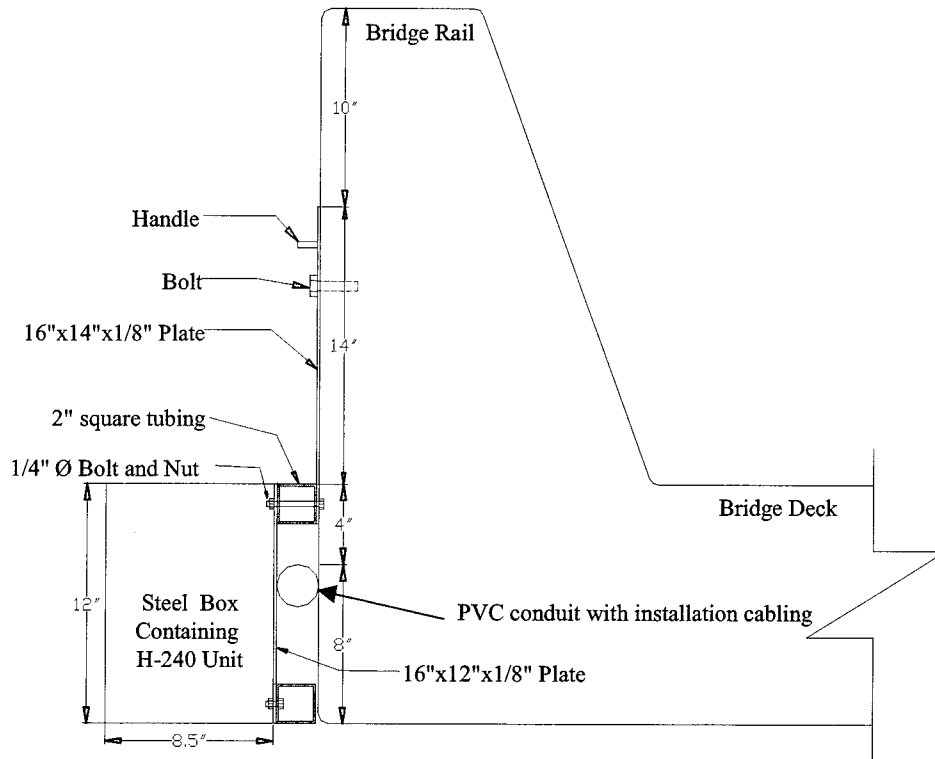

Figure 3.3 Redesigned assembly for the H-240 depth monitoring unit



Figure 3.4 H-240 enclosure and sensor assemblies



Figure 3.5 H-240 enclosure

Table 3.1 Hardware connection between CR10X datalogger and H-240 unit

Possible port on datalogger	Mustang Creek site	On H-240
Any control port, C1 to C8	Used C4	Data Line
Any ground, G	Used G beside P2	Ground
12V output	Used 12V outside SDM	Power

Mounting Hardware for the Stage Pressure Transducer

Figures 3.6, 3.7, and 3.8 show the details of the construction of the pressure transducer's external and internal assemblies. These assemblies are very similar to the assemblies detailed for the Phase I installation and documented in Chapter 2. Some segments from the pressure transducer assemblies are enlarged for details. The dimensions shown are the ones used for the Phase II installation; for other sites these dimensions will change. On the day of the field assembly for the Phase II installation (August 4, 1999), the water level measured from the top of the concrete rail was 12 ft 5 in. The pressure transducer was mounted 4 ft 3 in. below the water surface.

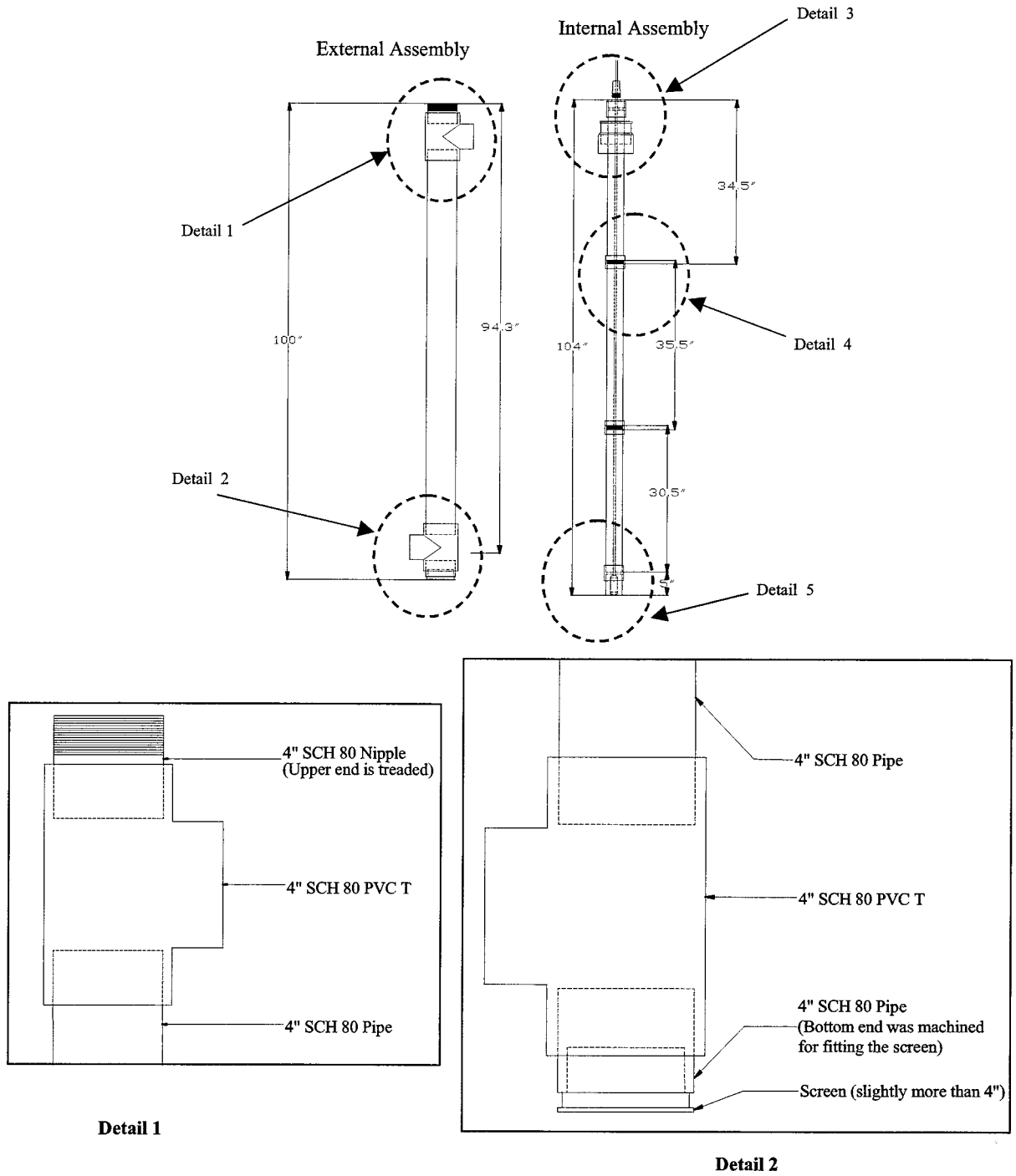

Figure 3.6 Schematics of external and internal assembly for the pressure transducer (Details 1 and 2)

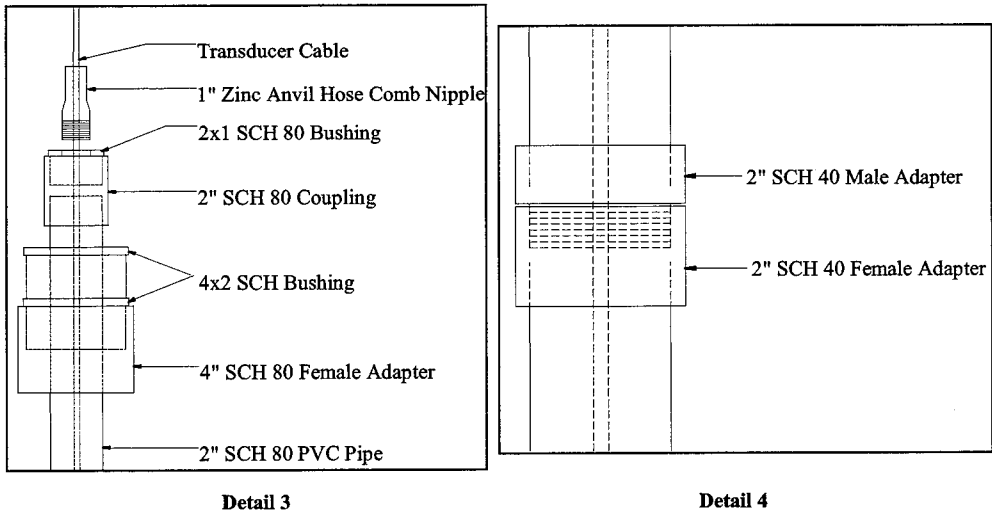

Figure 3.7 Schematics of the pressure transducer assembly (Details 3 and 4)

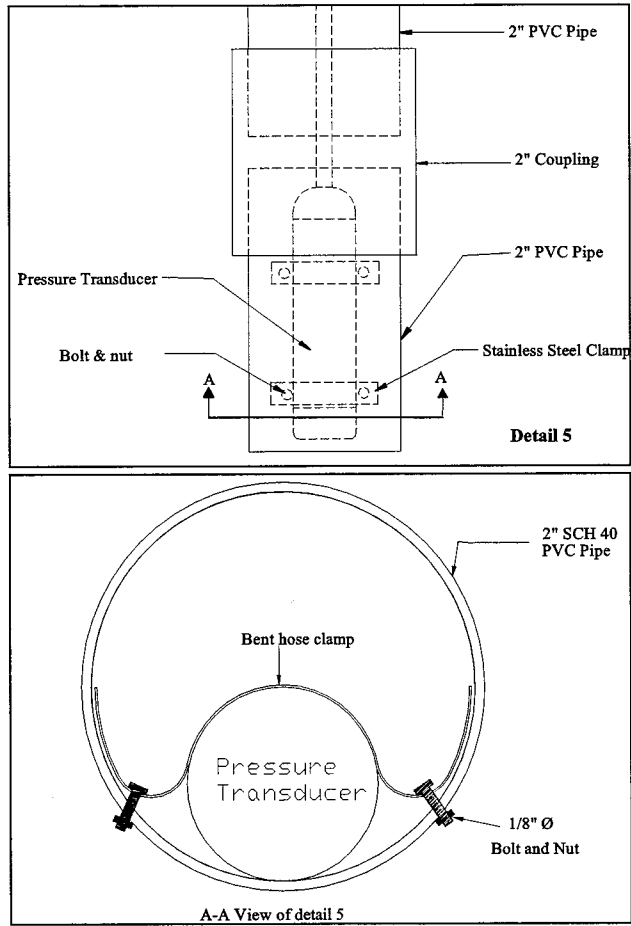

Figure 3.8 Schematics of the pressure transducer assembly (Detail 5)

All the parts for the pressure transducer assembly can be purchased at established plumbing supply stores. A piece of schedule 40 PVC 2 in. pipe had to be machined to fit the drain screen depicted in Detail 2 of Figure 3.6. The number of connections depicted in Detail 4 of Figure 3.7 are dependent on the final length established accordingly with the clearances between the bottom of the bent cap and the average water level. These connections are designed to allow separation of the internal assembly from the external assembly for servicing the pressure transducer at the tip of the internal assembly depicted in Figure 3.8. The field-installed assembly is depicted in Figure 3.4, opposite to the ultrasonic sensor assembly on the second pier depicted in the picture.

Stage Pressure Transducer Electric Connections and Calibration

Figure 3.9 depicts the schematics of the pressure transducer used in the Phase II installation. This is a submersible pressure transducer used in liquid level measurements; was purchased from Campbell Scientific. This transducer uses isolated diaphragm sensors that are specifically designed for use with aggressive fluids and gases. These sensors utilize a silicon pressure cell that has been fitted into a stainless steel package with an integral, compliant stainless steel barrier diaphragm. This sensor assembly is housed in a rugged stainless steel case, which provides for a variety of pressure inputs from 0–15 psi. The unit has surge and reverse polarity protection. A vent filter, actually a capsule containing silica-gel, is used to collect the moisture from the cable vent tube so that the sensitive electronic components will be protected against mildew, corrosion, and rust, which prevent the formation of a liquid column in the vent tube. The pressure transducer is a full Wheatstone-bridge. It is excited by CR10X terminals E1 and AG. Terminals 3H and 3L measure the readings. Details of the software and hardware are detailed in Appendix E, which documents the datalogger software for the Mustang Creek installation.

Figure 3.9 also explains how to connect the different wires to the CR10X wiring panel. Table 3.2 shows in more detail the connections for the pressure transducer with the CR10X datalogger, suggested ports, and ports used at the Mustang Creek site.

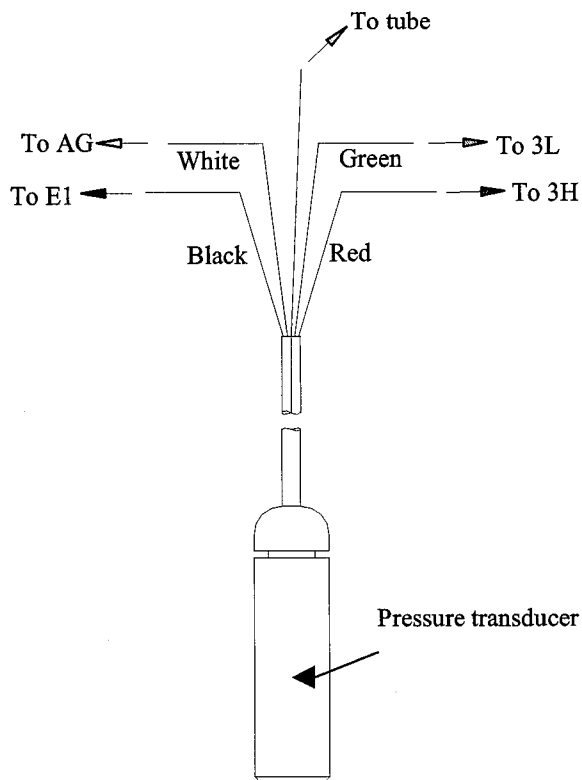

Figure 3.9 Wiring schematics for the pressure transducer

Table 3.2 Wiring schematics for the pressure transducer in Phase II

Possible port on datalogger	Mustang Creek site	In transducer
Any from 1H to 6H	Used 3H	Red wire
Any from 1L to 6L, must combine with one of H ports	Used 3L	Green wire
Any AG	Used AG beside 1L	White wire
Any from E1 to E3	Used E1	Black wire

The sensor was calibrated in the laboratory and presented the calibration curve presented in Figure 3.10. As expected, the calibration curve is a straight line with a slope of 0.415 calculated by the least squares method. Please note that the measurement is scaled directly into feet of water above the transducer, instead of into pressure.

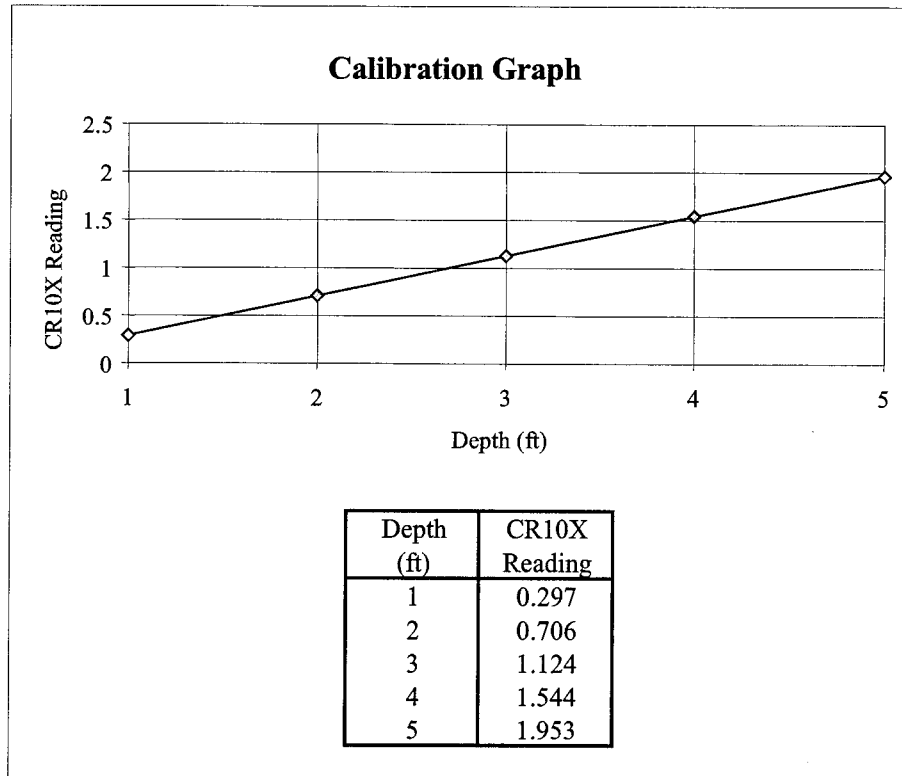

Figure 3.10 Calibration curve for the pressure transducer

Modem Connections

The COM200 is the modem connected to the CR10X that allows the CR10X to connect remotely to an office computer. The COM200 unit is a 9600/1200-baud modem employing the Hayes AT command set. It is powered and enabled by the CR10X datalogger via a blue nine-pin D connector cable connected to the serial I/O port of the CR10X.

The user should note that this is not a standard RS-232 connection. If the user needs to connect the CR10X directly to a computer, this connection needs to be achieved through the Campbell Scientific SC32A optically insulated RS-232 interface. This type of connection may be needed for field testing and programming of the CR10X and for local data downloads.

The COM200 is to be used with analog phone lines only. Referring to Figure 3.11, connect the telephone cable from the RJ11C jack to the RJ11C on the cellular phone package COM100 or a regular land line. (In the Mustang Creek Phase II installation, the modem was connected to a COM100 cellular phone manufactured by Motorola.) The COM200 modem is connected to the CR10X datalogger with a Campbell Scientific (SC12) cable. This connection provides for the RS-232 serial connection and delivers the voltage for operation

of the modem. The grounding terminal (GND) on the COM200 needs to be connected to the ground for the system. Figure 3.11 shows the COM200 modem with the connecting terminals.

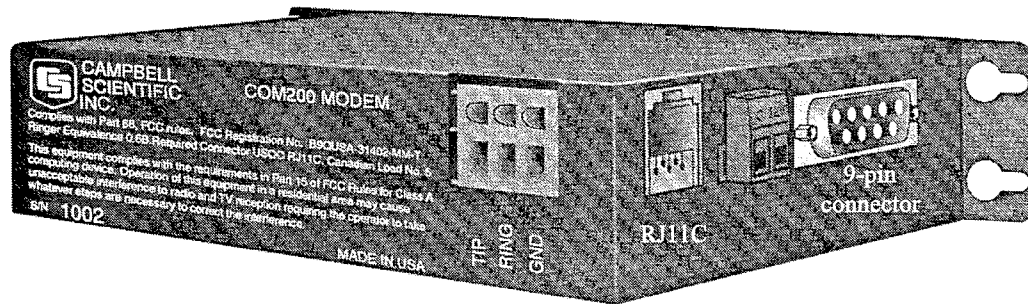

Figure 3.11 COM200 Modem and connecting terminals

Cellular Phone Connections

The COM100 packaged by Campbell Scientific is actually a Motorola cellular phone transceiver. The COM100 unit has an external RJ11C telephone interface to be used in connecting to the COM200 modem. Although the COM100 does not have a handset, any standard analog touch-tone phone can be connected to the RJ11C port to make voice calls if that is needed in the field.

The maximum input voltage for the relay in the connection harness is +9VDC; consequently, it needs to be connected to one of the CR10X control ports that outputs 5VDC to avoid damage to the relay. The green wire in the harness needs to be connected to one of the control ports in the CR10X. This allows the cellular phone to be switched on and off via datalogger software commands, saving a significant amount of current, which is a precious commodity in solar powered applications such as the one at the Mustang Creek site. Datalogger software issues will be discussed later in this chapter and are discussed in detail in Appendix E.

A 50 ohm antenna must be connected to the COM100 at all times. If a call is attempted without an antenna being connected to the COM100, permanent damage can result.

The COM100 needs to be activated before it can be used. The following information and hardware are required at the time of activation.

The Motorola handset to be supplied by the service provider is model SCN2504A or its equivalent. The following information is required for programming by the service provider:

- MFG: Motorola.
- ESN: ED024F8A
- Model: 19370XNMSB
- MSN (Serial #): 327GYA6592B

To establish a connection with a remote cellular phone connected to a CR10X via a COM200 modem, one must enter some software programming settings in the CR10X. These are discussed in detail in Appendix E.

Two common types of antennas are used by this cellular phone. An omnidirectional antenna transmits and receives in any direction. A directional antenna transmits and receives in a particular direction. Since our site was fixed, a Yagi directional antenna, model ASP962, was specified. This model is small, lightweight, and comprised of nine elements; it provides directional coverage in the 806-to-960 MHz range and includes 8dB of gain. This antenna was aimed at a cellular repeater tower close to the Mustang Creek site to receive the strongest signal possible. Table 3.3 summarizes the wiring connections among the cellular phone unit COM100 and the CR10X datalogger, antenna, and COM200 modem unit. The C5 control port activates the relay in the COM100 harness and switches the cellular phone on and off via CR10X software commands.

Table 3.3 Hardware connections for the COM100 cellular telephone

CR10X datalogger	On COM100
C5	Green
12V	Red
G	Black
	Antenna terminal to antenna
	Phone jack RJ11C to modem

Installation of the Completed Back Plate

The back plate with all the hardware was assembled and tested in the laboratory and installed in the existing aluminum box used in Phase I of the Mustang Creek installation. For

details on the installation of the aluminum box enclosure and on such supporting hardware as solar panels and battery, please refer to Chapter 2. Appendix D presents the calculations for checking the existing solar panels and battery. The equipment used in the Phase II installation is less demanding in terms of power consumption than the equipment used in the Phase I installation. The existing power generation and battery from the Phase I installation are more than sufficient to power the different components of the Phase II installation.

Figure 3.12 depicts the back plate for the Phase II installation, as installed in the aluminum box at the Mustang Creek site. From top to bottom, one can observe the battery on the top shelf, the cellular phone COM100 unit, the COM200 modem unit, the CR10X datalogger, and the wiring panel for the power connections. The wiring panel is divided into a right-hand portion for the power connections coming from the battery, and a left-hand portion for data and power connections for the H-240 ultrasonic sensor depth monitoring unit attached to the bridge rail. Toward the bottom left, one can also see the silica-gel cartridge meant to keep the electronics in the pressure transducer dry. This cartridge is connected to the pressure transducer through a long tube that runs together with the electric wiring for the transducer.

Figure 3.13 depicts the aluminum box containing the electronics and battery, the two solar panels, and the directional antenna for the cellular phone unit.



Figure 3.12 Back plate of the Phase II installation

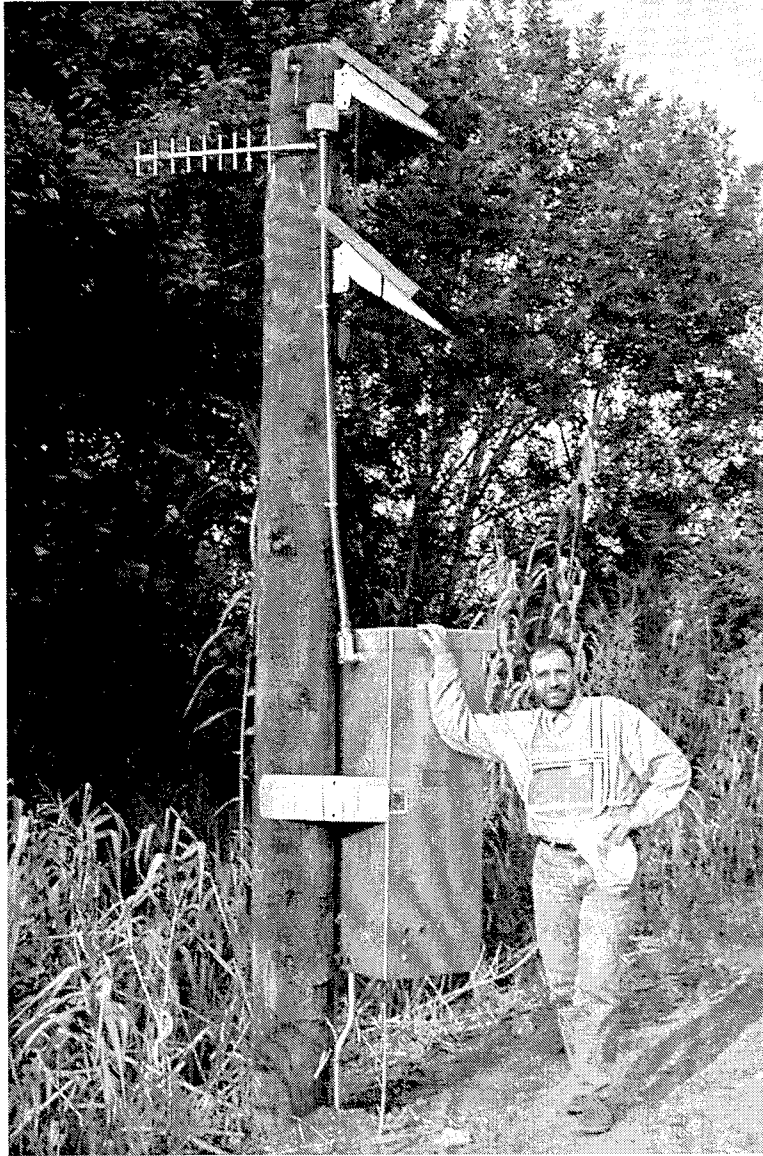

Figure 3.13 Aluminum box, solar panels, and antenna mounted on pole

CR10X DATALOGGER SOFTWARE DEVELOPMENT

The CR10X datalogger used in this installation is fully programmable. The program was written and tested in the laboratory environment to ensure proper functioning of the set-up in the field application. Specific elements in the programming allow for the following actions:

- Sampling the five sensors connected to the datalogger at predetermined time cycles: The program currently installed in the datalogger at the Mustang Creek

site samples all the sensors in intervals of 15 minutes and logs the maximum of the four readings in one hour in a file that can be retrieved remotely.

- Generating alarm calls: If any of the 15 minute readings is above preprogrammed thresholds, the datalogger will generate an alarm call to the office computer with a given ID number. Based on the ID number received, the desktop computer at the office will dial an alphanumeric pager in the possession of a maintenance engineer with a specific alphanumeric message alarm.
- Switching the cellular phone on and off at specific intervals: The program currently installed in the datalogger at the Mustang Creek site will switch the cellular phone on and off at 15 minute intervals, allowing for a total of 30 minutes of “on” time each hour when data can be collected from the datalogger’s permanent memory. This feature was implemented to conserve energy in the field battery.

The communications schematics among the datalogger, the office computer, and the maintenance engineer’s pager are depicted in Figure 3.14.

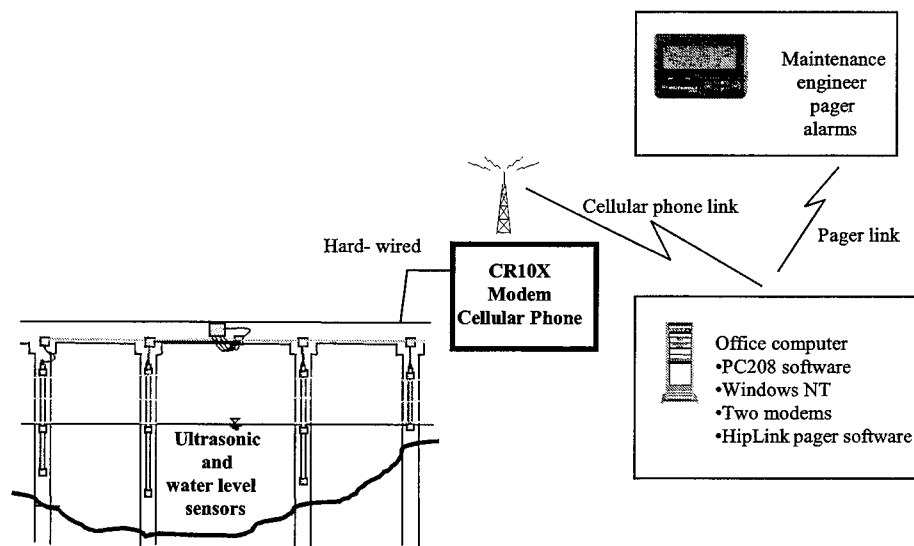

Figure 3.14 Communications schematics for the Phase II installation

Office Computer

The computer at the office needs to meet some minimal specifications. It is recommended that the office computer run under the Windows NT operating system. The office computer also needs to have two modems installed, each with its own dedicated phone

line. The first modem is used to connect with the datalogger, either to collect data or to receive alarm calls. The second modem is used to dial out the alarm calls to the maintenance engineer's pager. To support communications between the office computer and the CR10X datalogger in the field, PC208 software from Campbell Scientific needs to be installed and running in the office computer at all times. For communication between the office computer and a pager to occur, specific software needs to be installed in the office computer. To support the alphanumeric pager link, the project staff tested with success the HipLink software from Cross Communications.

PC208 Setup and CR10X Datalogger Programming

The programming of the datalogger can be changed remotely by downloading a new program through a telephone connection. In order to collect data and update the programming of the datalogger, it is necessary to have a copy of the PC208 software from Campbell Scientific. PC208 provides a user friendly environment for the development and testing of the CR10X software and data retrieval.

PC208W must be loaded and running in the office computer at all times, to make scheduled calls to retrieve data from the remote datalogger, or to receive alarm calls back from the CR10X. PC208W also allows for other DOS or Windows programs to be run when an alarm is received. This feature is particularly useful when one is activating pager software such as HipLink.

The key step in preparing the PC208 software to communicate with the remote datalogger is setting up the device map. The device map provides a pictorial representation of how each device is connected in the communications link. This map provides a hierarchical order in which the devices and tasks are connected. Figure 3.15 depicts the device map for the Mustang Creek Phase II installation.

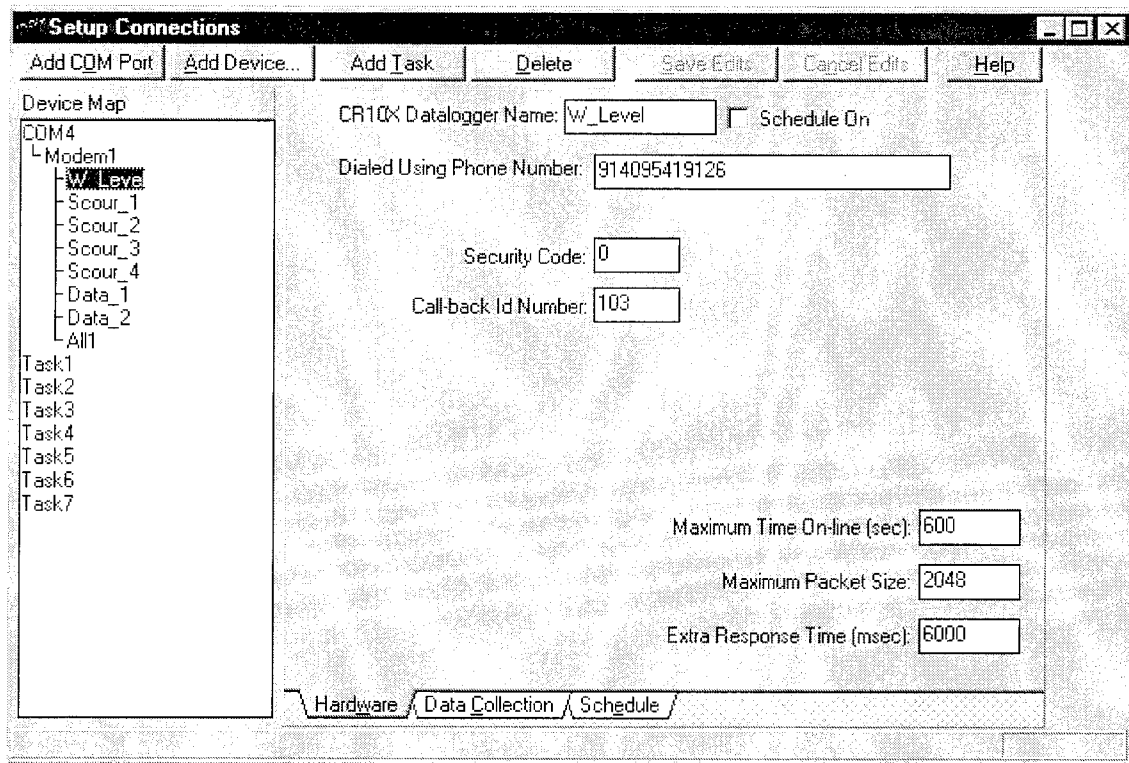

Figure 3.15 PC208 Device map for the Mustang Creek Phase II installation

To set up the above device map, first click on setup in the PC208 datalogger support software.

Click “Add COM Port,” under the hardware tab, and change PC COM Port name to COM4. Please note that in the specific case of our installation, the modem PC 208W uses to communicate with the CR10X datalogger is configured as COM4. Next check the “Allow callback on this port” so that the PC 208 will allow the CR10X datalogger to call back in the event of an alarm. Then, choose the highest baud rate. The highest baud rate for our field modem is 9,600 bps, 4,800 bps being recommended for cellular phone communications. In our case, the baud rate was set to 1,200 bps in order to ensure reliable connections. Data Collection and Schedule tabs are not needed in the modem setup.

Click “Add Device.” Choose “phone modem” and attach it to COM4. Edit the modem setup under the hardware tab as follows: Change the Phone Modem Name to whatever name will be used. In our case, we used Modem 1. Choose the baud rate equal to 1,200 bps. From the Modem Pick List, pick a modem model in your computer that is used to

communicate with CR10X. In our case, we used “US Robotics Sportster 9,600, 14.4, and 28.8 Modem.”

Set the Modem Initialization String for the office computer to auto answer, ATSO=1. This can be set using a terminal emulator program such as Windows-supplied Hyperterminal. ATSO=1 is set so that when the CR10X calls, the modem will pick up the call after the first ring. If too many rings are set up, the datalogger may time out and the callback will not be successful.

Click “Add Device” again. Choose “CR10X Datalogger” and attach it to modem 1. Change “CR10X Datalogger” to whatever name you like. In this case, we used “W_Level,” which is referred to in the datalogger software discussed later. Enter the cellular phone number at the datalogger site. In our case, the phone number is 9-1-409-541-9126; the number 9 was needed to dial out in our office environment. Enter the call-back ID Number equal to 103 for W_Level. This call-back ID will be used by the datalogger software to identify an alarm situation where the threshold for water level was violated. Set 6000 for Extra Response Time. Without the 6 second extra response time, the PC208W may time out before a cellular connection is completed. Click on the Data Collection tab to choose how data is to be collected. Click on the Schedule tab, look for “After Call Do,” and fill in the task you want to perform. For the Mustang Creek installation, Task 1 was assigned to W_Level. Task 1, in this specific case, was programmed to activate a batch file that activates the pager software and sends an alphanumeric pager message describing the emergency situation associated with the water level.

The process for the other variables associated with scour levels is very similar. Click “Add Device” seven times for Scour_1, Scour_2, Scour_3, Scour_4, Data_1, Data_2, and All 1. All of them have to be attached to modem 1. Under the hardware tab, enter the datalogger name (Scour_1, Scour_2, etc.) and phone number (409 541-9126 is the cellular phone number at the Mustang Creek site). Enter callback IDs for all of them except All 1. The call-back IDs for Scour_1, Scour_2, Scour_3, Scour_4, Data_1, and Data_2 are 104, 105, 106, 107, 101, and 102, respectively. The exact same call-back IDs for each of these virtual dataloggers are stored in the initial telecommunication (P97) instruction commands, which are downloaded to the datalogger and are part of the datalogger software discussed in Appendix E. Click on the Data Collection tab and set the data collection preferences. Be sure to enter the correct array ID number for the “Array to collect on 1st call.” Please note that the

exact same array IDs were included in the downloaded datalogger program and that they are used to differentiate data sets from one another. For example, if the W_Level is above the alarm threshold, it will save its value in a section of the field datalogger final storage area that has an array ID equal to 4. During callback, only the data associated with this array will be sent back to the computer. In our case, the array IDs for W_Level, Scour_1, Scour_2, Scour_3, Scour_4, and Data_1, Data_2, and All 1 are 4, 5, 6, 7, 8, 2, 3, and 1, respectively. Data_1 and Data_2 are variables that were used for testing purposes and are not needed for the operation of the Mustang Creek site.

Next, click on the Schedule tab. Type in the task name for After Call Do. In our case, Task 1 is for W_Level, Task 2 to Task 5 are for Scour_1 to Scour_4. Tasks 6 and 7 are for Data_1 and Data_2, respectively.

Click on Add Task under the hardware tab, and enter the task name. Figure 3.16 shows the settings for Task 1, which is associated with the water level threshold alarm. In our case, we used default task names. Next, key in the batch file name, including its path for the "Name of Program to Start." The DOS batch file must contain an executable file that can activate the pager software HipLink commands. For example, in our case, we entered C:\Task1.bat for Name of Program to Start. HipLink commands will be discussed later in the Remote Alarm Notification section. Ignore the Data Collection and Schedule tabs.

Click on "Save Edits." Settings for the PC208 software are complete.

The PC208 software also allows for the development of the program stored in the CR10X datalogger. As discussed before, this datalogger software code controls the data acquisition intervals in the field, stores the information for remote retrieval by the office computer, and generates alarms. It also controls the power management of the cellular phone, which is the highest energy consumer in the field installation. In addition, the code controls the generation of callback alarms to the office computer. The datalogger code for the Mustang Creek site, with comments, is available in Appendix E.

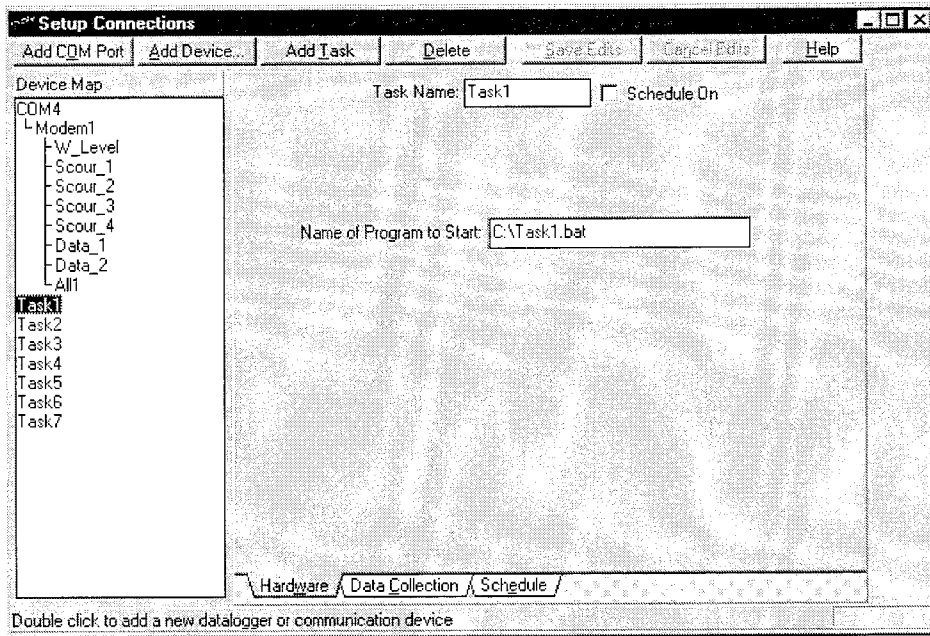

Figure 3.16 Settings for Task 1 alarm notification

Alphanumeric Pager Alarm Notification

When the scour or water levels exceed a preprogrammed critical level (see Appendix E), the datalogger generates a callback to the office computer. The office computer recognizes the call-back ID associated with the callback. After receiving the call, the office computer will activate a task designed for that particular call-back ID. This task is to page and notify the related party with an appropriate message.

For an example, see Figures 3.15 and 3.16. When the office computer receives a call from the CR10X datalogger with a call-back ID equal to 103, the PC208 software in the office computer will automatically match the call-back ID stored in the setup connection with an alarm related to the W_Level (Water Level) variable in the device map and will execute Task 1 as defined in Figure 3.16.

On the Data Collection tab in Figure 3.17, you may notice that after the call-back ID is matched, the datalogger will send data to the office computer and save them in a file called C:\PC208W\W_Level.DAT.

On the Schedule tab in Figure 3.18, in the last row, you will see “After Call Do: Task 1,” which means that after the computer finishes receiving the call, it then activates Task 1. On the Task 1 Hardware tab in Figure 3.16, one can observe “Name of Program to Start:

C:\Task1.bat.” C:\Task1.bat is a batch file that activates the HipLink² pager software. This batch file contains a single line that activates the HipLink pager software and sends an alphanumeric message to a preprogrammed pager or group of pagers. This line reads as follows, where the text is just for illustration purposes:

```
C:\Hiplink\Driver\hlclp -r:AA -m:Water level is critical
please check Mustang Creek site
```

This is a command line interface with the HipLink Driver paging program. It is used to activate the HipLink command and send a page to the pager defined as AA in the HipLink address book.

Tasks 2 through 5 are for the alarms associated with scour levels in bents 3, 4, 5, and 6 at the Mustang Creek site and are defined in a similar way within the PC208 software and for the associated batch files.

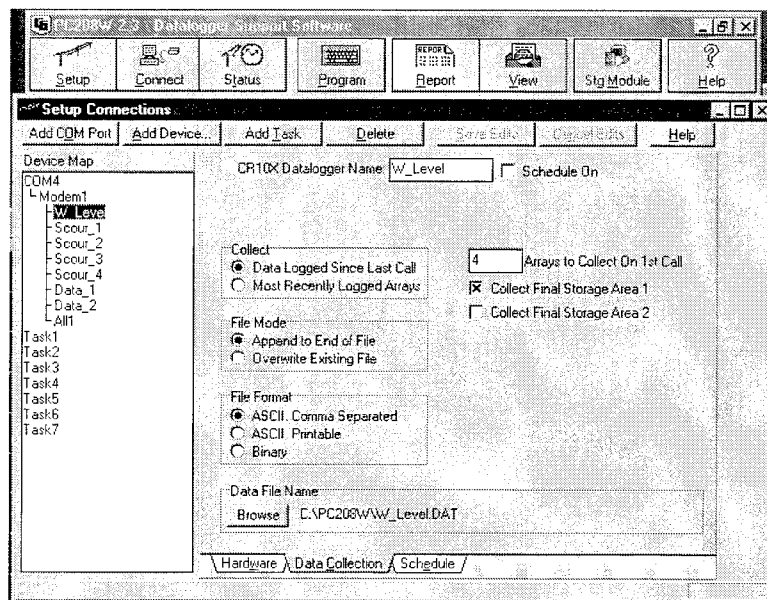

Figure 3.17 Data collection tab for the water level variable

² Cross Communications, Inc., Downers Grove, IL, 60515, phone (630) 964-0800, FAX (630) 964-0924

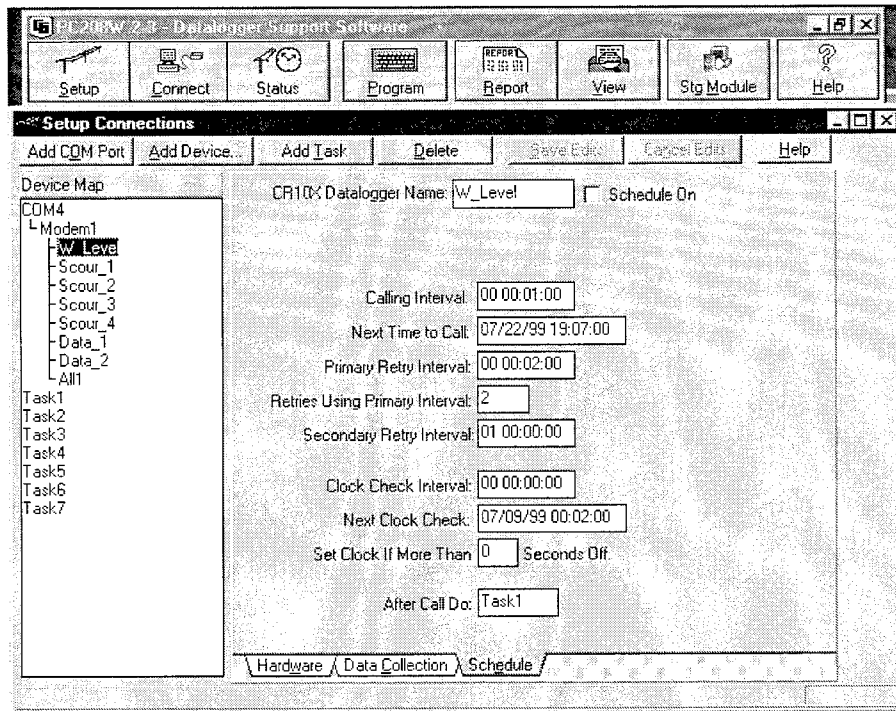

Figure 3.18 Schedule tab for the water level variable

The HipLink Command Line Interface Program (HLCLP) comes with the HipLink Application Messaging Solutions. HLCLP is a program that is called from the tasks defined in PC208. For the HLCLP to operate, the HipLink Driver must be running in the background. The following lines summarize the syntax for the HLCLP.

`c:\HipLink\Driver\hlclp -r:AA -m: "Sample Message."`

Assumes HipLink was installed in `c:\HipLink\Driver`
 AA is a Receiver ID already defined in the User Table.

The text: 'Sample Message' will be sent to AA

Syntax:

`drive:\path\hlclp [parameters] [message|message file]`

Command-line Parameters

- r: Receiver ID of who the message is going to.
- g: Group ID of who the message is going to.
- i: Device ID (pin to the pager).

- n: Network service ID.
- b: Must be added when using Pin and Service (-i and -n) to a numeric pager.

Message to be sent:

- m: "Quoted Message."
- f: A file name containing the message.

Optional Parameters:

- p: Interactive messaging where a window will open to enter all parameters.
- c: Review message on the screen before queuing.
- o: Alternate spool/queue directory (default in \Pages).
- s: Senders ID to associate with message for logging purposes.

Examples:

- a. To an alphanumeric pager or a numeric only beeper defined in the user table:

```
[c:\HipLink\Driver\hlclp -r:CCISUP -m:Test msg to a User defined in User Table]
[c:\HipLink\Driver\hlclp -r:Beep -m:6305551212]
```

- b. To an alphanumeric pager not defined in the user table:

```
[c:\HipLink\Driver\hlclp -i:18009841489 -n:Pagenet -m:Test with alpha not in
User]
```

- c. To a numeric only beeper not defined in the user table; commas are required. Each comma is approximately a 2 second delay:

```
[c:\HipLink\Driver\hlclp "-i:5551212,,," -b -n:Beeper -m:8885551212]
```

- d. To a group of alphanumeric pagers defined in the group table:

```
[c:\HipLink\Driver\hlclp -g:CCI -m:Test msg to a Group defined in Group Table]
```

The communication port for the HipLink Driver in the office computer used during the Phase II installation testing was set up to be COM 2. It is important to note that the office computer needs to have two modems installed. One modem, COM 4 in our setup, is for the

PC208 datalogger software. The second modem, configured as COM 2, exists to support the HipLink paging software.

Figures 3.19 and 3.20 depict some of the setup screens for the HipLink software. Figure 3.19 depicts the Modify Network Service screen. This screen describes the network service parameters for the recipient used during the testing phase and which is associated with the initials AA as used in the batch file discussed previously.

Figure 3.20 depicts the Edit Message Receiver screen, in which the recipient is defined with the initials AA and the network service “Arroyo” is associated with this recipient. When AA is used with the -r parameter in the batch file, the message after the parameter -m will be sent to the receiver defined in Figure 3.20, which has an alphanumeric pager with PIN # 5133195 using the network service that has a phone number (210) 615-7173.

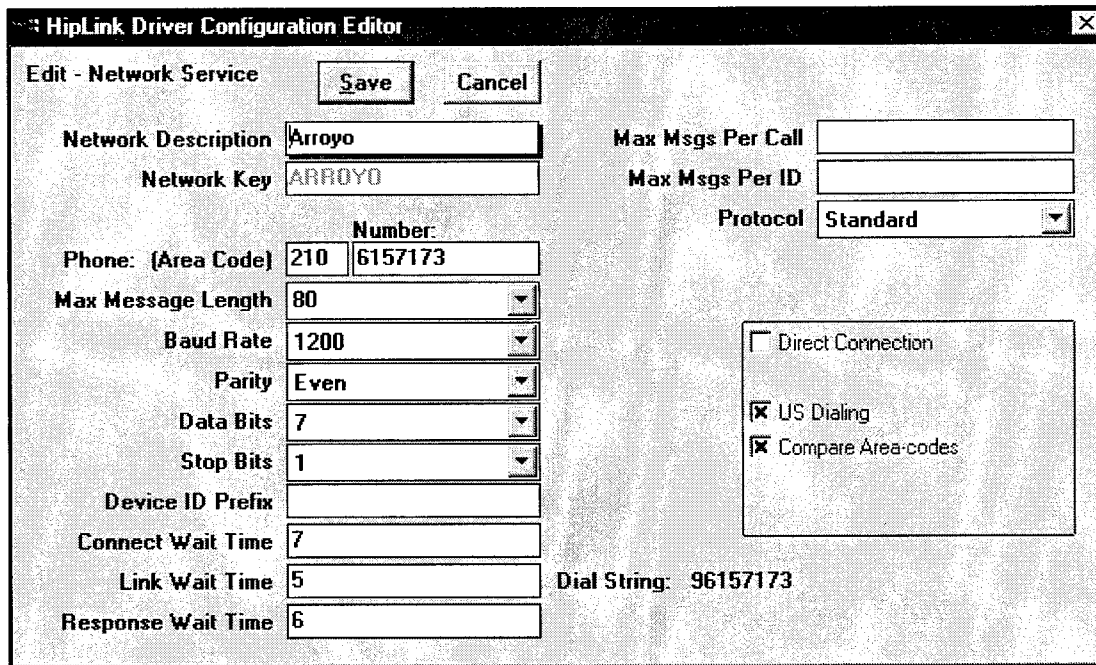

Figure 3.19 HipLink network service setup

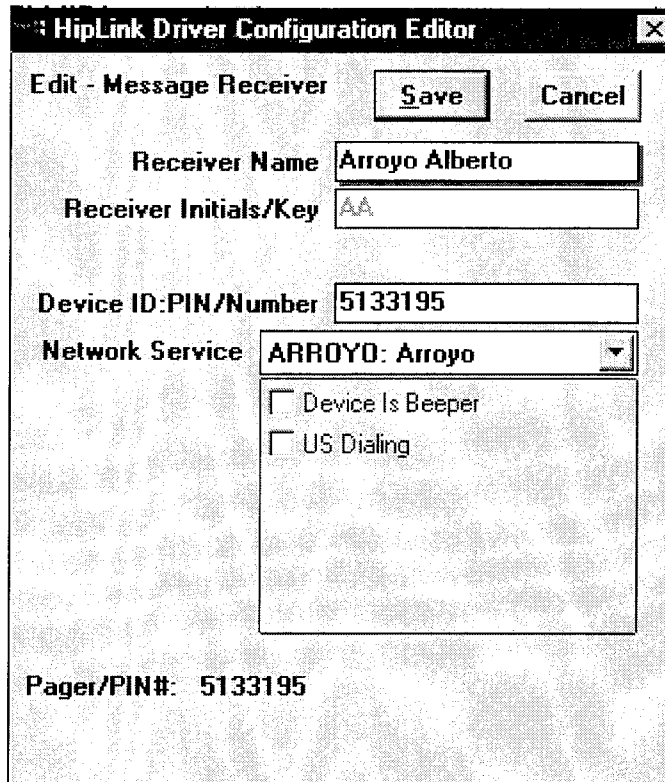

Figure 3.20 HipLink message receiver setup

RETRIEVING DATA FROM THE CR10X DATALOGGER REMOTELY

Data can be retrieved from the datalogger installed at the Mustang Creek site either automatically by the office computer, or with the intervention of the user using the office computer or a laptop computer. In summary, data can be retrieved by any computer correctly set up with the PC208 software.

The maintenance engineer can connect to the Mustang Creek site and retrieve information with a laptop with PC208 properly configured and a modem anywhere access to a telephone line is available. The device map for the laptop computer can be simplified, because it does not contain the alarm notifications, which are provided by the office computer. Figure 3.21 shows a device map for communicating through a hardwired connection to COM 1 in the laptop computer and also through a connection using a modem from a remote location. There is no provision for the tasks associated with the alarms, as was the case for the office computer.

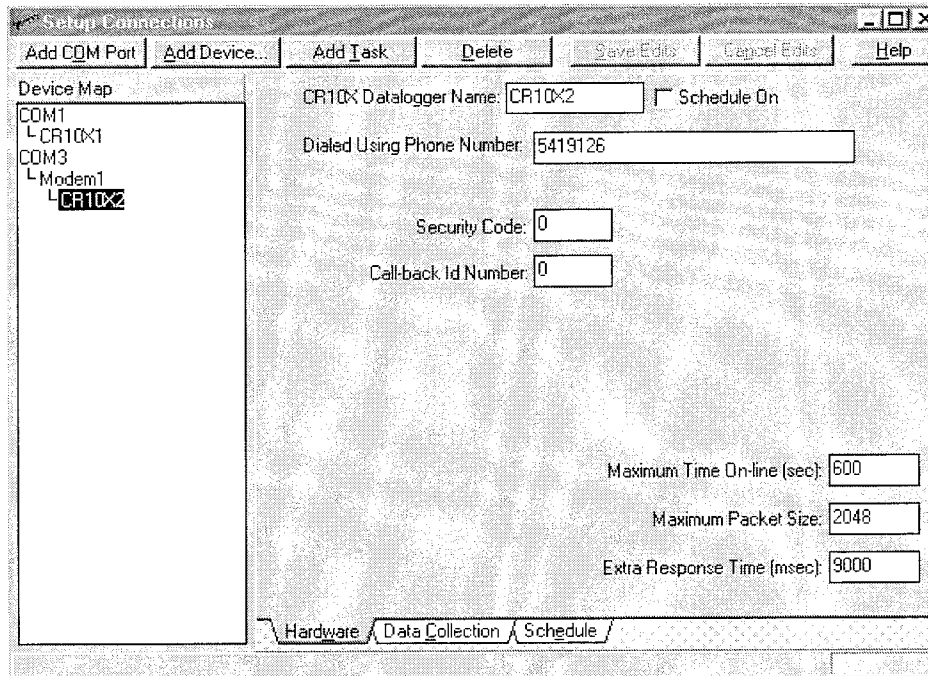

Figure 3.21 PC208 device map for laptop computer

A sample of the data retrieved from the Mustang Creek site Phase II installation is depicted in Table 3.4. These data are available in Excel format from the date of activation, in early August 1999, until August 31, 1999. Table 3.4 depicts the data retrieved and shows in the first three columns the time stamp for when the data was written in the permanent file. In the following columns one can observe the voltage and temperature in Centigrade inside the datalogger; this information is useful for checking the integrity of the solar recharging system and the operating temperature of the system. Next, one can observe the water level with respect to the top of the bridge concrete rail in feet as well as the time within the hour in which the maximum level was observed. The datalogger software, as discussed previously, samples four readings during each hour and logs the maximum value in the file. The eight subsequent columns summarize the readings for the scour level for bents 3, 4, 5, and 6; please refer to Figure 2.14 in Chapter 2 for the layout of the bents. The scour readings measure distances in feet from the ultrasonic sensor head to the creek's bottom. Again, the time for the maximum reading is logged together with the reading. Please note that all times are presented in military time format.

Bent 3 and bent 6 scour data are out of the operating range of the ultrasonic sensors installed at the Mustang Creek site. This means that the distance between the sensor head

and the creek's bed is less than 2 ft, and consequently the sensors in bents 3 and 6 are unable to lock a reading, explaining the reading of zero for these two sensors.

Table 3.4 Sample data for the Phase II Mustang Creek installation

Year	Date	Time	Voltage	Temperature	Water Level	Time of Max.	Bent 3 Scour	Time of Max.	Bent 4 Scour	Time of Max.	Bent 5 Scour	Time of Max.	Bent 6 Scour	Time of Max.
1999	30-Aug	2100	13.05	31.28	-13.02	2015	0	2015	2.4	2045	3.8	2100	0	2015
1999	30-Aug	2200	13.04	29.79	-13.21	2115	0	2115	2.4	2115	3.7	2145	0	2115
1999	30-Aug	2300	13.02	28.73	-13.24	2215	0	2215	2.3	2245	3.6	2230	0	2215
1999	30-Aug	2400	13.01	27.41	-13.29	2345	0	2315	2.3	0	3.6	2315	0	2315
1999	31-Aug	100	13	26.18	-13.31	30	0	15	2.3	15	3.7	100	0	15
1999	31-Aug	200	12.99	25.18	-13.33	145	0	115	2.3	115	3.6	115	0	115

HARDWARE COSTS FOR THE PHASE II INSTALLATION

Table 3.5 summarizes the costs of the additional hardware and software used in the Phase II installation. This list does not include the ultrasonic transducers and H-240 SDI-12 interface that were recycled from the Phase I installation and that have an estimated cost of \$3,000. The HipLink software was obtained from Cross Communications as an evaluation copy. The estimated cost for the HipLink software is \$400. The cost of a properly configured Windows NT workstation is also not included but should not exceed \$2,000. One office computer is able to monitor several scour monitoring sites.

Table 3.5 Costs of the hardware and software used in the Phase II installation

CR10X	128K Module and Wiring Panel Datalogger	\$ 1,090.00
PC208W	Windows Datalogger Software	\$ 285.00
SC32A	Optically Isolated RS-232 Interface	\$ 145.00
CS400L	Keller 169 Depth Transducer With:	\$ 466.00
	200 Ft Of Polyurethane Signal Cable	\$ 386.00
	100 Ohm Shunt Resistor Assy.	\$ 22.00
	0 To 15 PSI Pressure Range	
COM100	Motorola Cellular Phone Package With:	\$ 655.00
	Yagi Asp962 8db Antenna	\$ 150.00
	Com200 Phone Modem	\$ 375.00
	Total	\$ 3,574.00

AUTOMATIC MAGNETIC SLIDING-COLLAR SPECIFICATIONS AND LABORATORY TESTING

The hardware and software for an automatic sliding-collar assembly to be connected to the CR10X Campbell Scientific datalogger were tested preliminarily in the laboratory.

Unfortunately, owing to time constraints in the project, the proposed assembly was not included in the Phase II field installation.

Hardware for Automatic Magnetic Sliding-Collar Installation

The automatic sliding-collar sensor assembly consists of a series of Reed switches assembled at predetermined spacings. Reed switches, which can be purchased from established electronic component suppliers, work by closing a circuit when in the proximity of a magnetic field. In this case, the magnetic sliding collar slides along a stainless steel pipe that is driven in the riverbed as a scour hole develops during a flood event. As the magnetic collar slides, it closes the Reed switches inside the stainless steel pipe, allowing a datalogger properly connected to the sensor assembly, and with the proper programming, to detect the position of the magnetic sliding collar. The datalogger may also detect whether the sliding collar passed through a given Reed switch and when. The main interfacing device between the Reed switch assembly and the CR10X datalogger is a Campbell Scientific SSDM-SW8A switch closure module.

Several SDM-SW8A switch closure modules from Campbell Scientific are needed to serve as an interface between the Reed switch assembly and the CR10X datalogger. Each SDM-SW8A switch closure module can monitor eight Reed switches, and up to four SDM-SW8A units can be connected in series to a CR10X datalogger, allowing thirty-two Reed switches to be monitored. Spacing the Reed switches in the magnetic sliding-collar assembly at 1 ft increments allows potential scour holes of more than 32 ft to be monitored. Figure 3.22 depicts the connection panel of the SDM-SW8A switch closure module. Figure 3.23 depicts the connections between several SDM-SW8A switch closure modules and the CR10X and an optional power supply (the dashed line represents a connection directly to the CR10X with no optional power supply). The Reed switches are assembled in a circuit board and arranged with the desired amount of space, e.g., 1 ft, between them. One common ground wire attaches to one connector of each of the Reed switches. The other connector on each of the Reed switches needs to be attached to the appropriate channel in the SDM-SW8A module. Reed switches can be purchased from Tech America (Part #9005884). Tech America can be reached at 1-800-877-0072.

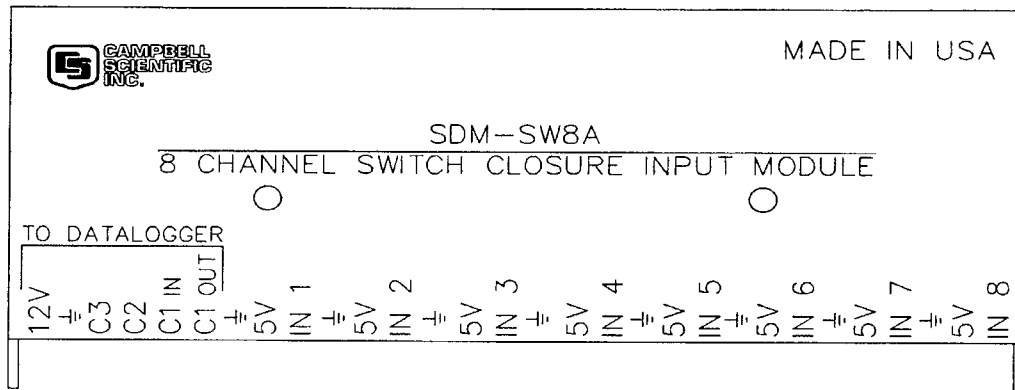

Figure 3.22 Connection panel of the SDM-SW8A switch closure module

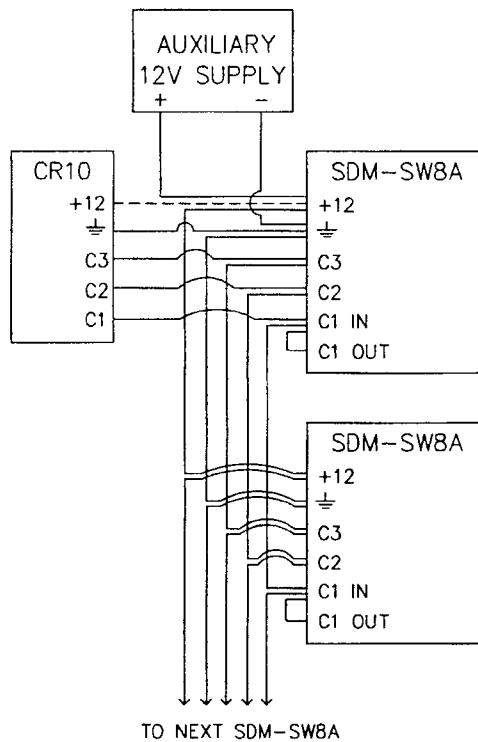

Figure 3.23 Schematics for connecting several SDM-SW8A switch modules to a CR10X

Software for Automatic Magnetic Sliding-Collar Installation

Alarms can be generated in a way similar to that for the ultrasonic installation, using the HipLink software and callback IDs generated by the CR10X datalogger, when certain levels of scour are detected by the automatic magnetic sliding collar assembly. Appendix F contains the CR10X software code for detecting the position of a magnetic sliding collar

exciting a twenty-four Reed switch assembly. This code was tested in the laboratory with success.

Figure 3.24 depicts the schematics of a hybrid magnetic sliding-collar ultrasonic installation. This installation allows the monitoring of mixed types of sensors such as ultrasonic sensors and magnetic sliding collars.

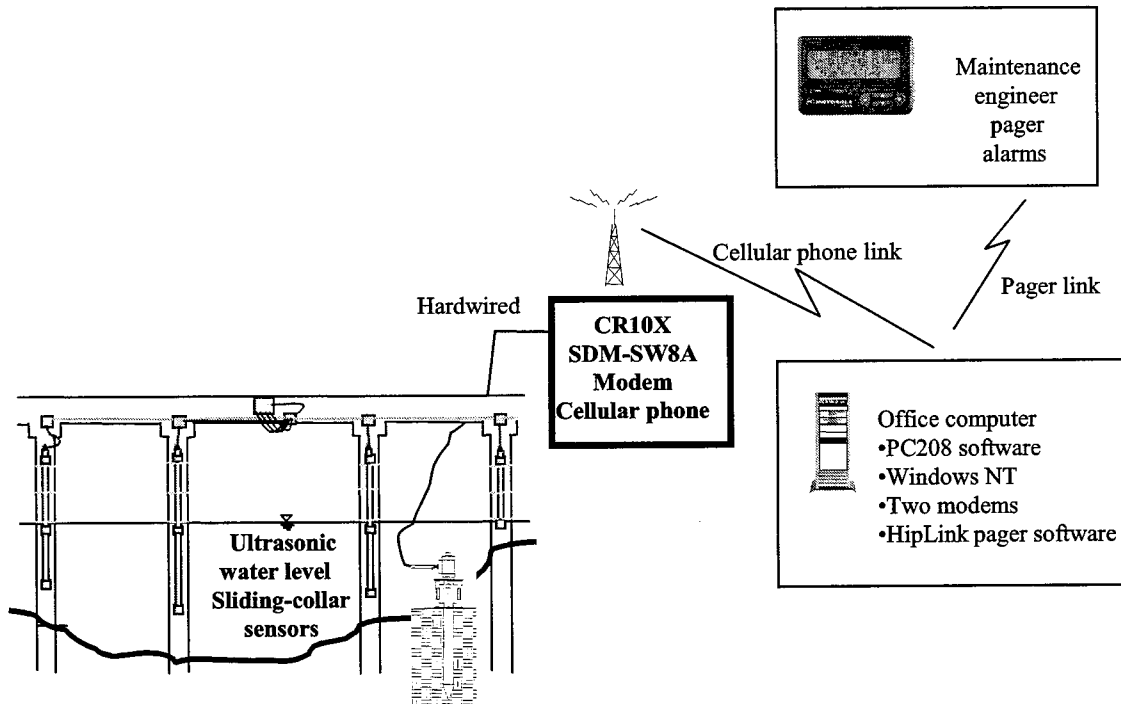

Figure 3.24 Schematics of a hybrid magnetic sliding-collar ultrasonic installation

CHAPTER 4. SUMMARY AND RECOMMENDATIONS FOR FURTHER RESEARCH

SUMMARY

This project researched the state of the art of monitoring scour development at bridge foundations remotely by using fixed installations. The two most widespread sensors available for monitoring bridge scour — ultrasonic sensors and magnetic sliding collars — were addressed by this research project.

A pilot installation was implemented at the Mustang Creek bridge crossing on FM 1157 in the Yoakum District, Jackson County, Texas. This pilot installation was developed in two phases. Phase I used a rather limited datalogger that did not have the ability to monitor a hybrid sensor site involving ultrasonic and magnetic sliding-collar sensors. It also lacked the ability to generate alarm calls to an office computer. The Phase I installation consisted of four ultrasonic sensors mounted on four different bridge piers. Researchers had access to the scour and stage data remotely through a cellular phone and modem installed at the site. The site was powered by a battery and solar panel installation.

The project staff designed all the sensor assemblies and the wiring connections for the installation and installed the site with the help of a TxDOT crew during the summer of 1998. The site was operational and produced reliable data on scour levels until March 1999. Around the middle of March 1999 the ultrasonic interface unit box attached to the concrete rail was hit by farm equipment and destroyed.

The project staff was already working on the design and testing of an improved system with a more flexible datalogger for a second pilot installation. This effort was then directed toward getting the Mustang Creek site operational again, and it became Phase II of the Mustang Creek installation. The Mustang Creek site was again operational with the Phase II pilot installation late in the summer of 1999.

The Phase II installation benefited from the research effort that was being carried out during the second year of the project. Phase II installed a more powerful datalogger at the Mustang Creek site using the same ultrasonic sensors and sensor assemblies installed during Phase I. Phase II also took advantage of most of the existing wiring and solar power installation of Phase I. In addition, Phase II installed an improved combination of cellular telephone and modem, which improved communications with the site significantly.

The Phase II datalogger has the ability to monitor multiple and different types of sensors, such as pressure transducers for stage and ultrasonic and magnetic sliding-collar sensors for scour. This is a fully programmable datalogger that has the ability to generate alarm calls to an office computer when certain pre-programmed thresholds for stage and scour are reached. The project staff also successfully tested automatic paging software residing in an office computer that is able to generate alarm calls to alphanumeric pagers carried by TxDOT maintenance staff, based on alarm callbacks from the datalogger in the field.

RECOMMENDATIONS FOR FUTURE RESEARCH

The hardware and software combination developed by this research project for the Phase II installation at Mustang Creek can be easily adapted for the monitoring of low-water crossings. Almost exactly the same hardware and software setup, with a redesigned pressure transducer assembly, can be used at low-water crossings to monitor water levels and generate alarms when certain thresholds are reached. The datalogger used in the Mustang Creek Phase II installation also has the ability to control flashing beacons at low-water crossings and even to operate physical barriers to the traffic automatically when pre-programmed water level thresholds are reached.

Information from multiple scour monitoring sites and low-water crossing sites can be easily integrated by an office computer server and even published on the Internet with the appropriate combination of hardware and software.

This research project specified and tested the basic hardware and software for monitoring scour remotely at bridge sites. However, it is recommended that additional scour monitoring sites be implemented, allowing for field testing of an automatic magnetic sliding-collar installation, which was not tested at the Mustang Creek pilot site.

Finally, larger bridges with extremely high piers may translate into more challenging installations owing to the limits on wiring lengths for data transmission from the sensors to the datalogger. These larger bridges can be monitored for scour by using a system of wireless local radio connections at the site to connect the sensors and the site's datalogger.

APPENDIX A:
**SOLAR PANEL AND BATTERY SELECTION FOR THE PHASE I
INSTALLATION**

APPENDIX A: SOLAR PANEL AND BATTERY SELECTION PHASE I

SOLAR PANEL SELECTION

1. Determine the electrical current consumption rate in both standby mode and active mode for each of the pieces of electrical hardware. Manufacturers may provide most of this information. If not, set up the circuit and measure the current consumption as shown in the figure below. Note that to measure the current, the multi-tester has to be connected in a series to measure the current consumption. The most demanding equipment in this installation is the cellular phone modem combination, especially during transmission mode.

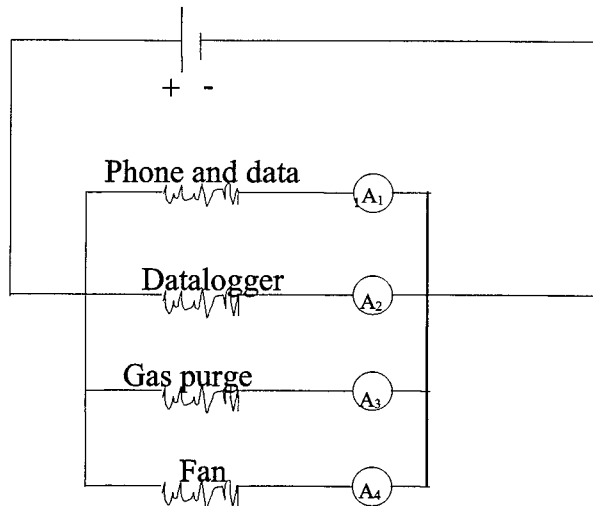

Figure A.1 Schematics for measuring amperage consumption of equipment

2. Determine the period when each component is in active mode.
3. For standby mode, total current consumption is the product of the total current drawing rate in standby mode and 24 hours. For active mode, the total current consumption is the sum of the products of the current drawing rate in active mode and the active period for each of the electrical components.
4. The total current consumption is the sum of the total current consumption in standby mode and active mode.
5. Determine the minimum power recharge rate of the solar panels available.
6. Assume the shortest recharging period (shortest day in winter).
7. Determine the total recharge for one day. It is the product of the shortest recharging period and the minimum power recharge rate.
8. Compare the total power recharge with the total current consumption.

9. Select the solar panel for which the total power recharge is greater than the total current consumption.

AVERAGE CURRENT DRAW IN STANDBY MODE

Mitsubishi telephone with data modem	=	150 mA
H-350 Datalogger in sleep mode	=	20 mA
H-355 gas purge system in sleep mode	=	30 mA
Average current draw in standby mode	=	200 mA
Total current draw in standby mode in one day	=	4.8 AH

ADDITIONAL CURRENT DRAW IN ACTIVE MODE

Equipment	Current	Length of Operation (assumed)	Total
Phone	$A_1 = 0.25 \text{ A}$	0.5 hr	0.125 AH
Datalogger	$A_2 = 0.07 \text{ A}$	2.0 hr	0.140 AH
Gas purge system	$A_3 = 1.00 \text{ A}$	1.5 hr	1.500 AH
Fan	$A_4 = 0.55 \text{ A}$	3.0 hr	1.650 AH

Total additional current draw in active mode = 3.4 AH

Total current draw in one day = 7.2 AH

POWER RECHARGE RATE

Maximum current output for smaller solar panel	=	0.95 A
Maximum current output for larger solar panel	=	1.97 A
Maximum recharge current available	=	2.92 A

These figures assume 8 hours of maximum sun energy are available in Texas in one day during the winter, and the efficiency of recharging is 33 percent.

Total recharge power = $0.33 \times 8 \times 2.92$ = 7.7 AH

Total current consumption = 7.2 AH < Total recharge power = 7.7 AH

BATTERY SELECTION

In selecting the battery, we must be conservative. Only 50 percent of a battery capacity should be drained in 5 days (5 consecutive rainy days) without recharging.

If the average current drawing rate = 7.2 AH per day

Then total current draw in 5 days = $7.2 \text{ AH} \times 5 = 36 \text{ AH}$

The battery capacity $\geq 36 \text{ AH} \times 2 = 72 \text{ AH}$

To be on the safe side, the battery selected by the group was a 100 AH gel-cell battery.

Note: A gel-cell battery is preferable because it does not generate corrosive fumes that may be harmful to the electronics inside the aluminum box installed at the site.

**APPENDIX B:
PHASE I DATALOGGER MENUS**

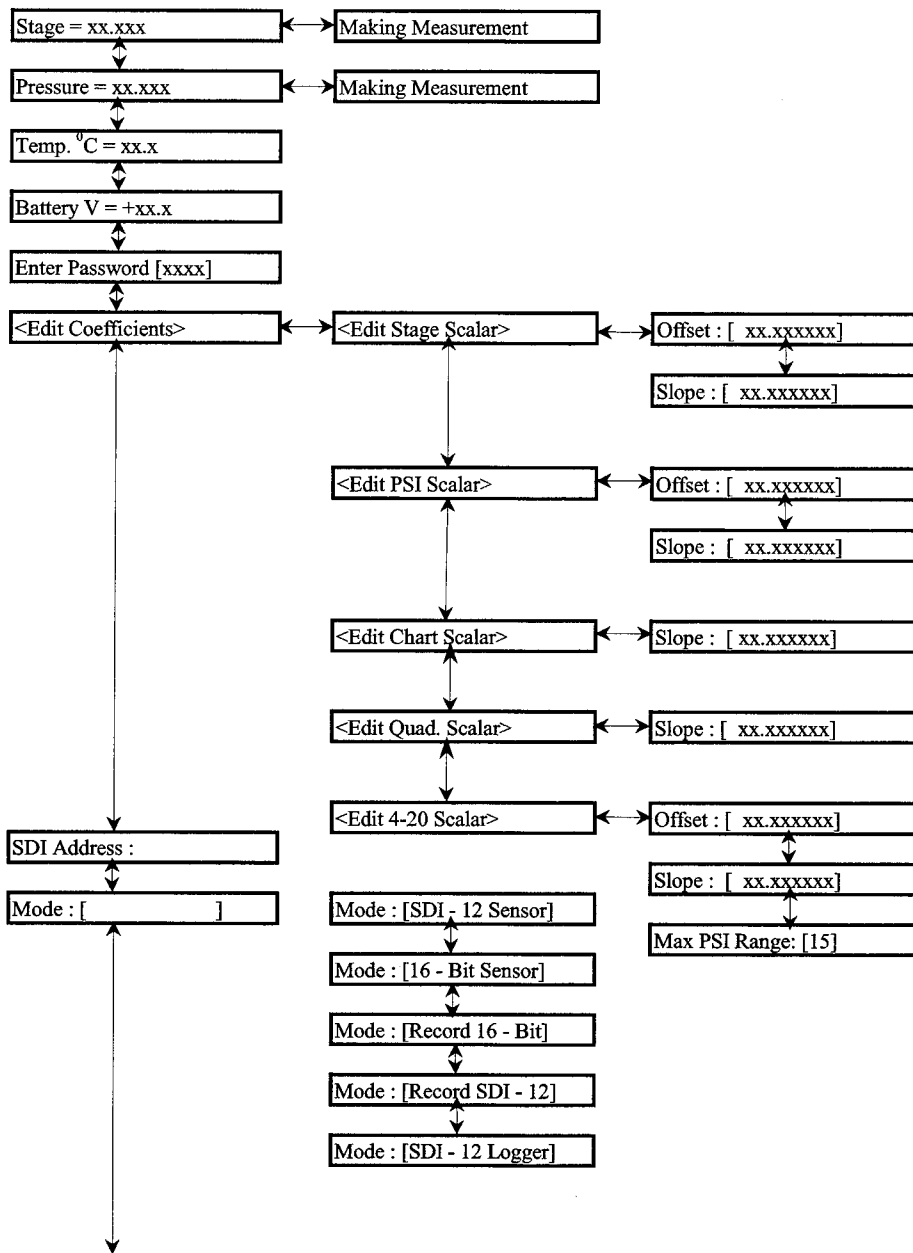

Continue to the next page

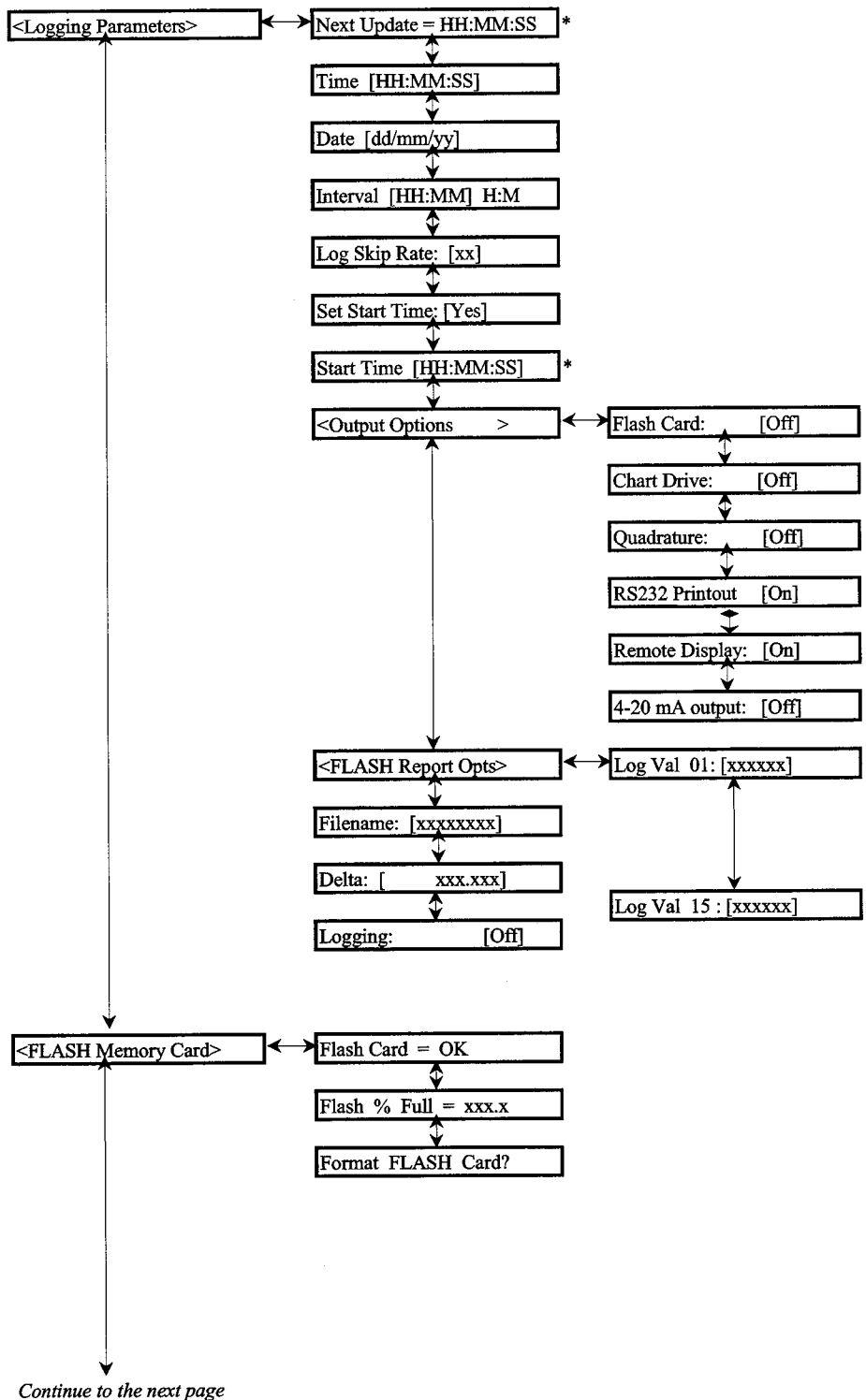

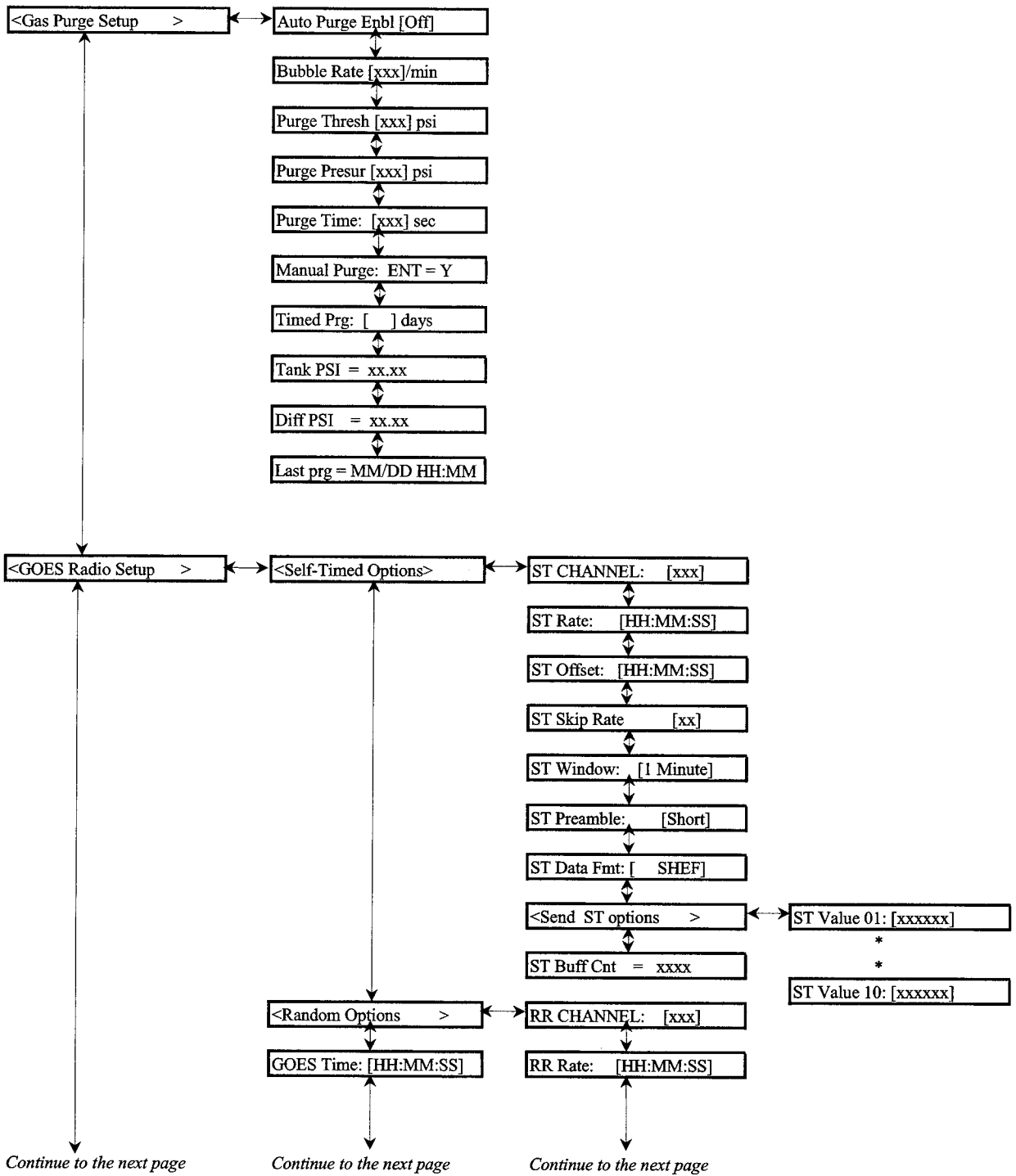

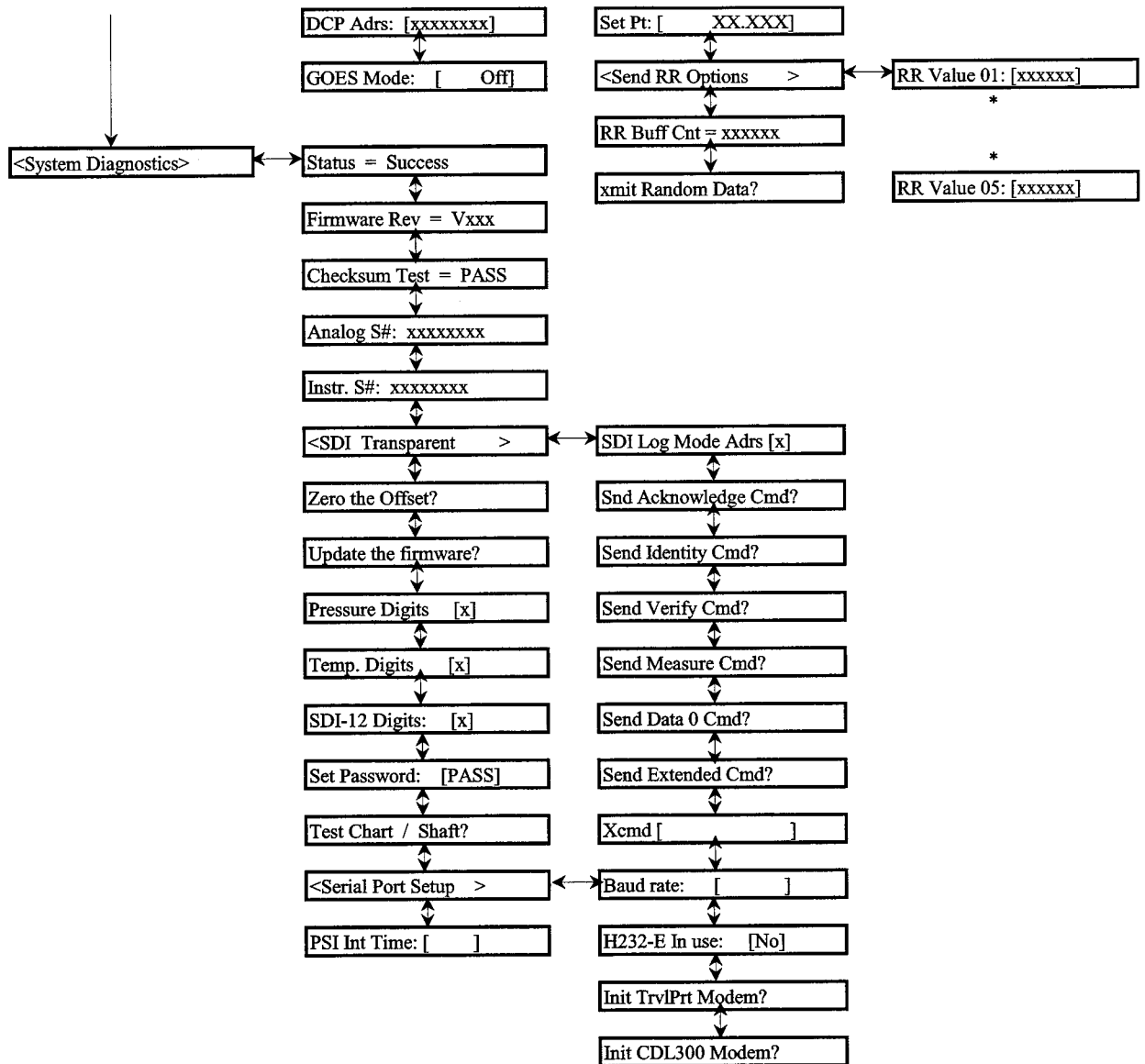

*The presence of these menu items is dependent on system settings

APPENDIX C:
PHASE I COST INFORMATION

<i>Material Description</i>	<i>Supplier</i>	<i>Unit Price</i>	<i>Quantity</i>	<i>Total Cost</i>
<u>Equipment Needed</u>				
1. Ultrasonic Sensor with 75' cable	Design Analysis Inc.	Lump Sum	4	\$5,000
2. Sonar Depth Unit			1	
3. Data Logger			1	
4. Bubbler Unit			1	
5. Gas Purge System			1	
6. Solar Penal (MXS-20)			1	
7. Cell Phone with built-in Modem			1	
8. Antenna	Southwestern Bell Mobile, TX	\$35	1	\$35
9. Shielded Cable	Sherman Electronics, TX		1 roll	\$65
10. Gel-Cell Battery	Excide Co.	\$80	1	\$80
<u>Parts Required</u>				
1. 4" PVC SCH 80 Pipe	San Antonio Pipe Supplies, TX	\$33/20ft	80 ft	\$132
2. 4" PVC SCH 80 T	San Antonio Pipe Supplies, TX	\$9.79	21	\$206
3. 4" PVC SCH 80 Nipple	San Antonio Pipe Supplies, TX	\$6.80	5	\$34.00
4. 4" PVC SCH 80 Female Adapter	San Antonio Pipe Supplies, TX	\$18.02	5	\$90.10
5. 2" PVC SCH 80 Pipe	San Antonio Pipe Supplies, TX	\$0.75/ft	20 ft	\$15
6. 4x2 PVC SCH 80 Bush	San Antonio Pipe Supplies, TX	\$8.91	5	\$44.55
7. 2" PVC SCH 80 Coupling	San Antonio Pipe Supplies, TX	\$2.04	10	\$20.40
8. 2" PVC SCH 80 Female Adapter	San Antonio Pipe Supplies, TX	\$5.90	5	\$29.50
9. 2x1 PVC SCH 80 Bush	San Antonio Pipe Supplies, TX	\$0.69	5	\$3.45
10. 1" Zinc Anvil Hose Comb Nipple	San Antonio Pipe Supplies, TX	\$1.28	10	\$12.80
11. 4x2 PVC SCH 40 Bush	San Antonio Pipe Supplies, TX	\$4.50	5	\$22.50
12. 2" SCH 40 PVC Pipe	Home Depot, TX	\$3.69/10 ft	5	\$18.45
13. 4" PVC SCH 80 Cape	San Antonio Pipe Supplies, TX	\$2.67	5	\$13.33
14. 2" SCH 40 Coupling	San Antonio Pipe Supplies, TX	\$0.75	3	\$2.25
15. Oatey Heavy Duty PVC Cement	San Antonio Pipe Supplies, TX	\$10.00	2	\$20.00
16. 3/4" Flex Conduit	Home Depot, TX	\$1.00	50	\$50
17. 3/4" Liquit-tight connector	Home Depot, TX	\$5.00	12	\$60
18. 1" Heavy Duty Hose	Austin Distrib. & Manuf., TX			\$60
19. 1" Heavy Duty Hose Clip	Home Depot, TX	\$1.00	12	\$12
20. Silicone Sealant	Home Depot, TX	\$4.25	2	\$8.50
21. Junction Box	Home Depot, TX	\$9.99	6	\$59.94
22. Caulk Gun	Home Depot, TX	\$1.56	1	\$1.56

<i>Material Description</i>	<i>Supplier</i>	<i>Unit Price</i>	<i>Quantity</i>	<i>Total Cost</i>
23. 1/8 x 1" Screw	Home Depot, TX	\$3.50	1 box	\$3.50
24. 5/16 x 3" Screw	Home Depot, TX	\$1.00	6	\$6.00
25. 1" PVC Conduit	Home Depot, TX	\$25.00	50ft	\$50.00
26. O-ring and Gasket	Home Depot, TX	\$1.00	1	\$1.00
27. 4-term Strip	Radio Shack	\$1.57	2	\$3.04
28. Teflon Tape	Home Depot, TX	\$0.97	3	\$2.91
29. Gel-Cell Battery (12V, 100AH)	Exide, TX	\$80.00	1	\$80.00
30. AWG 12 Weather Proof Cable	Wesco, TX	\$0.60/ft	50ft	\$30.00
31. Solar Panel (MSX-40)	Solarex, TX	\$250	2	\$500
32. Aluminum Tubing (3" Sq.)	Westbrook Metal, TX	\$7.37/ft	10ft	\$73.70
33. Aluminum Splice	Westbrook Metal, TX	\$10/ft	2.5ft	\$25
34. 5/16" x 4" & 2" Hex Bolt, Nub, and Washer	Alamo Bolt, TX		}	\$40.74
35. 5/16" x 3/4" Hex Bolt and Washer	Alamo Bolt, TX			
36. Band-it Stainless Steel Strapping	Alamo Iron Work, TX	\$46.90/roll	2 rolls	\$93.80
37. Band-it Tool	Alamo Iron Work, TX	\$77.39	1	\$77.39
38. Buckle	Alamo Iron Work, TX	\$33.69/box	1 box	\$33.69
39. Aluminum Cabinet	TxDOT	\$1,102	1	\$1,102
40. Back Plate	TxDOT	-	1	
41. D. C. Fan	Grainger, TX	\$19.92	1	\$19.92
42. Temperature Thermostat	TxDOT	-	1	
<u>Manpower and Equipment Rental</u>				
1. Snooper Rental	TxDOT		} Lump Sum	\$2,000
2. TxDOT Crew for 2 days	TxDOT			\$500
3. Van Rental and Fuel, Aug. 15 to Aug. 22	Capps, TX			\$400
4. Van Rental and Fuel, Sept 17 to Sept. 20	Enterprise, TX			\$200

Total Cost = \$11,194

Note : This total cost does not include the research time, trial materials, and UTSA manpower and facilities.

APPENDIX D:
**SOLAR PANEL AND BATTERY SELECTION FOR THE PHASE II
INSTALLATION**

APPENDIX D: SOLAR PANEL AND BATTERY SELECTION PHASE II

POWER SUPPLY REQUIREMENT FOR THE SYSTEM

Average Current Draw in Standby Mode:

CR10X = 1 mA
 COM 100 (half day only) = 0.5 mA
 COM 200 = 0.12 mA

Average current draw in standby mode = 0.00137 A
 Total current draw in standby mode in one day = 0.00137 * 24 = 0.033 AH

Additional current draw in active mode:

Equipment	Current	Daily time (assumed)	Total (Ampere *Hour)
CR10X Data Logger	0.59 A	8 hr	4.72 AH
COM 100	1.8 A	0.5 hr	0.9 AH
COM 200	0.14 A	0.5 hr	0.07 AH
H-240	Included in CR10X	1 hr	
Sonar Sensor	Included in CR10X	1 hr	
Fan	0.55 A	Not drawing in winter	

Total additional current draw at active mode = 5.69 AH
 Total current draw in one day = 5.72 AH

Battery Selection

Assuming that only 50 percent of the battery capacity can be drained in 5 days without recharging (5 consecutive rainy days).

Average current drawing rate = 5.72 AH per day

Total current draw in 5 days = 5.72 AH x 5 = 28.6 AH

Battery capacity \geq 28.6 AH x 2 = 57.2 AH

The battery at the site is an 85 AH Gel Cell Battery for 20-hour rate capacity and 150 minutes reserve capacity. This battery was purchased from Exide Co., 550 Springfield Road, San Antonio, Texas 78219. Tel: (210) 662-8999

Solar Panel Sizing

Power recharge rate:

Maximum current output for smaller Solar Panel at site	=	0.95 A
Maximum current output for larger Solar Panel at site	=	1.97 A
Maximum recharge current available	=	2.92 A

These figures are based on 8 hours of sun energy available in Texas in one day during the winter, and the efficiency of recharging 33 percent.

$$\text{Total recharge power} = 0.33 \times 8 \times 2.92 = 7.7 \text{ AH}$$

$$\text{Total current consumption} = 5.72 \text{ AH} < \text{Total recharge power} = 7.7 \text{ AH}$$

APPENDIX E:
COMMENTED SOFTWARE CODE FOR THE CR10X DATALOGGER
INSTALLED AT THE MUSTANG CREEK SITE

APPENDIX E: COMMENTED SOFTWARE CODE FOR THE CR10X DATALOGGER INSTALLED AT THE MUSTANG CREEK SITE

Programming and sensor wire connection

```
:{CR10X}
```

```
;
```

```
*Table 1 Program
```

```
01: 900 Execution Interval (seconds)
```

CR10X will execute the Table 1
Program every 900 seconds (15 min).

Cell Phone

1: If time is (P92)

```
1: 0 Minutes (Seconds --) into a
```

```
2: 30 Interval (same units as above)
```

```
3: 45 Set Port 5 high
```

This command turns the cellular phone
transceiver on and off.

At midnight, the cell phone will be
powered up.

The interval is 30 minutes.

Its power relay cable is connected to and
controlled by Port 5. High means on.

2: If time is (P92)

```
1: 15 Minutes (Seconds --) into a
```

```
2: 30 Interval (same units as above)
```

```
3: 55 Set Port 5 low
```

At 30 minutes after midnight, the cell
phone will be switched off.

The interval is 60 minutes.

Low means switch off the transceiver.

The two instructions above turn the cell
phone on and off at 15-minute intervals.

Caution:

We recommend that the cell phone
power control instructions (the two)
above be placed ahead of other
instructions, so that in case of alarm, the
instruction for the alarm would not be
affected by the "Set Port 5 Low"
instruction until the next execution of
Table 1 Program. This also allows the

user to have time to call the datalogger after receiving the alarm.

**** Warning:**

If the downloaded program does not include an instruction to switch the transceiver on, it will be necessary to visit the site and reprogram the datalogger to set a control port on high before resuming cellular communication.

For the two instructions above, if the value in parameter 2 is less than the value in parameter 3, the receiver will not power up.

Battery

3: Battery Voltage (P10)

This instruction measures the voltage of the external power source.

1: 2 Loc [Bat_Volt]

The measured value will be saved in input location 2 (Bat_Volt).

Temperature

4: Internal Temperature (P17)

This instruction (P17) measures the temperature (°C) of a thermistor on the CR10X analog board.

1: 3 Loc [CR10XTemp]

The measured value is saved in input location 3 (CR10X Temp).

This value is used as a reference temperature for the next instruction (P14).

This instruction (P14) calculates the thermocouple temperature for the thermocouple type selected. It measures the differential voltage on a thermocouple and adds it to the reference voltage measured in

5: Thermocouple Temp (DIFF) (P14)

- 1: 1 Reps
- 2: 21 2.5 mV 60 Hz Rejection Range
- 3: 5 DIFF Channel
- 4: 1 Type T (Copper-Constantan)
- 5: 3 Ref Temp (Deg. C) Loc [CR10XTemp]
- 6: 4 Loc [Temp]
- 7: 1.0 Mult
- 8: 0.0 Offset

instruction P17 relative to 0 °C, then converts the combined voltage to temperature in °C.

There is one thermocouple to measure, so enter 1 for Reps.

Differential channel 5 is used. It reads the voltage difference between high and low inputs of a differential channel. Both high and low must be within $\pm 2.5V$ of the CR10X's ground.

Thermocouple used is Copper-Constantan.

The reference temperature is input location 3 (CR10X Temp).

Final temperature value is saved in input location 4 (Temp).

Leaving Mult = 1 and Offset = 0 will keep the reading unit in °C.

Water Level

A submersible pressure transducer is used in the water level measurements. It is actually a full Wheatstone bridge. The transducer has a diaphragm, which changes in position when it is subjected to water pressure. The strain gauge in the Wheatstone bridge monitors the amount of water pressure. You can study the following sketch for better understanding.

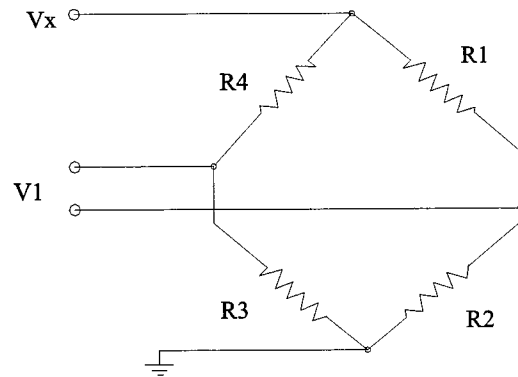

Datalogger will record the value

$$X = 1000(V1/Vx)$$

$$X = 1000(R3/(R4+R3) - R1/(R1+R4))$$

For a parallel circuit, the voltage drop caused by R1 and R2 must be equal to the voltage drop caused by R4 and R3, which equals $V_{N1} - V_{N0}$.

The pressure transducer was calibrated on June 21, 1999.

Gradient = 2.4154 ft

Y-intercept = 0.28

Please read the following before connecting the pressure transducer wires to the CR10X Panel.

Connect the Red wire to 3H,
the Green wire to 3L,
the White wire to AG beside
3L, and
the Black wire to E1.

6: Full Bridge (P6)

1: 1 Repts
2: 3 25 mV Slow Range

P6 is an instruction for water level measurement.

3: 3	DIFF Channel	Use differential channel 3 on the datalogger panel to measure V1.
4: 1	Excite all reps w/Exchan 1	Use E1 as the excitation channel.
5: 770	mV Excitation	Use 770 mV for excitation. You can use a smaller voltage. It won't affect the result.
6: 5	Loc [W_Level]	The reading X multiply by gradient and add to offset will be saved in W_level.
7: 2.4154	Mult	The gradient of the curve on calibration chat is 2.4154.
8: -16.4	Offset	The offset from the calibration chat is 0.28. You can set a reference datum and make use of this offset. In our case we used the top of the bridge rail as a datum, and the distance between the datum and the sensor is 16.7 ft. Thus you can set a new offset equal to 0.28-16.7 = -16.4 . Now the water levels below the top of the bridge rail will be negative values, and the water levels above the rail will be positive values.

Check the Water Level

Now we are going to check the water level to see whether it is above a threshold danger level. In our case the alarm level was set to be triggered if the water level was greater than or equal to -7.5 ft from the top of the rail. If it is less than the alarm level, the datalogger will ignore the instructions start from If to instruction 17: End.

7: If (X<=>F) (P89)

1: 5	X Loc [W_Level]
2: 3	>=
3: -7.5	F
4: 30	Then Do

This is a conditional command (P89) If the W_Level is greater than or equal to negative seven and one-half feet, the datalogger will perform the following instructions.

8: Do (P86)

1: 45 Set Port 5 High

First, it turns on the cell phone transceiver by setting the port 5 high, in preparation of sending an alarm.

At least 15 seconds are needed to stabilize the power before a call can be placed. The power relay of the cell phone transceiver is controlled by port 5 on the datalogger panel. We will not include any instruction to power the transceiver down since we may want to call the datalogger from the office after we have been notified by the alarm.

9: Excitation with Delay (P22)

1: 3 Ex Channel
2: 0 Delay W/Ex (units = 0.01 sec)
3: 1500 Delay After Ex (units = 0.01 sec)
4: 0000 mV Excitation

This instruction is to delay the execution of the next instructions.

Delay for 15 seconds.

10: Do (P86)

1: 10 Set Output Flag High (Flag 0)

This instruction sets the flag 0 high so that the input location W_Level can be saved into the final storage location.

11: Set Active Storage Area (P80)

1: 1 Final Storage Area 1
2: 4 Array ID

This instruction sets the final storage area and array ID for W_Level. During call back, W_Level will be sent to the server computer in the office.

12: Sample (P70)

1: 1 Repls
2: 5 Loc [W_Level]

This instruction samples the W_Level from the input location into the final storage location.

13: Do (P86)

1: 23 Set Flag 3 Low

This instruction sets the Flag 3 low to activate the telecommunication command immediately afterward.

14: Initiate Telecommunications (P97)

1: 21 Phone Modem/1200 Baud
2: 3 Disabled when User Flag 3 is High
3: 120 Seconds Call Time Limit

This one and the next one are the instructions used to perform the telecommunications.

The call is timed from the start of the instruction until a valid ID number is received by the CR10X. In our experiments, a 120-second time limit is the minimum if a cellular phone is used. If you set the call time limit to less than 120 seconds, it may time out before the connection between the CR10X and the server computer is made.

4: 150 Seconds Before Fast Retry
5: 2 Fast Retries
6: 5 Minutes before Slow Retry
7: 14 Failures Loc [Fail_3]
8: 103 Call-back ID

Once the connection is established, the datalogger will send the call-back ID to identify itself to the PC208W in the office computer. Then the office computer will send back the same ID to finish establishing a valid link. PC208W will then activate the corresponding tasks associated with the call-back ID, such as activating the HipLink pager software to send a note to the related parties and warn them about the dangerous condition.

This instruction (P63) is used immediately after instruction 97. We used two P63 instructions to enter our laboratory phone number, 1-210-458-5595, because the office computer was in the laboratory at the time. This number should be changed to the

TxDOT office computer managing the site.

15: Extended Parameters (P63)

1: 1 Option
2: 2 Option
3: 1 Option
4: 0 Option
5: 4 Option
6: 5 Option
7: 8 Option
8: 5 Option

16: Extended Parameters (P63)

1: 5 Option
2: 9 Option
3: 5 Option
4: 13 Option

Must insert 13 at the end of the phone number to tell datalogger to execute the call back.

5: 00 Option
6: 00 Option
7: 00 Option
8: 00 Option

17: End (P95)

This is the end of the loop that checks the water level.

Scour measurement

The SDI-12 H-240 interface is used with ultrasonic sensors to measure scour level. Wire connections are as follows: white wire from H-240 is connected to Port 4 on datalogger panel. Red and black wires are connected to any +12V and Ag, respectively. These can also be connected directly to the battery.

18: SDI-12 Recorder (P105)

1: 0 SDI-12 Address
2: 0 Start Measurement (aM0!)
3: 4 Port
4: 6 Loc [Scour_1]

5: 1.0 Mult
6: 0.0 Offset

19: If (X<=>F) (P89)

1: 6 X Loc [Scour_1]
2: 3 >=
3: 6 F
4: 30 Then Do

20: Do (P86)

1: 45 Set Port 5 High

This instruction is to measure scour. Distance from the sensor heads to the riverbed for the four sensors. The default SDI-12 address for the H-240 is 0.

Scour_1 or input location 6 is the first input location to be used by the SDI-12 reading. This is the scour measurement in bent #3. We have four SDI-12 readings here, and each of them is saved into an input location starting from the input location Scour_1 and numbered sequentially. For example, Scour_1 is saved in input location 6, Scour_2 is saved in input location 7, Scour_3 is saved in input location 8, and Scour_4 is saved in input location 9. Multiplier and offset are not used, and the raw data is recorded.

Check Scour_1

Instruction P89 checks whether scour condition is above a dangerous level.

If the input location 6 (Scour_1) is greater than or equal to a fixed value of 6 (feet), then complete the following instructions before the End instruction 29: (P95) is met.

Turn the cell phone on.

21: Excitation with Delay (P22)

- 1: 3 Ex Channel
- 2: 0 Delay W/Ex (units = 0.01 sec)
- 3: 1500 Delay After Ex (units = 0.01 sec)
- 4: 0000 mV Excitation

Wait for 15 seconds.

If you do not understand the following instructions, you can always go back to see the similar instructions in the “Check Water Level” segment of the code.

22: Do (P86)

- 1: 10 Set Output Flag High (Flag 0)

23: Set Active Storage Area (P80)

- 1: 1 Final Storage Area 1
- 2: 5 Array ID

These instructions store the Scour_1 data in Location ID 5. During call back this information will be sent to the office computer.

24: Sample (P70)

- 1: 1 Reps
- 2: 6 Loc [Scour_1]

25: Do (P86)

- 1: 24 Set Flag 4 Low

When flag 4 is low, the datalogger will initiate telecommunications.

The following are telecommunication commands.

26: Initiate Telecommunications (P97)

- 1: 21 Phone Modem/1200 Baud
- 2: 4 Disabled when User Flag 4 is High
- 3: 120 Seconds Call Time Limit
- 4: 150 Seconds Before Fast Retry
- 5: 2 Fast Retries
- 6: 5 Minutes Before Slow Retry
- 7: 15 Failures Loc [Fail_4]

8: 104 Call-back ID

27: Extended Parameters (P63)

1: 1 Option

2: 2 Option

3: 1 Option

4: 0 Option

5: 4 Option

6: 5 Option

7: 8 Option

8: 5 Option

These instructions are used to enter the phone number for the datalogger to dial out.

The phone number of the laboratory where the office computer was during the experiment is (210) 458-5595. This number should be changed to the number of the TxDOT office computer managing the site.

28: Extended Parameters (P63)

1: 5 Option

2: 9 Option

3: 5 Option

4: 13 Option

5: 00 Option

6: 00 Option

7: 00 Option

8: 00 Option

29: End (P95)

Check Scour_2 (This is the scour level in Bent #4)

30: If (X<=>F) (P89)

1: 7 X Loc [Scour_2]
2: 3 >=
3: 3 F
4: 30 Then Do

If Scour_2 is greater than or equal to a fixed value of 3 (feet), then do the following before the 41: End instruction.

31: Do (P86)

1: 45 Set Port 5 High

32: Excitation with Delay (P22)

1: 3 Ex Channel
2: 0 Delay W/Ex (units = 0.01 sec)
3: 1500 Delay After Ex (units = 0.01 sec)
4: 0000 mV Excitation

The transceiver must be on at least 15 seconds before the call is placed.

33: Do (P86)

1: 10 Set Output Flag High (Flag 0)

34: Set Active Storage Area (P80)

1: 1 Final Storage Area 1
2: 6 Array ID

These instructions store the Scour_2 data in Location ID 6 of Final Storage Area 1.

36: Sample (P70)

1: 1 Repts
2: 7 Loc [Scour_2]

37: Do (P86)

1: 25 Set Flag 5 Low

When flag 5 is low, datalogger will initiate telecommunication.

38: Initiate Telecommunications (P97)

1: 21 Phone Modem/1200 Baud
2: 5 Disabled when User Flag 5 is High
3: 120 Seconds Call Time Limit
4: 150 Seconds Before Fast Retry
5: 2 Fast Retries

Telecommunication command.

6: 5 Minutes Before Slow Retry
7: 16 Failures Loc [Fail_5]
8: 105 Call-back ID

39: Extended Parameters (P63)

The phone number of the laboratory where the office computer was during the experiment is (210) 458-5595. This number should be changed to the number of the TxDOT office computer managing the site.

1: 1 Option
2: 2 Option
3: 1 Option
4: 0 Option
5: 4 Option
6: 5 Option
7: 8 Option
8: 5 Option

40: Extended Parameters (P63)

1: 5 Option
2: 9 Option
3: 5 Option
4: 13 Option
5: 00 Option
6: 00 Option
7: 00 Option
8: 00 Option

41: End (P95)

Check Scour_3 (This is the scour level in Bent #5)

42: If (X<=>F) (P89)

1: 8 X Loc [Scour_3]
2: 3 >=
3: 2 F
4: 30 Then Do

43: Do (P86)

1: 45 Set Port 5 High

44: Excitation with Delay (P22)

1: 3 Ex Channel

2: 0 Delay W/Ex (units = 0.01 sec)

3: 1500 Delay After Ex (units = 0.01 sec)

4: 0000 mV Excitation

45: Do (P86)

1: 10 Set Output Flag High (Flag 0)

46: Set Active Storage Area (P80)

1: 1 Final Storage Area 1

2: 7 Array ID

This instruction stores Scour_3 in Location ID 7. During call back this information will be sent to the office computer.

47: Sample (P70)

1: 1 Reps

2: 8 Loc [Scour_3]

48: Do (P86)

1: 26 Set Flag 6 Low

49: Initiate Telecommunications (P97)

1: 21 Phone Modem/1200 Baud

2: 6 Disabled when User Flag 6 is High

3: 120 Seconds Call Time Limit

4: 150 Seconds Before Fast Retry

5: 2 Fast Retries

6: 5 Minutes Before Slow Retry

7: 17 Failures Loc [Fail_6]

8: 106 Call-back ID

Telecommunication command

50: Extended Parameters (P63)

1: 1 Option

The phone number of the laboratory where the office computer was during

the experiment is (210) 458-5595. This number should be changed to the number of the TxDOT office computer managing the site. Dr. Weissmann's phone number,

2: 2 Option
3: 1 Option
4: 0 Option
5: 4 Option
6: 4 Option
7: 8 Option
8: 5 Option

51: Extended Parameters (P63)

1: 5 Option
2: 9 Option
3: 5 Option
4: 13 Option
5: 00 Option
6: 00 Option
7: 00 Option
8: 00 Option

52: End (P95)

Check Scour_4 (This is the scour level in Bent #6)

53: If (X<=>F) (P89)

1: 9 X Loc [Scour_4]
2: 3 >=
3: 1 F
4: 30 Then Do

54: Do (P86)

1: 45 Set Port 5 High

55: Excitation with Delay (P22)

1: 3 Ex Channel
2: 0 Delay W/Ex (units = 0.01 sec)
3: 1500 Delay After Ex (units = 0.01 sec)
4: 0000 mV Excitation

- 56: Do (P86)**
 - 1: 10 Set Output Flag High (Flag 0)
- 57: Set Active Storage Area (P80)**
 - 1: 1 Final Storage Area 1
 - 2: 8 Array ID

The following instruction stores Scour_4 in Location ID 8. During call back this information will be sent to the office computer.

- 58: Sample (P70)**
 - 1: 1 Reps
 - 2: 9 Loc [Scour_4]

- 59: Do (P86)**
 - 1: 27 Set Flag 7 Low

- 60: Initiate Telecommunications (P97)**
 - 1: 21 Phone Modem/1200 Baud
 - 2: 7 Disabled when User Flag 7 is High
 - 3: 120 Seconds Call Time Limit
 - 4: 150 Seconds Before Fast Retry
 - 5: 2 Fast Retries
 - 6: 5 Minutes Before Slow Retry
 - 7: 18 Failures Loc [Fail_7]
 - 8: 107 Call-back ID

Telecommunication command.

- 61: Extended Parameters (P63)**
 - 1: 1 Option
 - 2: 2 Option
 - 3: 1 Option
 - 4: 0 Option
 - 5: 4 Option
 - 6: 5 Option
 - 7: 8 Option
 - 8: 5 Option

- 62: Extended Parameters (P63)**
 - 1: 5 Option
 - 2: 9 Option
 - 3: 5 Option
 - 4: 13 Option
 - 5: 00 Option
 - 6: 00 Option
 - 7: 00 Option
 - 8: 00 Option

63: End (P95)

SDM-SI04

The following instructions are designed for testing only. THIS IS NOT PART OF THE DATALOGGER CODE OPERATING AT THE MUSTANG CREEK SITE. IF YOU ARE NOT DOING TESTING USING THE SDM-SI04, IGNORE LINES 64 THROUGH 88.

They are used for entering data from a terminal emulator of a computer connected to the datalogger via an SDM-SI04. Output formatter setup for SDM-SI04 is required to transmit a string as shown on the left:

strst 101 "Send Data^J^M"

This output formatter can be stored into SDM-SI04 either by typing the output formatter through command line mode or by entering the output formatter by using P113 command 321 to execute a command line command from the datalogger program.

To use the command line mode, connect a computer serial port to port 1 of the SDM-SI04. The computer should run a terminal emulation program, which is set to 9600 baud, 8 data bits and 1 stop bit. When the computer is connected, the command line can be made active by pressing the small push-button switch next to the status LED in the SDM-SI04 unit. When this happens, the SDM-SI04 prompt (SDM-SI04->) is sent out of port 1. Now you are ready to type your commands in.

Command P113 transmits a string and set up filter ready for returned data. The Last 3 digits of parameter 5 must match the above command line number (Strst 101).

64: SDM-SI04 (P113)

1: 1 Repts
2: 0 Address

3: 2 Send/Receive Port 2

4: 2304 Command

5: 8101 1st Parameters

6: 1999 2nd Parameters

7: 0 Values per Rep

8: 0000 Loc [_____]

9: 1.0 Mult

10: 0.0 Offset

Port 2 on the SDM-SI04 is being used for the communication between the SDM-SI04 and hyper terminal.

This command transmits a string and sets up a filter ready for returned data. The first digit "8" asks SDM-SI04 to transmit a string defined previously (Strst 101). Therefore, "enter data" will be on the computer terminal.

This parameter is used for filter setup. 1 means convert any ASCII numbers to Campbell Scientific floating point. 999 means character not enable.

65: Excitation with Delay (P22)

1: 1 Ex Channel

2: 0 Delay W/Ex (units = 0.01 sec)

3: 800 Delay After Ex (units = 0.01 sec)

4: 0 mV Excitation

Datalogger waits 8 seconds for SDM-SI04 sensor to respond and the data to process.

be transmitted back to the SDM-SI04

66: SDM-SI04 (P113)

1: 1 Reps

2: 0 Address

3: 2 Send/Receive Port 2

4: 4 Command

5: 0 1st Parameters

6: 0 2nd Parameters

7: 2 Values per Rep

8: 10 Loc [Data_1]

9: 1.0 Mult

10: 0.0 Offset

Instruction for reading data back from SDM-SI04 to datalogger

Only 1 SDM-SI04 is connected to datalogger, therefore Reps = 1.

Default SDM-SI04 address is 0.

Port 2 will be used to communicate with computer generating the digital data.

Datalogger uses Command 4 to read the collected data back from SDM-SI04.

There are two values to receive, starting from the input location 10.

Check Data_1

If user input value ≥ 9 , execute the commands within the If statement.

67: If (X \leq =F) (P89)

1: 10 X Loc [Data_1]
2: 3 \geq
3: 9 F
4: 30 Then Do

68: Do (P86)

1: 45 Set Port 5 High

69: Excitation with Delay (P22)

1: 3 Ex Channel
2: 0 Delay W/Ex (units = 0.01 sec)
3: 1500 Delay After Ex (units = 0.01 sec)
4: 0000 mV Excitation

1: 10 Set Output Flag High (Flag 0)

70: Do (P86)

71: Set Active Storage Area (P80)

1: 1 Final Storage Area 1
2: 2 Array ID

72: Sample (P70)

1: 1 Repts
2: 10 Loc [Data_1]

73: Do (P86)

1: 21 Set Flag 1 Low

When flag 1 is low, datalogger will initiate telecommunication.

The three-digit call-back ID on parameter 8 will be sent to the computer

that is receiving the call from the datalogger. After that, the computer will activate the task (Hiplink command) and send a message corresponding with the call-back ID.

- 74: Initiate Telecommunications (P97)**
- 1: 21 Phone Modem/1200 Baud
 - 2: 1 Disabled when User Flag 1 is High
 - 3: 120 Seconds Call Time Limit
 - 4: 150 Seconds Before Fast Retry
 - 5: 2 Fast Retries
 - 6: 5 Minutes Before Slow Retry
 - 7: 12 Failures Loc [Fail_1]
 - 8: 101 Call-back ID

Telecommunication Command

75: Extended Parameters (P63)

The phone number of the laboratory where the office computer was during the experiment is (210) 458-5595.

- 1: 1 Option
- 2: 2 Option
- 3: 1 Option
- 4: 0 Option
- 5: 4 Option
- 6: 5 Option
- 7: 8 Option
- 8: 5 Option

76: Extended Parameters (P63)

- 1: 5 Option
- 2: 9 Option
- 3: 5 Option
- 4: 13 Option
- 5: 00 Option
- 6: 00 Option
- 7: 00 Option
- 8: 00 Option

Must put 13 at the end of phone number to tell datalogger to execute the call back.

77: End (P95)

Check Data_2

78: If (X<=>F) (P89)

1: 11 X Loc [Data_2]
2: 3 >=
3: 8 F
4: 30 Then Do

79: Do (P86)

1: 45 Set Port 5 High

80: Excitation with Delay (P22)

1: 3 Ex Channel
2: 0 Delay W/Ex (units = 0.01 sec)
3: 1500 Delay After Ex (units = 0.01 sec)
4: 0000 mV Excitation

81: Do (P86)

1: 10 Set Output Flag High (Flag 0)

82: Set Active Storage Area (P80)

1: 1 Final Storage Area 1
2: 3 Array ID

83: Sample (P70)

1: 1 Reps
2: 11 Loc [Data_2]

84: Do (P86)

1: 22 Set Flag 2 Low

85: Initiate Telecommunications (P97)

1: 21 Phone Modem/1200 Baud
2: 2 Disabled when User Flag 2 is High
3: 120 Seconds Call Time Limit
4: 150 Seconds Before Fast Retry

- 5: 2 Fast Retries
- 6: 5 Minutes Before Slow Retry
- 7: 13 Failures Loc [Fail_2]
- 8: 102 Call-back ID

86: Extended Parameters (P63)

- 1: 1 Option
- 2: 2 Option
- 3: 1 Option
- 4: 0 Option
- 5: 4 Option
- 6: 5 Option
- 7: 8 Option
- 8: 5 Option

87: Extended Parameters (P63)

- 1: 5 Option
- 2: 9 Option
- 3: 5 Option
- 4: 13 Option
- 5: 00 Option
- 6: 00 Option
- 7: 00 Option
- 8: 00 Option

**88: End (P95)
Final Output**

89: If time is (P92)

- 1: 0 Minutes (Seconds --) into a
- 2: 60 Interval (same units as above)
- 3: 10 Set Output Flag High (Flag 0)

At 0 minutes (from midnight) into a 60-minute interval set the output so that the data from all the sensors will be stored into final storage.

90: Set Active Storage Area (P80)

- 1: 1 Final Storage Area 1
- 2: 1 Array ID

Instruction P80 is defining the storage area and storage location ID for data retrieval by the office computer running PC208.

91: Real Time (P77)

This instruction (P77) is a "Time Stamp."

1: 110 Day, Hour/Minute (midnight = 0000)

It is used so that we have a record of when the data were sampled.

92: Sample (P70)

1: 1 Reps
2: 2 Loc [Bat_Volt]

First, we sample the battery voltage.

93: Sample (P70)

1: 1 Reps
2: 4 Loc [Temp]

Then, temperature.

94: Minimum (P74)

1: 1 Reps
2: 10 Value with Hr-Min
3: 5 Loc [W_Level]

This instruction (P74) will find the minimum water level and the time it occurred within the hour or explaining it another way, the last output and this output.

Only 1 water level, so the reps value is equal to 1.

The time it occurred.

Input location 5 (W_Level)

Similar to P74, P73 finds the maximum values of Scour_1, Scour_2, Scour_3, Scour_4, Data1, and Data2 (Data1 and Data2 are used only for testing).

95: Maximum (P73)

1: 6 Reps
2: 10 Value with Hr-Min
3: 6 Loc [Scour_1]

6 variables will be checked, so Reps = 6.

The operation starts from input location 6 (Scour_1) and ends at input location 12 (Data_2).

96: Sample on Max or Min (P79)

1: 7 Reps
2: 5 Loc [W_Level]

P79 samples the results given by P73 and P74.

97: End (P95)

This instruction tells the datalogger this is the end of the Table 1 Program.

***Table 2 Program**

The Table 2 Program allows you to write another program, which can be unrelated to the Table 1 Program.

02: 0.0000 Execution Interval (seconds)

***Table 3 Subroutines**

The instructions in Table 3 Subroutines can be called by either program from Table 1 or Table 2.

End Program

These are input locations in the datalogger.

-Input Locations-

1 ID 1 0 0
2 Bat_Volt 1 1 1
3 CR10XTemp 1 1 1
4 Temp 1 1 1
5 W_Level 1 5 1
6 Scour_1 1 4 1
7 Scour_2 1 4 0
8 Scour_3 1 4 0
9 Scour_4 1 4 0
10 Data_1 5 6 2
11 Data_2 1 3 0
12 Fail_1 1 0 1
13 Fail_2 1 0 1
14 Fail_3 1 0 1
15 Fail_4 1 0 1
16 Fail_5 1 1 1
17 Fail_6 1 0 1
18 Fail_7 1 0 1
19 _____ 0 0 0

20	_____	0 0 0
21	_____	0 0 0
22	_____	0 0 0
23	_____	0 0 0
24	_____	0 0 0
25	_____	0 0 0
26	_____	0 0 0
27	_____	0 0 0
28	_____	0 0 0

Note:

Before the data are written into the final storage area, they are stored in intermediate memory. Immediately after these data are sampled into permanent final memory, the intermediate data are erased.

APPENDIX F:
**SOFTWARE CODE FOR THE CR10X DATALOGGER FOR MONITORING A
REED SWITCH ASSEMBLY**

APPENDIX F: SOFTWARE CODE FOR THE CR10X DATALOGGER FOR MONITORING A REED SWITCH ASSEMBLY

```

;{CR10X}
;
*Table 1 Program
  01: 15      Execution Interval (seconds)
1:  SDM-SW8A (P102)
  1: 24      Reps
  2: 00      Address
  3: 2       Counts function
  4: 1       Channel
  5: 1       Loc [ RS_1      ]
  6: 1.0     Mult
  7: 0.0     Offset

;-----
2:  If (X<=>F) (P89)
  1: 8       X Loc [ RS_8      ]
  2: 3       >=
  3: 1       F
  4: 30      Then Do

3:  Z=X*F (P37)
  1: 8       X Loc [ RS_8      ]
  2: 0       F
  3: 8       Z Loc [ RS_8      ]

4:  Z=X+F (P34)
  1: 8       X Loc [ RS_8      ]
  2: 8       F
  3: 8       Z Loc [ RS_8      ]

5:  Do (P86)
  1: 10      Set Output Flag High (Flag 0)

6:  Sample (P70)
  1: 1       Reps
  2: 8       Loc [ RS_8      ]

7:  End (P95)

;-----
8:  If (X<=>F) (P89)
  1: 16      X Loc [ RS_16     ]
  2: 3       >=
  3: 1       F
  4: 30      Then Do

9:  Z=X*F (P37)
  1: 16      X Loc [ RS_16     ]

```

```

2: 0      F
3: 16     Z Loc [ RS_16 ]

10: Z=X+F (P34)
1: 16     X Loc [ RS_16 ]
2: 16     F
3: 16     Z Loc [ RS_16 ]

11: Do (P86)
1: 10     Set Output Flag High (Flag 0)

12: Sample (P70)
1: 1      Reps
2: 16     Loc [ RS_16 ]

13: End (P95)

```

```

;-----
14: If (X<=>F) (P89)
1: 24     X Loc [ RS_24 ]
2: 3      >=
3: 1      F
4: 30     Then Do

15: Z=X*F (P37)
1: 24     X Loc [ RS_24 ]
2: 0      F
3: 24     Z Loc [ RS_24 ]

16: Z=X+F (P34)
1: 24     X Loc [ RS_24 ]
2: 24     F
3: 24     Z Loc [ RS_24 ]

17: Do (P86)
1: 10     Set Output Flag High (Flag 0)

18: Sample (P70)
1: 1      Reps
2: 24     Loc [ RS_24 ]

19: End (P95)

```

```

;-----

20: SDM-SW8A (P102)
1: 24     Reps
2: 00     Address
3: 0      Channel state(s) function
4: 1      Channel
5: 25     Loc [ RS_25 ]

```

```

6: 1.0      Mult
7: 0.0      Offset

;-----
21:  If (X<=>F) (P89)
1: 32      X Loc [ RS_32      ]
2: 1       =
3: 0       F
4: 30      Then Do

22:  Z=X+F (P34)
1: 32      X Loc [ RS_32      ]
2: 8       F
3: 32      Z Loc [ RS_32      ]

23:  Do (P86)
1: 10      Set Output Flag High (Flag 0)

24:  Sample (P70)
1: 1       Reps
2: 32      Loc [ RS_32      ]

25:  End (P95)

;-----
26:  If (X<=>F) (P89)
1: 40      X Loc [ RS_40      ]
2: 1       =
3: 0       F
4: 30      Then Do

27:  Z=X+F (P34)
1: 40      X Loc [ RS_40      ]
2: 16      F
3: 40      Z Loc [ RS_40      ]

28:  Do (P86)
1: 10      Set Output Flag High (Flag 0)

29:  Sample (P70)
1: 1       Reps
2: 40      Loc [ RS_40      ]

30:  End (P95)

;-----
31:  If (X<=>F) (P89)
1: 48      X Loc [ RS_48      ]
2: 1       =
3: 0       F
4: 30      Then Do

32:  Z=X+F (P34)
1: 48      X Loc [ RS_48      ]

```

```

2: 24      F
3: 48      Z Loc [ RS_48      ]

33: Do (P86)
1: 10      Set Output Flag High (Flag 0)

34: Sample (P70)
1: 1       Reps
2: 48      Loc [ RS_48      ]

35: End (P95)
*Table 2 Program
  02: 0.0000 Execution Interval (seconds)

*Table 3 Subroutines

End Program

```

-Input Locations-

```

1 RS_1      1 0 1
2 RS_2      1 0 1
3 RS_3      1 0 1
4 RS_4      1 0 1
5 RS_5      1 0 1
6 RS_6      1 0 1
7 RS_7      1 0 1
8 RS_8      1 4 3
9 RS_9      1 0 1
10 RS_10    1 0 1
11 RS_11    1 0 1
12 RS_12    1 0 1
13 RS_13    1 0 1
14 RS_14    1 0 1
15 RS_15    1 0 1
16 RS_16    1 4 3
17 RS_17    1 0 1
18 RS_18    1 0 1
19 RS_19    1 0 1
20 RS_20    1 0 1
21 RS_21    1 0 1
22 RS_22    1 0 1
23 RS_23    1 0 1
24 RS_24    1 4 3
25 RS_25    5 0 1
26 RS_26    9 0 1
27 RS_27    9 0 1
28 RS_28    9 0 1
29 RS_29    9 0 1
30 RS_30    9 0 1
31 RS_31    9 0 1
32 RS_32    9 3 2
33 RS_33    9 0 1
34 RS_34    9 0 1
35 RS_35    9 0 1

```

36 RS_36 9 0 1
37 RS_37 9 0 1
38 RS_38 9 0 1
39 RS_39 9 0 1
40 RS_40 9 3 2
41 RS_41 9 0 1
42 RS_42 9 0 1
43 RS_43 9 0 1
44 RS_44 9 0 1
45 RS_45 9 0 1
46 RS_46 9 0 1
47 RS_47 9 0 1
48 RS_48 17 3 2

-Program Security-

0000

0000

0000

-Mode 4-

-Final Storage Area 2-

0

-CR10X ID-

0

-CR10X Power Up-

3

