

1. Report No. TX-00/7-2915-1	2. Government Accession No.	3. Recipient's Catalog No.	
4. Title and Subtitle TRUCK MONITORING AND WARNING SYSTEMS FOR FREEWAY-TO-FREEWAY CONNECTIONS		5. Report Date October 1999	
7. Author(s) Clyde E. Lee, Darrell W. Borchardt, and Qiyue Fei		6. Performing Organization Code	
		8. Performing Organization Report No. 7-2915-1	
9. Performing Organization Name and Address Center for Transportation Research    Texas Transportation Institute The University of Texas at Austin    The Texas A&M University System 3208 Red River, Suite 200                College Station, TX 77843-3135 Austin, TX 78705-2650		10. Work Unit No. (TRAIS)	
		11. Contract or Grant No. 7-2915	
12. Sponsoring Agency Name and Address Texas Department of Transportation Research and Technology Transfer Section/Construction Division P.O. Box 5080 Austin, TX 78763-5080		13. Type of Report and Period Covered Research Report (9/98 – 8/99)	
		14. Sponsoring Agency Code	
15. Supplementary Notes Project conducted in cooperation with the U.S. Department of Transportation, Federal Highway Administration, and the Texas Department of Transportation. This project was funded as Work Order No. 6 under the Federal Highway Administration's Houston IVHS Priority Corridor Program [Project No. IVH-9348(305)].			
16. Abstract <p>This research focuses on the development and evaluation of a truck monitoring and warning (TM&amp;W) system for detecting high, long, fast trucks at freeway-to-freeway connections and activating displays to warn the truck drivers of potential hazards as their vehicles approach the curved section of an interchange ramp. The basic study was conducted on the elevated left-turn ramp for traffic southbound on I-610 loop freeway to eastbound on SH 225 (LaPorte Freeway) in Houston, Texas.</p> <p>The TM&amp;W system used three infrared light-beam sensors with a special microcontroller-based signal processor, named TDA3 (Traffic Data Acquisition), to determine the speed, length at 7 ft (2.1 m) above the road surface, and arrival time for every vehicle that blocked the light beams. When selected criteria were met, the TDA system sent a warning message to the driver. Software for data collection and processing was developed, and before-and-after speed-change studies were conducted to determine the effect of applying the truck monitoring and warning system at the curved, elevated interchange ramp.</p> <p>The results of this research indicate that activating flashing-yellow-light warning displays for only the trucks exceeding the preset criteria caused an average additional 2 mi/h (3.2 km/h) speed reduction, beyond normal, before the trucks entered the curved portion of the ramp. Recommendations are made for potentially improving the impact of the warning message on drivers.</p>			
17. Key Words Truck warning system, freeway-to-freeway connectors, infrared sensors, interchange ramps		18. Distribution Statement No restrictions. This document is available to the public through the National Technical Information Service, Springfield, Virginia 22161.	
19. Security Classif. (of report) Unclassified	20. Security Classif. (of this page) Unclassified	21. No. of pages 98	22. Price



**TRUCK MONITORING AND WARNING SYSTEMS FOR  
FREEWAY-TO-FREEWAY CONNECTIONS**

*by*

Clyde E. Lee  
Darrell W. Borchardt  
Qiyue Fei

Research Report Number 7-2915-1

Research Project 7-2915  
Truck Monitoring and Warning Systems for Freeway-to-Freeway Connections

Conducted for the

**TEXAS DEPARTMENT OF TRANSPORTATION**

cooperatively by the

**TEXAS TRANSPORTATION INSTITUTE  
TEXAS A&M UNIVERSITY SYSTEM**

and the

**CENTER FOR TRANSPORTATION RESEARCH**  
Bureau of Engineering Research  
**THE UNIVERSITY OF TEXAS AT AUSTIN**

October 1999



## **DISCLAIMERS**

The contents of this report reflect the views of the authors, who are responsible for the facts and the accuracy of the data presented herein. The contents do not necessarily reflect the official views or policies of the Federal Highway Administration or the Texas Department of Transportation (TxDOT). This report does not constitute a standard, specification, or regulation.

There was no invention or discovery conceived or first actually reduced to practice in the course of or under this contract, including any art, method, process, machine, manufacture, design or composition of matter, or any new and useful improvement thereof, or any variety of plant, which is or may be patentable under the patent laws of the United States of America or any foreign country.

**NOT INTENDED FOR CONSTRUCTION,  
BIDDING, OR PERMIT PURPOSES**

### *Research Supervisors*

Darrell W. Borchardt, P.E. (Texas No. 62074)

Clyde E. Lee, P.E. (Texas No. 20512)

### *Researchers*

Wm. R. McCasland, P.E. (Texas No. 21746)

Liren Huang

Robert F. Inman

## **IMPLEMENTATION RECOMMENDATIONS**

The focus of this research was on developing, implementing, and evaluating a system that can (1) monitor traffic continually on a freeway-to-freeway connector ramp, (2) identify all high, long, fast trucks traveling on the ramp, and (3) activate warning devices to help prevent out-of-control accidents by these vehicles. The effectiveness and durability of the infrared light-beam sensor technology and the microcontroller-based data handling processes that were developed and deployed for more than 2 years at the Houston research site were demonstrated. Significant reduction of speed was observed when the system selectively activated supplemental flashing yellow hazard identification beacons above and below standard and experimental warning signs only for those trucks that violated a preset criteria for potentially hazardous operation on the curved ramp.

It is recommended that TxDOT seriously consider implementing the truck detection and warning system on a statewide basis at other candidate freeway-to-freeway connectors. To effect this recommendation, the prototype research-model technology will need to be reduced to commercial practice for manufacture in quantity. Procurement of such a commercial system can probably be accomplished initially through a performance-type specification and a through a request for proposals (RFP). The same commercially available infrared light-beam sensors that were so successfully demonstrated in the project should be specified for incorporation into the production model. The sensor mounting and aiming hardware and the microcontroller-based signal processing technology described in the project report can be referenced as practicable embodiment of the system components in the RFP. Recommendations contained in the project report concerning the implementation of warning displays (signs, hazard identification beacons, Amtech Intellitag) should be considered when the truck detection and warning system is deployed at each selected freeway-to-freeway connector.

## **ACKNOWLEDGMENTS**

This research report represents a joint effort of the Center for Transportation Research at The University of Texas at Austin and the Texas Transportation Institute of the Texas A&M University System. The research was performed for the Texas Department of Transportation in cooperation with the U.S. Department of Transportation and the Federal Highway Administration. The project was funded as Work Order No. 6 under the Federal Highway Administration's Houston IVHS Priority Corridor Program [Project No. IVH-9348(305)]. Dr. Clyde E. Lee of the Center for Transportation Research and Mr. Darrell W. Borchardt of the Texas Transportation Institute served as research supervisors. Mr. Robert L. Wright, Mr. Duane E. Hartmann, and Mr. John M. Gaynor served as project directors and Mr. Thomas D. Newbern served as project coordinator for TxDOT. Special thanks are extended to Mr. William Ische and Mr. Karl Kelsey of the Amtech Transportation Systems Group, Amtech Systems Corporation, for their assistance and cooperation in providing and adapting the Amtech tag-reading software and hardware used for the project. The authors acknowledge the contributions of Musa Misleh and William J. Beichner (TxDOT, Houston District), David Fenno and William R. McCasland (TTI), and Liren Huang, Robert F. Inman, Hussein Tavana, David Crysop, and Kristin Belfield (CTR) for their valuable insights and other contributions throughout this project.

Research performed in cooperation with the Texas Department of Transportation and the U.S. Department of Transportation, Federal Highway Administration.

## TABLE OF CONTENTS

CHAPTER 1. Introduction.....	1
1.1 PROJECT PROBLEM STATEMENT .....	1
1.2 BACKGROUND AND SIGNIFICANCE OF WORK .....	2
1.3 OBJECTIVE OF THE PROJECT .....	5
1.4 IMPLEMENTATION .....	5
1.5 BENEFITS .....	5
CHAPTER 2. The TDA3 System.....	7
2.1 SYSTEM DESCRIPTION AND LAYOUT .....	7
2.2 SYSTEM BLOCK DIAGRAM.....	9
2.3 DATA FORMAT .....	13
2.4 SIGNAL WAVEFORM.....	14
2.5 SIGNAL PROCESSING.....	15
2.6 ACCURACY OF MEASUREMENTS.....	18
2.7 WARNING SIGNS AND HAZARD IDENTIFICATION BEACONS (FLASHERS).....	20
2.8 SYSTEM PARAMETER SETTINGS.....	21
2.9 COMMUNICATION INTERFACE .....	24
2.10 AMTECH SYSTEM .....	24
2.11 THE TEST SITE .....	27
CHAPTER 3. System Evaluation.....	29

3.1 TRAFFIC MONITORING AND DATA ANALYSIS.....	29
3.2 EFFECTIVENESS OF APPLYING THE TDA3 SYSTEM.....	42
CHAPTER 4. Conclusion and Recommendations.....	69
4.1 CONCLUSION .....	69
4.2 RECOMMENDATIONS .....	71
BIBLIOGRAPHY .....	75
APPENDIX. Operation Manual of TDA3 System.....	77



## LIST OF FIGURES

Figure 1.1 Rollover Threshold Values for Various Example Vehicles.....	4
Figure 2.1 TDA3 System Layout .....	7
Figure 2.2 System Block Diagram .....	10
Figure 2.3 Signal Waveforms.....	15
Figure 2.4 Pulse Filter and Length Measurement .....	17
Figure 2.5 Potential Measurement Error at Site.....	19
Figure 2.6 Amtech System .....	25
Figure 2.7 Test Site .....	27
Figure 3.1 Real-Time Display on Monitor Screen .....	29
Figure 3.2 Daily Count of All Vehicles and Violating Trucks in March 1998.....	30
Figure 3.3 Hourly Traffic Volume on Monday .....	31
Figure 3.4 Hourly Traffic Volume on Tuesday.....	32
Figure 3.5 Hourly Traffic Volume on Wednesday.....	32
Figure 3.6 Hourly Traffic Volume on Thursday .....	33
Figure 3.7 Hourly Traffic Volume on Friday.....	33
Figure 3.8 Hourly Violating Trucks on Monday.....	34
Figure 3.9 Hourly Violating Trucks on Tuesday.....	35
Figure 3.10 Hourly Violating Trucks on Wednesday.....	35
Figure 3.11 Hourly Violating Trucks on Thursday .....	36
Figure 3.12 Hourly Violating Trucks on Friday.....	36

Figure 3.13 Speed of Trucks Faster Than 30 mi/h (48 km/h) and $\geq$ 16 ft (4.9 m) at 7 ft (2.1 m) Height on Monday .....	38
Figure 3.14 Speed of Trucks Faster Than 30 mi/h (48 km/h) and $\geq$ 16 ft (4.9 m) at 7 ft (2.1 m) Height on Tuesday .....	39
Figure 3.15 Speed of Trucks Faster Than 30 mi/h (48 km/h) and $\geq$ 16 ft (4.9 m) at 7 ft (2.1 m) Height on Wednesday .....	39
Figure 3.16 Speed of Trucks Faster Than 30 mi/h (48 km/h) and $\geq$ 16 ft (4.9 m) at 7 ft (2.1 m) Height on Thursday .....	40
Figure 3.17 Speed of Trucks Faster Than 30 mi/h (48 km/h) and $\geq$ 16 ft (4.9 m) at 7 ft (2.1 m) Height on Friday.....	40
Figure 3.18 Speed of Trucks Faster Than 30 mi/h (48 km/h) and $\geq$ 16 ft (4.9 m) at 7 ft (2.1 m) Height on Saturday.....	41
Figure 3.19 Speed of Trucks Faster Than 30 mi/h (48 km/h) and $\geq$ 16 ft (4.9 m) at 7 ft (2.1 m) Height on Sunday.....	41
Figure 3.20 Evaluation Test of Speed Change from Site 1 to Site 2.....	43
Figure 3.21 Data Relations of the Speed Change Evaluation .....	44
Figure 3.22 Overlapping Phenomenon on the Two-Lane Ramp.....	46
Figure 3.23 Wheelbase of a Large Truck .....	47
Figure 3.24 Speed Reduction of Violating Trucks from Site 1 to Site 2 (11:00 to 12:00), No Flashers.....	48
Figure 3.25 Speed Reduction of Violating Trucks from Site 1 to Site 2 (12:00 to 13:00), No Flashers.....	49
Figure 3.26 Speed Reduction of Violating Trucks from Site 1 to Site 2 (13:00 to 14:00), No Flashers.....	49
Figure 3.27 Speed Reduction of Violating Trucks from Site 1 to Site 2 (14:00 to 15:00), No Flashers.....	50
Figure 3.28 Speed Reduction of Violating Trucks from Site 1 to Site 2 (15:00 to 16:00), No Flashers.....	50

Figure 3.29 Speed Reduction of Violating Trucks from Site 1 to Site 2 (10:18 to 11:00), Having Flashers.....	52
Figure 3.30 Speed Reduction of Violating Trucks from Site 1 to Site 2 (11:00 to 12:00), Having Flashers.....	52
Figure 3.31 Speed Reduction of Violating Trucks from Site 1 to Site 2 (12:00 to 13:00), Having Flashers.....	53
Figure 3.32 Speed Reduction of Violating Trucks from Site 1 to Site 2 (13:00 to 14:00), Having Flashers.....	53
Figure 3.33 Speed Reduction of Violating Trucks from Site 1 to Site 2 (14:00 to 15:00), Having Flashers.....	54
Figure 3.34 Speed Reduction of Violating Trucks from Site 1 to Site 2 (15:00 to 16:00), Having Flashers.....	54
Figure 3.35 Speed Reduction of Violating Trucks from Site 1 to Site 2 (16:00 to 17:00), Having Flashers.....	55
Figure 3.36 Speed Reduction of Violating Trucks from Site 1 to Site 2 (17:00 to 18:00), Having Flashers.....	55
Figure 3.37 Quantile-Normal Plot of Speed Reduction in Which the Original Speeds Were Between 62 mi/h and 70 mi/h and Warning System Was Not Active (“Before” Case).....	59
Figure 3.38 Quantile-Normal Plot of Speed Reduction in Which the Original Speeds Were Between 62 mi/h and 70 mi/h and Warning System Was Active (“After” Case) .....	60
Figure 3.39 Quantile-Normal Plot of Speed Reduction in Which the Original Speeds Were Less Than 62 mi/h and Warning System Was Not Active (“Before” Case).....	60
Figure 3.40 Quantile-Normal Plot of Speed Reduction in Which the Original Speeds Were Less Than 62 mi/h and Warning System Was Active (“After” Case).....	61
Figure 3.41 Quantile-Normal Plot of Speed Reduction in Which the Headway Was Greater Than 0.1 Minute and Warning System Was Not Active (“Before” Case) .....	64
Figure 3.42 Quantile-Normal Plot of Speed Reduction in Which the Headway Was Greater Than 0.1 Minute and Warning System Was Active (“After” Case).....	65
Figure 3.43 Quantile-Normal Plot of Speed Reduction in Which the Headway Was Less Than or Equal to 0.1 Minute and Warning System Was Not Active (“Before” Case) ...	65

Figure 3.44 Quantile-Normal Plot of Speed Reduction in Which the Headway Was Less Than or Equal to 0.1 Minute and Warning System Was Active (“After” Case) ....	66
Figure A.1 TDA3 Title Form .....	77
Figure A.2 Password Form of TDA3 .....	78
Figure A.3 Choose Connection Mode Form of TDA3.....	79
Figure A.4 Check Form of TDA3 .....	80
Figure A.5 Map Form of TDA3 .....	81
Figure A.6 Monitor Form of TDA3 Before Click Monitor Button.....	82
Figure A.7 Monitor Form of TDA3 After Click Monitor Button .....	82
Figure A.8 Setup Form of TDA3 .....	83

#### LIST OF PHOTOS

Photo 2.1 Thru-Beam IR Sensors.....	10
Photo 2.2 Infrared Receivers Inside Housings .....	11
Photo 2.3 Infrared Sources and Receivers.....	11
Photo 2.4 Inside of the Cabinet .....	12
Photo 2.5 Outside of the Cabinet .....	12
Photo 2.6 Gore of Exit Ramp.....	20
Photo 2.7 Warning Signs and Flashers Before and On the Curve.....	21
Photo 2.8 Warning Signs and Flashers Prior to Curve.....	22
Photo 2.9 View of Ramp from TDA3 Location.....	23
Photo 2.10 Flashers That Are Activated by TDA3 .....	23
Photo 2.11 IT2101 Tag.....	25
Photo 2.12 AA3110 Parapanel Antenna .....	26

## LIST OF TABLES

Table 3.1 Average Daily Traffic Volume (Weekdays) .....	31
Table 3.2 Daily Average Number of Violating Trucks and Peak Hour Volume .....	37
Table 3.3 Ratio of Violating Trucks to Total Trucks (Weekdays).....	38
Table 3.4 Data Matching Between Site 1 and Site 2 in “Before” Study .....	48
Table 3.5 Data matching Between Site 1 and Site 2 in “After” Study.....	51
Table 3.6 Comparison of speed in the Before-and-After Cases by Speed Range .....	58
Table 3.7 Speed Reduction in different Time Headway Groups.....	63
Table 4.1 Ratio of Trucks with Speed More Than or Equal to 60mi/h (96 km/h) to Total Trucks on Weekdays .....	72
Table 4.2 Ratio of Trucks with Speed More Than or Equal to 65mi/h (104 km/h) to Total Trucks on Weekdays .....	73



## **CHAPTER 1. INTRODUCTION**

### **1.1 PROJECT PROBLEM STATEMENT**

Direct connections in freeway-to-freeway interchanges are a major source of traffic congestion and safety concerns. Because the design speed on these connections is usually lower than the design speed on the adjacent mainline roadways, traffic tends to enter the connection curves at higher than desired speed. While such ramps should be posted with regulatory speed limits that reflect the desired travel speeds, the length along the connection ramp is often too short to permit the proper speed reduction distance. Thus, these ramps are provided with advisory signs that describe the safe speeds for the roadway. However, even with proper signs and with additional advisory signs to alert drivers of the critical speed sections, drivers often travel too fast on the ramp. If the vehicle is a large truck with a high center of gravity, the excessive speed can cause the driver to lose control. Additional signs, signals, and markings should be provided to assist the driver in selecting the proper speed.

The Houston District of the Texas Department of Transportation (TxDOT) has already tested various types of sensors to measure speeds and to classify vehicles by size and weight. For this project, some of these technologies, along with some new ones, were applied on the approaches to and within freeway-to-freeway connectors that have sections with low design speeds. The truck monitoring systems were designed to detect large trucks and determine their spot speed. A data processor was used to determine whether the observed conditions were considered to be critical for maintaining vehicle control through the connection. If the spot speed was too high for conditions, warning systems were activated to advise the driver to reduce the vehicle speed. The warning systems were designed to provide dynamic response and high target value and to hopefully achieve compliance to what was, in effect, an advisory speed limit for individual trucks that violated the selected criteria.

The I-610 Loop Freeway in the Priority Corridor Study Area of Houston was selected as a site for application of the truck monitoring and warning system. The difficult factors in the project that require intelligent transportation system (ITS) technologies are the requirements to monitor the vehicles on elevated roadways and to communicate the

information in a very short time as a truck travels over a short distance. Over-the-road sensors are required. Systems that track the vehicle over the short distances could require information that is difficult or perhaps impossible to obtain with conventional methods and equipment. New techniques for displaying messages on roadsides may be enhanced by special means of communicating warnings to the driver within the vehicle.

## **1.2 BACKGROUND AND SIGNIFICANCE OF WORK**

Several literature sources provided insight into the magnitude of problems encountered by large trucks negotiating freeway curves. A survey of knowledgeable organizations was conducted as part of a study evaluating the problem of truck stability (Ref 1). Survey responses from 29 states, four motor carriers, a trailer manufacturer, and the Brotherhood of Teamsters overwhelmingly indicated that rollover was the greatest concern, although yaw instability (often resulting in jackknife) was also regarded as highly problematic. It was discovered that hydroplaning could contribute to truck instability on wet pavements under lightly loaded conditions. In the case of freeway connectors, hydroplaning may become particularly troublesome for unloaded trucks on large-radius curves where combinations of high speeds, poor pavement friction, and/or poor drainage exist (Ref 2, 3). Results of a research study indicated that as many as 21 percent of all truck accidents on urban freeways occur at interchanges (Ref 4). The rollover or jackknife of a truck typically occurs on curved ramps and is often associated with excessive speed and loss of control. Overturned truck crashes on exit ramps at interstate interchanges represent five out of every 100 fatal truck crashes.

The results of another research study demonstrated that there are several factors that cause loss-of-control accidents involving tractor-semi trailers. These are summarized below (Ref 6).

1. **Low roll stability** of the vehicle is the key response characteristic leading to loss of control. Rollover generally results from lateral acceleration forces acting on a vehicle in a steady turn. This is a particular threat to drivers of a heavily-loaded truck, for even in a steady turn, a severe steering maneuver or speeding will cause rollover. Commercial loading practice places the center of gravity high in absolute terms and also high in relation to the width of the tire track; the ratio of the two



dimensions is a measure of the basic roll stability. Figure 1.1 shows rollover threshold values in terms of peak lateral acceleration for the five different tractor-semi-trailer configurations studied. By contrast, the small car does not roll over until the rollover threshold value exceeds 1.2 g's. The lack of stability can cause heavy trucks to roll over in the vicinity of 0.3 g's.

2. Loss-of-control accidents also include **jackknives**. These accidents generally occur at sites where tire/pavement friction is reduced, frequently with unloaded or lightly loaded trailers. Typically, jackknives result from a simple traction deficiency at the drive wheels or light braking, which can cause the drive wheels to lock up. Differing tire/road friction levels on the steering and drive axles can cause a truck to jackknife simply from cornering on a slippery curve.
3. **High-speed off tracking** is another factor leading to loss of control on curves. At low speeds, truck trailers tend to track inboard, but at high speeds, under the influence of lateral acceleration, the rear trailer wheels of articulated truck combinations drift outboard dramatically. This dynamic process is disorienting to the driver. Confused by the opposing responses at different speeds, drivers can lose control. Where curbs line the outside of a curve, moreover, high-speed off tracking can cause tires to hit the curb, producing rollover.
4. **Controlling speed** is another factor in loss-of-control accidents. Drivers must make conscious decisions to keep speed in check on downgrades, especially when negotiating a ramp.

A review of information supplied by the City of Houston Police Department accident division over a 3-month period concluded that approximately one-third of the incidents to which police responded on freeway-to-freeway connectors were attributable to high speed (Ref 5). Incidents involving trucks on interchanges often result in spilled loads and disruption of traffic for several hours. Past incidents on Houston freeways involving large trucks have resulted in the loss of life and extensive damage to the roadway infrastructure. Middleton also tested passive ("truck tipping" warning signs) and active (flashing lights mounted above and below warning signs) warning devices on a freeway-to-freeway connector in Houston (Ref 5).

CASE	CONFIGURATION	WEIGHT (lb) GVW	PAYLOAD CG HEIGHT (in.)	ROLLOVER THRESHOLD (g's)
A. 55 TYP	 <p>Full gross, medium density freight (34 lb/ft<sup>3</sup>)</p>	80,000	83.5	0.34
B.	 <p>“Typical” LTL freight load</p>	73,000	95.0	0.28
C.	 <p>Full gross, full cube homogeneous freight (18.7 lb/ft<sup>3</sup>)</p>	80,000	105.0	0.24
D.	 <p>Full gross gasoline tanker</p>	80,000	88.6	0.32
E.	 <p>Cryogenic tanker (He<sub>2</sub> and H<sub>2</sub>)</p>	100	100	0.26

Figure 1.1 Rollover Threshold Values for Various Example Vehicles (from Ref 6)

### **1.3 OBJECTIVE OF THE PROJECT**

The objective of this project is to implement a system that (1) identifies unsafe speed conditions, which vary by vehicle size, and (2) activates warning devices to prevent out-of-control accidents by at-risk vehicles. The tasks for accomplishing this objective include the following activities:

1. Develop a detailed implementation plan.
2. Prepare plans and specifications and install the TM&W systems (traffic monitoring and warning system), called TDA3 in this report.
3. Prepare software for the data collection, processing, and evaluation of the sensor information.
4. Operate the TDA3 system.
5. Evaluate the TDA3 system
  - to determine the effectiveness of sensor technologies to provide traffic data for truck monitoring;
  - to measure the frequency of unsafe speed occurrences and system response; and
  - to determine the effectiveness of displays and other communication techniques for conveying the warning message to the truck driver.

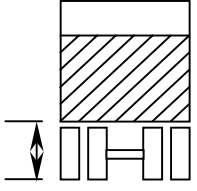
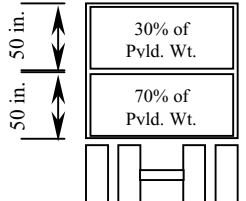
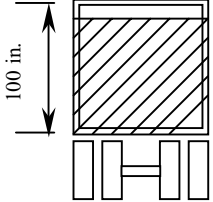
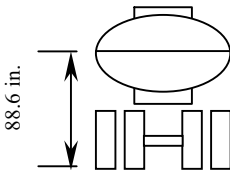
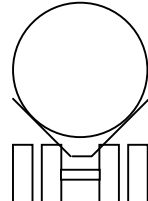
### **1.4 IMPLEMENTATION**

The results of this research indicate the applicability of infrared light-beam sensor technology for providing reliable traffic data for truck monitoring. The effectiveness of displays and other communications techniques for conveying a warning message to truck drivers was evaluated. Recommendations are made concerning implementation of the system at other locations.

### **1.5 BENEFITS**

Expected benefits of the truck monitoring and warning system on freeway connections will be fewer accidents involving trucks and improved freeway safety. A reduction in the number of truck accidents will result in less loss of life and less damage to roadway infrastructure. Additional savings in terms of roadway repairs, reductions in travel

time, travel cost, energy consumption, and emissions will be realized with decreased congestion and fewer detours as a result of fewer truck accidents.

A brief description of the project background and the research objectives have been discussed in this chapter. The TDA3 system structure and test site will be described in the next chapter.

## CHAPTER 2. THE TDA3 SYSTEM

### 2.1 SYSTEM DESCRIPTION AND LAYOUT

The instrument system, called the TDA3 system, that was developed for this project is designed to:

- 1) Detect trucks operating on a freeway-to-freeway interchange exit ramp terminal;
- 2) Compare a truck's speed, height, and length with preset (adjustable) criteria that are considered to be appropriate for safe operation on the curved portion of the ramp; and
- 3) Activate warning devices when the criteria are violated.

This instrument configuration comprises a microcontroller-based traffic data acquisition (TDA3) system with three infrared light-beam sensors, as shown schematically in Figure 2.1.

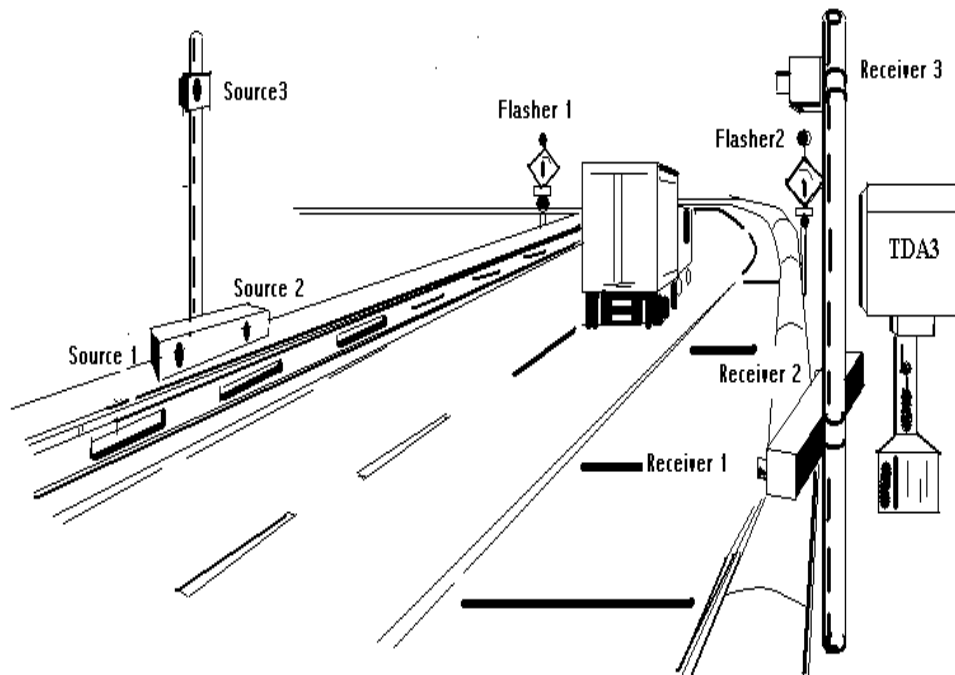

Figure 2.1 TDA3 System Layout

The sensors are commercially available, thru-beam type, modulated infrared light-beam devices that switch a normally ON electric circuit OFF whenever the light beam between the infrared (IR) source and its paired receiver is blocked by an opaque object, such as a vehicle. A TDA3 unit processes the continuous ON-OFF signals from the three sensors with respect to time to count each vehicle that traverses the low-height sensors. The two lower IR light-beam sensors are set exactly 2 ft (0.6 m) apart and mounted 22 in. (0.6 m) above the road surface and are used to record the vehicle arrival time and measure its speed. The third IR sensor is mounted 7 ft (2.1 m) above the road surface. Its blocked-time signal is combined with signals from the two lower sensors to calculate the length of the moving object (truck body or load). The TDA3 system is programmed to provide an output signal that closes an electric switch and keeps it closed for a selected time interval in order to activate a traffic-warning device(s) when any detected vehicle violates the selected criteria.

The system stores the date, arrival time, speed, and measured length of the high part of every violating truck. It also calculates and stores summary statistical data for the hourly vehicle count (all types of vehicles) and the hourly frequency distribution of their measured speeds. A communication feature of the TDA3 allows for monitoring the system status and downloading stored data either via modem and telephone line from a remote location or by connecting a PC microcomputer directly to the RS232C port on the TDA3.

For implementation at the I-610/SH 225 research site, the individual IR source and receiver (detector) units (see Photo 2.1) were each equipped with special aiming hardware and contained inside protective housings (see Photo 2.2). They were mounted on posts just behind the guard fence or bridge rail (see Photo 2.3). A paired source and receiver comprise a sensor unit. The source generates an IR-wavelength light beam, and the receiver detects the beam. An important feature of the IR sensors used for this project (OPCON 70 series) is that the light beam is modulated by a controller unit (see Photo 2.4) at a special frequency. The receiver circuit responds only to the modulated signal from its paired source. Thus, the sensor signal is not adversely affected by other sources of IR light, such as sunlight. It is necessary to have a cable connecting both the source and the receiver of each sensor pair to its common control unit. At the I-610/SH 225 site, the cables from the sensor sources on the

far side of the ramp were buried in conduit, routed across the roadway in an existing pavement joint, and run into a roadside cabinet (see Photo 2.5). All source cables were connected to their respective control unit, along with the matching sensor receiver cables.

The TDA3 circuit board was enclosed in a rugged, weather-resistant housing (4-in. diameter aluminum tube) and placed inside the roadside cabinet (see Photo 2.4) along with a modem. The cabinet was supplied with 110 VAC electric power and two data-quality telephone lines. A buried cable took the TDA3's output switch-closure signal downstream beside the edge of the ramp some 800 ft (250 m) to a traffic signal controller cabinet where it was used to activate the load switches of the yellow flashing signal heads. The flashing signal heads were mounted on the bridge in advance and on the curved section of the elevated ramp. Similarly, another cable took this signal to a cabinet some 200 ft (60 m) downstream where it was used to switch the transmitting antenna of an Amtech Intellitag microwave communication system. These warning displays are described in greater detail in following sections.

## **2.2 SYSTEM BLOCK DIAGRAM**

Figure 2.2 shows a block diagram of the functional components of the TDA3 system. In this figure, S1, S2, and S3 are the IR source devices; R1, R2, and R3 are the IR receivers; and C1, C2, and C3 are the sensor control units. Three sets of OPCON 70 series thru-beam infrared sensor units are used to implement three infrared frequency light beams. Each unit has one infrared source (S), one receiver (R), and one control unit (C). Whenever an object on a vehicle blocks one of the infrared beams, it will generate a pulse on the corresponding output terminal of the control unit. The three outputs from C1, C2, and C3 are each sent to a separate channel of the TDA3 traffic data acquisition board. The TDA3 design is based on a Motorola MC68HC11E9 microcontroller and includes other circuitry used to process the sensed signals, store data, and control warning devices. The TDA3 has 32K x 8-bit memory that can be used to record information for 4,094 individual vehicles that are higher than 7 ft (2.1m), longer than 16 ft (4.9 m), and faster than a preset speed. A laptop PC microcomputer is used to start the system or download data through the RS232C port directly; a modem can

also be connected to the RS232C port to access the TDA3 via telephone line from a remote location.

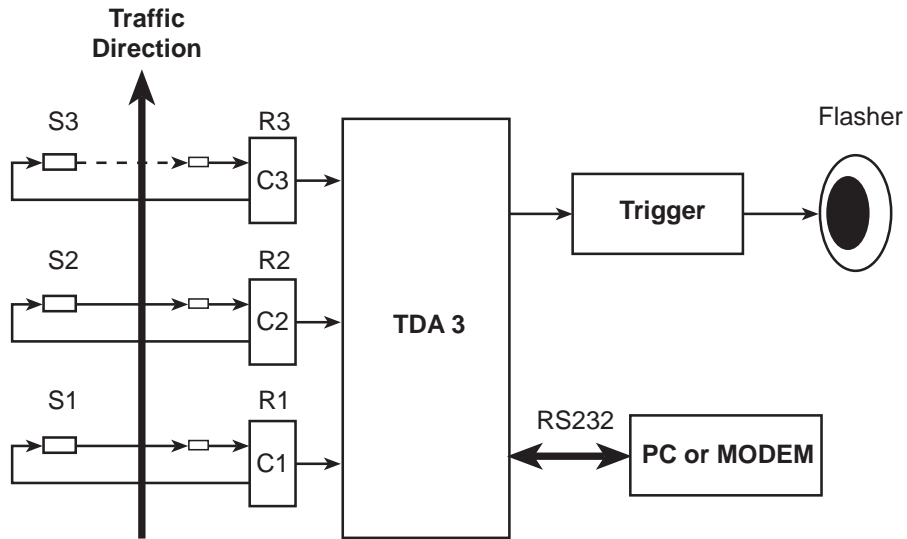

Figure 2.2 System Block Diagram

**VERY-LONG-RANGE THRU-BEAM**

Precise alignment must be maintained for this model. 6142A or 6168A mounting brackets are recommended.

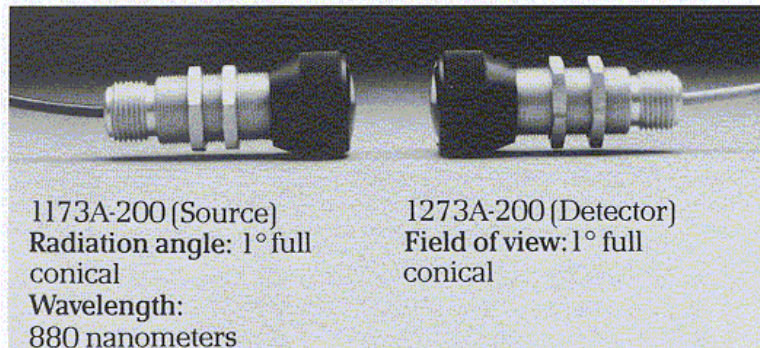

Photo 2.1 Thru-Beam IR Sensors



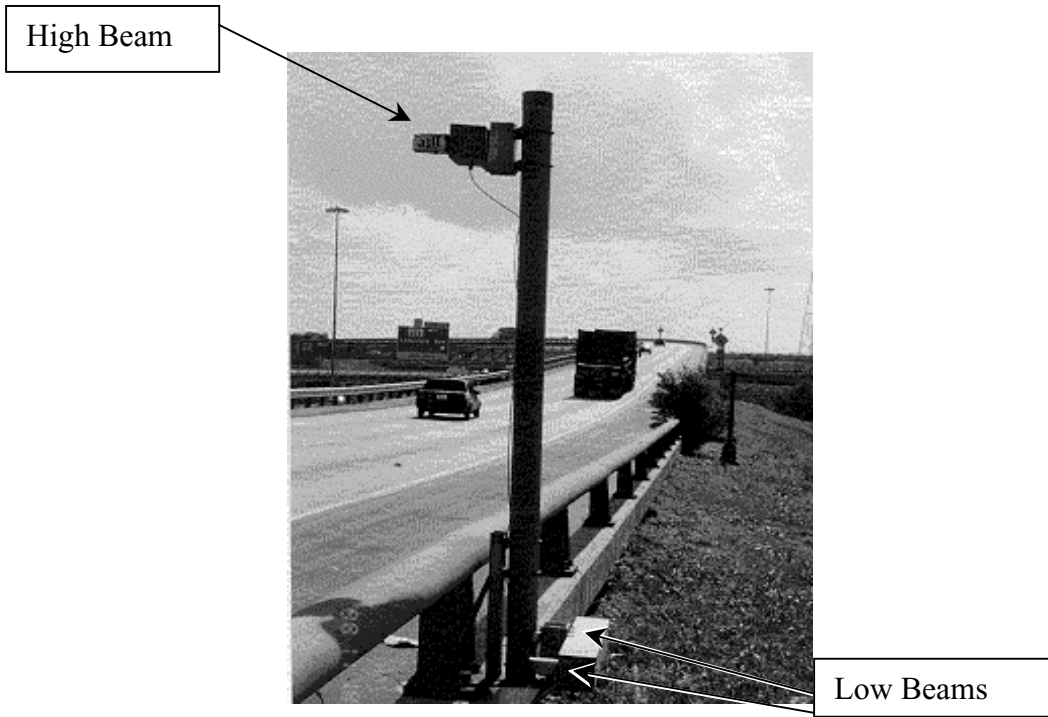

Photo 2.2 Infrared Receivers Inside Housings

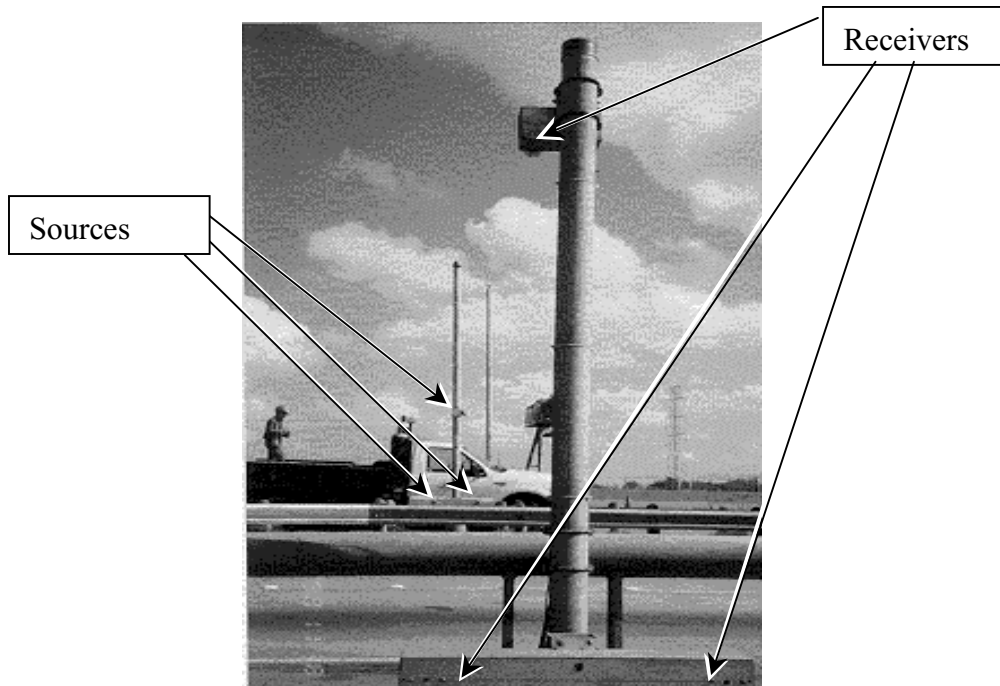

Photo 2.3 Infrared Sources and Receivers

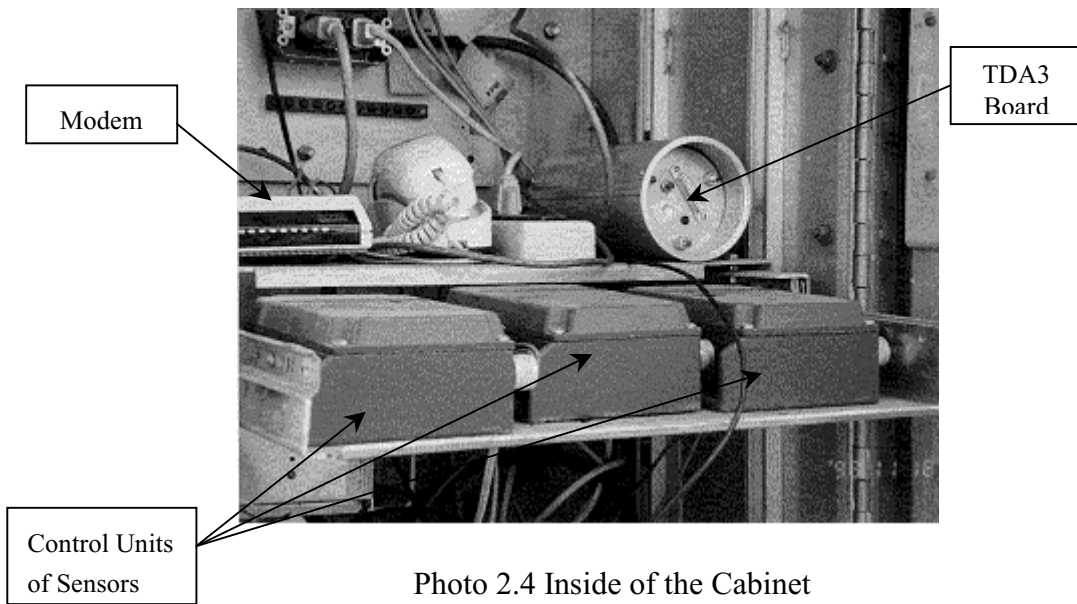

Photo 2.4 Inside of the Cabinet



Photo 2.5 Outside of the Cabinet

## 2.3 DATA FORMAT

Stored traffic data that can be downloaded into a file include the following:

- Header
- Summary traffic data
- Individual vehicle data
- End information

All data are in text format. The header information includes file name, start date, start time, threshold speed, filter delay, flasher time, and site number. The filename is designated T001 followed by current month, day, and year. The threshold speed is a selected speed value chosen by the user to be the safety criterion for triggering warning devices. Filter delay is also an input parameter for the infrared pulse time filter, which is usually set between 0.2 and 0.5 s; for this project, 0.4 s was used. Flasher time is the control parameter for the flasher to remain ON to warn an approaching truck driver. It can be set from 0 to 255 s depending on the travel time of the violating truck from its detection point to its passing the display; at the project site, 12 s was used. The site number code can be set between 0 and 255. For each violating truck, the times at end of truck, speed, and high-part length are each recorded. After downloading all the stored data, the end date and time are added to the data file automatically. These data are arranged in the file in the following format:

*Header*

**Filename: T001mmdd.yy**

**Start Date: mm-dd-yy**

**Start Time: hh:mm:ss**

**Threshold Speed: xx mph**

**Filter Delay: 0.xx s.**

**Flasher Time: xx s.**

**Site number: x.**

---

*Summary Traffic Data*

**Hourly count:**

XXX XXX XXX XXX XXX XXX XXX XXX XXX XXX XXX XXX XXX

**Speed Distribution:** (*By Speed Range, see Figure 3.1*)

XXX XXX XXX XXX XXX XXX XXX XXX XXX XXX

---

*Individual Vehicle Data*

*Time      Speed   Length*  
**hh:mm:ss    xxx    xxx** (*one line for each vehicle*)

---

*End Information*

**End Date:** mm-dd-yyyy

**End Time:** hh:mm:ss

All the stored data can be assigned to a user-defined file and downloaded through the RS232C port to a PC computer. During long-term running, if the memory overflows before downloading, the system will lock, and data will be lost. The reset button must be pushed on-site manually to restart the system.

## 2.4 SIGNAL WAVEFORM

An advantage of the infrared light-beam sensor is the ON or OFF characteristic of its digitized output signal. For each blocking of the beam, a time-related pulse is generated at the output terminal of the control unit. In the TDA application, the pulse indicated that some part of a vehicle passed through the beam and interrupted it. The duration of the sensed pulse depends on the length and speed of the vehicle. Under constant speed, the longer the vehicle, the longer the duration of the pulse will be. According to the time relationships among the pulses from three sensors, the speed and length of the parts of the vehicle that were sensed can be calculated. Figure 2.3 is a drawing that shows typical signal waveforms from the three IR sensors.

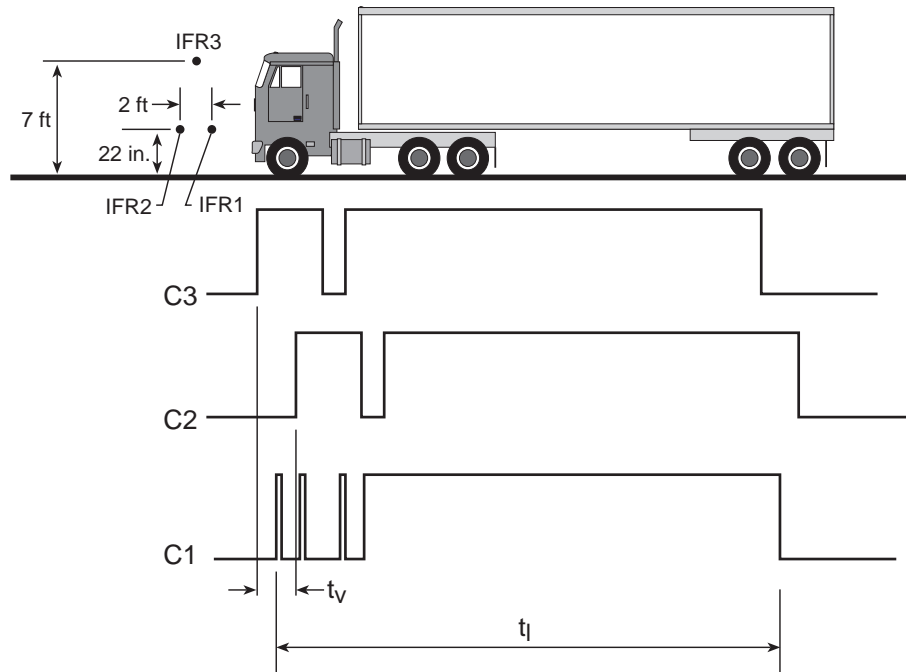

Figure 2.3 Signal Waveforms

## 2.5 SIGNAL PROCESSING

Software embedded in the TDA3 processes the IR sensor output signals to determine the speed and length characteristics of each observed truck that might indicate impending danger in negotiating the ramp ahead at the measured speed. The critical length value that has been chosen to indicate potential overturning propensity or a handling problem is that length measured from the front edge of the first object to the rear edge of the last object on the same vehicle at a height of 7 ft (2.1 m) above the road surface. This height is the mounting height of the high infrared light-beam sensor, IFR3, shown in Figure 2.3. The critical length value chosen for the study was 16 ft (4.9 m) — a length that does not include most truck tractors running without a trailer or pulling a semitrailer likely to have a low center of mass. It does, however, include most tankers, box-body single-unit trucks, and semi-trailers (empty or loaded), and all standard cargo containers, because these are either 20 ft (6 m) or 40 ft (12 m) long.

### 2.5.1 Speed

The speed measurement is based on the distance between the two low-height light-beam sensors, IFR1 and IFR2, and the time difference,  $t_v$ , between the front edge of the signal pulses from control units C1 and C2, as shown in Fig 2.3. Speed is calculated as

$$v = \frac{d}{t_v} \quad (\text{Eq 2.1})$$

Where:  $v$  is speed in ft/s,

$d$  is distance between IFR1 and IFR2, ft, and

$t_v$  is time between front edges of pulses from C1 and C2, s.

### 2.5.2 Length

To measure the vehicle length value of interest, as discussed above, it was necessary to use a digital filter to process the signal from C3. To understand this need, refer to Figure 2.4. In this figure, a typical sequence of pulses from control unit C3 for two successive trucks is shown. When the first object on the truck blocks IFR3's beam, the output of control unit C3 changes from low to high. At this time, a timer is triggered to record the elapsed time. When the first object goes out of the beam and the pulse consequently goes from high to low, the timer value is read into a digital "length" register, and simultaneously a window (filter) timer is started with a  $t_w$ -s limit. The value of  $t_w$ , which can be set by the user, effectively defines the minimum time gap between successive high objects that will indicate two separate vehicles, rather than two high objects on the same vehicle. During the  $t_w$  period, if the IFR3 beam is blocked again, the signal goes high, and the system resets the window timer and continues to look at the C3 status. Sequentially, when the output signal of C3 goes low again (beam unblocked), the system reads the current timer value into the digital "length" register (replacing the previous value) and simultaneously resets the window (filter) timer. This process will continue until the window (filter) timer reaches its limit time,  $t_w$ , without IFR3's beam being blocked again to generate a high pulse signal on C3. At this time, the value,  $t_l$ , stored in the digital "length" register represents the time when the rear edge of the last high object on the truck passed out of the sensor beam, and it can be used to

calculate the overall length,  $L$ , of high objects on the truck being measured. In terms of  $t_l$  and  $v$  (see Eq 2.1), overall length,  $L$ , can be calculated as

$$L = t_l \times v \quad (\text{Eq 2.2})$$

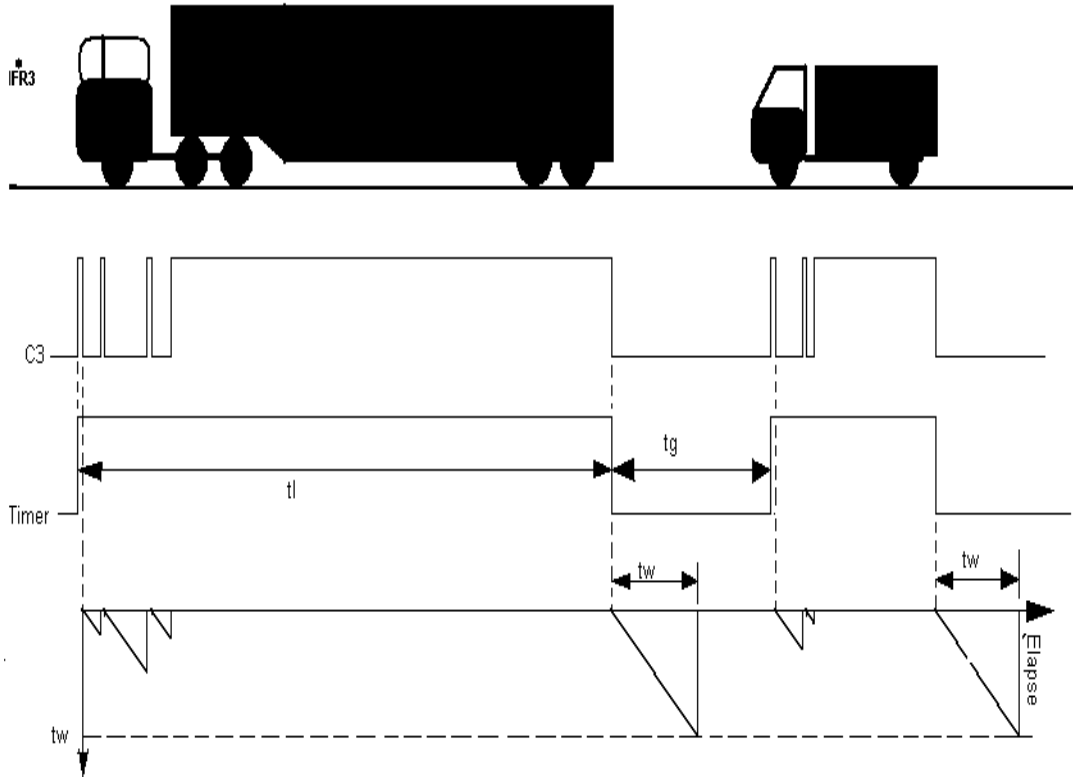

Figure 2.4 Pulse Filter and Length Measurement

### 2.5.3 Comparison with Warning Criteria

The TDA3 has been programmed to compare the calculated speed and length values that result from processing the sensor signals for each individual truck with the user-selected criteria values set into the TDA3 and to produce an output trigger signal (switch contact

closure) if the criteria are violated. This output signal can be used to activate warning displays visible to the truck's driver as the vehicle approaches the potentially hazardous, curved section of the ramp ahead at what is considered to be an excessive speed.

## 2.6 ACCURACY OF MEASUREMENTS

The measurement accuracy of speed and length is dependent on the effective beam diameter of the infrared sensors and the output response time of the control units. The effective diameter of the beam at the receiver lens was found to be approximately 0.5 in. (13 mm). Because the very small (1 mm<sup>2</sup>) photo-diode is centered in the lens, the maximum effective radius of the conical beam is 0.25 in. (6.4 mm); otherwise, the photo-diode cannot get sufficient light (see Figure 2.5).

The critical radius of the conical beam at the location where a truck will block it before arriving at the center of the beam is called measurement error,  $e$ , and is calculated as

$$e = \frac{0.25 \times 17.7}{38} = 0.116 \text{ in.} = 3 \text{ mm} \quad (\text{Eq 2.3})$$

Because the system uses two thru-beam sensors to measure speed, the total measurement error is  $2 * e = 0.23$  in. (6 mm). The distance between the centers of the two beams is carefully controlled during construction and is 24 in. (0.6 m), so the potential error percentage is  $0.23/24 = 0.96$  percent. Assuming the maximum speed of a truck is 75 mi/h (121 km/h), the measurement error is 0.72 mi/h (0.12 km/h), less than 1 mi/h (1.6 km/h).



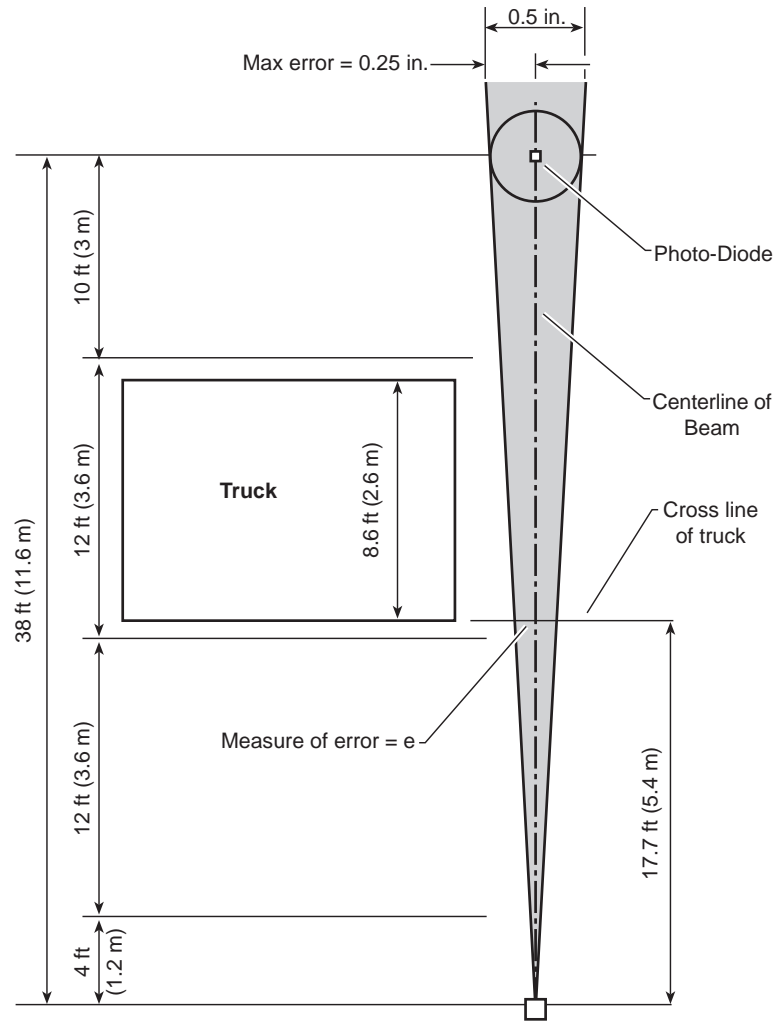

Figure 2.5 Potential Measurement Error at Site

The control unit of the thru-beam sensors has response times: dark-to-light = 1.5 ms and light-to-dark = 3 ms. Because the two control units used for speed measurement have the same response time, there is no systematic effect on this measurement. However, given that only one high beam was used to measure length, the response time can cause a time measurement error comprising 1.5 ms plus 3.0 ms, or 0.0045 s. Still assuming the speed is 75 mi/h (110 ft/s), then

$$\Delta L = V \times \Delta t = 110 \times 0.0045 = 0.5 \text{ ft} \quad (\text{Eq 2.4})$$

The accuracy of length measurements is within 0.5 ft (0.15 m).

## 2.7 WARNING SIGNS AND HAZARD IDENTIFICATION BEACONS (FLASHERS)

Warning signs are used when it is deemed necessary to warn traffic of an existing or potentially hazardous condition. They may sometimes be supplemented by a Hazard Identification Beacon — a flashing circular yellow signal indication — called herein a flasher (Ref 12). At the study site, the first such sign is an advisory exit speed sign, EXIT 35 mph, with an 8 in. (0.2 m) flasher on top, located at the exit ramp gore (see Photo 2.6). This flasher operates continually and apparently has little effect on the speed of exiting vehicles. The second warning display consists of two 8 in. flashers (one above and one below the warning sign), a truck overturn sign, and a 35 mph advisory speed plate; it is located 550 ft (168 m) from the beginning of the exit ramp terminal (see Photo 2.8). The third warning sign group includes a curve sign with a 35 mph advisory speed plate below and an 8 in. flasher above the warning sign (see foreground in Photo 2.7). This array is 1,056 ft (320 m) from the beginning of the ramp and 64 ft (19 m) in advance of the first horizontal curve. The fourth sign array is the same as the second. It is located 1,256 ft (380 m) from the beginning of the ramp on the horizontal curve. All sign assemblies are post-mounted on the right-hand side of the ramp (see Photos 2.9 and 2.10).



Photo 2.6 Gore of Exit Ramp



Photo 2.7 Warning Signs and Flashers Before and On the Curve

## 2.8 SYSTEM PARAMETER SETTINGS

System parameters used to implement the criteria for a violating truck include its speed and length (at a selected height). Other parameters that must be set according to the site road geometry and traffic are filter time and flashing time.

1. Speed criterion

The speed criterion was set to 56 mi/h (90 km/h). This value will be discussed in Chapter 4.

2. Truck length at a selected height

The IFR sensors were set at a height of 7 ft (2.1 m) above the road surface to avoid detection of vans and pick-up trucks. These vehicles were not considered to have a high risk of overturning. All standard production vans sold in America in 1985 were 6'10" in height or lower (Ref 13). An object length of 16 ft (4.9 m) was used to focus the warning displays on trucks with high loads or bodies of sufficient length to suggest a high center of gravity.

3. Filter time

The filter time was set at 0.4 s. During the filter time, a truck traveling at a speed of 56mi/h = 82 ft/s (90 km/h) will move a distance of  $82 * 0.4 = 32.8$  ft (10 m). Normally, the gap between two objects comprising one vehicle will not be more than 32.8 ft (10 m). So, the filter time of 0.4 s can assure that a vehicle exceeding the

speed criterion and loaded with two objects separated by an increment less than this distance will not be recorded as two vehicles.

4. Flashing time

According to on-site observations, the average travel time from the TDA3 to the beginning of the ramp curve for violating trucks was about 12 s. The flashing time was, therefore, set to 12 s so that the flashers would stop operation after the approaching truck entered the curve.

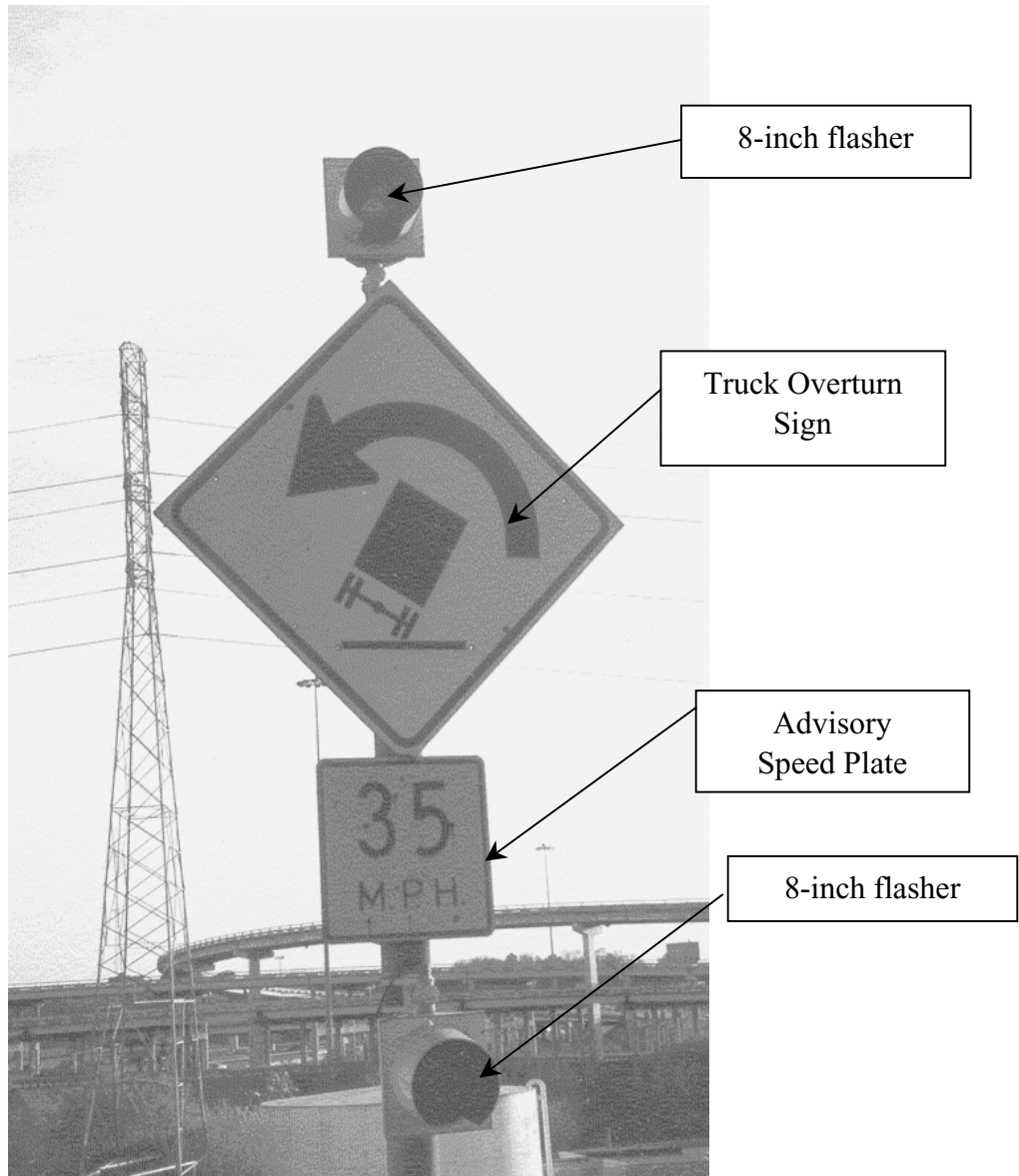

Photo 2.8 Warning Signs and Flashers Prior to Curve



Photo 2.9 View of Ramp from TDA3 Location



Photo 2.10 Flashers That Are Activated by TDA3

## **2.9 COMMUNICATION INTERFACE**

In the TDA3 system, the communication interface between the signal processor software and external devices is implemented in software and passed through the RS232C communications port of the Motorola MC68HC11 E9 microcontroller. Both signal processing and communication software are retained in the electrically erasable programmable read-only memory (EEPROM) of the microcontroller. An IBM or compatible microcomputer has been programmed to communicate with the TDA3 system signal processor unit through its RS232C communication port for gathering and storing traffic data. The data are displayed in real time on the screen of the microcomputer. Control signals can also be sent via the RS232C communications port and modems to traffic warning devices on-site or at remote locations. The programs stored on the microcontroller EEPROM are changeable from a remote location through the communication link.

## **2.10 AMTECH SYSTEM**

A basic Amtech Intelligent-Tag-On-Vehicle system (Ref 15) consists of tags, antennas, and readers. The reader's radio frequency source is either integrated or a separate component. The reader broadcasts radio frequency energy over an adjustable area called the read zone or reader footprint. The tag on the vehicle reflects a small part of this radio frequency energy back to the antenna and can also send a sound and flashing visual message to the driver. The reflected radio waves incorporate the tag's unique identification code and other stored data. The antenna relays the signal to the reader, which can add such information as date/time to the tag's identification code, and stores it in a buffer. The reader can transmit the tag's identification code to the customer's information management system; the entire process takes only milliseconds. Figure 2.6 shows the system components.

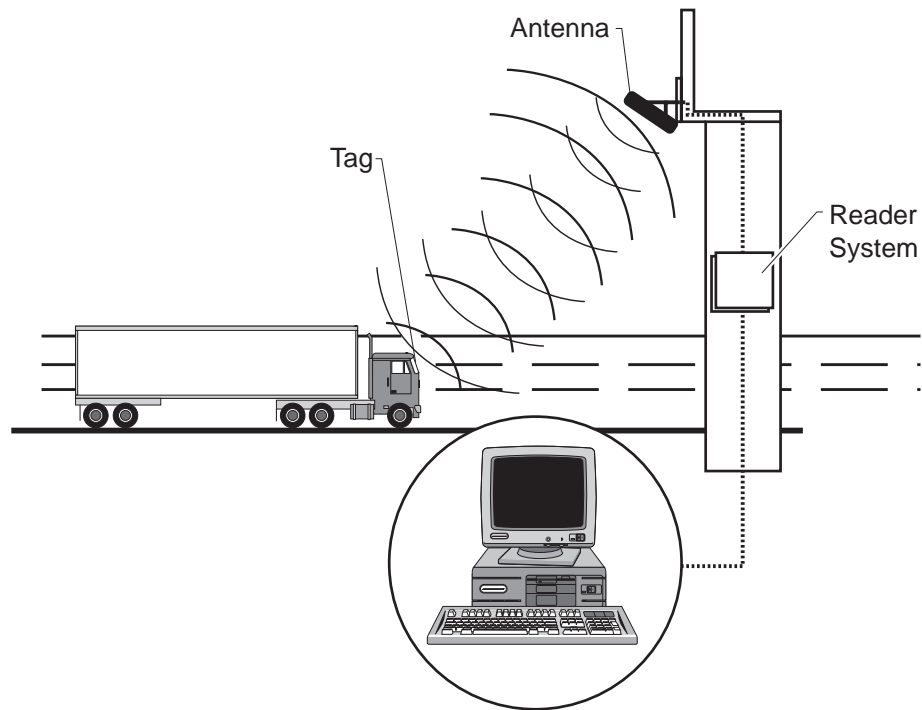

Figure 2.6 Amtech System

- Tag

The IT2101 Intellitag is an RF-programmable, battery-powered radio device designed for high-speed two-way communications (see Photo 2.11).



Photo 2.11 IT2101 Tag

- Antenna

Photo 2.12 shows an antenna mounted on a post. This research used two AA3110 Parapanel antennas arranged together.



The AA3110 Parapanel antenna is a precision dipole array designed for directional transmission and reception of radio frequency (RF) signals in the 902- to 928-MHz RF band.

Photo 2.12 AA3110 Parapanel Antenna

- Reader

The microprocessor-controlled IT 2001 reader conducts two-way RF communication with the Intellitag 2000 series tags using an open communications protocol based on Title 21 of the California State Code of Regulations, AVI Compatibility Specification.

The system includes an RF transceiver, logic control unit, fault-tolerant memory, RS-232 communications port, RS-485 reader synchronization port, low noise power supply, and a rugged enclosure.

The IT 2001 reader transmits an RF polling signal to IT 2100 series tags that respond by encoding the signal and reflecting it back to the reader using a reliable and proven modulated backscatter technique. The reader, on receiving the modulated signal from the tag,



decodes the ID information, confirms message integrity, and transmits the code to the host computer system. When writing information to the tag, the reader formats data into a modified Manchester coded signal sequence for transmission to the tag.

In this research study, the Amtech system antenna was not always turned on. When the TDA3 detected a violating truck, it sent a signal to trigger a radio-frequency (RF) switching relay to activate the antenna on the Amtech system at the same time as the flashers on the warning signs were turned on. Consequently, the driver of an Intellitag-equipped truck received two warning signals: flashers on the roadside and a tag warning light and sound inside the truck.

The Amtech system was first installed at the project site on June 29, 1998, and fifty tags were subsequently distributed to five truck companies. From 12:00 to 17:00 on February 17, 1999, and again on February 24, 1999, speed-change data were collected while using the Amtech system and manual observation. Only six violating trucks were recorded. The sample size is much too small to provide useful statistical data.

## 2.11 THE TEST SITE

The test site was on the ramp that connects I-610 and SH 225 in the southeast area of Houston (see Figure 2.7).

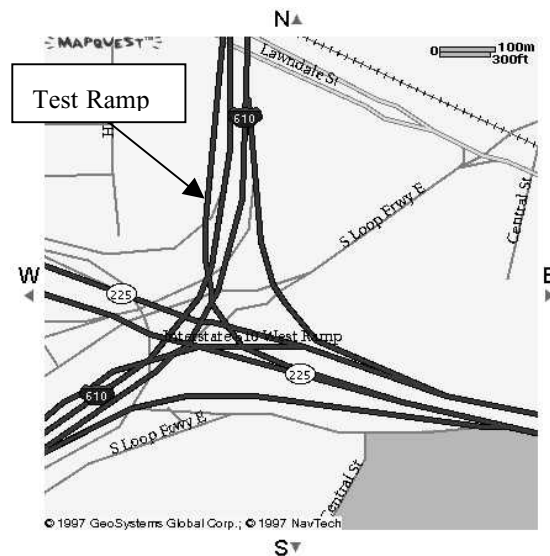

Figure 2.7 Test Site



## CHAPTER 3. SYSTEM EVALUATION

The main objective of the system evaluation was to determine the effectiveness of the TDA3 system in providing traffic data for truck monitoring and to measure the effectiveness of applying the TDA3 system in effecting a speed reduction by trucks thought to be in potential danger on the curved interchange ramp.

### 3.1 TRAFFIC MONITORING AND DATA ANALYSIS

#### 3.1.1 Effectiveness of TDA3 System for Truck Monitoring

From January 1998 through May 1999, the TDA3 system continually collected traffic data on the ramp connecting I-610 and SH 225 in the southeast area of Houston. These data included:

- hourly traffic volume for all vehicles,
- daily speed distribution for all vehicles, and
- arrival time, speed, and length of every violating truck.

The real-time display on the computer's monitor screen of the above information is shown in Figure 3.1.

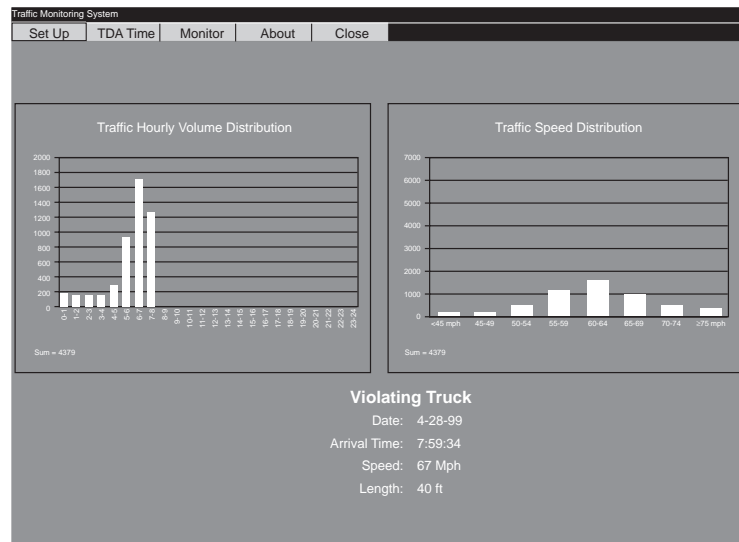

Figure 3.1 Real-Time Display on Monitor Screen

All real-time data were saved into the daily files (text format) and downloaded to a remote server. It should be noted that the TDA3's infrared light beams extend across both lanes on the two-lane ramp; therefore, two vehicles running side-by-side will interrupt the counting beam simultaneously and register as only one vehicle. The volume count value will be somewhat lower than actual owing to this phenomenon. Figure 3.2 depicts a plot of daily traffic volume data collected by the system continuously for 1 month.

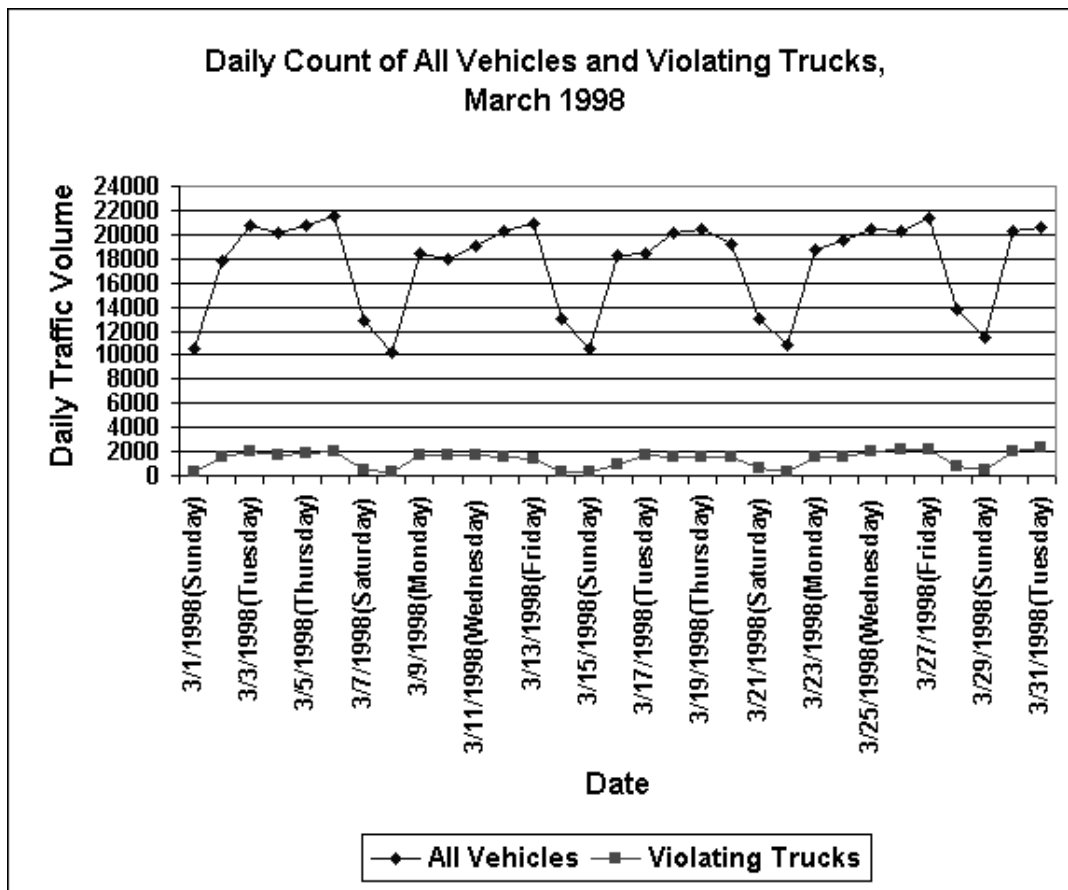

Figure 3.2 Daily Count of All Vehicles and Violating Trucks in March 1998

The continuity and stability of the TDA3 system is evident from the data shown in Figure 3.2. The TDA3 system can effectively provide traffic data for truck monitoring. The traffic data analysis will be described in the following sections.

### 3.1.2 Traffic Volume

The average daily traffic volume on weekdays during the period January 1998 through May 1999 is summarized in Table 3.1. The data in Table 3.1 show that the daily traffic volume was slightly lower on Monday. The hourly traffic volumes from Monday to Friday are plotted in Figures 3.3 to 3.7. The data show that the hourly traffic volume was very stable on Tuesdays and Wednesdays, and that the time periods from 6:00 to 7:00 and 17:00 to 18:00 were peak hours.

Table 3.1 Average Daily Traffic Volume (Weekdays)

Day	Average Daily Traffic Volume
Monday	19,444
Tuesday	20,271
Wednesday	20,469
Thursday	20,522
Friday	20,803

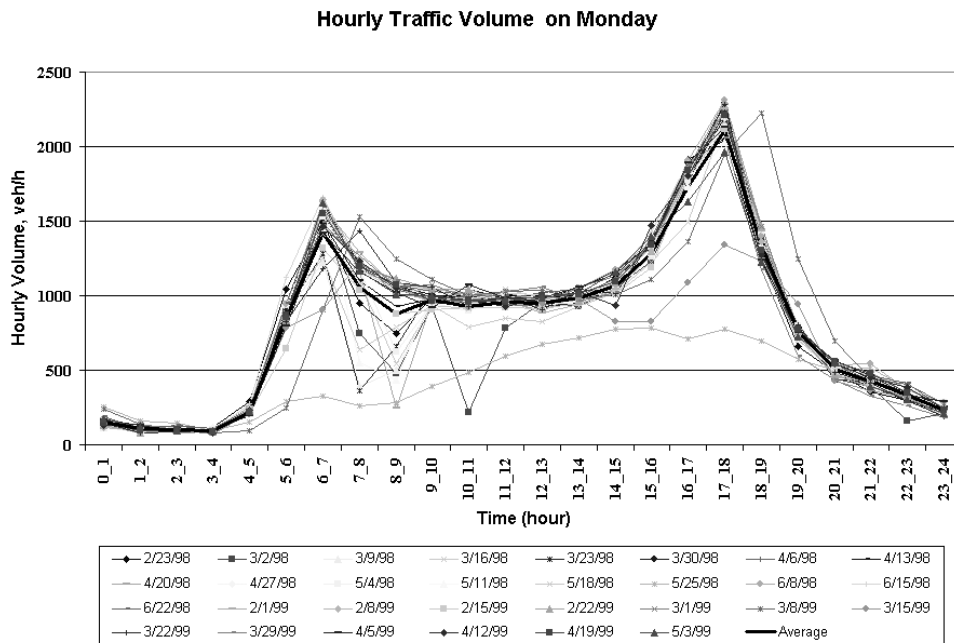

Figure 3.3 Hourly Traffic Volume on Monday

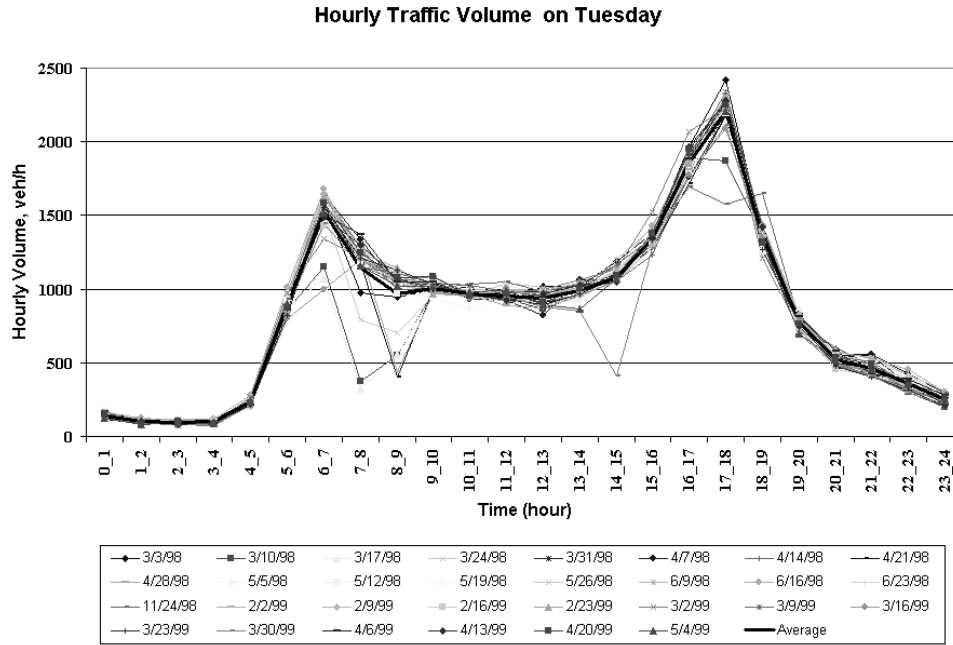

Figure 3.4 Hourly Traffic Volume on Tuesday

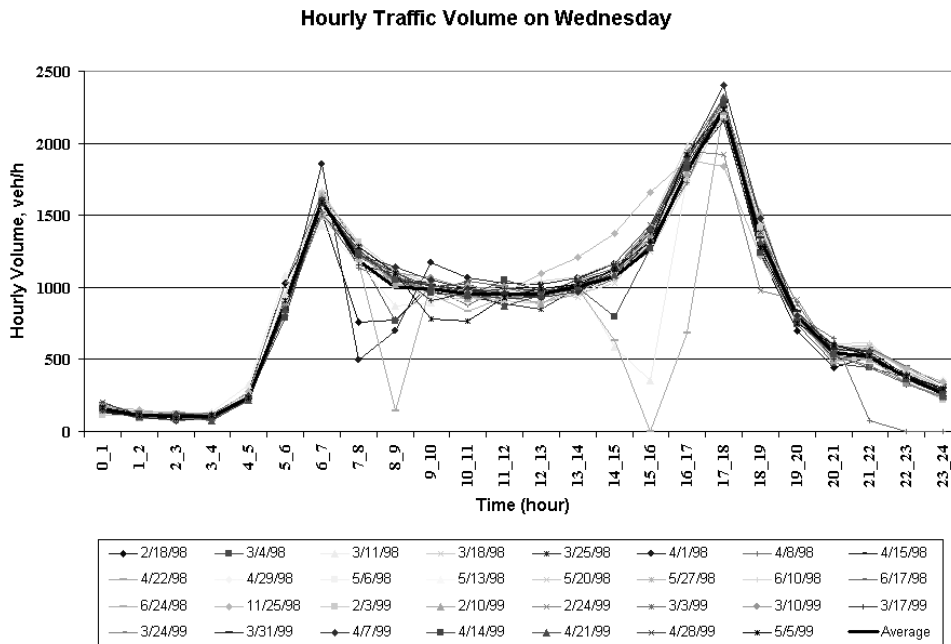

Figure 3.5 Hourly Traffic Volume on Wednesday

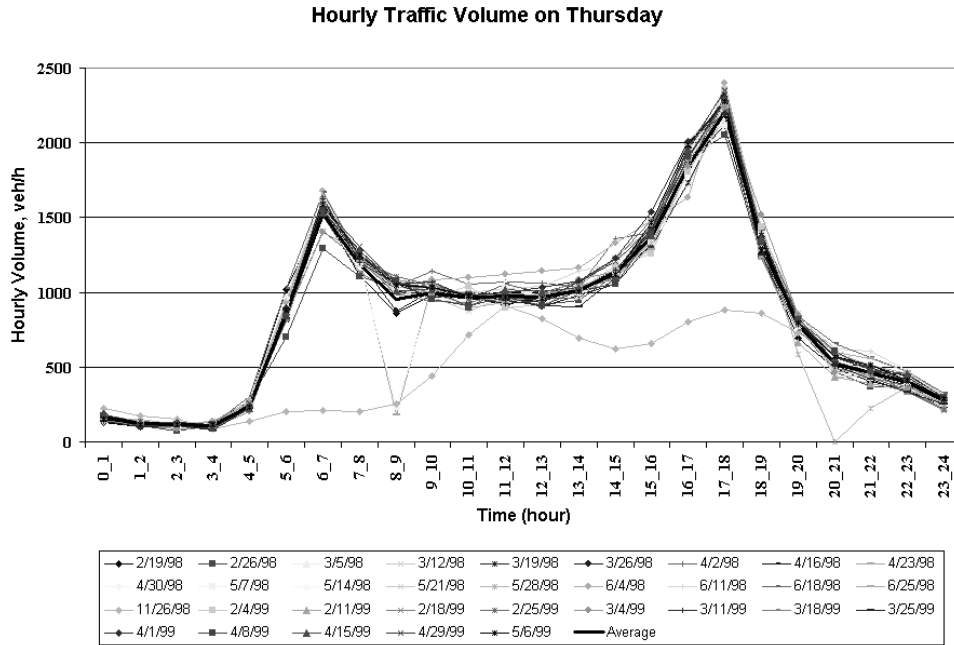

Figure 3.6 Hourly Traffic Volume on Thursday

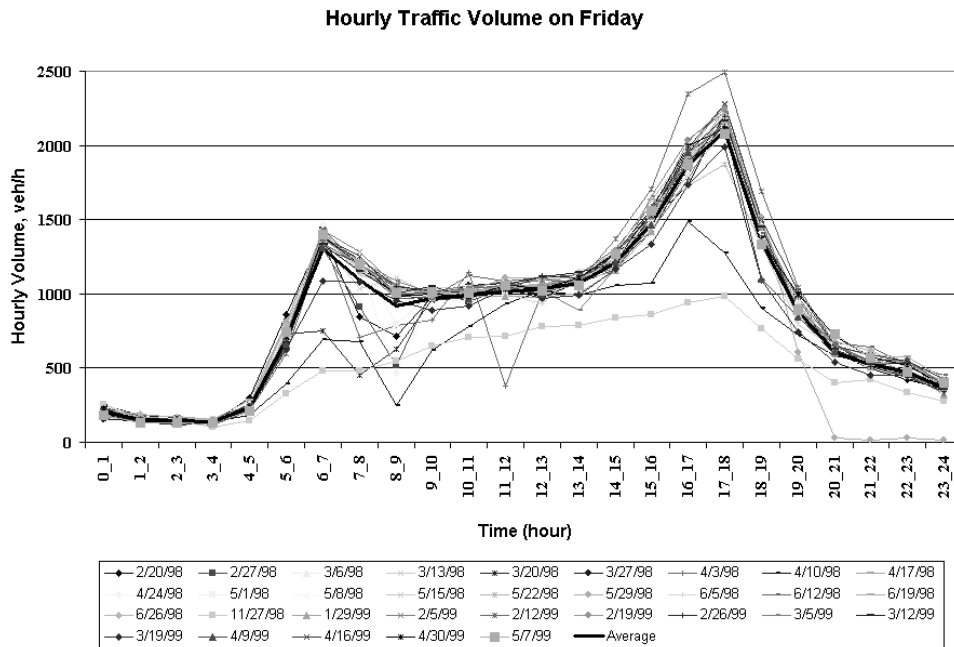

Figure 3.7 Hourly Traffic Volume on Friday

### 3.1.3 Violating Trucks

Any truck that is longer than 16 ft (4.9 m) at a height of 7 ft (2.1 m) and traveling faster than the preset speed of 56 mi/h (90 km/h) is designated as a violating truck. The number of violating trucks each hour from Monday to Friday is plotted in Figures 3.8 to 3.12. There is some variation in the counts on Tuesdays and Wednesdays, and the number of violating trucks is usually greater from 9:00 to 17:00. Interestingly, there is a reversal of the pattern, in which the number of violating trucks is greater in off-peak hours than in peak hours. The reason might be that during the peak hours, the traffic volume is very high and, therefore, there is more constraint in traffic flow and speed. During off-peak hours, on the contrary, drivers have more freedom to choose a speed, which may result in higher traveling speed and, unfortunately, hazardous situations at the curve.

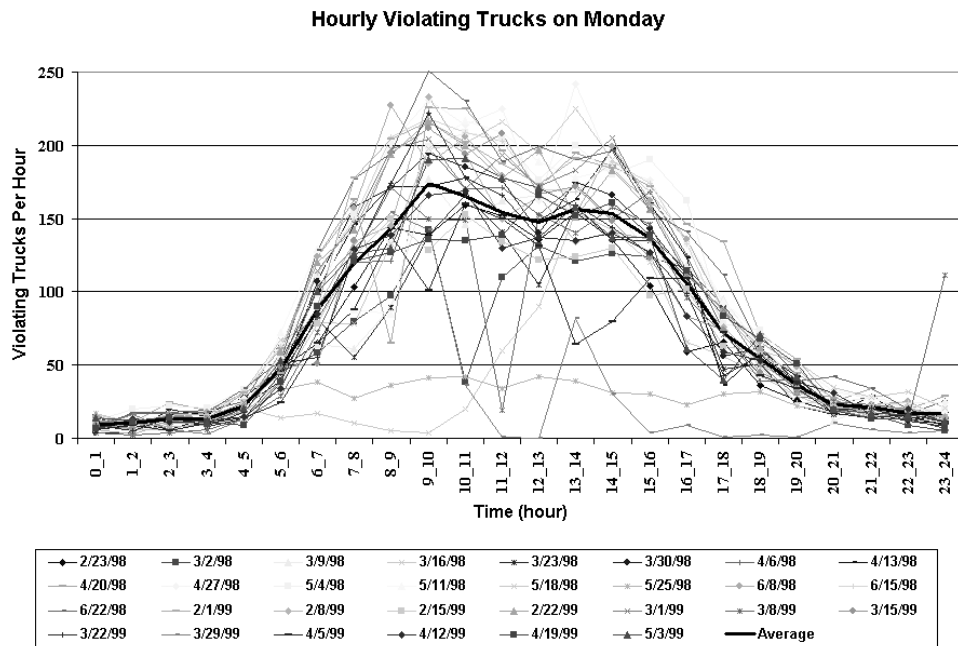

Figure 3.8 Hourly Violating Trucks on Monday



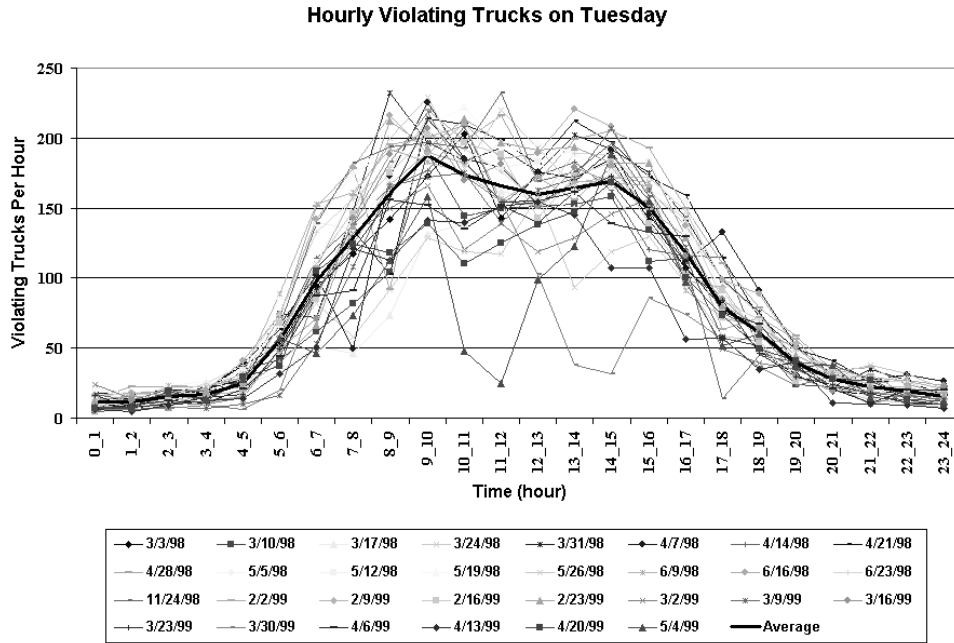

Figure 3.9 Hourly Violating Trucks on Tuesday

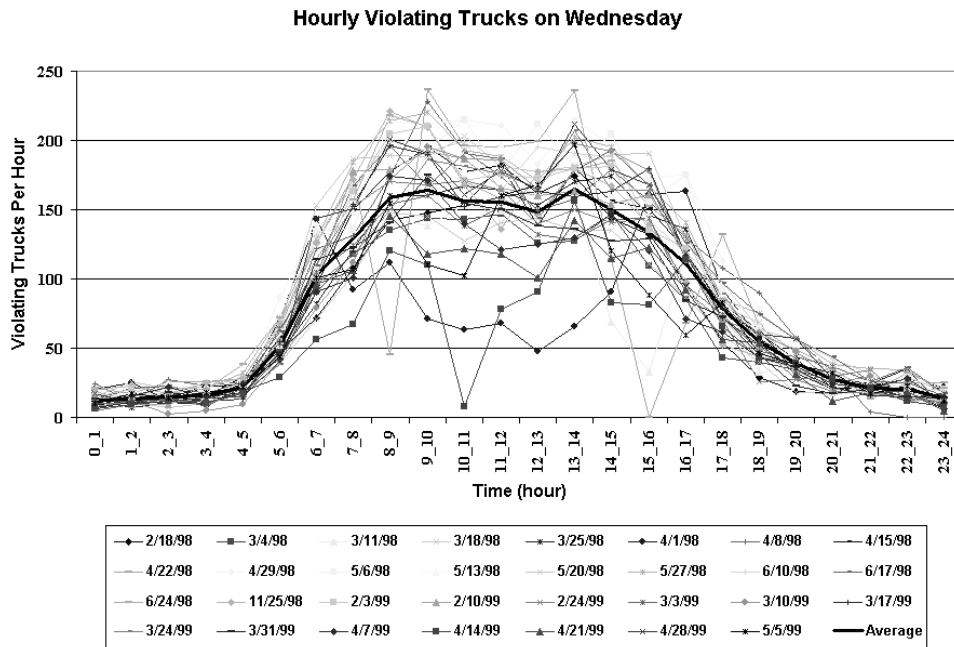

Figure 3.10 Hourly Violating Trucks on Wednesday

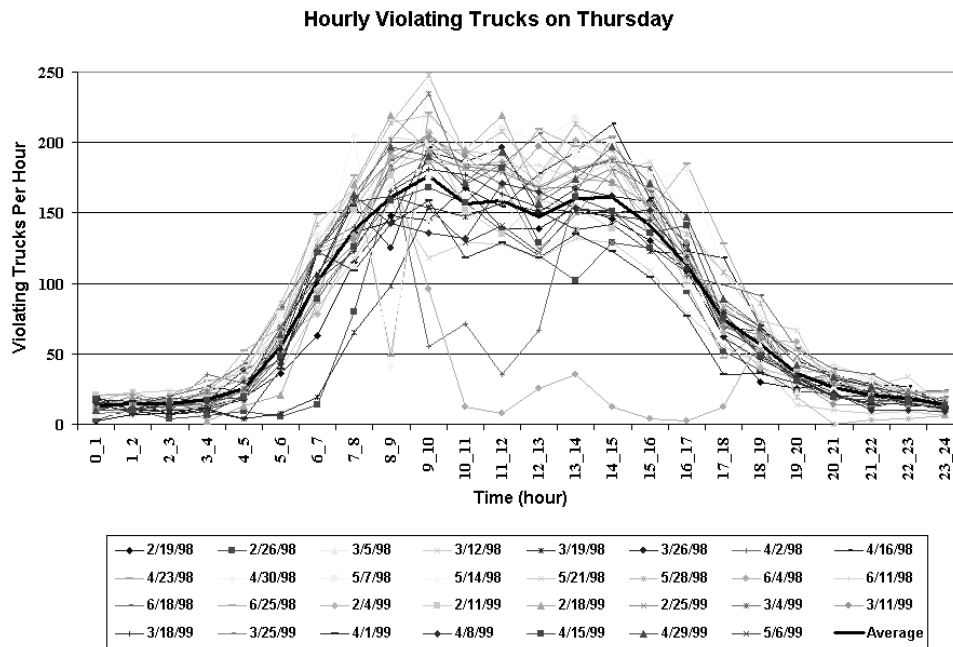

Figure 3.11 Hourly Violating Trucks on Thursday

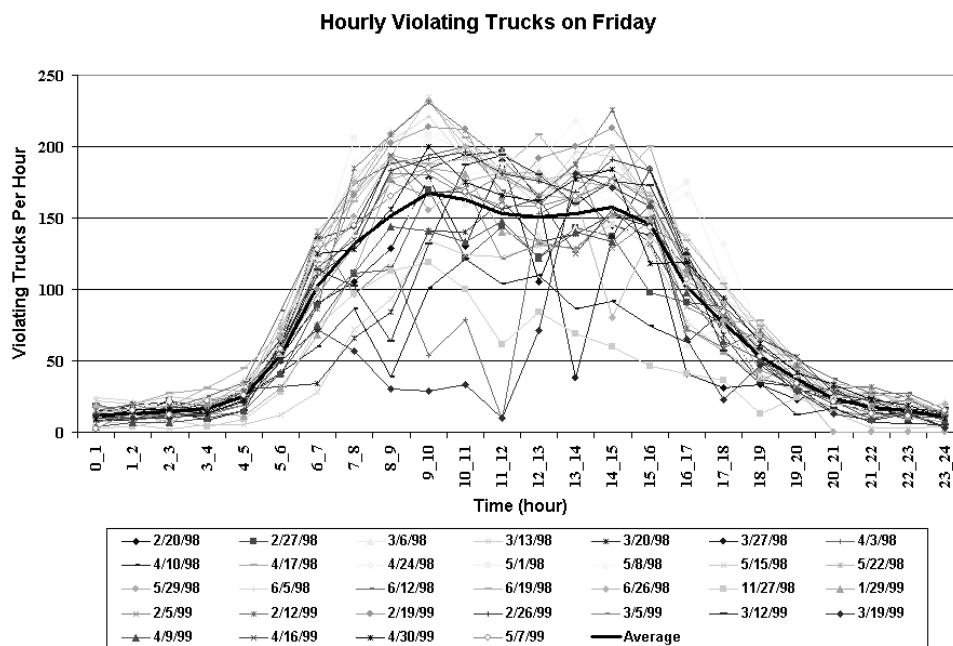

Figure 3.12 Hourly Violating Trucks on Friday

From the summary data shown in Table 3.2, it can be seen that the daily average number of violating trucks was greater on Tuesdays and Thursdays.

Table 3.2 Daily Average Number of Violating Trucks and Peak Hour Volume

<b>Day</b>	<b>Daily Average Number of Violating Trucks (vpd)</b>	<b>Peak Hour Volume (vph)</b>	<b>Peak Hour</b>
<b>Monday</b>	1,898	174	9:00-10:00
<b>Tuesday</b>	2,077	187	9:00-10:00
<b>Wednesday</b>	1,957	164	9:00-10:00
<b>Thursday</b>	2,011	176	9:00-10:00
<b>Friday</b>	1,945	167	9:00-10:00

### ***3.1.4 Speed of Trucks***

In most cases, a truck observed on the exit ramp was traveling in excess of 30 mi/h (48 km/h). Thus, when the violation criteria speed value of the TDA3 was set to 30 mi/h (48 km/h), the data collected by the TDA3 were that for virtually all the trucks, instead of those only for violating trucks.

The speeds of all trucks going faster than 30 mi/h (48km/h) that were observed from Monday to Sunday are shown in Figures 3.13 to 3.19. The cumulative frequency distribution of the truck speed is the familiar S-shaped curve. Most trucks were running within a speed range from 54 mi/h (86 km/h) to 64 mi/h (102 km/h); this is called the 10-mi/h pace. The ratio of the violating trucks (at speeds exceeding 56 mi/h) to the total number of trucks is summarized in Table 3.3. This ratio is higher on Mondays, Tuesdays, and Wednesdays, excluding weekends. When traffic was light, the ratio of violating trucks to total trucks increased.

Table 3.3 Ratio of Violating Trucks to Total Trucks (Weekdays)

Day	Total Trucks	Ratio of Violating Trucks to Total Trucks (%)
Monday	3,022	76
Tuesday	3,109	71
Wednesday	3,202	72
Thursday	3,124	62
Friday	3,134	64
Saturday	982	83
Sunday	707	76

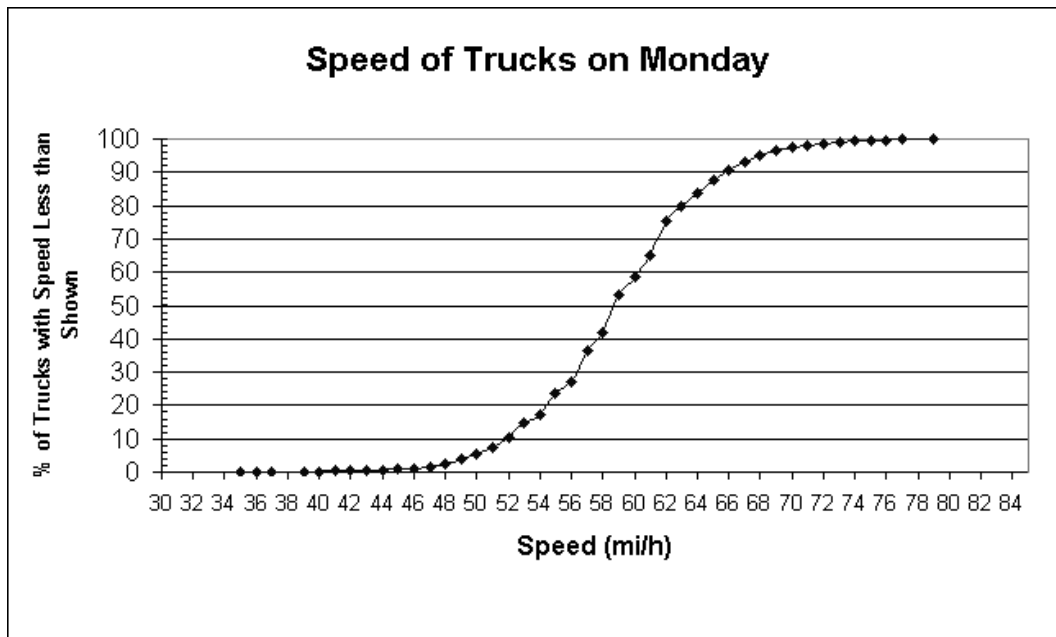

Figure 3.13 Speed of Trucks Faster Than 30 mi/h (48 km/h) and  $\geq 16$  ft (4.9 m) at 7 ft (2.1 m) Height on Monday

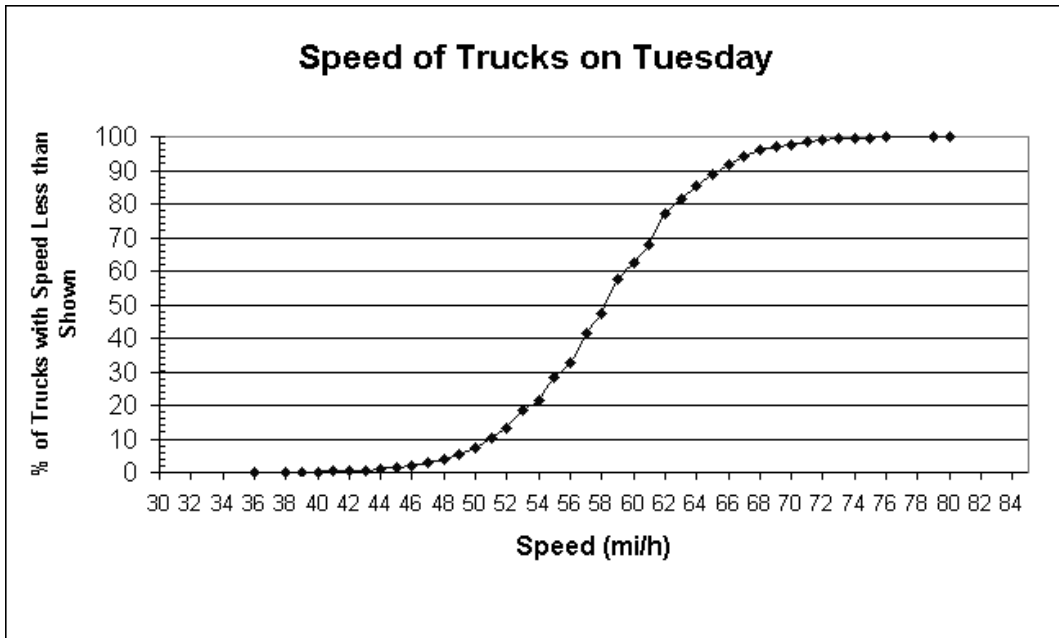

Figure 3.14 Speed of Trucks Faster Than 30 mi/h (48 km/h) and  $\geq 16$  ft (4.9 m) at 7 ft (2.1 m) Height on Tuesday

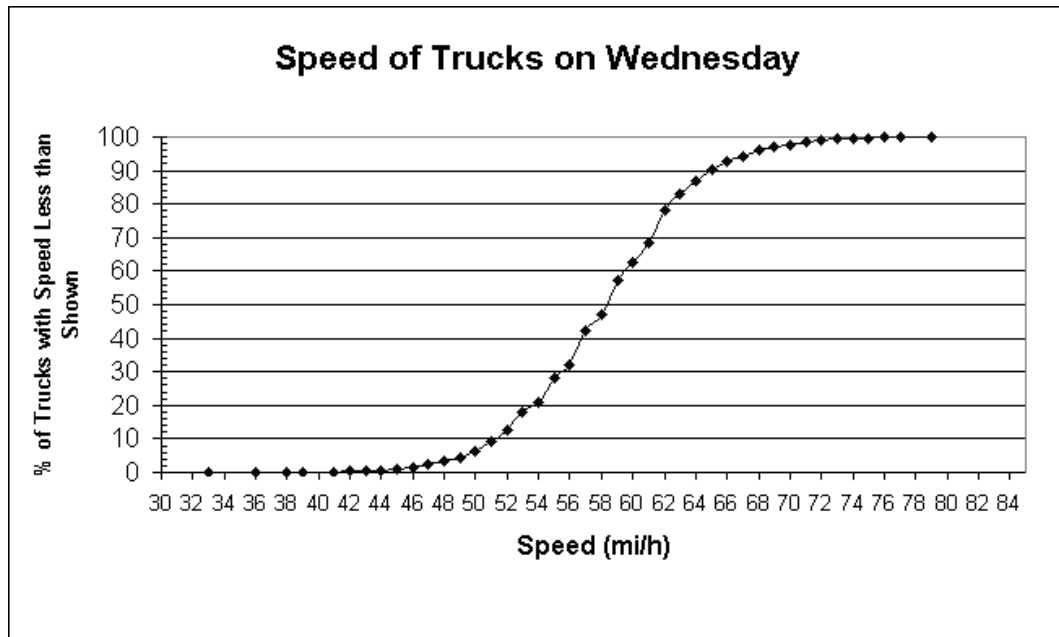

Figure 3.15 Speed of Trucks Faster Than 30 mi/h (48 km/h) and  $\geq 16$  ft (4.9 m) at 7 ft (2.1 m) Height on Wednesday

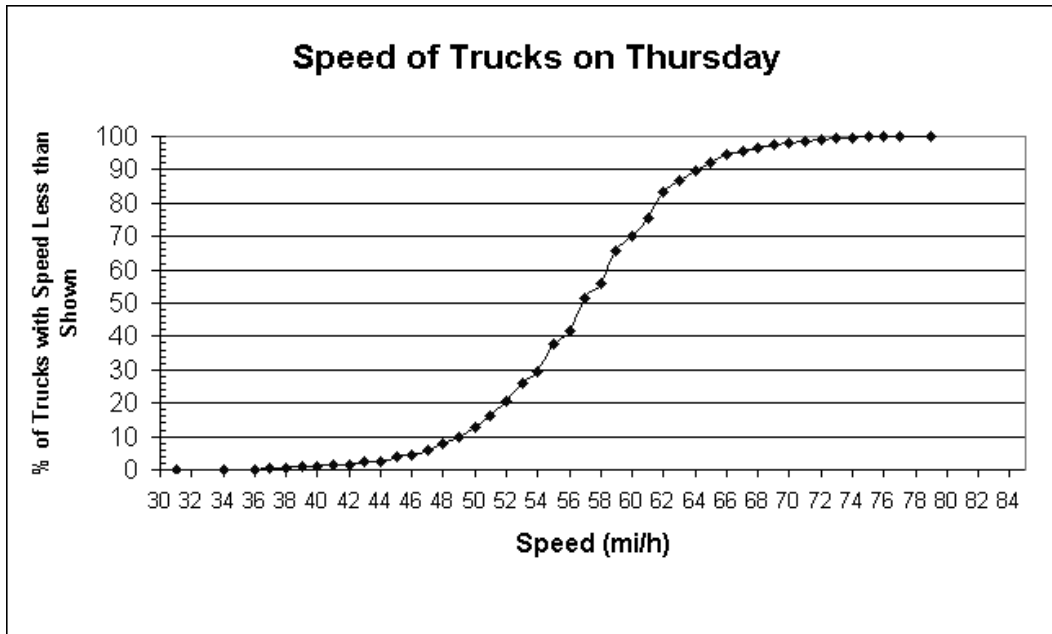

Figure 3.16 Speed of Trucks Faster Than 30 mi/h (48 km/h) and  $\geq 16$  ft (4.9 m) at 7 ft (2.1 m) Height on Thursday

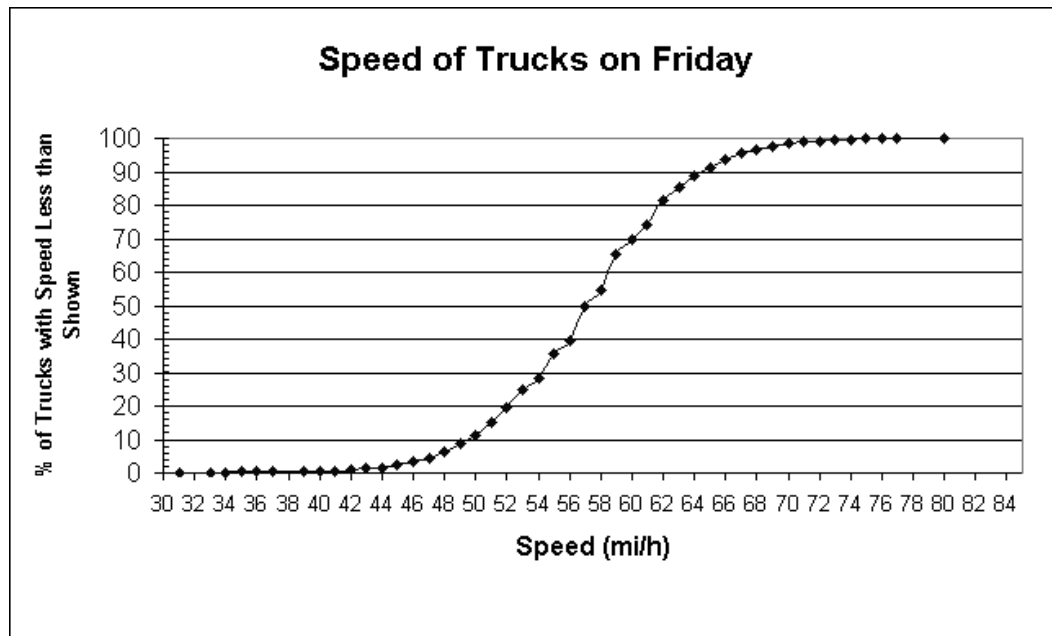

Figure 3.17 Speed of Trucks Faster Than 30 mi/h (48 km/h) and  $\geq 16$  ft (4.9 m) at 7 ft (2.1 m) Height on Friday

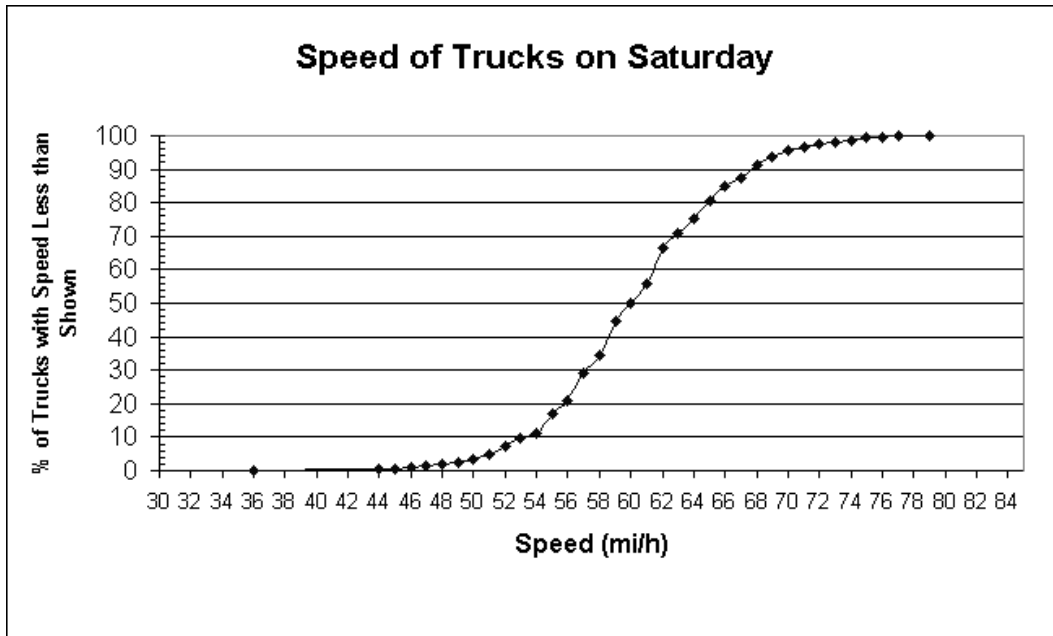

Figure 3.18 Speed of Trucks Faster Than 30 mi/h (48 km/h) and  $\geq 16$  ft (4.9 m) at 7 ft (2.1 m) Height on Saturday

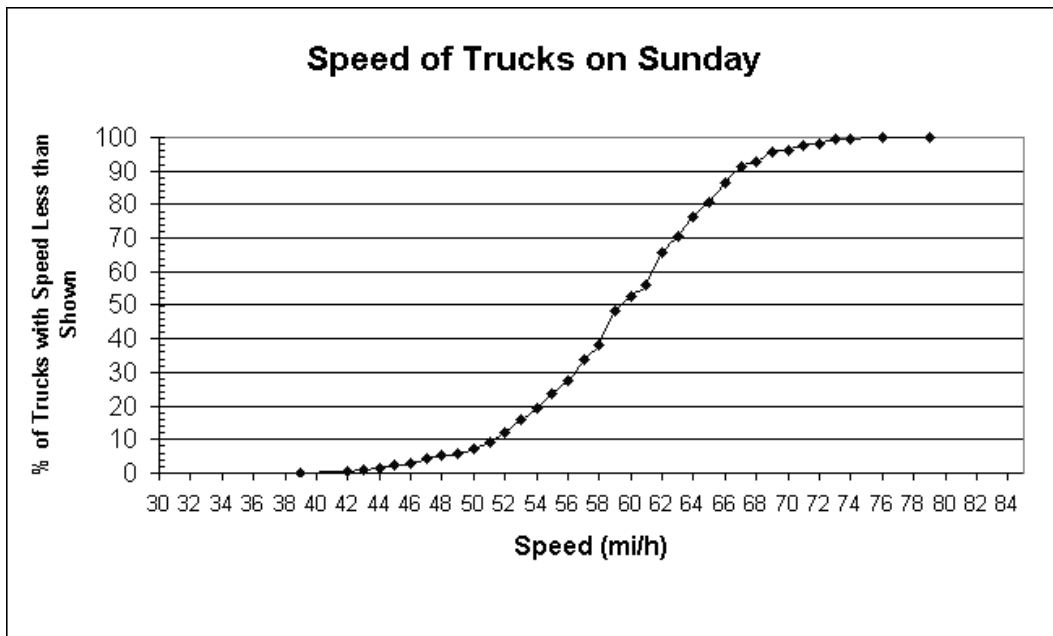

Figure 3.19 Speed of Trucks Faster Than 30 mi/h (48 km/h) and  $\geq 16$  ft (4.9 m) at 7 ft (2.1 m) Height on Sunday

The TDA3 system continuously and reliably provided data for truck monitoring, for more than 2 years. Characteristics of the observed truck traffic derived from analysis of the collected traffic data are:

1. On Tuesdays and Wednesdays, the hourly truck traffic volume was higher and more stable than on other days.
2. The frequency of violating trucks is usually the highest between 9:00 and 17:00, especially on Tuesdays and Wednesdays.

### **3.2 EFFECTIVENESS OF APPLYING THE TDA3 SYSTEM**

The main objective of applying the TDA3 system is to prevent out-of-control accidents of high, long, fast trucks. The critical key to avoiding out-of-control accidents is reducing the speeds of high, long, fast trucks. A before-and-after study was conducted to determine whether the TDA3 system could influence the drivers of high, long, fast trucks to decrease their speeds.

#### ***3.2.1 Layout of Before-and-After Study***

The before-and-after study was designed to compare the speed change of violating trucks as they traveled from the location of the TDA3 (Site 1) to the entry point of the first curve on the ramp (Site 2). The “before” case was conducted without the flashers being actuated by the TDA3 system, and the “after” case had the TDA3 turn the flashers on for every violating truck detected. By comparing the measured speed changes of violating trucks under these conditions, the effectiveness of applying the system could be evaluated.

The same speed measuring techniques were engaged in the conditions with and without warning flashers. The without-flasher sample speed data represents the “before” situation, and the with-flasher samples describe the “after” situation.

##### **3.2.1.1 Matching the Speed Data of Site 1 and Site 2**

The TDA3 system recorded the speed of violating trucks (high, long, fast trucks) at Site 1. Because of the field conditions and cost, there was no TDA3 system at Site 2. To record the speed of violating trucks at Site 2, a traffic data acquisition system named TDA2



was temporarily installed. The TDA2 used the same sensor technologies as those of TDA3, except that only two low IR sensors (2 in. above the road surface) were used to measure the speed and wheelbase of vehicles. It is impossible to compare the vehicle record of TDA2 with that of TDA3 directly because TDA2 lacks the height information. Therefore, another TDA2 system was installed at Site 1, adjacent to the TDA3 warning system (see Figure 3.20). The relations of data measurements for matching the speed change of vehicles among these three systems are shown in Figure 3.21. For convenience, the TDA2 at Site 1 was denoted as TDA2-1 and the one at Site 2 as TDA2-2.

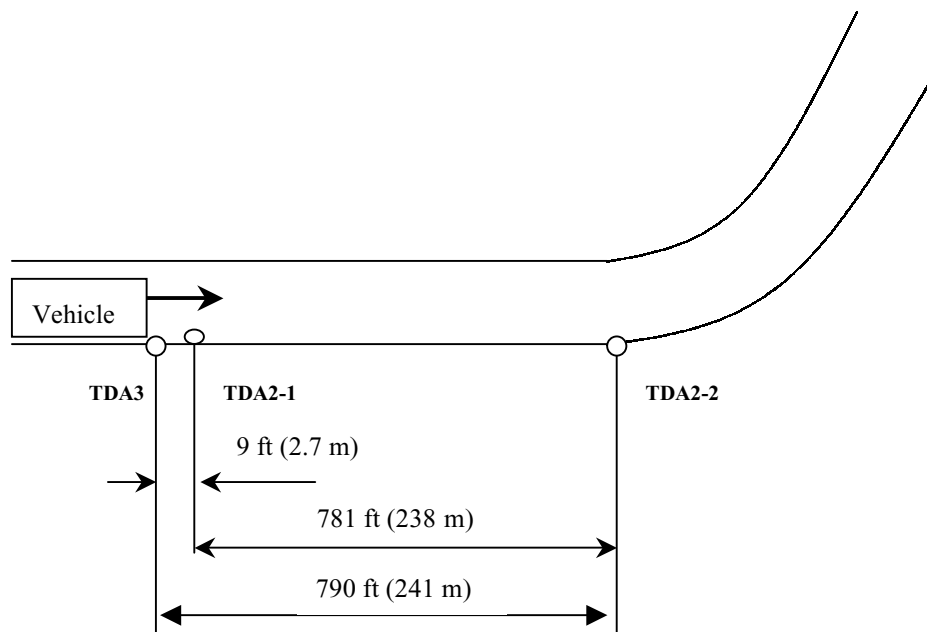

Figure 3.20 Evaluation Test of Speed Change from Site 1 to Site 2

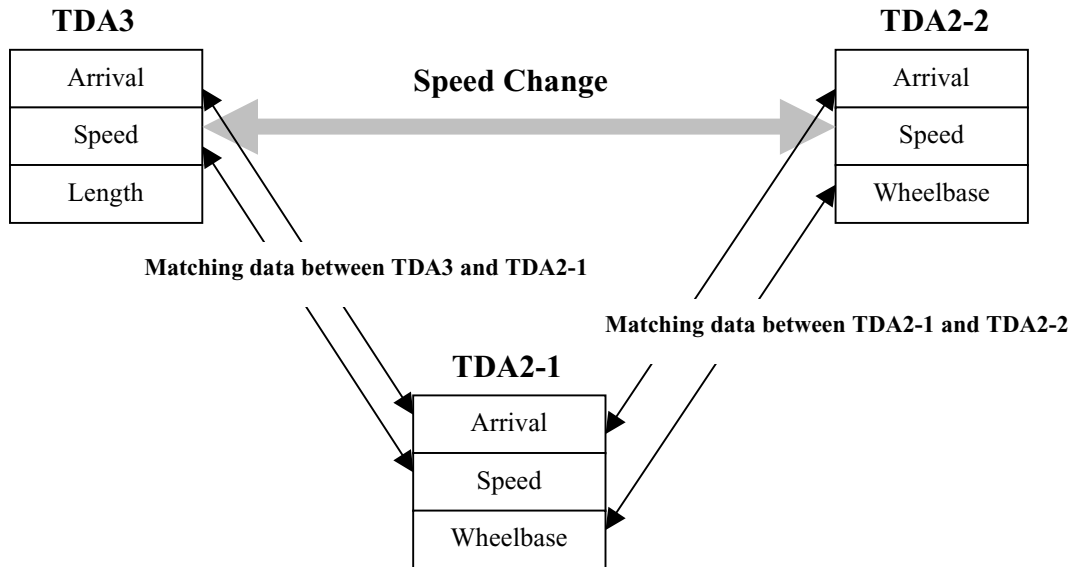

Figure 3.21 Data Relations of the Speed Change Evaluation

TDA2-1 was used to determine an accurate reference speed and wheelbase of a violating truck identified by the TDA3. This speed was then compared to the speed of the same truck when it was later measured by TDA2-2 to calculate speed change. The arrival time and speed were first matched between TDA3 and TDA2-1 to obtain the reference speed and wheelbase data set for individual violating trucks at Site 1; then the arrival time and wheelbase of each vehicle at Site 1 and Site 2 were used to identify the same vehicle at both sites and obtain a corresponding speed data set at Site 2. The two speed observations for the same vehicle were used to calculate the speed change under two different test circumstances: without flashers and with flashers. Patterns of speed changes between the before-and-after conditions were reported based on the two sets of speed change data.

The technique that was developed for identifying the same violating truck at both Site 1 and Site 2 consisted of the two steps described below.

- **Step 1: Matching data records between TDA3 and TDA2-1**

Because TDA3 recorded the speed of only violating trucks while TDA2-1 recorded the speed of all vehicles, only the matched data sets from both systems were of interest. Arrival time and speed were used to find the speed of a particular violating truck (violating determined by TDA3) when its front tires passed the IR light beam of TDA2-1. These

speeds, each with the corresponding wheelbase, comprised the samples at Site 1. The observations were used as the reference in searching for the corresponding speed data recorded on TDA2-2. The distance from TDA3 to TDA2-1 was 9 ft (2.7 m), so there was no significant change in vehicle speed. Taking into consideration the different sensing heights and timer settings on TDA3 and TDA2-1, a 2.0 s time window was used to search for matched data. When the arrival time difference fell into this window and the recorded speeds were within 2 mi/h (3 km/h), the two records were accepted as belonging to the same vehicle. The data set generated by this step was used to identify the violating trucks at Site 1.

- **Step 2: Matching data records between TDA2-1 and TDA2- 2**

The distance between Site1 and Site 2 was 781 ft (238 m). Assuming the truck speed was 60 mi/h (96 km/h), equal to 88 ft/s, the travel time was  $781 \text{ ft}/88 \text{ ft/s} = 8.88 \text{ s}$ . Since individual trucks could have different deceleration rates and the timers of the two TDA2 units were not exactly the same, the time window used for matching data on TDA2-1 and TDA2-2 was set to a range from 7 s to 11 s. First, 7 seconds were added to the arrival time of vehicles recorded on TDA2-1; then, matching data was sought in a 4 s time window in the TDA2-2 data set. If the wheelbase measured by the two TDA2s was within 10 percent, the speed data points would be accepted as belonging to the same truck.

As the ramp under study had two lanes, the footprints of some vehicles could overlap. This overlapping resulted in difficulties in finding the expected vehicles at Site 2. This overlapping phenomenon is described in Figure 3.22. It sometimes reduced the number of matched trucks at Sites 1 and 2.

The matched data of Step 1 and Step 2 were used to calculate the speed changes for the before and after situations, without and with flasher signals.

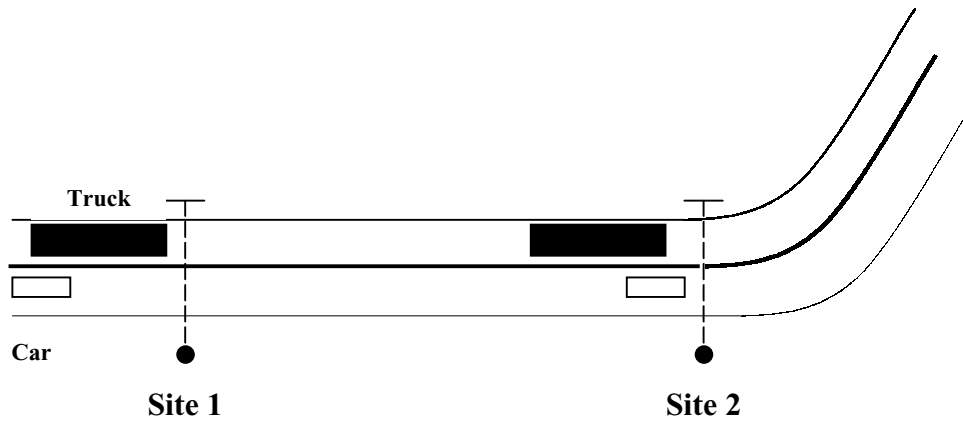

Figure 3.22 Overlapping Phenomenon on the Two-Lane Ramp

### 3.2.1.2 Parameter Setting for TDA2

The parameter settings of TDA2 were almost the same as those of TDA3 except for the filter time. The TDA2 used a longer filter time (0.5 s) than TDA3 (0.4 s). The reasons are:

- 1) The IR light beam of TDA2 was aimed at the tires of the vehicles. The wheelbase of some trucks can be 40 ft (12.1 m) long (see Figure 3.23). Assuming the speed of the truck was 55 mi/h (88 km/h), equal to 80 ft/s, the travel time of the truck to move a length of one wheelbase was around 0.5 s. Accordingly, a filter time of 0.5 s was necessary to make sure that a truck with a long wheelbase would not be recorded as two short vehicles.
- 2) When the headway of two small vehicles was less than the filter time, the two vehicles would be recorded as one long vehicle. These records, however, could be eliminated after matching them with the data of TDA3, because the data of small vehicles were not recorded by TDA3.

### 3.2.1.3 Observation Period

An important decision in any before-and-after study is the appropriate observation period. In order to make the samples more representative of the population, the appropriate observation period should be the time when the hourly traffic volume is most stable and the frequency of violating trucks is highest.

According to the traffic analysis described in Sections 3.1.1 to 3.1.4, the time period (24-hour clock) from 09:00 to 17:00 on Tuesdays or Wednesdays was selected as the time frame for collecting sample data and analyzing the effectiveness of the warning system on the ramp traffic.

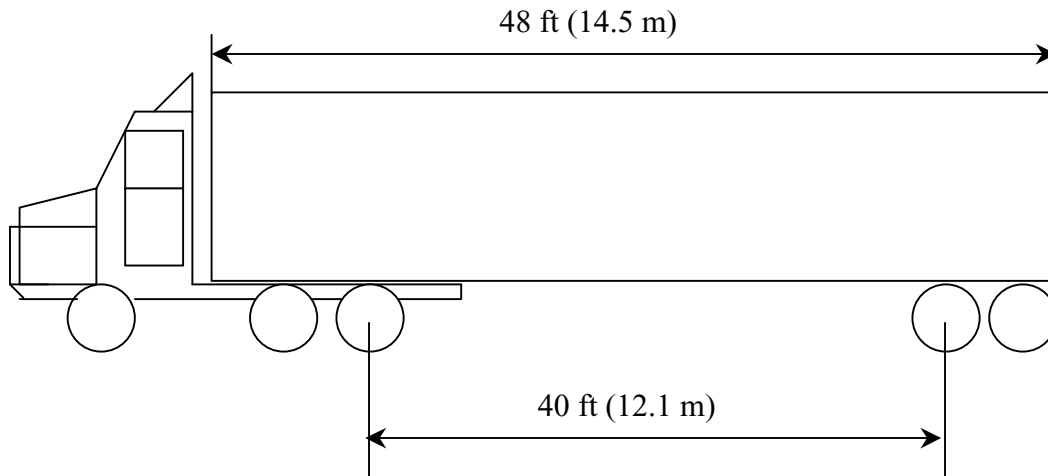

Figure 3.23 Wheelbase of a Large Truck

### 3.2.2 Before Study

Observation period (24-hour clock): 11:55:30 to 15:24:57 on Tuesday, January 26, 1999.

#### System Settings:

System	Filter time	Speed criteria	Flasher time
TDA3	0.4 s	56 mi/h (90 km/h)	12 s
TDA2	0.5 s		

During this observation period, 141 trucks were positively matched among all three detector stations (see Table 3.4).

Table 3.4 Data Matching between Site 1 and Site 2 in “Before” Study

	TDA2-1	TDA3	Matched with TDA2-1 and TDA3	TDA2-2	Matched among Three Systems
<b>Number of Samples</b>	3,483	579	344	3,794	141

The difference between sample sizes of TDA2-1 and TDA2-2 was probably due to the overlapping phenomenon of vehicles on the two-lane ramp.

The normal speed reduction of 141 violating trucks from Site 1 to Site 2, with no flasher warning system, is shown graphically in Figures 3.24 to 3.28. This speed reduction was due to the driver’s normal response to the road geometry, traffic control devices, and other vehicles. The time headway between successive violating trucks can also be determined from the plotted data.

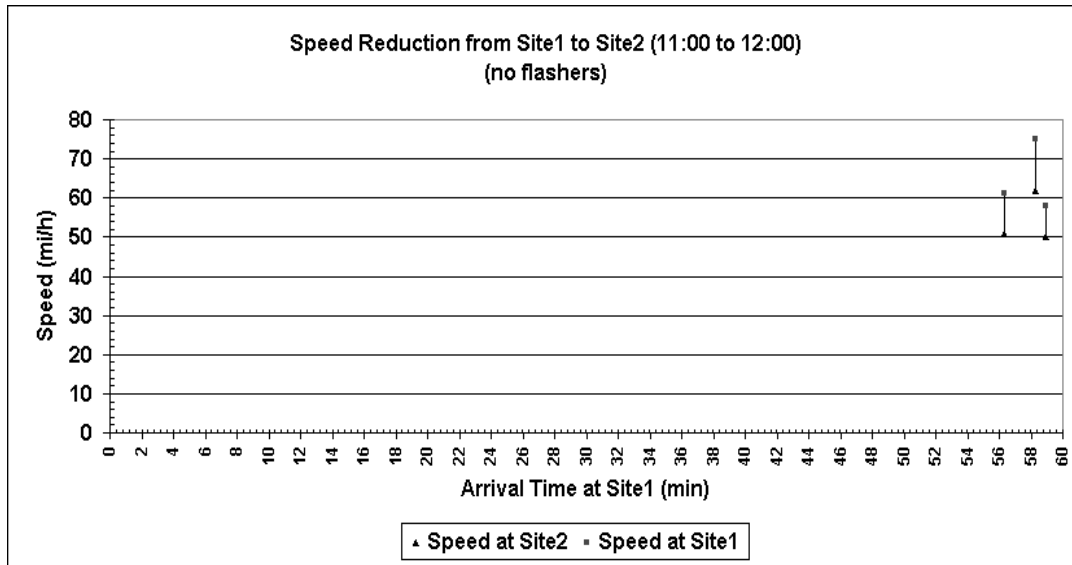

Figure 3.24 Speed Reduction of Violating Trucks from Site 1 to Site 2 (11:00 to 12:00), No Flashers

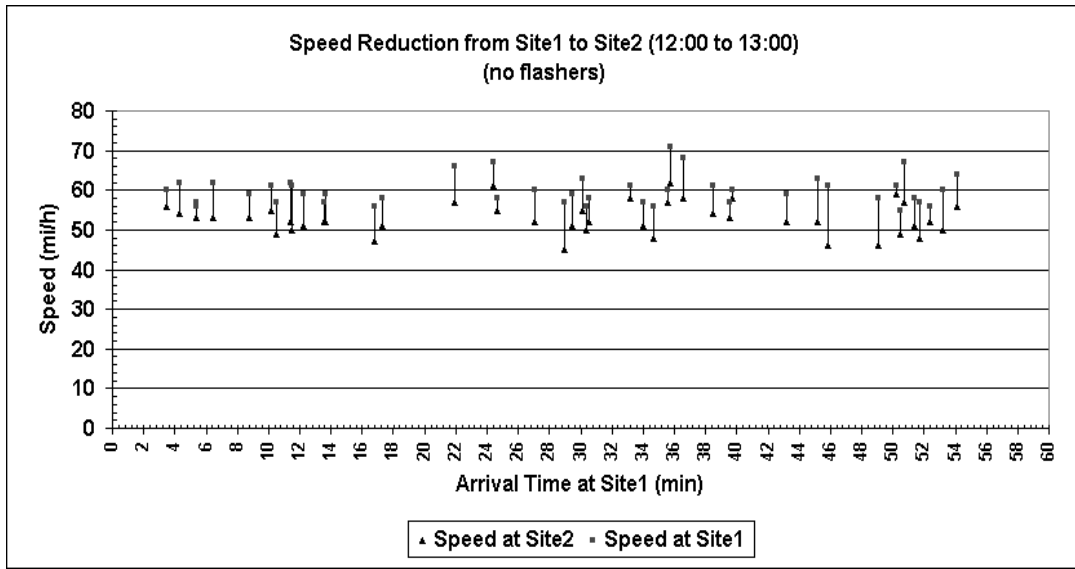

Figure 3.25 Speed Reduction of Violating Trucks from Site 1 to Site 2 (12:00 to 13:00), No Flashers

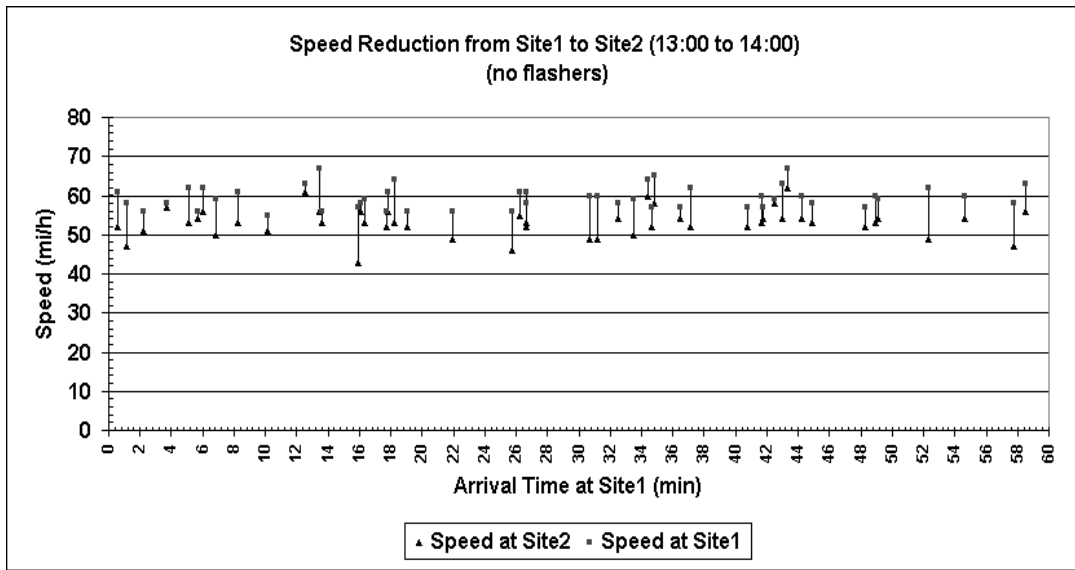

Figure 3.26 Speed Reduction of Violating Trucks from Site 1 to Site 2 (13:00 to 14:00), No Flashers

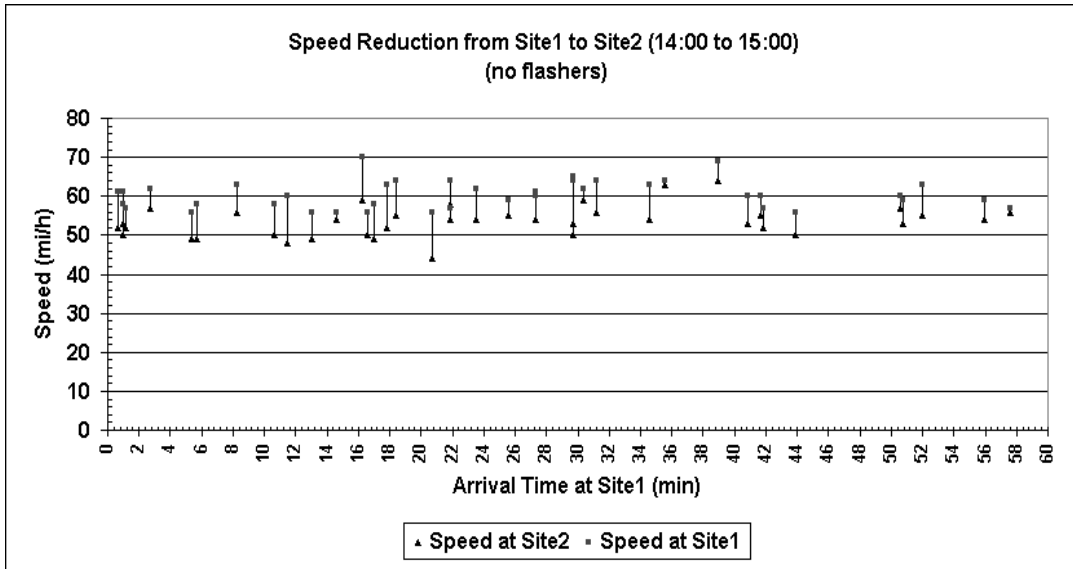

Figure 3.27 Speed Reduction of Violating Trucks from Site 1 to Site 2 (14:00 to 15:00), No Flashers

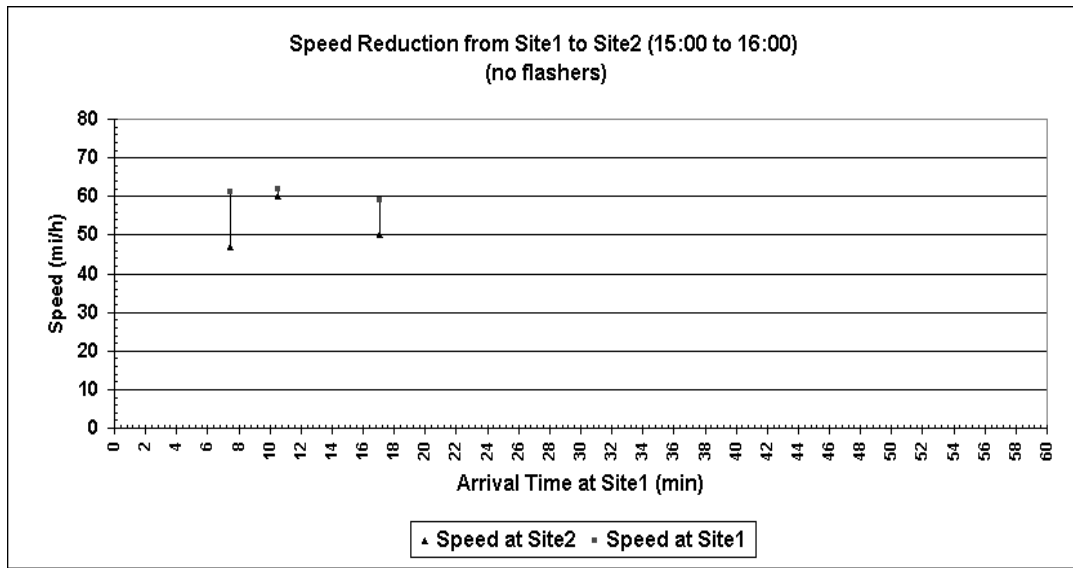

Figure 3.28 Speed Reduction of Violating Trucks from Site 1 to Site 2 (15:00 to 16:00), No Flashers



### 3.2.3 After Study

Observation period (24-hour clock): 10:18:18 to 14:52:33 and 15:22:38 to 17:03:57 on Wednesday, February 17, 1999

The monitoring system settings were the same as for the “before” study.

In the “after” study, when a high, long, fast vehicle was detected by the TDA3 system, the driver was warned of the potential hazard ahead by the illumination of three flashing signals located along the edge of the ramp. The warning signals were activated only if a vehicle was longer than 16 ft (4.9 m) at the height of 7 ft (2.1 m) and running faster than 56 mi/h (90 km/h). A total of 280 violating trucks that met all the matching conditions (see Table 3.5) were detected by the TDA3 system during the “after” study.

Table 3.5 Data Matching between Site 1 and Site 2 in “After” Study

	TDA2-1	TDA3	Matched with TDA2-1 and TDA3	TDA2-2	Matched among Three Systems
Number of Samples	5,802	1,105	702	6,506	280

The calculated speed reduction for each of these 280 violating trucks, with the flasher warning system activated, is plotted in Figures 3.29 to 3.36.

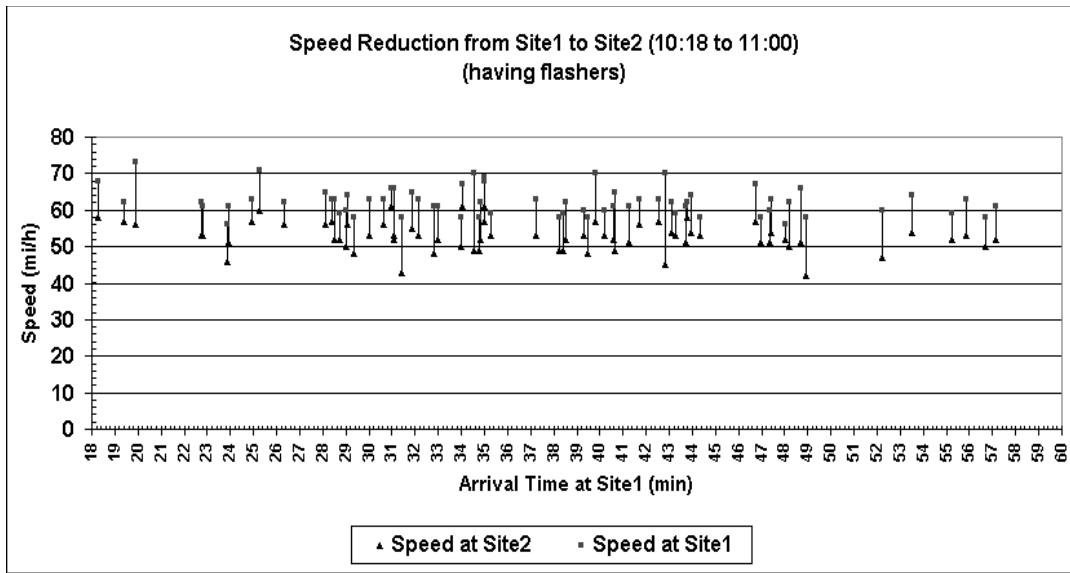

Figure 3.29 Speed Reduction of Violating Trucks from Site 1 to Site 2 (10:18 to 11:00), Having Flashers

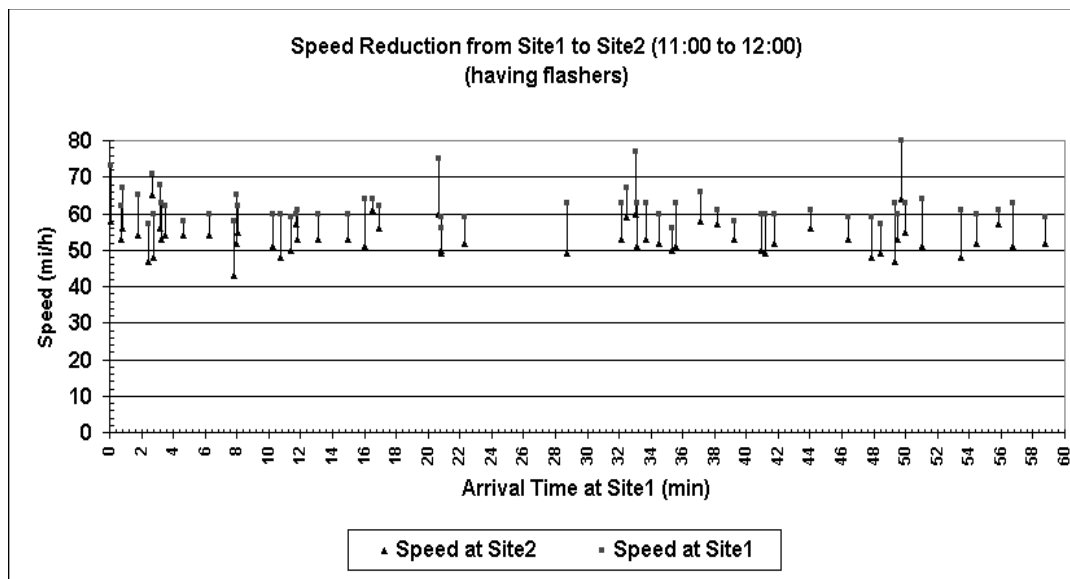

Figure 3.30 Speed Reduction of Violating Trucks from Site 1 to Site 2 (11:00 to 12:00), Having Flashers

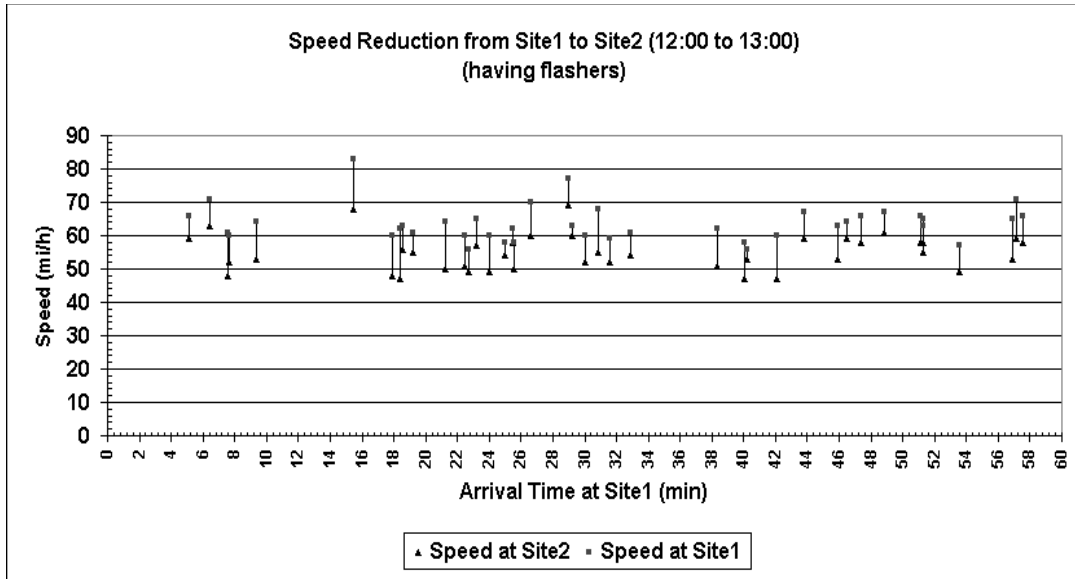

Figure 3.31 Speed Reduction of Violating Trucks from Site 1 to Site 2 (12:00 to 13:00), Having Flashers

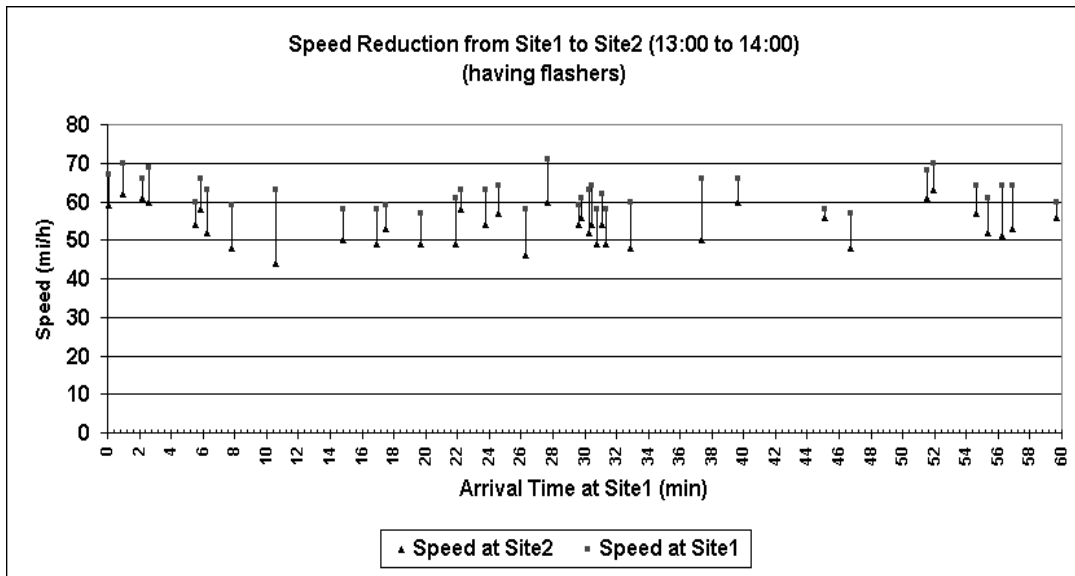

Figure 3.32 Speed Reduction of Violating Trucks from Site 1 to Site 2 (13:00 to 14:00), Having Flashers

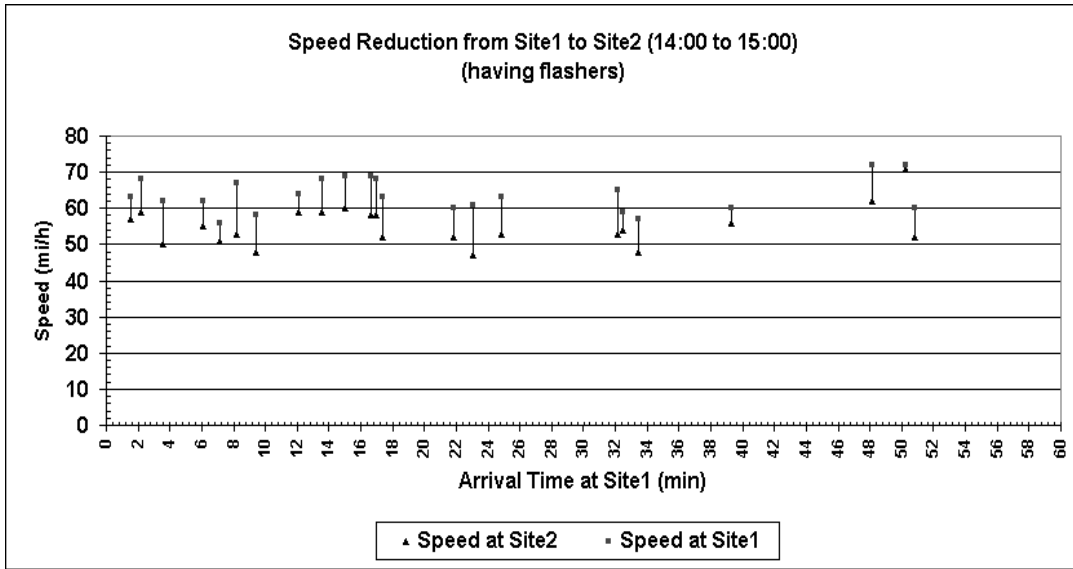

Figure 3.33 Speed Reduction of Violating Trucks from Site 1 to Site 2 (14:00 to 15:00), Having Flashers

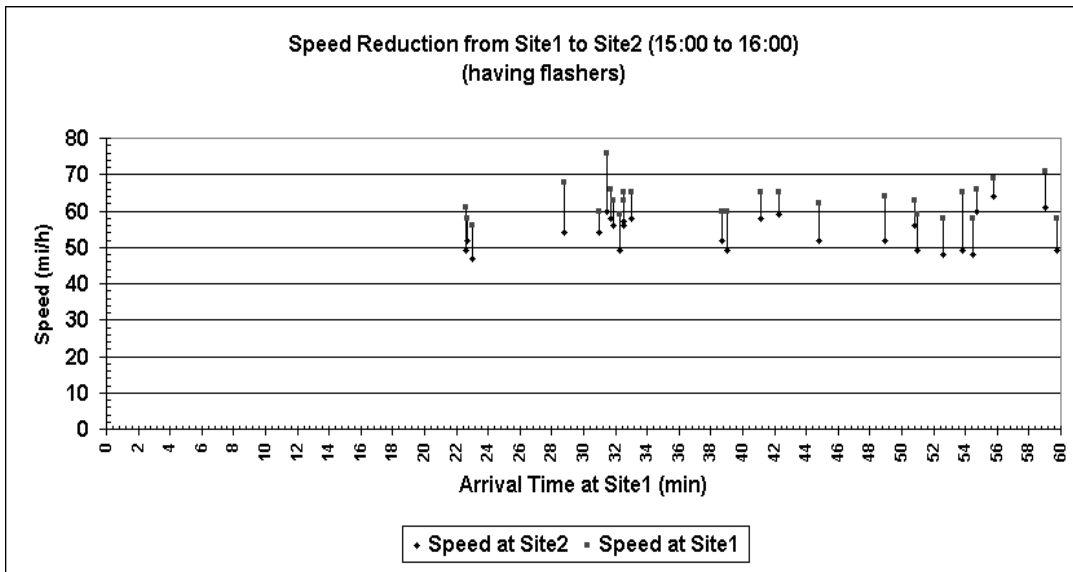

Figure 3.34 Speed Reduction of Violating Trucks from Site 1 to Site 2 (15:00 to 16:00), Having Flashers

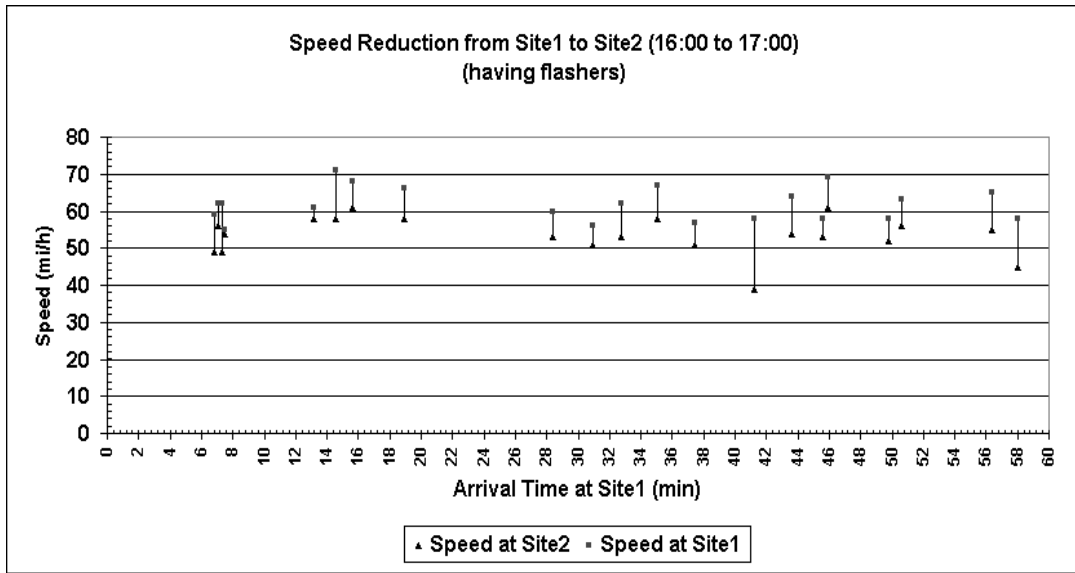

Figure 3.35 Speed Reduction of Violating Trucks from Site 1 to Site 2 (16:00 to 17:00), Having Flashers

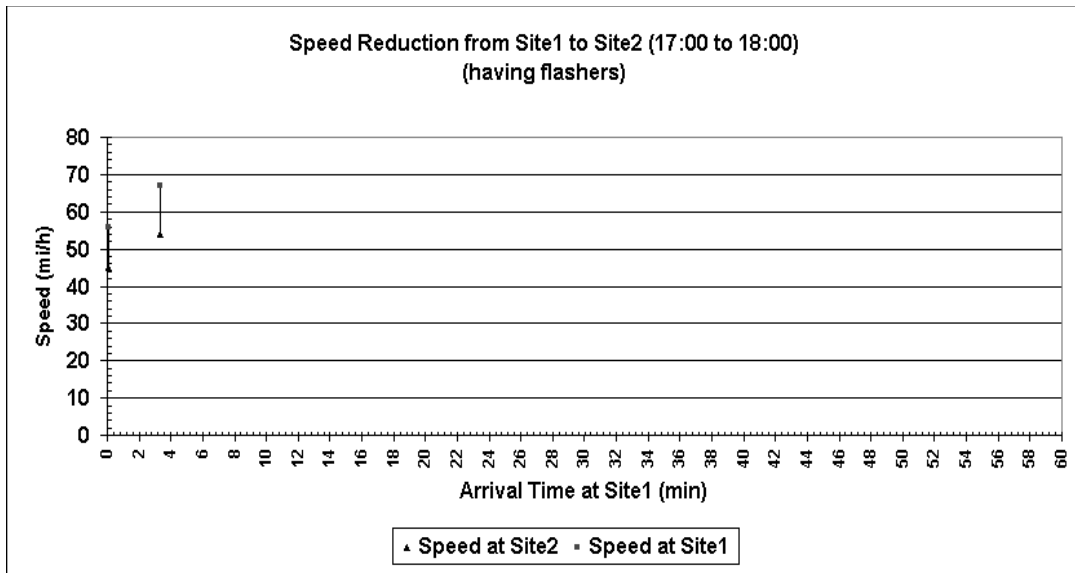

Figure 3.36 Speed Reduction of Violating Trucks from Site 1 to Site 2 (17:00 to 18:00), Having Flashers

### ***3.2.4 Analysis of Speed Changes in the Before-and-After Case Studies***

In the “before” case, trucks operated in the prevailing traffic, on the existing ramp geometry, and with the traffic control devices described in Chapter 2 in place. The posted speed limit was 60 mph (96 km/h) on the main lanes of I-610, from which traffic exited onto the tapered ramp terminal. The grade of the main lanes and the ramp terminal was -2.4 percent (downgrade) at the gore area. The straight portion of the ramp extended some 950 ft (290 m) from the physical nose of the tapered ramp terminal to the beginning of the first horizontal curve to the left, which has a radius of 5,730 ft (1,747 m). The TDA3 and the TDA2-1 sensors were located about 80 ft (24 m) downstream from the nose, and the TDA2-2 sensors were 781 ft (238 m) further downstream on the straight portion of the ramp about 90 ft (27 m) in advance of the beginning of the horizontal curve. When vehicles passed the TDA2-1 sensors, they were on a -2.4 percent grade; they then traversed a 250 ft (76 m) long sag vertical curve to enter a +2.5 percent grade (upgrade), which continued into the curved portion of the ramp. Thus, the force of gravity acted to slow vehicles as they traveled the last 500 ft (150 m) or so between the speed measuring devices TDA2-1 and TDA2-2. Every observed truck included in the “before” and in the “after” case studies, in fact, decreased its speed while traveling on the straight, upgrade portion of the ramp between these two speed traps.

In the “after” case, all geometric and traffic control device conditions were the same as for the “before” case, except that the TDA3 system activated the flashers whenever a truck violated the preset warning criteria. It was reasoned that if the speed reduction values observed in the “after” case (with flashers) were significantly greater than those for the “before” case, the warning flashers probably had an appropriate effect upon the driver’s choice of speed for entering the potentially hazardous, curved portion of the ramp. As traffic operating conditions on the ramp normally induced a speed reduction for all observed trucks, it was the magnitude of the difference in speed reduction, or the additional speed reduction, that could indicate the effect of activating the flashers only for violating trucks — the “after” case conditions.

After the speed measurements were matched for the same violating truck passing through all three speed traps (TDA3, TDA2-1, and TDA2-2), 141 pairs of speed data measurements were obtained in the “before” case, and 280 pairs in the “after” case. The speed change — always a speed reduction in both cases — was calculated as the speed at TDA2-1 minus the speed at TDA2-2. It is important to note that only the trucks traveling at or above 56 mi/h (90 km/h) were considered to be violating trucks.

In analyzing the two data sets to determine whether the activation of the warning flashers had a significant effect upon speed reduction, it was desirable to stratify the data sets according to (1) different speed ranges (at Site 1, i.e., at the TDA2-1 location), and (2) different time headway between pairs of successive violating trucks, also observed at this site. The results of the analyses are presented in the following sections.

#### **3.2.4.1 Divide Data Set According to Different Speed Ranges**

In recognition of the fact that the posted speed limit was 60 mph (96 km/h) on the main lanes of I-610, from which traffic exited onto the tapered ramp terminal, and that only the trucks traveling at or above 56 mi/h (90 km/h) were considered to be violating trucks, the “before” and the “after” data sets were divided into the following arbitrarily-chosen speed categories or ranges.

- 1) Speed less than 62 mi/h (99 km/h) at Site 1.
- 2) Speed between 62 mi/h (99 km/h) and 70 mi/h (112 km/h) at Site 1.
- 3) Speed faster than 70 mi/h (112 km/h) at Site 1.

The results of comparing the observed violating truck speeds in the “before” and “after” cases — without and with the TDA3 system activating the warning flashers, respectively — are summarized in Table 3.6.

Table 3.6 Comparison of Speed in the Before-and-After Cases by Speed Range

Speed Range (mi/h)	Condition	Speed at Site1	Speed at Site2	Average Speed Reduction (mi/h)	Diff of Speed Reduction (mi/h)	STDEV of Speed Reduction	Sample Size
< 62mi/h	Before	58	52	6	2	3.04	100
	After	59	51	8		3.19	125
62 to 70 mi/h	Before	64	56	8	2	3.05	39
	After	65	55	10		3.43	138
> 70 mi/h	Before	73	62	11	1	2.83	2
	After	74	62	12		4.39	17

In both cases, the average speed reduction by higher-speed trucks was greater than that by lower-speed trucks, and the average speed reduction was greater in the “after” case when the TDA3 system actuated the flashers to warn only violating trucks. In order to determine whether the additional speed reduction was likely to be due to random variation or probably due to the effect of the flashers, a hypothesis test was needed. The statistical test represented in the following equation (see Ref 9) was used.

$$T = \frac{(\bar{X}_1 - \bar{X}_2)}{\sqrt{\left(\frac{S_1^2}{n_1}\right) + \left(\frac{S_2^2}{n_2}\right)}} \quad (\text{Eq 3.1})$$

This statistic has approximately a *t*-distribution with *v* degrees of freedom, where

$$v = \frac{\left(\frac{S_1^2}{n_1} + \frac{S_2^2}{n_2}\right)^2}{\left[\frac{\left(\frac{S_1^2}{n_1}\right)^2}{(n_1 - 1)}\right] + \left[\frac{\left(\frac{S_2^2}{n_2}\right)^2}{(n_2 - 1)}\right]} \quad (\text{Eq 3.2.})$$

In these two equations, *T* is the *t* score for observed data,

*S*<sub>1</sub>, *S*<sub>2</sub> are the standard deviations of two samples,



$\bar{X}_1, \bar{X}_2$  are means of two samples,  
 $n_1, n_2$  are sample sizes of two samples, and  
 $\nu$  is the degrees of freedom.

A condition for applying this test appropriately is that the frequency distribution of the data sets be normally distributed. In order to determine whether these samples were normally distributed or not, the Quantile-Normal Plot was used. The Quantile-Normal Plot, sometimes called a normal probability plot, allows comparisons between an empirical and a theoretical distribution. If the empirical distribution is normal, all points will lie on a straight, diagonal line (Ref 14). The calculated speed difference values for the stratified data sets in the “before-and-after” case studies were plotted using SPSS 8.0 (see Ref 16), and the results are shown in Figures 3.37 to 3.40. As the plotted speed reduction values shown in these figures lie approximately along the diagonal line of normality, application of the statistical test seemed appropriate to test the following hypotheses.

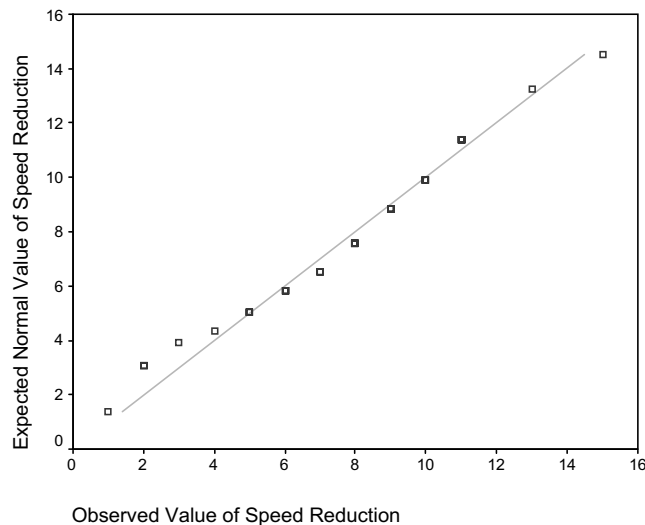

Figure 3.37 Quantile-Normal Plot of Speed Reduction in Which the Original Speeds Were Between 62 mi/h and 70 mi/h and Warning System Was Not Active (“Before” Case)

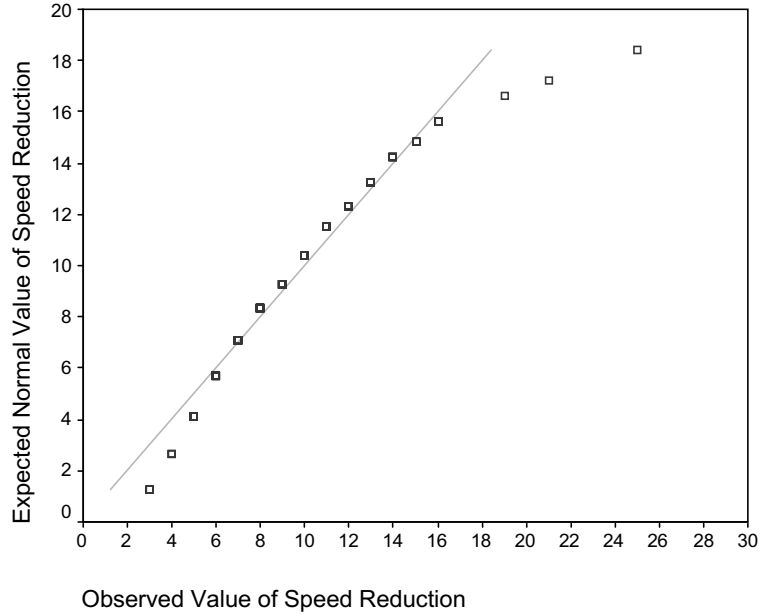

Figure 3.38 Quantile-Normal Plot of Speed Reduction in Which the Original Speeds Were Between 62 mi/h and 70 mi/h and Warning System Was Active (“After” Case)

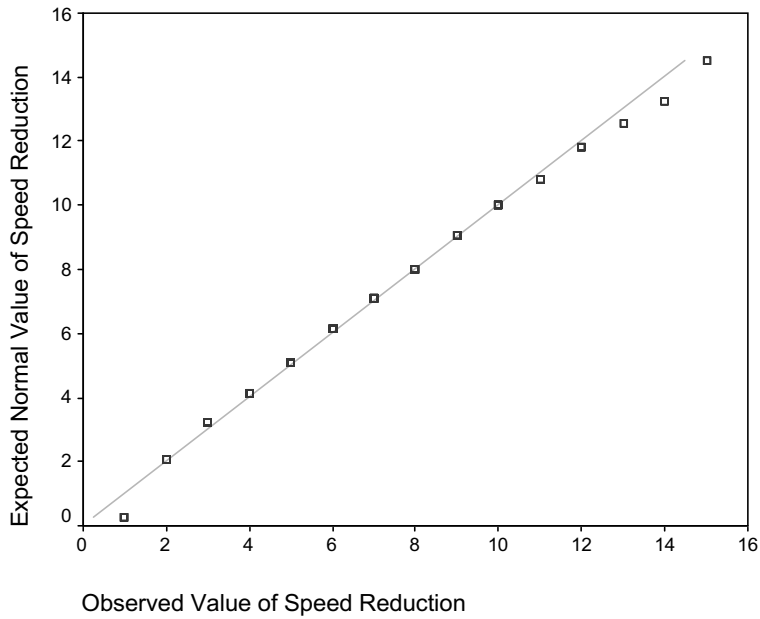

Figure 3.39 Quantile-Normal Plot of Speed Reduction in Which the Original Speeds Were Less Than 62 mi/h and Warning System Was Not Active (“Before” Case)

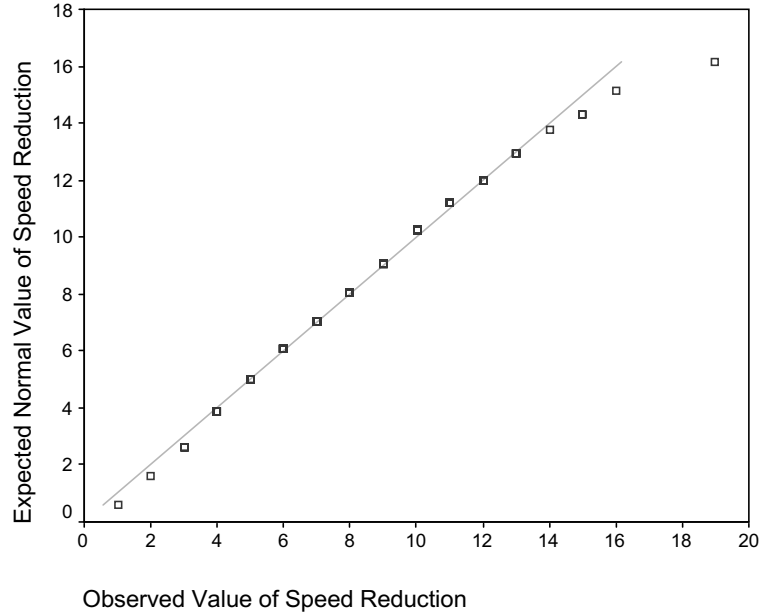

Figure 3.40 Quantile-Normal Plot of Speed Reduction in Which the Original Speeds Were Less Than 62 mi/h and Warning System Was Active (“After” Case)

$H_0 : \Delta S_a - \Delta S_b = 0$  Average speed reduction of violating trucks without (“before” case) and with (“after” case) warning flashers is the same.

$H_1 : \Delta S_a - \Delta S_b > 0$  The average speed reduction of violating trucks is greater with (“after” case) warning flashers.

Where:  $\Delta S_a$  is the average speed reduction of violating trucks with warning flashers, and  $\Delta S_b$  is the average speed reduction of violating trucks without warning flashers.

Reference Eq 3.1 and 3.2. to calculate degree of freedom and the  $T$  score for observed data.

1. Speed range less than 62 mi/h (99 km/h)

$$T = \frac{\Delta S_a - \Delta S_b}{\sqrt{\frac{S_{\Delta S_a}^2}{m} + \frac{S_{\Delta S_b}^2}{n}}} = \frac{8 - 6}{\sqrt{\frac{3.19^2}{125} + \frac{3.04^2}{100}}} = 4.80 \quad (\text{Eq 3.3})$$

Where:  $S$  is the standard deviation of speed reduction in the “before” case and “after” case, respectively, and  $m$  and  $n$  are the respective sample sizes.

$$v = \frac{\left( \frac{3.19^2}{125} + \frac{3.04^2}{100} \right)^2}{\left[ \frac{\left( \frac{3.19^2}{125} \right)^2}{125 - 1} \right] + \left[ \frac{\left( \frac{3.04^2}{100} \right)^2}{100 - 1} \right]} = 216 \quad (\text{Eq 3.4})$$

The critical  $T$  score corresponding to the significance level of 99 percent is 2.576. As the observed  $T$  value, 4.80, is greater than the critical  $T$  score, the warning system can be said to have produced a statistically significant speed reduction of high, long, fast vehicles running less than 62 mi/h (99 km/h) with more than 99 percent confidence.

2. Speed range between 62 mi/h (99 km/h) and 70 mi/h (112 km/h)

$$T = \frac{10 - 8}{\sqrt{\frac{3.43^2}{138} + \frac{3.05^2}{39}}} = 3.51 \quad (\text{Eq 3.5})$$

$$v = \frac{\left( \frac{3.43^2}{138} + \frac{3.05^2}{39} \right)^2}{\left[ \frac{\left( \frac{3.43^2}{138} \right)^2}{138 - 1} \right] + \left[ \frac{\left( \frac{3.05^2}{39} \right)^2}{39 - 1} \right]} = 68 \quad (\text{Eq 3.6})$$

The critical  $T$  score corresponding to the significance level of 99 percent is 2.576. As the observed  $T$  score, 3.51, is greater than the critical score, the warning system can again be said, with more than 99 percent confidence, to have produced a statistically significant speed

reduction of high, long, fast vehicles running between 62 mi/h (99 km/h) and 70 mi/h (112 km/h).

3. Speed greater than 70 mi/h (112 km/h)

Since the sample size is so small (only two observations), it does not provide sufficient data for statistical analysis.

**3.2.4.2 Divide Data Set According to Different Headways.**

A factor that influences a driver’s choice of speed at a given instant is the time headway between successive vehicles. When the headway behind the vehicle ahead is long, e.g., traffic volume is low, the driver can freely choose a speed without being influenced by the vehicle ahead, but, as the headway decreases, the chosen speed can be affected by the proximity to the vehicle ahead. In order to analyze the possible effect of such interaction between pairs of violating trucks, the data sets of truck speeds for the Before-and-After case studies were each divided into two headway groups: (1) violating trucks traveling with, or less than, 0.1 minute (6 seconds) headway behind the violating truck ahead, and (2) those with headway greater than this. The calculated values related to observed speed reduction during the Before-and-After case studies are summarized in Table 3.7.

Table 3.7 Speed Reduction in Different Time Headway Groups

Headway (minute)	Sample Size		Average Speed Reduction		Diff of Speed Reduction	St Dev of Speed Reduction	
	Before Case	After Case	Before Case	After Case		Before Case	After Case
<= 0.1	12	24	7 mi/h (11 km/h)	9 mi/h (14 km/h)	2 mi/h (3 km/h)	2.84	2.78
> 0.1	129	255	7 mi/h (11 km/h)	9mi/h (14 km/h)	2 mi/h (3 km/h)	3.16	3.48

The data shown in Table 3.7 suggest that the greater the headway, the greater the variation in speed reduction, as indicated by the standard deviation statistic. The data also

show that the difference of average speed reduction (2 mi/h [3 km/h]) was the same for both headway groups.

Data values plotted in Figures 3.41 through 3.44 suggest that the frequency of observed speed measurements (speed reduction values) is approximately normally distributed. Thus, it is appropriate to use the same statistical testing technique as was employed in the previous section to test the hypothesis that there was a statistically significant effect on speed reduction caused by actuating the flashers to warn high, long, fast trucks of impending hazard.

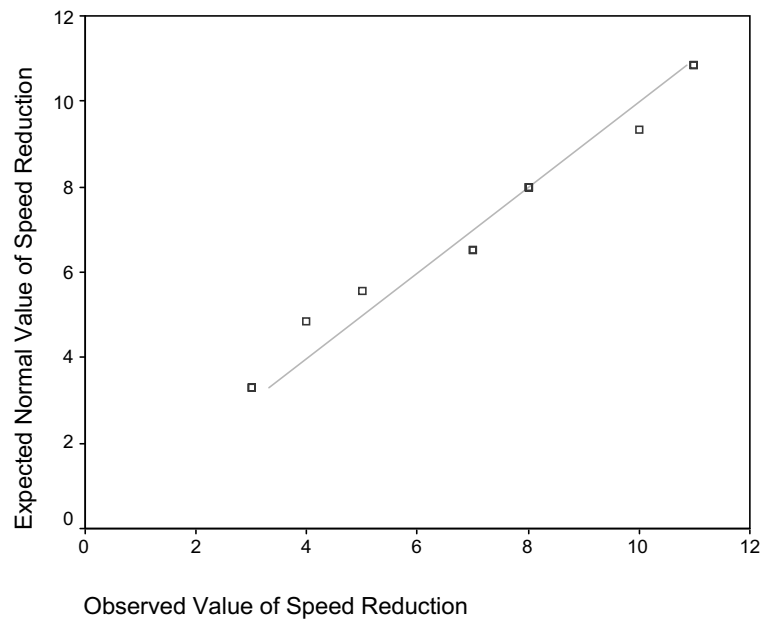

Figure 3.41 Quantile-Normal Plot of Speed Reduction in Which the Headway Was Greater Than 0.1 Minute and Warning System Was Not Active (“Before” Case)

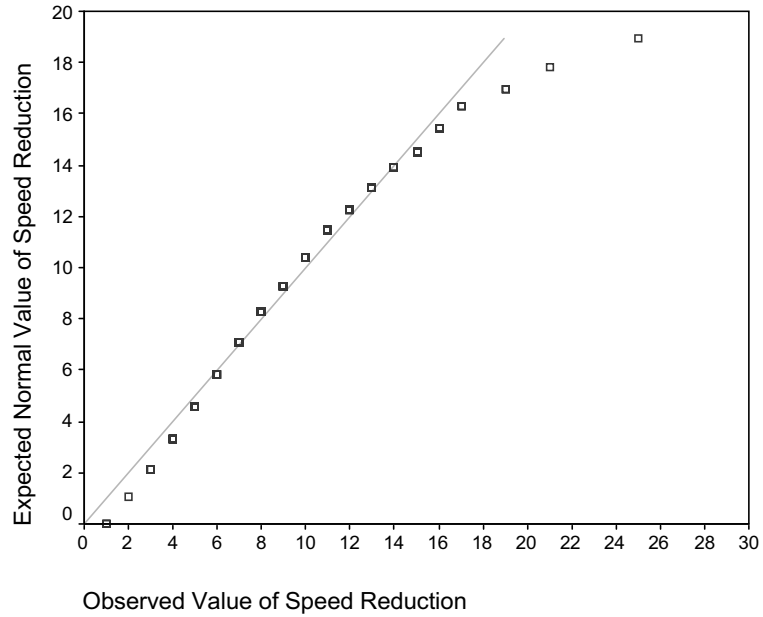

Figure 3.42 Quantile-Normal Plot of Speed Reduction in Which the Headway Was Greater Than 0.1 Minute and Warning System Was Active (“After” Case)

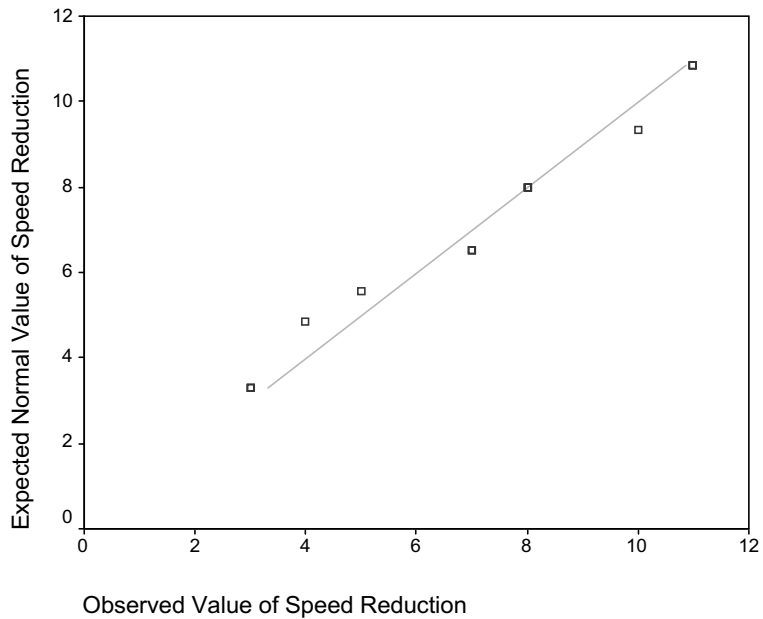

Figure 3.43 Quantile-Normal Plot of Speed Reduction in Which the Headway Was Less Than or Equal to 0.1 Minute and Warning System Was Not Active (“Before” Case)

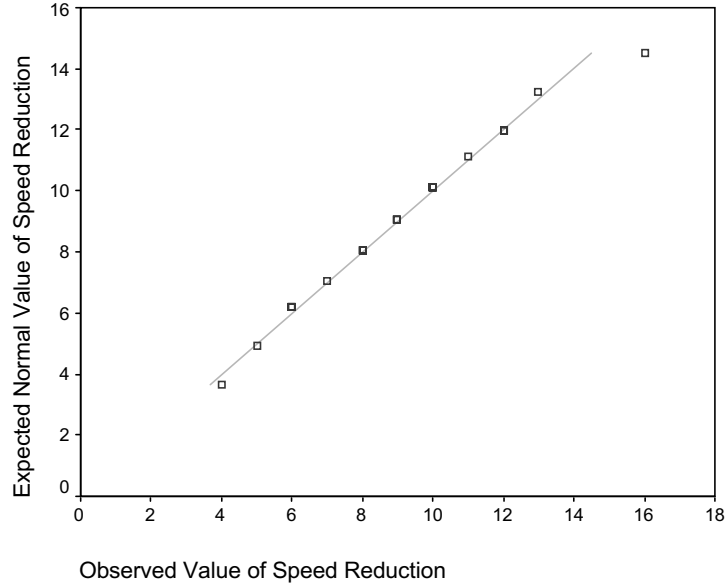

Figure 3.44 Quantile-Normal Plot of Speed Reduction in Which the Headway Was Less Than or Equal to 0.1 Minute and Warning System Was Active (“After” Case)

The hypotheses are stated as

$H_0 : \Delta S_a - \Delta S_b = 0$  Average speed reduction of violating trucks without (“before” case) and with (“after” case) warning flashers is the same.

$H_1 : \Delta S_a - \Delta S_b > 0$  The average speed reduction of violating trucks is greater with (“after” case) warning flashers.

Where:  $\Delta S_a$  is the speed reduction of violating trucks with warning flashers, and  $\Delta S_b$  is the speed reduction of violating trucks without warning flashers.

Statistical values for the stratified speed reduction data sets in different headway groups are calculated by applying Eq 3.1 and 3.2.

1. Headway greater than 0.1 minute

$$T = \frac{9 - 7}{\sqrt{\frac{3.16^2}{129} + \frac{3.48^2}{255}}} = 5.66 \quad (\text{Eq 3.7})$$

$$v = 280 \quad (\text{Eq 3.8})$$



The critical  $T$  score corresponding to the significance level of 99 percent is 2.576. As the observed  $T$  score, 5.66, is greater than the critical  $T$  score, the warning system can be said to have produced statistically significant speed reduction for the high, long, fast vehicles having greater than 0.1-minute headway with more than 99 percent confidence.

2. Headway less than or equal to 0.1 minute

$$T = \frac{9 - 7}{\sqrt{\frac{2.84^2}{12} + \frac{2.78^2}{24}}} = 2 \quad (\text{Eq 3.9})$$

$$v = 22 \quad (\text{Eq 3.10})$$

The critical  $T$  value at the 95 percent significance level is 2.074, and the  $T$  value at the 90 percent significance level is 1.717. As the observed  $T$  score, 2, is between 1.717 and 2.074, the warning system again can be said, with greater than 90 percent but less than 95 percent confidence, to have produced statistically significant speed reductions of high, long, fast vehicles having less than or equal to 0.1-minute headway.

### 3.2.5 Summary

The Before-and-After case studies of speed change of violating trucks, (i.e., those detected by the TDA3 system that were at least 16 ft (4.9 m) long at a height of 7 ft (2.1 m) above the road surface, and traveling at or above a speed of 56 mi/h (90 km/h) on the straight, tapered section of the ramp terminal soon after exiting the main lanes of I-610 and some 950 ft (290 m) in advance of the curved portion of the ramp proper), indicated that all such trucks decreased speed as they approached the curve. However, those observed during the “after” study, when flashers (hazard identification beacons) were activated by the TDA3 system only for violating trucks approaching the curve, decreased speed, on average, more than those sampled in the “before” study, without flashers.

After the observed speed-reduction data sets were stratified according to speed ranges and headway groups, the following findings resulted from the analysis.

1. On average, violating trucks in the higher initial speed range, 62 to 70 mi/h (100 to 113 km/h), reduced speed more — by 8 to 10 mi/h (13 to 16 km/h) — than did those in the lower speed range, 56 to 62 mi/h (90 to 100 km/h) — 6 to 8 mi/h (10 to 13 km/h) — under both the “before” and “after” operating conditions.
2. The additional average speed reduction for all violating trucks attributable to the effect of the flashers being activated by the TDA3 system in the “after” case study was 2 mi/h (3 km/h). This magnitude of speed reduction was statistically significant at the 99 percent confidence level. That is, in the “after” study, this much additional speed reduction would be expected to occur owing to chance alone only 1 time in 100 observations.
3. When speed-reduction data were grouped according to time headway between pairs of violating trucks, the trucks operating at a headway greater than 0.1 minute (6 seconds) were observed to respond to the warning flashers by reducing speed, on average, an additional 2 mi/h (3 km/h) more than those observed when the flashers were not activated. This value was statistically significant at the 99 percent confidence level.
4. The drivers of trucks operating at a headway equal to or less than 0.1 minute (6 seconds), also responded to the warning flashers by reducing speed, on average, an additional 2 mi/h (3 km/h) more than when the flashers were not activated. However, the statistical confidence with which this much additional speed reduction would be expected to occur was only 90 percent to 95 percent. At these shorter headways, the speed of the vehicle ahead affects the speed of the vehicle behind, and the choice of speed by each following driver is not independent.

## CHAPTER 4. CONCLUSION AND RECOMMENDATIONS

### 4.1 CONCLUSION

This research was undertaken to develop an instrument system that could reliably detect high, long, fast trucks on freeway-to-freeway interchange ramps and activate displays to warn their drivers of roadway geometry ahead that might warrant a speed reduction in order to avoid hazardous operating conditions. Such a system was developed and installed for evaluation on the elevated directional interchange ramp that carries southbound traffic on I-610 turning eastbound onto SH 225 in Houston, Texas. The system was installed in January 1997 and was used to monitor traffic successfully at the site for more than 2 years with only three major failures: once a vehicle backing along the ramp shoulder hit a sensor behind the bridge rail and knocked it out of alignment, and twice lightning (apparently) struck the area and burned several electronic components in the microcontroller unit and the modem. Data were downloaded via modem routinely to the Center for Transportation Research (CTR) lab in Austin at midnight every 2 days. Characteristic traffic patterns on the ramp are discussed in Chapter 2.

The criteria chosen to identify candidate trucks for activating a series of hazard identification beacons (flashers) to supplement an array of standard and experimental warning signs and advisory speed plates were: those trucks that were at least 16 ft (4.9 m) long at a height of 7 ft (2.1 m) above the road surface and were traveling at or above a speed of 56 mi/h (90 km/h) on the straight, tapered section of the exit ramp terminal. Any truck that exceeded these criteria was called a violating truck.

After evaluating the historical pattern of traffic volume and speed at the site, a Before-and-After speed-change study was scheduled and conducted on two selected weekdays when large numbers of violating trucks had been observed consistently. In the “before” study (Tuesday, January 26, 1999 - the flashers were not activated, but in the “after” study (Wednesday, February 17, 1999; the warning flashers had been enabled since Wednesday, January 27, 1999), the warning system activated the flashers only for violating trucks. Speed was measured at two locations 790 ft (240 m) apart on the ramp in advance of

the curved section using a pair of infrared light-beam sensors placed just above the road surface to detect the passage of the vehicles' tires, the most accurate way to measure speed with the reflex-type infrared light-beam sensors. Speed measurements were within 1 mi/h (2 km/h). The speed difference between these locations (always a speed reduction) was calculated for 141 violating trucks in the "before" case and for 280 in the "after" case.

Analysis of the before-and-after case study data sets revealed the following findings.

1. On average, violating trucks in the higher initial speed range, 62 to 70 mi/h (100 to 113 km/h), reduced speed more — by 8 to 10 mi/h (13 to 16 km/h) — than did those in the lower speed range, 56 to 62 mi/h (90 to 100 km/h) — 6 to 8 mi/h (10 to 13 km/h) — under both the "before" and "after" operating conditions.
2. The additional average speed reduction for all violating trucks attributable to the effect of the flashers being activated by the TDA3 system in the "after" case study was 2 mi/h (3 km/h). This magnitude of speed reduction was statistically significant at the 99 percent confidence level. That is, in the "after" study, this much additional speed reduction would be expected to occur owing to chance alone only 1 time in 100 observations.
3. Trucks operating at a headway greater than 0.1 minute (6 seconds) were observed to respond to the warning flashers by reducing speed, on average, an additional 2 mi/h (3 km/h) more than when the flashers were not activated. This value was statistically significant at the 99 percent confidence level.
4. Those trucks operating at a headway equal to or less than 0.1 minute (6 seconds) also responded to the warning flashers by reducing speed, on average, an additional 2 mi/h (3 km/h) than was the case when the flashers were not activated, but the statistical confidence with which this much additional speed reduction would be expected to occur was only 90 percent to 95 percent.

The portion of Project 7-2915 that was intended to evaluate the potential additional safety benefits of using the capabilities of the Amtech Intelligent-Tag-On-Vehicle system met with only partial success. The basic Amtech instruments were adapted operationally to

send a signal from the roadside antenna to the on-vehicle tag only when the warning criteria described above were exceeded. The TDA3 system initiated the trigger signal to the Amtech system at the same time as it activated the flashers. When the signal from the Amtech antenna was received by the tag mounted in the truck cab, a small light on the tag was illuminated and a faint sound was emitted momentarily. Tags carried in test vehicles confirmed the proper operation of the system over the full range of speed in both lanes of travel observed on the ramp, but the visual and audio tag emissions were very difficult to detect, even in a passenger van. Only fifty tags were distributed to five different trucking companies. In the 14 hours during which speed measurements were made in February 1999, only six tag-equipped violating trucks were detected. This sample size is far too small to provide useful statistical data.

#### **4.2 RECOMMENDATIONS**

Based on the experiences described above, the following recommendations are made to potentially improve the effectiveness of the truck monitoring and warning system for application on freeway-to-freeway interchange ramps.

1. Use more and larger-diameter flashers.

The hazard identification beacons (flashers) used in the study comprised pairs of 8 in. (0.2 m) diameter circular yellow lenses, illuminated simultaneously and intermittently, and displayed above and below a warning sign at three locations along the right-hand side of the ramp (see Chapter 2). In the spatial expanse visible to drivers using the 2-lane, high-speed, elevated ramp, the flashers had little visual impact. To increase the visibility of the flashers, and thus their attention value, it is recommended that the flasher/sign array be placed on both sides of the ramp at each location and that 12 in. (0.3 m) diameter circular yellow lenses be used. The illumination sequence should alternate between the top and bottom lens units to create a sensation of movement. Tests have shown that movement improves visibility of warning signals and response time (Ref 17).

2. Raise value of speed criterion.

From the data shown in Table 3.3, it was found that about 70 percent of all trucks using the ramp would trigger the warning system when the speed criterion was set to 56 mi/h (90 km/h). This percentage seems excessive. If the speed criterion value were set to 60 mi/h (96 km/h), only about 43 percent of the trucks would set off the warning system (see Table 4.1). Moreover, if the speed criterion were set at 65 mi/h (105 km/h), only about 13 percent of the trucks would be picked up by the warning system (see Table 4.2). As the posted speed limit on the main lanes of I-610 has been raised to 60 mi/h (96 km/h), it might be more effective to set the warning speed criterion to 65 mi/h (105 km/h) and actuate the flashers for only about 13 percent of the long, high, fast ramp trucks.

Table 4.1 Ratio of Trucks with Speed More Than or Equal to 60 mi/h (96 km/h) to Total Trucks on Weekdays

<b>Day</b>	<b>Number of Trucks</b>	<b>Ratio of Trucks with Speed More Than or Equal to 60 mi/h to Total Trucks (%)</b>
Monday	3,022	47
Tuesday	3,109	43
Wednesday	3,202	43
Thursday	3,124	34
Friday	3,134	35
Saturday	982	55
Sunday	707	52

Table 4.2 Ratio of Trucks with Speed More Than or Equal to 65 mi/h (104 km/h) to Total Trucks on Weekdays

<b>Day</b>	<b>Number of Trucks</b>	<b>Ratio of Trucks with Speed More Than or Equal to 65 mi/h to Total Trucks (%)</b>
Monday	3,022	16
Tuesday	3,109	15
Wednesday	3,202	13
Thursday	3,124	10
Friday	3,134	11
Saturday	982	25
Sunday	707	24

3. Increase the intensity of the visual and audio signals on the Amtech tags.

If the additional warning intelligence that can be provided inside the vehicle to the truck driver by the Amtech tag in the noisy truck cab is to be realized, the intensity of the visual and audio signals on the Amtech tags must be increased significantly. Additional field studies will be needed to evaluate the relative effectiveness of this information.





## BIBLIOGRAPHY

1. Winkler, C. P., P. Fancher, and C. MacAdam. *Parametric Analysis of Heavy Duty Truck Dynamic Stability*, Volume I, Technical Report. University of Michigan Transportation Research Institute, Ann Arbor, MI, 1983.
2. Home, W. "Predicting the Minimum Dynamic Hydroplaning Speed for Aircraft, Bus, Truck, and Automobile Tires Rolling on Flooded Pavements." Presented to ASTM Committee E-17, Texas Transportation Institute, Texas A&M University System, College Station, TX, June 5, 1984.
3. Ivey, D. *Tractor-Semitrailer Accidents in Wet Weather*. Texas Transportation Institute, Texas A&M University System, College Station, TX, May 1985.
4. Vallete, G., H. McGee, J. Sanders, and D. Enger. *The Effect of Truck Size and Weight on Accident Experience and Traffic Operations*. FHWA/RD-80/137, Federal Highway Administration, Washington, D.C., July 1981.
5. Middleton, D. *A Study of Selected Warning Devices for Reducing Truck Speeds*. FHWA/TX-95/1232-28, Texas Transportation Institute, Texas A&M University System, Research Report 1232-28, November 1994.
6. Firestine, M., H. McGee, and P. Toeg. *Improving Truck Safety at Interchanges*, FHWA-IP-89-024. Federal Highway Administration Office of Implementation, McLean, VA, September 1989.
7. Firestine, M., W. Hughes, and N. Natelson. *Operating Larger Trucks on Roads with Restrictive Geometry: Summary Report*, FHWA-IP-89-025. Federal Highway Administration Office of Implementation, McLean, VA, September 1989.
8. *A Policy on Geometric Design of Highways and Streets*, American Association of State Highway and Transportation Officials, Washington, D.C., 1994.
9. Walpole, Ronald E., and Raymond H. Myers. *Probability and Statistics for Engineers and Scientists*, MacMillan Publishing Company, New York, 1989.
10. Rob, Peter, and Carlos Coronel. *Database Systems Design, Implementation, and Management*, ISBN: 0-7600-4904-1. International Thomson Publishing Company, Cambridge, MA, 1997.
11. Kennedy, Dennis, Joe Garrick, Bill Harper, and Jason T. Roff. *Visual Basic 5 Database How-To*, ISBN 1-57169-104-9. Waite Group Press, a Division of MacMillan Computer Publishing, Corte Madera, CA, 1997.
12. *Manual on Uniform Traffic Control Devices for Streets and Highways*. U.S. Department of Transportation, Federal Highway Administration, U.S. Government Printing Office, Washington, D.C., 1978

13. Chrest, Anthony P., Mary S. Smith, and Sam Bhuyan. *Parking Structures Planning, Design, Construction, Maintenance, and Repair*, ISBN: 0-442-20655-0. Van Nostrand Reinhold, New York, 1989.
14. Hamilton, Lawrence C. *Regression with Graphics, a Second Course in Applied Statistics*, Wadsworth, Inc., Belmont, CA, 1992.
16. Amtech Web Site <http://www.amtech.com/hightech/index.htm>.
17. *SPSS for Windows*, Release 8.0.0, Copyright SPSS Inc., 1989–1997.
18. Cohn, Theodore E. “Objects in Mirror are Closer than They Appear,” *ACCESS*, Research at the University of California Transportation Center, No. 14, Spring 1999.

## APPENDIX. OPERATION MANUAL OF TDA3 SYSTEM

The TDA3 application program is used to control the TDA3 hardware. It consists of several forms. The user can easily operate the TDA3 system through this application program. The section below will introduce every form in this application.

### 1. Title Form

The title form will describe the information about title, designer, version, etc. Simply press any key to go to the next page (see Figure A.1).

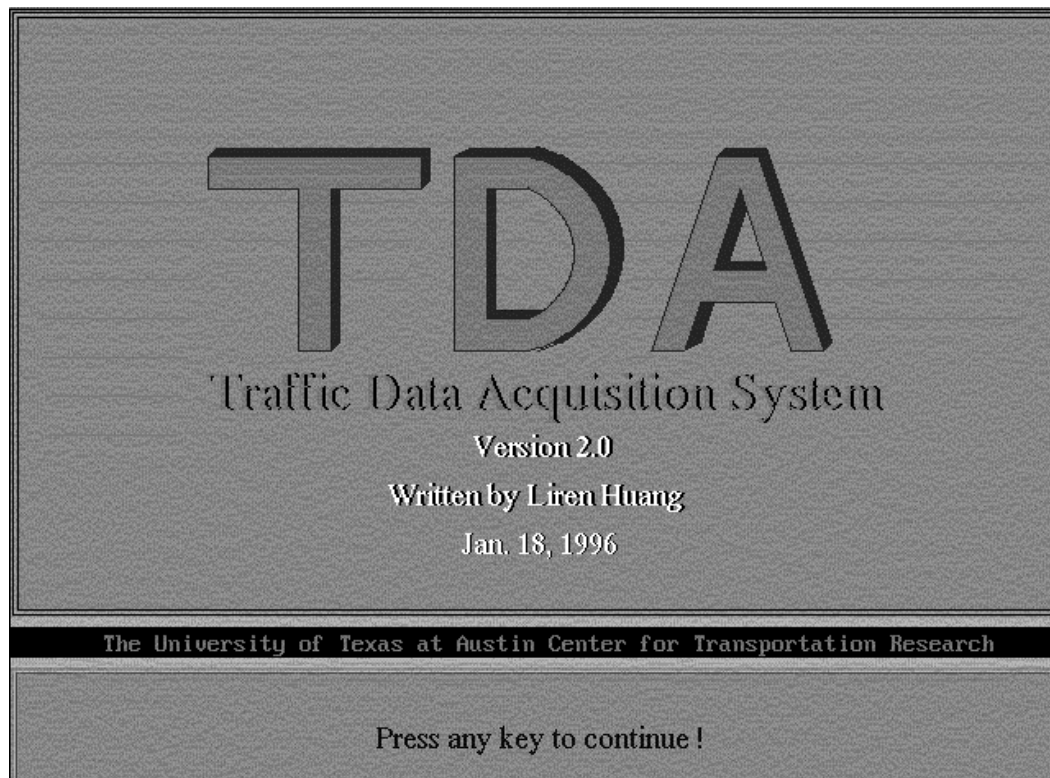

Figure A.1 TDA3 Title Form

## 2. Password Form

This form is used to input a password (see Figure A.2).

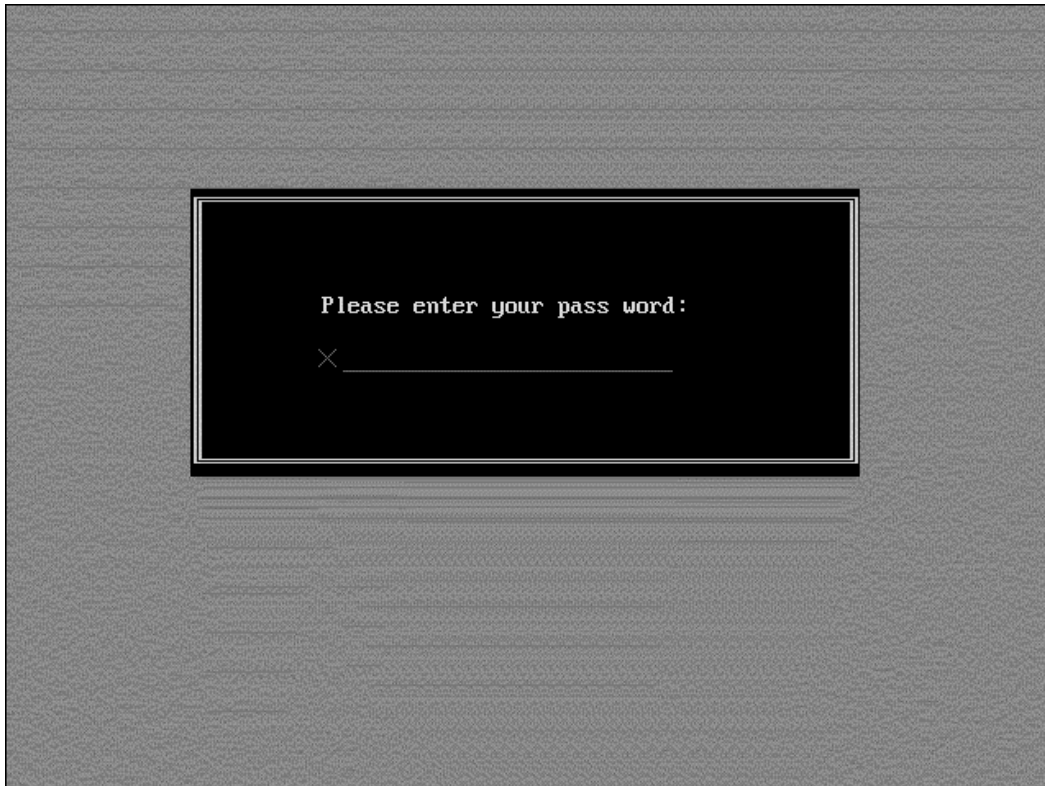

Figure A.2 Password Form of TDA3

## 3. Choose Connection Mode Form

There are four options in this form (see Figure A.3).

### 1) Direct mode

Use when TDA3 board is directly connected to a local PC. Click on this option to show the form on the monitor.

### 2) Remote mode

This mode will be selected when the TDA3 board is connected to a remote PC through a modem. This option lets the application go to the map form.

3) Auto Download

Simply click this option and follow the instructions to set parameters; the program will then automatically download data from a remote site at 12:00:00 (midnight) every day.

4) Quit

Quit program.

After the user chooses Direct or Remote mode, the program will first check the communication port, then go to the next step (see Figure A.4).

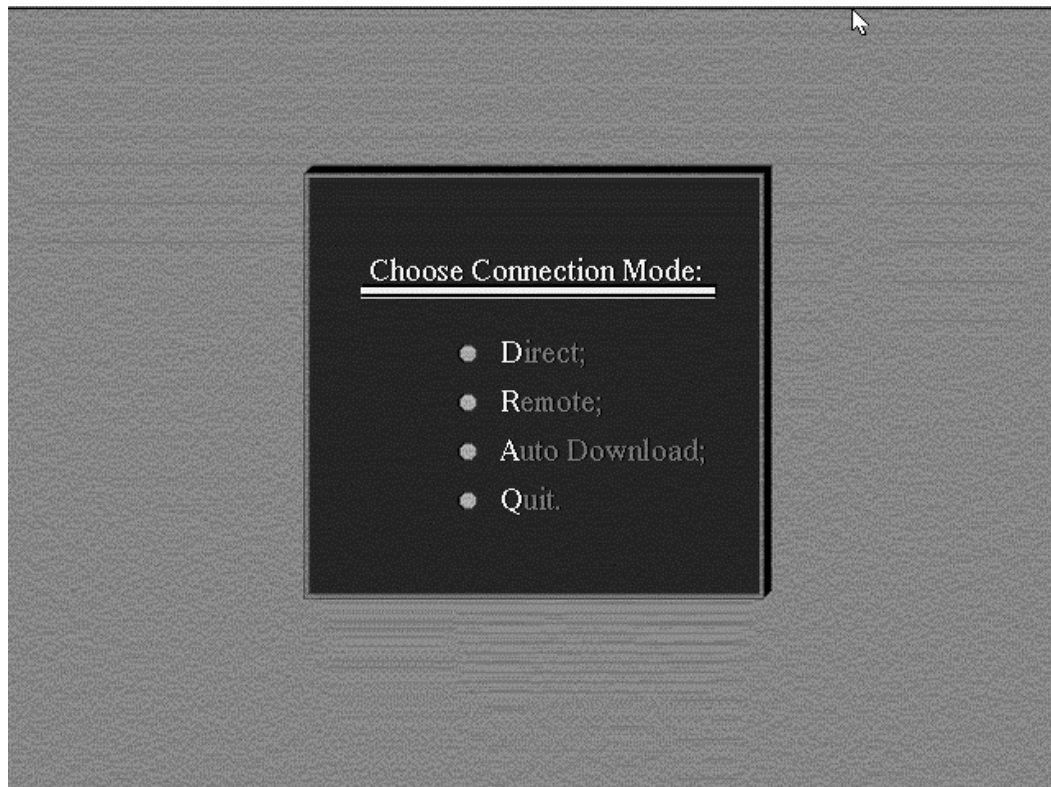

Figure A.3 Choose Connection Mode Form of TDA3



Figure A.4 Check Form of TDA3

#### 4. Map Form

After the remote mode has been selected, the map form will show. User can confirm head-code and telephone number and enter monitor form by clicking Houston on the map (see Figure A.5).

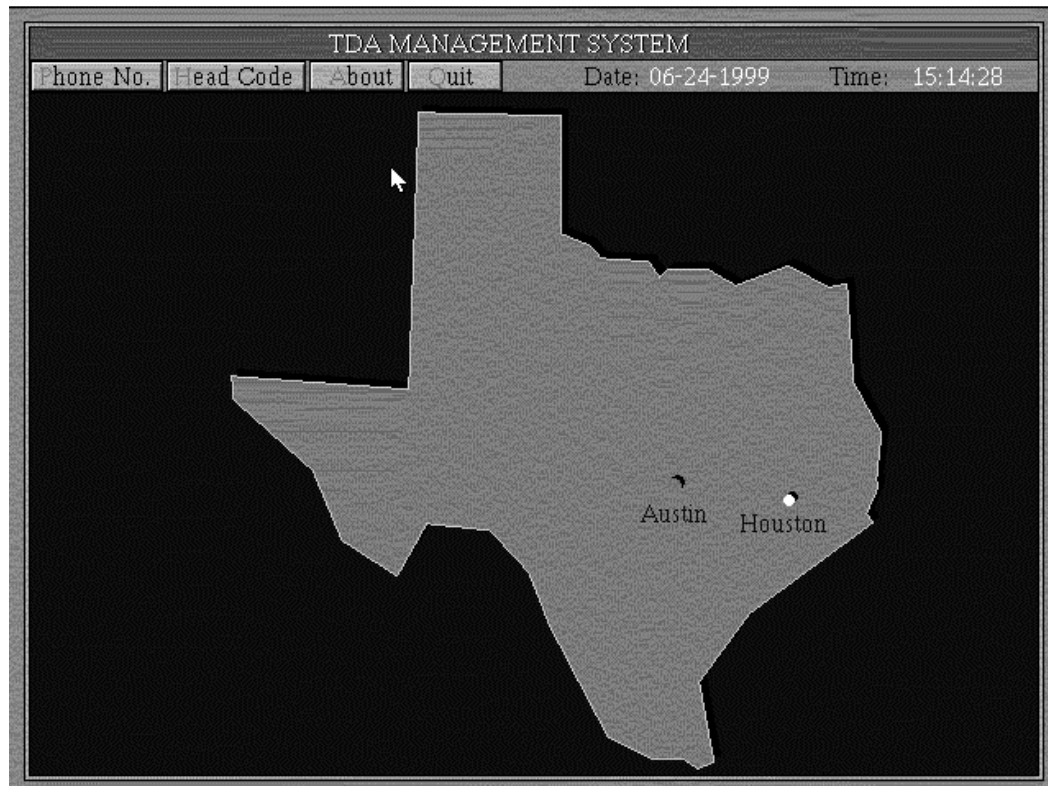

Figure A.5 Map Form of TDA3

## 5. Monitor Form

The user can reset the critical parameters of the TDA system through clicking the Setup button, monitor the violating truck, the distribution of hourly traffic volume, and the traffic speed through clicking the Monitor button and closing the form through clicking the Close button (see Figures A.6 and A.7).

**Notice:** If the user clicks the Setup button to reset the system, all data in the system memory will be lost. The About button is used to check the information about the program designer. The Parameter button is used to set the timer parameter that is a constant, 3,599. The user clicks TDA Time button to determine whether the system time is equal to real time. If not, the user may need to click the Parameter button to check to see if the timer parameter is 3,599.



Figure A.6 Monitor Form of TDA3 Before Click Monitor Button

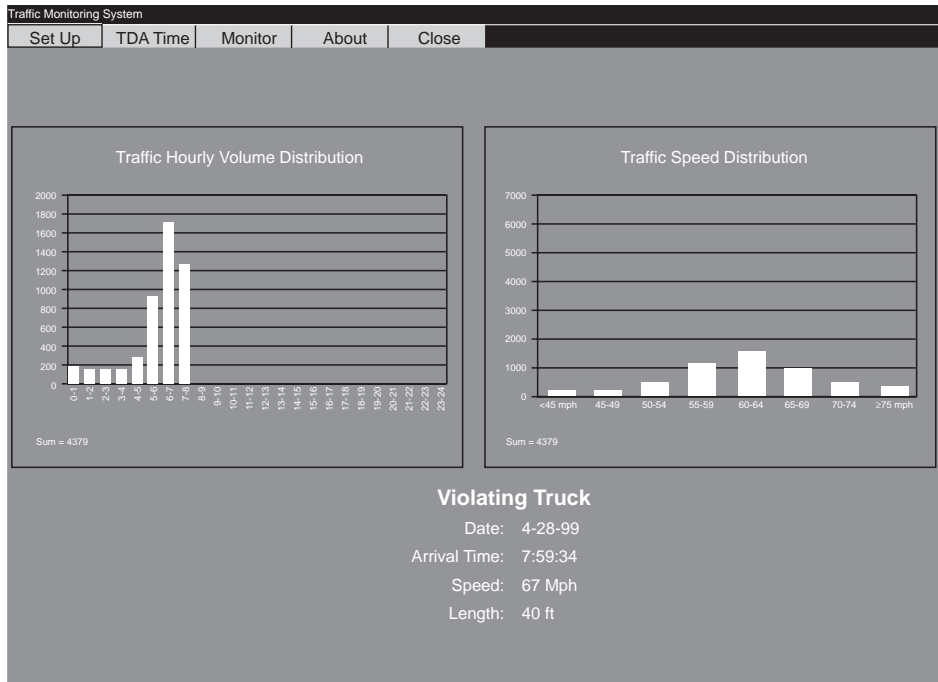
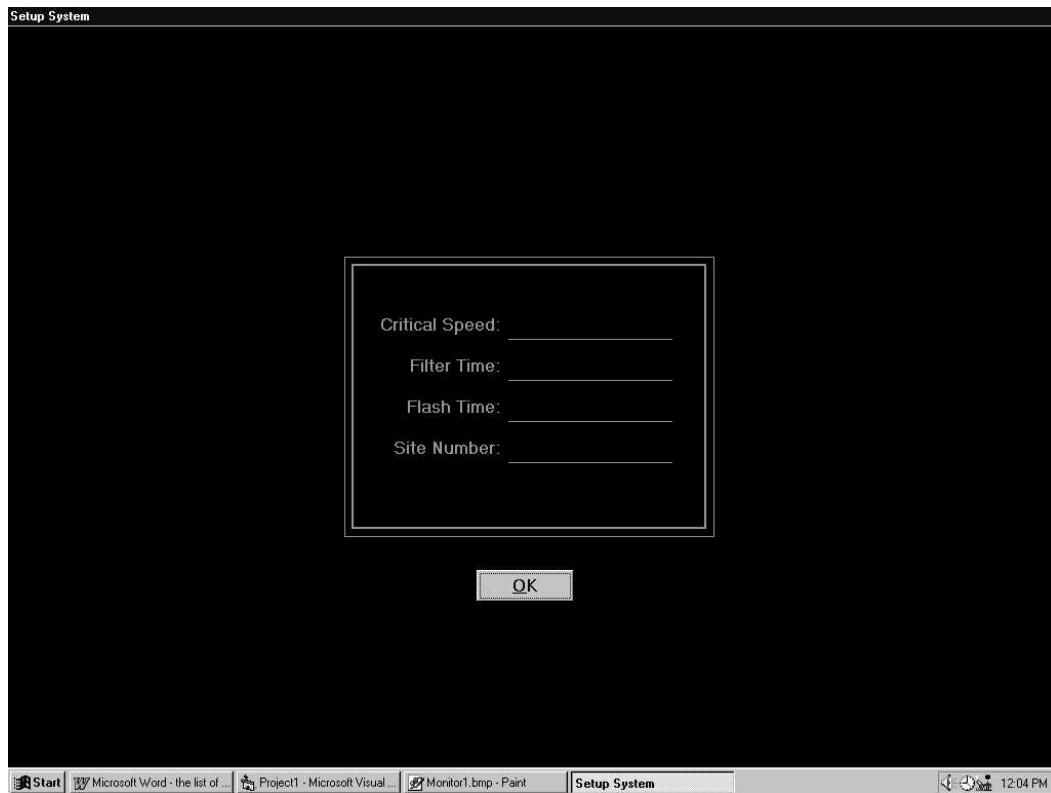

Figure A.7 Monitor Form of TDA3 After Click Monitor Button



## 6. Setup Form

In the setup form, the user needs only to type in all parameters and then click OK to reset the system (see Figure A.8).



The image shows a screenshot of a Windows desktop environment. The active window is titled "Setup System". The window's background is black. In the center, there is a white-bordered rectangular area containing four text labels, each followed by a horizontal input line: "Critical Speed:", "Filter Time:", "Flash Time:", and "Site Number:". Below this area is a single "OK" button. The Windows taskbar at the bottom shows the Start button, several open application windows (Microsoft Word, Microsoft Visual Studio, Paint), and the system tray with the time "12:04 PM".

Figure A.8 Setup Form of TDA3

