

March 1982  
NHTSA Technical Report

DOT HS-806-191



U.S. Department  
of Transportation  
**National Highway  
Traffic Safety  
Administration**

# **Model Performance Specifications for Police Traffic Radar Devices**

---

Traffic Safety Programs  
Enforcement & Emergency Services

1. Report No. DOT HS 806 191	2. Government Accession No.	3. Recipient's Catalog No.	
4. Title and Subtitle Model Performance Specifications for Police Traffic Radar Devices		5. Report Date March, 1982	
		6. Performing Organization Code	
7. Author(s) National Highway Traffic Safety Administration		8. Performing Organization Report No.	
9. Performing Organization Name and Address National Highway Traffic Safety Administration U. S. Department of Transportation Washington, DC 20590		10. Work Unit No. (TRAIS)	
		11. Contract or Grant No. See # 15	
12. Sponsoring Agency Name and Address National Highway Traffic Safety Administration U. S. Department of Transportation Washington, DC 20590		13. Type of Report and Period Covered  Oct., 1977 - March, 1982	
		14. Sponsoring Agency Code	
15. Supplementary Notes The model specifications described in Chapter 3 of this report were prepared by the Law Enforcement Standards Laboratory of the National Bureau of Standards (NBS) under Interagency Agreement # DOT-HS-7-01697 between NBS and NHTSA.			
16. Abstract This report provides information about all of the research work regarding police traffic radar completed by the National Bureau of Standards (NBS) under an Inter-Agency Agreement with the National Highway Traffic Safety Administration (NHTSA).  <u>Chapter 1</u> provides an overview of the current status of police traffic radar for speed enforcement. It summarizes the Federal government's activity in this area since 1977 and reiterates NHTSA's recommendations regarding the future use of radar for speed enforcement.  <u>Chapter 2</u> discusses the recent proposed rulemaking activity for performance standards for police traffic radar as they were published in the Federal Register (46 FR 2097). However, the Agency has decided to terminate the rulemaking process. In place of a performance standard, model performance specifications are being published. The rationale for changes the Agency has made in the proposed performance standards before they are being released in the form of model performance specifications are included in this chapter.  <u>Chapter 3</u> presents the actual model specifications for police traffic radar, along with recommended procedures whereby radar devices can be tested to assess whether they meet the proposed guidelines.			
17. Key Words model specifications radar police speed enforcement radar devices police traffic radar speed enforcement speed measuring devices		18. Distribution Statement This document is available to the public through the National Technical Information Service, Springfield, Virginia 22161	
19. Security Classif. (of this report) Unclassified	20. Security Classif. (of this page) Unclassified	21. No. of Pages	22. Price

## METRIC CONVERSION FACTORS

### Approximate Conversions to Metric Measures

Symbol	When You Know	Multiply by	To Find	Symbol
<b>LENGTH</b>				
in	inches	2.5	centimeters	cm
ft	feet	30	centimeters	cm
yd	yards	0.9	meters	m
mi	miles	1.6	kilometers	km
<b>AREA</b>				
in <sup>2</sup>	square inches	6.5	square centimeters	cm <sup>2</sup>
ft <sup>2</sup>	square feet	0.09	square meters	m <sup>2</sup>
yd <sup>2</sup>	square yards	0.8	square meters	m <sup>2</sup>
mi <sup>2</sup>	square miles	2.6	square kilometers	km <sup>2</sup>
	acres	0.4	hectares	ha
<b>MASS (weight)</b>				
oz	ounces	28	grams	g
lb	pounds	0.45	kilograms	kg
	short tons (2000 lb)	0.9	tonnes	t
<b>VOLUME</b>				
1/2sp	teaspoons	5	milliliters	ml
1bsp	tablespoons	15	milliliters	ml
fl oz	fluid ounces	30	milliliters	ml
c	cups	0.24	liters	l
pt	pints	0.47	liters	l
qt	quarts	0.96	liters	l
gal	gallons	3.8	liters	l
ft <sup>3</sup>	cubic feet	0.03	cubic meters	m <sup>3</sup>
yd <sup>3</sup>	cubic yards	0.76	cubic meters	m <sup>3</sup>
<b>TEMPERATURE (exact)</b>				
°F	Fahrenheit temperature	5/9 (after subtracting 32)	Celsius temperature	°C



### Approximate Conversions from Metric Measures

Symbol	When You Know	Multiply by	To Find	Symbol
<b>LENGTH</b>				
mm	millimeters	0.04	inches	in
cm	centimeters	0.4	inches	in
m	meters	3.3	feet	ft
m	meters	1.1	yards	yd
km	kilometers	0.6	miles	mi
<b>AREA</b>				
cm <sup>2</sup>	square centimeters	0.16	square inches	in <sup>2</sup>
m <sup>2</sup>	square meters	1.2	square yards	yd <sup>2</sup>
km <sup>2</sup>	square kilometers	0.4	square miles	mi <sup>2</sup>
ha	hectares (10,000 m <sup>2</sup> )	2.5	acres	
<b>MASS (weight)</b>				
g	grams	0.035	ounces	oz
kg	kilograms	2.2	pounds	lb
t	tonnes (1000 kg)	1.1	short tons	
<b>VOLUME</b>				
ml	milliliters	0.03	fluid ounces	fl oz
l	liters	2.1	pints	pt
l	liters	1.06	quarts	qt
l	liters	0.26	gallons	gal
m <sup>3</sup>	cubic meters	35	cubic feet	ft <sup>3</sup>
m <sup>3</sup>	cubic meters	1.3	cubic yards	yd <sup>3</sup>
<b>TEMPERATURE (exact)</b>				
°C	Celsius temperature	9/5 (then add 32)	Fahrenheit temperature	°F

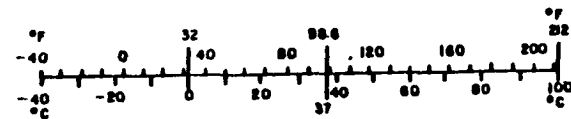

\*1 in = 2.54 (exactly). For other exact conversions and more detailed tables, see NBS Misc. Publ. 286, Units of Weights and Measures, Price \$2.25, SD Catalog No. C13.10-286.

TABLE OF CONTENTS

	<u>Page</u>
Preface . . . . .	.1
Chapter 1 - Overview . . . . .	3
Chapter 2 - Discussion About the Model Performance Specifications . . . . .	9
Chapter 3 - Model Performance Specifications for Police Traffic Radar Devices . . . . .	.16
Appendix A . . . . .	.87
Appendix B . . . . .	.96

## PREFACE

This document has been prepared for a number of audiences interested in police traffic radar. They include police agencies that use radar equipment to enforce speed laws, the legal community that depends on the accuracy and reliability of radar evidence to support speeding citations, and the radar manufacturers. The report provides the reader with information about all of the research work regarding police traffic radar completed by the National Bureau of Standards (NBS) under an interagency agreement with the National Highway Traffic Safety Administration (NHTSA).

There are three chapters in this report. The first chapter provides an overview of the current status of police traffic radar for speed enforcement. It summarizes the Federal Government's activity in this area since 1977 and reiterates NHTSA's recommendations regarding the future use of radar for speed enforcement. (See the NHTSA position paper entitled "Police Traffic Radar," published in 1980 as a NHTSA Technical Report No. DOT-HS-805-254 for a more complete presentation of this material.)

The second chapter discusses the recent proposed rulemaking activity for performance standards for police traffic radar as they were published in the Federal Register (46 FR 2097). However, the Agency has decided to terminate the rulemaking process. In place of a performance standard, model performance specifications are being published in the next chapter of this document. The rationale for changes the Agency has made in the proposed performance standards before they are being released in the form of model performance specifications are included in this chapter.

Chapter 3 presents the actual model specifications for police traffic radar, along with recommended procedures whereby radar devices can be tested to assess whether they meet the proposed guidelines.

Finally, Appendix A provides the reader with a model "Request for Proposals" (RFP) for traffic radar prepared by the Michigan State Radar Commission. We endorse the format suggested in this model RFP and would encourage other States and local jurisdictions to consider using it when procuring police radar equipment. Of course, we recognize that many State and local jurisdictions may have unique requirements and would need to modify such an RFP to meet their needs.

Appendix B reprints the text of our recent report describing field strengths of 20 models of radar units. A copy of the complete report is available upon request. ("Field Strength Measurements of Speed Measuring Radar Units," (1981), NHTSA Technical Report No. DOT-HS-805-928.)

CHAPTER 1--OVERVIEW

Police traffic radar has been used to detect speeding motorists for about 30 years in this country. During that time radar speed measuring devices have evolved from the original bulky stationary models to the present compact and sophisticated models capable of monitoring vehicle speeds in both stationary and moving modes. These technological advances have greatly enhanced the mobility, efficiency, and effectiveness of police traffic radar operations. However, highway safety and traffic law enforcement officials are now faced with a dilemma since the same technological advances that enable increased productivity and efficiency have also witnessed closer scrutiny by the courts. In addition, the public is beginning to question both the reliability and accuracy of radar devices and the adequacy of police radar operator training.

At the present time, there are no nationally recognized performance standards for police traffic radar speed measuring devices. Further, operator training requirements, which have traditionally been established by each individual police agency (usually with the assistance of the radar manufacturer), range from less than one hour to several days. The quality of operator training often has not kept up with the technological advances. In many cases, training has been limited to teaching the officer how to set up, test, and operate the device. All too often, failure to provide detailed training in recognizing and avoiding the electronic anomalies associated with modern traffic radar devices has led police officers to believe that radar devices are infallible.

A highly publicized Dade County, Florida evidentiary hearing regarding the reliability and accuracy of radar illustrates the type of challenge now being encountered. The hearing, conducted by Judge Alfred Nesbitt in April 1979, focused on two issues. First, whether radar speed measuring devices currently produced are reliable enough to be used as evidence; and second, whether police officers are receiving adequate training in the proper operation of the devices. After nine days of testimony, during which experts from both sides were invited to testify, Judge Nesbitt ruled:

... that the reliability of the radar speed measuring devices as used in their present modes and particularly in these cases, has not been established beyond and to the exclusion of every reasonable doubt ... .

While the Dade County hearing did not trigger the predicted nationwide demise of police traffic radar, it has highlighted the fact that there are circumstances where radar has its limitations. Subsequent court decisions such as State of New Jersey vs. Wojtkowiak and State of Hawaii vs. Earl W. Fedje, et al., generally have upheld the reliability and accuracy of police traffic radar. However, the message from the courts is clear: highway safety and law enforcement administrators must ensure that radar operators receive adequate training, including recognition and avoidance of the electronic anomalies associated with such devices. Operators must be able to demonstrate their competence with the unit under varying conditions in supervised field performance tests. In addition, the radar manufacturing industry should implement strict quality control measures to ensure the reliability and accuracy of their equipment, and continue to search for ways to improve the target identification capabilities of present radar devices.

The courts, as well as some radar critics, also have pointed out the need for State-level policy guidance for police radar enforcement programs. The immediate reaction to such criticism tends to be defensive. Perhaps this is an appropriate time to review radar programs from a constructive viewpoint. After evaluation of present programs, highway safety and law enforcement officials should develop and implement comprehensive policies and procedures to ensure that police traffic radar is used properly and that traffic safety and energy conservation goals are achieved. State-level policy guidance would provide the added benefit of increased uniformity within a State and encourage statewide development of standard operating procedures. This would enhance voluntary compliance as the motorist travels through the many jurisdictions within each State.

NHTSA has sponsored two programs which should upgrade both the reliability and credibility of police traffic radar equipment and the quality of operator training.

### Equipment:

In August 1977, before the above issues were raised publicly, NHTSA entered into an interagency agreement with NBS to develop performance standards for police speed measuring devices. The NBS has inventoried all police speed measuring devices (radar and nonradar) used in this country and has developed or is developing comprehensive performance specifications for each speed measuring device category. The draft performance standards for radar devices were completed and submitted to NHTSA in November 1980. On January 8, 1981, these specifications appeared as a proposed rulemaking in the Federal Register 23 CFR 1221. Nineteen comments were received and reviewed in response to the proposed rule. The comments that were appropriate were synthesized into the model radar specifications which are presented later in this report. It is hoped that these model specifications will assist police administrators in making more informed purchasing decisions.

In addition, we asked NBS to conduct special performance tests on the six radar devices identified in the Dade County hearing. The purpose of this project was to test each of the six radar units to observe their operational capability in certain operating situations or environments that were described in the hearing. The preliminary test results confirmed that the six devices produced reliable and accurate speed measurements. However, NBS also determined that there are certain operational situations which may lead an inattentive or untrained operator to obtain an inaccurate reading or to associate the speed indicated on the radar device with the wrong vehicle. NBS also points out the potential for obtaining an erroneous reading on a target vehicle under certain conditions when the radar unit is operated in the moving mode. Judgemental errors may occur if police radar operators do not understand and avoid the specific circumstances which give rise to these anomalies.

It is also clear that police administrators must ensure that radar devices are properly maintained and periodically tested and calibrated. Written policy defining maintenance and calibration procedures should be established in each agency. The procedures should define the conditions under which each device should be calibrated by a licensed technician. As a minimum,



we recommend that each radar unit be tested for measurement accuracy annually. The written policy should specify that accurate maintenance, repair, and calibration records for each device should be established and maintained by the agency. These records should be available to the courts, whenever necessary, to verify the accuracy of the device.

While NBS evaluated the six devices mentioned in the Dade County hearing, NHTSA also sponsored a parallel effort to measure the microwave field strengths surrounding 20 models currently in use. The purpose of these measurements was to determine whether the microwave field strengths fell within the exposure limits set by the Occupational Safety and Health Act (OSHA), or new, more stringent proposed standards set by the American National Standards Institute (ANSI). This effort was also undertaken in response to the 1976 International Association of Chiefs of Police (IACP) resolution calling for government concern and involvement in this area.

In sum, the assessment found that even with continuous exposure, no measurements at the aperture of the antennas of all devices tested exceeded the maximum acceptable OSHA exposure levels or the proposed ANSI exposure levels. In the typical case when the operator is clearly not directly in front of the antenna and is no less than three feet or more away from the aperture, the field strengths were either not measureable, or were several orders of magnitude less than the maximum exposure levels allowable.

The text of the NHTSA report prepared by NBS ("Field Strength Measurements of Speed Measuring Radar Units, NHTSA Technical Report No. DOT-HS-805-928)\* is available in Appendix A.

### **Training:**

In July 1980, NHTSA published and circulated a draft model basic operator's training course in radar speed measurement. The final edition is slated for publication in January 1982. The overall goal of this training program is to improve the effectiveness of speed enforcement through the proper and efficient use of police traffic radar devices. The specific objectives of the radar course are to develop and/or improve the trainee's ability to:

- o Describe the association between excessive speed and accidents, deaths and injuries, and describe the highway safety benefits of effective speed control.
- o Describe the basic principles of radar speed measurement.
- o Acquire and demonstrate basic skills in testing and operating the specific radar instruments.

---

\*Copies of the complete report may be obtained from the NTIS, Springfield, VA 22161 under #PB 81 - 240 079.

- o Identify the specific radar instrument(s) used by the trainee's agency and describe the instruments major components and their functions.
- o Identify and describe the laws, court rulings, regulations, policies and procedures affecting radar speed measurement, and speed enforcement in general.
- o Acquire and demonstrate basic skills in preparing and presenting records and courtroom testimony relating to radar speed measurement and enforcement.

The radar training course is designed in a modular format to provide maximum flexibility for the user. It is comprised of eight units, each of which has specific performance objectives. The formal classroom training comprises a block of 24 instruction hours. Upon successful completion of a written exam, the trainee must undergo a minimum of 16 instruction hours of supervised field practice. After completing the course of instruction, the trainee must be able to demonstrate his operational (real world) competency before being certified to take enforcement action based on radar speed evidence. Recertification of all operators should occur within not less than one nor more than three years.

Although this course focuses on enforcement and is intended primarily for the police patrol officer, we recommend participation in the training program by traffic adjudication personnel, e.g., judges, administrative hearing officers, prosecutors, etc. Such personnel routinely decide upon the admissibility and weight of radar speed evidence, the strengths and weaknesses of the instruments, and the capabilities and limitations of the operators. This type of training will provide adjudication personnel with a good working knowledge of radar speed measurement principles and an understanding of the issues relevant to judicial deliberations.

### Conclusions/Recommendations

NHTSA believes that police traffic radar is an effective enforcement tool. The role of police traffic radar in traffic safety enforcement continues to be of critical importance. Police traffic radar provides a means of increasing enforcement effectiveness and thus enables police administrators to better cope with the scarcity of manpower resources and rapidly increasing fuel costs.

Highway safety and law enforcement officials should recognize the fallacy of purchasing radar devices solely on the basis of economy without due regard to their performance capabilities. These officials must also recognize the importance of greatly improved operator training and State-level policy guidance to ensure high quality and more uniform police radar operations throughout a State. Inaction on these issues by State and local highway safety and law enforcement officials may well result in judicial limitations governing the use of police traffic radar.

It is important that each State develop a comprehensive radar speed enforcement program which, as a minimum, embraces model performance specifications for radar operator training, operator certification, and policy/procedural guidance. Accordingly, each State is strongly urged to:

- o Adopt the NBS/NHTSA model radar speed measuring device performance specifications and require police agencies to purchase devices meeting those specifications.
- o Develop policy guidelines to ensure that radar speed measuring devices receive proper care and upkeep and establish clear procedures for programmed maintenance, testing, and calibration.
- o Ensure that adequate maintenance and calibration record systems (suitable for introduction as evidence in court) are developed and maintained by each agency using radar speed measuring devices.
- o Adopt the NHTSA radar operator training program or its equivalent as the statewide minimum training standard.
- o Develop a comprehensive State-level radar operator certification program and provide for periodic recertification (every 1-3 years).
- o Develop police radar workshops and seminars for traffic adjudication personnel.
- o Establish State-level policy/procedural guidelines to ensure proper use of police traffic radar in meeting traffic safety and energy conservation goals and objectives.

Implementation of these measures should result in significantly improved and more uniform radar speed enforcement programs both within the individual States and nationwide. Their implementation is necessary to establish a sound legal foundation for radar speed evidence and to restore public and judicial confidence in radar enforcement programs.

CHAPTER 2

DISCUSSION ABOUT THE MODEL PERFORMANCE SPECIFICATIONS

## Introduction

After thorough review of comments received in response to the proposed rulemaking for performance standards for radar speed measuring devices (see 46 FR 2097-2120), the Agency has decided to terminate the rulemaking process. The benefits of the proposed rule can be achieved without the issuance of a Federal regulation. Therefore, NHTSA is releasing the results of its technical research on radar to the public in the form of these model performance specifications found in Chapter 3 of this report. The States and local jurisdictions are free to adopt these specifications, if they choose.\*

## Background

For almost 30 years radar has been accepted by the courts and public as a reliable tool for measuring vehicular speed. Its use to enforce traffic laws has saved countless lives by deterring motorists from driving at excessive, unsafe speeds. Its continued use and acceptance are vital to improve traffic safety and to conserve energy. It is, therefore, essential that radar devices be accurate.

Until this time, there have been no industry-wide performance standards for police traffic radar devices. State administrators and purchasing agents have had no definitive guidelines on which to base their purchasing decisions. Recognizing these limitations, IACP passed a resolution in 1976 to seek support from NHTSA for the development of "health, safety and performance standards for speed measuring devices, testing of the devices, and publication of tests results."

As a result of the IACP resolution, NHTSA initiated efforts in 1977 to develop performance standards for speed measuring radar devices to meet the needs of the police. NHTSA called upon the expertise of NBS to determine the most desirable and useful features of radar devices. NBS tests formed the basis for the performance standard proposed by the Agency in a notice issued in the Federal Register on December 31, 1980, (46 FR 2097).

The model performance specifications presented in Chapter 3 of this report take into account the Agency's review of the comments submitted in response to the proposed rule. Comments were received from six individuals, nine State or local police or traffic safety departments, three manufacturers, and one university. All comments are available for review or reproduction in Docket No. 81-01, Room 5108, 400 Seventh Street, S.W., Washington, D.C. 20590.

Three commenters expressed their concern over the possibility that the issuance of the standard would trigger challenges in the courts of pre-standard radar devices. An examination of the implications of such challenges led NHTSA to conclude that it has a duty to clarify its position regarding existing radar devices.

---

\*Appendix B contains a model Request for Proposals (RFP) which State and local jurisdictions may consider when procuring radar speed measuring devices. NHTSA is most grateful to the Michigan State Radar Commission for providing us with this model RFP, which we endorse. Of course, individual jurisdictions may need to modify this document to meet their own requirements.

The issuance of these model specifications should not be used by courts to support challenges to existing devices. The specifications do not address such units and are not to be interpreted as a statement of disapproval of existing radar units. It is not the opinion of NHTSA that these units are obsolete, that they should be discarded before the end of their normal useful life or that citations based upon evidence derived from these devices will be unenforceable in courts of law. On the contrary, recent tests conducted by NBS led that agency to conclude that existing radar devices render reliable and valid results when properly installed and used. NHTSA, therefore, must dissuade any challenges to existing devices which are based upon the issuance of these model specifications.

To complement these specifications, NHTSA has also developed and widely distributed a model operator's training course for users of police traffic radar. When adopted by State and local jurisdictions, this model training course should upgrade the quality of radar training that most police officers receive. The training program, coupled with the performance specifications, should ensure the continued reliability and accuracy of radar devices.

The requirements set forth in the model specifications issued here represent those attributes and features of speed measuring devices considered most desirable by a wide consensus of radar users, manufacturers, and courts. They are not intended to preclude or inhibit the development or introduction of new technology in the radar industry. As such advancements are made, the agency will incorporate them into the existing model specifications.

A number of minor changes and clarifications have been incorporated into these model specifications as a result of suggestions made by the commenters to the proposed rule. The most significant objections to the proposed rule and the agency's responses are set forth below:

Minimum range. The proposed rule contained a provision which would have required each radar device operating in the stationary mode to correctly measure and display the speed of a vehicle at a distance of 500 feet. Several commenters stated that the test was not repeatable because the target description and environmental conditions were not sufficiently specific. Some commenters suggested defining the vehicle in terms of its cross section, while another indicated that the exact make, model, and year of the vehicle should be specified. NHTSA shares the commenters' concerns and has deleted this requirement from the model specifications.

Radar horizontal capture angle. The proposed rule would have required manufacturers to specify the radar horizontal capture angle within 10 dB points and to scribe or otherwise mark that angle on the top surface or antenna of each radar device. After reconsideration of this issue, NHTSA has decided that scribing the capture angle onto the antenna would not increase target vehicle identification but could, in fact, mislead the operator in making such identifications by leading him to false conclusions about the beam coverage area. Operators must consider every approaching vehicle as a possible target whose speed could be displayed on the radar device, regardless of its position relative to the radar device. This requires the operator to consider all target vehicles, including those outside the normal parameters of the beam

coverage area. The scribing requirement has accordingly been deleted from the model specifications.

In addition to the potential confusion to operators, the requirement of a radar capture angle label would also create several pragmatic problems. Some radar antennas are quite small and have curved surfaces which could distort the operator's perception of the size of the angle. Separately-mounted antennas are frequently mounted in positions which would prevent the operator from seeing the label while using the equipment, thus also causing a distorted view of the angle of total inability to use it. The agency agrees with the many individuals and organizations who commented that target identification should be a function of operator training and thus has deleted these model specifications.

Antenna horizontal beam width. Considerable attention has been devoted to the proposed maximum beam widths of 18 degrees for type I and II (X-Band) radar and 15° for type III and IV (K-Band) radar devices. Suggestions range from unlimited beam width for stationary devices to 5 degrees for all devices. NBS conducted extensive tests in order to establish beam width values that would result in reliable radar units. The 15 degrees maximum value for K-band (type III and IV) devices was requested by the Intergovernmental Radio Advisory Commission and established by the Federal Communications Commission (FCC) for State and local government use of these devices. For radar operating in X-band frequencies, the testing showed that 18° maximum width will provide satisfactory performance. Beam widths in excess of this value become susceptible to environmental interference, thus reducing radar effectiveness. Beam widths that are too narrow would result in bulkier, larger antennas, and would also make the development of a continuous target tracking history difficult. Therefore, the beam widths as set forth in the model specifications are the same as those in the proposed rule.

Operational Tests. The model specifications suggest that each radar device not be susceptible to erroneous readings from test signals simulating normal exposure to CB and police radios, patrol vehicle ignitions, alternators, air-conditioners, and heater fans. Electromagnetic interference tests are established to ensure compliance with these requirements. To further ensure that devices are not prone to erroneous radiated energy signals, procedures are established for testing the devices against interference from CB and police radios and adjacent vehicle radios in an actual operating environment. The proposed rule would have also required operational field tests to be conducted for interference from vehicle ignitions, alternators, air-conditioners, and heater fans. After thoroughly examining the comments, the agency feels that these latter requirements are adequately addressed in the laboratory tests and has, therefore, omitted them from the model specifications.

While some commenters suggested deleting all the operational tests because the conditions in a field environment are necessarily more variable than those in a laboratory environment, the agency believes that the remaining field tests cannot be simulated in the laboratory using existing techniques and that they provide essential data on the performance characteristics of radar devices. In order to minimize the effect of extraneous variables in the field environment, the agency will insist that testing laboratories use the same make and model vehicle for all field tests.

Speed Accuracy. One commenter suggested that the speed accuracy test should be conducted using a fifth wheel instead of a stopwatch. Such a change would provide accurate speed readings for the target and patrol vehicles and eliminate the necessity for a significant number of test runs on a measured course. However, after reviewing the requirements necessary for a fifth wheel, the agency has concluded that the cost of conducting tests using two fifth wheels greatly outweighs the benefits to be gained, and has therefore decided to retain the stopwatch provisions.

Auto Lock. The elimination of the automatic self-lock capability represents one of the most significant features of the model specifications. The inclusion of the automatic lock would have allowed the radar device to automatically lock onto a vehicle traveling beyond a present threshold speed, thus making it harder for the operator to identify the target being tracked. The auto lock feature of the radar unit occasionally locks onto a vehicle other than the one actually being tracked. By using a radar device without this feature, a skilled and knowledgeable operator can develop a vehicle's tracking history and thereby avoid virtually all of the alleged anomalous readings ascribed to radar operation. The elimination of this feature is consistent with the NHTSA training program which emphasizes that the tracking history is an essential part of radar operation, ensuring proper target vehicle identification.

Audio Alarm. The model specifications suggest omission of audio alarm features which emit an audio signal to alert the operator when a specific speed threshold has been exceeded by a target vehicle. Like the automatic self-lock, the inclusion of this feature can tempt the operator to be careless in his efforts to obtain a proper target history, relying instead on the alarm. In addition, it sometimes disrupts the audio tracking capability of the operator.

Audio Doppler. The model specifications suggest that all devices be equipped with an audio doppler feature, which correlates the speed of the target vehicle with a sound emitted by the radar device and identifies any ambient interference that may be present. It warns the operator when there is an excessive amount of electromagnetic interference, making use of the equipment inappropriate for tracking vehicle speeds. It also helps the operator determine when traffic is too dense to identify individual targets. The agency regards this feature as highly desirable in obtaining a proper tracking history.

Patrol Speed Window--Moving Radar. Some commenters objected to the inclusion of a window to display patrol speed on moving radar on the grounds that the patrol speed could be read directly from the speedometer. It is the opinion of NHTSA that all moving radar operation should be conducted with devices that have a patrol speed window which allows the operator to compare the speed displayed on the radar devices with that registered on the vehicle speedometer. This is the best way to properly identify and counter some of the erroneous readings that can be attributed to moving radar operation.

Test Equipment. Specific suggestions were received from one commenter regarding the selection of some the equipment to be used in the conduct of laboratory procedures for testing. Of specific importance are the comments received with respect to the single-side-band modulator, the pulse generator, and



the AM signal generator. The proposed equipment was selected after a significant amount of testing by NBS laboratories. After careful consideration of the suggestions and review of the NBS testing, we have decided to retain the equipment specified in the proposed rule for the following reasons:

- o Single-side-band modulator (SSB). It was suggested that a double-side-band modulator be used in lieu of the SSB because it is less expensive and produces more accurate results. NBS test experience shows that the SSB provides a clearer signal, generates less noise, and provides more accurate and repeatable results. While the SSB is more expensive, that increase will be approximately five percent, an amount not excessive when compared to the benefits to be gained.
- o Pulse generator. It was suggested that the required 20 volt peak-to-peak (20 v p-p) pulse generator is not necessary and that a 10 v p-p generator would be sufficient. However, actual test experience utilizing a pulse generator with an output of 10 V p-p did not provide the desired results.
- o AM signal generator. Another commenter expressed his opinion that the AM signal generator in the proposed rule was over-specified, suggesting that the 99 percent modulation should be reduced to 90 percent. A survey of CB radios shows that there are a significant number that exceed the 40 to 70 percent modulation range. Therefore, it is our belief that the higher modulation is essential in order to include the widest range CB radios in the marketplace.

Manufacturer Provided Information. A number of comments were received concerning the adequacy of manufacturer provided information. Only minor changes have been made in that section of the model specifications. Manufacturers are strongly encouraged to provide thorough instructions as to the proper installation and use of their devices. These instructions will be used in conducting operational tests. Inadequate instructions may reduce the clarity of procedures that will be used when testing the devices. This situation can be ameliorated by showing to the courts and the public that radar operators received proper training and instructions in the installation and use of radar devices.

As a final note to those commenters who expressed concern that a reference to conformity with FCC regulations does not appear in the proposed rule, NHTSA wants to emphasize that the issuance of these model specifications does not conflict with any requirements established by the FCC or any other regulatory body. All applicable regulations must be complied with. It is the responsibility of each manufacturer to be aware of those requirements that his units must meet. NHTSA will assist those manufacturers who need guidance in this area, but does not consider these model specifications to be the appropriate place to cite those requirements.

The agency still intends to be responsive to the 1976 resolution—regarding police traffic radar issued by IACP. Therefore, we have authorized IACP to adopt these model specifications for radar devices. We expect them to provide their constituents with the best available guidance on police traffic radar devices. The results of this work should fortify their efforts to assist the police in retaining these devices as effective law enforcement

tools, while allowing NHTSA to meet its obligations to provide technical assistance to the traffic law enforcement community. IACP's efforts will involve both (1) oversight of the research/testing program, in collaboration with the NBS and NHTSA; and (2) publication/dissemination of the results of the testing to all interested parties.

NHTSA still believes a research/testing program is an integral part of the assessment of radar devices. The purpose of this testing program will be to provide IACP and the police with definitive test data on how the radar devices on the market perform when compared to the model specifications. Oversight of the testing program will be a cooperative effort involving NBS, IACP, and NHTSA. We anticipate that IACP will publish the findings from these test data in their Technology Assessment Program series, which is widely distributed within the traffic law enforcement community.

### CHAPTER 3

#### MODEL PERFORMANCE SPECIFICATIONS FOR POLICE TRAFFIC RADAR DEVICES\*

\*These specifications were prepared by the Law Enforcement Standards Laboratory (LESL) of the National Bureau of Standards under the direction of Marshal J. Treado, Manager, Communications Systems Program and Lawrence K. Eliason, Chief of LESL. John Wakefield provided the laboratory support required for this effort. The project was completed under Interagency Agreement No. DOT-HS-7-01697 with the National Highway Traffic Safety Administration.

MODEL PERFORMANCE SPECIFICATIONS  
FOR SPEED MEASURING RADAR DEVICES

Subpart A--General

Section

- 1221.1 Scope.
- 1221.2 Purpose.
- 1221.3 Applications.
- 1221.4 Definitions.

Subpart B--Requirements

- 1221.11 Manufacturer provided equipment.
- 1221.12 Manufacturer provided information.
- 1221.13 Labeling requirements.
- 1221.14 Tuning fork calibration requirement.
- 1221.15 Radar device tuning fork requirement.
- 1221.16 Microwave transmission requirements.
- 1221.17 Environmental requirements.
- 1221.18 Low supply voltage requirement.
- 1221.19 Doppler audio requirements.
- 1221.20 Power surge requirements.
- 1221.21 Speed display requirements.
- 1221.22 Electromagnetic interference susceptibility requirements.
- 1221.23 Radar device operational test requirements.
- 1221.24 Speed accuracy.

Subpart C--Test Procedures

Conditions

- 1221.31 Conditions.

Equipment

- 1221.41 Equipment.
- 1221.42 Audiofrequency synthesizer.
- 1221.43 Microphone.
- 1221.44 Environmental chamber.
- 1221.45 Anechoic chamber.
- 1221.46 Microwave frequency counter.
- 1221.47 Field intensity meter.
- 1221.48 Isotropic probe.
- 1221.49 Photometer.
- 1221.50 Simulator test range.
- 1221.51 Line impedance stabilization network (LISN).

- 1221.52 Pulse generator.
- 1221.53 Sawtooth wave generator.
- 1221.54 FM signal generator.
- 1221.55 AM signal generator.
- 1221.56 Power meter.
- 1221.57 Stopwatch.
- 1221.58 Oscilloscope.
- 1221.59 Vibration tester.
- 1221.60 Slide whistle.
- 1221.61 Thermocouple.

#### Procedures

- 1221.71 Tuning fork calibration test.
- 1221.72 Radar device tuning fork test.
- 1221.73 Microwave transmission tests.
- 1221.74 Environmental tests.
- 1221.75 Low supply voltage test.
- 1221.76 Dropller audio tests.
- 1221.77 Speed monitor alert test.
- 1221.78 Power surge test.
- 1221.79 Speed display tests.
- 1221.80 Electromagnetic interference tests.
- 1221.81 Radar device operational tests.
- 1221.82 Speed accuracy test.

Table 1--Minimum performance requirements for speed measuring radar devices.

#### Subpart A--General

##### § 1221.1 Scope.

This part establishes performance requirements and test methods for speed measuring radar devices used by law enforcement agencies to enforce vehicle speed regulations.

##### § 1221.2 Purpose.

The purpose of this part is to specify performance standards for radar devices.

##### § 1221.3 Application.

This part applies to speed measuring radar devices that transmit microwave energy, monitor the reflected signal from moving vehicles within the microwave beam, process the

doppler shift of the reflected signal to display the speed of the vehicle that is being tracked, and if appropriate, the speed of the patrol vehicle. It does not apply to speed measuring radar devices that utilize low power, short range, across-the-road technology.

§ 1221.4 Definitions.

As used in this part:

"Accuracy" when used in conjunction with radar device means the degree to which the radar device measures and displays the correct speed of a target vehicle that it is tracking.

"Ambient Interference" means the conducted and/or radiated electromagnetic interference and/or mechanical motion interference at a specific test location and a time which would be detrimental to proper radar performance.

"Antenna horizontal beam width" means the total included acute angle, in the horizontal plane, of the main lobe between the half-power points of the radar antenna far-field radiation pattern, where the half-power points are measured relative to the maximum power at the center of the beam and on a radius equidistant from the face of the antenna.

"Audio doppler" means an audible signal from a radar device that is generated by driving a loudspeaker with the doppler shift beat frequency or with the doppler shift beat frequency which is divided by a fixed factor, provided that

the audio sound corresponds directly with changes in speed of a target vehicle and any ambient interference present is discernible.

"Automatic lock" means a control function of a radar device that, when activated, causes the device to automatically retain the displayed speed of a target vehicle when the target vehicle speed exceeds some preset value, and preserve that speed displayed until manually reset by the operator.

"Closing speed" means the speed at which an identified radar target is moving relative to the radar device (whether the radar device is moving or not) when measured on a straight line (radius) from the radar to the target.

"Cosine angle effect" means the effect due to the target not travelling directly toward the radar device, which lowers the doppler shift frequency in proportion to the cosine of the angle between the direction of travel of the radar target and a line from the radar device to the target.

"Display" means a visual readout device.

"Doppler shift" means the magnitude of the frequency change of the radar return signal received when the source and the radar reflecting target are in motion relative to one another.

"Erroneous reading" means an incorrect target speed displayed by the radar device, one that is not due to a target vehicle or which is not within the required accuracy tolerance of the speed of a target vehicle, excluding known correction factors such as the cosine angle effect.

"Far-field region" means that region beyond the close proximity of a transmitting antenna defined by the relationship

$$R > \frac{2d^2}{\lambda}$$

where d is the horn diameter and  $\lambda$  is the wavelength of the transmitted frequency, in consistent units.

"Internal circuit test" means a test function (whether manually or automatically initiated) that verifies that all radar device internal signal processing circuitry, except for the microwave transmitter and receiver, is working correctly, i.e., all target and patrol vehicle signals will be properly processed and displayed.

"Just acquired distant target" means a target just within the radar range of a radar device which was originally beyond the range and now provides a display signal of target speed.

"K-Band radar" means a speed measuring radar device designed to operate in the 24,050 to 24,250 MHz frequency band.

"Low voltage indicator" means a radar device component which alerts the operator to the fact that a low supply voltage condition exists.

"Luminance" means the photometric brightness or the luminous intensity of any surface in a given direction per unit of projected area of the surface as viewed from that direction.

"Luminance contrast" means the relationship between the luminance of an object and the luminance of its own background.



"Microwave output power" means that part of the total power produced by the microwave generator in the radar device.

"Moving mode" means the capability of a radar device to measure and display the speed of a target vehicle while the radar device is moving with respect to the surrounding terrain.

"Near-field region" means that region in close proximity to the transmitting antenna that is not included in the region defined as "far-field region."

"Nominal value" means the numerical value of a device characteristic as specified by the manufacturer.

"Patrol channel" means that portion of the radar circuitry of a radar device that processes and calculates the speed of a patrol vehicle when the radar device is operating in the moving mode.

"Patrol speed" means the speed at which the patrol vehicle is moving with respect to the surrounding terrain.

"Polarization" means that property of a radiated electromagnetic wave describing the time-varying direction and magnitude of the electric field vector.

"Power density" means power density per unit area or energy density flux per unit area.

"Side lobes" means radar beams from the antenna which are not part of the primary beam, but which may appear as shoulders on the primary beam.

"Speed display transfer" means the capability of transferring the speed reading from the patrol speed display window to the target speed display window.

"Speed lock switch" means a radar control that causes speed on display as target speed and patrol speed to be retained on display until reset.

"Speed monitor alert" means a function that alerts the operator when a target speed signal is received that is equal to or above some preselected threshold speed.

"Squelch" means the capacity of a radar to inhibit the doppler audio sound when the radar is in operation.

"Standby mode" means a function of a radar device that allows the operator to inhibit power to the microwave oscillator circuit.

"Stationary mode" means the capability of a radar device to operate from a fixed location and display the speed of a target vehicle within the required accuracy tolerance.

"Target channel" means the portion of the radar circuitry that processes the closing speed signal, calculates and displays the speed of a radar target.

"Target speed" means the speed at which the target vehicle is moving with respect to the surrounding terrain.

"Target vehicle" means the vehicle identified as producing a given doppler radar signal that is processed and displayed by the radar device as the target speed.

"Track-Through-Lock" means the feature of a radar device whereby the unit continues to measure, process and accomplish audio doppler tracking and in some cases, real time speed display to the target, after the speed lock switch has been actuated to the lock condition.

"Tuning fork" means a mechanical self-resonant device, which when excited, produces free oscillations that may be used to generate a pseudo doppler frequency reference when placed in the radar antenna beam.

"Type I radar device" means a radar device that transmits microwave energy in the 10,500 to 10,550 MHz frequency band (in the X-band) and operates only in the stationary mode.

"Type II radar device" means a radar device that transmits microwave energy in the 10,500 to 10,550 MHz frequency band (in the X-band) and operates in both the stationary and moving modes.

"Type III radar device" means a radar device that transmits microwave energy in the 24,050 to 24,250 MHz frequency band (in the K-band) and operates only in the stationary mode.

"Type IV radar device" means a radar device that transmits microwave energy in the 24,050 to 24,250 MHz frequency band (in the K-band) and operates in both the stationary and moving modes.

"X-Band radar" means a speed measuring radar device designed to operate in the frequency band of 10,500 to 10,550 MHz.

## Subpart B--Requirements

### § 1221.11 Manufacturer provided equipment.

Each Type I and III radar device shall be accompanied by a minimum of one tuning fork and each Type II and IV radar device shall be accompanied by a minimum of two tuning forks.

### § 1221.12 Manufacturer provided information.

(a) Each radar device submitted for testing in accordance with the provisions of these specifications shall be accompanied by the following minimum information:

(1) Complete instructions for installing the radar in or on the police patrol vehicle or remote from the vehicle including any precautions necessary to minimize or avoid interference from vehicle ignition, heater/air conditioner/defroster blowers or other potentially interfering components.

(2) Complete operating instructions including test procedures, internal circuit test data, required maintenance, and any operating characteristics that are indicative of or symptomatic of possible malfunction of the radar.

(3) Nominal power supply voltage and currents (with and without displays illuminated; with and without target present, and in standby mode if appropriate).

(4) The microwave frequency band of operation.

(5) The nominal value of microwave output power (in mW) as measured by a microwave power meter connected to the microwave oscillator.

(6) Lowest and highest supply voltage level at which the radar is designed to operate, the low voltage alert threshold value and display behavior.

(7) Maximum microwave power density ( $\text{mW}/\text{cm}^2$ ) measured in a plane 2 in (5 cm) distant from the front of the antenna.

(8) Antenna horizontal beam width in degrees.

(9) Type of antenna polarization, i.e., linear or circular and orientation.

(10) Minimum and maximum operating speed of the radar device [target (Types I and III); target and patrol (Types II and IV)].

(11) The highest and lowest temperature at which the unit is designed to operate.

(12) The highest temperature and humidity combination at which the radar device is designed to operate.

(b) Each tuning fork shall be accompanied by a calibration certificate including as a minimum the serial number of the tuning fork, the nominal design speed, a frequency calibration at  $70^\circ\text{F}$  ( $21^\circ\text{C}$ ), the microwave frequency band for which it is to be used (X or K), the calibrated frequency and associated radar speed in mph or km/h, and any correction factor that must be applied to the  $70^\circ\text{F}$  ( $21^\circ\text{C}$ ) calibration speed when used at another temperature.

#### § 1221.13 Labelling requirements

(a) Tuning Fork. The manufacturer shall permanently mark each tuning fork with a serial number, the radar frequency

band that it is to be used with (X or K), and a nominal stationary mode radar speed specification including units (mph or km/h).

(b) Control Functions. The control panel of the radar device shall be permanently marked with the functions and settings of all switches, controls and displays. It shall not be possible to set the controls to a functional model of operation that is not marked or identified on the control panel of the radar device.

§ 1221.14 Tuning fork calibration requirements.

When tested in accordance with § 1221.71, the frequency of vibration of each tuning fork shall be within  $\pm 1/2$  % of that specified by the manufacturer (§ 1221.12(b)) in the certificate of calibration for that tuning fork.

§ 1221.15 Radar device tuning fork requirement.

Each radar device when tested in accordance with § 1221.72 shall meet the following tuning fork requirements, as appropriate.

(a) All Radar Devices. Each radar device, when placed in the stationary mode, shall respond to the signal from the tuning fork within  $\pm 1$  mph ( $\pm 1.6$  km/h).

(b) Type II and IV Radar Devices (Approaching Mode). Each type II and type IV radar device, when set into the approaching, moving mode, shall simultaneously respond to the signals from two vibrating tuning forks of different frequencies, and shall display the calibration speed designated for the lower

frequency tuning fork as the patrol vehicle speed, and the difference between the calibration speed designated for the higher frequency tuning fork and that of the lower frequency tuning fork as the target vehicle speed; both displayed speeds shall be within  $\pm 1$  mph ( $\pm 1.6$  km/h) of the correct values.

(c) Type II and IV Radar Devices (Following Mode).

Each type II and type IV radar device, when placed into the following, moving mode (if such capability is provided by the unit) shall respond to the signals from two vibrating tuning forks of different frequencies, and shall display the calibration speed designated to the higher frequency tuning fork as the patrol vehicle speed, and the sum of the calibration speed designated for the higher frequency tuning fork and that of the lower frequency tuning fork as the target vehicle speed; both displayed speeds shall be within  $\pm 1$  mph ( $\pm 1.6$  km/h) of the correct values.

§ 1221.6 Microwave transmission requirements.

The microwave characteristics of transmission frequency and frequency stability, input current stability, radiated output power stability, antenna horizontal beam width, and antenna near-field power density shall be measured in accordance with § 1221.73 and shall meet the following requirement:

(a) Transmission Frequency and Frequency Stability.

When operated at the standard supply voltage, the transmission frequency shall be within the assigned frequency band of 10,500 to 10,550 MHz for types I and III radar devices and 24,050 to 24,250 MHz for types III and IV radar devices. The transmission frequency shall remain within the assigned frequency bands when the input voltage is varied to  $\pm 20\%$  of the nominal supply voltage or the low voltage value, whichever is lower.

(b) Input Current Stability. When the standard supply voltage is varied  $\pm 20\%$ , the input current shall not vary more than 10% from its nominal value, with no variation in the numerical figure displayed on the target speed display.

(c) Radiated Output Power Stability. The microwave carrier output power shall not vary by more than  $\pm 1.5$  dB from the nominal value when the standard supply voltage is varied  $\pm 20\%$ .

(d) Antenna Horizontal Beam Width. The total included angle between the -3 dB power points of the main lobe of the microwave beam, relative to the maximum power at the center of the beam, shall not exceed 18° for type I and II and 15° for type III and IV radar devices.

(e) Antenna Near-Field Power Density. The maximum antenna near-field power density of each radar device shall not exceed that specified by the manufacturer (§ 1221.12(a)(7)).



§ 1221.17 Environmental requirements.

The ability of the radar device to operate in environmental extremes shall be determined using the appropriate test methods described in § 1221.74 and each radar device shall meet the following requirements:

(a) Operational Temperature Stability. When tested in accordance with § 1221.74(a), following exposure to a temperature of -22°F (-30°C) or the lowest temperature at which the manufacturer states that the radar devices will operate properly (§ 1221.12(a)(11)), whichever is lower, and following exposure to a temperature of 140°F (60°C) or the highest temperature at which the manufacturer states that the device will operate properly (§ 1221.12(a)(11)), whichever is higher, each radar device shall continue to meet the requirements of § 1221.15 and § 1221.16(a) through § 1221.16(c).

(b) Operational Humidity Stability. When tested in accordance with § 1221.74(b) following exposure to 90% relative humidity at 99°F (37°C) for a minimum of 8 hours, each radar device shall continue to meet the requirements of § 1221.15 and § 1221.16(a) through § 1221.16(c).

(c) Vibration Stability. No fixed part of the radar device shall come loose, nor movable part be shifted in position or adjustment, as a result of the test conducted in accordance with § 1221.74(c). During the last 5 minutes of the test in any one direction, the radar device shall respond to the tuning fork signal and shall display the designated tuning fork speed within  $\pm 2$  mph ( $\pm 3$  km/h).

§ 1221.18 Low supply voltage requirement.

Each radar device shall have a low voltage indicator capable of being seen and/or heard by the operator. When tested in accordance with § 1221.75, the low voltage indicator shall operate if the supply voltage is reduced to 10.8 V or the lowest voltage at which the radar device is designed to operate, whichever is lower. When the supply voltage is reduced to the low voltage alarm value, the radar shall not display any erroneous readings when subjected to the tuning fork test (§ 1221.72). A blank display is not considered an erroneous reading.

§ 1221.19 Doppler audio requirements.

The doppler audio output characteristics of audio output and volume control, audio squelch and squelch override and audio track-through-lock and speed monitor alert shall be tested in accordance with § 1221.76 and each radar device shall meet the following requirements:

(a) Audio Output and Volume Control. The radar device shall emit a doppler audio tone that is correlated with the received doppler signal and any interference present, and it shall have an audio volume adjustment control.

(b) Audio Squelch and Squelch Override. When the radar device is operated, the audio doppler tone shall be squelched as long as no target speed signal is being processed. When a target speed signal is present, the doppler audio signal

shall be present in the audio output. The radar device shall permit the operator to inhibit the squelch action to keep the receiver open.

(c) Audio Track-Through-Lock. For those radar devices with a track-through-lock feature, the doppler audio tone shall continue to follow the received doppler signal when the speed lock switch is activated.

(d) Speed Monitor Alert. The radar device shall not have a speed monitoring alert capability.

§ 1221.20 Proper surge requirements.

The power surge characteristics exhibited when turning the radar device from standby to on shall be tested in accordance with § 1221.78. Switching the radar device from standby to on shall not cause any erroneous speed readings with a target present.

§ 1221.21 Speed display requirements.

The speed display characteristics of display readability, display speed lock control, display clear function, internal circuit test function, speed display transfer, signal processing channel sensitivity, target channel speed displays, patrol channel speed displays, and auxiliary displays shall be tested in accordance with § 1221.79 and shall meet the following requirements:

(a) Display Readability. The illuminated segments used to indicate speed readings shall have a minimum daylight luminance contrast of 2.5 when compared with the display

background. The characters used to indicate speed shall be at least 0.4 in (1 cm) high.

(b) Display Speed Lock Control. If provided, the speed lock switch shall preserve the displayed target vehicle and patrol vehicle (types II and IV) speed readings. Such speed lock switch shall require manual actuation by the radar operator and shall not be capable of automatic selflock. When the radar device has a track-through-lock capability, the speed displayed after locking shall be the target speed and patrol speed (type II and IV only) readings that existed at the instant the speed lock switch was activated. The radar device shall not recall a previous speed reading when the speed lock switch is activated.

(c) Display Clear Function. The selection of a different mode of operation of the radar device such as off/on, lock/clear, or stationary/moving mode shall automatically clear the radar device of all displayed readings whether the speed lock switch is activated or not, unless the radar device retains displayed information indicating the mode used to acquire the locked-in target speed. It shall be permissible to accomplish a test sequence without clearing locked-in speed readings.

(d) Internal Circuit Test Function. The radar device shall have a self test function that, when activated, determines whether or not internal signals will be processed and displayed to within  $\pm 1$  mph (1.6 km/h). The radar device shall display the correct reading(s) when performing the

internal circuit test function and it shall be impossible for the radar device to lock in the speed displays caused by this test. These readings shall be cleared when the radar is switched to another mode of operation. The internal circuit test switch shall not be labeled "Cal" or "Calibrate".

(e) Speed Display Transfer. In the moving mode the radar device shall not be capable of transferring the patrol speed reading from the patrol speed display to the target speed display.

(f) Signal Processing Channel.

(1) Stationary Mode Target Channel Sensitivity. When the radar device is operated in the stationary mode, its signal processing channel sensitivity shall not vary more than 10 dB for targets traveling at speeds of 20 to 90 mph (32 to 144 km/h) nor more than 3 dB for targets traveling at speeds of 60 to 90 mph (96 to 144 km/h).

(2) Moving Mode Target Channel Sensitivity (Type II and IV Only). When the radar device is operated in the moving mode at 25 mph (40 km/h), its signal processing channel sensitivity shall not vary more than 10 dB for targets traveling at speeds of 40 to 90 mph (64 to 144 km/h), except for those targets traveling at the patrol speed or a multiple of the patrol speed. When operated at 50 mph (80 km/h), its closing speed sensitivity shall not vary more than 3 dB for targets traveling at speeds of 60 to 90 mph (96 to 144 km/h), except for those targets traveling at the same speed as the patrol speed.

(g) Target Channel Low and High Speed Displays.

(1) The target signal processor channel and target speed display shall function as specified in the test procedure at § 1221.79(g) at a speed of 20 mph (32 km/h) or the lowest speed at which the manufacturer states that his device will operate properly, whichever is lower, when operating in the stationary or moving mode.

(2) The target signal processor channel and target speed display shall function as specified in the test procedure at § 1221.79(g) at a speed of 100 mph (160 km/h) when operating in the stationary mode. While operating in the moving mode, type II and IV radar devices shall process closing speeds of at least 155 mph (248 km/h) but type IV radars shall not process closing speeds of 210 mph (336 km/h) or greater.

(h) Patrol Channel Speed Displays (Type II and IV Radar Devices).

(1) Low and High Speed Readings.

(i) The patrol signal processor channel and patrol speed display shall function as specified in the test procedure at § 1221.79(h)(1) at speeds down to 20 mph (32 km/h) or the lowest speed at which the manufacturer states that his unit will operate properly (§ 1221.12(a)(10)), whichever is lower, when operating in the moving mode.

(ii) The patrol signal processor channel and the patrol speed display shall function as specified in the test procedure at § 1221.79(h)(1) at a speed of 55 mph (88 km/h) or the

highest speed at which the manufacturer states that his unit will operate properly (§ 1221.12(a)(10)), whichever is higher when operating in the moving mode.

(2) Patrol Vehicle Speed Changes. When tested in accordance with § 1221.79(h)(2) the patrol signal processor channel shall track the patrol car speed within + 1 mph (1.6 km/h) and maintain proper radar performance while the patrol car changes speed at a rate of 3 mph (4.8 km/h) per second.

(i) Auxiliary Displays. If the radar device has auxiliary speed displays, the requirements specified for the target channel and patrol channel speed displays shall apply to the auxiliary displays.

(1) If the radar device utilizes a printing device to permanently record the speed display readings, this printed record shall show the operating status (stationary or moving mode), the retained patrol vehicle and target vehicle speeds and the time of day and date at which the speed lock switch was activated.

(2) If the radar device utilizes a separable, remote module, this remote module shall display as a minimum the retained target vehicle speed. The remote module shall clear all displays when reconnected to the radar device or when a display clear function occurs.

§ 1221.22 Electromagnetic Interference Susceptibility Requirements.

The susceptibility of the radar device to simulated electromagnetic interference from the vehicle alternator, vehicle ignition, air conditioner/heater motor, windshield wiper motor and typical police and citizens band transceivers shall be tested in accordance with § 1221.80. During these tests, a blank target speed display shall not be considered an erroneous reading. Each radar device when tested in accordance with § 1221.80 shall meet the following requirements:

(a) Simulated Vehicle Alternator Interference. When subjected to a 10-20  $\mu$ sec wide pulse signal of 1 V peak-to-peak amplitude (except for transition spikes) having a maximum rise time of 2  $\mu$ sec and a maximum fall time of 2  $\mu$ sec (both excluding ringing) and having a ringing time no greater than 8  $\mu$ secs, with a pulse repetition rate between 200 and 10,000 pulses per second (pps), the radar device shall not display any erroneous readings.

(b) Simulated Vehicle Ignition, Air Conditioner/Heater Motor and Windshield Wiper Motor Interference. When subjected to a negative ramp sawtooth wave signal of 1 V peak-to-peak with a positive rise time of a maximum of two  $\mu$ sec over a frequency range of 200 to 10,000 Hz, the radar device shall not display any erroneous readings.

(c) Simulated Police FM Transceiver Interference. When subjected to a 10 mW frequency modulated (FM) radio frequency



signal in each police radio frequency band, the radar device shall not display any erroneous speed readings.

(d) Simulated Citizen Band (CB) AM Transceiver Interference. When subjected to a 5 mW amplitude modulated (AM) radio frequency in any of the CB channels specified in § 1221.80(d), the radar device shall not display any erroneous speed readings.

§ 1221.23 Radar device operational test requirements.

The operational test requirements of radio frequency transceiver interference and speed accuracy shall be tested in accordance with § 1221.81. During these tests, a blank target speed display shall not be considered an erroneous reading. Each radar device shall meet the following requirements:

(a) Police FM Transceiver Interference. The radar device shall not display any erroneous speed readings when a police FM radio transceiver properly installed in the radar-equipped patrol vehicle is operated while the patrol vehicle is standing still with the radar device in the stationary mode and tracking a just-acquired distant target traveling at a speed of 50 mph (80 km/h). The radar device shall not display any erroneous readings when a handheld police FM transceiver with an integral antenna is operated inside the patrol vehicle under similar circumstances.

(b) Citizens Band (CB) AM Transceiver Interference. The radar device shall not display any erroneous speed readings when a CB AM transceiver properly installed in the radar equipped patrol vehicle is operated while the patrol vehicle is standing still with the radar device in the stationary mode and tracking a just-acquired distant target traveling at a speed of 50 mph (80 km/h).

(c) Adjacent Vehicle Radiofrequency Interference.

(1) The radar device shall not display any erroneous speed readings when a second vehicle with an operating police FM transceiver is driven within 10 ft (3 m) of the stationary patrol vehicle while the radar device is operating and tracking a just-acquired distant target traveling at a speed of 50 mph (80 km/h).

(2) The radar device shall not display any erroneous speed readings when a second vehicle with an operating CB AM transceiver is driven within 10 ft (3 m) of the stationary radar patrol vehicle while the radar device is operating and tracking a just-acquired distant target traveling at a speed of 50 mph (80 km/h).

§ 1221.24 Speed accuracy.

When tested in accordance with paragraph § 1221.82, each radar device shall display the correct speed of a target vehicle traveling at speeds of 20 to 100 mph (32 to 160 km/h) within  $\pm 1$  mph ( $\pm 1.6$  km/h) when operated in the stationary mode. Type II and IV radar devices shall display the correct

patrol vehicle speed and target vehicle speed of a radar target within  $\pm 2$  mph ( $\pm 3.2$  km/h) when operated in the moving mode.

#### Subpart C--Test Procedures.

##### Conditions

##### § 1221.31 Conditions.

Allow all measurement equipment to warm up until the system has achieved sufficient stability to perform the measurement. Unless otherwise specified, perform all measurements under standard test conditions, as follows:

(a) Standard Temperature. Standard ambient temperature shall be between 68°F (20°C) and 86°F (30°C).

(b) Standard Relative Humidity. Standard relative humidity shall be between 10 and 85%.

(c) Standard Supply Voltage. In a nominal 12 V dc system, the standard supply voltage shall be 13.6  $\pm$ .1 V. A well filtered electronic power supply capable of a voltage adjustment of  $\pm 20\%$  should be used for laboratory testing and is recommended for other tests in place of the battery for safety and convenience. The standard supply voltage shall be applied to the input terminals of the dc supply cables (including all connectors and circuit protectors) furnished by the manufacturer and adjusted to within 1% of the above value.

(d) Standard supply input current. The standard input current shall be the value measured while the radar is operating but is not receiving a target signal.

(e) Special instructions. Each time a test method requires that the radar device be connected to the simulator test range (hereafter called "simulator"), the radar device must also be connected to the standard supply voltage source and properly aligned on the simulator.

### Equipment

#### § 1221.41 Equipment.

The test equipment discussed in this section is limited to that equipment which is most critical in making the measurements discussed in this document. All other test equipment shall be of laboratory instrumentation quality. All test equipment, except the anechoic chamber, shall be provided with instruction manuals.

#### § 1221.42 Audiofrequency synthesizer.

The audiofrequency synthesizer shall have a frequency range of 300 to 10,000 Hz, a resolution of at least 0.01 Hz, and a measurement uncertainty no greater than 1 part in  $10^6$ .

#### § 1221.43 Microphone.

The microphone shall have a frequency range of 300 to 10,000 Hz and shall be capable of coupling tuning fork tones into an amplifier or oscilloscope.

§ 1221.44 Environmental chamber.

The environmental chamber or chambers shall produce air temperatures that meet the requirements of § 1221.17(a) and § 1221.17(b) while shielding the test radar device from heating or cooling air currents blowing directly on it. The temperature of the radar device shall be measured with a thermocouple (§ 1221.61) separate from the sensor used to control the chamber air temperature and shall have an accuracy of  $\pm 2^{\circ}\text{F}$  ( $\pm 1^{\circ}\text{C}$ ). Likewise, humidity shall be measured with a hygrometer separate from the sensor used to control humidity and shall have an accuracy of  $\pm 2\%$ .

§ 1221.45 Anechoic chamber.

The rf anechoic chamber shall be shielded to exclude outside interference and shall be constructed to minimize internal microwave reflections from the chamber walls, floor and ceiling.

§ 1221.46 Microwave frequency counter.

The microwave frequency counter shall be capable of measuring microwave frequencies from 10,500 to 10,550 MHz and from 24,050 to 24,250 MHz with an uncertainty no greater than 1 part in  $10^7$ .

§ 1221.47 Field strength meter.

The field strength meter shall have a probe with omnidirectional pickup characteristics and a 4 in (10 cm)

diameter protective sphere, and shall be capable of measuring E-field power densities from 0.01 mW/cm<sup>2</sup> to 10mW/cm<sup>2</sup> with an accuracy of + 1dB.

§ 1221.48 Isotropic probe.

The isotropic probe shall have sensor antennas consisting of three orthogonal dipoles enclosed in a 4 in (10 cm) diameter protective sphere, a minimum detectable power density level of 0.01 mW/cm<sup>2</sup> over the frequency range of 10 to 25 GHz, and high resistance between the sensor and metering units.

§ 1221.49 Photometer.

The photometer shall incorporate a photopic response which closely approximates the Commission International de l'Eclairage (CIE) luminous efficiency function and have optics which allow the measurement of circular areas as small as 0.004 in (0.01 cm) in diameter. The photometer shall have a full scale sensitivity of at least 0.1 foot-lambert (0.34 candela per square meter (cd/m<sup>2</sup>)). Measurement uncertainty of the calibrated photo shall be less than 5% of the reading.

§ 1221.50 Simulator test range.

The simulator test range shall have the capability of mounting the radar device in an interference free environment and the means of generating modulation reflection signals as pseudo doppler audio signals. It shall be able to simultaneously produce simulated patrol and target vehicle

speeds. The simulator test range shall consist of a mounting bench, two audio signal generators and microwave single side-band (SSB) modulator. The audio generators shall operate from 300 to 15,000 Hz with frequency counters having an uncertainty of less than 1 part in  $10^6$  and shall have a calibrated output with an accuracy of  $\pm 2$ dB. If integral frequency counters are not included, separate counters with the required accuracy shall be used. The SSB modulator shall be capable of generating SSB modulation for frequencies of 300 to 16,000 Hz, and test personnel shall be able to monitor visually the microwave signal level and the modulator balance adjustment.

§ 1221.51 Line impedance stabilization network (LISN).

The line impedance stabilization network, constructed as in figure 1 with shielded terminals, shall be capable of simultaneously interfacing with the radar device, the standard supply voltage source, and the interference injection generator.

§ 1221.52 Pulse generator.

The pulse generator shall be capable of producing 20 V peak-to-peak across a 50 ohm output impedance with rise and fall times of less than one  $\mu$ sec and pulse repetition rates to 200 to 10,000 pulses per second.

§ 1221.53 Sawtooth wave generator.

The sawtooth wave generator shall be capable of producing 20 V peak-to-peak across a 50 ohm output impedance. It shall

also be capable of producing a sawtooth wave having a positive-going, leading-edge, fast rise-time wave of less than one  $\mu$ sec over a frequency range of 200 to 10,000 Hz.

§ 1221.54 FM signal generator.

The FM signal generator shall be capable of producing 20 mW output power at frequencies from 30 to 500 MHz and shall have an audio frequency modulation variable from 500 to 5000 Hz, a 50-ohm output impedance, a maximum standing wave ratio of 1.2 and a variable output level. It shall also have a deviation meter or calibrated control for determining the peak frequency deviation with an uncertainty no greater than 10%.

§ 1221.55 AM signal generator.

The AM signal generator shall cover the 25 to 30 MHz frequency range, be capable of producing at least 20 mW output power and 99% modulation of frequencies from 500 to 5000 Hz, have a 50-ohm output impedance and a maximum standing wave ratio of 1.2. The generator should include a digital frequency counter having an uncertainty no greater than 1 part in  $10^6$  and an AM monitor or calibrated control for determining the AM percentage with an uncertainty no greater than 10%. If an integral frequency counter is not included, a separate frequency counter having the required accuracy shall be provided.



§ 1221.56 Power meter.

The power meter shall have 50-ohm feed-through detectors for frequencies from 20 to 500 MHz and the ability to handle powers up to 50 watts with an accuracy of 10% or better.

§ 1221.57 Stopwatch.

The stopwatch shall have a 1.1 sec resolution or better and a total time accumulation of at least 5 min.

§ 1221.58 Oscilloscope.

The oscilloscope shall have a vertical input sensitivity (y-axis) of 10mV/cm or better and a frequency response of at least 5 MHz. It shall also have a horizontal input (x-axis) having at least 20 kHz frequency response and a horizontal sweeptime base resolution of 100  $\mu$ sec/cm or better. It shall provide a reference voltage, accurate to 5% or better, for calibrating the vertical input.

§ 1221.59 Vibration tester.

The vibration tester shall be adjustable in frequency from 10 to 60 Hz, in a linear-sweep mode, and it shall be servo-controlled, with a reference signal derived from a suitable calibrated accelerometer or other calibrated sensor. It shall also provide an adjustable simple harmonic motion in at least one plane for a total excursion of 0.04 in (1 mm).

§ 1221.60 Slide whistle.

The slide whistle, a wind instrument with notched hollow tube and a variable displacement, shall be capable of producing audiofrequency notes from 500 to 3000 Hz.

§ 1221.61 Thermocouple.

The thermocouple shall be an American National Standards Institute (ANSI) type T thermocouple. Reference tables from ANSI/ASTM E 230-77, Standard Temperature, shall be used to convert electromotive force into measured temperature. At least one thermocouple shall be installed within the case of each radar device for temperature measurement purposes.

Procedures

§ 1221.71 Tuning fork calibration test.

Interconnect the test equipment as shown in figure 2 except that a frequency counter and amplifier may be substituted for the audiofrequency synthesizer and the oscilloscope. If used, adjust the audiofrequency synthesizer to approximately the tuning fork frequency by multiplying the labeled tuning fork speed by 31.3906 for type I and II radar devices and by 72.0301 for type III and IV radar devices. After striking the tuning fork on a non-metallic object, wait 3 seconds, then hold it in front of the microphone while adjusting the synthesizer frequency to obtain a stationary, circular, lissajous pattern on the oscilloscope. Record the tuning fork frequency directly from the synthesizer dials. Divide

the synthesizer frequency or the frequency as measured by the counter by the appropriate constant given above to obtain the speed corresponding to the measured frequency of the tuning fork.

§ 1221.72 Radar device tuning fork test.

(a) All Radar Devices. Place the radar device in the stationary mode of operation, orienting the antenna so that no moving targets are present. Activate the tuning fork by striking it on a non-metallic object and hold it 1 to 4 in (2.5 to 10 cm) in front of the antenna with the flat side parallel to the direction of propagation. The radar must display the speed corresponding to the tuning fork frequency in the target vehicle speed window.

(b) Type II and IV Radar Devices (Approaching Mode). Place the radar in the moving mode of operation, orienting the antenna so that no moving targets are available to the radar. Activate the lower speed tuning fork by striking it on a non-metallic object and hold it 1 to 4 in (2.5 to 10 cm) in front of the antenna with the flat side parallel to the direction of propagation. The radar should display the tuning fork speed in the patrol vehicle speed window. Strike the higher speed tuning fork on a non-metallic object and place in front of the antenna alongside the lower speed tuning fork. The speed corresponding to the low-speed tuning fork frequency must remain in the patrol vehicle speed display window and the target vehicle speed display

must indicate the difference in speed between the two tuning forks.

(c) Type II and IV Radar Devices (Following Mode).

Place the radar in the following mode of operation, orienting the antenna so that no moving targets are available to the radar. Activate the higher speed tuning fork by striking it on a non-metallic object and hold it 1 to 4 in (2.5 to 10 cm) in front of the antenna with a flat side parallel to the direction of propagation. The radar must display the speed corresponding to the tuning fork frequency in the patrol display window. Strike the lower speed tuning fork on a non-metallic object and place in front of the antenna alongside the high speed tuning fork. The speed corresponding to the high speed tuning fork frequency must remain in the patrol vehicle speed display window and the target vehicle speed display must indicate the sum of the two tuning forks.

§ 1221.73 Microwave transmission tests.

(a) Transmission Frequency and Frequency Stability Test.

(1) Place the radar device in the anechoic chamber and connect the test equipment as shown in figure 3. Position the pickup horn antenna in the radar beam a sufficient distance away from the radar device to prevent overdriving the microwave frequency counter. Adjust the standard supply voltage to its nominal value and record the microwave frequency.

(2) Reduce the standard supply voltage by 20% of its nominal value, allow it to stabilize for 2 min., and repeat the above procedure.

(3) Repeat the procedure for a change in standard supply voltage of +20%.

(b) Input Current Test. Place the radar device in the anechoic chamber and connect the test equipment as shown in figure 4. Adjust the standard supply voltage to its nominal value and record the input current and voltage. Vary the standard supply voltage +20% and record the change in input current. Repeat for a supply voltage of -20% of the nominal value.

(c) Radiated Output Power Stability Test. Position the radar device on a vertical test stand in the anechoic chamber with the antenna pointed upward, and connect the test equipment as shown in figure 5. Mount the isotropic probe of the field intensity meter 20 to 40 in (50 to 100 cm) from the radar antenna in the longitudinal axis of the radar beam. Adjust either the radar or the probe horizontally to position the probe in the center of the principal axis of the beam (maximum probe reading). Record the distance between the antenna aperture and the isotropic probe, adjust the standard supply voltage to its nominal value and record the field strength of the microwave output signal. Vary the standard supply voltage  $\pm 20\%$  and record the change in microwave output power density.

(d) Antenna Horizontal Beam Width Tests. Use either test (1) or test (2) below, as appropriate:

(1) Antenna Horizontal Beam Width Test. Position the radar device on a vertical test stand in the anechoic chamber, with the antenna pointed upwards, and connect the test equipment as shown in figure 5. Mount the isotropic probe of the field intensity meter 20 to 40 in (50 to 100cm) above the radar antenna. Energize the radar using standard supply voltage and allow it to stabilize for 2 min. Adjust the position of the radar device on the test stand until the probe is in the center of the antenna beam (maximum power), then adjust the height of the probe for a full scale or reference level on a sensitive scale of the field strength meter, maintaining the probe in the antenna far-field region. Record the field intensity and the distance between the antenna and the probe. Using caution not to accidentally rotate it, move the radar device to the right until half-power is indicated on the meter and carefully mark the position of the radar device. Move the radar device to the left of the probe until half-power is again indicated on the meter. Mark this point and measure the distance between the half-power points.

Moving the radar device on a path  $90^\circ$  to the previous direction, again measure the distance between the half-power points. Average the distances between the two half-power

readings and calculate the half-power beam width using the following equation to correct for any change in radius distance.

$$A = 2F \text{ Arctan } (C/2R)$$

Where A is the angular half-power beam width, F is a factor to correct for the change in radius (from the graphed curve, figure 6), C is the average perpendicular distance between the half-power points, and R is the radius from the front of the antenna to the point at which the maximum power density was measured.

(2) Antenna Horizontal Beam Width Test (Alternate Method for Circularly Polarized Radar Devices Only). Position the radar device on a turntable in the anechoic chamber, energize it using the standard supply voltage and allow it to stabilize for 2 min. Position a pickup horn antenna on the maximum power axis of the antenna far-field region at a distance close enough to indicate full scale on the power meter on a sensitive scale. Record the protractor angle indication on the radar mounting turntable. Rotate the turntable with the radar until the power meter indicates one-half the power read at the center of the beam, record the turntable angle and then rotate the turntable back through center, continuing until the power meter again indicates one-half the power read at the center and record the turntable angle. The change in angle readings of the turntable between the two half-power points shall be taken as the antenna beam width measurement.

(e) Antenna Near-Field Power Density Test. Connect the radar device to the test equipment as shown in figure 7. Being careful not to vary the distance from the antenna, use the isotropic probe to search for the maximum signal strength in the plane 2 in. (5 cm) from the antenna aperture or lens face of the antenna and perpendicular to the longitudinal axis of the radar beam. Move the probe to obtain the maximum reading and record it.

§ 1221.74 Environmental tests.

(a) Operational Temperature Test. Place the radar device, with the power off, in the environmental chamber and adjust the chamber to the required low temperature  $\pm 3.6^{\circ}\text{F}$  ( $\pm 2^{\circ}\text{C}$ ). Allow the radar device to reach temperature equilibrium and maintain it at this temperature for 30 min. Using protective gloves, remove the radar device from the environmental chamber, place it in the anechoic chamber and connect it to the standard supply voltage. After energizing, wait 2 min. before performing any measurements. The radar shall meet the requirements of § 1221.17(a) within 15 min. of operation. Repeat the above procedure at the required high temperature  $\pm 3.6^{\circ}\text{F}$  ( $\pm 2^{\circ}\text{C}$ ).

(b) Operational Humidity Test. Place the radar device, with the power off, in the environmental chamber. Adjust the relative humidity to a minimum of 90% at  $99^{\circ}\text{F}$  ( $37^{\circ}\text{C}$ ) and maintain the radar device at these conditions for at least 3 hours. Remove the radar device from the chamber, place it in the



anechoic chamber and connect it to the standard supply voltage. After energizing, wait 2 min. before performing any measurements. The radar device shall meet the requirements of § 1221.17(b) within 15 min. of operation.

(c) Vibration test.

(1) Fasten the radar device to the vibration tester using a rigid mounting fixture. Perform a two-part test for a total of 30 min. in each of three directions, namely the directions parallel to both axis of the mounting and perpendicular to the plane of the mounting.

(2) First subject the radar device to three 5 min. cycles of simple harmonic motion having an amplitude of 0.015 in (0.38 mm) [total excursion of 0.03 in (0.76 mm)] applied initially at a frequency of 10 Hz and increased at a uniform rate to 30 Hz in 2.5 min., then decreased at a uniform rate to 10 Hz in 2.5 min. Conduct the appropriate radar device tuning fork test (§ 1221.72) during the last 5 min. cycle.

(3) Then subject the radar device to three 5 min. cycles of simple harmonic motion having an amplitude of 0.0075 in (0.19 mm) [total excursion of 0.015 in (0.38 mm)] applied initially at a frequency of 30 Hz and increased at a uniform rate to 60 Hz in 2.5 min., then decreased at a uniform rate to 30 Hz in 2.5 min. Conduct the appropriate radar device tuning fork test (§ 1221.72) during the last 5 min cycle.

(4) Repeat this procedure for each of the other two directions.

§ 1221.75 Low supply voltage test.

Connect the radar device to the standard supply voltage as shown in figure 3 and energize it. Allow the radar device to stabilize for 2 min., then conduct the appropriate radar device tuning fork test (§ 1221.72) and measure the radar speed generated by the tuning fork frequency. Continue to measure the radar speed and decrease the supply voltage at the rate of approximately 0.2 V/s until the low voltage alert is activated. Record the supply voltage level. Verify that no erroneous reading is present. Increase the supply voltage until the low voltage indicator is deactivated, and again conduct the appropriate radar device tuning fork test to verify that the radar device yields the same speed reading as at standard supply voltage.

§ 1221.76 Doppler audio tests.

Each time a test method requires that the radar device be connected to the simulator, the radar device must also be connected to the standard supply voltage source and properly aligned on the simulator. See figure 8 for a block diagram of this measurement setup. The following procedures shall be followed:

- (a) Audio Output and Volume Control Test.

(1) Connect the radar device to the simulator, energize it in the stationary mode and disable the squelch function. Establish a simulated target and vary the target speed to verify that the doppler audio is correlated with the target speed. In a single target situation, stationary mode, the doppler audio should be a single clear tone. Move a metal plate in the radar beam without interrupting the signal beam and ascertain that the interference motion from the plate is heard in the doppler audio. For type II and IV radar devices, switch to moving mode operation and use the simulator to establish a simulated moving mode situation. Vary the target speed control and verify that the simulated target doppler audio is correlated with the target speed, whether the patrol doppler audio is present or not.

(2) Vary the audio volume adjustment control.

(b) Audio Squelch and Squelch Override Test.

(1) Connect the radar device to the simulator and energize it in the stationary mode with no target present. Verify that the audio output is squelched.

(2) Disable the squelch function and move a metal plate within the radar beam and ascertain that this motion is heard in the doppler audio.

(c) Audio Track-Through-Lock Test.

(1) Connect the radar device to the simulator, energize it in the stationary mode with doppler audio squelched. Establish a simulated target, actuate the speed lock switch and verify

that the doppler audio continues uninterrupted. Increase the simulated target speed and verify that the doppler audio is correlated with the target speed.

(2) Repeat the above procedure using a decreased simulated target speed.

(3) For type II and IV radar devices switch to the moving mode of operation, establish a simulated fixed patrol speed and a variable target speed and repeat the above procedure.

§ 1221.77 Speed monitor alert test.

Verify that the radar device does not have a speed monitor alert capability.

§ 1221.78 Power surge test.

Conduct the following test on any devices with a standby capability. Adjust all range sensitivity controls and audio volume controls to maximum for these tests. Connect the radar device to the simulator. Place the radar device in the stationary mode, establish a simulated target of 50 mph (80 km/h), and switch the device to standby mode. Turn the device from standby to on and verify that there are no erroneous readings. Repeat this three times. For type II and IV radar devices, switch to the moving mode and repeat the above procedure.

§ 1221.79 Speed display tests.

(a) Display readability tests. Position the radar

device with the illuminated face perpendicular to the optical axis of the photometer as shown in figure 9. Position a light source at an angle of 30° from the perpendicular such that 1000 footcandles (10,780 lumens per square meter) of illumination will be measured across the face of the display. Turn on the display using standard supply voltage and use a tuning fork to place a speed reading on the display. Lock in the reading and darken the room. Vary the intensity of the display to obtain the maximum luminance contrast. Use the photometer to measure the luminance of an individual character element, either a bar or a single dot, and its background at three locations, if possible, representing the left, center and right portions of the display. Repeat for illumination angles of 45° and 60°. Record the values of daylight luminance contrast for each of the nine tests and calculate the average value of  $L_1$  and  $L_2$  defined below). Calculate the daylight luminance contrast value from

$$C = \frac{L_1 - L_2}{L_2} \quad \text{or}$$

$$C = \frac{L_2 - L_1}{L_1}, \quad \text{if } L_2$$

is greater than  $L_1$ ,

where  $C$  is the luminance contrast,  $L_1$  is the luminance of the display element, and  $L_2$  is the luminance of the background immediately surrounding the display element.

Measure the height of a typical display character.

(b) Display Speed Lock Tests.

(1) These tests may be performed in conjunction with the display clear test (paragraph (c) of this section) for convenience. Connect the radar device to the simulator and establish a simulated target. Verify that the radar device has no automatic speed lock capability. Place the radar device in the stationary mode and activate the speed lock switch to retain the target vehicle speed reading. Increase the target speed, then discontinue the simulated target and verify that the target speed display has retained the correct speed reading.

(2) Clear the radar device and again establish a simulated target, but do not activate the speed lock switch. Discontinue the simulated target, wait for the display to blank, and then activate the speed lock switch. Verify that the target speed display remains blank.

(3) For type II and IV radar devices establish both a simulated target and a simulated patrol vehicle speed. Proceed as above except that both the target speed display and the patrol speed display must be observed.

(c) Display Clear Test.

(1) Connect the radar device to simulator, energize it in the stationary mode, establish a simulated target, then turn off the simulated signal. Activate any one of the control switches (on, off, standby, test, etc.) on the radar device

except the speed lock switch and verify that the previous speed reading has not been preserved. Repeat for each control switch on the radar device. For type II and IV radar devices, switch to the moving mode and repeat the above procedure.

(2) With the radar device still connected to the simulator, again establish a simulated target. Lock in this speed reading using the speed lock switch. Activate any one of the control switches on the radar device except standby and test, and verify that the previous speed reading has not been preserved. Repeat for each control switch on the radar device.

(d) Internal Circuit Test. Activate the radar device and perform the internal circuit test in accordance with the instructions of the manufacturer. Verify that only correct readings are displayed, and that all readings are cleared automatically when the test is completed. Repeat the internal circuit test a second time and attempt to actuate the speed lock switch while readings are displayed. Verify that these readings are not retained by the display.

(e) Speed Display Transfer Test. Connect the radar device to the simulator, set it to the moving mode and establish a moving mode simulated patrol and target speeds. Activate the speed-lock switch and discontinue the simulated signals. Using each of the available controls, attempt to transfer the patrol speed reading to the target speed display.

(f) Signal Processing Channel Sensitivity Tests.

(1) Connect the radar device to the simulator and establish a 20 mph (32 km/h) simulated target speed or the lowest target speed specified by the manufacturer. Do not move the radar device for the remainder of this test. Place the radar device in the stationary mode, increase the target signal by adjusting the generator output or audio attenuator and record the target speed minimum signal level needed to acquire the target. Repeat for target speeds of 30 to 90 mph (48 to 144 km/h) at 10 mph (16 km/h) increments.

(2) For type II and IV radar devices, place the radar device in the moving mode, establish a 25 mph (40 km/h) simulated patrol vehicle speed and then increase the patrol speed signal level by 10 dB (5 dB is using a microwave attenuator). Establish a 40 mph (64 km/h) simulated target, acquire it and record the target speed minimum signal level needed to reacquire the target. Repeat for target speeds of 50 to 90 mph (80 to 144 km/h) at 10 mph (16 km/h) increments. Repeat at the procedure for a simulated patrol speed of 50 mph (80 km/h) and target speeds of 60 to 90 mph (96 to 144 km/h) at 10 mph (16 km/h) increments.

(g) Target Channel Low and High Speed Display Tests.

(1) Connect the radar device to the simulator. With radar device in off or standby, establish a simulated target traveling at the required low speed. Switch the radar device to the stationary mode to verify that it will acquire this



target and measure its speed. For type II and IV radar devices, establish a simulated patrol speed of 20 mph (32 km/h), switch the radar device to the moving mode and repeat this procedure.

(2) Switch the radar device to the stationary mode and repeat this procedure using the required high speed target speed.

(3) For type II and IV radar devices, with simulated target traveling at 100 mph (160 km/h) and a patrol vehicle speed of 55 mph (88 km/h), verify that the target signal processing channel will process and display the correct speed readings. For type IV radar devices, change the closing speed to 210 mph (336 km/h), with maximum patrol speed of 55 mph (88 km/h), and verify that the radar device will not process and display any target speed reading.

(h) Patrol Channel Speed Display.

(1) Low and High Speed Tests.

Connect the radar device to the simulator. With the radar device in off or standby, establish a simulated target speed signal at the required low speed. Switch the radar device to the moving mode and verify that it will acquire and measure patrol speeds down to the required low speed. With the radar device still in the moving mode, establish a simulated patrol speed of 55 mph (88 km/h) and repeat the procedure. Verify that the radar device will acquire and measure patrol speeds up to the required high speed.

(2) Patrol Vehicle Speed Change Test.

(1) Connect the radar device to the simulator and establish a patrol speed of 20 mph (32 km/h). Place the radar device in the moving mode and display the correct patrol speed. Use the simulator to increase the patrol speed at a rate of 3 mph per second for 5 seconds and verify that the patrol speed display reading agrees with the simulated patrol speed during this 5 second period. Repeat this procedure for initial patrol speeds of 30 and 40 mph (48 and 64 km/h).

(ii) With the radar device still connected to the simulator, establish a patrol speed of 55 mph. Place the radar device in the moving mode and display the correct patrol speed. Use the radar target simulator to decrease the patrol speed at a rate of 3 mph per second for 5 seconds and verify that the patrol speed reading agrees with the simulated patrol speed during this 5 second period. Repeat this procedure for an initial patrol speed of 40 mph (64 km/h).

(i) Auxiliary Display Tests.

(1) Connect the radar device together with the auxiliary printer or remote display module to the simulator and conduct the display speed lock test (paragraph (b) of this section) and the display clear test (paragraph (c) of this section). Verify that the remote module displays are cleared when it is reconnected to the radar device.

(2) With the radar device still connected to the simulator, establish a simulated target, actuate the speed lock switch and the printer function. Verify that the printout includes the items required by § 1221.21(i).

§ 1221.80 Electromagnetic interference tests.

Connect the radar device to the simulator and to the other test equipment as shown in figure 10. Activate the radar device in the stationary mode, determine the minimum signal level necessary to establish a simulated 50 mph (80 km/h) target, then increase the simulated signal level by 3 dB (1.5 dB if using a microwave attenuator). Turn the simulated signal off and proceed with each of the tests in paragraphs (a) through (d) of this section.

(a) Vehicle Alternator Interference Test.

(1) With the pulse generator connected such that the pulse signals are impressed on the radar device power line, set the generator output to 1 V peak-to-peak, as measured by the oscilloscope, at a pulse repetition rate of 200 pulses per second (pps) with a pulse width of 10-20  $\mu$ secs. With the radar device still in the stationary mode, establish a simulated target of 40 mph (64 km/h) and slowly vary the generator frequency from 200 pps to 10,000 pps and back to 200 pps.

(2) For type II and IV radar devices, switch to the moving mode, turn off the pulse generator, and determine the minimum signal level necessary to establish a patrol speed of 50 mph (80 km/h). Then increase this level by 10 dB

(5dB if using a microwave attenuator). Establish a target speed to 60 mph (96 km/h) (3 dB above a minimum target signal), reset the pulse generator to 1 V peak-to-peak and repeat the procedure in (1) above. Verify that no erroneous readings appear at any time.

(3) Repeat (1) and (2) above using a constant pulse repetition rate of 1500 pps while slowly varying the pulse amplitude from 0 V to 1 V and back to 0 V, as measured at the oscilloscope. Repeat (1) and (2) above using a constant 3100 pps.

(b) Vehicle Ignition, Air Condition/Heater Motor and Windshield Wiper Motor. Disconnect the pulse generator and replace it with the sawtooth as shown in figure 11, such that sawtooth wave signals are impressed on the radar device power line. Place the radar device in the stationary mode, establish a simulated target of 40 mph (64 km/h), then increase the simulated signal level by 3 dB above a minimum target signal. Set the generator output to 1 V peak-to-peak as measured but the oscilloscope at a frequency of 200 Hz. Slowly vary the generator frequency from 200 to 10,000 Hz and back to 200 Hz. Verify that no erroneous readings appear at any time.

For type II and IV radar devices, switch to the moving mode, turn off the sawtooth wave generator and establish a patrol speed of 50 mph (80 km/h) (10 dB above minimum patrol signal) and a target speed of 60 mph (96 km/h). Then increase

the simulated signal level by 3 dB, reset the sawtooth wave generator to 1 V peak-to-peak and repeat the above procedure. Verify that no erroneous readings appear at any time.

(c) Police FM Transceiver Interference Test.

(1) Connect the FM signal generator to the line impedance stabilization network, as shown in figure 12, such that the rf signals are impressed on the radar device power line. Place the radar device in the stationary mode, establish a simulated target of 40 mph (64 km/h), then increase the simulated signal level by 3 dB, set the generator frequency deviation to 5 kHz. Set the generator to a frequency of 160 MHz with an output of 10 mW, as measured by the power meter, with no more than 1 mW reflected power. Slowly vary the modulation frequency from 200 to 10,000 Hz and back to 200 Hz. Verify that no erroneous readings appear at any time.

(2) For type II and IV radar devices, switch to the moving mode, turn off the FM signal generator, establish a patrol speed of 50 mph (80 km/h) (10 dB above minimum patrol signal) and a target speed to 60 mph (96 km/h). Then increase the simulated signal level by 3 dB, turn on the FM signal generator, and repeat the above procedure. Verify that no erroneous readings appear at any time.

(3) Repeat (1) and (2) above using a constant modulation frequency of 1500 Hz while slowly varying the FM signal generator output from 0 to 10 mW and back 0 mW. Repeat (1) and (2) above using a constant modulation frequency to 3100 Hz.

(4) Repeat the entire test for frequencies of 40 and 460 MHz.

(d) Citizens Band (CB) AM Transceiver Interference Tests.

(1) Connect the AM signal generator to the line impedance stabilization network, as shown in figure 12, such that the rf signals are impressed on the radar device power line. Place the radar device in the stationary mode, establish a simulated target of 40 mph (64 km/h), then increase the simulated signal level by 3 dB. Set the generator to a frequency of 27 MHz with an output of 5 mW, as measured by the power meter, with no more than 1 mW reflected power, at a frequency of 27 MHz and adjust the generator modulation to 99%. Slowly vary the modulation frequency from 200 to 10,000 Hz and back to 200 Hz. Verify that no erroneous readings appear at any time.

(2) For type II and IV radar devices, switch to the moving mode, turn off the AM signal generator, establish a patrol speed of 50 mph (80 km/h) (10 dB above minimum patrol signal) and a target speed of 60 mph (96 km/h). Then increase the simulated signal level by 3 dB, turn on the AM signal generator, and repeat the above procedure. Verify that no erroneous readings appear at any time.

(3) Repeat (1) and (2) above using a constant modulation frequency of 1500 Hz while slowly varying the AM signal generator output from 0 to 5 mW and back to 0 mW. Repeat (1) and (2) above using a constant modulation frequency of 3100 Hz.

§ 1221.81 Radar device operational tests.

Install the radar device in the patrol vehicle in accordance with the manufacturers instructions, using extreme care in positioning the antenna. The patrol vehicle shall be of the type normally used for law enforcement purposes, with heavy duty components. It shall have at least one standard police FM transceiver and an antenna installed in accordance with the instructions provided by the transceiver manufacturer. This test must be conducted in an environment free of extraneous moving targets such as large ventilation fans.

(a) Police FM Transceiver Interference Test.

(1) Start the patrol vehicle engine and set it to a fast idle. Wait 30 seconds, place the radar device in the stationary mode and switch on the FM transceiver. Track a just-acquired distant target traveling at a speed of 50 mph (80 km/h), activate the push-to-talk switch and use the slide whistle to transmit tones via the microphone. Slowly vary the tone of the slide whistle from 500 Hz to 3000 Hz and back to 500 Hz, observing the target speed display for possible erroneous readings. Repeat two more times.

(2) Turn off the FM transceiver and repeat the procedure using a handheld FM transceiver with an integral antenna and an output power of 2 watts or more positioned at the patrol vehicle driver's location.

(b) Citizens Band (CB) AM Transceiver Interference Test.

Mount the CB transceiver in a typical front seat location and install the antenna as recommended by the manufacturer. Connect the CB transceiver power leads to the vehicle battery or the ignition switch circuitry, but not to the cigarette lighter. Start the patrol vehicle engine and set it to a fast idle. Place the radar device in the stationary mode and track a just-acquired distant target traveling at a speed of 50 mph (80 km/h). Switch on the CB transceiver, set it to channel 20 activate the push-to-talk switch and use the slide whistle to transmit tones via the microphone. Slowly vary the tone from 500 to 3000 Hz and back to 500 Hz, observing the target speed display for possible erroneous readings. Repeat for channels 1 and 40.

(c) Adjacent Vehicle Radiofrequency Interference Test.

(1) Start the patrol vehicle engine and set it to a fast idle. Place the radar device in the stationary mode and track a just-acquired distant target traveling at a speed of 50 mph (80 km/h). From a distance of at least 50 ft (15 m), slowly drive a second vehicle equipped with a police FM transceiver of at least 50 watts of output power and a matching antenna past the patrol vehicle passing within 10 ft. (3 m) of it. Use the slide whistle to transmit tones between 500 and 3000 Hz from this transceiver until reaching a point 50 ft. (15 m) away from the patrol vehicle. Note any erroneous readings on the radar device



display. Turn the second vehicle around and repeat the above procedure, passing with 10 ft. (3 m) of the patrol vehicle on its other side, again using the slide whistle to transmit modulating tones from 500 to 3000 Hz, and observing the radar speed display.

(2) Turn off the FM transceiver, mount a 4 W minimum output power CB transceiver powered by the vehicle electrical system in the second vehicle and repeat the above procedure.

§ 1221.82 Speed accuracy test.

(a) Establish a measured distance of at least 2640 ft (800 m) on an open, level location away from other moving targets. Turn on the radar device place it in the stationary mode and drive the patrol vehicle over the measured distance at a constant speed, measuring the lapsed time with a stopwatch while recording the patrol speed reading and the speedometer reading. Repeat the procedure twice in each direction, maintaining the same speed for all 4 runs. Use the stopwatch average time to determine the true patrol vehicle speed and use this speed to calculate the patrol vehicle speedometer correction factor and the radar device speed correction factor. Repeat this procedure for speeds of 20, 50 and 70 mph (32, 72, and 96 km/h).

(b) For type II and IV radar devices, switch to the moving mode of operation and repeat this procedure to obtain the appropriate correction factor.

(c) Switch the radar device to the stationary mode of operation and position the radar equipped patrol vehicle near one end of the measured test range. Drive a target vehicle through the measured distance at a constant speed, measuring the elapsed time with a stopwatch, recording the speedometer reading and measuring target vehicle speed with the radar device. Repeat one time, then move the patrol vehicle to the opposite end of the measured range. Repeat the procedure twice in this direction, again recording the stopwatch elapsed time, speedometer reading and radar speed reading. Calculate the true target vehicle speed, the target vehicle speedometer correction factor and the indicated radar speed reading. Repeat this procedure for speeds of 20, 50 and 70 mph (32, 80 and 112 km/h).

(d) For type II and IV radar devices, switch the radar device to the moving mode and station the patrol vehicle and target vehicle at opposite ends of, and the target vehicle beyond the end of, the measured distance. Make 3 moving mode, constant speed, approaching runs in each direction, recording the speedometer readings of each vehicle and the radar device speed display reading. A stopwatch may be used to obtain the true vehicle speed. Average the 6 speedometer and speed display readings. Calculate the true target vehicle speed, the target vehicle correction factor and the indicated radar speed reading. Repeat this procedure using a patrol speed of 20 mph (16 km/h) and a target speed of 55 mph

(88 km/h) and using a patrol speed of 55 mph (88 km/h) and a target speed of 70 mph (112 km/h).

(e) For radar devices with a moving mode, following feature, repeat this procedure using a patrol speed of 55 mph (88 km/h) and a target speed of 70 mph (112 km/h).

Table 1.--Minimum Performance Requirements for Speed  
Measuring Radar Devices

Performance Characteristic	Minimum Requirement
A. Tuning Fork Frequency Tolerance	$\pm 1/2 \%$
B. Radar Device Tuning Fork Speed Tolerance	$\pm 1$ mph ( $\pm 1.6$ km/h)
C. Microwave Frequency Variation	10,500 - 10,550 MHz (X-Band) 24,050 - 24,250 MHz (K-Band)
D. Input Current Variation	10 %
E. Radiated Output Power Variation	$\pm 1.5$ dB
F. Antenna Horizontal Beam Width	18° max (X-Band) 15° max (K-Band)
G. Antenna Near-Field Power Density	As specified by mfr
H. Radar Device Speed Tolerance During Vibration	$\pm 2$ mph ( $\pm 3$ km/h)
I. Low Supply Voltage	10.8 V max
J. Display Readability Contrast	2.5
K. Display Readability Height	.4 in (1 cm)
L. Target Channel Sensitivity, Stationary Mode	$\leq 10$ dB 20 to 90 mph (32 to 144 km/h) $\leq 3$ dB 60 to 90 mph (96 to 144 km/h)
M. Target Channel Sensitivity, Moving Mode	$\leq 10$ dB 40 to 90 mph (64 to 144 km/h) $\leq 3$ dB 60 to 90 mph (96 to 144 km/h)
N. Target Channel Speed Displays	20 mph (32 km/h) max low speed 100 mph (160 km/h) min high speed
O. Patrol Channel Speed Displays	20 mph (32 km/h) max low speed 55 mph (88 km/h) min high speed
P. Patrol Channel Speed Changes	$\pm 1$ mph (1.6 km/h) for $\geq 3$ mph (4.8 km/h) per sec
Q. Accuracy, Stationary Mode	$\pm 1$ mph ( $\pm 1.6$ km/h)
R. Accuracy, Moving Mode	$\pm 2$ mph ( $\pm 3$ km/h)

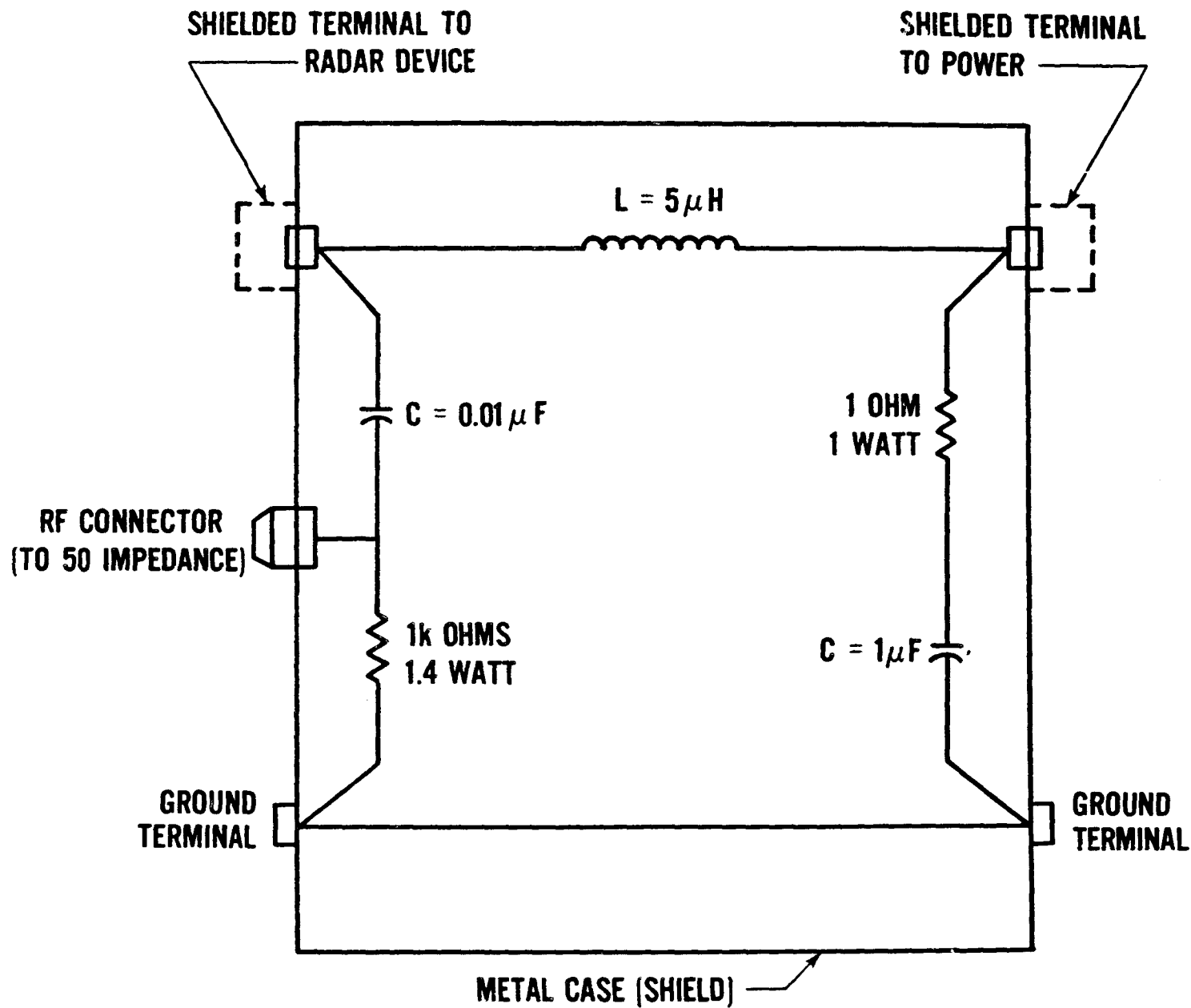

-74-

Figure No. 1  
Line impedance stabilization network (LISN).

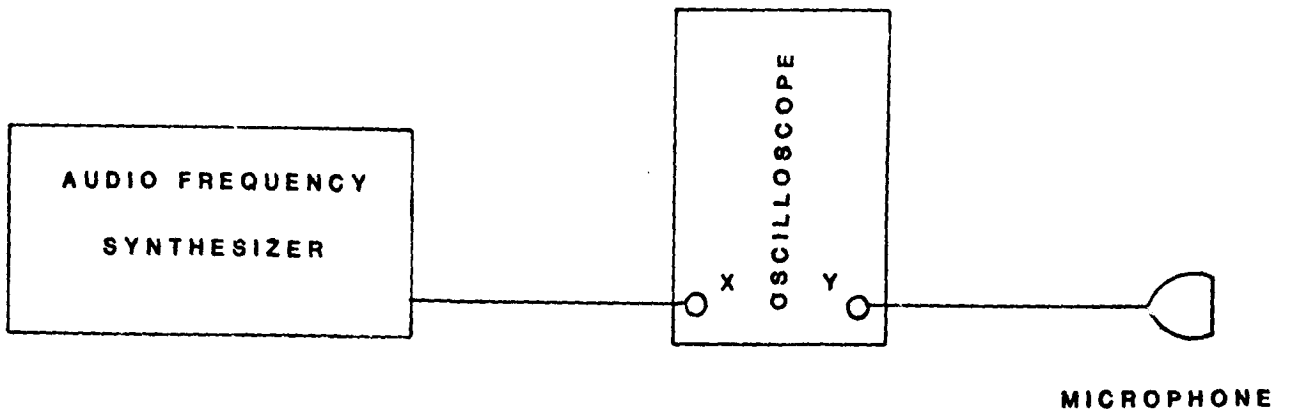

Figure No. 2

Block diagram for tuning fork calibration measurement.

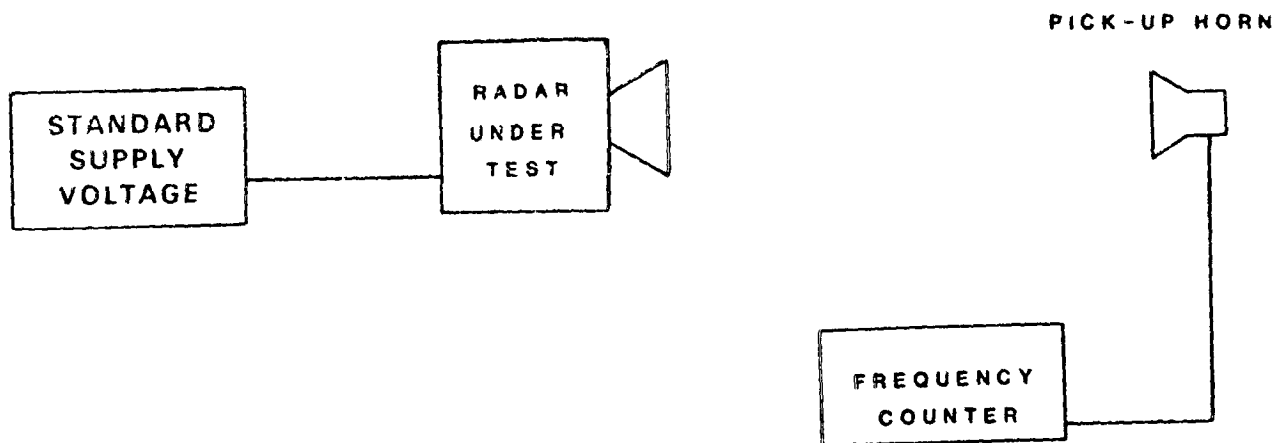
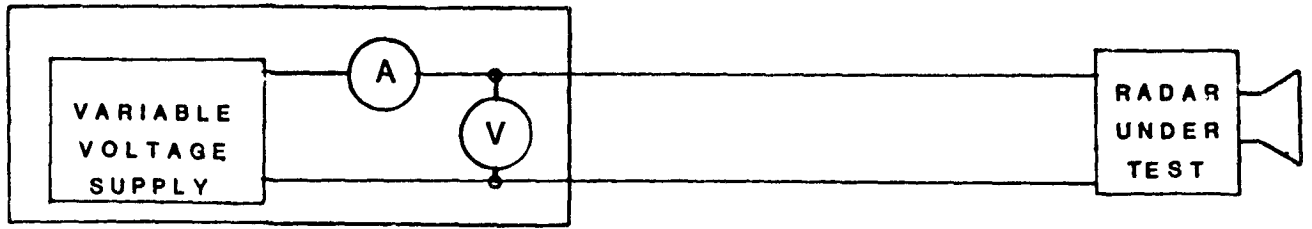

Figure No. 3

Block diagram for transmission frequency and frequency stability measurements.



STANDARD SUPPLY VOLTAGE

Figure No. 4  
Block diagram for input current, low supply voltage  
and power surge measurements.

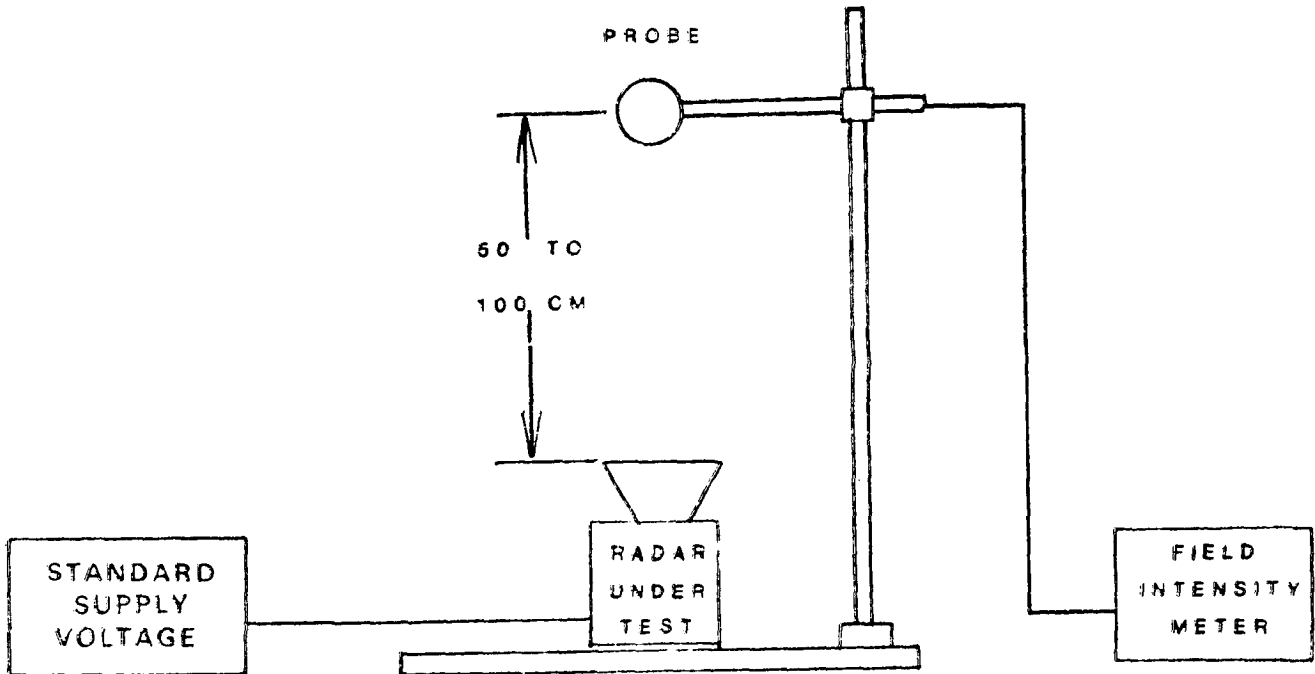
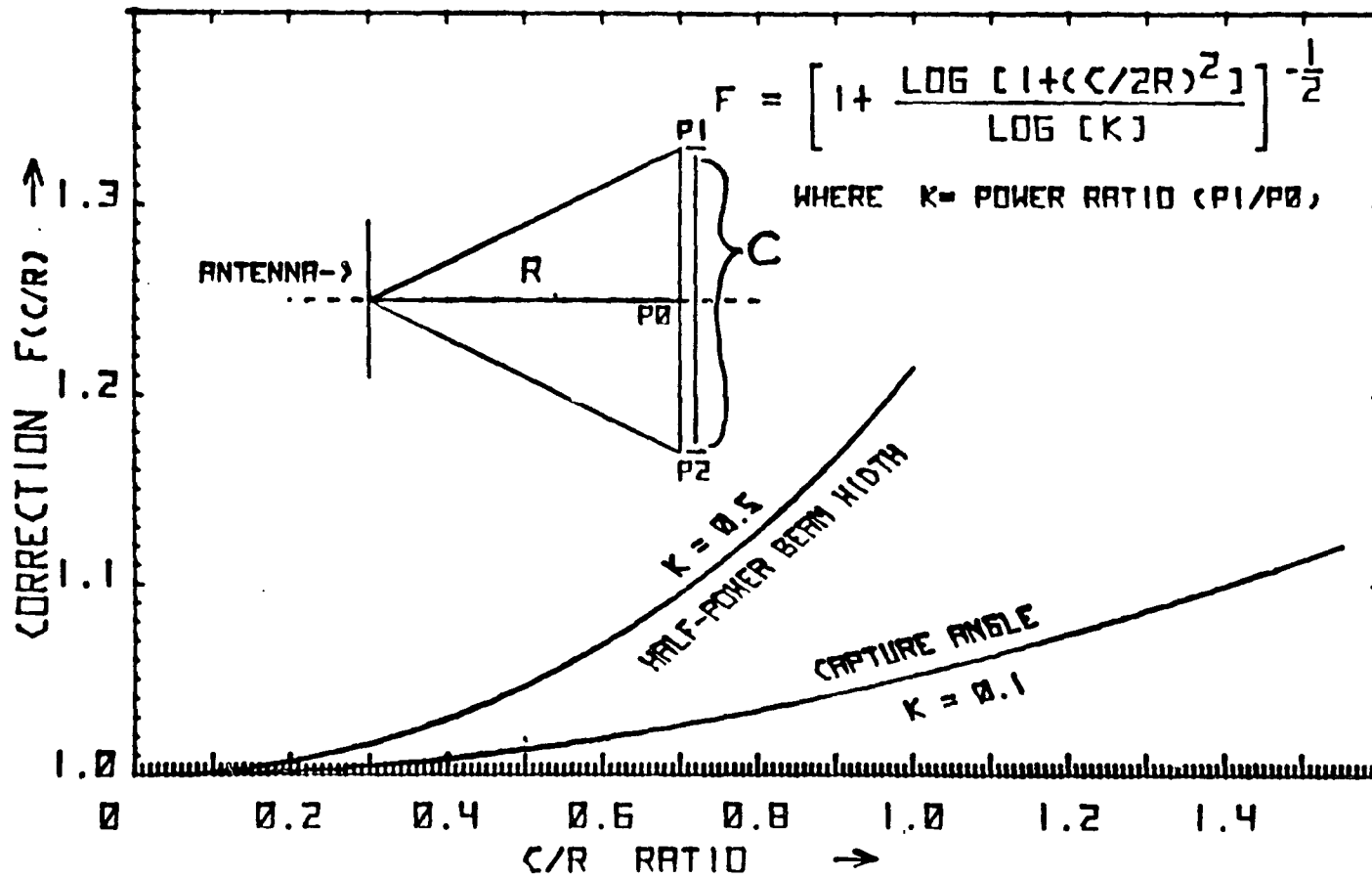

Figure No. 5  
Block diagram for antenna beam width measurement.

BEAM ANGLE:  $\theta = 2 \cdot F(c/R) \cdot \text{ARCTAN}(C/2R)$



-77-

Figure No. 6  
Antenna beam width correction factor,  $f^\circ$ .



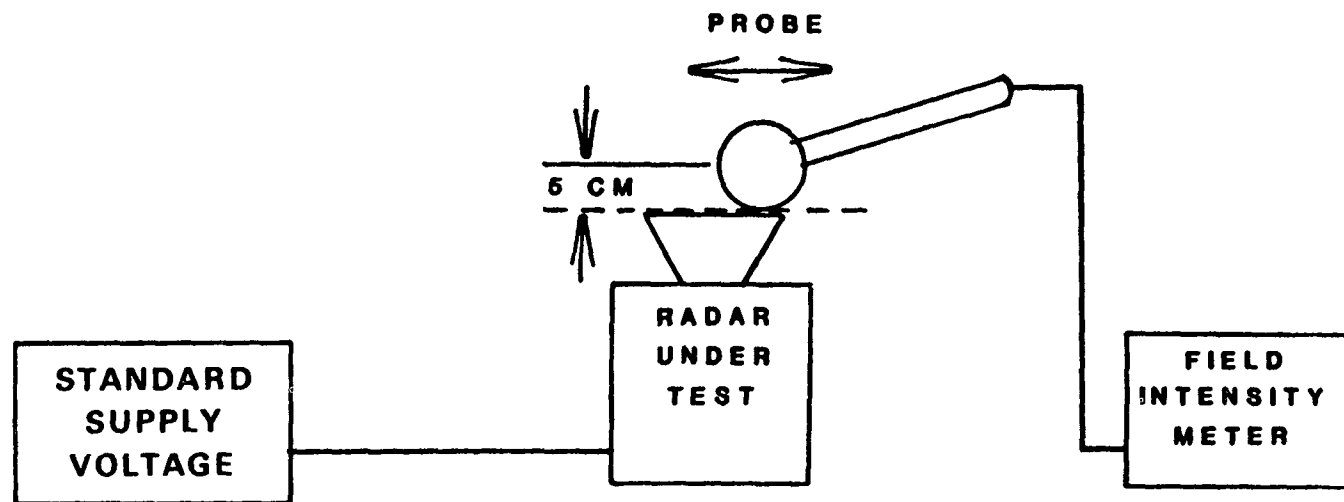

Figure No. 7

Block diagram for the antenna near-field power density measurement.

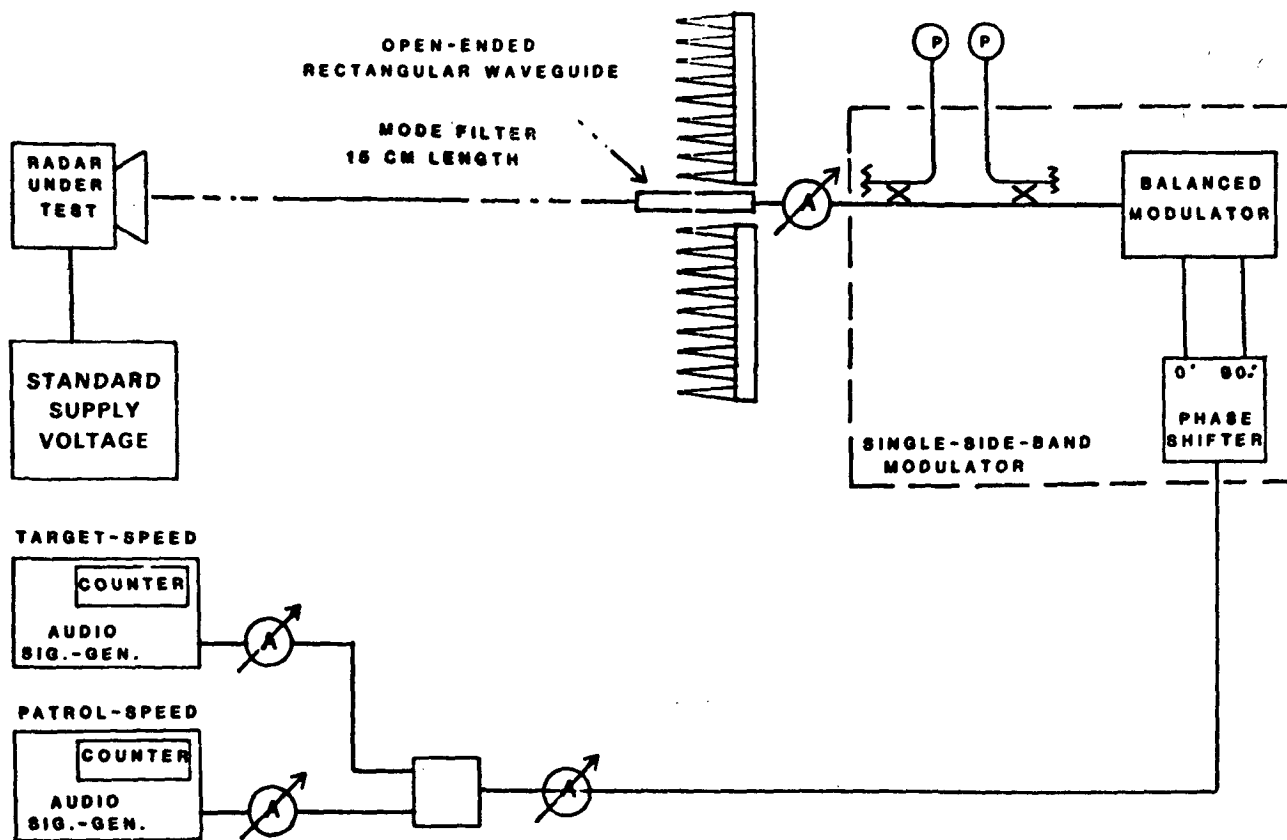

Figure No. 8

Block diagram for the simulator test range used in the doppler audio, power surge, speed display and electromagnetic interference measurements.

- A- WAVEGUIDE MAGIC-TEE
- B- WAVEGUIDE TERMINATION
- C- TUNABLE DIODE DETECTORS

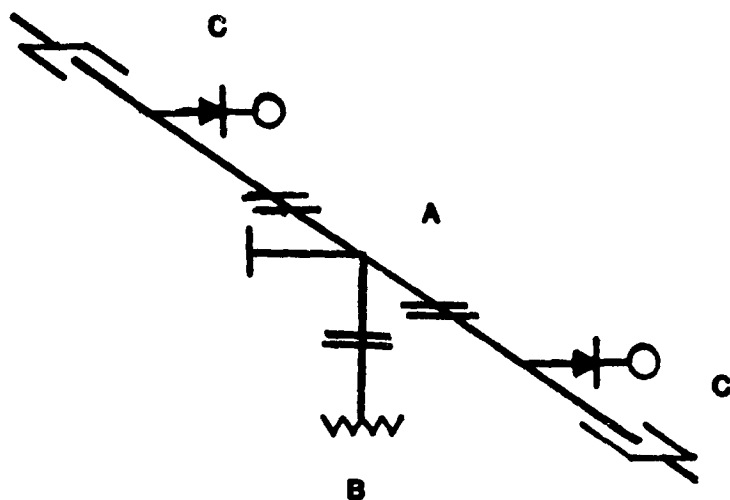
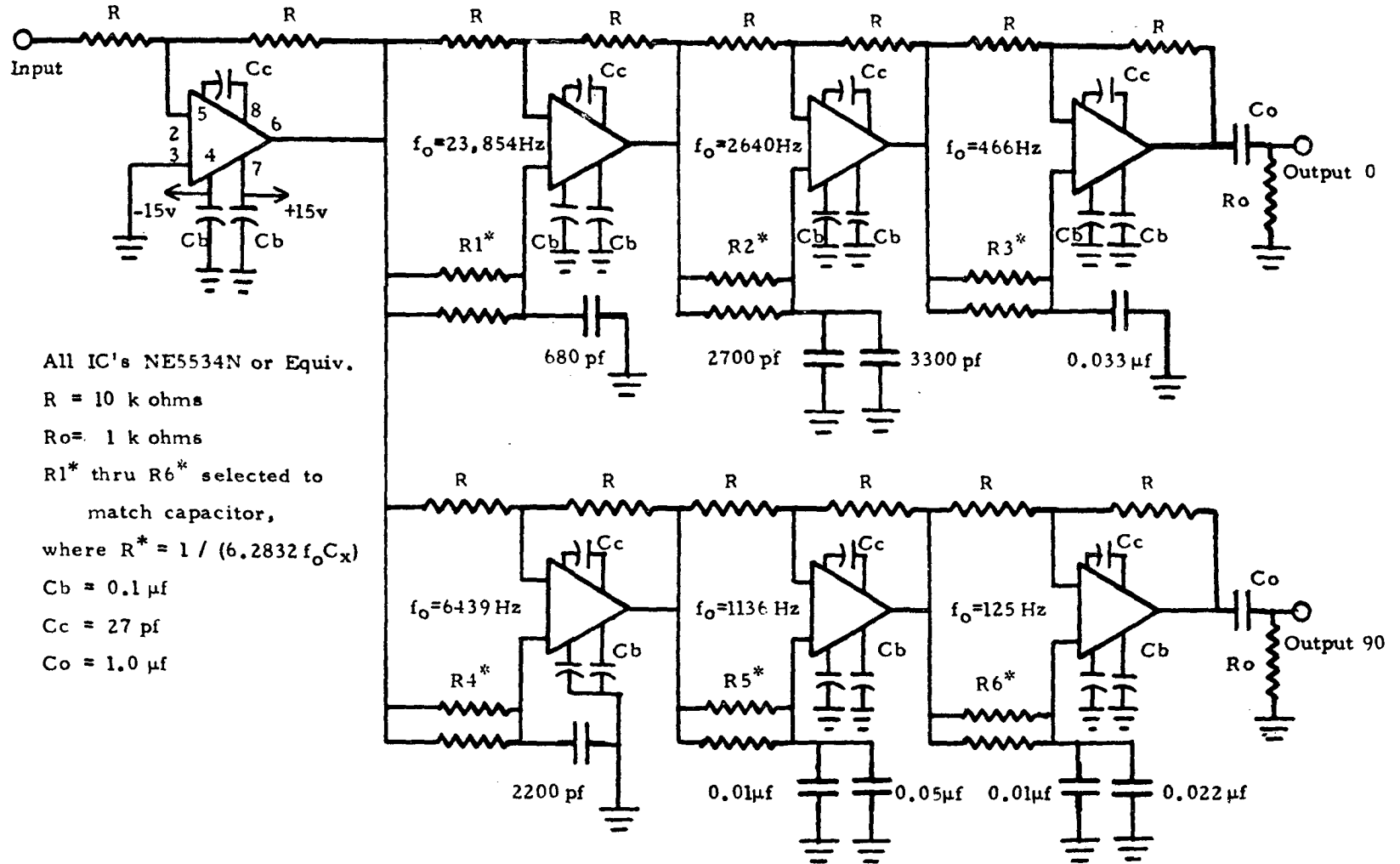

Figure No. 8a

Schematic of balanced modulator shown in Figure 8.

ALL-PASS 90 DEGREE PHASE-SHIFTER

300 Hz to 10,000 Hz



All IC's NE5534N or Equiv.

R = 10 k ohms

Ro = 1 k ohms

R1\* thru R6\* selected to match capacitor,

where  $R^* = 1 / (6.2832 f_o C_x)$

Cb = 0.1  $\mu$ f

Cc = 27 pf

Co = 1.0  $\mu$ f

Figure No. 8b

Schematic of 0-90° phase shifter shown in Figure 8.

**FACE OF DISPLAY**

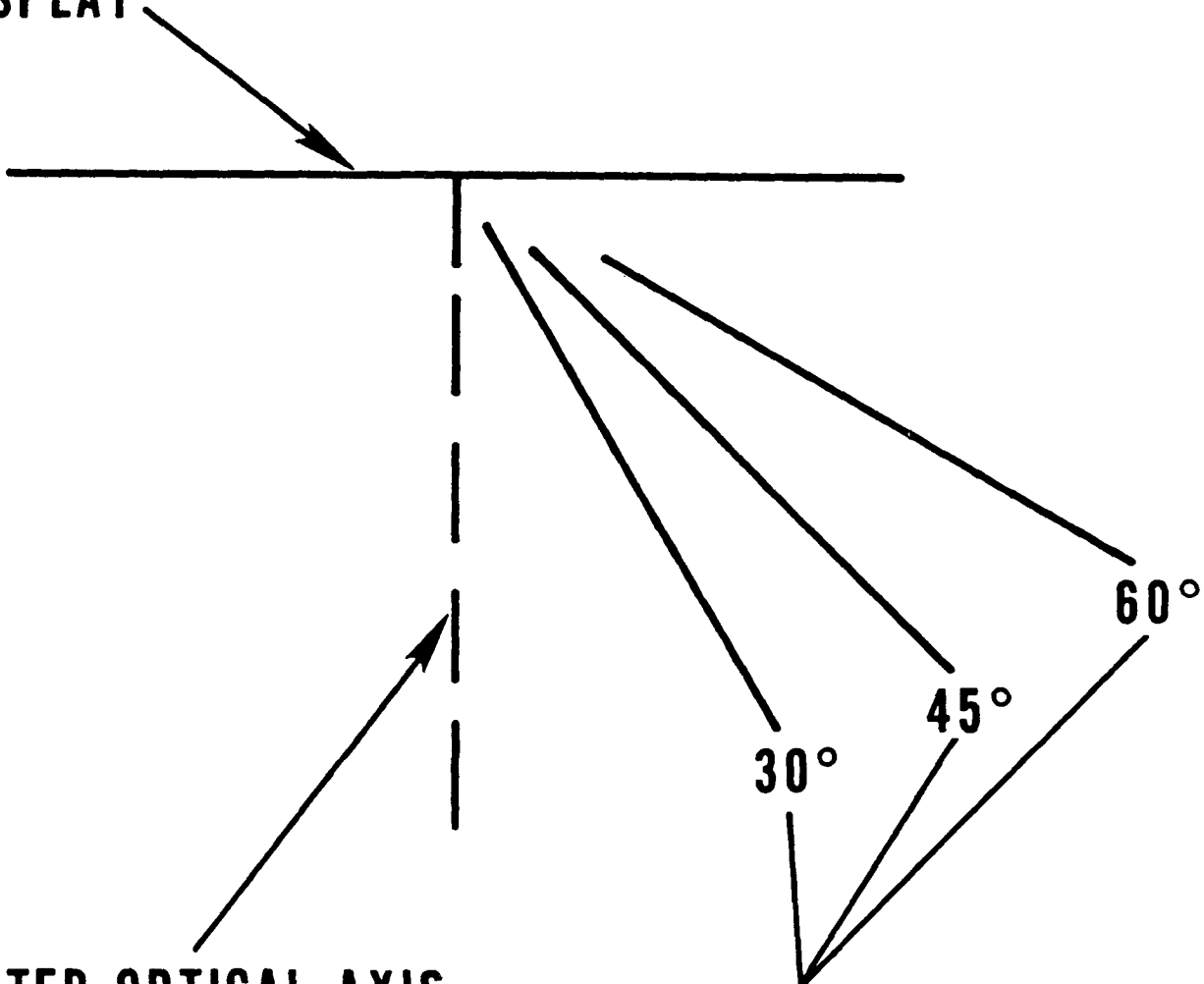

**PHOTOMETER OPTICAL AXIS**

**POSITIONS OF ILLUMINATION**

Figure No. 9

Block diagram for display readability measurements.

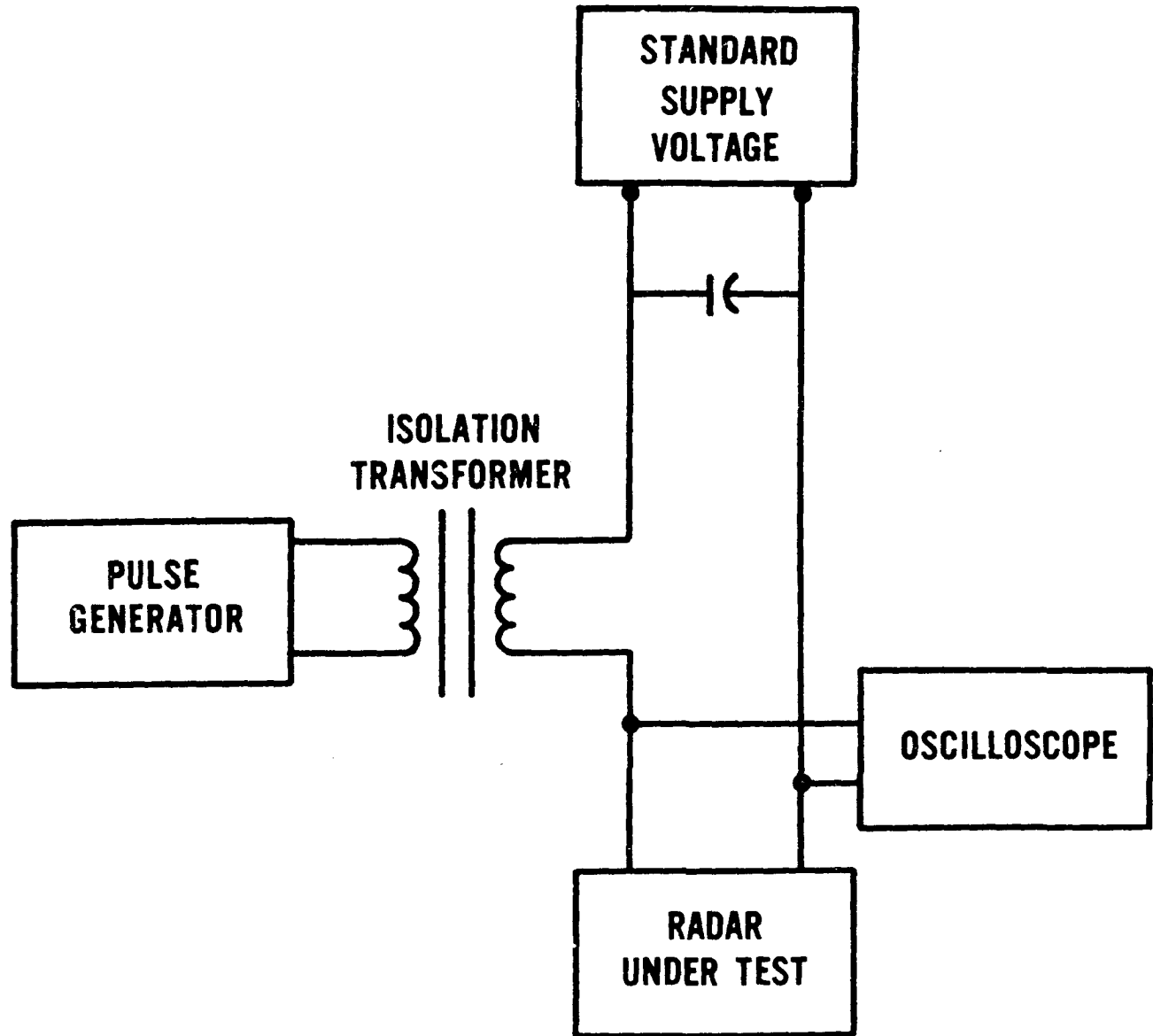

Figure No. 10  
Block diagram for the simulated vehicle  
alternator interference measurement.

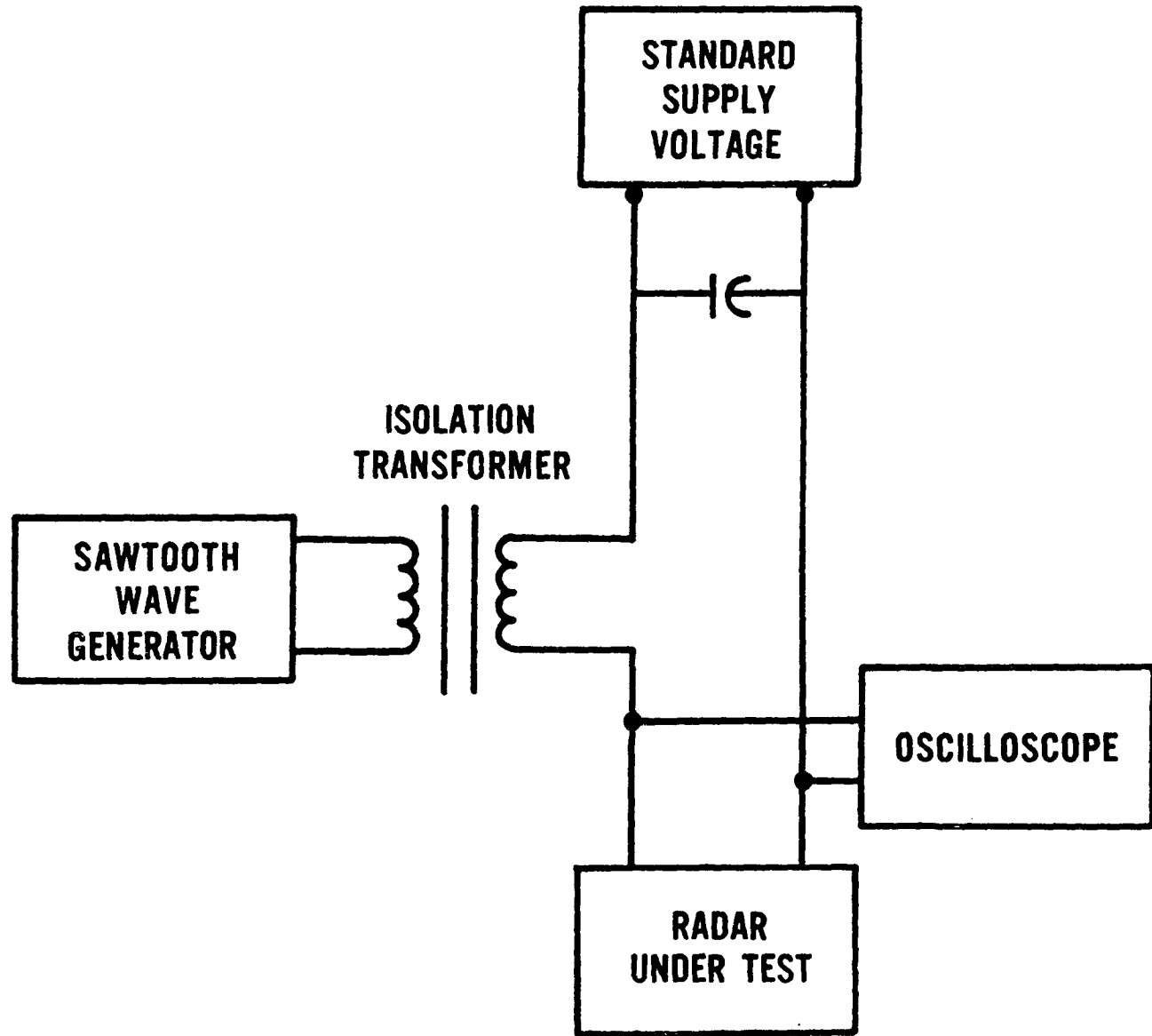
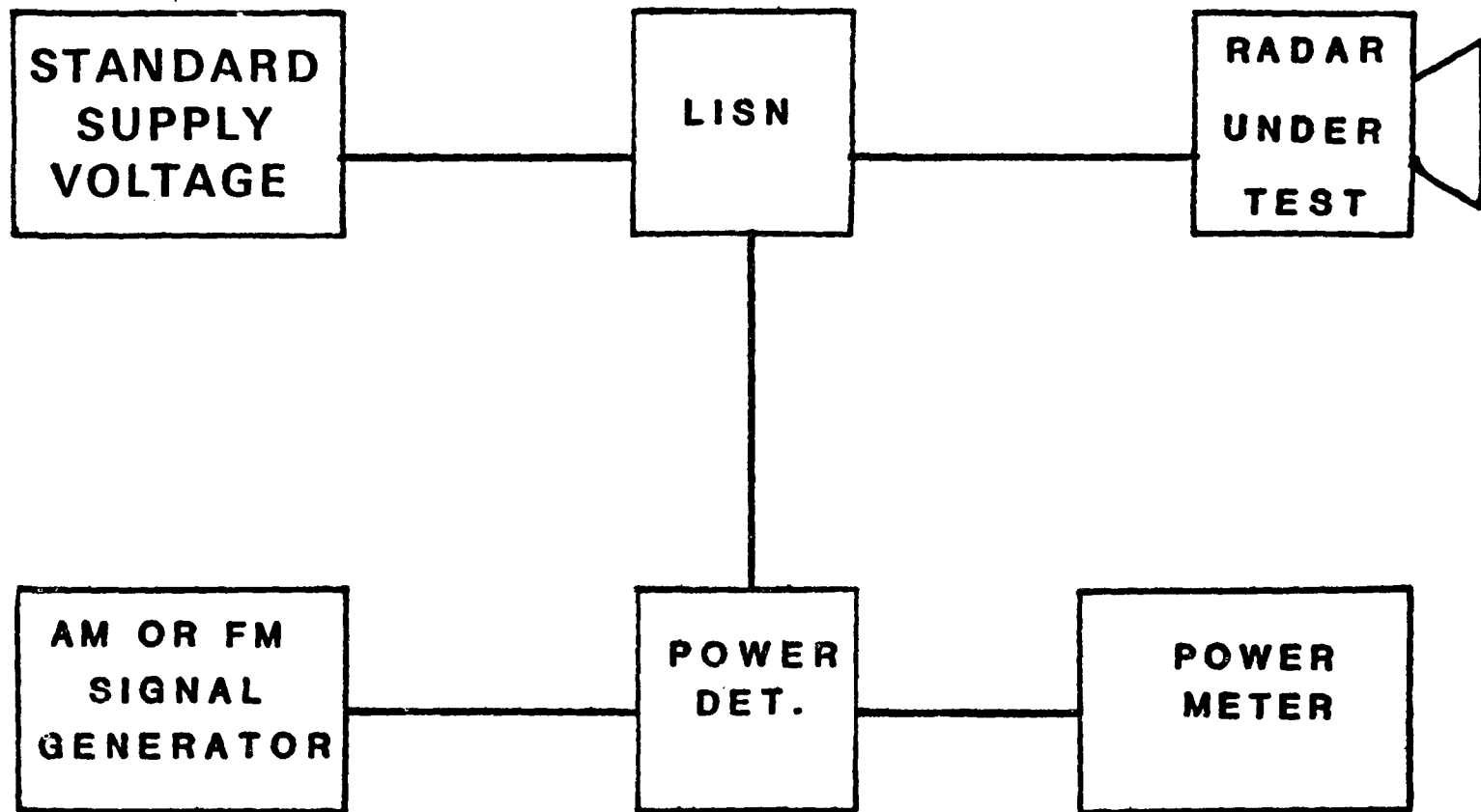

Figure No. 11

Block diagram for the simulated vehicle ignition, air conditioner/heater and windshield wiper interference measurements.



-84-

Figure No. 12

Block diagram for the simulated police FM transceiver and the citizens band AM transceiver interference measurements.

## BIBLIOGRAPHY

1. Allen, D. W. and Brzoticky, F. H., Calibration of Police Radar Instruments, NBS SP-442, Report of the 60th National Conference on Weights and Measurements, 1975, pp. 42-47, (May 1972).
2. Federal Communications Commission, Rules and Regulations, Part 90, Subpart F.
3. Federal Communications Commission, Bulletin OCE 37, Criteria to be Met by Doppler Radars Operating in the 24.05-24.05 GHz Frequency Band, (Revised may 1979).
4. SAE Recommended Practice J1113A, Electromagnetic Susceptibility Procedures for Vehicle Components, (Revised June 1978).
5. NDS Nomograph 92, Radio Metrology, pages 102-103, (March 1966).
6. 90° Phase Shifter, 300-10,000 Hz, Electronic Design, p. 90 (September 13, 1976).
7. American National Standard for Temperature Measuring Thermocouples, ANSI MC96.1-1975.
8. ANSI/ASTM E 230-77, Standard Temperature - Electromotive Force (EMF) Tables for Thermocouples.



**APPENDIX A**

**Michigan Radar Task Force Performance Standards  
for Existing Speed Measuring Radar Devices**

**September 15, 1981**

Speed measuring devices currently in use by law enforcement agencies in the State of Michigan are for the most part, accurate, useful, and reliable tools in the hands of properly trained operators. The primary intent of new device performance standards and new operator training programs is to decrease the level of skill needed for the proper use of radar devices while simultaneously increasing the level of skill of officers who use them. This is to ensure that radar retains its acceptance as an essential law enforcement tool. A secondary, yet important, intent of the new device performance standards is to ensure a reasonable useful life for these devices, ease of maintenance, and reasonable mean-time-between-device failure under normal storage and operating conditions.

Two years of extensive laboratory and field testing has determined that radar speed measuring devices presently in service by law enforcement agencies in the State of Michigan can be operated reliably by properly trained personnel provided the following two features are not present:

1. A mechanism for automatically locking a target speed in the display, i.e., autolock;
2. A mechanism such as an audible tone and/or momentary locking of the display for warning operators that a displayed target is exceeding a present speed threshold, i.e., violator warning.

and provided the following two features are present:

1. A minimum of two display windows for moving-mode radar so that the patrol speed and target may be displayed simultaneously.
2. A doppler audio signal channel which gives the operator a tone that directly correlates with the displayed target's speed.

Existing equipment shall either be qualified to override the two undesirable features or they shall be taken out of service. Radar devices which do not possess the doppler audio feature, shall either have this feature added or shall be taken out of service by October 1, 1983. (NOTE: A deadline of October 1, 1983, has been set for either adding the doppler audio feature or for taking devices out of services which do not possess the doppler audio feature. This two-year period is given because of the expense required to add the audio feature, approximately \$300 per unit. Without the audio feature, operators will have to be very selective in terms of roadway and traffic conditions for which such a radar device is used.) And, finally a moving-mode radar device which possess only one display window shall either be modified to operate only in the stationary mode or it shall be taken out of service.

Summary: This notice establishes minimum performance requirements for the procurement of speed measuring radar devices that will be used by law enforcement agencies in the State of Michigan. The intent of this standard is twofold: First, the standard specifies critical operational capabilities and features of speed measuring radar devices so as to ensure that a properly trained operator can use these devices reliably on Michigan roadways; and this will enable radar to retain its acceptance as an essential law enforcement tool. Second, the standard specifies that the parts and overall construction of these devices are such as to ensure reasonable useful life for these devices, ease of maintenance, and reasonable mean-time-between-device-failure under normal storage and operating conditions. (NOTE: As of the date of this document, NHTSA has developed, but not yet enacted, a regulation dealing with performance requirements and test methods for evaluating speed measuring radar devices. Once enacted, this Federal regulation will supercede the Michigan Radar Task Force Performance Standards for New Speed Measuring Radar Devices.)

Performance Standards:

1. Devices may be one-piece or two-piece construction. One-piece devices with moving-mode capability must possess a suitable mounting bracket to secure the unit for moving-mode operation. Two-piece devices must possess a suitable antenna mounting bracket and suitable hardware for securing the display module to this antenna bracket or to some other fixture within the patrol vehicle.
2. The minimum display range for the target channel shall be 15 mph to 129 mph for both stationary and moving-mode radar.
3. The minimum display range for the patrol channel for moving-mode radar shall be 15 mph to 79 mph.
4. When the radar device is operated in either the stationary or moving-mode, its target channel signal processing sensitivity shall not vary by more than 10 db for targets traveling at speeds between 15 mph to 129 mph nor more than 3 dB for targets traveling between speeds of 60 mph to 90 mph. (NOTE: For moving-mode radar, this requirement holds for all patrol vehicle speeds on the range 15 mph to 79 mph, but it is understood that there is an exception for target speeds within +1 mph of the patrol speed since notch filter characteristics may cause the target channel signal processing sensitivity to drop below 10 dB.)
5. The minimum temperature range shall be -22<sup>0</sup>F to +140<sup>0</sup>F.
6. The minimum operating voltage range shall be 10.8 V to 15 V.
7. Over the entire range of target speeds, patrol speeds, operating temperatures, and operating voltages, the accuracy of the target channel display shall be +1 mph for stationary-mode operation and +2 mph for moving-mode operation, and the accuracy of the patrol display shall be +1 mph.

8. No fixed part of the radar device shall come loose, nor movable part be shifted in position or adjustment, as a result of the following vibration test for each orientation of the device: First subject the radar device to three 5 minute cycles of simple harmonic motion having total excursion of 0.03 in applied initially to 10 Hz at a minimum rate to 30 Hz in 2.5 minutes, then reduced to 10 Hz at a uniform rate in 2.5 minutes. Then repeat the above test for the frequency range 30 Hz to 60 Hz for a total excursion of 0.015 in.
9. The device shall possess the following features:
  - a. a light segment test;
  - b. an internal counter test;
  - c. a doppler audio output whose tones shall be clear and in a frequency range that makes it useful to an operator for the full minimum ranges of target and patrol speeds;
  - d. a volume control for the doppler audio channel;
  - e. a squelch feature such that no audio output is present when a target speed is not being displayed and a manually activated squelch override feature;
  - f. a mechanism which warns the operator that rf interference is present and also automatically blanks the display before erroneous target display readings occur due to this interference;
  - g. a mechanism which warns the operator that low-voltage condition exists and also automatically blanks the display before erroneous target readings occur due to this condition;
  - h. a power cable which is hardwired to the radar device and fitted at the other end with a male cigar type plug, "Safco No. 20" or an approved alternate;
  - i. a power line fuse and appropriate over-voltage protection;
  - j. a range control which has a variable control capable of providing an approximate linear response (zero to maximum) over the full range of settings;
  - k. a minimum of two display windows for moving-mode radar to display patrol speeds and target speeds simultaneously.
10. The device shall not possess the following features:
  - a. a mechanism for automatically locking a target speed in the display, i.e., AUTOLOCK;
  - b. a mechanism such as an audible tone and/or momentary locking of the display for warning operators that a displayed target is exceeding a present speed threshold, i.e., VIOLATOR WARNING;
11. Each radar device shall be accompanied by the following items:
  - a. a simple tuning fork for stationary-mode and two tuning forks for moving-mode radar. (NOTE: these tuning forks shall be properly labeled with speed information, identified for X-band or K-band radar devices, possess a serial number, and be accompanied by a certificate of accuracy.);
  - b. an operator's manual;

- c. a statement that the radar device complies with all appropriate Federal regulations;
  - d. appropriate mounting brackets for the antenna and display module.
12. Radar devices shall be appropriate to the patrol vehicle used and the nature of the roadways on which the device are operated. (NOTE: Agencies procuring radar devices should set forth in their Request for Quotations the types of roadways that the radar devices will be used on--one-way city traffic, two-way city traffic, two-lane highway traffic, multiple-lane undivided highway traffic, and multiple-lane divided highway traffic, and the type of patrol vehicle(s) in which the devices will be used.)
13. The device shall be of rugged construction and reasonably resistant to moisture and other forms of contamination that might affect the device's performance or rate of repair, and labels, connectors, switches, and dials shall be durable for the reasonable life of the device. Moreover, the device shall be capable of being maintained at a reasonable cost.

## Appendix

### Sample Request for Quotation for Measuring Radar Devices

The purpose of this appendix is to assist law enforcement agencies in the State of Michigan in the preparation of a "Request for Quotation" for speed measuring radar devices. Although a particular agency may have a special reason for specifying X-band or K-band radar, two years of laboratory and field testing have failed to determine that one type is superior to the other. Basic device engineering and device quality control appear to be the keys to overall performance. Several options are possible and are indicated next. Also, agencies should state in the preamble to their Request for Quotation the nature of the roadways that the devices will be used on, as well as the type of patrol vehicles used.

Sample  
Request for Quotation

<u>Quantity</u>	<u>Unit</u>	Commodity No.	<u>"Speed Measuring Radar Devices"</u>	<u>Unit</u> <u>Price</u>	<u>Amount</u>
-----------------	-------------	------------------	----------------------------------------	-----------------------------	---------------

Two Piece With Moving & Stationary Modes  
Please indicate X \_\_\_\_\_ or K \_\_\_\_\_ Band.  
One Piece, Hand Held With Moving & Stationary  
Mode--Please indicate X \_\_\_\_\_ or K \_\_\_\_\_  
Band.  
One Piece, Hand Held Stationary Mode Only  
Please indicate X \_\_\_\_\_ or K \_\_\_\_\_ Band.

Speed measuring radar devices must conform to the Michigan Radar Task Force's Performance Standards for New Speed Measuring Radar Devices--September 15, 1981, and to all prevailing Federal requirements. The following additions and exceptions must be considered by bidders and adhered to. Each bidder must indicate in detail any exceptions that his product fails to comply with.

1. Radar units of two piece construction shall have a connecting cable of three (3) feet in length.
2. Power cables shall be three (3) feet in length, one end hardwired to the radar device, the other end shall be fitted with a male cigar type plug, "Safco No. 20" or approved alternate.
3. The antenna mount for moving-mode radar devices shall be an inside vehicle type, close to windshield giving minimum obstruction to the driver's visibility and minimum mechanical interference with driver. The mounts for two-piece radar units shall hold the read-out module and antenna securely so they will not be dislodged during normal patrol car maneuvers.
4. The display module shall be of a light color non-glare finish with a padded protective cover. There shall be no exposed sharp edges or corners.

Hand held units shall also be of a light color non-glare finish.

<u>Quantity</u>	<u>Unit</u>	Commodity No.	<u>"Speed Measuring Radar Devices"</u>	<u>Unit Price</u>	<u>Amount</u>
-----------------	-------------	------------------	----------------------------------------	-----------------------	---------------

5. Options: Please quote separate cost for items A-F.

A. Manual display speed lock \$ \_\_\_\_\_

B. Auxiliary speed display \$ \_\_\_\_\_

C. PF stand-by mode switch, activated by an on-off toggle switch on a three (3) foot cable \$ \_\_\_\_\_

D. Service manuals, to include complete schematics, printed circuit layout prints, parts lists, and explanation of the technical theory of operation. \$ \_\_\_\_\_

E. Luggage type carrying case \$ \_\_\_\_\_

F. Alternate power source (battery) complete with shoulder strap, and charger \$ \_\_\_\_\_

6. The unit shall be fully warranted against all defects in materials and/or workmanship for one year. All parts and labor will be furnished by the manufacturer.

On or before bid opening date, one (1) unit (Production Model of each type) complete with mounting brackets shall be provided along with all other material required. This unit may be subjected to field and laboratory examination and testing to ensure it conforms with bid requirements. Devices which fail to meet bid requirements will be returned at the bidders expense.



APPENDIX B

## FIELD STRENGTH MEASUREMENTS OF SPEED MEASURING RADAR UNITS

R. C. Baird, R. K. Lewis, D. P. Kremer, S. B. Kilgore\*

National Bureau of Standards  
Washington, DC 20234

The objective of this project was to measure the microwave radiation emitted by speed measuring radar units to obtain a data base for evaluating the potential radiation hazards of these devices. Measurements were taken both in free-space and with the radar units mounted in typical operating positions inside or attached to a four-door sedan. The free-space measurements were made at four different distances to determine the field strength as a function of distance from the radar units. Calibrated radiation level probes were used to measure the field strength inside the automobile and scan the interior volume of the four-door sedan with particular attention to the driver and passenger locations. Twenty-two radar units were involved, and the data are presented in a power density format.

Key words: Doppler radar; field intensity; hazard; microwave radiation; power density; radar unit; radiation level; speed measuring radar.

### 1. INTRODUCTION

The objective of this project was to accurately measure the microwave radiation emitted by speed measuring radar units in order to obtain a data base for evaluating the potential radiation hazards of such devices. To meet this objective, the following two measurement tasks were undertaken.

Task 1. Free-Space Measurements: Direct measurements of the field strength levels surrounding 20 different radar units were made in the laboratory under approximate free-space conditions. In order to obtain data in the side- and back-lobe regions as well as in the direction of the main beam, measurements were made at selected points on an imaginary spherical surface centered at the aperture of the radar unit. Further, measurements were made at several distances in order to determine the field strength as a function of distance from the radar units.

Task 2. Vehicular Measurements: The radar units were mounted inside or attached to a four-door sedan in normal operational configurations. Calibrated radiation level probes were used to measure the field strength inside the automobile and to scan the entire interior volume of the vehicle, with particular attention to the driver and passenger locations. This task provided data on field strengths inside the automobile under simulated operating conditions.

---

\*Electromagnetic Fields Division, Center for Electronics and Electrical Engineering.

## 2. TASK 1 MEASUREMENTS

### 2.1 General Approach

The purpose of this task was to measure the field intensity in the region surrounding each radar unit and to determine and display the power density as a function of direction and distance from the radar. The measurements were performed at the National Bureau of Standards (NBS) near-field scanning facility employing standard antenna measurement techniques.

The experimental arrangement and coordinate system are shown in figure 1. The radar was mounted on a model mount aimed at a small receiving antenna (probe), and aligned so that the aperture was in the x-y plane and the direction of the main beam was along the z-axis which coincided with the axis of the receiving probe. The radar was then rotated (scanned) a full  $360^\circ$  about the y-axis ( $\theta$  rotation) and the received signal was recorded at  $5^\circ$  intervals in  $\theta$ . Next, the radar was rotated by  $10^\circ$  about its own axis ( $\phi$  rotation) and the  $\theta$  scan was repeated. (Note that, as shown in figure 1, the  $\phi$ -rotation axis coincides with the z axis for  $\theta=0$ .) This process of stepping in  $\phi$  and scanning in  $\theta$  was repeated until data had been obtained over the entire measurement sphere enclosing the radar. The complete process was repeated for several separation distances,  $d$ .

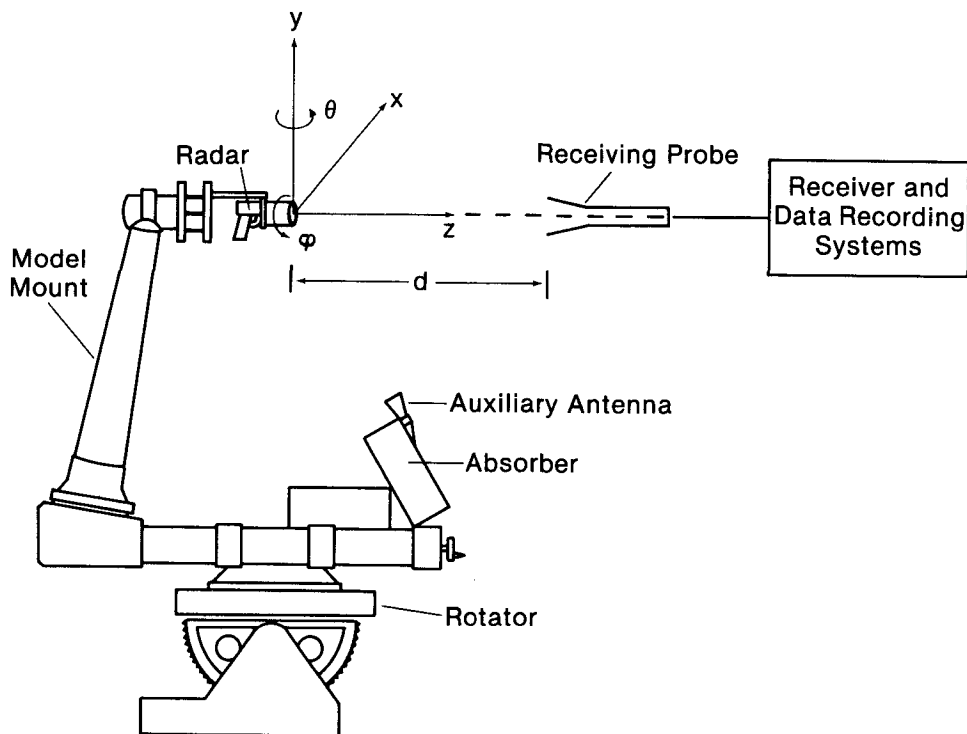

Figure 1. Experimental setup used for measuring electromagnetic field strength in the vicinity of speed radar units.

The received power,  $P_R$ , picked up by the probe was determined by means of a calibrated receiving system. The power density,  $W$ , incident on the receiving probe, was determined from the relation

$$W = \frac{4\pi P_R}{\lambda^2 G} \quad (1)$$

In this equation,  $G$  is the gain of the probe and  $\lambda$  is the free-space wavelength of the energy emitted by the radar unit [1]<sup>1</sup>.

## 2.2 Description of Measurement System

The measurement system is shown schematically in figure 2 as connected for power-density measurements. The signal generator, rotary-vane attenuator (RVA), thermistor, and power meter were only used in the calibration process to be described later. The rest of the system functioned as follows. The electromagnetic (EM) field emitted by the radar was sampled by a small probe antenna. The probe output signal was detected in the mixer and amplified and measured in the receiver. Finally, the amplitude was digitized and recorded on magnetic tape for later computer processing. A coaxial mixer was used for the X-Band measurements and a waveguide mixer was used at K-Band. The receiver used was a calibrated, three-channel, wide-band, phase-amplitude model.

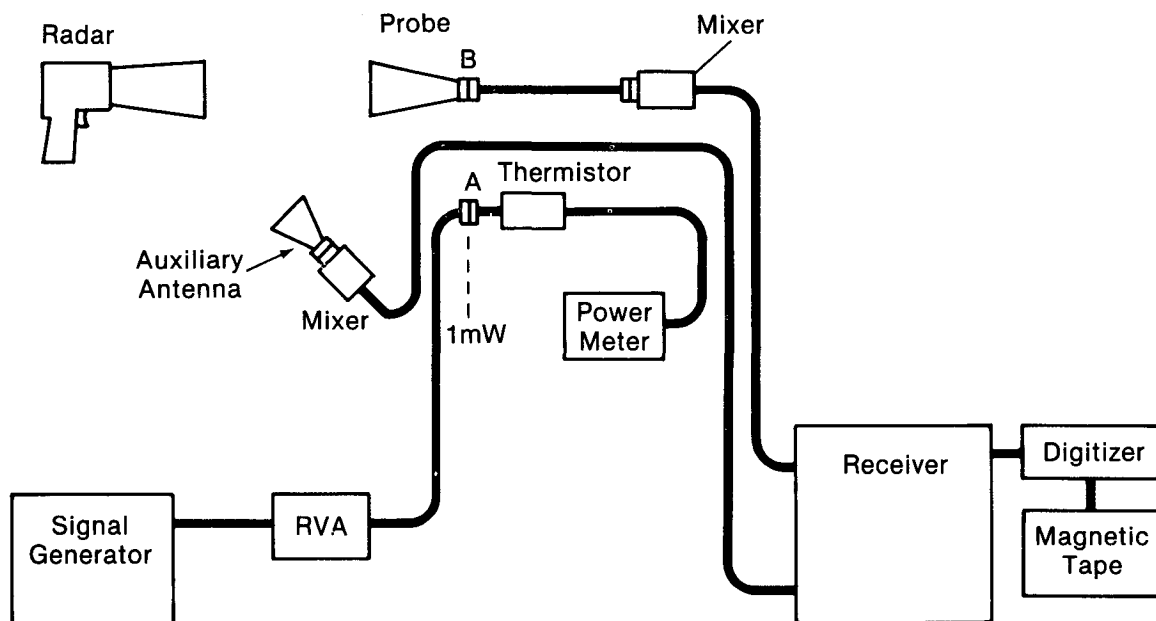

Figure 2. Schematic diagram of measurement system used to determine power density. As shown here, the system is connected for measuring the probe output produced by an incident electromagnetic field. The auxiliary antenna and circuit provide a stable reference signal to which the receiver is phase locked. A 1 mW calibrating signal is established at point A by means of the calibrated thermistor, power meter, and rotary-vane attenuator (RVA).

<sup>1</sup>Numbers in brackets refer to references in appendix A.

In order for the receiver to have sufficient sensitivity to detect the weak signals existing in the side- and back-lobe regions, it must be phase locked to the radar. Since it was not feasible to connect a cable to the radar, the phase-lock signal was provided by means of an auxiliary antenna and mixer which responded to the side-lobe energy radiated by the radar and provided a constant signal for phase locking the receiver. Note that the auxiliary antenna and mixer were mounted on the rotator (fig. 1) so that, as the radar was rotated in azimuth ( $\theta$ ), the relative positions of the radar and auxiliary antenna remained unchanged and the phase-lock signal remained constant within +1.0 dB. As the radar was rotated in  $\phi$ , changes of as much as +3 dB in the amplitude of the phase-lock signals were observed, due mainly to the change in polarization. However, the receiver remained locked during these changes and, since the data were recorded only during  $\theta$  scans with constant  $\phi$ , these changes of amplitude in the locking signal were of no consequence. The auxiliary antenna was mounted below the probe and well out of the main beam, so there was no significant interaction between them; that is, the auxiliary antenna did not noticeably perturb the field measured by the probe.

The auxiliary antenna used for the X-Band measurements was a broadband conical spiral with Type N connector and it was connected to a coaxial mixer. The K-Band auxiliary system consisted of a standard gain horn and waveguide mixer.

## 2.3 Calibration of Measurement System

### 2.3.1 Calibration Procedure

Absolute calibration of the power density measurement equipment was accomplished by means of the signal generator, attenuator, thermistor, and power meter of figure 2. The signal generator provided a calibrating signal of constant amplitude and frequency. The power of this signal at point A was measured by the calibrated thermistor and power meter combination, and accurate changes in this power level were accomplished by means of the RVA. The procedure for carrying out the calibration was as follows.

The radar was set at  $\theta=0$  and  $\phi=0$ , in which case the probe measures the power in the main beam and the probe output signal was near a maximum for that distance. Under these conditions the receiver amplitude was set at 00.00 dB. Next, the signal generator frequency was set equal to the radar frequency and, with the RVA set at 0 dB, the signal generator amplitude was adjusted so that the power meter indicated 1 mW. This means that 1 mW of power was available at A if the thermistor and power meter had been calibrated correctly and all mismatch effects taken into consideration.

The next step was to disconnect the auxiliary mixer from the auxiliary antenna and connect the mixer to the signal generator as shown in figure 3. This link provided the required phase-lock signal for the receiver. The transmission line connecting the RVA to the thermistor was disconnected at A and connected to the primary mixer at B in place of the probe (see fig. 3). Following these connections, the RVA was adjusted until the receiver again read approximately 00.00 dB. The attenuator reading was noted, along with the offset from zero on the receiver. Finally, the circuits were reconnected as in figure 2 to make sure that no significant drift occurred during the calibration.

The above procedure determined the output power from the probe at B with respect to 1 mW. In other words, if the final RVA setting was K dB and the receiver offset was L dB, then the probe output signal would be (K+L) dB below 1 mW. Eq (1) can then be used to calculate the incident on-axis power density, and the power densities at all other points are known since they were measured with respect to the on-axis value.

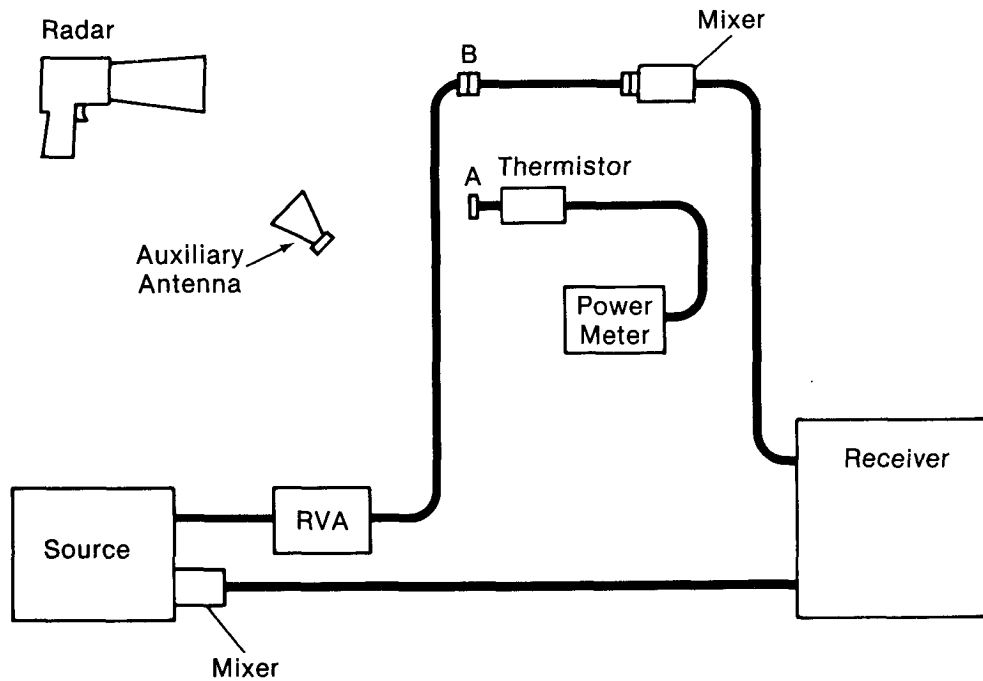

Figure 3. Schematic diagram of measurement system as it is connected for calibrating the probe output signal. The 1 mW calibrating signal is inserted at B and compared with the signal produced by the probe antenna (see sec. 2.3.1 for details).

This calibration procedure was repeated at every measurement distance used for each radar.

### 2.3.2 Estimated Measurement Accuracy

According to eq (1), the accuracy of the measured power density depends on how accurately the received power is determined by the calibration procedure of the preceding section, and on how well  $G_p$ , the gain of the probe, is known. The accuracy of the  $P_R$  calibration depends, in turn, on the accuracies of the attenuator, thermistor, power meter, and receiver. An additional factor is the degree of repeatability associated with the disconnection and connection of the transmission lines and probe at points A and B of figures 2 and 3. Any amplitude drifts in system components or in the radar itself will also affect the repeatability.

The RVA is a calibrated, precision laboratory standard with an uncertainty of less than  $+0.02$  dB over the range 0 to 20 dB used for these measurements. The thermistor mounts were calibrated to account for mismatch effects, loss due to absorption within the mount but not in the thermistor elements, and the dc-to-microwave substitution error. The estimated uncertainty associated with the thermistor mount is  $+0.06$  dB, and the uncertainty of the power meter used with the thermistor mount is  $+0.13$  dB. The uncertainty due to non-linearity of the receiver is  $+0.04$  dB.

The repeatability error was determined by repeating the procedure of section 2.3.1 and observing any variations in the attenuator setting and receiver readings. The final receiver reading, following reconnection of the probe, was especially significant for indicating drift and flange

connection errors. The uncertainty due to non-repeatability was estimated to be  $\pm 0.20$  dB.

The theoretical gain value of each probe at the frequency of interest was used. These values are:

X-Band (10.53 GHz)	16.7 dB $\pm$ 0.3 dB
K-Band (24.15 GHz)	6.7 dB $\pm$ 0.3 dB

These gains could have been determined to within  $\pm 0.1$  dB by careful calibration, but it was not considered worth the added effort and expense in view of the other errors associated with the measurement. In addition, there is undoubtedly some variation in the output of different radar units of the same model, so there is not much to be gained by testing a particular radar to such accuracy. A near-zone gain correction for the X-Band probe was required at the closest separation distance and has been included in the calculations.

The errors associated with these measurements are summarized below:

<u>Source of error</u>	<u>Uncertainty (in decibels)</u>
Rotary-vane attenuator	$\pm 0.02$ dB
Thermistor mount	$\pm 0.06$ dB
Power meter	$\pm 0.13$ dB
Receiver non-linearity	$\pm 0.04$ dB
Connector repeatability and system drift	$\pm 0.30$ dB
Uncorrected mismatch error	$\pm 0.10$ dB
Probe antenna gain	$\pm 0.30$ dB
Total error sum:	$\pm 0.95$ dB

The listed errors are approximate worst-case values and, since the errors are uncorrelated, the sum represents a conservative estimate for the total error.

Although an estimated error approaching  $\pm 1$  dB may seem rather high, it should be noted that radiated power density is a particularly difficult parameter to measure with high accuracy because of the many variables and precise calibrations involved. In this case, the two largest sources of error were associated with the gain of the probe antenna and with connector repeatability and system drift. As has already been mentioned, the gain uncertainty could be reduced to  $\pm 0.10$  dB by careful calibration, and the repeatability could probably be improved to  $0.10$  to  $0.15$  dB through the use of precision connectors. These improvements would result in an overall error of approximately  $\pm 0.5$  dB, which is about the best one could expect. However, considering the variability that exists among radar units of the same type and the variable effects of the immediate operational radar environment on the radiated field strength, the approximate  $\pm 0.3$  dB improvement in accuracy did not justify the use of the more expensive and time-consuming techniques required to achieve it.

## 2.4 Measurement Procedures and Results

### 2.4.1 Alignment and Measurements

The mounting arrangement is shown in figure 4. A ring mount was constructed which clamped to the radar being measured. The ring mount was attached to a tilt plate which was, in turn, attached to a translation plate. The translation plate was bolted to the model mount. A handgun is shown mounted in figure 4, but the same basic arrangement was used for all the radars tested. Care was taken to assure that the radar aperture was always well in front of the metal mounting ring to minimize perturbation of the pattern by the mount.

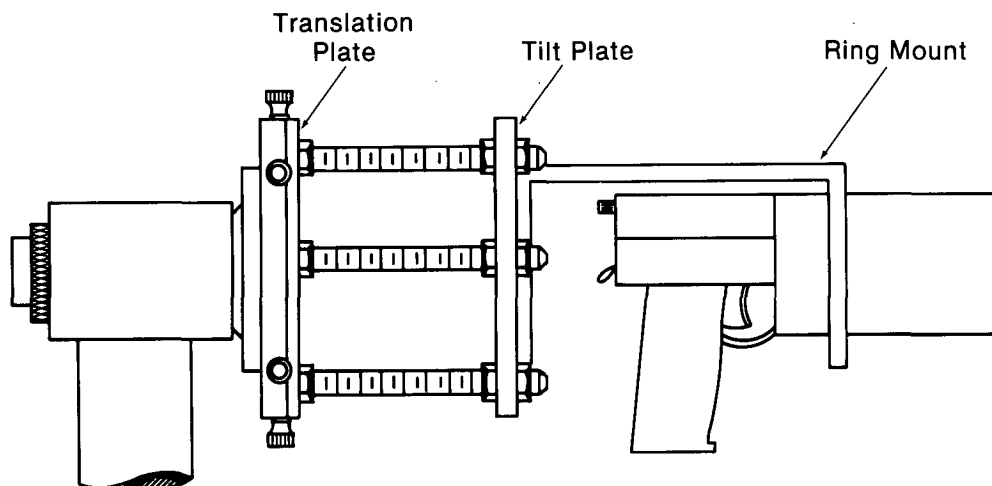

Figure 4. Mounting arrangement used to support radars so that they could be properly aligned for radiated power density measurements.

Although mechanical, optical, and electrical techniques for antenna alignment were employed, the final test involved only electrical measurements of the fields emitted by the test antenna. Proven methods were used for the precise alignment of each radar. The objective was to assure that the radar axis coincided with the  $\phi$  rotation axis of the model mount and that for  $\theta=0$ , the axes of the probe, radar, and model mount were all coincident with the z-axis of the coordinate system of figure 1. Once this was accomplished, the z-position of the radar was adjusted slightly by moving the model mount with respect to the azimuth rotator until rotation in  $\theta$  produced minimal phase variations. This adjustment was done to place the rotation axis at the phase center of the radar.

After the alignment was completed, a set of data was obtained by rotating the radar  $360^\circ$  about the  $\theta$  axis, recording the field strength at  $5^\circ$  intervals in  $\theta$ , and repeating the process for  $10^\circ$  increments in  $\phi$  until the entire sphere was scanned. This procedure yielded data along the  $10^\circ$  meridians of a sphere.



The total power density is the sum of the power densities associated with two orthogonal field components. Therefore, at each measurement distance, two complete scans must be performed, one for each component. Since the probes were linearly polarized, they were oriented to respond to the vertical component for one scan and then rotated  $90^\circ$  to respond to the horizontal component for the second scan. The entire process was carried out at four distances for each radar, the distances being 1, 3, 6, and 12 ft (30, 91, 183, and 366 cm) for the X-Band radars and 1, 3, 6, and 10 ft (30, 91, 183, and 305 cm) for the K-Band radars. The largest K-Band distance was restricted to 10 ft (305 cm) because the probe assembly was longer than the X-Band probe and the overall distance available was limited by the length of the rails on which the rotator was mounted. At the shortest distance, 12 in (30 cm), the rotation about the  $\theta$  axis was limited to the range  $-135^\circ$  to  $+135^\circ$  in order to avoid hitting the probe antenna with the rear of the model tower.

#### 2.4.2. Results

The power density values were obtained as follows. Results of the calibration procedures described in section 2.3.1 were analyzed and used to calculate the received power at the on-axis reference point, which we shall call  $P_R'$ . The values of  $P_R'$  obtained during the scanning process were measured relative to this on-axis value. Once  $P_R'$  had been calculated, the received power in mW at each measurement point was determined and the corresponding incident power density was then calculated by eq (1), for each point. The power densities for each component were summed to give the total power density at each point. These calculations were performed using the NBS computing facilities, and one of a variety of plotting routines was selected to display the results in graphical form.

In order to determine the symmetry of typical radiation patterns, contour plots like that in figure 10 (see sec. 5) were generated for selected radars. Note that the beam possesses circular symmetry down to about 23.4 dB below the peak (42 dB below  $1 \text{ mW/cm}^2$ ). This symmetry is typical of all the radars tested. Because of the uniformity between radar units, it was decided not to provide contour plots for each distance for 20 radars.

A graphical display which presents the power density information in a more useful form is the polar coordinate format used in figures 11 through 50. These graphs display the power density in  $\text{mW/cm}^2$  or dB with respect to  $1 \text{ mW/cm}^2$  as functions of the angle off axis and the distance from the radar. Each figure has four curves, one for each measurement distance, and figures were prepared for both the vertical (elevation) and horizontal (azimuth) pattern cuts in order to display the effects of any significant asymmetries which might exist. The vertical and horizontal planes are defined with respect to the radars when mounted in their normal upright configurations and pointed horizontally as in figure 1. The horizontal and vertical cuts correspond to  $\phi=0$  and  $90^\circ$ , respectively. In each figure the origin corresponds to a power density of  $10^{-5} \text{ mW/cm}^2$ . The power density in dB corresponding to a particular distance and elevation or azimuth angle (equal to  $\theta$  for these principal plane cuts) is proportional to the length of the radius vector from the origin to the point selected on the particular distance curve. Therefore, the inner curve represents the smallest power density and is for the largest distance from the radar. The strongest fields are associated with the closest distance 12 in (30 cm) and are plotted on the outer curve. This format provides a good visual representation of the field patterns as viewed by an operator positioned behind the radar and looking in the direction the radar is aimed.

The nomenclature used to identify the radars (X-1, K-1, etc.) is identical to that used in task 2 so that results between tasks may be compared if desired. Fourteen X-Band and six K-Band radar units were tested during task 1 and 15 X-Band and seven K-Band radar units were tested during task 2.

### 3. TASK 2 MEASUREMENTS

#### 3.1 General Approach

Since speed radar units are usually mounted on or inside an automobile, a complete investigation of microwave radiation levels requires that measurements be made inside the automobile under normal operating conditions. By this means it is possible to observe any field enhancement effects produced by the automobile enclosure. Each of the 22 radar units tested was mounted in the positions in which it is normally used, and calibrated field probes were used to measure the power density ( $\mu\text{W}/\text{cm}^2$ ) throughout the interior of the car, paying particular attention to regions where the head and groin would be located.

#### 3.2 Probes Used for the Vehicular Measurements

Two different probes were used for these measurements. An NBS Model EDM-1C Electric Energy Density Meter was used for the measurements involving the X-Band (10.525 GHz) radars. This NBS probe does not operate above X-Band, so a commercial Electromagnetic Radiation Monitor was used for the K-Band (24.15 GHz) measurements. The sensor antennas in both probes consisted of three orthogonal dipoles in order to achieve isotropic response patterns. The measurements are, therefore, quite insensitive to the orientation of the probe with respect to the field being measured, as long as the probe handle is not pointed toward the radiation source. The NBS probe uses diodes for the detecting elements, while the commercial unit employs thermocouples. Consequently, the NBS probe has greater sensitivity; its threshold response being  $0.001 \mu\text{W}/\text{cm}^2$ . With the commercial meter, the minimum detectable power density was  $0.01 \mu\text{W}/\text{cm}^2$ . Both probes make use of high-resistance leads between the sensor and metering unit to eliminate pickup by the leads which would generate an error signal.

The meters were calibrated by the free-space standard-field method which is illustrated in figure 5. The power density,  $W$ , at a point on the transmitting axis at a distance  $d$  from the standard gain horn is given by

$$W = \frac{P_T G}{4\pi d^2}$$

where  $P_T$  is the net power delivered to the horn and  $G$  is the effective gain of the horn. The gain was determined in advance [2] and  $P_T$  and  $d$  were measured as part of the calibration procedure. The incident power  $P_i$  and reflected power  $P_r$  were monitored with the coupler sidearms, and  $P_T = P_i - P_r$ . When  $W$  had been determined at a particular point, the probe being calibrated was placed at this same point in the known field and a probe correction factor was obtained from the ratio of the actual power density to the indicated power density.

The error in the basic calibration was estimated to be  $\pm 0.5$  dB (12%). However, in actual use, additional uncertainties arose due to such things as multipath effects, perturbation of the field by the operator, and the fact that the probe was calibrated in a plane-wave field but was used in a more complex field configuration. Taking all of these factors into consideration resulted in an estimated overall measurement uncertainty of  $\pm 1.0$  dB (25%). Although it may seem rather high, a  $\pm 1.0$  dB uncertainty is very good for electromagnetic field measurements performed in such a complicated electromagnetic environment.

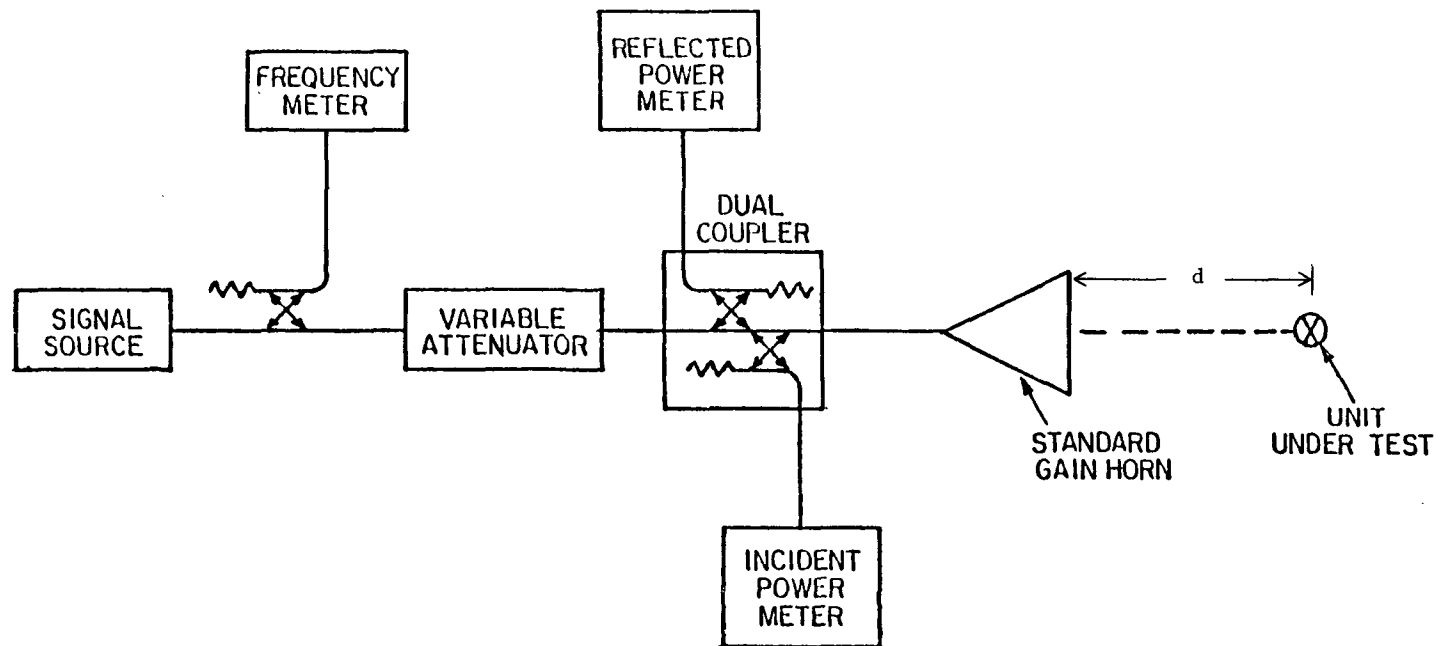

Figure 5. Diagram of the basic experimental arrangement required for the free-space standard-field method of calibrating microwave hazard meters.

### 3.3 Measurement Procedures and Results

Prior to making measurements inside the automobile, the power density in the main beam, close to the aperture, was determined by holding the probe directly in front of the aperture as shown in figure 6. These results are listed in column 2 of table 1. The maximum power density radiated to the sides and rear of each unit was also determined by moving the probe over the surface of the unit as shown in figure 7 and observing the maximum indication. These values are listed in column 3 of table 1.

Following the above tests, the radars were mounted in, on, or hand-held in a four-door sedan in the various operating positions indicated by the numbers in figure 8. In positions 1 and 2, the radars were hand-held and aimed through the windshield. Position 5 is the common dashboard mount with the radar aimed forward (fig. 9a), and 5R is the same arrangement with the radar aimed to the rear through the back window (fig. 9b). In positions 6 and 7 the radars were hand-held and aimed out the left and right front side windows, respectively. For position 3, the radar was attached to the inside of the right rear window and aimed forward through the windshield while, in position 4, the radar was attached outside the left rear window and aimed forward. In position 8, the radar was aimed to the rear through the back window.

Each radar unit was mounted in each of the positions in which it was designed to operate, as indicated in column 4 of table 1. With the radar in each position, the appropriate hazard probe was used to survey the field intensity throughout the interior of the automobile. The maximum power densities observed in the general regions occupied by the driver and three passengers (locations A through D of fig. 9) are given in table 1, columns 5-8. These recorded values represent the maximum levels observed, that is, there were no values of higher radiation intensity in locations other than those whose power density values are listed in table 1.

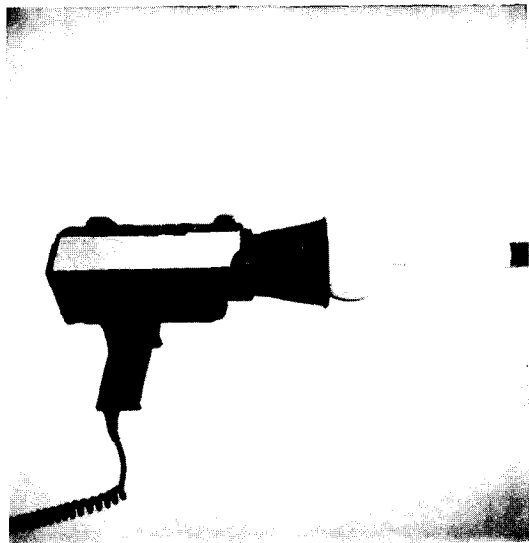

Figure 6. Measurement of main-beam power density in the aperture region.

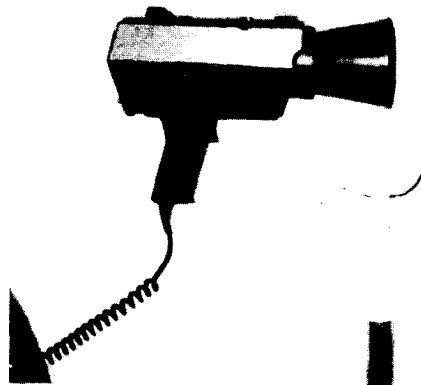
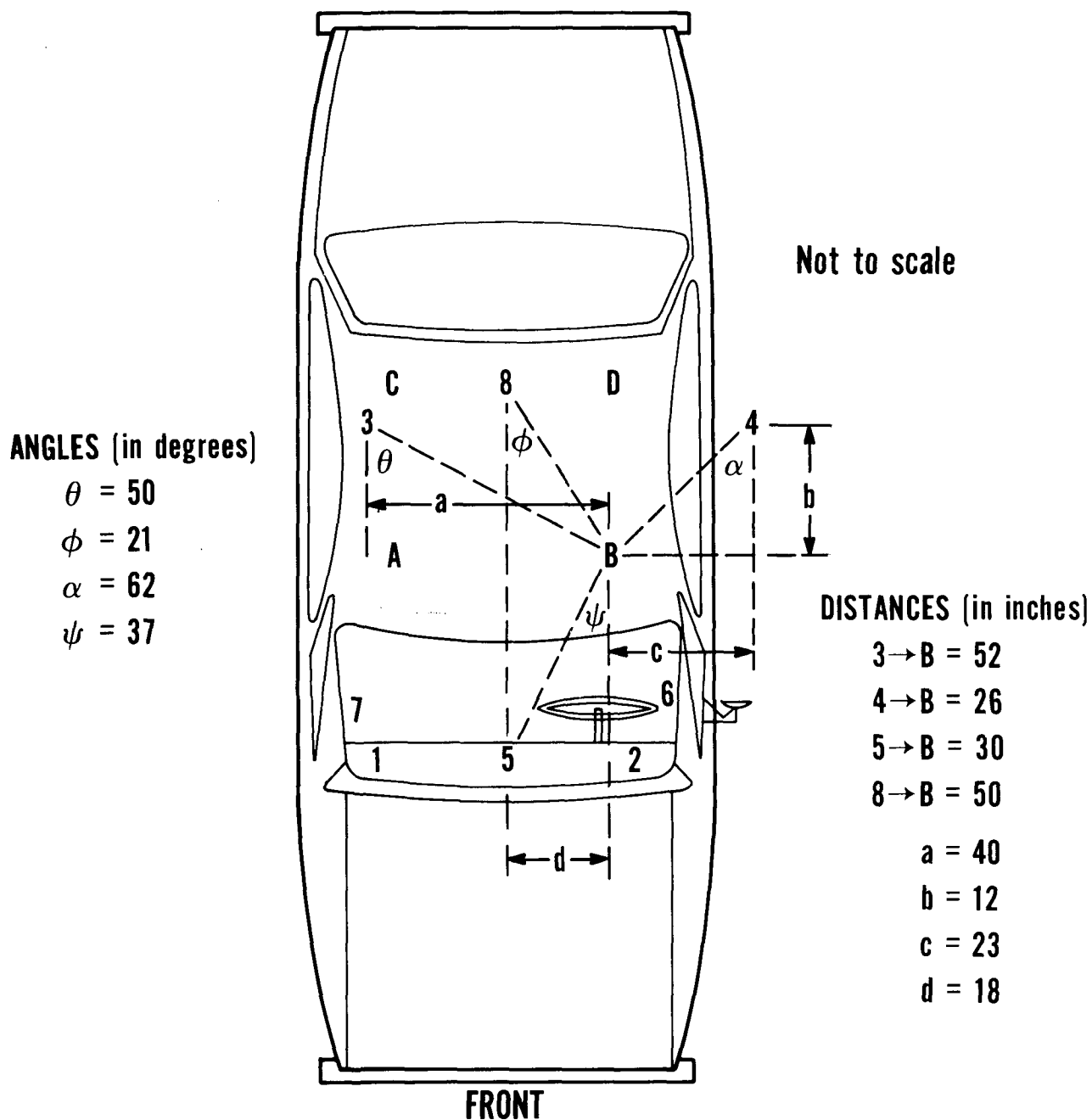

Figure 7. Measurement of radiation in the side- and back-lobe regions.



Numbers are radar mounting positions.  
 Letters are seat positions.

Figure 8. Diagram showing the location of radar mounting positions (1-8), seat locations (A-D), and distances between selected radar positions and seat locations used in describing field intensity distributions inside the automobile.

Table 1. Results of vehicular power density measurements.

This table contains results of measurements of field intensities produced by the various radar units inside an automobile. The radar code numbers are given in the first column, with the K-Band units (24.15 GHz) designated by K-1 to K-7 and the X-Band units (10.525 GHz) by X-1 to X-15. Column 2 gives the power density in the aperture, and column 3 the maximum power density in the back hemisphere. The mounting positions of column 4 correspond to the numbered positions of figure 8 as described in the text. The interior vehicular data are given in columns 5 to 8. Blank entries in these columns mean that the field intensities were too low to read with the meters used for these tests; i.e., the fields were  $<0.01 \text{ mW/cm}^2$  for K-Band and  $<0.001 \text{ mW/cm}^2$  for X-Band.

Radar code number	Aperture power density ( $\text{mW/cm}^2$ )	Maximum back-lobe power density ( $\text{mW/cm}^2$ )	Radar mounting position	Maximum power density at positions A, B, C, and D of figure 8 ( $\text{mW/cm}^2$ )			
				A	B	C	D
K-1	1.97	<0.01	5 8				
K-2	2.40	0.02	1 2 5 5R <sup>a</sup> 8	0.01	0.01		
K-3	2.27	<0.01	1 2 5				
K-4	1.83	<0.01	1 2 5				
K-5	0.25	<0.01	1 2 5 5R <sup>a</sup>				
K-6	2.78	0.02	1 2 5				
K-7	1.64	<0.01	1 2 5				
X-1	0.55	<0.001	1 2 3 4	0.001 0.137	0.001 0.001	0.002	0.002
X-2	0.73	0.001	1 2 3 4	0.001 0.36	0.001 0.003 0.002	0.001	0.001
X-3	2.82	0.018	1 2 5	0.002 0.001 0.002	0.003 0.021 0.001	0.001	0.001
X-4	2.55	0.018	1 2 5	0.002 0.001 0.001	0.001 0.003 0.001	0.001	0.001
X-5	0.36	0.001	1 2 5				

Table 1. Results of vehicular power density measurements (Continued)

Radar code number	Aperture power density (mW/cm <sup>2</sup> )	Maximum back-lobe power density (mW/cm <sup>2</sup> )	Radar mounting position	Maximum power density at positions A, B, C, and D of figure 8 (mW/cm <sup>2</sup> )			
				A	B	C	D
X-6	1.19	0.002	1				
			2				
			5				
			6				
			7		0.001		
X-7	1.10	0.004	1	0.001			
			7	0.002	0.001		
			2				
			6	0.001	0.002		
			5		0.001	0.001	
X-8	0.89	0.002	1				
			7				
			2				
			6				
			5				
X-9	0.96	0.004	1	0.001			
			7				
			2				
			6				
			5 5R <sup>a</sup>				
X-10	1.76	0.008	1	0.001			
			7				
			2				
			6				
			5	0.001			
X-11	0.46	0.001	1				
			7	0.001			
			2		0.001		
			6				
			5				
X-12	0.59	0.005	5				
X-13	0.93	0.003	1				
			2				
			5				
			6				
			7				
X-14	0.48	0.001	1				
			2				
			5				
			6				
			7				
X-15	2.29	0.018	1				
			2				
			5				
			6		0.002		
			7	0.002			

<sup>a</sup>Same location as radar mounting position 5 except that the radar is pointed toward the rear of the vehicle.

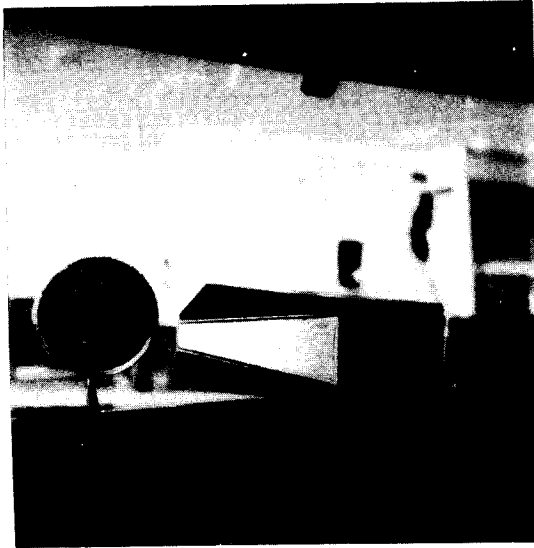

a)

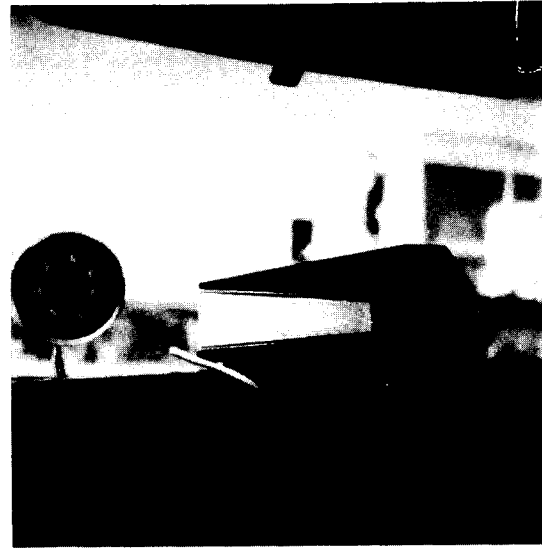

b)

Figure 9. Typical dashboard mounting arrangement:  
 a) shows the radar pointing forward, and b)  
 shows the radar aimed to the rear through the  
 back window.

#### 4. DISCUSSION OF MEASUREMENT RESULTS FOR TASKS 1 AND 2

It is not the purpose of this report to state what levels of electromagnetic fields constitute a health hazard. Such issues are left to those organizations and committees that have been established to perform and interpret research on the biological effects of electromagnetic waves and to set exposure limits based on the results of such research.

From the graphs of figures 11 through 50 one can obtain the expected power density in any desired region of space. For example, from the horizontal cut for X-1 (fig. 11), it is evident that, for distances greater than 12 in (30 cm) and for all angles, the power density is less than  $0.2 \text{ mW/cm}^2$  (-7 dB). Another way of using the curves is to determine regions where a specified power density such as  $0.1 \text{ mW/cm}^2$  is not exceeded. From figure 11, it is clear that the power density is less than  $0.1 \text{ mW/cm}^2$  (-10 dB) at all angles for distances greater than about 36 in (91 cm) and also for distances greater than 12 in (30 cm) if the angle is greater than approximately  $\pm 10^\circ$  off axis. Similar determinations can be done for the other radars using the appropriate graphs.

Section 1910.97 of the Occupational Safety and Health Act (OSHA) contains a Radiation Protection Guide (RPG) which applies to exposure to electromagnetic radiation at various frequencies. At frequencies of 10 MHz to 100 GHz, the RPG allows exposure up to a power density of  $10 \text{ mW/cm}^2$  over any 0.1-h period, or up to a power density of  $10 \text{ mW/cm}^2$  averaged over any 0.1-h period or more. Concurrently, a voluntary Radio Frequency Protection Guide of  $5 \text{ mW/cm}^2$  for the 1500 MHz to 100 GHz frequency range is under consideration for adoption by the American National Standards Institute. Whether the power density exposure limit remains at  $10 \text{ mW/cm}^2$  or is lowered to  $5 \text{ mW/cm}^2$ , the power densities measured at a 12 in (30 cm) distance from the radars did not exceed either limit, even if operated continuously. The



K-Band radars tended toward higher powers and, since the antennas had more gain than the X-Band antennas, it was not surprising to observe that the power densities were generally higher for most K-Band units. In fact, all except K-5 had on-axis power densities of approximately  $1 \text{ mW/cm}^2$  at the 12 in (30 cm) distance. For comparison, the U.S.S.R. defines safe exposure limits at  $10 \text{ } \mu\text{W/cm}^2$  for a whole working day or exposure for not more than 15 or 20 min a day at  $1 \text{ mW/cm}^2$  while wearing goggles [3].

The aperture power density for most of the units, measured in task 2 (col. 2 of table 1) is a significant fraction (25 to 50%) of the existing or proposed maximum permissible exposure levels. Based on the back-lobe data (col. 3 of table 1), one can conclude that all units are well-designed and packaged to provide shielding from leakage and back radiation. There was not a single case of reverse-hemisphere radiation of sufficient intensity to cause concern. In most cases, the power densities were  $\frac{1}{1000}$ , or less, of the exposure limit presently specified in the OSHA guide.

The data in columns 5 to 8 of table 1 indicate that the field levels inside the car do not exceed  $0.002 \text{ mW/cm}^2$  for most radar positions. The major exception occurs in the data for X-1 and X-2 which show relatively strong fields at location A when the radar is mounted in position 3. This is to be expected since location A, the front seat passenger position, is directly in the main beam for this situation. Note, however, that the field strength recorded at the driver location is still low.

## Appendix B -References

- [1] Silver, S. Microwave antenna theory and design. New York, NY: McGraw-Hill; 1949. 1-4.
- [2] Newell, A. C.; Baird, R. C.; Wacker, P. F. Accurate measurement of antenna gain and polarization at reduced distances by an extrapolation technique. IEEE transactions on antennas and propagation. AP-21(4): 419-431; 1973 July.
- [3] Baranski, S.; Czerski, P. Biological effects of microwaves. Stroudsburg, PA: Dowden, Hutchinson and Ross, Inc.; 1976. 177.

U.S. GOVERNMENT PRINTING OFFICE: 1983-0-381-428/2424