



EVALUATION OF FRA TRESPASS PREVENTION RESEARCH STUDY

SUMMARY

The United States Department of Transportation’s (US DOT) John A. Volpe National Transportation Systems Center (Volpe Center), under the direction of the US DOT Federal Railroad Administration (FRA) Office of Research and Development (R&D), conducted an independent internal evaluation of the FRA-sponsored Trespass Prevention Research Study (TPRS).

The Volpe Center conducted the TPRS from 2009-2013 to develop and demonstrate trespass prevention and mitigation best practices. The study focused on a 7-mile stretch of South Florida Regional Transportation Authority (SFRTA) Right-of-Way (ROW) on which SFRTA, CSX, and Amtrak trains operate, and 5 miles of Florida East Coast Railway Company (FEC) ROW in the City of West Palm Beach, Florida.

This evaluation focused on the design and implementation of the TPRS rather than the impact or efficacy of specific trespass prevention treatments. The evaluation identified lessons learned to use in the design and implementation of future trespass prevention studies, for example:

- Clarify upfront study’s intended outcome;
- Anticipate likely resource needs to support counter-measure implementation;
- Have a replicable research design;
- Engage stakeholders around specific issues; and
- Use risk-based metrics to assess impact.

BACKGROUND

The leading cause of rail-related deaths in America is trespassing on railroad rights-of-way. Nationally, more than 430 trespass fatalities and nearly as many injuries occur each year, and the vast majority of these are preventable.

In designing TPRS, the researchers used a guidebook developed jointly by FRA and Transport Canada, specifically “A Community, Analysis, Response and Evaluation (CARE)” model shown in Figure 1. The CARE guide describes an approach to trespass prevention that engages community representatives in a collaborative problem-solving effort to reduce trespass incidents. The procedures and benefits of this guide had not been evaluated in the United States.

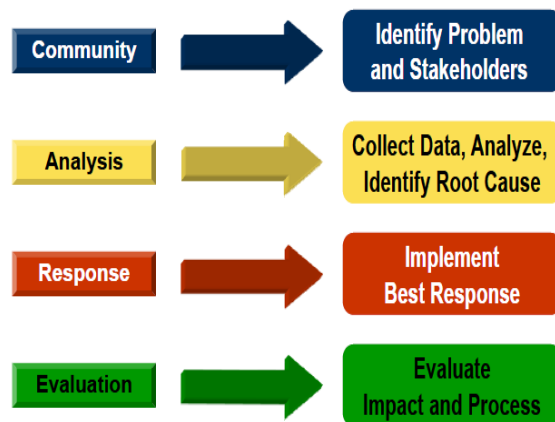

Figure 1: CARE Model



OBJECTIVES

The evaluation of TPRS was intended to identify and document lessons learned from the design and the conduct of the study. These lessons would inform the design of future trespass prevention research efforts. Because most of the potential countermeasures that were recommended by the study have not been carried out yet, the evaluators focused on the project's implementation (or process) instead of studying the impact of countermeasures.

The evaluation asked the following questions:

- **Project Design** - What characteristics of the Field Operational Test's (FOT) design allowed its activities to be completed as planned? How could the FOT design be improved?
- **Project Operation** - How did the approach to implementing the FOT affect the extent to which its goals were achieved?
- **Project Setting** – What characteristics of the community and site influenced the FOT's implementation?

METHODS

To answer the questions posed by the study, the following tasks were undertaken:

- Assemble and review relevant project source materials;
- Interview key FRA staff, Volpe staff and primary participants in Florida – once to scope the evaluation, and a second time to pursue specific evaluation questions;
- Research cases of similar FOTs elsewhere; and
- Comparing and contrasting viewpoints expressed among all data sources

A logic model was developed to make the design of the TPRS explicit and to guide the

evaluation.

FINDINGS

The evaluation identified a number of benefits and lessons learned from the implementation of the TPRS.

Benefits

The benefits included the following:

- The study fostered relationships among core rail safety stakeholders (SFRTA, FDOT, City of West Palm Beach);
- Stakeholders praised technical rigor and use of train-mounted video recordings to support hazard analysis;
- The study mobilized core stakeholders to support limited implementation of trespass prevention countermeasures; and
- Many lessons learned can be used in future research and national guidance on trespass prevention.

Project Design

Lessons learned about project design included:

- The CARE guide as written is too general to provide guidance on technical issues such as risk assessment and specific trespass prevention treatments;
- The study's design would have benefited from the incorporation of findings from evaluation research of analogous community-based interventions in the field of public health and safety; and
- To address trespass issues holistically, a broad range of expertise is needed (including human factors and community engagement expertise).

Project Operation

The evaluation identified two key lessons learned regarding project operation of the TPRS:

- Train-mounted video data can be used to (1) inform hazard analysis by identifying the highest trespasser exposure areas and (2) engage with local stakeholders to motivate



- community-based actions (see Figure 2).
- Outcome/success metrics for trespass prevention interventions must be carefully selected. Trespass incidents can provide an accurate leading indicator of risk exposure along railroad ROW, while trespass fatalities and injuries are generally too infrequent to provide a reliable indicator of risk for evaluating the impact of trespass countermeasures in specific corridor segments.

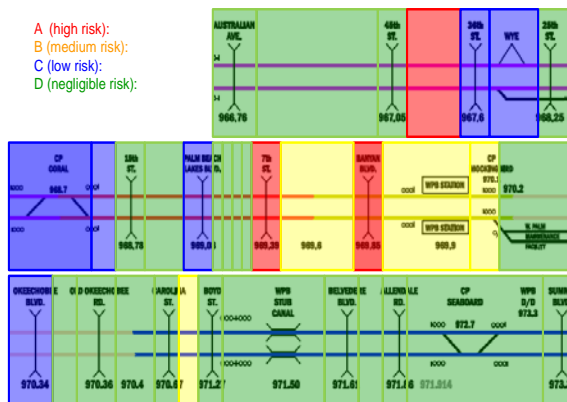

Figure 2: SFRTA Corridor Map Risk Areas

Project Setting

Lessons learned from the social, institutional and geographic setting in which the TPRS took place included:

- It is essential to clarify the project's goals both upfront and periodically, as well as the roles and responsibilities of different participants (federal, state, and local);
- Corrective actions need to be anticipated, particularly in terms of funding requirements; and
- The study's design and conduct needs to tie stakeholder engagement to specific trespassing sites and shared concerns.

CONCLUSIONS

This evaluation analyzed the implementation of a previously untested trespass prevention model. Since the CARE model was implemented in a single community, it was difficult to draw broad conclusions about its effectiveness. The model's successes and implementation challenges in West Palm Beach were the result of multiple interrelated factors, many of which are dynamic and difficult to discern individually.

The TPRS revealed some of the potential strengths and weaknesses of the CARE model. A key finding from the study is that community-based intervention strategies such as the CARE model may help railroad agencies or other concerned stakeholders better leverage community resources and apply diverse safety strategies. Such collaborative efforts may yield long-term safety benefits by raising awareness and building relationships among critical stakeholders. However, it is not clear if multiple stakeholders can maintain a high level of engagement for significant periods of time without the commitment of substantial resources or the presence of at least one strong and dynamic local champion. A key weakness of the CARE model is that it is resource-intensive and time-intensive, which requires committed stakeholders with the power and incentives to implement proposed responses. Furthermore, when the CARE model was implemented, lessons learned from analogous community-based interventions in other fields were not incorporated.

Given the potential weaknesses of the CARE model, it is important that FRA refines the model to align more with community-based interventions that have proved effective in the past.



Incorporating several key elements into the design of future trespass prevention research may improve the likelihood of success. Those elements include:

- Define project goals and success measures explicitly;
- Establish clear safety risk metrics and measure baseline and post-intervention risk condition;
- Screen and select sites based on rigorous criteria and pre-selection investigations;
- Clarify roles for community stakeholders and funding sources for project implementation at the onset of the project;
- Pursue targeted stakeholder engagement strategies that are tailored to specific stakeholder groups;
- Build in post-project monitoring of stakeholder engagement and project outcomes to identify long-term critical success factors; and
- Integrate lessons learned from the implementation of community-based approaches to public health and safety.

The TPRS study successfully identified how to refine the CARE model and improve its potential effectiveness in communities where rail trespassing is a problem. Lessons from the TPRS study can help identify the appropriate circumstances where community-based interventions are warranted and likely to be effective. More broadly, this evaluation demonstrates how the application of formal evaluation practices to FRA research can inform improvement-oriented processes as well as future research priorities.

REFERENCES

[1] USDOT/FRA/Office of Railroad Safety, [Community Trespassing Prevention Guide](#), 2003, updated December, 2011.

AUTHORS

Aaron Jette and David Damm-Luhr
Volpe National Transportation Systems Center
Organizational Performance Division
55 Broadway, Cambridge, MA 02142

Joyce Ranney
Volpe National Transportation Systems Center
Surface Transportation Human Factors Division
55 Broadway, Cambridge, MA 02142

ACKNOWLEDGMENTS

This work was performed under an intra-agency agreement between FRA's Office of Research and Development and the Volpe National Transportation Systems Center's Surface Transportation Human Factors Division

CONTACT

John Tunna, Director
Federal Railroad Administration
Office of Research and Development
1200 New Jersey Avenue, SE
Washington, DC 20590
(202) 493-6359; john.tunna@dot.gov

Michael Coplen
Federal Railroad Administration
Office of Research and Development
Human Factors Division
1200 New Jersey Avenue, SE
Washington, DC 20590
(202) 493-6346; michael.coplen@dot.gov

KEYWORDS

Trespass Prevention, Evaluation, Community-Based, Stakeholder Engagement

Notice and Disclaimer: This document is disseminated under the sponsorship of the United States Department of Transportation in the interest of information exchange. Any opinions, findings and conclusions, or recommendations expressed in this material do not necessarily reflect the views or policies of the United States Government, nor does mention of trade names, commercial products, or organizations imply endorsement by the United States Government. The United States Government assumes no liability for the content or use of the material contained in this document.