

Ref.
CG-94-5
v.2

USCG-M-1-94.2
DOT-VNTSC-CG-94-5.2

Passenger Vessel Damage Stability Study for 1990 SOLAS Amendments Volume II Appendix B

Michael G. Dyer

Research and
Special Programs
Administration
Volpe National
Transportation Systems Center
Cambridge, MA 02142-1093

Final Report
September 1994

This document is available to the public
through the National Technical Information
Service, Springfield, VA 22161

U.S. Department
of Transportation
United States
Coast Guard



Office of Marine Safety, Security,
and Environmental Protection
Washington, DC 20593

NOTICE

This document is disseminated under the sponsorship of the Department of Transportation in the interest of information exchange. The United States Government assumes no liability for its contents or use thereof.

REPORT DOCUMENTATION PAGE

Form Approved
OMB No. 0704-0188

Public reporting burden for this collection of information is estimated to average 1 hour per response, including the time for reviewing instructions, searching existing data sources, gathering and maintaining the data needed, and completing and reviewing the collection of information. Send comments regarding this burden estimate or any other aspect of this collection of information, including suggestions for reducing this burden, to Washington Headquarters Services, Directorate for Information Operations and Reports, 1215 Jefferson Davis Highway, Suite 1204, Arlington, VA 22202-4302, and to the Office of Management and Budget, Paperwork Reduction Project (0704-0188), Washington, DC 20503.

1. AGENCY USE ONLY (Leave blank)		2. REPORT DATE September 1994		3. REPORT TYPE AND DATES COVERED Final Report 1994	
4. TITLE AND SUBTITLE Passenger Vessel Damage Stability Study for 1990 SOLAS Amendments - Volume II, Appendix B				5. FUNDING NUMBERS B4039 CG486	
6. AUTHOR(S) Michael G. Dyer					
7. PERFORMING ORGANIZATION NAME(S) AND ADDRESS(ES) Department of Transportation John A. Volpe National Transportation Systems Center 55 Broadway Cambridge, MA 02142				8. PERFORMING ORGANIZATION REPORT NUMBER DOT-VNTSC-CG-94-5.2	
9. SPONSORING/MONITORING AGENCY NAME(S) AND ADDRESS(ES) U.S. Coast Guard Headquarters Commandant G-MTH-3 2100 2nd Street, SW Washington, DC 20593				10. SPONSORING/MONITORING AGENCY REPORT NUMBER USCG-M-1-94.2	
11. SUPPLEMENTARY NOTES					
12a. DISTRIBUTION/AVAILABILITY STATEMENT This document is available to the public through the National Technical Information Service, Springfield, VA 22161				12b. DISTRIBUTION CODE	
13. ABSTRACT (Maximum 200 words) The application of new damage stability requirements in the 1990 Safety of Life at Sea (SOLAS) amendments to the United States domestic passenger fleet is investigated. The amendments specify new minimums for positive range, righting energy, and downflooding angle, maximum static heel angle, and residual righting arms in situations of applied heeling moments such as passenger crowding and wind loading. Twenty-one domestic passenger ships of recent design are analyzed for their ability to comply in damaged conditions as specified by the Coast Guard regulations. Design modifications required to bring about compliance for those vessels failing the requirements are briefly addressed. A comparison of ability to comply versus certain hydrostatic parameters is made, as well as a set of recommendations to the Coast Guard.					
14. SUBJECT TERMS Passenger vessels, damage stability, SOLAS				15. NUMBER OF PAGES 1196	
				16. PRICE CODE	
17. SECURITY CLASSIFICATION OF REPORT Unclassified	18. SECURITY CLASSIFICATION OF THIS PAGE Unclassified	19. SECURITY CLASSIFICATION OF ABSTRACT Unclassified	20. LIMITATION OF ABSTRACT		

PREFACE

This report was prepared by the John A. Volpe National Transportation Systems Center, U.S. Department of Transportation Research and Special Programs Administration for the Naval Architecture Branch (G-MTH-3) of U.S. Coast Guard Headquarters. We are thankful for the patience and advice of G-MTH-3 staff, especially Ms. Pat Carrigan, Mr. Jaideep Sirkar, and Mr. Paul Cojeen.

Accession For	
NTIS CRA&I	<input checked="" type="checkbox"/>
DTIC TAB	<input type="checkbox"/>
Unannounced	<input type="checkbox"/>
Justification	
By	
Distribution /	
Availability Codes	
Dist	Avail and / or Special
A/	

METRIC/ENGLISH CONVERSION FACTORS

ENGLISH TO METRIC

LENGTH (APPROXIMATE)

- 1 inch (in) = 2.5 centimeters (cm)
- 1 foot (ft) = 30 centimeters (cm)
- 1 yard (yd) = 0.9 meter (m)
- 1 mile (mi) = 1.6 kilometers (km)

AREA (APPROXIMATE)

- 1 square inch (sq in, in²) = 6.5 square centimeters (cm²)
- 1 square foot (sq ft, ft²) = 0.09 square meter (m²)
- 1 square yard (sq yd, yd²) = 0.8 square meter (m²)
- 1 square mile (sq mi, mi²) = 2.6 square kilometers (km²)
- 1 acre = 0.4 hectares (he) = 4,000 square meters (m²)

MASS - WEIGHT (APPROXIMATE)

- 1 ounce (oz) = 28 grams (gr)
- 1 pound (lb) = .45 kilogram (kg)
- 1 short ton = 2,000 pounds (lb) = 0.9 tonne (t)

VOLUME (APPROXIMATE)

- 1 teaspoon (tsp) = 5 milliliters (ml)
- 1 tablespoon (tbsp) = 15 milliliters (ml)
- 1 fluid ounce (fl oz) = 30 milliliters (ml)
- 1 cup (c) = 0.24 liter (l)
- 1 pint (pt) = 0.47 liter (l)
- 1 quart (qt) = 0.96 liter (l)
- 1 gallon (gal) = 3.8 liters (l)
- 1 cubic foot (cu ft, ft³) = 0.03 cubic meter (m³)
- 1 cubic yard (cu yd, yd³) = 0.76 cubic meter (m³)

TEMPERATURE (EXACT)

$$[(x-32)(5/9)]^{\circ}\text{F} = y^{\circ}\text{C}$$

METRIC TO ENGLISH

LENGTH (APPROXIMATE)

- 1 millimeter (mm) = 0.04 inch (in)
- 1 centimeter (cm) = 0.4 inch (in)
- 1 meter (m) = 3.3 feet (ft)
- 1 meter (m) = 1.1 yards (yd)
- 1 kilometer (km) = 0.6 mile (mi)

AREA (APPROXIMATE)

- 1 square centimeter (cm²) = 0.16 square inch (sq in, in²)
- 1 square meter (m²) = 1.2 square yards (sq yd, yd²)
- 1 square kilometer (km²) = 0.4 square mile (sq mi, mi²)
- 1 hectare (he) = 10,000 square meters (m²) = 2.5 acres

MASS - WEIGHT (APPROXIMATE)

- 1 gram (gr) = 0.036 ounce (oz)
- 1 kilogram (kg) = 2.2 pounds (lb)
- 1 tonne (t) = 1,000 kilograms (kg) = 1.1 short tons

VOLUME (APPROXIMATE)

- 1 milliliters (ml) = 0.03 fluid ounce (fl oz)
- 1 liter (l) = 2.1 pints (pt)
- 1 liter (l) = 1.06 quarts (qt)
- 1 liter (l) = 0.26 gallon (gal)
- 1 cubic meter (m³) = 36 cubic feet (cu ft, ft³)
- 1 cubic meter (m³) = 1.3 cubic yards (cu yd, yd³)

TEMPERATURE (EXACT)

$$[(9/5) y + 32]^{\circ}\text{C} = x^{\circ}\text{F}$$

QUICK INCH-CENTIMETER LENGTH CONVERSION

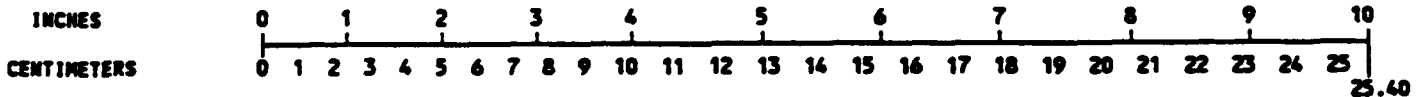

QUICK FAHRENHEIT-CELSIUS TEMPERATURE CONVERSION

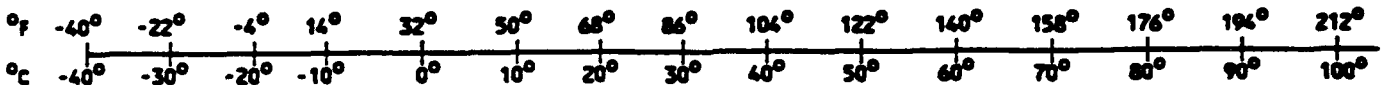

For more exact and or other conversion factors, see NBS Miscellaneous Publication 286, Units of Weights and Measures. Price \$2.50. SD Catalog No. C13 10286.

TABLE OF CONTENTS

<u>Section</u>	<u>Page</u>
Executive Summary	xi
1. Introduction	1
1.1 Purpose	1
1.2 Background	1
2. Approach	2
2.1 Assumptions and Conditions	2
3. Results	7
3.1 Fishing/Shuttle Boats	7
3.1.1 80' Fishing Boat	7
3.1.2 59' Fishing Boat	8
3.1.3 80' Shuttle Boat	10
3.2 Dinner/Excursion Boats	11
3.2.1 105' Dinner Boat	11
3.2.2 106' Dinner Boat	12
3.2.3 164' Excursion Boat	14
3.2.4 183' Dinner Boat	16
3.2.5 192' Dinner Boat	17
3.3 Casino Boats/Paddle Wheelers	18
3.3.1 80' Paddle Wheeler	18
3.3.2 198' Casino Boat	20
3.3.3 228' Casino Boat	23
3.3.4 274' Paddle Wheeler	25
3.4 Converted Crew Boats	27
3.4.1 91' Crew Boat A	27
3.4.2 91' Crew Boat B	29
3.4.3 99' Crew Boat	31
3.4.4 102' Crew Boat	32
3.4.5 122' Crew Boat	34
3.5 Passenger Cruise Vessel	35
3.5.1 180' Cruise Boat	35
3.6 Ferries	37
3.6.1 84' Ferry	37
3.6.2 175' Ferry	38
3.6.3 192' Ferry (Subchapter H)	40

<u>Section</u>	<u>Page</u>
4. Analysis	43
5 Conclusions and Recommendations	46
5.1 Summary	46
5.2 Compliance	47
5.3 Remedial Modifications for Compliance	50
5.4 General Comments on CFR §171.080	50

APPENDICES

Appendix A Wind and Passenger Heeling Moment Spreadsheets

Appendix B Hydrostatics and Damage Stability Results

Appendix C Attained Safety Factor Spreadsheets

Appendix D SOLAS 1990 Amendments and 1992 U.S. 46 CFR 171 Excerpts

NOTE: Appendix B, "Hydrostatics and Damage Stability Results", is available separately upon request, in Volume 2 of this document.

FIGURES AND TABLES

Page

Figure

3.1 198' Casino Boat as Designed	21
3.2 198' Casino Boat, Modified Arrangement	22
4.1 Attained GZ Factor vs. PAX/Displacement Ratio	45
4.2 Attained Range Factor vs. D/B and Freeboard/D	45
4.3 Attained Energy Factor vs. L/D	46

Table

E.1 Compliance Summary	xii
2.1 Vessel Particulars	3
2.2 Standard of Flooding	6
3.1 Pre-damage Conditions, 80' Fishing Boat	8
3.2 Damage Stability, 80' Fishing Boat Concept Design	8
3.3 Pre-damage Conditions, 59' Fishing Boat	9
3.4 Damage Stability, 59' Fishing Boat Departure Condition	9
3.5 Damage stability, 59' Fishing Boat Return Condition	9
3.6 Pre-damage Conditions, 80' Shuttle Boat	10
3.7 Damage Stability, 80' Shuttle Boat Departure Condition	10
3.8 Damage Stability, 80' Shuttle Boat Return Condition	11
3.9 Pre-damage Conditions, 105' Dinner Boat	11
3.10 Damage Stability, 105' Dinner Boat Departure Condition	12
3.11 Damage Stability, 105' Dinner Boat Return Condition	12
3.12 Pre-damage Conditions, 106' Dinner Boat	13
3.13 Damage Stability, 106' Dinner Boat Departure Condition	13
3.14 Damage Stability, 106' Dinner Boat Return Condition	14
3.15 Pre-damage Conditions, 200' Excursion Boat	14
3.16 Damage Stability, 200' Excursion Boat Departure Condition	15
3.17 Damage Stability, 200' Excursion Boat Return Condition	15
3.18 Pre-damage Conditions, 183' Dinner Boat	16
3.19 Damage Stability, 183' Dinner Boat Departure Condition	16

List of Tables (cont.)

<u>Table</u>	<u>Page</u>
3.20 Pre-damage Conditions, 192' Dinner Boat	17
3.21 Damage Stability, 192' Dinner Boat Departure Condition	17
3.22 Damage Stability, 192' Dinner Boat Return Condition	18
3.23 Pre-damage Conditions, 80' Paddle Wheeler	19
3.24 Damage Stability, 80' Paddle Wheeler Departure Condition	19
3.25 Damage Stability, 80' Paddle Wheeler Return Condition	20
3.26 Pre-damage Conditions, 198' Casino Boat	21
3.27 Damage Stability, 198' Casino Boat Departure Condition	22
3.28 Damage Stability, 198' Casino Boat Return Condition	23
3.29 Pre-damage Conditions, 228' Casino Boat	24
3.30 Damage Stability, 228' Casino Boat Departure Condition	24
3.31 Damage Stability, 228' Casino Boat Return Condition	25
3.32 Pre-damage Conditions, 274' Paddle Wheeler	26
3.33 Damage Stability, 274' Paddle Wheeler Departure Condition	26
3.34 Damage Stability, 274' Paddle Wheeler Return Condition	27
3.35 Pre-damage Conditions, 91' Crew Boat A	27
3.36 Damage Stability, 91' Crew Boat A Departure Condition	28
3.37 Damage Stability, 91' Crew Boat A Return Condition	28
3.38 Pre-damage Conditions, 91' Crew Boat B	29
3.39 Damage Stability, 91' Crew Boat B Departure Condition	30
3.40 Damage Stability, 91' Crew Boat B Return Condition	30
3.41 Pre-damage Conditions, 99' Crew Boat	31
3.42 Damage Stability, 99' Crew Boat Departure Condition	31
3.43 Damage Stability, 99' Crew Boat Return Condition	32
3.44 Pre-damage Conditions, 102' Crew Boat	32
3.45 Damage Stability, 102' Crew Boat Departure Condition	33
3.46 Damage Stability, 102' Crew Boat Return Condition	33
3.47 Pre-damage Conditions, 122' Crew Boat	34
3.48 Damage Stability, 122' Crew Boat Departure Condition	34
3.49 Damage Stability, 122' Crew Boat Return Condition	35

List of Tables (cont.)

<u>Table</u>	<u>Page</u>
3.50 Pre-damage Conditions, 180' Cruise Boat	35
3.51 Damage Stability, 180' Cruise Boat Departure Condition	36
3.52 Damage Stability, 180' Cruise Boat Return Condition	36
3.53 Pre-damage Conditions, 84' Ferry	37
3.54 Damage Stability, 84' Ferry Normal Operating Condition	37
3.55 Pre-damage Conditions, 175' Ferry	38
3.56 Damage Stability, 175' Ferry Departure Condition (DPA1)	39
3.57 Damage Stability, 175' Ferry Return Condition (RTA1)	40
3.58 Pre-damage Conditions, 192' Ferry	40
3.59 Damage Stability, 192' Ferry Departure Condition A	41
3.60 Damage Stability, 192' Ferry Departure Condition B	42
4.1 Attained Safety Factors	44
5.1 Heeling Arms, §171.080(e)(4)	49

ABBREVIATIONS AND SYMBOLS

AP	after perpendicular
B	maximum breadth
C_b	block coefficient
CFR	Code of Federal Regulations
FP	forward perpendicular
GG_1	shift of vertical center of gravity due to passenger movement
GZ	righting arm
GZ_{reqd}	righting arm specified by new regulation, minimum of 0.328' or GZ calculated to sustain design heeling moments
LT	long ton = 2240 lb.
MTWB	main transverse watertight bulkhead
PAX	# of passengers
SOLAS	International Convention for the Safety of Life at Sea, with amendments
VCG	vertical center of gravity
VCG_0	initial vertical center of gravity
VCG_1	vertical center of gravity compensated for shift in weight (passengers)
Δ_{intact}	intact displacement

EXECUTIVE SUMMARY

Twenty one domestic passenger ships of recent design were analyzed for their ability to comply with new damage stability requirements in the 1990 Safety of Life at Sea (SOLAS) amendments. The results include fifteen vessels studied in 1990 and six of the most recent designs, for which a 1993 study was completed. The new regulations incorporated in 46 CFR §171.080(e) greatly reduce the risks to passengers, compared to the pre-existing damage stability requirements. Design modifications required to bring about compliance for those vessels failing the requirements were briefly addressed.

The major findings were the following (detailed findings are presented in "Conclusions and Recommendations"):

- The designs studied were, for the most part, able to sustain the new requirements (see Table E.1). They greatly exceed, whether implicitly or by design, the minimal damage stability requirements of the pre-1992 CFR.
- The controlling criterion among the SOLAS amendments was, in every case, righting arm for passenger crowding heeling moment. Five vessels, four of which were 91 feet in length or less, failed this requirement. The failure of the 192' casino boat was due to inconsistent bulkhead spacing resulting in a long forward compartment.
- Only one vessel, the 80' long paddle wheeler, failed any requirements other than passenger crowding heel, those being positive range and righting energy.
- Beamy shallow forms and low displacements associated with high passenger capacities were disadvantageous relative to passenger crowding moments. Small passenger boats with low breadth to depth and high freeboard to depth ratios fared well.
- 15° downflooding protection range was not directly addressed due to software and vessel documentation limitations, but will probably impact some designs for protected waters. Various extents of access and venting modifications may be needed to satisfy this provision.
- A step-wise approach to downflooding protection reflecting service areas could preserve the intent of the new regulations while sensibly accounting for operational and design factors.
- More specificity is recommended for minimum access/egress requirements for offloading from either side of the boat and for the modeling of passenger crowding loads. It was found that the CFR, supplemented by Coast Guard letter guidance, lacks specificity and would allow wide latitude to both the designer and the inspection authority. In some cases herein, crowding scenarios resulting in compliance and failure were devised.
- The CFR does not account for grounding damage scenarios and therefore drives some designs to unduly emphasize B/5 collision damages only, e.g. extremely long centerline compartments on the 274' paddle wheeler flanked by subdivided wing spaces.

Table E.1
Compliance Summary

VESSEL (design year)	15° pos. range	2.82 ft- degree righting energy	Min. GZ passenger crowding	Min. GZ boat launch	Min. GZ wind loading	Max. angle static heel <7°
FISHING/SHUTTLE						
80' fishing boat (1993)*	yes	yes	no	NA	yes	yes
59' fishing boat (1985)	yes	yes	no	NA	yes	yes
80' shuttle boat (1993)	yes	yes	yes	NA	yes	yes
DINNER/EXCURSION BOATS						
105' dinner boat (1988)	yes	yes	yes	NA	yes	yes
106' dinner boat (1993)	yes	yes	yes	NA	yes	yes
200' excursion boat (1993)	yes	yes	yes	NA	yes	yes
183' dinner boat (1988)	yes	yes	yes	NA	yes	yes
192' excursion boat (1986)	yes	yes	yes	NA	yes	yes
CASINO BOATS/PADDLE WHEELERS						
80' paddle wheeler (1986)	no	no	no	NA	yes	yes
198' casino boat (1993)	yes	yes	no	NA	yes	yes
228' casino boat (1993)	yes	yes	yes	NA	yes	yes
274' paddle wheeler	yes	yes	yes	NA	yes	yes

Table E.1 continues on next page

**Table E.1 (cont.)
Compliance Summary**

VESSEL	15° pos. range	2.82 ft- degree righting energy	Min. GZ passenger crowding	Min. GZ boat launch	Min. GZ wind loading	Max. angle static heel ↙°
---------------	-------------------------------	--	---	------------------------------------	-------------------------------------	--

CONVERTED CREW BOATS

91' crew boat A (1986)	yes	yes	yes	NA	yes	yes
91' crew boat B (1986)	yes	yes	no	NA	yes	yes
99' crew boat (1986)	yes	yes	yes	NA	yes	yes
102' crew boat (19870)	yes	yes	yes	NA	yes	yes
122' crew boat (1987)	yes	yes	no	NA	yes	no

PASSENGER CRUISE VESSEL

180' cruise boat	yes	yes	yes	yes	yes	yes
-------------------------	-----	-----	-----	-----	-----	-----

FERRIES

84' ferry (1988)	yes	yes	yes	NA	yes	yes
175' ferry (1982) †	yes	yes	yes	NA	yes	yes
192' ferry (Sub chapter H)	yes	yes	yes	NA	yes	yes

* 80' fishing boat calculations were from "concept" drawings, using notional VCG of 9.00'.

NOTE: Results only for collision cases described in CFR are considered for this Table. Cases of groundings with extensive transverse damage conducted in the study, and not specified by CFR, are not included.

Blank page

**APPENDIX B
HYDROSTATICS AND
DAMAGE STABILITY
OUTPUT**

80' FISHING BOAT

VNTSC -- 80' FISHING BOAT
Project No. DAMSTAB (by: DYER)

HEC-HINPUT V1.22
10-26-1993

VSC -- 80' FISHING BOAT
Project No. DAMSTAB (by: DYER)

HEC-HINPUT V1.22
10-26-1993

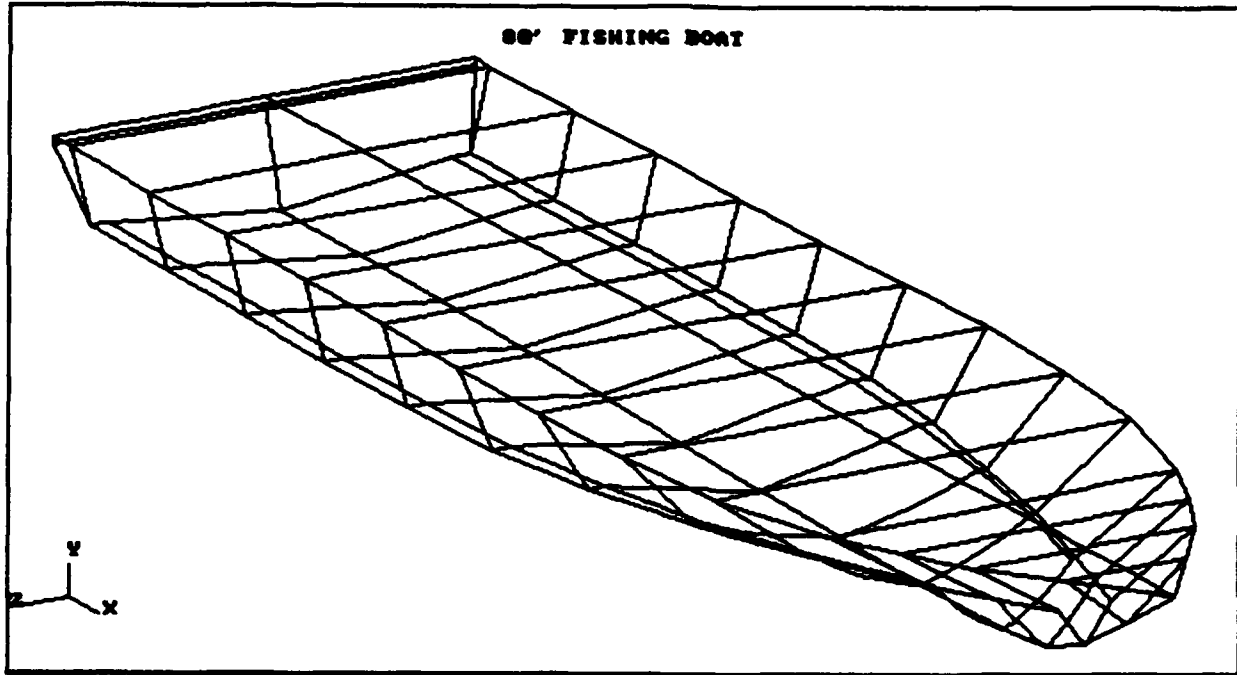

HYDROSTATIC TABLES
 80' FISHING BOAT

HOLDED DRAFT (ft)		2.500	3.000	3.500	4.000	10.500
DISP.MLD.	(LTons-SW)	48	65	83	101	323
DISP.TOTAL	(LTons-SW)	49	66	84	103	327
DISP.TOTAL	(LTons-FW)	48	64	82	100	319
LCB	(ft-FP)	46.916A	46.454A	46.042A	45.665A	40.653A
LCB (forebody)	(ft-FP)	24.315A	24.347A	24.304A	24.170A	21.167A
LCB (aftbody)	(ft-FP)	56.580A	56.406A	56.313A	56.256A	55.720A
TCB	(ft-CL)	0.000	0.000	0.000	0.000	0.000
KB	(ft)	1.636	1.930	2.215	2.493	5.418
BMT	(ft)	21.439	16.992	14.132	12.066	0.003
KMT	(ft)	23.075	18.922	16.347	14.560	5.421
BMI	(ft)	228.894	182.317	151.564	130.142	0.002
KMI	(ft)	230.530	184.248	153.778	132.635	5.421
TPI	(LTons)	2.8	2.9	3.0	3.1	0.0
	(ft-LTons)	12	13	14	15	0
	(LTons)	0.3	0.3	0.3	0.3	-0.0
LCF	(ft-FP)	45.555A	44.718A	44.122A	43.697A	4.740F
W.P. AREA	(ft ²)	1,176	1,230	1,271	1,302	17
WETTED SUR.	(ft ²)	1,287	1,392	1,487	1,574	4,284
MAX. BEAM	(ft)	21.327	21.477	21.627	21.777	24.026
LENGTH W.L.	(ft)	74.823	75.433	76.042	76.652	0.000
Cb		0.3735	0.4237	0.4632	0.4956	0.6028
Cb (forebody)		0.2238	0.2631	0.2973	0.3272	0.5257
Cb (aftbody)		0.5233	0.5844	0.6292	0.6640	0.6799
Cm		0.5586	0.6085	0.6449	0.6731	0.6924
Cp		0.6687	0.6964	0.7183	0.7362	0.8706
Cwp		0.6591	0.6893	0.7126	0.7300	0.0098
Cit		0.4171	0.4500	0.4774	0.4983	0.0003

Assumes: Sea Water at 35.0063 ft³/LT
 Fresh Water at 35.8814 ft³/LT
 Ship floating at even keel (no heel or trim)

**DAMAGE STABILITY SUMMARY
 80' FISHING BOAT**

CA. No.	FILE NAME	DAMAGED COMP. LISTING	---Intact Condition---			-----Equilibrium Condition After Damage-----					
			MIN.DRAFT (ft)	VCG (ft)	GMT (ft)	HEEL (deg)	MAX.GZ (ft)	RANGE (deg)	AREA (ft-deg)	DAM.GMT (ft)	SURVIVAL
1	NOTL001A	1	2.500	9.000	14.075	0.0	2.277	40.0	34.9	13.866	Yes
2	NOTL002A	2	2.500	9.000	14.075	0.0	2.397	40.0	37.0	14.527	Yes
3	NOTL003A	3	2.500	9.000	14.075	0.0	1.863	40.0	28.8	10.216	Yes
4	NOTL004A	4	2.500	9.000	14.075	2.5P	1.559	37.5	21.6	----	No *F
5	NOTL005A	6	2.500	9.000	14.075	0.0	1.895	40.0	25.0	8.741	Yes
6	NOTL006A	7	2.500	9.000	14.075	0.0	2.277	40.0	31.6	11.596	Yes

*F WARNING: The required GMT for non-survival cases does not meet all survival criteria.

NOTL001A: CASE 1
 80' FISHING BOAT

Damaged Compartments:
 VOID

	DISPLACEMENT LTons	DRAFT AFT ft	DRAFT FWD ft	TRIM ft	HEEL deg.	UPRIGHT GMT ft
INTACT	49	2.500	2.500	0.000	0.0	14.075
DAMAGED	49	2.476	2.556	0.080F	0.0	13.866

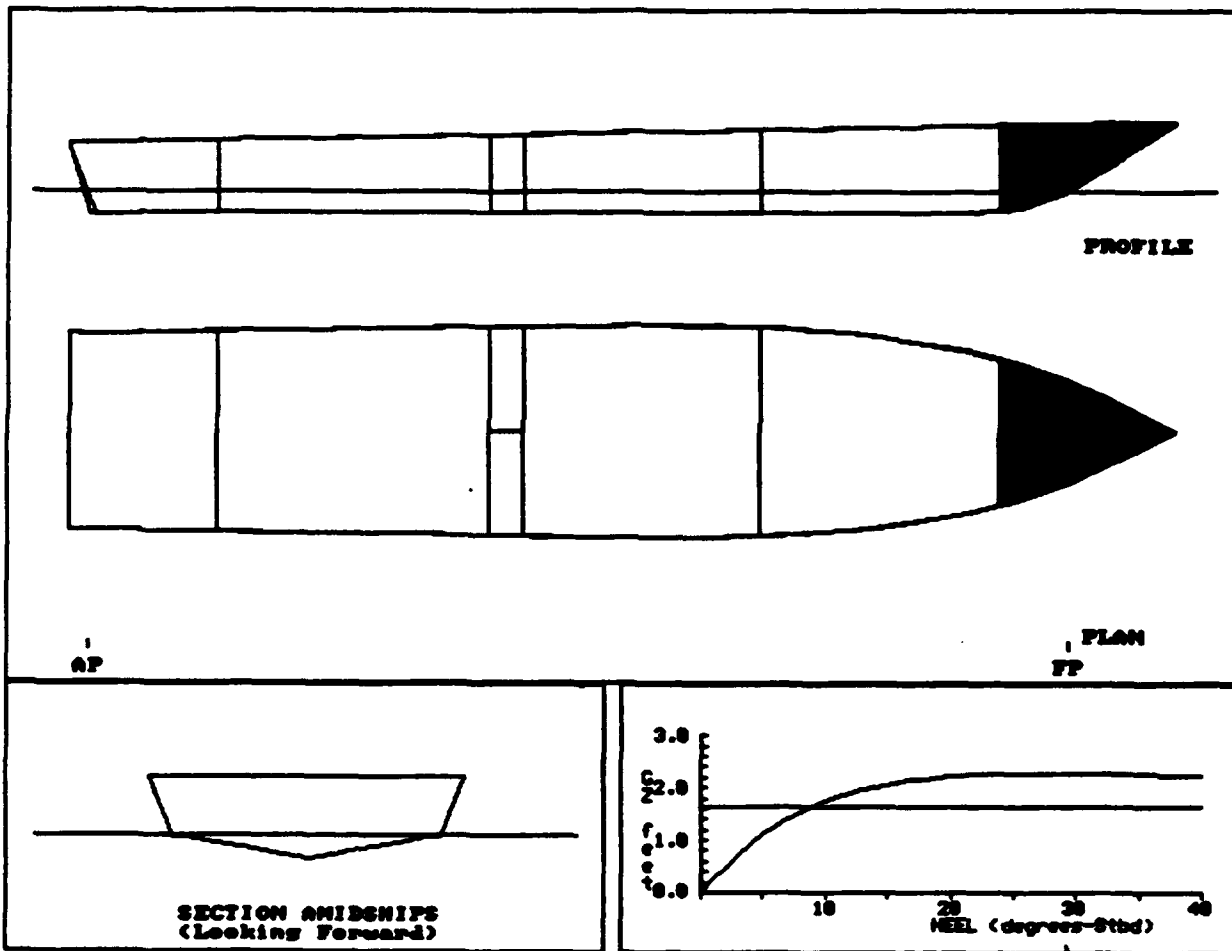

NOTL001A: CASE 1
 80' FISHING BOAT

COMPARTMENT FLOODING SUMMARY

At 0.0o Heel	PERM.	FLOODED WTR LTons	% FULL (Damaged)	% FULL (Intact)	SP.VOL. ft3/LT	OUTFLO. LTons
VOID	0.95	0	FREE	0.0	----	----
Totals		0				

INTACT DATA

Draft at AP = 2.500 ft	KMt = 23.075 ft	LCG = 46.916A ft-FP
Draft at FP = 2.500 ft	VCG = 9.000 ft	LCB = 46.916A ft-FP
Displacement = 49 LTons	GMT = 14.075 ft	TCG = 0.000 ft-CL

DRAFT/GZ DATA

HEEL degrees	RIGHTING ARM ft	DRAFT AFT ft	DRAFT FWD ft	FLOODED WATER LTons
0.0	0.000	2.476	2.556	0
5.0S	1.096	2.471	2.479	0
7.0S	1.396	2.431	2.431	0
10.0S	1.735	2.323	2.350	0
15.0S	2.061	2.033	2.196	0
20.0S	2.217	1.630	1.999	0
22.0S	2.249	1.440	1.903	0
25.0S	2.273	1.115	1.747	0
30.0S	2.275	0.488	1.409	0
35.0S	2.263	-0.280	0.970	0
40.0S	2.221	-1.199	0.321	0

Note: Drafts are measured at A.P. and F.P along ship's centerline

GZ SUMMARY (Evaluated per IMO (SOLAS'90) Rules for Passenger Ships)

	Available	Required
Static Heel Angle	0.0 deg	7.0 deg
Angle at Maximum GZ	28.0S deg	
Maximum GZ	2.277 ft	1.620 ft
Range of Positive GZ	40.0 deg	15.0 deg
Gmt (upright damaged)	13.866 ft	
Righting Area (0.0-22.0)	34.90 ft-deg	2.82 ft-deg

NOTL002A: CASE 2
 80' FISHING BOAT

Managed Compartments:
 COMPTMT1

	DISPLACEMENT LTons	DRAFT AFT ft	DRAFT FWD ft	TRIM ft	HEEL deg.	UPRIGHT GMT ft
INTACT	49	2.500	2.500	0.000	0.0	14.075
DAMAGED	58	2.066	3.838	1.772F	0.0	14.527

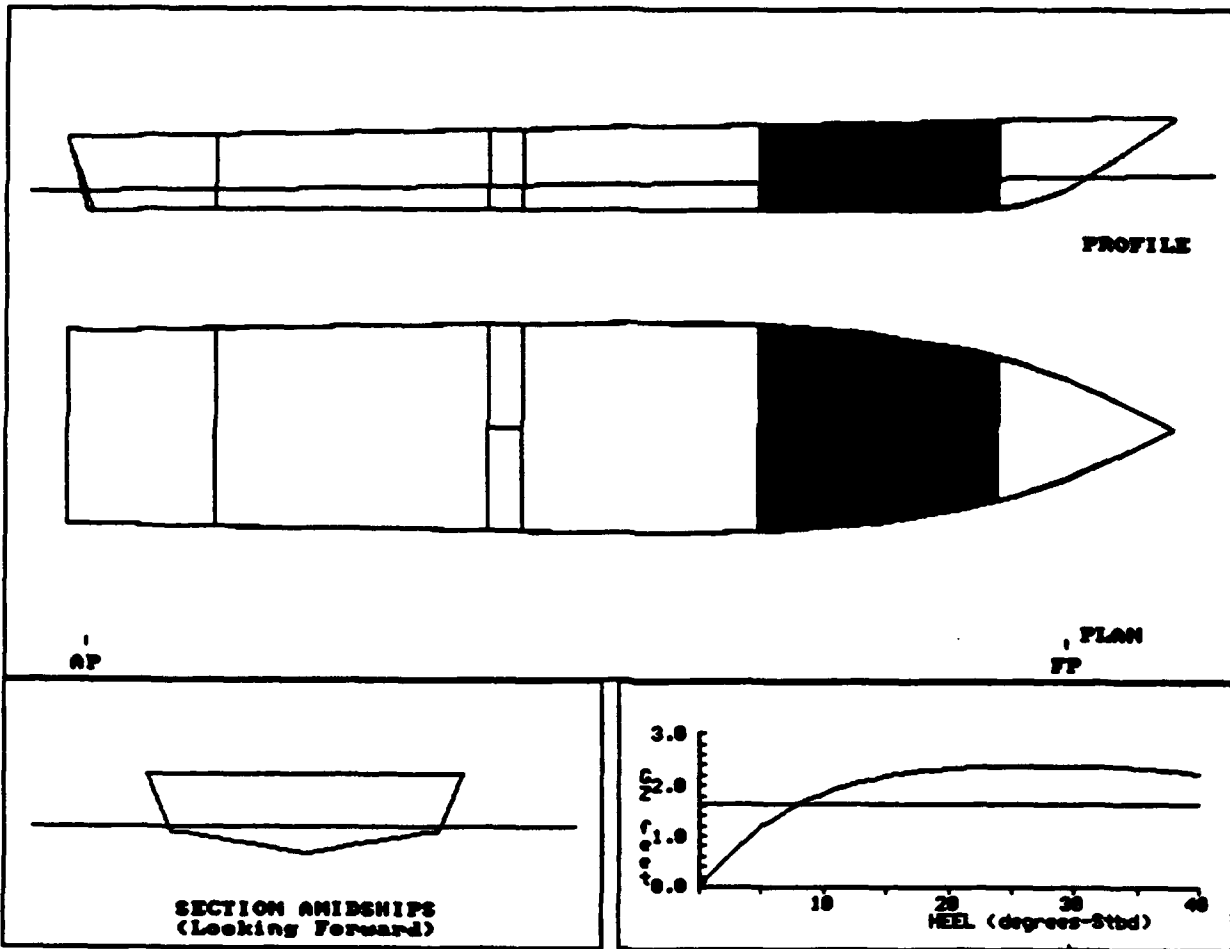

NOTL002A: CASE 2
 80' FISHING BOAT

COMPARTMENT FLOODING SUMMARY

At 0.0o Heel	PERM.	FLOODED WTR LTons	% FULL (Damaged)	% FULL (Intact)	SP.VOL. ft3/LT	OUTFLOW LTons
COMPTMT1	0.95	10	FREE	0.0	----	----
Totals		10				

INTACT DATA

Draft at AP = 2.500 ft Kmt = 23.075 ft LCG = 46.916A ft-FP
 Draft at FP = 2.500 ft VCG = 9.000 ft LCB = 46.916A ft-FP
 Displacement = 49 LTons Gmt = 14.075 ft TCG = 0.000 ft-CL

DRAFT/GZ DATA

HEEL degrees	RIGHTING ARM ft	DRAFT AFT ft	DRAFT FWD ft	FLOODED WATER LTons
0.0	0.000	2.066	3.838	10
5.0S	1.178	2.037	3.833	10
7.0S	1.489	1.985	3.810	10
10.0S	1.837	1.863	3.762	10
15.0S	2.180	1.558	3.647	9
20.0S	2.342	1.138	3.480	9
22.0S	2.374	0.943	3.392	9
25.0S	2.396	0.628	3.213	9
30.0S	2.391	-0.003	2.877	8
35.0S	2.360	-0.769	2.418	8
40.0S	2.230	-1.766	1.973	8

Note: Drafts are measured at A.P. and F.P along ship's centerline

GZ SUMMARY (Evaluated per IMO (SOLAS'90) Rules for Passenger Ships)
 Available Required

Static Heel Angle	0.0 deg	7.0 deg
Angle at Maximum GZ	27.0S deg	
Maximum GZ	2.397 ft	1.620 ft
Range of Positive GZ	40.0 deg	15.0 deg
Gmt (upright damaged)	14.527 ft	
Righting Area (0.0-22.0)	37.00 ft-deg	2.82 ft-deg

NOTL003A: CASE 3
 80' FISHING BOAT

amaged Compartments:
 COMPTNT2

	DISPLACEMENT LTons	DRAFT AFT ft	DRAFT FWD ft	TRIM ft	HEEL deg.	UPRIGHT GMT ft
INTACT	49	2.500	2.500	0.000	0.0	14.075
DAMAGED	66	2.465	3.775	1.310F	0.0	10.216

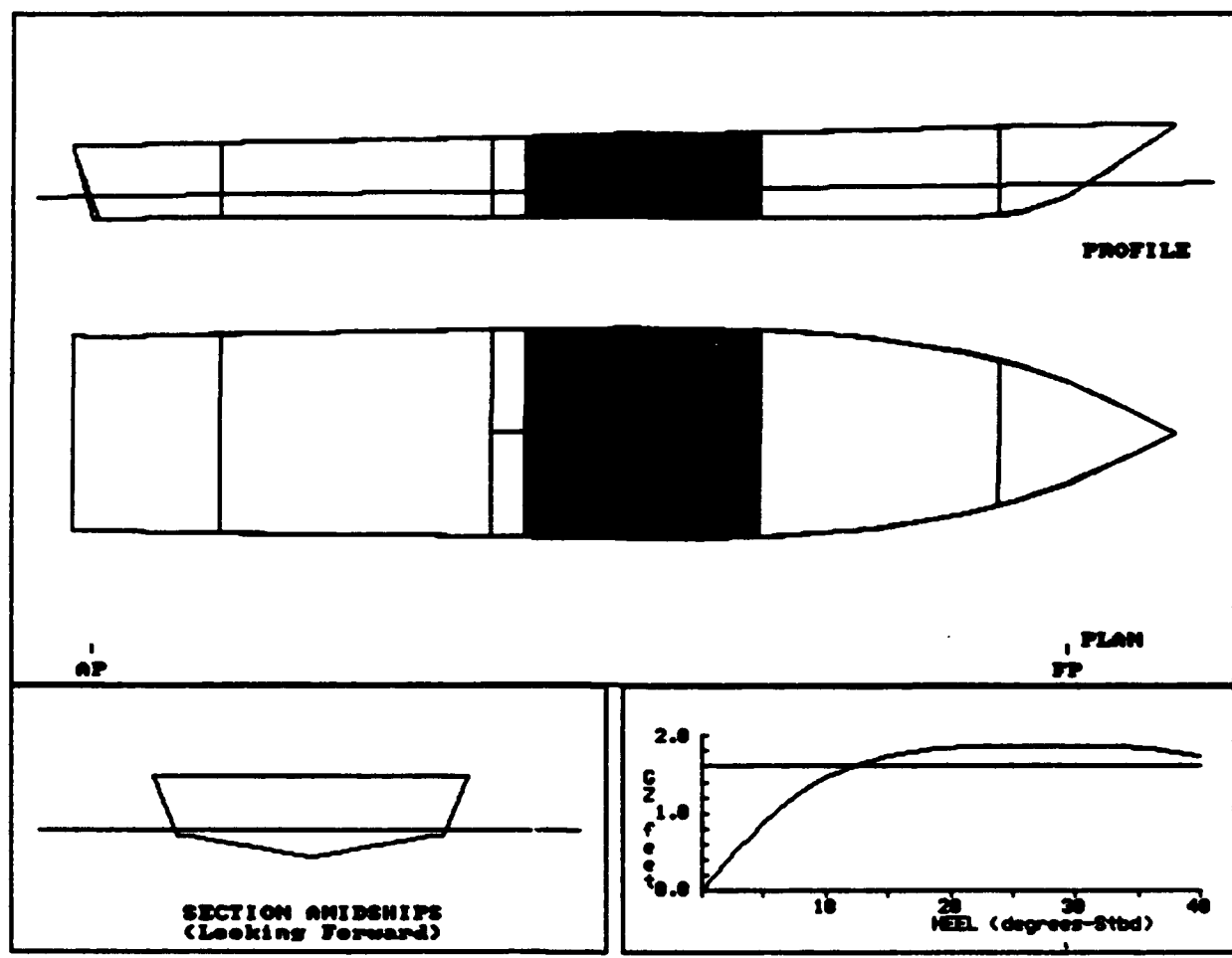

NOTLO03A: CASE 3
 80' FISHING BOAT

COMPARTMENT FLOODING SUMMARY

At 0.0o Heel	PERM.	FLOODED WTR LTons	% FULL (Damaged)	% FULL (Intact)	SP.VOL. ft3/LT	OUTFLOW LTons
COMPTMT2	0.95	17	FREE	0.0	----	----
Totals		17				

INTACT DATA

Draft at AP = 2.500 ft	Kmt = 23.075 ft	LCG = 46.916A ft-FP
Draft at FP = 2.500 ft	VCG = 9.000 ft	LCB = 46.916A ft-FP
Displacement = 49 LTons	GMT = 14.075 ft	TCG = 0.000 ft-CL

DRAFT/GZ DATA

HEEL degrees	RIGHTING ARM ft	DRAFT AFT ft	DRAFT FWD ft	FLOODED WATER LTons
0.0	0.000	2.465	3.775	17
5.0S	0.867	2.463	3.745	17
7.0S	1.152	2.435	3.736	17
10.0S	1.450	2.345	3.704	17
15.0S	1.723	2.083	3.631	18
20.0S	1.837	1.706	3.519	18
22.0S	1.854	1.523	3.463	19
25.0S	1.863	1.216	3.357	19
30.0S	1.852	0.618	3.099	19
35.0S	1.844	-0.120	2.749	20
40.0S	1.732	-0.994	2.337	20

Note: Drafts are measured at A.P. and F.P along ship's centerline

GZ SUMMARY (Evaluated per IMO (SOLAS'90) Rules for Passenger Ships)
 Available Required

Static Heel Angle	0.0 deg	7.0 deg
Angle at Maximum GZ	26.0S deg	
Maximum GZ	1.863 ft	1.620 ft
Range of Positive GZ	40.0 deg	15.0 deg
Gmt (upright damaged)	10.216 ft	
Righting Area (0.0-22.0)	28.83 ft-deg	2.82 ft-deg

NOTL004A: CASE 4
 80' FISHING BOAT

Damaged Compartments:
 FUELSTED

	DISPLACEMENT LTons	DRAFT AFT ft	DRAFT FWD ft	TRIM ft	HEEL deg.	UPRIGHT GMT ft
INTACT	49	2.500	2.500	0.000	0.0	14.075
DAMAGED	44	2.393	2.260	0.133A	2.5P	14.224

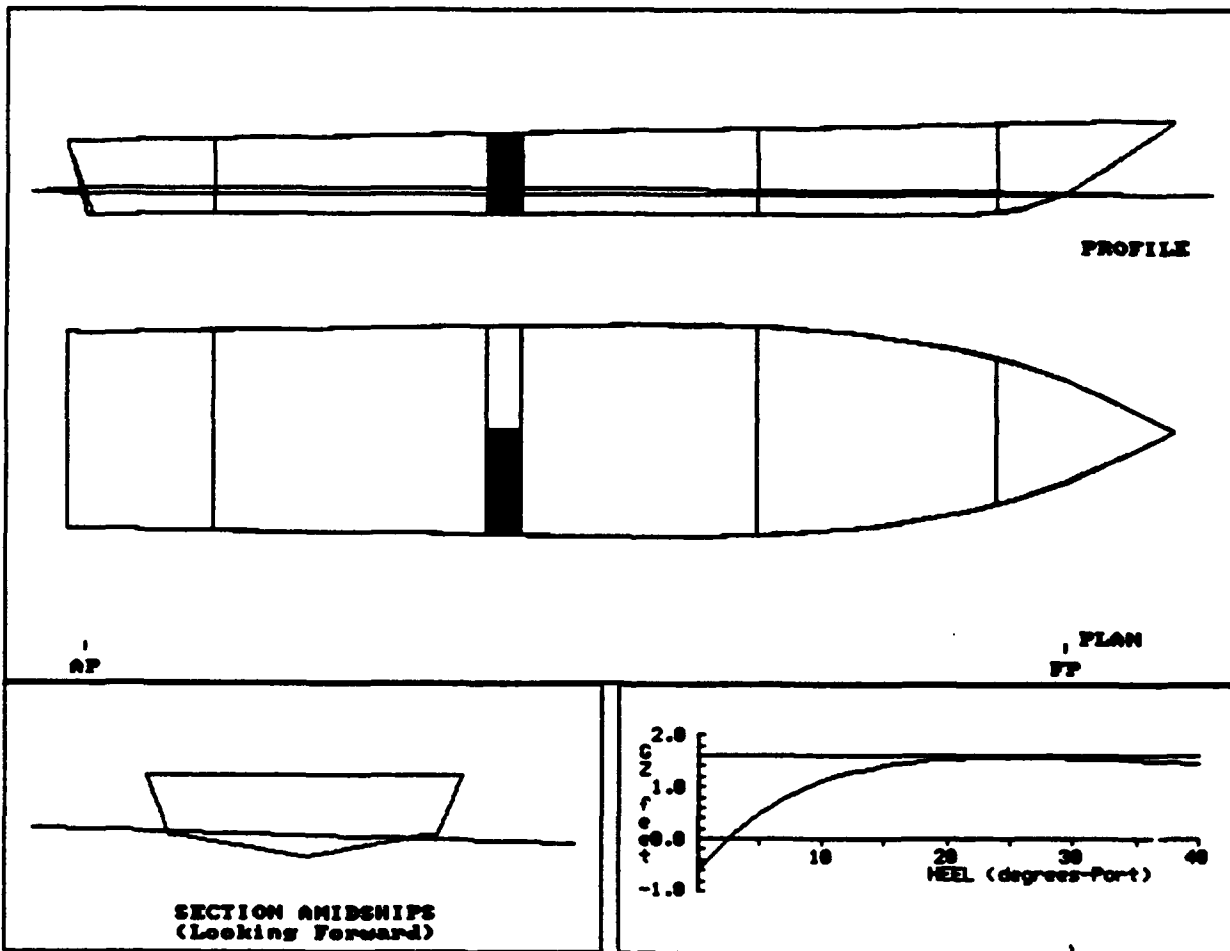

NOTL004A: CASE 4
 80' FISHING BOAT

COMPARTMENT FLOODING SUMMARY

At 2.5oP Heel	PERM.	FLOODED WTR LTons	% FULL (Damaged)	% FULL (Intact)	SP.VOL. ft3/LT	OUTFLOW LTons
FUELSTBD	0 95	1	FREE	100.0	38.5800	6
Totals		1				6

INTACT DATA

Draft at AP = 2.500 ft Kmt = 23.075 ft LCG = 46.916A ft-FP
 Draft at FP = 2.500 ft VCG = 9.000 ft LCB = 46.916A ft-FP
 Displacement = 49 LTons Gmt = 14.075 ft TCG = 0.000 ft-CL

DRAFT/GZ DATA

HEEL degrees	RIGHTING ARM ft	DRAFT AFT ft	DRAFT FWD ft	FLOODED WATER LTons
0.0	-0.608	2.398	2.301	1
5.0P	0.497	2.370	2.215	1
7.0P	0.781	2.316	2.166	1
10.0P	1.102	2.191	2.079	0
15.0P	1.400	1.873	1.916	0
20.0P	1.528	1.442	1.718	0
22.0P	1.551	1.247	1.612	0
25.0P	1.559	0.902	1.462	0
30.0P	1.544	0.246	1.132	0
35.0P	1.516	-0.550	0.700	0
40.0P	1.446	-1.508	0.046	0

Note: Drafts are measured at A.P. and F.P along ship's centerline

GZ SUMMARY (Evaluated per IMO (SOLAS'90) Rules for Passenger Ships)
 Available Required

Static Heel Angle	2.5P deg	7.0 deg
Angle at Maximum GZ	25.0P deg	
*** Maximum GZ	1.559 ft	1.620 ft
Range of Positive GZ	37.5 deg	15.0 deg
Righting Area (2.5-22.0)	21.58 ft-deg	2.82 ft-deg

*** indicates failure to meet criterion

NOTLO05A: CASE 5
 80' FISHING BOAT

anged Compartments:
 ENGINEER

	DISPLACEMENT LTons	DRAFT AFT ft	DRAFT FWD ft	TRIM ft	HEEL deg.	UPRIGHT GMT ft
INTACT	49	2.500	2.500	0.000	0.0	14.075
DAMAGED	75	3.904	2.234	1.670A	0.0	8.741

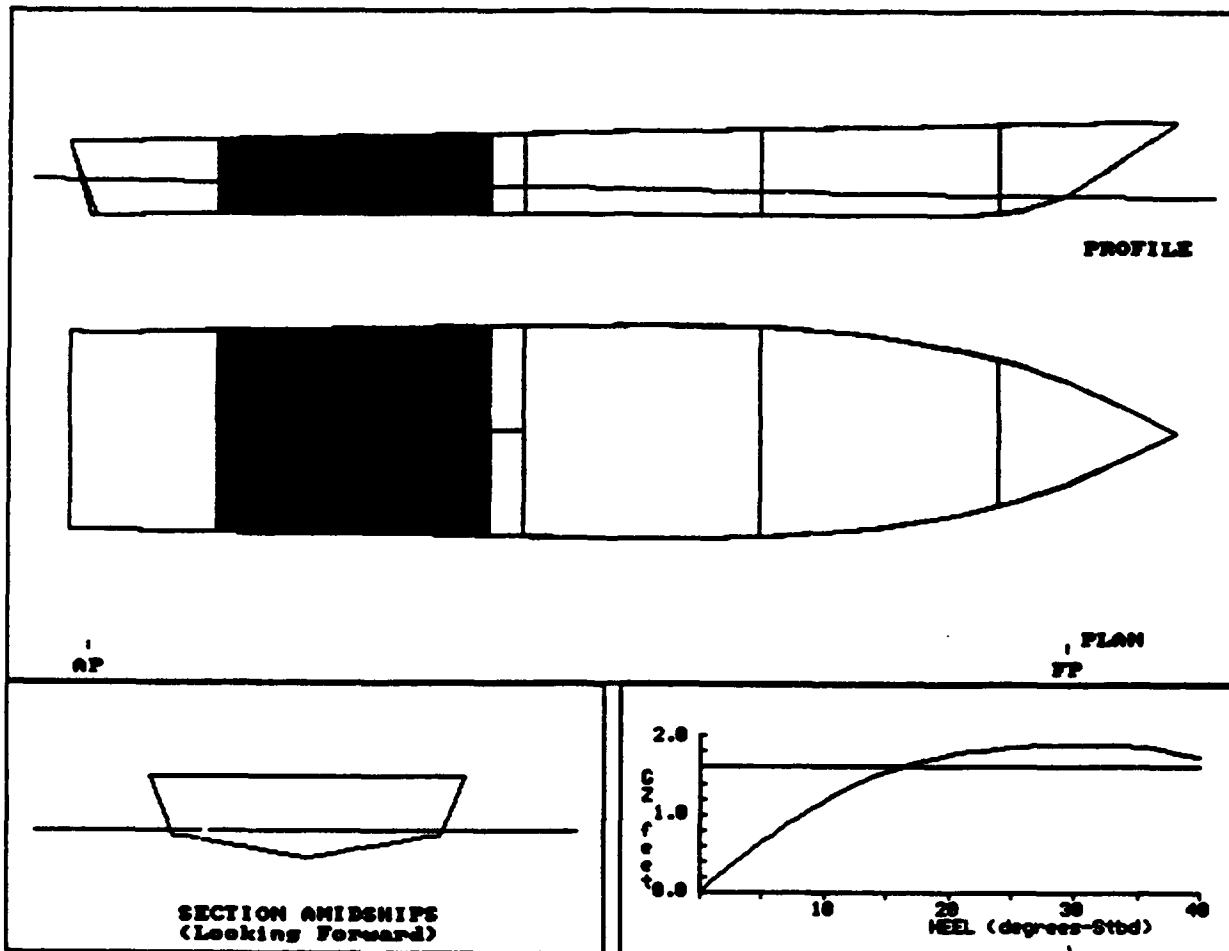

NOTLO05A: CASE 5
 80' FISHING BOAT

COMPARTMENT FLOODING SUMMARY

At 0.0o Heel	PERM.	FLOODED WTR LTons	% FULL (Damaged)	% FULL (Intact)	SP.VOL. ft ³ /LT	OUTFLOW LTons
ENGINE RM	0.85	26	FREE	0.0	----	----
Totals		26				

INTACT DATA

Draft at AP = 2.500 ft	KMt = 23.075 ft	LCG = 46.916A ft-FP
Draft at FP = 2.500 ft	VCG = 9.000 ft	LCB = 46.916A ft-FP
Displacement = 49 LTons	Gmt = 14.075 ft	TCG = 0.000 ft-CL

DRAFT/GZ DATA

HEEL degrees	RIGHTING ARM ft	DRAFT AFT ft	DRAFT FWD ft	FLOODED WATER LTons
0.0	0.000	3.904	2.234	26
5.0S	0.641	3.879	2.209	26
7.0S	0.859	3.866	2.166	26
10.0S	1.175	3.834	2.074	26
15.0S	1.545	3.708	1.873	25
20.0S	1.751	3.456	1.633	25
22.0S	1.800	3.324	1.524	25
25.0S	1.854	3.098	1.335	25
30.0S	1.891	2.659	0.930	26
35.0S	1.871	2.176	0.359	26
40.0S	1.731	1.717	-0.471	26

Note: Drafts are measured at A.P. and F.P along ship's centerline

GZ SUMMARY (Evaluated per IMO (SOLAS'90) Rules for Passenger Ships)
 Available Required

Static Heel Angle	0.0 deg	7.0 deg
Angle at Maximum GZ	33.0S deg	
Maximum GZ	1.895 ft	1.620 ft
Range of Positive GZ	40.0 deg	15.0 deg
Gmt (upright damaged)	8.741 ft	
Righting Area (0.0-22.0)	24.97 ft-deg	2.82 ft-deg

NOTL006A: CASE 6
 80' FISHING BOAT

Damaged Compartments:
 LAZARETTE

	DISPLACEMENT LTons	DRAFT AFT ft	DRAFT FWD ft	TRIM ft	HEEL deg.	UPRIGHT Gmt ft
INTACT	49	2.500	2.500	0.000	0.0	14.075
DAMAGED	67	4.211	1.088	3.123A	0.0	11.596

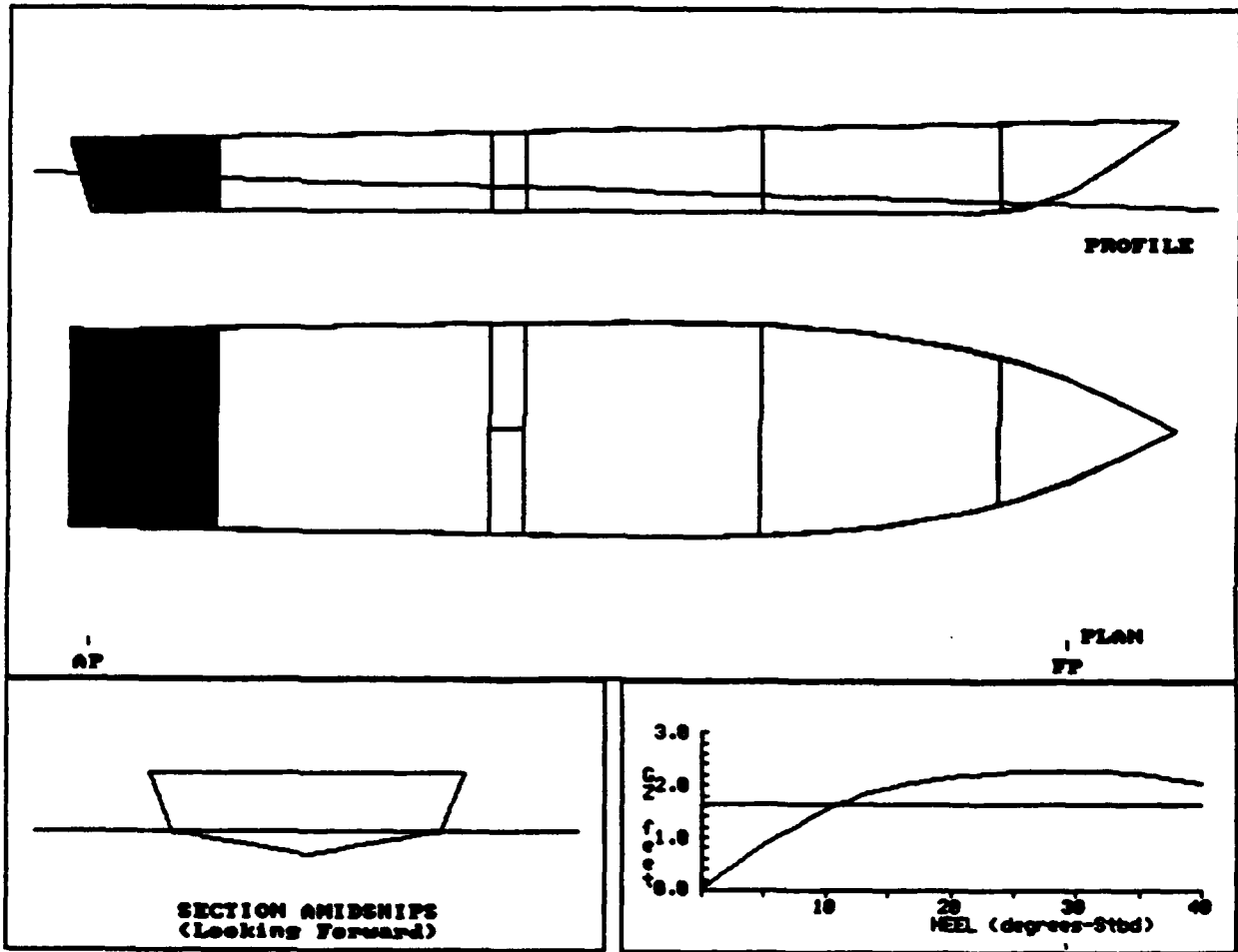

NOTL006A: CASE 6
 80' FISHING BOAT

COMPARTMENT FLOODING SUMMARY

At 0.0o Heel	PERM.	FLOODED WTR LTons	% FULL (Damaged)	% FULL (Intact)	SP.VOL. ft3/LT	OUTFLOW LTons
LAZARETTE	0.95	18	FREE	0.0	----	----
Totals		18				

INTACT DATA

Draft at AP = 2.500 ft	Kmt = 23.075 ft	LCG = 46.916A ft-FP
Draft at FP = 2.500 ft	VCG = 9.000 ft	LCB = 46.916A ft-FP
Displacement = 49 LTons	Gmt = 14.075 ft	TCG = 0.000 ft-CL

DRAFT/GZ DATA

HEEL degrees	RIGHTING ARM ft	DRAFT AFT ft	DRAFT FWD ft	FLOODED WATER LTons
0.0	0.000	4.211	1.088	18
5.0S	0.841	4.201	1.034	18
7.0S	1.129	4.200	0.969	18
10.0S	1.525	4.179	0.849	18
15.0S	1.941	4.062	0.578	18
20.0S	2.159	3.807	0.279	17
22.0S	2.207	3.666	0.151	17
25.0S	2.249	3.440	-0.096	17
30.0S	2.277	2.960	-0.544	16
35.0S	2.221	2.451	-1.222	16
40.0S	2.038	1.994	-2.250	16

Note: Drafts are measured at A.P. and F.P along ship's centerline

GZ SUMMARY (Evaluated per IMO (SOLAS'90) Rules for Passenger Ships)

	Available	Required
Static Heel Angle	0.0 deg	7.0 deg
Angle at Maximum GZ	31.0S deg	
Maximum GZ	2.277 ft	1.620 ft
Range of Positive GZ	40.0 deg	15.0 deg
Gmt (upright damaged)	11.596 ft	
Righting Area (0.0-22.0)	31.63 ft-deg	2.82 ft-deg

**APPENDIX B
HYDROSTATICS AND
DAMAGE STABILITY
OUTPUT**

59' FISHING BOAT

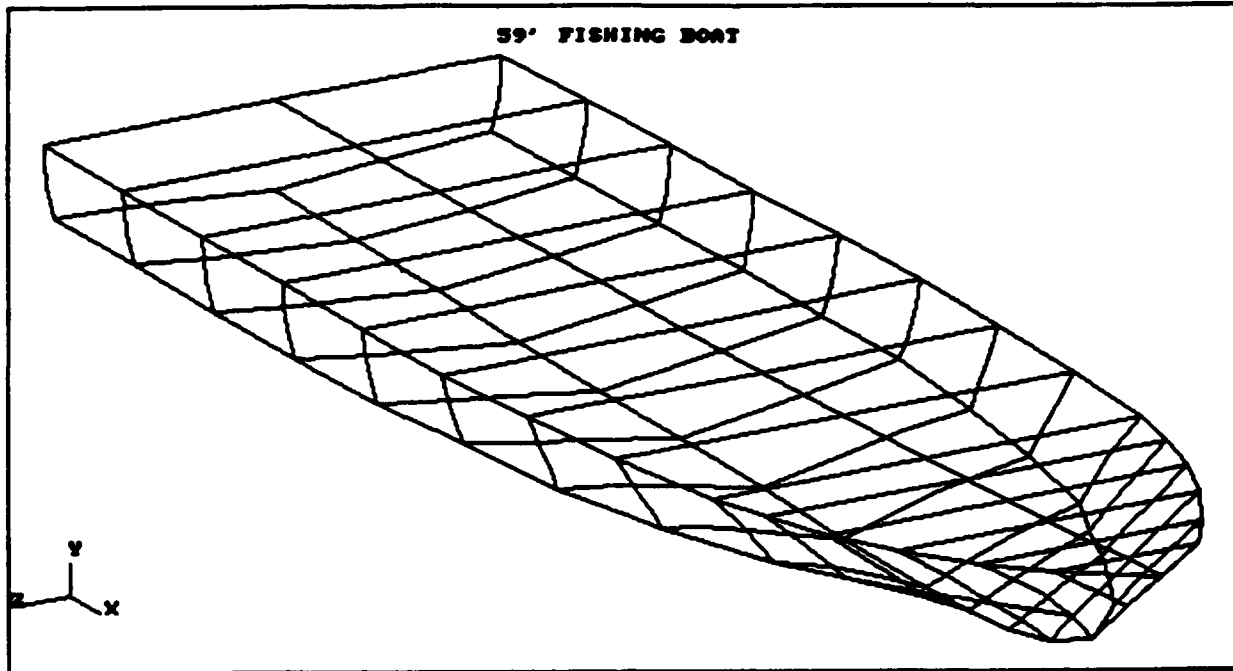

**DAMAGE STABILITY SUMMARY
 59' FISHING BOAT**

CA No.	FILE NAME	DAMAGED COMP.	LISTING	---Intact Condition---			-----Equilibrium Condition After Damage-----					
				MN.DRAFT (ft)	VCG (ft)	Gmt (ft)	HEEL (deg)	MAX.GZ (ft)	RANGE (deg)	AREA (ft-deg)	DAM.GMT (ft)	SURVIVAL
1	DPRT001A	1		3.451	9.530	8.714	0.0	1.467	47.93	23.72	8.483	Yes
2	DPRT002A	2		3.451	9.530	8.714	0.0	1.409	43.02	21.38	7.052	Yes
3	DPRT003A	3		3.451	9.530	8.714	0.0	0.905	40.03	14.50	4.727	No *F
4	DPRT004A	5		3.451	9.530	8.714	0.0	1.102	41.30	16.26	4.797	No *F
5	DPRT005A	6		3.451	9.530	8.714	0.0	1.198	42.90	17.82	5.555	No *F

*F WARNING: The required Gmt for non-survival cases does not meet all survival criteria.

**DAMAGE STABILITY SUMMARY
 59' FISHING BOAT**

Ca. No.	FILE NAME	DAMAGED COMP.	LISTING	---Intact Condition---			-----Equilibrium Condition After Damage-----						
				MIN.DRAFT (ft)	VCG (ft)	GMt (ft)	HEEL (deg)	MAX.GZ (ft)	RANGE (deg)	AREA (ft-deg)	DAM.GMt (ft)	SURVIVAL	
1	RTRN001A	1		3.236	10.520	9.778	0.0	1.251	42.76	21.58	9.490	No	*F
2	RTRN002A	2		3.236	10.520	9.778	0.0	1.191	38.24	19.20	7.191	No	*F
3	RTRN003A	3		3.236	10.520	9.778	0.0	0.723	34.80	12.21	5.118	No	*F
4	RTRN004A	5		3.236	10.520	9.778	0.0	0.911	37.21	14.72	5.106	No	*F
5	RTRN005A	6		3.236	10.520	9.778	0.0	1.015	39.07	16.41	6.008	No	*F

*F WARNING: The required GMt for non-survival cases does not meet all survival criteria.

HYDROSTATIC TABLES
 59' FISHING BOAT

MOLDED DRAFT (ft)		2.200	2.600	3.000	3.400	3.800	4.200	4.600	5.000	5.400
DISP.MLD. (LTons-SW)		13.9	22.5	32.3	42.8	53.5	64.4	75.4	86.7	98.1
DISP.TOTAL (LTons-SW)		14.3	23.0	33.0	43.5	54.3	65.2	76.4	87.7	99.2
DISP.TOTAL (LTons-FW)		14.0	22.5	32.2	42.4	52.9	63.6	74.5	85.6	96.8
LCB (ft-FP)		32.214A	33.591A	34.053A	34.105A	34.056A	33.977A	33.882A	33.776A	33.660A
LCB (forebody) (ft-FP)		18.580A	18.674A	18.725A	18.690A	18.593A	18.482A	18.368A	18.250A	18.130A
LCB (aftbody) (ft-FP)		42.734A	43.522A	43.819A	43.939A	44.010A	44.057A	44.090A	44.114A	44.131A
TCB (ft-CL)		0.000	0.000	0.000	0.000	0.000	0.000	0.000	0.000	0.000
KB (ft)		1.660	1.939	2.199	2.442	2.672	2.895	3.115	3.333	3.549
BMT (ft)		19.754	23.947	19.900	15.891	13.146	11.275	9.916	8.867	8.052
KMT (ft)		21.413	25.887	22.099	18.332	15.817	14.170	13.031	12.199	11.602
BML (ft)		280.875	221.711	172.327	139.318	116.288	100.098	88.313	79.345	72.322
KML (ft)		282.534	223.650	174.526	141.760	118.960	102.993	91.428	82.678	75.871
	(LTons)	1.57	1.96	2.14	2.20	2.25	2.29	2.32	2.36	2.39
	(ft-LTons)	5.5	7.0	7.9	8.4	8.8	9.1	9.4	9.7	10.0
	(LTons)	0.16	0.20	0.18	0.17	0.16	0.15	0.14	0.14	0.13
LCF (ft-FP)		35.560A	35.735A	34.579A	34.028A	33.724A	33.474A	33.226A	32.959A	32.696A
W.P. AREA (ft2)		658.7	824.5	896.9	925.9	943.8	960.0	975.7	990.6	1,005.7
WETTED SUR. (ft2)		696.5	879.3	983.5	1,052.4	1,112.6	1,171.7	1,231.0	1,290.6	1,350.5
MAX. BEAM (ft)		15.430	18.866	18.983	19.099	19.216	19.333	19.445	19.547	19.648
LENGTH W.L. (ft)		58.140	58.856	59.316	59.622	59.927	60.233	60.539	60.844	61.150
Cb		0.1874	0.2561	0.3192	0.3725	0.4166	0.4536	0.4854	0.5131	0.5377
Cb (forebody)		0.1632	0.2047	0.2484	0.2902	0.3263	0.3576	0.3852	0.4102	0.4331
Cb (aftbody)		0.2115	0.3075	0.3899	0.4549	0.5069	0.5496	0.5855	0.6160	0.6423
Cm		0.2603	0.3528	0.4319	0.4931	0.5420	0.5822	0.6159	0.6445	0.6693
Cp		0.7200	0.7259	0.7390	0.7555	0.7686	0.7791	0.7881	0.7961	0.8034
Cwp		0.5571	0.6972	0.7584	0.7830	0.7982	0.8118	0.8251	0.8377	0.8505
Cit		0.2443	0.4783	0.5717	0.6038	0.6243	0.6444	0.6642	0.6824	0.7014

Assumes: See Water at 35.0063 ft3/LT
 Fresh Water at 35.8814 ft3/LT
 Ship floating at even keel (no heel or trim)

**DAMAGE STABILITY SUMMARY
 59' FISHING BOAT**

CA. No.	FILE NAME	DAMAGED COMP. LISTING	---Intact Condition---			-----Equilibrium Condition After Damage-----					
			MIN.DRAFT (ft)	VCG (ft)	Ght (ft)	HEEL (deg)	MAX.GZ (ft)	RANGE (deg)	AREA (ft-deg)	DAM.Ght (ft)	SURVIVAL
1	DPTA001A	1	3.451	8.400	9.844	0.0	1.913	50.00	28.43	9.612	Yes
2	DPTA002A	2	3.451	8.400	9.844	0.0	1.817	50.00	26.16	8.199	Yes
3	DPTA003A	3	3.451	8.400	9.844	0.0	1.306	50.00	19.22	5.856	Yes
4	DPTA004A	5	3.451	8.400	9.844	0.0	1.516	50.00	20.99	5.928	Yes
5	DPTA005A	6	3.451	8.400	9.844	0.0	1.619	50.00	22.56	6.689	Yes

**DAMAGE STABILITY SUMMARY
 59' FISHING BOAT**

CA. No.	FILE NAME	DAMAGED COMP.	LISTING	---Intact Condition---			-----Equilibrium Condition After Damage-----					
				MIN.DRAFT (ft)	VCG (ft)	GMt (ft)	HEEL (deg)	MAX.GZ (ft)	RANGE (deg)	AREA (ft-deg)	DAM.GMt (ft)	SURVIVAL
1	RTNA001A	1		3.236	9.210	11.088	0.0	1.657	50.00	27.04	10.800	Yes
2	RTNA002A	2		3.236	9.210	11.088	0.0	1.623	47.31	24.75	8.570	Yes
3	RTNA003A	3		3.236	9.210	11.088	0.0	1.073	45.26	17.68	6.427	No *F
4	RTNA004A	5		3.236	9.210	11.088	0.0	1.335	47.20	20.18	6.418	No *F
5	RTNA005A	6		3.236	9.210	11.088	0.0	1.454	48.96	21.89	7.327	Yes

*F WARNING: The required GMt for non-survival cases does not meet all survival criteria.

DPRTO01A:
 59' FISHING BOAT

Damaged Compartments:
 FOREPEAK

	DISPLACEMENT LTons	DRAFT AFT ft	DRAFT FWD ft	TRIM ft	HEEL deg.	UPRIGHT GMT ft
INTACT	44.0	3.237	3.664	0.427F	0.00	8.714
DAMAGED	44.4	3.193	3.759	0.566F	0.00	8.483

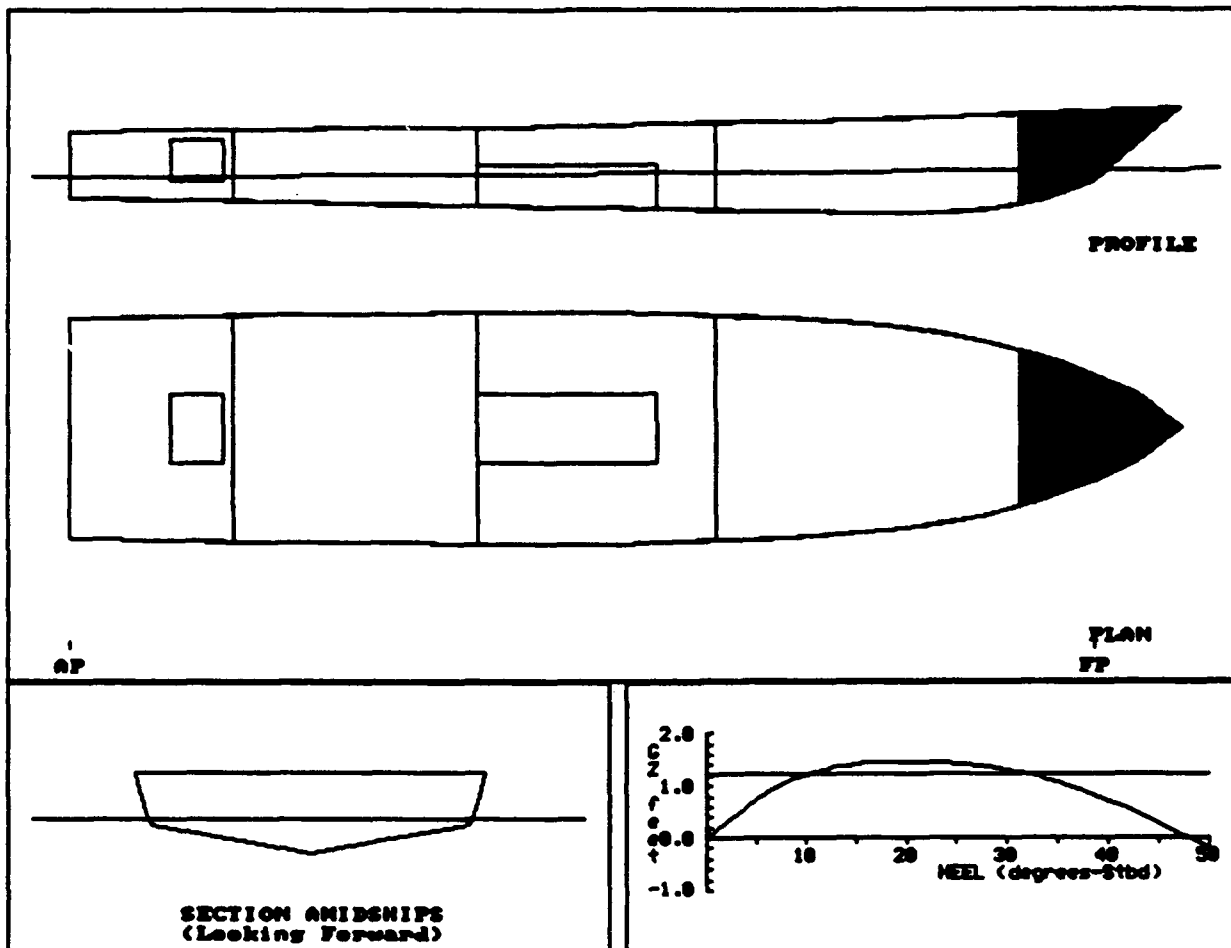

**DPRT001A:
 59' FISHING BOAT**

COMPARTMENT FLOODING SUMMARY

At 0.0o Heel	PERM.	FLOODED WTR LTons	% FULL (Damaged)	% FULL (Intact)	SP.VOL. ft3/LT	OUTFLOW LTons
FOREPEAK	0.95	0.4	FREE	0.0	----	----
Totals		0.4				

INTACT DATA

Draft at AP = 3.237 ft Kmt = 18.244 ft LCG = 33.147A ft-FP
 Draft at FP = 3.664 ft VCG = 9.530 ft LCB = 33.096A ft-FP
 Displacement = 44.0 LTons GMT = 8.714 ft TCG = 0.000 ft-CL

DRAFT/GZ DATA

HEEL degrees	RIGHTING ARM ft	DRAFT AFT ft	DRAFT FWD ft	FLOODED WATER LTons
0.00	0.000	3.193	3.759	0.4
5.00S	0.734	3.197	3.730	0.4
10.00S	1.211	3.104	3.664	0.4
20.00S	1.467	2.569	3.398	0.3
30.00S	1.311	1.654	2.913	0.2
40.00S	0.720	0.484	2.229	0.1
50.00S	-0.198	-1.070	1.334	0.1

Note: Drafts are measured at A.P. and F.P along ship's centerline

GZ SUMMARY (Evaluated per IMO (SOLAS'90) Rules for Passenger Ships)

	Available	Required
Static Heel Angle	0.00 deg	7.00 deg
Angle at Maximum GZ	21.00S deg	
Maximum GZ	1.467 ft	1.240 ft
Range of Positive GZ	47.93 deg	15.00 deg
Gmt (upright damaged)	8.483 ft	
Righting Area (0.00-%.00)	23.718 ft-deg	2.820 ft-deg

DPRT002A:
 59' FISHING BOAT

Damaged Compartments:
 COMPT 2

	DISPLACEMENT LTons	DRAFT AFT ft	DRAFT FWD ft	TRIM ft	HEEL deg.	UPRIGHT GMT ft
INTACT	44.0	3.237	3.664	0.427F	0.00	8.714
DAMAGED	68.8	2.244	6.884	4.640F	0.00	7.052

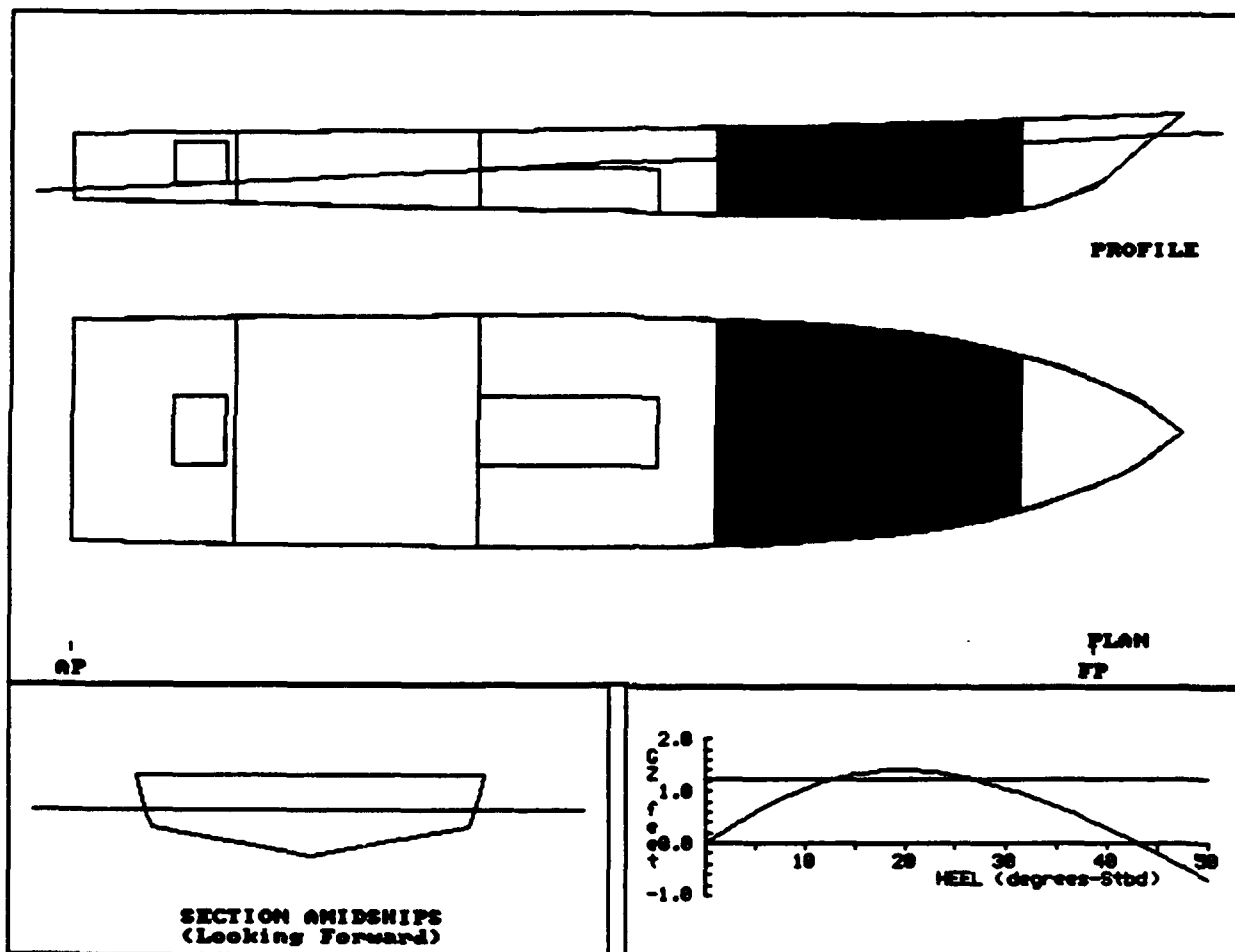

DPRT002A:
 59' FISHING BOAT

COMPARTMENT FLOODING SUMMARY

At 0.0o Heel	PERM.	FLOODED WTR LTons	% FULL (Damaged)	% FULL (Intact)	SP.VOL. ft3/LT	OUTFLOW LTons
COMPT 2	0.95	24.8	FREE	0.0	----	----
Totals		24.8				

INTACT DATA

Draft at AP = 3.237 ft	Kmt = 18.244 ft	LCG = 33.147A ft-FP
Draft at FP = 3.664 ft	VCG = 9.530 ft	LCB = 33.096A ft-FP
Displacement = 44.0 LTons	GMT = 8.714 ft	TCG = 0.000 ft-CL

DRAFT/GZ DATA

HEEL degrees	RIGHTING ARM ft	DRAFT AFT ft	DRAFT FWD ft	FLOODED WATER LTons
0.00	0.000	2.244	6.884	24.8
5.00S	0.588	2.197	6.907	25.0
10.00S	1.048	2.039	6.970	25.4
20.00S	1.409	1.398	7.030	25.6
30.00S	1.059	0.339	7.226	25.0
40.00S	0.284	-1.148	7.694	24.7
50.00S	-0.689	-3.199	8.430	24.5

Note: Drafts are measured at A.P. and F.P along ship's centerline

GZ SUMMARY (Evaluated per IMO (SOLAS'90) Rules for Passenger Ships)
 Available Required

Static Heel Angle	0.00 deg	7.00 deg
Angle at Maximum GZ	21.00S deg	
Maximum GZ	1.409 ft	1.240 ft
Range of Positive GZ	43.02 deg	15.00 deg
Gmt (upright damaged)	7.052 ft	
Righting Area (0.00-%.00)	21.384 ft-deg	2.820 ft-deg

DPERT003A:
 59' FISHING BOAT

Imaged Compartments:
 COMPT 3

	DISPLACEMENT LTons	DRAFT AFT ft	DRAFT FWD ft	TRIM ft	HEEL deg.	UPRIGHT GMT ft
INTACT	44.0	3.237	3.664	0.427F	0.00	8.714
DAMAGED	54.2	3.371	4.353	0.982F	0.00	4.727

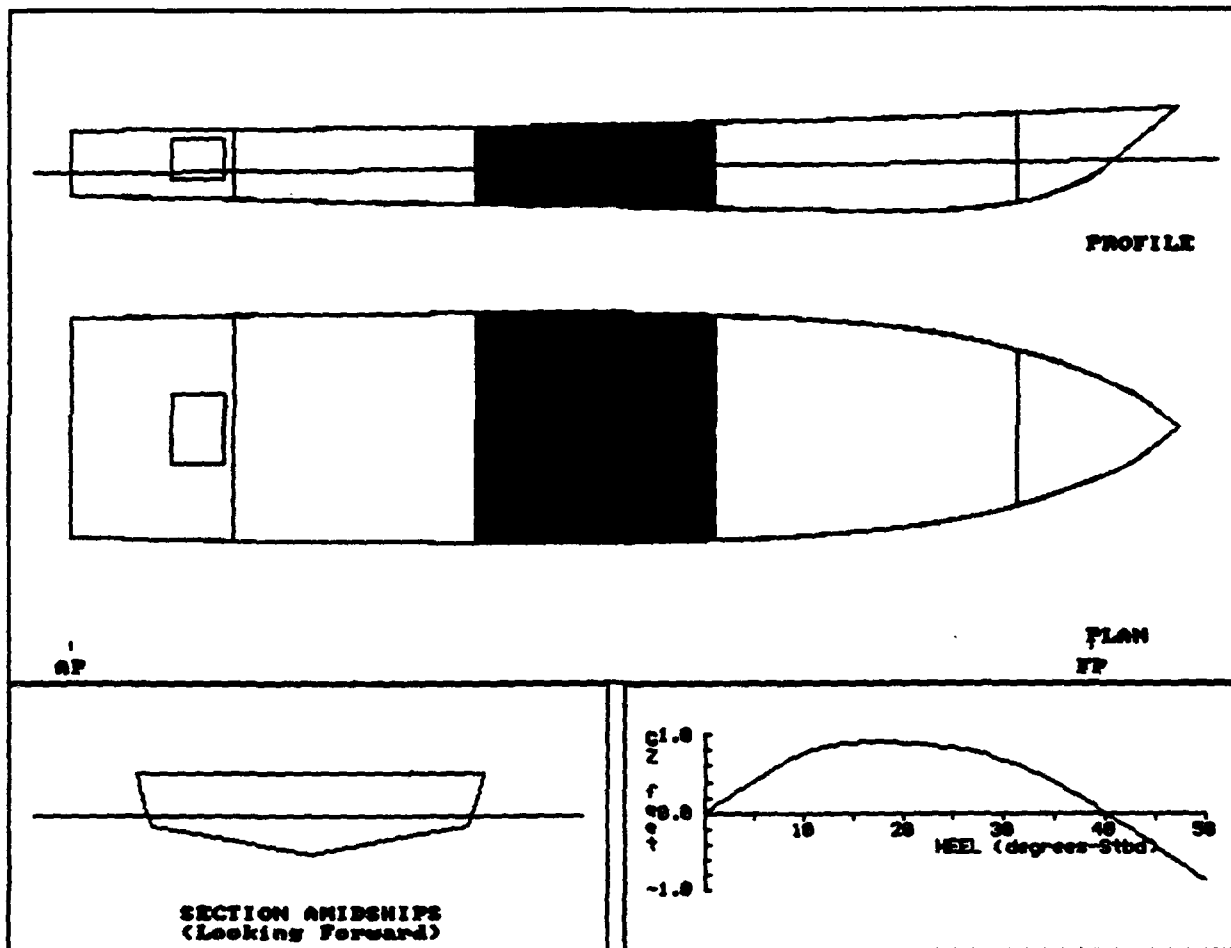

DPRT003A:
 59' FISHING BOAT

COMPARTMENT FLOODING SUMMARY

At 0.0o Heel	PERM.	FLOODED WTR LTons	% FULL (Damaged)	% FULL (Intact)	SP.VOL. ft ³ /LT	OUTFLOW LTons
COMPT 3	0.95	10.2	FREE	0.0	----	----
Totals		10.2				

INTACT DATA

Draft at AP = 3.237 ft	KMt = 18.244 ft	LCG = 33.147A ft-FP
Draft at FP = 3.664 ft	VCG = 9.530 ft	LCB = 33.096A ft-FP
Displacement = 44.0 LTons	GMt = 8.714 ft	TCG = 0.000 ft-CL

DRAFT/GZ DATA

HEEL degrees	RIGHTING ARM ft	DRAFT AFT ft	DRAFT FWD ft	FLOODED WATER LTons
0.00	0.000	3.371	4.353	10.2
5.00S	0.416	3.369	4.337	10.2
10.00S	0.754	3.317	4.307	10.3
20.00S	0.893	2.892	4.148	11.2
30.00S	0.671	2.169	3.824	12.4
40.00S	0.003	1.359	3.387	13.1
50.00S	-0.884	0.328	2.812	13.7

Note: Drafts are measured at A.P. and F.P along ship's centerline

GZ SUMMARY (Evaluated per IMO (SOLAS'90) Rules for Passenger Ships)

	Available	Required
Static Heel Angle	0.00 deg	7.00 deg
Angle at Maximum GZ	18.00S deg	
*** Maximum GZ	0.905 ft	1.240 ft
Range of Positive GZ	40.03 deg	15.00 deg
Gmt (upright damaged)	4.727 ft	
Righting Area (0.00- $\frac{1}{2}$.00)	14.503 ft-deg	2.820 ft-deg

*** indicates failure to meet criterion

**DPRT004A:
 59' FISHING BOAT**

Damaged Compartments:
 COMPT 4 ER

	DISPLACEMENT LTons	DRAFT AFT ft	DRAFT FWD ft	TRIM ft	HEEL deg.	UPRIGHT GMT ft
INTACT	44.0	3.237	3.664	0.427F	0.00	8.714
DAMAGED	59.9	4.429	3.440	0.990A	0.00	4.797

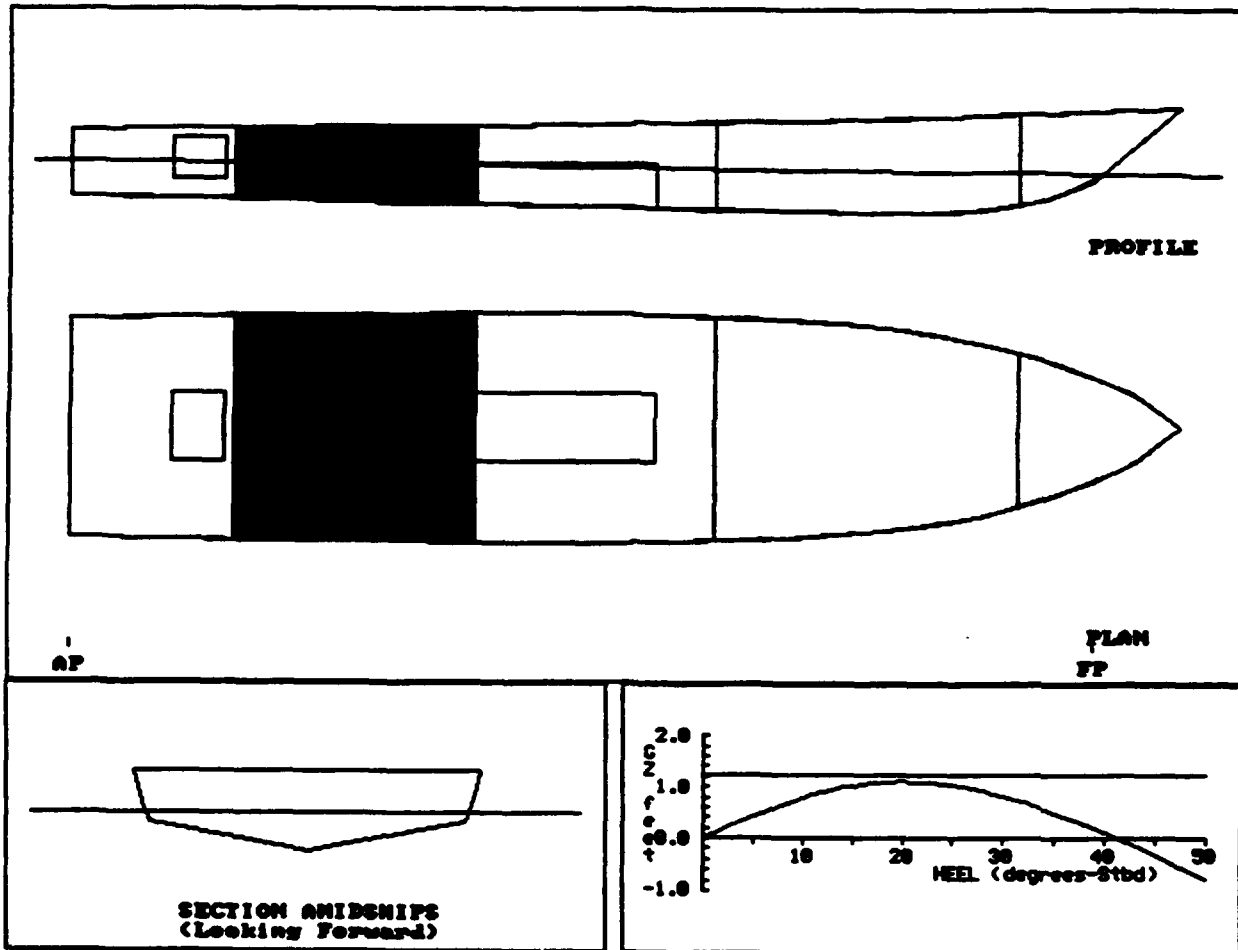

DPRT004A:
 59' FISHING BOAT

COMPARTMENT FLOODING SUMMARY

At 0.0o Heel	PERM.	FLOODED WTR LTons	% FULL (Damaged)	% FULL (Intact)	SP.VOL. ft ³ /LT	OUTFLOW LTons
COMPT 4 ER	0.85	15.9	FREE	0.0	----	----
Totals		15.9				

INTACT DATA

Draft at AP = 3.237 ft	Kmt = 18.244 ft	LCG = 33.147A ft-FP
Draft at FP = 3.664 ft	VCG = 9.530 ft	LCB = 33.096A ft-FP
Displacement = 44.0 LTons	Gmt = 8.714 ft	TCG = 0.000 ft-CL

DRAFT/GZ DATA

HEEL degrees	RIGHTING ARM ft	DRAFT AFT ft	DRAFT FWD ft	FLOODED WATER LTons
0.00	0.000	4.429	3.440	15.9
5.00S	0.418	4.432	3.418	15.9
10.00S	0.788	4.420	3.342	15.8
20.00S	1.102	4.221	2.970	15.8
30.00S	0.817	3.932	2.300	15.7
40.00S	0.111	3.713	1.354	15.6
50.00S	-0.789	3.474	0.120	15.6

Note: Drafts are measured at A.P. and F.P along ship's centerline

GZ SUMMARY (Evaluated per IMO (SOLAS'90) Rules for Passenger Ships)

	Available	Required
Static Heel Angle	0.00 deg	7.00 deg
Angle at Maximum GZ	21.00S deg	
*** Maximum GZ	1.102 ft	1.240 ft
Range of Positive GZ	41.30 deg	15.00 deg
Gmt (upright damaged)	4.797 ft	
Righting Area (0.00-%.00)	16.264 ft-deg	2.820 ft-deg

*** indicates failure to meet criterion

DPR005A:
 59' FISHING BOAT

Imaged Compartments:
 COMPT 5

	DISPLACEMENT LTons	DRAFT AFT ft	DRAFT FWD ft	TRIM ft	HEEL deg.	UPRIGHT GMT ft
INTACT	44.0	3.237	3.664	0.427F	0.00	8.714
DAMAGED	56.4	4.814	2.599	2.215A	0.00	5.555

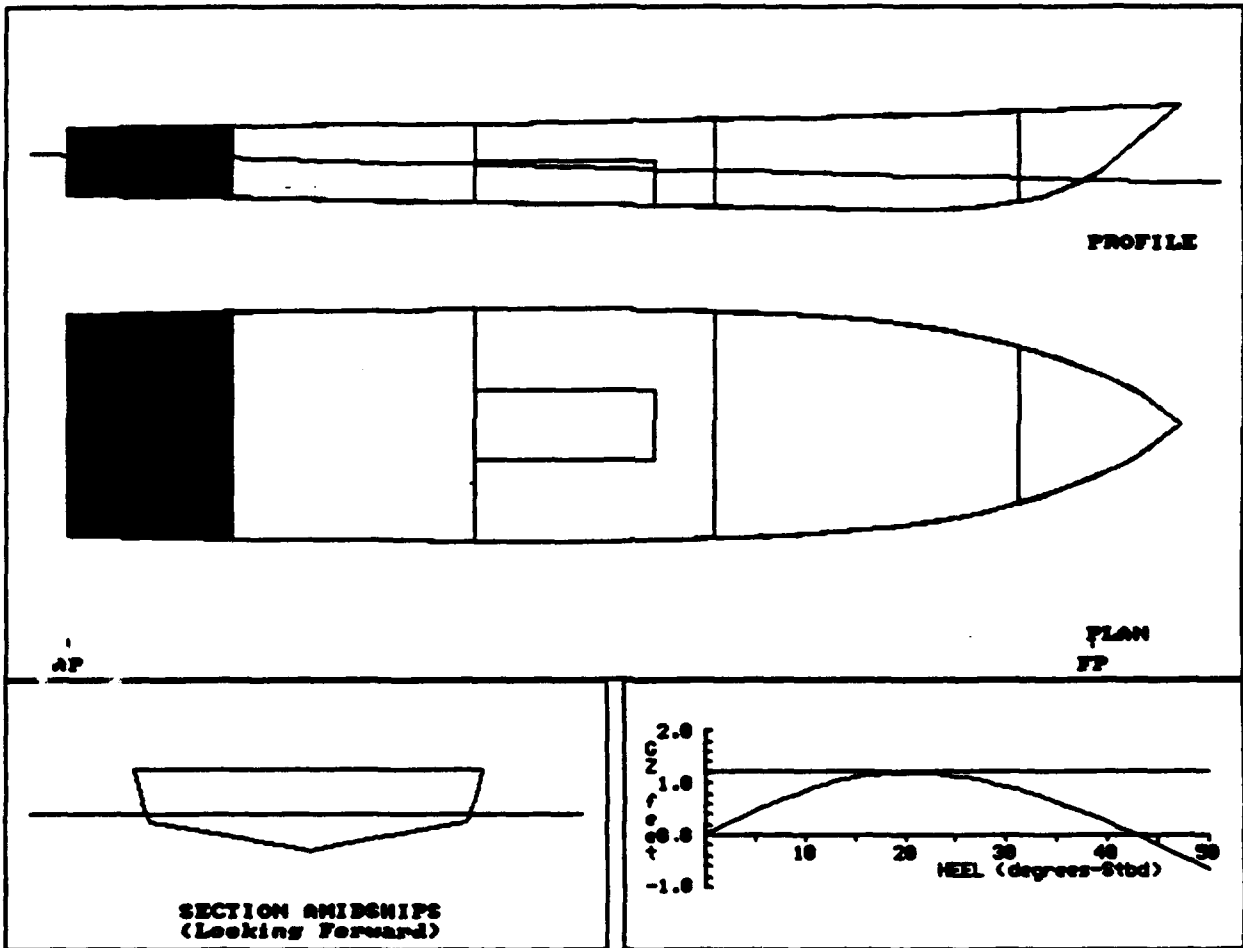

**RTRN001A:
 59' FISHING BOAT**

**aged Compartments:
 FOREPEAK**

	DISPLACEMENT LTons	DRAFT AFT ft	DRAFT FWD ft	TRIM ft	HEEL deg.	UPRIGHT GMT ft
INTACT	38.0	2.955	3.516	0.561F	0.00	9.778
DAMAGED	38.4	2.917	3.599	0.682F	0.00	9.490

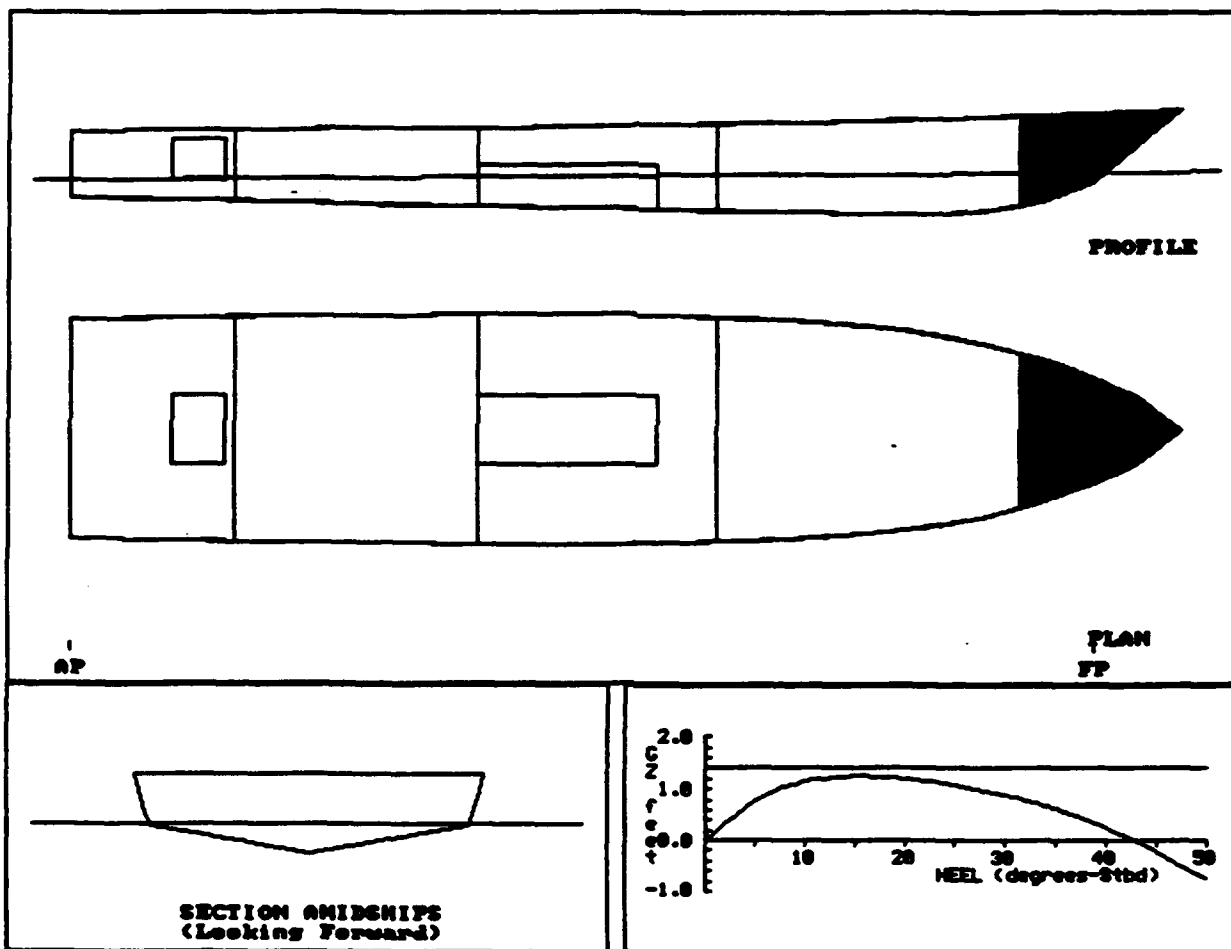

RTRN002A:
 59' FISHING BOAT

Imaged Compartments:
 COMPT 2

	DISPLACEMENT LTons	DRAFT AFT ft	DRAFT FWD ft	TRIM ft	HEEL deg.	UPRIGHT GMT ft
INTACT	38.0	2.955	3.516	0.561F	0.00	9.778
DAMAGED	60.5	2.003	6.542	4.539F	0.00	7.191

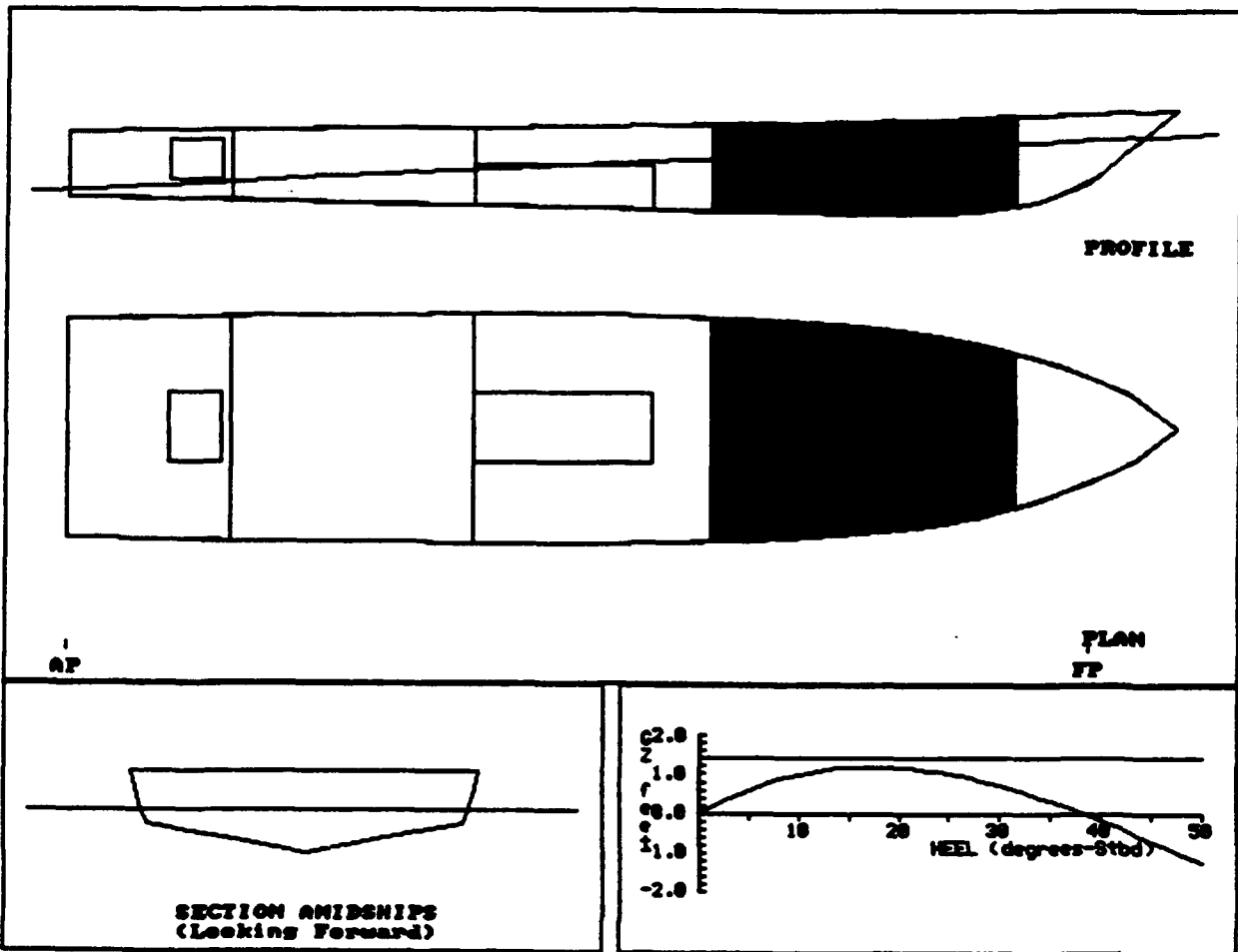

RTRN002A:
 59' FISHING BOAT

COMPARTMENT FLOODING SUMMARY

At 0.0o Heel	PERM.	FLOODED WTR LTons	% FULL (Damaged)	% FULL (Intact)	SP.VOL. ft3/LT	OUTFLOW LTons
COMPT 2	0.95	22.5	FREE	0.0	----	----
Totals		22.5				

INTACT DATA

Draft at AP = 2.955 ft	KMt = 20.298 ft	LCG = 32.682A ft-FP
Draft at FP = 3.516 ft	VCG = 10.520 ft	LCB = 32.604A ft-FP
Displacement = 38.0 LTons	GMT = 9.778 ft	TCG = 0.000 ft-CL

DRAFT/GZ DATA

HEEL degrees	RIGHTING ARM ft	DRAFT AFT ft	DRAFT FWD ft	FLOODED WATER LTons
0.00	0.000	2.003	6.542	22.5
5.00S	0.584	1.927	6.587	22.8
10.00S	0.984	1.715	6.679	23.2
20.00S	1.169	0.975	6.729	23.6
30.00S	0.710	-0.199	6.803	23.1
40.00S	-0.177	-1.861	7.092	22.7
50.00S	-1.266	-4.217	7.627	22.4

Note: Drafts are measured at A.P. and F.P along ship's centerline

GZ SUMMARY (Evaluated per IMO (SOLAS'90) Rules for Passenger Ships)
 Available Required

Static Heel Angle	0.00 deg	7.00 deg
Angle at Maximum GZ	18.00S deg	
*** Maximum GZ	1.191 ft	1.410 ft
Range of Positive GZ	38.24 deg	15.00 deg
Gmt (upright damaged)	7.191 ft	
Righting Area (0.00-%.00)	19.198 ft-deg	2.820 ft-deg

*** indicates failure to meet criterion

RTRN003A:
 59' FISHING BOAT

Unaged Compartments:
 COMPT 3

	DISPLACEMENT LTons	DRAFT AFT ft	DRAFT FWD ft	TRIM ft	HEEL deg.	UPRIGHT GMT ft
INTACT	38.0	2.955	3.516	0.561F	0.00	9.778
DAMAGED	46.7	3.062	4.129	1.066F	0.00	5.118

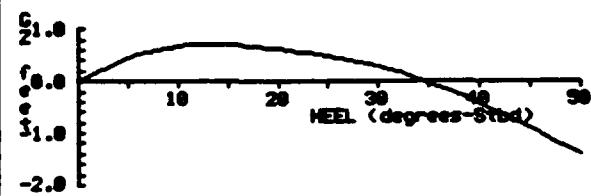
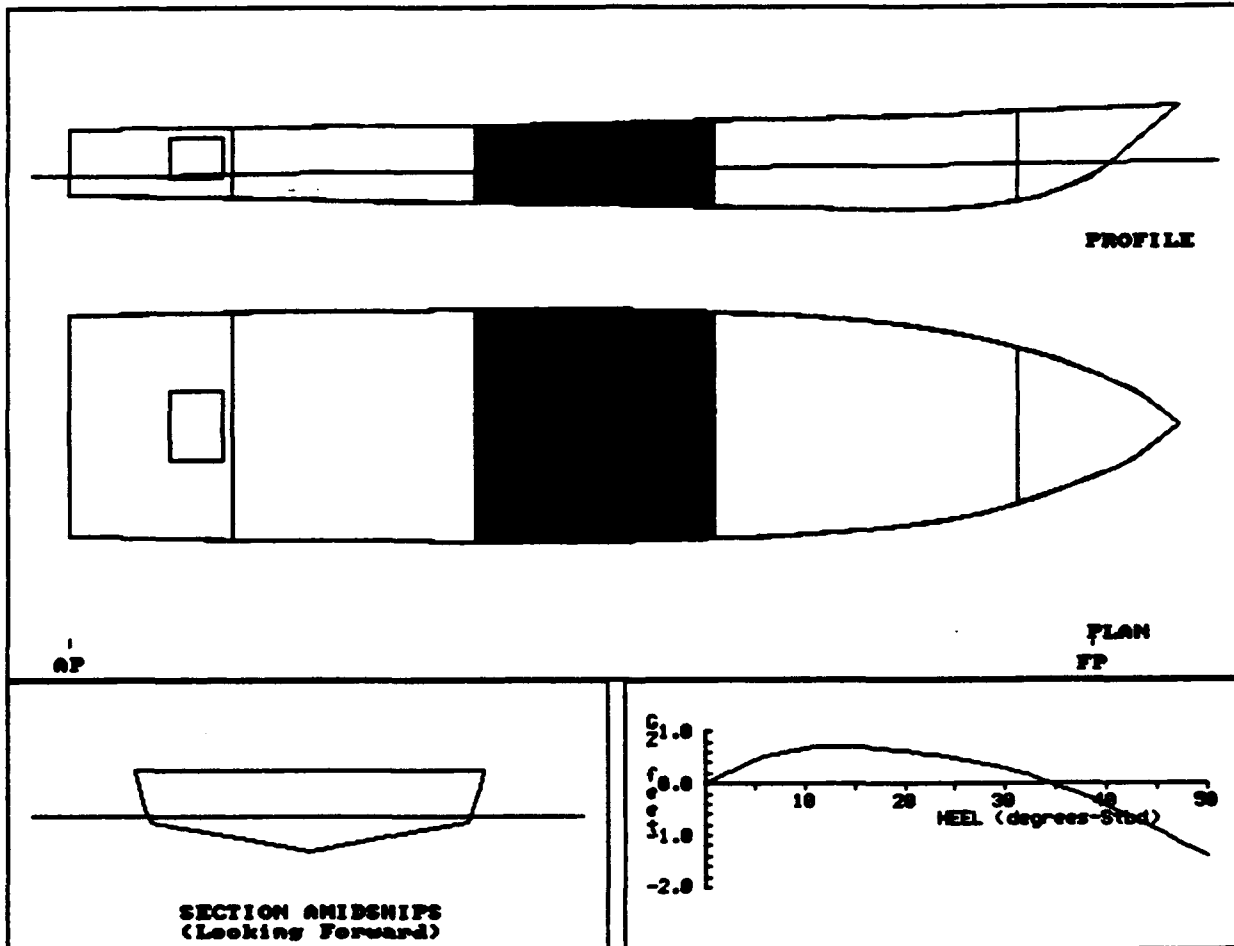

RTRN003A:
 59' FISHING BOAT

COMPARTMENT FLOODING SUMMARY

At 0.0o Heel	PERM.	FLOODED WTR LTons	‡ FULL (Damaged)	‡ FULL (Intact)	SP.VOL. ft3/LT	OUTFLOW LTons
COMPT 3	0.95	8.7	FREE	0.0	----	----
Totals		8.7				

INTACT DATA

Draft at AP = 2.955 ft	Kmt = 20.298 ft	LCG = 32.682A ft-FP
Draft at FP = 3.516 ft	VCG = 10.520 ft	LCB = 32.604A ft-FP
Displacement = 38.0 LTons	Gmt = 9.778 ft	TCG = 0.000 ft-CL

DRAFT/GZ DATA

HEEL degrees	RIGHTING ARM ft	DRAFT AFT ft	DRAFT FWD ft	FLOODED WATER LTons
0.00	0.000	3.062	4.129	8.7
5.00S	0.445	3.058	4.114	8.7
10.00S	0.686	2.956	4.090	8.9
20.00S	0.623	2.431	3.941	9.9
30.00S	0.298	1.559	3.632	11.3
40.00S	-0.426	0.471	3.186	12.1
50.00S	-1.405	-0.969	2.598	12.6

Note: Drafts are measured at A.P. and F.P along ship's centerline

GZ SUMMARY (Evaluated per IMO (SOLAS'90) Rules for Passenger Ships)
 Available Required

Static Heel Angle	0.00 deg	7.00 deg
Angle at Maximum GZ	14.00S deg	
*** Maximum GZ	0.723 ft	1.410 ft
Range of Positive GZ	34.80 deg	15.00 deg
Gmt (upright damaged)	5.118 ft	
Righting Area (0.00-‡.00)	12.208 ft-deg	2.820 ft-deg

*** indicates failure to meet criterion

RTRN004A:
 59' FISHING BOAT

Damaged Compartments:
 COMPT 4 ER

	DISPLACEMENT LTons	DRAFT AFT ft	DRAFT FWD ft	TRIM ft	HEEL deg.	UPRIGHT GMT ft
INTACT	38.0	2.955	3.516	0.561F	0.00	9.778
DAMAGED	51.5	3.974	3.327	0.647A	0.00	5.106

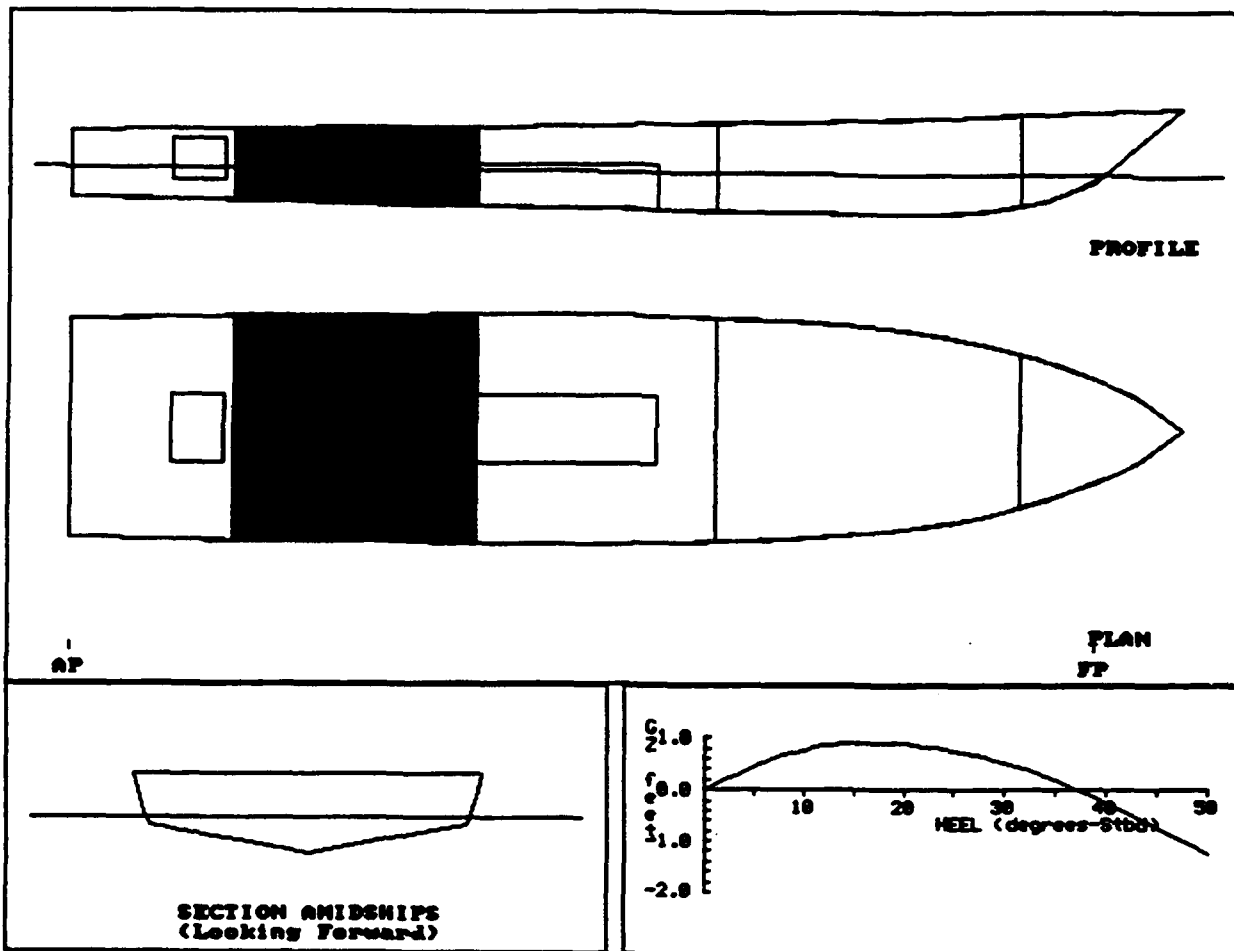

RTRN004A:
 59' FISHING BOAT

COMPARTMENT FLOODING SUMMARY

At 0.0o Heel	PERM.	FLOODED WTR LTons	% FULL (Damaged)	% FULL (Intact)	SP.VOL. ft3/LT	OUTFLOW LTons
COMPT 4 ER	0.85	13.5	FREE	0.0	----	----
Totals		13.5				

INTACT DATA

Draft at AP = 2.955 ft	KMt = 20.298 ft	LCG = 32.682A ft-FP
Draft at FP = 3.516 ft	VCG = 10.520 ft	LCB = 32.604A ft-FP
Displacement = 38.0 LTons	GMT = 9.778 ft	TCG = 0.000 ft-CL

DRAFT/GZ DATA

HEEL degrees	RIGHTING ARM ft	DRAFT AFT ft	DRAFT FWD ft	FLOODED WATER LTons
0.00	0.000	3.974	3.327	13.5
5.00S	0.440	3.978	3.299	13.5
10.00S	0.770	3.956	3.201	13.4
20.00S	0.883	3.615	2.855	13.4
30.00S	0.527	3.002	2.269	13.3
40.00S	-0.250	2.368	1.378	13.2
50.00S	-1.245	1.580	0.195	13.2

Note: Drafts are measured at A.P. and F.P along ship's centerline

GZ SUMMARY (Evaluated per IMO (SOLAS'90) Rules for Passenger Ships)
 Available Required

Static Heel Angle	0.00 deg	7.00 deg
Angle at Maximum GZ	18.00S deg	
*** Maximum GZ	0.911 ft	1.410 ft
Range of Positive GZ	37.21 deg	15.00 deg
Gmt (upright damaged)	5.106 ft	
Righting Area (0.00-1.00)	14.718 ft-deg	2.820 ft-deg

*** indicates failure to meet criterion

RTRN005A:
 59' FISHING BOAT

Imaged Compartments:
 COMPT 5

	DISPLACEMENT LTons	DRAFT AFT ft	DRAFT FWD ft	TRIM ft	HEEL deg.	UPRIGHT GMT ft
INTACT	38.0	2.955	3.516	0.561F	0.00	9.778
DAMAGED	48.1	4.254	2.633	1.622A	0.00	6.008

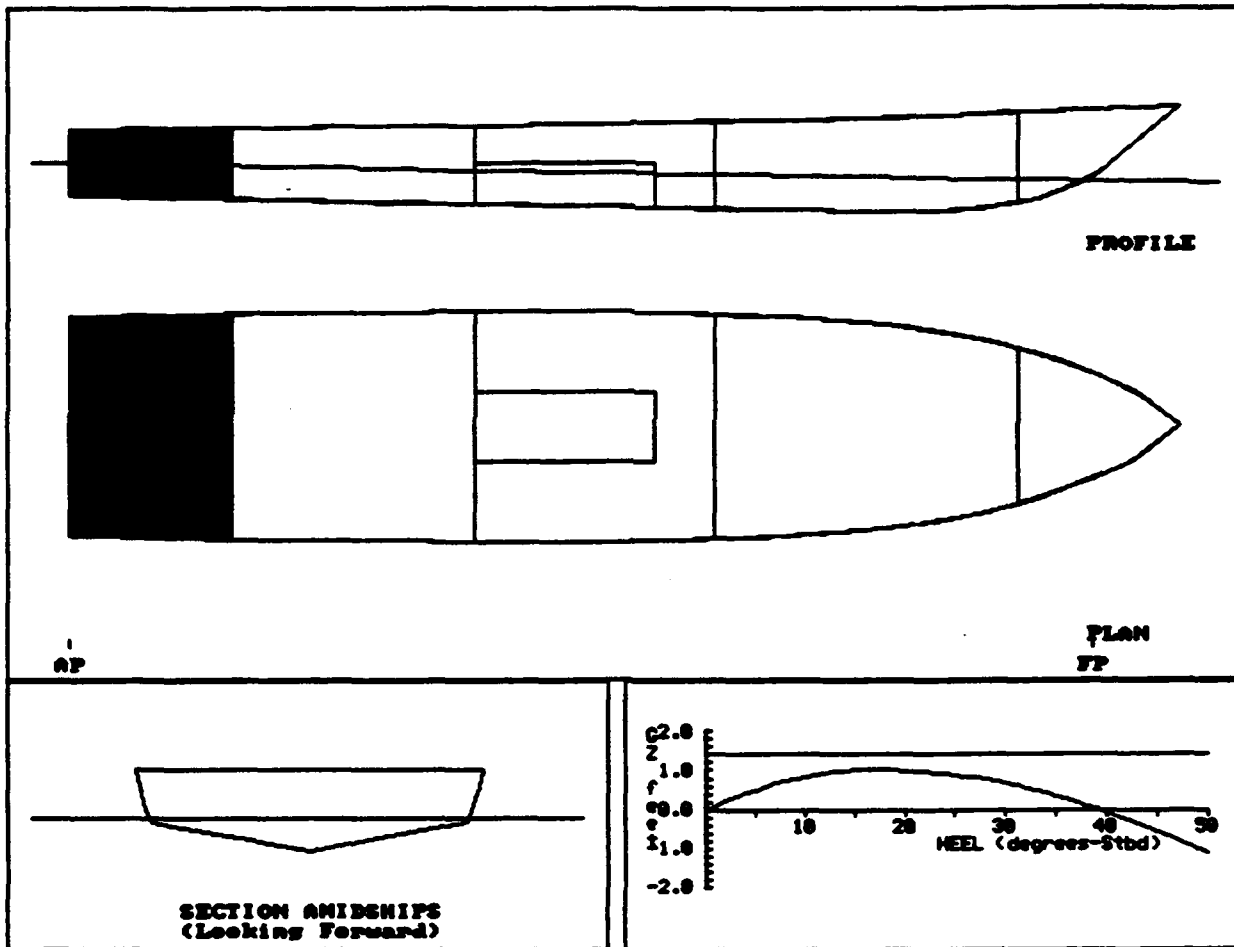

RTRM005A:
 59' FISHING BOAT

COMPARTMENT FLOODING SUMMARY

At 0.0o Heel	PERM.	FLOODED WTR LTons	‡ FULL (Damaged)	‡ FULL (Intact)	SP.VOL. ft3/LT	OUTFLOW LTons
COMPT 5	0.95	10.1	FREE	0.0	----	----
Totals		10.1				

INTACT DATA

Draft at AP = 2.955 ft Kmt = 20.298 ft LCG = 32.682A ft-FP
 Draft at FP = 3.516 ft VCG = 10.520 ft LCB = 32.604A ft-FP
 Displacement = 38.0 LTons Gmt = 9.778 ft TCG = 0.000 ft-CL

DRAFT/GZ DATA

HEEL degrees	RIGHTING ARM ft	DRAFT AFT ft	DRAFT FWD ft	FLOODED WATER LTons
0.00	0.000	4.254	2.633	10.1
5.00S	0.495	4.265	2.584	10.2
10.00S	0.848	4.274	2.427	10.2
20.00S	0.997	3.985	1.985	10.1
30.00S	0.665	3.417	1.304	9.8
40.00S	-0.084	2.868	0.231	9.7
50.00S	-1.098	2.359	-1.447	9.8

Note: Drafts are measured at A.P. and F.P along ship's centerline

GZ SUMMARY (Evaluated per IMO (SOLAS'90) Rules for Passenger Ships)
 Available Required

Static Heel Angle	0.00 deg	7.00 deg
Angle at Maximum GZ	18.00S deg	
*** Maximum GZ	1.015 ft	1.410 ft
Range of Positive GZ	39.07 deg	15.00 deg
Gmt (upright damaged)	6.008 ft	
Righting Area (0.00-‡.00)	16.410 ft-deg	2.820 ft-deg

*** indicates failure to meet criterion

DPTA001A:
 59' FISHING BOAT

Damaged Compartments:
 FOREPEAK

	DISPLACEMENT LTons	DRAFT AFT ft	DRAFT FWD ft	TRIM ft	HEEL deg.	UPRIGHT GMT ft
INTACT	44.0	3.237	3.664	0.427F	0.00	9.844
DAMAGED	44.4	3.193	3.759	0.566F	0.00	9.612

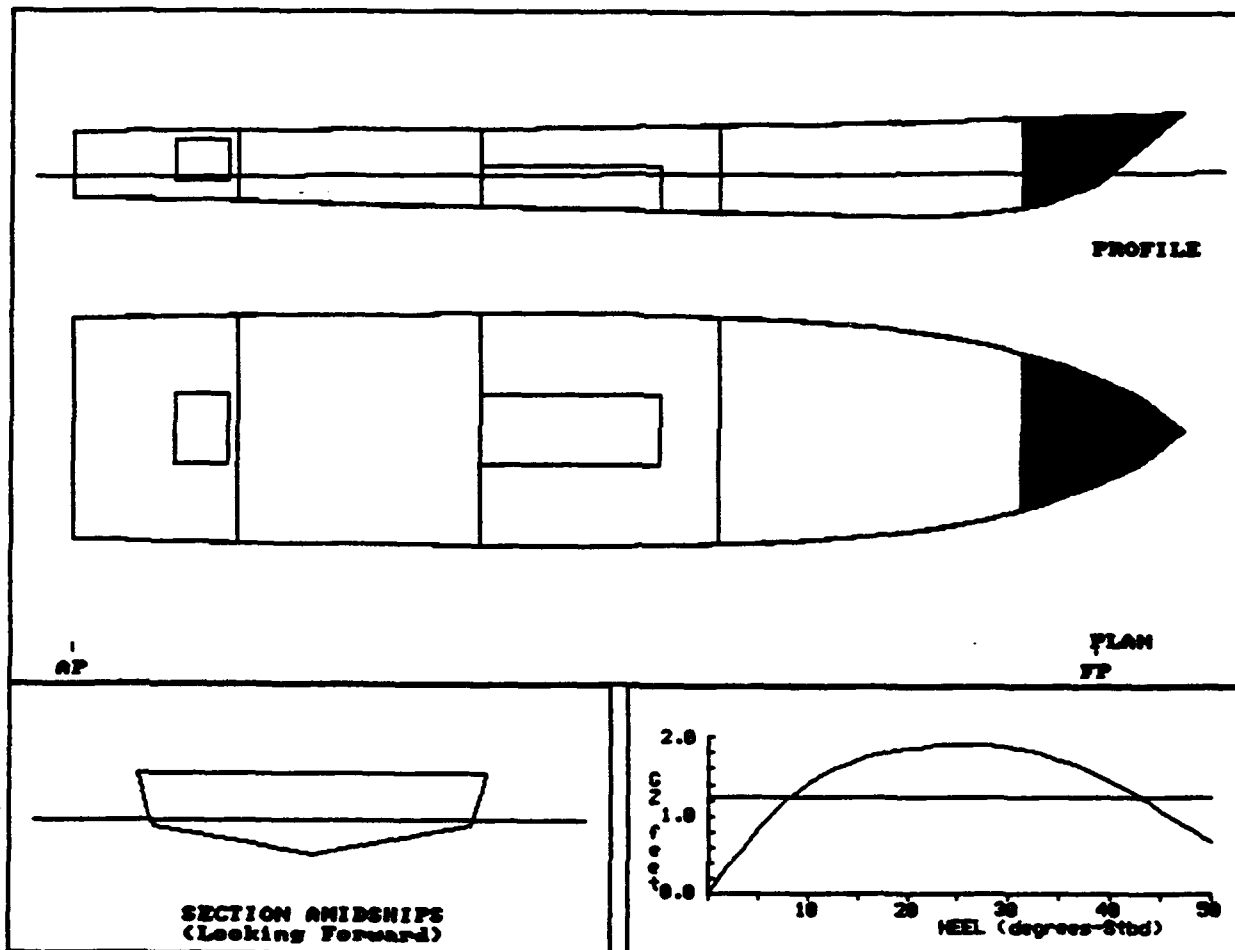

DPTA001A:
 59' FISHING BOAT

COMPARTMENT FLOODING SUMMARY

At 0.0o Heel	PERM.	FLOODED WTR LTons	% FULL (Damaged)	% FULL (Intact)	SP.VOL. ft ³ /LT	OUTFLOW LTons
FOREPEAK	0.95	0.4	FREE	0.0	----	----
Totals		0.4				

INTACT DATA

Draft at AP = 3.237 ft	KMT = 18.244 ft	LCG = 33.139A ft-FP
Draft at FP = 3.664 ft	VCG = 8.400 ft	LCB = 33.096A ft-FP
Displacement = 44.0 LTons	GMT = 9.844 ft	TCG = 0.000 ft-CL

DRAFT/GZ DATA

HEEL degrees	RIGHTING ARM ft	DRAFT AFT ft	DRAFT FWD ft	FLOODED WATER LTons
0.00	0.000	3.193	3.759	0.4
5.00S	0.832	3.197	3.729	0.4
10.00S	1.407	3.104	3.664	0.4
20.00S	1.853	2.571	3.396	0.3
30.00S	1.876	1.654	2.913	0.2
40.00S	1.447	0.488	2.224	0.1
50.00S	0.667	-1.064	1.327	0.1

Note: Drafts are measured at A.P. and F.P along ship's centerline

GZ SUMMARY (Evaluated per IMO (SOLAS'90) Rules for Passenger Ships)

	Available	Required
Static Heel Angle	0.00 deg	7.00 deg
Angle at Maximum GZ	27.00S deg	
Maximum GZ	1.913 ft	1.240 ft
Range of Positive GZ	50.00 deg	15.00 deg
Gmt (upright damaged)	9.612 ft	
Righting Area (0.00-7.00)	28.434 ft-deg	2.820 ft-deg

DPTA002A:
 59' FISHING BOAT

Damaged Compartments:
 COMPT 2

	DISPLACEMENT LTons	DRAFT AFT ft	DRAFT FWD ft	TRIM ft	HEEL deg.	UPRIGHT Gmt ft
INTACT	44.0	3.237	3.664	0.427F	0.00	9.844
DAMAGED	68.7	2.263	6.852	4.589F	0.00	8.199

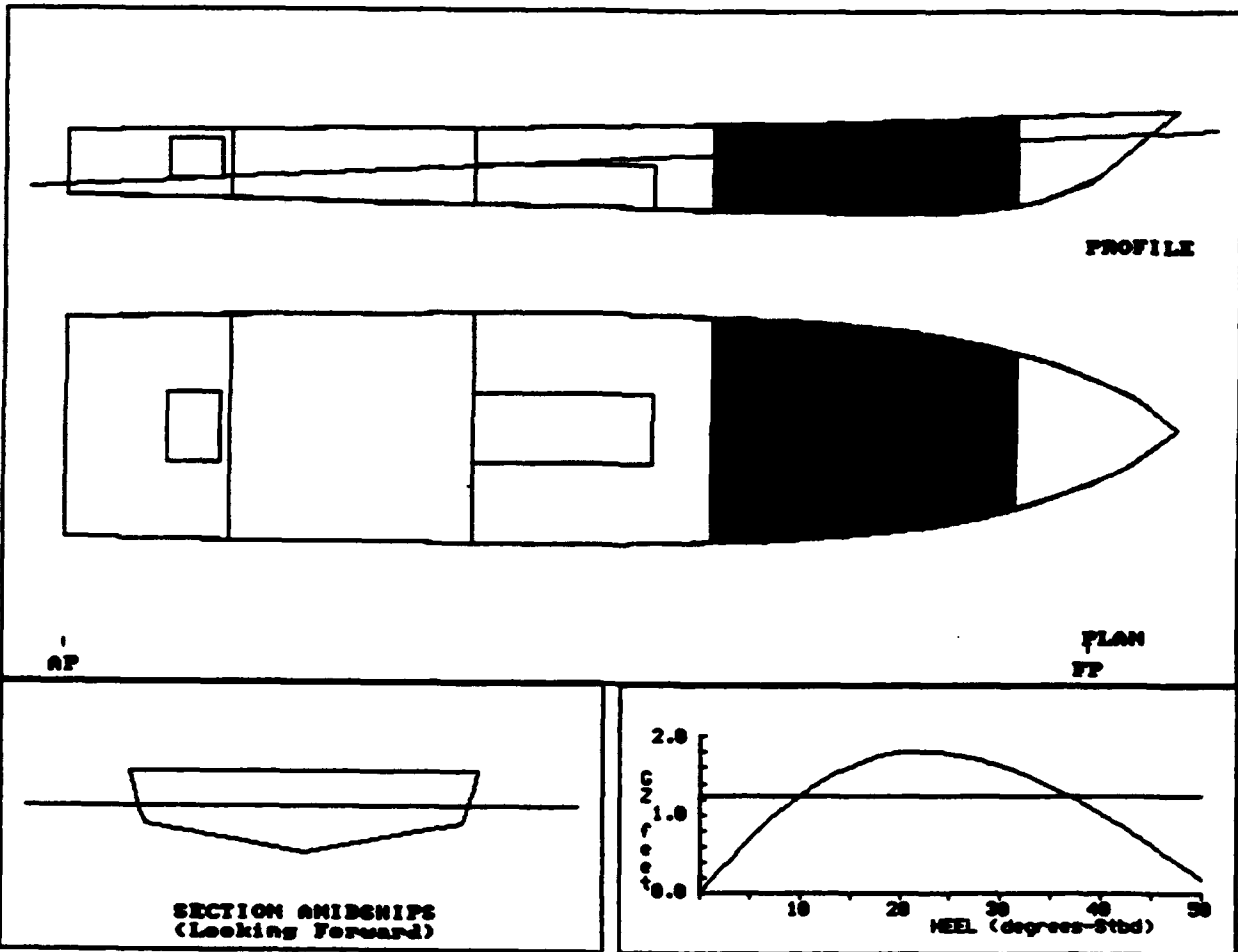

DPTA002A:
 59' FISHING BOAT

COMPARTMENT FLOODING SUMMARY

At 0.0o Heel	PERM.	FLOODED WTR LTons	‡ FULL (Damaged)	‡ FULL (Intact)	SP.VOL. ft3/LT	OUTFLOW LTons
COMPT 2	0.95	24.7	FREE	0.0	----	----
Totals		24.7				

INTACT DATA

Draft at AP = 3.237 ft Kmt = 18.244 ft LCG = 33.139A ft-FP
 Draft at FP = 3.664 ft VCG = 8.400 ft LCB = 33.096A ft-FP
 Displacement = 44.0 LTons Gmt = 9.844 ft TCG = 0.000 ft-CL

DRAFT/GZ DATA

HEEL degrees	RIGHTING ARM ft	DRAFT AFT ft	DRAFT FWD ft	FLOODED WATER LTons
0.00	0.000	2.263	6.852	24.7
5.00S	0.688	2.217	6.874	24.8
10.00S	1.248	2.061	6.935	25.2
20.00S	1.800	1.425	6.990	25.4
30.00S	1.630	0.368	7.180	24.9
40.00S	1.017	-1.106	7.625	24.6
50.00S	0.181	-3.137	8.336	24.3

Note: Drafts are measured at A.P. and F.P along ship's centerline

GZ SUMMARY (Evaluated per IMO (SOLAS'90) Rules for Passenger Ships)
 Available Required

Static Heel Angle	0.00 deg	7.00 deg
Angle at Maximum GZ	23.00S deg	
Maximum GZ	1.817 ft	1.240 ft
Range of Positive GZ	50.00 deg	15.00 deg
Gmt (upright damaged)	8.199 ft	
Righting Area (0.00-‡.00)	26.160 ft-deg	2.820 ft-deg

DPTA003A:
 59' FISHING BOAT

Damaged Compartments:
 COMPT 3

	DISPLACEMENT LTONS	DRAFT AFT ft	DRAFT FWD ft	TRIM ft	HEEL deg.	UPRIGHT GMT ft
INTACT	44.0	3.237	3.664	0.427F	0.00	9.844
DAMAGED	54.2	3.373	4.350	0.976F	0.00	5.856

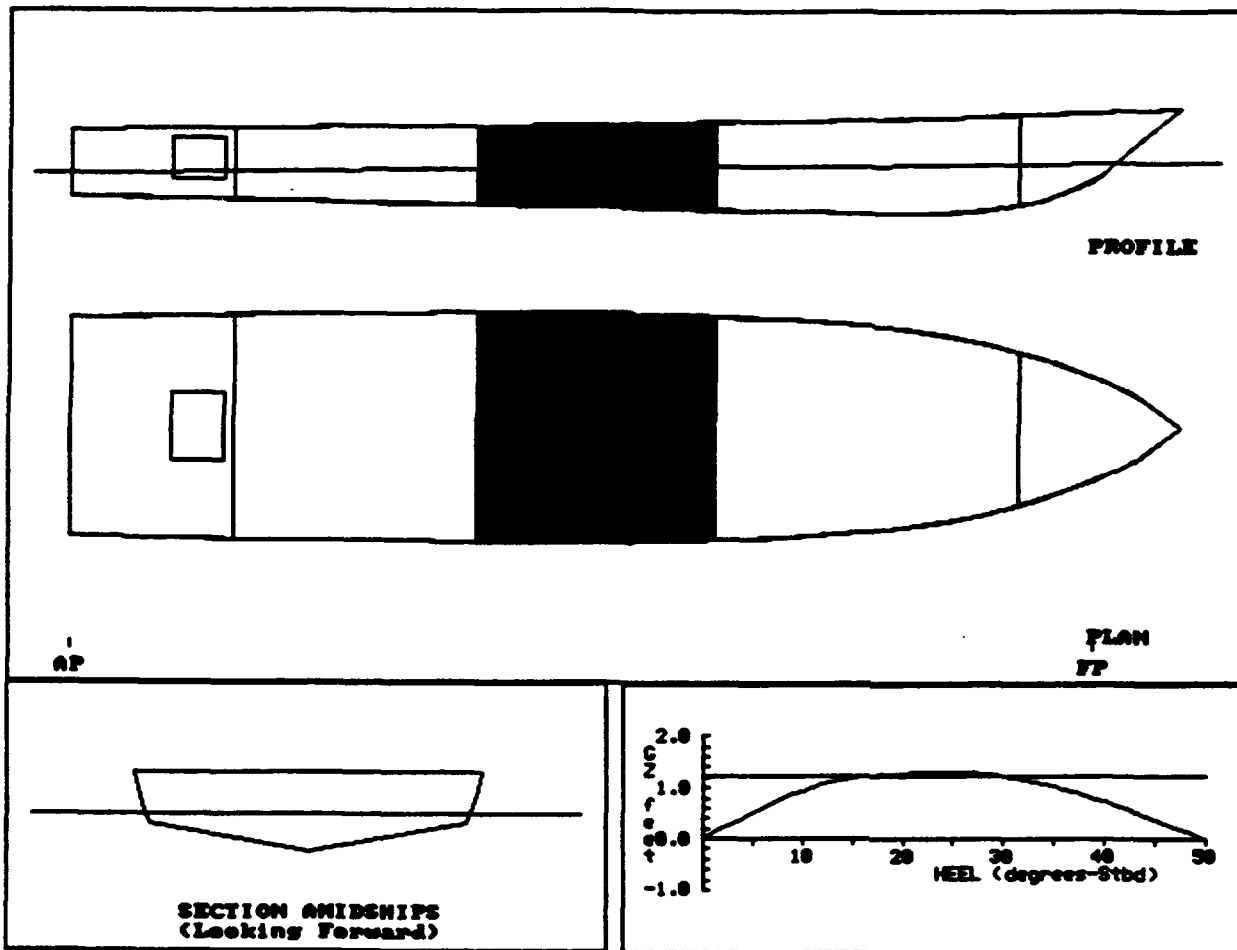

DPTA003A:
 59' FISHING BOAT

COMPARTMENT FLOODING SUMMARY

At 0.0o Heel	PERM.	FLOODED WTR LTons	% FULL (Damaged)	% FULL (Intact)	SP.VOL. ft3/LT	OUTFLOW LTons
COMPT 3	0.95	10.1	FREE	0.0	----	----
Totals		10.1				

INTACT DATA

Draft at AP = 3.237 ft	Kmt = 18.244 ft	LCG = 33.139A ft-FP
Draft at FP = 3.664 ft	VCG = 8.400 ft	LCB = 33.096A ft-FP
Displacement = 44.0 LTons	GMT = 9.844 ft	TCG = 0.000 ft-CL

DRAFT/GZ DATA

HEEL degrees	RIGHTING ARM ft	DRAFT AFT ft	DRAFT FWD ft	FLOODED WATER LTons
0.00	0.000	3.373	4.350	10.1
5.00S	0.514	3.371	4.335	10.2
10.00S	0.951	3.319	4.305	10.3
20.00S	1.279	2.895	4.145	11.2
30.00S	1.237	2.172	3.820	12.4
40.00S	0.729	1.364	3.382	13.1
50.00S	-0.019	0.332	2.808	13.7

Note: Drafts are measured at A.P. and F.P along ship's centerline

GZ SUMMARY (Evaluated per IMO (SOLAS'90) Rules for Passenger Ships)
 Available Required

Static Heel Angle	0.00 deg	7.00 deg
Angle at Maximum GZ	25.00S deg	
Maximum GZ	1.306 ft	1.240 ft
Range of Positive GZ	50.00 deg	15.00 deg
Gmt (upright damaged)	5.856 ft	
Righting Area (0.00- 3 .00)	19.220 ft-deg	2.820 ft-deg

DPTA004A:
 59' FISHING BOAT

Imaged Compartments:
 COMPT 4 ER

	DISPLACEMENT LTons	DRAFT AFT ft	DRAFT FWD ft	TRIM ft	HEEL deg.	UPRIGHT GMT ft
INTACT	44.0	3.237	3.664	0.427F	0.00	9.844
DAMAGED	59.8	4.423	3.447	0.977A	0.00	5.928

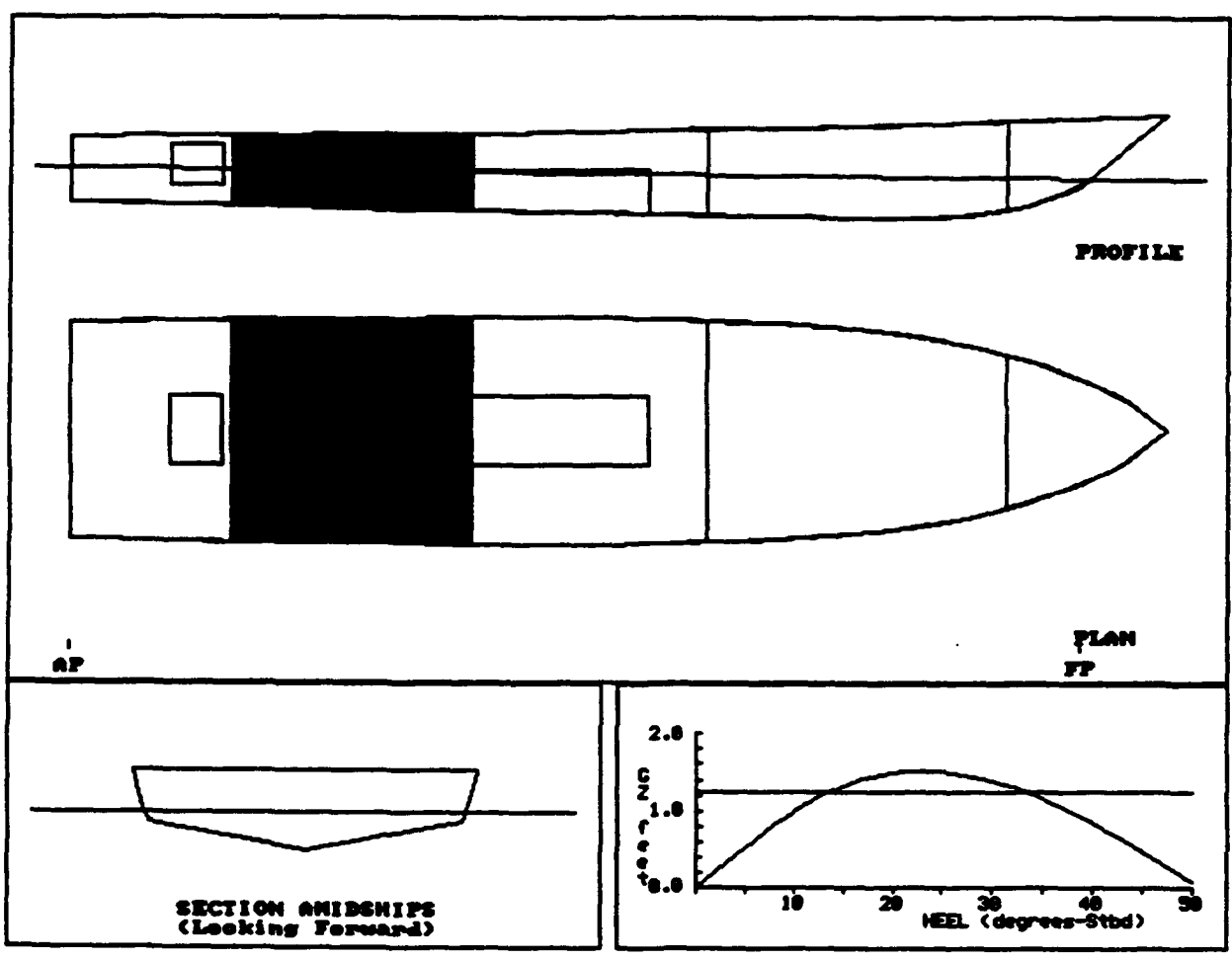

DPTA004A:
 59' FISHING BOAT

COMPARTMENT FLOODING SUMMARY

At 0.0o Heel	PERM.	FLOODED WTR LTons	% FULL (Damaged)	% FULL (Intact)	SP.VOL. ft3/LT	OUTFLOW LTons
COMPT 4 ER	0.85	15.8	FREE	0.0	----	----
Totals		15.8				

INTACT DATA

Draft at AP = 3.237 ft	KMT = 18.244 ft	LCG = 33.139A ft-FP
Draft at FP = 3.664 ft	VCG = 8.400 ft	LCB = 33.096A ft-FP
Displacement = 44.0 LTons	Gmt = 9.844 ft	TCG = 0.000 ft-CL

DRAFT/GZ DATA

HEEL degrees	RIGHTING ARM ft	DRAFT AFT ft	DRAFT FWD ft	FLOODED WATER LTons
0.00	0.000	4.423	3.447	15.8
5.00S	0.516	4.426	3.425	15.8
10.00S	0.985	4.413	3.350	15.7
20.00S	1.489	4.211	2.980	15.7
30.00S	1.383	3.918	2.314	15.7
40.00S	0.839	3.691	1.373	15.6
50.00S	0.078	3.444	0.145	15.6

Note: Drafts are measured at A.P. and F.P along ship's centerline

GZ SUMMARY (Evaluated per IMO (SOLAS'90) Rules for Passenger Ships)
 Available Required

Static Heel Angle	0.00 deg	7.00 deg
Angle at Maximum GZ	24.00S deg	
Maximum GZ	1.516 ft	1.240 ft
Range of Positive GZ	50.00 deg	15.00 deg
Gmt (upright damaged)	5.928 ft	
Righting Area (0.00-3.00)	20.986 ft-deg	2.820 ft-deg

DPTA005A:
 59' FISHING BOAT

Imaged Compartments:
 COMPT 5

	DISPLACEMENT LTons	DRAFT AFT ft	DRAFT FWD ft	TRIM ft	HEEL deg.	UPRIGHT GMT ft
INTACT	44.0	3.237	3.664	0.427F	0.00	9.844
DAMAGED	56.3	4.795	2.619	2.176A	0.00	6.689

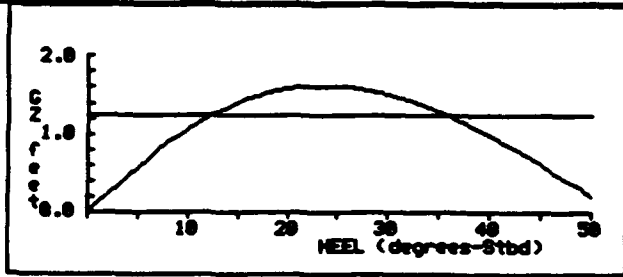
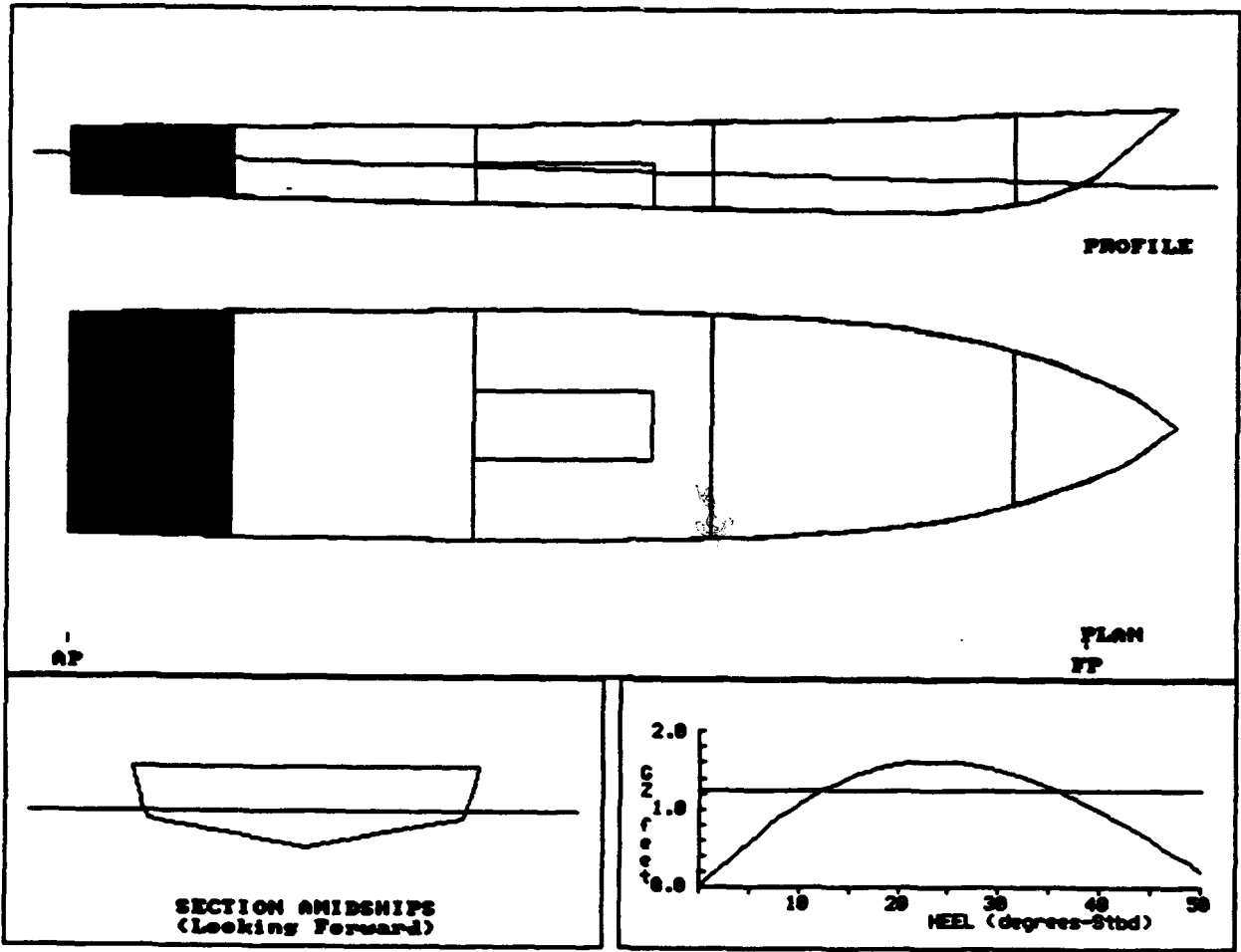

DPTA005A:
 59' FISHING BOAT

COMPARTMENT FLOODING SUMMARY

At 0.0o Heel	PERM.	FLOODED WTR LTons	% FULL (Damaged)	% FULL (Intact)	SP.VOL. ft3/LT	OUTFLOW LTons
COMPT 5	0.95	12.3	FREE	0.0	----	----
Totals		12.3				

INTACT DATA

Draft at AP = 3.237 ft	Kmt = 18.244 ft	LCG = 33.139A ft-FP
Draft at FP = 3.664 ft	VCG = 8.400 ft	LCB = 33.096A ft-FP
Displacement = 44.0 LTons	Gmt = 9.844 ft	TCG = 0.000 ft-CL

DRAFT/GZ DATA

HEEL degrees	RIGHTING ARM ft	DRAFT AFT ft	DRAFT FWD ft	FLOODED WATER LTons
0.00	0.000	4.795	2.619	12.3
5.00S	0.573	4.802	2.585	12.3
10.00S	1.062	4.824	2.446	12.4
20.00S	1.586	4.670	1.973	12.1
30.00S	1.504	4.462	1.155	11.8
40.00S	0.983	4.369	-0.039	11.7
50.00S	0.209	4.435	-1.834	11.8

Note: Drafts are measured at A.P. and F.P along ship's centerline

GZ SUMMARY (Evaluated per IMO (SOLAS'90) Rules for Passenger Ships)
 Available Required

Static Heel Angle	0.00 deg	7.00 deg
Angle at Maximum GZ	24.00S deg	
Maximum GZ	1.619 ft	1.240 ft
Range of Positive GZ	50.00 deg	15.00 deg
Gmt (upright damaged)	6.689 ft	
Righting Area (0.00-5.00)	22.555 ft-deg	2.820 ft-deg

RTNA001A:
 59' FISHING BOAT

Imaged Compartments:
 FOREPEAK

	DISPLACEMENT LTons	DRAFT AFT ft	DRAFT FWD ft	TRIM ft	HEEL deg.	UPRIGHT Gmt ft
INTACT	38.0	2.955	3.516	0.561F	0.00	11.088
DAMAGED	38.4	2.917	3.599	0.682F	0.00	10.800

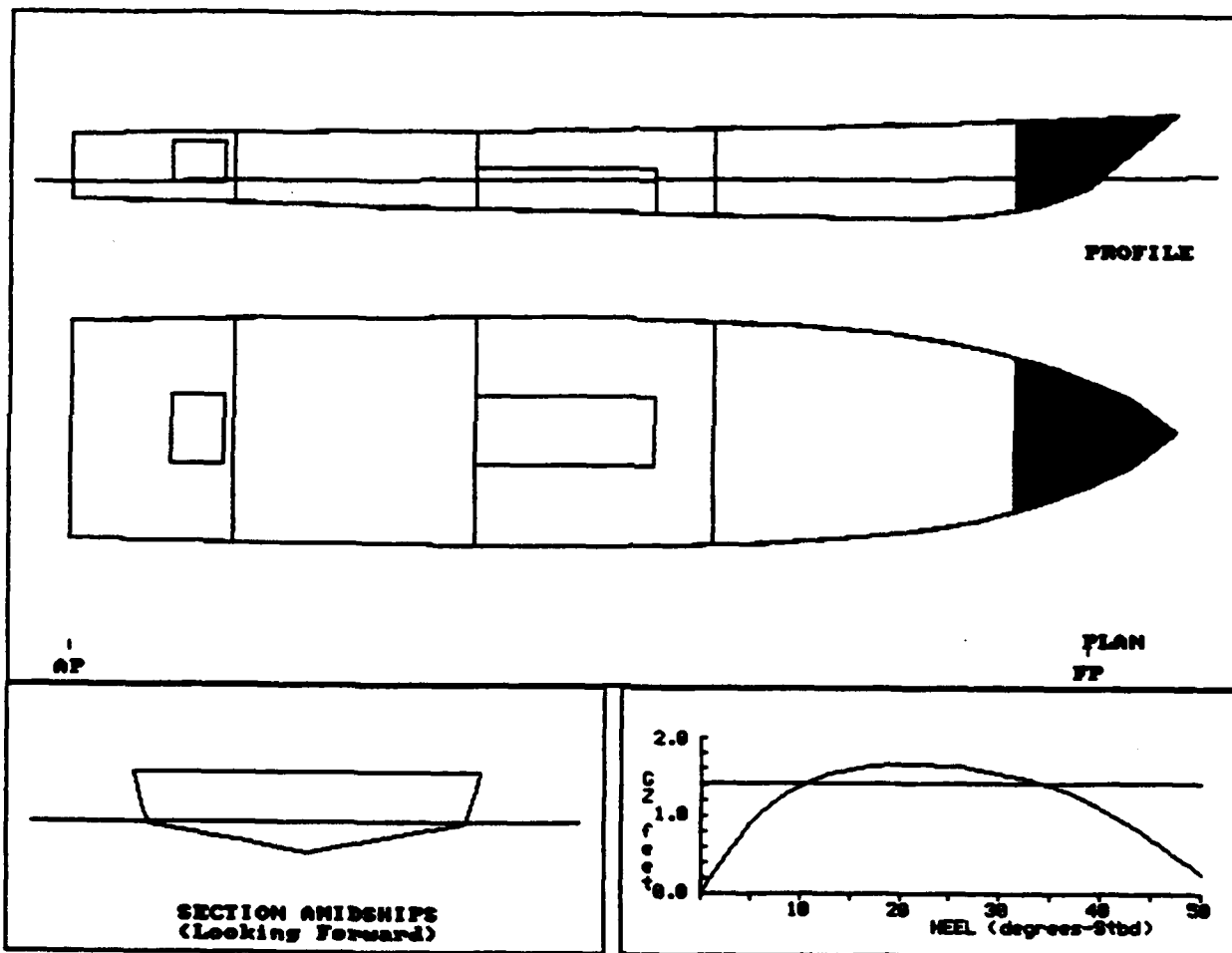

RTNA001A:
 59' FISHING BOAT

COMPARTMENT FLOODING SUMMARY

At 0.0o Heel	PERM.	FLOODED WTR LTons	% FULL (Damaged)	% FULL (Intact)	SP.VOL. ft3/LT	OUTFLOW LTons
FOREPEAK	0.95	0.4	FREE	0.0	----	----
Totals		0.4				

INTACT DATA

Draft at AP = 2.955 ft	Kmt = 20.298 ft	LCG = 32.669A ft-FP
Draft at FP = 3.516 ft	VCG = 9.210 ft	LCB = 32.604A ft-FP
Displacement = 38.0 LTons	Gmt = 11.088 ft	TCG = 0.000 ft-CL

DRAFT/GZ DATA

HEEL degrees	RIGHTING ARM ft	DRAFT AFT ft	DRAFT FWD ft	FLOODED WATER LTons
0.00	0.000	2.917	3.599	0.4
5.00S	0.882	2.911	3.562	0.4
10.00S	1.372	2.765	3.501	0.3
20.00S	1.655	2.132	3.245	0.3
30.00S	1.547	1.101	2.782	0.2
40.00S	1.097	-0.326	2.107	0.1
50.00S	0.249	-2.274	1.213	0.0

Note: Drafts are measured at A.P. and F.P along ship's centerline

GZ SUMMARY (Evaluated per IMO (SOLAS'90) Rules for Passenger Ships)
 Available Required

Static Heel Angle	0.00 deg	7.00 deg
Angle at Maximum GZ	22.00S deg	
Maximum GZ	1.657 ft	1.410 ft
Range of Positive GZ	50.00 deg	15.00 deg
Gmt (upright damaged)	10.800 ft	
Righting Area (0.00-3.00)	27.044 ft-deg	2.820 ft-deg

RTNA002A:
 59' FISHING BOAT

Imaged Compartments:
 COMPT 2

	DISPLACEMENT LTons	DRAFT AFT ft	DRAFT FWD ft	TRIM ft	HEEL deg.	UPRIGHT GMT ft
INTACT	38.0	2.955	3.516	0.561F	0.00	11.088
DAMAGED	60.3	2.031	6.486	4.455F	0.00	8.570

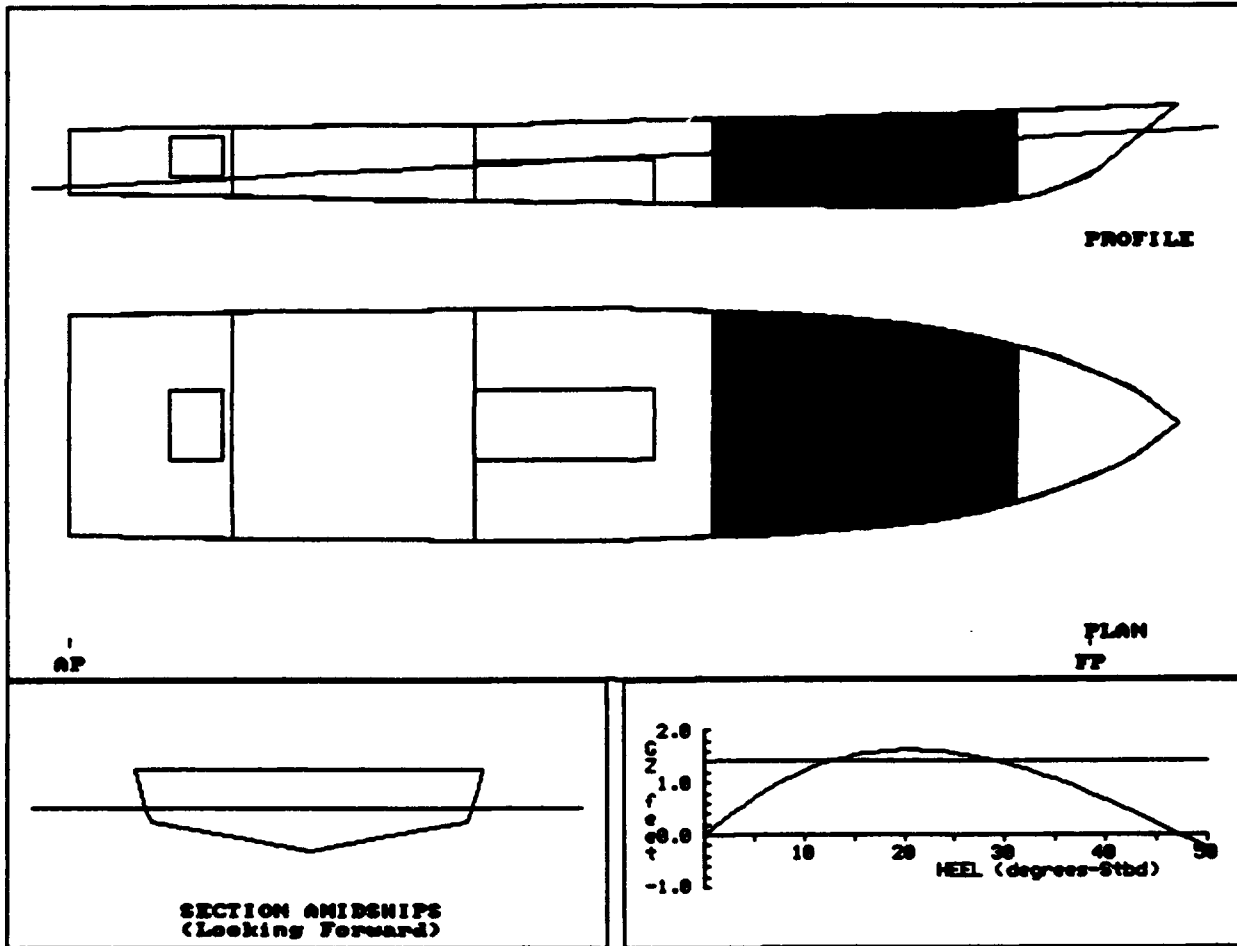

RTNA002A:
 59' FISHING BOAT

COMPARTMENT FLOODING SUMMARY

At 0.0o Heel	PERM.	FLOODED WTR LTons	% FULL (Damaged)	% FULL (Intact)	SP.VOL. ft3/LT	OUTFLOW LTons
COMPT 2	0.95	22.3	FREE	0.0	----	----
Totals		22.3				

INTACT DATA

Draft at AP = 2.955 ft	Kmt = 20.298 ft	LCG = 32.669A ft-FP
Draft at FP = 3.516 ft	VCG = 9.210 ft	LCB = 32.604A ft-FP
Displacement = 38.0 LTons	Gmt = 11.088 ft	TCG = 0.000 ft-CL

DRAFT/GZ DATA

HEEL degrees	RIGHTING ARM ft	DRAFT AFT ft	DRAFT FWD ft	FLOODED WATER LTons
0.00	0.000	2.031	6.486	22.3
5.00S	0.701	1.950	6.550	22.6
10.00S	1.216	1.739	6.642	23.1
20.00S	1.622	1.004	6.688	23.4
30.00S	1.373	-0.162	6.750	22.9
40.00S	0.673	-1.814	7.023	22.5
50.00S	-0.257	-4.158	7.541	22.3

Note: Drafts are measured at A.P. and F.P along ship's centerline

GZ SUMMARY (Evaluated per IMO (SOLAS'90) Rules for Passenger Ships)

	Available	Required
Static Heel Angle	0.00 deg	7.00 deg
Angle at Maximum GZ	22.00S deg	
Maximum GZ	1.623 ft	1.410 ft
Range of Positive GZ	47.31 deg	15.00 deg
Gmt (upright damaged)	8.570 ft	
Righting Area (0.00-%.00)	24.751 ft-deg	2.820 ft-deg

**RTNA003A:
 59' FISHING BOAT**

**Damaged Compartments:
 COMPT 3**

	DISPLACEMENT LTons	DRAFT AFT ft	DRAFT FWD ft	TRIM ft	HEEL deg.	UPRIGHT GWT ft
INTACT	38.0	2.955	3.516	0.561F	0.00	11.088
DAMAGED	46.7	3.065	4.125	1.061F	0.00	6.427

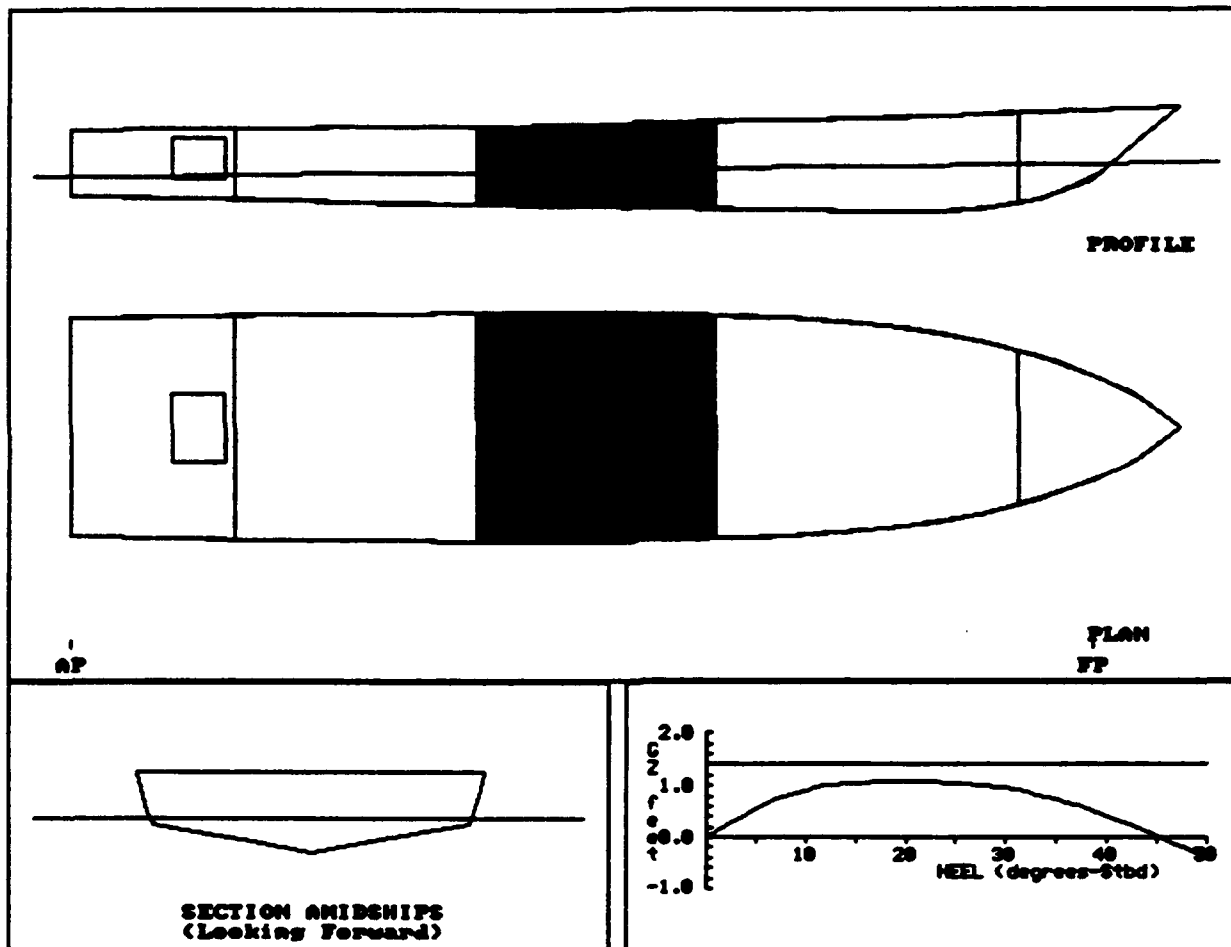

RTMA003A:
 59' FISHING BOAT

COMPARTMENT FLOODING SUMMARY

At 0.0o Heel	PERM.	FLOODED WTR LTons	% FULL (Damaged)	% FULL (Intact)	SP.VOL. ft3/LT	OUTFLOW LTons
COMPT 3	0.95	8.7	FREE	0.0	----	----
Totals		8.7				

INTACT DATA

Draft at AP = 2.955 ft KMt = 20.298 ft LCG = 32.669A ft-FP
 Draft at FP = 3.516 ft VCG = 9.210 ft LCB = 32.604A ft-FP
 Displacement = 38.0 LTons GMT = 11.088 ft TCG = 0.000 ft-CL

DRAFT/GZ DATA

HEEL degrees	RIGHTING ARM ft	DRAFT AFT ft	DRAFT FWD ft	FLOODED WATER LTons
0.00	0.000	3.065	4.125	8.7
5.00S	0.559	3.060	4.111	8.7
10.00S	0.914	2.958	4.087	8.9
20.00S	1.072	2.434	3.938	9.9
30.00S	0.954	1.564	3.627	11.3
40.00S	0.416	0.477	3.179	12.1
50.00S	-0.401	-0.960	2.589	12.6

Note: Drafts are measured at A.P. and F.P along ship's centerline

GZ SUMMARY (Evaluated per IMO (SOLAS'90) Rules for Passenger Ships)
 Available Required

Static Heel Angle	0.00 deg	7.00 deg
Angle at Maximum GZ	20.00S deg	
*** Maximum GZ	1.073 ft	1.410 ft
Range of Positive GZ	45.26 deg	15.00 deg
Gmt (upright damaged)	6.427 ft	
Righting Area (0.00-7.00)	17.678 ft-deg	2.820 ft-deg

*** indicates failure to meet criterion

RTNA004A:
 59' FISHING BOAT

Imaged Compartments:
 COMPT 4 ER

	DISPLACEMENT LTons	DRAFT AFT ft	DRAFT FWD ft	TRIM ft	HEEL deg.	UPRIGHT GMT ft
INTACT	38.0	2.955	3.516	0.561F	0.00	11.088
DAMAGED	51.5	3.969	3.333	0.636A	0.00	6.418

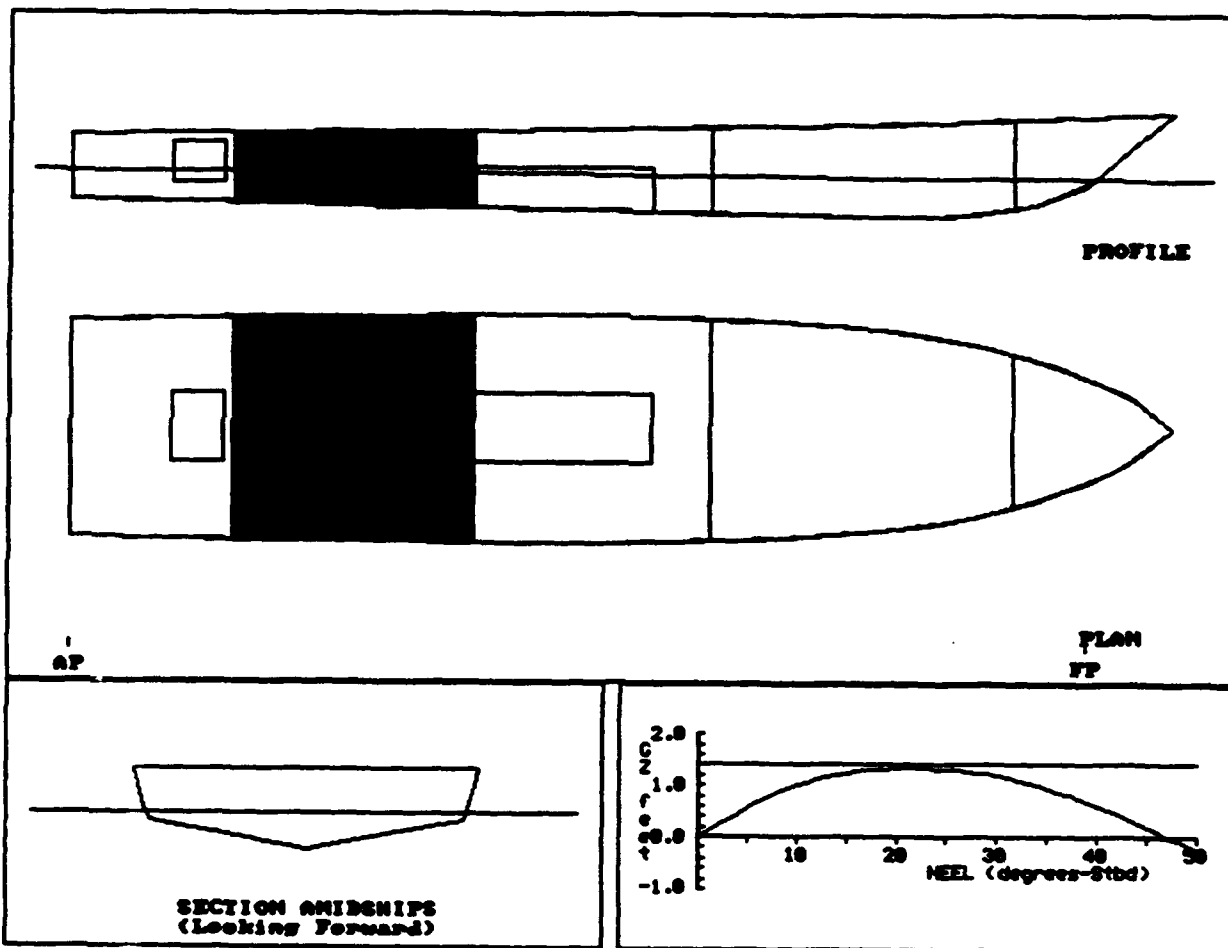

RTNA004A:
 59' FISHING BOAT

COMPARTMENT FLOODING SUMMARY

At 0.0o Heel	PERM.	FLOODED WTR LTons	% FULL (Damaged)	% FULL (Intact)	SP.VOL. ft3/LT	OUTFLOW LTons
COMPT 4 ER	0.85	13.5	FREE	0.0	----	----
Totals		13.5				

INTACT DATA

Draft at AP = 2.955 ft	Kmt = 20.298 ft	LCG = 32.669A ft-FP
Draft at FP = 3.516 ft	VCG = 9.210 ft	LCB = 32.604A ft-FP
Displacement = 38.0 LTons	Gmt = 11.088 ft	TCG = 0.000 ft-CL

DRAFT/GZ DATA

HEEL degrees	RIGHTING ARM ft	DRAFT AFT ft	DRAFT FWD ft	FLOODED WATER LTons
0.00	0.000	3.969	3.333	13.5
5.00S	0.555	3.972	3.305	13.5
10.00S	0.998	3.949	3.209	13.4
20.00S	1.330	3.607	2.863	13.3
30.00S	1.182	2.992	2.278	13.3
40.00S	0.593	2.354	1.390	13.2
50.00S	-0.241	1.561	0.210	13.2

Note: Drafts are measured at A.P. and F.P along ship's centerline

GZ SUMMARY (Evaluated per IMO (SOLAS'90) Rules for Passenger Ships)
 Available Required

Static Heel Angle	0.00 deg	7.00 deg
Angle at Maximum GZ	23.00S deg	
*** Maximum GZ	1.335 ft	1.410 ft
Range of Positive GZ	47.20 deg	15.00 deg
Gmt (upright damaged)	6.418 ft	
Righting Area (0.00-7.00)	20.185 ft-deg	2.820 ft-deg

*** indicates failure to meet criterion

**RTNA005A:
 59' FISHING BOAT**

Damaged Compartments:
 COMPT 5

	DISPLACEMENT LTons	DRAFT AFT ft	DRAFT FWD ft	TRIM ft	HEEL deg.	UPRIGHT GMT ft
INTACT	38.0	2.955	3.516	0.561F	0.00	11.088
DAMAGED	48.1	4.239	2.649	1.589A	0.00	7.327

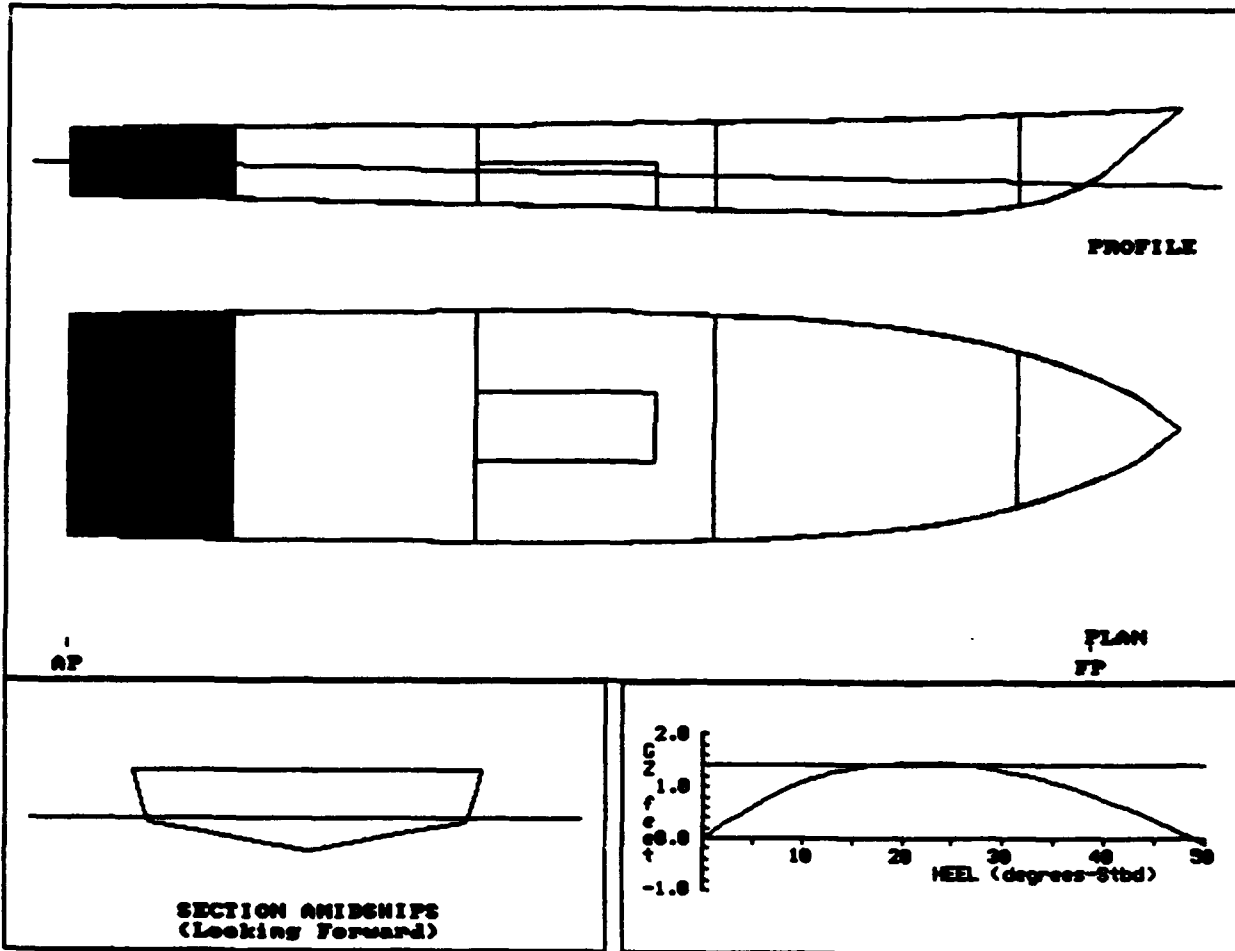

RTMA005A:
 59' FISHING BOAT

COMPARTMENT FLOODING SUMMARY

At 0.0o Heel	PERM.	FLOODED WTR LTons	% FULL (Damaged)	% FULL (Intact)	SP.VOL. ft ³ /LT	OUTFLOW LTons
COMPT 5	0.95	10.1	FREE	0.0	----	----
Totals		10.1				

INTACT DATA

Draft at AP = 2.955 ft	Kmt = 20.298 ft	LCG = 32.669A ft-FP
Draft at FP = 3.516 ft	VCG = 9.210 ft	LCB = 32.604A ft-FP
Displacement = 38.0 LTons	Gmt = 11.088 ft	TCG = 0.000 ft-CL

DRAFT/GZ DATA

HEEL degrees	RIGHTING ARM ft	DRAFT AFT ft	DRAFT FWD ft	FLOODED WATER LTons
0.00	0.000	4.239	2.649	10.1
5.00S	0.610	4.248	2.602	10.1
10.00S	1.076	4.254	2.448	10.2
20.00S	1.445	3.962	2.010	10.1
30.00S	1.321	3.389	1.331	9.8
40.00S	0.759	2.830	0.266	9.7
50.00S	-0.092	2.305	-1.397	9.8

Note: Drafts are measured at A.P. and F.P along ship's centerline

GZ SUMMARY (Evaluated per IMO (SOLAS'90) Rules for Passenger Ships)
 Available Required

Static Heel Angle	0.00 deg	7.00 deg
Angle at Maximum GZ	23.00S deg	
Maximum GZ	1.454 ft	1.410 ft
Range of Positive GZ	48.96 deg	15.00 deg
Gmt (upright damaged)	7.327 ft	
Righting Area (0.00- 7.00)	21.886 ft-deg	2.820 ft-deg

**APPENDIX B
HYDROSTATICS AND
DAMAGE STABILITY
OUTPUT**

80' SHUTTLE BOAT

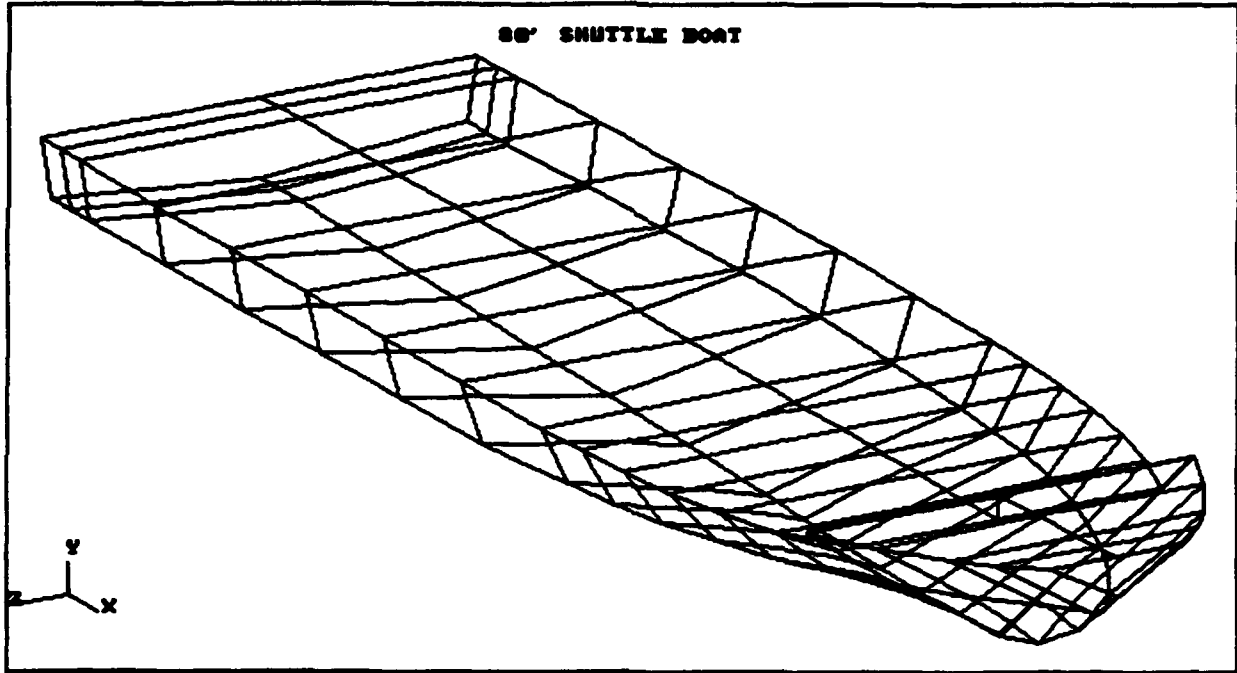

DAMAGE STABILITY SUMMARY
 80'ER

DEPART

CASE	VLE NAME	DAMAGED	COMP. LISTING	---Intact Condition---			-----Equilibrium Condition After Damage-----					
				MIN.DRAFT (ft)	VCG (ft)	GMT (ft)	HEEL (deg)	MAX.GZ (ft)	RANGE (deg)	AREA (ft-deg)	DAM.GMT (ft)	SURVIVAL
	RT001A	1		4.887	10.900	8.560	0.0	1.800	40.00	26.56	8.435	Yes
2	DPRT002A	2		4.887	10.900	8.560	0.0	1.756	40.00	26.13	7.948	Yes
3	DPRT003A	3		4.887	10.900	8.560	0.0	1.542	40.00	22.40	6.352	Yes
4	DPRT004A	4		4.887	10.900	8.560	0.0	1.249	40.00	18.45	5.453	Yes
5	DPRT005A	6		4.887	10.900	8.560	0.2s	1.240	39.84	18.18	----	Yes
6	DPRT006A	7		4.887	10.900	8.560	0.2p	1.371	39.79	19.92	----	Yes
7	DPRT007A	7,8		4.887	10.900	8.560	0.8s	1.353	39.20	19.05	----	Yes
8	DPRT008A	4,5		4.887	10.900	8.560	0.0	1.321	38.73	19.89	5.997	Yes

DAMAGE STABILITY SUMMARY
 80' ER

RETURN

FILE NAME	DAMAGED COMP. LISTING	---Intact Condition---			-----Equilibrium Condition After Damage-----					
		MIN.DRAFT (ft)	VCG (ft)	GMT (ft)	HEEL (deg)	MAX.GZ (ft)	RANGE (deg)	AREA (ft-deg)	DAM.GMT (ft)	SURVIVAL
1 RTRN001B	1	4.701	11.400	8.873	0.0	1.670	40.00	25.70	8.751	Yes
2 RTRN002B	2	4.701	11.400	8.873	0.0	1.686	40.00	25.75	8.278	Yes
3 RTRN003B	3	4.701	11.400	8.873	0.0	1.449	40.00	21.74	6.535	Yes
4 RTRN004B	4	4.701	11.400	8.873	0.0	1.139	38.53	17.50	5.565	Yes
5 RTRN005B	6	4.701	11.400	8.873	0.1S	1.173	37.60	17.52	----	Yes
6 RTRN006B	7	4.701	11.400	8.873	0.2P	1.307	39.80	19.33	----	Yes
7 RTRN007B	7,8	4.701	11.400	8.873	0.2P	1.221	38.46	18.32	----	Yes
8 RTRN008B	4,5	4.701	11.400	8.873	0.0	1.370	40.00	20.31	5.959	Yes

DPR001A:
 80' SHUTTLE BOAT

Imaged Compartments:
 FOREPEAK

	DISPLACEMENT LTons	DRAFT AFT ft	DRAFT FWD ft	TRIM ft	HEEL deg.	UPRIGHT Gmt ft
INTACT	89.4	5.120	4.650	0.470A	0.00	8.571
DAMAGED	91.1	5.013	4.893	0.120A	0.00	8.445

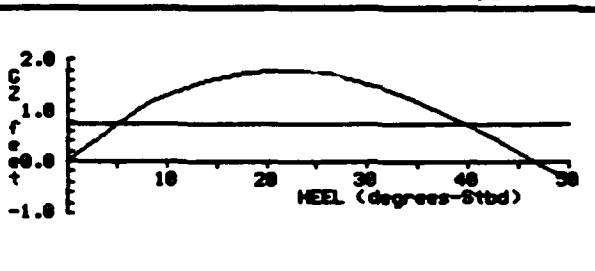
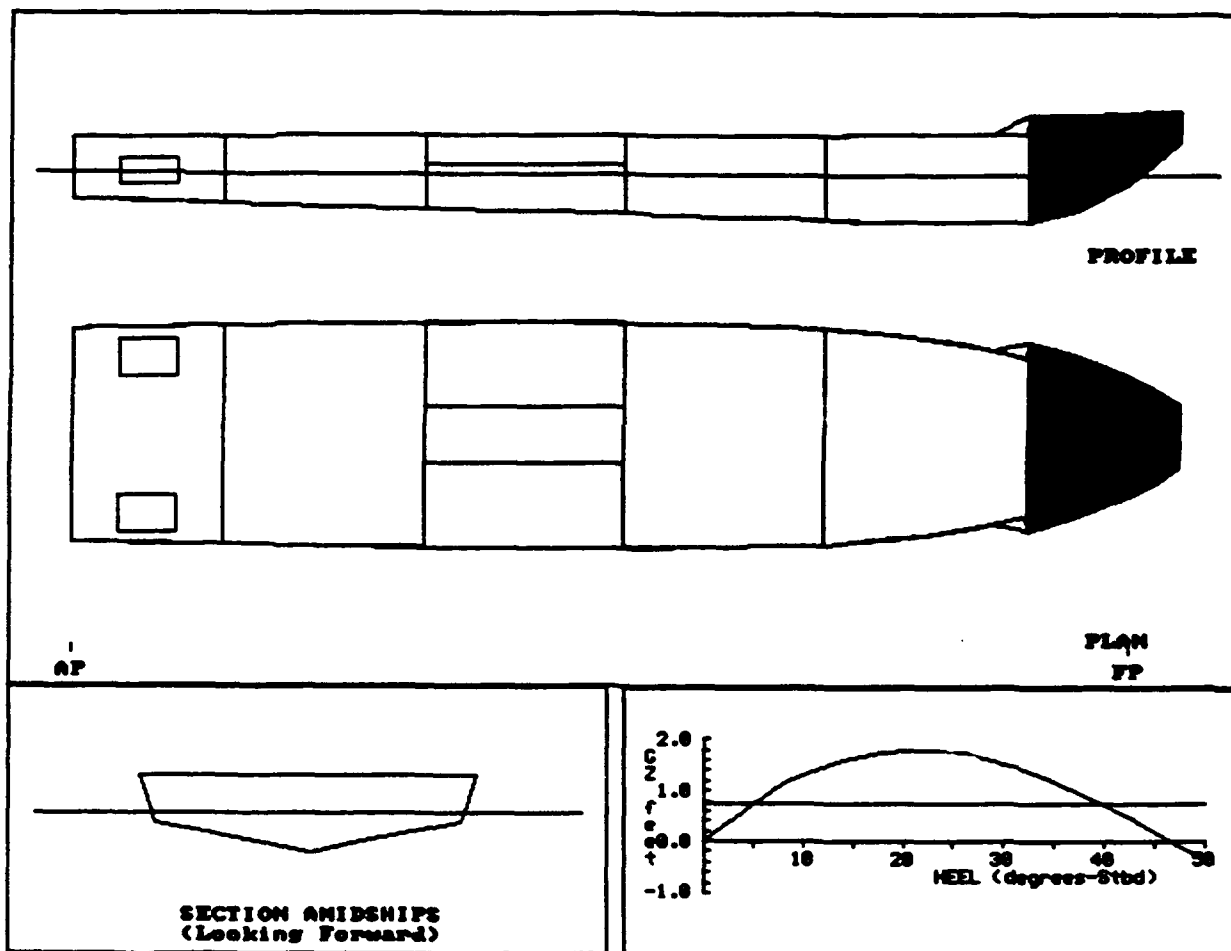

**DPRT001A:
 80' SHUTTLE BOAT**

COMPARTMENT FLOODING SUMMARY

At 0.0o Heel	PERM.	FLOODED WTR LTons	% FULL (Damaged)	% FULL (Intact)	SP.VOL. ft3/LT	OUTFLOW LTons
FOREPEAK	0.95	1.8	FREE	0.0	----	----
Totals		1.8				

INTACT DATA

Draft at AP = 5.120 ft	Kmt = 19.471 ft	LCG = 41.705A ft-FP
Draft at FP = 4.650 ft	VCG = 10.900 ft	LCB = 41.752A ft-FP
Displacement = 89.4 LTons	Gmt = 8.571 ft	TCG = 0.000 ft-CL

DRAFT/GZ DATA

HEEL degrees	RIGHTING ARM ft	DRAFT AFT ft	DRAFT FWD ft	FLOODED WATER LTons
0.00	0.000	5.013	4.893	1.8
5.00S	0.735	5.020	4.855	1.7
10.00S	1.308	4.974	4.746	1.7
20.00S	1.772	4.507	4.342	1.4
25.00S	1.769	4.147	4.039	1.3
30.00S	1.545	3.801	3.693	1.1
40.00S	0.720	3.026	2.972	1.0
50.00S	-0.358	2.006	2.151	1.4

Note: Drafts are measured at A.P. and F.P along ship's centerline

GZ SUMMARY (Evaluated per IMO (SOLAS'90) Rules for Passenger Ships)

	Available	Required
Static Heel Angle	0.00 deg	7.00 deg
Angle at Maximum GZ	24.00S deg	
Maximum GZ	1.793 ft	0.740 ft
Range of Positive GZ	46.76 deg	15.00 deg
Gmt (upright damaged)	8.445 ft	
Righting Area (0.00-7.00)	26.643 ft-deg	2.820 ft-deg

DPR002A:
 80' SHUTTLE BOAT

Damaged Compartments:
 VOID1

	DISPLACEMENT LTons	DRAFT AFT ft	DRAFT FWD ft	TRIM ft	HEEL deg.	UPRIGHT GMT ft
INTACT	89.4	5.120	4.650	0.470A	0.00	8.571
DAMAGED	110.1	4.406	6.708	2.301F	0.00	7.957

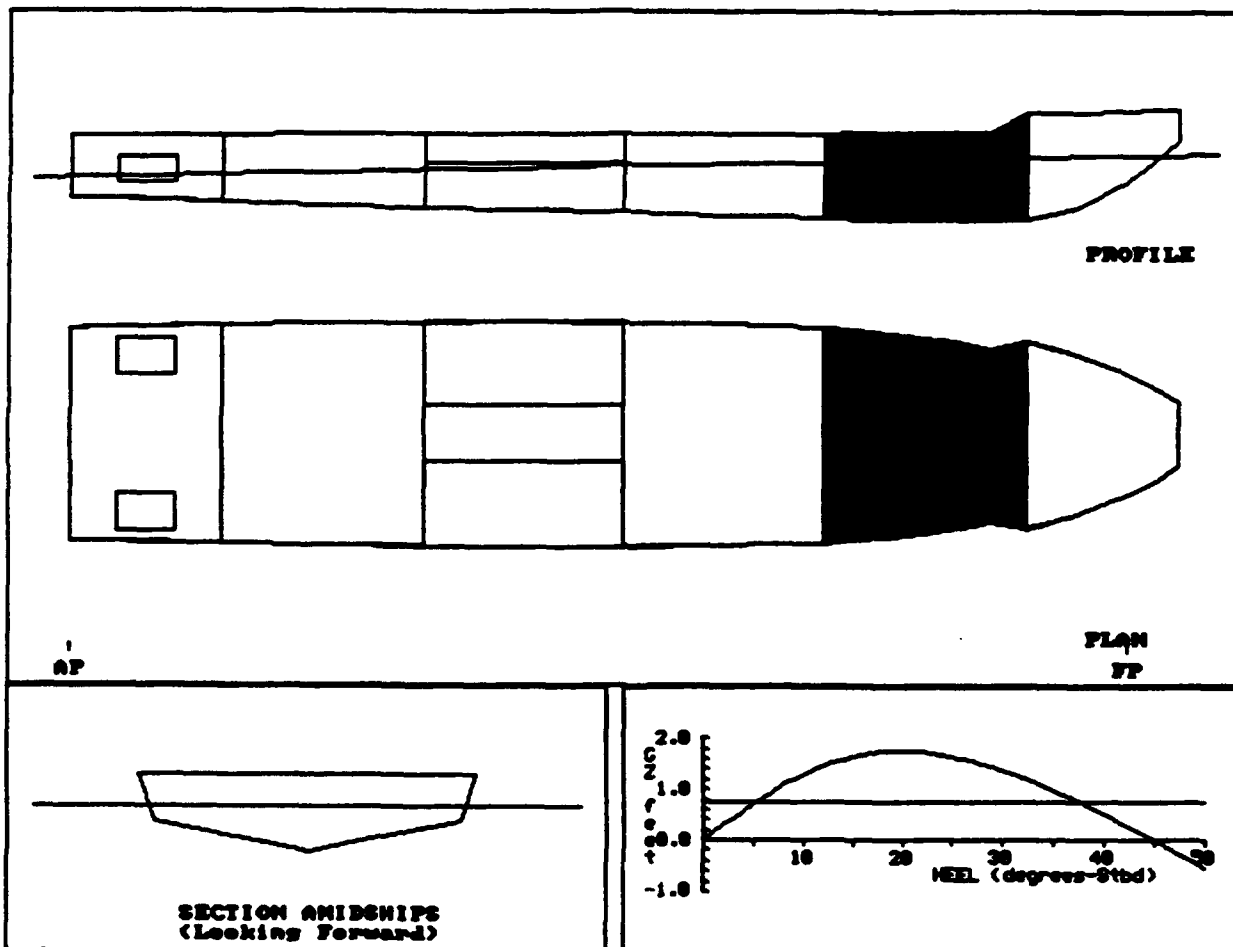

DPRT002A:
 80' SHUTTLE BOAT

COMPARTMENT FLOODING SUMMARY

At 0.0o Heel	PERM.	FLOODED WTR LTons	% FULL (Damaged)	% FULL (Intact)	SP.VOL. ft3/LT	OUTFLOW LTons
VOID1	0.95	20.8	FREE	0.0	----	----
Totals		20.8				

INTACT DATA

Draft at AP = 5.120 ft	Kmt = 19.471 ft	LCG = 41.705A ft-FP
Draft at FP = 4.650 ft	VCG = 10.900 ft	LCB = 41.752A ft-FP
Displacement = 89.4 LTons	Gmt = 8.571 ft	TCG = 0.000 ft-CL

DRAFT/GZ DATA

HEEL degrees	RIGHTING ARM ft	DRAFT AFT ft	DRAFT FWD ft	FLOODED WATER LTons
0.00	0.000	4.406	6.708	20.8
5.00S	0.697	4.410	6.680	20.8
10.00S	1.279	4.314	6.675	21.0
20.00S	1.757	3.724	6.565	21.5
25.00S	1.655	3.292	6.539	21.6
30.00S	1.376	2.843	6.499	21.5
40.00S	0.514	1.897	6.348	21.0
50.00S	-0.549	0.696	6.172	20.5

Note: Drafts are measured at A.P. and F.P along ship's centerline

GZ SUMMARY (Evaluated per IMO (SOLAS'90) Rules for Passenger Ships)
 Available Required

Static Heel Angle	0.00 deg	7.00 deg
Angle at Maximum GZ	21.00S deg	
Maximum GZ	1.757 ft	0.740 ft
Range of Positive GZ	44.93 deg	15.00 deg
Gmt (upright damaged)	7.957 ft	
Righting Area (0.00- 7.00)	26.229 ft-deg	2.820 ft-deg

DPR003A:
 80' SHUTTLE BOAT

Imaged Compartments:
 VOID2

	DISPLACEMENT LTons	DRAFT AFT ft	DRAFT FWD ft	TRIM ft	HEEL deg.	UPRIGHT GMT ft
INTACT	89.4	5.120	4.650	0.470A	0.00	8.571
DAMAGED	114.8	5.004	6.228	1.224F	0.00	6.360

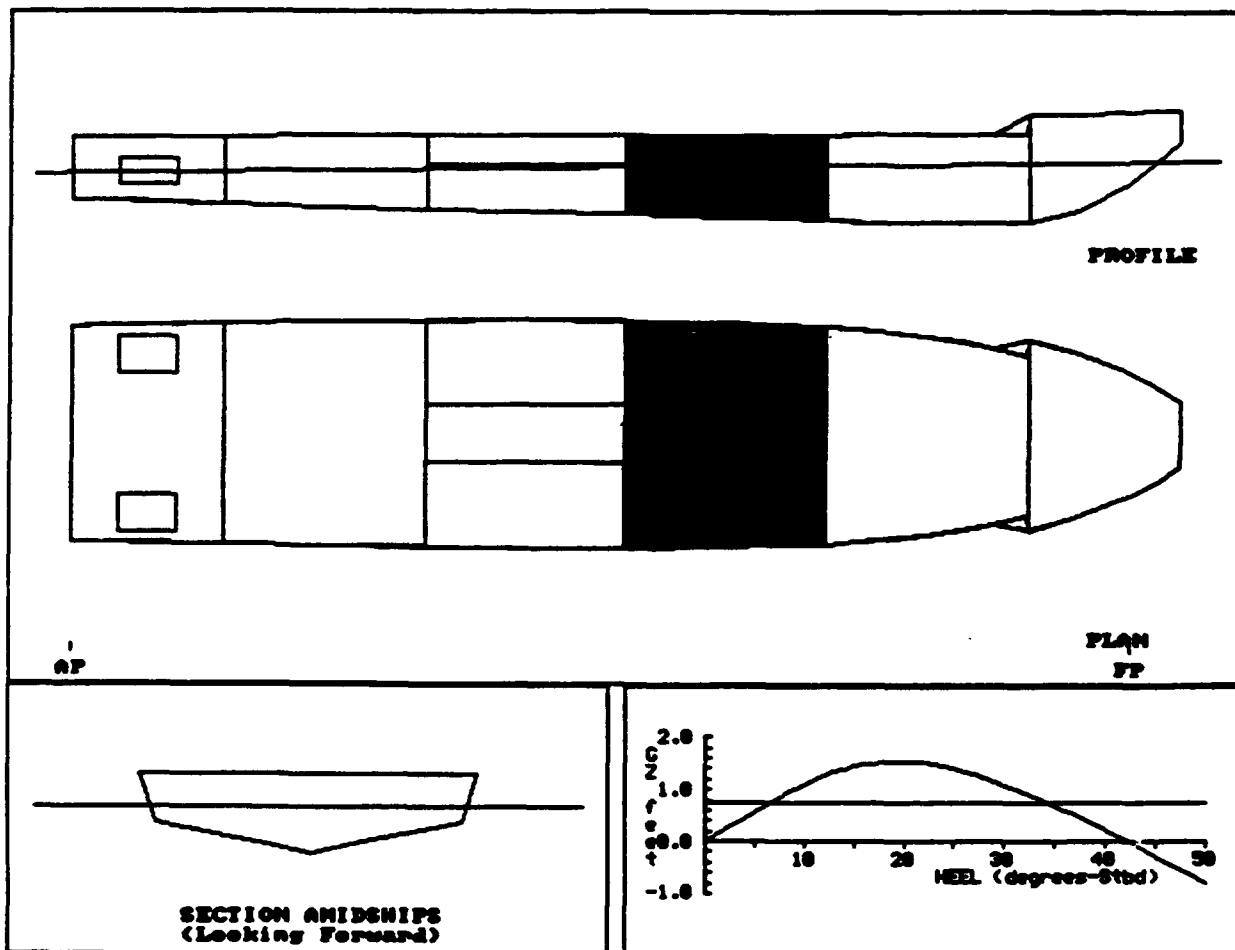

DPRT003A:
 80' SHUTTLE BOAT

COMPARTMENT FLOODING SUMMARY

At 0.0o Heel	PERM.	FLOODED WTR LTons	% FULL (Damaged)	% FULL (Intact)	SP.VOL. ft3/LT	OUTFLOW LTons
VOID2	0.95	25.4	FREE	0.0	----	----
Totals		25.4				

INTACT DATA

Draft at AP = 5.120 ft	Kmt = 19.471 ft	LCG = 41.705A ft-FP
Draft at FP = 4.650 ft	VCG = 10.900 ft	LCB = 41.752A ft-FP
Displacement = 89.4 LTons	GMT = 8.571 ft	TCG = 0.000 ft-CL

DRAFT/GZ DATA

HEEL degrees	RIGHTING ARM ft	DRAFT AFT ft	DRAFT FWD ft	FLOODED WATER LTons
0.00	0.000	5.004	6.228	25.4
5.00S	0.559	5.006	6.200	25.4
10.00S	1.090	4.980	6.136	25.3
20.00S	1.542	4.549	5.891	25.3
25.00S	1.408	4.257	5.754	25.1
30.00S	1.094	3.976	5.611	24.8
40.00S	0.223	3.415	5.226	24.2
50.00S	-0.813	2.729	4.752	23.7

Note: Drafts are measured at A.P. and F.P along ship's centerline

GZ SUMMARY (Evaluated per IMO (SOLAS'90) Rules for Passenger Ships)
 Available Required

Static Heel Angle	0.00 deg	7.00 deg
Angle at Maximum GZ	21.00S deg	
Maximum GZ	1.542 ft	0.740 ft
Range of Positive GZ	42.23 deg	15.00 deg
Gmt (upright damaged)	6.360 ft	
Righting Area (0.00-3.00)	22.570 ft-deg	2.820 ft-deg

DPR004A:
 80' SHUTTLE BOAT

Imaged Compartments:
 A/C ETC

	DISPLACEMENT LTons	DRAFT AFT ft	DRAFT FWD ft	TRIM ft	HEEL deg.	UPRIGHT GMT ft
INTACT	89.4	5.120	4.650	0.470A	0.00	8.571
DAMAGED	102.1	5.450	4.957	0.493A	0.00	5.460

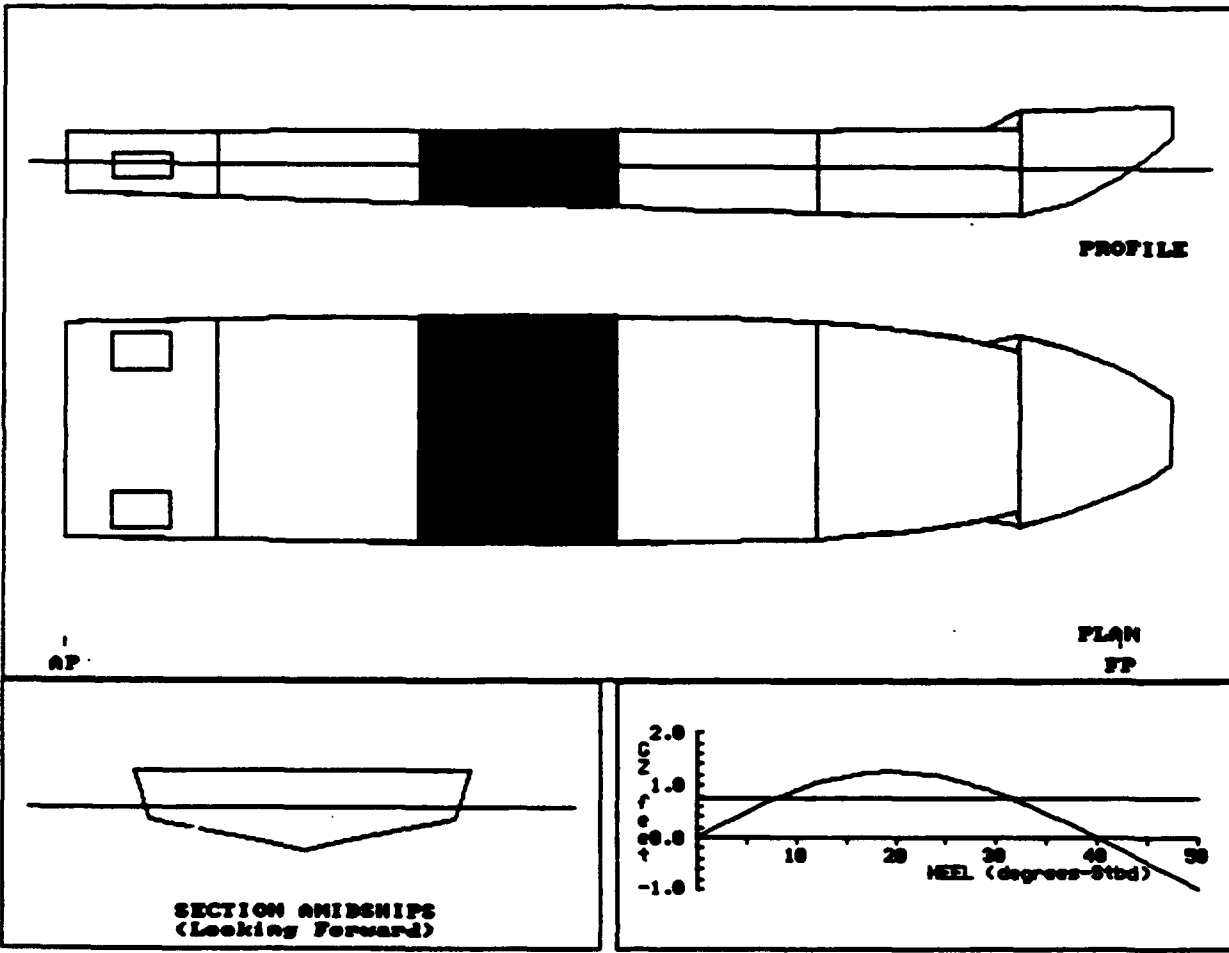

DPRT004A:
 80' SHUTTLE BOAT

COMPARTMENT FLOODING SUMMARY

At 0.0o Heel	PERM.	FLOODED WTR LTons	% FULL (Damaged)	% FULL (Intact)	SP.VOL. ft ³ /LT	OUTFLOW LTons
A/C ETC	0.85	12.7	FREE	0.0	----	----
Totals		12.7				

INTACT DATA

Draft at AP = 5.120 ft	KMT = 19.471 ft	LCG = 41.705A ft-FP
Draft at FP = 4.650 ft	VCG = 10.900 ft	LCB = 41.752A ft-FP
Displacement = 89.4 LTons	GMT = 8.571 ft	TCG = 0.000 ft-CL

DRAFT/GZ DATA

HEEL degrees	RIGHTING ARM ft	DRAFT AFT ft	DRAFT FWD ft	FLOODED WATER LTons
0.00	0.000	5.450	4.957	12.7
5.00S	0.477	5.457	4.923	12.7
10.00S	0.906	5.445	4.828	12.8
20.00S	1.250	5.124	4.462	13.8
25.00S	1.137	4.939	4.177	14.4
30.00S	0.851	4.783	3.871	14.9
40.00S	0.008	4.510	3.203	15.9
50.00S	-0.987	4.242	2.295	16.7

Note: Drafts are measured at A.P. and F.P along ship's centerline

GZ SUMMARY (Evaluated per IMO (SOLAS'90) Rules for Passenger Ships)
 Available Required

Static Heel Angle	0.00 deg	7.00 deg
Angle at Maximum GZ	21.00S deg	
Maximum GZ	1.250 ft	0.740 ft
Range of Positive GZ	40.08 deg	15.00 deg
Gmt (upright damaged)	5.460 ft	
Righting Area (0.00-7.00)	18.585 ft-deg	2.820 ft-deg

DPRT005A:
 80' SHUTTLE BOAT

Damaged Compartments:
 ENGINE ROOM

	DISPLACEMENT LTons	DRAFT AFT ft	DRAFT FWD ft	TRIM ft	HEEL deg.	UPRIGHT Gmt ft
INTACT	89.4	5.120	4.650	0.470A	0.00	8.571
DAMAGED	114.3	6.589	4.172	2.417A	0.16S	5.339

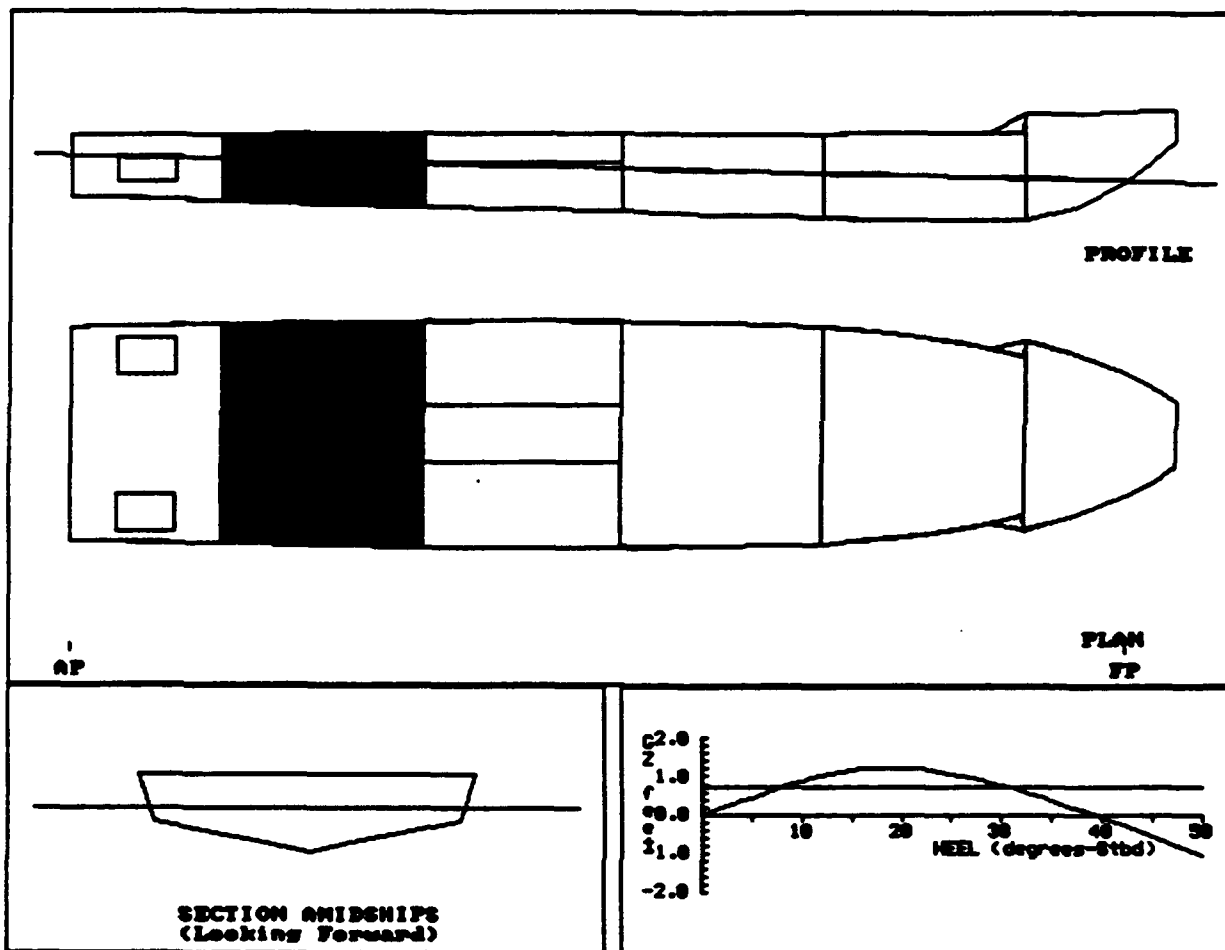

DPRT005A:
 80' SHUTTLE BOAT

COMPARTMENT FLOODING SUMMARY

At 0.2oS Heel	PERM.	FLOODED WTR LTons	% FULL (Damaged)	% FULL (Intact)	SP.VOL. ft ³ /LT	OUTFLOW LTons
ENGINE ROOM	0.85	25.0	FREE	0.0	----	----
Totals		25.0				

INTACT DATA

Draft at AP = 5.120 ft	KMt = 19.471 ft	LCG = 41.705A ft-FP
Draft at FP = 4.650 ft	VCG = 10.900 ft	LCB = 41.752A ft-FP
Displacement = 89.4 LTons	GMT = 8.571 ft	TCG = 0.000 ft-CL

DRAFT/GZ DATA

HEEL degrees	RIGHTING ARM ft	DRAFT AFT ft	DRAFT FWD ft	FLOODED WATER LTons
0.00	-0.015	6.588	4.173	25.0
5.00S	0.448	6.613	4.128	25.2
10.00S	0.881	6.629	4.011	25.4
20.00S	1.238	6.760	3.370	26.0
25.00S	1.083	6.926	2.892	26.1
30.00S	0.778	7.136	2.372	26.2
40.00S	-0.080	7.699	1.167	26.3
50.00S	-1.080	8.520	-0.373	26.3

Note: Drafts are measured at A.P. and F.P along ship's centerline

GZ SUMMARY (Evaluated per IMO (SOLAS'90) Rules for Passenger Ships)

	Available	Required
Static Heel Angle	0.16S deg	7.00 deg
Angle at Maximum GZ	20.00S deg	
Maximum GZ	1.242 ft	0.740 ft
Range of Positive GZ	39.00 deg	15.00 deg
Righting Area (0.16-4.00)	18.177 ft-deg	2.820 ft-deg

DPR006A:
 80' SHUTTLE BOAT

Imaged Compartments:
 LAZARETTE

	DISPLACEMENT LTons	DRAFT AFT ft	DRAFT FWD ft	TRIM ft	HEEL deg.	UPRIGHT GMT ft
INTACT	89.4	5.120	4.650	0.470A	0.00	8.571
DAMAGED	110.1	6.948	3.424	3.524A	0.21P	5.756

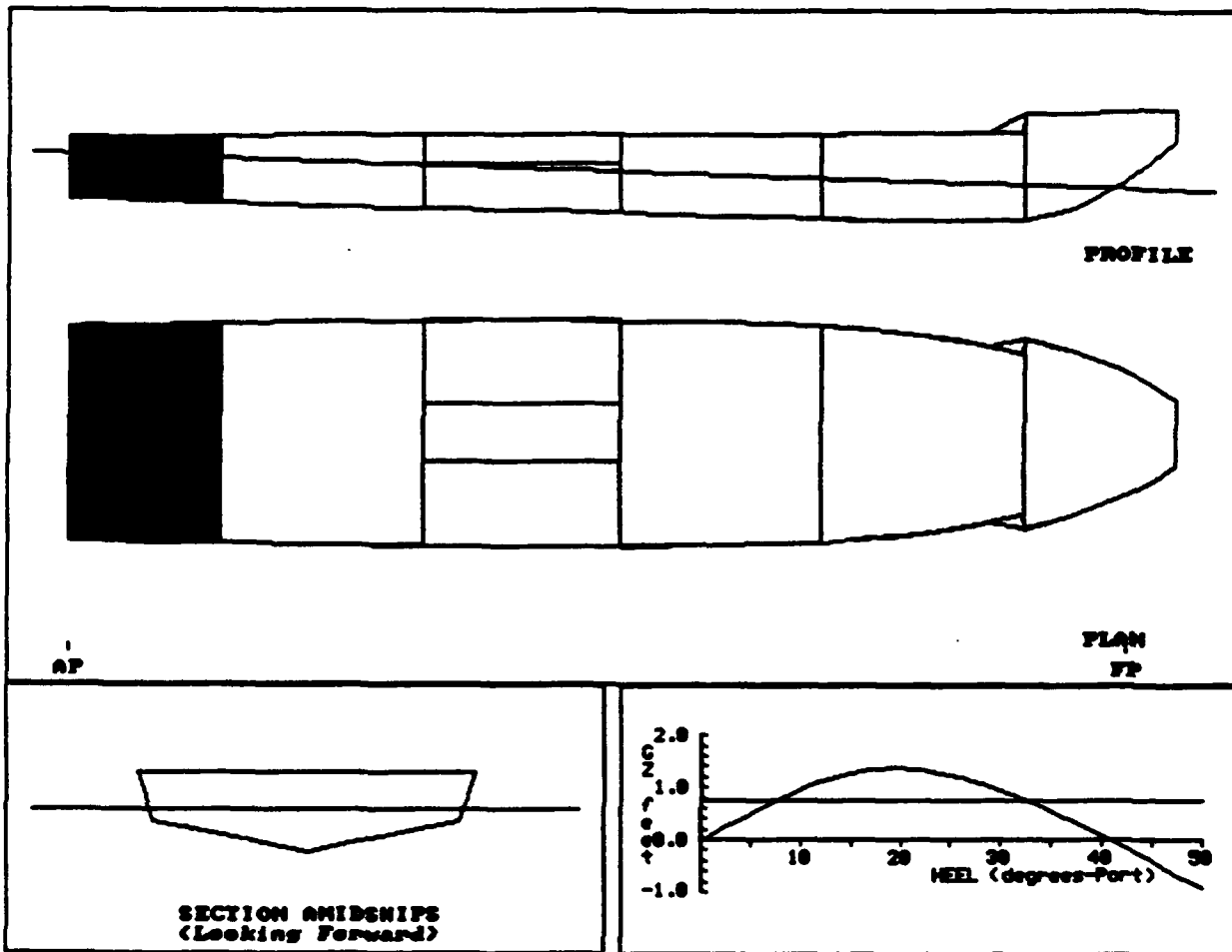

DPR006A:
80' SHUTTLE BOAT

COMPARTMENT FLOODING SUMMARY

At 0.20P Heel	PERM.	FLOODED WTR LTons	% FULL (Damaged)	% FULL (Intact)	SP.VOL. ft3/LT	OUTFLOW LTons
LAZARETTE	0.95	20.7	FREE	0.0	----	----
Totals		20.7				

INTACT DATA

Draft at AP = 5.120 ft	KMT = 19.471 ft	LCG = 41.705A ft-FP
Draft at FP = 4.650 ft	VCG = 10.900 ft	LCB = 41.752A ft-FP
Displacement = 89.4 LTons	GMT = 8.571 ft	TCG = 0.000 ft-CL

DRAFT/GZ DATA

HEEL degrees	RIGHTING ARM ft	DRAFT AFT ft	DRAFT FWD ft	FLOODED WATER LTons
0.00	-0.021	6.945	3.428	20.7
5.00P	0.488	7.023	3.334	21.5
10.00P	0.957	7.135	3.124	22.6
20.00P	1.370	7.385	2.340	22.5
25.00P	1.232	7.596	1.785	22.3
30.00P	0.936	7.887	1.135	22.2
40.00P	0.088	8.683	-0.412	22.1
50.00P	-0.938	9.941	-2.596	22.2

Note: Drafts are measured at A.P. and F.P along ship's centerline

GZ SUMMARY (Evaluated per IMO (SOLAS'90) Rules for Passenger Ships)

	Available	Required
Static Heel Angle	0.21P deg	7.00 deg
Angle at Maximum GZ	21.00P deg	
Maximum GZ	1.370 ft	0.740 ft
Range of Positive GZ	40.69 deg	15.00 deg
Righting Area (0.21-7.00)	19.883 ft-deg	2.820 ft-deg

DPR007A:
 80' SHUTTLE BOAT

amaged Compartments:
 LAZARETTE SEWAGE TK ST

	DISPLACEMENT LTons	DRAFT AFT ft	DRAFT FWD ft	TRIM ft	HEEL deg.	UPRIGHT GMT ft
INTACT	89.4	5.120	4.650	0.470A	0.00	8.571
DAMAGED	112.0	7.123	3.297	3.826A	0.70S	5.740

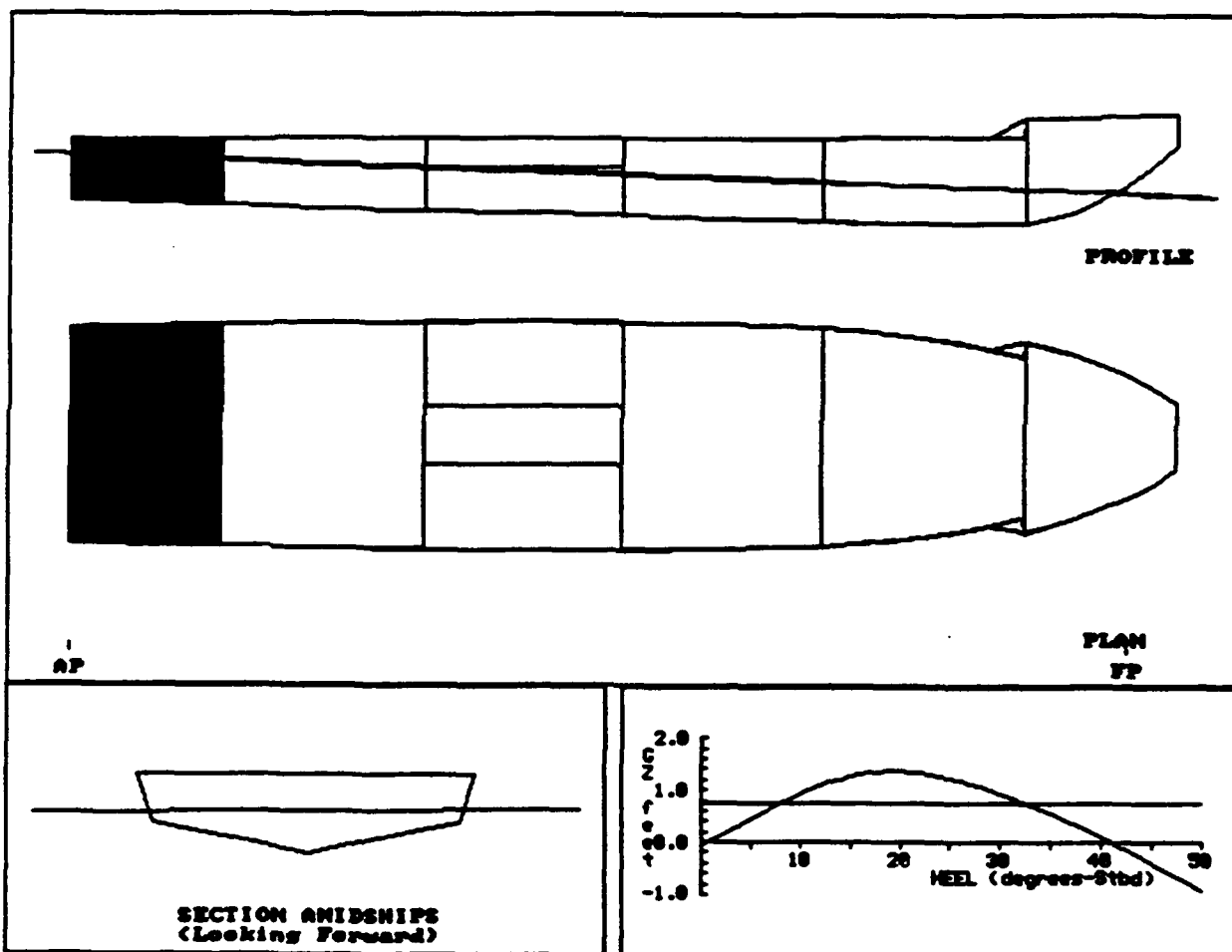

DPRT007A:
 80' SHUTTLE BOAT

COMPARTMENT FLOODING SUMMARY

At 0.7oS Heel	PERM.	FLOODED WTR LTons	% FULL (Damaged)	% FULL (Intact)	SP.VOL. ft3/LT	OUTFLOW LTons
LAZARETTE	0.95	21.6	FREE	0.0	----	----
SEWAGE TK ST	0.95	1.1	FREE	10.0	35.0063	0.1
Totals		22.7				0.1

INTACT DATA

Draft at AP = 5.120 ft	KMT = 19.471 ft	LCG = 41.705A ft-FP
Draft at FP = 4.650 ft	VCG = 10.900 ft	LCB = 41.752A ft-FP
Displacement = 89.4 LTons	GMT = 8.571 ft	TCG = 0.000 ft-CL

DRAFT/GZ DATA

HEEL degrees	RIGHTING ARM ft	DRAFT AFT ft	DRAFT FWD ft	FLOODED WATER LTons
0.00	-0.071	7.122	3.303	22.8
5.00S	0.439	7.136	3.251	22.8
10.00S	0.921	7.192	3.078	23.2
20.00S	1.365	7.354	2.351	22.3
25.00S	1.235	7.537	1.812	21.9
30.00S	0.943	7.807	1.172	21.8
40.00S	0.101	8.570	-0.360	21.7
50.00S	-0.920	9.779	-2.517	21.8

Note: Drafts are measured at A.P. and F.P along ship's centerline

GZ SUMMARY (Evaluated per IMO (SOLAS'90) Rules for Passenger Ships)
 Available Required

Static Heel Angle	0.70S deg	7.00 deg
Angle at Maximum GZ	21.00S deg	
Maximum GZ	1.365 ft	0.740 ft
Range of Positive GZ	40.33 deg	15.00 deg
Righting Area (0.70-3.00)	19.244 ft-deg	2.820 ft-deg

DPR008A:
 80' SHUTTLE BOAT

Imaged Compartments:
 A/C ETC FUELTKS

	DISPLACEMENT LTons	DRAFT AFT ft	DRAFT FWD ft	TRIM ft	HEEL deg.	UPRIGHT GMT ft
INTACT	89.4	5.120	4.650	0.470A	0.00	8.571
DAMAGED	101.4	5.434	4.941	0.492A	0.00	6.004

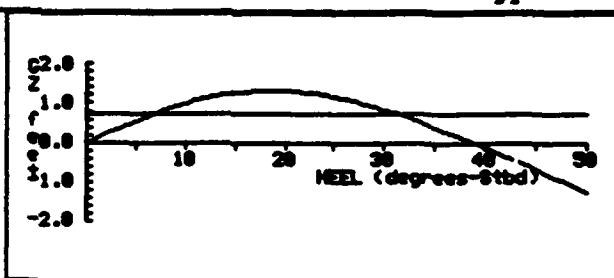
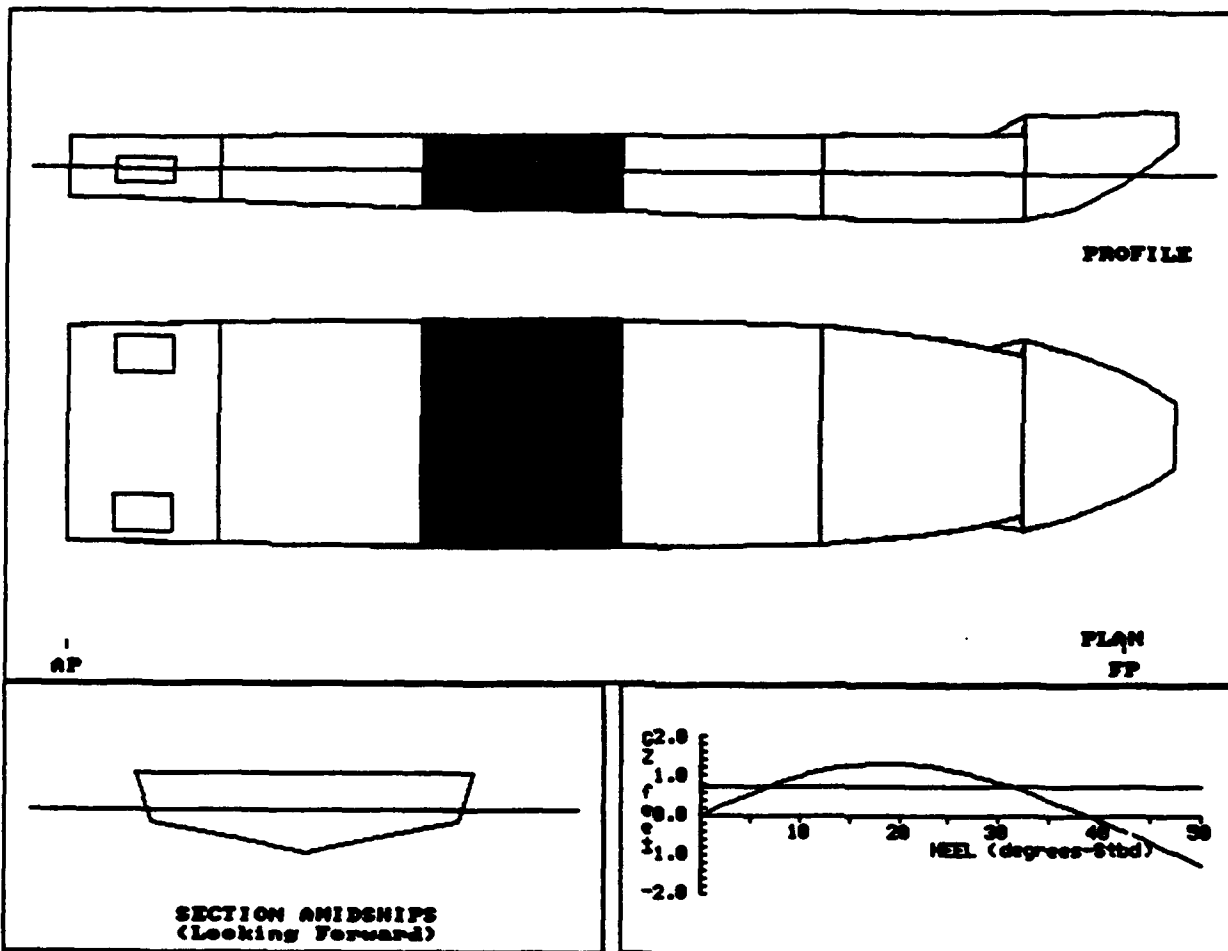

**DPRTOOSA:
 80' SHUTTLE BOAT**

COMPARTMENT FLOODING SUMMARY

At 0.0o Heel	PERM.	FLOODED WTR LTons	% FULL (Damaged)	% FULL (Intact)	SP.VOL. ft3/LT	OUTFLOW LTons
A/C ETC	0.85	12.6	FREE	0.0	----	----
FUELTKNS	0.95	8.6	FREE	100.0	39.0000	9.1
Totals		21.2				9.1

INTACT DATA

Draft at AP = 5.120 ft	Kmt = 19.471 ft	LCG = 41.705A ft-FP
Draft at FP = 4.650 ft	VCG = 10.900 ft	LCB = 41.752A ft-FP
Displacement = 89.4 LTons	Gmt = 8.571 ft	TCG = 0.000 ft-CL

DRAFT/GZ DATA

HEEL degrees	RIGHTING ARM ft	DRAFT AFT ft	DRAFT FWD ft	FLOODED WATER LTons
0.00	0.000	5.434	4.941	21.2
5.00S	0.524	5.440	4.907	21.1
10.00S	0.990	5.423	4.808	21.1
20.00S	1.324	5.058	4.418	21.2
25.00S	1.179	4.823	4.117	21.1
30.00S	0.843	4.601	3.791	21.0
40.00S	-0.129	4.125	3.080	20.7
50.00S	-1.258	3.578	2.117	20.4

Note: Drafts are measured at A.P. and F.P along ship's centerline

GZ SUMMARY (Evaluated per IMO (SOLAS'90) Rules for Passenger Ships)

	Available	Required
Static Heel Angle	0.00 deg	7.00 deg
Angle at Maximum GZ	20.00S deg	
Maximum GZ	1.328 ft	0.740 ft
Range of Positive GZ	38.80 deg	15.00 deg
Gmt (upright damaged)	6.004 ft	
Righting Area (0.00-%.00)	20.044 ft-deg	2.820 ft-deg

RTRN001B:
 80' SHUTTLE BOAT

Managed Compartments:
 FOREPEAK

	DISPLACEMENT LTons	DRAFT AFT ft	DRAFT FWD ft	TRIM ft	HEEL deg.	UPRIGHT GMT ft
INTACT	83.1	5.080	4.330	0.750A	0.00	8.849
DAMAGED	84.5	4.989	4.539	0.450A	0.00	8.728

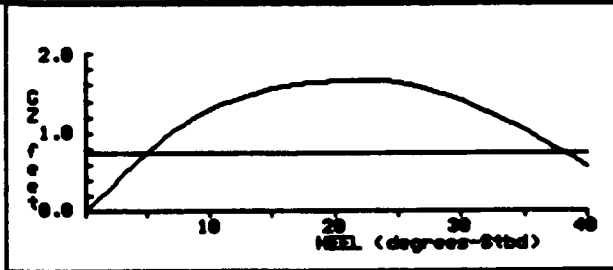
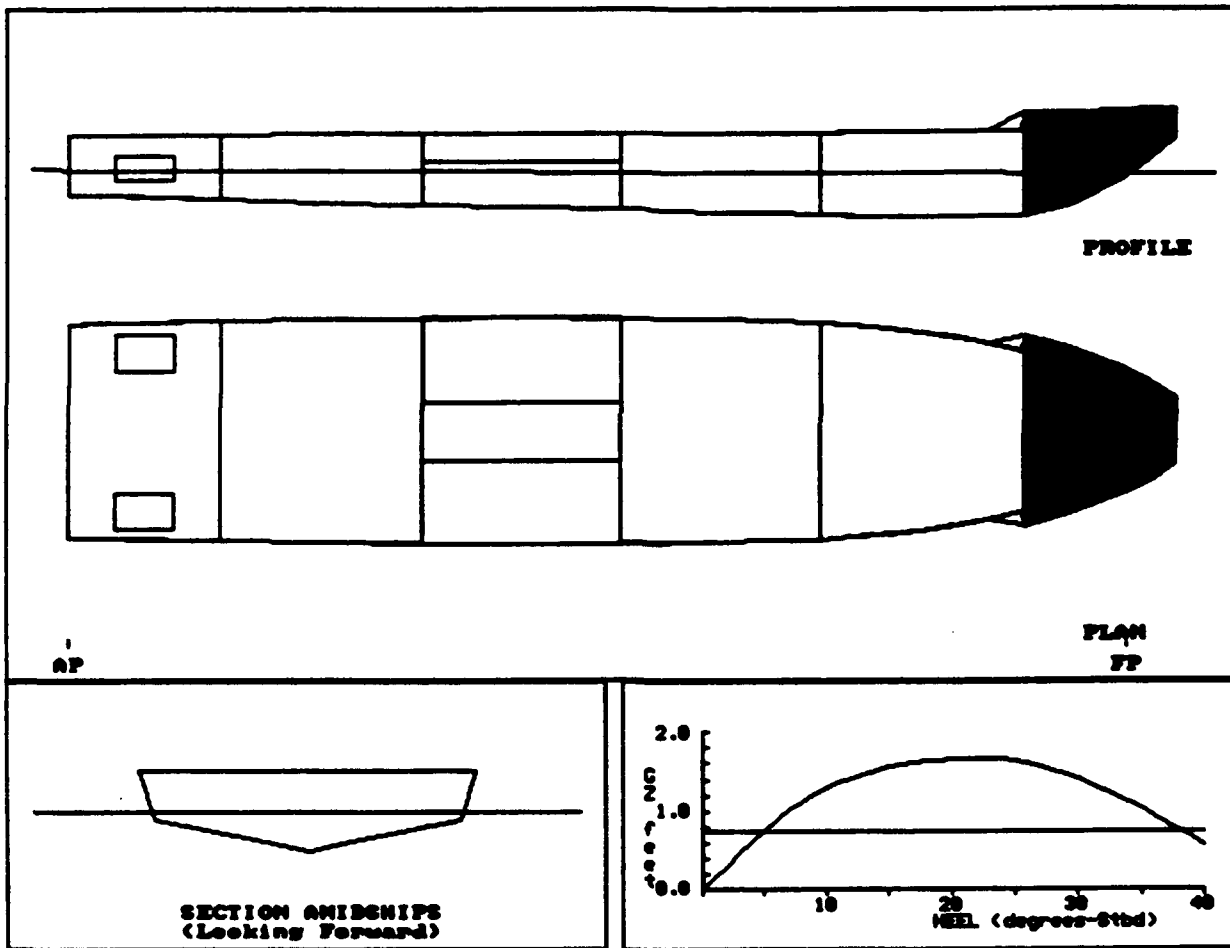

RTRN001B:
 80' SHUTTLE BOAT

COMPARTMENT FLOODING SUMMARY

At 0.0o Heel	PERM.	FLOODED WTR LTons	% FULL (Damaged)	% FULL (Intact)	SP.VOL. ft3/LT	OUTFLOW LTons
FOREPEAK	0.95	1.4	FREE	0.0	----	----
Totals		1.4				

INTACT DATA

Draft at AP = 5.080 ft	KMt = 20.249 ft	LCG = 42.296A ft-FP
Draft at FP = 4.330 ft	VCG = 11.400 ft	LCB = 42.377A ft-FP
Displacement = 83.1 LTons	GMT = 8.849 ft	TCG = 0.000 ft-CL

DRAFT/GZ DATA

HEEL degrees	RIGHTING ARM ft	DRAFT AFT ft	DRAFT FWD ft	FLOODED WATER LTons
0.00	0.000	4.989	4.539	1.4
5.00S	0.749	5.000	4.488	1.4
7.00S	1.005	4.999	4.436	1.4
10.00S	1.285	4.943	4.361	1.3
15.00S	1.549	4.757	4.175	1.2
20.00S	1.655	4.452	3.934	1.1
22.00S	1.669	4.295	3.825	1.0
30.00S	1.409	3.687	3.230	0.8
35.00S	1.035	3.293	2.809	0.6
40.00S	0.562	2.852	2.369	0.5

Note: Drafts are measured at A.P. and F.P along ship's centerline

GZ SUMMARY (Evaluated per IMO (SOLAS'90) Rules for Passenger Ships)

	Available	Required
Static Heel Angle	0.00 deg	7.00 deg
Angle at Maximum GZ	23.00S deg	
Maximum GZ	1.669 ft	0.740 ft
Range of Positive GZ	40.00 deg	15.00 deg
Gmt (upright damaged)	8.728 ft	
Righting Area (0.00-%.00)	25.673 ft-deg	2.820 ft-deg

RTRN002B:
 80' SHUTTLE BOAT

Imaged Compartments:
 VOID1

	DISPLACEMENT LTons	DRAFT AFT ft	DRAFT FWD ft	TRIM ft	HEEL deg.	UPRIGHT GMT ft
INTACT	83.1	5.080	4.330	0.750A	0.00	8.849
DAMAGED	101.4	4.424	6.214	1.790F	0.00	8.255

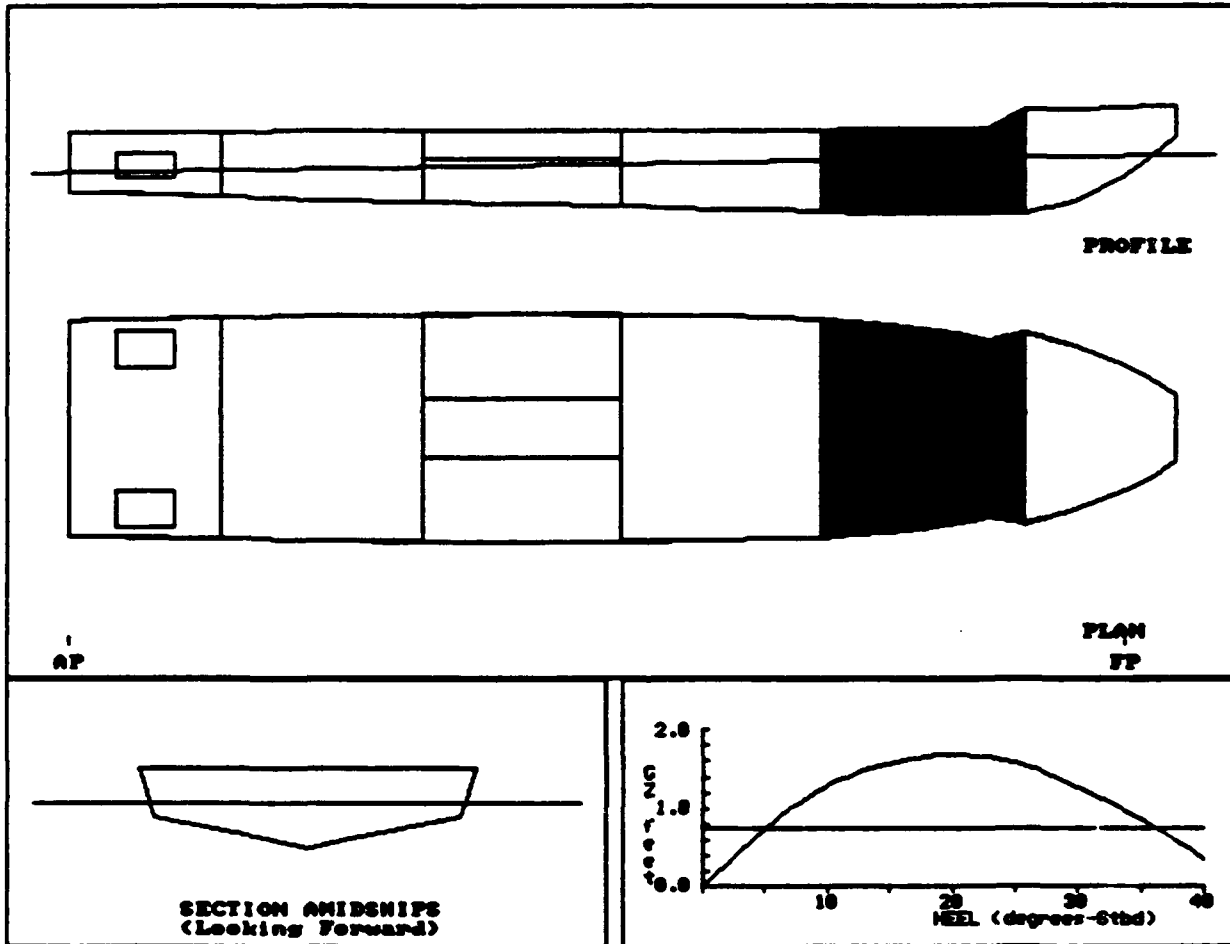

RTRN002B:
 80' SHUTTLE BOAT

COMPARTMENT FLOODING SUMMARY

At 0.0o Heel	PERM.	FLOODED WTR LTons	% FULL (Damaged)	% FULL (Intact)	SP.VOL. ft3/LT	OUTFLOW LTons
VOID1	0.95	18.3	FREE	0.0	----	----
Totals		18.3				

INTACT DATA

Draft at AP = 5.080 ft	KMT = 20.249 ft	LCG = 42.296A ft-FP
Draft at FP = 4.330 ft	VCG = 11.400 ft	LCB = 42.377A ft-FP
Displacement = 83.1 LTons	Gmt = 8.849 ft	TCG = 0.000 ft-CL

DRAFT/GZ DATA

HEEL degrees	RIGHTING ARM ft	DRAFT AFT ft	DRAFT FWD ft	FLOODED WATER LTons
0.00	0.000	4.424	6.214	18.3
5.00S	0.722	4.426	6.189	18.3
7.00S	0.983	4.403	6.185	18.4
10.00S	1.280	4.323	6.173	18.5
15.00S	1.569	4.077	6.117	18.8
20.00S	1.684	3.718	6.002	19.0
22.00S	1.671	3.546	5.958	19.1
30.00S	1.274	2.760	5.863	19.4
35.00S	0.855	2.265	5.737	19.3
40.00S	0.356	1.730	5.590	19.1

Note: Drafts are measured at A.P. and F.P along ship's centerline

GZ SUMMARY (Evaluated per IMO (SOLAS'90) Rules for Passenger Ships)

	Available	Required
Static Heel Angle	0.00 deg	7.00 deg
Angle at Maximum GZ	21.00S deg	
Maximum GZ	1.684 ft	0.740 ft
Range of Positive GZ	40.00 deg	15.00 deg
Gmt (upright damaged)	8.255 ft	
Righting Area (0.00-%.00)	25.717 ft-deg	2.820 ft-deg

RTRN003B:
 80' SHUTTLE BOAT

Imaged Compartments:
 VOID2

	DISPLACEMENT LTons	DRAFT AFT ft	DRAFT FWD ft	TRIM ft	HEEL deg.	UPRIGHT Gmt ft
INTACT	83.1	5.080	4.330	0.750A	0.00	8.849
DAMAGED	106.4	4.953	5.831	0.878F	0.00	6.515

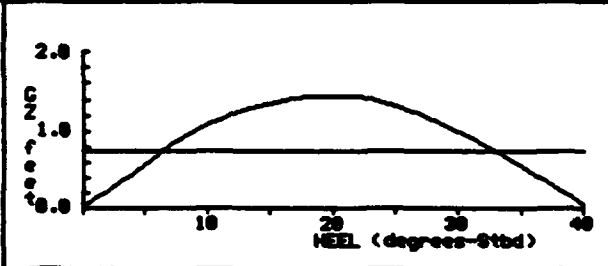
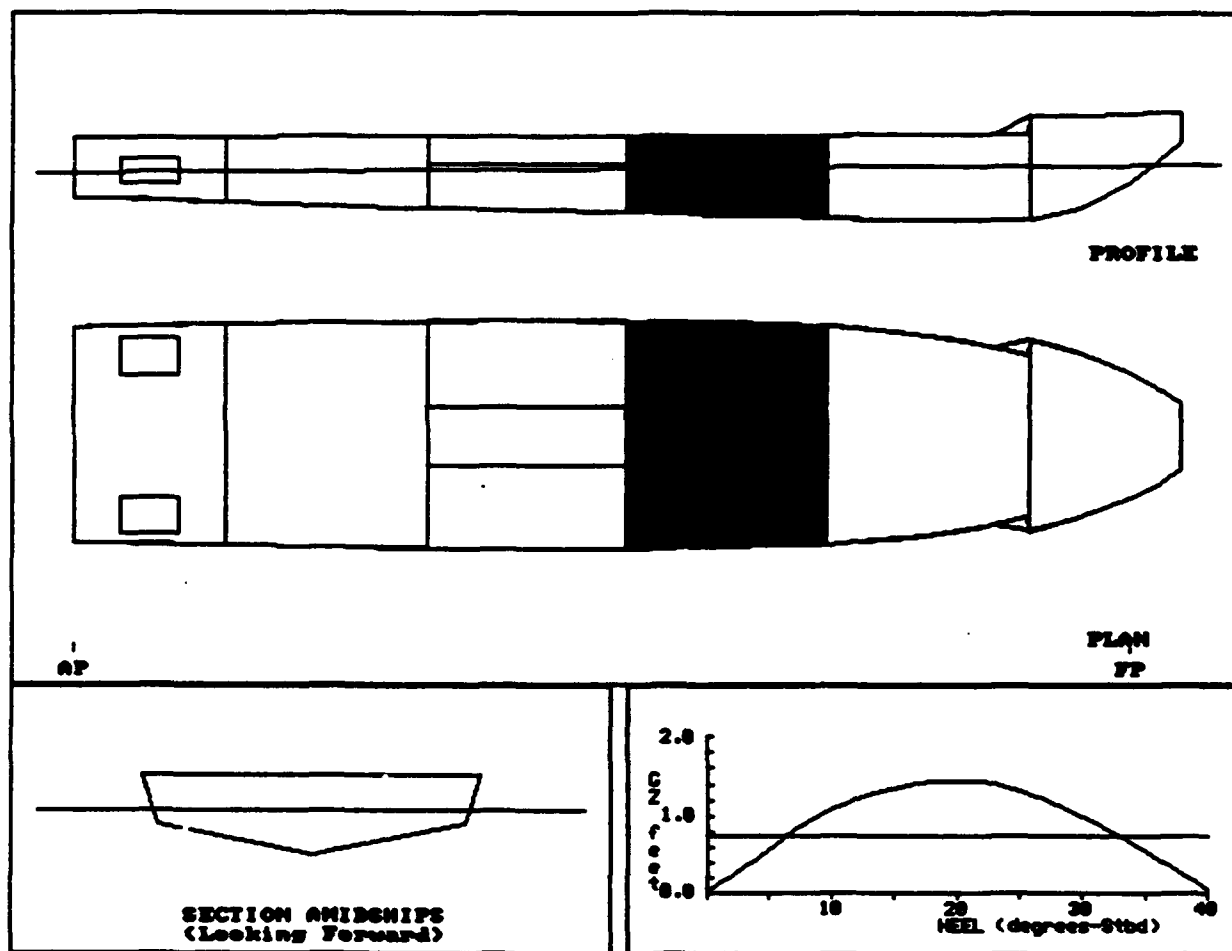

RTRN003B:
 80' SHUTTLE BOAT

COMPARTMENT FLOODING SUMMARY

At 0.0o Heel	PERM.	FLOODED WTR LTons	% FULL (Damaged)	% FULL (Intact)	SP.VOL. ft3/LT	OUTFLOW LTons
VOID2	0.95	23.3	FREE	0.0	----	----
Totals		23.3				

INTACT DATA

Draft at AP = 5.080 ft KMT = 20.249 ft LCG = 42.296A ft-FP
 Draft at FP = 4.330 ft VCG = 11.400 ft LCB = 42.377A ft-FP
 Displacement = 83.1 LTons GMT = 8.849 ft TCG = 0.000 ft-CL

DRAFT/GZ DATA

HEEL degrees	RIGHTING ARM ft	DRAFT AFT ft	DRAFT FWD ft	FLOODED WATER LTons
0.00	0.000	4.953	5.831	23.3
5.00S	0.573	4.954	5.806	23.3
7.00S	0.805	4.953	5.785	23.3
10.00S	1.080	4.920	5.735	23.2
15.00S	1.342	4.741	5.635	23.3
20.00S	1.448	4.450	5.470	23.4
22.00S	1.429	4.315	5.396	23.4
30.00S	0.989	3.793	5.099	23.1
35.00S	0.551	3.460	4.890	22.9
40.00S	0.059	3.119	4.622	22.6

Note: Drafts are measured at A.P. and F.P along ship's centerline

GZ SUMMARY (Evaluated per IMO (SOLAS'90) Rules for Passenger Ships)

	Available	Required
Static Heel Angle	0.00 deg	7.00 deg
Angle at Maximum GZ	21.00S deg	
Maximum GZ	1.448 ft	0.740 ft
Range of Positive GZ	40.00 deg	15.00 deg
Gmt (upright damaged)	6.515 ft	
Righting Area (0.00-7.00)	21.710 ft-deg	2.820 ft-deg

RTRN004B:
 80' SHUTTLE BOAT

Imaged Compartments:
 A/C ETC

	DISPLACEMENT LTons	DRAFT AFT ft	DRAFT FWD ft	TRIM ft	HEEL deg.	UPRIGHT GMT ft
INTACT	83.1	5.080	4.330	0.750A	0.00	8.849
DAMAGED	94.8	5.379	4.627	0.751A	0.00	5.548

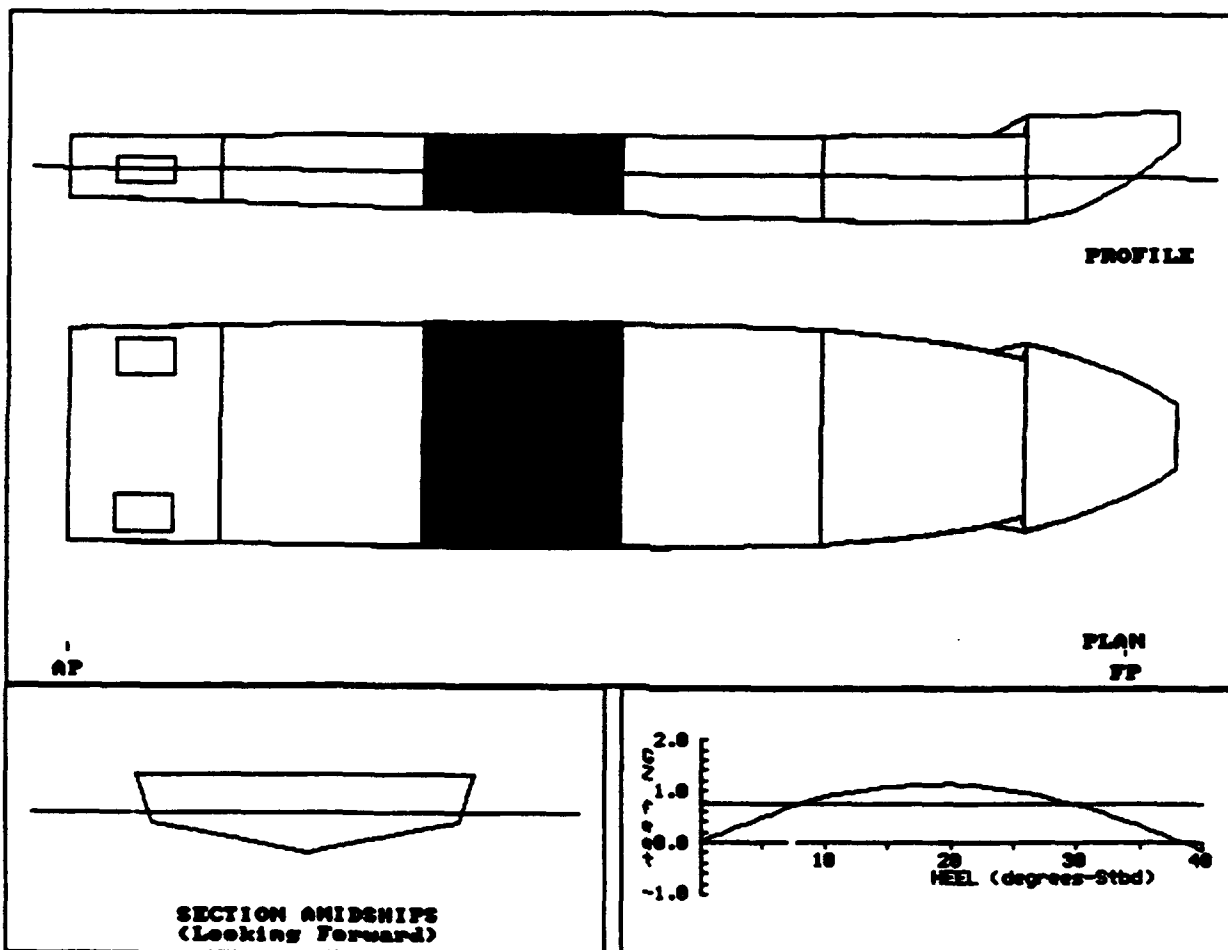

RTRN004B:
 80' SHUTTLE BOAT

COMPARTMENT FLOODING SUMMARY

At 0.0o Heel	PERM.	FLOODED WTR LTons	% FULL (Damaged)	% FULL (Intact)	SP.VOL. ft3/LT	OUTFLOW LTons
A/C ETC	0.85	11.7	FREE	0.0	----	----
Totals		11.7				

INTACT DATA

Draft at AP = 5.080 ft	KMT = 20.249 ft	LCG = 42.296A ft-FP
Draft at FP = 4.330 ft	VCG = 11.400 ft	LCB = 42.377A ft-FP
Displacement = 83.1 LTons	GMT = 8.849 ft	TCG = 0.000 ft-CL

DRAFT/GZ DATA

HEEL degrees	RIGHTING ARM ft	DRAFT AFT ft	DRAFT FWD ft	FLOODED WATER LTons
0.00	0.000	5.379	4.627	11.7
5.00S	0.480	5.388	4.585	11.7
7.00S	0.660	5.391	4.548	11.7
10.00S	0.878	5.370	4.477	11.8
15.00S	1.075	5.243	4.313	12.3
20.00S	1.138	5.011	4.099	13.0
22.00S	1.116	4.914	3.990	13.3
30.00S	0.731	4.588	3.459	14.3
35.00S	0.328	4.402	3.098	14.9
40.00S	-0.146	4.214	2.704	15.4

Note: Drafts are measured at A.P. and F.P along ship's centerline

GZ SUMMARY (Evaluated per IMO (SOLAS'90) Rules for Passenger Ships)

	Available	Required
Static Heel Angle	0.00 deg	7.00 deg
Angle at Maximum GZ	21.00S deg	
Maximum GZ	1.138 ft	0.740 ft
Range of Positive GZ	38.48 deg	15.00 deg
Gmt (upright damaged)	5.548 ft	
Righting Area (0.00-3.00)	17.472 ft-deg	2.820 ft-deg

RTRN005B:
 80' SHUTTLE BOAT

Imaged Compartments:
 ENGINE ROOM

	DISPLACEMENT LTons	DRAFT AFT ft	DRAFT FWD ft	TRIM ft	HEEL deg.	UPRIGHT GMT ft
INTACT	83.1	5.080	4.330	0.750A	0.00	8.849
DAMAGED	106.8	6.484	3.865	2.619A	0.15S	5.343

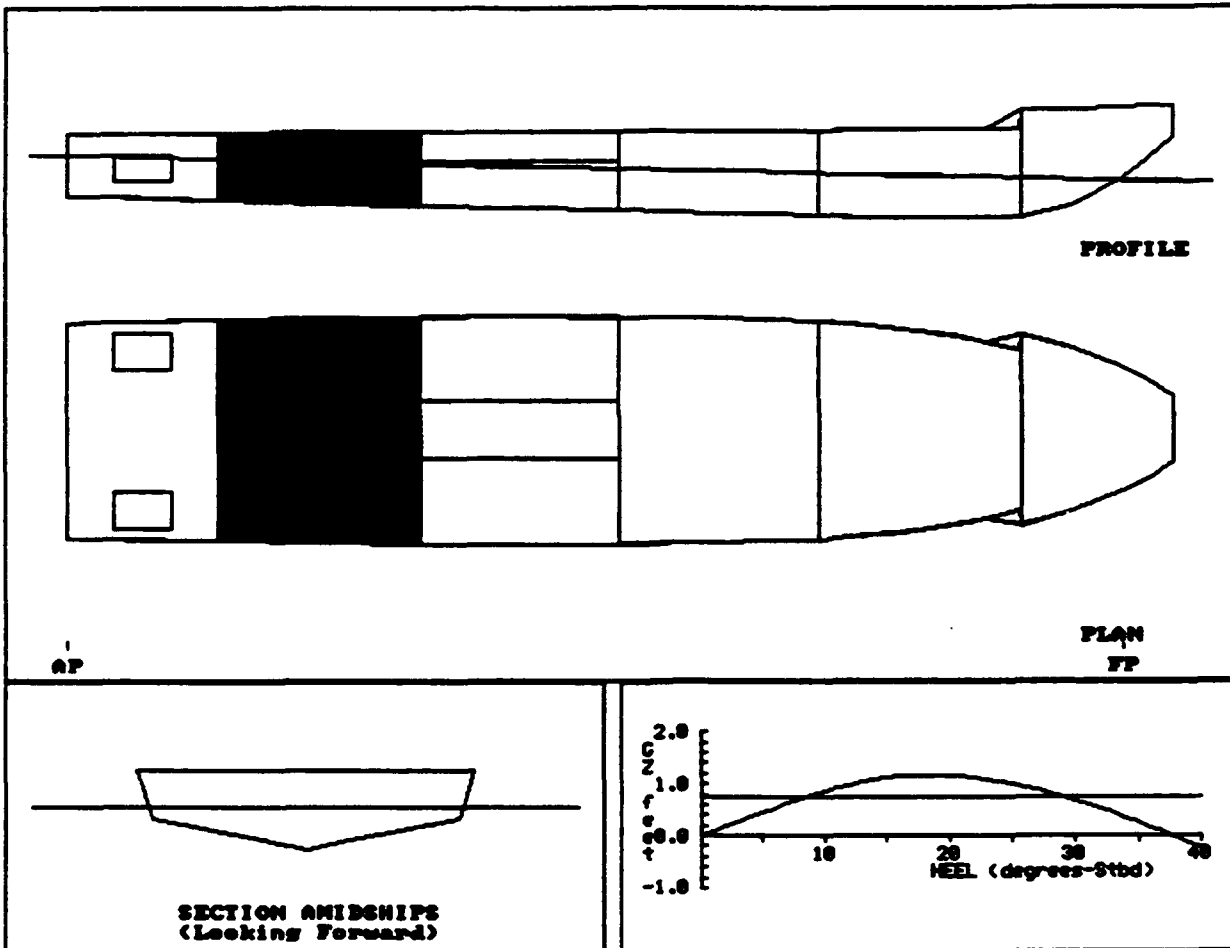

RTRM005B:
 80' SHUTTLE BOAT

COMPARTMENT FLOODING SUMMARY

At 0.1oS Heel	PERM.	FLOODED WTR LTons	% FULL (Damaged)	% FULL (Intact)	SP.VOL. ft ³ /LT	OUTFLOW LTons
ENGINE ROOM	0.85	23.7	FREE	0.0	----	----
Totals		23.7				

INTACT DATA

Draft at AP = 5.080 ft	KMT = 20.249 ft	LCG = 42.296A ft-FP
Draft at FP = 4.330 ft	VCG = 11.400 ft	LCB = 42.377A ft-FP
Displacement = 83.1 LTons	GMT = 8.849 ft	TCG = 0.000 ft-CL

DRAFT/GZ DATA

HEEL degrees	RIGHTING ARM ft	DRAFT AFT ft	DRAFT FWD ft	FLOODED WATER LTons
0.00	-0.014	6.483	3.866	23.7
5.00S	0.447	6.511	3.812	24.0
7.00S	0.624	6.513	3.779	24.0
10.00S	0.856	6.523	3.682	24.1
15.00S	1.119	6.539	3.420	24.4
20.00S	1.160	6.592	3.022	24.8
22.00S	1.118	6.618	2.842	24.8
30.00S	0.678	6.826	1.994	25.0
35.00S	0.256	7.019	1.380	25.1
40.00S	-0.226	7.261	0.696	25.1

Note: Drafts are measured at A.P. and F.P along ship's centerline

GZ SUMMARY (Evaluated per IMO (SOLAS'90) Rules for Passenger Ships)

	Available	Required
Static Heel Angle	0.15S deg	7.00 deg
Angle at Maximum GZ	19.00S deg	
Maximum GZ	1.170 ft	0.740 ft
Range of Positive GZ	37.54 deg	15.00 deg
Righting Area (0.15-7.00)	17.476 ft-deg	2.820 ft-deg

RTRN006B:
 80' SHUTTLE BOAT

Imaged Compartments:
 LAZARETTE

	DISPLACEMENT LTons	DRAFT AFT ft	DRAFT FWD ft	TRIM ft	HEEL deg.	UPRIGHT GMT ft
INTACT	83.1	5.080	4.330	0.750A	0.00	8.849
DAMAGED	103.3	6.888	3.083	3.806A	0.20P	5.842

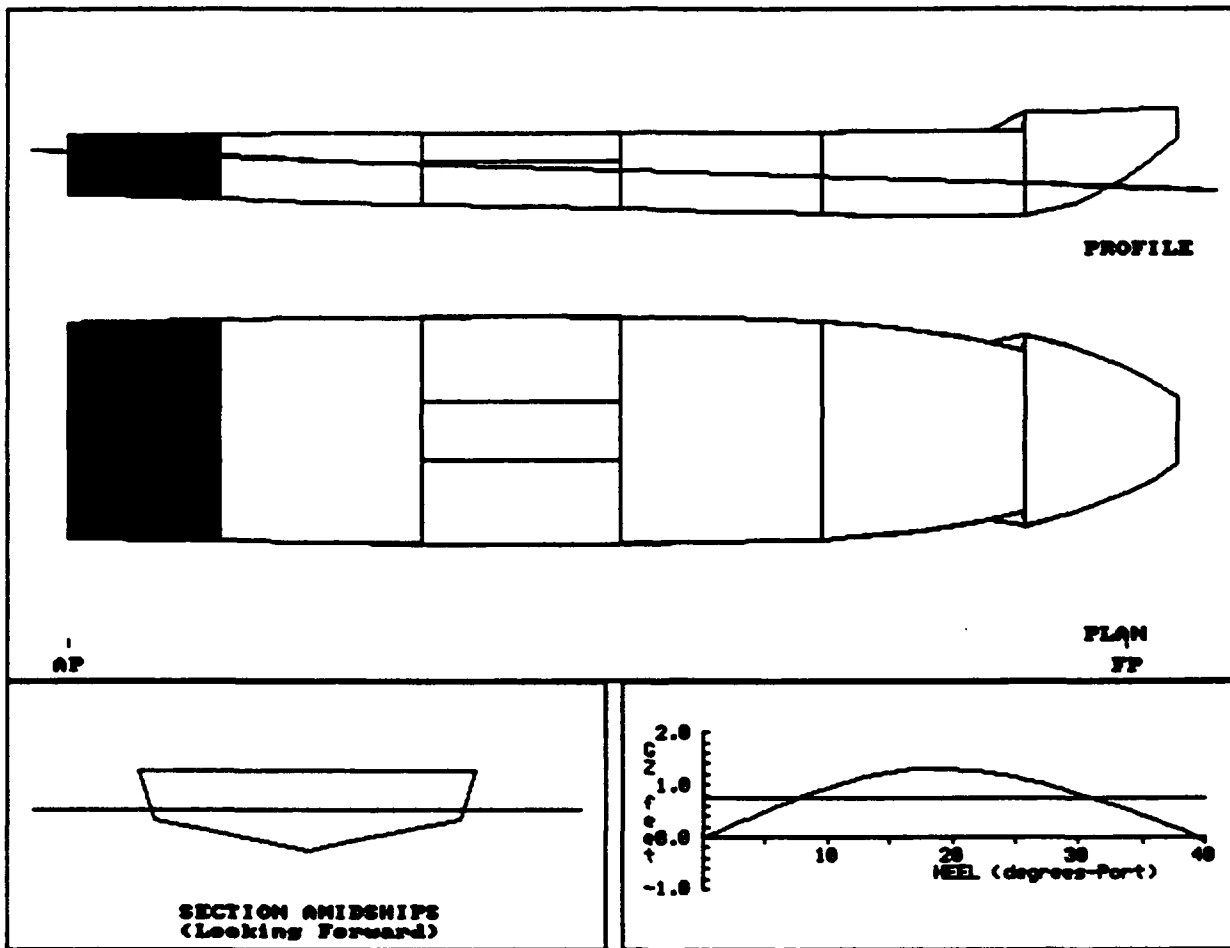

RTRN006B:
 80' SHUTTLE BOAT

COMPARTMENT FLOODING SUMMARY

At 0.20P Heel	PERM.	FLOODED WTR LTons	% FULL (Damaged)	% FULL (Intact)	SP.VOL. ft ³ /LT	OUTFLOW LTons
LAZARETTE	0.95	20.2	FREE	0.0	----	----
Totals		20.2				

INTACT DATA

Draft at AP = 5.080 ft	KMT = 20.249 ft	LCG = 42.296A ft-FP
Draft at FP = 4.330 ft	VCG = 11.400 ft	LCB = 42.377A ft-FP
Displacement = 83.1 LTons	GMT = 8.849 ft	TCG = 0.000 ft-CL

DRAFT/GZ DATA

HEEL degrees	RIGHTING ARM ft	DRAFT AFT ft	DRAFT FWD ft	FLOODED WATER LTons
0.00	-0.021	6.885	3.086	20.2
5.00P	0.489	6.968	2.982	21.1
7.00P	0.680	7.012	2.906	21.5
10.00P	0.936	7.079	2.752	22.1
15.00P	1.234	7.158	2.418	22.3
20.00P	1.298	7.260	1.957	22.0
22.00P	1.262	7.306	1.747	21.8
30.00P	0.834	7.623	0.726	21.4
35.00P	0.423	7.897	-0.021	21.3
40.00P	-0.060	8.267	-0.901	21.3

Note: Drafts are measured at A.P. and F.P along ship's centerline

GZ SUMMARY (Evaluated per IMO (SOLAS'90) Rules for Passenger Ships)

	Available	Required
Static Heel Angle	0.20P deg	7.00 deg
Angle at Maximum GZ	20.00P deg	
Maximum GZ	1.304 ft	0.740 ft
Range of Positive GZ	39.80 deg	15.00 deg
Righting Area (0.20-7.00)	19.278 ft-deg	2.820 ft-deg

RTRN007B:
 80' SHUTTLE BOAT

Imaged Compartments:

LAZARETTE SEWAGE TK ST

	DISPLACEMENT LTONS	DRAFT AFT ft	DRAFT FWD ft	TRIM ft	HEEL deg.	UPRIGHT GMT ft
INTACT	83.1	5.080	4.330	0.750A	0.00	8.849
DAMAGED	103.3	6.889	3.082	3.807A	0.21P	5.806

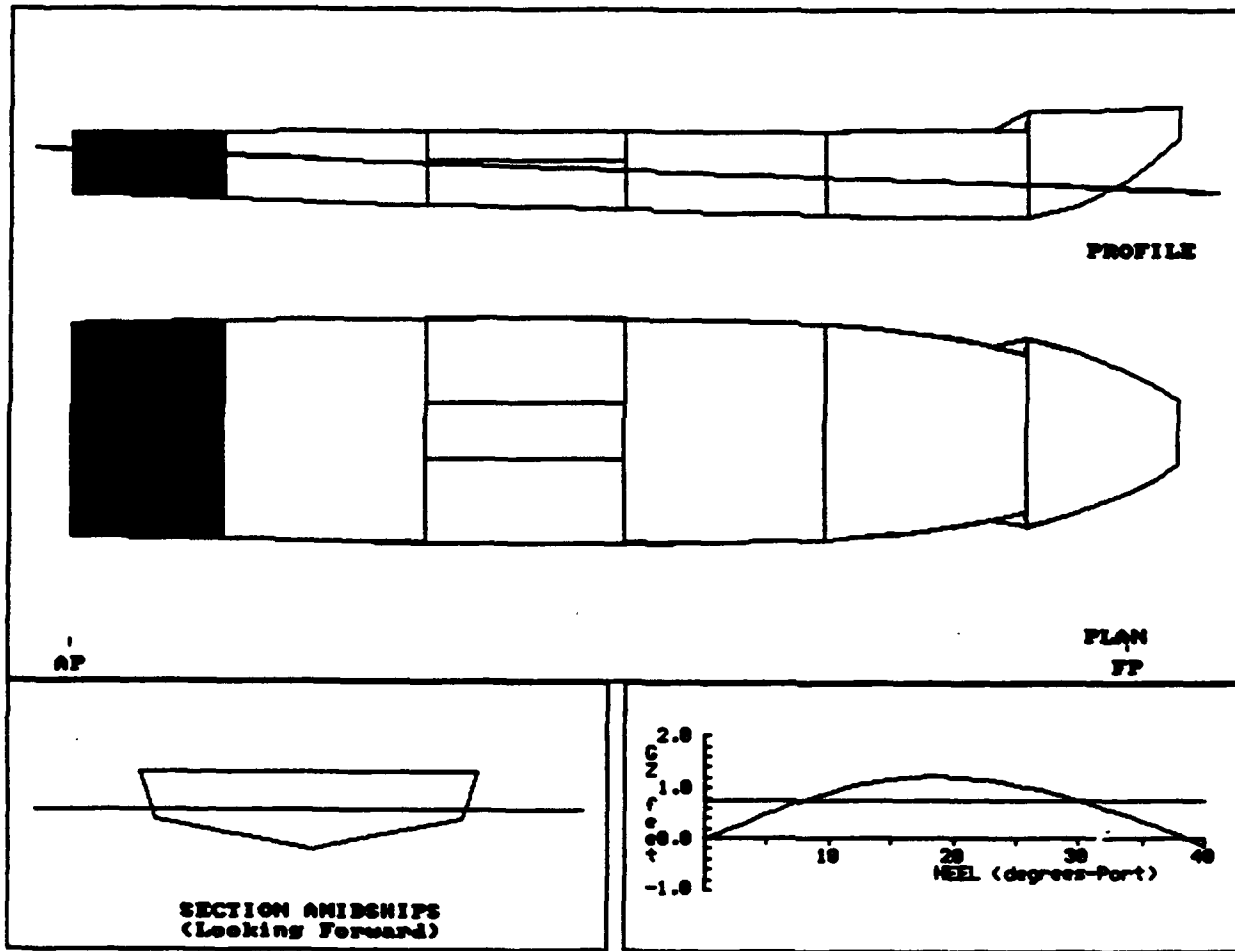

RTRN007B:
 80' SHUTTLE BOAT

COMPARTMENT FLOODING SUMMARY

At 0.2oP Heel	PERM.	FLOODED WTR LTons	% FULL (Damaged)	% FULL (Intact)	SP.VOL. ft ³ /LT	OUTFLOW LTons
LAZARETTE	0.95	20.2	FREE	0.0	----	----
SEWAGE TK ST	0.95	1.1	FREE	100.0	35.0063	1.1
Totals		21.4				1.1

INTACT DATA

Draft at AP = 5.080 ft	KMt = 20.249 ft	LCG = 42.296A ft-FP
Draft at FP = 4.330 ft	VCG = 11.400 ft	LCB = 42.377A ft-FP
Displacement = 83.1 LTons	GMT = 8.849 ft	TCG = 0.000 ft-CL

DRAFT/GZ DATA

HEEL degrees	RIGHTING ARM ft	DRAFT AFT ft	DRAFT FWD ft	FLOODED WATER LTons
0.00	-0.021	6.887	3.084	21.4
5.00P	0.474	6.926	3.013	21.7
7.00P	0.657	6.953	2.949	22.0
10.00P	0.898	6.988	2.818	22.3
15.00P	1.166	6.989	2.539	21.9
20.00P	1.210	6.991	2.142	21.1
22.00P	1.173	7.004	1.951	20.9
30.00P	0.752	7.203	0.994	20.4
35.00P	0.345	7.397	0.295	20.3
40.00P	-0.136	7.672	-0.528	20.3

Note: Drafts are measured at A.P. and F.P along ship's centerline

GZ SUMMARY (Evaluated per IMO (SOLAS'90) Rules for Passenger Ships)

	Available	Required
Static Heel Angle	0.21P deg	7.00 deg
Angle at Maximum GZ	20.00P deg	
Maximum GZ	1.218 ft	0.740 ft
Range of Positive GZ	38.40 deg	15.00 deg
Righting Area (0.21-3.00)	18.278 ft-deg	2.820 ft-deg

RTRN008B:
 80' SHUTTLE BOAT

Imaged Compartments:
 A/C ETC FUELTKNS

	DISPLACEMENT LTons	DRAFT AFT ft	DRAFT FWD ft	TRIM ft	HEEL deg.	UPRIGHT GMT ft
INTACT	83.1	5.080	4.330	0.750A	0.00	8.849
DAMAGED	103.8	5.615	4.847	0.769A	0.00	5.941

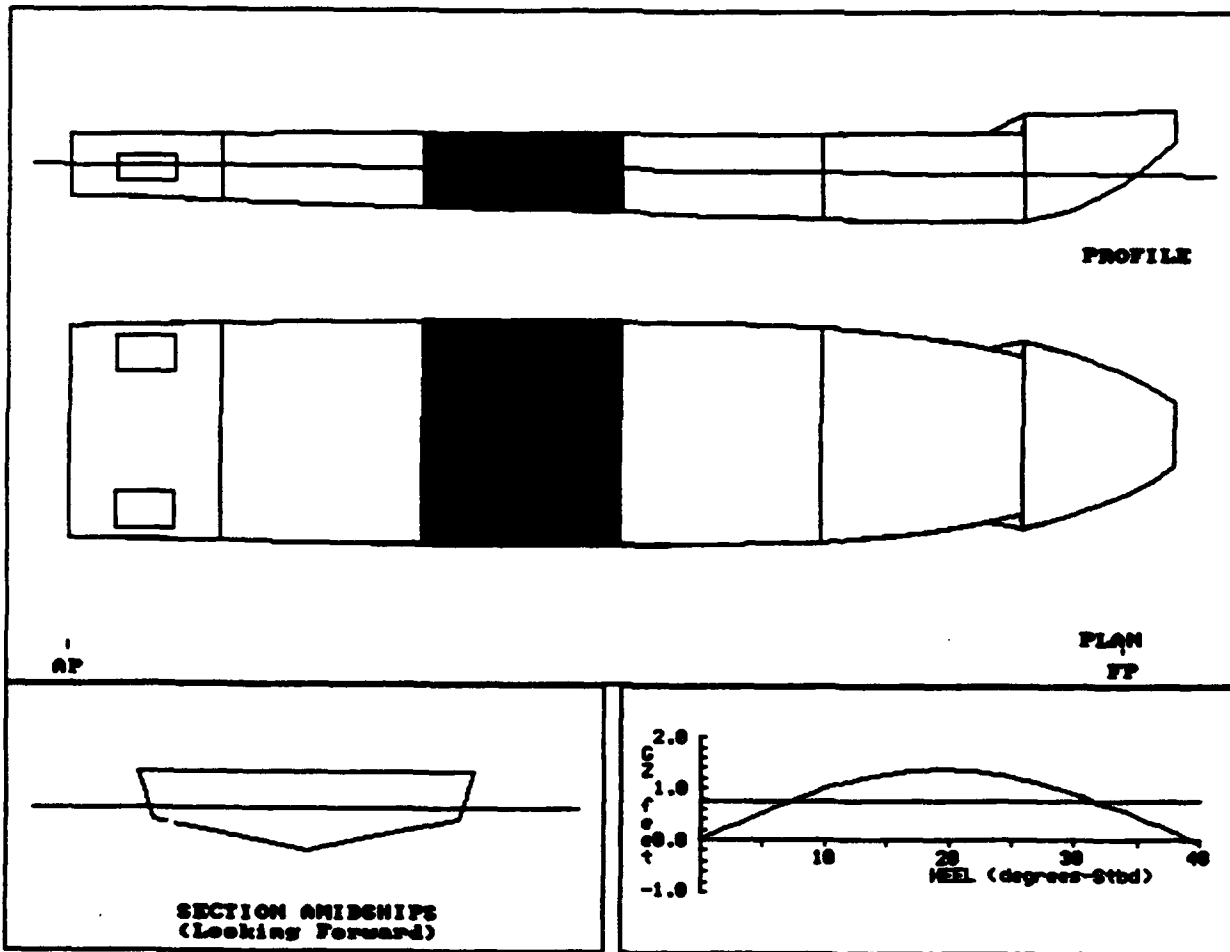

RTRN008B:
80' SHUTTLE BOAT

COMPARTMENT FLOODING SUMMARY

At 0.0o Heel	PERM.	FLOODED WTR LTons	% FULL (Damaged)	% FULL (Intact)	SP.VOL. ft3/LT	OUTFLOW LTons
A/C ETC	0.85	13.0	FREE	0.0	----	----
FUELTNKS	0.95	8.7	FREE	10.0	39.0000	0.9
Totals		21.7				0.9

INTACT DATA

Draft at AP = 5.080 ft Kmt = 20.249 ft LCG = 42.296A ft-FP
 Draft at FP = 4.330 ft VCG = 11.400 ft LCB = 42.377A ft-FP
 Displacement = 83.1 LTons GMT = 8.849 ft TCG = 0.000 ft-CL

DRAFT/GZ DATA

HEEL degrees	RIGHTING ARM ft	DRAFT AFT ft	DRAFT FWD ft	FLOODED WATER LTons
0.00	0.000	5.615	4.847	21.7
5.00S	0.518	5.621	4.810	21.6
7.00S	0.721	5.623	4.778	21.6
10.00S	0.993	5.612	4.708	21.6
15.00S	1.275	5.506	4.535	21.6
20.00S	1.368	5.305	4.294	21.7
22.00S	1.337	5.229	4.173	21.7
30.00S	0.892	4.970	3.621	21.6
35.00S	0.450	4.809	3.254	21.4
40.00S	-0.057	4.644	2.852	21.3

Note: Drafts are measured at A.P. and F.P along ship's centerline

GZ SUMMARY (Evaluated per IMO (SOLAS'90) Rules for Passenger Ships)

	Available	Required
Static Heel Angle	0.00 deg	7.00 deg
Angle at Maximum GZ	21.00S deg	
Maximum GZ	1.368 ft	0.740 ft
Range of Positive GZ	40.00 deg	15.00 deg
Gmt (upright damaged)	5.941 ft	
Righting Area (0.00-%.00)	20.277 ft-deg	2.820 ft-deg

**APPENDIX B
HYDROSTATICS AND
DAMAGE STABILITY
OUTPUT**

105' DINNER BOAT

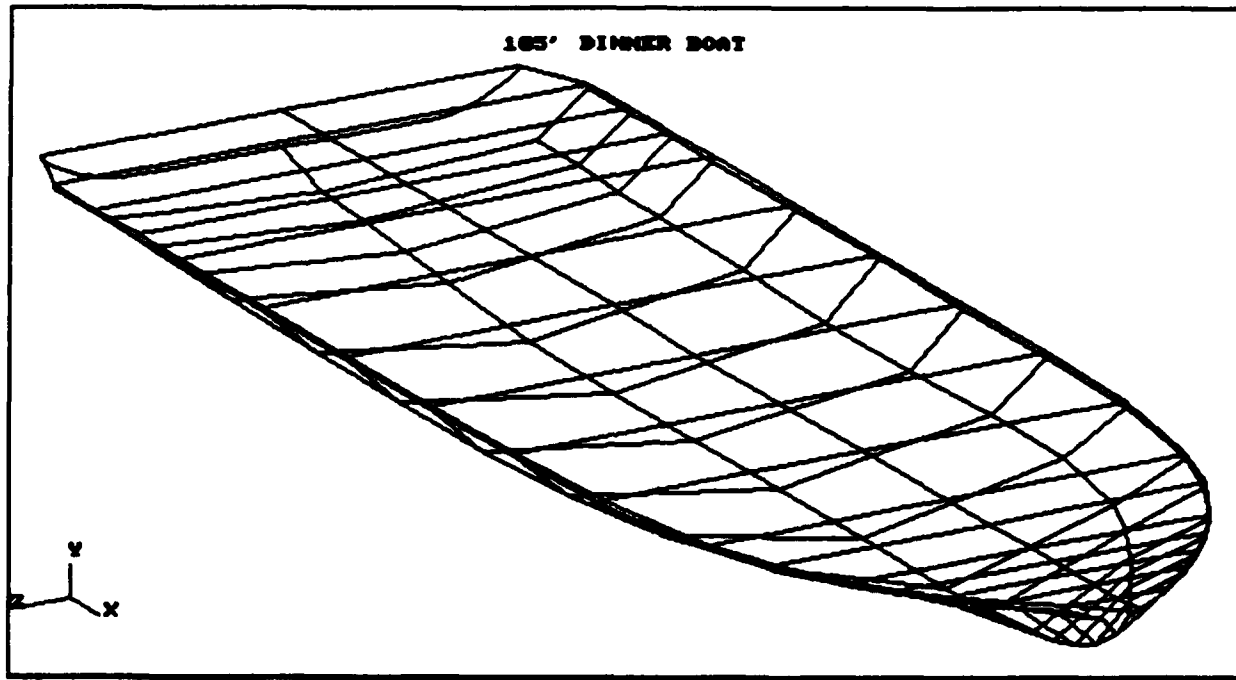

DAMAGE STABILITY SUMMARY
105' DINNER BOAT

CASE No.	FILE NAME	DAMAGED COMP. LISTING	---Intact Condition---			-----Equilibrium Condition After Damage-----					
			MIN.DRAFT (ft)	VCG (ft)	GMt (ft)	HEEL (deg)	MAX.GZ (ft)	RANGE (deg)	AREA (ft-deg)	DAM.GMt (ft)	SURVIVAL
1	DPRT001A	1	6.290	13.540	18.015	0.0	4.037	48.73	61.22	17.922	Yes
2	DPRT002A	1,2	6.290	13.540	18.015	0.0	3.959	47.26	60.88	18.220	Yes
3	DPRT003A	2	6.290	13.540	18.015	0.0	3.967	47.63	60.90	18.185	Yes
4	DPRT004A	3	6.290	13.540	18.015	0.0	3.738	46.40	57.91	17.484	Yes
5	DPRT005A	4	6.290	13.540	18.015	0.0	2.646	38.38	43.22	15.976	Yes
6	DPRT006A	5	6.290	13.540	18.015	0.0	3.778	46.61	58.12	17.176	Yes
7	DPRT007A	5,7	6.290	13.540	18.015	0.6P	3.531	44.79	52.78	----	Yes
8	DPRT008A	10	6.290	13.540	18.015	0.0	3.023	41.49	48.20	15.477	Yes
9	DPRT009A	11	6.290	13.540	18.015	0.0	3.454	44.96	53.56	15.907	Yes
10	DPRT010A	12	6.290	13.540	18.015	0.0	3.515	45.43	53.95	15.699	Yes

DAMAGE STABILITY SUMMARY
105' DINNER BOAT

C. No.	FILE NAME	DAMAGED COMP. LISTING	---Intact Condition---			-----Equilibrium Condition After Damage-----					
			MM.DRAFT (ft)	VCG (ft)	GMt (ft)	HEEL (deg)	MAX.GZ (ft)	RANGE (deg)	AREA (ft-deg)	DAM.GMt (ft)	SURVIVAL
1	RTRN001A	1	6.135	13.680	18.399	0.0	4.134	50.00	62.41	18.293	Yes
2	RTRN002A	1,2	6.135	13.680	18.399	0.0	4.112	48.08	62.67	18.609	Yes
3	RTRN003A	2	6.135	13.680	18.399	0.0	4.112	48.32	62.61	18.574	Yes
4	RTRN004A	3	6.135	13.680	18.399	0.0	3.889	47.12	59.73	17.855	Yes
5	RTRN005A	4	6.135	13.680	18.399	0.0	2.880	39.89	46.44	16.004	Yes
6	RTRN006A	5	6.135	13.680	18.399	0.0	3.889	47.17	59.46	17.487	Yes
7	RTRN007A	5,7	6.135	13.680	18.399	0.3s	3.634	45.60	55.21	----	Yes
8	RTRN008A	10	6.135	13.680	18.399	0.0	3.120	42.17	49.54	15.712	Yes
9	RTRN009A	11	6.135	13.680	18.399	0.0	3.537	45.47	54.64	16.183	Yes
10	RTRN010A	12	6.135	13.680	18.399	0.0	3.588	45.89	54.90	15.964	Yes

HYDROSTATIC TABLES
 105' DINNER BOAT

LOADED DRAFT (ft)	5.000	5.680	6.360	7.040	7.710	8.390	9.070	9.750
DISP. NLD. (LTons-SW)	168	223	280	341	403	469	538	609
DISP. TOTAL (LTons-SW)	169	224	282	343	405	471	540	612
DISP. TOTAL (LTons-FW)	165	218	275	334	395	460	527	597
LCB (ft-FP)	54.699A	55.814A	56.536A	56.959A	57.184A	57.262A	57.234A	57.145A
LCB (forebody) (ft-FP)	34.732A	34.401A	34.076A	33.768A	33.465A	33.127A	32.771A	32.415A
LCB (aftbody) (ft-FP)	71.748A	73.279A	74.359A	75.099A	75.628A	76.037A	76.360A	76.620A
LCB (ft-CL)	0.000	0.000	0.000	0.000	0.000	0.000	0.000	0.000
KB (ft)	3.578	4.010	4.423	4.826	5.218	5.614	6.012	6.409
BMT (ft)	35.293	30.162	26.870	24.508	22.907	21.780	20.991	19.710
KMT (ft)	38.872	34.171	31.293	29.334	28.125	27.394	27.003	26.119
BMI (ft)	295.313	246.385	220.400	193.550	175.586	162.869	152.276	139.961
KMI (ft)	298.891	250.395	224.823	198.376	180.803	168.484	158.288	146.371
(LTons)	6.5	6.8	7.3	7.6	7.9	8.2	8.6	8.8
(ft-LTons)	39	44	49	52	56	61	65	68
(LTons)	0.4	0.4	0.5	0.4	0.4	0.4	0.3	0.3
LCF (ft-FP)	58.947A	58.800A	59.123A	58.705A	58.101A	57.386A	56.721A	56.377A
W.P. AREA (ft ²)	2,714	2,869	3,048	3,177	3,314	3,463	3,612	3,704
WETTED SUR. (ft ²)	2,878	3,097	3,353	3,568	3,790	4,024	4,261	4,473
MAX. BEAM (ft)	32.639	33.541	34.443	35.346	36.234	37.136	38.038	38.613
LENGTH W.L. (ft)	101.534	104.050	105.000	105.000	105.000	105.000	105.000	105.000
Cb	0.3291	0.3842	0.4325	0.4749	0.5126	0.5480	0.5812	0.6125
Cb (forebody)	0.3032	0.3452	0.3827	0.4169	0.4485	0.4796	0.5100	0.5397
Cb (aftbody)	0.3551	0.4232	0.4822	0.5329	0.5767	0.6164	0.6524	0.6853
Cm	0.5268	0.5801	0.6249	0.6635	0.6972	0.7281	0.7563	0.7823
Cp	0.6248	0.6622	0.6921	0.7157	0.7352	0.7527	0.7685	0.7829
Cwp	0.7603	0.8037	0.8537	0.8900	0.9284	0.9701	1.0118	1.0376
Cit	0.6029	0.6832	0.7672	0.8506	0.9398	1.0395	1.1486	1.2218

Assumes: See Water at 35.0063 ft³/LT
 Fresh Water at 35.8814 ft³/LT
 Ship floating at even keel (no heel or trim)

DPR001A:
 105' DINNER BOAT

Damaged Compartments:
 FOREPEAK

	DISPLACEMENT LTons	DRAFT AFT ft	DRAFT FWD ft	TRIM ft	HEEL deg.	UPRIGHT GMT ft
INTACT	275.8	6.290	6.290	0.000	0.00	18.015
DAMAGED	276.6	6.263	6.347	0.085F	0.00	17.922

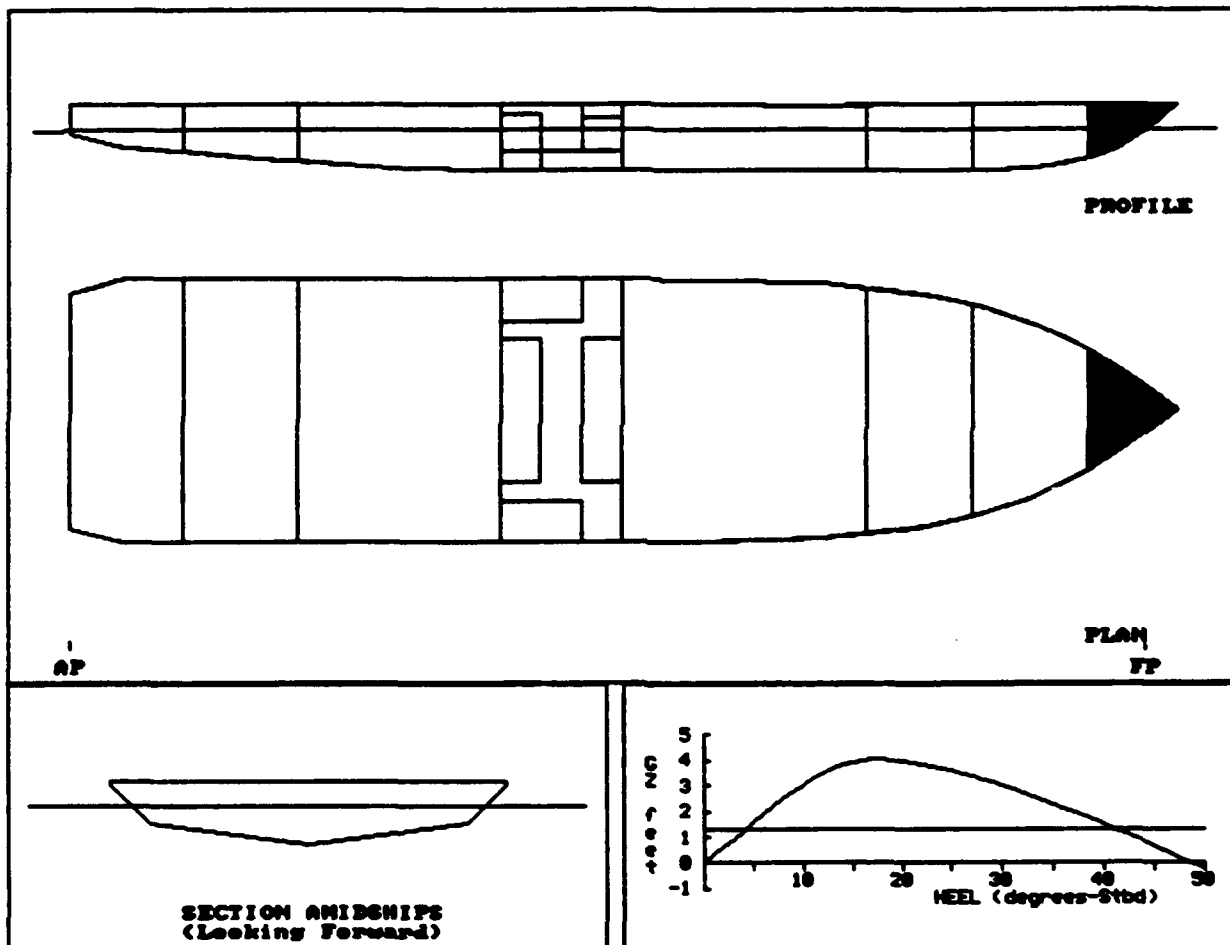

DFRT001A:
 105' DINNER BOAT

COMPARTMENT FLOODING SUMMARY

At 0.0o Heel	PERM.	FLOODED WTR LTons	% FULL (Damaged)	% FULL (Intact)	SP.VOL. ft3/LT	OUTFLOW LTons
FOREPEAK	0.95	0.8	FREE	0.0	----	----
Totals		0.8				

INTACT DATA

Draft at AP = 6.290 ft	KMt = 31.555 ft	LCG = 56.479A ft-FP
Draft at FP = 6.290 ft	VCG = 13.540 ft	LCB = 56.479A ft-FP
Displacement = 275.8 LTons	GMT = 18.015 ft	TCG = 0.000 ft-CL

DRAFT/GZ DATA

HEEL degrees	RIGHTING ARM ft	DRAFT AFT ft	DRAFT FWD ft	FLOODED WATER LTons
0.00	0.000	6.263	6.347	0.8
5.00S	1.571	6.220	6.282	0.8
7.00S	2.190	6.139	6.257	0.8
10.00S	3.041	5.961	6.166	0.8
15.00S	3.936	5.514	5.946	0.7
20.00S	3.972	5.106	5.758	0.6
30.00S	3.005	4.329	5.482	0.6
40.00S	1.495	3.413	5.337	0.9
50.00S	-0.221	2.190	5.264	1.3

Note: Drafts are measured at A.P. and F.P along ship's centerline

GZ SUMMARY (Evaluated per IMO (SOLAS'90) Rules for Passenger Ships)
 Available Required

Static Heel Angle	0.00 deg	7.00 deg
Angle at Maximum GZ	19.00S deg	1.400
Maximum GZ	4.037 ft	1.270 ft
Range of Positive GZ	48.73 deg	15.00 deg
Gmt (upright damaged)	17.922 ft	
Righting Area (0.00-%.00)	61.220 ft-deg	2.820 ft-deg

DPRT002A:
 105' DINNER BOAT

Imaged Compartments:

FOREPEAK VOID

	DISPLACEMENT LTons	DRAFT AFT ft	DRAFT FWD ft	TRIM ft	HEEL deg.	UPRIGHT GMT ft
INTACT	275.8	6.290	6.290	0.000	0.00	18.015
DAMAGED	290.8	5.915	7.153	1.238F	0.00	18.220

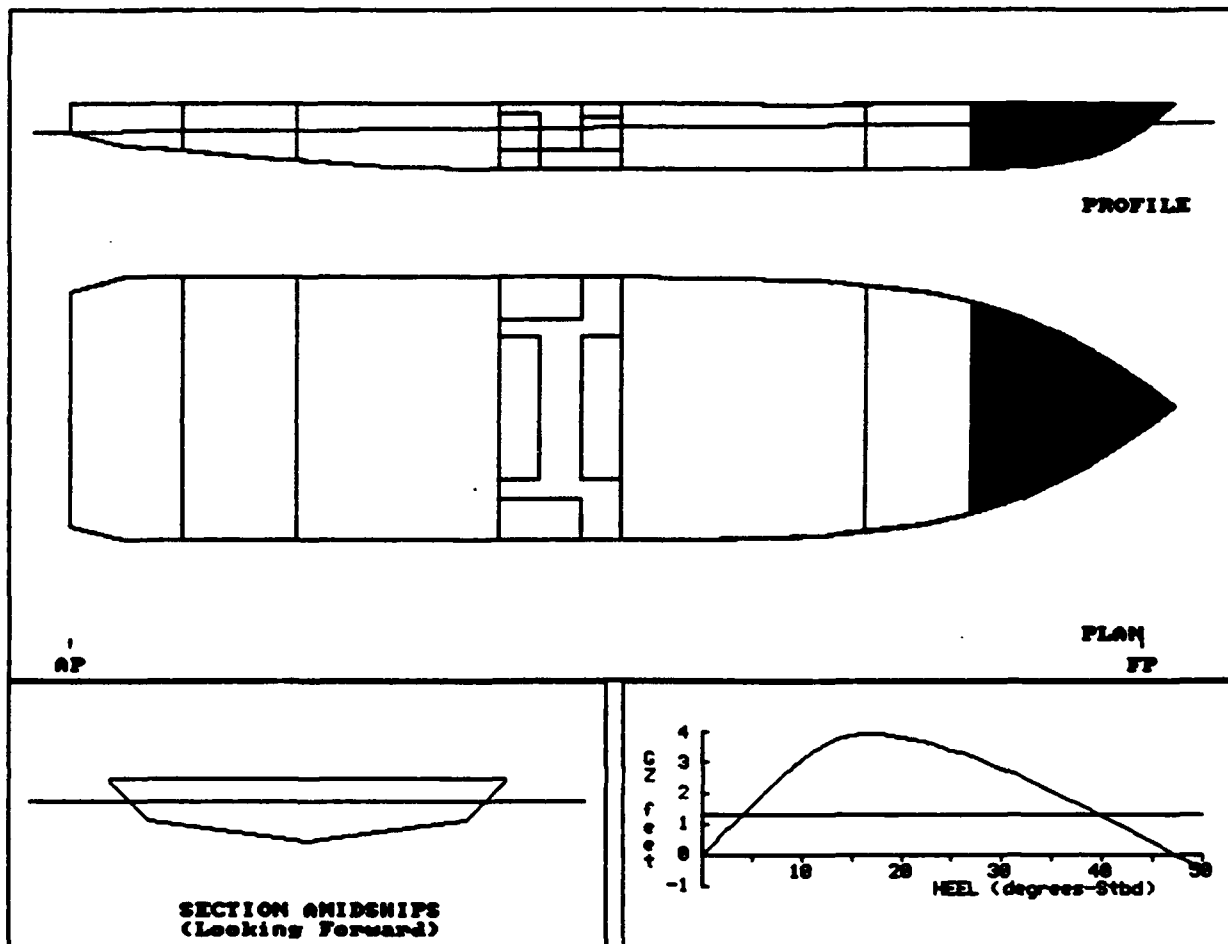

DPRT002A:
 105' DINNER BOAT

COMPARTMENT FLOODING SUMMARY

At 0.0o Heel	PERM.	FLOODED WTR LTons	% FULL (Damaged)	% FULL (Intact)	SP.VOL. ft3/LT	OUTFLOW LTons
FOREPEAK	0.95	1.3	FREE	0.0	----	----
VOID	0.95	13.7	FREE	0.0	----	----
Totals		15.0				

INTACT DATA

Draft at AP = 6.290 ft Kmt = 31.555 ft LCG = 56.479A ft-FP
 Draft at FP = 6.290 ft VCG = 13.540 ft LCB = 56.479A ft-FP
 Displacement = 275.8 LTons Gmt = 18.015 ft TCG = 0.000 ft-CL

DRAFT/GZ DATA

HEEL degrees	RIGHTING ARM ft	DRAFT AFT ft	DRAFT FWD ft	FLOODED WATER LTons
0.00	0.000	5.915	7.153	15.0
5.00S	1.596	5.853	7.102	15.0
7.00S	2.220	5.776	7.066	15.1
10.00S	3.093	5.575	7.003	15.3
15.00S	3.898	5.032	7.003	16.5
20.00S	3.854	4.436	7.197	18.4
30.00S	2.795	3.170	7.871	21.4
40.00S	1.247	1.588	8.959	23.7
50.00S	-0.477	-0.548	10.560	25.4

Note: Drafts are measured at A.P. and F.P along ship's centerline

GZ SUMMARY (Evaluated per IMO (SOLAS'90) Rules for Passenger Ships)
 Available Required

Static Heel Angle	0.00 deg	7.00 deg
Angle at Maximum GZ	18.00S deg	1.400
Maximum GZ	3.959 ft	1.270 ft
Range of Positive GZ	47.26 deg	15.00 deg
Gmt (upright damaged)	18.220 ft	
Righting Area (0.00-7.00)	60.878 ft-deg	2.820 ft-deg

DPRT003A:
 105' DINNER BOAT

Imaged Compartments:
 VOID

	DISPLACEMENT Ltons	DRAFT AFT ft	DRAFT FWD ft	TRIM ft	HEEL deg.	UPRIGHT GMT ft
INTACT	275.8	6.290	6.290	0.000	0.00	18.015
DAMAGED	289.1	5.964	7.049	1.086F	0.00	18.185

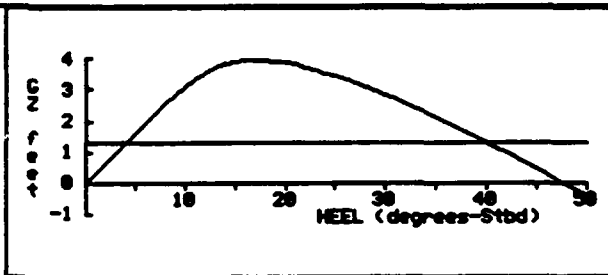
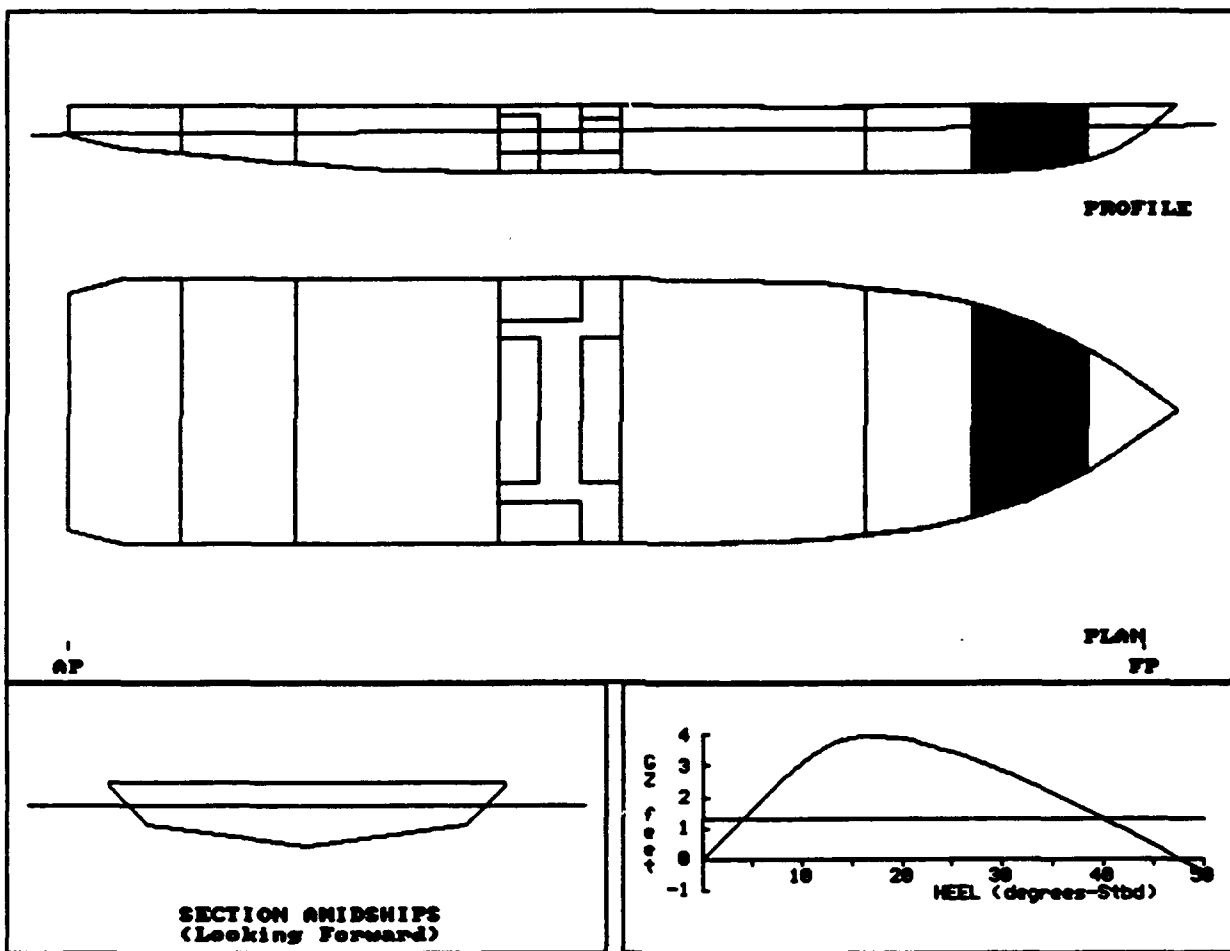

DFRTO03A:
 105' DINNER BOAT

COMPARTMENT FLOODING SUMMARY

At 0.0o Heel	PERM.	FLOODED WTR LTons	% FULL (Damaged)	% FULL (Intact)	SP.VOL. ft3/LT	OUTFLOW LTons
VOID	0.95	13.3	FREE	0.0	----	----
Totals		13.3				

INTACT DATA

Draft at AP = 6.290 ft	Kmt = 31.555 ft	LCG = 56.479A ft-FP
Draft at FP = 6.290 ft	VCG = 13.540 ft	LCB = 56.479A ft-FP
Displacement = 275.8 LTons	Gmt = 18.015 ft	TCG = 0.000 ft-CL

DRAFT/GZ DATA

HEEL degrees	RIGHTING ARM ft	DRAFT AFT ft	DRAFT FWD ft	FLOODED WATER LTons
0.00	0.000	5.964	7.049	13.3
5.00S	1.592	5.904	6.998	13.3
7.00S	2.215	5.828	6.963	13.4
10.00S	3.086	5.626	6.902	13.6
15.00S	3.902	5.097	6.870	14.7
20.00S	3.867	4.536	6.995	16.1
30.00S	2.833	3.414	7.397	17.7
40.00S	1.302	2.070	8.058	18.7
50.00S	-0.410	0.292	9.035	19.5

Note: Drafts are measured at A.P. and F.P along ship's centerline

GZ SUMMARY (Evaluated per IMO (SOLAS'90) Rules for Passenger Ships)
 Available Required

Static Heel Angle	0.00 deg	7.00 deg
Angle at Maximum GZ	18.00S deg	1.400
Maximum GZ	3.967 ft	1.270 ft
Range of Positive GZ	47.63 deg	15.00 deg
Gmt (upright damaged)	18.185 ft	
Righting Area (0.00-1.00)	60.905 ft-deg	2.820 ft-deg

DPRT004A:
 105' DINNER BOAT

Damaged Compartments:
 DRY STORES

	DISPLACEMENT LTons	DRAFT AFT ft	DRAFT FWD ft	TRIM ft	HEEL deg.	UPRIGHT Gmt ft
INTACT	275.8	6.290	6.290	0.000	0.00	18.015
DAMAGED	304.1	5.829	7.591	1.763F	0.00	17.484

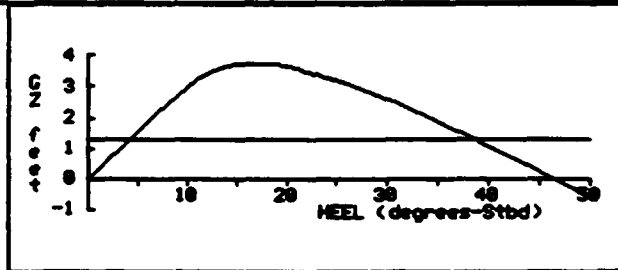
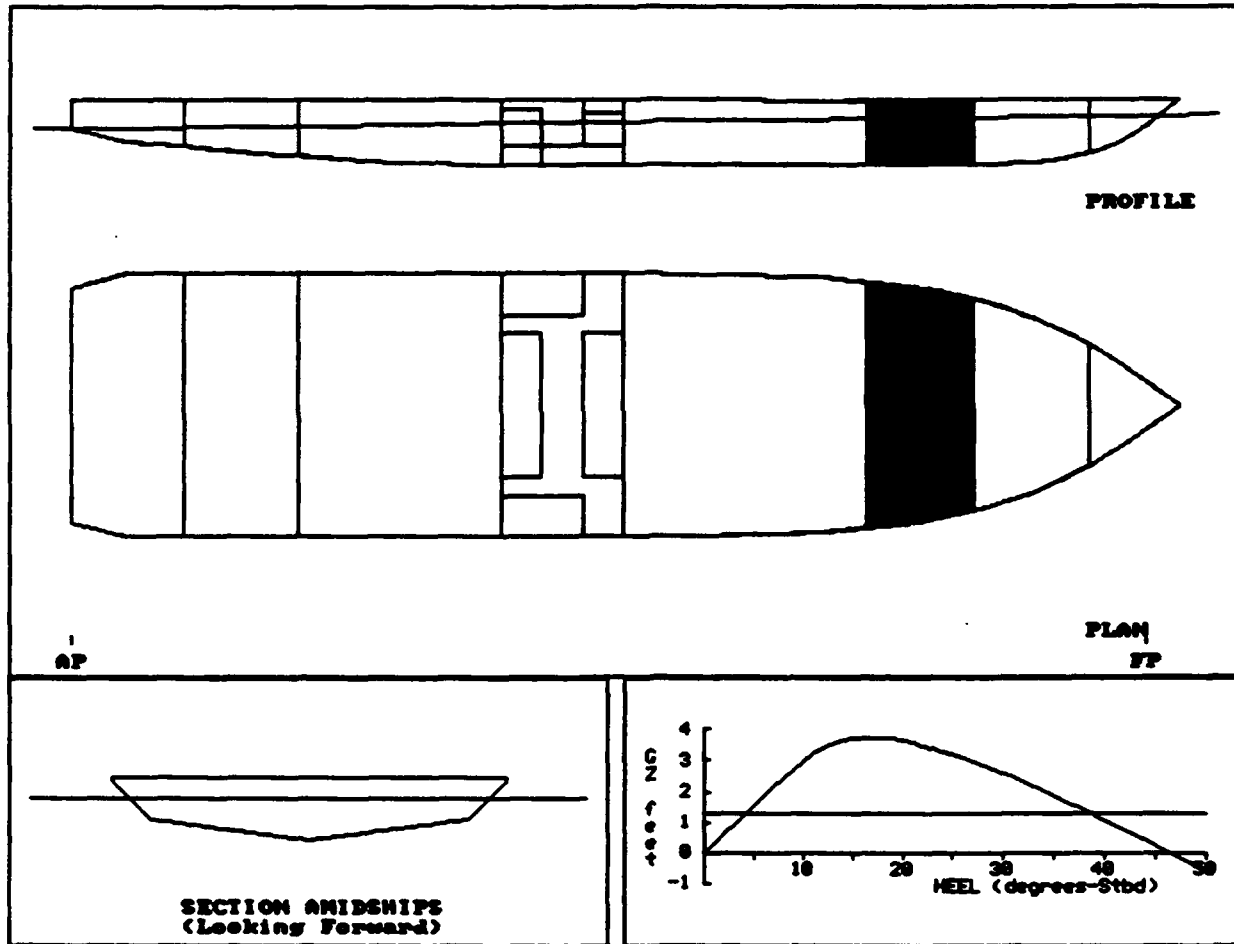

DPRT004A:
 105' DINNER BOAT

COMPARTMENT FLOODING SUMMARY

At 0.0o Heel	PERM.	FLOODED WTR LTons	% FULL (Damaged)	% FULL (Intact)	SP.VOL. ft3/LT	OUTFLOW LTons
DRY STORES	0.95	28.3	FREE	0.0	----	----
Totals		28.3				

INTACT DATA

Draft at AP = 6.290 ft	KMt = 31.555 ft	LCG = 56.479A ft-FP
Draft at FP = 6.290 ft	VCG = 13.540 ft	LCB = 56.479A ft-FP
Displacement = 275.8 LTons	Gmt = 18.015 ft	TCG = 0.000 ft-CL

DRAFT/GZ DATA

HEEL degrees	RIGHTING ARM ft	DRAFT AFT ft	DRAFT FWD ft	FLOODED WATER LTons
0.00	0.000	5.829	7.591	28.3
5.00S	1.533	5.757	7.552	28.5
7.00S	2.131	5.677	7.522	28.8
10.00S	2.974	5.482	7.466	29.4
15.00S	3.694	4.943	7.538	30.1
20.00S	3.630	4.397	7.721	30.5
30.00S	2.583	3.290	8.281	30.8
40.00S	1.071	1.978	9.124	31.1
50.00S	-0.611	0.213	10.385	31.2

Note: Drafts are measured at A.P. and F.P along ship's centerline

GZ SUMMARY (Evaluated per IMO (SOLAS'90) Rules for Passenger Ships)

	Available	Required
Static Heel Angle	0.00 deg	7.00 deg
Angle at Maximum GZ	18.00S deg	1.400
Maximum GZ	3.738 ft	1.270 ft
Range of Positive GZ	46.40 deg	15.00 deg
Gmt (upright damaged)	17.484 ft	
Righting Area (0.00-7.00)	57.906 ft-deg	2.820 ft-deg

DPR005A:
 105' DINNER BOAT

Damaged Compartments:
 CATERER AREA

	DISPLACEMENT LTons	DRAFT AFT ft	DRAFT FWD ft	TRIM ft	HEEL deg.	UPRIGHT GMT ft
INTACT	275.8	6.290	6.290	0.000	0.00	18.015
DAMAGED	393.4	6.048	9.398	3.350F	0.00	15.976

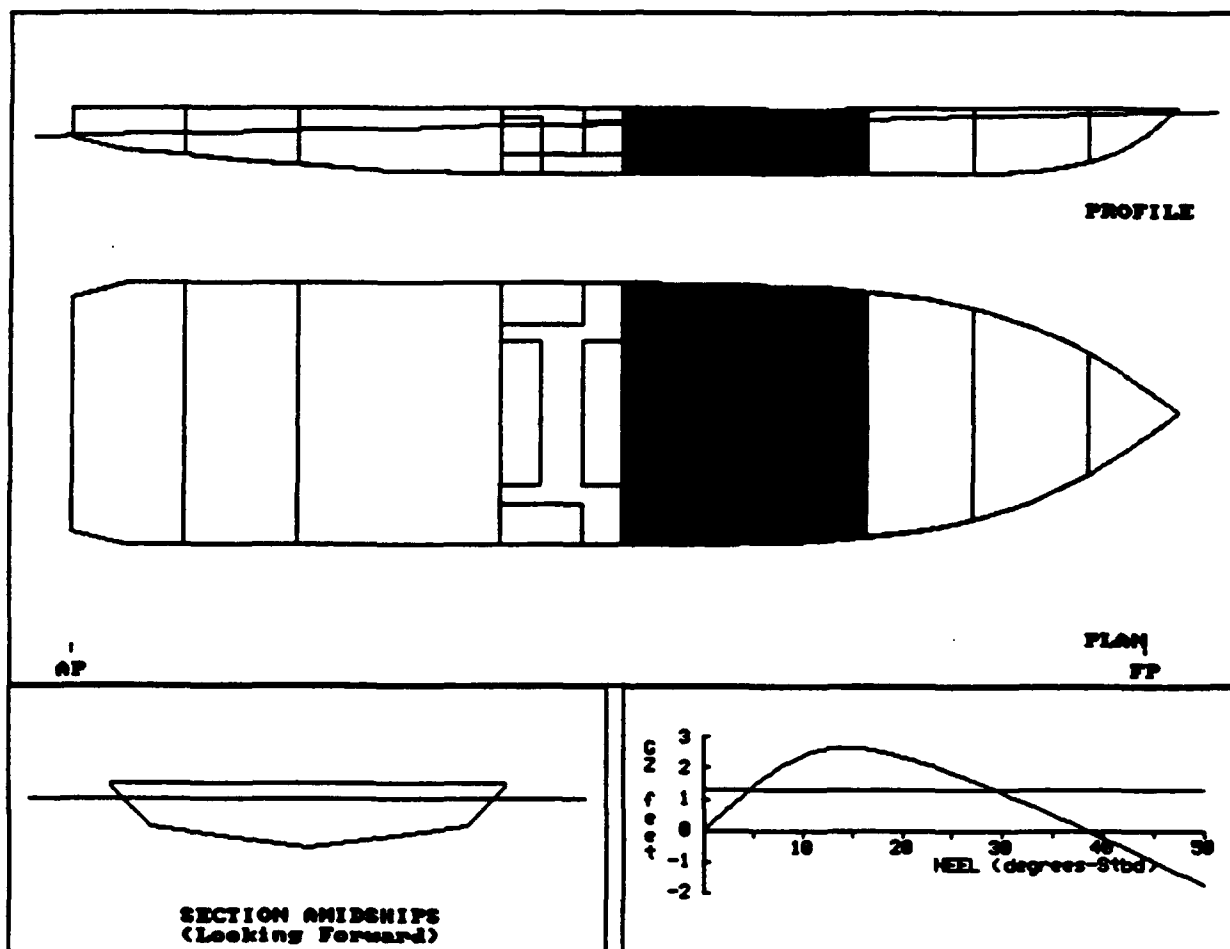

DPRTO05A:
 105' DINNER BOAT

COMPARTMENT FLOODING SUMMARY

At 0.0o Heel	PERM.	FLOODED WTR LTons	% FULL (Damaged)	% FULL (Intact)	SP.VOL. ft3/LT	OUTFLOW LTons
CATERER AREA	0.95	117.6	FREE	0.0	----	----
Totals		117.6				

INTACT DATA

Draft at AP = 6.290 ft	KMt = 31.555 ft	LCG = 56.479A ft-FP
Draft at FP = 6.290 ft	VCG = 13.540 ft	LCB = 56.479A ft-FP
Displacement = 275.8 LTons	GMT = 18.015 ft	TCG = 0.000 ft-CL

DRAFT/GZ DATA

HEEL degrees	RIGHTING ARM ft	DRAFT AFT ft	DRAFT FWD ft	FLOODED WATER LTons
0.00	0.000	6.048	9.398	117.6
5.00S	1.383	5.984	9.347	117.6
7.00S	1.854	5.897	9.378	117.7
10.00S	2.387	5.676	9.558	116.5
15.00S	2.643	5.197	10.186	114.8
20.00S	2.359	4.726	11.007	113.6
30.00S	1.197	3.709	13.113	112.5
40.00S	-0.241	2.462	15.940	112.1
50.00S	-1.749	0.774	19.915	112.0

Note: Drafts are measured at A.P. and F.P along ship's centerline

GZ SUMMARY (Evaluated per IMO (SOLAS'90) Rules for Passenger Ships)

	Available	Required
Static Heel Angle	0.00 deg	7.00 deg
Angle at Maximum GZ	15.00S deg	
Maximum GZ	2.646 ft	1.270 1.400 ft
Range of Positive GZ	38.38 deg	15.00 deg
Gmt (upright damaged)	15.976 ft	
Righting Area (0.00-7.00)	43.222 ft-deg	2.820 ft-deg

DPRT006A:
 105' DINNER BOAT

Imaged Compartments:
 TANKS

	DISPLACEMENT LTons	DRAFT AFT ft	DRAFT FWD ft	TRIM ft	HEEL deg.	UPRIGHT GMT ft
INTACT	275.8	6.290	6.290	0.000	0.00	18.015
DAMAGED	300.3	6.513	6.641	0.128F	0.00	17.176

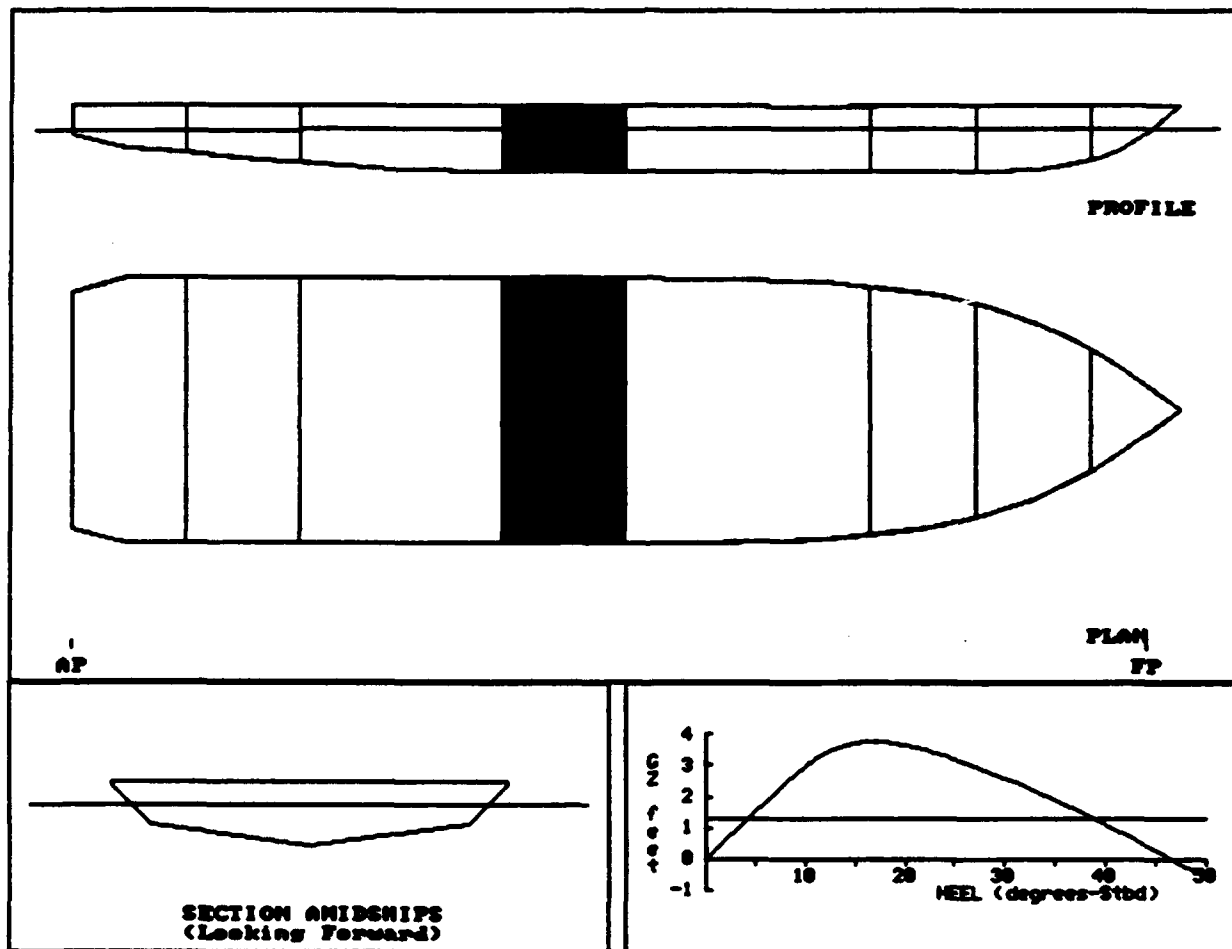

DPRT006A:
 105' DINNER BOAT

COMPARTMENT FLOODING SUMMARY

At 0.0o Heel	PERM.	FLOODED WTR LTons	% FULL (Damaged)	% FULL (Intact)	SP.VOL. ft3/LT	OUTFLOW LTons
TANKS	0.95	24.5	FREE	0.0	----	----
Totals		24.5				

INTACT DATA

Draft at AP = 6.290 ft KMt = 31.555 ft LCG = 56.479A ft-FP
 Draft at FP = 6.290 ft VCG = 13.540 ft LCB = 56.479A ft-FP
 Displacement = 275.8 LTons GMT = 18.015 ft TCG = 0.000 ft-CL

DRAFT/GZ DATA

HEEL degrees	RIGHTING ARM ft	DRAFT AFT ft	DRAFT FWD ft	FLOODED WATER LTons
0.00	0.000	6.513	6.641	24.5
5.00S	1.510	6.472	6.572	24.4
7.00S	2.118	6.414	6.523	24.3
10.00S	2.976	6.239	6.441	24.0
15.00S	3.733	5.878	6.252	23.6
20.00S	3.658	5.600	6.118	23.9
30.00S	2.606	5.104	5.955	24.0
40.00S	1.101	4.578	5.854	24.0
50.00S	-0.575	3.905	5.817	23.9

Note: Drafts are measured at A.P. and F.P along ship's centerline

GZ SUMMARY (Evaluated per IMO (SOLAS'90) Rules for Passenger Ships)
 Available Required

Static Heel Angle	0.00 deg	7.00 deg
Angle at Maximum GZ	18.00S deg	1.400
Maximum GZ	3.778 ft	1.270 ft
Range of Positive GZ	46.61 deg	15.00 deg
Gmt (upright damaged)	17.176 ft	
Righting Area (0.00- $\frac{1}{2}$.00)	58.117 ft-deg	2.820 ft-deg

DPRT007A:
 105' DINNER BOAT

Damaged Compartments:

TANKS FOTANK STBD

	DISPLACEMENT LTONS	DRAFT AFT ft	DRAFT FWD ft	TRIM ft	HEEL deg.	UPRIGHT GMT ft
INTACT	275.8	6.290	6.290	0.000	0.00	18.015
DAMAGED	296.9	6.469	6.596	0.127F	0.63P	16.599

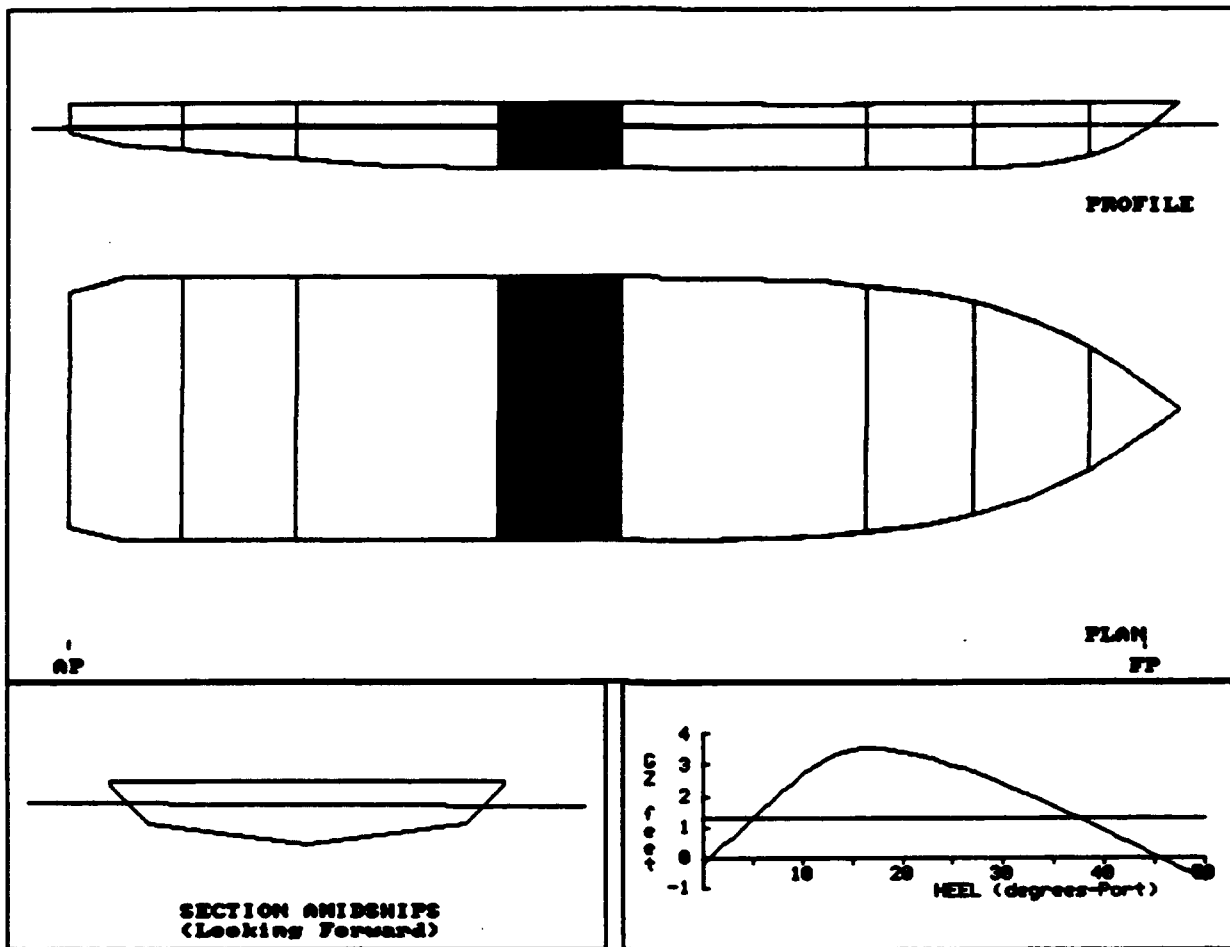

DPRT007A:
 105' DINNER BOAT

COMPARTMENT FLOODING SUMMARY

At 0.60P Heel	PERM.	FLOODED WTR LTons	% FULL (Damaged)	% FULL (Intact)	SP.VOL. ft3/LT	OUTFLOW LTons
TANKS	0.95	24.3	FREE	0.0	----	----
FOTANK STBD	0.95	1.8	FREE	100.0	40.6000	5.1
Totals		26.2				5.1

INTACT DATA

Draft at AP = 6.290 ft Kmt = 31.555 ft LCG = 56.479A ft-FP
 Draft at FP = 6.290 ft VCG = 13.540 ft LCB = 56.479A ft-FP
 Displacement = 275.8 LTons Gmt = 18.015 ft TCG = 0.000 ft-CL

DRAFT/GZ DATA

HEEL degrees	RIGHTING ARM ft	DRAFT AFT ft	DRAFT FWD ft	FLOODED WATER LTons
0.00	-0.183	6.476	6.604	26.3
5.00P	1.279	6.410	6.538	25.1
7.00P	1.868	6.344	6.488	24.6
10.00P	2.693	6.171	6.385	23.8
15.00P	3.475	5.783	6.188	23.2
20.00P	3.421	5.472	6.046	23.5
30.00P	2.388	4.906	5.860	23.7
40.00P	0.893	4.292	5.738	23.6
50.00P	-0.769	3.503	5.667	23.5

Note: Drafts are measured at A.P. and F.P along ship's centerline

GZ SUMMARY (Evaluated per IMO (SOLAS'90) Rules for Passenger Ships)
 Available Required

Static Heel Angle	0.63P deg	7.00 deg
Angle at Maximum GZ	18.00P deg	1.400
Maximum GZ	3.531 ft	1.270 ft
Range of Positive GZ	44.79 deg	15.00 deg
Righting Area (0.63-1.00)	52.781 ft-deg	2.820 ft-deg

DPRT008A:
105' DINNER BOAT

Imaged Compartments:
ENGINE ROOM

	DISPLACEMENT LTons	DRAFT AFT ft	DRAFT FWD ft	TRIM ft	HEEL deg.	UPRIGHT GMT ft
INTACT	275.8	6.290	6.290	0.000	0.00	18.015
DAMAGED	352.4	7.915	6.157	1.758A	0.00	15.477

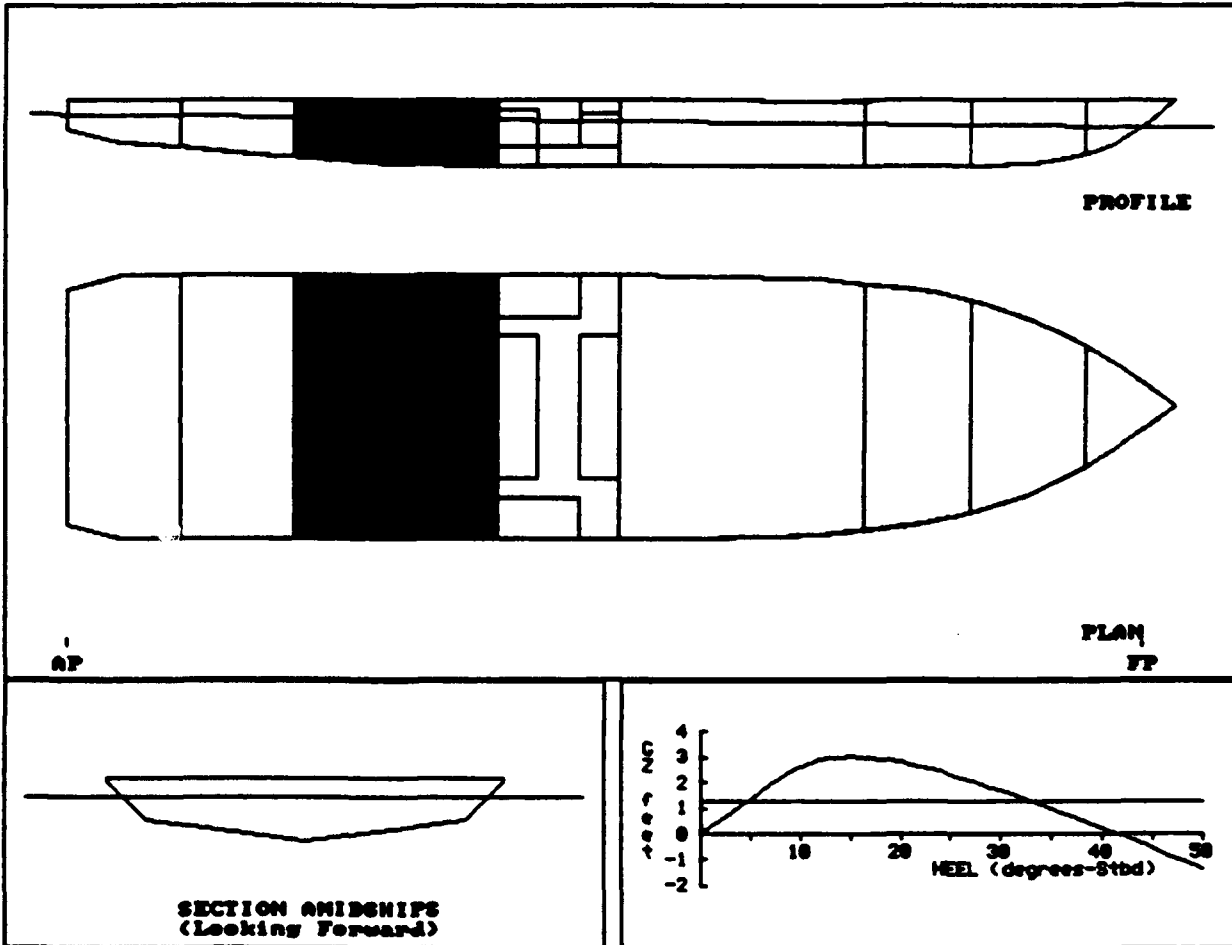

DPRT008A:
 105' DINNER BOAT

COMPARTMENT FLOODING SUMMARY

At 0.0o Heel	PERM.	FLOODED WTR LTons	% FULL (Damaged)	% FULL (Intact)	SP.VOL. ft3/LT	OUTFLOW LTons
ENGINE ROOM	0.85	76.6	FREE	0.0	----	----
Totals		76.6				

INTACT DATA

Draft at AP = 6.290 ft	Kmt = 31.555 ft	LCG = 56.479A ft-FP
Draft at FP = 6.290 ft	VCG = 13.540 ft	LCB = 56.479A ft-FP
Displacement = 275.8 LTons	Gmt = 18.015 ft	TCG = 0.000 ft-CL

DRAFT/GZ DATA

HEEL degrees	RIGHTING ARM ft	DRAFT AFT ft	DRAFT FWD ft	FLOODED WATER LTons
0.00	0.000	7.915	6.157	76.6
5.00S	1.363	7.863	6.100	76.5
7.00S	1.919	7.814	6.046	76.4
10.00S	2.628	7.812	5.874	76.5
15.00S	3.023	8.044	5.492	75.9
20.00S	2.802	8.371	5.158	75.4
30.00S	1.686	9.290	4.473	75.0
40.00S	0.230	10.521	3.729	74.7
50.00S	-1.332	12.181	2.867	74.5

Note: Drafts are measured at A.P. and F.P along ship's centerline

GZ SUMMARY (Evaluated per IMO (SOLAS'90) Rules for Passenger Ships)

	Available	Required
Static Heel Angle	0.00 deg	7.00 deg
Angle at Maximum GZ	16.00S deg	1.400
Maximum GZ	3.023 ft	1.270 ft
Range of Positive GZ	41.49 deg	15.00 deg
Gmt (upright damaged)	15.477 ft	
Righting Area (0.00-7.00)	48.196 ft-deg	2.820 ft-deg

DPRT009A:
 105' DINNER BOAT

Damaged Compartments:
 EXH SILENCER

	DISPLACEMENT LTons	DRAFT AFT ft	DRAFT FWD ft	TRIM ft	HEEL deg.	UPRIGHT GMT ft
INTACT	275.8	6.290	6.290	0.000	0.00	18.015
DAMAGED	311.0	7.461	5.682	1.779A	0.00	15.907

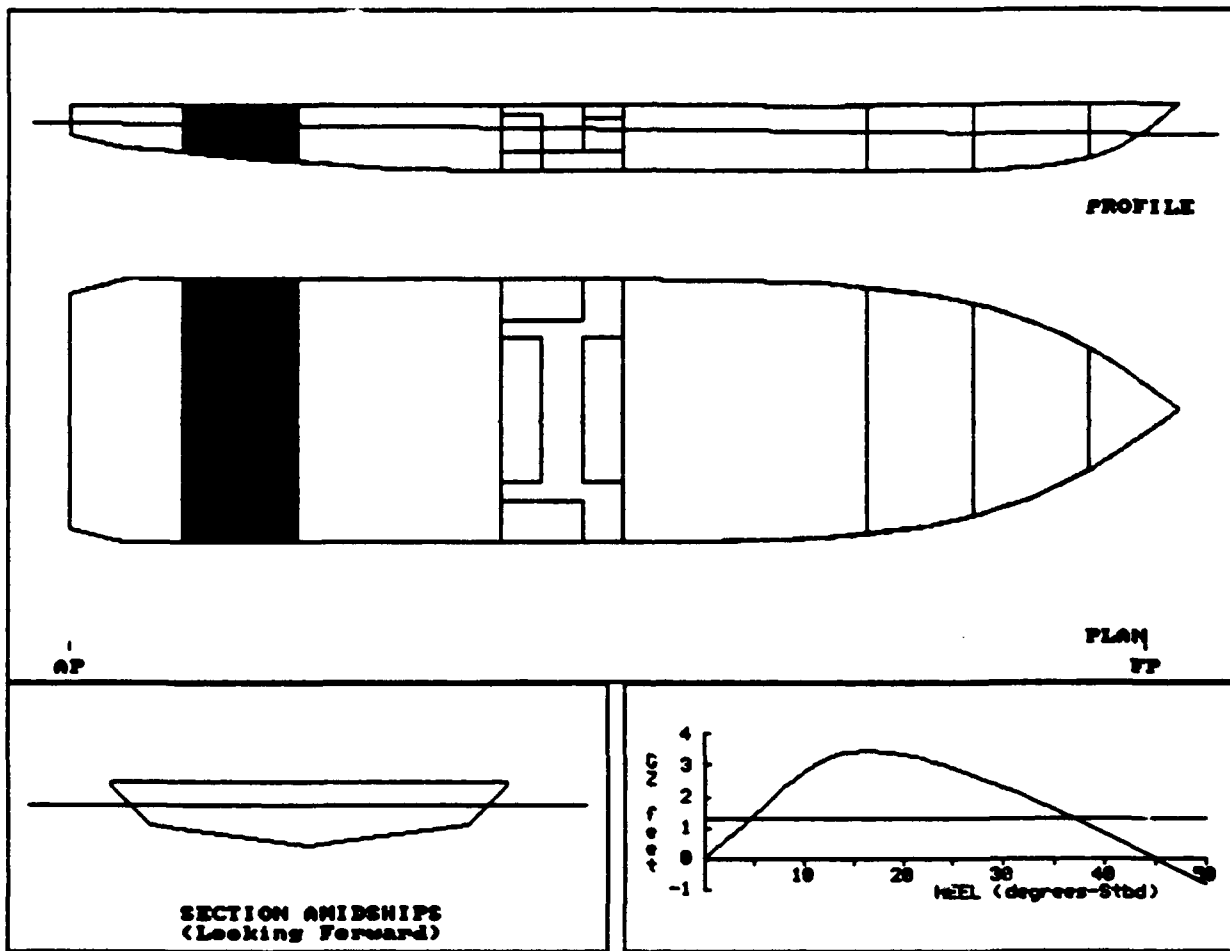

DPRT009A:
 105' DINNER BOAT

COMPARTMENT FLOODING SUMMARY

At 0.0o Heel	PERM.	FLOODED WTR LTons	% FULL (Damaged)	% FULL (Intact)	SP.VOL. ft3/LT	OUTFLOW LTons
EXH SILENCER	0.95	35.2	FREE	0.0	----	----
Totals		35.2				

INTACT DATA

Draft at AP = 6.290 ft	KMt = 31.555 ft	LCG = 56.479A ft-FP
Draft at FP = 6.290 ft	VCG = 13.540 ft	LCB = 56.479A ft-FP
Displacement = 275.8 LTons	GMT = 18.015 ft	TCG = 0.000 ft-CL

DRAFT/GZ DATA

HEEL degrees	RIGHTING ARM ft	DRAFT AFT ft	DRAFT FWD ft	FLOODED WATER LTons
0.00	0.000	7.461	5.682	35.2
5.00S	1.398	7.414	5.626	35.3
7.00S	1.967	7.365	5.572	35.3
10.00S	2.787	7.279	5.434	35.2
15.00S	3.429	7.264	5.036	35.2
20.00S	3.330	7.376	4.623	35.4
30.00S	2.285	7.798	3.793	35.9
40.00S	0.805	8.433	2.868	36.2
50.00S	-0.832	9.307	1.745	36.5

Note: Drafts are measured at A.P. and F.P along ship's centerline

GZ SUMMARY (Evaluated per IMO (SOLAS'90) Rules for Passenger Ships)

	Available	Required
Static Heel Angle	0.00 deg	7.00 deg
Angle at Maximum GZ	17.00S deg	1.400
Maximum GZ	3.454 ft	1.270 ft
Range of Positive GZ	44.96 deg	15.00 deg
Gmt (upright damaged)	15.907 ft	
Righting Area (0.00-7.00)	53.560 ft-deg	2.820 ft-deg

DPRT010A:
105' DINNER BOAT

Damaged Compartments:
 STEERING ROM

	DISPLACEMENT LTons	DRAFT AFT ft	DRAFT FWD ft	TRIM ft	HEEL deg.	UPRIGHT GMT ft
INTACT	275.8	6.290	6.290	0.000	0.00	18.015
DAMAGED	298.9	7.245	5.647	1.598A	0.00	15.699

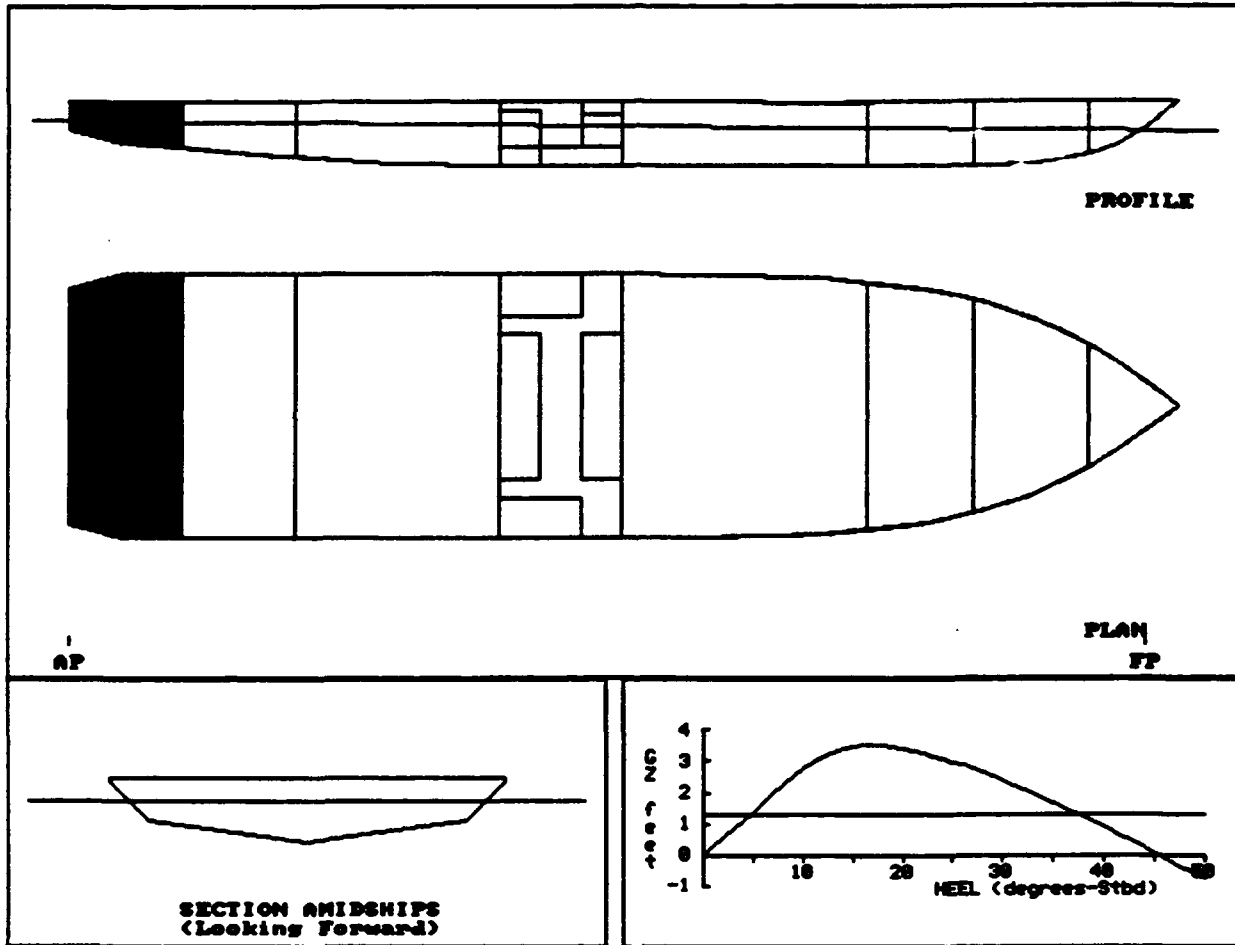

DPRT010A:
 105' DINNER BOAT

COMPARTMENT FLOODING SUMMARY

At 0.0o Heel	PERM.	FLOODED WTR LTons	% FULL (Damaged)	% FULL (Intact)	SP.VOL. ft3/LT	OUTFLOW LTons
STEERING ROM	0.95	23.1	FREE	0.0	----	----
Totals		23.1				

INTACT DATA

Draft at AP = 6.290 ft	KMT = 31.555 ft	LCG = 56.479A ft-FP
Draft at FP = 6.290 ft	VCG = 13.540 ft	LCB = 56.479A ft-FP
Displacement = 275.8 LTons	GMT = 18.015 ft	TCG = 0.000 ft-CL

DRAFT/GZ DATA

HEEL degrees	RIGHTING ARM ft	DRAFT AFT ft	DRAFT FWD ft	FLOODED WATER LTons
0.00	0.000	7.245	5.647	23.1
5.00S	1.380	7.205	5.586	23.3
7.00S	1.942	7.165	5.527	23.5
10.00S	2.770	7.081	5.382	24.0
15.00S	3.473	7.040	4.960	25.0
20.00S	3.407	7.145	4.500	26.0
30.00S	2.377	7.567	3.563	27.4
40.00S	0.891	8.202	2.510	28.4
50.00S	-0.763	9.118	1.171	29.1

Note: Drafts are measured at A.P. and F.P along ship's centerline

GZ SUMMARY (Evaluated per IMO (SOLAS'90) Rules for Passenger Ships)

	Available	Required
Static Heel Angle	0.00 deg	7.00 deg
Angle at Maximum GZ	18.00S deg	1.400
Maximum GZ	3.515 ft	1.270 ft
Range of Positive GZ	45.43 deg	15.00 deg
Gmt (upright damaged)	15.699 ft	
Righting Area (0.00-%.00)	53.946 ft-deg	2.820 ft-deg

RTRN001A:
 105' DINNER BOAT

Imaged Compartments:
 FOREPEAK

	DISPLACEMENT LTons	DRAFT AFT ft	DRAFT FWD ft	TRIM ft	HEEL deg.	UPRIGHT GMT ft
INTACT	264.8	6.350	5.920	0.430A	0.00	18.399
DAMAGED	265.4	6.328	5.967	0.361A	0.00	18.293

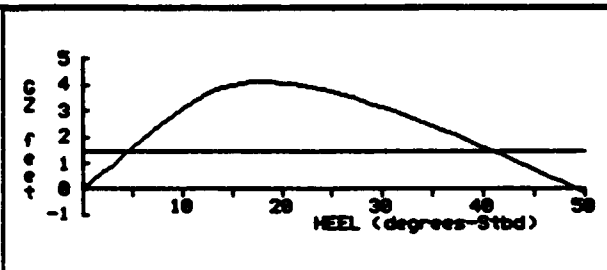
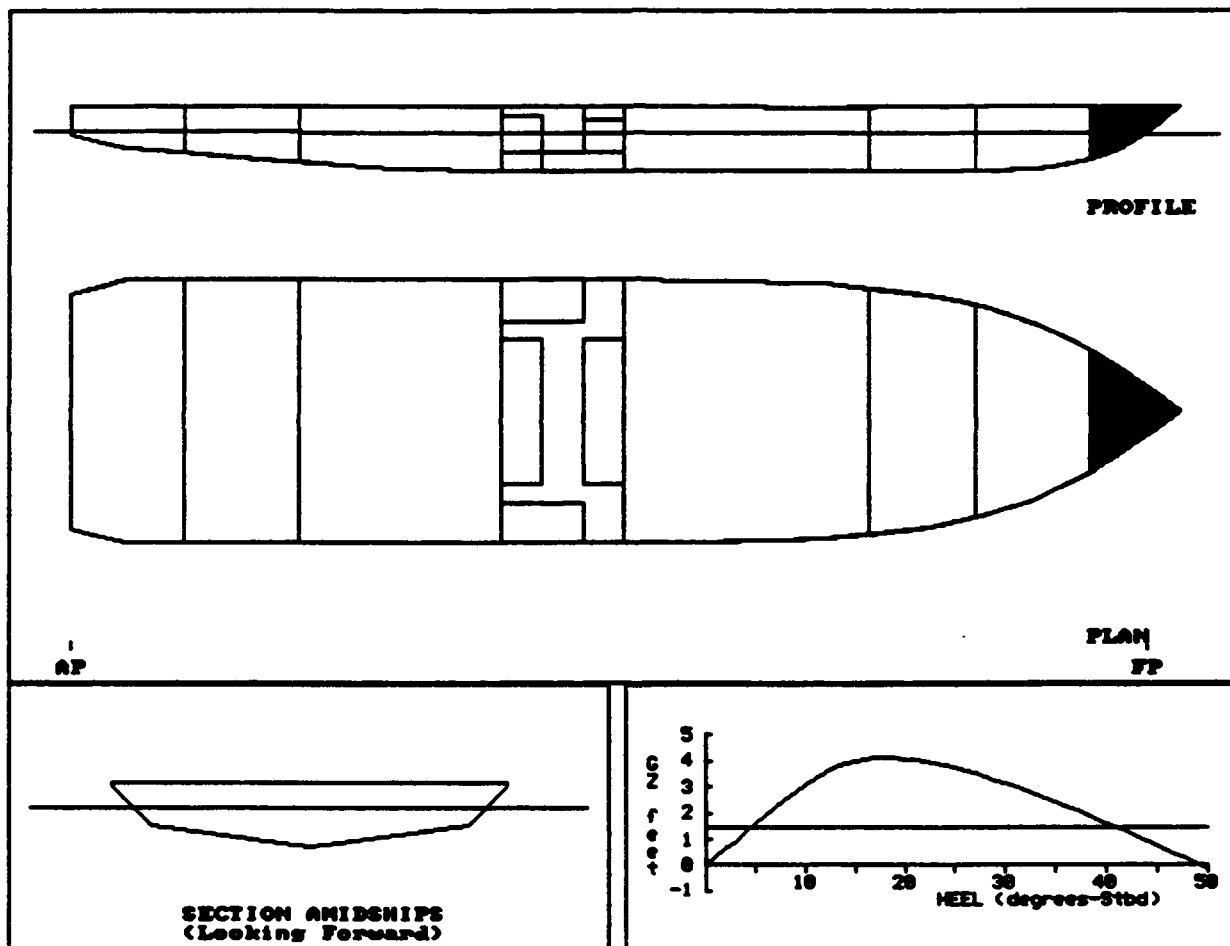

RTRN001A:
 105' DINNER BOAT

COMPARTMENT FLOODING SUMMARY

At 0.0o Heel	PERM.	FLOODED WTR LTons	% FULL (Damaged)	% FULL (Intact)	SP.VOL. ft3/LT	OUTFLOW LTons
FOREPEAK	0.95	0.7	FREE	0.0	----	----
Totals		0.7				

INTACT DATA

Draft at AP	= 6.350 ft	KMT	= 32.079 ft	LCG	= 57.266A ft-FP
Draft at FP	= 5.920 ft	VCG	= 13.680 ft	LCB	= 57.305A ft-FP
Displacement	= 264.8 LTons	GMT	= 18.399 ft	TCG	= 0.000 ft-CL

DRAFT/GZ DATA

HEEL degrees	RIGHTING ARM ft	DRAFT AFT ft	DRAFT FWD ft	FLOODED WATER LTons
0.00	0.000	6.328	5.967	0.7
5.00S	1.603	6.274	5.917	0.6
7.00S	2.230	6.207	5.875	0.6
10.00S	3.074	6.027	5.781	0.6
15.00S	4.006	5.575	5.521	0.5
20.00S	4.084	5.167	5.260	0.4
30.00S	3.139	4.409	4.784	0.3
40.00S	1.616	3.515	4.390	0.4
50.00S	-0.129	2.340	3.976	0.7

Note: Drafts are measured at A.P. and F.P along ship's centerline

GZ SUMMARY (Evaluated per IMO (SOLAS'90) Rules for Passenger Ships)

	Available	Required
Static Heel Angle	0.00 deg	7.00 deg
Angle at Maximum GZ	19.00S deg	
Maximum GZ	4.134 ft	1.450 ft
Range of Positive GZ	50.00 deg	15.00 deg
Gmt (upright damaged)	18.293 ft	
Righting Area (0.00-%.00)	62.413 ft-deg	2.820 ft-deg

RTRN002A:
 105' DINNER BOAT

Imaged Compartments:
 FOREPEAK VOID

	DISPLACEMENT LTons	DRAFT AFT ft	DRAFT FWD ft	TRIM ft	HEEL deg.	UPRIGHT GMT ft
INTACT	264.8	6.350	5.920	0.430A	0.00	18.399
DAMAGED	277.8	6.017	6.692	0.675F	0.00	18.609

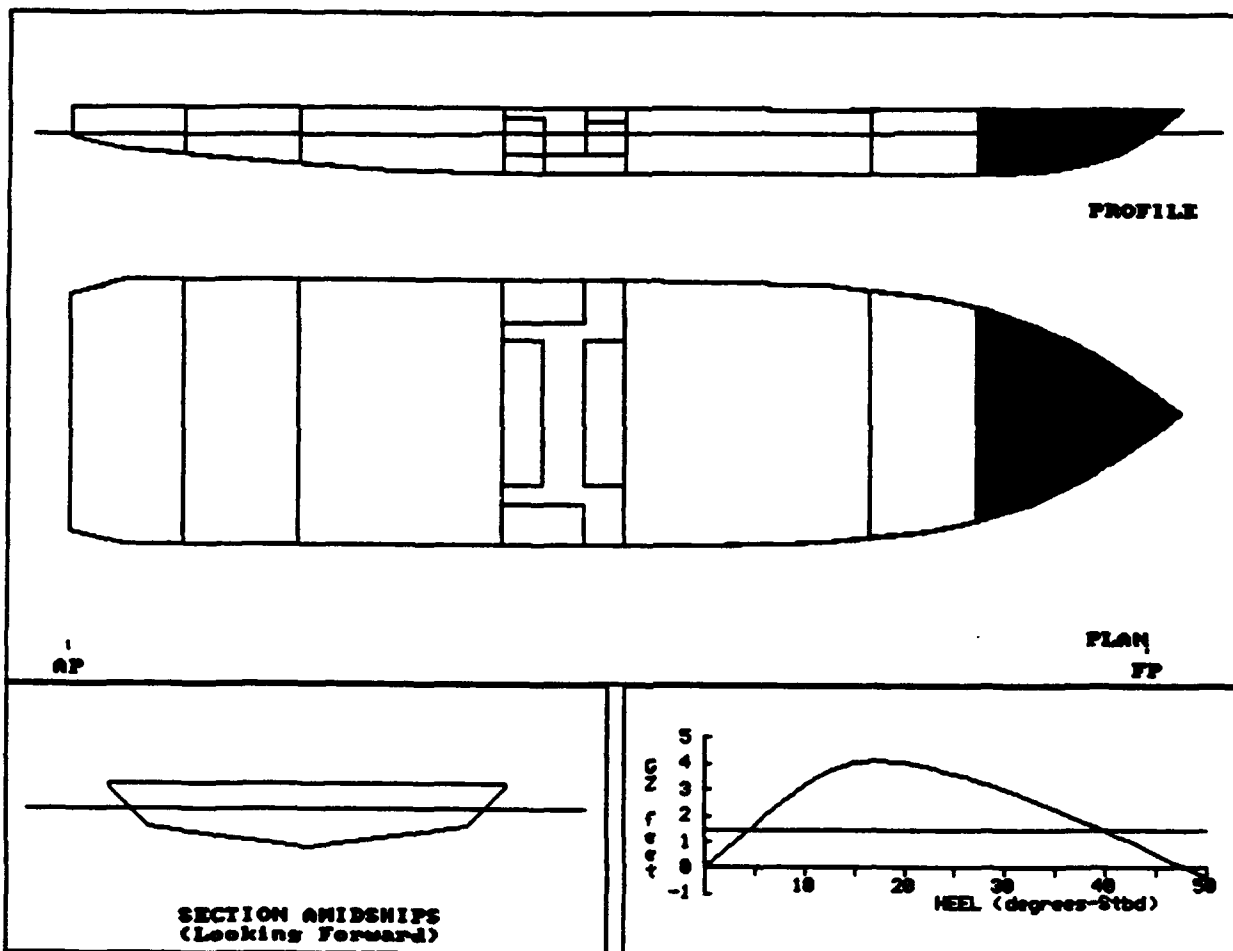

RTRN002A:
 105' DINNER BOAT

COMPARTMENT FLOODING SUMMARY

At 0.0o Heel	PERM.	FLOODED WTR LTons	% FULL (Damaged)	% FULL (Intact)	SP.VOL. ft3/LT	OUTFLOW LTons
FOREPEAK	0.95	1.0	FREE	0.0	----	----
VOID	0.95	12.0	FREE	0.0	----	----
Totals		13.0				

INTACT DATA

Draft at AP = 6.350 ft	KMt = 32.079 ft	LCG = 57.266A ft-FP
Draft at FP = 5.920 ft	VCG = 13.680 ft	LCB = 57.305A ft-FP
Displacement = 264.8 LTons	GMT = 18.399 ft	TCG = 0.000 ft-CL

DRAFT/GZ DATA

HEEL degrees	RIGHTING ARM ft	DRAFT AFT ft	DRAFT FWD ft	FLOODED WATER LTons
0.00	0.000	6.017	6.692	13.0
5.00S	1.627	5.963	6.634	12.9
7.00S	2.261	5.889	6.596	12.9
10.00S	3.132	5.685	6.531	13.0
15.00S	4.023	5.173	6.398	13.5
20.00S	4.029	4.624	6.421	14.9
30.00S	2.991	3.471	6.710	17.5
40.00S	1.422	2.031	7.333	19.7
50.00S	-0.341	0.097	8.295	21.4

Note: Drafts are measured at A.P. and F.P along ship's centerline

GZ SUMMARY (Evaluated per IMO (SOLAS'90) Rules for Passenger Ships)

	Available	Required
Static Heel Angle	0.00 deg	7.00 deg
Angle at Maximum GZ	18.00S deg	
Maximum GZ	4.112 ft	1.450 ft
Range of Positive GZ	48.08 deg	15.00 deg
Gmt (upright damaged)	18.609 ft	
Righting Area (0.00-%.00)	62.668 ft-deg	2.820 ft-deg

RTRN003A:
 105' DINNER BOAT

Damaged Compartments:
 VOID

	DISPLACEMENT LTons	DRAFT AFT ft	DRAFT FWD ft	TRIM ft	HEEL deg.	UPRIGHT GMT ft
INTACT	264.8	6.350	5.920	0.430A	0.00	18.399
DAMAGED	276.5	6.056	6.609	0.553F	0.00	18.574

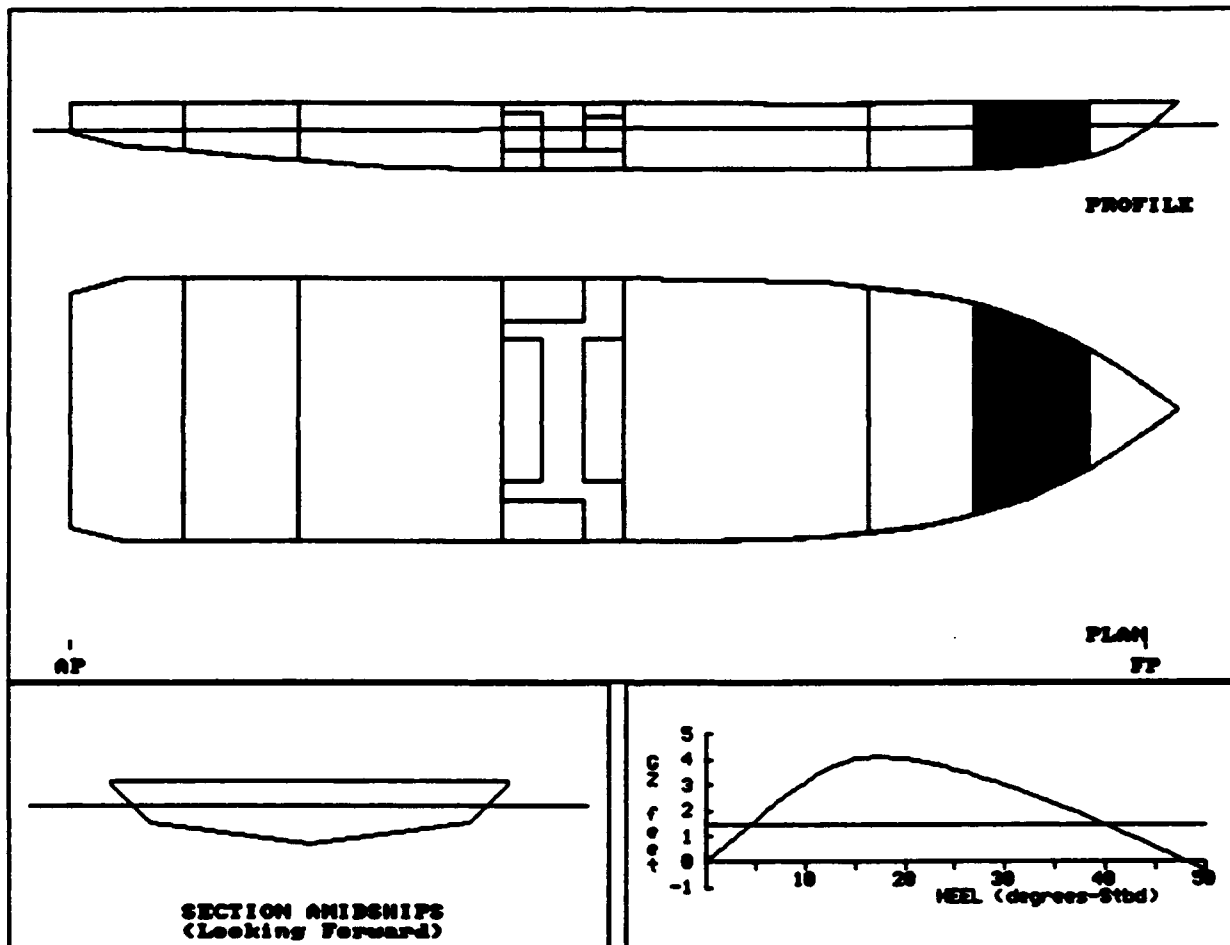

RTRM003A:
 105' DINNER BOAT

COMPARTMENT FLOODING SUMMARY

At 0.0o Heel	PERM.	FLOODED WTR LTons	% FULL (Damaged)	% FULL (Intact)	SP.VOL. ft3/LT	OUTFLOW LTons
VOID	0.95	11.7	FREE	0.0	----	----
Totals		11.7				

INTACT DATA

Draft at AP = 6.350 ft	Kmt = 32.079 ft	LCG = 57.266A ft-FP
Draft at FP = 5.920 ft	VCG = 13.680 ft	LCB = 57.305A ft-FP
Displacement = 264.8 LTons	Gmt = 18.399 ft	TCG = 0.000 ft-CL

DRAFT/GZ DATA

HEEL degrees	RIGHTING ARM ft	DRAFT AFT ft	DRAFT FWD ft	FLOODED WATER LTons
0.00	0.000	6.056	6.609	11.7
5.00S	1.624	6.003	6.551	11.7
7.00S	2.257	5.929	6.514	11.7
10.00S	3.125	5.725	6.450	11.8
15.00S	4.021	5.218	6.307	12.3
20.00S	4.030	4.684	6.302	13.5
30.00S	3.006	3.609	6.443	15.3
40.00S	1.453	2.341	6.757	16.3
50.00S	-0.298	0.675	7.253	17.0

Note: Drafts are measured at A.P. and F.P along ship's centerline

GZ SUMMARY (Evaluated per IMO (SOLAS'90) Rules for Passenger Ships)
 Available Required

Static Heel Angle	0.00 deg	7.00 deg
Angle at Maximum GZ	18.00S deg	
Maximum GZ	4.112 ft	1.450 ft
Range of Positive GZ	48.32 deg	15.00 deg
Gmt (upright damaged)	18.574 ft	
Righting Area (0.00-7.00)	62.612 ft-deg	2.820 ft-deg

RTRN004A:
 105' DINNER BOAT

Imaged Compartments:
 DRY STORES

	DISPLACEMENT LTons	DRAFT AFT ft	DRAFT FWD ft	TRIM ft	HEEL deg.	UPRIGHT GMT ft
INTACT	264.8	6.350	5.920	0.430A	0.00	18.399
DAMAGED	290.4	5.917	7.142	1.225F	0.00	17.855

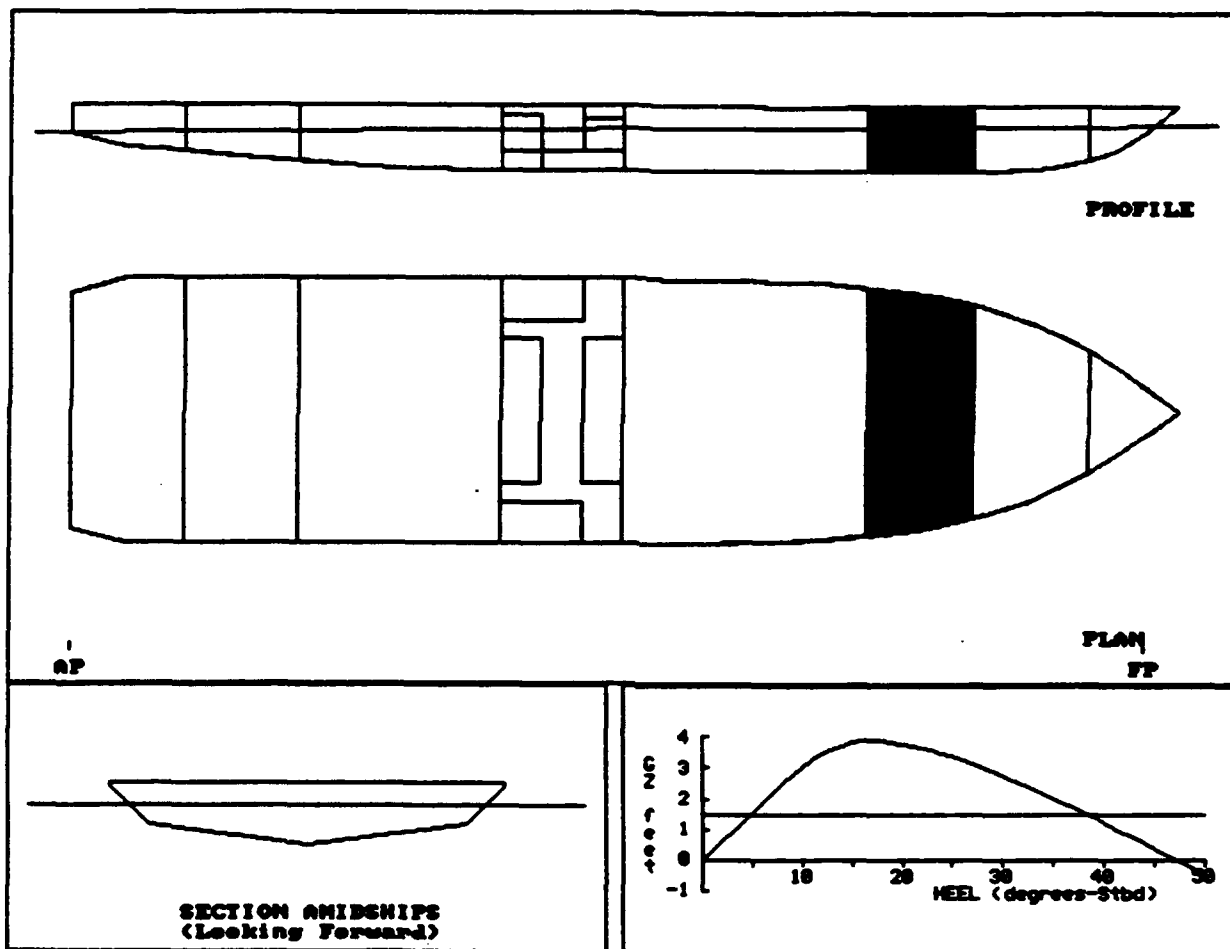

RTRN004A:
 105' DINNER BOAT

COMPARTMENT FLOODING SUMMARY

At 0.0o Heel	PERM.	FLOODED WTR LTons	% FULL (Damaged)	% FULL (Intact)	SP.VOL. ft3/LT	OUTFLOW LTons
DRY STORES	0.95	25.7	FREE	0.0	----	----
Totals		25.7				

INTACT DATA

Draft at AP = 6.350 ft	KMt = 32.079 ft	LCG = 57.266A ft-FP
Draft at FP = 5.920 ft	VCG = 13.680 ft	LCB = 57.305A ft-FP
Displacement = 264.8 LTons	GMT = 18.399 ft	TCG = 0.000 ft-CL

DRAFT/GZ DATA

HEEL degrees	RIGHTING ARM ft	DRAFT AFT ft	DRAFT FWD ft	FLOODED WATER LTons
0.00	0.000	5.917	7.142	25.7
5.00S	1.564	5.850	7.102	25.9
7.00S	2.174	5.768	7.077	26.2
10.00S	3.025	5.559	7.035	26.9
15.00S	3.823	5.034	7.007	27.8
20.00S	3.795	4.500	7.078	28.2
30.00S	2.758	3.440	7.361	28.6
40.00S	1.221	2.198	7.845	28.7
50.00S	-0.501	0.538	8.609	28.8

Note: Drafts are measured at A.P. and F.P along ship's centerline

GZ SUMMARY (Evaluated per IMO (SOLAS'90) Rules for Passenger Ships)

	Available	Required
Static Heel Angle	0.00 deg	7.00 deg
Angle at Maximum GZ	18.00S deg	
Maximum GZ	3.889 ft	1.450 ft
Range of Positive GZ	47.12 deg	15.00 deg
Gmt (upright damaged)	17.855 ft	
Righting Area (0.00-7.00)	59.728 ft-deg	2.820 ft-deg

RTRN005A:
 105' DINNER BOAT

Damaged Compartments:
 CATERER AREA

	DISPLACEMENT LTons	DRAFT AFT ft	DRAFT FWD ft	TRIM ft	HEEL deg.	UPRIGHT Gmt ft
INTACT	264.8	6.350	5.920	0.430A	0.00	18.399
DAMAGED	377.0	6.070	9.012	2.942F	0.00	16.004

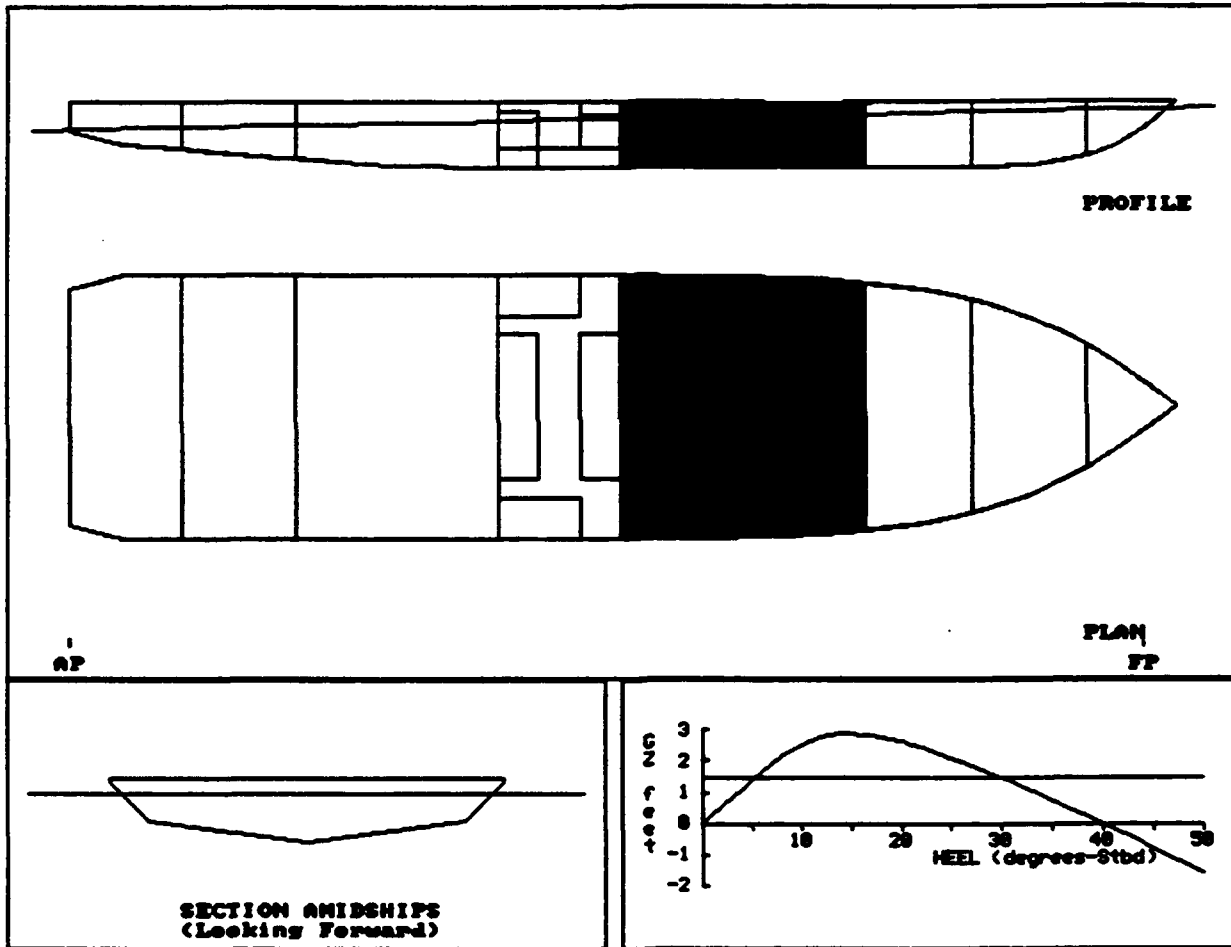

RTRN005A:
 105' DINNER BOAT

COMPARTMENT FLOODING SUMMARY

At 0.0o Heel	PERM.	FLOODED WTR LTons	% FULL (Damaged)	% FULL (Intact)	SP.VOL. ft3/LT	OUTFLOW LTons
CATERER AREA	0.95	112.2	FREE	0.0	----	----
Totals		112.2				

INTACT DATA

Draft at AP = 6.350 ft	KMt = 32.079 ft	LCG = 57.266A ft-FP
Draft at FP = 5.920 ft	VCG = 13.680 ft	LCB = 57.305A ft-FP
Displacement = 264.8 LTons	GMT = 18.399 ft	TCG = 0.000 ft-CL

DRAFT/GZ DATA

HEEL degrees	RIGHTING ARM ft	DRAFT AFT ft	DRAFT FWD ft	FLOODED WATER LTons
0.00	0.000	6.070	9.012	112.2
5.00S	1.401	6.015	8.943	112.0
7.00S	1.923	5.946	8.914	111.9
10.00S	2.535	5.748	8.989	110.8
15.00S	2.880	5.307	9.399	108.6
20.00S	2.624	4.890	9.954	107.0
30.00S	1.459	4.023	11.419	105.4
40.00S	-0.016	2.983	13.423	104.5
50.00S	-1.580	1.604	16.232	104.0

Note: Drafts are measured at A.P. and F.P along ship's centerline

GZ SUMMARY (Evaluated per IMO (SOLAS'90) Rules for Passenger Ships)

	Available	Required
Static Heel Angle	0.00 deg	7.00 deg
Angle at Maximum GZ	16.00S deg	
Maximum GZ	2.880 ft	1.450 ft
Range of Positive GZ	39.89 deg	15.00 deg
Gmt (upright damaged)	16.004 ft	
Righting Area (0.00-7.00)	46.439 ft-deg	2.820 ft-deg

RTRN006A:
 105' DINNER BOAT

Damaged Compartments:
 TANKS

	DISPLACEMENT LTons	DRAFT AFT ft	DRAFT FWD ft	TRIM ft	HEEL deg.	UPRIGHT GMT ft
INTACT	264.8	6.350	5.920	0.430A	0.00	18.399
DAMAGED	288.6	6.561	6.274	0.287A	0.00	17.487

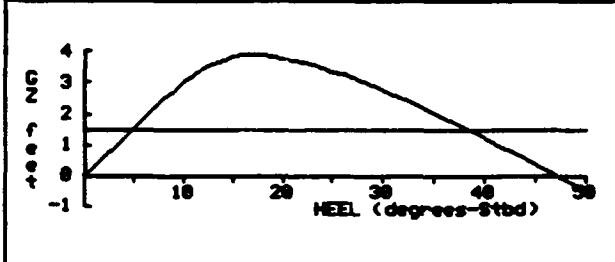
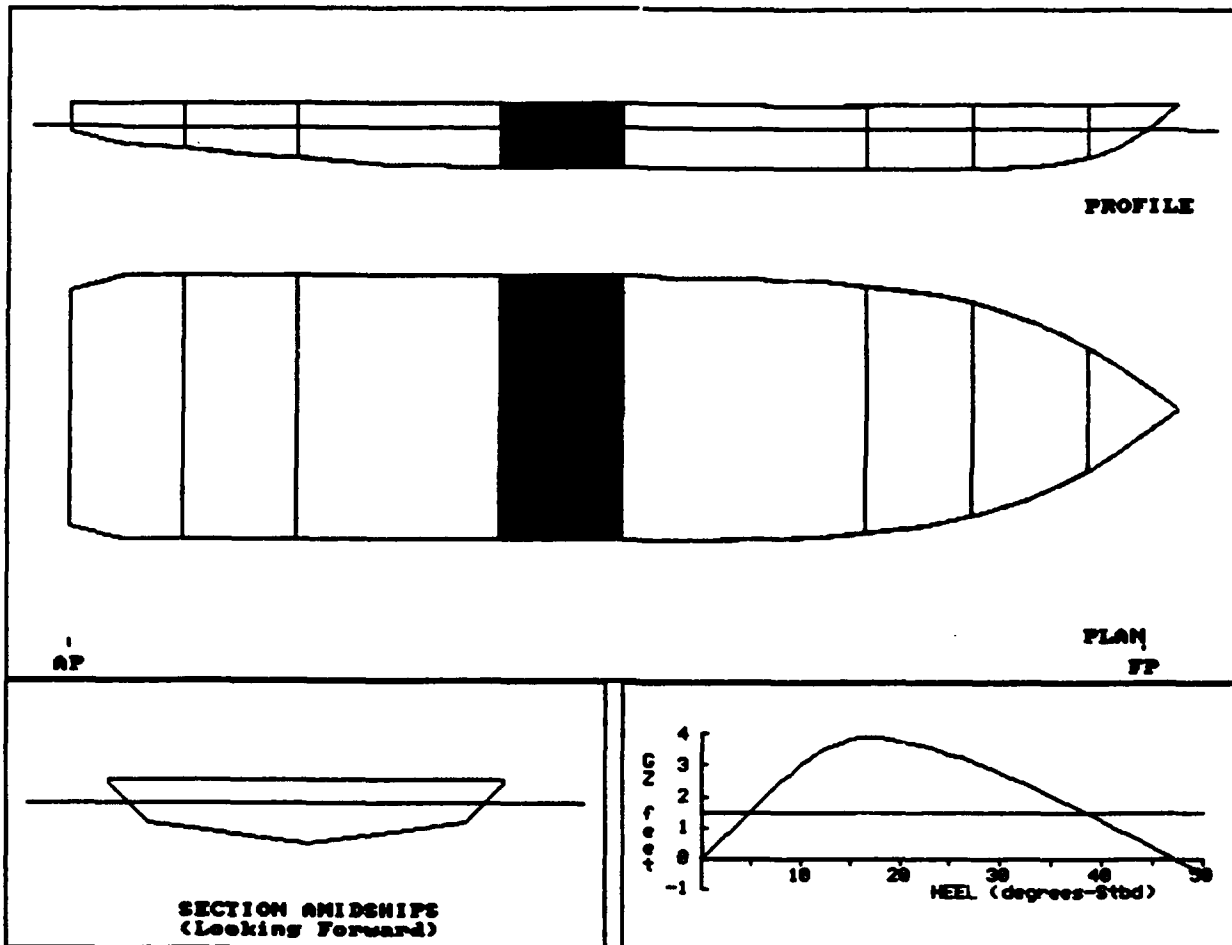

RTRN006A:
 105' DINNER BOAT

COMPARTMENT FLOODING SUMMARY

At 0.0o Heel	PERM.	FLOODED WTR LTons	% FULL (Damaged)	% FULL (Intact)	SP.VOL. ft3/LT	OUTFLOW LTons
TANKS	0.95	23.8	FREE	0.0	----	----
Totals		23.8				

INTACT DATA

Draft at AP = 6.350 ft	KMt = 32.079 ft	LCG = 57.266A ft-FP
Draft at FP = 5.920 ft	VCG = 13.680 ft	LCB = 57.305A ft-FP
Displacement = 264.8 LTons	GMT = 18.399 ft	TCG = 0.000 ft-CL

DRAFT/GZ DATA

HEEL degrees	RIGHTING ARM ft	DRAFT AFT ft	DRAFT FWD ft	FLOODED WATER LTons
0.00	0.000	6.561	6.274	23.8
5.00S	1.536	6.509	6.222	23.7
7.00S	2.152	6.449	6.174	23.6
10.00S	3.008	6.286	6.074	23.3
15.00S	3.824	5.916	5.835	22.9
20.00S	3.786	5.633	5.623	23.1
30.00S	2.749	5.139	5.265	23.3
40.00S	1.221	4.600	4.961	23.3
50.00S	-0.488	3.921	4.629	23.2

Note: Drafts are measured at A.P. and F.P along ship's centerline

GZ SUMMARY (Evaluated per IMO (SOLAS'90) Rules for Passenger Ships)
 Available Required

Static Heel Angle	0.00 deg	7.00 deg
Angle at Maximum GZ	18.00S deg	
Maximum GZ	3.889 ft	1.450 ft
Range of Positive GZ	47.17 deg	15.00 deg
Gmt (upright damaged)	17.487 ft	
Righting Area (0.00-%.00)	59.464 ft-deg	2.820 ft-deg

RTRN007A:
 105' DINNER BOAT

Damaged Compartments:
 TANKS FOTANK STBD

	DISPLACEMENT LTons	DRAFT AFT ft	DRAFT FWD ft	TRIM ft	HEEL deg.	UPRIGHT GMT ft
INTACT	264.8	6.350	5.920	0.430A	0.00	18.399
DAMAGED	290.1	6.577	6.290	0.287A	0.27S	16.814

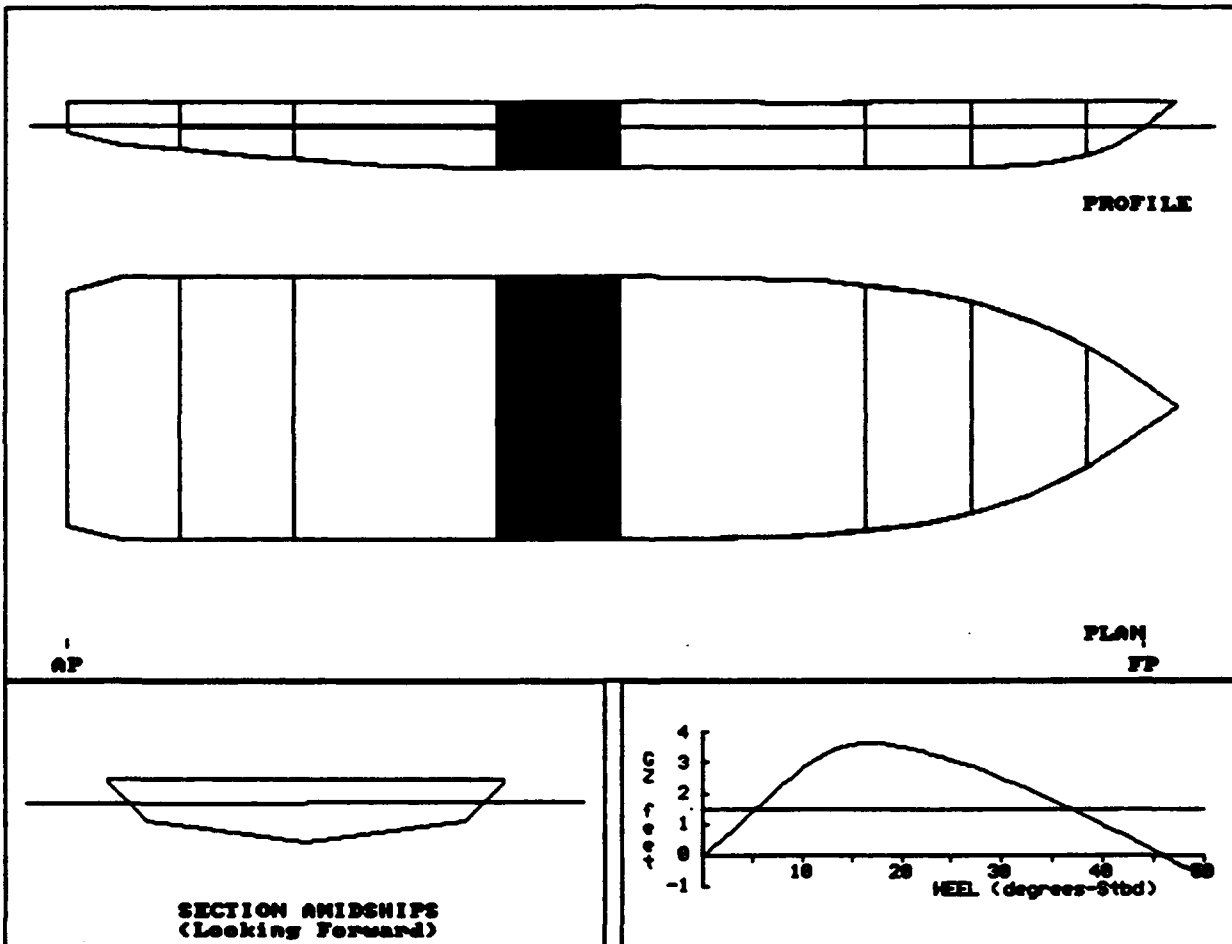

RTRN007A:
 105' DINNER BOAT

COMPARTMENT FLOODING SUMMARY

At 0.3oS Heel	PERM.	FLOODED WTR LTons	% FULL (Damaged)	% FULL (Intact)	SP.VOL. ft3/LT	OUTFLOW LTons
TANKS	0.95	23.9	FREE	0.0	----	----
FOTANK STBD	0.95	2.0	FREE	10.0	40.6000	0.5
Totals		25.9				0.5

INTACT DATA

Draft at AP = 6.350 ft Kmt = 32.079 ft LCG = 57.266A ft-FP
 Draft at FP = 5.920 ft VCG = 13.680 ft LCB = 57.305A ft-FP
 Displacement = 264.8 LTons GMT = 18.399 ft TCG = 0.000 ft-CL

DRAFT/GZ DATA

HEEL degrees	RIGHTING ARM ft	DRAFT AFT ft	DRAFT FWD ft	FLOODED WATER LTons
0.00	-0.080	6.578	6.292	25.8
5.00S	1.395	6.551	6.242	27.1
7.00S	1.989	6.503	6.197	27.6
10.00S	2.817	6.342	6.124	28.3
15.00S	3.579	6.015	5.900	29.0
20.00S	3.529	5.768	5.698	29.4
30.00S	2.494	5.350	5.363	29.6
40.00S	0.982	4.905	5.081	29.6
50.00S	-0.703	4.354	4.777	29.5

Note: Drafts are measured at A.P. and F.P along ship's centerline

GZ SUMMARY (Evaluated per IMO (SOLAS'90) Rules for Passenger Ships)

	Available	Required
Static Heel Angle	0.27S deg	7.00 deg
Angle at Maximum GZ	18.00S deg	
Maximum GZ	3.634 ft	1.450 ft
Range of Positive GZ	45.60 deg	15.00 deg
Righting Area (0.27-%.00)	55.207 ft-deg	2.820 ft-deg

RTRN008A:
 105' DINNER BOAT

Imaged Compartments:
 ENGINE ROOM

	DISPLACEMENT LTons	DRAFT AFT ft	DRAFT FWD ft	TRIM ft	HEEL deg.	UPRIGHT GMT ft
INTACT	264.8	6.350	5.920	0.430A	0.00	18.399
DAMAGED	339.8	7.943	5.792	2.150A	0.00	15.712

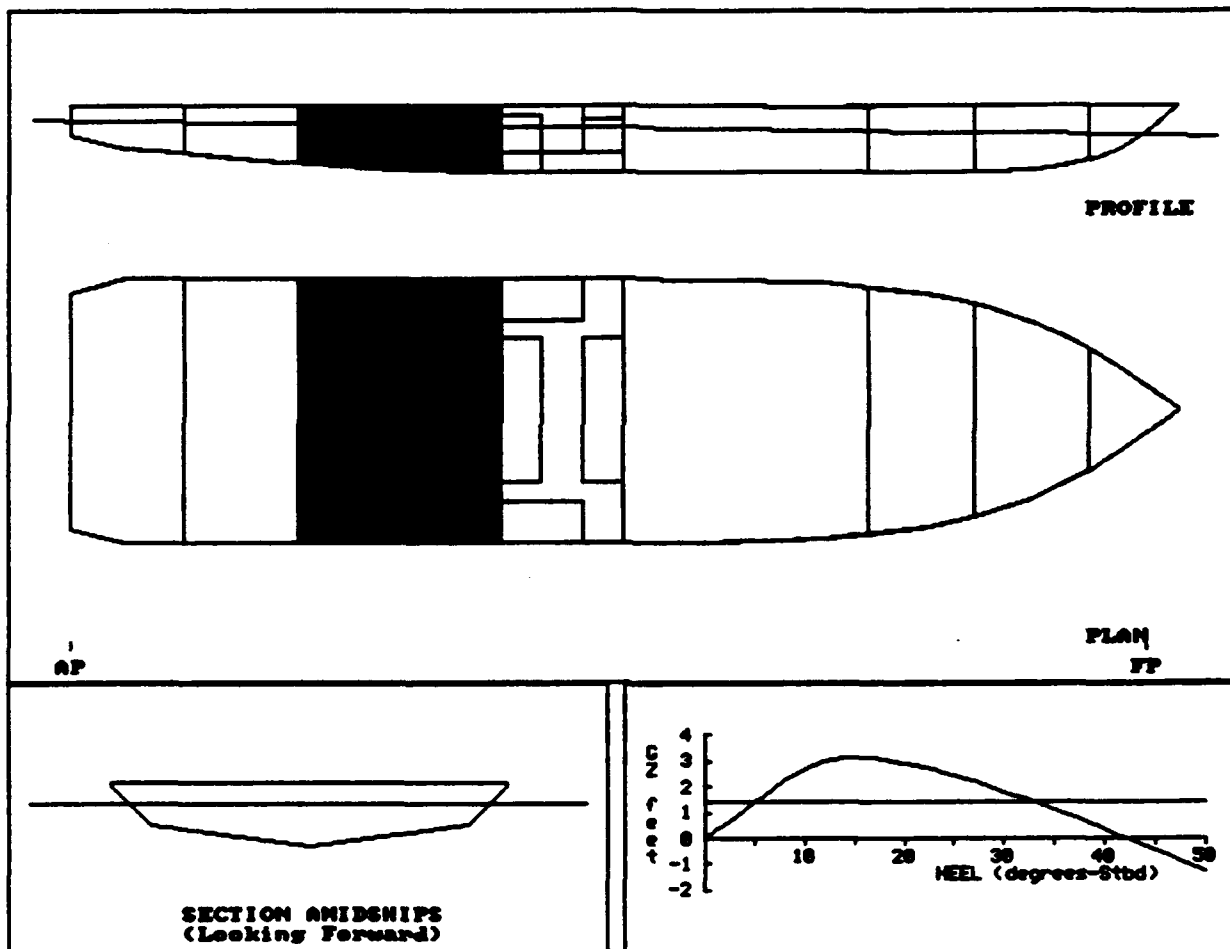

RTRN008A:
 105' DINNER BOAT

COMPARTMENT FLOODING SUMMARY

At 0.0o Heel	PERM.	FLOODED WTR LTons	% FULL (Damaged)	% FULL (Intact)	SP.VOL. ft3/LT	OUTFLOW LTons
ENGINE ROOM	0.85	75.0	FREE	0.0	----	----
Totals		75.0				

INTACT DATA

Draft at AP = 6.350 ft	KMT = 32.079 ft	LCG = 57.266A ft-FP
Draft at FP = 5.920 ft	VCG = 13.680 ft	LCB = 57.305A ft-FP
Displacement = 264.8 LTons	GMT = 18.399 ft	TCG = 0.000 ft-CL

DRAFT/GZ DATA

HEEL degrees	RIGHTING ARM ft	DRAFT AFT ft	DRAFT FWD ft	FLOODED WATER LTons
0.00	0.000	7.943	5.792	75.0
5.00S	1.382	7.889	5.742	74.9
7.00S	1.945	7.840	5.688	74.9
10.00S	2.667	7.833	5.512	75.0
15.00S	3.120	8.046	5.075	74.5
20.00S	2.925	8.378	4.644	74.1
30.00S	1.816	9.247	3.800	73.5
40.00S	0.341	10.412	2.871	73.2
50.00S	-1.257	12.046	1.693	73.1

Note: Drafts are measured at A.P. and F.P along ship's centerline

GZ SUMMARY (Evaluated per IMO (SOLAS'90) Rules for Passenger Ships)
 Available Required

Static Heel Angle	0.00 deg	7.00 deg
Angle at Maximum GZ	16.00S deg	
Maximum GZ	3.120 ft	1.450 ft
Range of Positive GZ	42.17 deg	15.00 deg
Gmt (upright damaged)	15.712 ft	
Righting Area (0.00-7.00)	49.536 ft-deg	2.820 ft-deg

RTRM009A:
 105' DINNER BOAT

Damaged Compartments:
 EXH SILENCER

	DISPLACEMENT LTons	DRAFT AFT ft	DRAFT FWD ft	TRIM ft	HEEL deg.	UPRIGHT GMT ft
INTACT	264.8	6.350	5.920	0.430A	0.00	18.399
DAMAGED	299.9	7.522	5.303	2.219A	0.00	16.183

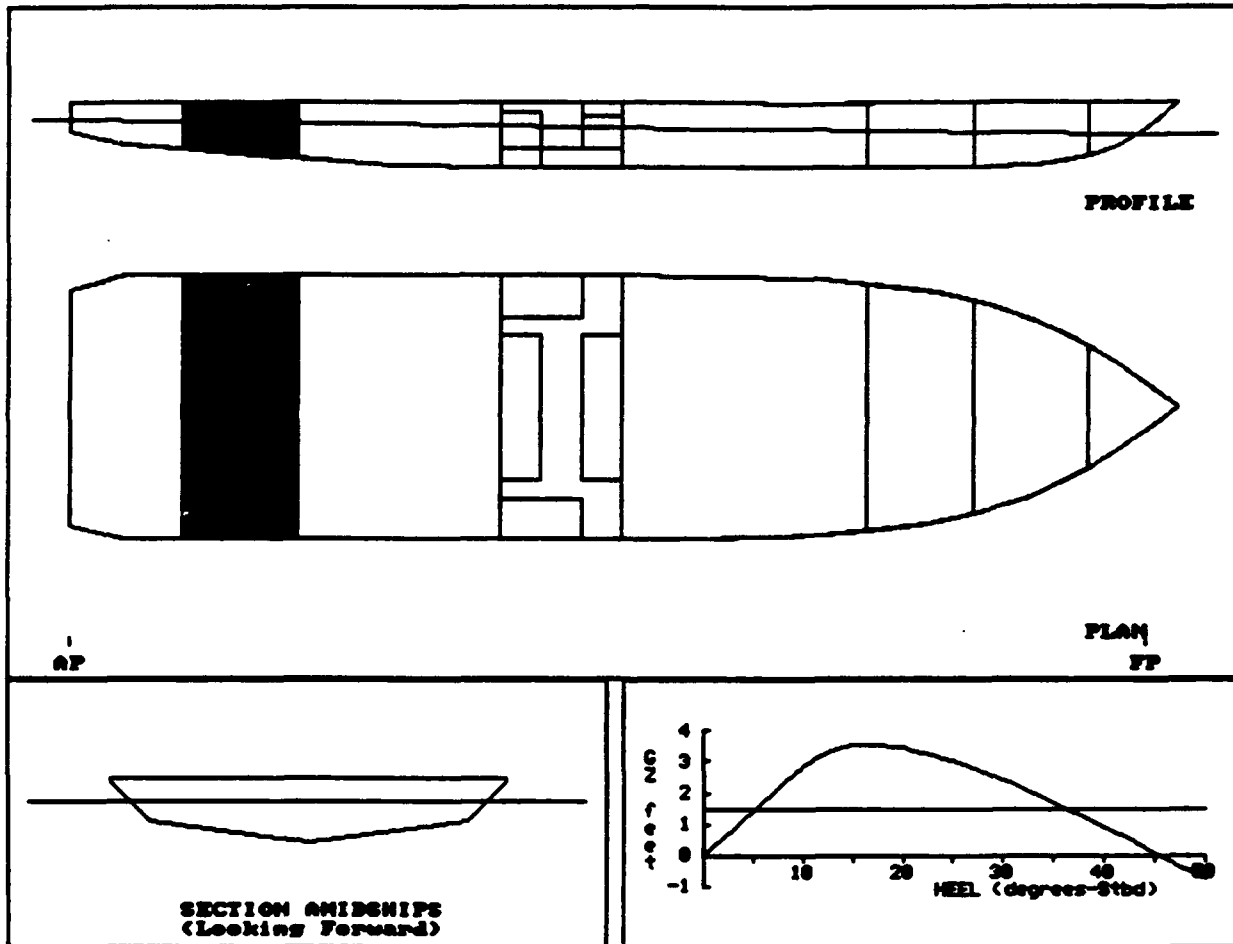

RTRM009A:
105' DINNER BOAT

COMPARTMENT FLOODING SUMMARY

At 0.0o Heel	PERM.	FLOODED WTR LTons	% FULL (Damaged)	% FULL (Intact)	SP.VOL. ft3/LT	OUTFLOW LTons
EXH SILENCER	0.95	35.1	FREE	0.0	----	----
Totals		35.1				

INTACT DATA

Draft at AP = 6.350 ft	KMT = 32.079 ft	LCG = 57.266A ft-FP
Draft at FP = 5.920 ft	VCG = 13.680 ft	LCB = 57.305A ft-FP
Displacement = 264.8 LTons	GMT = 18.399 ft	TCG = 0.000 ft-CL

DRAFT/GZ DATA

HEEL degrees	RIGHTING ARM ft	DRAFT AFT ft	DRAFT FWD ft	FLOODED WATER LTons
0.00	0.000	7.522	5.303	35.1
5.00S	1.422	7.476	5.246	35.2
7.00S	1.996	7.428	5.190	35.2
10.00S	2.817	7.345	5.045	35.2
15.00S	3.496	7.318	4.608	35.1
20.00S	3.432	7.428	4.115	35.2
30.00S	2.399	7.837	3.124	35.6
40.00S	0.904	8.460	1.990	36.0
50.00S	-0.763	9.355	0.543	36.2

Note: Drafts are measured at A.P. and F.P along ship's centerline

GZ SUMMARY (Evaluated per IMO (SOLAS'90) Rules for Passenger Ships)

	Available	Required
Static Heel Angle	0.00 deg	7.00 deg
Angle at Maximum GZ	18.00S deg	
Maximum GZ	3.537 ft	1.450 ft
Range of Positive GZ	45.47 deg	15.00 deg
Gmt (upright damaged)	16.183 ft	
Righting Area (0.00-%.00)	54.637 ft-deg	2.820 ft-deg

RTRN010A:
 105' DINNER BOAT

Damaged Compartments:
 STEERING RON

	DISPLACEMENT LTons	DRAFT AFT ft	DRAFT FWD ft	TRIM ft	HEEL deg.	UPRIGHT GMT ft
INTACT	264.8	6.350	5.920	0.430A	0.00	18.399
DAMAGED	288.5	7.338	5.244	2.094A	0.00	15.964

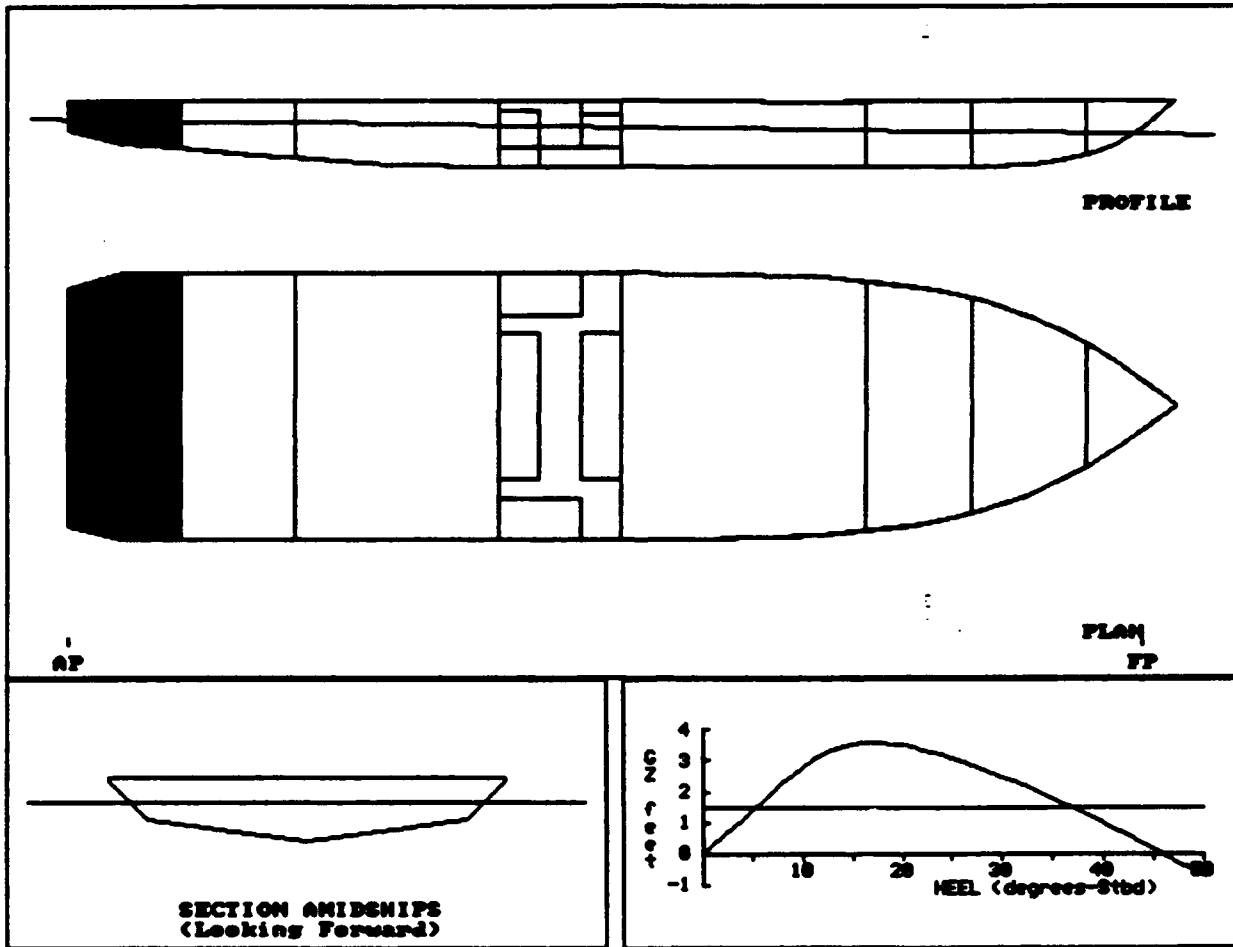

RTRN010A:
 105' DINNER BOAT

COMPARTMENT FLOODING SUMMARY

At 0.0o Heel	PERM.	FLOODED WTR LTons	% FULL (Damaged)	% FULL (Intact)	SP.VOL. ft3/LT	OUTFLOW LTons
STEERING ROM	0.95	23.7	FREE	0.0	----	----
Totals		23.7				

INTACT DATA

Draft at AP = 6.350 ft	KMT = 32.079 ft	LCG = 57.266A ft-FP
Draft at FP = 5.920 ft	VCG = 13.680 ft	LCB = 57.305A ft-FP
Displacement = 264.8 LTons	GMT = 18.399 ft	TCG = 0.000 ft-CL

DRAFT/GZ DATA

HEEL degrees	RIGHTING ARM ft	DRAFT AFT ft	DRAFT FWD ft	FLOODED WATER LTons
0.00	0.000	7.338	5.244	23.7
5.00S	1.402	7.300	5.181	23.9
7.00S	1.969	7.259	5.119	24.1
10.00S	2.796	7.178	4.968	24.6
15.00S	3.531	7.125	4.511	25.3
20.00S	3.499	7.231	3.971	26.2
30.00S	2.487	7.637	2.877	27.5
40.00S	0.985	8.289	1.593	28.4
50.00S	-0.699	9.240	-0.074	29.1

Note: Drafts are measured at A.P. and F.P along ship's centerline

GZ SUMMARY (Evaluated per IMO (SOLAS'90) Rules for Passenger Ships)

	Available	Required
Static Heel Angle	0.00 deg	7.00 deg
Angle at Maximum GZ	18.00S deg	
Maximum GZ	3.588 ft	1.450 ft
Range of Positive GZ	45.89 deg	15.00 deg
Gmt (upright damaged)	15.964 ft	
Righting Area (0.00-7.00)	54.898 ft-deg	2.820 ft-deg

**APPENDIX B
HYDROSTATICS AND
DAMAGE STABILITY
OUTPUT**

106' DINNER BOAT

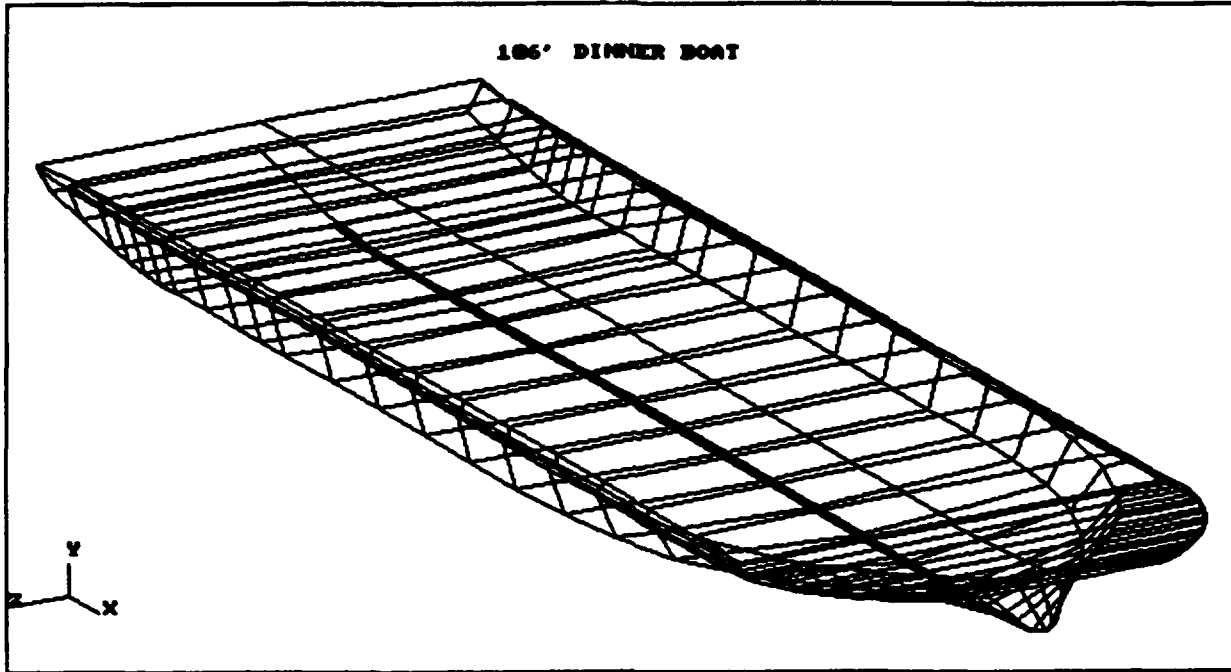

DAMAGE STABILITY SUMMARY
 106'ER

DEPART

FILE NAME	DAMAGED COMP. LISTING	---Intact Condition---			-----Equilibrium Condition After Damage-----							
		MIN.DRAFT (ft)	VCG (ft)	GMT (ft)	HEEL (deg)	MAX.GZ (ft)	RANGE (deg)	AREA (ft-deg)	DAM.GMT (ft)	DOWNFLD (ft)	MARGLINE (ft)	SURVIVAL
1	1	4.290	12.800	12.529	0.0	2.881	37.54	63.04	12.234	3.276	2.071	Yes
2	2	4.290	12.800	12.529	0.0	2.421	35.07	50.77	11.309	3.464	1.349	Yes
3	1,2	4.290	12.800	12.529	0.0	2.111	32.38	41.67	11.304	3.632	0.874	Yes
4	3	4.290	12.800	12.529	0.0	1.915	31.76	37.28	9.856	3.307	0.787	Yes
5	4	4.290	12.800	12.529	0.0	2.091	33.00	41.61	10.251	2.957	1.407	Yes
6	5	4.290	12.800	12.529	0.0	1.766	30.58	33.02	9.460	2.417	1.425	Yes
7	6	4.290	12.800	12.529	0.0	1.972	32.21	38.61	10.093	2.282	1.414	Yes
8	7	4.290	12.800	12.529	0.0	1.721	30.36	32.29	9.969	1.728	0.891	Yes
9	8	4.290	12.800	12.529	0.0	1.950	32.09	37.77	9.661	2.146	1.314	Yes

DAMAGE STABILITY SUMMARY
 106'ER

RETURN

FILE NAME	DAMAGED COMP. LISTING	---Intact Condition---			-----Equilibrium Condition After Damage-----							
		MIN.DRAFT (ft)	VCG (ft)	GMT (ft)	HEEL (deg)	MAX.GZ (ft)	RANGE (deg)	AREA (ft-deg)	DAM.GMT (ft)	DOWNFLD (ft)	MARGLINE (ft)	SURVIVAL
1RNO01B	1	4.240	13.150	12.428	0.0	2.863	36.84	61.34	12.084	3.324	2.124	Yes
2 RTRNO02B	2	4.240	13.150	12.428	0.0	2.409	34.45	49.50	11.174	3.513	1.412	Yes
3 RTRNO03B	1,2	4.240	13.150	12.428	0.0	2.107	31.88	40.87	11.176	3.679	0.945	Yes
4 RTRNO04B	3	4.240	13.150	12.428	0.0	1.908	31.24	36.41	9.689	3.359	0.851	Yes
5 RTRNO05B	4	4.240	13.150	12.428	0.0	2.085	32.42	40.58	10.076	3.011	1.465	Yes
6 RTRNO06B	5	4.240	13.150	12.428	0.0	1.761	30.11	32.36	9.298	2.477	1.484	Yes
7 RTRNO07B	6	4.240	13.150	12.428	0.0	1.970	31.70	37.82	9.945	2.343	1.474	Yes
8 RTRNO08B	7	4.240	13.150	12.428	0.0	1.723	29.94	31.81	9.818	1.794	0.957	Yes
9 RTRNO09B	8	4.240	13.150	12.428	0.0	1.946	31.60	37.02	9.514	2.222	1.388	Yes

DPRT001A: FOREPEAK
 106' DINNER BOAT

Imaged Compartments:
 FPK

	DISPLACEMENT LTons	DRAFT AFT ft	DRAFT FWD ft	TRIM ft	HEEL deg.	UPRIGHT CNT ft
INTACT	299.5	4.290	4.290	0.000	0.00	12.529
DAMAGED	304.4	4.153	4.580	0.427F	0.00	12.234

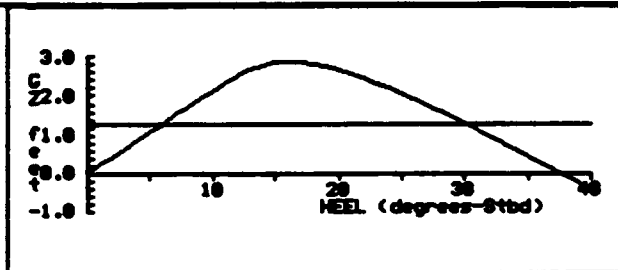
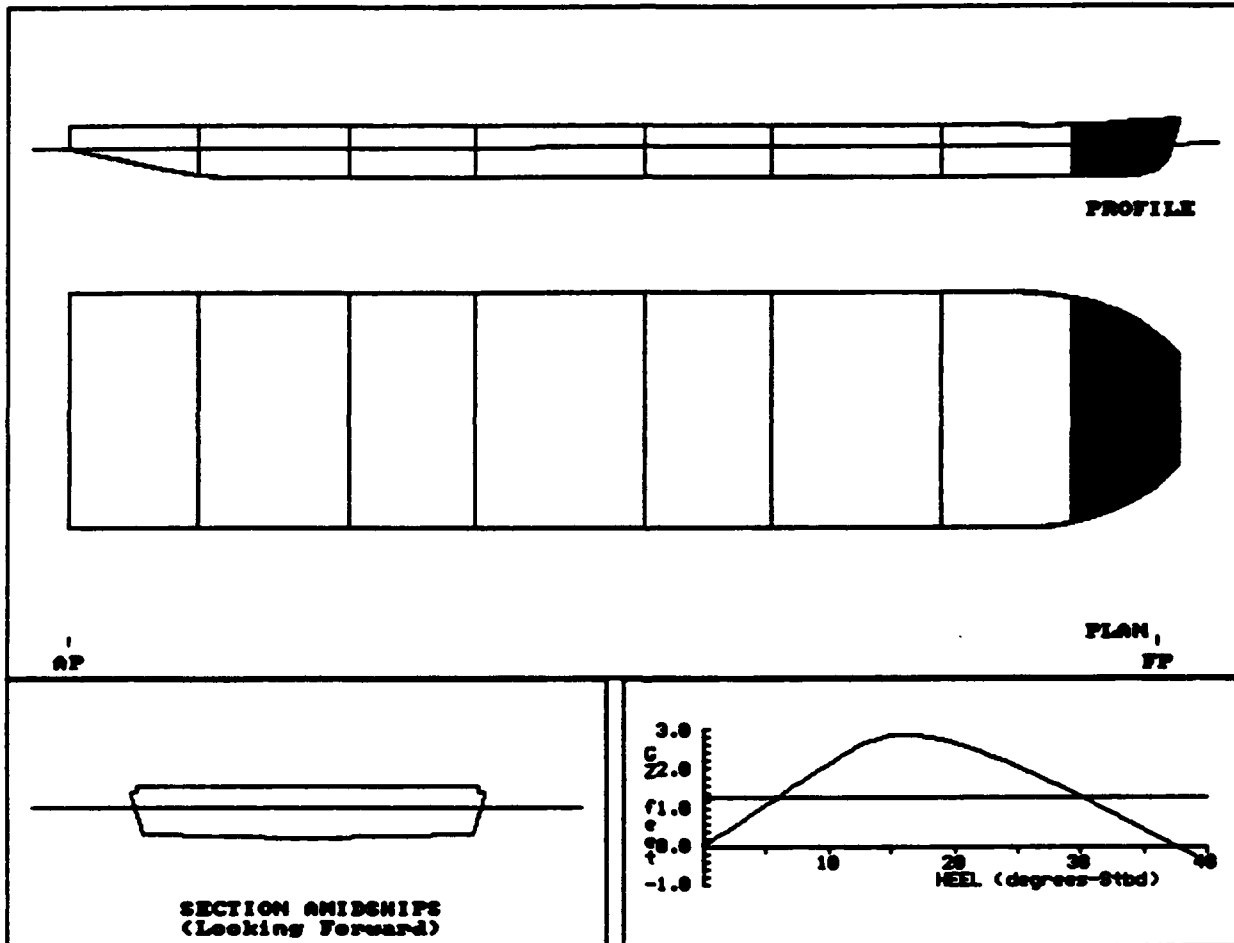

DPRT001A: FOREPEAK
106' DINNER BOAT

COMPARTMENT FLOODING SUMMARY

At 0.0o Heel	PERM.	FLOODED WTR LTons	% FULL (Damaged)	% FULL (Intact)	SP.VOL. ft3/LT	OUTFLOW LTons
FPK	0.95	4.9	FREE	0.0	----	----
Totals		4.9				

INTACT DATA

Draft at AP = 4.290 ft Kmt = 25.329 ft LCG = 54.799A ft-FP
 Draft at FP = 4.290 ft VCG = 12.800 ft LCB = 54.799A ft-FP
 Displacement = 299.5 LTons Gmt = 12.529 ft TCG = 0.000 ft-CL

DRAFT/GZ DATA

HEEL degrees	RIGHTING ARM ft	DRAFT AFT ft	DRAFT FWD ft	FLOODED WATER LTons
0.00	0.000	4.153	4.580	4.9
5.00S	1.074	4.131	4.562	4.9
7.00S	1.502	4.104	4.550	4.9
10.00S	2.132	4.063	4.510	4.9
15.00S	2.851	3.997	4.517	5.4
20.00S	2.664	3.947	4.639	6.2
22.00S	2.458	3.929	4.697	6.5
30.00S	1.309	3.855	4.975	7.5
35.00S	0.455	3.796	5.198	7.9
40.00S	-0.446	3.726	5.464	8.3

Note: Drafts are measured at A.P. and F.P along ship's centerline

GZ SUMMARY (Evaluated per IMO (SOLAS'90) Rules for Passenger Ships)
Available Required

Static Heel Angle	0.00 deg	7.00 deg
Freeboard to Margin Line	2.071 ft	0.000 ft
Freeboard to Downflooding	3.276 ft	
Angle at Maximum GZ	17.00S deg	
Maximum GZ	2.881 ft	1.300 ft
Range of Positive GZ	37.54 deg	15.00 deg
Gmt (upright damaged)	12.234 ft	
Righting Area (0.00-%.00)	42.684 ft-deg	2.820 ft-deg

DPRT002A: VOID1
 106' DINNER BOAT

Imaged Compartments:
 VOID 8-20

	DISPLACEMENT LTons	DRAFT AFT ft	DRAFT FWD ft	TRIM ft	HEEL deg.	UPRIGHT GMT ft
INTACT	299.5	4.290	4.290	0.000	0.00	12.529
DAMAGED	329.4	3.695	5.743	2.048F	0.00	11.309

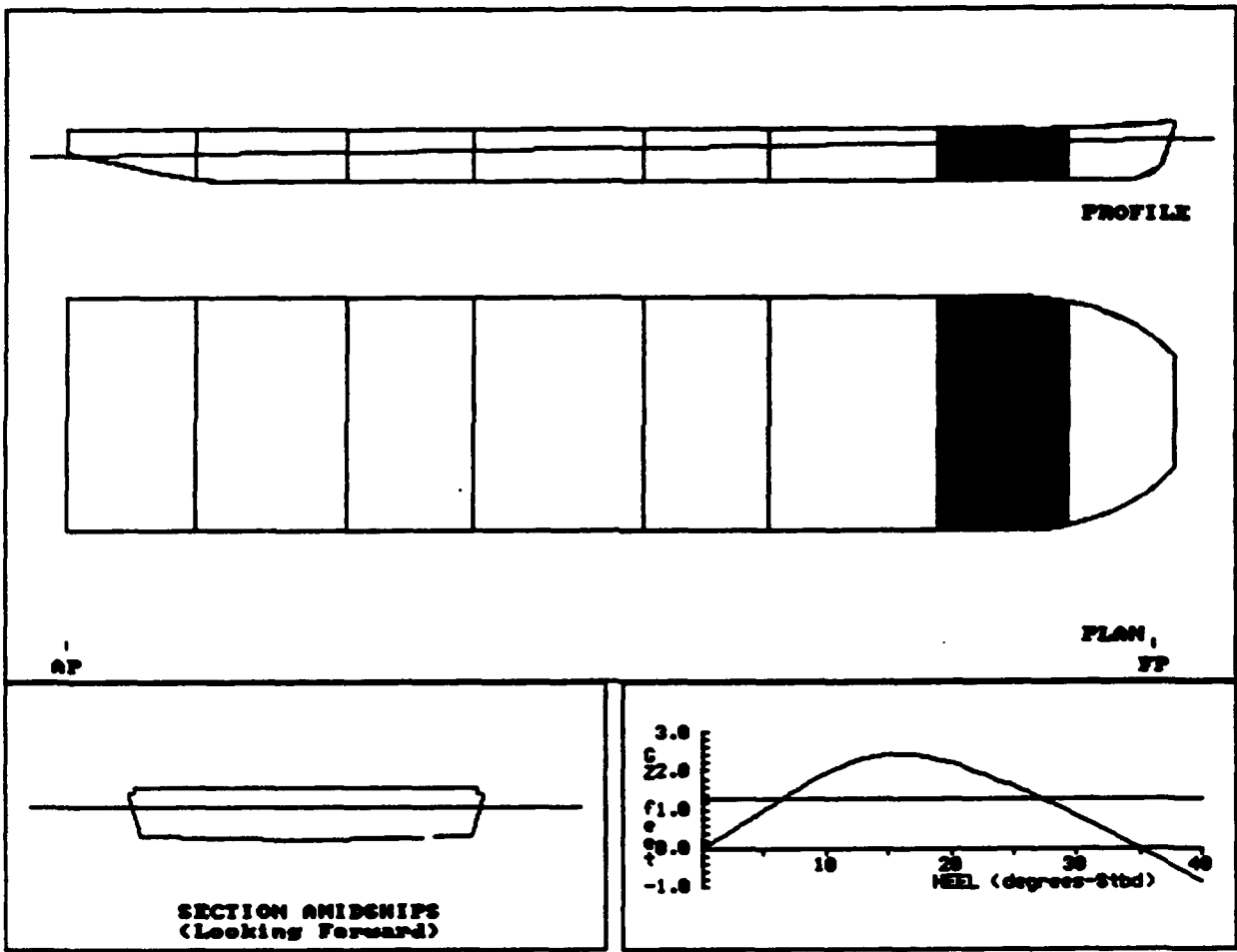

DEPT002A: VOID1
 106' DINNER BOAT

COMPARTMENT FLOODING SUMMARY

At 0.0o Heel'	PERM.	FLOODED WTR LTons	% FULL (Damaged)	% FULL (Intact)	SP.VOL. ft3/LT	OUTFLOW LTons
VOID 8-20	0.95	29.9	FREE	0.0	----	----
Totals		29.9				

INTACT DATA

Draft at AP = 4.290 ft Kmt = 25.329 ft LCG = 54.799A ft-FP
 Draft at FP = 4.290 ft VCG = 12.800 ft LCB = 54.799A ft-FP
 Displacement = 299.5 LTons Gmt = 12.529 ft TCG = 0.000 ft-CL

DRAFT/GZ DATA

HEEL degrees	RIGHTING ARM ft	DRAFT AFT ft	DRAFT FWD ft	FLOODED WATER LTons
0.00	0.000	3.695	5.743	29.9
5.00S	0.998	3.652	5.745	30.3
7.00S	1.385	3.614	5.748	30.9
10.00S	1.930	3.545	5.762	31.3
15.00S	2.414	3.343	6.084	32.2
20.00S	2.200	3.103	6.653	33.1
22.00S	1.992	2.998	6.908	33.3
30.00S	0.851	2.523	8.073	34.1
35.00S	0.013	2.159	8.955	34.5
40.00S	-0.866	1.734	9.982	34.9

Note: Drafts are measured at A.P. and F.P along ship's centerline

GZ SUMMARY (Evaluated per IMO (SOLAS'90) Rules for Passenger Ships)

	Available	Required
Static Heel Angle	0.00 deg	7.00 deg
Freeboard to Margin Line	1.349 ft	0.000 ft
Freeboard to Downflooding	3.464 ft	
Angle at Maximum GZ	17.00S deg	
Maximum GZ	2.421 ft	1.300 ft
Range of Positive GZ	35.07 deg	15.00 deg
Gmt (upright damaged)	11.309 ft	
Righting Area (0.00- $\frac{1}{2}$.00)	36.970 ft-deg	2.820 ft-deg

DPR203A: FRPK/VOID1
 106' DINNER BOAT

Damaged Compartments:
 FRPK VOID 8-20

	DISPLACEMENT LTons	DRAFT AFT ft	DRAFT FWD ft	TRIM ft	HEEL deg.	UPRIGHT GMT ft
INTACT	299.5	4.290	4.290	0.000	0.00	12.529
DAMAGED	343.1	3.347	6.472	3.125F	0.00	11.304

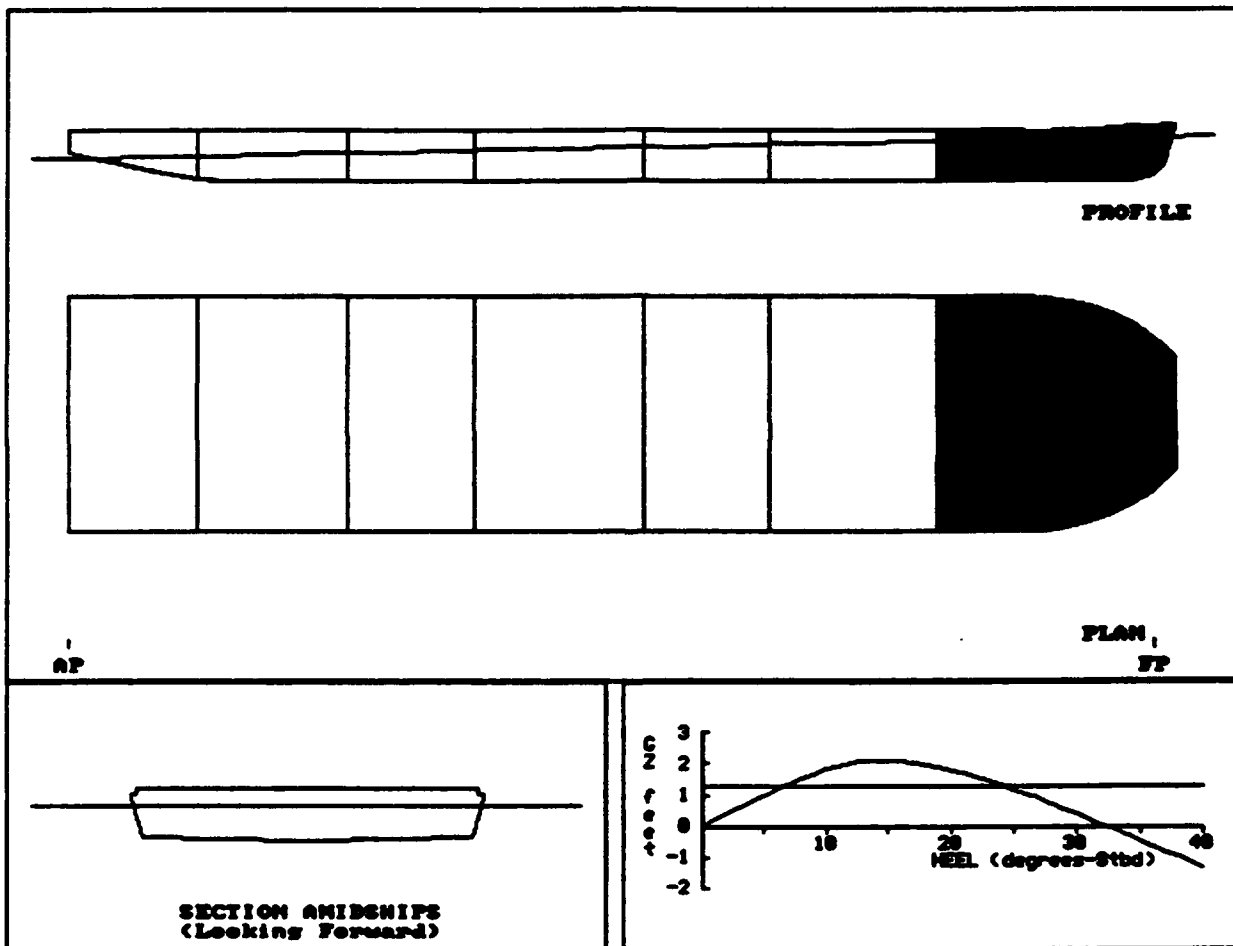

DPRT003A: FRPK/VOID1
106' DINNER BOAT

COMPARTMENT FLOODING SUMMARY

At 0.0o Heel	PERM.	FLOODED WTR LTons	% FULL (Damaged)	% FULL (Intact)	SP.VOL. ft3/LT	OUTFLO. LTons
FRPK	0.95	9.1	FREE	0.0	----	----
VOID 8-20	0.95	34.5	FREE	0.0	----	----
Totals		43.6				

INTACT DATA

Draft at AP = 4.290 ft Kmt = 25.329 ft LCG = 54.799A ft-FP
 Draft at FP = 4.290 ft VCG = 12.800 ft LCB = 54.799A ft-FP
 Displacement = 299.5 LTons GMT = 12.529 ft TCG = 0.000 ft-CL

DRAFT/GZ DATA

HEEL degrees	RIGHTING ARM ft	DRAFT AFT ft	DRAFT FWD ft	FLOODED WATER LTons
0.00	0.000	3.347	6.472	43.6
5.00S	0.983	3.292	6.489	44.9
7.00S	1.354	3.240	6.517	45.6
10.00S	1.814	3.113	6.667	46.4
15.00S	2.111	2.713	7.410	49.2
20.00S	1.805	2.140	8.604	51.8
22.00S	1.581	1.888	9.144	52.7
30.00S	0.399	0.685	11.690	55.1
35.00S	-0.450	-0.228	13.600	56.2
40.00S	-1.332	-1.315	15.839	57.1

Note: Drafts are measured at A.P. and F.P along ship's centerline

GZ SUMMARY (Evaluated per IMO (SOLAS'90) Rules for Passenger Ships)

	Available	Required
Static Heel Angle	0.00 deg	7.00 deg
Freeboard to Margin Line	0.874 ft	0.000 ft
Freeboard to Downflooding	3.632 ft	
Angle at Maximum GZ	16.00S deg	
Maximum GZ	2.111 ft	1.300 ft
Range of Positive GZ	32.38 deg	15.00 deg
Gmt (upright damaged)	11.304 ft	
Righting Area (0.00-7.00)	33.044 ft-deg	2.820 ft-deg

**DEPT004A: AUX MACHY
 106' DINNER BOAT**

**Damaged Compartments:
 AUX MACHY**

	DISPLACEMENT LTons	DRAFT AFT ft	DRAFT FWD ft	TRIM ft	HEEL deg.	UPRIGHT GMT ft
INTACT	299.5	4.290	4.290	0.000	0.00	12.529
DAMAGED	360.5	3.739	6.465	2.726F	0.00	9.856

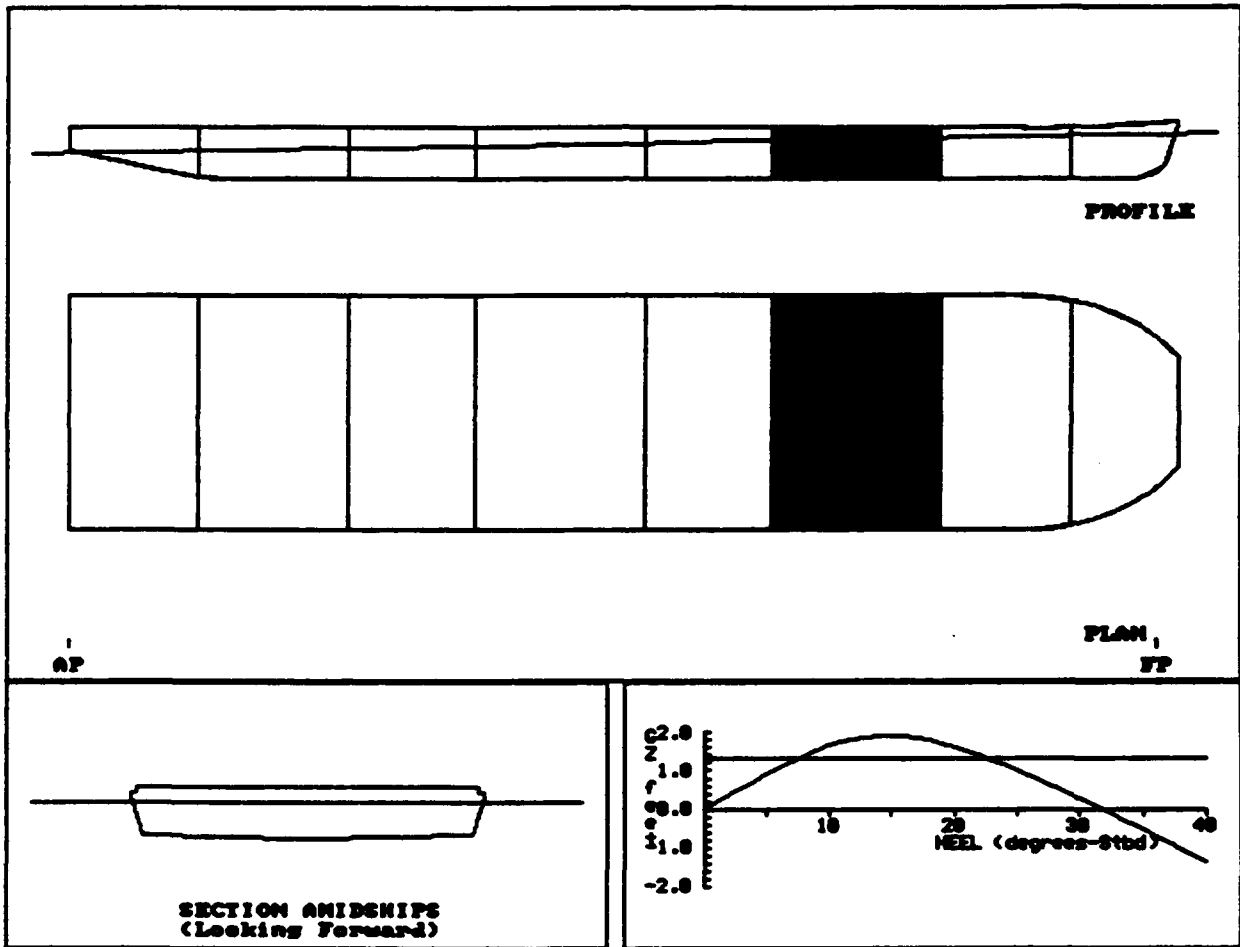

DPRT004A: AUX MACHY
106' DINNER BOAT

COMPARTMENT FLOODING SUMMARY

At 0.0o Heel	PERM.	FLOODED WTR LTons	% FULL (Damaged)	% FULL (Intact)	SP. VOL. ft3/LT	OUTFLOW LTons
AUX MACHY	0.85	61.0	FREE	0.0	----	----
Totals		61.0				

INTACT DATA

Draft at AP = 4.290 ft	KMT = 25.329 ft	LCG = 54.799A ft-FP
Draft at FP = 4.290 ft	VCG = 12.800 ft	LCB = 54.799A ft-FP
Displacement = 299.5 LTons	GMT = 12.529 ft	TCG = 0.000 ft-CL

DRAFT/GZ DATA

HEEL degrees	RIGHTING ARM ft	DRAFT AFT ft	DRAFT FWD ft	FLOODED WATER LTons
0.00	0.000	3.739	6.465	61.0
5.00S	0.909	3.725	6.400	60.6
7.00S	1.242	3.699	6.384	60.5
10.00S	1.649	3.621	6.454	60.0
15.00S	1.915	3.450	6.878	59.4
20.00S	1.630	3.297	7.551	59.1
22.00S	1.414	3.223	7.868	58.9
30.00S	0.282	2.879	9.315	58.7
35.00S	-0.532	2.611	10.395	58.6
40.00S	-1.377	2.298	11.641	58.6

Note: Drafts are measured at A.P. and F.P along ship's centerline

GZ SUMMARY (Evaluated per IMO (SOLAS'90) Rules for Passenger Ships)
Available Required

Static Heel Angle	0.00 deg	7.00 deg
Freeboard to Margin Line	0.787 ft	0.000 ft
Freeboard to Downflooding	3.307 ft	
Angle at Maximum GZ	16.00S deg	
Maximum GZ	1.915 ft	1.300 ft
Range of Positive GZ	31.76 deg	15.00 deg
Gmt (upright damaged)	9.856 ft	
Righting Area (0.00-%.00)	30.031 ft-deg	2.820 ft-deg

DPR005A: VOID 2
 106' DINNER BOAT

Damaged Compartments:
 VOID 36-48

	DISPLACEMENT LTons	DRAFT AFT ft	DRAFT FWD ft	TRIM ft	HEEL deg.	UPRIGHT GMT ft
INTACT	299.5	4.290	4.290	0.000	0.00	12.529
DAMAGED	348.6	4.360	5.455	1.094F	0.00	10.251

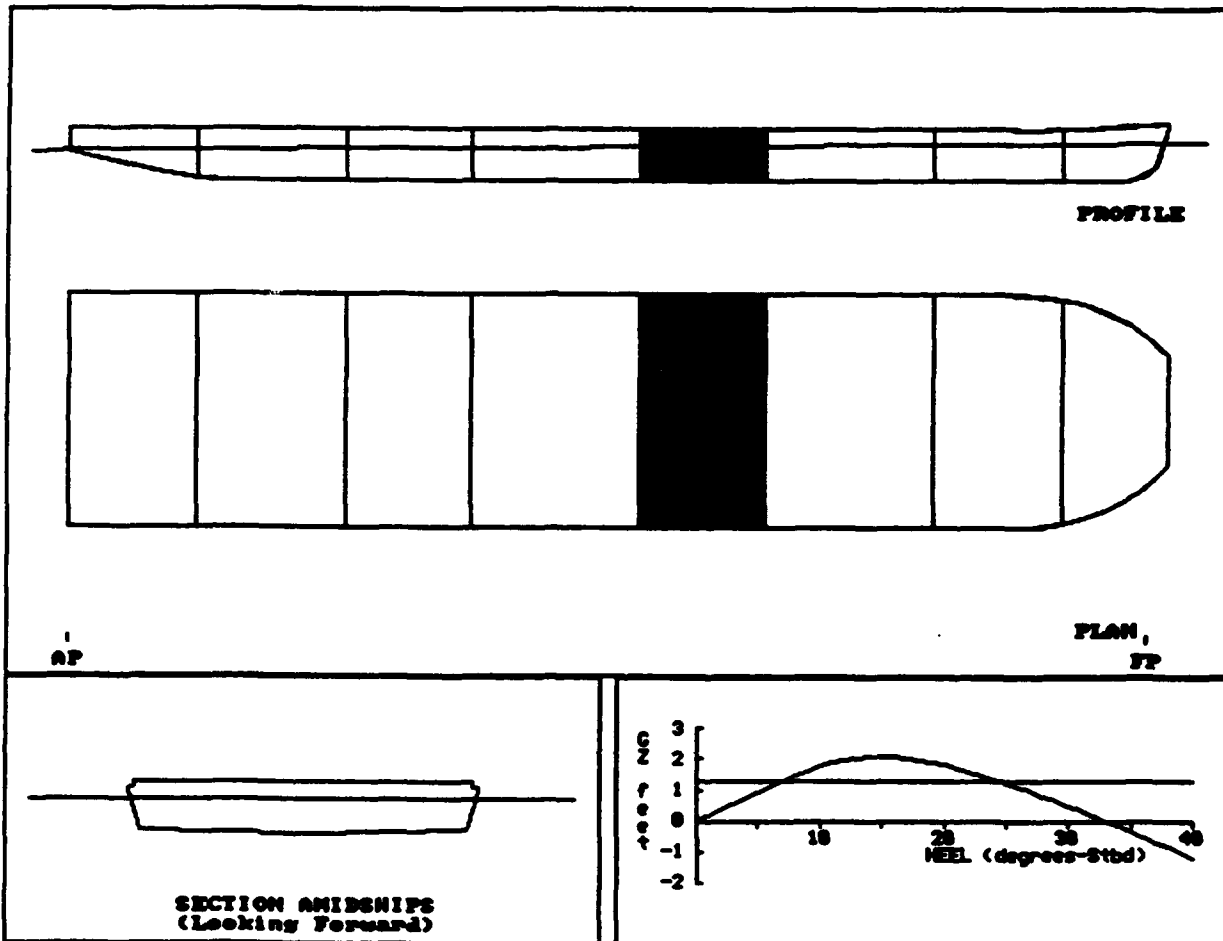

DFRTO05A: VOID 2
106' DINNER BOAT

COMPARTMENT FLOODING SUMMARY

At 0.0o Heel	PERM.	FLOODED WTR LTons	% FULL (Damaged)	% FULL (Intact)	SP.VOL. ft3/LT	OUTFLOW LTons
VOID 36-48	0.95	49.1	FREE	0.0	----	----
Totals		49.1				

INTACT DATA

Draft at AP = 4.290 ft KMT = 25.329 ft LCG = 54.799A ft-FP
 Draft at FP = 4.290 ft VCG = 12.800 ft LCB = 54.799A ft-FP
 Displacement = 299.5 LTons Gmt = 12.529 ft TCG = 0.000 ft-CL

DRAFT/GZ DATA

HEEL degrees	RIGHTING ARM ft	DRAFT AFT ft	DRAFT FWD ft	FLOODED WATER LTons
0.00	0.000	4.360	5.455	49.1
5.00S	0.900	4.345	5.424	49.0
7.00S	1.264	4.334	5.390	48.7
10.00S	1.757	4.304	5.347	48.3
15.00S	2.091	4.309	5.485	47.4
20.00S	1.827	4.442	5.740	46.5
22.00S	1.612	4.494	5.862	46.3
30.00S	0.483	4.749	6.383	45.6
35.00S	-0.333	4.930	6.772	45.3
40.00S	-1.183	5.134	7.223	45.1

Note: Drafts are measured at A.P. and F.P along ship's centerline

GZ SUMMARY (Evaluated per ~~IMO~~ (SOLAS '90) Rules for Passenger Ships)
Available Required

Static Heel Angle	0.00 deg	7.00 deg
Freeboard to Margin Line	1.407 ft	0.000 ft
Freeboard to Downflooding	2.957 ft	
Angle at Maximum GZ	16.00S deg	
Maximum GZ	2.091 ft	1.300 ft
Range of Positive GZ	33.00 deg	15.00 deg
Gmt (upright damaged)	10.251 ft	
Righting Area (0.00-3.00)	32.289 ft-deg	2.820 ft-deg

DPR006A: VOID 3
 106' DINNER BOAT

Imaged Compartments:
 VOID 48-64

	DISPLACEMENT LTons	DRAFT AFT ft	DRAFT FWD ft	TRIM ft	HEEL deg.	UPRIGHT GMT ft
INTACT	299.5	4.290	4.290	0.000	0.00	12.529
DAMAGED	366.1	5.093	5.033	0.059A	0.00	9.460

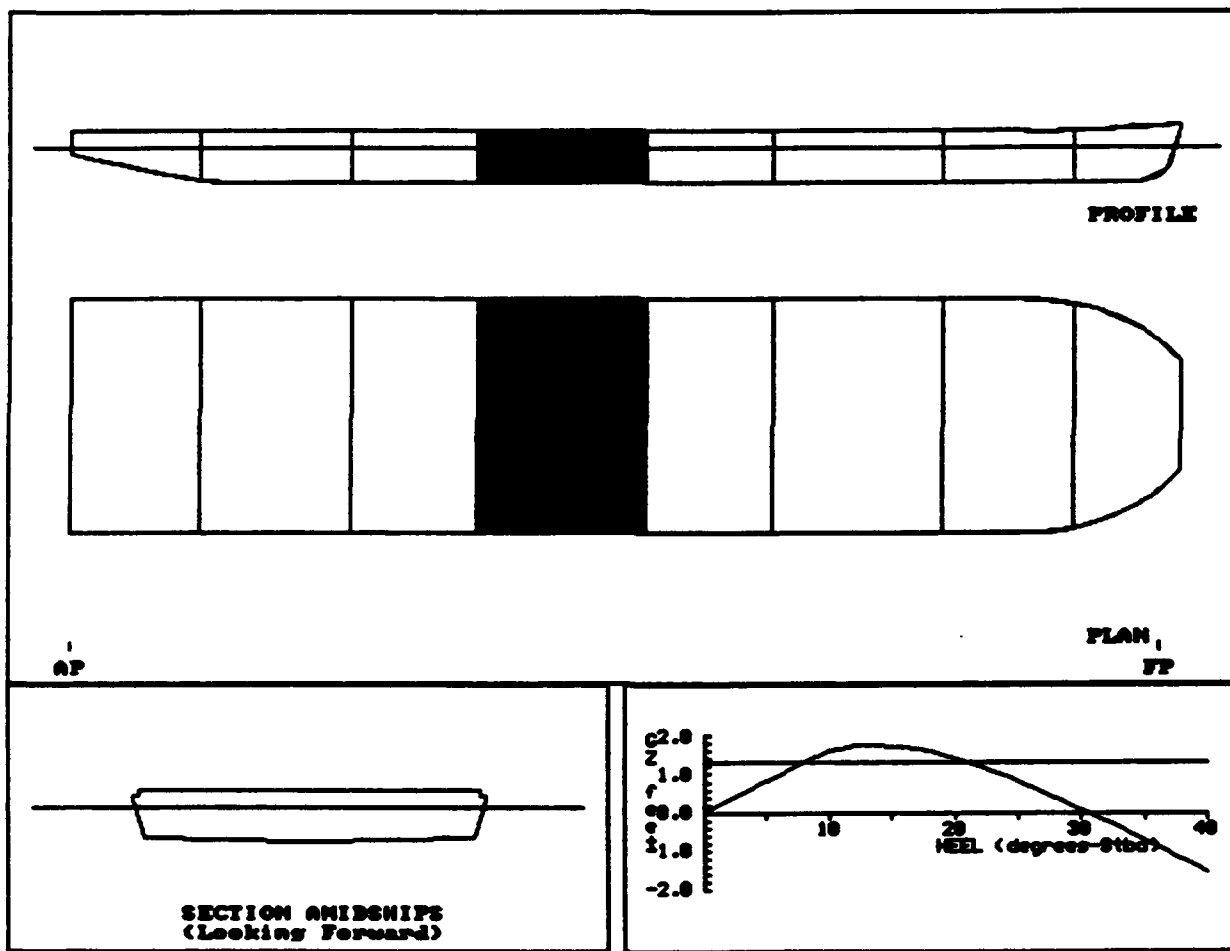

DPRT006A: VOID 3
106' DINNER BOAT

COMPARTMENT FLOODING SUMMARY

At 0.0o Heel	PERM.	FLOODED WTR LTons	% FULL (Damaged)	% FULL (Intact)	SP.VOL. ft3/LT	OUTFLOW LTons
VOID 48-64	0.95	66.5	FREE	0.0	----	----
Totals		66.5				

INTACT DATA

Draft at AP = 4.290 ft	Kmt = 25.329 ft	LCG = 54.799A ft-FP
Draft at FP = 4.290 ft	VCG = 12.800 ft	LCB = 54.799A ft-FP
Displacement = 299.5 LTons	Gmt = 12.529 ft	TCG = 0.000 ft-CL

DRAFT/GZ DATA

HEEL degrees	RIGHTING ARM ft	DRAFT AFT ft	DRAFT FWD ft	FLOODED WATER LTons
0.00	0.000	5.093	5.033	66.5
5.00S	0.831	5.091	4.997	66.5
7.00S	1.157	5.089	4.967	66.2
10.00S	1.601	5.106	4.900	65.9
15.00S	1.743	5.342	4.912	65.0
20.00S	1.429	5.785	5.012	64.1
22.00S	1.211	5.987	5.053	63.9
30.00S	0.091	6.858	5.265	63.2
35.00S	-0.710	7.496	5.412	63.0
40.00S	-1.539	8.216	5.590	62.8

Note: Drafts are measured at A.P. and F.P along ship's centerline

GZ SUMMARY (Evaluated per IMO (SOLAS'90) Rules for Passenger Ships)

	Available	Required
Static Heel Angle	0.00 deg	7.00 deg
Freeboard to Margin Line	1.425 ft	0.000 ft
Freeboard to Downflooding	2.417 ft	
Angle at Maximum GZ	14.00S deg	
Maximum GZ	1.766 ft	1.300 ft
Range of Positive GZ	30.58 deg	15.00 deg
Gmt (upright damaged)	9.460 ft	
Righting Area (0.00-7.00)	27.591 ft-deg	2.820 ft-deg

DPR007A: VOID 4
 106' DINNER BOAT

Damaged Compartments:
 VOID 64-76

	DISPLACEMENT LTons	DRAFT AFT ft	DRAFT FWD ft	TRIM ft	HEEL deg.	UPRIGHT Gmt ft
INTACT	299.5	4.290	4.290	0.000	0.00	12.529
DAMAGED	349.2	5.418	4.217	1.202A	0.00	10.093

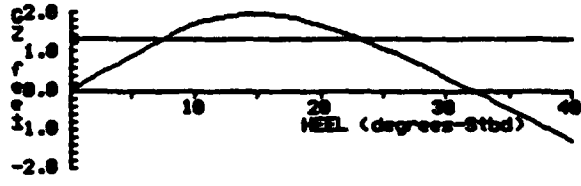
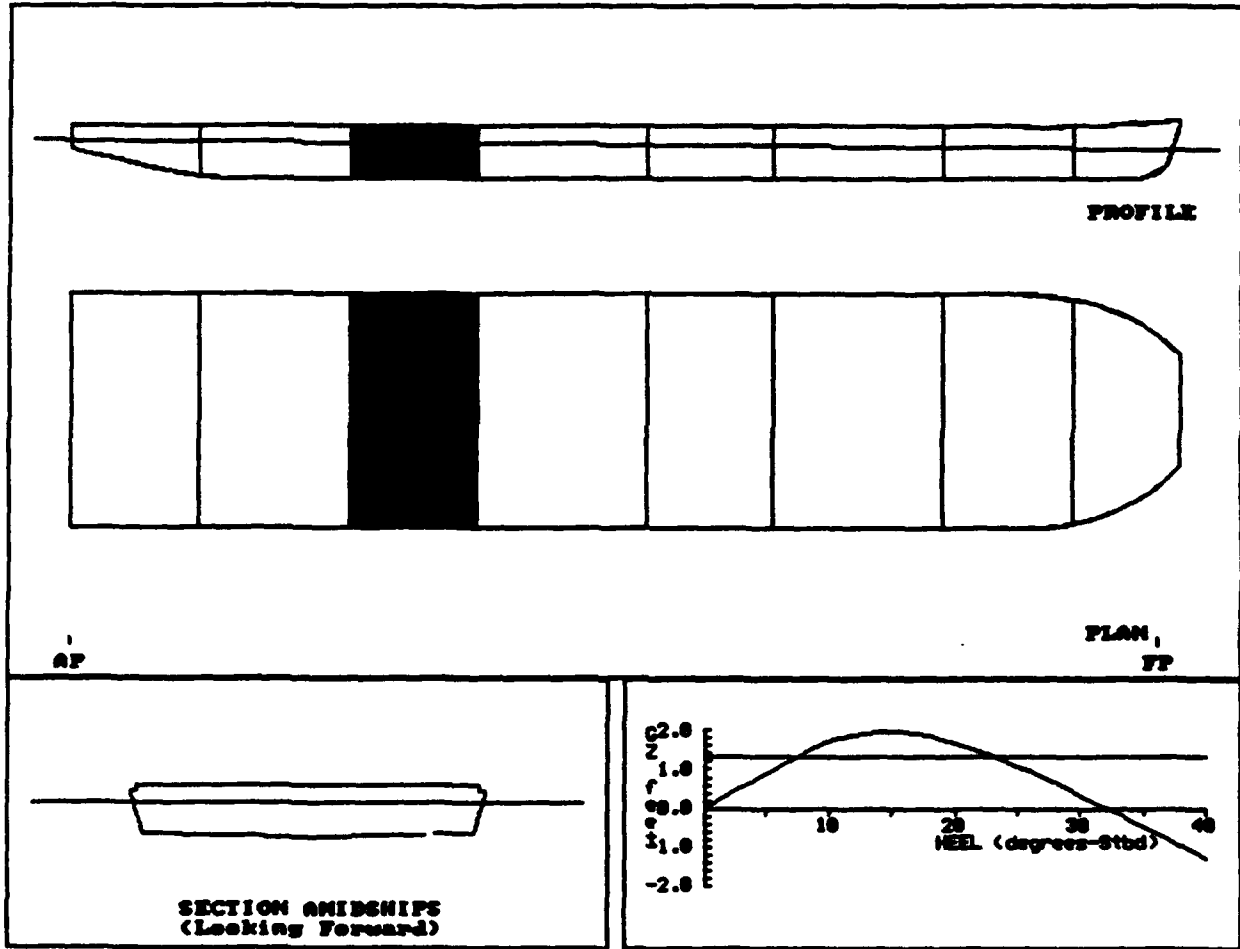

DPRT007A: VOID 4
106' DINNER BOAT

COMPARTMENT FLOODING SUMMARY

At 0.0o Heel	PERM.	FLOODED WTR LTons	% FULL (Damaged)	% FULL (Intact)	SP.VOL. ft3/LT	OUTFLOW LTons
VOID 64-76	0.95	49.6	FREE	0.0	----	----
Totals		49.6				

INTACT DATA

Draft at AP = 4.290 ft	Kmt = 25.329 ft	LCG = 54.799A ft-FP
Draft at FP = 4.290 ft	VCG = 12.800 ft	LCB = 54.799A ft-FP
Displacement = 299.5 LTons	GMT = 12.529 ft	TCG = 0.000 ft-CL

DRAFT/GZ DATA

HEEL degrees	RIGHTING ARM ft	DRAFT AFT ft	DRAFT FWD ft	FLOODED WATER LTons
0.00	0.000	5.418	4.217	49.6
5.00S	0.886	5.423	4.179	49.7
7.00S	1.229	5.420	4.156	49.6
10.00S	1.695	5.462	4.081	49.5
15.00S	1.972	5.802	3.913	49.2
20.00S	1.691	6.376	3.763	48.9
22.00S	1.477	6.640	3.693	48.8
30.00S	0.353	7.793	3.412	48.5
35.00S	-0.458	8.625	3.220	48.5
40.00S	-1.302	9.570	3.009	48.4

Note: Drafts are measured at A.P. and F.P along ship's centerline

STABILITY SUMMARY (Evaluated per IMO (SOLAS'90) Rules for Passenger Ships)
Available Required

Static Heel Angle	0.00 deg	7.00 deg
Freeboard to Margin Line	1.414 ft	0.000 ft
Freeboard to Downflooding	2.282 ft	
Angle at Maximum GZ	16.00S deg	
Maximum GZ	1.972 ft	1.300 ft
Range of Positive GZ	32.21 deg	15.00 deg
Gmt (upright damaged)	10.093 ft	
Righting Area (0.00 to 1.00)	30.690 ft-deg	2.820 ft-deg

DPRT008A: ENGINE RM
 106' DINNER BOAT

Damaged Compartments:
 MACHY

	DISPLACEMENT LTons	DRAFT AFT ft	DRAFT FWD ft	TRIM ft	HEEL deg.	UPRIGHT GMT ft
INTACT	299.5	4.290	4.290	0.000	0.00	12.529
DAMAGED	358.6	6.232	3.476	2.756A	0.00	9.969

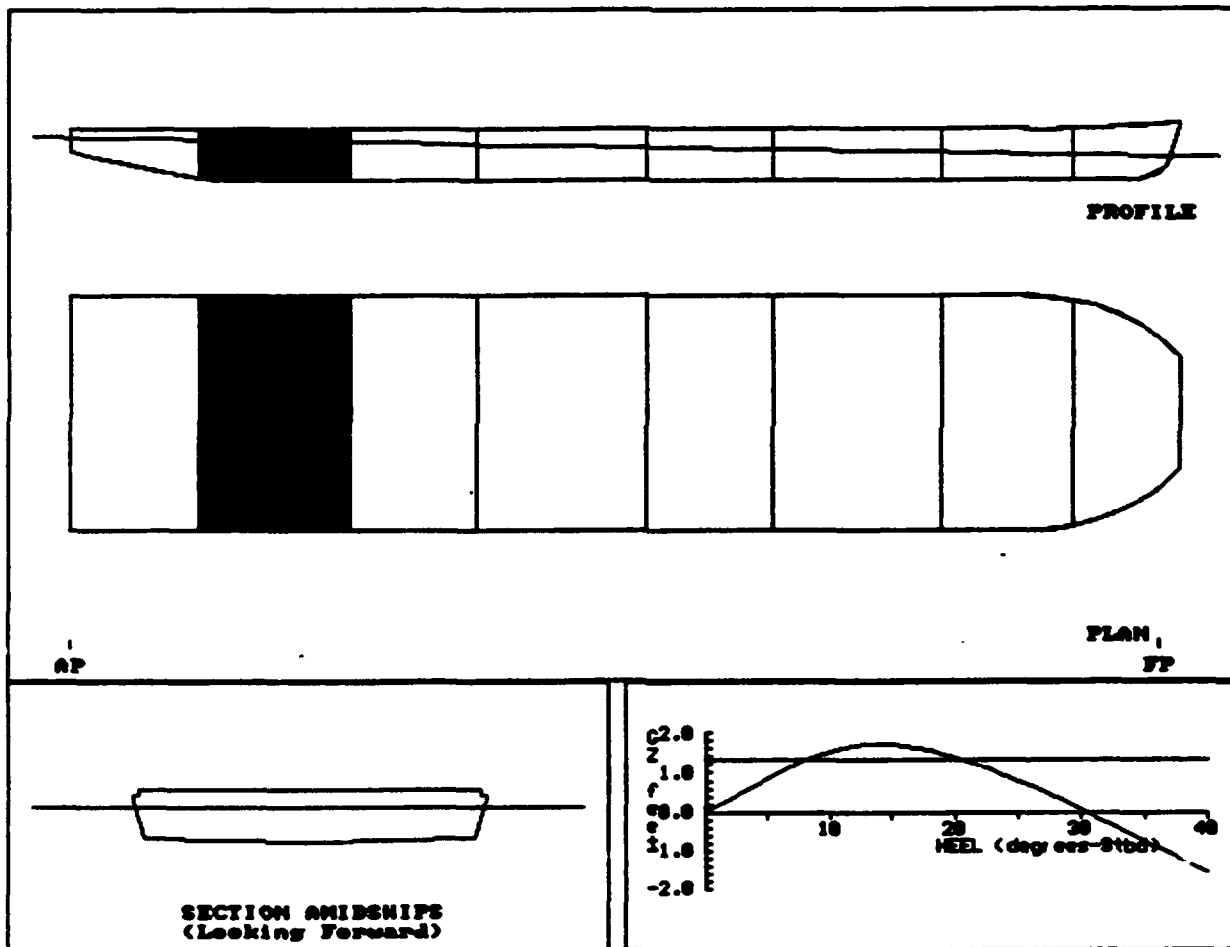

**DPRT008A: ENGINE RM
 106' DINNER BOAT**

COMPARTMENT FLOODING SUMMARY

At 0.0o Heel	PERM.	FLOODED WTR LTons	% FULL (Damaged)	% FULL (Intact)	SP.VOL ft3/LT	OUTFLOW LTons
MACHY	0.85	59.1	FREE	0.0	----	----
Totals		59.1				

INTACT DATA

Draft at AP = 4.290 ft	Kmt = 25.329 ft	LCG = 54.799A ft-FP
Draft at FP = 4.290 ft	VCG = 12.800 ft	LCB = 54.799A ft-FP
Displacement = 299.5 LTons	Gmt = 12.529 ft	TCG = 0.000 ft-CL

DRAFT/GZ DATA

HEEL degrees	RIGHTING ARM ft	DRAFT AFT ft	DRAFT FWD ft	FLOODED WATER LTons
0.00	0.000	6.232	3.476	59.1
5.00S	0.865	6.240	3.440	59.1
7.00S	1.174	6.270	3.403	59.2
10.00S	1.535	6.437	3.269	59.1
15.00S	1.712	7.060	2.919	59.3
20.00S	1.389	7.992	2.502	59.7
22.00S	1.174	8.404	2.330	59.7
30.00S	0.056	10.310	1.530	59.8
35.00S	-0.744	11.695	0.956	59.9
40.00S	-1.573	13.267	0.314	60.0

Note: Drafts are measured at A.P. and F.P along ship's centerline

GZ SUMMARY (Evaluated per IMO (SOLAS'90) Rules for Passenger Ships)

	Available	Required
Static Heel Angle	0.00 deg	7.00 deg
Freeboard to Margin Line	0.891 ft	0.000 ft
Freeboard to Downflooding	1.728 ft	
Angle at Maximum GZ	15.00S deg	
Maximum GZ	1.721 ft	1.300 ft
Range of Positive GZ	30.36 deg	15.00 deg
Gmt (upright damaged)	9.969 ft	
Righting Area (0.00-%7.00)	27.145 ft-deg	2.820 ft-deg

DPR009A: LAZARETTE
 106' DINNER BOAT

Imaged Compartments
 LAZARETTE

	DISPLACEMENT LTons	DRAFT AFT ft	DRAFT FWD ft	TRIM ft	HEEL deg.	UPRIGHT GMT ft
INTACT	299.5	4.290	4.290	0.000	0.00	12.529
DAMAGED	333.9	5.737	3.438	2.299A	0.00	9.661

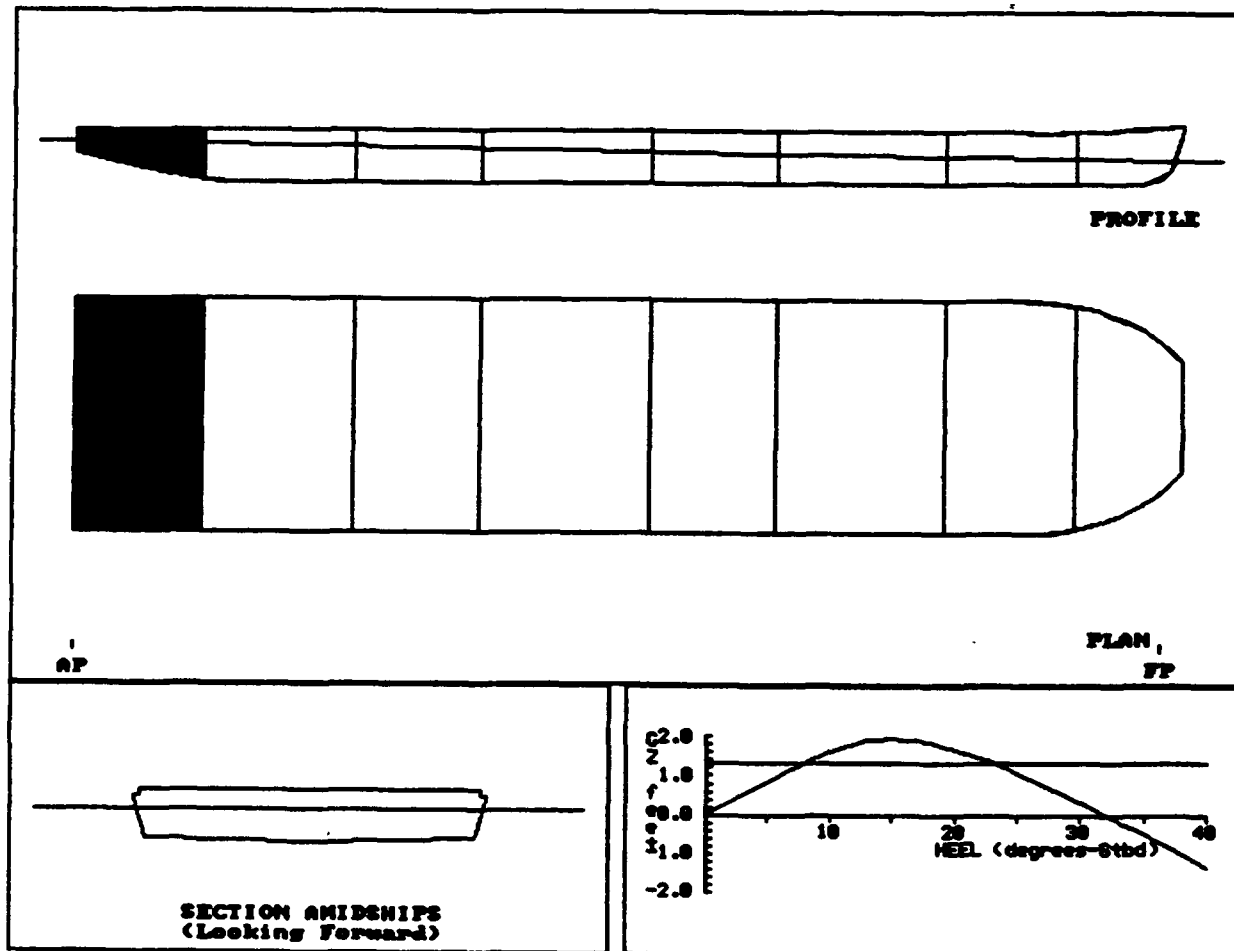

DFRT009A: LASARETTE
106' DINNER BOAT

COMPARTMENT FLOODING SUMMARY

At 0.0o Heel	PERM.	FLOODED WTR LTons	% FULL (Damaged)	% FULL (Intact)	SP.VOL. ft3/LT	OUTFLOW LTons
LAZARETTE	0.95	34.4	FREE	0.0	----	----
Totals		34.4				

INTACT DATA

Draft at AP = 4.290 ft	KMt = 25.329 ft	LCG = 54.799A ft-FP
Draft at FP = 4.290 ft	VCG = 12.800 ft	LCB = 54.799A ft-FP
Displacement = 299.5 LTons	GMT = 12.529 ft	TCG = 0.000 ft-CL

DRAFT/GS DATA

HEEL degrees	RIGHTING ARM ft	DRAFT AFT ft	DRAFT FWD ft	FLOODED WATER LTons
0.00	0.000	5.737	3.438	34.4
5.00S	0.846	5.758	3.388	34.7
7.00S	1.175	5.767	3.358	34.8
10.00S	1.621	5.834	3.269	34.7
15.00S	1.950	5.332	2.918	35.6
20.00S	1.683	4.170	2.446	37.0
22.00S	1.469	3.556	2.228	37.6
30.00S	0.337	9.811	1.301	39.1
35.00S	-0.485	10.582	0.636	39.8
40.00S	-1.342	12.034	-0.117	40.4

Note: Drafts are measured at A.P. and F.P along ship's centerline

GZ SUMMARY (Evaluated per IMO (SOLAS'90) Rules for Passenger Ships)
Available Required

Static Heel Angle	0.00 deg	7.00 deg
Freeboard to Margin Line	1.314 ft	0.000 ft
Freeboard to Downflooding	2.146 ft	
Angle at Maximum GZ	16.00S deg	
Maximum GZ	1.950 ft	1.300 ft
Range of Positive GZ	32.09 deg	15.00 deg
Gmt (upright damaged)	9.661 ft	
Righting Area (0.00-7.00)	29.969 ft-deg	2.820 ft-deg

RTRN001B: FOREPEAK
 106' DINNER BOAT

Damaged Compartments:
 FPK

	DISPLACEMENT LTons	DRAFT AFT ft	DRAFT FWD ft	TRIM ft	HEEL deg.	UPRIGHT Gmt ft
INTACT	295.3	4.240	4.240	0.000	0.00	12.428
DAMAGED	300.1	4.106	4.524	0.417F	0.00	12.084

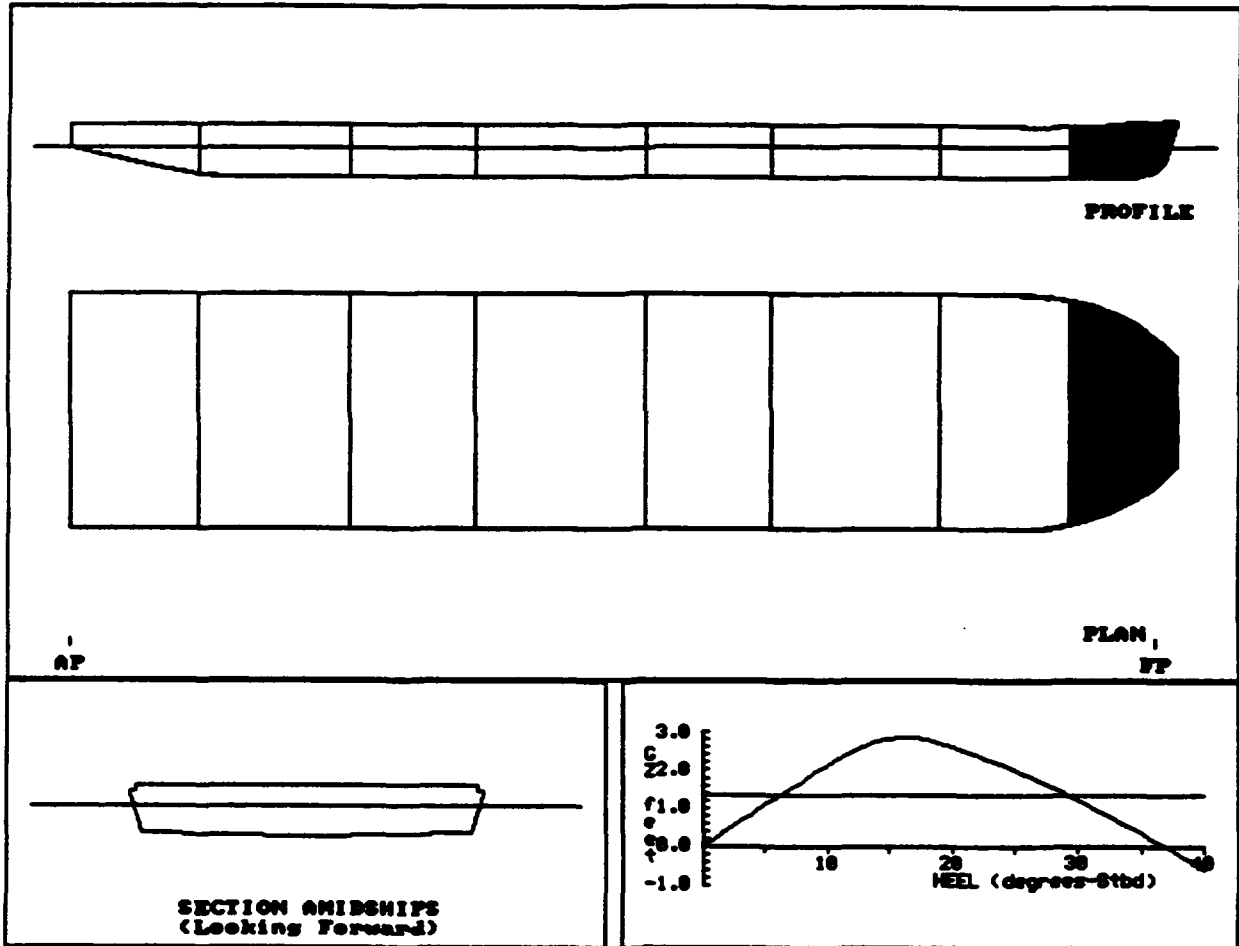

RTRN001B: FOREPEAK
 106' DINNER BOAT

COMPARTMENT FLOODING SUMMARY

At 0.0o Heel	PERM.	FLOODED WTR LTons	% FULL (Damaged)	% FULL (Intact)	SP.VOL. ft3/LT	OUTFLOW LTons
FPK	0.95	4.8	FREE	0.0	----	----
Totals		4.8				

INTACT DATA

Draft at AP = 4.240 ft	KMt = 25.578 ft	LCG = 54.789A ft-FP
Draft at FP = 4.240 ft	VCG = 13.150 ft	LCB = 54.789A ft-FP
Displacement = 295.3 LTons	Gmt = 12.428 ft	TCG = 0.000 ft-CL

DRAFT/GZ DATA

HEEL degrees	RIGHTING ARM ft	DRAFT AFT ft	DRAFT FWD ft	FLOODED WATER LTons
0.00	0.000	4.106	4.524	4.8
5.00S	1.063	4.081	4.508	4.8
7.00S	1.486	4.052	4.498	4.8
10.00S	2.112	4.009	4.459	4.8
15.00S	2.835	3.933	4.452	5.3
20.00S	2.629	3.861	4.552	6.0
22.00S	2.414	3.830	4.606	6.3
30.00S	1.221	3.717	4.847	7.2
35.00S	0.339	3.625	5.050	7.7
40.00S	-0.591	3.504	5.309	8.1

Note: Drafts are measured at A.P. and F.P along ship's centerline

GZ SUMMARY (Evaluated per IMO (SOLAS'90) Rules for Passenger Ships)
 Available Required

Static Heel Angle	0.00 deg	7.00 deg
Freeboard to Margin Line	2.124 ft	0.000 ft
Freeboard to Downflooding	3.324 ft	
Angle at Maximum GZ	17.00S deg	
Maximum GZ	2.863 ft	1.320 ft
Range of Positive GZ	36.84 deg	15.00 deg
Gmt (upright damaged)	12.084 ft	
Righting Area (0.00-7.00)	42.286 ft-deg	2.820 ft-deg

RTRN002B: VOID1
 106' DINNER BOAT

amaged Compartments:
 VOID 8-20

	DISPLACEMENT LTons	DRAFT AFT ft	DRAFT FWD ft	TRIM ft	HEEL deg.	UPRIGHT GMT ft
INTACT	295.3	4.240	4.240	0.000	0.00	12.428
DAMAGED	324.6	3.650	5.674	2.025F	0.00	11.174

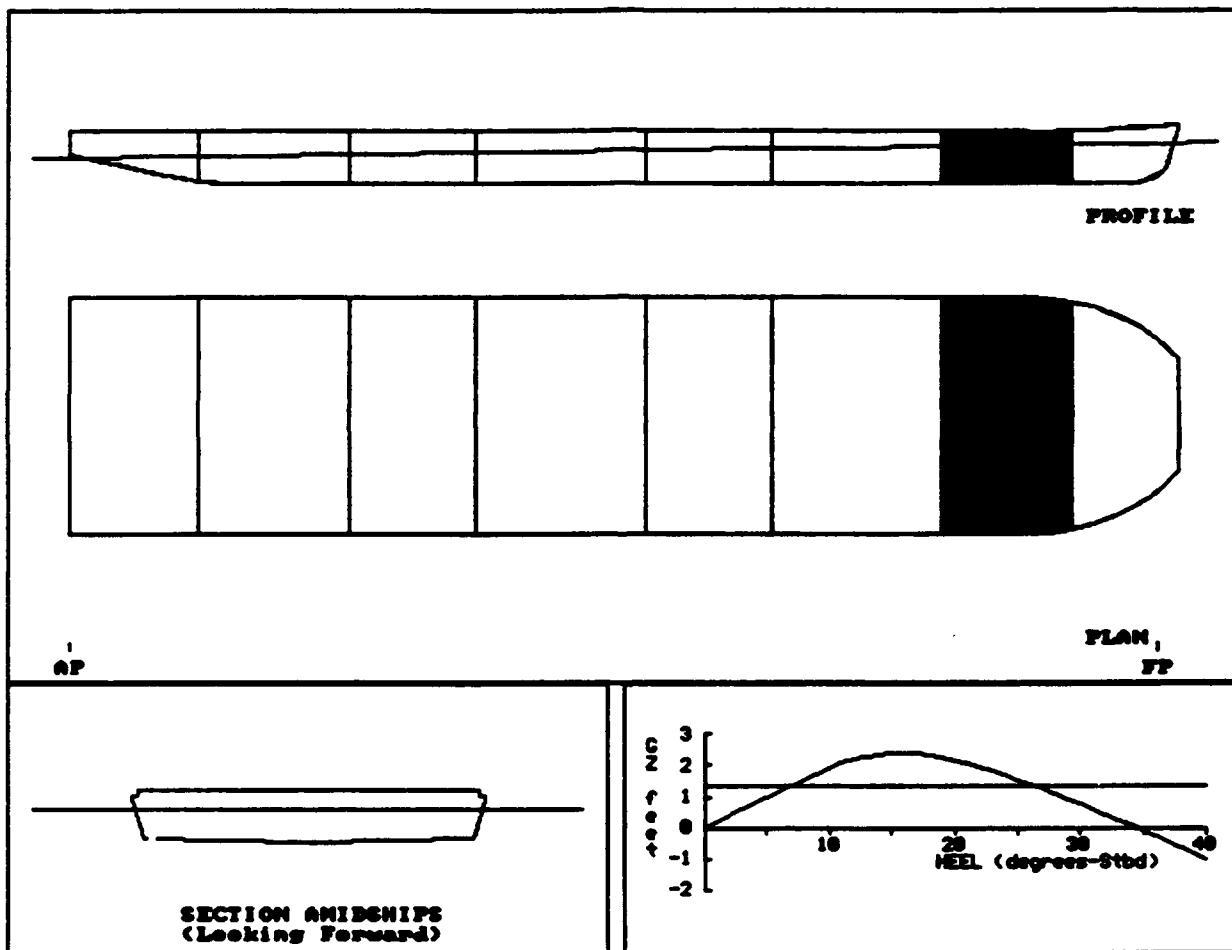

RTRN002B: VOID1
106' DINNER BOAT

COMPARTMENT FLOODING SUMMARY

At 0.0o Heel	PERM.	FLOODED WTR LTons	‡ FULL (Damaged)	‡ FULL (Intact)	SP.VOL. ft3/LT	OUTFLOW LTons
VOID 8-20	0.95	29.4	FREE	0.0	----	----
Totals		29.4				

INTACT DATA

Draft at AP = 4.240 ft	KMT = 25.578 ft	LCG = 54.789A ft-FP
Draft at FP = 4.240 ft	VCG = 13.150 ft	LCB = 54.789A ft-FP
Displacement = 295.3 LTons	GMT = 12.428 ft	TCG = 0.000 ft-CL

DRAFT/GZ DATA

HEEL degrees	RIGHTING ARM ft	DRAFT AFT ft	DRAFT FWD ft	FLOODED WATER LTons
0.00	0.000	3.650	5.674	29.4
5.00S	0.985	3.606	5.678	29.8
7.00S	1.367	3.565	5.683	30.4
10.00S	1.912	3.496	5.694	30.9
15.00S	2.403	3.283	6.000	31.7
20.00S	2.171	3.021	6.547	32.6
22.00S	1.953	2.907	6.792	32.9
30.00S	0.769	2.395	7.906	33.7
35.00S	-0.099	2.007	8.751	34.1
40.00S	-1.007	1.554	9.735	34.4

Note: Drafts are measured at A.P. and F.P along ship's centerline

GZ SUMMARY (Evaluated per IMO (SOLAS'90) Rules for Passenger Ships)
Available Required

Static Heel Angle	0.00 deg	7.00 deg
Freeboard to Margin Line	1.412 ft	0.000 ft
Freeboard to Downflooding	3.513 ft	
Angle at Maximum GZ	17.00S deg	
Maximum GZ	2.409 ft	1.320 ft
Range of Positive GZ	34.45 deg	15.00 deg
Gmt (upright damaged)	11.174 ft	
Righting Area (0.00-‡.00)	36.630 ft-deg	2.820 ft-deg

RTRN003B: FRPK/VOID1
 106' DINNER BOAT

Imaged Compartments:
 FRK VOID 8-20

	DISPLACEMENT LTons	DRAFT AFT ft	DRAFT FWD ft	TRIM ft	HEEL deg.	UPRIGHT GMT ft
INTACT	295.3	4.240	4.240	0.000	0.00	12.428
DAMAGED	338.0	3.307	6.390	3.083F	0.00	11.176

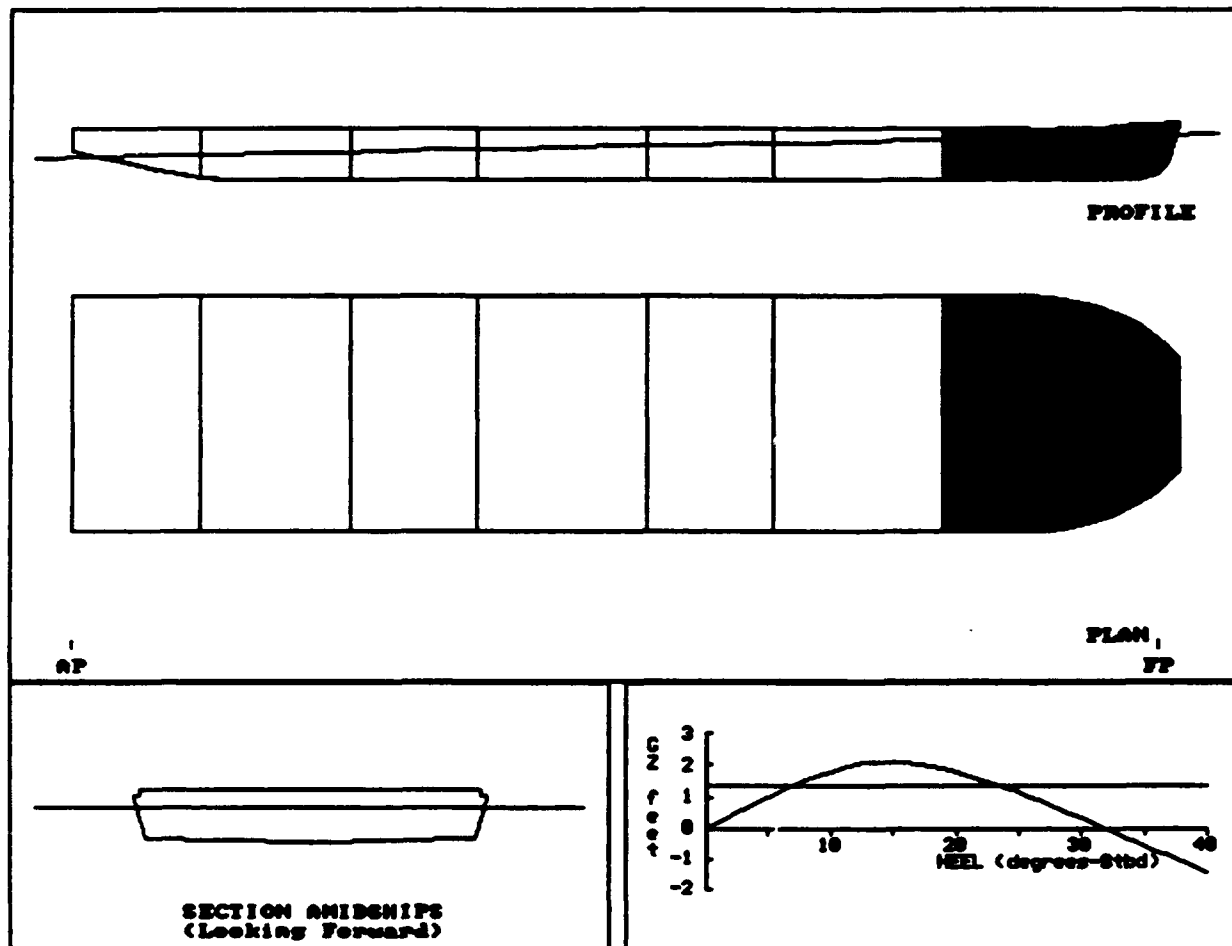

RTRN003B: FRPK/VOID1
106' DINNER BOAT

COMPARTMENT FLOODING SUMMARY

At 0.0o Heel	PERM.	FLOODED WTR LTons	% FULL (Damaged)	% FULL (Intact)	SP.VOL. ft3/LT	OUTFLOW LTons
FPK	0.95	8.9	FREE	0.0	----	----
VOID 8-20	0.95	33.9	FREE	0.0	----	----
Totals		42.8				

INTACT DATA

Draft at AP = 4.240 ft KMT = 25.578 ft LCG = 54.789A ft-FP
 Draft at FP = 4.240 ft VCG = 13.150 ft LCB = 54.789A ft-FP
 Displacement = 295.3 LTons GMT = 12.428 ft TCG = 0.000 ft-CL

DRAFT/GZ DATA

HEEL degrees	RIGHTING ARM ft	DRAFT AFT ft	DRAFT FWD ft	FLOODED WATER LTons
0.00	0.000	3.307	6.390	42.8
5.00S	0.971	3.250	6.409	44.0
7.00S	1.340	3.198	6.434	44.7
10.00S	1.805	3.074	6.571	45.6
15.00S	2.107	2.670	7.284	48.4
20.00S	1.786	2.078	8.453	51.2
22.00S	1.552	1.817	8.982	52.1
30.00S	0.325	0.581	11.470	54.6
35.00S	-0.555	-0.356	13.338	55.7
40.00S	-1.466	-1.471	15.532	56.6

Note: Drafts are measured at A.P. and F.P along ship's centerline

GZ SUMMARY (Evaluated per IMO (SOLAS'90) Rules for Passenger Ships)
Available Required

Static Heel Angle	0.00 deg	7.00 deg
Freeboard to Margin Line	0.945 ft	0.000 ft
Freeboard to Downflooding	3.679 ft	
Angle at Maximum GZ	16.00S deg	
Maximum GZ	2.107 ft	1.320 ft
Range of Positive GZ	31.88 deg	15.00 deg
Gmt (upright damaged)	11.176 ft	
Righting Area (0.00-%.00)	32.827 ft-deg	2.820 ft-deg

RTRN004B: AUX MACHY
 106' DINNER BOAT

Imaged Compartments:
 AUX MACHY

	DISPLACEMENT LTons	DRAFT AFT ft	DRAFT FWD ft	TRIM ft	HEEL deg.	UPRIGHT Gmt ft
INTACT	295.3	4.240	4.240	0.000	0.00	12.428
DAMAGED	355.5	3.690	6.396	2.706F	0.00	9.689

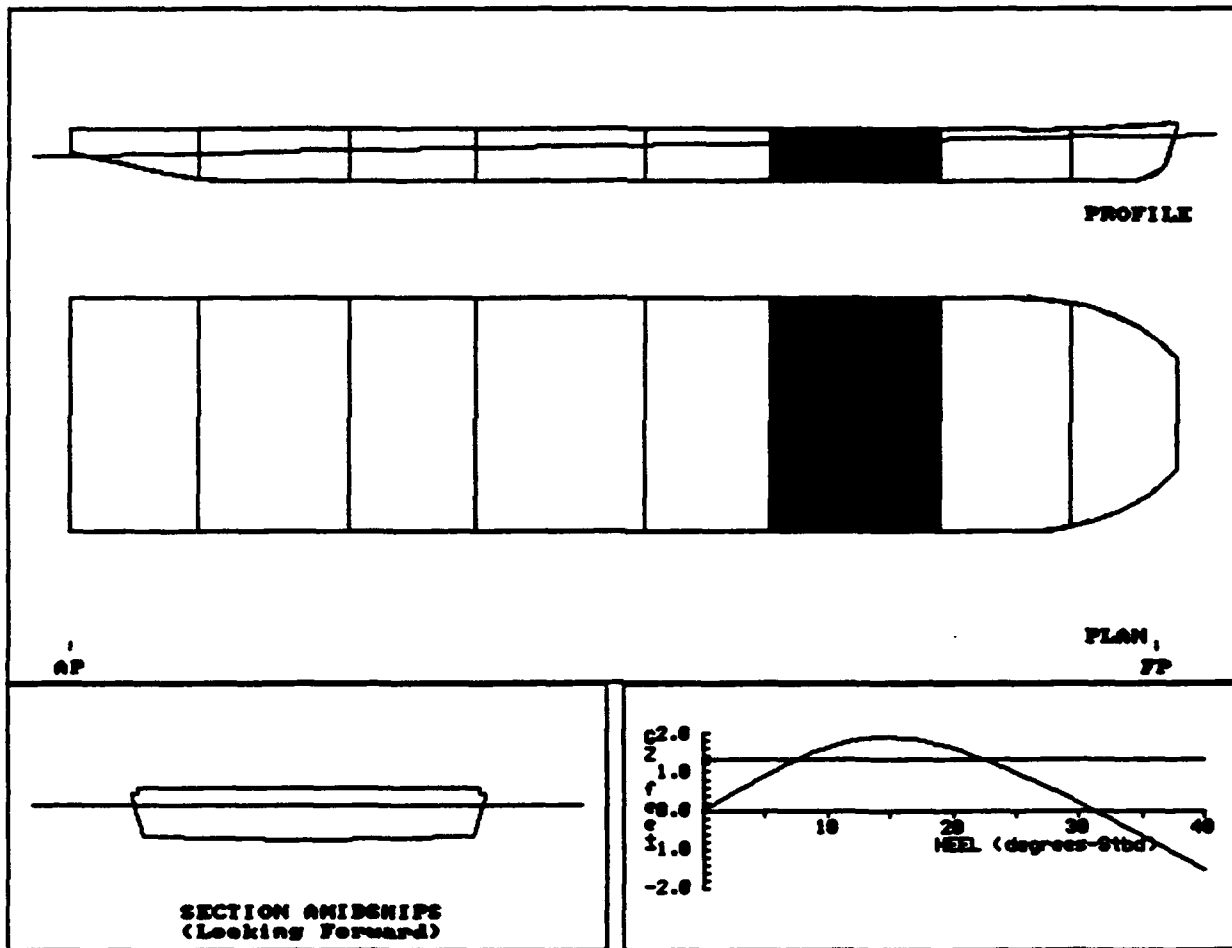

RTRN004B: AUX MACHY
 106' DINNER BOAT

COMPARTMENT FLOODING SUMMARY

At 0.0o Heel	PERM.	FLOODED WTR LTons	% FULL (Damaged)	% FULL (Intact)	SP.VOL. ft ³ /LT	OUTFLOW LTons
AUX MACHY	0.85	60.2	FREE	0.0	----	----
Totals		60.2				

INTACT DATA

Draft at AP = 4.240 ft	KMt = 25.578 ft	LCG = 54.789A ft-FP
Draft at FP = 4.240 ft	VCG = 13.150 ft	LCB = 54.789A ft-FP
Displacement = 295.3 LTons	GMT = 12.428 ft	TCG = 0.000 ft-CL

DRAFT/GZ DATA

HEEL degrees	RIGHTING ARM ft	DRAFT AFT ft	DRAFT FWD ft	FLOODED WATER LTons
0.00	0.000	3.690	6.396	60.2
5.00S	0.892	3.673	6.337	59.9
7.00S	1.224	3.648	6.316	59.7
10.00S	1.634	3.571	6.374	59.3
15.00S	1.908	3.391	6.774	58.7
20.00S	1.607	3.216	7.423	58.3
22.00S	1.381	3.134	7.727	58.2
30.00S	0.204	2.754	9.113	57.9
35.00S	-0.639	2.462	10.149	57.8
40.00S	-1.514	2.122	11.344	57.8

Note: Drafts are measured at A.P. and F.P along ship's centerline

GZ SUMMARY (Evaluated per IMO (SOLAS'90) Rules for Passenger Ships)

	Available	Required
Static Heel Angle	0.00 deg	7.00 deg
Freeboard to Margin Line	0.851 ft	0.000 ft
Freeboard to Downflooding	3.359 ft	
Angle at Maximum GZ	16.00S deg	
Maximum GZ	1.908 ft	1.320 ft
Range of Positive GZ	31.24 deg	15.00 deg
Gmt (upright damaged)	9.689 ft	
Righting Area (0.00-7.00)	29.727 ft-deg	2.820 ft-deg

RTRN005B: VOID 2
 106' DINNER BOAT

Damaged Compartments:
 VOID 36-48

	DISPLACEMENT LTons	DRAFT AFT ft	DRAFT FWD ft	TRIM ft	HEEL deg.	UPRIGHT GMT ft
INTACT	295.3	4.240	4.240	0.000	0.00	12.428
DAMAGED	343.7	4.308	5.394	1.086F	0.00	10.076

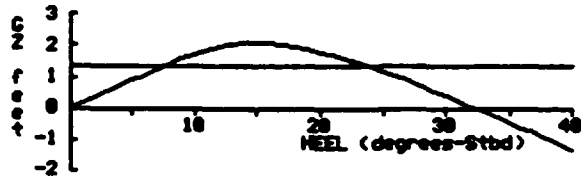
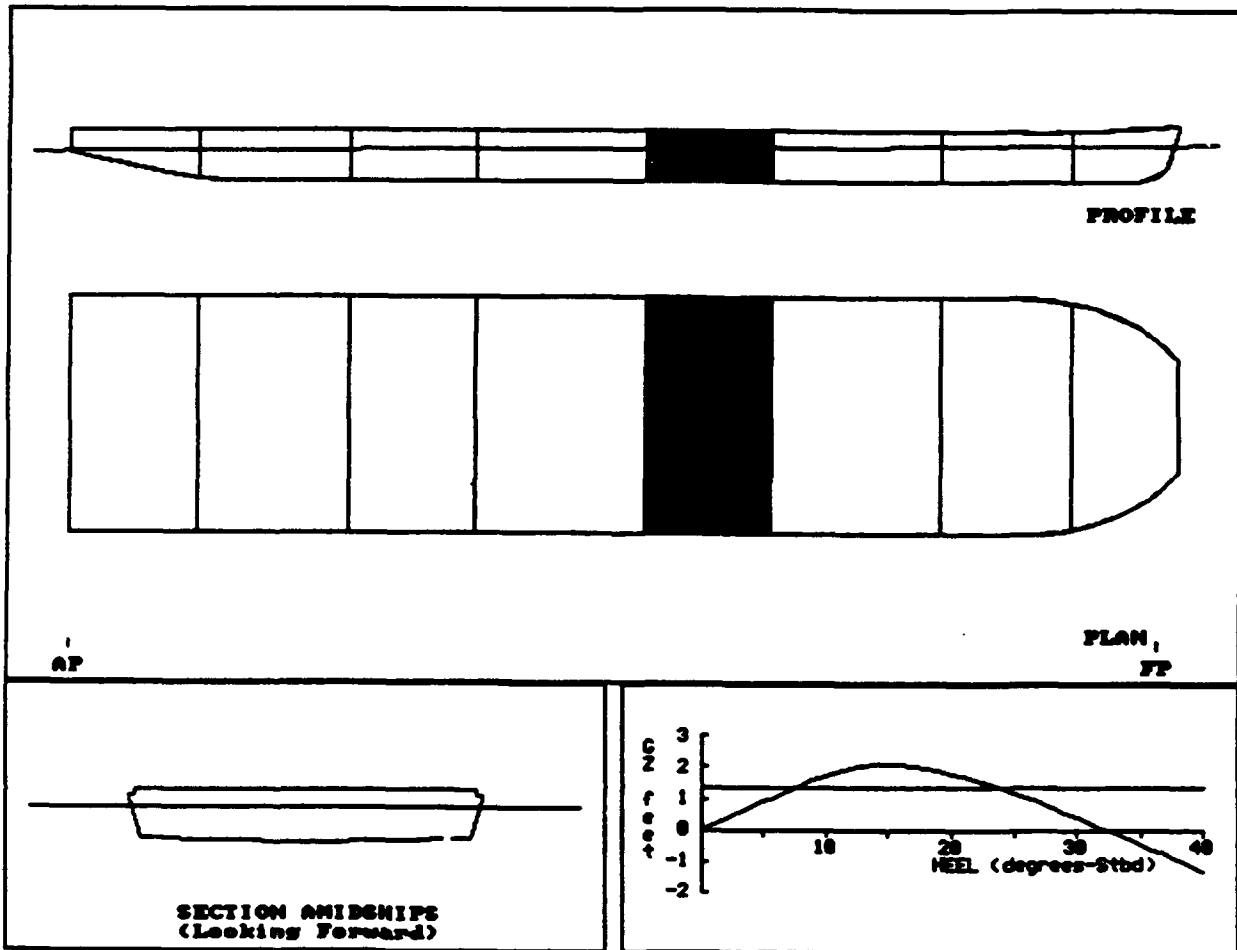

RTRN005B: VOID 2
 106' DINNER BOAT

COMPARTMENT FLOODING SUMMARY

At 0.0o Heel	PERM.	FLOODED WTR LTons	‡ FULL (Damaged)	‡ FULL (Intact)	SP.VOL. ft3/LT	OUTFLOW LTons
VOID 36-48	0.95	48.5	FREE	0.0	----	----
Totals		48.5				

INTACT DATA

Draft at AP = 4.240 ft	KMt = 25.578 ft	LCG = 54.789A ft-FP
Draft at FP = 4.240 ft	VCG = 13.150 ft	LCB = 54.789A ft-FP
Displacement = 295.3 LTons	Gmt = 12.428 ft	TCG = 0.000 ft-CL

DRAFT/GZ DATA

HEEL degrees	RIGHTING ARM ft	DRAFT AFT ft	DRAFT FWD ft	FLOODED WATER LTons
0.00	0.000	4.308	5.394	48.5
5.00S	0.884	4.291	5.366	48.4
7.00S	1.243	4.277	5.333	48.1
10.00S	1.735	4.247	5.287	47.7
15.00S	2.085	4.236	5.411	46.8
20.00S	1.801	4.328	5.667	46.0
22.00S	1.577	4.380	5.766	45.7
30.00S	0.403	4.586	6.254	45.0
35.00S	-0.443	4.718	6.635	44.7
40.00S	-1.323	4.880	7.060	44.5

Note: Drafts are measured at A.P. and F.P along ship's centerline

GZ SUMMARY (Evaluated per IMO (SOLAS'90) Rules for Passenger Ships)
 Available Required

Static Heel Angle	0.00 deg	7.00 deg
Freeboard to Margin Line	1.465 ft	0.000 ft
Freeboard to Downflooding	3.011 ft	
Angle at Maximum GZ	16.00S deg	
Maximum GZ	2.085 ft	1.320 ft
Range of Positive GZ	32.42 deg	15.00 deg
Gmt (upright damaged)	10.076 ft	
Righting Area (0.00-‡.00)	31.949 ft-deg	2.820 ft-deg

RTRN006B: VOID 3
 106' DINNER BOAT

Imaged Compartments:
 VOID 48-64

	DISPLACEMENT LTons	DRAFT AFT ft	DRAFT FWD ft	TRIM ft	HEEL deg.	UPRIGHT Gmt ft
INTACT	295.3	4.240	4.240	0.000	0.00	12.428
DAMAGED	361.0	5.032	4.976	0.056A	0.00	9.298

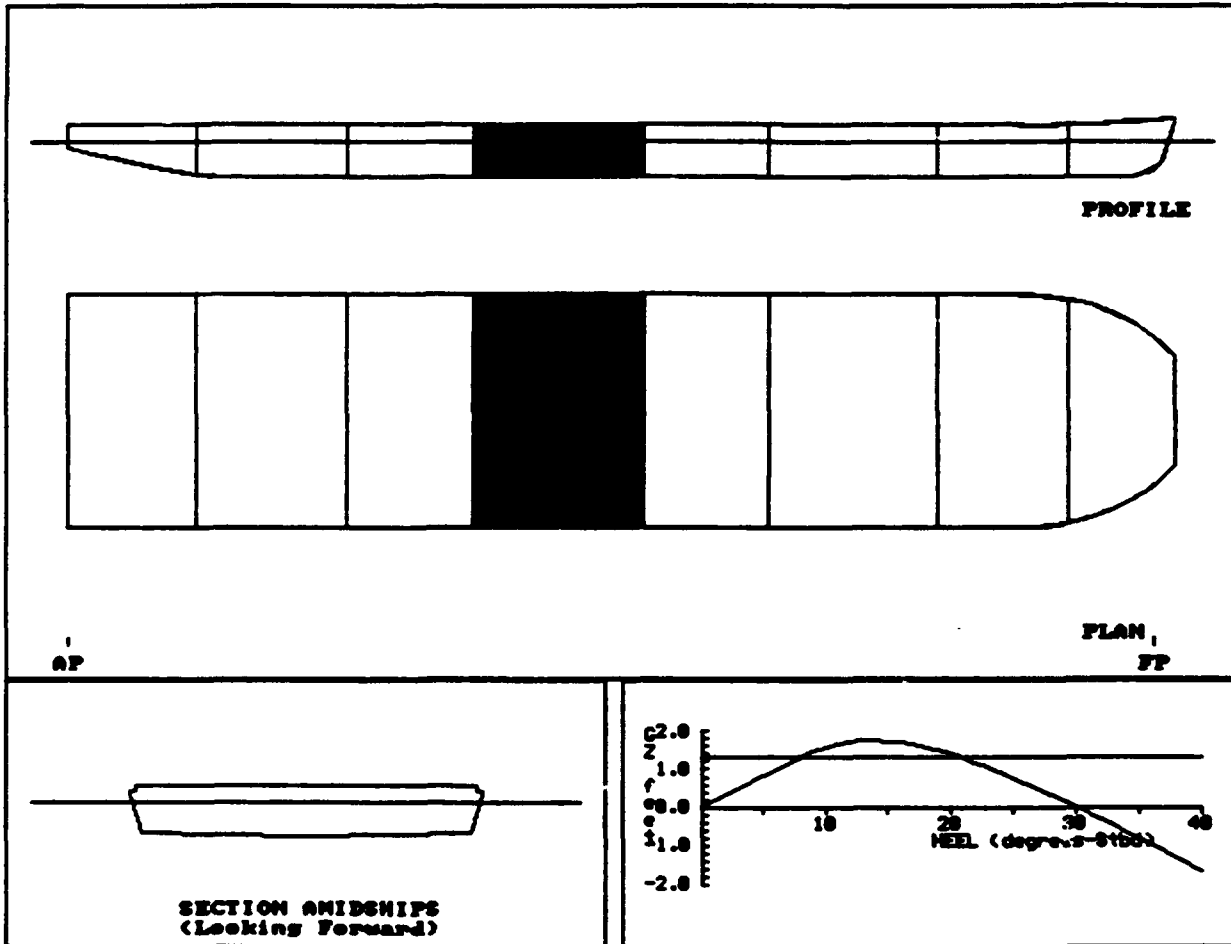

RTRN006B: VOID 3
 106' DINNER BOAT

COMPARTMENT FLOODING SUMMARY

At 0.0o Heel	PERM.	FLOODED WTR LTons	% FULL (Damaged)	% FULL (Intact)	SP.VOL. ft3/LT	OUTFLOW LTons
VOID 48-64	0.95	65.7	FREE	0.0	----	----
Totals		65.7				

INTACT DATA

Draft at AP = 4.240 ft	KMt = 25.578 ft	LCG = 54.789A ft-FP
Draft at FP = 4.240 ft	VCG = 13.150 ft	LCB = 54.789A ft-FP
Displacement = 295.3 LTons	GMT = 12.428 ft	TCG = 0.000 ft-CL

DRAFT/GZ DATA

HEEL degrees	RIGHTING ARM ft	DRAFT AFT ft	DRAFT FWD ft	FLOODED WATER LTons
0.00	0.000	5.032	4.976	65.7
5.00S	0.816	5.030	4.942	65.6
7.00S	1.138	5.026	4.912	65.4
10.00S	1.585	5.036	4.844	65.0
15.00S	1.742	5.249	4.848	64.2
20.00S	1.413	5.665	4.932	63.3
22.00S	1.184	5.854	4.967	63.0
30.00S	0.018	6.665	5.151	62.4
35.00S	-0.812	7.261	5.279	62.1
40.00S	-1.670	7.933	5.437	61.9

Note: Drafts are measured at A.P. and F.P along ship's centerline

GZ SUMMARY (Evaluated per IMO (SOLAS'90) Rules for Passenger Ships)

	Available	Required
Static Heel Angle	0.00 deg	7.00 deg
Freeboard to Margin Line	1.484 ft	0.000 ft
Freeboard to Downflooding	2.477 ft	
Angle at Maximum GZ	15.00S deg	
Maximum GZ	1.761 ft	1.320 ft
Range of Positive GZ	30.11 deg	15.00 deg
Gmt (upright damaged)	9.298 ft	
Righting Area (0.00-%.00)	27.350 ft-deg	2.820 ft-deg

RTRM007B: VOID 4
 106' DINNER BOAT

Imaged Compartments:
 VOID 64-76

	DISPLACEMENT LTons	DRAFT AFT ft	DRAFT FWD ft	TRIM ft	HEEL deg.	UPRIGHT GMT ft
INTACT	295.3	4.240	4.240	0.000	0.00	12.428
DAMAGED	344.3	5.355	4.167	1.188A	0.00	9.945

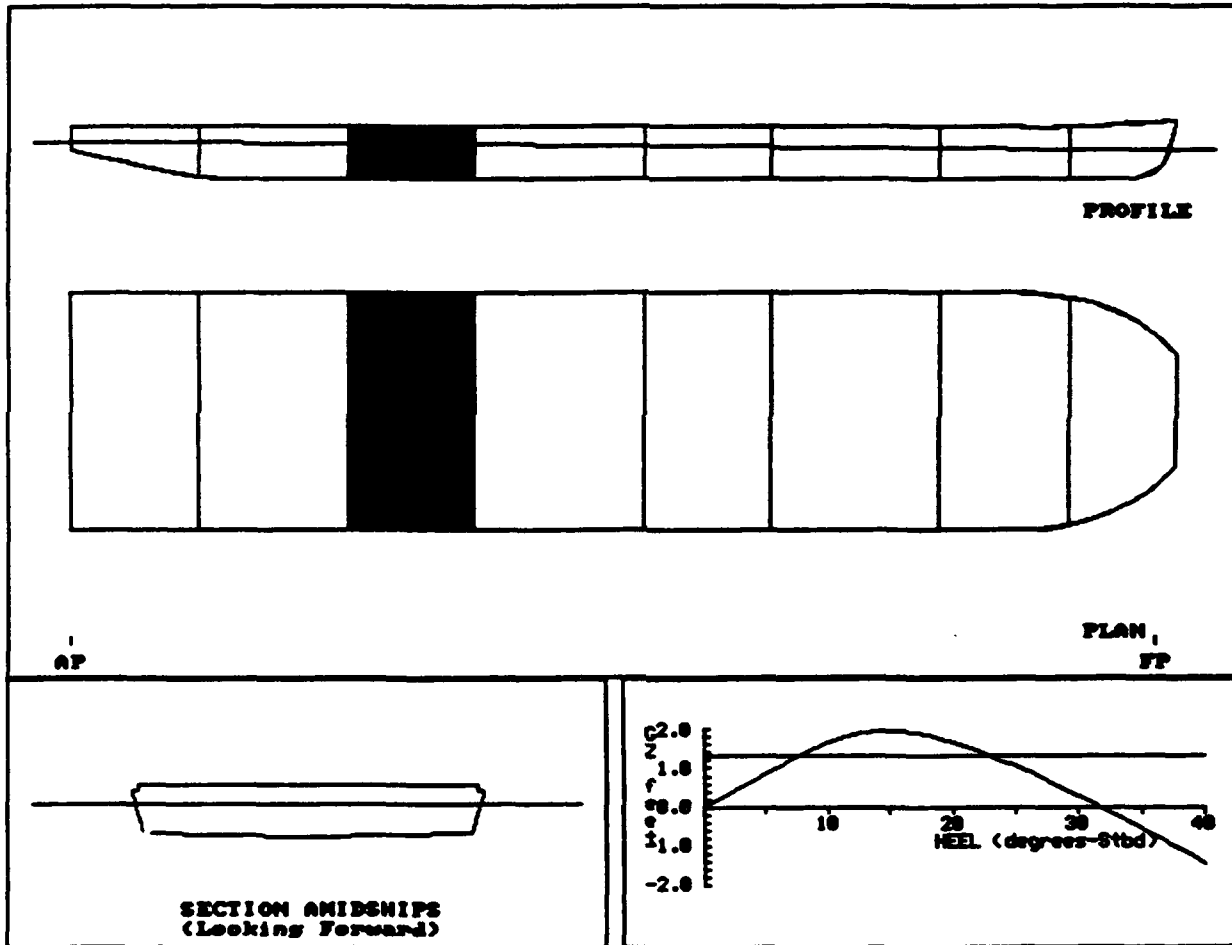

RTRN007B: VOID 4
106' DINNER BOAT

COMPARTMENT FLOODING SUMMARY

At 0.0o Heel	PERM.	FLOODED WTR LTons	% FULL (Damaged)	% FULL (Intact)	SP.VOL. ft3/LT	OUTFLOW LTons
VOID 64-76	0.95	49.0	FREE	0.0	----	----
Totals		49.0				

INTACT DATA

Draft at AP = 4.240 ft	Kmt = 25.578 ft	LCG = 54.789A ft-FP
Draft at FP = 4.240 ft	VCG = 13.150 ft	LCB = 54.789A ft-FP
Displacement = 295.3 LTons	GMT = 12.428 ft	TCG = 0.000 ft-CL

DRAFT/GZ DATA

HEEL degrees	RIGHTING ARM ft	DRAFT AFT ft	DRAFT FWD ft	FLOODED WATER LTons
0.00	0.000	5.355	4.167	49.0
5.00S	0.873	5.360	4.129	49.0
7.00S	1.213	5.355	4.107	49.0
10.00S	1.679	5.388	4.036	48.9
15.00S	1.970	5.703	3.864	48.6
20.00S	1.673	6.248	3.702	48.2
22.00S	1.449	6.497	3.627	48.1
30.00S	0.280	7.585	3.327	47.9
35.00S	-0.561	8.371	3.122	47.8
40.00S	-1.434	9.263	2.897	47.7

Note: Drafts are measured at A.P. and F.P along ship's centerline

GZ SUMMARY (Evaluated per IMO (SOLAS'90) Rules for Passenger Ships)
Available Required

Static Heel Angle	0.00 deg	7.00 deg
Freeboard to Margin Line	1.474 ft	0.000 ft
Freeboard to Downflooding	2.343 ft	
Angle at Maximum GZ	16.00S deg	
Maximum GZ	1.970 ft	1.320 ft
Range of Positive GZ	31.70 deg	15.00 deg
Gmt (upright damaged)	9.945 ft	
Righting Area (0.00-7.00)	30.453 ft-deg	2.820 ft-deg

RTRN008B: ENGINE RM
 106' DINNER BOAT

Imaged Compartments:
 MACNY

	DISPLACEMENT LTons	DRAFT AFT ft	DRAFT FWD ft	TRIM ft	HEEL deg.	UPRIGHT GMT ft
INTACT	295.3	4.240	4.240	0.000	0.00	12.428
DAMAGED	353.6	6.161	3.432	2.729A	0.00	9.818

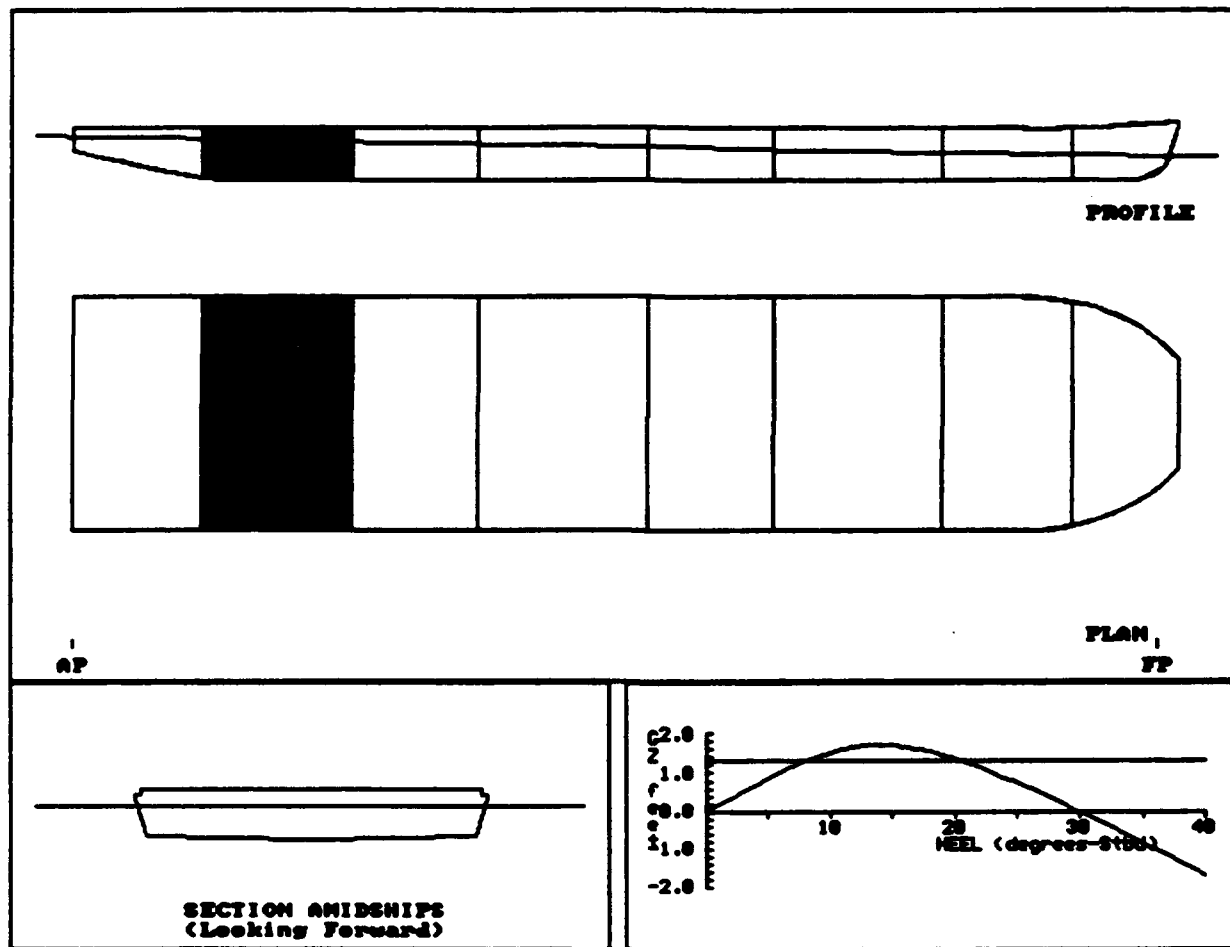

RTRN008B: ENGINE RM
 106' DINNER BOAT

COMPARTMENT FLOODING SUMMARY

At 0.0o Heel	PERM.	FLOODED WTR LTons	% FULL (Damaged)	% FULL (Intact)	SP.VOL. ft3/LT	OUTFLOW LTons
MACHY	0.85	58.3	FREE	0.0	----	----
Totals		58.3				

INTACT DATA

Draft at AP = 4.240 ft	KMt = 25.578 ft	LCG = 54.789A ft-FP
Draft at FP = 4.240 ft	VCG = 13.150 ft	LCB = 54.789A ft-FP
Displacement = 295.3 LTons	GMT = 12.428 ft	TCG = 0.000 ft-CL

DRAFT/GZ DATA

HEEL degrees	RIGHTING ARM ft	DRAFT AFT ft	DRAFT FWD ft	FLOODED WATER LTons
0.00	0.000	6.161	3.432	58.3
5.00S	0.854	6.168	3.397	58.3
7.00S	1.164	6.192	3.362	58.4
10.00S	1.532	6.327	3.249	58.3
15.00S	1.714	6.936	2.885	58.5
20.00S	1.378	7.836	2.457	58.9
22.00S	1.153	8.234	2.282	58.9
30.00S	-0.010	10.069	1.467	59.0
35.00S	-0.840	11.401	0.884	59.0
40.00S	-1.699	12.914	0.231	59.1

Note: Drafts are measured at A.P. and F.P along ship's centerline

GZ SUMMARY (Evaluated per IMO (SOLAS'90) Rules for Passenger Ships)

	Available	Required
Static Heel Angle	0.00 deg	7.00 deg
Freeboard to Margin Line	0.957 ft	0.000 ft
Freeboard to Downflooding	1.794 ft	
Angle at Maximum GZ	15.00S deg	
Maximum GZ	1.723 ft	1.320 ft
Range of Positive GZ	29.94 deg	15.00 deg
Gmt (upright damaged)	9.818 ft	
Righting Area (0.00-7.00)	27.027 ft-deg	2.820 ft-deg

RTRN009B: LAZARETTE
 106' DINNER BOAT

Imaged Compartments:
 LAZARETTE

	DISPLACEMENT LTons	DRAFT AFT ft	DRAFT FWD ft	TRIM ft	HEEL deg.	UPRIGHT GMT ft
INTACT	295.3	4.240	4.240	0.000	0.00	12.428
DAMAGED	328.8	5.653	3.407	2.246A	0.00	9.514

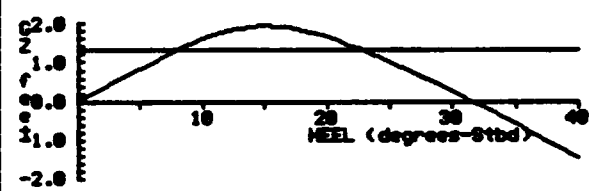
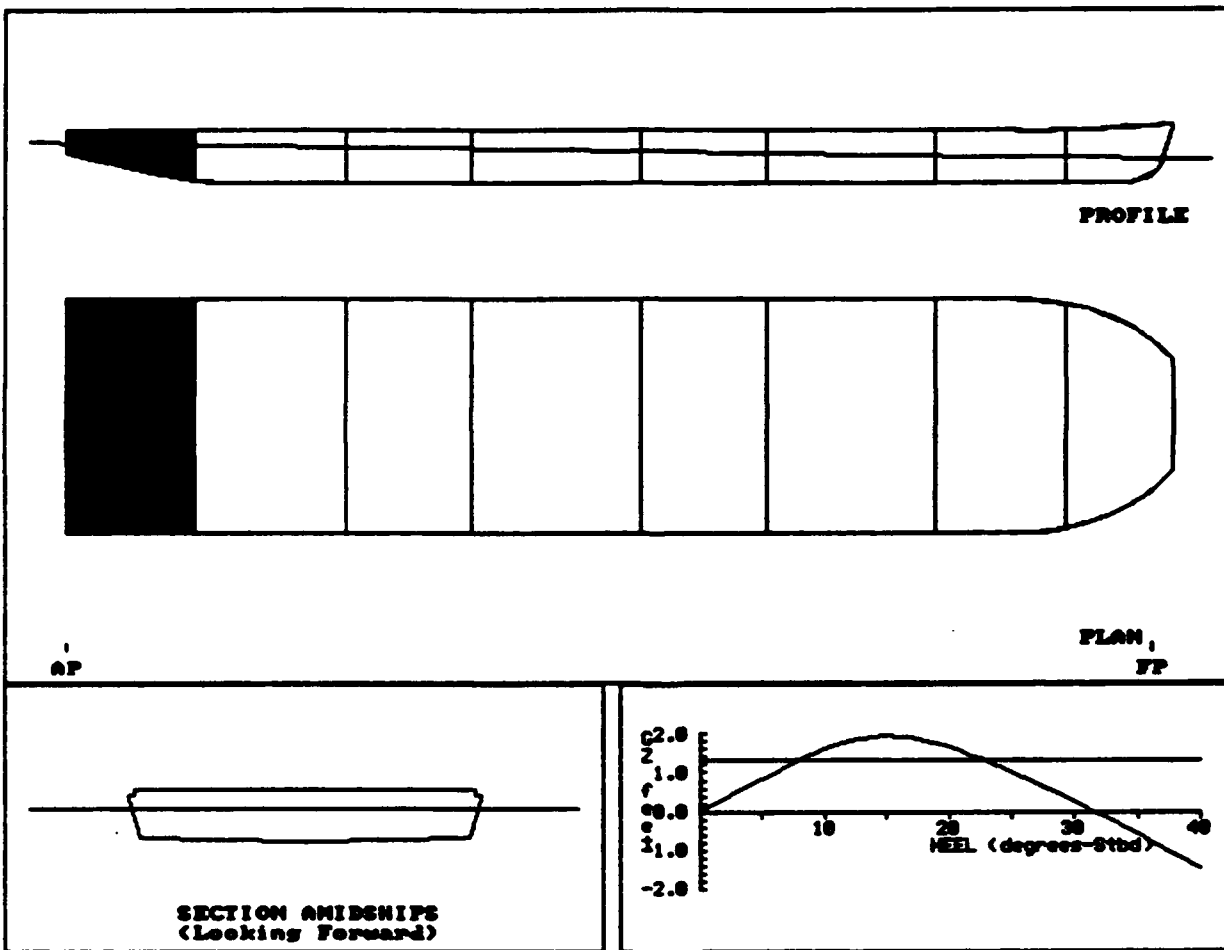

RTRN009B: LAZARETTE
106' DINNER BOAT

COMPARTMENT FLOODING SUMMARY

At 0.0o Heel	PERM.	FLOODED WTR LTons	% FULL (Damaged)	% FULL (Intact)	SP.VOL. ft3/LT	OUTFLOW LTons
LAZARETTE	0.95	33.6	FREE	0.0	----	----
Totals		33.6				

INTACT DATA

Draft at AP = 4.240 ft	Kmt = 25.578 ft	LCG = 54.789A ft-FP
Draft at FP = 4.240 ft	VCG = 13.150 ft	LCB = 54.789A ft-FP
Displacement = 295.3 LTons	GMT = 12.428 ft	TCG = 0.000 ft-CL

DRAFT/GZ DATA

HEEL degrees	RIGHTING ARM ft	DRAFT AFT ft	DRAFT FWD ft	FLOODED WATER LTons
0.00	0.000	5.653	3.407	33.6
5.00S	0.835	5.673	3.357	33.9
7.00S	1.160	5.681	3.327	34.0
10.00S	1.608	5.741	3.240	34.0
15.00S	1.946	6.209	2.891	34.9
20.00S	1.665	7.019	2.408	36.4
22.00S	1.443	7.399	2.187	36.9
30.00S	0.266	9.070	1.250	38.5
35.00S	-0.585	10.289	0.579	39.2
40.00S	-1.471	11.683	-0.184	39.7

Note: Drafts are measured at A.P. and F.P along ship's centerline

GZ SUMMARY (Evaluated per IMO (SOLAS '90) Rules for Passenger Ships)
Available Required

Static Heel Angle	0.00 deg	7.00 deg
Freeboard to Margin Line	1.388 ft	0.000 ft
Freeboard to Downflooding	2.222 ft	
Angle at Maximum GZ	16.00S deg	
Maximum GZ	1.946 ft	1.320 ft
Range of Positive GZ	31.60 deg	15.00 deg
Gmt (upright damaged)	9.514 ft	
Righting Area (0.00-3.00)	29.739 ft-deg	2.820 ft-deg

**APPENDIX B
HYDROSTATICS AND
DAMAGE STABILITY
OUTPUT**

200' EXCURSION BOAT

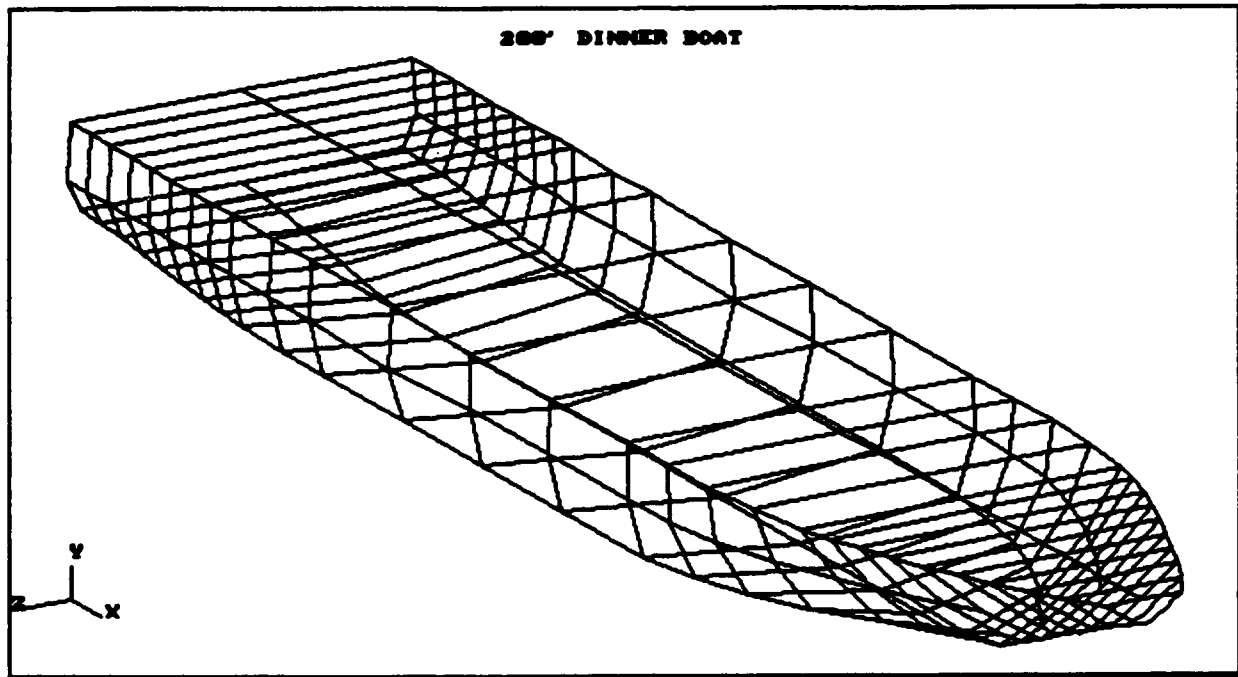

DAMAGE STABILITY SUMMARY

N.	FILE NAME	DAMAGED COMP. LISTING	---Intact Condition---			-----Equilibrium Condition After Damage-----					
			MIN.DRAFT (ft)	VCG (ft)	GMT (ft)	HEEL (deg)	MAX.GZ (ft)	RANGE (deg)	AREA (ft-deg)	DAM.GMT (ft)	SURVIVAL
1	DPRT001A	1,2	8.395	20.890	7.247	0.0	2.065	40.0	58.7	7.071	Yes
2	DPRT002A	2,3	8.395	20.890	7.247	0.0	1.995	40.0	55.5	5.095	Yes
3	DPRT003A	3,4	8.395	20.890	7.247	0.0	1.882	40.0	51.6	4.349	Yes
4	DPRT004A	4,5	8.395	20.890	7.247	0.0	1.804	40.0	48.3	3.798	Yes
5	DPRT005A	6	8.395	20.890	7.247	0.0	1.892	40.0	53.4	5.509	Yes
6	DPRT006A	7	8.395	20.890	7.247	0.8S	2.183	39.2	62.1	----	Yes
7	DPRT007A	13	8.395	20.890	7.247	0.0	2.062	40.0	56.9	4.526	Yes
8	DPRT008A	14	8.395	20.890	7.247	0.0	1.935	40.0	53.5	5.476	Yes
9	DPRT009A	7,12	8.395	20.890	7.247	2.7S	1.731	37.3	46.9	----	Yes
10	DPRT010A	7,10	8.395	20.890	7.247	2.6S	1.805	37.4	48.9	----	Yes
11	DPRT011A	7,10,12	8.395	20.890	7.247	5.0S	1.334	35.0	33.4	----	Yes
12	DPRT012A	7,9	8.395	20.890	7.247	0.0P	2.436	40.0	69.2	6.950	Yes
13	DPRT013A	7,9,10	8.395	20.890	7.247	1.6S	2.073	38.4	56.2	----	Yes
14	DPRT014A	7,9,12	8.395	20.890	7.247	1.6S	2.000	38.4	54.3	----	Yes
15	DPRT015A	7,9,10,12	8.395	20.890	7.247	3.6S	1.606	36.4	40.6	----	Yes

DAMAGE STABILITY SUMMARY

N.	FILE NAME	DAMAGED COMP. LISTING	---Intact Condition---			-----Equilibrium Condition After Damage-----					
			MM.DRAFT (ft)	VCG (ft)	GMT (ft)	HEEL (deg)	MAX.GZ (ft)	RANGE (deg)	AREA (ft-deg)	DAM.GMT (ft)	SURVIVAL
1	RTRN001B	1,2	8.230	21.140	7.602	0.0	2.028	40.0	57.1	7.321	Yes
2	RTRN002B	2,3	8.230	21.140	7.602	0.0	1.929	40.0	53.7	5.053	Yes
3	RTRN003B	3,4	8.230	21.140	7.602	0.0	1.799	40.0	49.4	4.100	Yes
4	RTRN004B	4,5	8.230	21.140	7.602	0.0	1.699	40.0	46.0	3.947	Yes
5	RTRN005B	6	8.230	21.140	7.602	0.0	1.841	40.0	51.8	5.765	Yes
6	RTRN006B	7	8.230	21.140	7.602	0.8s	2.134	39.2	60.5	----	Yes
7	RTRN007B	13	8.230	21.140	7.602	0.0	1.991	40.0	54.6	4.710	Yes
8	RTRN008B	14	8.230	21.140	7.602	0.0	1.897	40.0	52.0	5.761	Yes
9	RTRN009B	7,12	8.230	21.140	7.602	0.7P	2.077	39.3	57.2	----	Yes
10	RTRN010B	7,10	8.230	21.140	7.602	0.2P	2.118	39.8	58.9	----	Yes
11	RTRN011B	7,10,12	8.230	21.140	7.602	2.0P	1.881	38.0	50.3	----	Yes
12	RTRN012B	7,9	8.230	21.140	7.602	0.8s	2.182	39.2	59.6	----	Yes
13	RTRN013B	7,9,10	8.230	21.140	7.602	0.2P	2.168	39.8	60.3	----	Yes
14	RTRN014B	7,9,12	8.230	21.140	7.602	0.7P	2.126	39.3	58.5	----	Yes
15	RTRN015B	7,9,10,12	8.230	21.140	7.602	2.0P	1.925	38.0	51.5	----	Yes

HYDROSTATIC TABLES

LOADED DRAFT (ft)		2.000	4.000	6.000	8.000	10.000
DISP. MLD.	(LTons-SW)	18	169	422	710	1,025
DISP. TOTAL	(LTons-SW)	19	171	422	710	1,025
DISP. TOTAL	(LTons-FW)	19	167	411	693	1,000
CB	(ft-FP)	76.021A	78.819A	80.704A	82.410A	84.016A
CB (forebody)	(ft-FP)	52.466A	52.228A	51.405A	50.192A	49.289A
CB (aftbody)	(ft-FP)	103.388A	106.418A	109.019A	111.965A	114.496A
ICB	(ft-CL)	0.000	0.000	0.000	0.000	0.000
CB	(ft)	1.634	3.002	4.214	5.356	6.480
IMt	(ft)	78.884	67.066	35.418	24.480	18.106
OMt	(ft)	80.518	70.067	39.632	29.837	24.587
IML	(ft)	3063.833	783.031	477.860	383.736	283.615
OML	(ft)	3065.467	786.033	482.074	389.093	290.095
TRI	(LTons)	4.7	9.8	11.6	12.9	13.4
	(ft-LTons)	29	69	105	142	151
	(LTons)	-0.0	0.1	0.3	0.7	0.6
LCF	(ft-FP)	78.984A	81.297A	83.920A	88.157A	87.080A
M.P. AREA	(ft2)	1,961	4,098	4,852	5,431	5,610
WETTED SUR.	(ft2)	1,998	4,181	5,308	6,349	7,088
MAX. BEAM	(ft)	13.119	37.085	37.699	38.364	39.029
LENGTH W.L.	(ft)	119.623	134.388	145.405	159.294	162.065
CB		0.0501	0.2306	0.3845	0.4852	0.5604
CB (forebody)		0.0539	0.2354	0.3810	0.4666	0.5258
CB (aftbody)		0.0464	0.2258	0.3881	0.5038	0.5951
CM		0.0897	0.3632	0.5536	0.6523	0.7143
CP		0.5592	0.6349	0.6947	0.7438	0.7845
CMp		0.3064	0.6403	0.7581	0.8486	0.8766
Cit		0.0593	0.4640	0.6129	0.7127	0.7611

Assumes: Sea Water at 35.0063 ft3/LT
Fresh Water at 35.8814 ft3/LT
Ship floating at even keel (no heel or trim)

DPR001A: FPK/THRUSTER
 200' DINNER BOAT

Damaged Compartments:

FOREPEAK BOWTHRUST

	DISPLACEMENT LTons	DRAFT AFT ft	DRAFT FWD ft	TRIM ft	HEEL deg.	UPRIGHT GMT ft
INTACT	782	9.080	7.710	1.370A	0.0	7.247
DAMAGED	830	8.487	9.114	0.627F	0.0	7.071

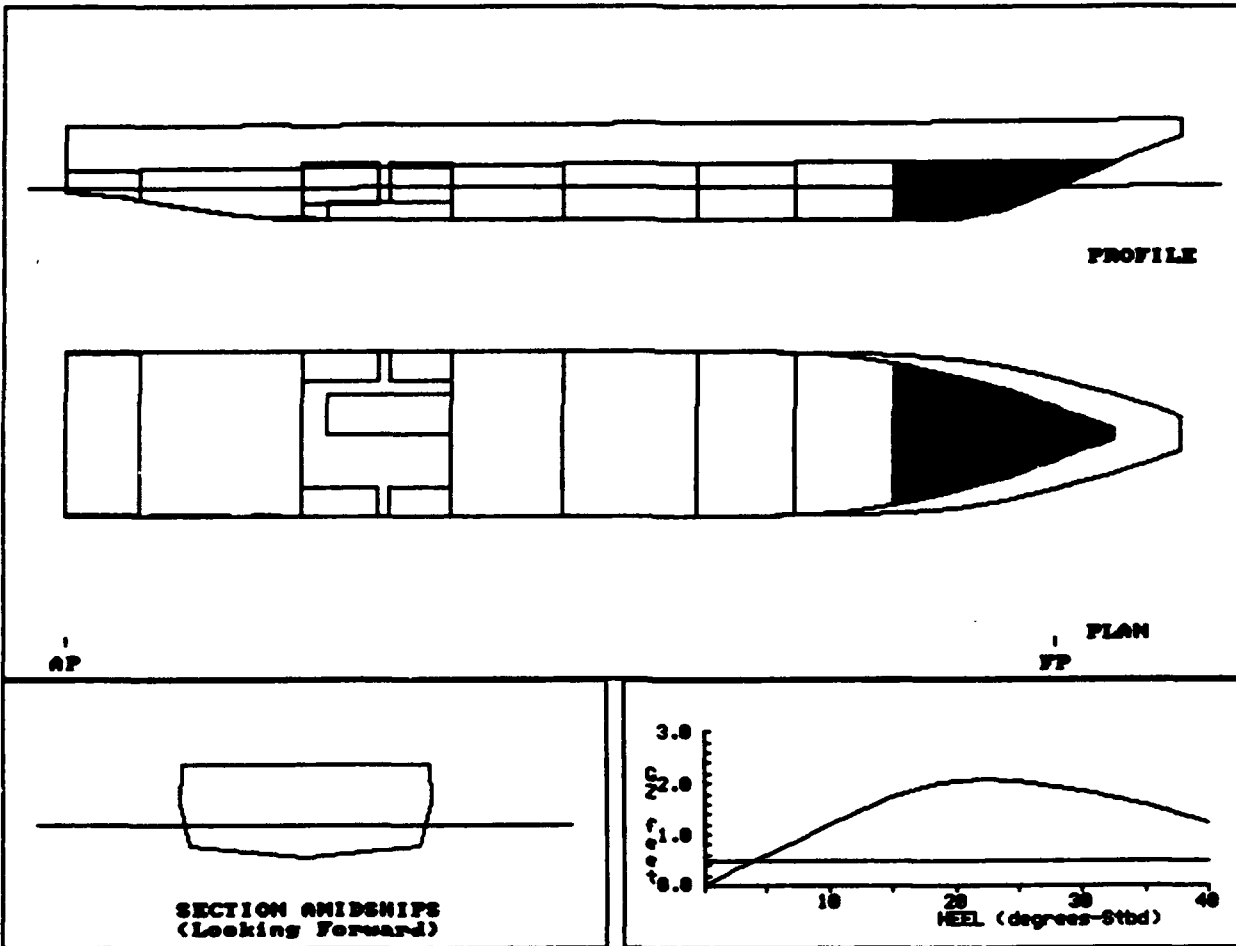

DPRT001A: FPK/THRUSTER
 200' DINNER BOAT

COMPARTMENT FLOODING SUMMARY

At 0.0o Heel	PERM.	FLOODED WTR LTons	% FULL (Damaged)	% FULL (Intact)	SP.VOL. ft ³ /LT	OUTFLOW LTons
FOREPEAK	0.95	5	FREE	0.0	----	----
BOWTHRUST	0.85	42	FREE	0.0	----	----
Totals		48				

INTACT DATA

Draft at AP = 9.080 ft	KMT = 28.137 ft	LCG = 85.794A ft-FP
Draft at FP = 7.710 ft	VCG = 20.890 ft	LCB = 85.925A ft-FP
Displacement = 782 LTons	GMT = 7.247 ft	TCG = 0.000 ft-CL

DRAFT/GZ DATA

HEEL degrees	RIGHTING ARM ft	DRAFT AFT ft	DRAFT FWD ft	FLOODED WATER LTons
0.0	0.000	8.487	9.114	48
5.0S	0.602	8.438	9.125	48
7.0S	0.832	8.386	9.140	48
10.0S	1.175	8.275	9.168	49
15.0S	1.739	7.960	9.261	51
20.0S	2.036	7.447	9.272	53
22.0S	2.065	7.210	9.208	53
27.0S	1.986	6.438	8.971	53
30.0S	1.865	5.900	8.713	52
35.0S	1.582	4.859	8.102	49
40.0S	1.239	3.574	7.229	45

Note: Drafts are measured at A.P. and F.P along ship's centerline

GZ SUMMARY (Evaluated per IMO (SOLAS'90) Rules for Passenger Ships)

	Available	Required
Static Heel Angle	0.0 deg	7.0 deg
Angle at Maximum GZ	23.0S deg	
Maximum GZ	2.065 ft	0.480 ft
Range of Positive GZ	40.0 deg	15.0 deg
Gmt (upright damaged)	7.071 ft	
Righting Area (0.0-22.0)	26.97 ft-deg	2.82 ft-deg

DPRT002A: THRUSTER/STOR1
 200' DINNER BOAT

aged Compartments:
 BOWTHRUST STORAGE1

	DISPLACEMENT LTons	DRAFT AFT ft	DRAFT FWD ft	TRIM ft	HEEL deg.	UPRIGHT Gmt ft
INTACT	782	9.080	7.710	1.370A	0.0	7.247
DAMAGED	972	7.305	12.408	5.103F	0.0	5.095

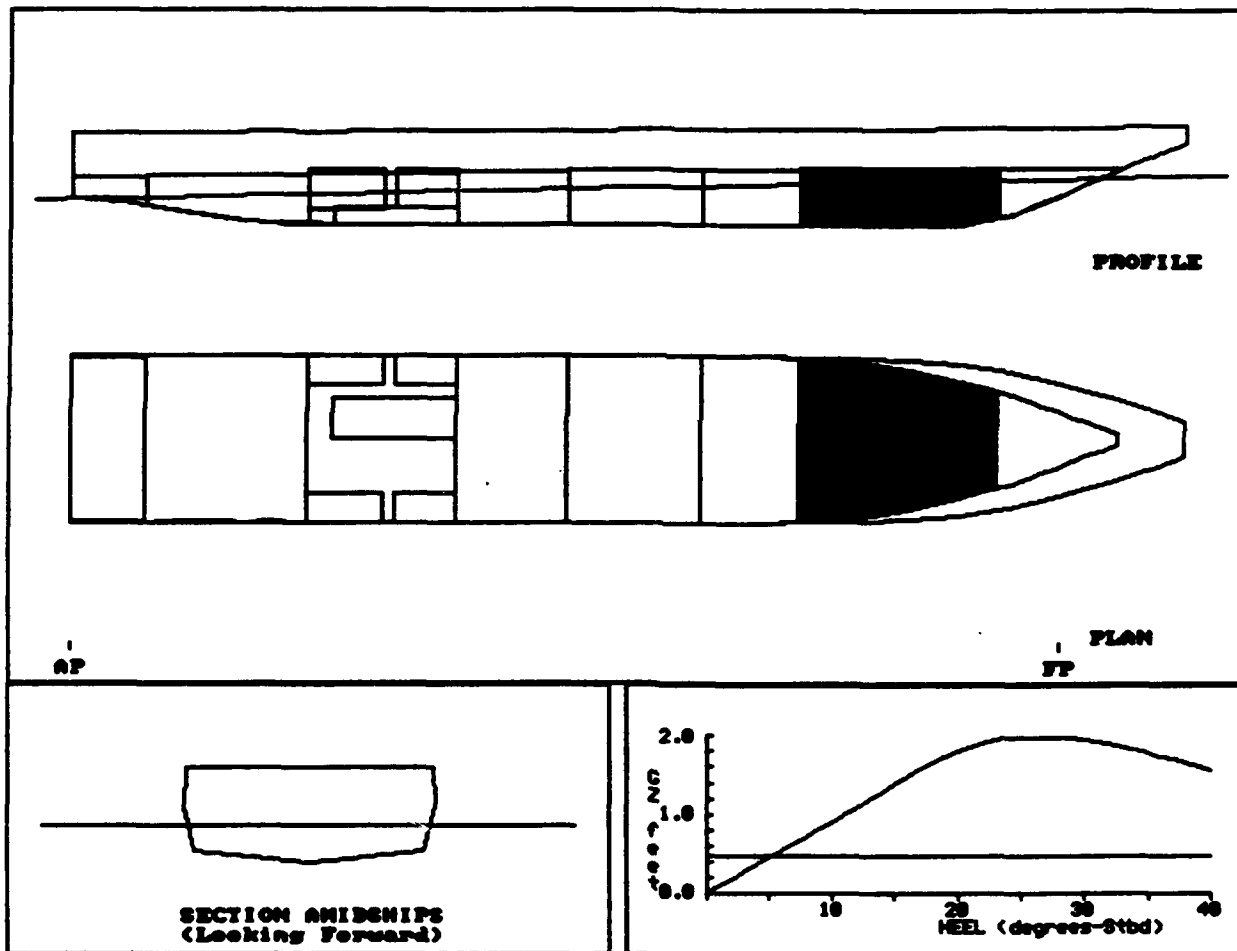

DPRT002A: THRUSTER/STOR1
 200' DINNER BOAT

COMPARTMENT FLOODING SUMMARY

At 0.0o Heel	PERM.	FLOODED WTR LTons	% FULL (Damaged)	% FULL (Intact)	SP.VOL. ft3/LT	OUTFLOW LTons
BOWTHRUST	0.85	68	FREE	0.0	----	----
STORAGE1	0.95	121	FREE	0.0	----	----
Totals		190				

INTACT DATA

Draft at AP = 9.080 ft	Kmt = 28.137 ft	LCG = 85.794A ft-FP
Draft at FP = 7.710 ft	VCG = 20.890 ft	LCB = 85.925A ft-FP
Displacement = 782 LTons	Gmt = 7.247 ft	TCG = 0.000 ft-CL

DRAFT/GZ DATA

HEEL degrees	RIGHTING ARM ft	DRAFT AFT ft	DRAFT FWD ft	FLOODED WATER LTons
0.0	0.000	7.305	12.408	190
5.0S	0.451	7.217	12.445	191
7.0S	0.630	7.134	12.487	192
10.0S	0.896	6.977	12.560	194
15.0S	1.386	6.653	12.598	194
20.0S	1.810	6.195	12.507	188
22.0S	1.913	5.966	12.421	184
27.0S	1.994	5.258	12.083	174
30.0S	1.954	4.756	11.775	167
35.0S	1.788	3.739	11.098	155
40.0S	1.555	2.493	10.168	144

Note: Drafts are measured at A.P. and F.P along ship's centerline

GZ SUMMARY (Evaluated per IMO (SOLAS'90) Rules for Passenger Ships)

	Available	Required
Static Heel Angle	0.0 deg	7.0 deg
Angle at Maximum GZ	27.0S deg	
Maximum GZ	1.995 ft	0.480 ft
Range of Positive GZ	40.0 deg	15.0 deg
Gmt (upright damaged)	5.095 ft	
Righting Area (0.0-22.0)	21.98 ft-deg	2.82 ft-deg

DPRT003A: STOR 1/PREP
 200' DINNER BOAT

aged Compartments:

STORAGE1 PREP RM

	DISPLACEMENT LTons	DRAFT AFT ft	DRAFT FWD ft	TRIM ft	HEEL deg.	UPRIGHT GMT ft
INTACT	782	9.080	7.710	1.370A	0.0	7.247
DAMAGED	1,061	7.593	13.252	5.659F	0.0	4.349

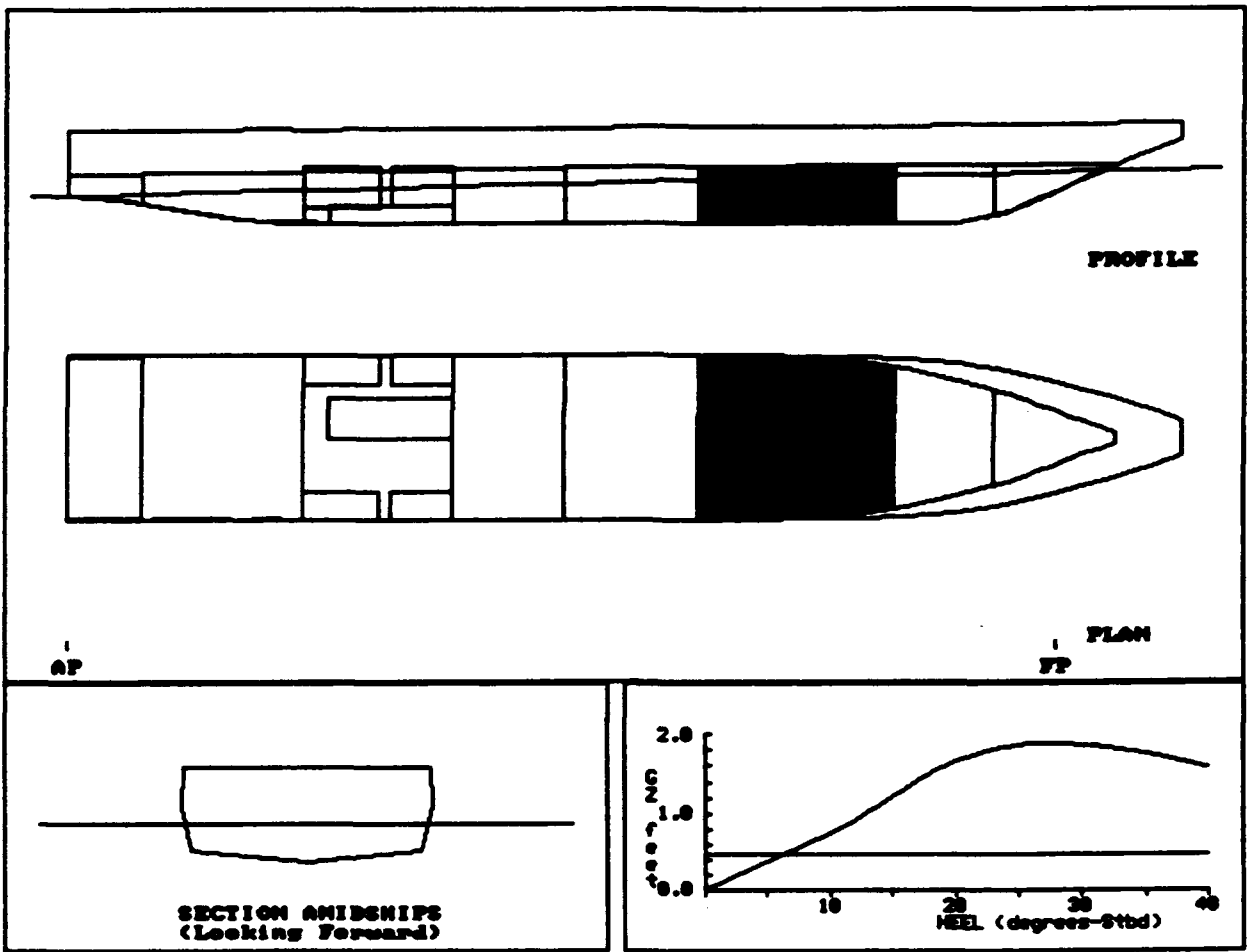

DPRT003A: STOR 1/PREP
 200' DINNER BOAT

COMPARTMENT FLOODING SUMMARY

At 0.0o Heel	PERM.	FLOODED WTR LTons	% FULL (Damaged)	% FULL (Intact)	SP.VOL. ft3/LT	OUTFLO LTons
STORAGE1	0.95	132	FREE	0.0	----	----
PREP RM	0.95	146	FREE	0.0	----	----
Totals		278				

INTACT DATA

Draft at AP = 9.080 ft	KMt = 28.137 ft	LCG = 85.794A ft-FP
Draft at FP = 7.710 ft	VCG = 20.890 ft	LCB = 85.925A ft-FP
Displacement = 782 LTons	Gmt = 7.247 ft	TCG = 0.000 ft-CL

DRAFT/GZ DATA

HEEL degrees	RIGHTING ARM ft	DRAFT AFT ft	DRAFT FWD ft	FLOODED WATER LTons
0.0	0.000	7.593	13.252	278
5.0S	0.371	7.511	13.282	279
7.0S	0.515	7.445	13.299	279
10.0S	0.739	7.320	13.317	280
15.0S	1.224	7.087	13.169	271
20.0S	1.659	6.706	12.945	257
22.0S	1.767	6.502	12.821	250
27.0S	1.881	5.836	12.426	233
30.0S	1.868	5.344	12.108	224
35.0S	1.758	4.332	11.442	209
40.0S	1.578	3.071	10.547	194

Note: Drafts are measured at A.P. and F.P along ship's centerline

GZ SUMMARY (Evaluated per IMO (SOLAS'90) Rules for Passenger Ships)

	Available	Required
Static Heel Angle	0.0 deg	7.0 deg
Angle at Maximum GZ	29.0S deg	
Maximum GZ	1.882 ft	0.480 ft
Range of Positive GZ	40.0 deg	15.0 deg
Gmt (upright damaged)	4.349 ft	
Righting Area (0.0-22.0)	19.27 ft-deg	2.82 ft-deg

DPRT004A: PREP/STOR 2
 200' DINNER BOAT

Seaged Compartments:
 PREP RM STORAGE2

	DISPLACEMENT LTons	DRAFT AFT ft	DRAFT FWD ft	TRIM ft	HEEL deg.	UPRIGHT GMT ft
INTACT	782	9.080	7.710	1.370A	0.0	7.247
DAMAGED	1,119	8.885	12.562	3.677F	0.0	3.798

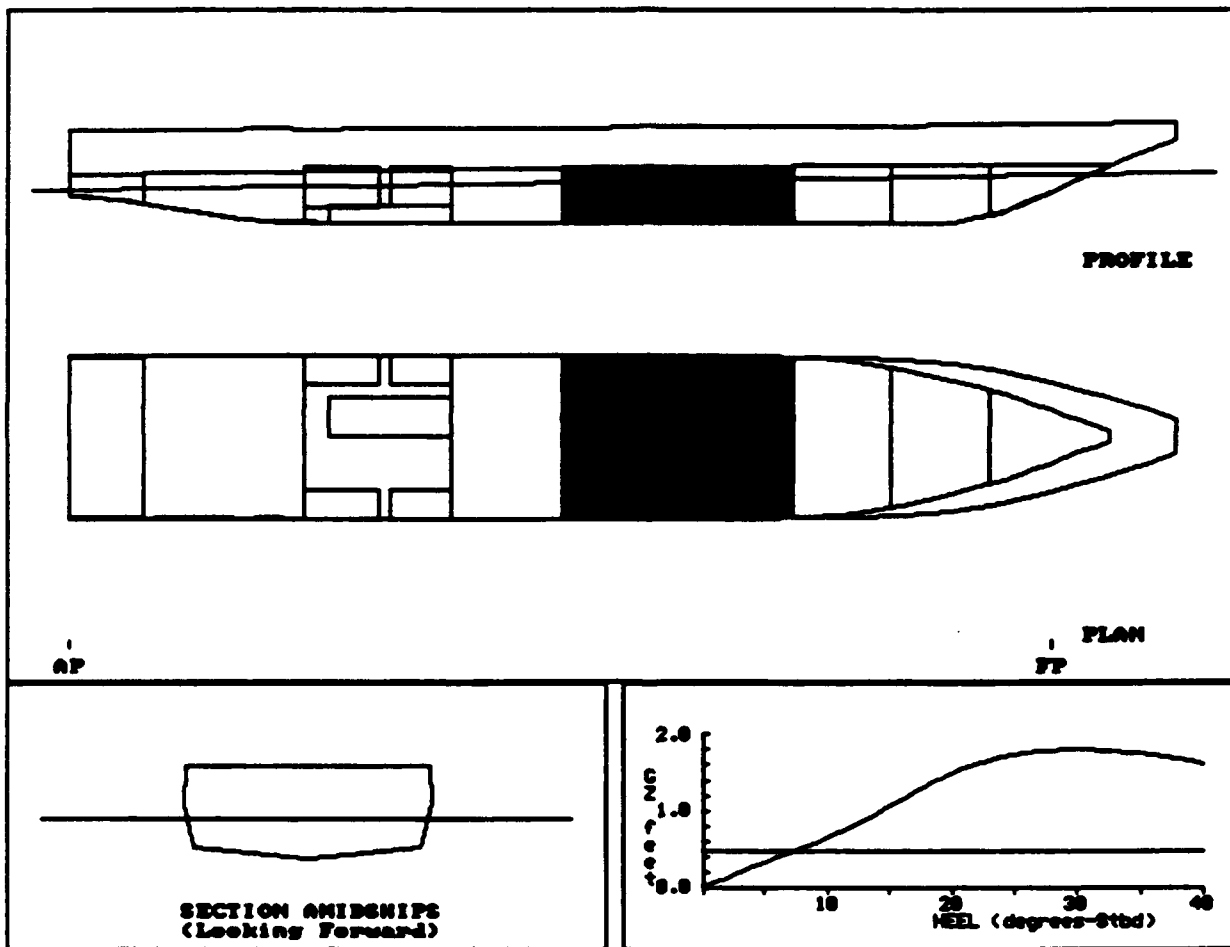

DPR004A: PREP/STOR 2
 200' DINNER BOAT

COMPARTMENT FLOODING SUMMARY

At 0.0o Heel	PERM.	FLOODED WTR LTons	% FULL (Damaged)	% FULL (Intact)	SP.VOL. ft3/LT	OUTFLOW LTons
PREP RM	0.95	145	FREE	0.0	----	----
STORAGE2	0.95	192	FREE	0.0	----	----
Totals		337				

INTACT DATA

Draft at AP = 9.080 ft	KMt = 28.137 ft	LCG = 85.794A ft-FP
Draft at FP = 7.710 ft	VCG = 20.890 ft	LCB = 85.925A ft-FP
Displacement = 782 LTons	GMT = 7.247 ft	TCG = 0.000 ft-CL

DRAFT/GZ DATA

HEEL degrees	RIGHTING ARM ft	DRAFT AFT ft	DRAFT FWD ft	FLOODED WATER LTons
0.0	0.000	8.885	12.562	337
5.0S	0.330	8.865	12.543	337
7.0S	0.456	8.835	12.530	337
10.0S	0.641	8.757	12.511	336
15.0S	1.055	8.548	12.378	327
20.0S	1.493	8.211	12.140	309
22.0S	1.617	8.023	12.008	300
27.0S	1.784	7.391	11.611	281
30.0S	1.804	6.907	11.305	270
35.0S	1.748	5.914	10.652	252
40.0S	1.623	4.651	9.789	236

Note: Drafts are measured at A.P. and F.P along ship's centerline

GZ SUMMARY (Evaluated per IMO (SOLAS'90) Rules for Passenger Ships)

	Available	Required
Static Heel Angle	0.0 deg	7.0 deg
Angle at Maximum GZ	31.0S deg	
Maximum GZ	1.804 ft	0.480 ft
Range of Positive GZ	40.0 deg	15.0 deg
Gmt (upright damaged)	3.798 ft	
Righting Area (0.0-22.0)	16.97 ft-deg	2.82 ft-deg

DPRT005A: AC MACHY
 200' DINNER BOAT

Imaged Compartments:
 AC MACHY

	DISPLACEMENT LTons	DRAFT AFT ft	DRAFT FWD ft	TRIM ft	HEEL deg.	UPRIGHT GMT ft
INTACT	782	9.080	7.710	1.370A	0.0	7.247
DAMAGED	892	9.801	8.395	1.406A	0.0	5.509

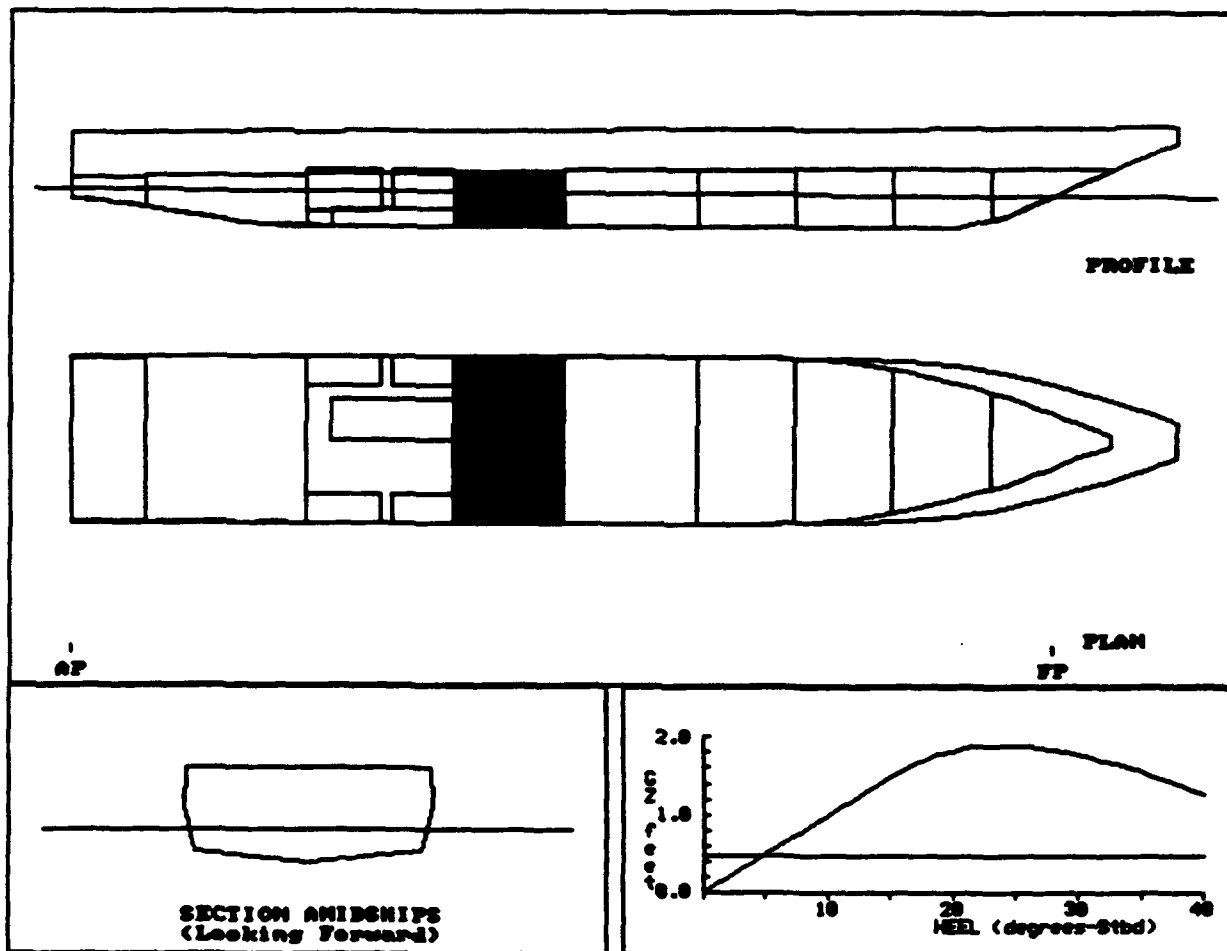

DPRT006A: LAVS
 200' DINNER BOAT

Damaged Compartments:
 LAVS

	DISPLACEMENT LTons	DRAFT AFT ft	DRAFT FWD ft	TRIM ft	HEEL deg.	UPRIGHT GMT ft
INTACT	782	9.080	7.710	1.370A	0.0	7.247
DAMAGED	908	10.617	7.601	3.017A	0.8S	6.719

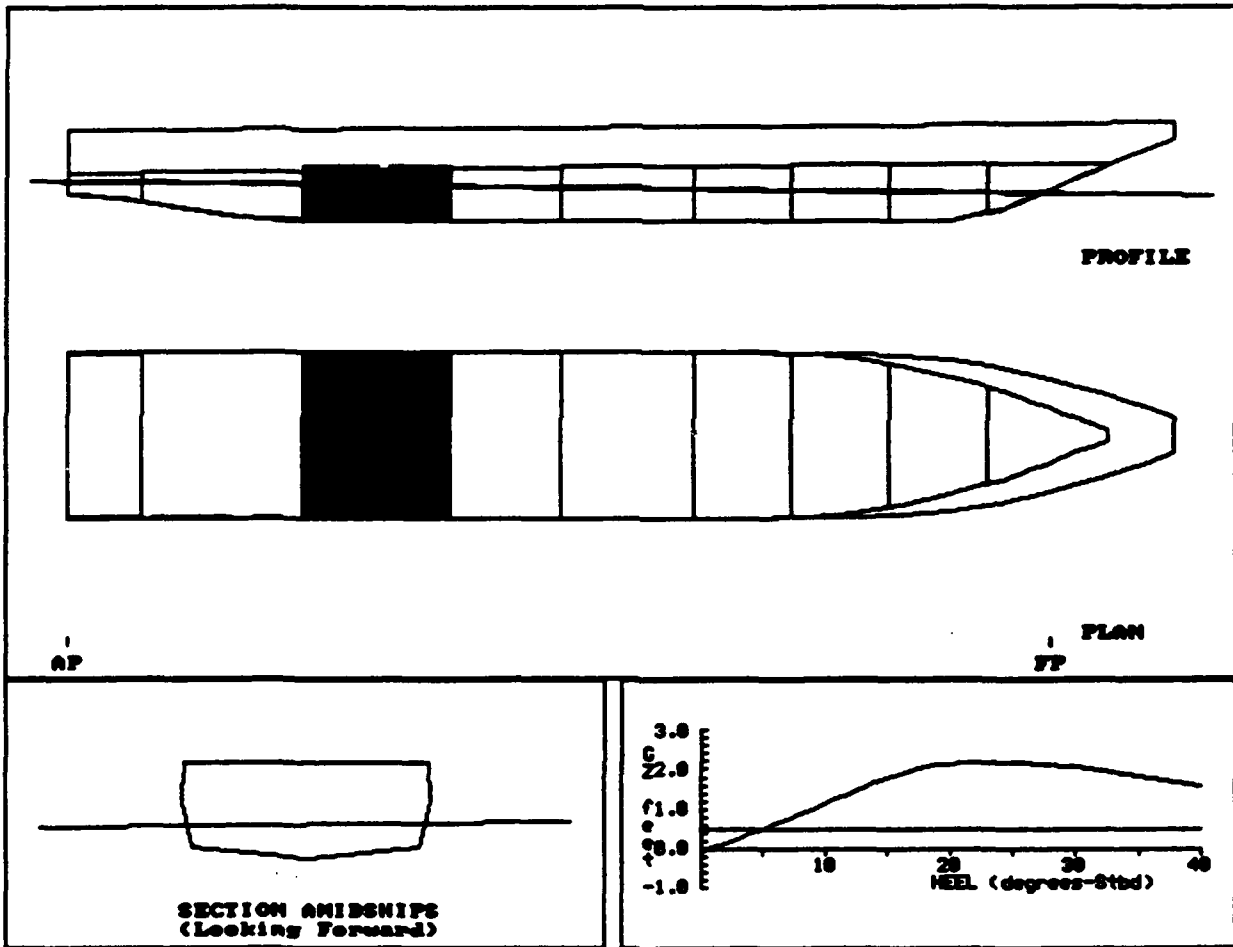

DPR006A: LAVS
 200' DINNER BOAT

COMPARTMENT FLOODING SUMMARY

At 0.8oS Heel	PERM.	FLOODED WTR LTons	% FULL (Damaged)	% FULL (Intact)	SP.VOL. ft ³ /LT	OUTFLOW LTons
LAVS	0.95	125	FREE	0.0	----	----
Totals		125				

INTACT DATA

Draft at AP = 9.080 ft	KMt = 28.137 ft	LCG = 85.794A ft-FP
Draft at FP = 7.710 ft	VCG = 20.890 ft	LCB = 85.925A ft-FP
Displacement = 782 LTons	GMT = 7.247 ft	TCG = 0.000 ft-CL

DRAFT/GZ DATA

HEEL degrees	RIGHTING ARM ft	DRAFT AFT ft	DRAFT FWD ft	FLOODED WATER LTons
0.0	-0.096	10.616	7.607	125
5.0S	0.497	10.617	7.569	125
7.0S	0.744	10.602	7.552	125
10.0S	1.127	10.571	7.511	125
15.0S	1.780	10.385	7.467	121
20.0S	2.147	10.001	7.295	111
22.0S	2.180	9.772	7.194	106
27.0S	2.135	9.094	6.826	98
30.0S	2.054	8.599	6.533	94
35.0S	1.833	7.581	5.927	88
40.0S	1.555	6.294	5.113	83

Note: Drafts are measured at A.P. and F.P along ship's centerline

GZ SUMMARY (Evaluated per IMO (SOLAS'90) Rules for Passenger Ships)
 Available Required

Static Heel Angle	0.8S deg	7.0 deg
Angle at Maximum GZ	24.0S deg	
Maximum GZ	2.183 ft	0.480 ft
Range of Positive GZ	39.2 deg	15.0 deg
Righting Area (0.8-22.0)	26.69 ft-deg	2.82 ft-deg

DPRT007A: ENGINE ROOM
 200' DINNER BOAT

Imaged Compartments:
 ENGINE ROOM

	DISPLACEMENT LTONS	DRAFT AFT ft	DRAFT FWD ft	TRIM ft	HEEL deg.	UPRIGHT GMT ft
INTACT	782	9.080	7.710	1.370A	0.0	7.247
DAMAGED	962	12.463	6.064	6.399A	0.0	4.526

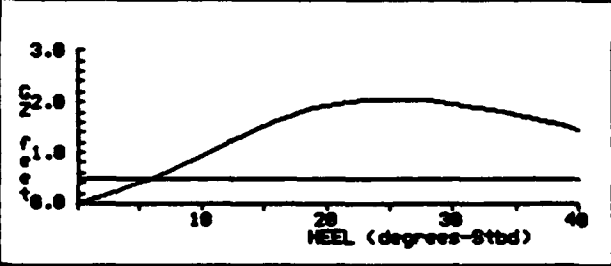
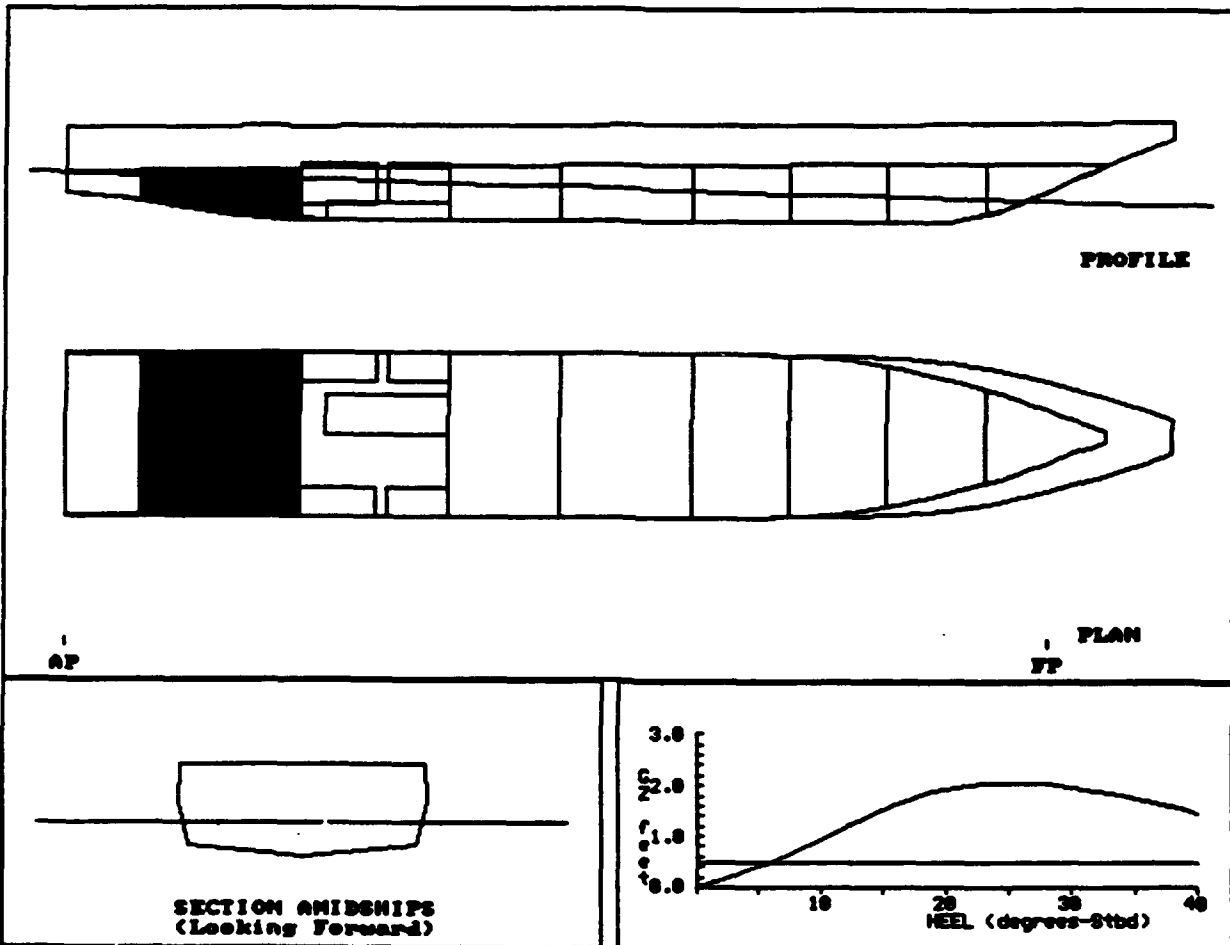

DPRT007A: ENGINE ROOM
 200' DINNER BOAT

COMPARTMENT FLOODING SUMMARY

At 0.0o Heel	PERM.	FLOODED WTR LTons	% FULL (Damaged)	% FULL (Intact)	SP.VOL. ft3/LT	OUTFLOW LTons
ENGINE ROOM	0.85	180	FREE	0.0	----	----
Totals		180				

INTACT DATA

Draft at AP = 9.080 ft Kmt = 28.137 ft LCG = 85.794A ft-FP
 Draft at FP = 7.710 ft VCG = 20.890 ft LCB = 85.925A ft-FP
 Displacement = 782 LTons GMT = 7.247 ft TCG = 0.000 ft-CL

DRAFT/GZ DATA

HEEL degrees	RIGHTING ARM ft	DRAFT AFT ft	DRAFT FWD ft	FLOODED WATER LTons
0.0	0.000	12.463	6.064	180
5.0S	0.404	12.459	6.037	180
7.0S	0.597	12.420	6.030	178
10.0S	0.931	12.282	6.057	173
15.0S	1.523	12.026	6.022	161
20.0S	1.941	11.655	5.862	148
22.0S	2.021	11.441	5.768	143
27.0S	2.047	10.784	5.408	131
30.0S	1.973	10.266	5.141	125
35.0S	1.754	9.207	4.568	115
40.0S	1.464	7.885	3.783	106

Note: Drafts are measured at A.P. and F.P along ship's centerline

GZ SUMMARY (Evaluated per IMO (SOLAS'90) Rules for Passenger Ships)
 Available Required

Static Heel Angle	0.0 deg	7.0 deg
Angle at Maximum GZ	26.0S deg	
Maximum GZ	2.062 ft	0.480 ft
Range of Positive GZ	40.0 deg	15.0 deg
Gmt (upright damaged)	4.526 ft	
Righting Area (0.0-22.0)	23.16 ft-deg	2.82 ft-deg

**DPRT008A: LAZARETTE
 200' DINNER BOAT**

**Managed Compartments:
 LAZARETTE**

	DISPLACEMENT LTons	DRAFT AFT ft	DRAFT FWD ft	TRIM ft	HEEL deg.	UPRIGHT GMT ft
INTACT	7.2	9.080	7.710	1.370A	0.0	7.247
DAMAGED	812	9.793	7.251	2.543A	0.0	5.476

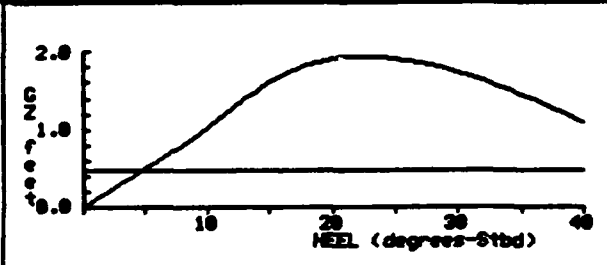
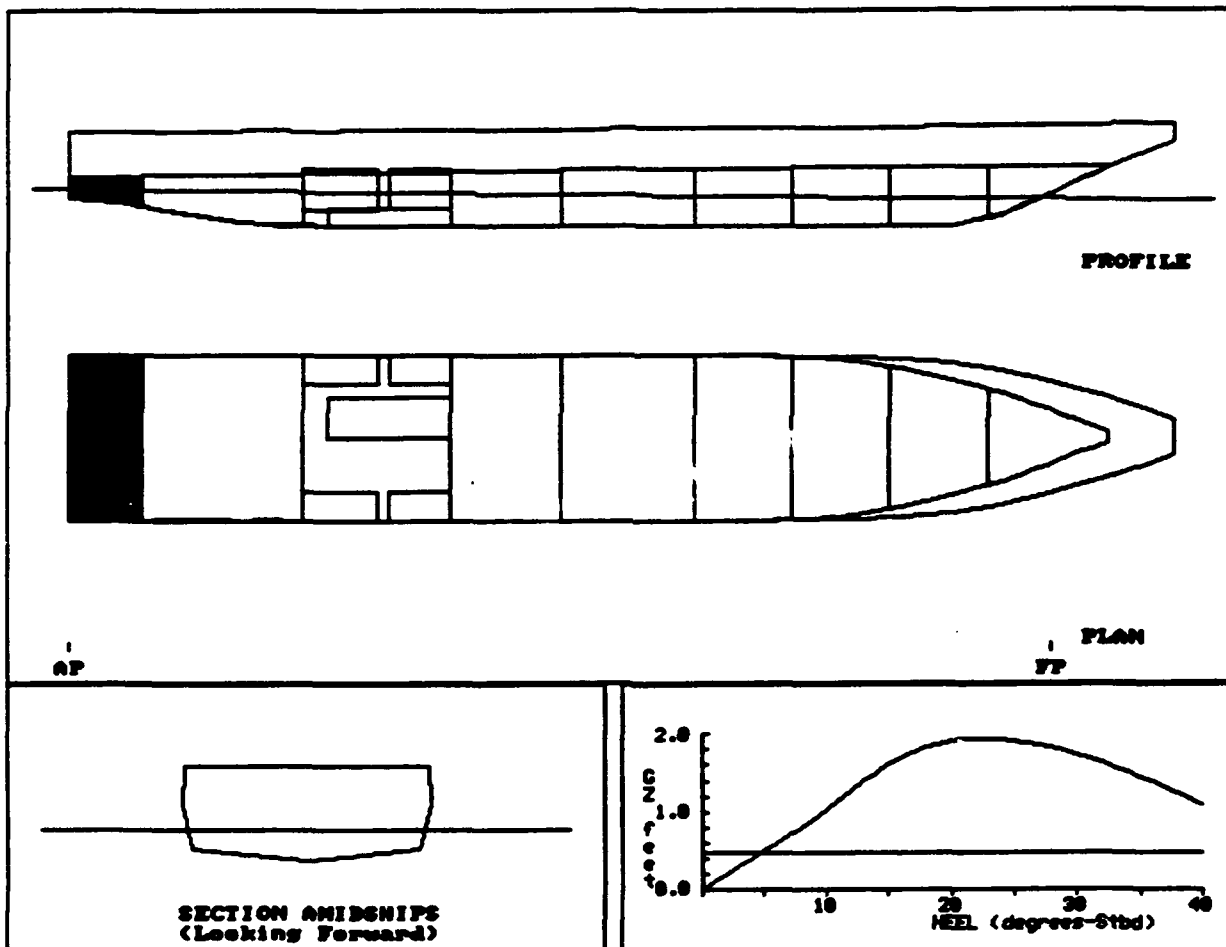

DPRT008A: LAZARETTE
 200' DINNER BOAT

COMPARTMENT FLOODING SUMMARY

At 0.0o Heel	PERM.	FLOODED WTR LTons	% FULL (Damaged)	% FULL (Intact)	SP.VOL. ft3/LT	OUTFLOW LTons
LAZARETTE	0.95	30	FREE	0.0	----	----
Totals		30				

INTACT DATA

Draft at AP = 9.080 ft	Kmt = 28.137 ft	LCG = 85.794A ft-FP
Draft at FP = 7.710 ft	VCG = 20.890 ft	LCB = 85.925A ft-FP
Displacement = 782 LTons	GMT = 7.247 ft	TCG = 0.000 ft-CL

DRAFT/GZ DATA

HEEL degrees	RIGHTING ARM ft	DRAFT AFT ft	DRAFT FWD ft	FLOODED WATER LTons
0.0	0.000	9.793	7.251	30
5.0S	0.484	9.794	7.221	30
7.0S	0.687	9.785	7.202	30
10.0S	1.012	9.761	7.160	31
15.0S	1.601	9.572	7.121	31
20.0S	1.903	9.204	6.941	30
22.0S	1.935	8.989	6.838	29
27.0S	1.858	8.333	6.453	28
30.0S	1.734	7.823	6.170	27
35.0S	1.444	6.781	5.574	25
40.0S	1.100	5.480	4.763	24

Note: Drafts are measured at A.P. and F.P along ship's centerline

GZ SUMMARY (Evaluated per IMO (SOLAS'90) Rules for Passenger Ships)
 Available Required

Static Heel Angle	0.0 deg	7.0 deg
Angle at Maximum GZ	24.0S deg	
Maximum GZ	1.935 ft	0.480 ft
Range of Positive GZ	40.0 deg	15.0 deg
Gmt (upright damaged)	5.476 ft	
Righting Area (0.0-22.0)	24.23 ft-deg	2.82 ft-deg

DEPT009A: LAVS/FUEL
 200' DINNER BOAT

Damaged Compartments:
 LAVS FUEL PORT

	DISPLACEMENT LTons	DRAFT AFT ft	DRAFT FWD ft	TRIM ft	HEEL deg.	UPRIGHT GMT ft
INTACT	782	9.080	7.710	1.370A	0.0	7.247
DAMAGED	896	10.464	7.611	2.853A	2.6S	6.140

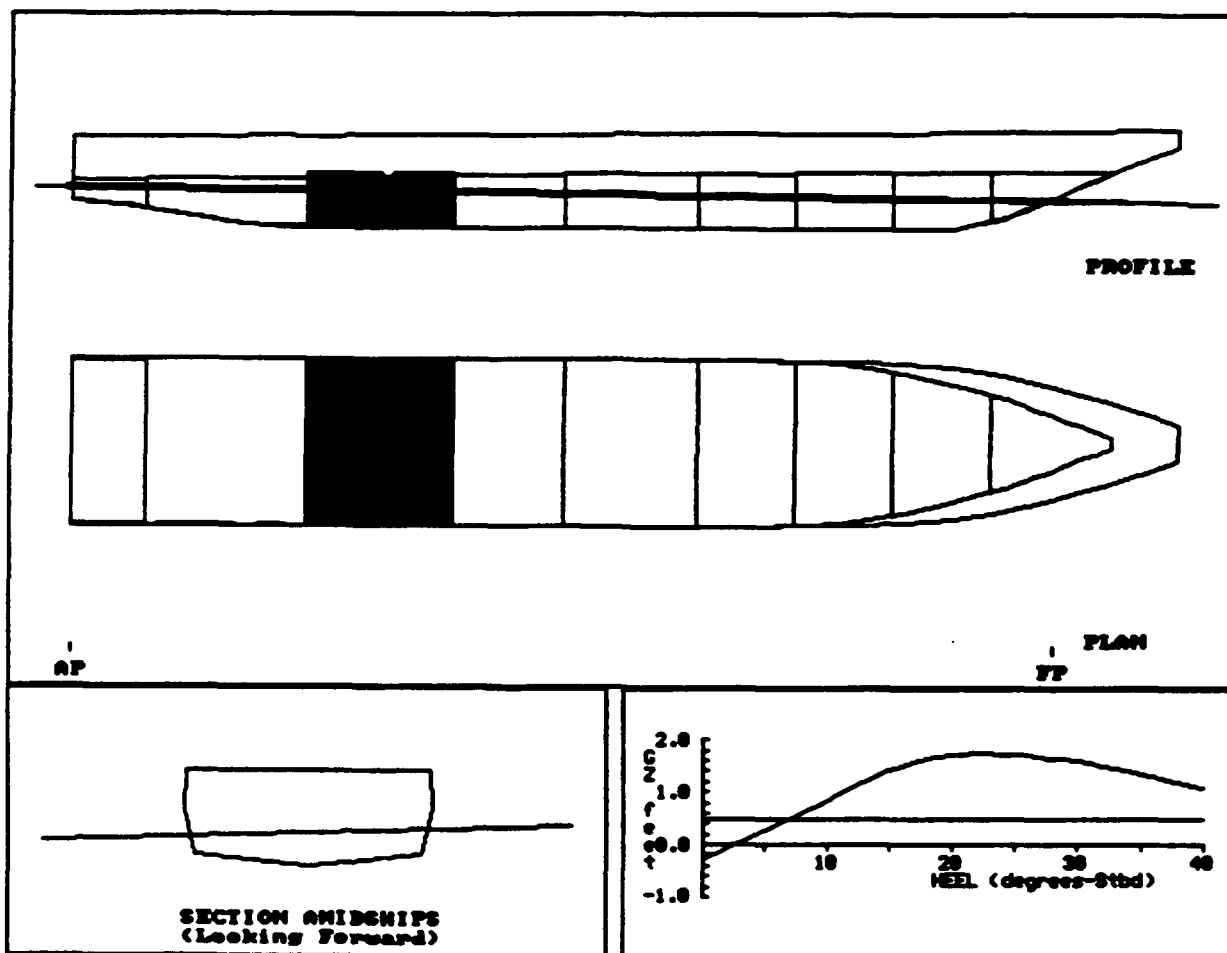

DEPT009A: LAVS/FUEL
 200' DINNER BOAT

COMPARTMENT FLOODING SUMMARY

At 2.6oS Heel	PERM.	FLOODED WTR LTons	% FULL (Damaged)	% FULL (Intact)	SP.VOL. ft ³ /LT	OUTFLOW LTons
LAVS	0.95	124	FREE	0.0	----	----
FUEL PORT	0.95	9	FREE	100.0	39.0000	19
Totals		132				19

INTACT DATA

Draft at AP = 9.080 ft	KMt = 28.137 ft	LCG = 85.794A ft-FP
Draft at FP = 7.710 ft	VCG = 20.890 ft	LCB = 85.925A ft-FP
Displacement = 782 LTons	GMT = 7.247 ft	TCG = 0.000 ft-CL

DRAFT/GZ DATA

HEEL degrees	RIGHTING ARM ft	DRAFT AFT ft	DRAFT FWD ft	FLOODED WATER LTons
0.0	-0.281	10.481	7.631	134
5.0S	0.261	10.439	7.597	130
7.0S	0.488	10.403	7.587	129
10.0S	0.835	10.339	7.553	126
15.0S	1.409	10.078	7.535	119
20.0S	1.711	9.625	7.380	107
22.0S	1.736	9.381	7.284	102
27.0S	1.679	8.675	6.924	95
30.0S	1.590	8.163	6.636	91
35.0S	1.356	7.112	6.038	86
40.0S	1.068	5.789	5.232	81

Note: Drafts are measured at A.P. and F.P along ship's centerline

GZ SUMMARY (Evaluated per IMO (SOLAS'90) Rules for Passenger Ships)

	Available	Required
Static Heel Angle	2.6S deg	7.0 deg
Angle at Maximum GZ	23.0S deg	
Maximum GZ	1.736 ft	0.480 ft
Range of Positive GZ	37.4 deg	15.0 deg
Righting Area (2.6-22.0)	20.09 ft-deg	2.82 ft-deg

DPRT010A: LAVS/E20
 200' DINNER BOAT

Damaged Compartments:
 LAVS FRESH H2O P

	DISPLACEMENT LTons	DRAFT AFT ft	DRAFT FWD ft	TRIM ft	HEEL deg.	UPRIGHT GMT ft
INTACT	782	9.080	7.710	1.370A	0.0	7.247
DAMAGED	895	10.495	7.566	2.928A	2.7S	6.241

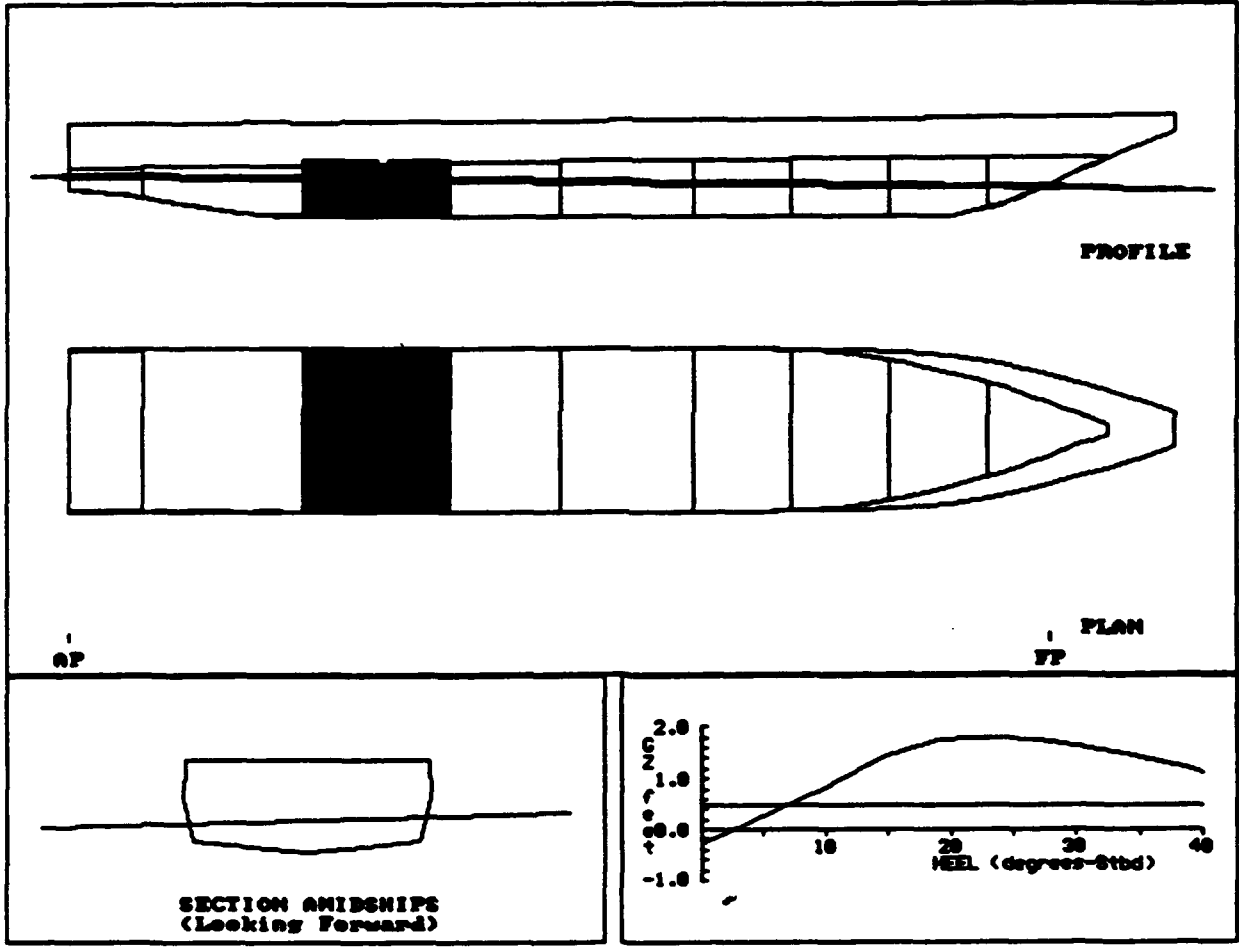

DPRT010A: LAVS/H2O
 200' DINNER BOAT

COMPARTMENT FLOODING SUMMARY

At 2.7oS Heel	PERM.	FLOODED WTR LTons	% FULL (Damaged)	% FULL (Intact)	SP.VOL. ft3/LT	OUTFLOW LTons
LAVS	0.95	124	FREE	0.0	----	----
FRESH H2O P	0.95	6	FREE	100.0	35.0063	17
Totals		130				17

INTACT DATA

Draft at AP = 9.080 ft KMT = 28.137 ft LCG = 85.794A ft-FP
 Draft at FP = 7.710 ft VCG = 20.890 ft LCB = 85.925A ft-FP
 Displacement = 782 LTons GMT = 7.247 ft TCG = 0.000 ft-CL

DRAFT/GZ DATA

HEEL degrees	RIGHTING ARM ft	DRAFT AFT ft	DRAFT FWD ft	FLOODED WATER LTons
0.0	-0.297	10.503	7.592	131
5.0S	0.254	10.478	7.547	128
7.0S	0.485	10.449	7.532	127
10.0S	0.840	10.397	7.490	125
15.0S	1.437	10.166	7.454	118
20.0S	1.769	9.745	7.286	108
22.0S	1.795	9.505	7.186	103
27.0S	1.739	8.809	6.819	95
30.0S	1.652	8.302	6.527	92
35.0S	1.420	7.261	5.922	86
40.0S	1.134	5.949	5.110	81

Note: Drafts are measured at A.P. and F.P along ship's centerline

GZ SUMMARY (Evaluated per IMO (SOLAS'90) Rules for Passenger Ships)
 Available Required

Static Heel Angle	2.7S deg	7.0 deg
Angle at Maximum GZ	23.0S deg	
Maximum GZ	1.795 ft	0.480 ft
Range of Positive GZ	37.3 deg	15.0 deg
Righting Area (2.7-22.0)	20.48 ft-deg	2.82 ft-deg

DPR011A: LAVS/FUEL/H2O
 200' DINNER BOAT

Managed Compartments:

LAVS FRESH H2O P FUEL PORT

	DISPLACEMENT LTons	DRAFT AFT ft	DRAFT FWD ft	TRIM ft	HEEL deg.	UPRIGHT GMT ft
INTACT	782	9.080	7.710	1.370A	0.0	7.247
DAMAGED	880	10.294	7.575	2.719A	5.0S	5.614

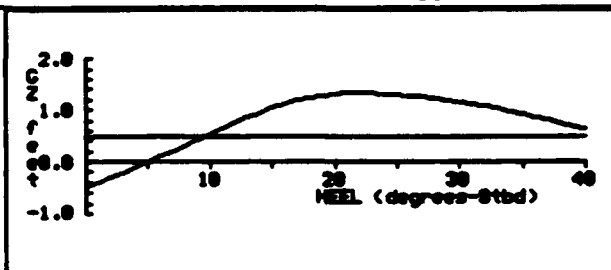
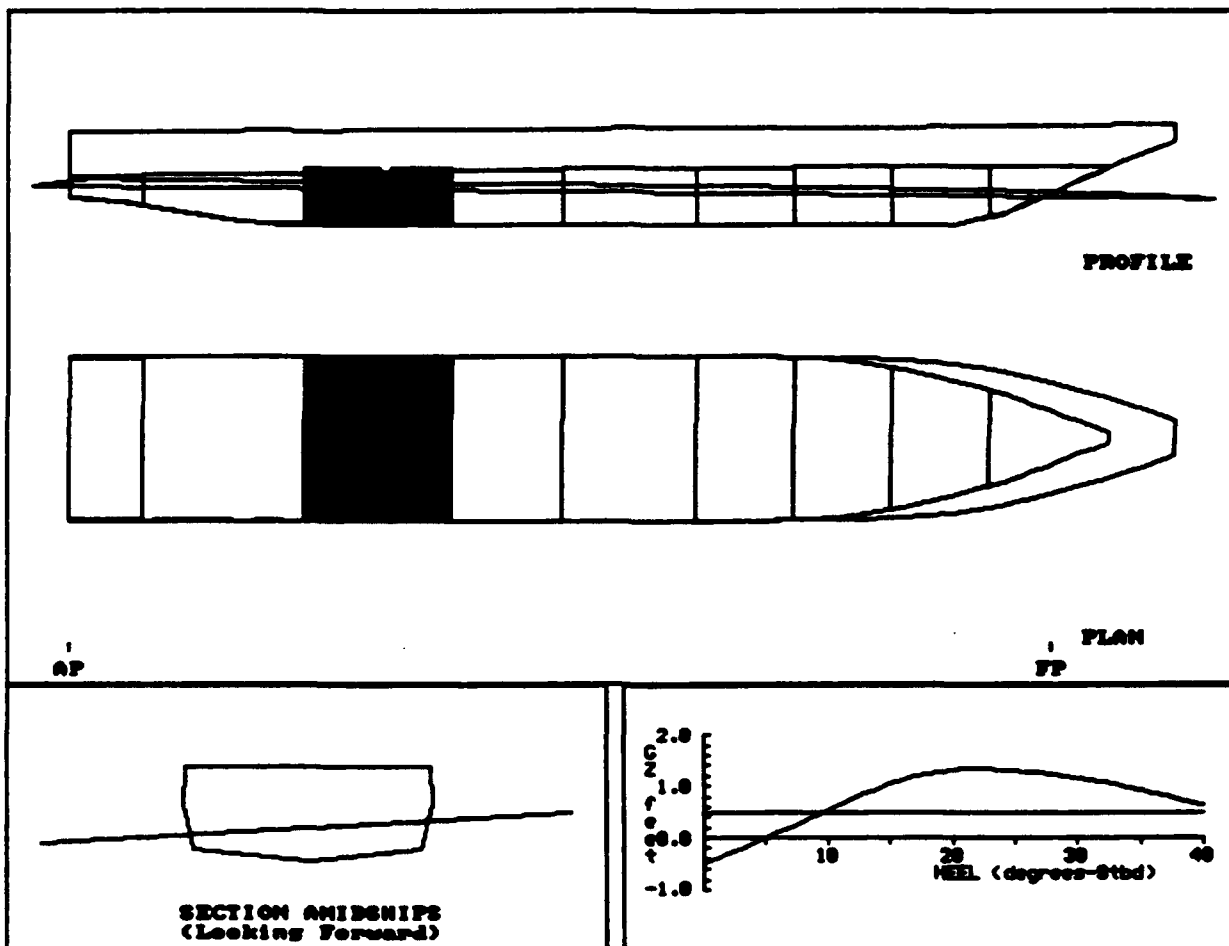

DEPT011A: LAVS/FUEL/H2O
 200' DINNER BOAT

COMPARTMENT FLOODING SUMMARY

At 5.0oS Heel	PERM.	FLOODED WTR LTons	% FULL (Damaged)	% FULL (Intact)	SP.VOL. ft ³ /LT	OUTFLOW LTons
LAVS	0.95	121	FREE	0.0	----	----
FRESH H2O P	0.95	5	FREE	100.0	35.0063	17
FUEL PORT	0.95	7	FREE	100.0	39.0000	19
Totals		133				35

INTACT DATA

Draft at AP = 9.080 ft	Kmt = 28.137 ft	LCG = 85.794A ft-FP
Draft at FP = 7.710 ft	VCG = 20.890 ft	LCB = 85.925A ft-FP
Displacement = 782 LTons	GMT = 7.247 ft	TCG = 0.000 ft-CL

DRAFT/GZ DATA

HEEL degrees	RIGHTING ARM ft	DRAFT AFT ft	DRAFT FWD ft	FLOODED WATER LTons
0.0	-0.499	10.363	7.617	140
5.0S	-0.002	10.294	7.575	133
7.0S	0.206	10.242	7.567	130
10.0S	0.522	10.155	7.534	126
15.0S	1.036	9.848	7.525	116
20.0S	1.311	9.364	7.373	104
22.0S	1.329	9.109	7.278	99
27.0S	1.262	8.384	6.920	92
30.0S	1.165	7.860	6.632	89
35.0S	0.921	6.784	6.036	84
40.0S	0.627	5.437	5.231	79

Note: Drafts are measured at A.P. and F.P along ship's centerline

GZ SUMMARY (Evaluated per IMO (SOLAS'90) Rules for Passenger Ships)

	Available	Required
Static Heel Angle	5.0S deg	7.0 deg
Angle at Maximum GZ	23.0S deg	
Maximum GZ	1.329 ft	0.480 ft
Range of Positive GZ	35.0 deg	15.0 deg
Righting Area (5.0-22.0)	13.88 ft-deg	2.82 ft-deg

DPR012A: LAVS/SEW TANK
 200' DINNER BOAT

Imaged Compartments:

LAVS SEW TANK

	DISPLACEMENT LTons	DRAFT AFT ft	DRAFT FWD ft	TRIM ft	HEEL deg.	UPRIGHT GMT ft
INTACT	782	9.080	7.710	1.370A	0.0	7.247
DAMAGED	926	10.827	7.605	3.222A	0.0	6.962

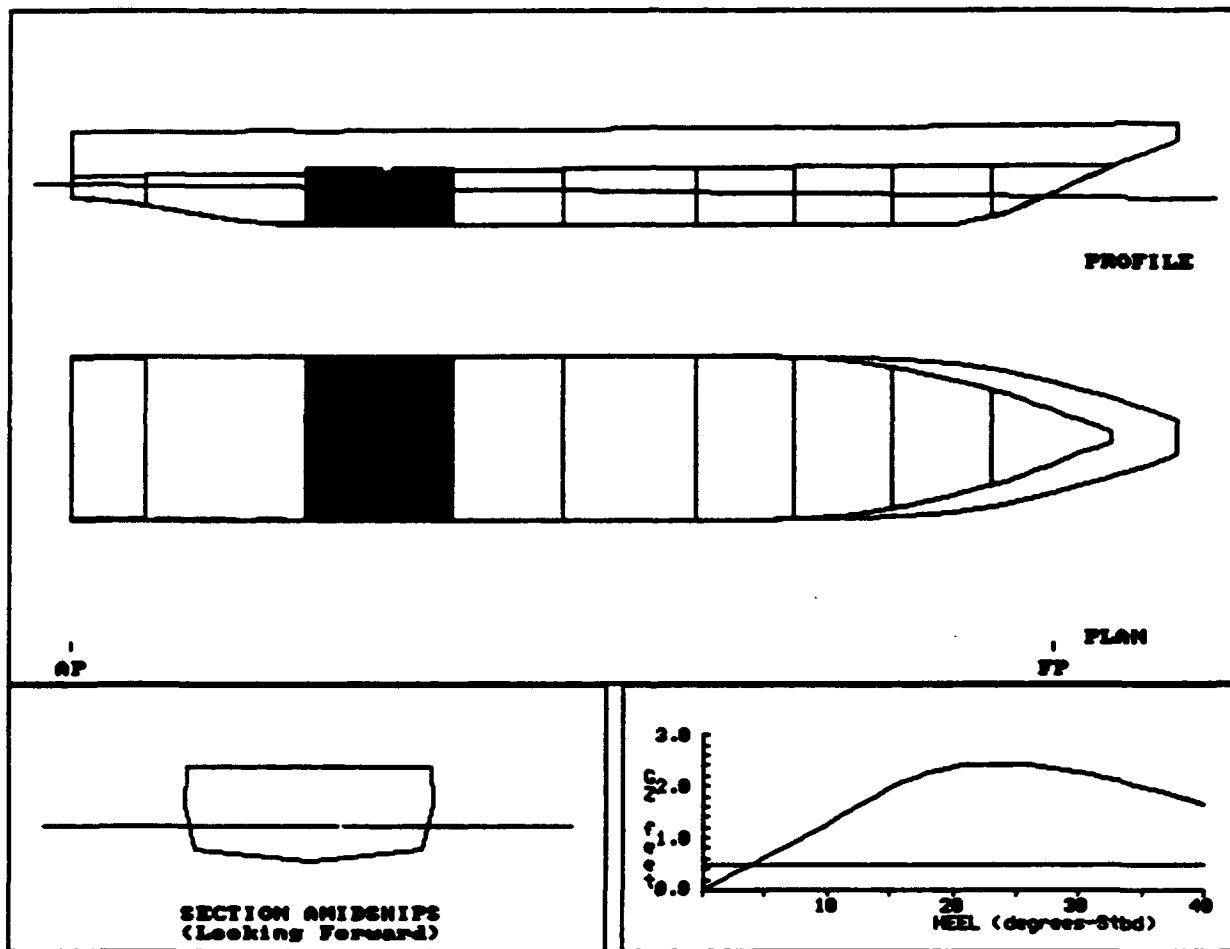

DFRT012A: LAVS/SEW TNK
 200' DINNER BOAT

COMPARTMENT FLOODING SUMMARY

At 0.0o Heel	PERM.	FLOODED WTR LTons	% FULL (Damaged)	% FULL (Intact)	SP.VOL. ft3/LT	OUTFLOW LTons
LAVS	0.95	128	FREE	0.0	----	----
SEW TANK	0.95	17	FREE	10.0	35.0063	2
Totals		145				2

INTACT DATA

Draft at AP = 9.080 ft	KMT = 28.137 ft	LCG = 85.794A ft-FP
Draft at FP = 7.710 ft	VCG = 20.890 ft	LCB = 85.925A ft-FP
Displacement = 782 LTons	GMT = 7.247 ft	TCG = 0.000 ft-CL

DRAFT/GZ DATA

HEEL degrees	RIGHTING ARM ft	DRAFT AFT ft	DRAFT FWD ft	FLOODED WATER LTons
0.0	0.000	10.827	7.605	145
5.0S	0.613	10.830	7.565	145
7.0S	0.867	10.815	7.548	145
10.0S	1.263	10.787	7.505	145
15.0S	1.952	10.614	7.453	141
20.0S	2.371	10.263	7.276	131
22.0S	2.420	10.046	7.173	127
27.0S	2.377	9.365	6.802	116
30.0S	2.266	8.840	6.511	110
35.0S	1.985	7.760	5.910	100
40.0S	1.643	6.402	5.102	90

Note: Drafts are measured at A.P. and F.P along ship's centerline

GZ SUMMARY (Evaluated per IMO (SOLAS'90) Rules for Passenger Ships)

	Available	Required
Static Heel Angle	0.0 deg	7.0 deg
Angle at Maximum GZ	24.0S deg	
Maximum GZ	2.428 ft	0.480 ft
Range of Positive GZ	40.0 deg	15.0 deg
Gmt (upright damaged)	6.962 ft	
Righting Area (0.0-22.0)	30.03 ft-deg	2.82 ft-deg

DPRT013A: LAVS/SEW/H2O
 200' DINNER BOAT

Damaged Compartments:

LAVS SEW TANK FRESH H2O P

	DISPLACEMENT LTons	DRAFT AFT ft	DRAFT FWD ft	TRIM ft	HEEL deg.	UPRIGHT Gmt ft
INTACT	782	9.080	7.710	1.370A	0.0	7.247
DAMAGED	914	10.713	7.573	3.140A	1.7S	6.462

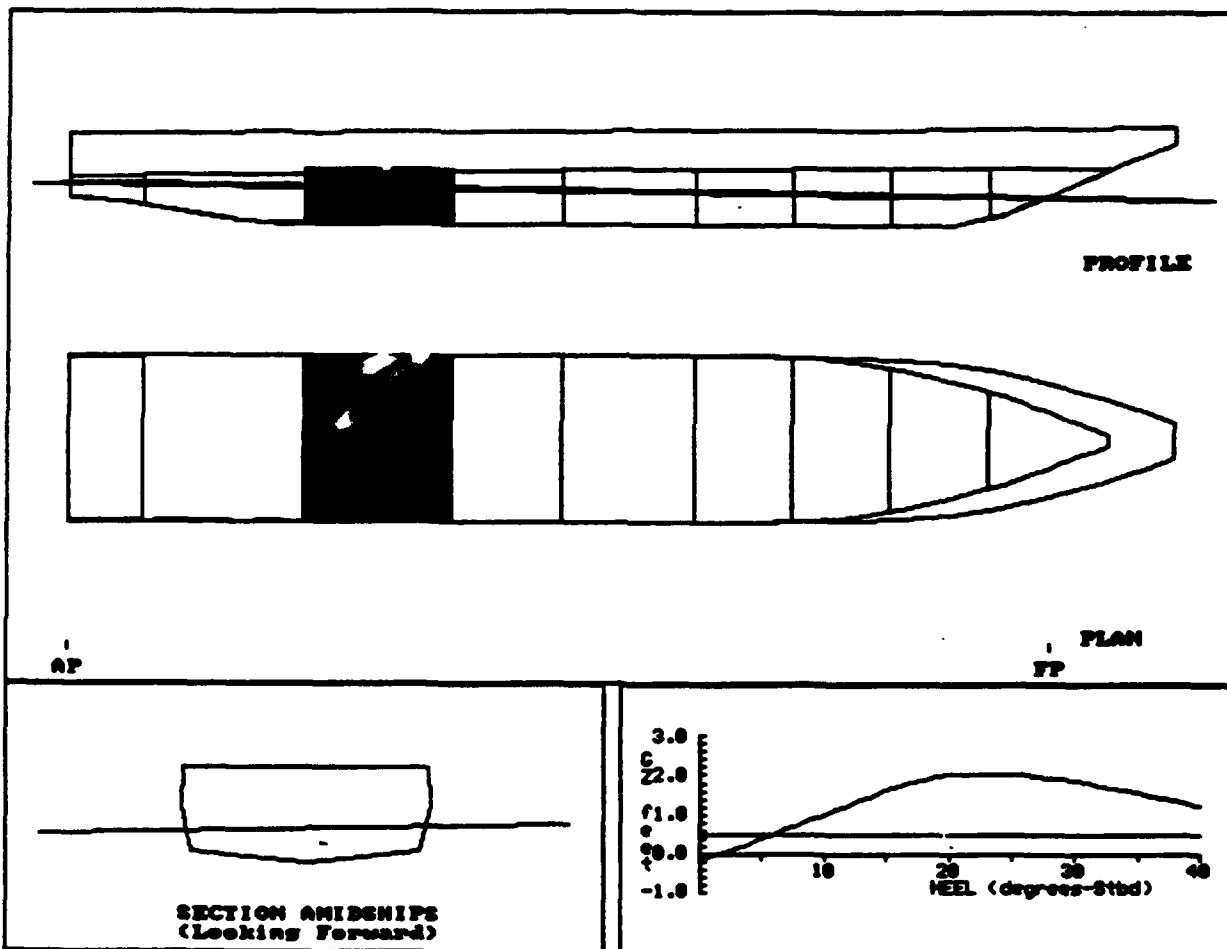

DPRT013A: LAVS/SEW/H2O
 200' DINNER BOAT

COMPARTMENT FLOODING SUMMARY

At 1.7oS Heel	PERM.	FLOODED WTR LTons	% FULL (Damaged)	% FULL (Intact)	SP.VOL. ft3/LT	OUTFLOW LTons
LAVS	0.95	127	FREE	0.0	----	----
SEW TANK	0.95	17	FREE	10.0	35.0063	2
FRESH H2O P	0.95	7	FREE	100.0	35.0063	17
Totals		151				18

INTACT DATA

Draft at AP = 9.080 ft Kmt = 28.137 ft LCG = 85.794A ft-FP
 Draft at FP = 7.710 ft VCG = 20.890 ft LCB = 85.925A ft-FP
 Displacement = 782 LTons GMT = 7.247 ft TCG = 0.000 ft-CL

DRAFT/GZ DATA

HEEL degrees	RIGHTING ARM ft	DRAFT AFT ft	DRAFT FWD ft	FLOODED WATER LTons
0.0	-0.194	10.717	7.591	152
5.0S	0.377	10.694	7.543	149
7.0S	0.614	10.665	7.527	147
10.0S	0.984	10.618	7.483	145
15.0S	1.617	10.400	7.439	138
20.0S	2.000	10.012	7.265	128
22.0S	2.041	9.783	7.163	124
27.0S	1.978	9.076	6.794	113
30.0S	1.855	8.537	6.505	107
35.0S	1.565	7.432	5.905	97
40.0S	1.214	6.047	5.100	88

Note: Drafts are measured at A.P. and F.P along ship's centerline

GZ SUMMARY (Evaluated per IMO (SOLAS'90) Rules for Passenger Ships)

	Available	Required
Static Heel Angle	1.7S deg	7.0 deg
Angle at Maximum GZ	24.0S deg	
Maximum GZ	2.045 ft	0.480 ft
Range of Positive GZ	38.3 deg	15.0 deg
Righting Area (1.7-22.0)	23.78 ft-deg	2.82 ft-deg

DPRT014A: LAVS/SEW/FUEL
200' DINNER BOAT

amaged Compartments:

LAVS

SEW TANK

FUEL PORT

	DISPLACEMENT LTONS	DRAFT AFT ft	DRAFT FWD ft	TRIM ft	HEEL deg.	UPRIGHT GNT ft
INTACT	782	9.080	7.710	1.370A	0.0	7.247
DAMAGED	915	10.688	7.615	3.073A	1.6S	6.362

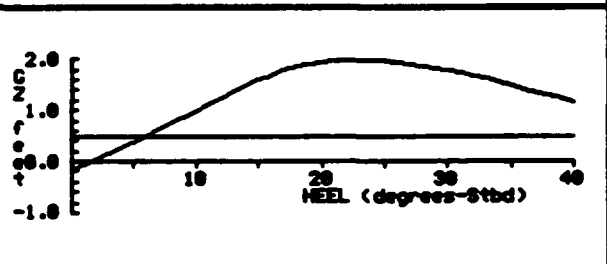
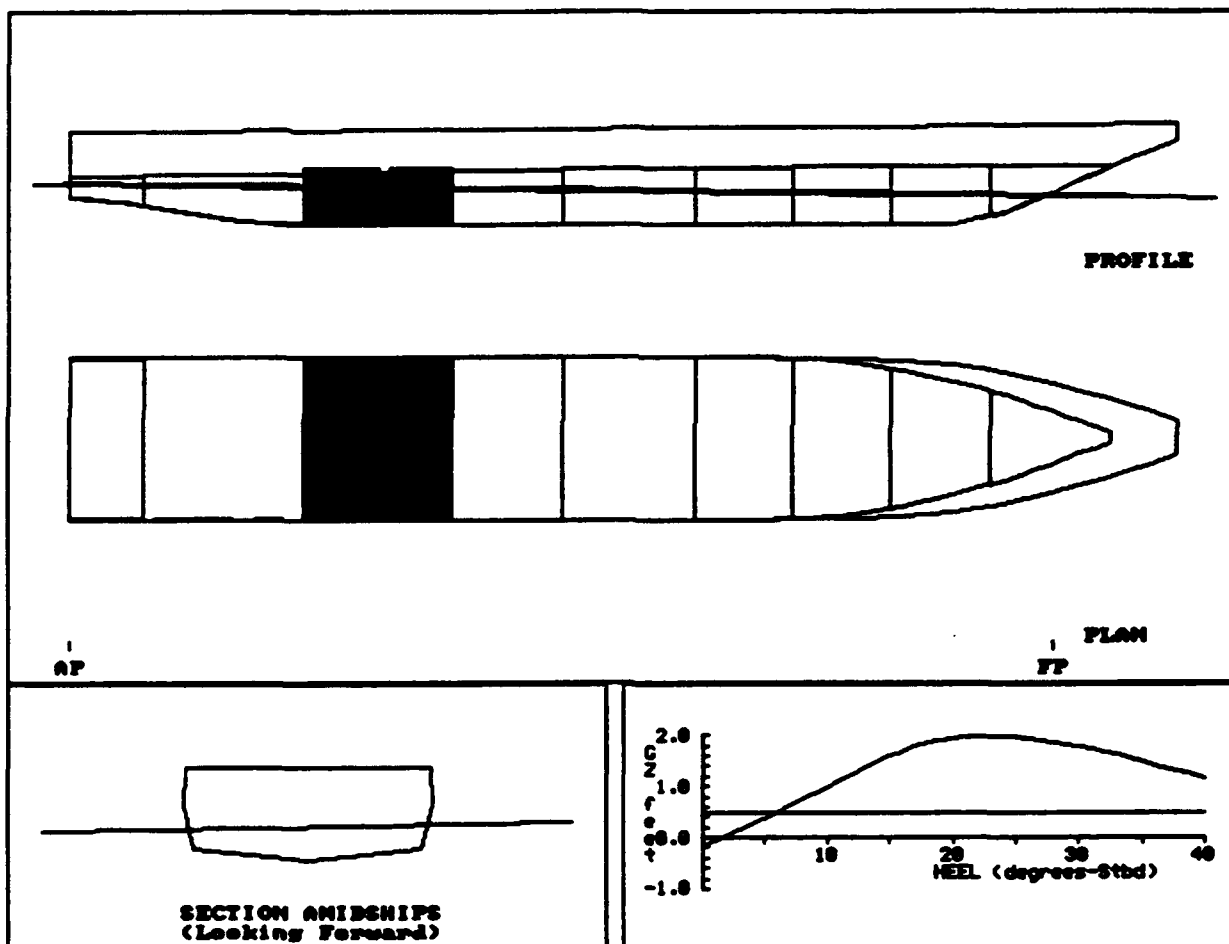

DPRT014A: LAVS/SEW/FUEL
 200' DINNER BOAT

COMPARTMENT FLOODING SUMMARY

At 1.6oS Heel	PERM.	FLOODED WTR LTons	% FULL (Damaged)	% FULL (Intact)	SP.VOL. ft ³ /LT	OUTFLOW LTons
LAVS	0.95	126	FREE	0.0	----	----
SEW TANK	0.95	17	FREE	10.0	35.0063	2
FUEL PORT	0.95	10	FREE	100.0	39.0000	19
Totals		153				20

INTACT DATA

Draft at AP = 9.080 ft	KMT = 28.137 ft	LCG = 85.794A ft-FP
Draft at FP = 7.710 ft	VCG = 20.890 ft	LCB = 85.925A ft-FP
Displacement = 782 LTons	GMT = 7.247 ft	TCG = 0.000 ft-CL

DRAFT/GZ DATA

HEEL degrees	RIGHTING ARM ft	DRAFT AFT ft	DRAFT FWD ft	FLOODED WATER LTons
0.0	-0.176	10.697	7.628	154
5.0S	0.386	10.658	7.591	151
7.0S	0.619	10.621	7.581	149
10.0S	0.983	10.562	7.544	146
15.0S	1.595	10.317	7.518	139
20.0S	1.944	9.894	7.359	127
22.0S	1.983	9.660	7.260	123
27.0S	1.916	8.942	6.898	112
30.0S	1.793	8.397	6.613	106
35.0S	1.498	7.280	6.021	96
40.0S	1.145	5.884	5.222	87

Note: Drafts are measured at A.P. and F.P along ship's centerline

GZ SUMMARY (Evaluated per IMO (SOLAS'90) Rules for Passenger Ships)
 Available Required

Static Heel Angle	1.6S deg	7.0 deg
Angle at Maximum GZ	24.0S deg	
Maximum GZ	1.986 ft	0.480 ft
Range of Positive GZ	38.4 deg	15.0 deg
Righting Area (1.6-22.0)	23.47 ft-deg	2.82 ft-deg

DPRT015A: LAVS/SEW/FUEL/H2O
 200' DINNER BOAT

Damaged Compartments:

	LAVS	SEW TANK	FRESH H2O P	FUEL PORT					
	DISPLACEMENT				DRAFT AFT	DRAFT FWD	TRIM	HEEL	UPRIGHT GHT
	LTONS				ft	ft	ft	deg.	ft
INTACT	782				9.080	7.710	1.370A	0.0	7.247
DAMAGED	900				10.539	7.577	2.962A	3.8S	5.836

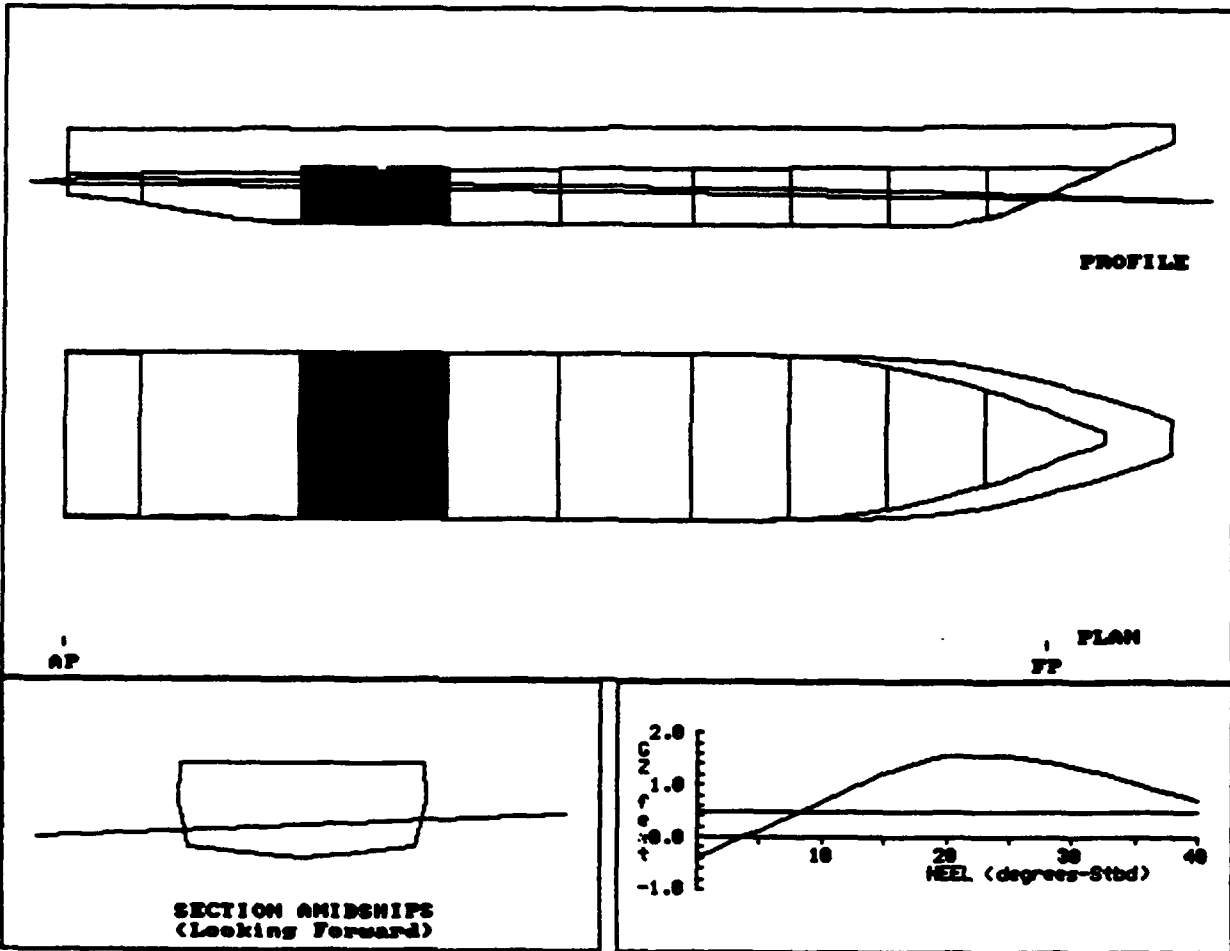

DPRT015A: LAVS/SEW/FUEL/H2O
 200' DINNER BOAT

COMPARTMENT FLOODING SUMMARY

At 3.8oS Heel	PERM.	FLOODED WTR LTons	% FULL (Damaged)	% FULL (Intact)	SP.VOL. ft3/LT	OUTFLOW LTons
LAVS	0.95	124	FREE	0.0	----	----
SEW TANK	0.95	17	FREE	10.0	35.0063	2
FRESH H2O P	0.95	6	FREE	100.0	35.0063	17
FUEL PORT	0.95	8	FREE	100.0	39.0000	19
Totals		155				37

INTACT DATA

Draft at AP = 9.080 ft KMT = 28.137 ft LCG = 85.794A ft-FP
 Draft at FP = 7.710 ft VCG = 20.890 ft LCB = 85.925A ft-FP
 Displacement = 782 LTons GMT = 7.247 ft TCG = 0.000 ft-CL

DRAFT/GZ DATA

HEEL degrees	RIGHTING ARM ft	DRAFT AFT ft	DRAFT FWD ft	FLOODED WATER LTons
0.0	-0.386	10.583	7.614	160
5.0S	0.130	10.516	7.569	154
7.0S	0.345	10.464	7.561	151
10.0S	0.679	10.384	7.524	146
15.0S	1.230	10.092	7.507	136
20.0S	1.550	9.636	7.350	124
22.0S	1.581	9.391	7.253	120
27.0S	1.495	8.647	6.893	109
30.0S	1.363	8.087	6.609	104
35.0S	1.055	6.944	6.019	94
40.0S	0.694	5.521	5.222	85

Note: Drafts are measured at A.P. and F.P along ship's centerline

GZ SUMMARY (Evaluated per IMO (SOLAS'90) Rules for Passenger Ships)

	Available	Required
Static Heel Angle	3.8S deg	7.0 deg
Angle at Maximum GZ	23.0S deg	
Maximum GZ	1.581 ft	0.480 ft
Range of Positive GZ	36.2 deg	15.0 deg
Righting Area (3.8-22.0)	17.12 ft-deg	2.82 ft-deg

RTRN001B: FPK/THRUSTER
 200' DINNER BOAT

Imaged Compartments:
 FOREPEAK BOWTHRUST

	DISPLACEMENT LTons	DRAFT AFT ft	DRAFT FWD ft	TRIM ft	HEEL deg.	UPRIGHT GMT ft
INTACT	754	8.750	7.710	1.040A	0.0	7.602
DAMAGED	801	8.171	9.090	0.919F	0.0	7.321

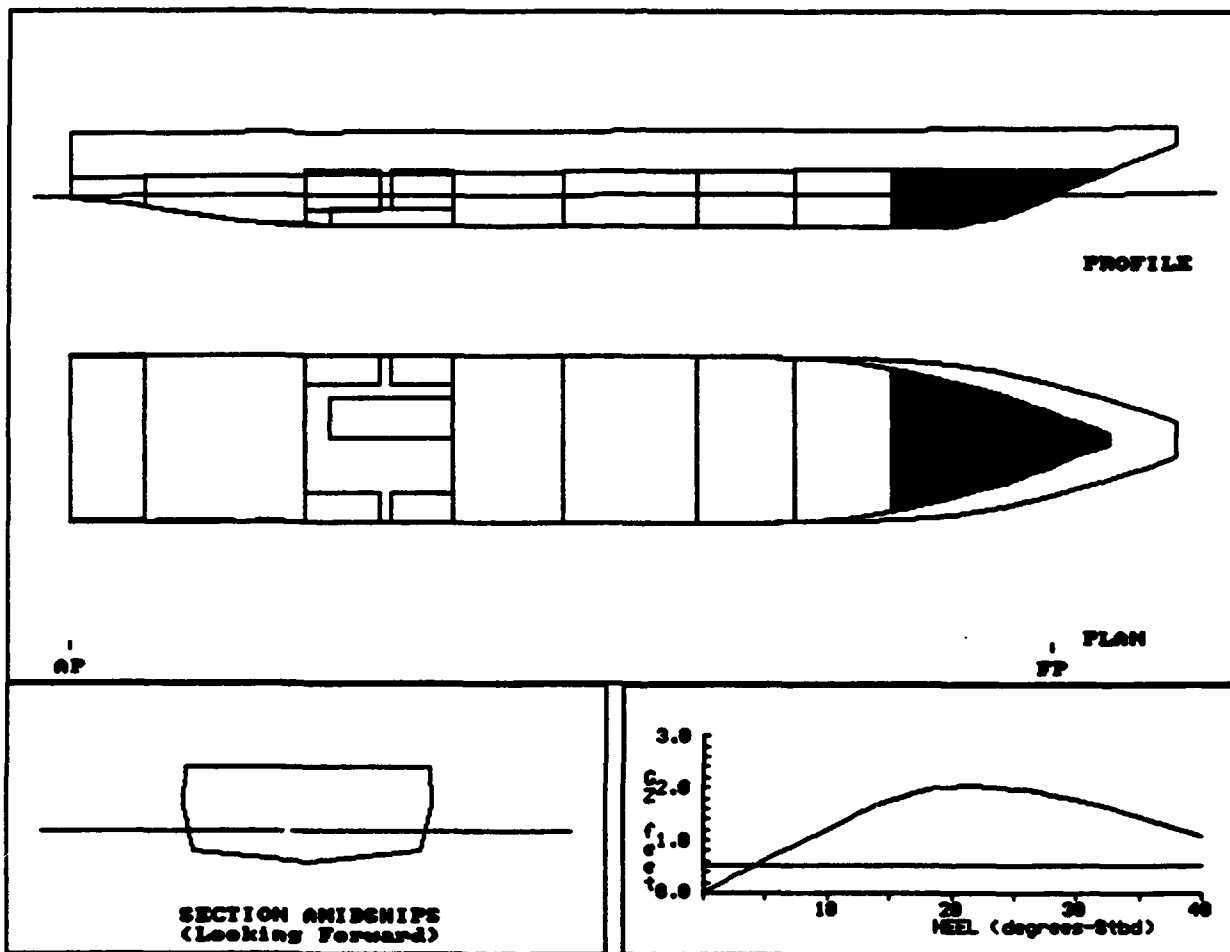

RTRN001B: FPK/THRUSTER
 200' DINNER BOAT

COMPARTMENT FLOODING SUMMARY

At 0.0o Heel	PERM.	FLOODED WTR LTons	% FULL (Damaged)	% FULL (Intact)	SP.VOL. ft3/LT	OUTFLOW LTons
FOREPEAK	0.95	5	FREE	0.0	----	----
BOWTHRUST	0.85	42	FREE	0.0	----	----
Totals		47				

INTACT DATA

Draft at AP = 8.750 ft	Kmt = 28.742 ft	LCG = 84.985A ft-FP
Draft at FP = 7.710 ft	VCG = 21.140 ft	LCB = 85.086A ft-FP
Displacement = 754 LTons	Gmt = 7.602 ft	TCG = 0.000 ft-CL

DRAFT/GZ DATA

HEEL degrees	RIGHTING ARM ft	DRAFT AFT ft	DRAFT FWD ft	FLOODED WATER LTons
0.0	0.000	8.171	9.090	47
5.0S	0.614	8.090	9.131	48
7.0S	0.848	8.025	9.156	48
10.0S	1.198	7.898	9.196	49
15.0S	1.755	7.548	9.307	51
20.0S	2.014	6.988	9.325	53
22.0S	2.028	6.730	9.269	53
27.0S	1.916	5.913	9.036	53
30.0S	1.775	5.349	8.787	52
35.0S	1.460	4.260	8.178	49
40.0S	1.094	2.941	7.302	45

Note: Drafts are measured at A.P. and F.P along ship's centerline

GZ SUMMARY (Evaluated per IMO (SOLAS'90) Rules for Passenger Ships)

	Available	Required
Static Heel Angle	0.0 deg	7.0 deg
Angle at Maximum GZ	23.0S deg	
Maximum GZ	2.028 ft	0.500 ft
Range of Positive GZ	40.0 deg	15.0 deg
Gmt (upright damaged)	7.321 ft	
Righting Area (0.0-22.0)	27.13 ft-deg	2.82 ft-deg

RTRM002B: THRUSTER/STOR1
 200' DINNER BOAT

Imaged Compartments:
 BOWTHRUST STORAGE1

	DISPLACEMENT LTONS	DRAFT AFT ft	DRAFT FWD ft	TRIM ft	HEEL deg.	UPRIGHT GMT ft
INTACT	754	8.750	7.710	1.040A	0.0	7.602
DAMAGED	942	6.933	12.398	5.464F	0.0	5.053

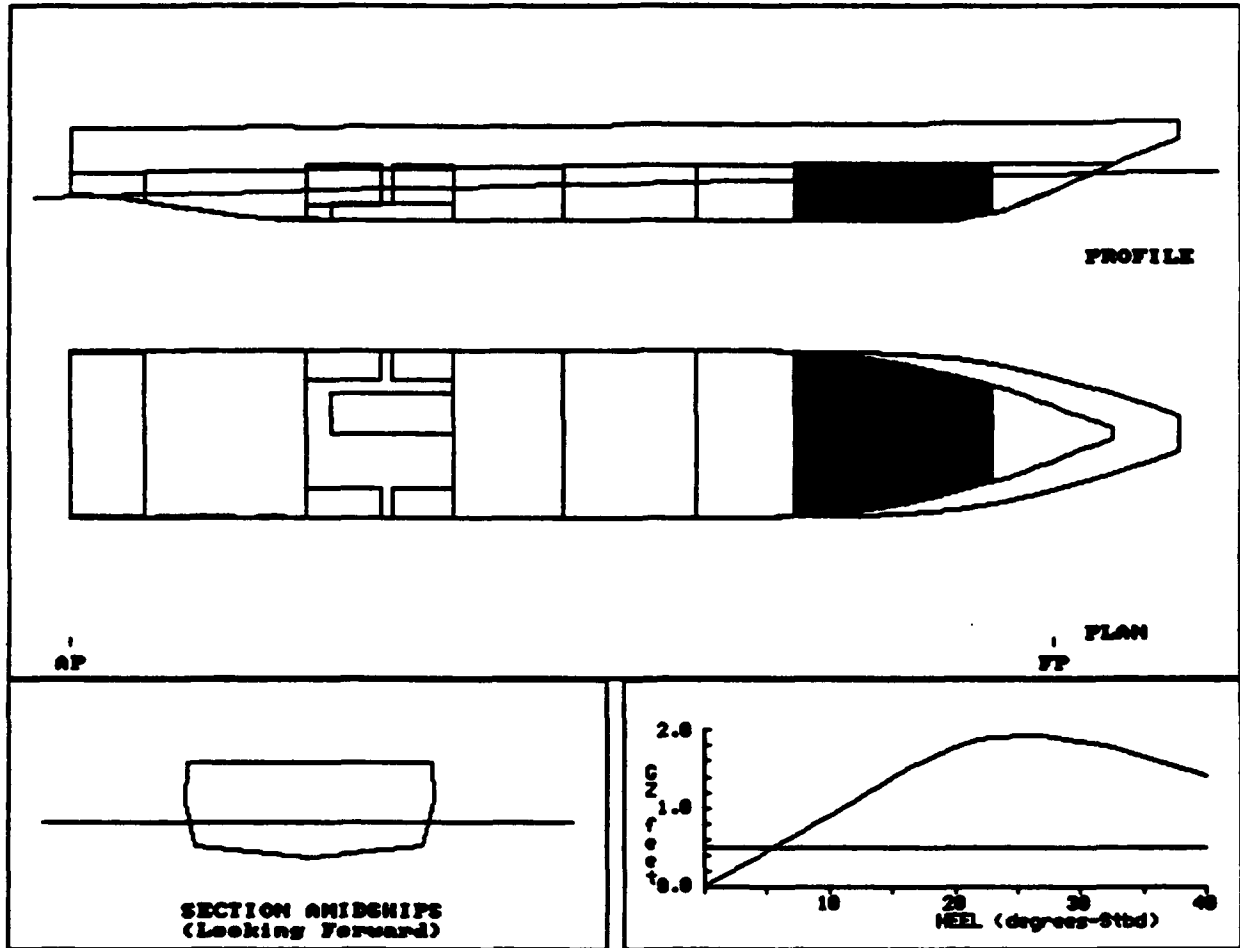

RTRN002B: THRUSTER/STOR1
 200' DINNEN BOAT

COMPARTMENT FLOODING SUMMARY

At 0.0o Heel	PERM.	FLOODED WTR LTons	% FULL (Damaged)	% FULL (Intact)	SP.VOL. ft3/LT	OUTFLOW LTons
BOWTHRUST	0.85	68	FREE	0.0	----	----
STORAGE1	0.95	120	FREE	0.0	----	----
Totals		188				

INTACT DATA

Draft at AP = 8.750 ft Kmt = 28.742 ft LCG = 84.985A ft-FP
 Draft at FP = 7.710 ft VCG = 21.140 ft LCB = 85.086A ft-FP
 Displacement = 754 LTons GMT = 7.602 ft TCG = 0.000 ft-CL

DRAFT/GZ DATA

HEEL degrees	RIGHTING ARM ft	DRAFT AFT ft	DRAFT FWD ft	FLOODED WATER LTons
0.0	0.000	6.933	12.398	188
5.0S	0.446	6.843	12.446	189
7.0S	0.627	6.753	12.494	190
10.0S	0.899	6.583	12.569	192
15.0S	1.383	6.224	12.637	193
20.0S	1.782	5.723	12.558	187
22.0S	1.872	5.478	12.473	184
27.0S	1.923	4.725	12.142	173
30.0S	1.864	4.197	11.834	166
35.0S	1.670	3.139	11.162	155
40.0S	1.410	1.839	10.238	143

Note: Drafts are measured at A.P. and F.P along ship's centerline

GZ SUMMARY (Evaluated per IMO (SOLAS'90) Rules for Passenger Ships)

	Available	Required
Static Heel Angle	0.0 deg	7.0 deg
Angle at Maximum GZ	27.0S deg	
Maximum GZ	1.929 ft	0.500 ft
Range of Positive GZ	40.0 deg	15.0 deg
Gmt (upright damaged)	5.053 ft	
Righting Area (0.0-22.0)	21.82 ft-deg	2.82 ft-deg

RTRN003B: STOR 1/PREP
 200' DINNER BOAT

Imaged Compartments:
 STORAGE1 PREP RM

	DISPLACEMENT LTons	DRAFT AFT ft	DRAFT FWD ft	TRIM ft	HEEL deg.	UPRIGHT GMT ft
INTACT	754	8.750	7.710	1.040A	0.0	7.602
DAMAGED	1,028	7.236	13.212	5.976F	0.0	4.100

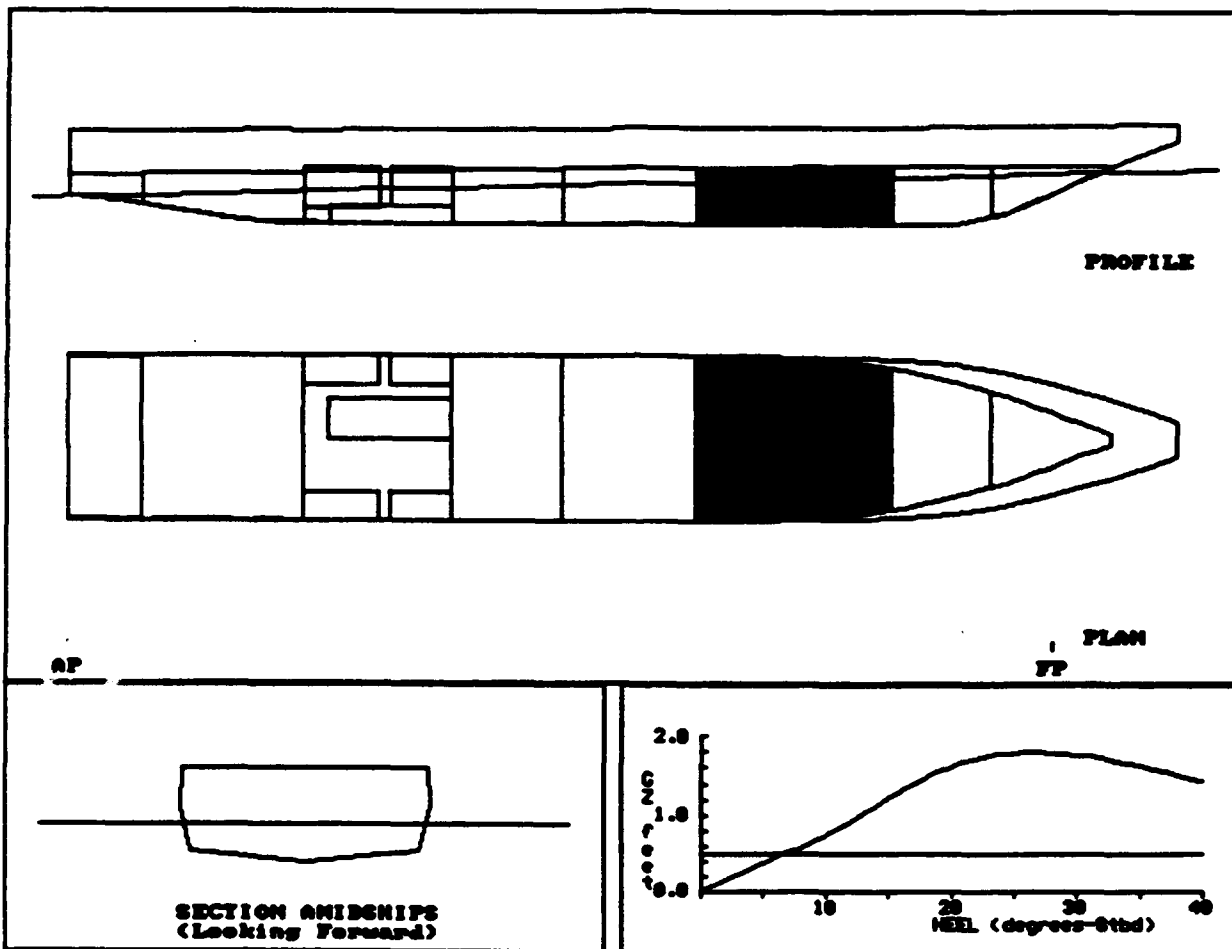

RTRM003B: STOR 1/PREP
 200' DINNER BOAT

COMPARTMENT FLOODING SUMMARY

At 0.0o Heel	PERM.	FLOODED WTR LTons	% FULL (Damaged)	% FULL (Intact)	SP.VOL. ft3/LT	OUTFLOW LTons
STORAGE1	0.95	131	FREE	0.0	----	----
PREP RM	0.95	144	FREE	0.0	----	----
Totals		274				

INTACT DATA

Draft at AP = 8.750 ft KMT = 28.742 ft LCG = 84.985A ft-FP
 Draft at FP = 7.710 ft VCG = 21.140 ft LCB = 85.086A ft-FP
 Displacement = 754 LTons GMT = 7.602 ft TCG = 0.000 ft-CL

DRAFT/GZ DATA

HEEL degrees	RIGHTING ARM ft	DRAFT AFT ft	DRAFT FWD ft	FLOODED WATER LTons
0.0	0.000	7.236	13.212	274
5.0S	0.364	7.155	13.241	275
7.0S	0.510	7.082	13.263	275
10.0S	0.732	6.944	13.293	276
15.0S	1.211	6.681	13.170	268
20.0S	1.622	6.260	12.961	254
22.0S	1.718	6.039	12.839	248
27.0S	1.799	5.328	12.452	231
30.0S	1.769	4.810	12.137	222
35.0S	1.631	3.751	11.478	207
40.0S	1.427	2.450	10.581	192

Note: Drafts are measured at A.P. and F.P along ship's centerline

GZ SUMMARY (Evaluated per IMO (SOLAS'90) Rules for Passenger Ships)

	Available	Required
Static Heel Angle	0.0 deg	7.0 deg
Angle at Maximum GZ	28.0S deg	
Maximum GZ	1.799 ft	0.500 ft
Range of Positive GZ	40.0 deg	15.0 deg
Gmt (upright damaged)	4.100 ft	
Righting Area (0.0-22.0)	18.97 ft-deg	2.82 ft-deg

RTRM004B: PREP/STOR 2
 200' DINNER BOAT

Imaged Compartments:
 PREP RM STORAGE2

	DISPLACEMENT LTONS	DRAFT AFT ft	DRAFT FWD ft	TRIM ft	HEEL deg.	UPRIGHT GMT ft
INTACT	754	8.750	7.710	1.040A	0.0	7.602
DAMAGED	1,084	8.554	12.474	3.920F	0.0	3.947

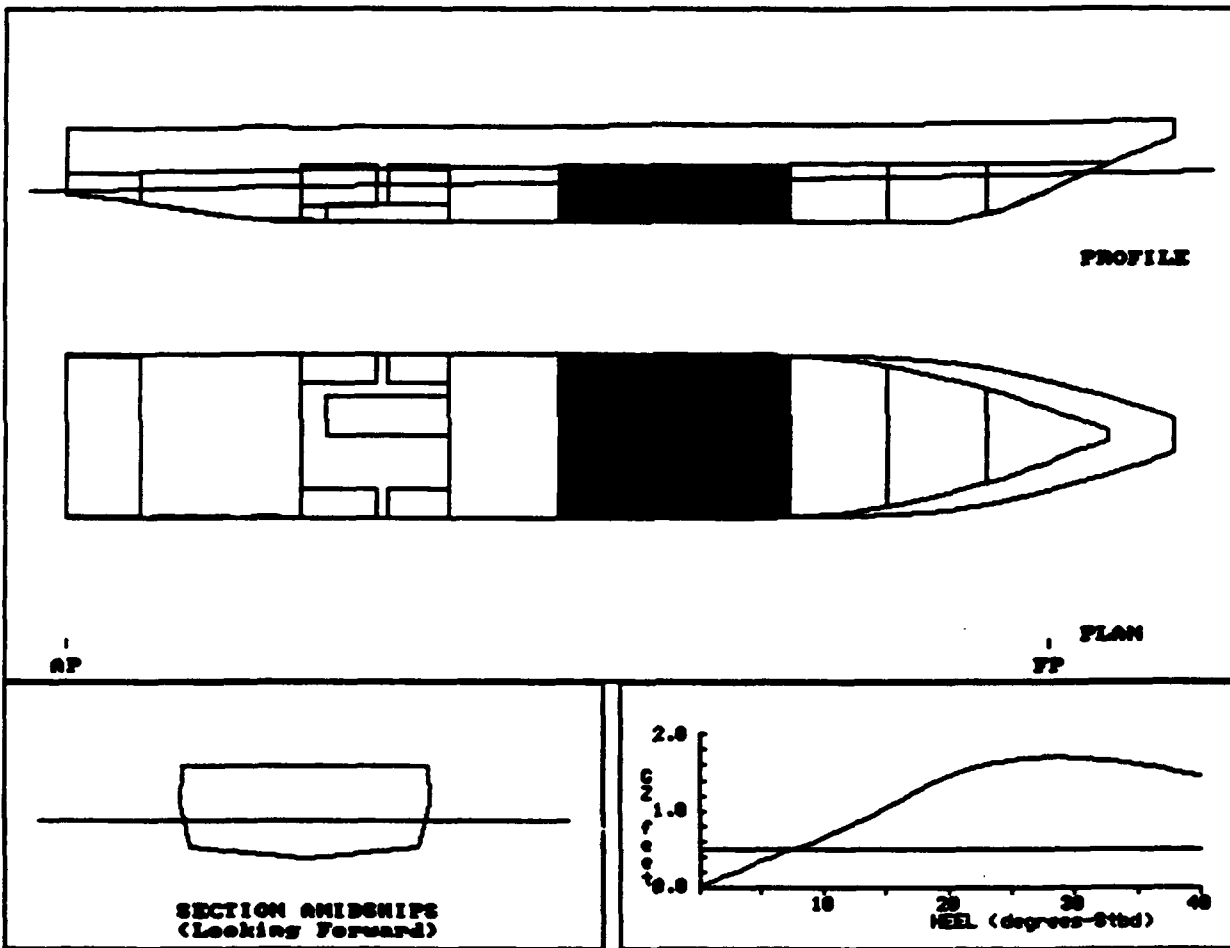

RTRN004B: PREP/STOR 2
 200' DINNER BOAT

COMPARTMENT FLOODING SUMMARY

At 0.0o Heel	PERM.	FLOODED WTR LTons	% FULL (Damaged)	% FULL (Intact)	SP.VOL. ft3/LT	OUTFLOW LTons
PREP RM	0.95	142	FREE	0.0	----	----
STORAGE2	0.95	188	FREE	0.0	----	----
Totals		330				

INTACT DATA

Draft at AP = 8.750 ft Kmt = 28.742 ft LCG = 84.985A ft-FP
 Draft at FP = 7.710 ft VCG = 21.140 ft LCB = 85.086A ft-FP
 Displacement = 754 LTons Gmt = 7.602 ft TCG = 0.000 ft-CL

DRAFT/GZ DATA

HEEL degrees	RIGHTING ARM ft	DRAFT AFT ft	DRAFT FWD ft	FLOODED WATER LTons
0.0	0.000	8.554	12.474	330
5.0S	0.334	8.524	12.462	330
7.0S	0.458	8.484	12.455	329
10.0S	0.641	8.394	12.443	329
15.0S	1.038	8.161	12.341	321
20.0S	1.450	7.796	12.100	303
22.0S	1.559	7.579	11.995	295
27.0S	1.693	6.905	11.604	276
30.0S	1.693	6.394	11.302	266
35.0S	1.606	5.356	10.657	249
40.0S	1.455	4.045	9.797	232

Note: Drafts are measured at A.P. and F.P along ship's centerline

GZ SUMMARY (Evaluated per IMO (SOLAS'90) Rules for Passenger Ships)

	Available	Required
Static Heel Angle	0.0 deg	7.0 deg
Angle at Maximum GZ	29.0S deg	
Maximum GZ	1.699 ft	0.500 ft
Range of Positive GZ	40.0 deg	15.0 deg
Gmt (upright damaged)	3.947 ft	
Righting Area (0.0-22.0)	16.71 ft-deg	2.82 ft-deg

RTRN005B: AC MACHY
 200' DINNER BOAT

Imaged Compartments:
 AC MACHY

	DISPLACEMENT LTons	DRAFT AFT ft	DRAFT FWD ft	TRIM ft	HEEL deg.	UPRIGHT GMT ft
INTACT	754	8.750	7.710	1.040A	0.0	7.602
DAMAGED	861	9.451	8.373	1.077A	0.0	5.765

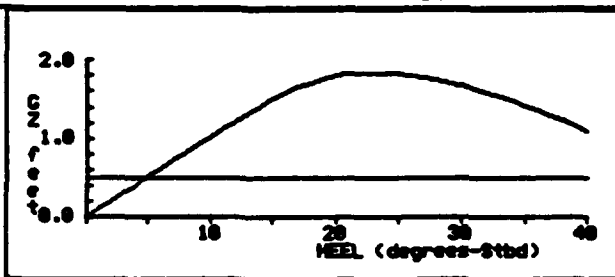
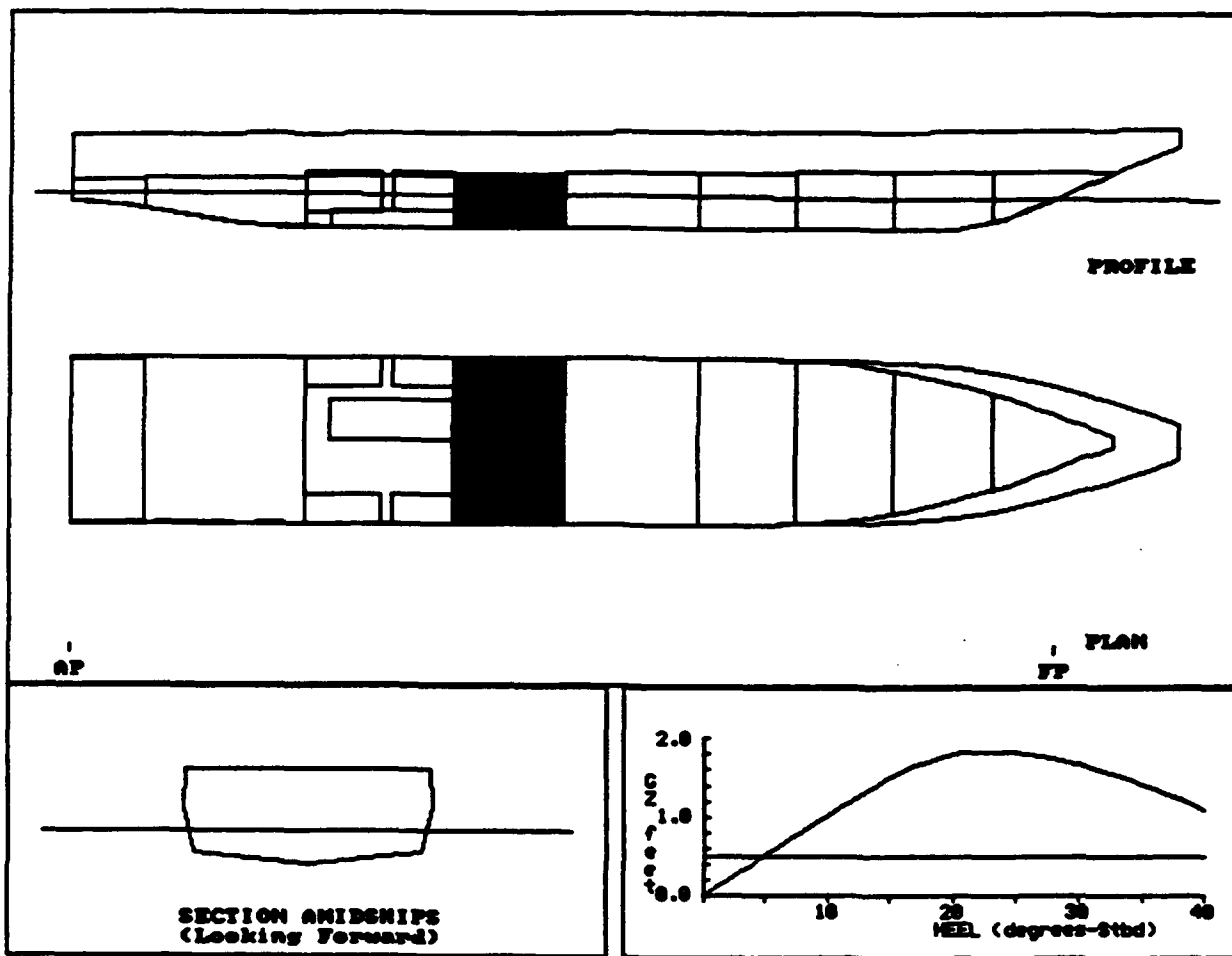

RTRN005B: AC MACHY
 200' DINNER BOAT

COMPARTMENT FLOODING SUMMARY

At 0.0o Heel	PERM.	FLOODED WTR LTons	% FULL (Damaged)	% FULL (Intact)	SP.VOL. ft3/LT	OUTFLOW LTons
AC MACHY	0.85	107	FREE	0.0	----	----
Totals		107				

INTACT DATA

Draft at AP = 8.750 ft	KMt = 28.742 ft	LCG = 84.985A ft-FP
Draft at FP = 7.710 ft	VCG = 21.140 ft	LCB = 85.086A ft-FP
Displacement = 754 LTons	Gmt = 7.602 ft	TCG = 0.000 ft-CL

DRAFT/GZ DATA

HEEL degrees	RIGHTING ARM ft	DRAFT AFT ft	DRAFT FWD ft	FLOODED WATER LTons
0.0	0.000	9.451	8.373	107
5.0S	0.509	9.445	8.346	107
7.0S	0.712	9.423	8.333	107
10.0S	1.012	9.359	8.314	106
15.0S	1.512	9.136	8.308	105
20.0S	1.800	8.743	8.176	102
22.0S	1.837	8.521	8.081	101
27.0S	1.783	7.830	7.729	96
30.0S	1.675	7.306	7.451	93
35.0S	1.416	6.263	6.831	88
40.0S	1.096	4.917	6.019	83

Note: Drafts are measured at A.P. and F.P along ship's centerline

GZ SUMMARY (Evaluated per IMO (SOLAS'90) Rules for Passenger Ships)
 Available Required

Static Heel Angle	0.0 deg	7.0 deg
Angle at Maximum GZ	24.0S deg	
Maximum GZ	1.841 ft	0.500 ft
Range of Positive GZ	40.0 deg	15.0 deg
Gmt (upright damaged)	5.765 ft	
Righting Area (0.0-22.0)	23.46 ft-deg	2.82 ft-deg

RTRN006B: LAVS
 200' DINNER BOAT

Imaged Compartments:
 LAVS

	DISPLACEMENT LTons	DRAFT AFT ft	DRAFT FWD ft	TRIM ft	HEEL deg.	UPRIGHT Gmt ft
INTACT	754	8.750	7.710	1.040A	0.0	7.602
DAMAGED	875	10.234	7.603	2.632A	0.8S	6.993

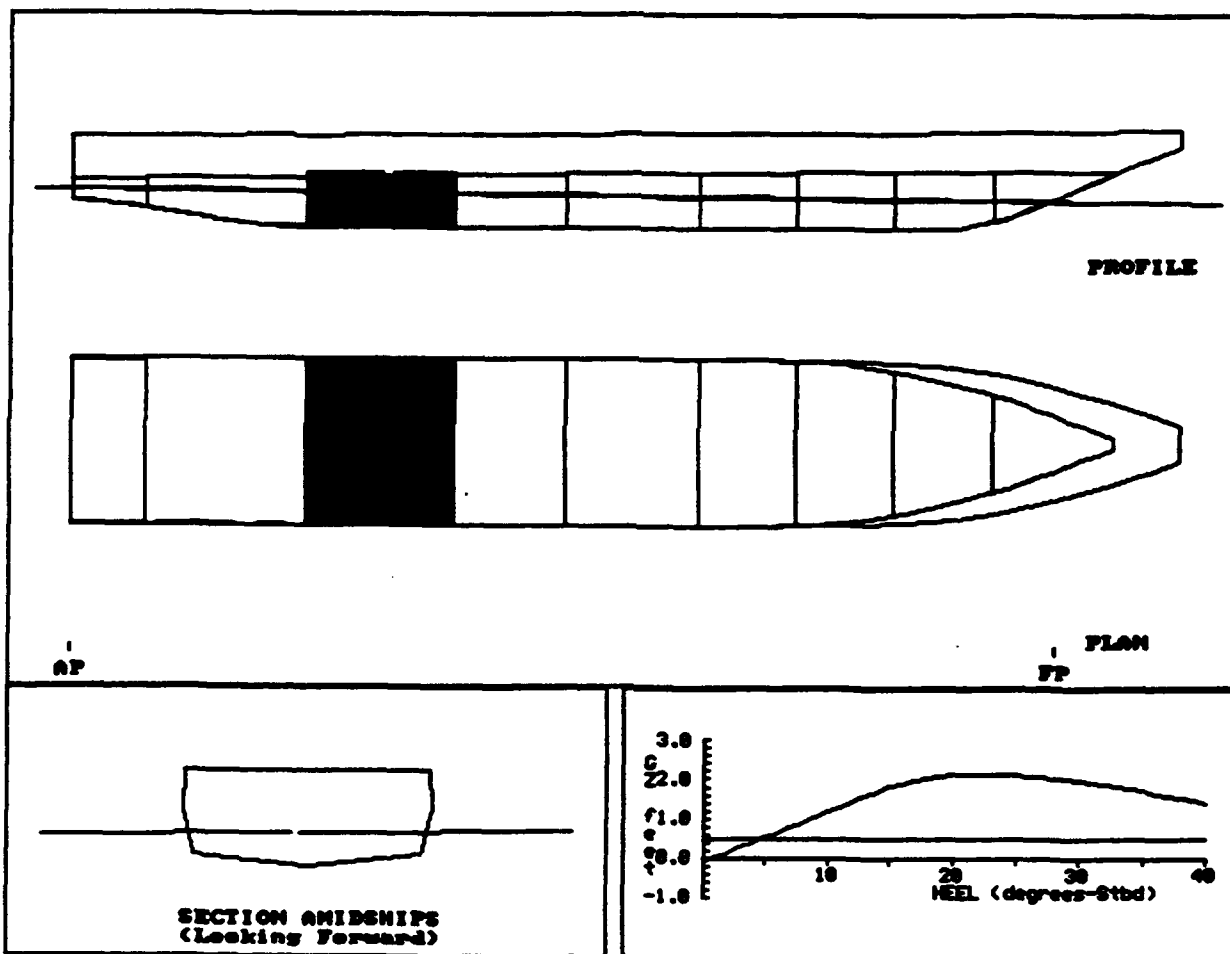

RTRN006B: LAVS
 200' DINNER BOAT

COMPARTMENT FLOODING SUMMARY

At 0.8oS Heel	PERM.	FLOODED WTR LTons	% FULL (Damaged)	% FULL (Intact)	SP.VOL. ft3/LT	OUTFLOW LTons
LAVS	0.95	121	FREE	0.0	----	----
Totals		121				

INTACT DATA

Draft at AP = 8.750 ft	Kmt = 28.742 ft	LCG = 84.985A ft-FP
Draft at FP = 7.710 ft	VCG = 21.140 ft	LCB = 85.086A ft-FP
Displacement = 754 LTons	Gmt = 7.602 ft	TCG = 0.000 ft-CL

DRAFT/GZ DATA

HEEL degrees	RIGHTING ARM ft	DRAFT AFT ft	DRAFT FWD ft	FLOODED WATER LTons
0.0	-0.100	10.233	7.608	121
5.0S	0.518	10.233	7.573	121
7.0S	0.774	10.218	7.556	120
10.0S	1.163	10.176	7.521	120
15.0S	1.803	9.964	7.490	116
20.0S	2.115	9.517	7.328	105
22.0S	2.134	9.269	7.231	101
27.0S	2.062	8.555	6.868	93
30.0S	1.962	8.038	6.579	90
35.0S	1.705	6.977	5.978	85
40.0S	1.394	5.643	5.170	80

Note: Drafts are measured at A.P. and F.P along ship's centerline

GZ SUMMARY (Evaluated per IMO (SOLAS'90) Rules for Passenger Ships)
 Available Required

Static Heel Angle	0.8S deg	7.0 deg
Angle at Maximum GZ	23.0S deg	
Maximum GZ	2.134 ft	0.500 ft
Range of Positive GZ	39.2 deg	15.0 deg
Righting Area (0.8-22.0)	26.96 ft-deg	2.82 ft-deg

RTRN007B: ENGINE ROOM
 200' DINNER BOAT

Imaged Compartments:
 ENGINE ROOM

	DISPLACEMENT LTons	DRAFT AFT ft	DRAFT FWD ft	TRIM ft	HEEL deg.	UPRIGHT GMT ft
INTACT	754	8.750	7.710	1.040A	0.0	7.602
DAMAGED	923	11.942	6.162	5.780A	0.0	4.710

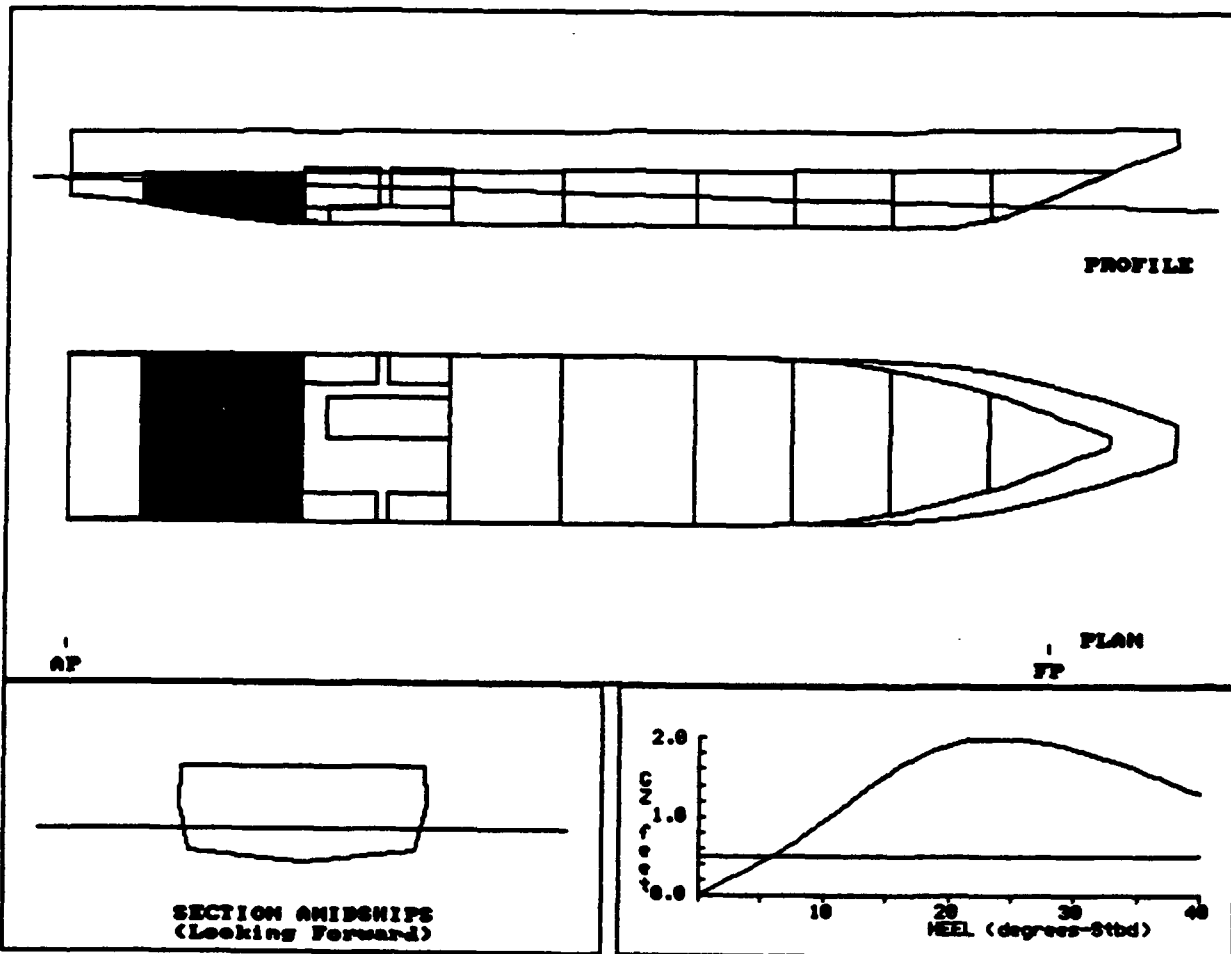

RTRN007B: ENGINE ROOM
 200' DINNER BOAT

COMPARTMENT FLOODING SUMMARY

At 0.0o Heel	PERM.	FLOODED WTR LTons	% FULL (Damaged)	% FULL (Intact)	SP.VOL. ft3/LT	OUTFLOW LTons
ENGINE ROOM	0.85	169	FREE	0.0	----	----
Totals		169				

INTACT DATA

Draft at AP = 8.750 ft	KMt = 28.742 ft	LCG = 84.985A ft-FP
Draft at FP = 7.710 ft	VCG = 21.140 ft	LCB = 85.086A ft-FP
Displacement = 754 LTons	GMT = 7.602 ft	TCG = 0.000 ft-CL

DRAFT/GZ DATA

HEEL degrees	RIGHTING ARM ft	DRAFT AFT ft	DRAFT FWD ft	FLOODED WATER LTons
0.0	0.000	11.942	6.162	169
5.0S	0.417	11.940	6.133	170
7.0S	0.600	11.921	6.118	169
10.0S	0.931	11.816	6.125	165
15.0S	1.523	11.561	6.089	154
20.0S	1.909	11.157	5.931	142
22.0S	1.971	10.926	5.839	137
27.0S	1.957	10.225	5.485	126
30.0S	1.860	9.679	5.221	120
35.0S	1.604	8.575	4.654	110
40.0S	1.281	7.195	3.880	101

Note: Drafts are measured at A.P. and F.P along ship's centerline

GZ SUMMARY (Evaluated per IMO (SOLAS'90) Rules for Passenger Ships)

	Available	Required
Static Heel Angle	0.0 deg	7.0 deg
Angle at Maximum GZ	25.0S deg	
Maximum GZ	1.991 ft	0.500 ft
Range of Positive GZ	40.0 deg	15.0 deg
Gmt (upright damaged)	4.710 ft	
Righting Area (0.0-22.0)	23.08 ft-deg	2.82 ft-deg

RTRN008B: LAZARETTE
 200' DINNER BOAT

Imaged Compartments:
 LAZARETTE

	DISPLACEMENT LTons	DRAFT AFT ft	DRAFT FWD ft	TRIM ft	HEEL deg.	UPRIGHT GMT ft
INTACT	754	8.750	7.710	1.040A	0.0	7.602
DAMAGED	778	9.333	7.336	1.997A	0.0	5.761

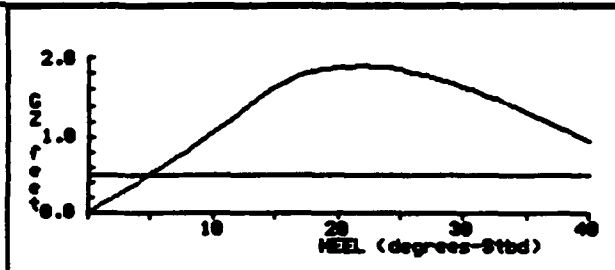
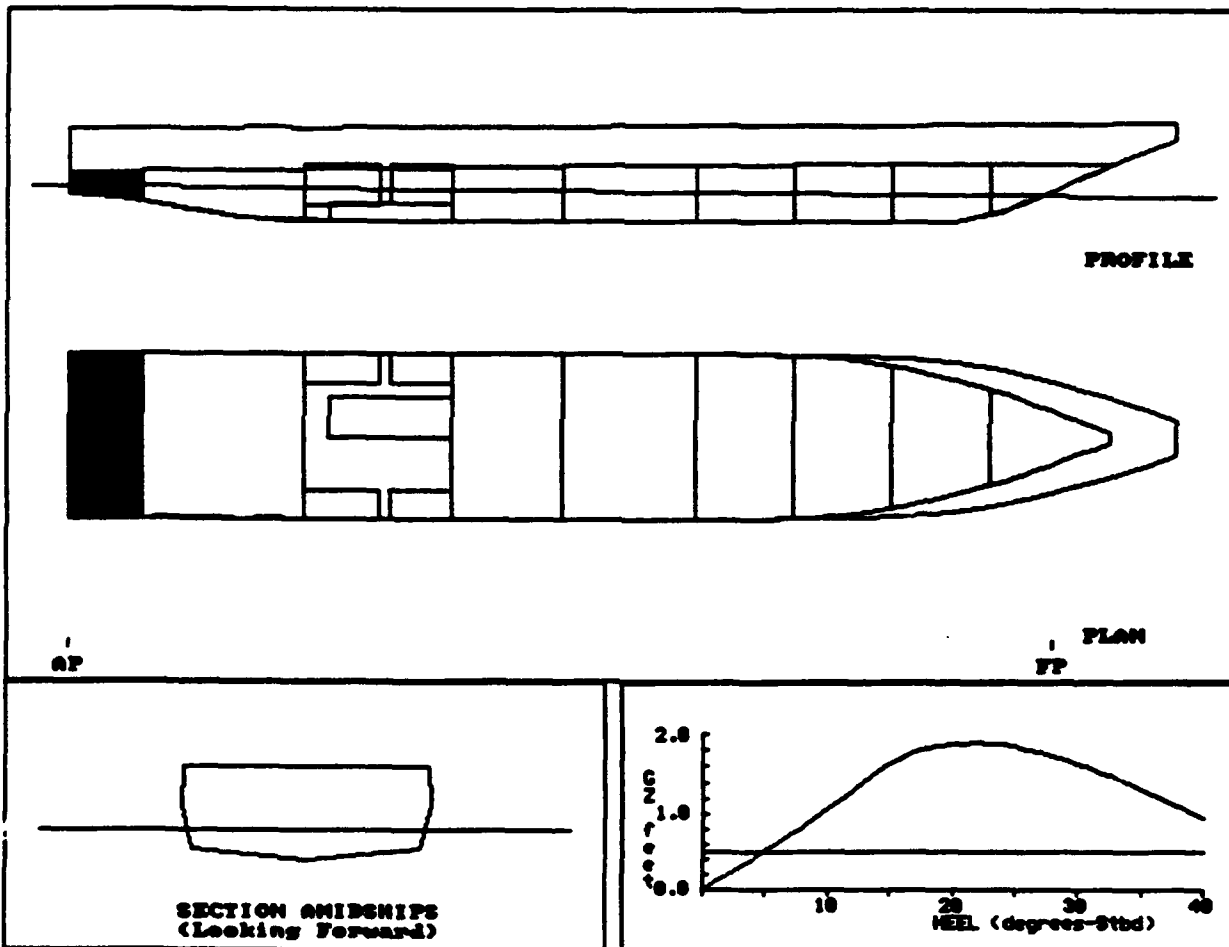

**RTRN008B: LAZARETTE
 200' DINNER BOAT**

COMPARTMENT FLOODING SUMMARY

At 0.0o Heel	PERM.	FLOODED WTR LTons	‡ FULL (Damaged)	‡ FULL (Intact)	SP.VOL. ft3/LT	OUTFLOW LTons
LAZARETTE	0.95	24	FREE	0.0	----	----
Totals		24				

INTACT DATA

Draft at AP = 8.750 ft	KMt = 28.742 ft	LCG = 84.985A ft-FP
Draft at FP = 7.710 ft	VCG = 21.140 ft	LCB = 85.086A ft-FP
Displacement = 754 LTons	GMT = 7.602 ft	TCG = 0.000 ft-CL

DRAFT/GZ DATA

HEEL degrees	RIGHTING ARM ft	DRAFT AFT ft	DRAFT FWD ft	FLOODED WATER LTons
0.0	0.000	9.333	7.336	24
5.0S	0.509	9.331	7.308	24
7.0S	0.722	9.322	7.289	25
10.0S	1.054	9.300	7.247	27
15.0S	1.626	9.115	7.195	28
20.0S	1.882	8.710	7.016	28
22.0S	1.897	8.480	6.913	27
27.0S	1.782	7.761	6.558	26
30.0S	1.636	7.249	6.251	25
35.0S	1.312	6.163	5.658	24
40.0S	0.935	4.816	4.852	22

Note: Drafts are measured at A.P. and F.P along ship's centerline

GZ SUMMARY (Evaluated per IMO (SOLAS'90) Rules for Passenger Ships)

	Available	Required
Static Heel Angle	0.0 deg	7.0 deg
Angle at Maximum GZ	23.0S deg	
Maximum GZ	1.897 ft	0.500 ft
Range of Positive GZ	40.0 deg	15.0 deg
Gmt (upright damaged)	5.761 ft	
Righting Area (0.0-22.0)	24.60 ft-deg	2.82 ft-deg

RTRN009B: LAVS/FUEL
 200' DINNER BOAT

Damaged Compartments:
 LAVS FUEL PORT

	DISPLACEMENT LTons	DRAFT AFT ft	DRAFT FWD ft	TRIM ft	HEEL deg.	UPRIGHT GMT ft
INTACT	754	8.750	7.710	1.040A	0.0	7.602
DAMAGED	885	10.369	7.580	2.789A	0.7P	6.317

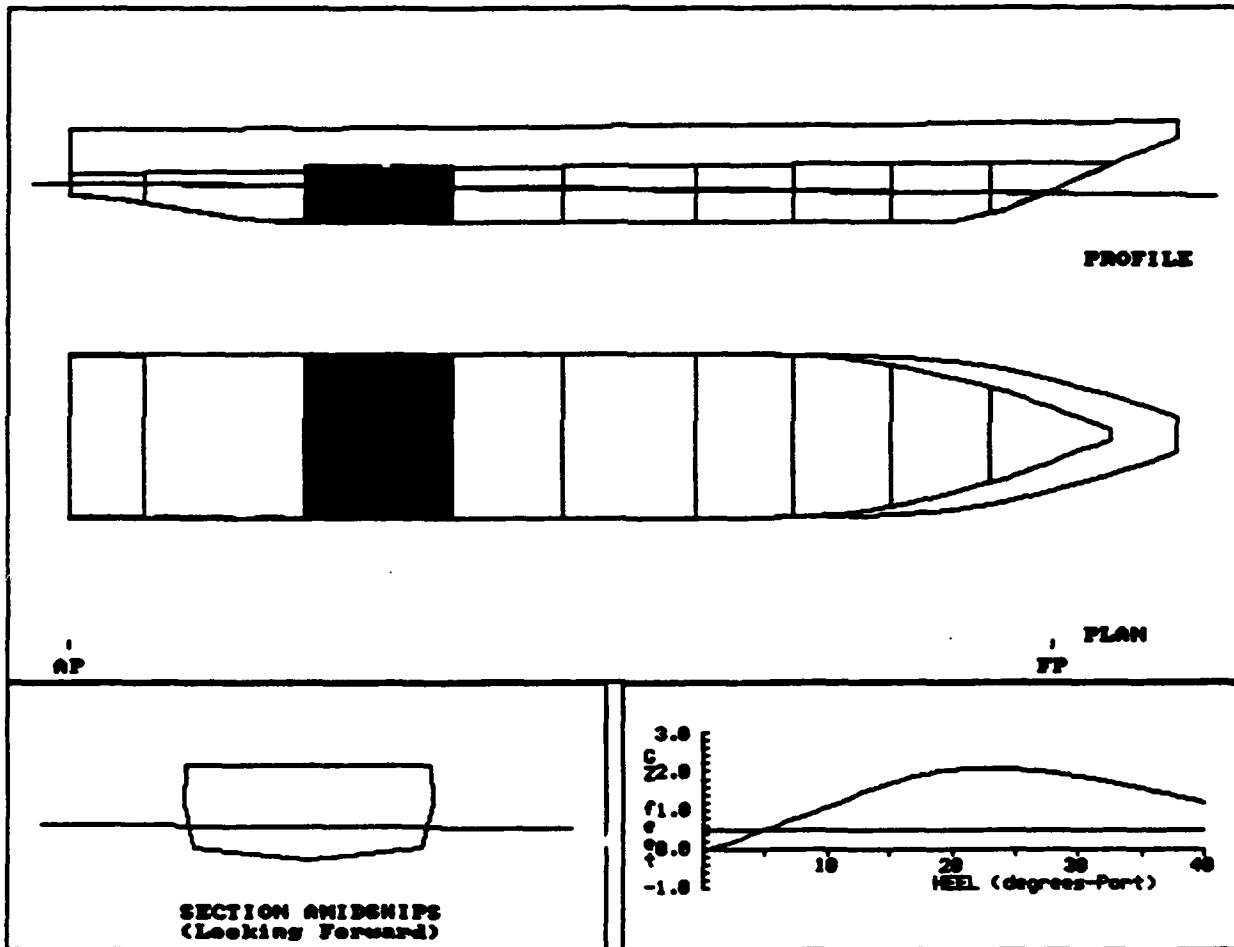

RTRN009B: LAVS/FUEL
 200' DINNER BOAT

COMPARTMENT FLOODING SUMMARY

At 0.7oP Heel	PERM.	FLOODED WTR LTons	% FULL (Damaged)	% FULL (Intact)	SP.VOL. ft3/LT	OUTFLOW LTons
LAVS	0.95	122	FREE	0.0	----	----
FUEL PORT	0.95	10	FREE	10.0	39.0000	2
Totals		133				2

INTACT DATA

Draft at AP = 8.750 ft KMT = 28.742 ft LCG = 84.985A ft-FP
 Draft at FP = 7.710 ft VCG = 21.140 ft LCB = 85.086A ft-FP
 Displacement = 754 LTons GMT = 7.602 ft TCG = 0.000 ft-CL

DRAFT/GZ DATA

HEEL degrees	RIGHTING ARM ft	DRAFT AFT ft	DRAFT FWD ft	FLOODED WATER LTons
0.0	-0.073	10.363	7.585	132
5.0P	0.486	10.406	7.547	136
7.0P	0.719	10.414	7.522	137
10.0P	1.078	10.409	7.480	139
15.0P	1.691	10.273	7.421	139
20.0P	2.043	9.897	7.243	130
22.0P	2.076	9.665	7.140	126
27.0P	1.999	8.950	6.771	115
30.0P	1.869	8.407	6.480	109
35.0P	1.566	7.294	5.881	100
40.0P	1.204	5.902	5.074	91

Note: Drafts are measured at A.P. and F.P along ship's centerline

GZ SUMMARY (Evaluated per IMO (SOLAS'90) Rules for Passenger Ships)

	Available	Required
Static Heel Angle	0.7P deg	7.0 deg
Angle at Maximum GZ	24.0P deg	
Maximum GZ	2.077 ft	0.500 ft
Range of Positive GZ	39.3 deg	15.0 deg
Righting Area (0.7-22.0)	25.51 ft-deg	2.82 ft-deg

RTRN010B: LAVS/H2O
 200' DINNER BOAT

Used Compartments:
 LAVS FRESH H2O P

	DISPLACEMENT LTONS	DRAFT AFT ft	DRAFT FWD ft	TRIM ft	HEEL deg.	UPRIGHT GMT ft
INTACT	754	8.750	7.710	1.040A	0.0	7.602
DAMAGED	881	10.301	7.616	2.685A	0.1P	6.445

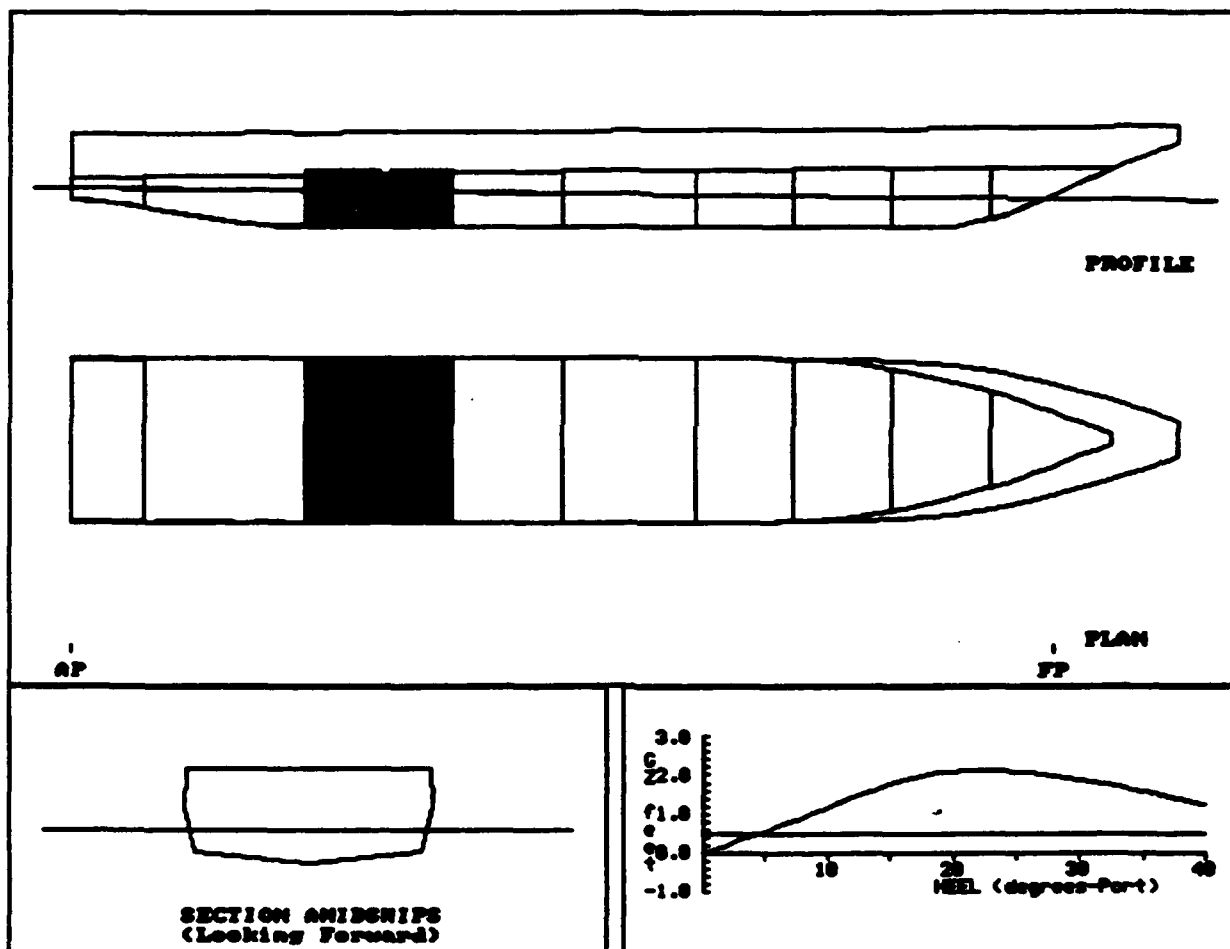

RTRN010B: LAVS/H2O
 200' DINNER BOAT

COMPARTMENT FLOODING SUMMARY

At 0.10P Heel	PERM.	FLOODED WTR LTons	% FULL (Damaged)	% FULL (Intact)	SP.VOL. ft ³ /LT	OUTFLOW LTons
LAVS	0.95	122	FREE	0.0	----	----
FRESH H2O P	0.95	7	FREE	10.0	35.0063	2
Totals		129				2

INTACT DATA

Draft at AP = 8.750 ft KMT = 28.742 ft LCG = 84.985A ft-FP
 Draft at FP = 7.710 ft VCG = 21.140 ft LCB = 85.086A ft-FP
 Displacement = 754 LTons GMT = 7.602 ft TCG = 0.000 ft-CL

DRAFT/GZ DATA

HEEL degrees	RIGHTING ARM ft	DRAFT AFT ft	DRAFT FWD ft	FLOODED WATER LTons
0.0	-0.017	10.300	7.616	129
5.0P	0.551	10.324	7.592	131
7.0P	0.788	10.326	7.572	132
10.0P	1.150	10.306	7.538	134
15.0P	1.760	10.143	7.500	133
20.0P	2.091	9.746	7.336	124
22.0P	2.119	9.509	7.237	120
27.0P	2.028	8.780	6.876	110
30.0P	1.894	8.228	6.590	104
35.0P	1.579	7.102	5.998	95
40.0P	1.207	5.695	5.198	85

Note: Drafts are measured at A.P. and F.P along ship's centerline

GZ SUMMARY (Evaluated per IMO (SOLAS'90) Rules for Passenger Ships)

	Available	Required
Static Heel Angle	0.1P deg	7.0 deg
Angle at Maximum GZ	23.0P deg	
Maximum GZ	2.119 ft	0.500 ft
Range of Positive GZ	39.9 deg	15.0 deg
Righting Area (0.1-22.0)	26.89 ft-deg	2.82 ft-deg

RTRN011B: LAVS/FUEL/H2O
 200' DINNER BOAT

Damaged Compartments:

LAVS FRESH H2O P FUEL PORT

	DISPLACEMENT LTons	DRAFT AFT ft	DRAFT FWD ft	TRIM ft	HEEL deg.	UPRIGHT GMT ft
INTACT	754	8.750	7.710	1.040A	0.0	7.602
DAMAGED	893	10.460	7.584	2.876A	1.9P	5.723

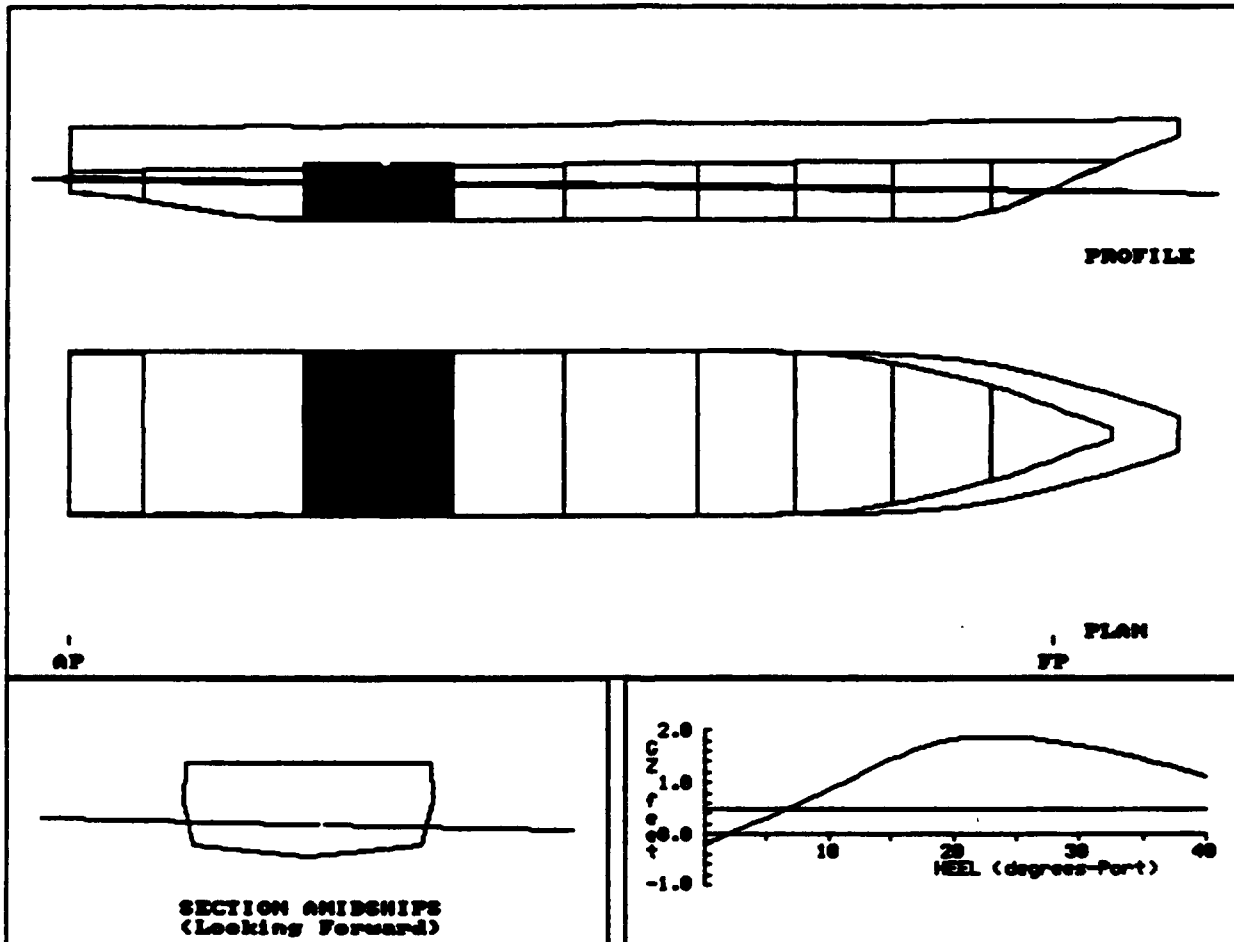

RTRN011B: LAVS/FUEL/H2O
 200' DINNER BOAT

COMPARTMENT FLOODING SUMMARY

At 1.90P Heel	PERM.	FLOODED WTR LTons	% FULL (Damaged)	% FULL (Intact)	SP.VOL. ft3/LT	OUTFLOW LTons
LAVS	0.95	124	FREE	0.0	----	----
FRESH H2O P	0.95	8	FREE	10.0	35.0063	2
FUEL PORT	0.95	11	FREE	10.0	39.0000	2
Totals		143				4

INTACT DATA

Draft at AP = 8.750 ft	Kmt = 28.742 ft	LCG = 84.985A ft-FP
Draft at FP = 7.710 ft	VCG = 21.140 ft	LCB = 85.086A ft-FP
Displacement = 754 LTons	GMT = 7.602 ft	TCG = 0.000 ft-CL

DRAFT/GZ DATA

HEEL degrees	RIGHTING ARM ft	DRAFT AFT ft	DRAFT FWD ft	FLOODED WATER LTons
0.0	-0.195	10.433	7.593	140
5.0P	0.312	10.503	7.564	147
7.0P	0.525	10.528	7.538	149
10.0P	0.856	10.544	7.498	153
15.0P	1.440	10.457	7.432	156
20.0P	1.825	10.123	7.253	149
22.0P	1.873	9.903	7.149	145
27.0P	1.834	9.210	6.778	135
30.0P	1.726	8.680	6.487	129
35.0P	1.458	7.590	5.885	119
40.0P	1.129	6.223	5.077	109

Note: Drafts are measured at A.P. and F.P along ship's centerline

GZ SUMMARY (Evaluated per IMO (SOLAS'90) Rules for Passenger Ships)

	Available	Required
Static Heel Angle	1.9P deg	7.0 deg
Angle at Maximum GZ	24.0P deg	
Maximum GZ	1.881 ft	0.500 ft
Range of Positive GZ	38.1 deg	15.0 deg
Righting Area (1.9-22.0)	21.14 ft-deg	2.82 ft-deg

RTRN012B: LAVS/SEW TANK
 200' DINNER BOAT

Imaged Compartments:
 LAVS SEW TANK

	DISPLACEMENT LTons	DRAFT AFT ft	DRAFT FWD ft	TRIM ft	HEEL deg.	UPRIGHT GMT ft
INTACT	754	8.750	7.710	1.040A	0.0	7.602
DAMAGED	875	10.234	7.603	2.632A	0.8S	7.158

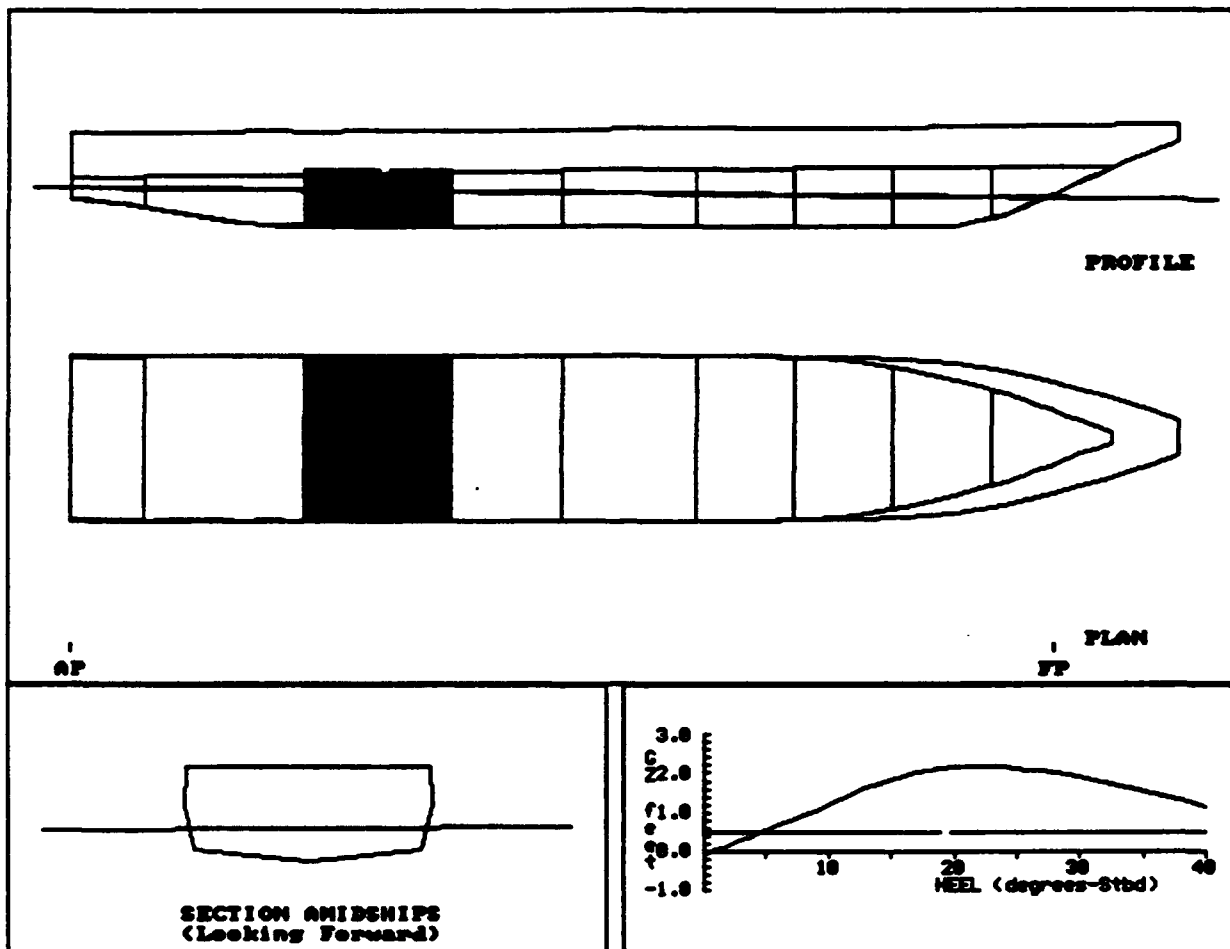

RTRN012B: LAVS/SEW TMR
 200' DINNER BOAT

COMPARTMENT FLOODING SUMMARY

At 0.8oS Heel	PERM.	FLOODED WTR LTons	% FULL (Damaged)	% FULL (Intact)	SP.VOL. ft ³ /LT	OUTFLOW LTons
LAVS	0.95	121	FREE	0.0	----	----
SEW TANK	0.95	17	FREE	100.0	35.0063	17
Totals		138				17

INTACT DATA

Draft at AP = 8.750 ft	KMt = 28.742 ft	LCG = 84.985A ft-FP
Draft at FP = 7.710 ft	VCG = 21.140 ft	LCB = 85.086A ft-FP
Displacement = 754 LTons	GMT = 7.602 ft	TCG = 0.000 ft-CL

DRAFT/GZ DATA

HEEL degrees	RIGHTING ARM ft	DRAFT AFT ft	DRAFT FWD ft	FLOODED WATER LTons
0.0	-0.102	10.233	7.608	138
5.0S	0.530	10.233	7.573	138
7.0S	0.792	10.218	7.556	138
10.0S	1.190	10.176	7.521	137
15.0S	1.846	9.964	7.490	133
20.0S	2.165	9.517	7.328	122
22.0S	2.182	9.267	7.231	118
27.0S	2.058	8.510	6.871	108
30.0S	1.901	7.943	6.587	102
35.0S	1.549	6.788	5.997	93
40.0S	1.140	5.351	5.201	83

Note: Drafts are measured at A.P. and F.P along ship's centerline

GZ SUMMARY (Evaluated per IMO (SOLAS'90) Rules for Passenger Ships)

	Available	Required
Static Heel Angle	0.8S deg	7.0 deg
Angle at Maximum GZ	23.0S deg	
Maximum GZ	2.182 ft	0.500 ft
Range of Positive GZ	39.2 deg	15.0 deg
Righting Area (0.8-22.0)	27.59 ft-deg	2.82 ft-deg

RTRN013B: LAVS/SEW/H2O
 200' DINNER BOAT

Damaged Compartments:

LAVS SEW TANK FRESH H2O P

	DISPLACEMENT LTons	DRAFT AFT ft	DRAFT FWD ft	TRIM ft	HEEL deg.	UPRIGHT GMT ft
INTACT	754	8.750	7.710	1.040A	0.0	7.602
DAMAGED	881	10.301	7.616	2.685A	0.1P	6.596

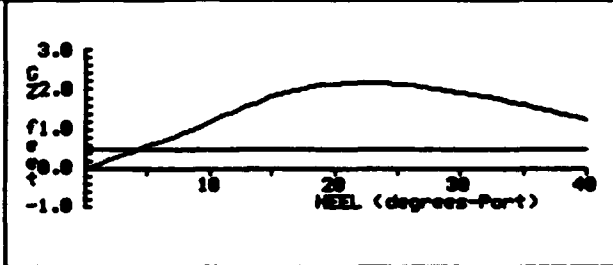
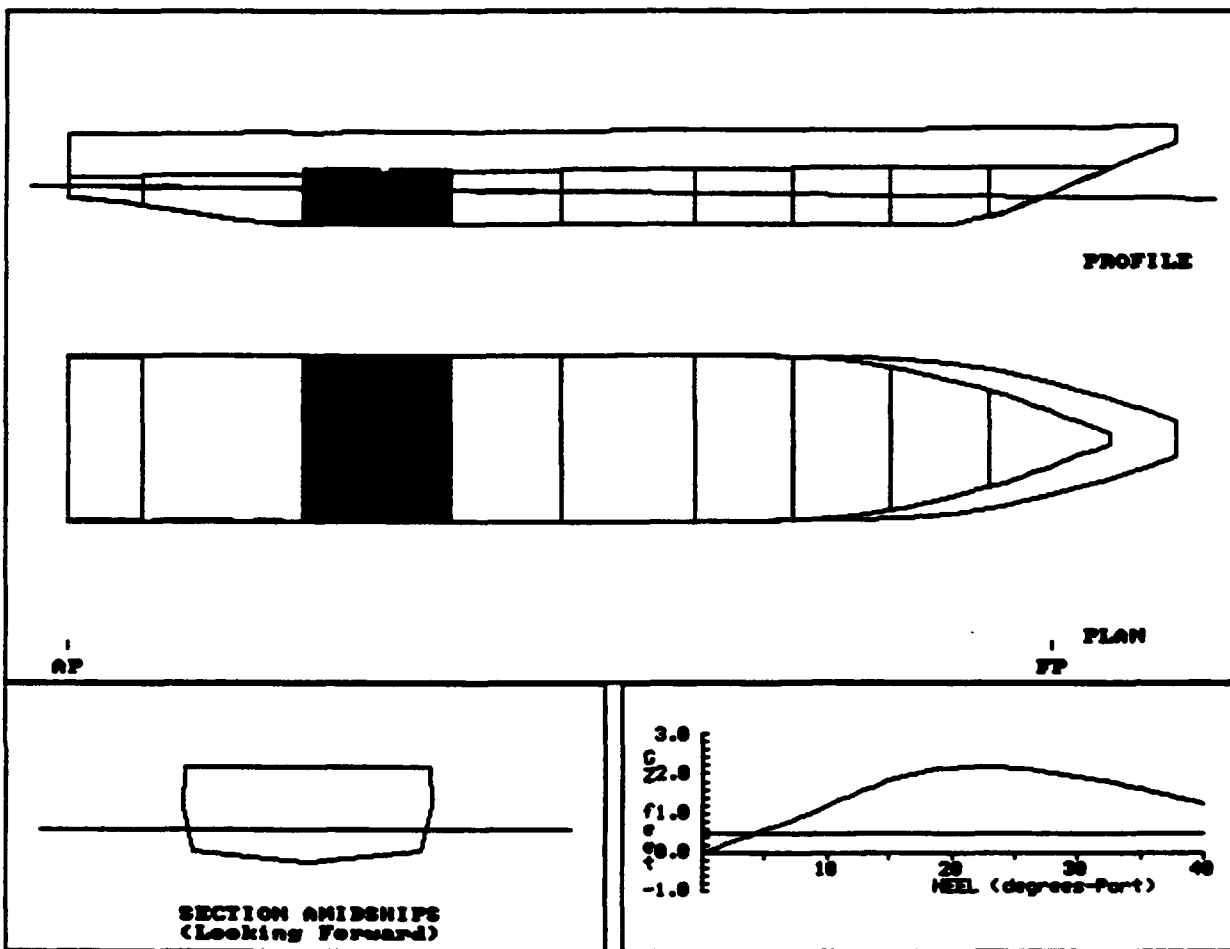

RTRN013B: LAVS/SEW/H2O
 200' DINNER BOAT

COMPARTMENT FLOODING SUMMARY

At 0.10P Heel	PERM.	FLOODED WTR LTons	% FULL (Damaged)	% FULL (Intact)	SP.VOL. ft ³ /LT	OUTFLOW LTons
LAVS	0.95	122	FREE	0.0	----	----
SEW TANK	0.95	17	FREE	100.0	35.0063	17
FRESH H2O P	0.95	7	FREE	10.0	35.0063	2
Totals		146				19

INTACT DATA

Draft at AP = 8.750 ft	KMT = 28.742 ft	LCG = 84.985A ft-FP
Draft at FP = 7.710 ft	VCG = 21.140 ft	LCB = 85.086A ft-FP
Displacement = 754 LTons	GMT = 7.602 ft	TCG = 0.000 ft-CL

DRAFT/GZ DATA

HEEL degrees	RIGHTING ARM ft	DRAFT AFT ft	DRAFT FWD ft	FLOODED WATER LTons
0.0	-0.017	10.300	7.616	146
5.0P	0.564	10.324	7.592	149
7.0P	0.806	10.326	7.572	150
10.0P	1.177	10.306	7.538	151
15.0P	1.801	10.143	7.500	150
20.0P	2.141	9.746	7.336	142
22.0P	2.168	9.509	7.237	137
27.0P	2.076	8.780	6.876	127
30.0P	1.939	8.228	6.590	122
35.0P	1.616	7.102	5.998	112
40.0P	1.235	5.695	5.198	103

Note: Drafts are measured at A.P. and F.P along ship's centerline

GZ SUMMARY (Evaluated per IMO (SOLAS'90) Rules for Passenger Ships)

	Available	Required
Static Heel Angle	0.1P deg	7.0 deg
Angle at Maximum GZ	23.0P deg	
Maximum GZ	2.168 ft	0.500 ft
Range of Positive GZ	39.9 deg	15.0 deg
Righting Area (0.1-22.0)	27.52 ft-deg	2.82 ft-deg

RTRN014B: LAVS/SEW/FUEL
 200' DINNER BOAT

Managed Compartments:

LAVS SEW TANK FUEL PORT

	DISPLACEMENT LTons	DRAFT AFT ft	DRAFT FWD ft	TRIM ft	HEEL deg.	UPRIGHT Gmt ft
INTACT	754	8.750	7.710	1.040A	0.0	7.602
DAMAGED	885	10.369	7.580	2.789A	0.7P	6.466

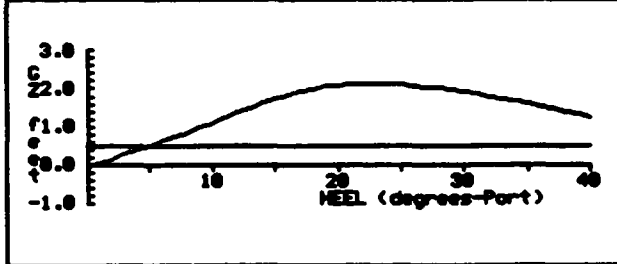
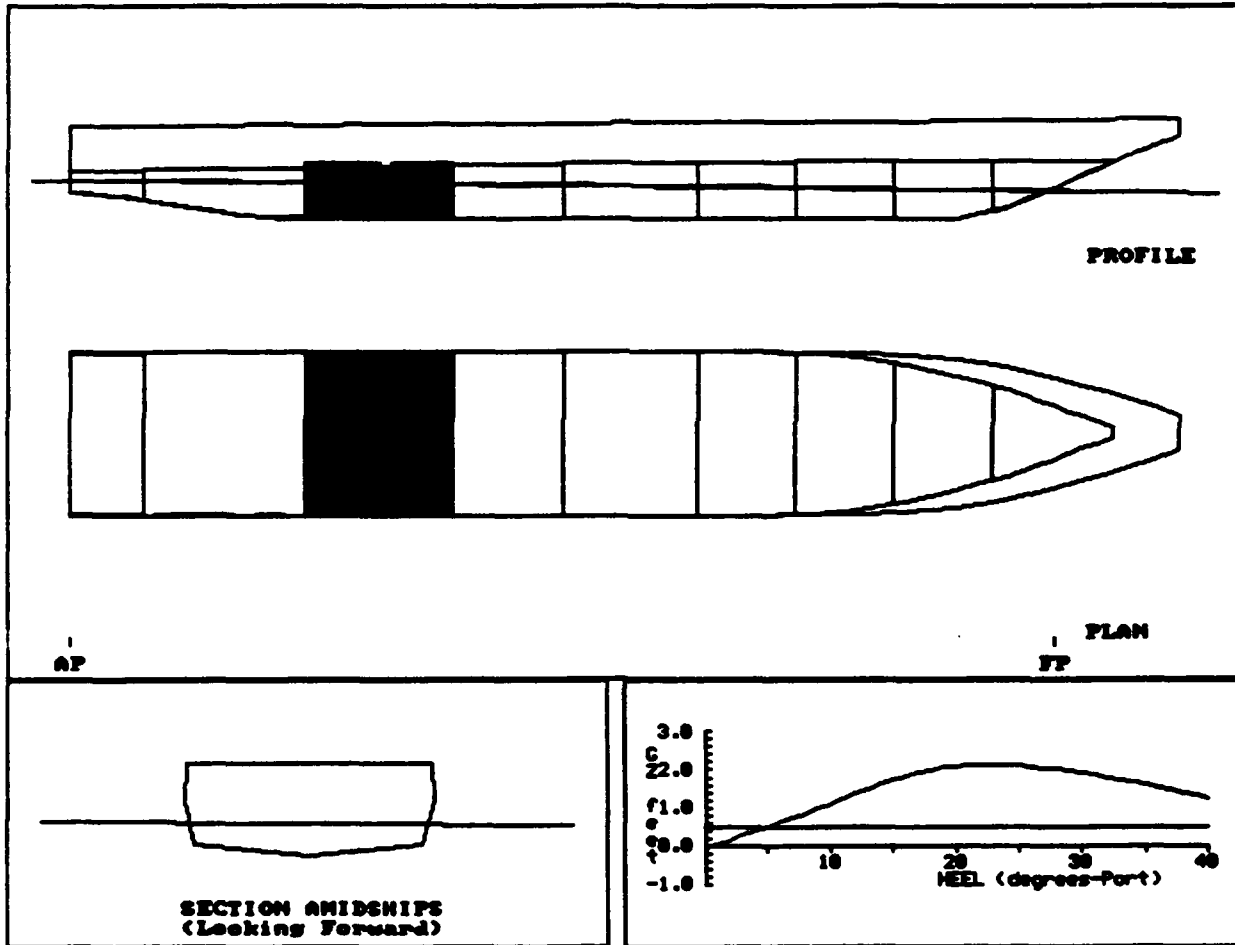

**RTM014B: LAVS/SEW/FUEL
 200' DINNER BOAT**

COMPARTMENT FLOODING SUMMARY

At 0.7oP Heel	PERM.	FLOODED WTR LTons	% FULL (Damaged)	% FULL (Intact)	SP.VOL. ft3/LT	OUTFLOW LTons
LAVS	0.95	122	FREE	0.0	----	----
SEW TANK	0.95	17	FREE	100.0	35.0063	17
FUEL PORT	0.95	10	FREE	10.0	39.0000	2
Totals		150				19

INTACT DATA

Draft at AP = 8.750 ft	KMt = 28.742 ft	LCG = 84.985A ft-FP
Draft at FP = 7.710 ft	VCG = 21.140 ft	LCB = 85.086A ft-FP
Displacement = 754 LTons	GMT = 7.602 ft	TCG = 0.000 ft-CL

DRAFT/GZ DATA

HEEL degrees	RIGHTING ARM ft	DRAFT AFT ft	DRAFT FWD ft	FLOODED WATER LTons
0.0	-0.074	10.363	7.585	150
5.0P	0.497	10.406	7.547	153
7.0P	0.736	10.414	7.522	154
10.0P	1.103	10.409	7.480	156
15.0P	1.731	10.273	7.421	156
20.0P	2.091	9.897	7.243	147
22.0P	2.125	9.665	7.140	143
27.0P	2.046	8.950	6.771	133
30.0P	1.913	8.407	6.480	127
35.0P	1.603	7.294	5.881	117
40.0P	1.232	5.902	5.074	108

Note: Drafts are measured at A.P. and F.P along ship's centerline

GZ SUMMARY (Evaluated per IMO (SOLAS'90) Rules for Passenger Ships)

	Available	Required
Static Heel Angle	0.7P deg	7.0 deg
Angle at Maximum GZ	24.0P deg	
Maximum GZ	2.126 ft	0.500 ft
Range of Positive GZ	39.3 deg	15.0 deg
Righting Area (0.7-22.0)	26.12 ft-deg	2.82 ft-deg

RTRN015B: LAVS/SEW/FUEL/H2O
 200' DINNER BOAT

Imaged Compartments:

LAVS SEW TANK FRESH H2O P FUEL PORT

	DISPLACEMENT LTons	DRAFT AFT ft	DRAFT FWD ft	TRIM ft	HEEL deg.	UPRIGHT GMT ft
INTACT	754	8.750	7.710	1.040A	0.0	7.602
DAMAGED	893	10.460	7.584	2.876A	1.9P	5.858

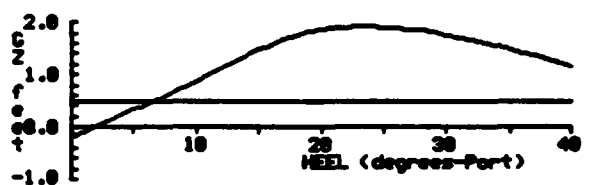
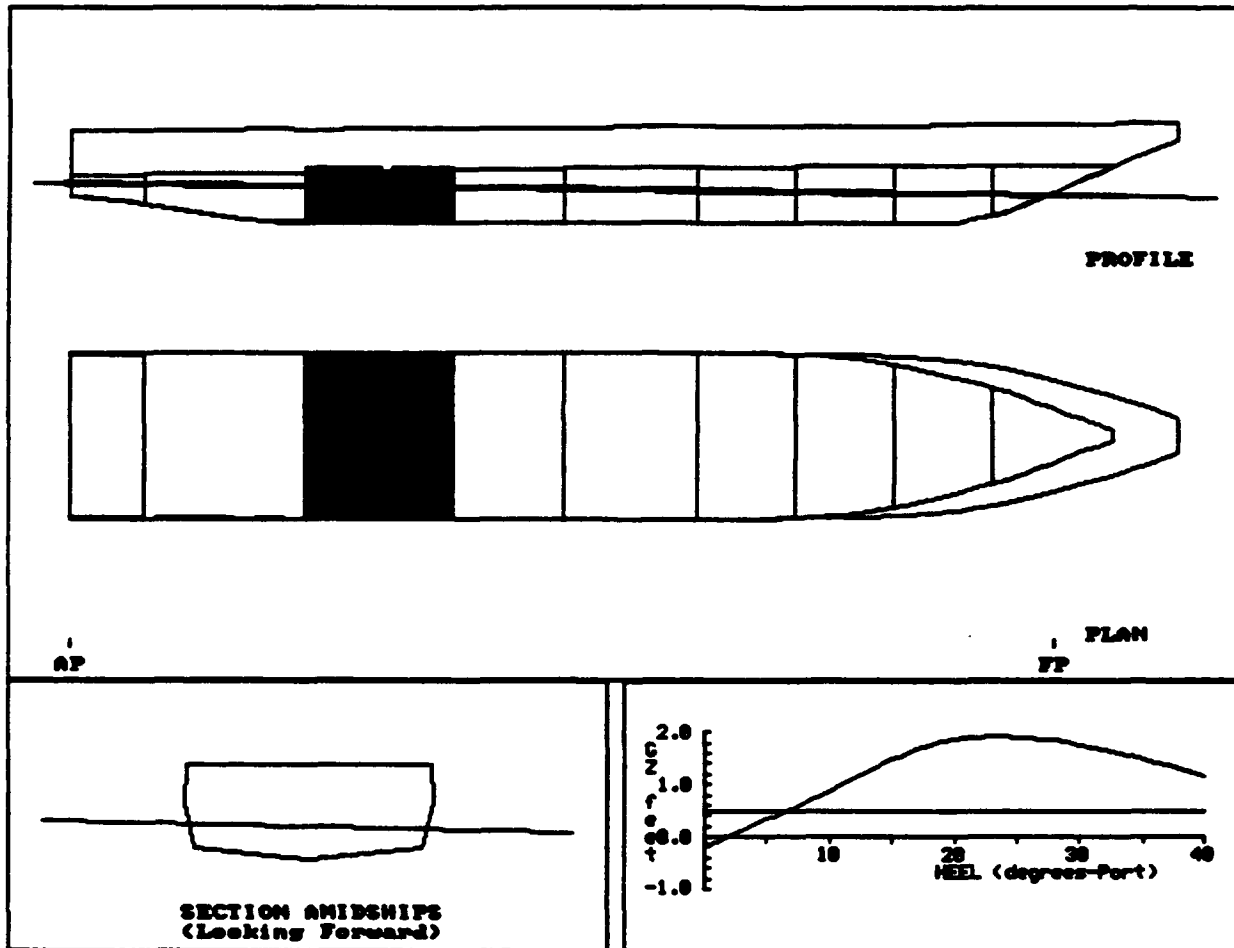

RTRN015B: LAVS/SEW/FUEL/H2O
 200' DINNER BOAT

COMPARTMENT FLOODING SUMMARY

At 1.9oP Heel	PERM.	FLOODED WTR LTons	% FULL (Damaged)	% FULL (Intact)	SP.VOL. ft3/LT	OUTFLOW LTons
LAVS	0.95	124	FREE	0.0	----	----
SEW TANK	0.95	17	FREE	100.0	35.0063	17
FRESH H2O P	0.95	8	FREE	10.0	35.0063	2
FUEL PORT	0.95	11	FREE	10.0	39.0000	2
Totals		160				21

INTACT DATA

Draft at AP = 8.750 ft	KMt = 28.742 ft	LCG = 84.985A ft-FP
Draft at FP = 7.710 ft	VCG = 21.140 ft	LCB = 85.086A ft-FP
Displacement = 754 LTons	GMT = 7.602 ft	TCG = 0.000 ft-CL

DRAFT/GZ DATA

HEEL degrees	RIGHTING ARM ft	DRAFT AFT ft	DRAFT FWD ft	FLOODED WATER LTons
0.0	-0.200	10.433	7.593	158
5.0P	0.320	10.503	7.564	164
7.0P	0.537	10.528	7.538	167
10.0P	0.876	10.544	7.498	170
15.0P	1.474	10.457	7.432	173
20.0P	1.868	10.123	7.253	166
22.0P	1.917	9.903	7.149	162
27.0P	1.877	9.210	6.778	152
30.0P	1.767	8.680	6.487	146
35.0P	1.492	7.590	5.885	136
40.0P	1.156	6.223	5.077	127

Note: Drafts are measured at A.P. and F.P along ship's centerline

GZ SUMMARY (Evaluated per IMO (SOLAS'90) Rules for Passenger Ships)

	Available	Required
Static Heel Angle	1.9P deg	7.0 deg
Angle at Maximum GZ	24.0P deg	
Maximum GZ	1.926 ft	0.500 ft
Range of Positive GZ	38.1 deg	15.0 deg
Righting Area (1.9-22.0)	21.64 ft-deg	2.82 ft-deg

**APPENDIX B
HYDROSTATICS AND
DAMAGE STABILITY
OUTPUT**

192' EXCURSION BOAT

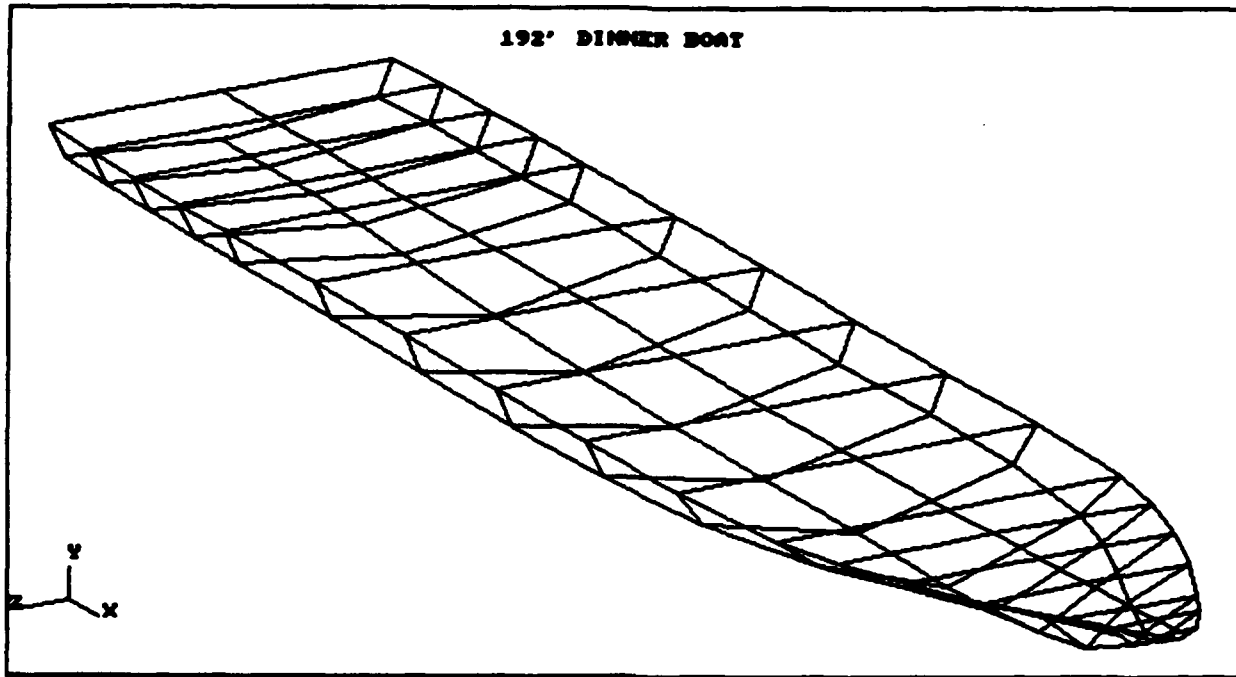

DAMAGE STABILITY SUMMARY
192' DINNER BOAT

C No.	FILE NAME	DAMAGED COMP. LISTING	---Intact Condition---			-----Equilibrium Condition After Damage-----					SURVIVAL
			MIN.DRAFT (ft)	VCG (ft)	GMT (ft)	HEEL (deg)	MAX.GZ (ft)	RANGE (deg)	AREA (ft-deg)	DAM.GMT (ft)	
1	DPRT001A	1	6.915	16.010	12.579	0.0	2.455	37.71	38.29	12.529	Yes
2	DPRT002A	1,2	6.915	16.010	12.579	0.0	2.383	35.70	37.36	12.668	Yes
3	DPRT003A	2	6.915	16.010	12.579	0.0	2.404	36.47	37.59	12.569	Yes
4	DPRT004A	3	6.915	16.010	12.579	0.0	2.091	34.20	32.99	11.359	Yes
5	DPRT005A	4	6.915	16.010	12.579	0.0	1.757	30.44	27.22	9.381	Yes
6	DPRT006A	5	6.915	16.010	12.579	0.0	2.298	35.61	35.56	11.268	Yes
7	DPRT007A	5,7	6.915	16.010	12.579	0.5P	2.136	34.25	32.39	----	Yes
8	DPRT008A	10	6.915	16.010	12.579	0.0	1.813	31.38	27.88	9.028	Yes
9	DPRT009A	11	6.915	16.010	12.579	0.0	2.084	34.34	32.12	10.079	Yes
10	DPRT010A	12	6.915	16.010	12.579	0.0	2.084	34.40	32.17	10.138	Yes

HYDROSTATIC TABLES
 192' DINNER BOAT

MOLDED DRAFT (ft)		2.000	3.000	4.000	5.000	5.500	6.180	6.860	7.530	8.210	8.890
DISP.MLD. (LTons-SW)		20.3	56.3	114.9	203.8	259.3	339.8	422.6	506.2	592.8	681.4
DISP.TOTAL (LTons-SW)		20.4	56.6	115.5	204.8	260.6	341.5	424.8	508.7	595.8	684.8
DISP.TOTAL (LTons-FW)		19.9	55.2	112.6	199.8	254.2	333.1	414.4	496.3	581.2	668.1
LCB (ft-FP)		68.075A	70.808A	74.085A	78.611A	80.627A	82.364A	83.248A	83.723A	83.977A	84.073A
LCB (forebody) (ft-FP)		51.541A	51.043A	50.745A	50.450A	50.273A	49.919A	49.511A	49.121A	48.738A	48.351A
LCB (aftbody) (ft-FP)		92.731A	95.807A	99.480A	104.532A	106.707A	108.762A	109.991A	110.799A	111.386A	111.825A
TCB (ft-CL)		0.000	0.000	0.000	0.000	0.000	0.000	0.000	0.000	0.000	0.000
KB (ft)		1.467	2.155	2.858	3.584	3.940	4.389	4.805	5.198	5.587	5.971
BMT (ft)		10.190	16.725	23.861	33.322	34.007	28.058	23.690	20.707	18.491	16.839
KMT (ft)		11.656	18.880	26.719	36.906	37.947	32.447	28.495	25.905	24.079	22.811
BML (ft)		865.577	692.357	707.921	693.913	646.456	527.000	444.983	387.720	344.274	313.774
KML (ft)		867.044	694.512	710.778	697.497	650.396	531.389	449.788	392.918	349.861	319.746
	(LTons)	2.17	3.87	6.07	8.75	9.66	10.02	10.27	10.50	10.73	10.98
	(ft-LTons)	9.5	21.2	44.2	76.8	91.1	97.3	102.2	106.7	110.9	116.2
	(LTons)	-0.09	-0.06	0.16	0.59	0.76	0.70	0.66	0.63	0.59	0.55
LCF (ft-FP)		70.243A	74.257A	80.681A	87.051A	88.754A	87.415A	86.537A	85.797A	85.135A	84.308A
W.P. AREA (ft2)		910.9	1,624.1	2,549.7	3,673.8	4,057.6	4,208.8	4,314.8	4,412.0	4,505.8	4,610.9
WETTED SUR. (ft2)		969.0	1,727.2	2,707.0	3,897.5	4,355.2	4,654.9	4,920.3	5,176.8	5,434.4	5,701.5
MAX. BEAM (ft)		11.429	18.273	25.116	31.960	32.258	32.613	32.969	33.318	33.674	34.029
LENGTH W.L. (ft)		110.760	125.792	148.219	149.923	150.775	151.933	153.092	154.225	155.373	156.522
Cb		0.0661	0.1224	0.1874	0.2658	0.3075	0.3586	0.4019	0.4385	0.4710	0.4999
Cb (forebody)		0.0792	0.1367	0.1953	0.2548	0.2842	0.3218	0.3554	0.3850	0.4121	0.4372
Cb (aftbody)		0.0531	0.1081	0.1795	0.2768	0.3308	0.3955	0.4484	0.4920	0.5299	0.5627
Cm		0.1363	0.2323	0.3292	0.4264	0.4710	0.5211	0.5622	0.5964	0.6262	0.6523
Cp		0.4852	0.5269	0.5691	0.6234	0.6529	0.6882	0.7148	0.7353	0.7521	0.7665
Cwp		0.1697	0.3026	0.4751	0.6846	0.7561	0.7843	0.8040	0.8221	0.8396	0.8592
Cit		0.0132	0.0602	0.1752	0.4338	0.5634	0.6092	0.6398	0.6698	0.7005	0.7331

Assumes: Sea Water at 35.0063 ft3/LT
 Fresh Water at 35.8814 ft3/LT
 Ship floating at even keel (no heel or trim)

HYDROSTATIC TABLES (cont.)
 192' DINNER BOAT

HOLDED DRAFT (ft)		9.570	10.250

DISP.MLD.	(LTons-SW)	772.0	864.8
DISP.TOTAL	(LTons-SW)	775.9	869.2
DISP.TOTAL	(LTons-FW)	757.0	848.0
LCB	(ft-FP)	84.043A	83.930A
LCB (forebody)	(ft-FP)	47.940A	47.519A
LCB (aftbody)	(ft-FP)	112.166A	112.439A
TCB	(ft-CL)	0.000	0.000
KB	(ft)	6.353	6.734
BMT	(ft)	15.568	14.568
KM	(ft)	21.921	21.302
BMI	(ft)	291.079	273.055
KMI	(ft)	297.432	279.789
	(LTons)	11.24	11.52
	(ft-LTons)	122.1	128.3
	(LTons)	0.49	0.44
LCF	(ft-FP)	83.391A	82.457A
M.P. AREA	(ft ²)	4,723.4	4,839.2
WETTED SUR.	(ft ²)	5,975.3	6,252.7
MAX. BEAM	(ft)	34.384	34.739
LENGTH W.L.	(ft)	157.657	158.776
Cb		0.5262	0.5504
Cb (forebody)		0.4608	0.4834
Cb (aftbody)		0.5916	0.6174
Cm		0.6753	0.6960
Cp		0.7792	0.7907
Cmp		0.8802	0.9017
Cit		0.7680	0.8051

**DAMAGE STABILITY SUMMARY
 192' DINNER BOAT**

Ca	No.	FILE NAME	DAMAGED COMP. LISTING	---Intact Condition---			-----Equilibrium Condition After Damage-----					
				MM.DRAFT (ft)	VCG (ft)	GMT (ft)	HEEL (deg)	MAX.GZ (ft)	RANGE (deg)	AREA (ft-deg)	DAM.GMT (ft)	SURVIVAL
	1	RTRN001A	1	6.860	15.990	12.914	0.0	2.486	38.20	38.85	12.863	Yes
	2	RTRN002A	1,2	6.860	15.990	12.914	0.0	2.414	36.14	37.92	13.005	Yes
	3	RTRN003A	2	6.860	15.990	12.914	0.0	2.434	36.93	38.15	12.904	Yes
	4	RTRN004A	3	6.860	15.990	12.914	0.0	2.123	34.69	33.57	11.668	Yes
	5	RTRN005A	4	6.860	15.990	12.914	0.0	1.804	31.03	28.07	9.630	Yes
	6	RTRN006A	5	6.860	15.990	12.914	0.0	2.343	36.17	36.32	11.569	Yes
	7	RTRN007A	5,7	6.860	15.990	12.914	0.3s	2.201	35.01	33.76	----	Yes
	8	RTRN008A	10	6.860	15.990	12.914	0.0	1.885	32.13	29.04	9.278	Yes
	9	RTRN009A	11	6.860	15.990	12.914	0.0	2.143	34.98	33.02	10.359	Yes
	10	RTRN010A	12	6.860	15.990	12.914	0.0	2.146	35.06	33.10	10.424	Yes

DPR001A:
 192' DINNER BOAT

Imaged Compartments:
 FOREPEAK

	DISPLACEMENT LTONS	DRAFT AFT ft	DRAFT FWD ft	TRIM ft	HEEL deg.	UPRIGHT GMT ft
INTACT	425.5	6.520	7.310	0.790F	0.00	12.579
DAMAGED	429.0	6.448	7.466	1.018F	0.00	12.529

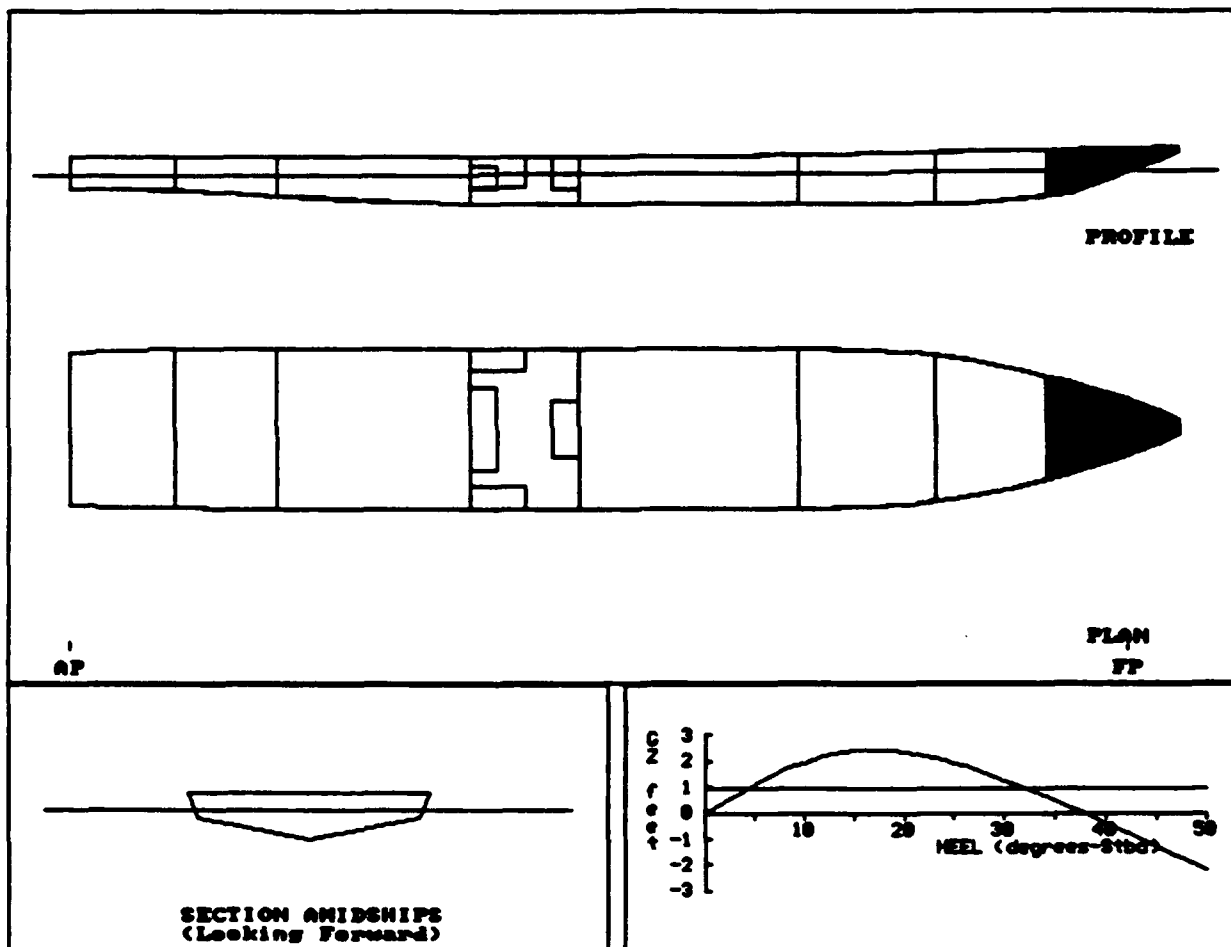

DPR001A:
 192' DINNER BOAT

COMPARTMENT FLOODING SUMMARY

At 0.0o Heel	PERM.	FLOODED WTR LTons	% FULL (Damaged)	% FULL (Intact)	SP.VOL. ft3/LT	OUTFLOW LTons
FOREPEAK	0.95	3.5	FREE	0.0	----	----
Totals		3.5				

INTACT DATA

Draft at AP = 6.520 ft	KMt = 28.589 ft	LCG = 80.996A ft-FP
Draft at FP = 7.310 ft	VCG = 16.010 ft	LCB = 80.938A ft-FP
Displacement = 425.5 LTons	GMT = 12.579 ft	TCG = 0.000 ft-CL

DRAFT/GZ DATA

HEEL degrees	RIGHTING ARM ft	DRAFT AFT ft	DRAFT FWD ft	FLOODED WATER LTons
0.00	0.000	6.448	7.466	3.5
5.00S	1.091	6.440	7.422	3.5
7.00S	1.482	6.400	7.395	3.4
10.00S	1.939	6.282	7.320	3.3
15.00S	2.413	5.894	7.162	3.2
20.00S	2.363	5.485	6.977	3.0
30.00S	1.244	4.750	6.684	3.3
40.00S	-0.398	3.956	6.474	4.3
50.00S	-2.217	2.935	6.330	5.6

Note: Drafts are measured at A.P. and F.P along ship's centerline

GZ SUMMARY (Evaluated per IMO (SOLAS'90) Rules for Passenger Ships)

	Available	Required
Static Heel Angle	0.00 deg	7.00 deg
Angle at Maximum GZ	18.00S deg	
Maximum GZ	2.455 ft	0.970 ft
Range of Positive GZ	37.71 deg	15.00 deg
Gmt (upright damaged)	12.529 ft	
Righting Area (0.00-%.00)	38.286 ft-deg	2.820 ft-deg

DPRT002A:
 192' DINNER BOAT

Imaged Compartments:
 FOREPEAK BOW THRUSTER

	DISPLACEMENT LTons	DRAFT AFT ft	DRAFT FWD ft	TRIM ft	HEEL deg.	UPRIGHT GNT ft
INTACT	425.5	6.520	7.310	0.790F	0.00	12.579
DAMAGED	462.7	5.941	8.700	2.758F	0.00	12.668

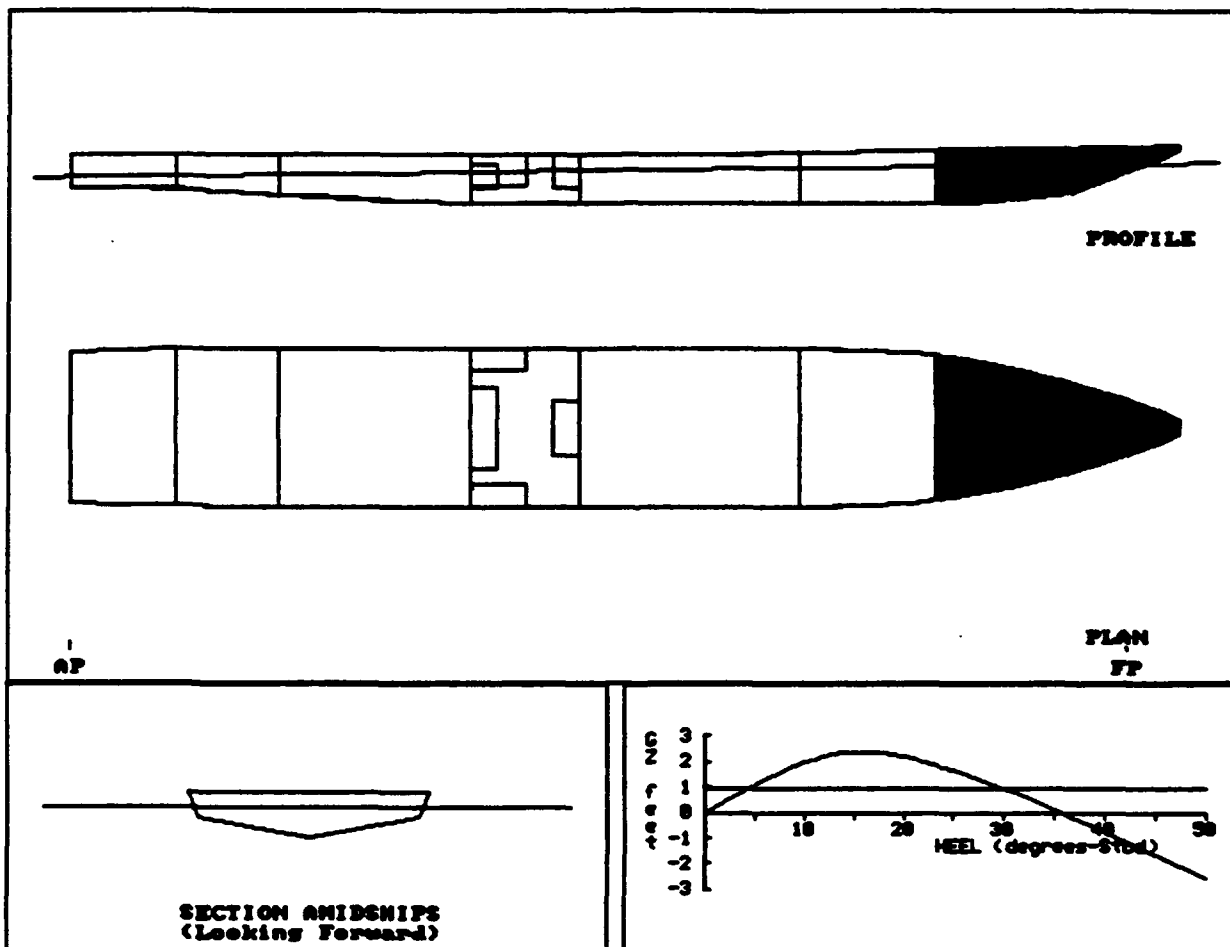

DPR002A:
 192' DINNER BOAT

COMPARTMENT FLOODING SUMMARY

At 0.0o Heel	PERM.	FLOODED WTR LTons	% FULL (Damaged)	% FULL (Intact)	SP.VOL. ft ³ /LT	OUTFLOW LTons
FOREPEAK	0.95	5.7	FREE	0.0	----	----
BOW THUSTER	0.95	31.5	FREE	0.0	----	----
Totals		37.3				

INTACT DATA

Draft at AP = 6.520 ft	KMT = 28.589 ft	LCG = 80.996A ft-FP
Draft at FP = 7.310 ft	VCG = 16.010 ft	LCB = 80.938A ft-FP
Displacement = 425.5 LTons	Gmt = 12.579 ft	TCG = 0.000 ft-CL

DRAFT/GZ DATA

HEEL degrees	RIGHTING ARM ft	DRAFT AFT ft	DRAFT FWD ft	FLOODED WATER LTons
0.00	0.000	5.941	8.700	37.3
5.00S	1.081	5.902	8.688	37.5
7.00S	1.467	5.834	8.695	37.9
10.00S	1.953	5.667	8.696	38.6
15.00S	2.374	5.221	8.709	40.7
20.00S	2.200	4.635	8.956	44.9
30.00S	0.944	3.346	9.850	52.9
40.00S	-0.758	1.830	11.135	58.7
50.00S	-2.587	-0.201	13.030	62.9

Note: Drafts are measured at A.P. and F.P along ship's centerline

GZ SUMMARY (Evaluated per IMO (SOLAS'90) Rules for Passenger Ships)

	Available	Required
Static Heel Angle	0.00 deg	7.00 deg
Angle at Maximum GZ	17.00S deg	
Maximum GZ	2.383 ft	0.970 ft
Range of Positive GZ	35.70 deg	15.00 deg
Gmt (upright damaged)	12.668 ft	
Righting Area (0.00-%.00)	37.365 ft-deg	2.820 ft-deg

DPR003A:
 192' DINNER BOAT

Imaged Compartments:
 BOW TRUSTER

	DISPLACEMENT LTons	DRAFT AFT ft	DRAFT FWD ft	TRIM ft	HEEL deg.	UPRIGHT GMT ft
INTACT	425.5	6.520	7.310	0.790F	0.00	12.579
DAMAGED	455.0	6.078	8.395	2.317F	0.00	12.569

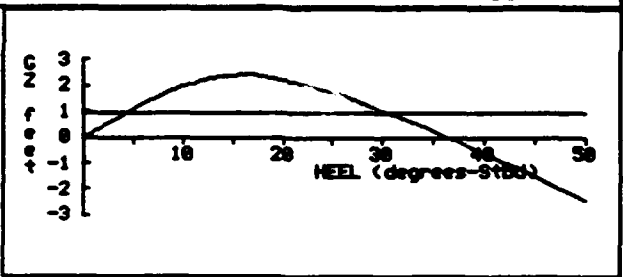
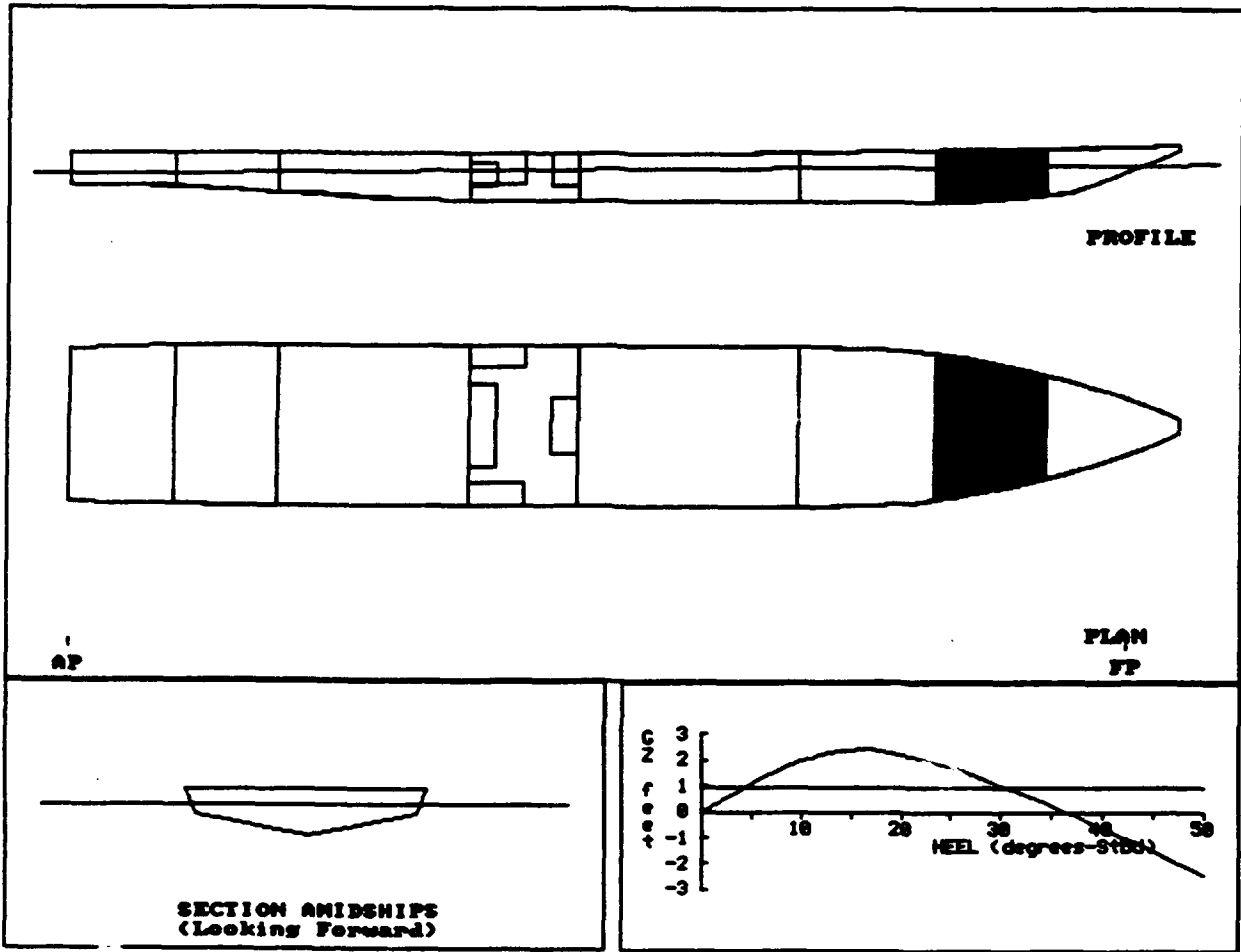

DPRT004A:
 192' DINNER BOAT

Imaged Compartments:
 TOILET SPACE

	DISPLACEMENT LTons	DRAFT AFT ft	DRAFT FWD ft	TRIM ft	HEEL deg.	UPRIGHT GMT ft
INTACT	425.5	6.520	7.310	0.790F	0.00	12.579
DAMAGED	503.6	5.859	9.498	3.639F	0.00	11.359

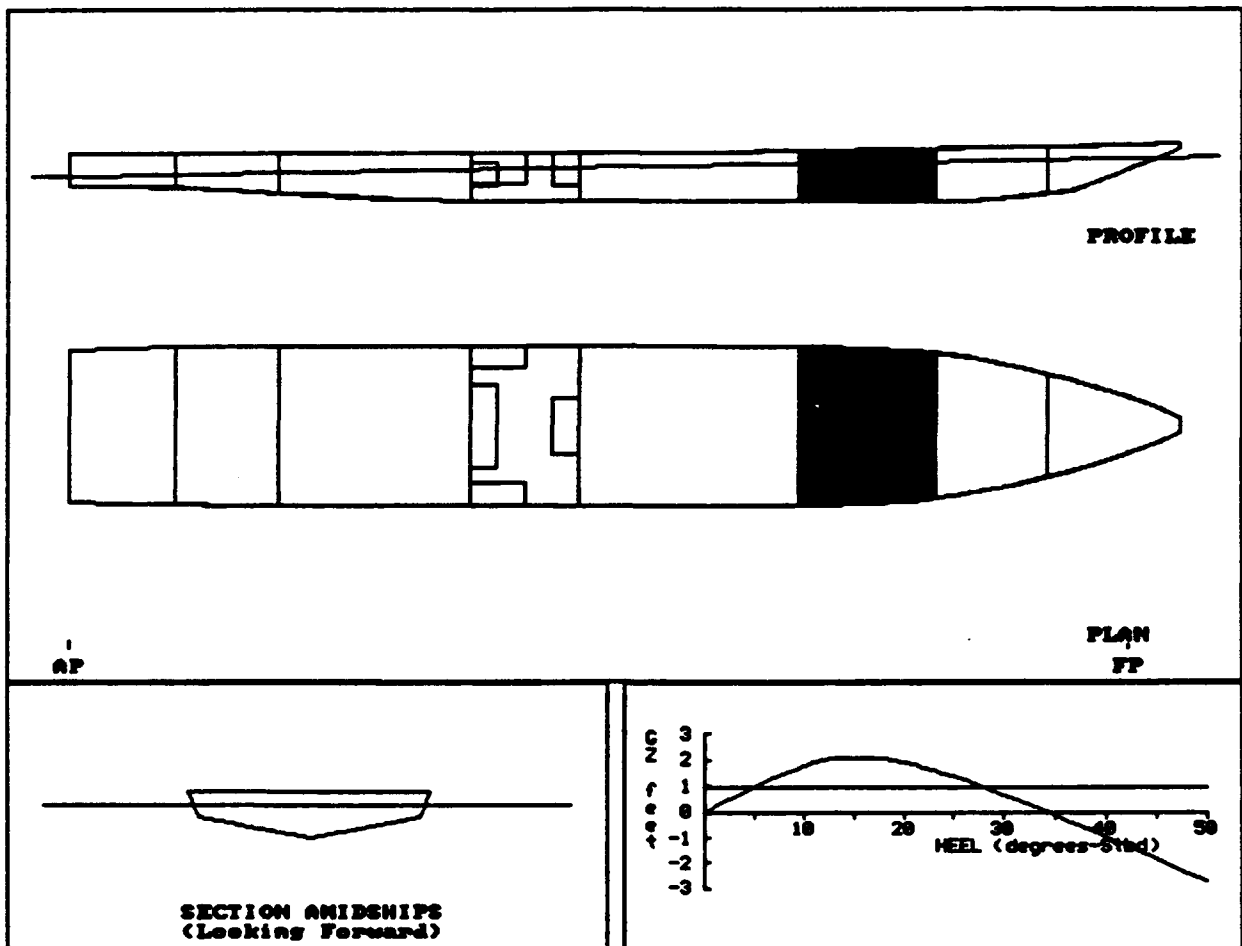

DPRT004A:
 192' DINNER BOAT

COMPARTMENT FLOODING SUMMARY

At 0.0o Heel	PERM.	FLOODED WTR LTons	% FULL (Damaged)	% FULL (Intact)	SP.VOL. ft3/LT	OUTFLOW LTons
TOILET SPACE	0.95	78.1	FREE	0.0	----	----
Totals		78.1				

INTACT DATA

Draft at AP = 6.520 ft	KMT = 28.589 ft	LCG = 80.996A ft-FP
Draft at FP = 7.310 ft	VCG = 16.010 ft	LCB = 80.938A ft-FP
Displacement = 425.5 LTons	GMT = 12.579 ft	TCG = 0.000 ft-CL

DRAFT/GZ DATA

HEEL degrees	RIGHTING ARM ft	DRAFT AFT ft	DRAFT FWD ft	FLOODED WATER LTons
0.00	0.000	5.859	9.498	78.1
5.00S	0.966	5.825	9.477	78.3
7.00S	1.312	5.764	9.475	78.7
10.00S	1.766	5.609	9.477	79.4
15.00S	2.091	5.205	9.540	79.6
20.00S	1.890	4.742	9.711	79.1
30.00S	0.663	3.807	10.271	78.3
40.00S	-0.975	2.783	11.066	77.6
50.00S	-2.730	1.464	12.245	77.0

Note: Drafts are measured at A.P. and F.P along ship's centerline

GZ SUMMARY (Evaluated per IMO (SOLAS '90) Rules for Passenger Ships)
 Available Required

Static Heel Angle	0.00 deg	7.00 deg
Angle at Maximum GZ	16.00S deg	
Maximum GZ	2.091 ft	0.970 ft
Range of Positive GZ	34.20 deg	15.00 deg
Gmt (upright damaged)	11.359 ft	
Righting Area (0.00-%.00)	32.988 ft-deg	2.820 ft-deg

DPRT005A:
 192' DINNER BOAT

Imaged Compartments:
 GALLEY

	DISPLACEMENT LTons	DRAFT AFT ft	DRAFT FWD ft	TRIM ft	HEEL deg.	UPRIGHT GMT ft
INTACT	425.5	6.520	7.310	0.790F	0.00	12.579
DAMAGED	586.1	6.607	9.986	3.379F	0.00	9.381

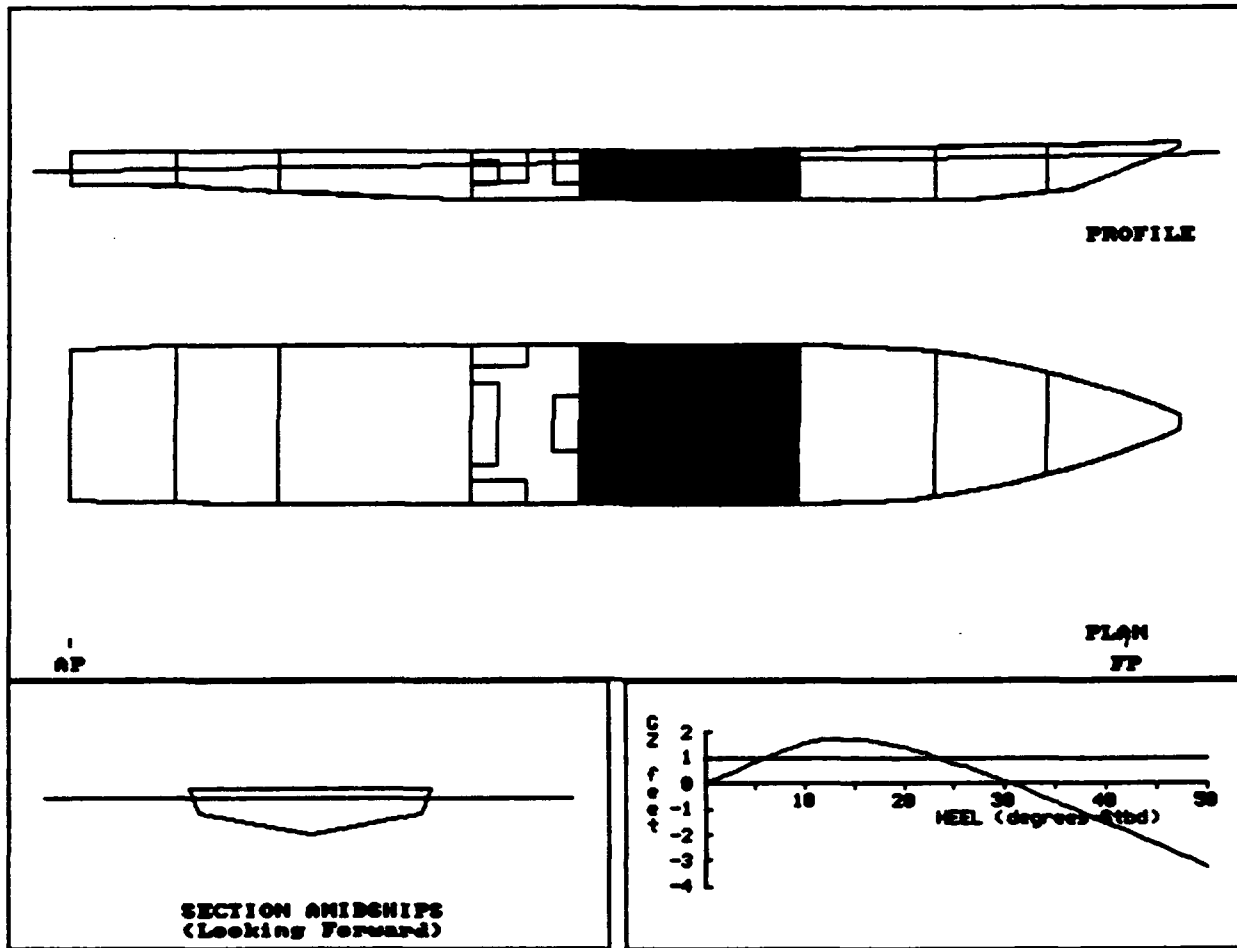

DPRT005A:
 192' DINNER BOAT

COMPARTMENT FLOODING SUMMARY

At 0.0o Heel	PERM.	FLOODED WTR LTons	% FULL (Damaged)	% FULL (Intact)	SP.VOL. ft3/LT	OUTFLOW LTons
GALLEY	0.95	160.6	FREE	0.0	----	----
Totals		160.6				

INTACT DATA

Draft at AP = 6.520 ft Kmt = 28.589 ft LCG = 80.996A ft-FP
 Draft at FP = 7.310 ft VCG = 16.010 ft LCB = 80.938A ft-FP
 Displacement = 425.5 LTons Gmt = 12.579 ft TCG = 0.000 ft-CL

DRAFT/GZ DATA

HEEL degrees	RIGHTING ARM ft	DRAFT AFT ft	DRAFT FWD ft	FLOODED WATER LTons
0.00	0.000	6.607	9.986	160.6
5.00S	0.825	6.606	9.929	160.2
7.00S	1.149	6.585	9.891	159.8
10.00S	1.560	6.501	9.848	158.2
15.00S	1.743	6.260	9.927	153.1
20.00S	1.393	6.056	10.108	149.3
30.00S	0.068	5.766	10.622	144.1
40.00S	-1.550	5.480	11.434	140.8
50.00S	-3.225	5.180	12.600	138.4

Note: Drafts are measured at A.P. and F.P along ship's centerline

GZ SUMMARY (Evaluated per IMO (SOLAS'90) Rules for Passenger Ships)
 Available Required

Static Heel Angle	0.00 deg	7.00 deg
Angle at Maximum GZ	15.00S deg	
Maximum GZ	1.757 ft	0.970 ft
Range of Positive GZ	30.44 deg	15.00 deg
Gmt (upright damaged)	9.381 ft	
Righting Area (0.00-7.00)	27.216 ft-deg	2.820 ft-deg

DFRT006A:
 192' DINNER BOAT

Damaged Compartments:
 TANKS

	DISPLACEMENT LTons	DRAFT AFT ft	DRAFT FWD ft	TRIM ft	HEEL deg.	UPRIGHT GMT ft
INTACT	425.5	6.520	7.310	0.790F	0.00	12.579
DAMAGED	474.3	6.924	7.680	0.756F	0.00	11.268

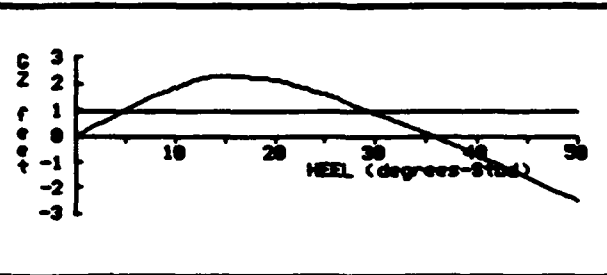
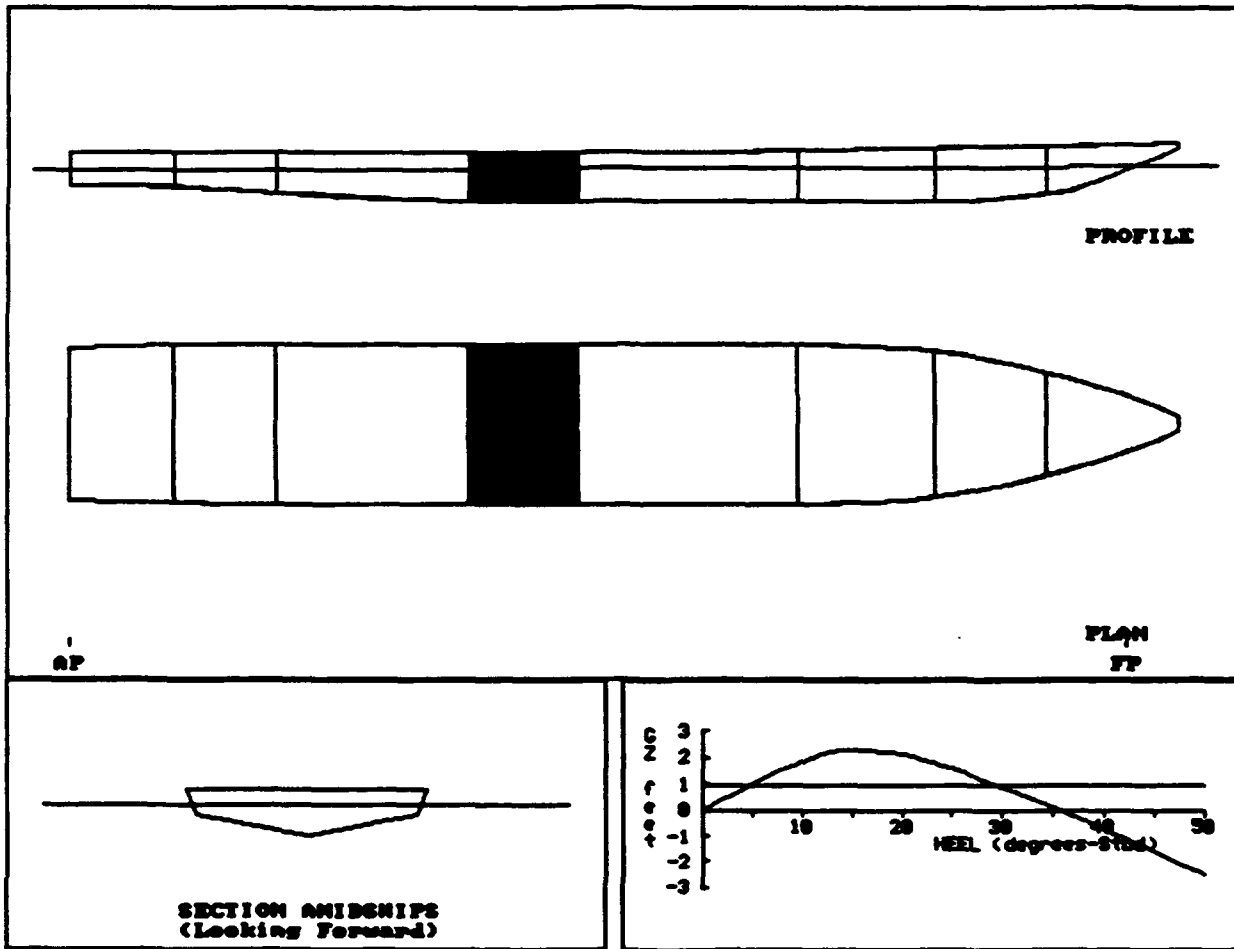

DPRT006A:
 192' DINNER BOAT

COMPARTMENT FLOODING SUMMARY

At 0.0o Heel	PERM.	FLOODED WTR LTons	% FULL (Damaged)	% FULL (Intact)	SP.VOL. ft3/LT	OUTFLOW LTons
TANKS	0.95	48.8	FREE	0.0	----	----
Totals		48.8				

INTACT DATA

Draft at AP = 6.520 ft	KMT = 28.589 ft	LCG = 80.996A ft-FP
Draft at FP = 7.310 ft	VCG = 16.010 ft	LCB = 80.938A ft-FP
Displacement = 425.5 LTons	Gmt = 12.579 ft	TGC = 0.000 ft-CL

DRAFT/GZ DATA

HEEL degrees	RIGHTING ARM ft	DRAFT AFT ft	DRAFT FWD ft	FLOODED WATER LTons
0.00	0.000	6.924	7.680	48.8
5.00S	0.989	6.918	7.638	48.7
7.00S	1.378	6.900	7.603	48.6
10.00S	1.858	6.820	7.522	48.2
15.00S	2.290	6.514	7.372	47.3
20.00S	2.107	6.290	7.198	46.9
30.00S	0.892	5.978	6.888	46.2
40.00S	-0.747	5.714	6.597	45.3
50.00S	-2.518	5.422	6.297	44.4

Note: Drafts are measured at A.P. and F.P along ship's centerline

GZ SUMMARY (Evaluated per IMO (SOLAS '90) Rules for Passenger Ships)

	Available	Required
Static Heel Angle	0.00 deg	7.00 deg
Angle at Maximum GZ	17.00S deg	
Maximum GZ	2.298 ft	0.970 ft
Range of Positive GZ	35.61 deg	15.00 deg
Gmt (upright damaged)	11.268 ft	
Righting Area (0.00-7.00)	35.557 ft-deg	2.820 ft-deg

DPRT007A:
 192' DINNER BOAT

Used Compartments:
 TANKS FUEL TANK(S)

	DISPLACEMENT LTons	DRAFT AFT ft	DRAFT FWD ft	TRIM ft	HEEL deg.	UPRIGHT GMT ft
INTACT	425.5	6.520	7.310	0.790F	0.00	12.579
DAMAGED	471.2	6.895	7.659	0.765F	0.50P	10.933

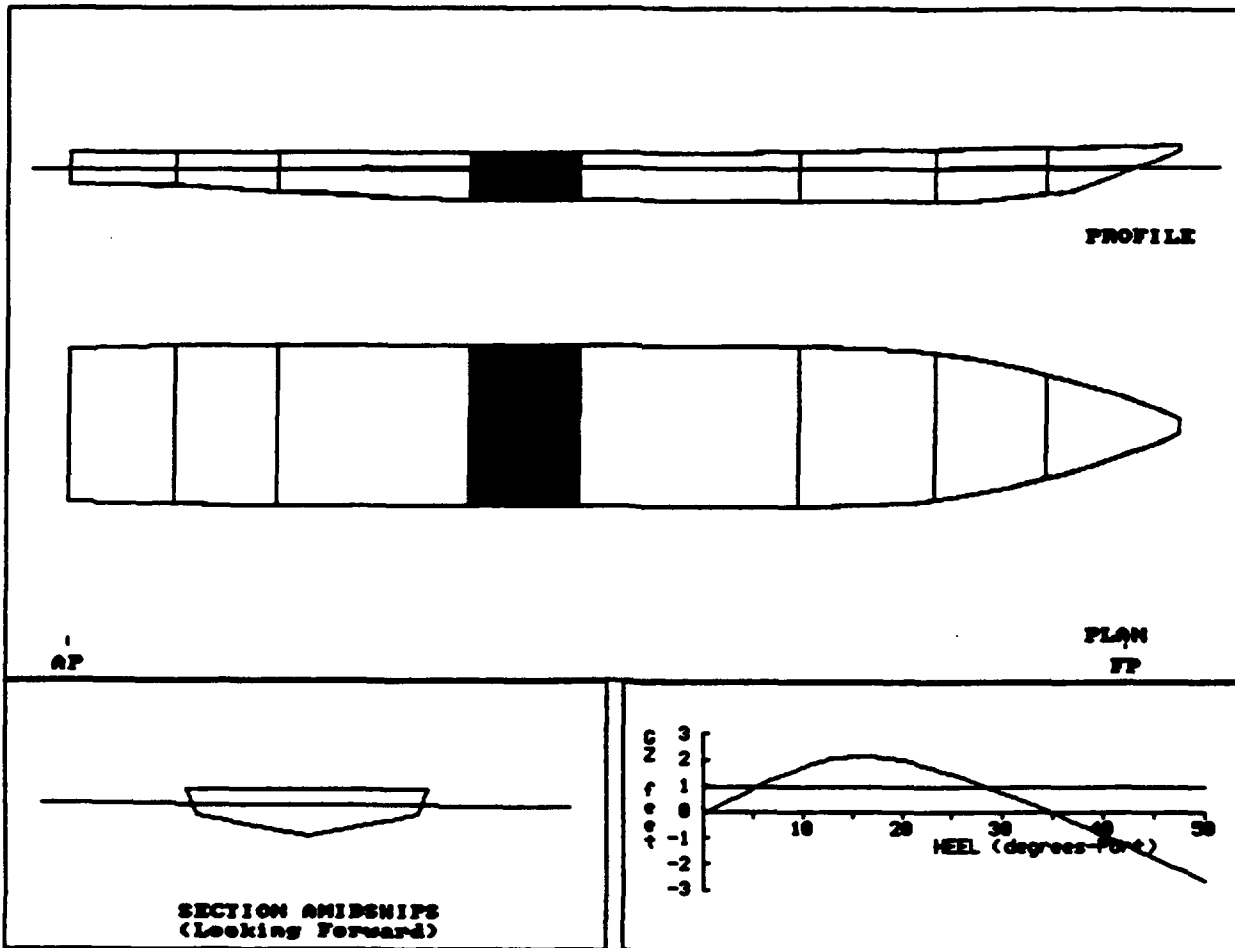

DPRT007A:
 192' DINNER BOAT

COMPARTMENT FLOODING SUMMARY

At 0.50P Heel	PERM.	FLOODED WTR LTons	% FULL (Damaged)	% FULL (Intact)	SP.VOL. ft ³ /LT	OUTFLOW LTons
TANKS	0.95	48.6	FREE	0.0	----	----
FUEL TANK(S)	0.95	2.0	FREE	100.0	40.6000	4.9
Totals		50.6				4.9

INTACT DATA

Draft at AP = 6.520 ft	Kmt = 28.589 ft	LCG = 80.996A ft-FP
Draft at FP = 7.310 ft	VCG = 16.010 ft	LCB = 80.938A ft-FP
Displacement = 425.5 LTons	Gmt = 12.579 ft	TCG = 0.000 ft-CL

DRAFT/GZ DATA

HEEL degrees	RIGHTING ARM ft	DRAFT AFT ft	DRAFT FWD ft	FLOODED WATER LTons
0.00	-0.096	6.896	7.664	50.8
5.00P	0.865	6.879	7.613	49.5
7.00P	1.239	6.855	7.578	48.9
10.00P	1.696	6.764	7.494	48.0
15.00P	2.125	6.442	7.343	46.9
20.00P	1.954	6.194	7.168	46.5
30.00P	0.748	5.831	6.856	45.8
40.00P	-0.886	5.506	6.558	44.8
50.00P	-2.652	5.133	6.249	44.0

Note: Drafts are measured at A.P. and F.P along ship's centerline

GZ SUMMARY (Evaluated per IMO (SOLAS'90) Rules for Passenger Ships)
 Available Required

Static Heel Angle	0.50P deg	7.00 deg
Angle at Maximum GZ	17.00P deg	
Maximum GZ	2.136 ft	0.970 ft
Range of Positive GZ	34.25 deg	15.00 deg
Righting Area (0.50-4.00)	32.390 ft-deg	2.820 ft-deg

DPR008A:
 192' DINNER BOAT

Imaged Compartments:
 ENGINE ROOM

	DISPLACEMENT LTons	DRAFT AFT ft	DRAFT FWD ft	TRIM ft	HEEL deg.	UPRIGHT GMT ft
INTACT	425.5	6.520	7.310	0.790F	0.00	12.579
DAMAGED	528.8	8.179	7.064	1.115A	0.00	9.028

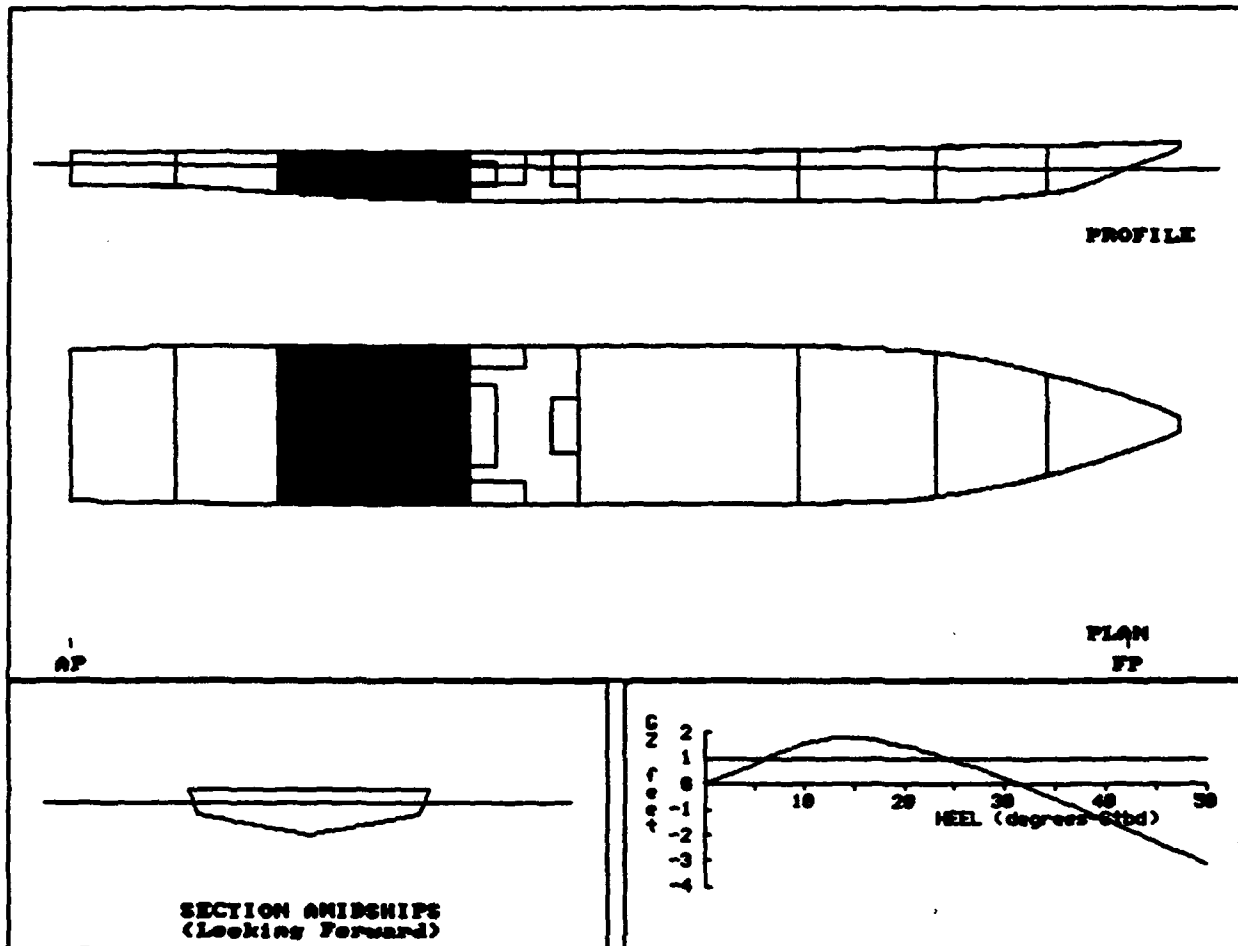

DPRT008A:
 192' DINNER BOAT

COMPARTMENT FLOODING SUMMARY

At 0.0o Heel	PERM.	FLOODED WTR LTons	% FULL (Damaged)	% FULL (Intact)	SP.VOL. ft3/LT	OUTFLOW LTons
ENGINE ROOM	0.85	103.3	FREE	0.0	----	----
Totals		103.3				

INTACT DATA

Draft at AP = 6.520 ft	Kmt = 28.589 ft	LCG = 80.996A ft-FP
Draft at FP = 7.310 ft	VCG = 16.010 ft	LCB = 80.938A ft-FP
Displacement = 425.5 LTons	Gmt = 12.579 ft	TCG = 0.000 ft-CL

DRAFT/GZ DATA

HEEL degrees	RIGHTING ARM ft	DRAFT AFT ft	DRAFT FWD ft	FLOODED WATER LTons
0.00	0.000	8.179	7.064	103.3
5.00S	0.793	8.179	7.012	103.4
7.00S	1.113	8.170	6.973	103.4
10.00S	1.573	8.147	6.884	103.2
15.00S	1.807	8.253	6.578	102.6
20.00S	1.498	8.513	6.218	102.2
30.00S	0.213	9.213	5.568	101.5
40.00S	-1.408	10.219	4.845	101.1
50.00S	-3.109	11.668	3.926	100.9

Note: Drafts are measured at A.P. and F.P along ship's centerline

GZ SUMMARY (Evaluated per IMO (SOLAS'90) Rules for Passenger Ships)
 Available Required

Static Heel Angle	0.00 deg	7.00 deg
Angle at Maximum GZ	15.00S deg	
Maximum GZ	1.813 ft	0.970 ft
Range of Positive GZ	31.38 deg	15.00 deg
Gmt (upright damaged)	9.028 ft	
Righting Area (0.00-3.00)	27.875 ft-deg	2.820 ft-deg

DPRT009A:
 192' DINNER BOAT

Imaged Compartments:
 MUFFLERS

	DISPLACEMENT LTons	DRAFT AFT ft	DRAFT FWD ft	TRIM ft	HEEL deg.	UPRIGHT Gmt ft
INTACT	425.5	6.520	7.310	0.790F	0.00	12.579
DAMAGED	469.0	7.560	6.770	0.790A	0.00	10.079

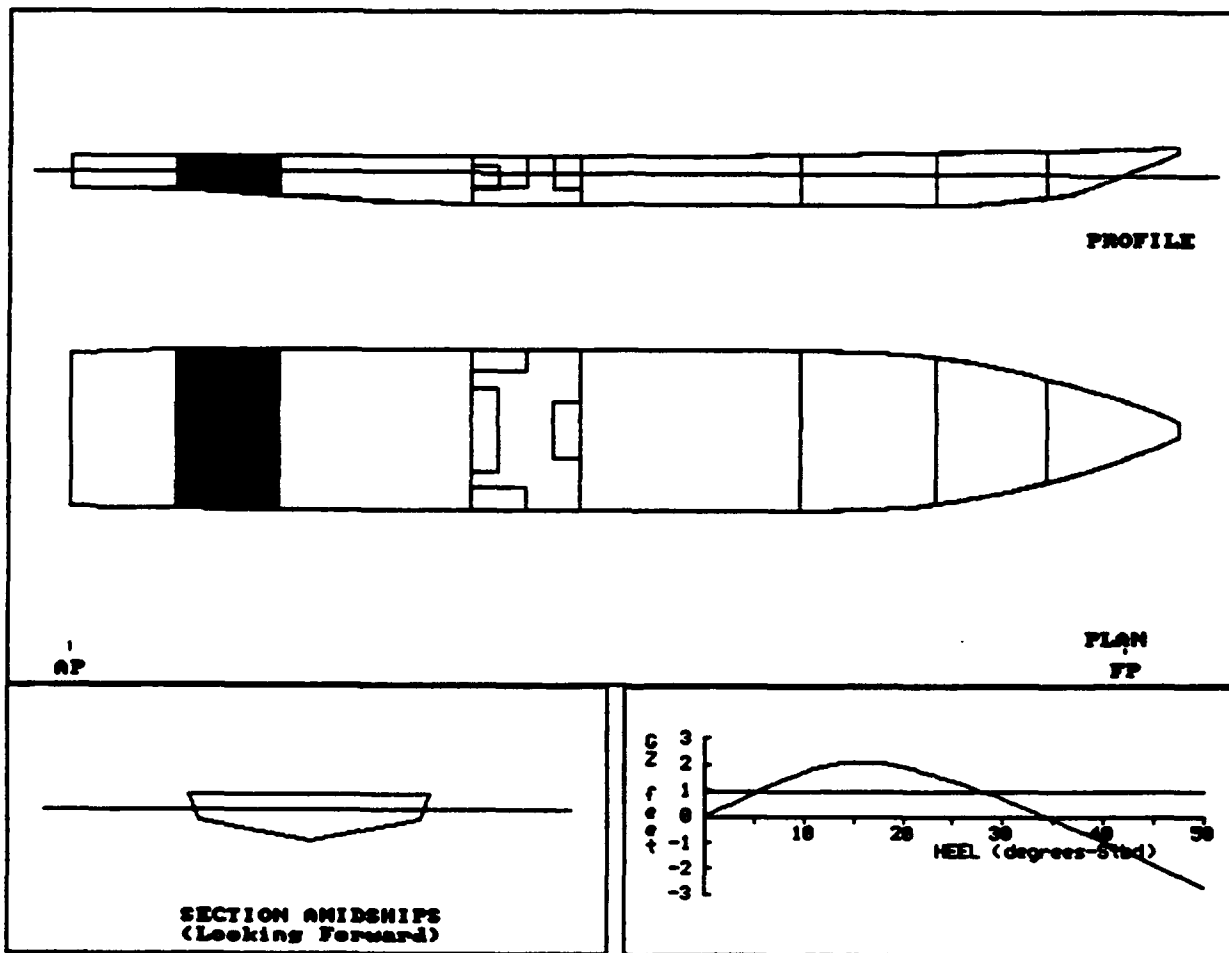

**DPR009A:
 192' DINNER BOAT**

COMPARTMENT FLOODING SUMMARY

At 0.0o Heel	PERM.	FLOODED WTR LTons	% FULL (Damaged)	% FULL (Intact)	SP.VOL. ft3/LT	OUTFLOW LTons
MUFLERS	0.95	43.6	FREE	0.0	----	----
Totals		43.6				

INTACT DATA

Draft at AP = 6.520 ft	KMt = 28.589 ft	LCG = 80.996A ft-FP
Draft at FP = 7.310 ft	VCG = 16.010 ft	LCB = 80.938A ft-FP
Displacement = 425.5 LTons	GMT = 12.579 ft	TCG = 0.000 ft-CL

DRAFT/GZ DATA

HEEL degrees	RIGHTING ARM ft	DRAFT AFT ft	DRAFT FWD ft	FLOODED WATER LTons
0.00	0.000	7.560	6.770	43.6
5.00S	0.882	7.564	6.717	43.7
7.00S	1.232	7.558	6.671	43.8
10.00S	1.695	7.505	6.583	43.9
15.00S	2.082	7.364	6.317	44.1
20.00S	1.886	7.358	5.971	44.6
30.00S	0.681	7.570	5.239	45.5
40.00S	-0.956	7.952	4.475	46.3
50.00S	-2.711	8.593	3.461	46.9

Note: Drafts are measured at A.P. and F.P along ship's centerline

GZ SUMMARY (Evaluated per IMO (SOLAS'90) Rules for Passenger Ships)

	Available	Required
Static Heel Angle	0.00 deg	7.00 deg
Angle at Maximum GZ	17.00S deg	
Maximum GZ	2.084 ft	0.970 ft
Range of Positive GZ	34.34 deg	15.00 deg
Gmt (upright damaged)	10.079 ft	
Righting Area (0.00-%.00)	32.117 ft-deg	2.820 ft-deg

DPRT010A:
 192' DINNER BOAT

Imaged Compartments:
 STEERING

	DISPLACEMENT LTons	DRAFT AFT ft	DRAFT FWD ft	TRIM ft	HEEL deg.	UPRIGHT GMT ft
INTACT	425.5	6.520	7.310	0.790F	0.00	12.579
DAMAGED	464.2	7.656	6.556	1.099A	0.00	10.138

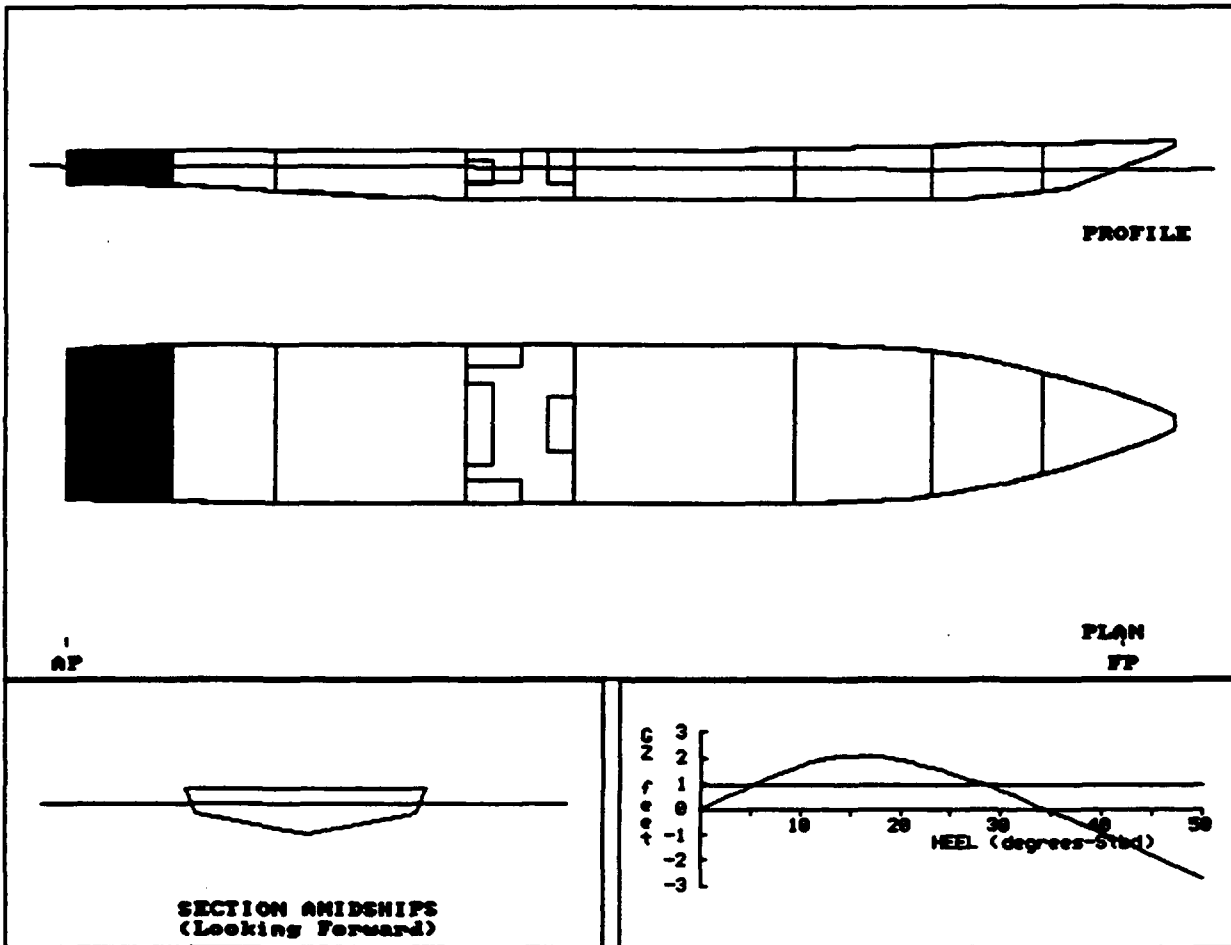

DPRT010A:
 192' DINNER BOAT

COMPARTMENT FLOODING SUMMARY

At 0.0o Heel	PERM.	FLOODED WTR LTons	% FULL (Damaged)	% FULL (Intact)	SP.VOL. ft3/LT	OUTFLOW LTons
STEERING	0.95	38.7	FREE	0.0	----	----
Totals		38.7				

INTACT DATA

Draft at AP = 6.520 ft	KMt = 28.589 ft	LCG = 80.996A ft-FP
Draft at FP = 7.310 ft	VCG = 16.010 ft	LCB = 80.938A ft-FP
Displacement = 425.5 LTons	GMT = 12.579 ft	TCG = 0.000 ft-CL

DRAFT/GZ DATA

HEEL degrees	RIGHTING ARM ft	DRAFT AFT ft	DRAFT FWD ft	FLOODED WATER LTons
0.00	0.000	7.656	6.556	38.7
5.00S	0.886	7.665	6.497	39.0
7.00S	1.236	7.663	6.446	39.1
10.00S	1.697	7.612	6.352	39.2
15.00S	2.081	7.498	6.060	39.6
20.00S	1.891	7.543	5.660	40.5
30.00S	0.692	7.900	4.779	42.2
40.00S	-0.947	8.462	3.837	43.4
50.00S	-2.707	9.318	2.625	44.4

Note: Drafts are measured at A.P. and F.P along ship's centerline

GZ SUMMARY (Evaluated per IMO (SOLAS'90) Rules for Passenger Ships)

	Available	Required
Static Heel Angle	0.00 deg	7.00 deg
Angle at Maximum GZ	17.00S deg	
Maximum GZ	2.084 ft	0.970 ft
Range of Positive GZ	34.40 deg	15.00 deg
Gmt (upright damaged)	10.138 ft	
Righting Area (0.00-%.00)	32.171 ft-deg	2.820 ft-deg

RTRN001A:
 192' DINNER BOAT

Imaged Compartments:
 FOREPEAK

	DISPLACEMENT LTons	DRAFT AFT ft	DRAFT FWD ft	TRIM ft	HEEL deg.	UPRIGHT GMT ft
INTACT	417.8	6.410	7.310	0.900F	0.00	12.914
DAMAGED	421.3	6.339	7.465	1.127F	0.00	12.863

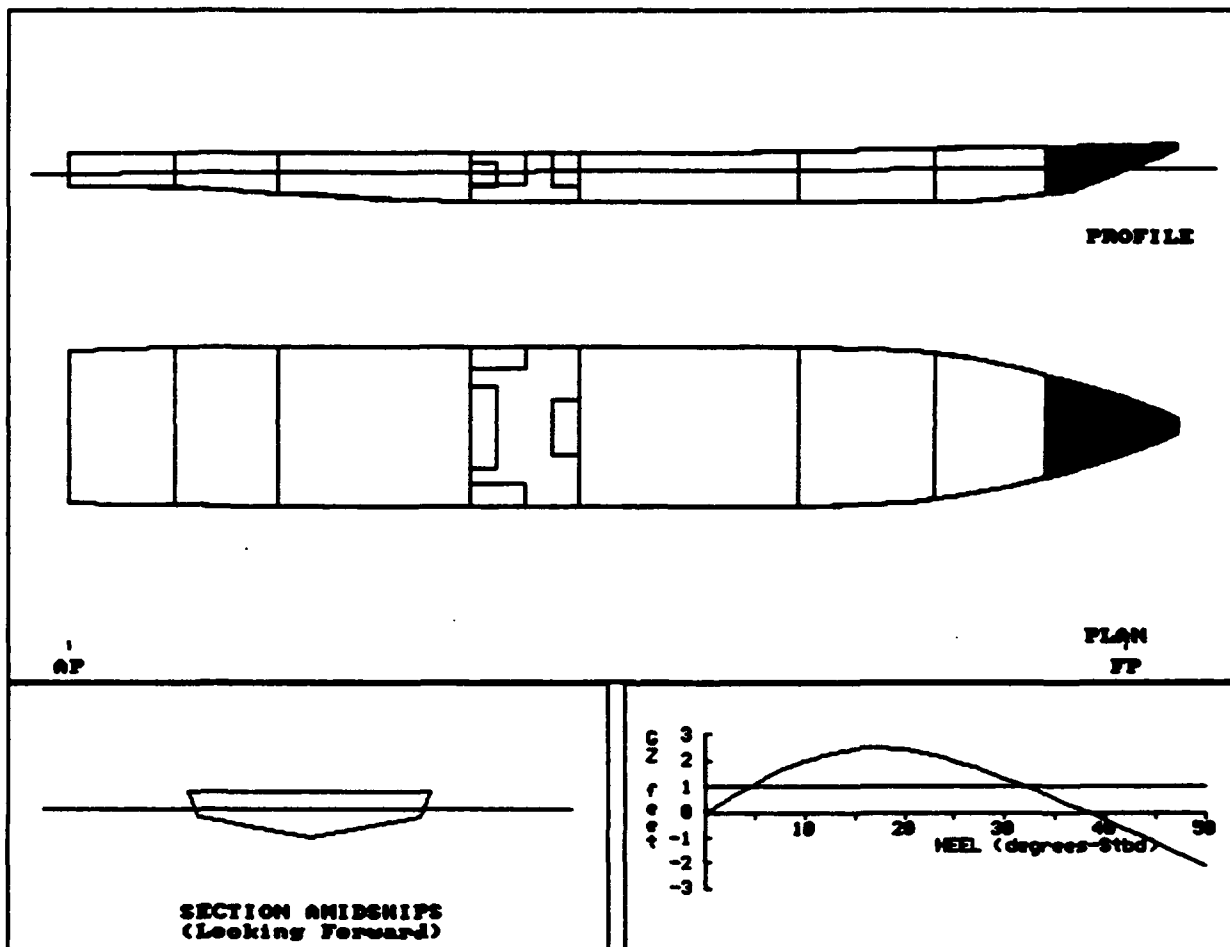

RTRN001A:
 192' DINNER BOAT

COMPARTMENT FLOODING SUMMARY

At 0.0o Heel	PERM.	FLOODED WTR LTons	% FULL (Damaged)	% FULL (Intact)	SP.VOL. ft3/LT	OUTFLOW LTons
FOREPEAK	0.95	3.5	FREE	0.0	----	----
Totals		3.5				

INTACT DATA

Draft at AP = 6.410 ft KMT = 28.904 ft LCG = 80.580A ft-FP
 Draft at FP = 7.310 ft VCG = 15.990 ft LCB = 80.515A ft-FP
 Displacement = 417.8 LTons GMT = 12.914 ft TCG = 0.000 ft-CL

DRAFT/GZ DATA

HEEL degrees	RIGHTING ARM ft	DRAFT AFT ft	DRAFT FWD ft	FLOODED WATER LTons
0.00	0.000	6.339	7.465	3.5
5.00S	1.115	6.326	7.424	3.5
7.00S	1.506	6.280	7.400	3.4
10.00S	1.959	6.150	7.329	3.3
15.00S	2.436	5.748	7.171	3.2
20.00S	2.413	5.300	6.991	3.0
30.00S	1.320	4.472	6.712	3.3
40.00S	-0.314	3.563	6.520	4.4
50.00S	-2.133	2.382	6.407	5.7

Note: Drafts are measured at A.P. and F.P along ship's centerline

GZ SUMMARY (Evaluated per IMO (SOLAS'90) Rules for Passenger Ships)
 Available Required

Static Heel Angle	0.00 deg	7.00 deg
Angle at Maximum GZ	18.00S deg	
Maximum GZ	2.486 ft	0.980 ft
Range of Positive GZ	38.20 deg	15.00 deg
Gmt (upright damaged)	12.863 ft	
Righting Area (0.00-3.00)	38.847 ft-deg	2.820 ft-deg

RTRN002A:
 192' DINNER BOAT

aged Compartments:
 FOREPEAK BOW THRUSTER

	DISPLACEMENT LTons	DRAFT AFT ft	DRAFT FWD ft	TRIM ft	HEEL deg.	UPRIGHT GMT ft
INTACT	417.8	6.410	7.310	0.900F	0.00	12.914
DAMAGED	454.9	5.833	8.695	2.861F	0.00	13.005

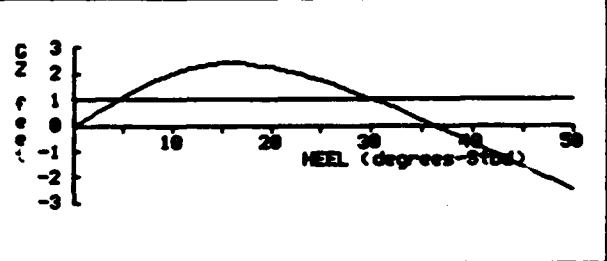
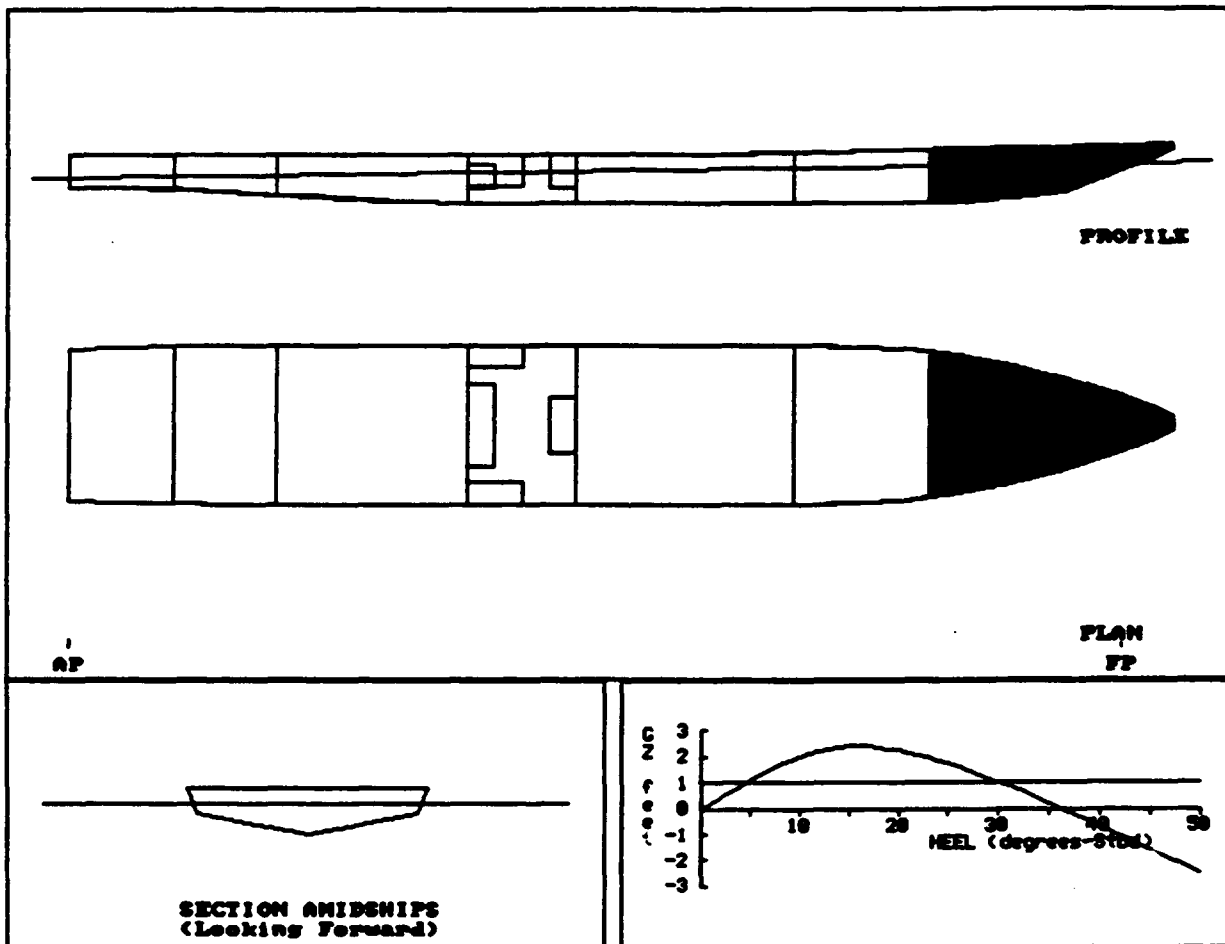

RTRN002A:
 192' DINNER BOAT

COMPARTMENT FLOODING SUMMARY

At 0.0o Heel	PERM.	FLOODED WTR LTons	% FULL (Damaged)	% FULL (Intact)	SP.VOL. ft3/LT	OUTFLOW LTons
FOREPEAK	0.95	5.7	FREE	0.0	----	----
BOW THUSTER	0.95	31.4	FREE	0.0	----	----
Totals		37.1				

INTACT DATA

Draft at AP = 6.410 ft	Kmt = 28.904 ft	LCG = 80.580A ft-FP
Draft at FP = 7.310 ft	VCG = 15.990 ft	LCB = 80.515A ft-FP
Displacement = 417.8 LTons	Gmt = 12.914 ft	TCG = 0.000 ft-CL

DRAFT/GZ DATA

HEEL degrees	RIGHTING ARM ft	DRAFT AFT ft	DRAFT FWD ft	FLOODED WATER LTons
0.00	0.000	5.833	8.695	37.1
5.00S	1.099	5.784	8.691	37.4
7.00S	1.488	5.709	8.702	37.8
10.00S	1.972	5.530	8.709	38.6
15.00S	2.402	5.066	8.722	40.6
20.00S	2.248	4.457	8.955	44.7
30.00S	1.015	3.078	9.857	52.8
40.00S	-0.682	1.442	11.162	58.6
50.00S	-2.514	-0.754	13.087	62.9

Note: Drafts are measured at A.P. and F.P along ship's centerline

GZ SUMMARY (Evaluated per IMO (SOLAS'90) Rules for Passenger Ships)
 Available Required

Static Heel Angle	0.00 deg	7.00 deg
Angle at Maximum GZ	17.00S deg	
Maximum GZ	2.414 ft	0.980 ft
Range of Positive GZ	36.14 deg	15.00 deg
Gmt (upright damaged)	13.005 ft	
Righting Area (0.00-7.00)	37.915 ft-deg	2.820 ft-deg

RTRN003A:
 192' DINNER BOAT

Imaged Compartments:
 BOW TRUSTER

	DISPLACEMENT LTons	DRAFT AFT ft	DRAFT FWD ft	TRIM ft	HEEL deg.	UPRIGHT GMT ft
INTACT	417.8	6.410	7.310	0.900F	0.00	12.914
DAMAGED	447.2	5.970	8.391	2.421F	0.00	12.904

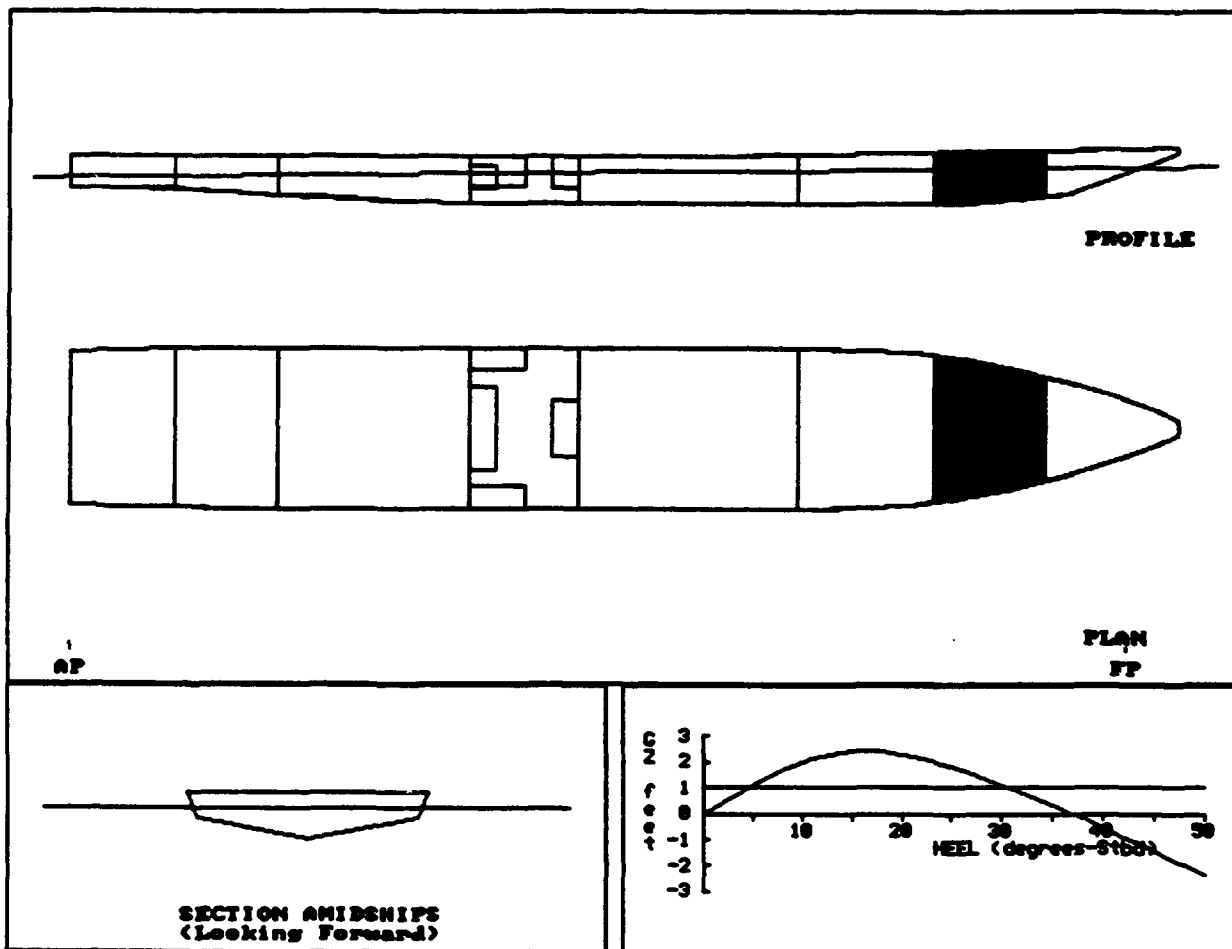

RTRN003A:
 192' DINNER BOAT

COMPARTMENT FLOODING SUMMARY

At 0.0o Heel	PERM.	FLOODED WTR LTons	% FULL (Damaged)	% FULL (Intact)	SP.VOL. ft3/LT	OUTFLOW LTons
BOW THUSTER	0.95	29.4	FREE	0.0	----	----
Totals		29.4				

INTACT DATA

Draft at AP = 6.410 ft	KMT = 28.904 ft	LCG = 80.580A ft-FP
Draft at FP = 7.310 ft	VCG = 15.990 ft	LCB = 80.515A ft-FP
Displacement = 417.8 LTons	GMT = 12.914 ft	TCG = 0.000 ft-CL

DRAFT/GZ DATA

HEEL degrees	RIGHTING ARM ft	DRAFT AFT ft	DRAFT FWD ft	FLOODED WATER LTons
0.00	0.000	5.970	8.391	29.4
5.00S	1.101	5.931	8.379	29.6
7.00S	1.490	5.864	8.382	29.9
10.00S	1.965	5.698	8.370	30.4
15.00S	2.416	5.267	8.309	31.6
20.00S	2.290	4.707	8.417	34.0
30.00S	1.119	3.619	8.729	36.8
40.00S	-0.533	2.426	9.180	38.2
50.00S	-2.341	0.882	9.885	39.1

Note: Drafts are measured at A.P. and F.P along ship's centerline

GZ SUMMARY (Evaluated per IMO (SOLAS'90) Rules for Passenger Ships)

	Available	Required
Static Heel Angle	0.00 deg	7.00 deg
Angle at Maximum GZ	17.00S deg	
Maximum GZ	2.434 ft	0.980 ft
Range of Positive GZ	36.93 deg	15.00 deg
Gmt (upright damaged)	12.904 ft	
Righting Area (0.00-7.00)	38.152 ft-deg	2.820 ft-deg

RTRN004A:
 192' DINNER BOAT

Imaged Compartments:
 TOILET SPACE

	DISPLACEMENT LTons	DRAFT AFT ft	DRAFT FWD ft	TRIM ft	HEEL deg.	UPRIGHT GMT ft
INTACT	417.8	6.410	7.310	0.900F	0.00	12.914
DAMAGED	495.3	5.753	9.485	3.733F	0.00	11.668

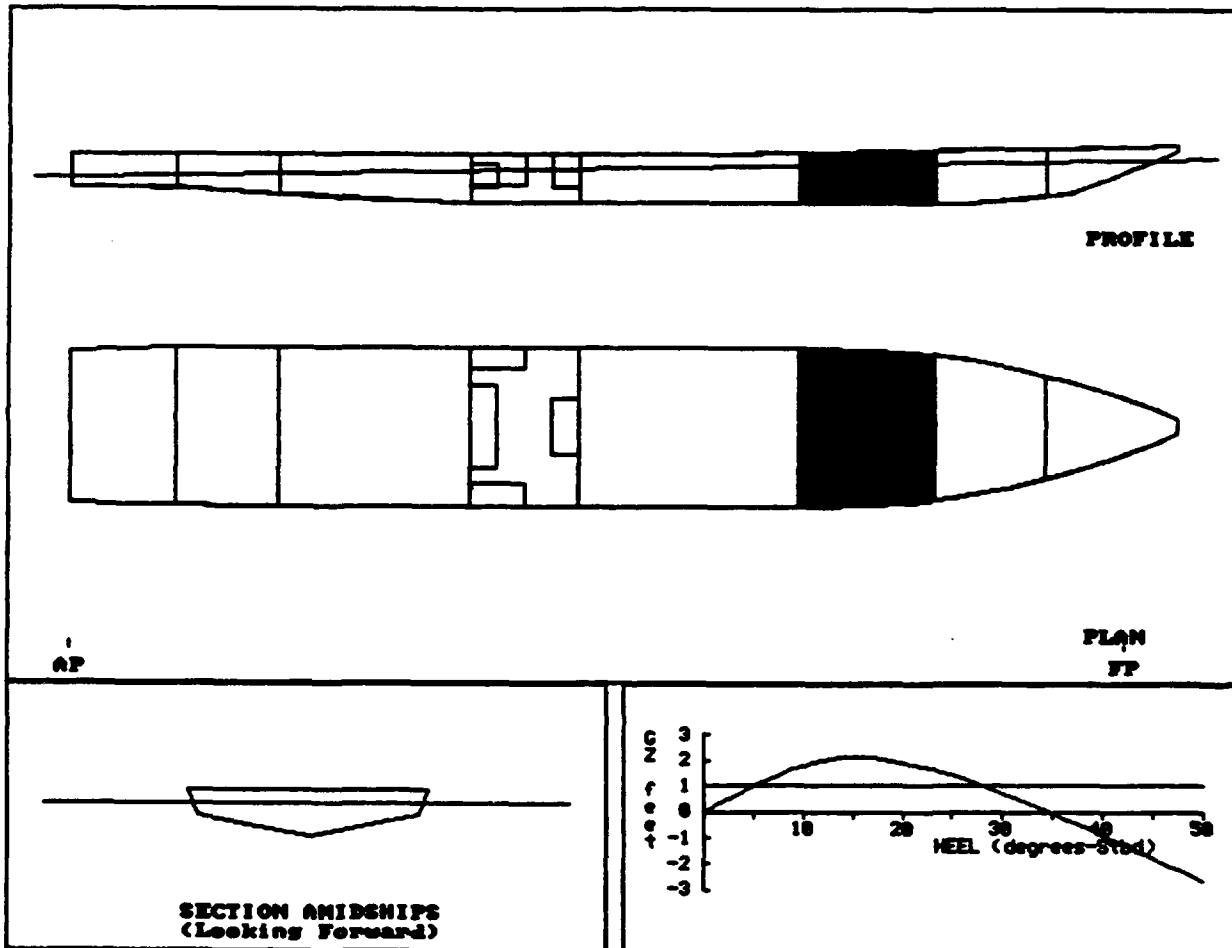

RTRN004A:
 192' DINNER BOAT

COMPARTMENT FLOODING SUMMARY

At 0.0o Heel	PERM.	FLOODED WTR LTons	% FULL (Damaged)	% FULL (Intact)	SP.VOL. ft3/LT	OUTFLOW LTons
TOILET SPACE	0.95	77.5	FREE	0.0	----	----
Totals		77.5				

INTACT DATA

Draft at AP = 6.410 ft	KMt = 28.904 ft	LCG = 80.580A ft-FP
Draft at FP = 7.310 ft	VCG = 15.990 ft	LCB = 80.515A ft-FP
Displacement = 417.8 LTons	GMT = 12.914 ft	TCG = 0.000 ft-CL

DRAFT/GZ DATA

HEEL degrees	RIGHTING ARM ft	DRAFT AFT ft	DRAFT FWD ft	FLOODED WATER LTons
0.00	0.000	5.753	9.485	77.5
5.00S	0.982	5.710	9.470	77.8
7.00S	1.331	5.643	9.472	78.2
10.00S	1.786	5.477	9.479	78.9
15.00S	2.123	5.054	9.537	79.1
20.00S	1.941	4.564	9.698	78.6
30.00S	0.737	3.540	10.260	77.8
40.00S	-0.892	2.416	11.035	77.0
50.00S	-2.651	0.929	12.249	76.5

Note: Drafts are measured at A.P. and F.P along ship's centerline

GZ SUMMARY (Evaluated per IMO (SOLAS'90) Rules for Passenger Ships)

	Available	Required
Static Heel Angle	0.00 deg	7.00 deg
Angle at Maximum GZ	16.00S deg	
Maximum GZ	2.123 ft	0.980 ft
Range of Positive GZ	34.69 deg	15.00 deg
Gmt (upright damaged)	11.668 ft	
Righting Area (0.00-7.00)	33.572 ft-deg	2.820 ft-deg

RTRN005A:
 192' DINNER BOAT

Imaged Compartments:
 GALLEY

	DISPLACEMENT LTons	DRAFT AFT ft	DRAFT FWD ft	TRIM ft	HEEL deg.	UPRIGHT GMT ft
INTACT	417.8	6.410	7.310	0.900F	0.00	12.914
DAMAGED	576.6	6.495	9.963	3.468F	0.00	9.630

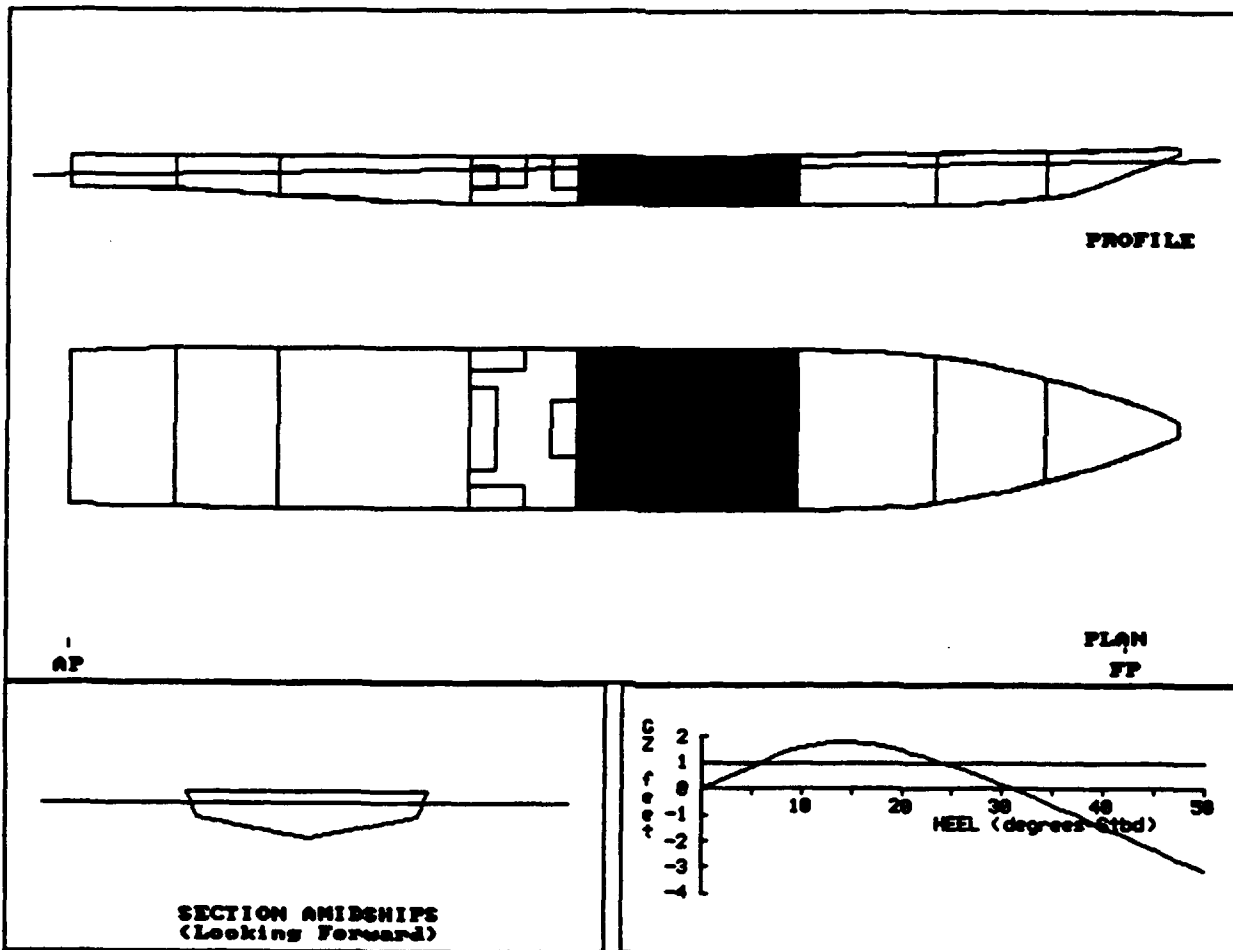

RTRN005A:
 192' DINNER BOAT

COMPARTMENT FLOODING SUMMARY

At 0.0o Heel	PERM.	FLOODED WTR LTons	% FULL (Damaged)	% FULL (Intact)	SP.VOL. ft3/LT	OUTFLOW LTons
GALLEY	0.95	158.8	FREE	0.0	----	----
Totals		158.8				

INTACT DATA

Draft at AP = 6.410 ft	Kmt = 28.904 ft	LCG = 80.580A ft-FP
Draft at FP = 7.310 ft	VCG = 15.990 ft	LCB = 80.515A ft-FP
Displacement = 417.8 LTons	Gmt = 12.914 ft	TCG = 0.000 ft-CL

DRAFT/GZ DATA

HEEL degrees	RIGHTING ARM ft	DRAFT AFT ft	DRAFT FWD ft	FLOODED WATER LTons
0.00	0.000	6.495	9.963	158.8
5.00S	0.846	6.492	9.907	158.4
7.00S	1.172	6.467	9.871	158.1
10.00S	1.590	6.374	9.829	156.5
15.00S	1.795	6.104	9.900	151.5
20.00S	1.467	5.856	10.078	147.6
30.00S	0.159	5.466	10.587	142.4
40.00S	-1.456	5.058	11.393	139.1
50.00S	-3.136	4.593	12.554	136.7

Note: Drafts are measured at A.P. and F.P along ship's centerline

GZ SUMMARY (Evaluated per IMO (SOLAS'90) Rules for Passenger Ships)
 Available Required

Static Heel Angle	0.00 deg	7.00 deg
Angle at Maximum GZ	15.00S deg	
Maximum GZ	1.804 ft	0.980 ft
Range of Positive GZ	31.03 deg	15.00 deg
Gmt (upright damaged)	9.630 ft	
Righting Area (0.00-7.00)	28.065 ft-deg	2.820 ft-deg

RTRN006A:
 192' DINNER BOAT

Imaged Compartments:
 TANKS

	DISPLACEMENT LTons	DRAFT AFT ft	DRAFT FWD ft	TRIM ft	HEEL deg.	UPRIGHT Gmt ft
INTACT	417.8	6.410	7.310	0.900F	0.00	12.914
DAMAGED	466.0	6.810	7.675	0.866F	0.00	11.569

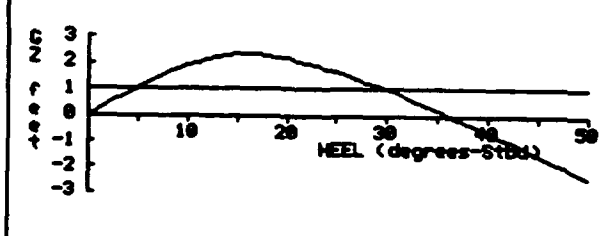
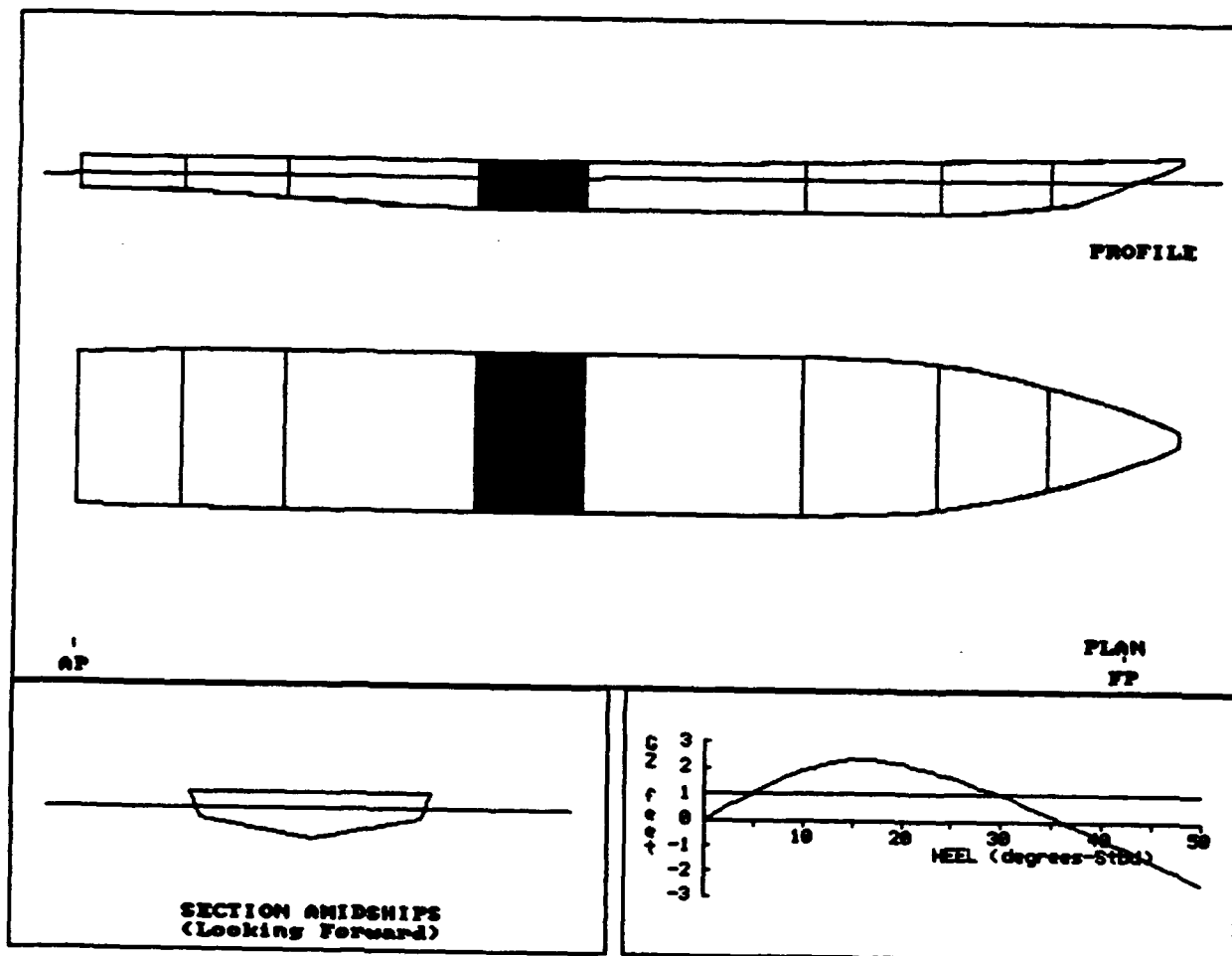

RTRN006A:
 192' DINNER BOAT

COMPARTMENT FLOODING SUMMARY

At 0.0o Heel	PERM.	FLOODED WTR LTons	% FULL (Damaged)	% FULL (Intact)	SP.VOL. ft3/LT	OUTFLOW LTons
TANKS	0.95	48.2	FREE	0.0	----	----
Totals		48.2				

INTACT DATA

Draft at AP = 6.410 ft	Kmt = 28.904 ft	LCG = 80.580A ft-FP
Draft at FP = 7.310 ft	VCG = 15.990 ft	LCB = 80.515A ft-FP
Displacement = 417.8 LTons	Gmt = 12.914 ft	TCG = 0.000 ft-CL

DRAFT/GZ DATA

HEEL degrees	RIGHTING ARM ft	DRAFT AFT ft	DRAFT FWD ft	FLOODED WATER LTons
0.00	0.000	6.810	7.675	48.2
5.00S	1.015	6.803	7.634	48.1
7.00S	1.407	6.781	7.601	48.0
10.00S	1.883	6.690	7.523	47.5
15.00S	2.329	6.358	7.375	46.6
20.00S	2.173	6.087	7.207	46.2
30.00S	0.980	5.674	6.909	45.5
40.00S	-0.653	5.285	6.633	44.5
50.00S	-2.428	4.825	6.352	43.7

Note: Drafts are measured at A.P. and F.P along ship's centerline

GZ SUMMARY (Evaluated per IMO (SOLAS'90) Rules for Passenger Ships)

	Available	Required
Static Heel Angle	0.00 deg	7.00 deg
Angle at Maximum GZ	17.00S deg	
Maximum GZ	2.343 ft	0.980 ft
Range of Positive GZ	36.17 deg	15.00 deg
Gmt (upright damaged)	11.569 ft	
Righting Area (0.00-7.00)	36.321 ft-deg	2.820 ft-deg

RTRN007A:
 192' DINNER BOAT

Imaged Compartments:

TANKS FUEL TANK(S)

	DISPLACEMENT LTons	DRAFT AFT ft	DRAFT FWD ft	TRIM ft	HEEL deg.	UPRIGHT Gmt ft
INTACT	417.8	6.410	7.310	0.900F	0.00	12.914
DAMAGED	467.8	6.828	7.684	0.856F	0.29S	11.164

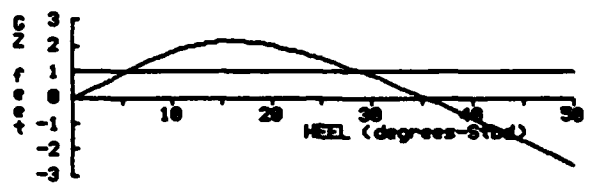
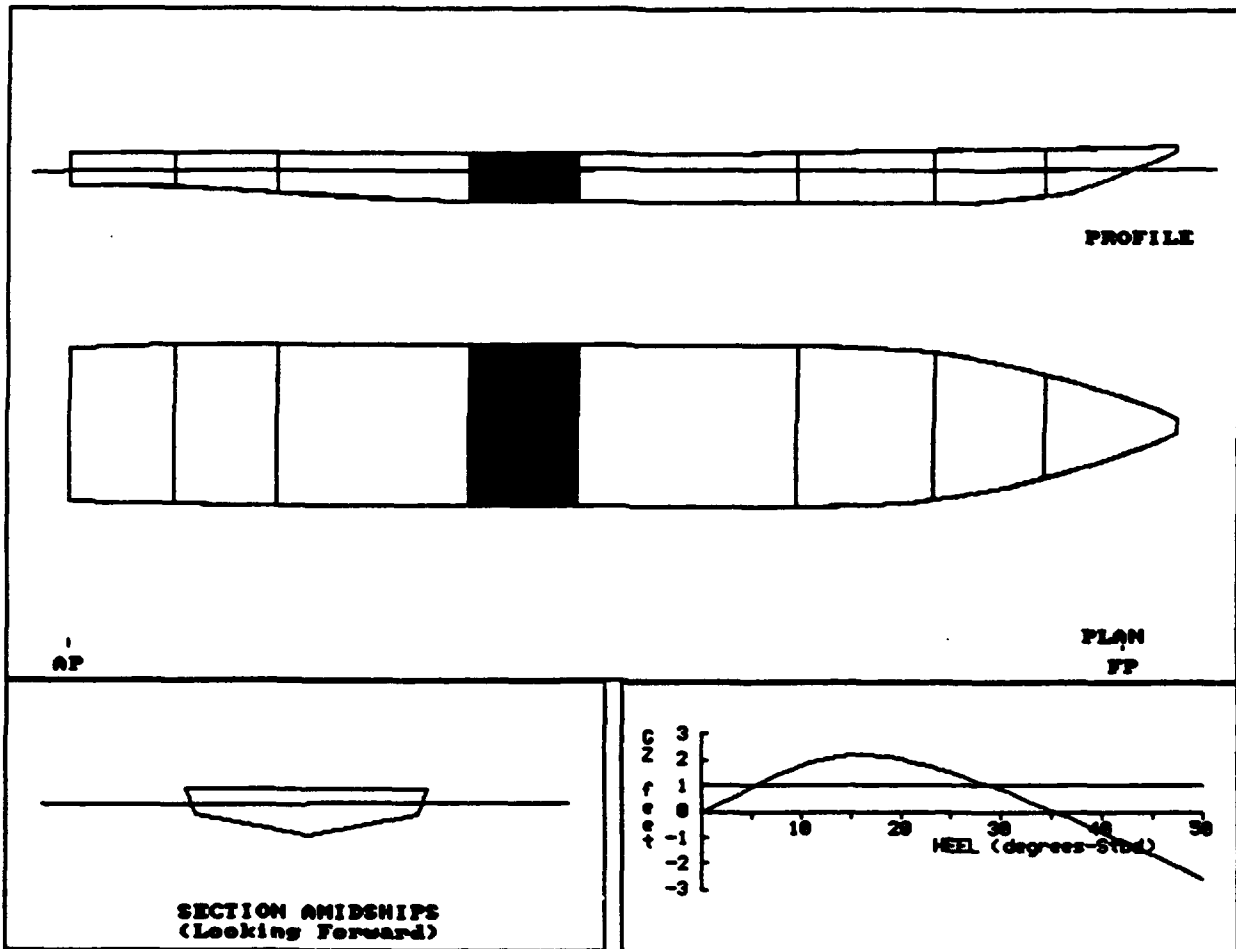

RTRN007A:
 192' DINNER BOAT

COMPARTMENT FLOODING SUMMARY

At 0.3oS Heel	PERM.	FLOODED WTR LTons	% FULL (Damaged)	% FULL (Intact)	SP.VOL. ft ³ /LT	OUTFLOW LTons
TANKS	0.95	48.3	FREE	0.0	----	----
FUEL TANK(S)	0.95	2.2	FREE	10.0	40.6000	0.5
Totals		50.5				0.5

INTACT DATA

Draft at AP = 6.410 ft	KMt = 28.904 ft	LCG = 80.580A ft-FP
Draft at FP = 7.310 ft	VCG = 15.990 ft	LCB = 80.515A ft-FP
Displacement = 417.8 LTons	GMT = 12.914 ft	TCG = 0.000 ft-CL

DRAFT/GZ DATA

HEEL degrees	RIGHTING ARM ft	DRAFT AFT ft	DRAFT FWD ft	FLOODED WATER LTons
0.00	-0.057	6.827	7.685	50.5
5.00S	0.922	6.831	7.653	51.6
7.00S	1.302	6.817	7.622	52.0
10.00S	1.766	6.737	7.548	52.4
15.00S	2.191	6.433	7.404	52.5
20.00S	2.025	6.188	7.239	52.3
30.00S	0.833	5.829	6.942	51.6
40.00S	-0.793	5.505	6.673	50.6
50.00S	-2.553	5.132	6.403	49.8

Note: Drafts are measured at A.P. and F.P along ship's centerline

GZ SUMMARY (Evaluated per IMO (SOLAS'90) Rules for Passenger Ships)

	Available	Required
Static Heel Angle	0.29S deg	7.00 deg
Angle at Maximum GZ	17.00S deg	
Maximum GZ	2.201 ft	0.980 ft
Range of Positive GZ	35.01 deg	15.00 deg
Righting Area (0.29-15.00)	33.762 ft-deg	2.820 ft-deg

RTRNO08A:
 192' DINNER BOAT

Damaged Compartments:
 ENGINE ROOM

	DISPLACEMENT LTons	DRAFT AFT ft	DRAFT FWD ft	TRIM ft	HEEL deg.	UPRIGHT GMT ft
INTACT	417.8	6.410	7.310	0.900F	0.00	12.914
DAMAGED	518.8	8.033	7.069	0.964A	0.00	9.278

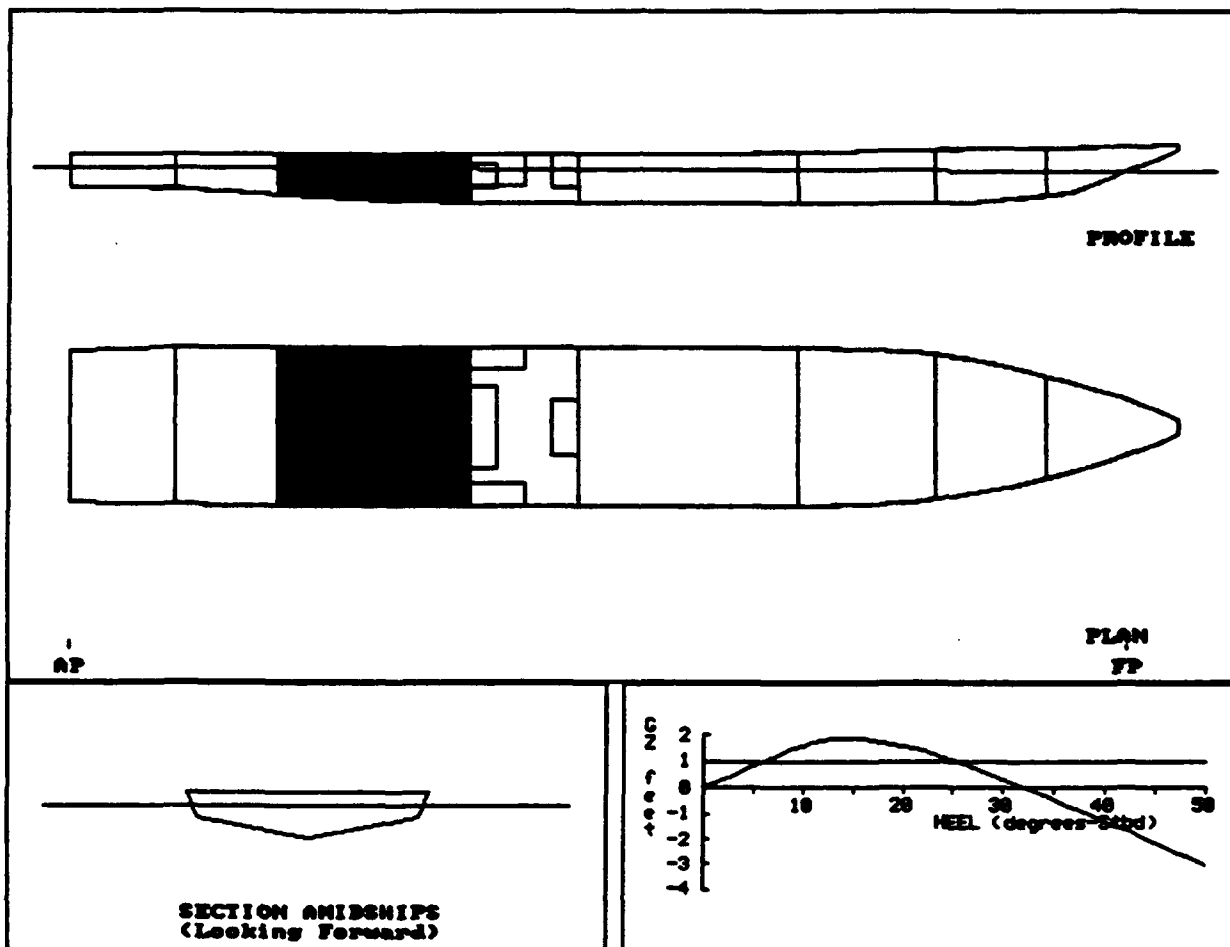

RTRN008A:
 192' DINNER BOAT

COMPARTMENT FLOODING SUMMARY

At 0.0o Heel	PERM.	FLOODED WTR LTons	% FULL (Damaged)	% FULL (Intact)	SP.VOL. ft3/LT	OUTFLOW LTons
ENGINE ROOM	0.85	101.0	FREE	0.0	----	----
Totals		101.0				

INTACT DATA

Draft at AP = 6.410 ft	KMt = 28.904 ft	LCG = 80.580A ft-FP
Draft at FP = 7.310 ft	VCG = 15.990 ft	LCB = 80.515A ft-FP
Displacement = 417.8 LTons	GMT = 12.914 ft	TCG = 0.000 ft-CL

DRAFT/GZ DATA

HEEL degrees	RIGHTING ARM ft	DRAFT AFT ft	DRAFT FWD ft	FLOODED WATER LTons
0.00	0.000	8.033	7.069	101.0
5.00S	0.814	8.033	7.019	101.1
7.00S	1.142	8.024	6.979	101.0
10.00S	1.614	7.993	6.893	100.8
15.00S	1.885	8.035	6.602	100.2
20.00S	1.599	8.213	6.273	99.7
30.00S	0.329	8.787	5.631	99.0
40.00S	-1.291	9.621	4.935	98.6
50.00S	-3.000	10.836	4.055	98.3

Note: Drafts are measured at A.P. and F.P along ship's centerline

GZ SUMMARY (Evaluated per IMO (SOLAS'90) Rules for Passenger Ships)

	Available	Required
Static Heel Angle	0.00 deg	7.00 deg
Angle at Maximum GZ	16.00S deg	
Maximum GZ	1.885 ft	0.980 ft
Range of Positive GZ	32.13 deg	15.00 deg
Gmt (upright damaged)	9.278 ft	
Righting Area (0.00-7.00)	29.045 ft-deg	2.820 ft-deg

RTRN009A:
 192' DINNER BOAT

Imaged Compartments:
 MUFFERS

	DISPLACEMENT LTons	DRAFT AFT ft	DRAFT FWD ft	TRIM ft	HEEL deg.	UPRIGHT GMT ft
INTACT	417.8	6.410	7.310	0.900F	0.00	12.914
DAMAGED	459.7	7.412	6.790	0.622A	0.00	10.359

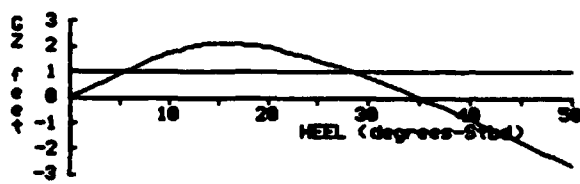
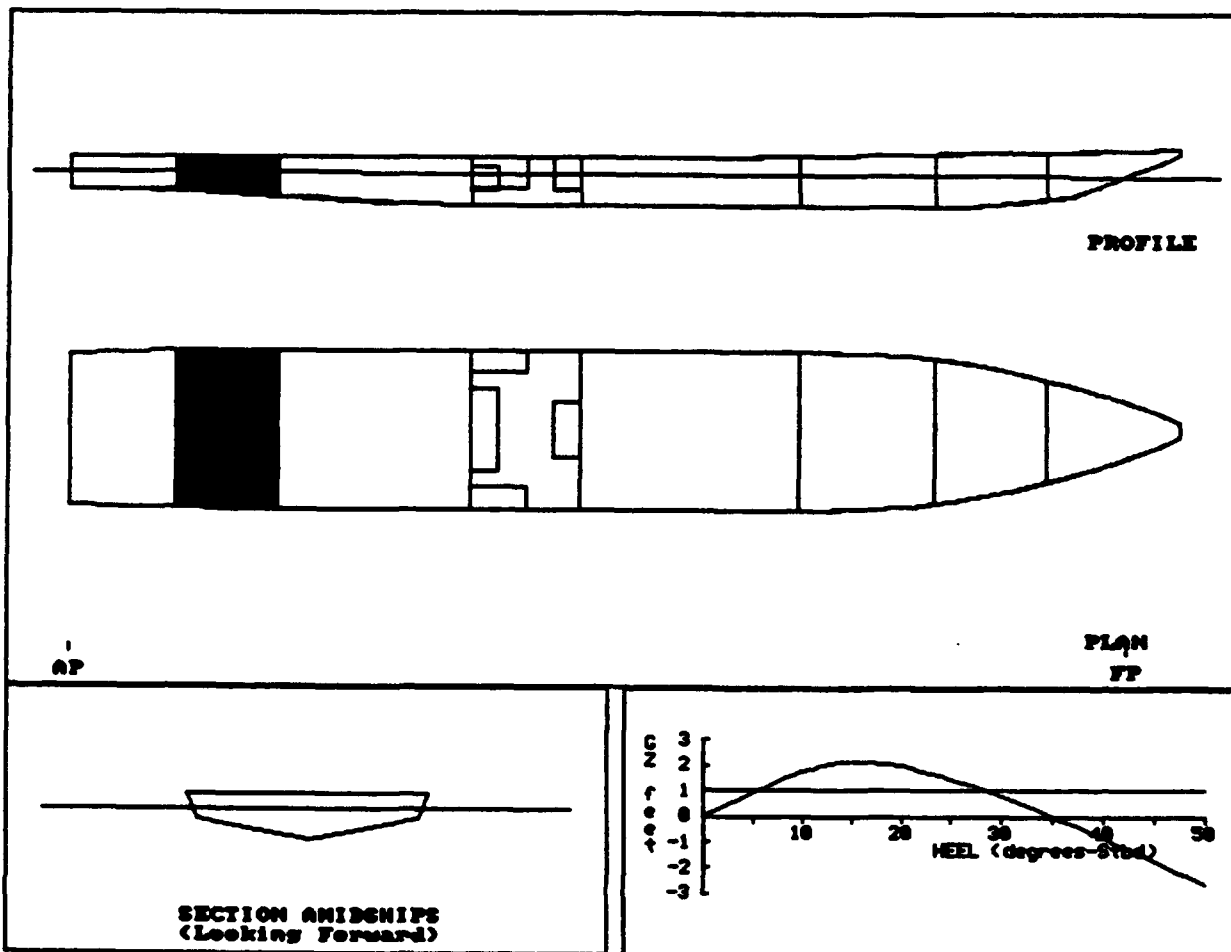

RTRN009A:
192' DINNER BOAT

COMPARTMENT FLOODING SUMMARY

At 0.0o Heel	PERM.	FLOODED WTR LTons	% FULL (Damaged)	% FULL (Intact)	SP.VOL. ft3/LT	OUTFLOW LTons
MUFLERS	0.95	41.9	FREE	0.0	----	----
Totals		41.9				

INTACT DATA

Draft at AP = 6.410 ft Kmt = 28.904 ft LCG = 80.580A ft-FP
 Draft at FP = 7.310 ft VCG = 15.990 ft LCB = 80.515A ft-FP
 Displacement = 417.8 LTons GMT = 12.914 ft TCG = 0.000 ft-CL

DRAFT/GZ DATA

HEEL degrees	RIGHTING ARM ft	DRAFT AFT ft	DRAFT FWD ft	FLOODED WATER LTons
0.00	0.000	7.412	6.790	41.9
5.00S	0.906	7.415	6.738	42.1
7.00S	1.265	7.410	6.691	42.1
10.00S	1.724	7.345	6.606	42.2
15.00S	2.134	7.158	6.355	42.5
20.00S	1.965	7.093	6.022	43.0
30.00S	0.783	7.175	5.320	43.9
40.00S	-0.850	7.400	4.587	44.7
50.00S	-2.609	7.831	3.613	45.3

Note: Drafts are measured at A.P. and F.P along ship's centerline

GZ SUMMARY (Evaluated per IMO (SOLAS'90) Rules for Passenger Ships)

	Available	Required
Static Heel Angle	0.00 deg	7.00 deg
Angle at Maximum GZ	17.00S deg	
Maximum GZ	2.143 ft	0.980 ft
Range of Positive GZ	34.98 deg	15.00 deg
Gmt (upright damaged)	10.359 ft	
Righting Area (0.00-%.00)	33.016 ft-deg	2.820 ft-deg

RTRN010A:
 192' DINNER BOAT

Imaged Compartments:
 STEERING

	DISPLACEMENT LTons	DRAFT AFT ft	DRAFT FWD ft	TRIM ft	HEEL deg.	UPRIGHT Gmt ft
INTACT	417.8	6.410	7.310	0.900F	0.00	12.914
DAMAGED	454.4	7.486	6.597	0.889A	0.00	10.424

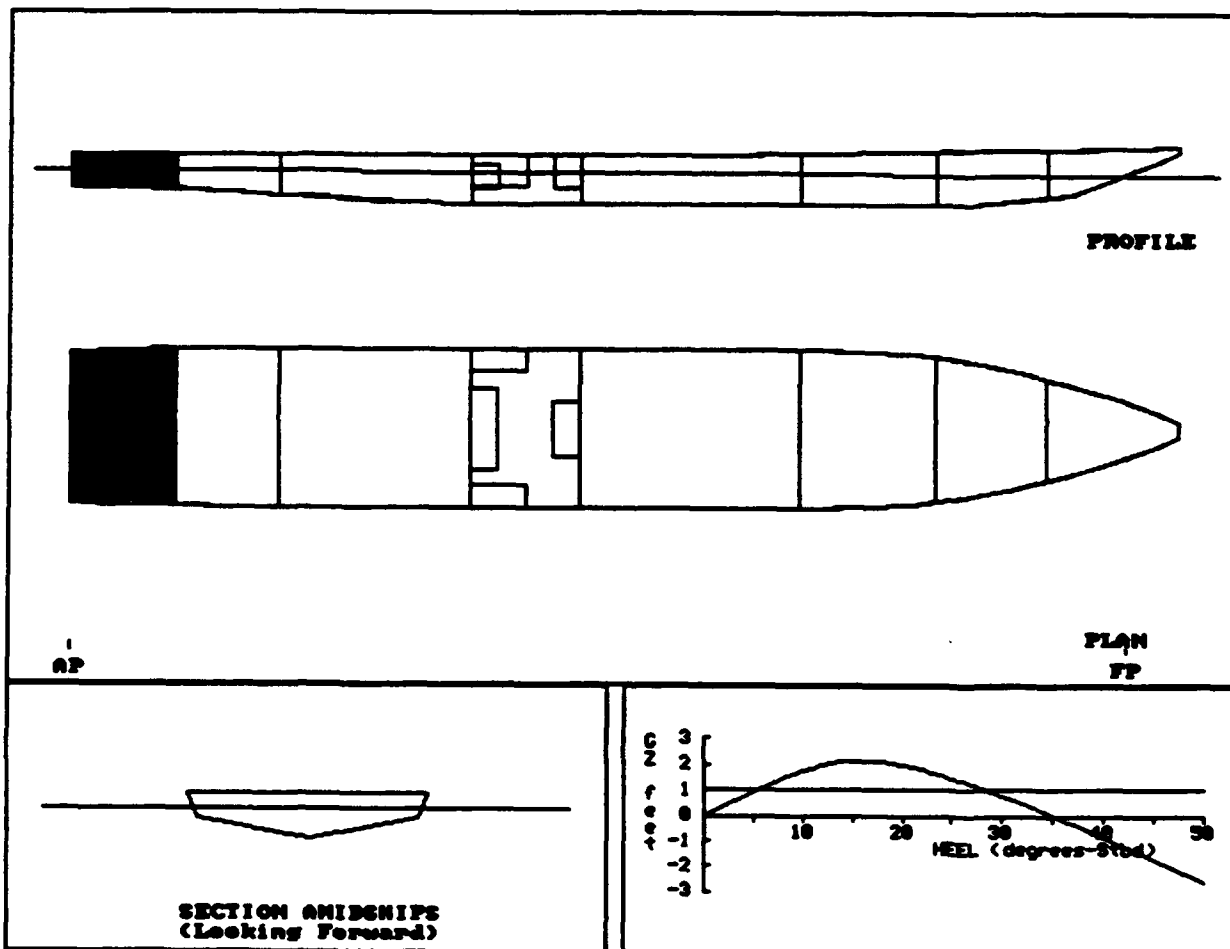

RTRN010A:
 192' DINNER BOAT

COMPARTMENT FLOODING SUMMARY

At 0.0o Heel	PERM.	FLOODED WTR LTons	% FULL (Damaged)	% FULL (Intact)	SP.VOL. ft3/LT	OUTFLOW LTons
STEERING	0.95	36.6	FREE	0.0	----	----
Totals		36.6				

INTACT DATA

Draft at AP = 6.410 ft	KMt = 28.904 ft	LCG = 80.580A ft-FP
Draft at FP = 7.310 ft	VCG = 15.990 ft	LCB = 80.515A ft-FP
Displacement = 417.8 LTons	GMT = 12.914 ft	TCG = 0.000 ft-CL

DRAFT/GZ DATA

HEEL degrees	RIGHTING ARM ft	DRAFT AFT ft	DRAFT FWD ft	FLOODED WATER LTons
0.00	0.000	7.486	6.597	36.6
5.00S	0.911	7.494	6.538	36.9
7.00S	1.269	7.493	6.486	37.0
10.00S	1.727	7.431	6.396	37.1
15.00S	2.136	7.267	6.121	37.6
20.00S	1.974	7.247	5.738	38.5
30.00S	0.798	7.462	4.894	40.3
40.00S	-0.837	7.848	4.000	41.6
50.00S	-2.601	8.478	2.841	42.6

Note: Drafts are measured at A.P. and F.P along ship's centerline

GZ SUMMARY (Evaluated per IMO (SOLAS '90) Rules for Passenger Ships)

	Available	Required
Static Heel Angle	0.00 deg	7.00 deg
Angle at Maximum GZ	17.00S deg	
Maximum GZ	2.146 ft	0.980 ft
Range of Positive GZ	35.06 deg	15.00 deg
Gmt (upright damaged)	10.424 ft	
Righting Area (0.00-%.00)	33.105 ft-deg	2.820 ft-deg

**APPENDIX B
HYDROSTATICS AND
DAMAGE STABILITY
OUTPUT**

183' DINNER BOAT

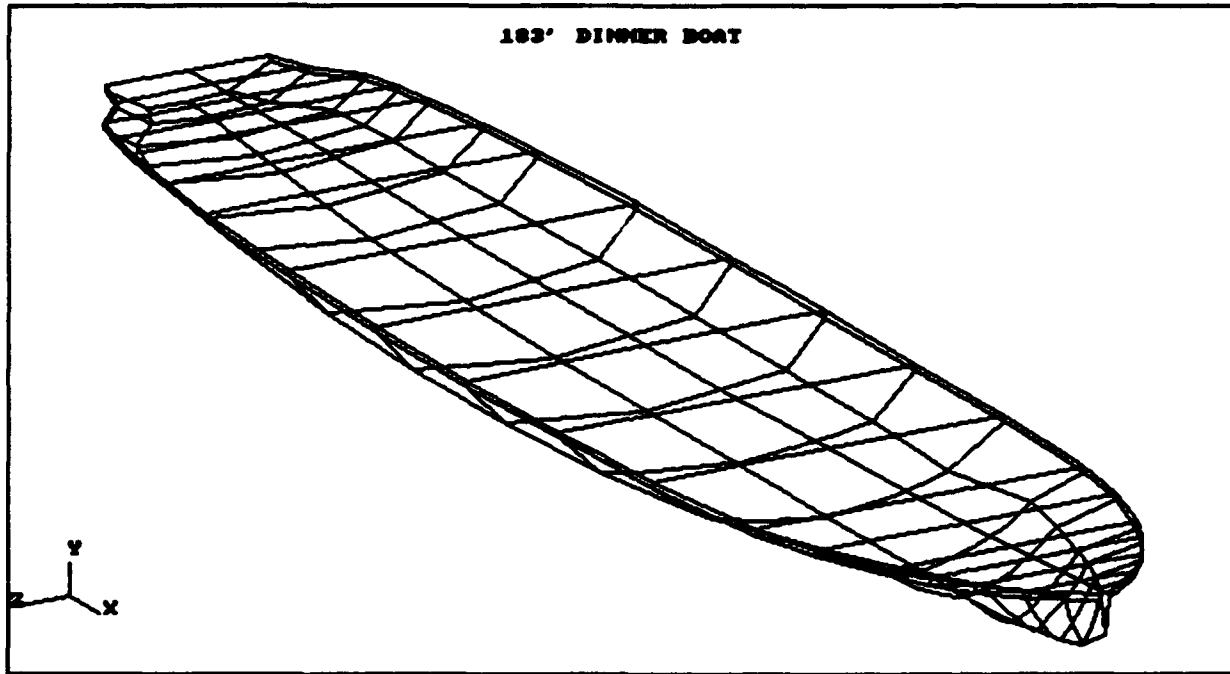

**DAMAGE STABILITY SUMMARY
 183' DINNER BOAT**

CASE No.	FILE NAME	DAMAGED COMP. LISTING	---Intact Condition---			-----Equilibrium Condition After Damage-----					
			MM.DRAFT (ft)	VCG (ft)	GMt (ft)	HEEL (deg)	MAX.GZ (ft)	RANGE (deg)	AREA (ft-deg)	DAM.GMT (ft)	SURVIVAL
1	DPRT001A	1	7.500	16.750	7.419	0.0	1.856	32.92	27.27	7.449	Yes
2	DPRT002A	1,2	7.500	16.750	7.419	0.0	1.689	30.74	25.40	7.540	Yes
3	DPRT003A	2	7.500	16.750	7.419	0.0	1.712	31.37	25.53	7.368	Yes
4	DPRT004A	4	7.500	16.750	7.419	0.0	1.021	24.87	15.43	6.657	Yes
5	DPRT005A	2,3	7.500	16.750	7.419	0.0	1.617	30.30	25.02	7.999	Yes
6	DPRT006A	4,5	7.500	16.750	7.419	0.0	1.014	24.22	15.31	7.543	Yes
7	DPRT007A	6	7.500	16.750	7.419	0.0	1.398	29.39	21.24	6.495	Yes
8	DPRT008A	8	7.500	16.750	7.419	0.0	0.975	24.02	14.01	5.754	Yes
9	DPRT009A	10	7.500	16.750	7.419	0.0	0.785	21.19	10.38	6.021	Yes
10	DPRT010A	11	7.500	16.750	7.419	0.0	1.396	29.11	20.95	6.267	Yes
11	DPRT011A	11,12	7.500	16.750	7.419	0.0	1.274	27.25	19.27	6.575	Yes

DPR001A:
 183' DINNER BOAT

Damaged Compartments:
 FOREPEAK

	DISPLACEMENT LTons	DRAFT AFT ft	DRAFT FWD ft	TRIM ft	HEEL deg.	UPRIGHT Gmt ft
INTACT	715.8	7.500	7.500	0.000	0.00	7.419
DAMAGED	723.7	7.346	7.798	0.451F	0.00	7.449

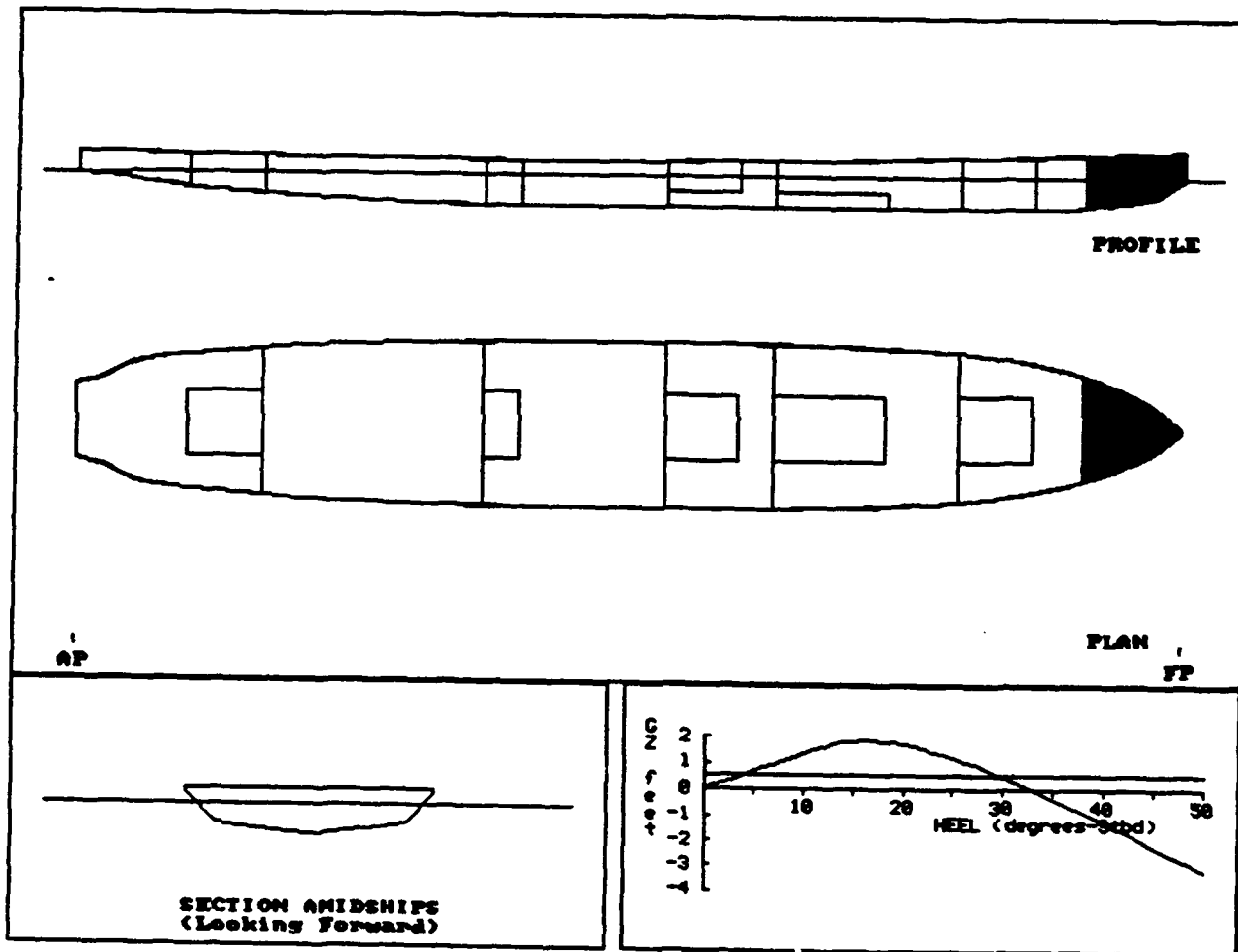

**DPRT001A:
 183' DINNER BOAT**

COMPARTMENT FLOODING SUMMARY

At 0.0o Heel	PERM.	FLOODED WTR LTons	% FULL (Damaged)	% FULL (Intact)	SP.VOL. ft3/LT	OUTFLOW LTons
FOREPEAK	0.95	7.9	FREE	0.0	----	----
Totals		7.9				

INTACT DATA

Draft at AP = 7.500 ft	KMT = 24.169 ft	LCG = 91.829A ft-FP
Draft at FP = 7.500 ft	VCG = 16.750 ft	LCB = 91.829A ft-FP
Displacement = 715.8 LTons	GMT = 7.419 ft	TCG = 0.000 ft-CL

DRAFT/GZ DATA

HEEL degrees	RIGHTING ARM ft	DRAFT AFT ft	DRAFT FWD ft	FLOODED WATER LTons
0.00	0.000	7.346	7.798	7.9
5.00S	0.660	7.299	7.750	7.8
7.00S	0.936	7.255	7.702	7.7
10.00S	1.363	7.165	7.593	7.5
15.00S	1.831	6.998	7.432	7.2
20.00S	1.728	6.862	7.414	7.3
30.00S	0.487	6.606	7.573	8.9
40.00S	-1.276	6.292	8.005	11.7
50.00S	-3.184	5.868	8.742	14.5

Note: Drafts are measured at A.P. and F.P along ship's centerline

GZ SUMMARY (Evaluated per IMO (SOLAS'90) Rules for Passenger Ships)

	Available	Required
Static Heel Angle	0.00 deg	7.00 deg
Angle at Maximum GZ	17.00S deg	
Maximum GZ	1.856 ft	0.560 ft
Range of Positive GZ	32.92 deg	15.00 deg
Gmt (upright damaged)	7.449 ft	
Righting Area (0.00-3.00)	27.274 ft-deg	2.820 ft-deg

DPRT002A:
 183' DINNER BOAT

Damaged Compartments:
 FOREPEAK BOW THRUSTER

	DISPLACEMENT LTons	DRAFT AFT ft	DRAFT FWD ft	TRIM ft	HEEL deg.	UPRIGHT GMT ft
INTACT	715.8	7.500	7.500	0.000	0.00	7.419
DAMAGED	746.0	6.970	8.547	1.577F	0.00	7.540

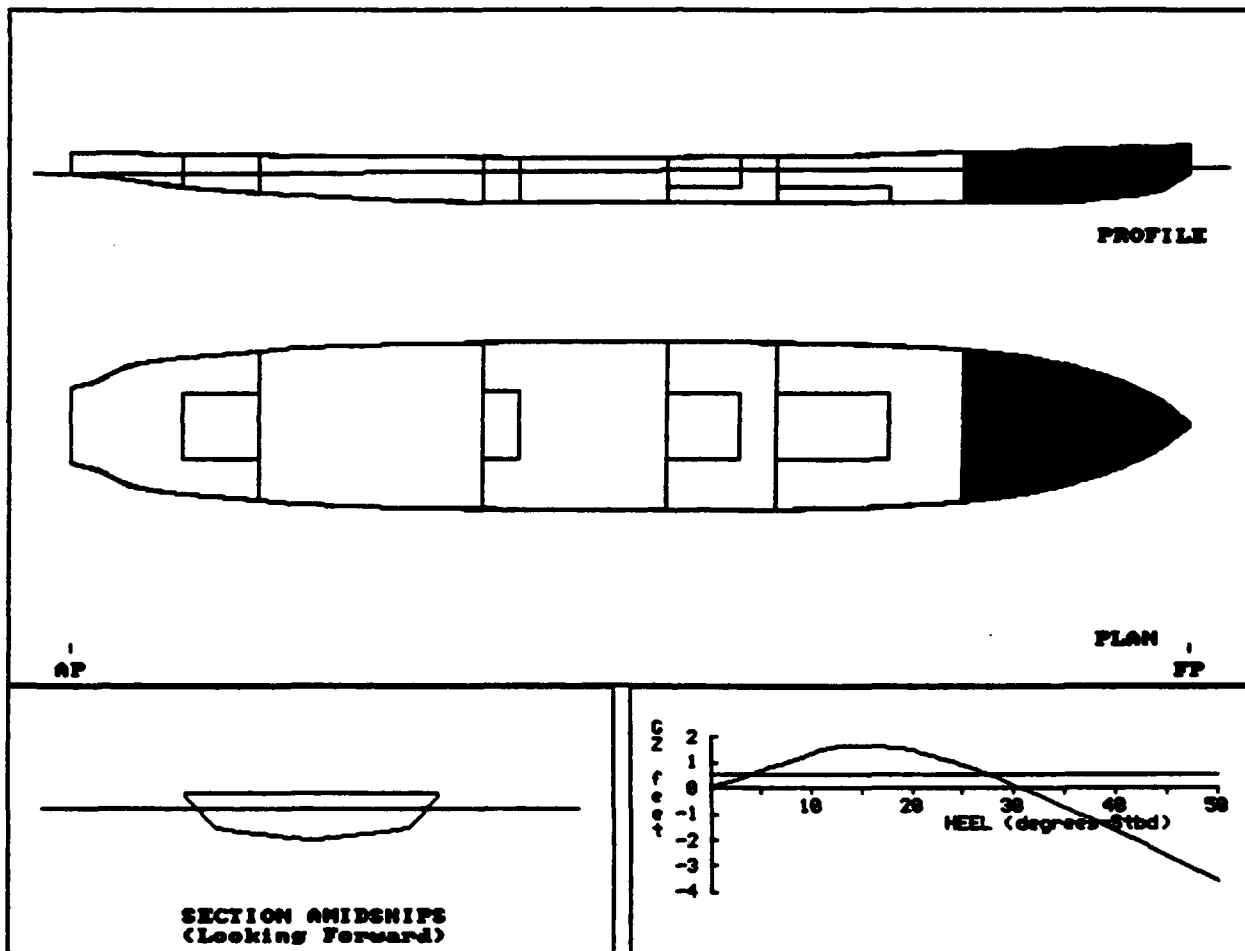

**DPRT002A:
 183' DINNER BOAT**

COMPARTMENT FLOODING SUMMARY

At 0.0o Heel	PERM.	FLOODED WTR LTons	% FULL (Damaged)	% FULL (Intact)	SP.VOL. ft3/LT	OUTFLOW LTons
FOREPEAK	0.95	9.6	FREE	0.0	----	----
BOW THRUSTER	0.95	20.6	FREE	0.0	----	----
Totals		30.2				

INTACT DATA

Draft at AP = 7.500 ft KMT = 24.169 ft LCG = 91.829A ft-FP
 Draft at FP = 7.500 ft VCG = 16.750 ft LCB = 91.829A ft-FP
 Displacement = 715.8 LTons GMT = 7.419 ft TCG = 0.000 ft-CL

DRAFT/GZ DATA

HEEL degrees	RIGHTING ARM ft	DRAFT AFT ft	DRAFT FWD ft	FLOODED WATER LTons
0.00	0.000	6.970	8.547	30.2
5.00S	0.666	6.921	8.502	30.4
7.00S	0.944	6.875	8.455	30.6
10.00S	1.362	6.770	8.369	31.3
15.00S	1.689	6.514	8.431	35.6
20.00S	1.466	6.213	8.788	41.8
30.00S	0.125	5.518	9.864	51.0
40.00S	-1.657	4.667	11.378	57.8
50.00S	-3.553	3.514	13.582	62.8

Note: Drafts are measured at A.P. and F.P along ship's centerline

GZ SUMMARY (Evaluated per IMO (SOLAS'90) Rules for Passenger Ships)

	Available	Required
Static Heel Angle	0.00 deg	7.00 deg
Angle at Maximum GZ	16.00S deg	
Maximum GZ	1.689 ft	0.560 ft
Range of Positive GZ	30.74 deg	15.00 deg
Gmt (upright damaged)	7.540 ft	
Righting Area (0.00-%.00)	25.405 ft-deg	2.820 ft-deg

DPR003A:
 183' DINNER BOAT

Damaged Compartments:
 BOW THRUSTER

	DISPLACEMENT LTons	DRAFT AFT ft	DRAFT FWD ft	TRIM ft	HEEL deg.	UPRIGHT GMT ft
INTACT	715.8	7.500	7.500	0.000	0.00	7.419
DAMAGED	734.7	7.193	8.132	0.939F	0.00	7.368

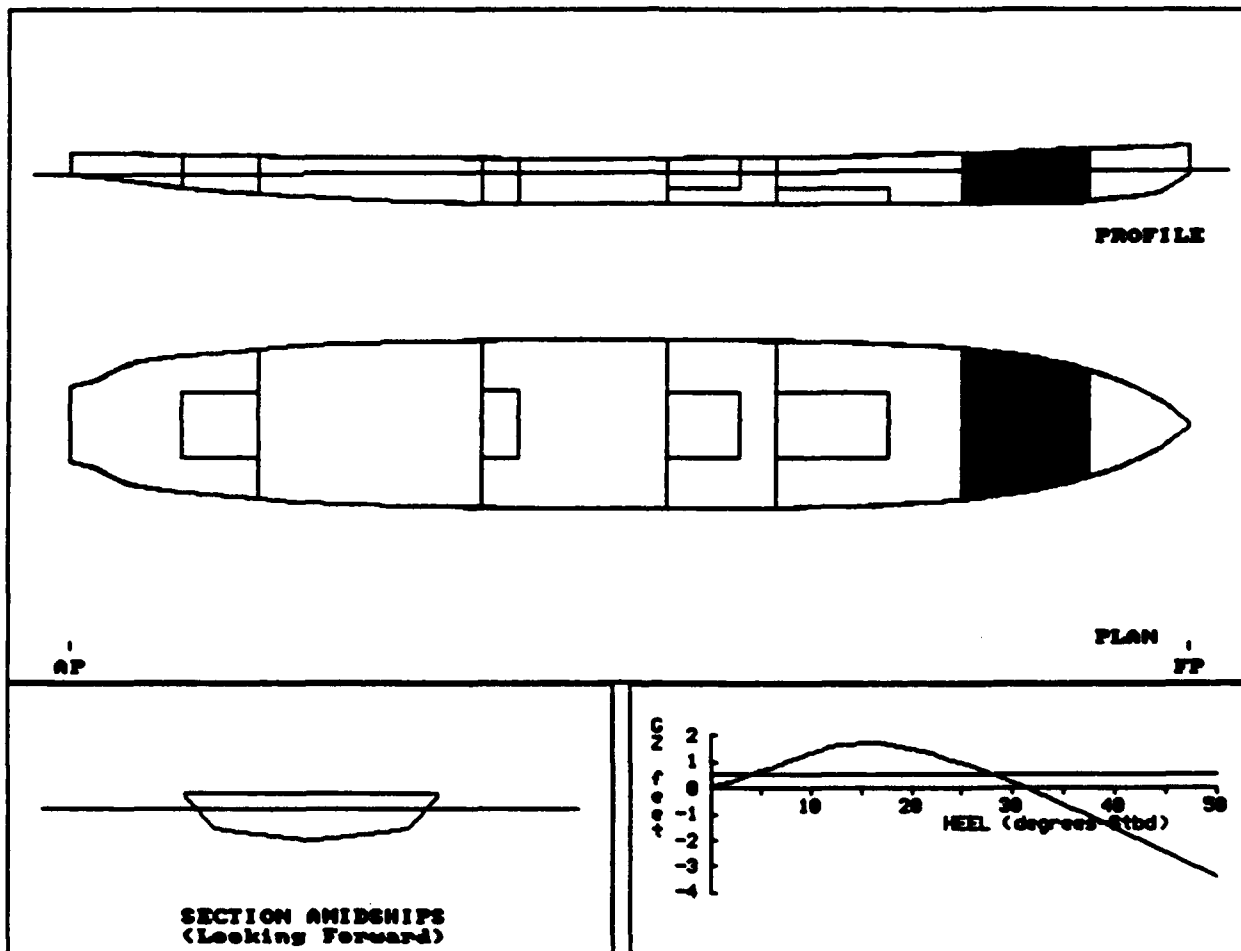

DFRT003A:
 183' DINNER BOAT

COMPARTMENT FLOODING SUMMARY

At 0.0o Heel	PERM.	FLOODED WTR LTons	% FULL (Damaged)	% FULL (Intact)	SP.VOL. ft3/LT	OUTFLOW LTons
BOW THRUSTER	0.95	18.9	FREE	0.0	----	----
Totals		18.9				

INTACT DATA

Draft at AP = 7.500 ft KMT = 24.169 ft LCG = 91.829A ft-FP
 Draft at FP = 7.500 ft VCG = 16.750 ft LCB = 91.829A ft-FP
 Displacement = 715.8 LTons GMT = 7.419 ft TCG = 0.000 ft-CL

DRAFT/GZ DATA

HEEL degrees	RIGHTING ARM ft	DRAFT AFT ft	DRAFT FWD ft	FLOODED WATER LTons
0.00	0.000	7.193	8.132	18.9
5.00S	0.652	7.143	8.091	19.1
7.00S	0.924	7.095	8.050	19.3
10.00S	1.340	6.991	7.966	20.0
15.00S	1.711	6.760	7.962	23.4
20.00S	1.508	6.511	8.208	28.5
30.00S	0.224	6.113	8.728	32.7
40.00S	-1.521	5.654	9.482	34.5
50.00S	-3.393	5.151	10.493	35.6

Note: Drafts are measured at A.P. and F.P along ship's centerline

GZ SUMMARY (Evaluated per IMO (SOLAS'90) Rules for Passenger Ships)

	Available	Required
Static Heel Angle	0.00 deg	7.00 deg
Angle at Maximum GZ	17.00S deg	
Maximum GZ	1.712 ft	0.560 ft
Range of Positive GZ	31.37 deg	15.00 deg
Gmt (upright damaged)	7.368 ft	
Righting Area (0.00-%.00)	25.526 ft-deg	2.820 ft-deg

DPRT004A:
 183' DINNER BOAT

Damaged Compartments:
 GALLEY STORS

	DISPLACEMENT LTONS	DRAFT AFT ft	DRAFT FWD ft	TRIM ft	HEEL deg.	UPRIGHT CNT ft
INTACT	715.8	7.500	7.500	0.000	0.00	7.419
DAMAGED	887.5	6.295	11.185	4.890F	0.00	6.657

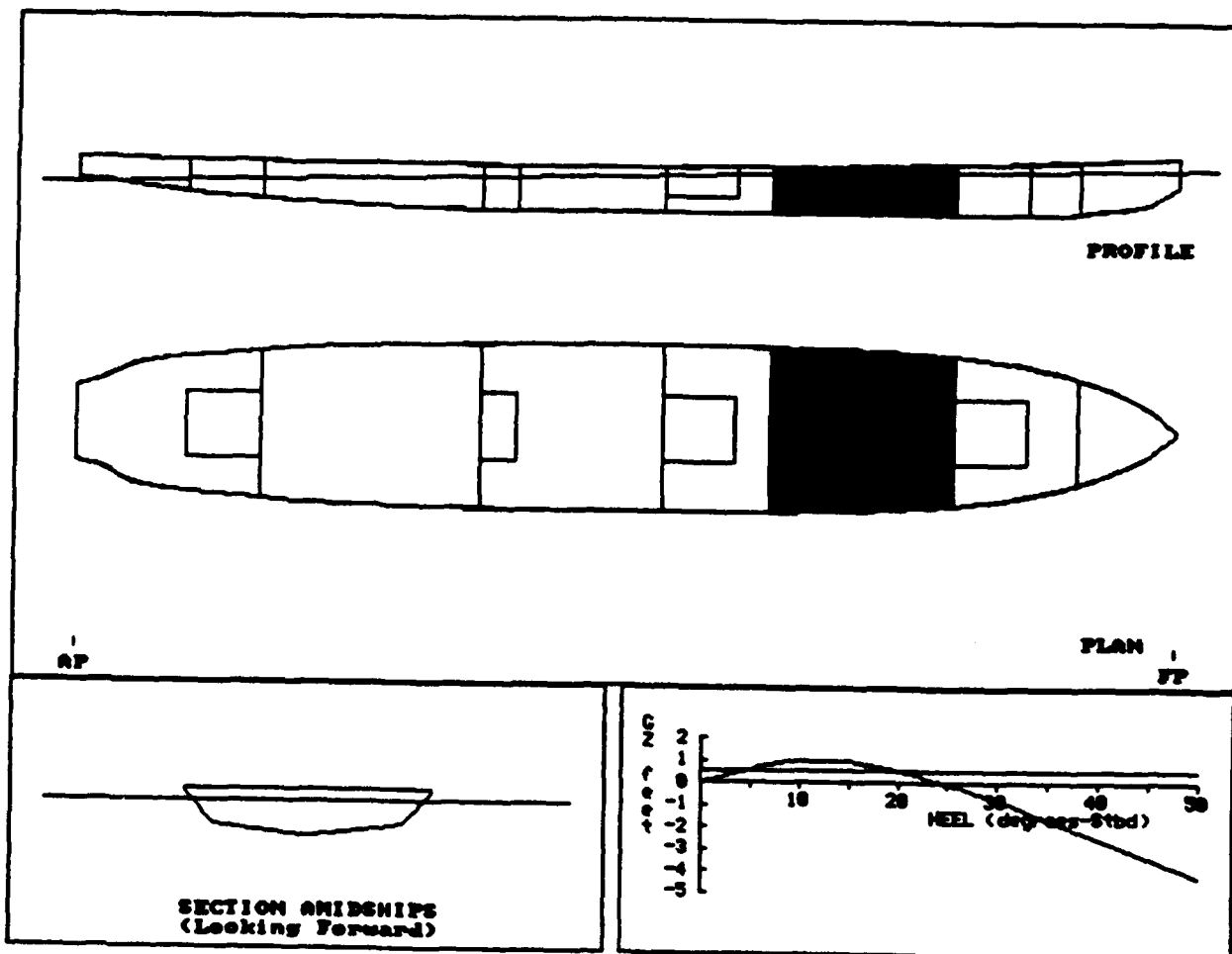

DPRT004A:
 183' DINNER BOAT

COMPARTMENT FLOODING SUMMARY

At 0.0o Heel	PERM.	FLOODED WTR LTons	% FULL (Damaged)	% FULL (Intact)	SP.VOL. ft3/LT	OUTFLOW LTons
GALLEY STORS	0.95	171.8	FREE	0.0	----	----
Totals		171.8				

INTACT DATA

Draft at AP = 7.500 ft KMt = 24.169 ft LCG = 91.829A ft-FP
 Draft at FP = 7.500 ft VCG = 16.750 ft LCB = 91.829A ft-FP
 Displacement = 715.8 LTons GMT = 7.419 ft TCG = 0.000 ft-CL

DRAFT/GZ DATA

HEEL degrees	RIGHTING ARM ft	DRAFT AFT ft	DRAFT FWD ft	FLOODED WATER LTons
0.00	0.000	6.295	11.185	171.8
5.00S	0.583	6.246	11.121	171.9
7.00S	0.796	6.210	11.065	171.3
10.00S	0.989	6.112	11.082	169.1
15.00S	0.945	5.924	11.363	166.3
20.00S	0.580	5.671	11.963	165.1
30.00S	-0.768	5.119	13.702	163.8
40.00S	-2.468	4.326	16.230	163.4
50.00S	-4.227	3.280	19.756	163.0

Note: Drafts are measured at A.P. and F.P along ship's centerline

GZ SUMMARY (Evaluated per IMO (SOLAS'90) Rules for Passenger Ships)

	Available	Required
Static Heel Angle	0.00 deg	7.00 deg
Angle at Maximum GZ	13.00S deg	
Maximum GZ	1.021 ft	0.560 ft
Range of Positive GZ	24.87 deg	15.00 deg
Gmt (upright damaged)	6.657 ft	
Righting Area (0.00-%.00)	15.430 ft-deg	2.820 ft-deg

DPRT005A:
 183' DINNER BOAT

Damaged Compartments:
 BOW THRUSTER FWD BALLAST

	DISPLACEMENT LTons	DRAFT AFT ft	DRAFT FWD ft	TRIM ft	HEEL deg.	UPRIGHT Gmt ft
INTACT	715.8	7.500	7.500	0.000	0.00	7.419
DAMAGED	776.8	6.572	9.419	2.847F	0.00	7.999

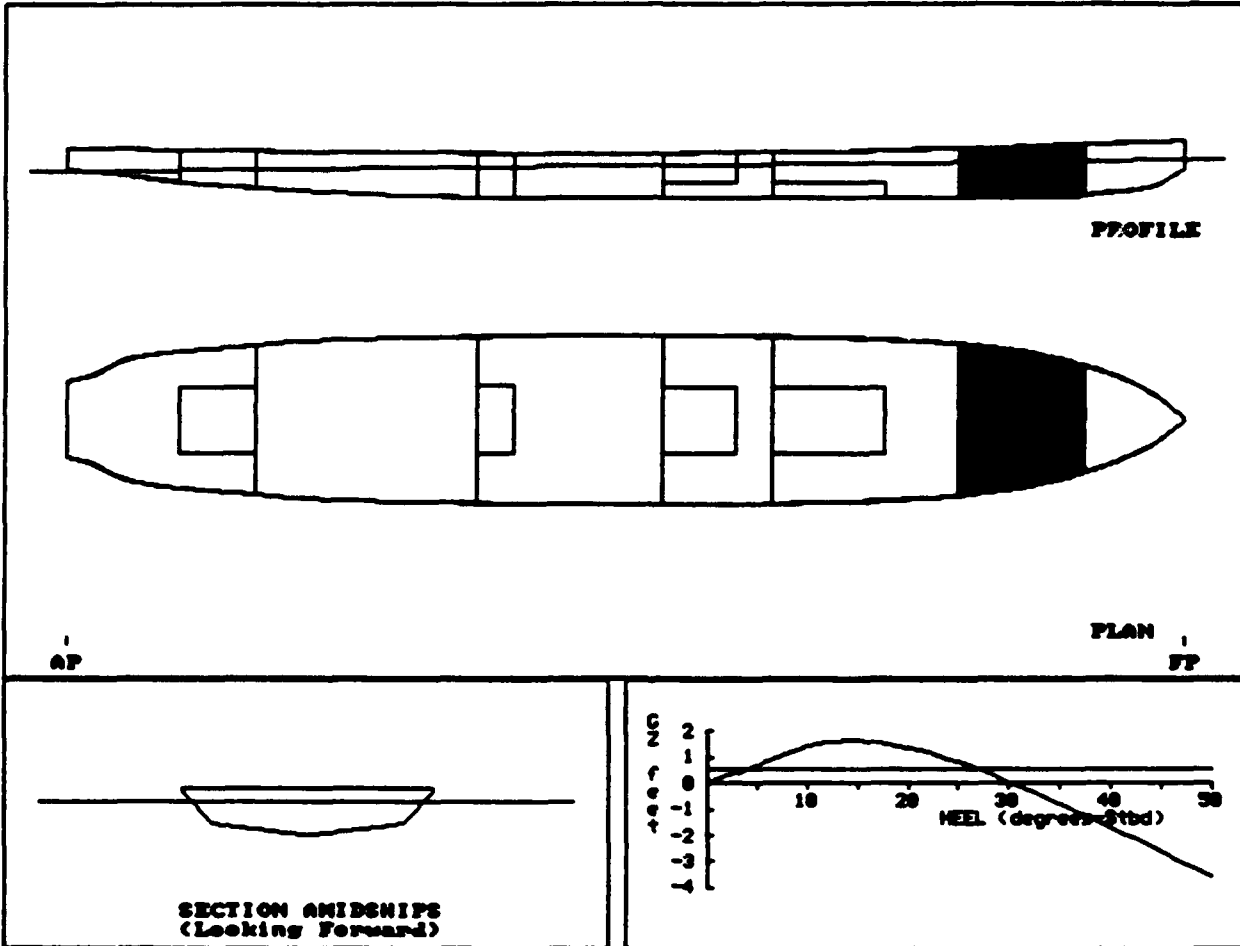

DPRT005A:
 183' DINNER BOAT

COMPARTMENT FLOODING SUMMARY

At 0.0o Heel	PERM.	FLOODED WTR LTons	% FULL (Damaged)	% FULL (Intact)	SP.VOL. ft3/LT	OUTFLOW LTons
BOW THRUSTER	0.95	24.7	FREE	0.0	----	----
FWD BALLAST	0.95	36.4	FREE	0.0	----	----
Totals		61.1				

INTACT DATA

Draft at AP = 7.500 ft KMT = 24.169 ft LCG = 91.829A ft-FP
 Draft at FP = 7.500 ft VCG = 16.750 ft LCB = 91.829A ft-FP
 Displacement = 715.8 LTons GMT = 7.419 ft TCG = 0.000 ft-CL

DRAFT/GZ DATA

HEEL degrees	RIGHTING ARM ft	DRAFT AFT ft	DRAFT FWD ft	FLOODED WATER LTons
0.00	0.000	6.572	9.419	61.1
5.00S	0.705	6.521	9.368	61.4
7.00S	0.995	6.476	9.315	61.7
10.00S	1.401	6.370	9.245	62.8
15.00S	1.616	6.081	9.449	68.3
20.00S	1.370	5.767	9.896	73.3
30.00S	0.049	5.033	11.196	79.6
40.00S	-1.700	4.157	12.944	83.4
50.00S	-3.565	2.908	15.552	86.3

Note: Drafts are measured at A.P. and F.P along ship's centerline

GZ SUMMARY (Evaluated per IMO (SOLAS'90) Rules for Passenger Ships)

	Available	Required
Static Heel Angle	0.00 deg	7.00 deg
Angle at Maximum GZ	15.00S deg	
Maximum GZ	1.617 ft	0.560 ft
Range of Positive GZ	30.30 deg	15.00 deg
Gmt (upright damaged)	7.999 ft	
Righting Area (0.00-7.00)	25.018 ft-deg	2.820 ft-deg

DPRT006A:
 183' DINNER BOAT

Damaged Compartments:

GALLEY STORS SEWAGE TANK

	DISPLACEMENT LTONS	DRAFT AFT ft	DRAFT FWD ft	TRIM ft	HEEL deg.	UPRIGHT GMT ft
INTACT	715.8	7.500	7.500	0.000	0.00	7.419
DAMAGED	922.6	6.137	11.783	5.647F	0.00	7.543

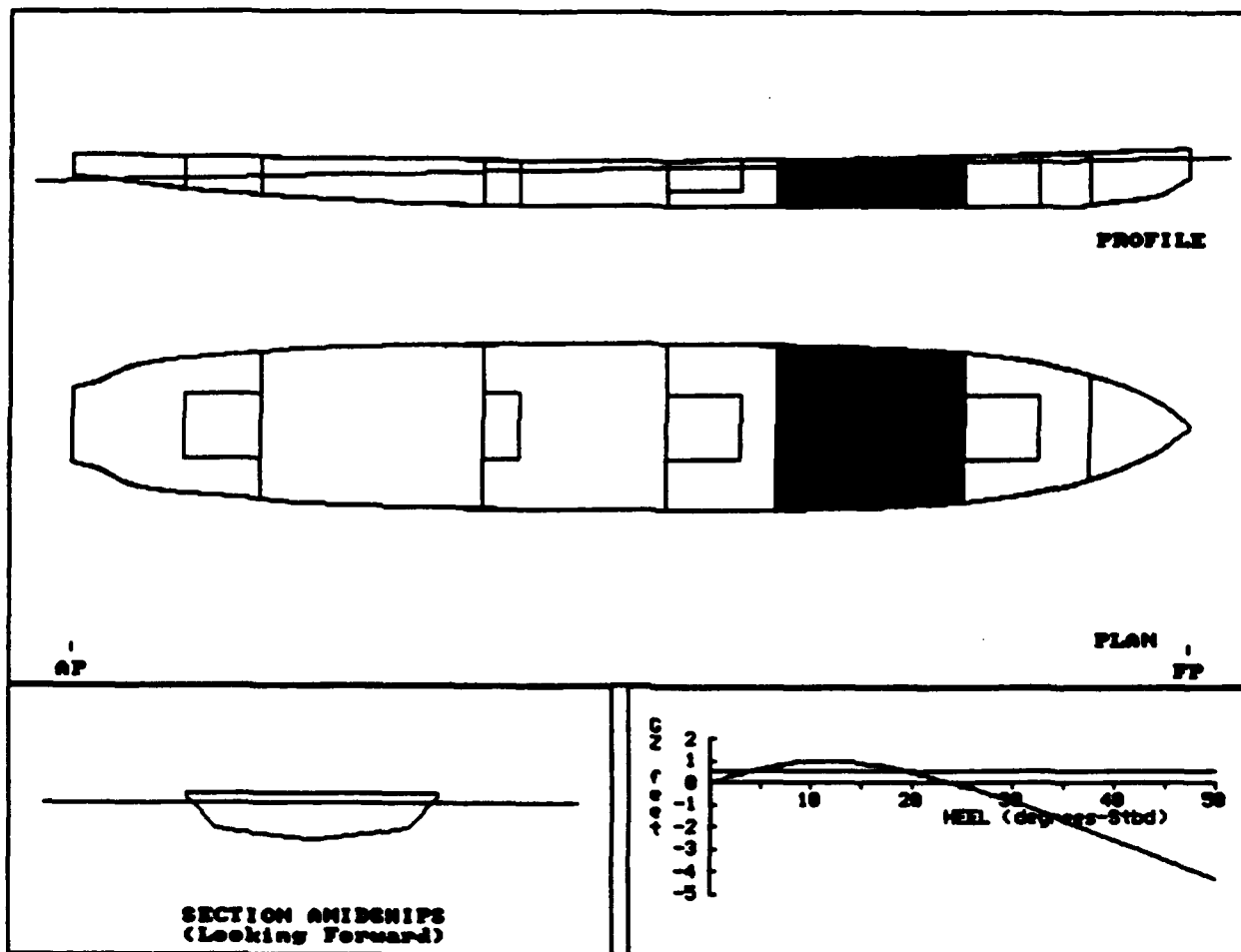

DPRT006A:
 183' DINNER BOAT

COMPARTMENT FLOODING SUMMARY

At 0.0o Heel	PERM.	FLOODED WTR LTons	% FULL (Damaged)	% FULL (Intact)	SP.VOL. ft3/LT	OUTFLOW LTons
GALLEY STORS	0.95	183.5	FREE	0.0	----	----
SEWAGE TANK	0.95	25.9	FREE	10.0	35.0063	2.6
Totals		209.4				2.6

INTACT DATA

Draft at AP = 7.500 ft Kmt = 24.169 ft LCG = 91.829A ft-FP
 Draft at FP = 7.500 ft VCG = 16.750 ft LCB = 91.829A ft-FP
 Displacement = 715.8 LTons GMT = 7.419 ft TCG = 0.000 ft-CL

DRAFT/GZ DATA

HEEL degrees	RIGHTING ARM ft	DRAFT AFT ft	DRAFT FWD ft	FLOODED WATER LTons
0.00	0.000	6.137	11.783	209.4
5.00S	0.647	6.085	11.727	209.2
7.00S	0.850	6.044	11.706	207.5
10.00S	1.002	5.926	11.818	204.9
15.00S	0.905	5.680	12.296	202.2
20.00S	0.506	5.373	13.111	201.2
30.00S	-0.857	4.610	15.519	201.4
40.00S	-2.537	3.585	18.869	202.0
50.00S	-4.273	2.122	23.689	202.8

Note: Drafts are measured at A.P. and F.P along ship's centerline

GZ SUMMARY (Evaluated per IMO (SOLAS'90) Rules for Passenger Ships)
 Available Required

Static Heel Angle	0.00 deg	7.00 deg
Angle at Maximum GZ	12.00S deg	
Maximum GZ	1.014 ft	0.560 ft
Range of Positive GZ	24.22 deg	15.00 deg
Gmt (upright damaged)	7.543 ft	
Righting Area (0.00-7.00)	15.307 ft-deg	2.820 ft-deg

DPRT007A:
 183' DINNER BOAT

Damaged Compartments:

FWD MACHY RM

	DISPLACEMENT LTons	DRAFT AFT ft	DRAFT FWD ft	TRIM ft	HEEL deg.	UPRIGHT GMT ft
INTACT	715.8	7.500	7.500	0.000	0.00	7.419
DAMAGED	800.6	7.481	8.735	1.254F	0.00	6.495

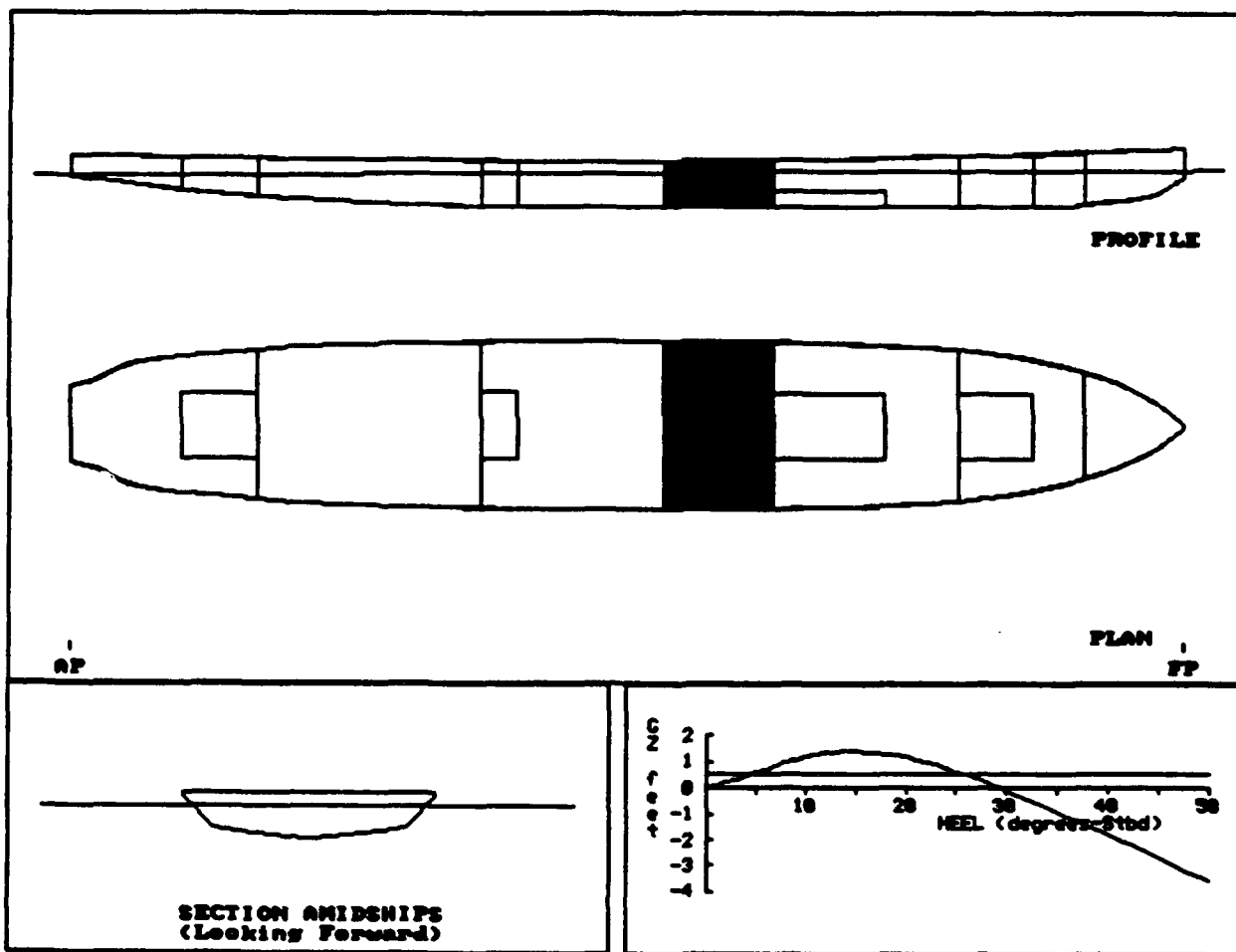

DPRT007A:
 183' DINNER BOAT

COMPARTMENT FLOODING SUMMARY

At 0.0o Heel	PERM.	FLOODED WTR LTons	% FULL (Damaged)	% FULL (Intact)	SP.VOL. ft3/LT	OUTFLOW LTons
FWD MACHY RM	0.85	84.8	FREE	0.0	----	----
Totals		84.8				

INTACT DATA

Draft at AP = 7.500 ft	KMT = 24.169 ft	LCG = 91.829A ft-FP
Draft at FP = 7.500 ft	VCG = 16.750 ft	LCB = 91.829A ft-FP
Displacement = 715.8 LTons	GMT = 7.419 ft	TCG = 0.000 ft-CL

DRAFT/GZ DATA

HEEL degrees	RIGHTING ARM ft	DRAFT AFT ft	DRAFT FWD ft	FLOODED WATER LTons
0.00	0.000	7.481	8.735	84.8
5.00S	0.579	7.442	8.676	84.9
7.00S	0.824	7.405	8.619	85.1
10.00S	1.181	7.325	8.513	85.0
15.00S	1.398	7.214	8.442	83.0
20.00S	1.169	7.173	8.514	80.3
30.00S	-0.095	7.175	8.825	76.2
40.00S	-1.791	7.247	9.334	73.5
50.00S	-3.591	7.415	10.076	71.6

Note: Drafts are measured at A.P. and F.P along ship's centerline

GZ SUMMARY (Evaluated per IMO (SOLAS'90) Rules for Passenger Ships)

	Available	Required
Static Heel Angle	0.00 deg	7.00 deg
Angle at Maximum GZ	16.00S deg	
Maximum GZ	1.398 ft	0.560 ft
Range of Positive GZ	29.39 deg	15.00 deg
Gmt (upright damaged)	6.495 ft	
Righting Area (0.00-7.00)	21.242 ft-deg	2.820 ft-deg

DPR008A:
 183' DINNER BOAT

Damaged Compartments:
 VOID

	DISPLACEMENT LTons	DRAFT AFT ft	DRAFT FWD ft	TRIM ft	HEEL deg.	UPRIGHT GMT ft
INTACT	715.8	7.500	7.500	0.000	0.00	7.419
DAMAGED	909.5	8.779	8.734	0.044A	0.00	5.754

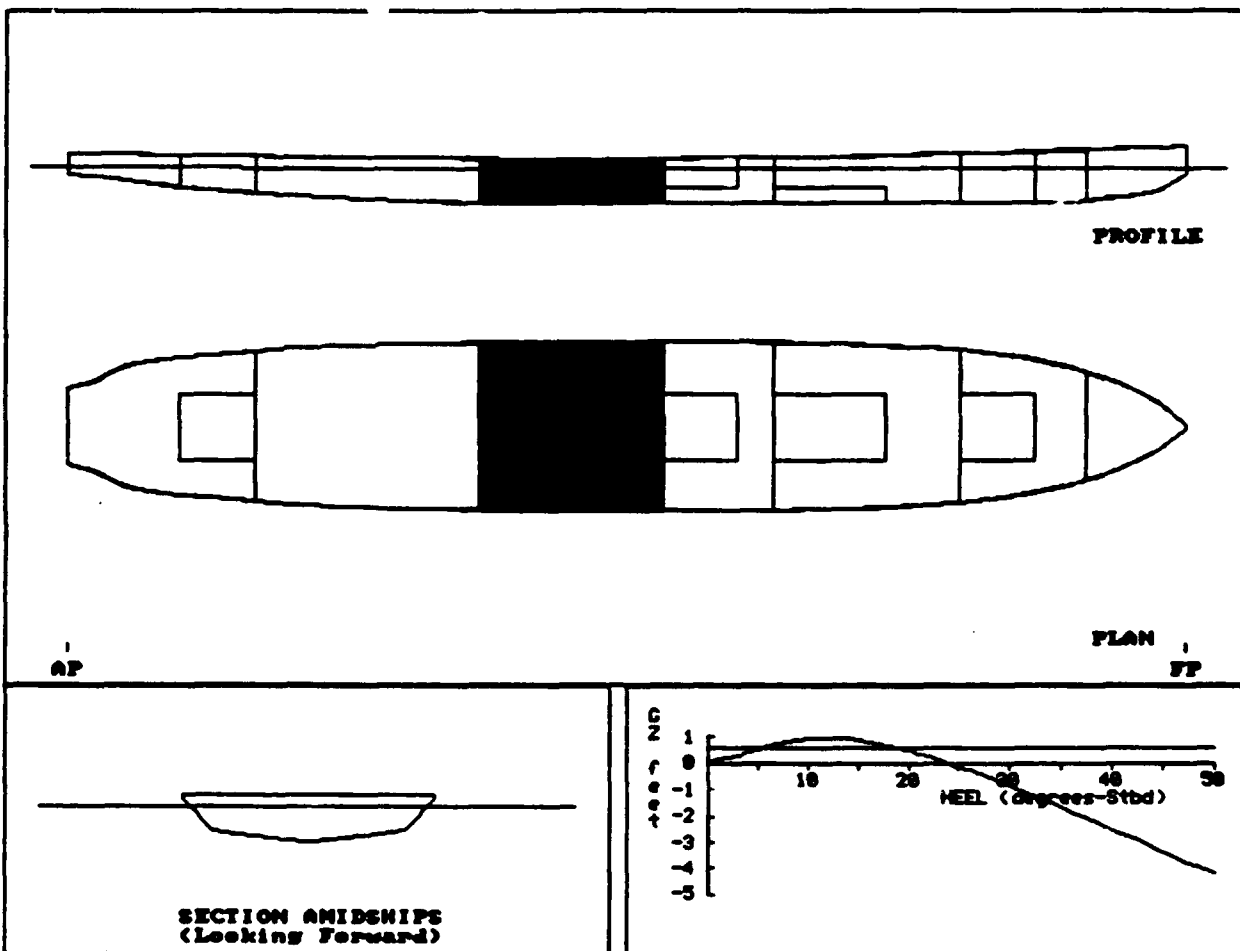

**DPRT008A:
 183' DINNER BOAT**

COMPARTMENT FLOODING SUMMARY

At 0.0o Heel	PERM.	FLOODED WTR LTons	% FULL (Damaged)	% FULL (Intact)	SP.VOL. ft3/LT	OUTFLOW LTons
VOID	0.95	193.7	FREE	0.0	----	----
Totals		193.7				

INTACT DATA

Draft at AP = 7.500 ft	KMt = 24.169 ft	LCG = 91.829A ft-FP
Draft at FP = 7.500 ft	VCG = 16.750 ft	LCB = 91.829A ft-FP
Displacement = 715.8 LTons	GMT = 7.419 ft	TCG = 0.000 ft-CL

DRAFT/GZ DATA

HEEL degrees	RIGHTING ARM ft	DRAFT AFT ft	DRAFT FWD ft	FLOODED WATER LTons
0.00	0.000	8.779	8.734	193.7
5.00S	0.515	8.748	8.660	193.5
7.00S	0.726	8.716	8.597	193.2
10.00S	0.943	8.687	8.506	190.6
15.00S	0.878	8.770	8.460	184.7
20.00S	0.474	9.005	8.521	178.9
30.00S	-0.867	9.810	8.763	170.4
40.00S	-2.519	10.893	9.204	165.7
50.00S	-4.216	12.437	9.861	162.7

Note: Drafts are measured at A.P. and F.P along ship's centerline

GZ SUMMARY (Evaluated per IMO (SOLAS'90) Rules for Passenger Ships)

	Available	Required
Static Heel Angle	0.00 deg	7.00 deg
Angle at Maximum GZ	13.00S deg	
Maximum GZ	0.975 ft	0.560 ft
Range of Positive GZ	24.02 deg	15.00 deg
Gmt (upright damaged)	5.754 ft	
Righting Area (0.00-%.00)	14.009 ft-deg	2.820 ft-deg

DPRT009A:
 183' DINNER BOAT

Damaged Compartments:
 ENGINE ROOM

	DISPLACEMENT LTons	DRAFT AFT ft	DRAFT FWD ft	TRIM ft	HEEL deg.	UPRIGHT GMT ft
INTACT	715.8	7.500	7.500	0.000	0.00	7.419
DAMAGED	936.1	11.013	6.390	4.623A	0.00	6.021

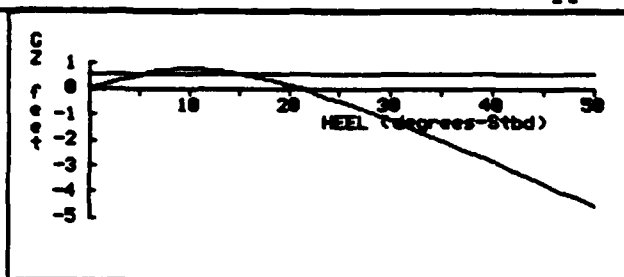
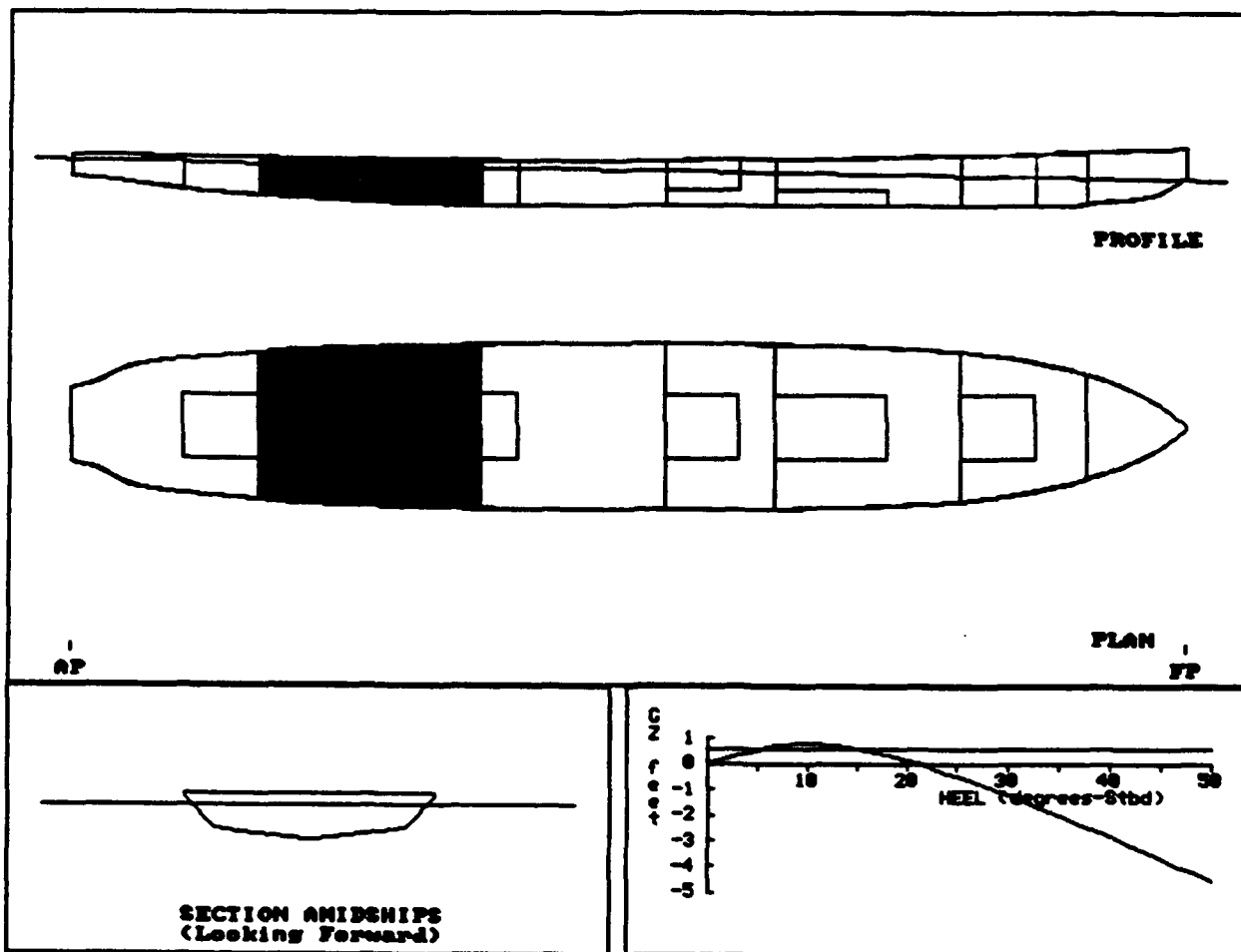

DPRT009A:
 183' DINNER BOAT

COMPARTMENT FLOODING SUMMARY

At 0.0o Heel	PERM.	FLOODED WTR LTons	% FULL (Damaged)	% FULL (Intact)	SP.VOL. ft3/LT	OUTFLOW LTons
ENGINE ROOM	0.85	220.3	FREE	0.0	----	----
Totals		220.3				

INTACT DATA

Draft at AP = 7.500 ft KMT = 24.169 ft LCG = 91.829A ft-FP
 Draft at FP = 7.500 ft VCG = 16.750 ft LCB = 91.829A ft-FP
 Displacement = 715.8 LTons GMT = 7.419 ft TCG = 0.000 ft-CL

DRAFT/GZ DATA

HEEL degrees	RIGHTING ARM ft	DRAFT AFT ft	DRAFT FWD ft	FLOODED WATER LTons
0.00	0.000	11.013	6.390	220.3
5.00S	0.525	10.971	6.345	220.0
7.00S	0.694	10.978	6.288	218.7
10.00S	0.785	11.131	6.148	216.3
15.00S	0.592	11.747	5.813	214.0
20.00S	0.137	12.657	5.451	212.8
30.00S	-1.234	15.106	4.725	211.7
40.00S	-2.863	18.351	3.873	210.8
50.00S	-4.527	22.821	2.776	210.3

Note: Drafts are measured at A.P. and F.P along ship's centerline

GZ SUMMARY (Evaluated per IMO (SOLAS'90) Rules for Passenger Ships)
 Available Required

Static Heel Angle	0.00 deg	7.00 deg
Angle at Maximum GZ	11.00S deg	
Maximum GZ	0.785 ft	0.560 ft
Range of Positive GZ	21.19 deg	15.00 deg
Gmt (upright damaged)	6.021 ft	
Righting Area (0.00-3.19)	10.384 ft-deg	2.820 ft-deg

DPERT010A:
 183' DINNER BOAT

Damaged Compartments:
 LAZARETTE

	DISPLACEMENT LTons	DRAFT AFT ft	DRAFT FWD ft	TRIM ft	HEEL deg.	UPRIGHT GMT ft
INTACT	715.8	7.500	7.500	0.000	0.00	7.419
DAMAGED	754.2	8.517	6.846	1.671A	0.00	6.267

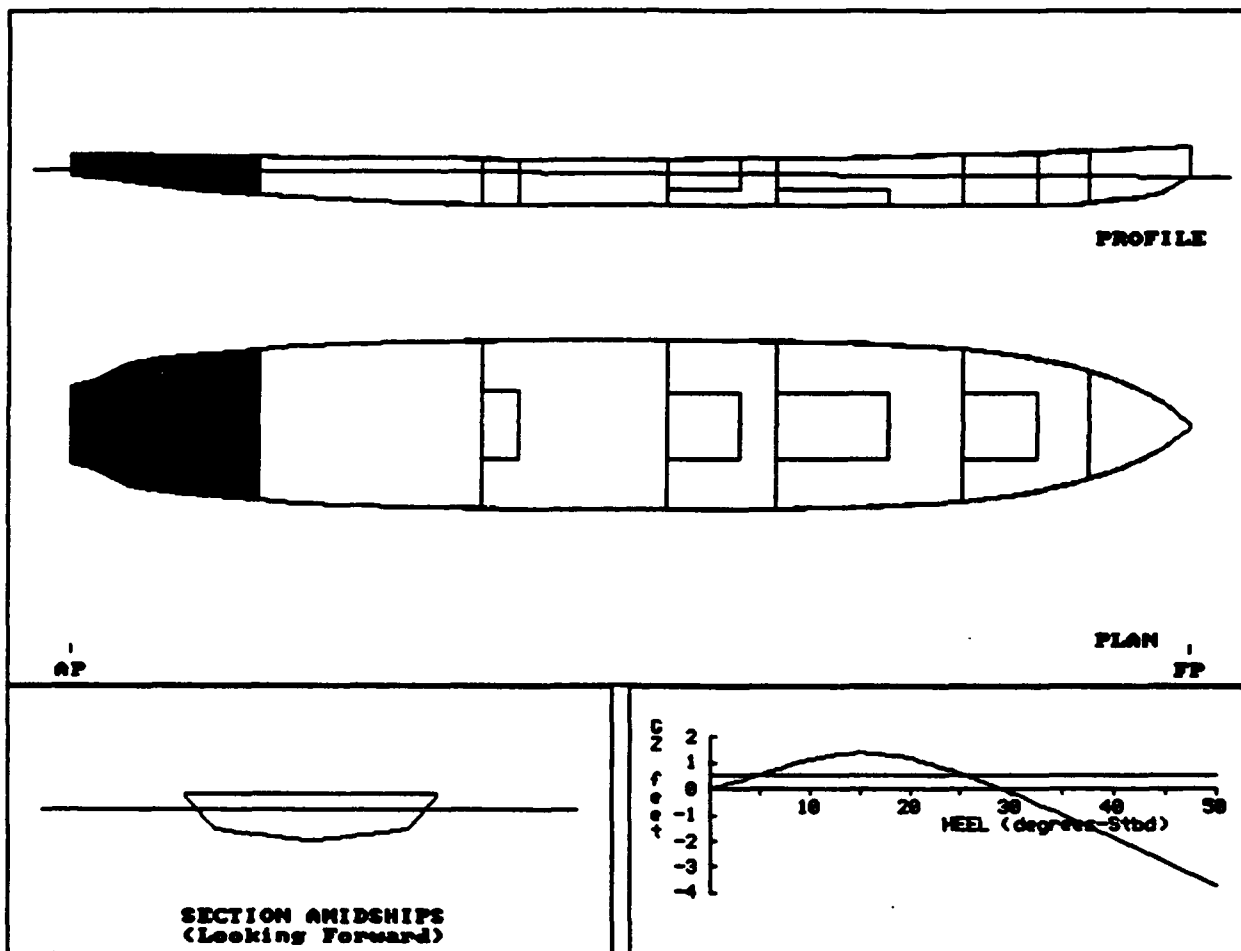

DPRT010A:
 183' DINNER BOAT

COMPARTMENT FLOODING SUMMARY

At 0.0o Heel	PERM.	FLOODED WTR LTons	% FULL (Damaged)	% FULL (Intact)	SP.VOL. ft3/LT	OUTFLOW LTons
LAZARETTE	0.95	38.5	FREE	0.0	----	----
Totals		38.5				

INTACT DATA

Draft at AP = 7.500 ft	Kmt = 24.169 ft	LCG = 91.829A ft-FP
Draft at FP = 7.500 ft	VCG = 16.750 ft	LCB = 91.829A ft-FP
Displacement = 715.8 LTons	Gmt = 7.419 ft	TCG = 0.000 ft-CL

DRAFT/GZ DATA

HEEL degrees	RIGHTING ARM ft	DRAFT AFT ft	DRAFT FWD ft	FLOODED WATER LTons
0.00	0.000	8.517	6.846	38.5
5.00S	0.556	8.496	6.781	38.9
7.00S	0.792	8.463	6.731	39.2
10.00S	1.151	8.391	6.634	39.9
15.00S	1.396	8.544	6.326	45.4
20.00S	1.169	8.921	6.032	50.7
30.00S	-0.143	10.020	5.400	56.9
40.00S	-1.881	11.499	4.709	60.8
50.00S	-3.725	13.552	3.855	63.5

Note: Drafts are measured at A.P. and F.P along ship's centerline

GZ SUMMARY (Evaluated per IMO (SOLAS'90) Rules for Passenger Ships)

	Available	Required
Static Heel Angle	0.00 deg	7.00 deg
Angle at Maximum GZ	16.00S deg	
Maximum GZ	1.396 ft	0.560 ft
Range of Positive GZ	29.11 deg	15.00 deg
Gmt (upright damaged)	6.267 ft	
Righting Area (0.00-7.00)	20.954 ft-deg	2.820 ft-deg

**DPRT011A:
 183' DINNER BOAT**

Damaged Compartments:
 LAZARETTE AFT BALLAST

	DISPLACEMENT LTons	DRAFT AFT ft	DRAFT FWD ft	TRIM ft	HEEL deg.	UPRIGHT Gmt ft
INTACT	715.8	7.500	7.500	0.000	0.00	7.419
DAMAGED	795.9	9.534	6.210	3.323A	0.00	6.575

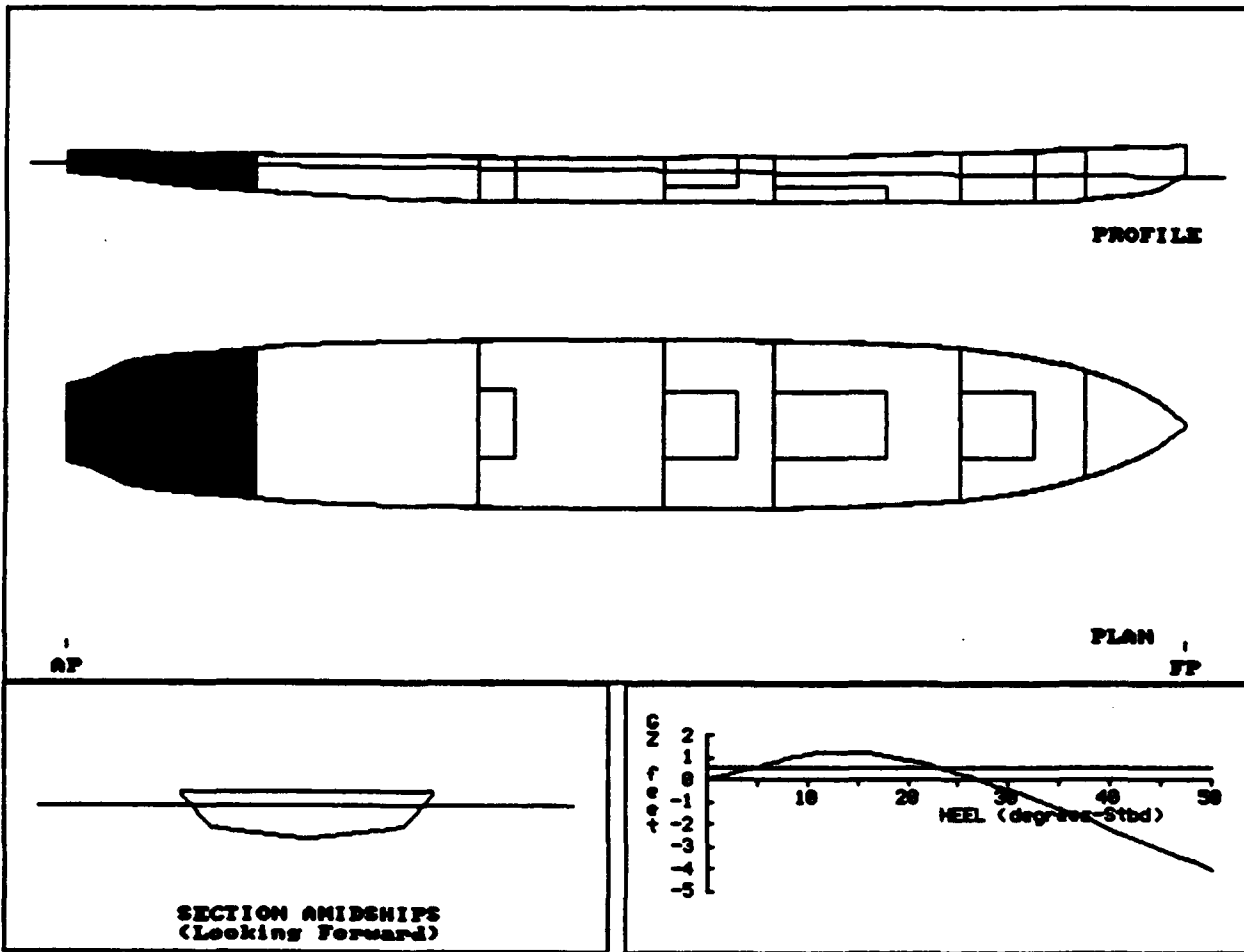

DPRT011A:
 183' DINNER BOAT

COMPARTMENT FLOODING SUMMARY

At 0.0o Heel	PERM.	FLOODED WTR LTons	% FULL (Damaged)	% FULL (Intact)	SP.VOL. ft3/LT	OUTFLOW LTons
LAZARETTE	0.95	52.9	FREE	0.0	----	----
AFT BALLAST	0.95	27.2	FREE	0.0	----	----
Totals		80.1				

INTACT DATA

Draft at AP = 7.500 ft Kmt = 24.169 ft LCG = 91.829A ft-FP
 Draft at FP = 7.500 ft VCG = 16.750 ft LCB = 91.829A ft-FP
 Displacement = 715.8 LTons GMT = 7.419 ft TCG = 0.000 ft-CL

DRAFT/GZ DATA

HEEL degrees	RIGHTING ARM ft	DRAFT AFT ft	DRAFT FWD ft	FLOODED WATER LTons
0.00	0.000	9.534	6.210	80.1
5.00S	0.582	9.513	6.142	80.5
7.00S	0.824	9.472	6.099	80.5
10.00S	1.150	9.421	6.005	81.0
15.00S	1.248	9.789	5.633	87.2
20.00S	0.925	10.577	5.129	94.7
30.00S	-0.437	12.705	4.039	105.0
40.00S	-2.185	15.511	2.749	111.4
50.00S	-4.007	19.293	1.145	115.5

Note: Drafts are measured at A.P. and F.P along ship's centerline

GZ SUMMARY (Evaluated per IMO (SOLAS'90) Rules for Passenger Ships)
 Available Required

Static Heel Angle	0.00 deg	7.00 deg
Angle at Maximum GZ	14.00S deg	
Maximum GZ	1.274 ft	0.560 ft
Range of Positive GZ	27.25 deg	15.00 deg
Gmt (upright damaged)	6.575 ft	
Righting Area (0.00-7.00)	19.267 ft-deg	2.820 ft-deg

**APPENDIX B
HYDROSTATICS AND
DAMAGE STABILITY
OUTPUT**

30' PADDLE WHEELER

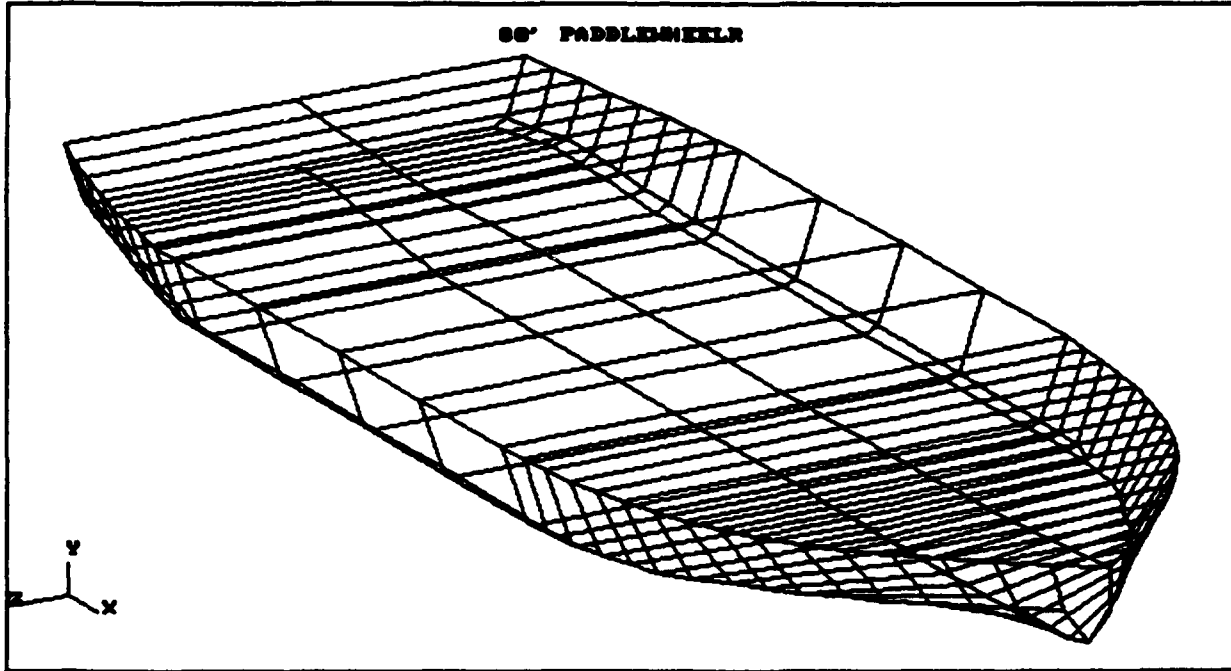

DAMAGE STABILITY SUMMARY
80' PADDLEWHEELR

CASE No.	FILE NAME	DAMAGED COMP. LISTING	---Intact Condition---			-----Equilibrium Condition After Damage-----					
			MN.DRAFT (ft)	VCG (ft)	Ght (ft)	HEEL (deg)	MAX.GZ (ft)	RANGE (deg)	AREA (ft-deg)	DAM.Ght (ft)	SURVIVAL
1	DPRT001A	1	4.798	12.757	6.921	0.0	1.277	27.3	19.4	6.904	Yes
2	DPRT002A	2	4.798	12.757	6.921	0.0	1.089	25.5	16.3	6.586	Yes
3	DPRT003A	1,2	4.798	12.757	6.921	0.0	0.940	22.6	13.3	6.687	Yes
4	DPRT004A	2,3	4.798	12.757	6.921	0.0	1.122	25.3	16.7	6.730	Yes
5	DPRT005A	1,2,3	4.798	12.757	6.921	0.0	0.955	22.2	13.2	6.840	Yes
6	DPRT006A	4	4.798	12.757	6.921	0.0	0.879	23.0	12.4	5.954	Yes
7	DPRT007A	6	4.798	12.757	6.921	0.0	0.805	21.9	10.8	5.528	Yes
8	DPRT008A	8	4.798	12.757	6.921	0.0	0.283	11.2	2.0	3.603	No *F
9	DPRT009A	10	4.798	12.757	6.921	0.0	0.392	13.2	3.2	4.632	No *F
10	DPRT010A	11	4.798	12.757	6.921	0.0	0.706	19.7	8.5	5.420	Yes
11	DPRT011A	12	4.798	12.757	6.921	0.0	0.851	21.8	11.3	5.678	Yes

*F WARNING: The required Ght for non-survival cases does not meet all survival criteria.

**DAMAGE STABILITY SUMMARY
 80' PADDLEWHEELR**

CA. No.	FILE NAME	DAMAGED COMP. LISTING	---Intact Condition---			-----Equilibrium Condition After Damage-----					
			MW.DRAFT (ft)	VCG (ft)	GMt (ft)	HEEL (deg)	MAX.GZ (ft)	RANGE (deg)	AREA (ft-deg)	DAM.GMt (ft)	SURVIVAL
1	RTRN001A	1	4.340	13.690	7.027	0.0	1.476	28.5	22.2	6.962	Yes
2	RTRN002A	2	4.340	13.690	7.027	0.0	1.345	27.2	20.1	6.630	Yes
3	RTRN003A	1,2	4.340	13.690	7.027	0.0	1.316	26.8	19.6	6.672	Yes
4	RTRN004A	2,3	4.340	13.690	7.027	0.0	1.333	27.1	20.0	6.720	Yes
5	RTRN005A	1,2,3	4.340	13.690	7.027	0.0	1.282	26.0	19.0	6.779	Yes
6	RTRN006A	4	4.340	13.690	7.027	0.0	1.113	25.4	16.3	5.907	Yes
7	RTRN007A	6	4.340	13.690	7.027	0.0	0.990	24.0	14.0	5.417	Yes
8	RTRN008A	8	4.340	13.690	7.027	0.0	0.355	13.2	2.8	3.267	No *F
9	RTRN009A	10	4.340	13.690	7.027	0.0	0.315	13.2	2.7	4.523	No *F
10	RTRN010A	11	4.340	13.690	7.027	0.0	0.670	19.3	8.2	5.430	Yes
11	RTRN011A	12	4.340	13.690	7.027	0.0	0.809	21.0	10.7	5.719	Yes

*F WARNING: The required GMt for non-survival cases does not meet all survival criteria.

HYDROSTATIC TABLES
 80' PADDLEWHEELR

MOLDED DRAFT (ft)		1.000	2.000	2.490	2.510	3.000	4.000	5.000
DISP. MLD. (LTons-SW)		39	87	113	114	142	201	260
DISP. TOTAL (LTons-SW)		39	88	114	115	143	202	262
DISP. TOTAL (LTons-FW)		38	86	111	112	139	197	255
LCB (ft-FP)		43.530A	42.956A	42.989A	42.993A	43.351A	43.762A	43.939A
LCB (forebody) (ft-FP)		28.941A	27.360A	26.898A	26.882A	26.536A	26.039A	25.705A
LCB (aftbody) (ft-FP)		53.947A	54.984A	55.496A	55.516A	56.268A	57.210A	57.731A
TCB (ft-CL)		0.000	0.000	0.000	0.000	0.000	0.000	0.000
KB (ft)		0.542	1.083	1.350	1.361	1.635	2.178	2.711
BMT (ft)		74.792	39.090	31.499	31.251	27.008	20.152	16.328
KMT (ft)		75.334	40.173	32.849	32.612	28.643	22.330	19.039
BMI (ft)		294.611	196.135	166.038	164.922	163.312	120.576	95.931
KMI (ft)		295.152	197.218	167.388	166.283	164.947	122.755	98.642
	(LTons)	3.7	4.3	4.5	4.5	4.8	4.9	5.0
	(ft-LTons)	12	18	20	20	24	25	26
	(LTons)	0.1	0.2	0.2	0.2	0.3	0.3	0.3
LCF (ft-FP)		42.027A	42.851A	43.062A	43.068A	44.909A	44.643A	44.446A
W.P. AREA (ft ²)		1,562	1,811	1,877	1,879	2,023	2,070	2,112
WETTED SUR. (ft ²)		1,617	1,961	2,077	2,081	2,290	2,481	2,672
MAX. BEAM (ft)		29.424	29.852	30.062	30.070	30.280	30.708	31.137
LENGTH W.L. (ft)		68.030	72.628	74.646	74.729	79.147	79.691	80.000
Cb		0.5265	0.5964	0.6215	0.6225	0.6483	0.6861	0.7123
Cb (forebody)		0.4386	0.5194	0.5436	0.5445	0.5633	0.5921	0.6135
Cb (aftbody)		0.6143	0.6735	0.6994	0.7004	0.7333	0.7802	0.8111
Cm		0.8826	0.9044	0.9106	0.9109	0.9161	0.9253	0.9335
Cp		0.5966	0.6595	0.6825	0.6834	0.7077	0.7415	0.7630
Cip		0.6102	0.7076	0.7331	0.7339	0.7901	0.8084	0.8252
Cit		0.4615	0.5464	0.5713	0.5722	0.6156	0.6482	0.6815

Assumes: Sea Water at 35.0063 ft³/LT
 Fresh Water at 35.8814 ft³/LT
 Ship floating at even keel (no heel or trim)

DPRT001A:
 80' PADDLEWHEELR

Damaged Compartments:
 FOREPEAK

	DISPLACEMENT LTons	DRAFT AFT ft	DRAFT FWD ft	TRIM ft	HEEL deg.	UPRIGHT GMT ft
INTACT	247	4.466	5.130	0.664F	0.0	6.921
DAMAGED	252	4.262	5.555	1.293F	0.0	6.904

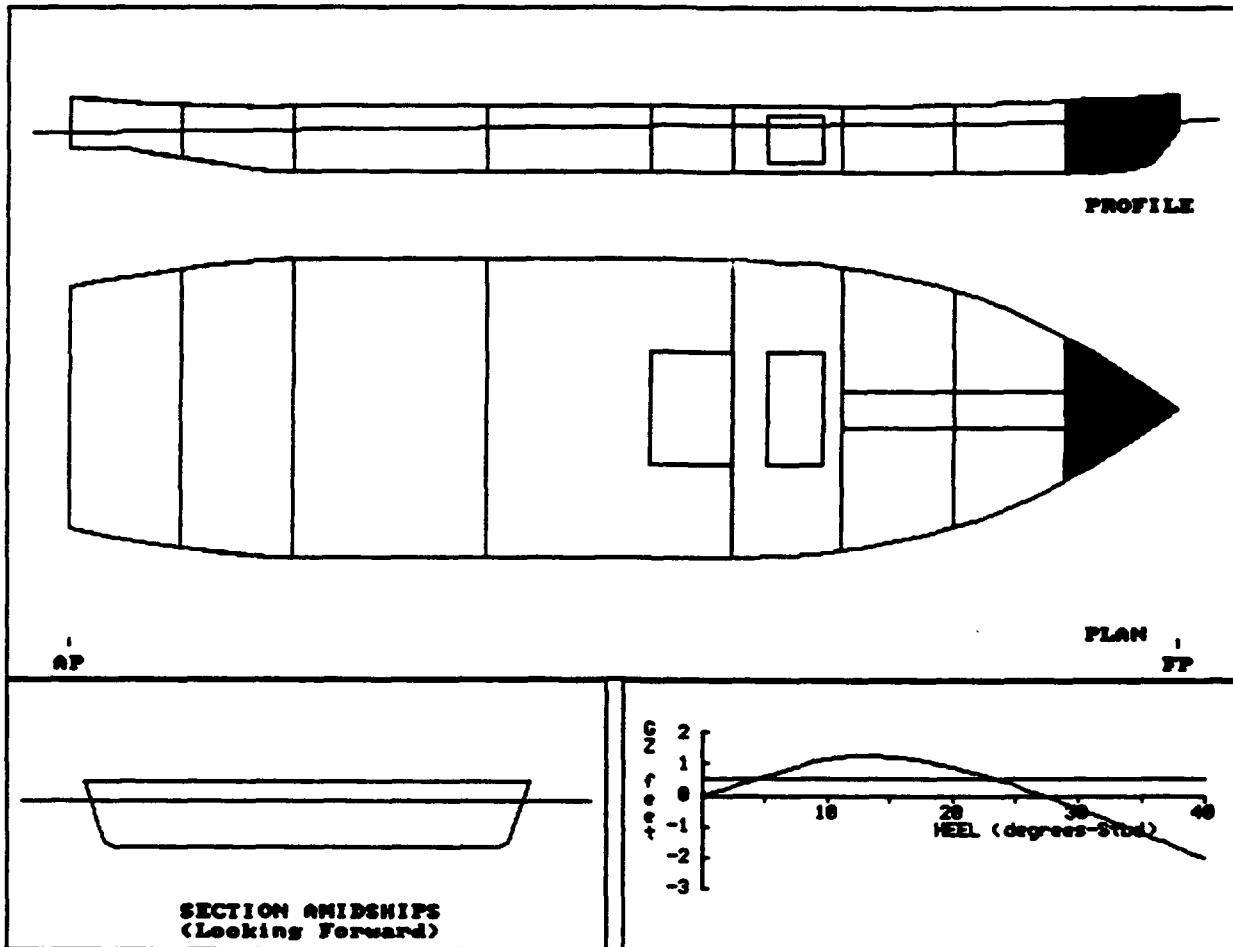

DPRT001A:
 80' PADDLEWHEELR

COMPARTMENT FLOODING SUMMARY

At 0.0o Heel	PERM.	FLOODED WTR LTons	% FULL (Damaged)	% FULL (Intact)	SP.VOL. ft3/LT	OUTFLOW LTons
FOREPEAK	0.95	5	FREE	0.0	----	----
Totals		5				

INTACT DATA

Draft at AP = 4.466 ft	Kmt = 19.678 ft	LCG = 43.154A ft-FP
Draft at FP = 5.130 ft	VCG = 12.757 ft	LCB = 43.069A ft-FP
Displacement = 247 LTons	Gmt = 6.921 ft	TCG = 0.000 ft-CL

DRAFT/GZ DATA

HEEL degrees	RIGHTING ARM ft	DRAFT AFT ft	DRAFT FWD ft	FLOODED WATER LTons
0.0	0.000	4.262	5.555	5
5.0S	0.608	4.253	5.535	5
7.0S	0.858	4.243	5.517	5
10.0S	1.181	4.215	5.524	5
15.0S	1.232	4.211	5.809	5
20.0S	0.898	4.312	6.308	6
30.0S	-0.407	4.491	7.745	7
40.0S	-2.023	4.606	9.677	8

Note: Drafts are measured at A.P. and F.P along ship's centerline

GZ SUMMARY (Evaluated per IMO (SOLAS'90) Rules for Passenger Ships)
 Available Required

Static Heel Angle	0.0 deg	7.0 deg
Angle at Maximum GZ	14.0S deg	
Maximum GZ	1.277 ft	0.520 ft
Range of Positive GZ	27.3 deg	15.0 deg
Gmt (upright damaged)	6.904 ft	
Righting Area (0.0-22.0)	19.36 ft-deg	2.82 ft-deg

DPR002A:
 80' PADDLEWHEELR

Damaged Compartments:
 TANKS

	DISPLACEMENT LTons	DRAFT AFT ft	DRAFT FWD ft	TRIM ft	HEEL deg.	UPRIGHT GMT ft
INTACT	247	4.466	5.130	0.664F	0.0	6.921
DAMAGED	261	4.025	6.169	2.144F	0.0	6.586

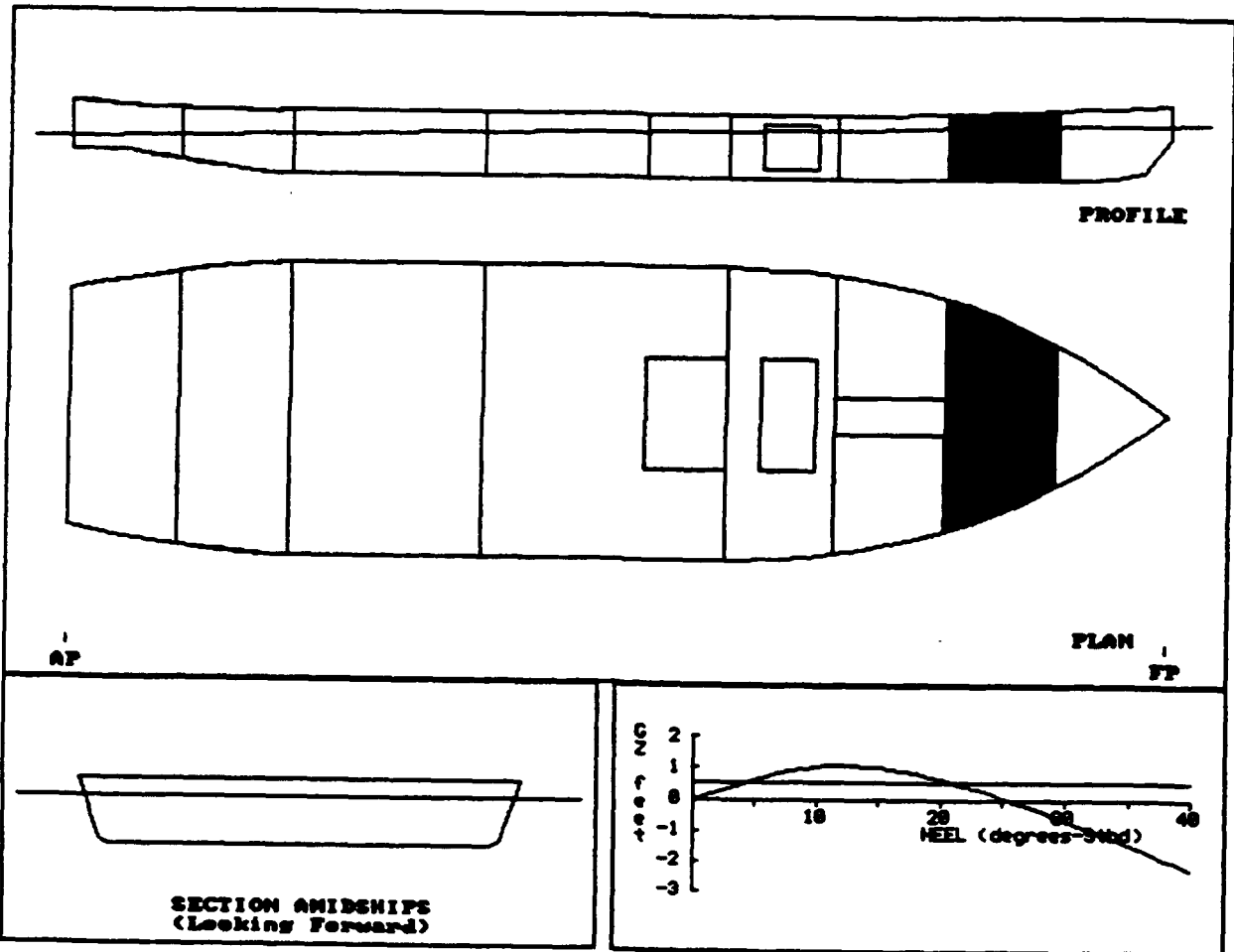

**DPRT002A:
 80' PADDLEWHEELR**

COMPARTMENT FLOODING SUMMARY

At 0.0o Heel	PERM.	FLOODED WTR LTons	% FULL (Damaged)	% FULL (Intact)	SP.VOL. ft ³ /LT	OUTFLOW LTons
TANKS	0.95	13	FREE	0.0	----	----
Totals		13				

INTACT DATA

Draft at AP = 4.466 ft	KMt = 19.678 ft	LCG = 43.154A ft-FP
Draft at FP = 5.130 ft	VCG = 12.757 ft	LCB = 43.069A ft-FP
Displacement = 247 LTons	Gmt = 6.921 ft	TCG = 0.000 ft-CL

DRAFT/GZ DATA

HEEL degrees	RIGHTING ARM ft	DRAFT AFT ft	DRAFT FWD ft	FLOODED WATER LTons
0.0	0.000	4.025	6.169	13
5.0S	0.580	4.011	6.157	13
7.0S	0.815	3.998	6.147	13
10.0S	1.050	3.945	6.242	14
15.0S	1.005	3.879	6.691	14
20.0S	0.642	3.911	7.321	15
30.0S	-0.653	3.887	9.206	15
40.0S	-2.261	3.490	12.182	16

Note: Drafts are measured at A.P. and F.P along ship's centerline

GZ SUMMARY (Evaluated per IMO (SOLAS'90) Rules for Passenger Ships)

	Available	Required
Static Heel Angle	0.0 deg	7.0 deg
Angle at Maximum GZ	13.0S deg	
Maximum GZ	1.089 ft	0.520 ft
Range of Positive GZ	25.5 deg	15.0 deg
Gmt (upright damaged)	6.586 ft	
Righting Area (0.0-22.0)	16.29 ft-deg	2.82 ft-deg

DPR003A:
 80' PADDLEWHEELR

Imaged Compartments:
 FOREPEAK TANKS

	DISPLACEMENT LTons	DRAFT AFT ft	DRAFT FWD ft	TRIM ft	HEEL deg.	UPRIGHT Gmt ft
INTACT	247	4.466	5.130	0.664F	0.0	6.921
DAMAGED	269	3.686	6.889	3.203F	0.0	6.687

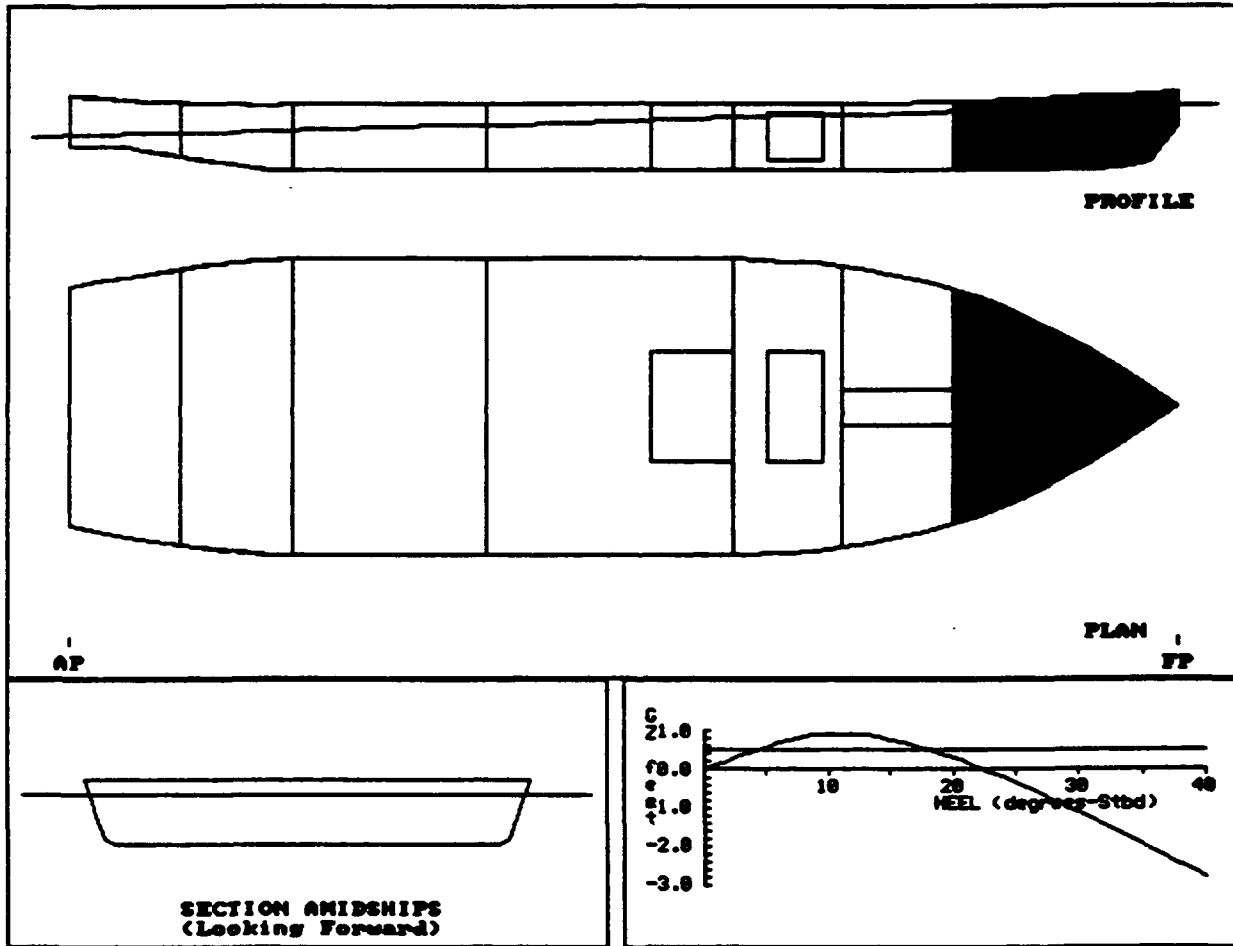

DPRT003A:
 80' PADDLEWHEELR

COMPARTMENT FLOODING SUMMARY

At 0.0o Heel	PERM.	FLOODED WTR LTons	% FULL (Damaged)	% FULL (Intact)	SP.VOL. ft3/LT	OUTFLOW LTons
FOREPEAK	0.95	6	FREE	0.0	----	----
TANKS	0.95	15	FREE	0.0	----	----
Totals		22				

INTACT DATA

Draft at AP = 4.466 ft Kmt = 19.678 ft LCG = 43.154A ft-FP
 Draft at FP = 5.130 ft VCG = 12.757 ft LCB = 43.069A ft-FP
 Displacement = 247 LTons GMT = 6.921 ft TCG = 0.000 ft-CL

DRAFT/GZ DATA

HEEL degrees	RIGHTING ARM ft	DRAFT AFT ft	DRAFT FWD ft	FLOODED WATER LTons
0.0	0.000	3.686	6.889	22
5.0S	0.587	3.663	6.889	22
7.0S	0.787	3.632	6.931	22
10.0S	0.934	3.506	7.208	23
15.0S	0.790	3.251	8.062	24
20.0S	0.325	2.913	9.395	25
30.0S	-1.125	1.720	13.404	27
40.0S	-2.798	-0.306	19.299	28

Note: Drafts are measured at A.P. and F.P along ship's centerline

GZ SUMMARY (Evaluated per IMO (SOLAS'90) Rules for Passenger Ships)
 Available Required

Static Heel Angle	0.0 deg	7.0 deg
Angle at Maximum GZ	12.0S deg	
Maximum GZ	0.940 ft	0.520 ft
Range of Positive GZ	22.6 deg	15.0 deg
Gmt (upright damaged)	6.687 ft	
Righting Area (0.0-22.0)	13.26 ft-deg	2.82 ft-deg

DPRT004A:
 80' PADDLEWHEELR

Imaged Compartments:
 TANKS FO TANK 1

	DISPLACEMENT LTons	DRAFT AFT ft	DRAFT FWD ft	TRIM ft	HEEL deg.	UPRIGHT GMT ft
INTACT	247	4.466	5.130	0.664F	0.0	6.921
DAMAGED	260	4.051	6.110	2.059F	0.0	6.730

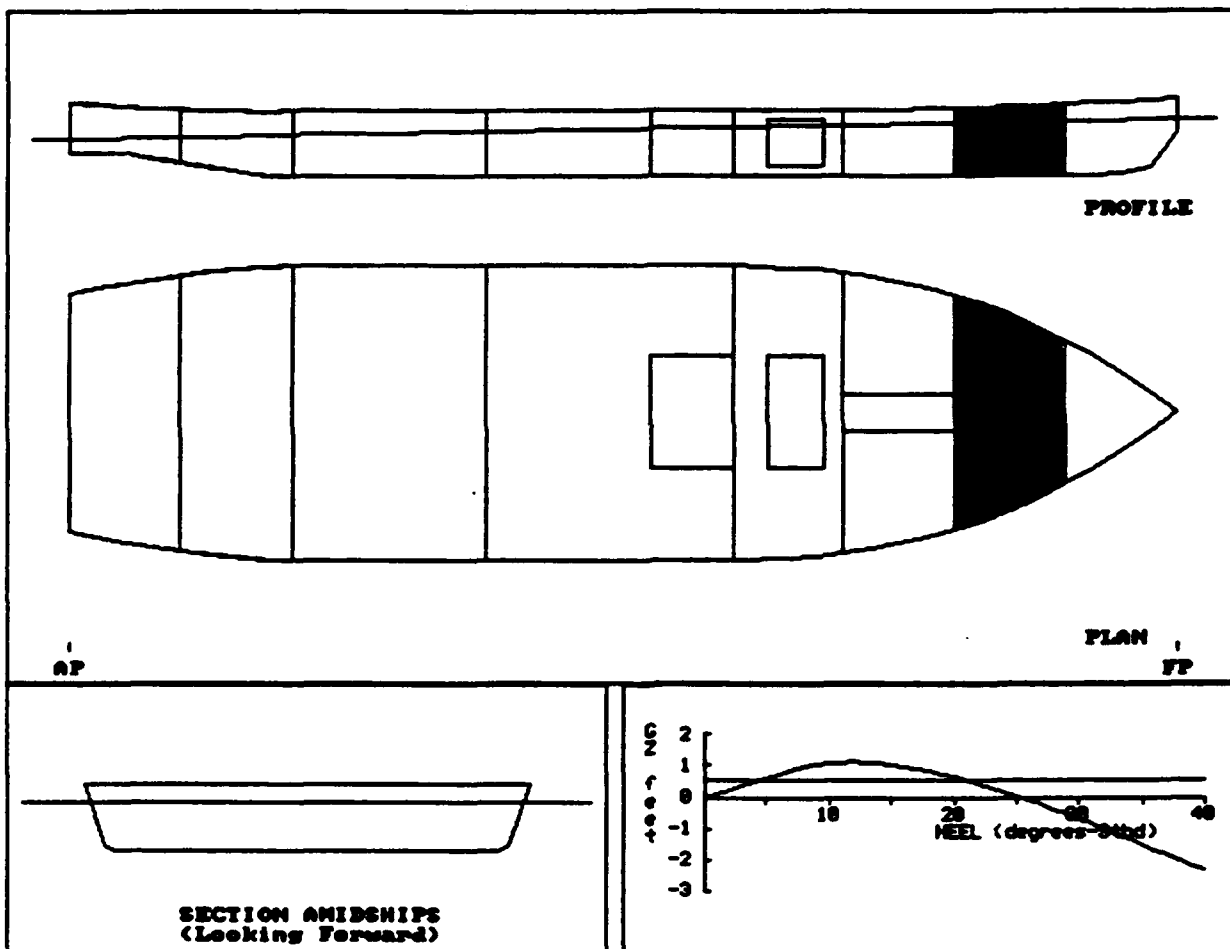

DPRT004A:
 80' PADDLEWHEELR

COMPARTMENT FLOODING SUMMARY

At 0.0o Heel	PERM.	FLOODED WTR LTons	% FULL (Damaged)	% FULL (Intact)	SP.VOL. ft3/LT	OUTFLOW LTons
TANKS	0.95	13	FREE	0.0	----	----
FO TANK 1	0.95	5	FREE	100.0	40.6000	5
Totals		18				5

INTACT DATA

Draft at AP = 4.466 ft Kmt = 19.678 ft LCG = 43.154A ft-FP
 Draft at FP = 5.130 ft VCG = 12.757 ft LCB = 43.069A ft-FP
 Displacement = 247 LTons Gmt = 6.921 ft TCG = 0.000 ft-CL

DRAFT/GZ DATA

HEEL degrees	RIGHTING ARM ft	DRAFT AFT ft	DRAFT FWD ft	FLOODED WATER LTons
0.0	0.000	4.051	6.110	18
5.0S	0.592	4.038	6.096	18
7.0S	0.834	4.025	6.084	18
10.0S	1.081	3.972	6.177	18
15.0S	1.034	3.892	6.660	19
20.0S	0.650	3.890	7.370	20
30.0S	-0.696	3.747	9.492	22
40.0S	-2.343	3.222	12.700	23

Note: Drafts are measured at A.P. and F.P along ship's centerline

GZ SUMMARY (Evaluated per IMO (SOLAS'90) Rules for Passenger Ships)
 Available Required

Static Heel Angle	0.0 deg	7.0 deg
Angle at Maximum GZ	13.0S deg	
Maximum GZ	1.122 ft	0.520 ft
Range of Positive GZ	25.3 deg	15.0 deg
Gmt (upright damaged)	6.730 ft	
Righting Area (0.0-22.0)	16.69 ft-deg	2.82 ft-deg

DPR005A:
80' PADDLEWHEELR

Imaged Compartments:

FOREPEAK TANKS FO TANK 1

	DISPLACEMENT LTons	DRAFT AFT ft	DRAFT FWD ft	TRIM ft	HEEL deg.	UPRIGHT Gmt ft
INTACT	247	4.466	5.130	0.664F	0.0	6.921
DAMAGED	269	3.680	6.894	3.214F	0.0	6.840

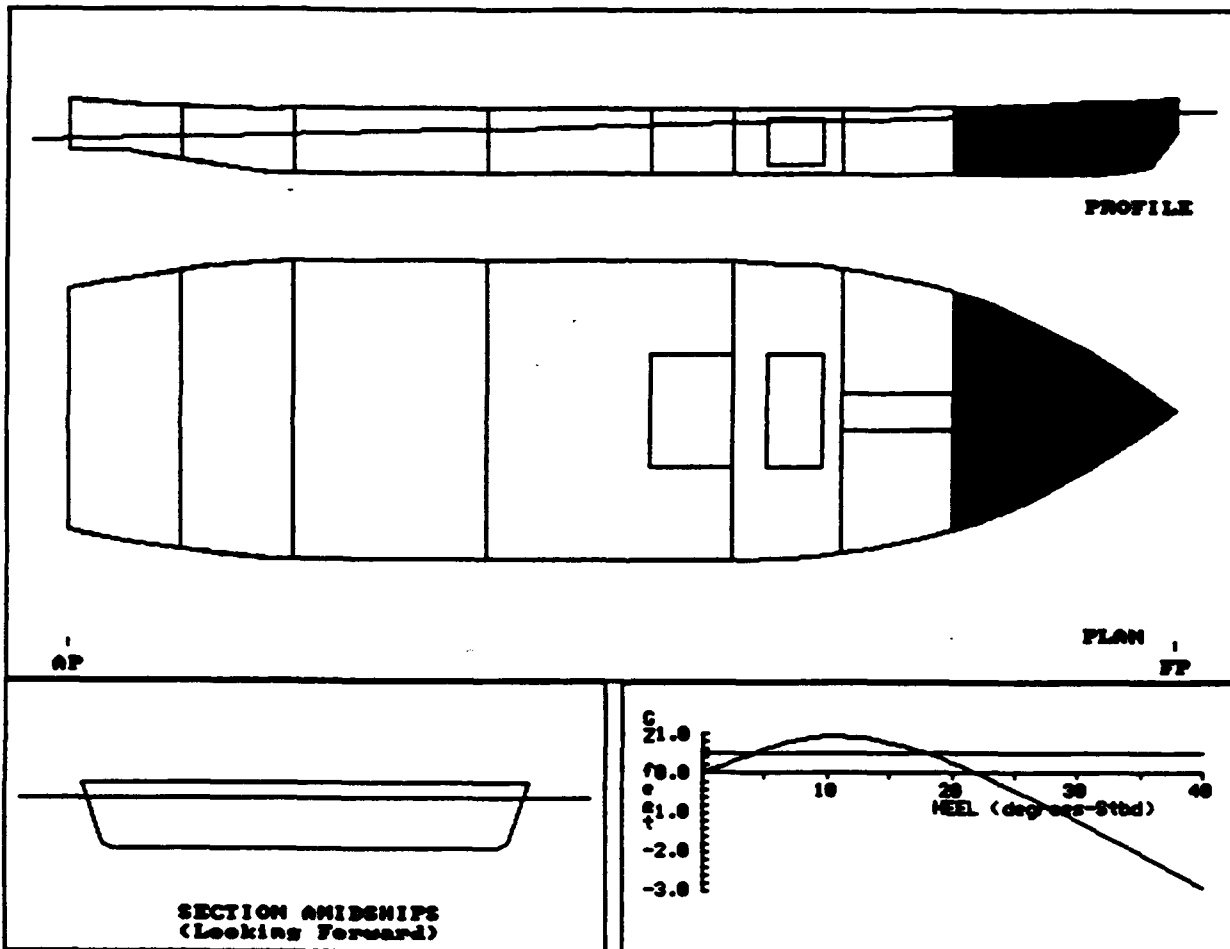

DPRTO05A:
 80' PADDLEWHEELR

COMPARTMENT FLOODING SUMMARY

At 0.0o Heel	PERM.	FLOODED WTR LTons	% FULL (Damaged)	% FULL (Intact)	SP.VOL. ft3/LT	OUTFLOW LTons
FOREPEAK	0.95	6	FREE	0.0	----	----
TANKS	0.95	15	FREE	0.0	----	----
FO TANK 1	0.95	5	FREE	100.0	40.6000	5
Totals		27				5

INTACT DATA

Draft at AP = 4.466 ft	Kmt = 19.678 ft	LCG = 43.154A ft-FP
Draft at FP = 5.130 ft	VCG = 12.757 ft	LCB = 43.069A ft-FP
Displacement = 247 LTons	GMT = 6.921 ft	TCG = 0.000 ft-CL

DRAFT/GZ DATA

HEEL degrees	RIGHTING ARM ft	DRAFT AFT ft	DRAFT FWD ft	FLOODED WATER LTons
0.0	0.000	3.680	6.894	27
5.0S	0.601	3.668	6.879	27
7.0S	0.806	3.636	6.923	27
10.0S	0.953	3.497	7.230	28
15.0S	0.781	3.185	8.219	30
20.0S	0.288	2.795	9.663	32
30.0S	-1.208	1.494	13.871	34
40.0S	-2.922	-0.679	20.053	34

Note: Drafts are measured at A.P. and F.P along ship's centerline

GZ SUMMARY (Evaluated per IMO (SOLAS'90) Rules for Passenger Ships)
 Available Required

Static Heel Angle	0.0 deg	7.0 deg
Angle at Maximum GZ	12.0S deg	
Maximum GZ	0.955 ft	0.520 ft
Range of Positive GZ	22.2 deg	15.0 deg
Gmt (upright damaged)	6.840 ft	
Righting Area (0.0-22.0)	13.21 ft-deg	2.82 ft-deg

DPR006A:
80' PADDLEWHEELR

Damaged Compartments:
 TANKS2

	DISPLACEMENT LTons	DRAFT AFT ft	DRAFT FWD ft	TRIM ft	HEEL deg.	UPRIGHT GMT ft
INTACT	247	4.466	5.130	0.664F	0.0	6.921
DAMAGED	273	3.932	6.730	2.798F	0.0	5.954

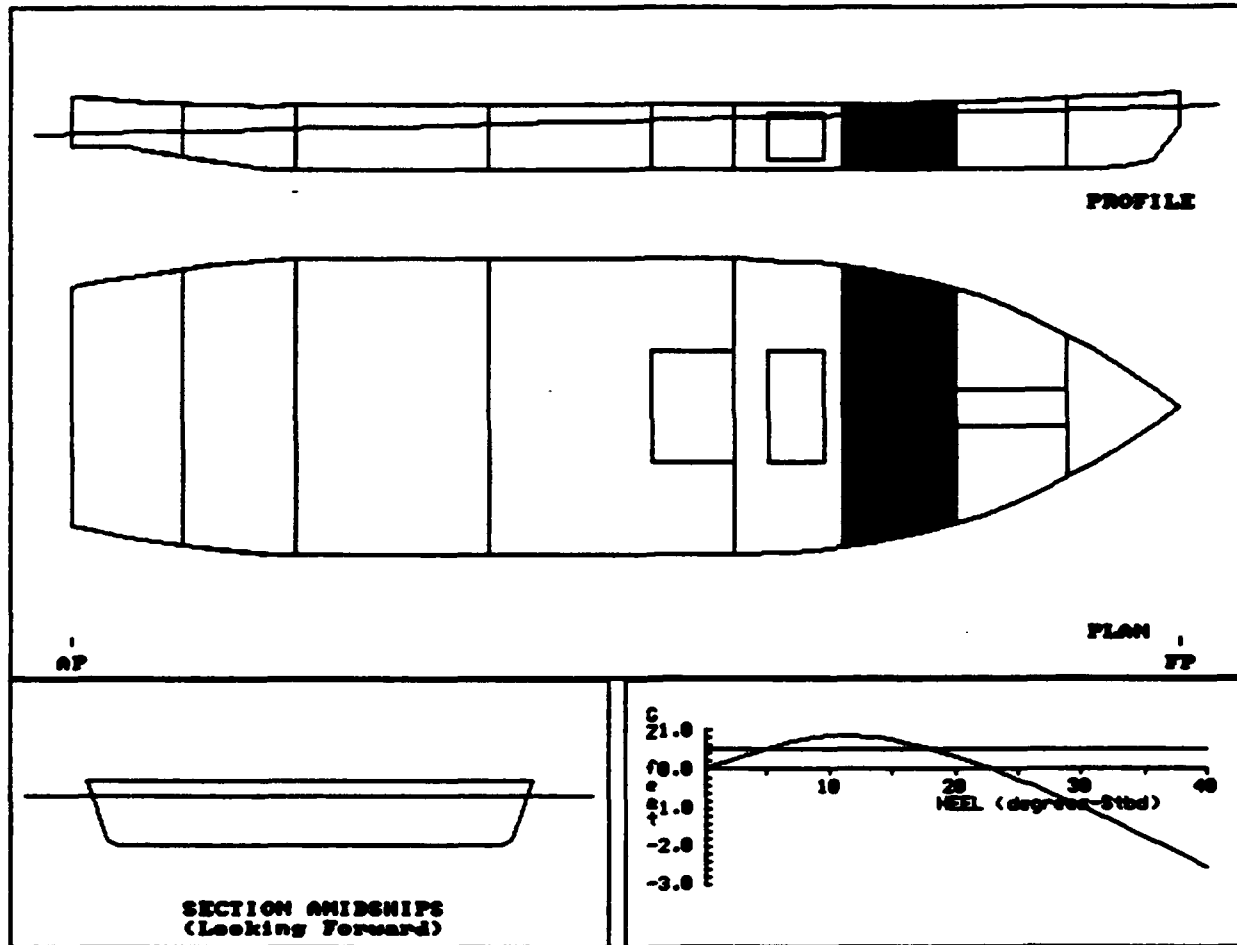

**DPRT006A:
 80' PADDLEWHEELR**

COMPARTMENT FLOODING SUMMARY

At 0.0o Heel	PERM.	FLOODED WTR LTons	% FULL (Damaged)	% FULL (Intact)	SP.VOL. ft3/LT	OUTFLOW LTons
TANKS2	0.95	26	FREE	0.0	----	----
Totals		26				

INTACT DATA

Draft at AP = 4.466 ft	Kmt = 19.678 ft	LCG = 43.154A ft-FP
Draft at FP = 5.130 ft	VCG = 12.757 ft	LCB = 43.069A ft-FP
Displacement = 247 LTons	Gmt = 6.921 ft	TCG = 0.000 ft-CL

DRAFT/GZ DATA

HEEL degrees	RIGHTING ARM ft	DRAFT AFT ft	DRAFT FWD ft	FLOODED WATER LTons
0.0	0.000	3.932	6.730	26
5.0S	0.524	3.917	6.719	26
7.0S	0.717	3.899	6.731	26
10.0S	0.870	3.847	6.871	25
15.0S	0.746	3.786	7.386	25
20.0S	0.342	3.806	8.111	25
30.0S	-0.972	3.681	10.438	25
40.0S	-2.552	3.138	14.049	26

Note: Drafts are measured at A.P. and F.P along ship's centerline

GZ SUMMARY (Evaluated per IMO (SOLAS'90) Rules for Passenger Ships)

	Available	Required
Static Heel Angle	0.0 deg	7.0 deg
Angle at Maximum GZ	12.0S deg	
Maximum GZ	0.879 ft	0.520 ft
Range of Positive GZ	23.0 deg	15.0 deg
Gmt (upright damaged)	5.954 ft	
Righting Area (0.0-22.0)	12.45 ft-deg	2.82 ft-deg

DPR007A:
 80' PADDLEWHEELR

Damaged Compartments:
 COMPT 3

	DISPLACEMENT LTons	DRAFT AFT ft	DRAFT FWD ft	TRIM ft	HEEL deg.	UPRIGHT GMT ft
INTACT	247	4.466	5.130	0.664F	0.0	6.921
DAMAGED	277	4.209	6.546	2.337F	0.0	5.528

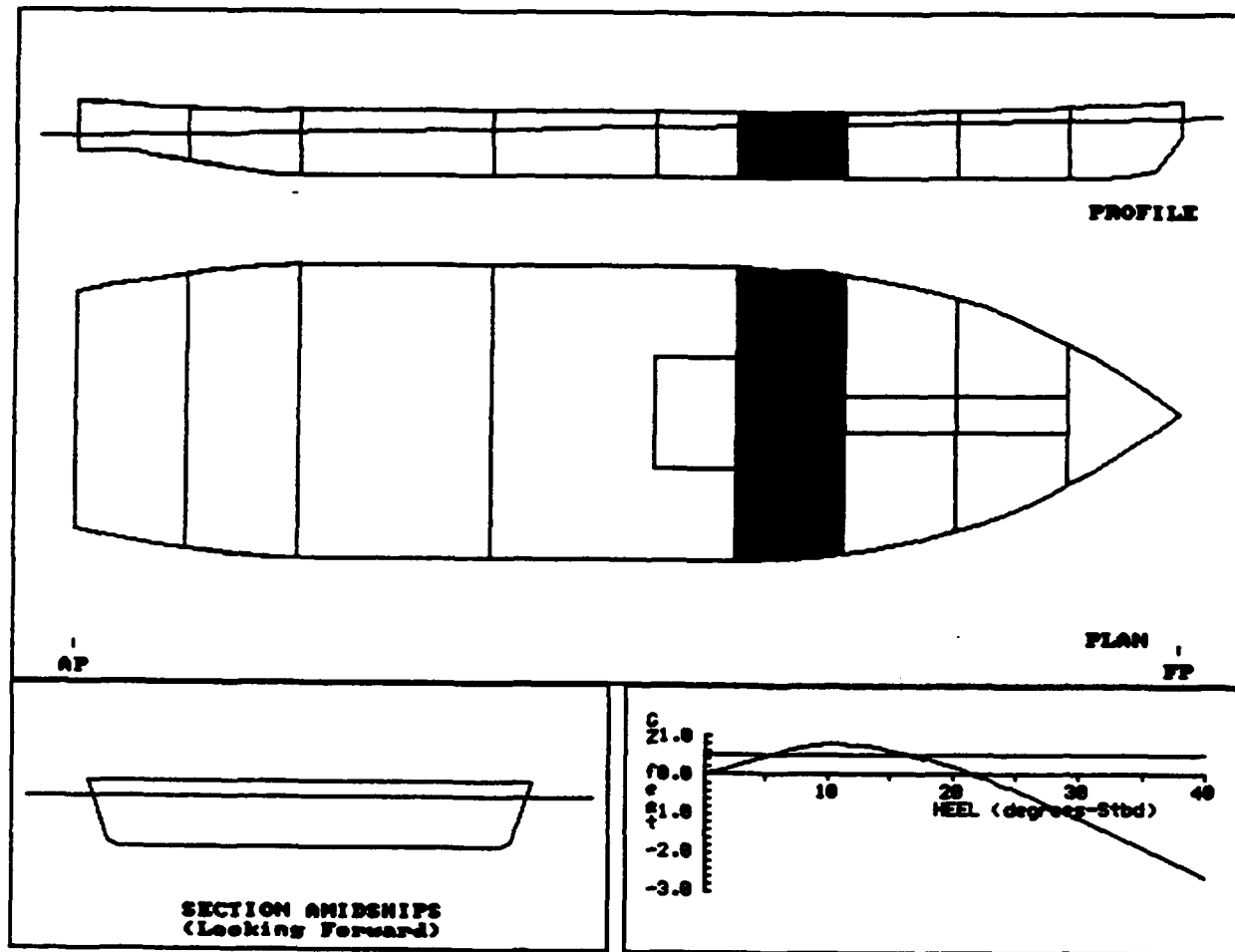

DPRT007A:
 80' PADDLEWHEELR

COMPARTMENT FLOODING SUMMARY

At 0.0o Heel	PERM.	FLOODED WTR LTons	% FULL (Damaged)	% FULL (Intact)	SP.VOL. ft ³ /LT	OUTFLOW LTons
COMPT 3	0.95	30	FREE	0.0	----	----
Totals		30				

INTACT DATA

Draft at AP = 4.466 ft KMt = 19.678 ft LCG = 43.154A ft-FP
 Draft at FP = 5.130 ft VCG = 12.757 ft LCB = 43.069A ft-FP
 Displacement = 247 LTons GMT = 6.921 ft TCG = 0.000 ft-CL

DRAFT/GZ DATA

HEEL degrees	RIGHTING ARM ft	DRAFT AFT ft	DRAFT FWD ft	FLOODED WATER LTons
0.0	0.000	4.209	6.546	30
5.0S	0.487	4.199	6.528	30
7.0S	0.670	4.184	6.533	30
10.0S	0.804	4.151	6.654	29
15.0S	0.640	4.171	7.093	29
20.0S	0.207	4.309	7.707	28
30.0S	-1.094	4.651	9.450	28
40.0S	-2.633	4.900	11.949	27

Note: Drafts are measured at A.P. and F.P along ship's centerline

GZ SUMMARY (Evaluated per IMO (SOLAS'90) Rules for Passenger Ships)
 Available Required

Static Heel Angle	0.0 deg	7.0 deg
Angle at Maximum GZ	12.0S deg	
Maximum GZ	0.805 ft	0.520 ft
Range of Positive GZ	21.9 deg	15.0 deg
Gmt (upright damaged)	5.528 ft	
Righting Area (0.0-21.9)	10.79 ft-deg	2.82 ft-deg

DPR008A:
 80' PADDLEWHEELR

Imaged Compartments:
 COMPT 4

	DISPLACEMENT LTons	DRAFT AFT ft	DRAFT FWD ft	TRIM ft	HEEL deg.	UPRIGHT GMT ft
INTACT	247	4.466	5.130	0.664F	0.0	6.921
DAMAGED	326	5.452	6.768	1.316F	0.0	3.603

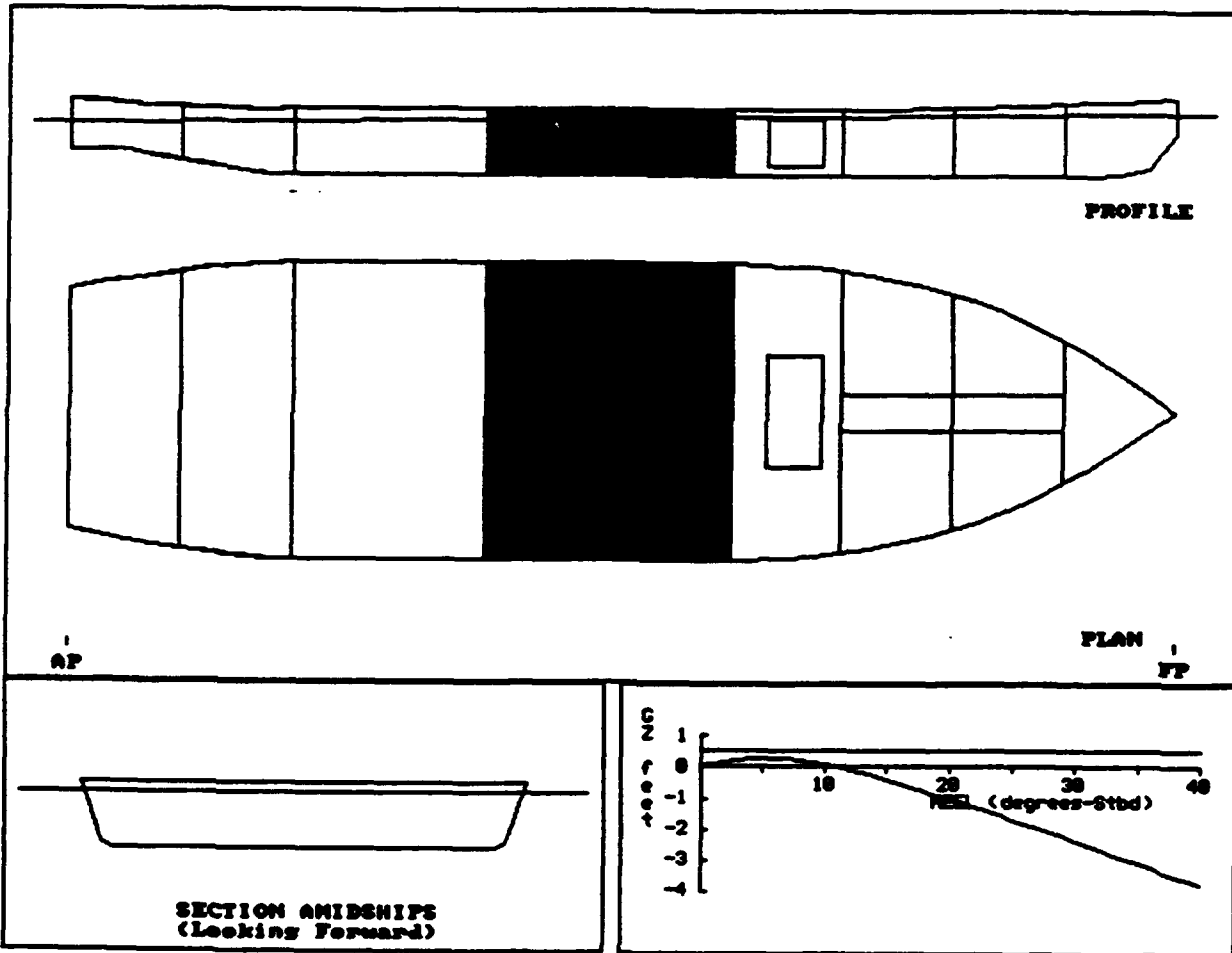

DPRT008A:
 80' PADDLEWHEELR

COMPARTMENT FLOODING SUMMARY

At 0.0o Heel	PERM.	FLOODED WTR LTons	% FULL (Damaged)	% FULL (Intact)	SP.VOL. ft3/LT	OUTFLOW LTons
COMPT 4	0.95	78	FREE	0.0	----	----
Totals		78				

INTACT DATA

Draft at AP = 4.466 ft	Kmt = 19.678 ft	LCG = 43.154A ft-FP
Draft at FP = 5.130 ft	VCG = 12.757 ft	LCB = 43.069A ft-FP
Displacement = 247 LTons	Gmt = 6.921 ft	TCG = 0.000 ft-CL

DRAFT/GZ DATA

HEEL degrees	RIGHTING ARM ft	DRAFT AFT ft	DRAFT FWD ft	FLOODED WATER LTons
0.0	0.000	5.452	6.768	78
5.0S	0.279	5.438	6.790	78
7.0S	0.263	5.445	6.896	77
10.0S	0.096	5.548	7.109	76
15.0S	-0.396	5.915	7.578	75
20.0S	-1.012	6.481	8.126	73
30.0S	-2.375	7.961	9.628	71
40.0S	-3.777	9.873	11.775	70

Note: Drafts are measured at A.P. and F.P along ship's centerline

GZ SUMMARY (Evaluated per IMO (SOLAS'90) Rules for Passenger Ships)
 Available Required

Static Heel Angle	0.0 deg	7.0 deg
Angle at Maximum GZ	7.0S deg	
*** Maximum GZ	0.283 ft	0.520 ft
*** Range of Positive GZ	11.2 deg	15.0 deg
Gmt (upright damaged)	3.603 ft	
Righting Area (0.0-11.2)	1.97 ft-deg	2.82 ft-deg

*** indicates failure to meet criterion

DPR009A:
 80' PADDLEWHEELR

aged Compartments:
 ENGINE ROOM

	DISPLACEMENT LTons	DRAFT AFT ft	DRAFT FWD ft	TRIM ft	HEEL deg.	UPRIGHT GMT ft
INTACT	247	4.466	5.130	0.664F	0.0	6.921
DAMAGED	310	6.719	4.625	2.094A	0.0	4.632

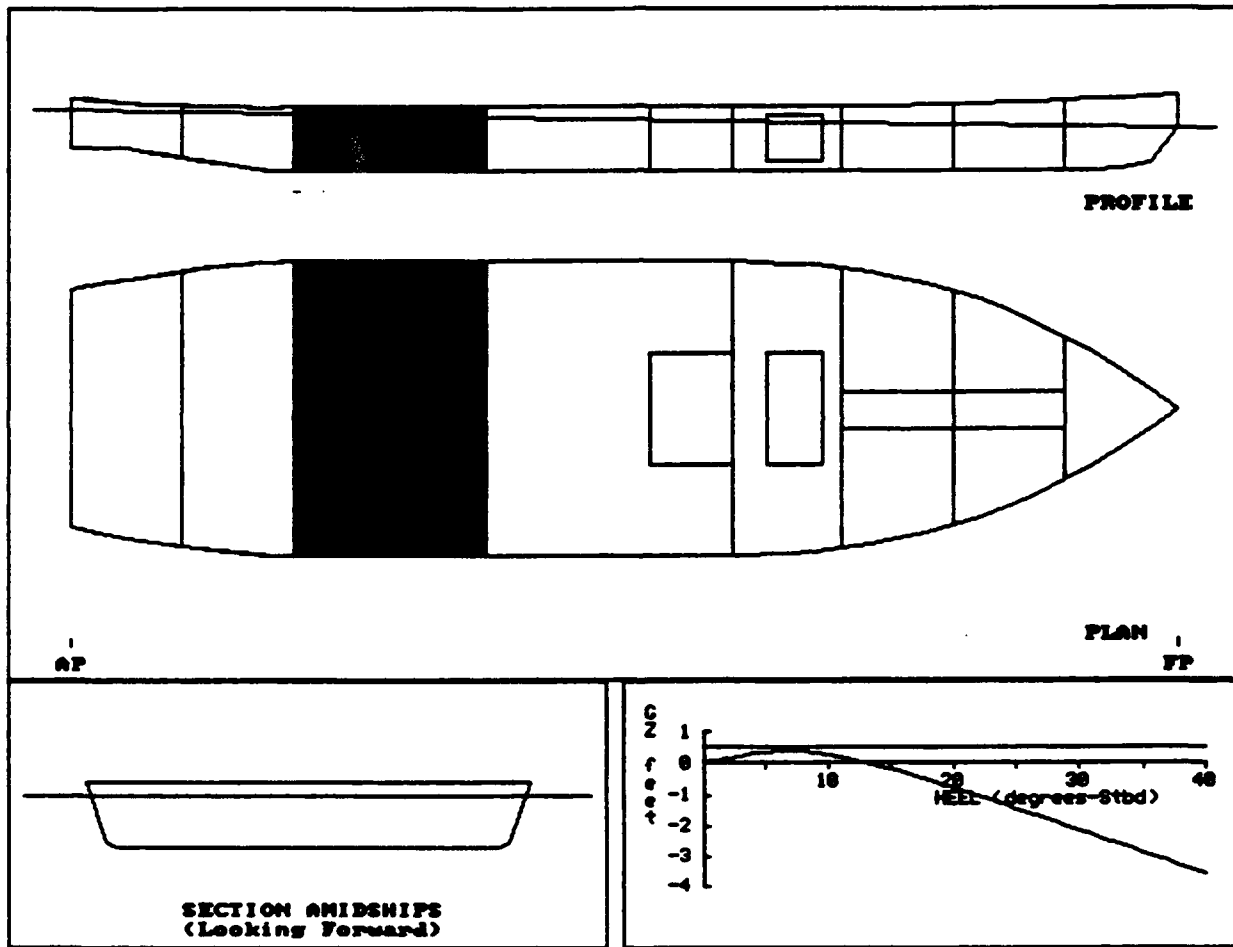

DPRT009A:
 80' PADDLEWHEELR

COMPARTMENT FLOODING SUMMARY

At 0.0o Heel	PERM.	FLOODED WTR LTons	% FULL (Damaged)	% FULL (Intact)	SP.VOL. ft3/LT	OUTFLOW LTons
ENGINE ROOM	0.85	63	FREE	0.0	----	----
Totals		63				

INTACT DATA

Draft at AP = 4.466 ft	KMT = 19.678 ft	LCG = 43.154A ft-FP
Draft at FP = 5.130 ft	VCG = 12.757 ft	LCB = 43.069A ft-FP
Displacement = 247 LTons	GMT = 6.921 ft	TCG = 0.000 ft-CL

DRAFT/GZ DATA

HEEL degrees	RIGHTING ARM ft	DRAFT AFT ft	DRAFT FWD ft	FLOODED WATER LTons
0.0	0.000	6.719	4.625	63
5.0S	0.359	6.769	4.581	63
7.0S	0.392	6.923	4.502	63
10.0S	0.269	7.306	4.389	62
15.0S	-0.181	8.191	4.270	62
20.0S	-0.773	9.327	4.200	62
30.0S	-2.136	12.254	4.093	63
40.0S	-3.589	16.171	3.866	63

Note: Drafts are measured at A.P. and F.P along ship's centerline

GZ SUMMARY (Evaluated per IMO (SOLAS'90) Rules for Passenger Ships)

	Available	Required
Static Heel Angle	0.0 deg	7.0 deg
Angle at Maximum GZ	8.0S deg	
*** Maximum GZ	0.392 ft	0.520 ft
*** Range of Positive GZ	13.2 deg	15.0 deg
Gmt (upright damaged)	4.632 ft	
Righting Area (0.0-13.2)	3.24 ft-deg	2.82 ft-deg

*** indicates failure to meet criterion

DPR010A:
 80' PADDLEWHEELR

Damaged Compartments:
 COMPT 6

	DISPLACEMENT LTons	DRAFT AFT ft	DRAFT FWD ft	TRIM ft	HEEL deg.	UPRIGHT GMT ft
INTACT	247	4.466	5.130	0.664F	0.0	6.921
DAMAGED	282	6.278	4.129	2.149A	0.0	5.420

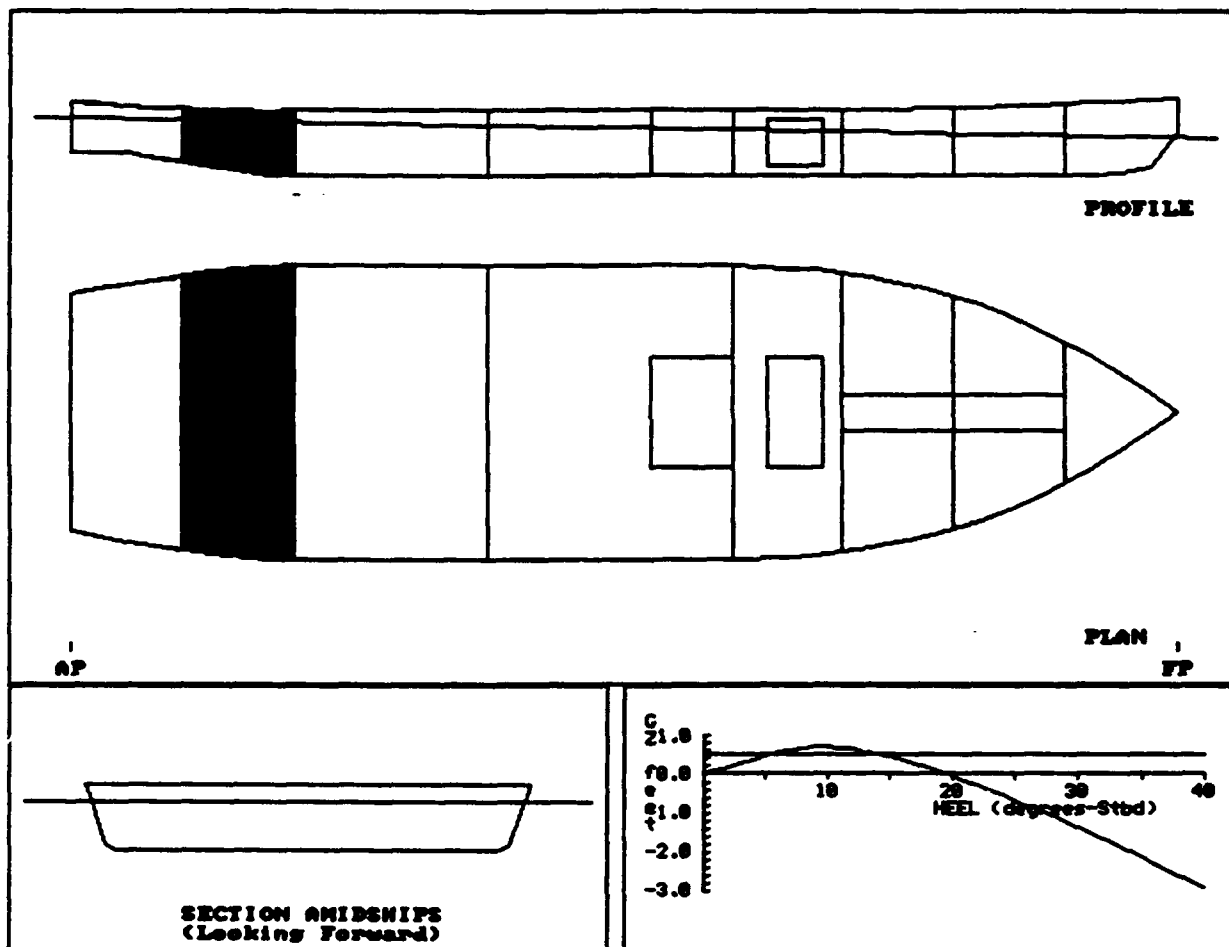

DPRT010A:
 80' PADDLEWHEELR

COMPARTMENT FLOODING SUMMARY

At 0.0o Heel	PERM.	FLOODED WTR LTons	% FULL (Damaged)	% FULL (Intact)	SP.VOL. ft3/LT	OUTFLOW LTons
COMPT 6	0.95	34	FREE	0.0	----	----
Totals		34				

INTACT DATA

Draft at AP = 4.466 ft Kmt = 19.678 ft LCG = 43.154A ft-FP
 Draft at FP = 5.130 ft VCG = 12.757 ft LCB = 43.069A ft-FP
 Displacement = 247 LTons Gmt = 6.921 ft TCG = 0.000 ft-CL

DRAFT/GZ DATA

HEEL degrees	RIGHTING ARM ft	DRAFT APT ft	DRAFT FWD ft	FLOODED WATER LTons
0.0	0.000	6.278	4.129	34
5.0S	0.476	6.279	4.099	34
7.0S	0.638	6.299	4.075	34
10.0S	0.705	6.495	3.985	34
15.0S	0.450	7.145	3.838	34
20.0S	-0.037	8.054	3.735	34
30.0S	-1.377	10.588	3.373	35
40.0S	-2.908	14.011	2.763	35

Note: Drafts are measured at A.P. and F.P along ship's centerline

GZ SUMMARY (Evaluated per IMO (SOLAS'90) Rules for Passenger Ships)
 Available Required

Static Heel Angle	0.0 deg	7.0 deg
Angle at Maximum GZ	10.0S deg	
Maximum GZ	0.706 ft	0.520 ft
Range of Positive GZ	19.7 deg	15.0 deg
Gmt (upright damaged)	5.420 ft	
Righting Area (0.0-19.7)	8.51 ft-deg	2.82 ft-deg

DPR011A:
 80' PADDLEWHEELR

Damaged Compartments:
 COMPT 7

	DISPLACEMENT LTons	DRAFT AFT ft	DRAFT FWD ft	TRIM ft	HEEL deg.	UPRIGHT GMt ft
INTACT	247	4.466	5.130	0.664F	0.0	6.921
DAMAGED	267	5.727	4.264	1.464A	0.0	5.678

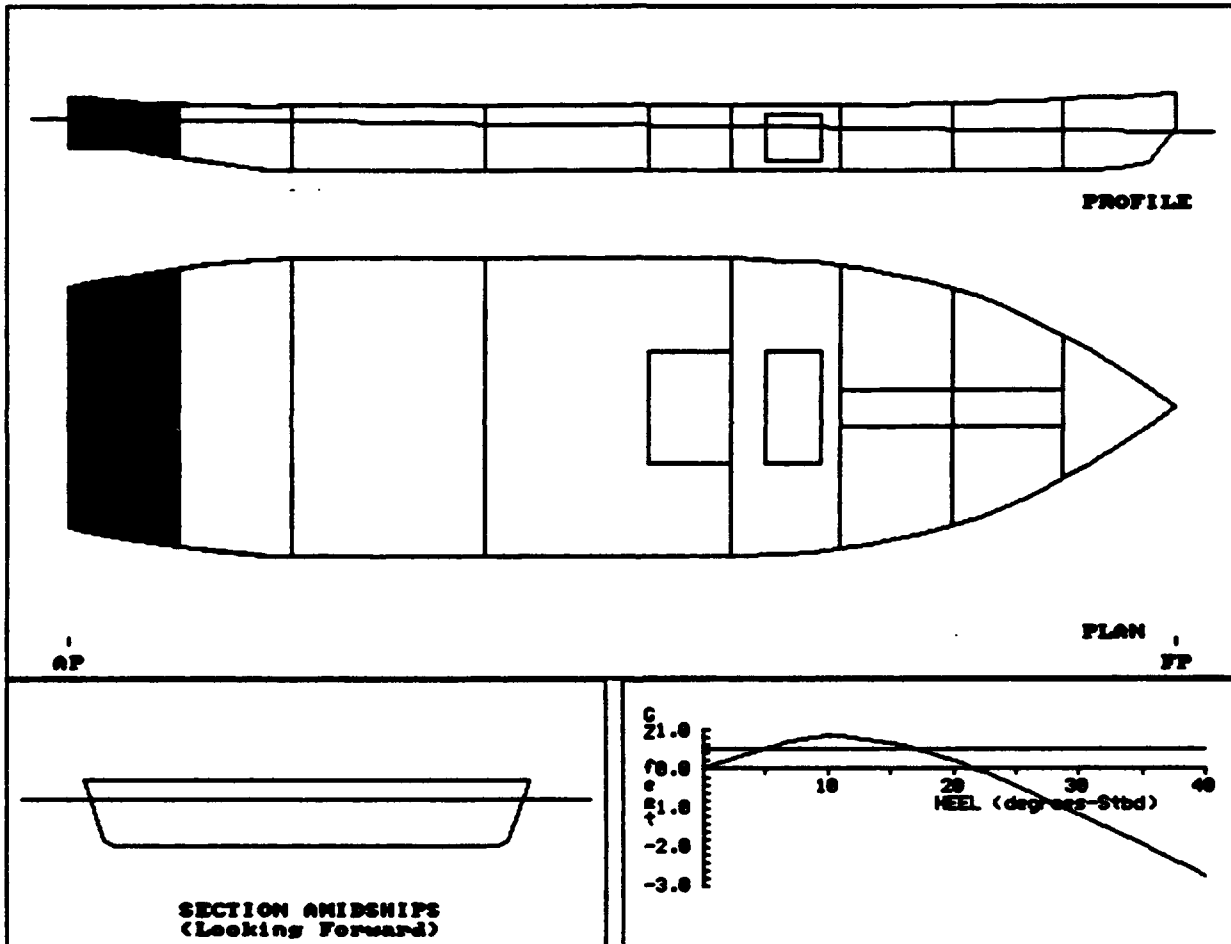

DPRTO11A:
 80' PADDLEWHEELR

COMPARTMENT FLOODING SUMMARY

At 0.0o Heel	PERM.	FLOODED WTR LTons	% FULL (Damaged)	% FULL (Intact)	SP.VOL. ft ³ /LT	OUTFLOW LTons
COMPT 7	0.95	19	FREE	0.0	----	----
Totals		19				

INTACT DATA

Draft at AP = 4.466 ft KMT = 19.678 ft LCG = 43.154A ft-FP
 Draft at FP = 5.130 ft VCG = 12.757 ft LCB = 43.069A ft-FP
 Displacement = 247 LTons GMT = 6.921 ft TCG = 0.000 ft-CL

DRAFT/GZ DATA

HEEL degrees	RIGHTING ARM ft	DRAFT AFT ft	DRAFT FWD ft	FLOODED WATER LTons
0.0	0.000	5.727	4.264	19
5.0S	0.500	5.728	4.235	19
7.0S	0.699	5.726	4.215	19
10.0S	0.849	5.865	4.128	20
15.0S	0.670	6.466	3.954	21
20.0S	0.214	7.359	3.804	22
30.0S	-1.149	9.902	3.264	25
40.0S	-2.736	13.340	2.409	26

Note: Drafts are measured at A.P. and F.P along ship's centerline

GZ SUMMARY (Evaluated per IMO (SOLAS'90) Rules for Passenger Ships)
 Available Required

Static Heel Angle	0.0 deg	7.0 deg
Angle at Maximum GZ	12.0S deg	
Maximum GZ	0.851 ft	0.520 ft
Range of Positive GZ	21.8 deg	15.0 deg
Gmt (upright damaged)	5.678 ft	
Righting Area (0.0-21.8)	11.27 ft-deg	2.82 ft-deg

RTRN001A:
 80' PADDLEWHEELR

aged Compartments:
 FOREPEAK

	DISPLACEMENT LTons	DRAFT AFT ft	DRAFT FWD ft	TRIM ft	HEEL deg.	UPRIGHT GMT ft
INTACT	226	4.980	3.700	1.280A	0.0	7.027
DAMAGED	229	4.857	3.958	0.899A	0.0	6.962

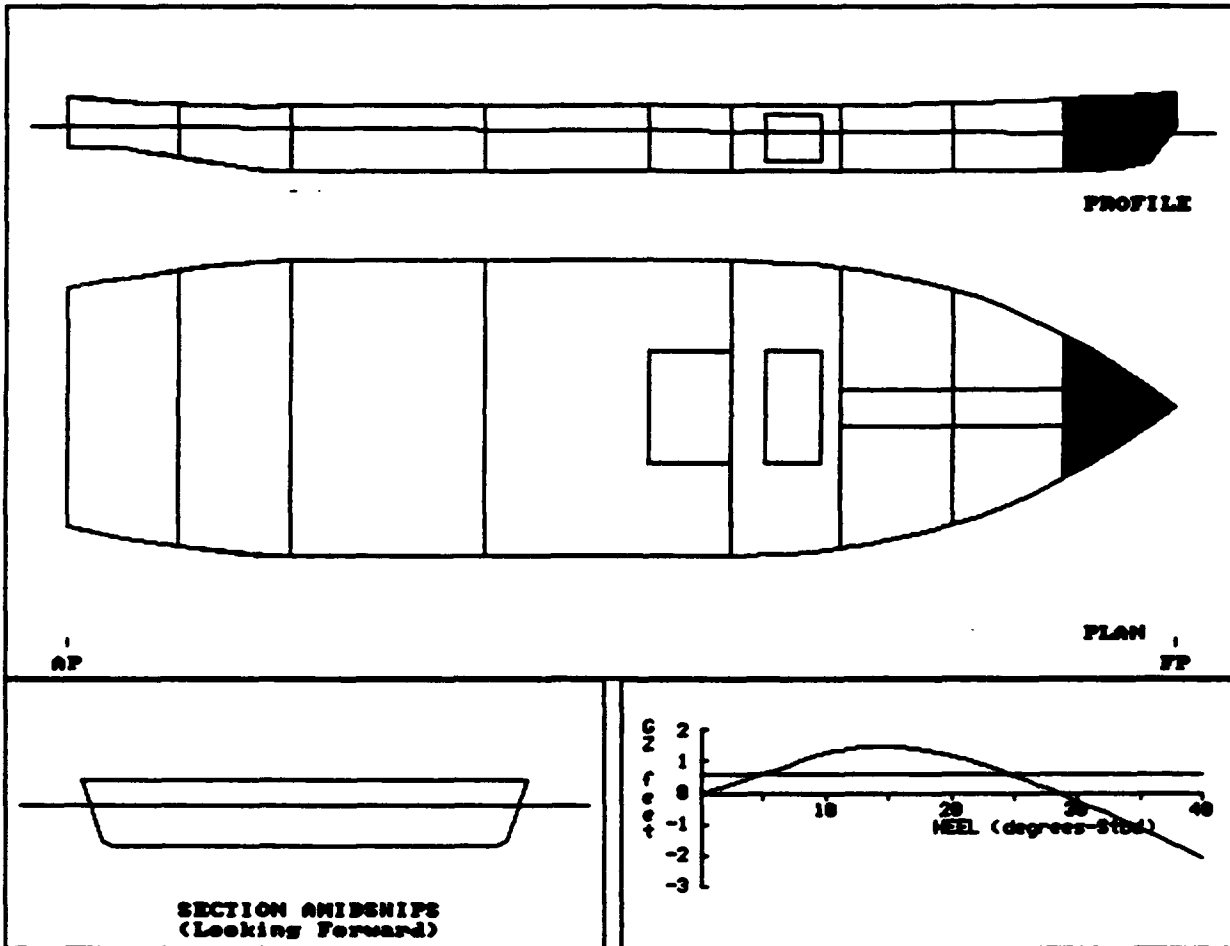

RTRN001A:
 80' PADDLEWHEELR

COMPARTMENT FLOODING SUMMARY

At 0.0o Heel	PERM.	FLOODED WTR LTons	% FULL (Damaged)	% FULL (Intact)	SP.VOL. ft3/LT	OUTFLOW LTons
FOREPEAK	0.95	3	FREE	0.0	----	----
Totals		3				

INTACT DATA

Draft at AP = 4.980 ft Kmt = 20.717 ft LCG = 45.407A ft-FP
 Draft at FP = 3.700 ft VCG = 13.690 ft LCB = 45.587A ft-FP
 Displacement = 226 LTons Gmt = 7.027 ft TCG = 0.000 ft-CL

DRAFT/GZ DATA

HEEL degrees	RIGHTING ARM ft	DRAFT AFT ft	DRAFT FWD ft	FLOODED WATER LTons
0.0	0.000	4.857	3.958	3
5.0S	0.613	4.853	3.930	3
7.0S	0.866	4.843	3.913	3
10.0S	1.249	4.833	3.868	3
15.0S	1.475	4.967	3.834	3
20.0S	1.181	5.324	3.809	3
30.0S	-0.264	6.248	3.692	3
40.0S	-2.061	7.416	3.531	3

Note: Drafts are measured at A.P. and F.P along ship's centerline

GZ SUMMARY (Evaluated per IMO (SOLAS'90) Rules for Passenger Ships)
 Available Required

Static Heel Angle	0.0 deg	7.0 deg
Angle at Maximum GZ	15.0S deg	
Maximum GZ	1.476 ft	0.570 ft
Range of Positive GZ	28.5 deg	15.0 deg
Gmt (upright damaged)	6.962 ft	
Righting Area (0.0-22.0)	22.20 ft-deg	2.82 ft-deg

RTRN002A:
 80' PADDLEWHEELR

Damaged Compartments:
 TANKS

	DISPLACEMENT LTons	DRAFT AFT ft	DRAFT FWD ft	TRIM ft	HEEL deg.	UPRIGHT GMT ft
INTACT	226	4.980	3.700	1.280A	0.0	7.027
DAMAGED	235	4.672	4.426	0.247A	0.0	6.630

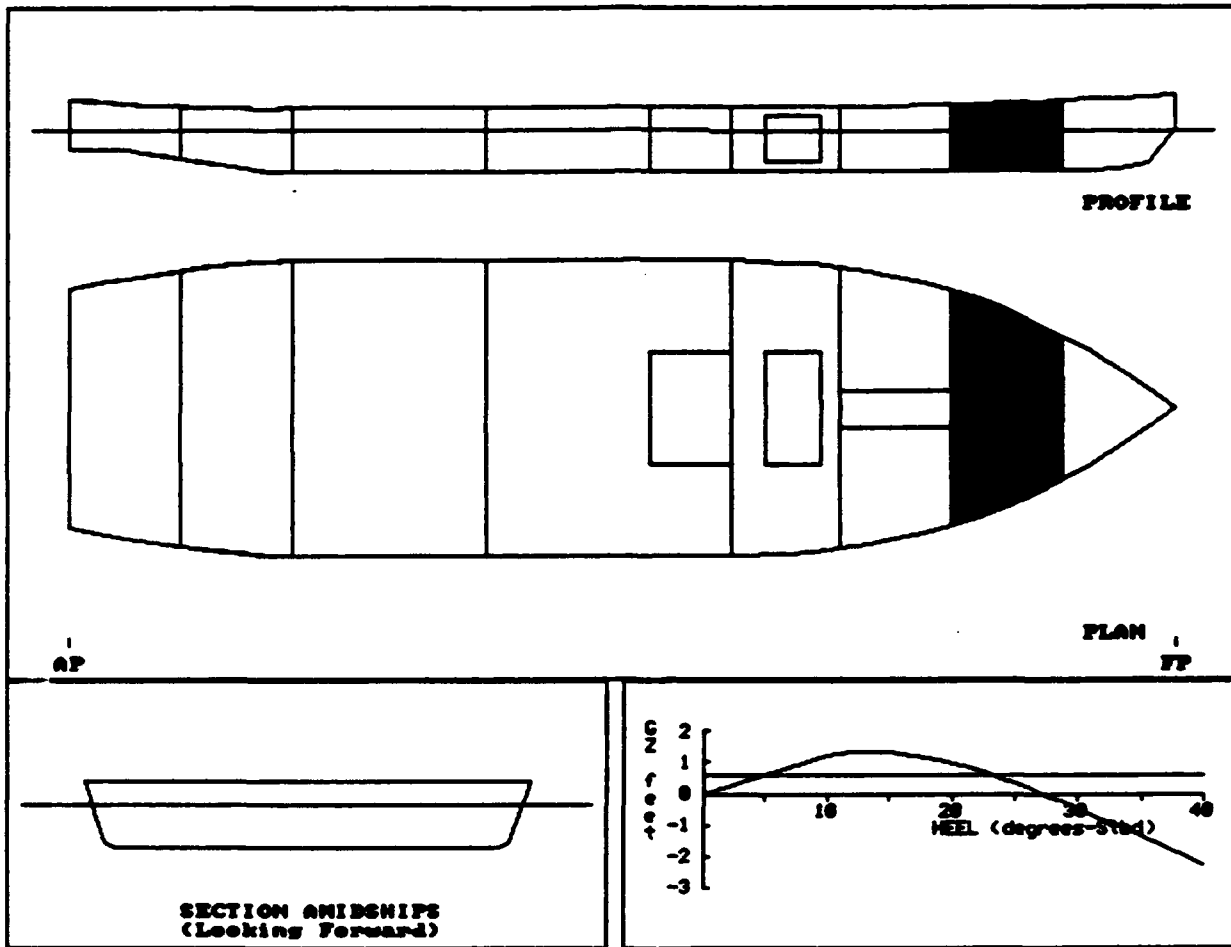

RTRN002A:
 80' PADDLEWHEELR

COMPARTMENT FLOODING SUMMARY

At 0.0o Heel	PERM.	FLOODED WTR LTons	% FULL (Damaged)	% FULL (Intact)	SP.VOL. ft3/LT	OUTFLOW LTons
TANKS	0.95	9	FREE	0.0	----	----
Totals		9				

INTACT DATA

Draft at AP = 4.980 ft	KMT = 20.717 ft	LCG = 45.407A ft-FP
Draft at FP = 3.700 ft	VCG = 13.690 ft	LCB = 45.587A ft-FP
Displacement = 226 LTons	GMT = 7.027 ft	TCG = 0.000 ft-CL

DRAFT/GZ DATA

HEEL degrees	RIGHTING ARM ft	DRAFT AFT ft	DRAFT FWD ft	FLOODED WATER LTons
0.0	0.000	4.672	4.426	9
5.0S	0.584	4.665	4.405	9
7.0S	0.825	4.654	4.391	9
10.0S	1.188	4.637	4.356	9
15.0S	1.326	4.715	4.442	10
20.0S	0.990	4.966	4.639	10
30.0S	-0.462	5.664	4.979	11
40.0S	-2.240	6.627	5.233	11

Note: Drafts are measured at A.P. and F.P along ship's centerline

GZ SUMMARY (Evaluated per IMO (SOLAS'90) Rules for Passenger Ships)
 Available Required

Static Heel Angle	0.0 deg	7.0 deg
Angle at Maximum GZ	15.0S deg	
Maximum GZ	1.345 ft	0.570 ft
Range of Positive GZ	27.2 deg	15.0 deg
Gmt (upright damaged)	6.630 ft	
Righting Area (0.0-22.0)	20.14 ft-deg	2.82 ft-deg

RTRM003A:
 80' PADDLEWHEELR

Imaged Compartments:
 FOREPEAK TANKS

	DISPLACEMENT LTons	DRAFT AFT ft	DRAFT FWD ft	TRIM ft	HEEL deg.	UPRIGHT GMT ft
INTACT	226	4.980	3.700	1.280A	0.0	7.027
DAMAGED	240	4.470	4.858	0.388F	0.0	6.672

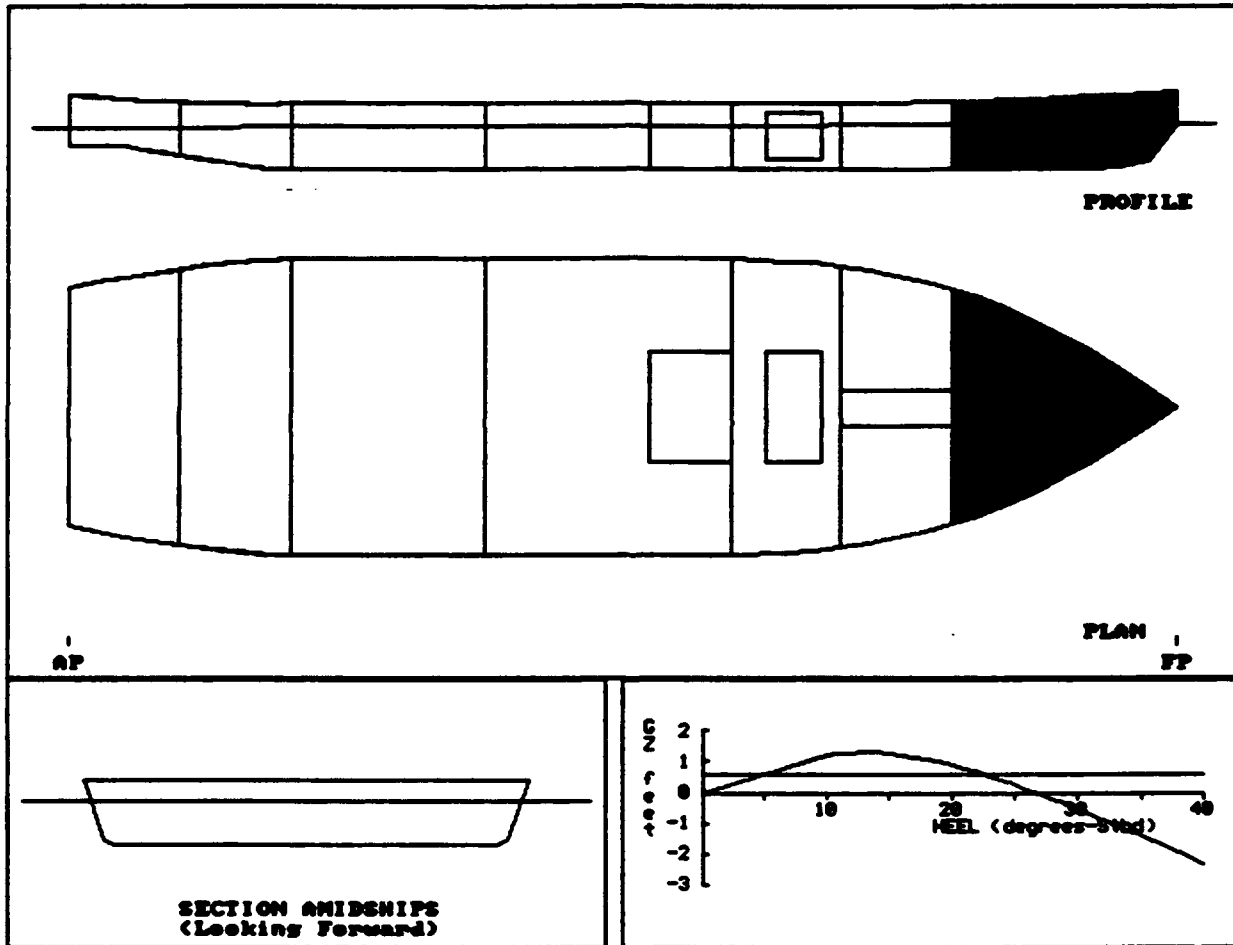

RTRN003A:
 80' PADDLEWHEELR

COMPARTMENT FLOODING SUMMARY

At 0.0o Heel	PERM.	FLOODED WTR LTons	% FULL (Damaged)	% FULL (Intact)	SP.VOL. ft3/LT	OUTFLOW LTons
FOREPEAK	0.95	4	FREE	0.0	----	----
TANKS	0.95	10	FREE	0.0	----	----
Totals		14				

INTACT DATA

Draft at AP = 4.980 ft	KMt = 20.717 ft	LCG = 45.407A ft-FP
Draft at FP = 3.700 ft	VCG = 13.690 ft	LCB = 45.587A ft-FP
Displacement = 226 LTons	GMT = 7.027 ft	TCG = 0.000 ft-CL

DRAFT/GZ DATA

HEEL degrees	RIGHTING ARM ft	DRAFT AFT ft	DRAFT FWD ft	FLOODED WATER LTons
0.0	0.000	4.470	4.858	14
5.0S	0.588	4.460	4.839	14
7.0S	0.830	4.450	4.824	14
10.0S	1.187	4.428	4.798	14
15.0S	1.280	4.438	5.015	15
20.0S	0.920	4.545	5.460	16
30.0S	-0.538	4.840	6.515	18
40.0S	-2.314	5.185	7.807	19

Note: Drafts are measured at A.P. and F.P along ship's centerline

GZ SUMMARY (Evaluated per IMO (SOLAS'90) Rules for Passenger Ships)
 Available Required

Static Heel Angle	0.0 deg	7.0 deg
Angle at Maximum GZ	14.0S deg	
Maximum GZ	1.316 ft	0.570 ft
Range of Positive GZ	26.8 deg	15.0 deg
Gmt (upright damaged)	6.672 ft	
Righting Area (0.0-22.0)	19.60 ft-deg	2.82 ft-deg

RTRN004A:
 80' PADDLEWHEELR

Damaged Compartments:

TANKS FO TANK 1

	DISPLACEMENT LTons	DRAFT AFT ft	DRAFT FWD ft	TRIM ft	HEEL deg.	UPRIGHT GMT ft
INTACT	226	4.980	3.700	1.280A	0.0	7.027
DAMAGED	239	4.529	4.760	0.232F	0.0	6.720

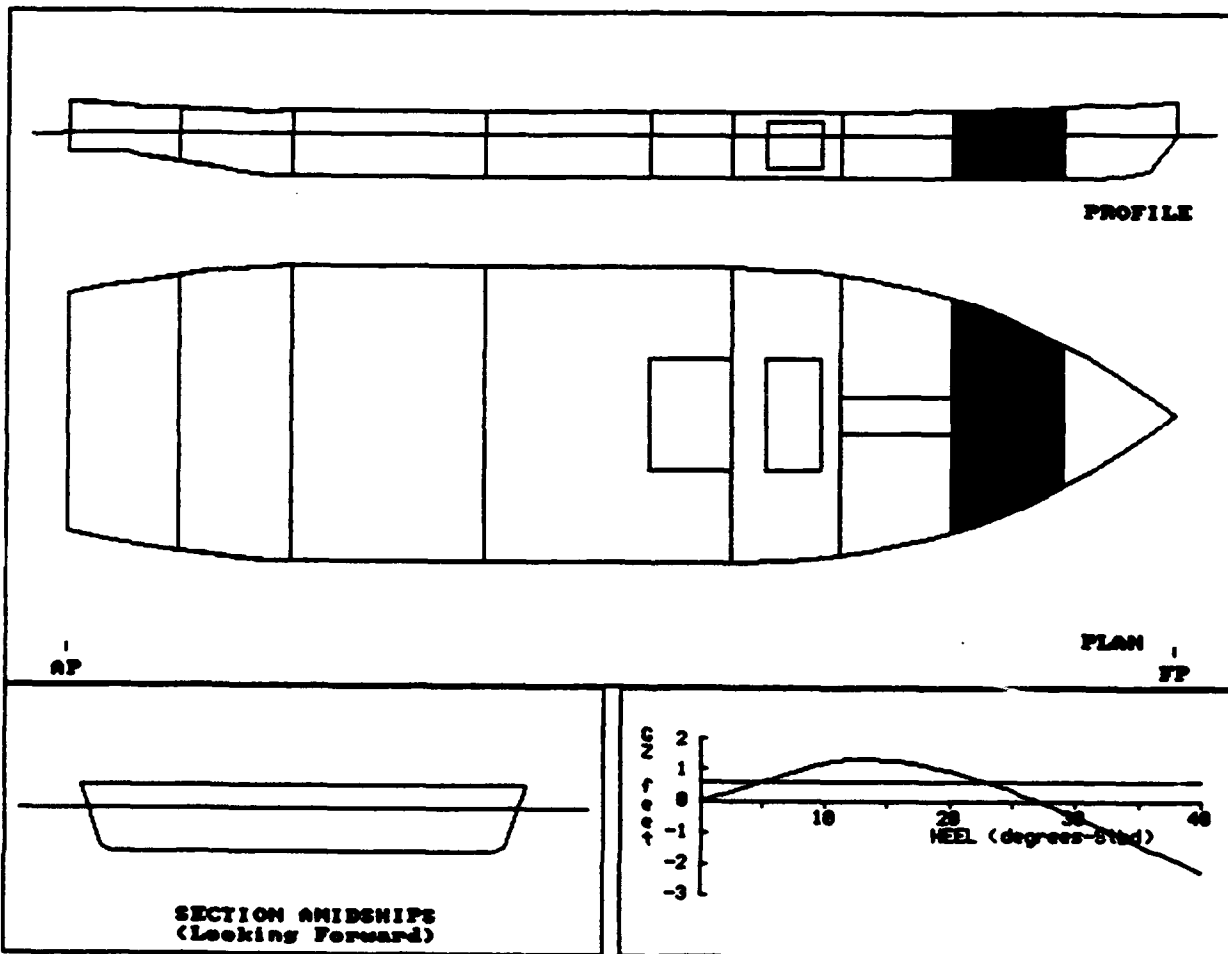

RTRN004A:
 80' PADDLEWHEELR

COMPARTMENT FLOODING SUMMARY

At 0.0o Heel	PERM.	FLOODED WTR LTons	% FULL (Damaged)	% FULL (Intact)	SP.VOL. ft3/LT	OUTFLOW LTons
TANKS	0.95	10	FREE	0.0	----	----
FO TANK 1	0.95	4	FREE	10.0	40.6000	1
Totals		14				1

INTACT DATA

Draft at AP = 4.980 ft KMt = 20.717 ft LCG = 45.407A ft-FP
 Draft at FP = 3.700 ft VCG = 13.690 ft LCB = 45.587A ft-FP
 Displacement = 226 LTons GMT = 7.027 ft TCG = 0.000 ft-CL

DRAFT/GZ DATA

HEEL degrees	RIGHTING ARM ft	DRAFT AFT ft	DRAFT FWD ft	FLOODED WATER LTons
0.0	0.000	4.529	4.760	14
5.0S	0.592	4.520	4.740	14
7.0S	0.836	4.510	4.725	14
10.0S	1.197	4.490	4.695	14
15.0S	1.303	4.530	4.860	14
20.0S	0.956	4.703	5.197	16
30.0S	-0.491	5.215	5.903	17
40.0S	-2.268	5.884	6.701	17

Note: Drafts are measured at A.P. and F.P along ship's centerline

GZ SUMMARY (Evaluated per IMO (SOLAS'90) Rules for Passenger Ships)
 Available Required

Static Heel Angle	0.0 deg	7.0 deg
Angle at Maximum GZ	14.0S deg	
Maximum GZ	1.333 ft	0.570 ft
Range of Positive GZ	27.1 deg	15.0 deg
Gmt (upright damaged)	6.720 ft	
Righting Area (0.0-22.0)	19.95 ft-deg	2.82 ft-deg

RTRN005A:
 80' PADDLEWHEELR

Damaged Compartments:

FOREPEAK

TANKS

FO TANK 1

	DISPLACEMENT LTons	DRAFT AFT ft	DRAFT FWD ft	TRIM ft	HEEL deg.	UPRIGHT GMT ft
INTACT	226	4.980	3.700	1.280A	0.0	7.027
DAMAGED	245	4.284	5.286	1.003F	0.0	6.779

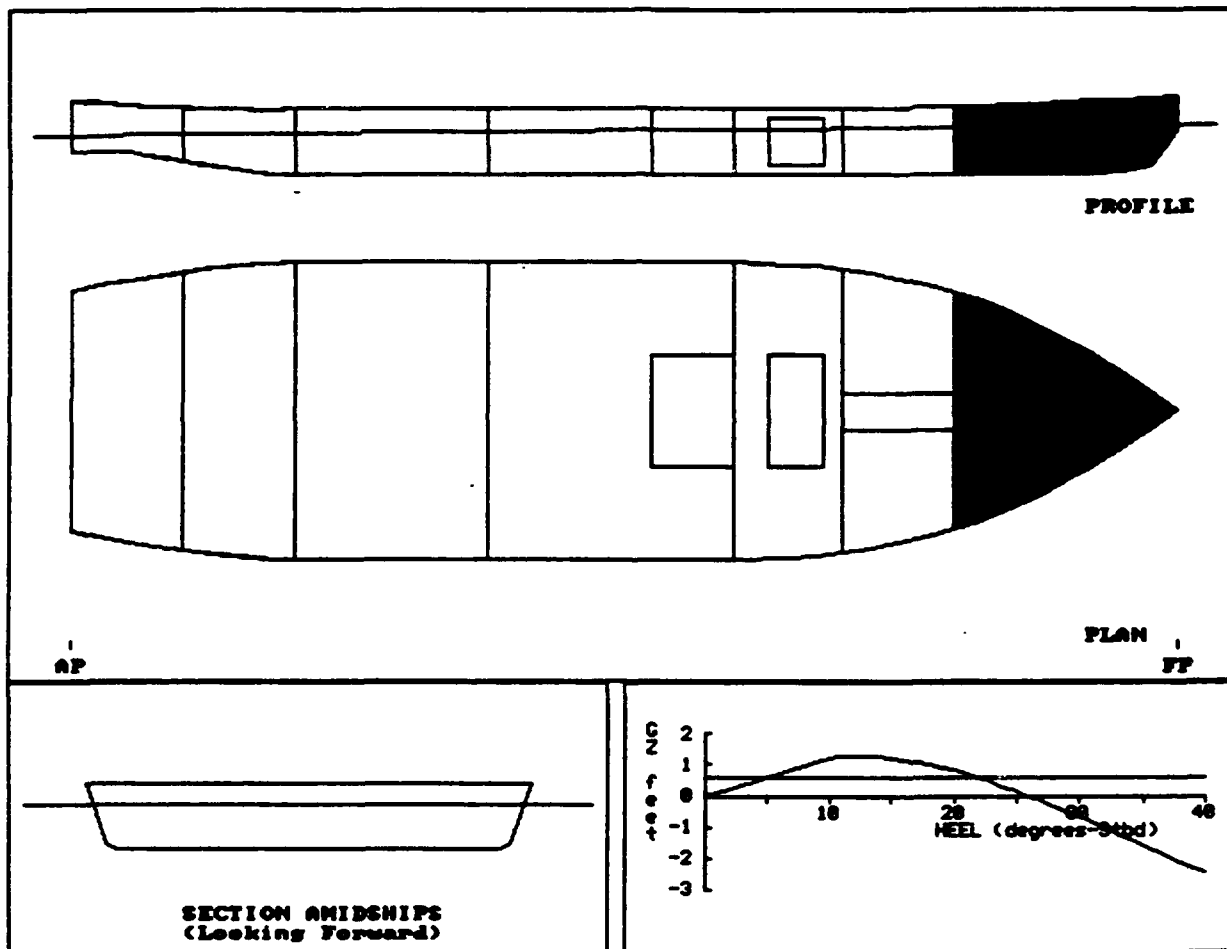

RTRN005A:
 80' PADDLEWHEELR

COMPARTMENT FLOODING SUMMARY

At 0.0o Heel	PERM.	FLOODED WTR LTons	% FULL (Damaged)	% FULL (Intact)	SP.VOL. ft ³ /LT	OUTFLOW LTons
FOREPEAK	0.95	4	FREE	0.0	----	----
TANKS	0.95	11	FREE	0.0	----	----
FO TANK 1	0.95	4	FREE	10.0	40.6000	1
Totals		19				1

INTACT DATA

Draft at AP = 4.980 ft	KMT = 20.717 ft	LCG = 45.407A ft-FP
Draft at FP = 3.700 ft	VCG = 13.690 ft	LCB = 45.587A ft-FP
Displacement = 226 LTons	GMT = 7.027 ft	TCG = 0.000 ft-CL

DRAFT/GZ DATA

HEEL degrees	RIGHTING ARM ft	DRAFT AFT ft	DRAFT FWD ft	FLOODED WATER LTons
0.0	0.000	4.284	5.286	19
5.0S	0.597	4.271	5.271	19
7.0S	0.843	4.261	5.255	19
10.0S	1.184	4.231	5.251	20
15.0S	1.225	4.172	5.616	21
20.0S	0.828	4.150	6.303	24
30.0S	-0.669	3.945	8.315	28
40.0S	-2.476	3.439	11.155	30

Note: Drafts are measured at A.P. and F.P along ship's centerline

GZ SUMMARY (Evaluated per IMO (SOLAS'90) Rules for Passenger Ships)
 Available Required

Static Heel Angle	0.0 deg	7.0 deg
Angle at Maximum GZ	14.0S deg	
Maximum GZ	1.282 ft	0.570 ft
Range of Positive GZ	26.0 deg	15.0 deg
Gmt (upright damaged)	6.779 ft	
Righting Area (0.0-22.0)	18.95 ft-deg	2.82 ft-deg

RTRN006A:
 80' PADDLEWHEELR

Imaged Compartments:
 TANKS2

	DISPLACEMENT LTons	DRAFT AFT ft	DRAFT FWD ft	TRIM ft	HEEL deg.	UPRIGHT GMT ft
INTACT	226	4.980	3.700	1.280A	0.0	7.027
DAMAGED	246	4.538	5.005	0.467F	0.0	5.907

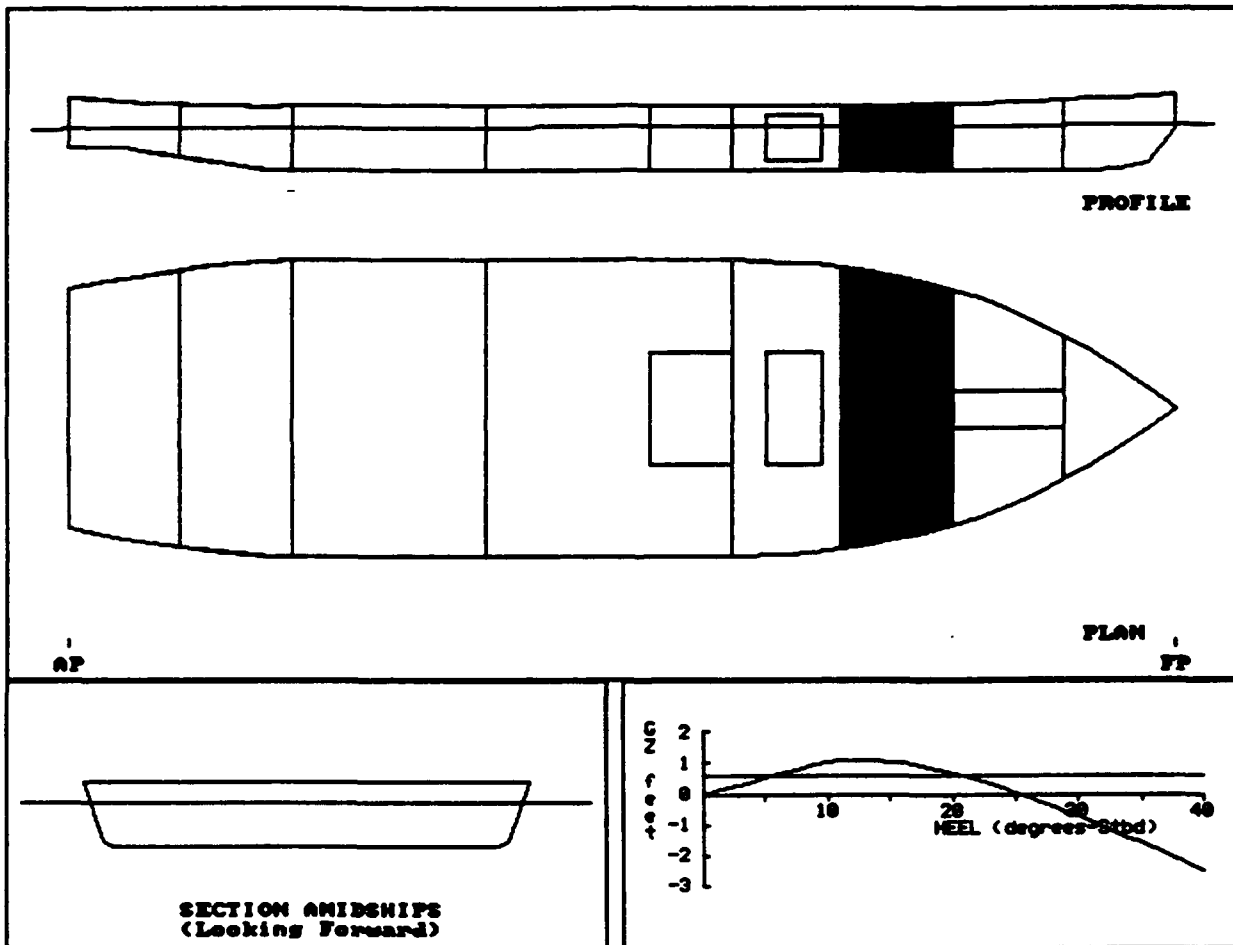

RTRN006A:
 80' PADDLEWHEELR

COMPARTMENT FLOODING SUMMARY

At 0.0o Heel	PERM.	FLOODED WTR LTons	% FULL (Damaged)	% FULL (Intact)	SP.VOL. ft3/LT	OUTFLOW LTons
TANKS2	0.95	20	FREE	0.0	----	----
Totals		20				

INTACT DATA

Draft at AP = 4.980 ft Kmt = 20.717 ft LCG = 45.407A ft-FP
 Draft at FP = 3.700 ft VCG = 13.690 ft LCB = 45.587A ft-FP
 Displacement = 226 LTons Gmt = 7.027 ft TCG = 0.000 ft-CL

DRAFT/GZ DATA

HEEL degrees	RIGHTING ARM ft	DRAFT AFT ft	DRAFT FWD ft	FLOODED WATER LTons
0.0	0.000	4.538	5.005	20
5.0S	0.521	4.531	4.985	20
7.0S	0.736	4.519	4.971	20
10.0S	1.035	4.500	4.956	20
15.0S	1.054	4.586	5.086	20
20.0S	0.686	4.845	5.313	20
30.0S	-0.739	5.581	5.775	19
40.0S	-2.478	6.549	6.237	18

Note: Drafts are measured at A.P. and F.P along ship's centerline

GZ SUMMARY (Evaluated per IMO (SOLAS'90) Rules for Passenger Ships)
 Available Required

Static Heel Angle	0.0 deg	7.0 deg
Angle at Maximum GZ	13.0S deg	
Maximum GZ	1.113 ft	0.570 ft
Range of Positive GZ	25.4 deg	15.0 deg
Gmt (upright damaged)	5.907 ft	
Righting Area (0.0-22.0)	16.31 ft-deg	2.82 ft-deg

RTRN007A:
 80' PADDLEWHEELR

Damaged Compartments:
 COMPT 3

	DISPLACEMENT LTons	DRAFT AFT ft	DRAFT FWD ft	TRIM ft	HEEL deg.	UPRIGHT GMT ft
INTACT	226	4.980	3.700	1.280A	0.0	7.027
DAMAGED	252	4.733	4.965	0.232F	0.0	5.417

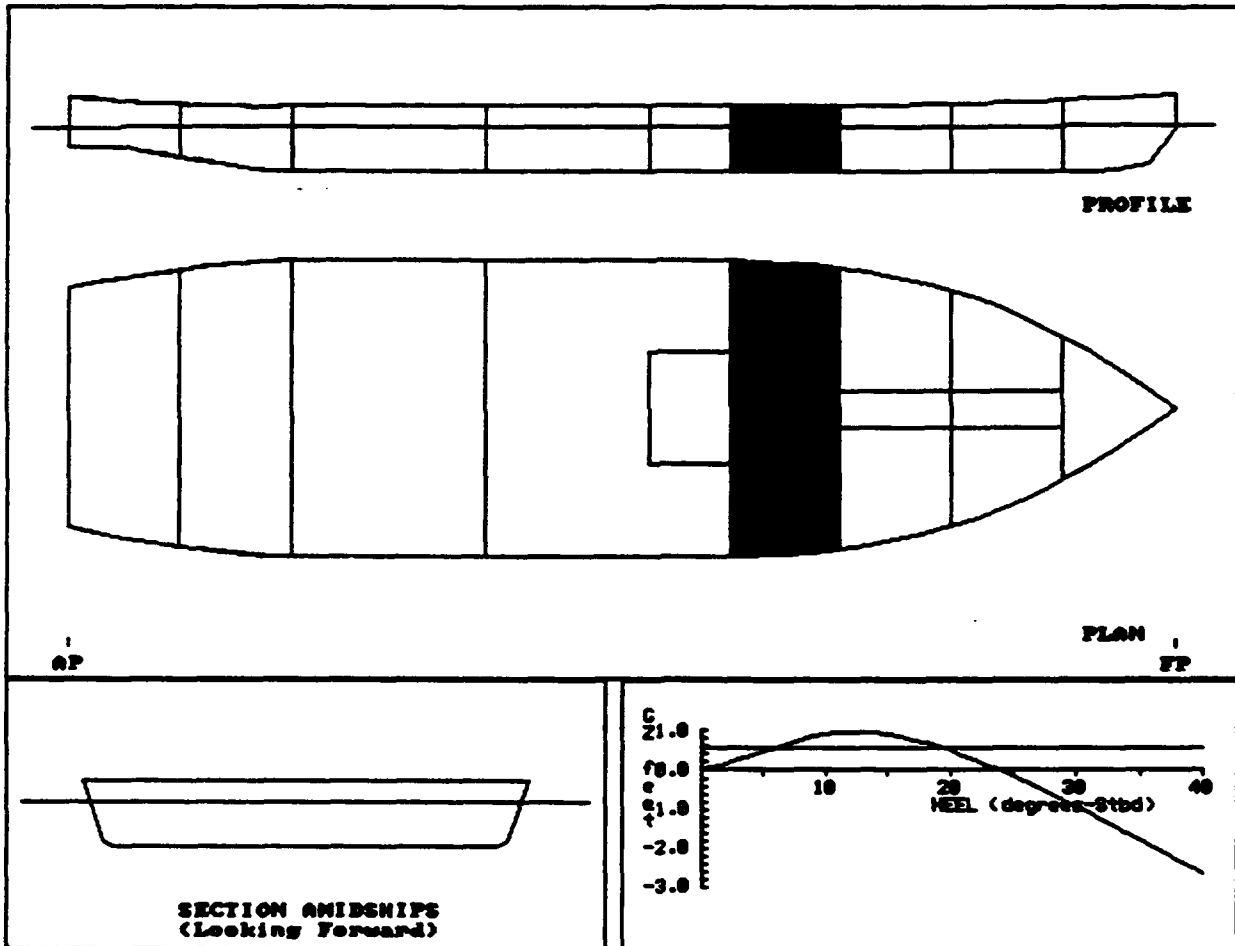

RTRN007A:
 80' PADDLEWHEELR

COMPARTMENT FLOODING SUMMARY

At 0.0o Heel	PERM.	FLOODED WTR LTons	% FULL (Damaged)	% FULL (Intact)	SP.VOL. ft3/LT	OUTFLOW LTons
COMPT 3	0.95	25	FREE	0.0	----	----
Totals		25				

INTACT DATA

Draft at AP = 4.980 ft KMT = 20.717 ft LCG = 45.407A ft-FP
 Draft at FP = 3.700 ft VCG = 13.690 ft LCB = 45.587A ft-FP
 Displacement = 226 LTons GMT = 7.027 ft TCG = 0.000 ft-CL

DRAFT/GZ DATA

HEEL degrees	RIGHTING ARM ft	DRAFT AFT ft	DRAFT FWD ft	FLOODED WATER LTons
0.0	0.000	4.733	4.965	25
5.0S	0.478	4.730	4.938	25
7.0S	0.676	4.720	4.921	25
10.0S	0.936	4.713	4.899	25
15.0S	0.903	4.870	4.962	25
20.0S	0.502	5.224	5.108	24
30.0S	-0.923	6.161	5.476	23
40.0S	-2.645	7.368	5.880	23

Note: Drafts are measured at A.P. and F.P along ship's centerline

GZ SUMMARY (Evaluated per IMO (SOLAS'90) Rules for Passenger Ships)
 Available Required

Static Heel Angle	0.0 deg	7.0 deg
Angle at Maximum GZ	13.0S deg	
Maximum GZ	0.990 ft	0.570 ft
Range of Positive GZ	24.0 deg	15.0 deg
Gmt (upright damaged)	5.417 ft	
Righting Area (0.0-22.0)	14.00 ft-deg	2.82 ft-deg

RTRN008A:
80' PADDLEWHEELR

Imaged Compartments:
 COMPT 4

	DISPLACEMENT LTons	DRAFT AFT ft	DRAFT FWD ft	TRIM ft	HEEL deg.	UPRIGHT Gmt ft
INTACT	226	4.980	3.700	1.280A	0.0	7.027
DAMAGED	298	5.852	5.267	0.585A	0.0	3.267

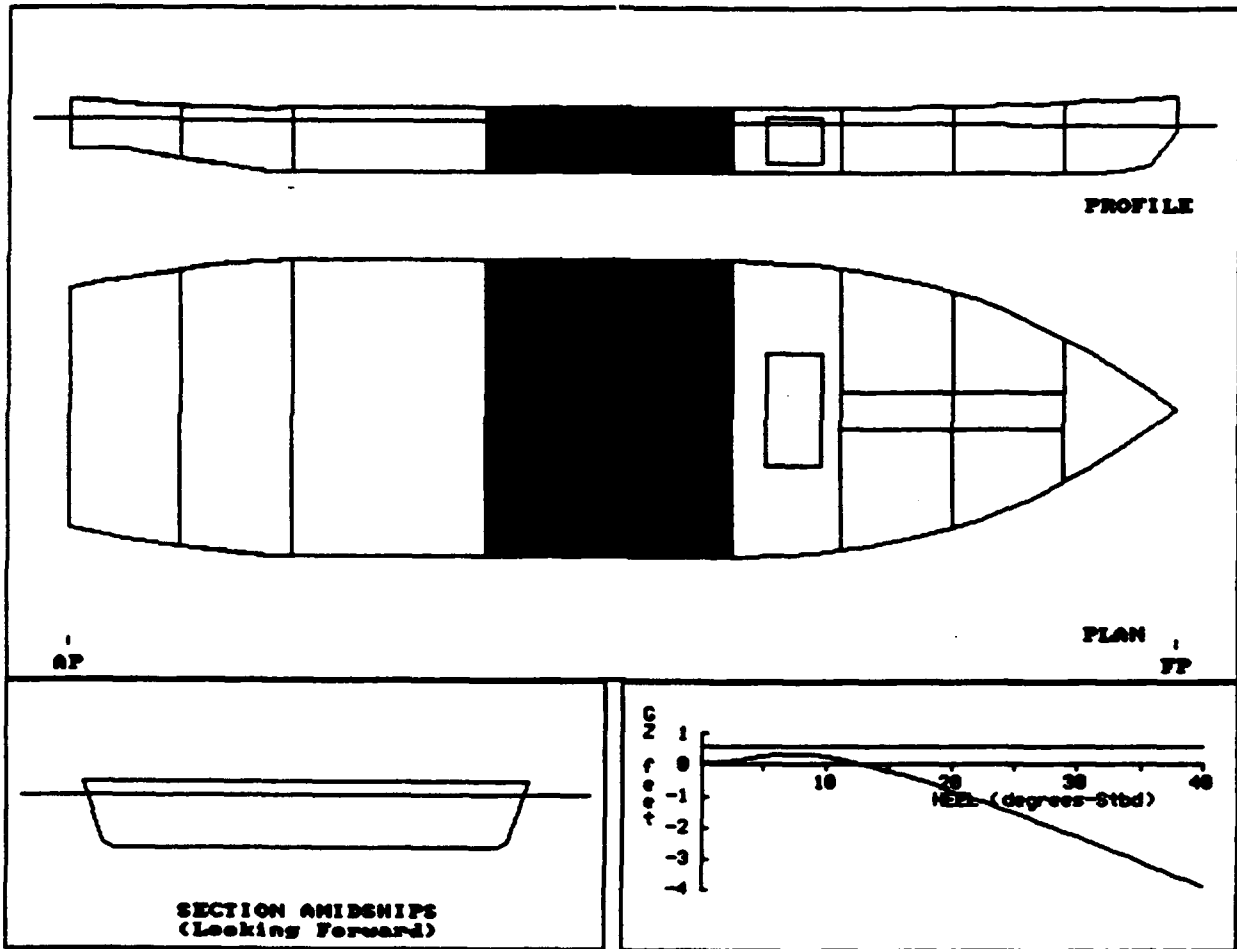

RTRN009A:
 80' PADDLEWHEELR

aged Compartments:
 ENGINE ROOM

	DISPLACEMENT LTons	DRAFT AFT ft	DRAFT FWD ft	TRIM ft	HEEL deg.	UPRIGHT GMT ft
INTACT	226	4.980	3.700	1.280A	0.0	7.027
DAMAGED	288	7.209	3.200	4.009A	0.0	4.523

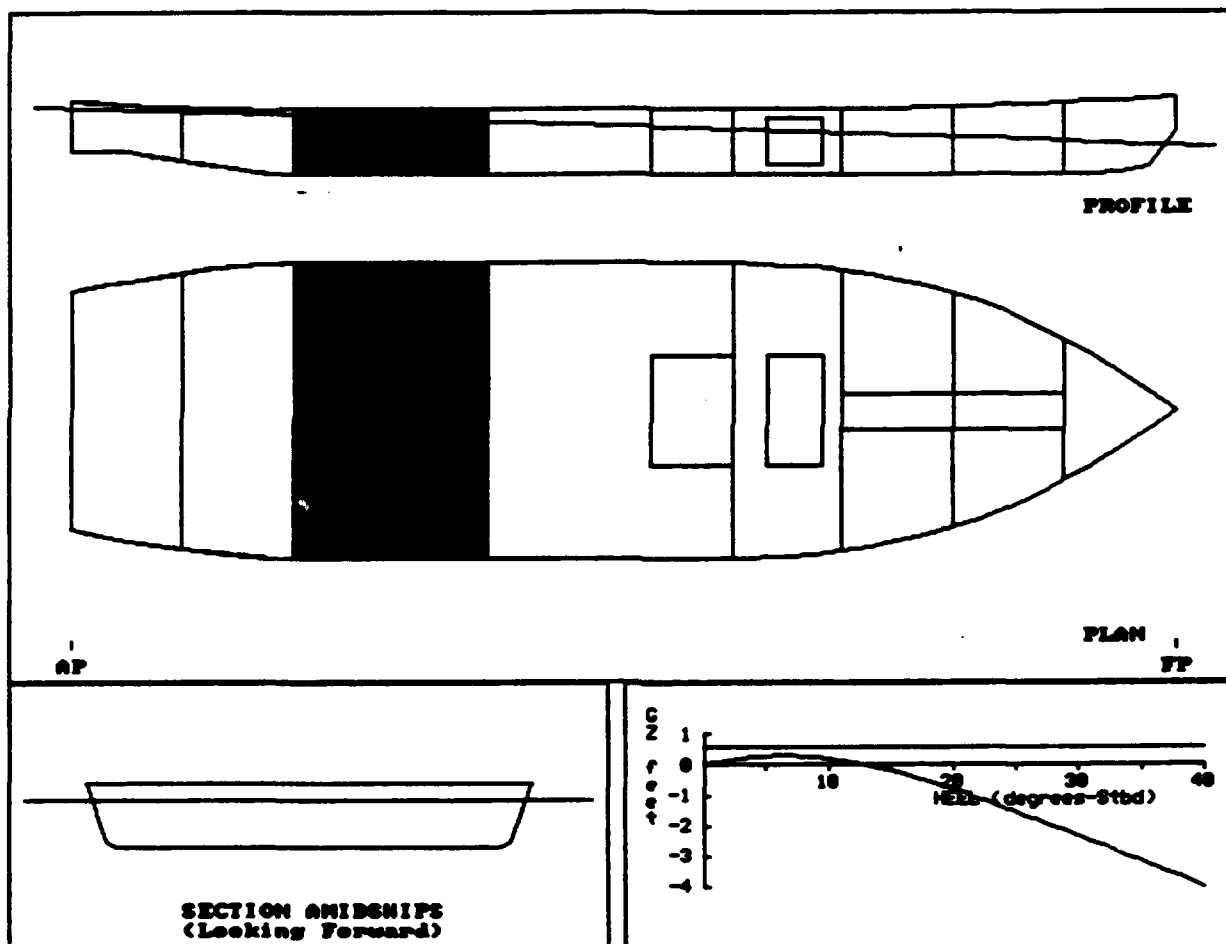

RTRN010A:
 80' PADDLEWHEELR

Imaged Compartments:
 COMPT 6

	DISPLACEMENT LTons	DRAFT AFT ft	DRAFT FWD ft	TRIM ft	HEEL deg.	UPRIGHT GMT ft
INTACT	226	4.980	3.700	1.280A	0.0	7.027
DAMAGED	263	6.911	2.604	4.307A	0.0	5.430

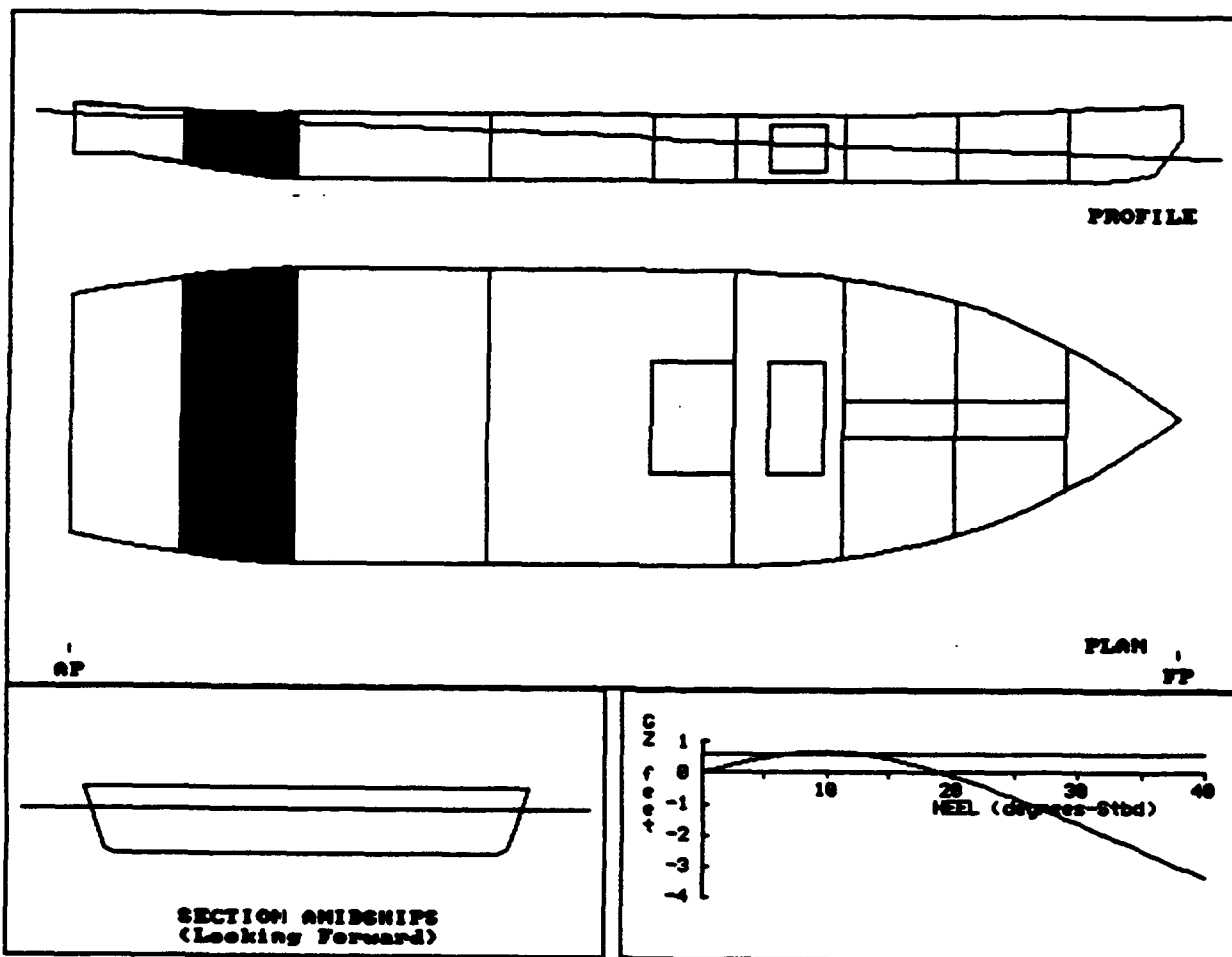

RTRN010A:
 80' PADDLEWHEELR

COMPARTMENT FLOODING SUMMARY

At 0.0o Heel	PERM.	FLOODED WTR LTons	% FULL (Damaged)	% FULL (Intact)	SP.VOL. ft ³ /LT	OUTFLOW LTons
COMPT 6	0.95	36	FREE	0.0	----	----
Totals		36				

INTACT DATA

Draft at AP = 4.980 ft	KMt = 20.717 ft	LCG = 45.407A ft-FP
Draft at FP = 3.700 ft	VCG = 13.690 ft	LCB = 45.587A ft-FP
Displacement = 226 LTons	GMT = 7.027 ft	TCG = 0.000 ft-CL

DRAFT/GZ DATA

HEEL degrees	RIGHTING ARM ft	DRAFT AFT ft	DRAFT FWD ft	FLOODED WATER LTons
0.0	0.000	6.911	2.604	36
5.0S	0.463	6.934	2.562	36
7.0S	0.595	7.007	2.500	36
10.0S	0.670	7.268	2.329	35
15.0S	0.450	8.075	1.917	35
20.0S	-0.082	9.240	1.379	36
30.0S	-1.614	12.408	-0.118	37
40.0S	-3.339	16.811	-2.344	38

Note: Drafts are measured at A.P. and F.P along ship's centerline

GZ SUMMARY (Evaluated per IMO (SOLAS'90) Rules for Passenger Ships)

	Available	Required
Static Heel Angle	0.0 deg	7.0 deg
Angle at Maximum GZ	11.0S deg	
Maximum GZ	0.670 ft	0.570 ft
Range of Positive GZ	19.3 deg	15.0 deg
Gmt (upright damaged)	5.430 ft	
Righting Area (0.0-19.3)	8.19 ft-deg	2.82 ft-deg

RTRN011A:
 80' PADDLEWHEELR

aged Compartments:
 COMPT 7

	DISPLACEMENT LTons	DRAFT AFT ft	DRAFT FWD ft	TRIM ft	HEEL deg.	UPRIGHT GMT ft
INTACT	226	4.980	3.700	1.280A	0.0	7.027
DAMAGED	250	6.513	2.616	3.897A	0.0	5.719

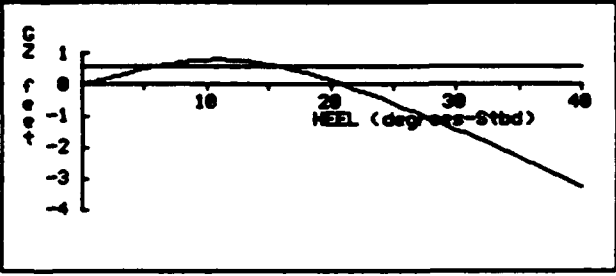
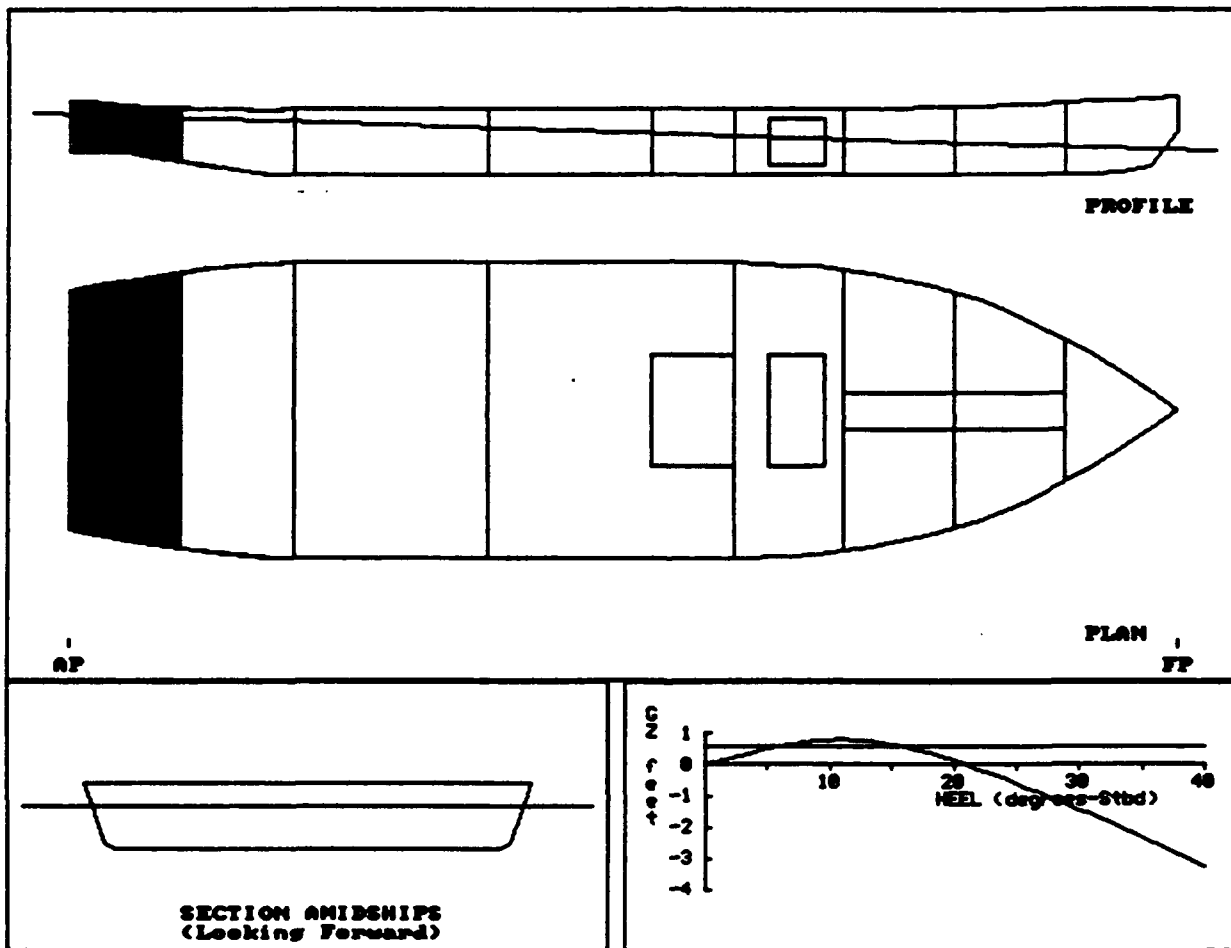

RTRN011A:
 80' PADDLEWHEELR

COMPARTMENT FLOODING SUMMARY

At 0.0o Heel	PERM.	FLOODED WTR LTons	% FULL (Damaged)	% FULL (Intact)	SP.VOL. ft3/LT	OUTFLOW LTons
COMPT 7	0.95	23	FREE	0.0	----	----
Totals		23				

INTACT DATA

Draft at AP = 4.980 ft	Kmt = 20.717 ft	LCG = 45.407A ft-FP
Draft at FP = 3.700 ft	VCG = 13.690 ft	LCB = 45.587A ft-FP
Displacement = 226 LTons	Gmt = 7.027 ft	TCG = 0.000 ft-CL

DRAFT/GZ DATA

HEEL degrees	RIGHTING ARM ft	DRAFT AFT ft	DRAFT FWD ft	FLOODED WATER LTons
0.0	0.000	6.513	2.616	23
5.0S	0.500	6.525	2.577	23
7.0S	0.668	6.556	2.542	23
10.0S	0.803	6.773	2.379	24
15.0S	0.654	7.539	1.937	24
20.0S	0.138	8.708	1.322	26
30.0S	-1.435	11.935	-0.432	28
40.0S	-3.231	16.459	-3.062	29

Note: Drafts are measured at A.P. and F.P. along ship's centerline

GZ SUMMARY (Evaluated per IMO (SOLAS'90) Rules for Passenger Ships)

	Available	Required
Static Heel Angle	0.0 deg	7.0 deg
Angle at Maximum GZ	12.0S deg	
Maximum GZ	0.809 ft	0.570 ft
Range of Positive GZ	21.0 deg	15.0 deg
Gmt (upright damaged)	5.719 ft	
Righting Area (0.0-21.0)	10.66 ft-deg	2.82 ft-deg

**APPENDIX B
HYDROSTATICS AND
DAMAGE STABILITY
OUTPUT**

198' CASINO BOAT

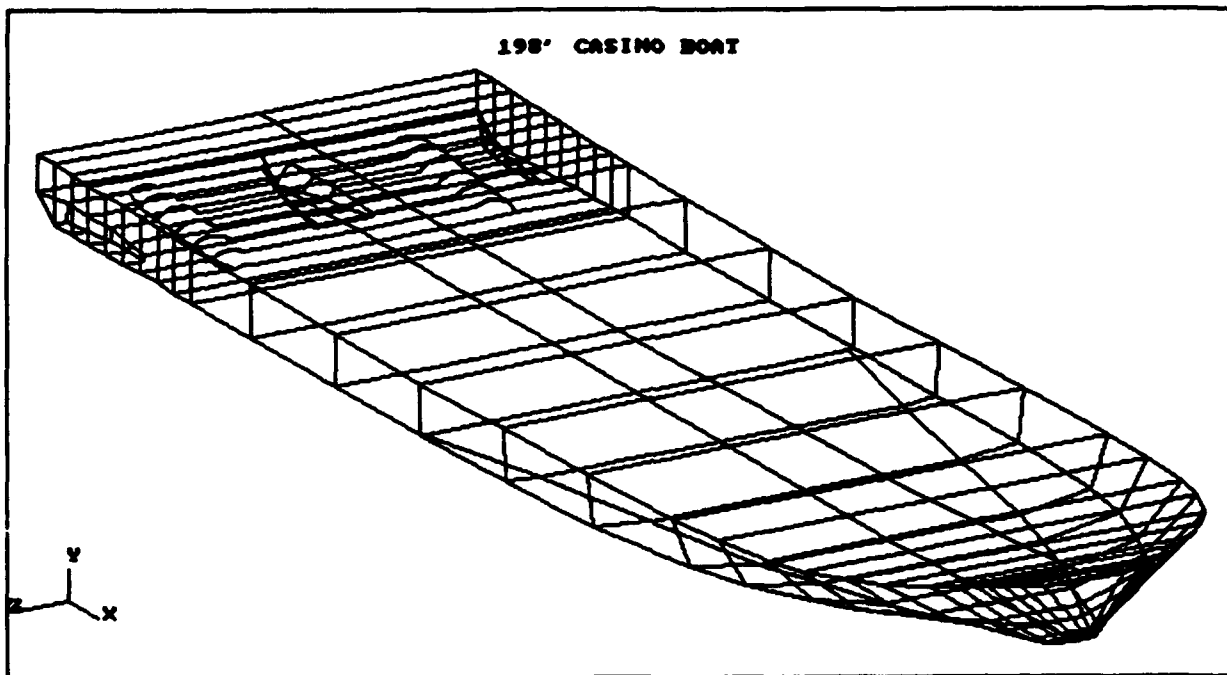

DAMAGE STABILITY SUMMARY
CASINO '98'

CASE No.	FILE NAME	DAMAGED COMP.	LISTING	Intact Condition			Equilibrium Condition After Damage			SURVIVAL			
				W.DRAFT (ft)	VCG (ft)	GNT (ft)	HEEL (deg)	MAX.GZ (ft)	RANGE (deg)		AREA (ft-deg)	DAM.GNT (ft)	DOWNFLD (ft)
1	RTRN001A	1,2		6.280	28.400	23.932	0.0	4.073	27.77	61.28	22.230	5.010	Yes
2	RTRN002A	2,3		6.280	28.400	23.932	0.0	3.125	25.21	46.40	19.143	3.879	Yes
3	RTRN003A	3,4		6.280	28.400	23.932	0.0	2.334	22.55	32.85	16.382	2.977	Yes
4	RTRN004A	4,5		6.280	28.400	23.932	0.0	2.004	21.29	26.80	14.775	3.098	Yes
5	RTRN005A	5,6		6.280	28.400	23.932	0.0	1.939	21.06	25.09	13.284	3.946	Yes
6	RTRN006A	6,7		6.280	28.400	23.932	1.1P	2.740	23.36	37.77	-----	5.205	Yes
7	RTRN007A	6,9		6.280	28.400	23.932	1.18	2.740	23.36	37.77	-----	4.057	Yes
8	RTRN008A	7,10		6.280	28.400	23.932	0.58	3.855	27.52	56.46	-----	4.946	Yes
9	RTRN009A	9,12		6.280	28.400	23.932	0.5P	3.855	27.52	56.46	-----	5.470	Yes
10	RTRN010A	10,13		6.280	28.400	23.932	2.18	2.466	22.20	33.19	-----	2.725	Yes
11	RTRN011A	12,13		6.280	28.400	23.932	2.1P	2.466	22.20	33.16	-----	4.894	Yes
12	RTRN012A	13,14		6.280	28.400	23.932	0.0	2.046	21.36	27.66	15.934	2.275	Yes
13	RTRN013A	14,15		6.280	28.400	23.932	0.0	2.147	21.60	29.08	15.798	2.692	Yes
14	RTRN014A	4,5		6.280	28.400	23.932	0.0	2.004	21.29	26.80	14.775	3.098	Yes
15	RTRN015A	11,8		6.280	28.400	23.932	0.0	4.197	28.62	64.15	22.605	4.363	Yes
16	RTRN016A	11,13		6.280	28.400	23.932	0.0	3.125	25.57	46.83	19.222	3.383	Yes
17	RTRN017A	10,11		6.280	28.400	23.932	1.68	3.324	25.17	47.06	-----	3.583	Yes
18	RTRN018A	11,12,13		6.280	28.400	23.932	2.3P	1.825	19.13	22.05	-----	4.163	Yes

DAMAGE STABILITY SUMMARY
 CASINO 1981

CASE No.	FILE NAME	DAMAGED COMP. LISTING	Intact Condition			HEEL (deg)	Equilibrium Condition After Damage			SURVIVAL		
			MIN DRAFT (ft)	VCG (ft)	GHT (ft)		MAX GZ (deg)	AREA (ft-deg)	DAM GHT (ft)		DOWNFLD (ft)	
1	DPT0018	1,2	6.470	27.800	23.119	0.0	3.849	27.37	57.90	21.593	4.766	Yes
2	DPT0028	2,3	6.470	27.800	23.119	0.0	2.902	24.68	42.91	18.686	3.612	Yes
3	DPT0038	3,4	6.470	27.800	23.119	0.0	2.115	21.82	29.20	16.103	2.699	Yes
4	DPT0048	4,5	6.470	27.800	23.119	0.0	1.807	20.46	23.45	14.372	2.823	Yes
5	DPT0058	5,6	6.470	27.800	23.119	0.0	1.757	20.17	21.78	12.926	3.692	Yes
6	DPT0068	6,7	6.470	27.800	23.119	2.18	2.125	21.06	27.61	2.952	Yes
7	DPT0078	6,9	6.470	27.800	23.119	2.1P	2.124	21.06	27.60	5.157	Yes
8	DPT0088	7,10	6.470	27.800	23.119	0.58	3.724	27.46	54.61	4.856	Yes
9	DPT0098	9,12	6.470	27.800	23.119	0.5P	3.723	27.46	54.62	5.350	Yes
10	DPT0108	10,13	6.470	27.800	23.119	0.96	2.924	24.26	41.37	4.574	Yes
11	DPT0118	12,13	6.470	27.800	23.119	0.0	2.924	24.26	41.36	3.613	Yes
12	DPT0128	13,14	6.470	27.800	23.119	0.0	1.808	20.29	23.43	15.419	1.986	Yes
13	DPT0138	14,15	6.470	27.800	23.119	0.0	1.901	20.59	24.77	15.265	2.353	Yes
14	DPT0148	4,5	6.470	27.800	23.119	0.0	1.807	20.46	23.45	14.372	2.823	Yes
15	DPT0158	11,8	6.470	27.800	23.119	0.0	4.522	28.84	68.41	23.370	4.790	Yes
16	DPT0168	11,13	6.470	27.800	23.119	0.0	2.852	24.82	42.42	18.597	3.134	Yes
17	DPT0178	10,11	6.470	27.800	23.119	0.9P	3.655	26.40	52.91	5.165	Yes
18	DPT0188	11,12,13	6.470	27.800	23.119	0.78	2.517	22.82	35.05	2.888	Yes

HYDROSTATIC TABLES
 CASINO, 198'

MOLDED DRAFT (ft)		6.000	6.500	7.000	15.000
DISP.MLD.	(LTons-SW)	1,679.0	1,834.8	1,991.0	3,566.2
DISP.TOTAL	(LTons-SW)	1,697.1	1,853.8	2,011.0	3,604.5
DISP.TOTAL	(LTons-FW)	1,655.4	1,808.3	1,961.6	3,515.9
LCB	(ft-FP)	106.032A	106.208A	106.338A	103.205A
TCB	(ft-CL)	0.000	0.000	0.000	0.000
KB	(ft)	3.150	3.413	3.675	6.296
BMT	(ft)	51.278	47.144	43.651	0.125
KMT	(ft)	54.429	50.558	47.326	6.421
BML	(ft)	530.880	489.446	454.405	0.012
KML	(ft)	534.030	492.859	458.080	6.308
TPI	(LTons)	25.92	26.00	26.08	0.55
MTlin	(ft-LTons)	374.3	377.1	379.9	0.0
CTlin	(LTons)	1.18	1.15	1.12	-0.26
LCF	(ft-FP)	108.250A	108.003A	107.755A	5.803A
W.P. AREA	(ft ²)	10,886.4	10,919.2	10,952.3	232.5
WETTED SUR.	(ft ²)	13,089.1	13,357.5	13,626.3	27,714.2
MAX. BEAM	(ft)	60.000	60.000	60.000	60.000
LENGTH W.L.	(ft)	198.074	198.241	198.400	0.000
Cb		0.8228	0.8299	0.8363	0.6990
Cm		1.0000	1.0000	1.0000	1.0546
Cp		0.8228	0.8299	0.8363	0.6628
Cup		0.9145	0.9173	0.9200	0.0195
Cit		0.8438	0.8477	0.8518	0.0044

Assumes: Sea Water at 35.0000 ft³/LT
 Fresh Water at 35.8814 ft³/LT
 Ship floating at even keel (no heel or trim)

DPR001A: VOID THRUSTER
 198' CASINO BOAT

aged Compartments:
 VOID THRUSTER RM

	DISPLACEMENT LTons	DRAFT AFT ft	DRAFT FWD ft	TRIM ft	HEEL deg.	UPRIGHT GMT ft
INTACT	1,837.5	6.470	6.470	0.000	0.00	23.119
DAMAGED	2,015.7	5.421	8.944	3.523F	0.00	21.593

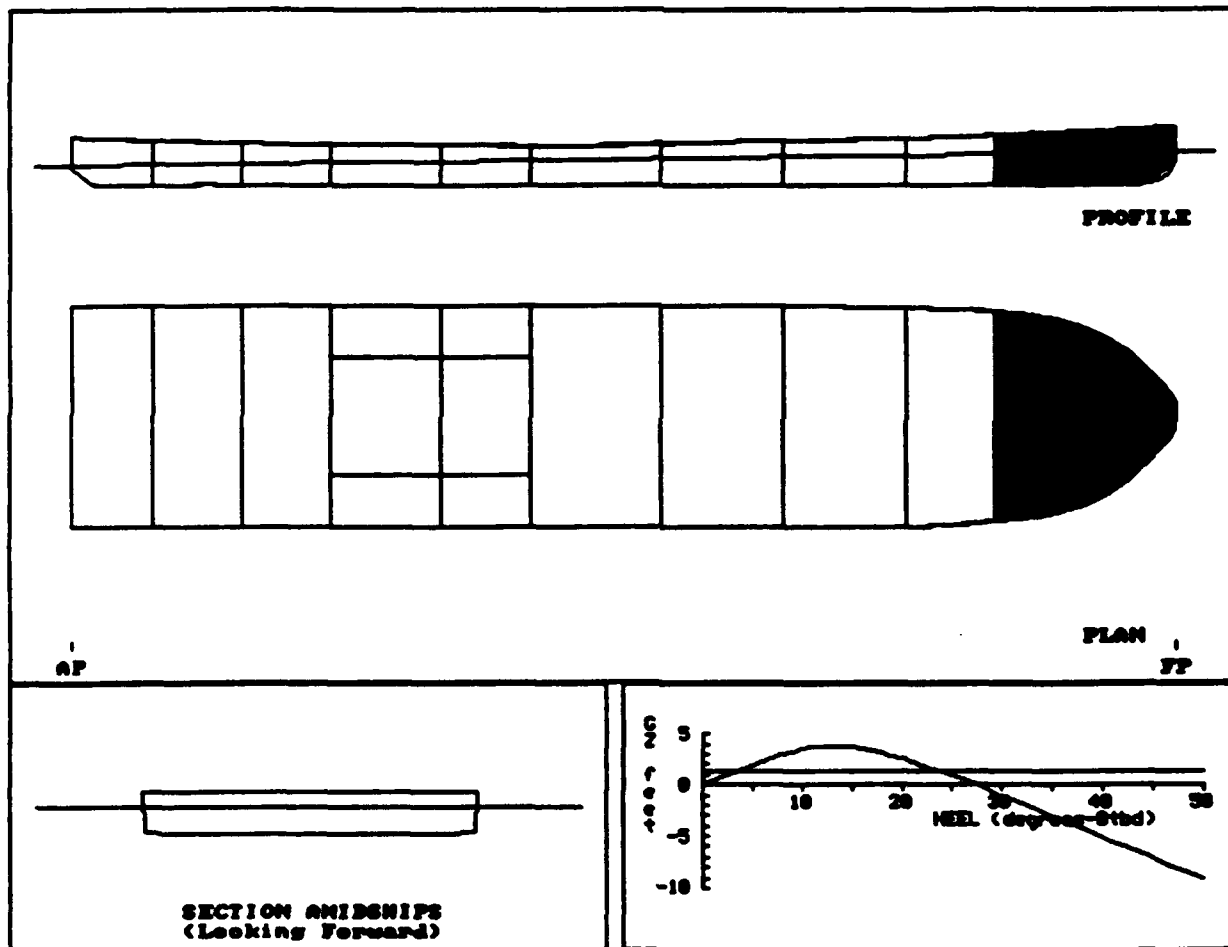

DFRT001A: VOID THRUSTER
 198' CASINO BOAT

COMPARTMENT FLOODING SUMMARY

At 0.0o Heel	PERM.	FLOODED WTR LTons	% FULL (Damaged)	% FULL (Intact)	SP.VOL. ft3/LT	OUTFLOW LTons
VOID	0.95	56.5	FREE	0.0	----	----
THRUSTER RM	0.85	121.6	FREE	0.0	----	----
Totals		178.2				

INTACT DATA

Draft at AP = 6.470 ft	KMt = 50.919 ft	LCG = 106.193A ft-FP
Draft at FP = 6.470 ft	VCG = 27.800 ft	LCB = 106.193A ft-FP
Displacement = 1837.5 LTons	Gmt = 23.119 ft	TCG = 0.000 ft-CL

DRAFT/GZ DATA

HEEL degrees	RIGHTING ARM ft	DRAFT AFT ft	DRAFT FWD ft	FLOODED WATER LTons
0.00	0.000	5.421	8.944	178.2
5.00S	1.851	5.370	8.963	180.0
10.00S	3.529	5.239	9.071	187.1
15.00S	3.729	4.960	9.931	211.5
20.00S	2.584	4.540	11.177	233.5
25.00S	0.892	4.028	12.642	249.9
30.00S	-1.027	3.400	14.345	262.4
35.00S	-3.040	2.696	16.265	271.6
40.00S	-5.083	1.897	18.463	278.8
50.00S	-9.120	-0.074	24.013	288.6

Note: Drafts are measured at A.P. and F.P along ship's centerline

GZ SUMMARY (Evaluated per IMO (SOLAS'90) Rules for Passenger Ships)
 Available Required

Static Heel Angle	0.00 deg	7.00 deg
Freeboard to Downflooding	4.766 ft	
Angle at Maximum GZ	14.00S deg	
Maximum GZ	3.849 ft	1.340 ft
Range of Positive GZ	27.37 deg	15.00 deg
Gmt (upright damaged)	21.593 ft	
Righting Area (0.00-1.00)	57.900 ft-deg	2.820 ft-deg

DPRT002A: THRUSTER STOR1
 198' CASINO BOAT

Damaged Compartments:
 THRUSTER RM STORAGE

	DISPLACEMENT LTons	DRAFT AFT ft	DRAFT FWD ft	TRIM ft	HEEL deg.	UPRIGHT GNT ft
INTACT	1,837.5	6.470	6.470	0.000	0.00	23.119
DAMAGED	2,194.5	4.883	10.776	5.893F	0.00	18.686

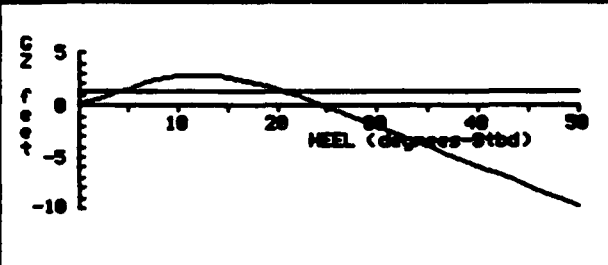
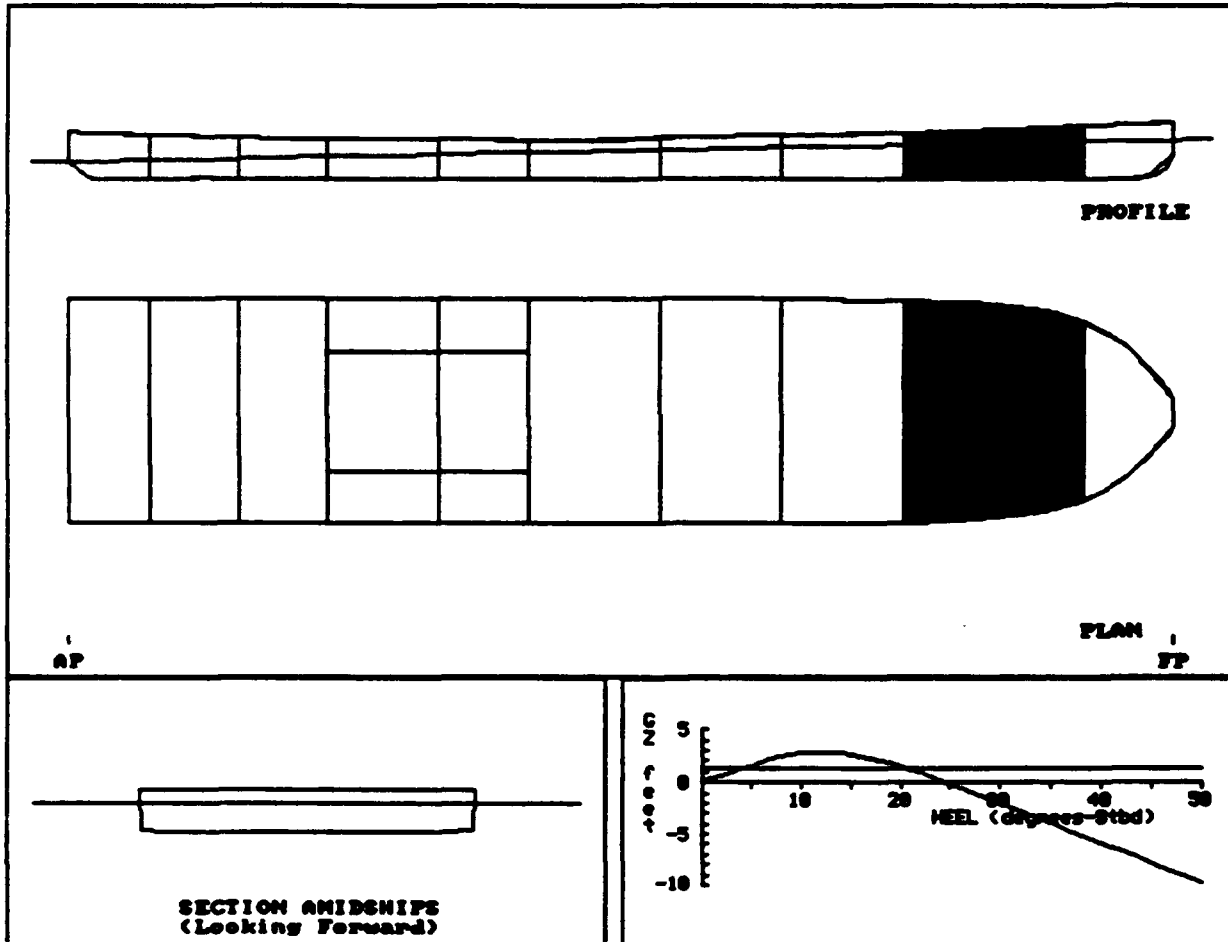

DPRT002A: THRUSTER STOR1
 198' CASINO BOAT

COMPARTMENT FLOODING SUMMARY

At 0.0o Heel	PERM.	FLOODED WTR LTons	% FULL (Damaged)	% FULL (Intact)	SP.VOL. ft3/LT	OUTFLOW LTons
THRUSTER RM	0.85	149.8	FREE	0.0	----	----
STORAGE	0.95	207.2	FREE	0.0	----	----
Totals		357.0				

INTACT DATA

Draft at AP = 6.470 ft	KMt = 50.919 ft	LCG = 106.193A ft-FP
Draft at FP = 6.470 ft	VCG = 27.800 ft	LCB = 106.193A ft-FP
Displacement = 1837.5 LTons	Gmt = 23.119 ft	TCG = 0.000 ft-CL

DRAFT/GZ DATA

HEEL degrees	RIGHTING ARM ft	DRAFT AFT ft	DRAFT FWD ft	FLOODED WATER LTons
0.00	0.000	4.883	10.776	357.0
5.00S	1.616	4.802	10.820	360.1
10.00S	2.791	4.640	11.140	370.8
15.00S	2.667	4.306	12.318	385.2
20.00S	1.535	3.847	13.944	395.9
25.00S	-0.119	3.263	15.879	404.0
30.00S	-1.985	2.588	18.076	410.1
35.00S	-3.940	1.795	20.610	415.4
40.00S	-5.921	0.879	23.538	419.9
50.00S	-9.810	-1.467	31.079	427.0

Note: Drafts are measured at A.P. and F.P along ship's centerline

GZ SUMMARY (Evaluated per IMO (SOLAS'90) Rules for Passenger Ships)
 Available Required

Static Heel Angle	0.00 deg	7.00 deg
Freeboard to Downflooding	3.612 ft	
Angle at Maximum GZ	13.00S deg	
Maximum GZ	2.901 ft	1.340 ft
Range of Positive GZ	24.67 deg	15.00 deg
Gmt (upright damaged)	18.686 ft	
Righting Area (0.00-1.00)	42.905 ft-deg	2.820 ft-deg

DPRT003A: STOR1 OFFICE
 198' CASINO BOAT

aged Compartments:
 STORAGE OFFICES

	DISPLACEMENT LTons	DRAFT AFT ft	DRAFT FWD ft	TRIM ft	HEEL deg.	UPRIGHT GMT ft
INTACT	1,837.5	6.470	6.470	0.000	0.00	23.119
DAMAGED	2,400.9	5.021	12.000	6.978F	0.00	16.103

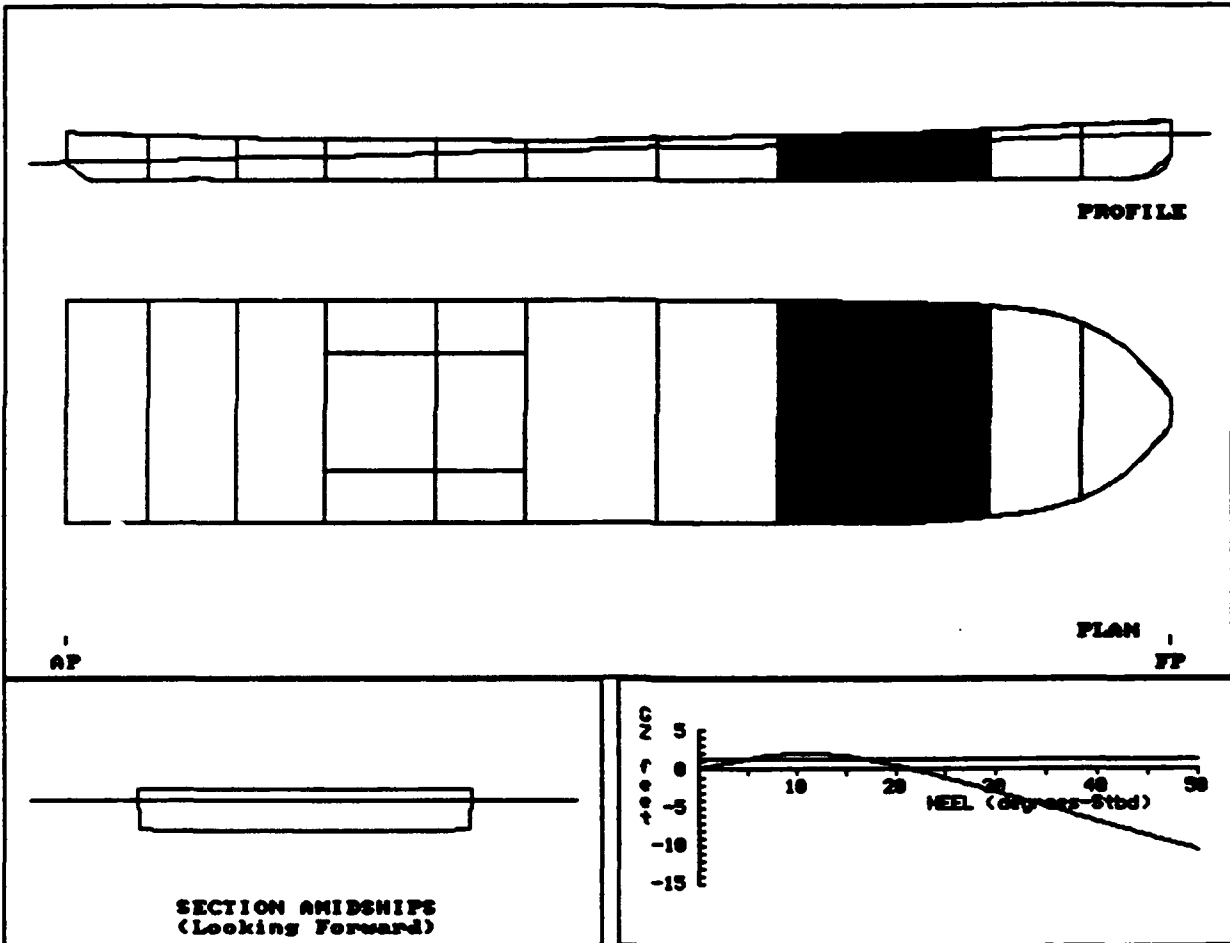

OFFICE LOUNGE
 198' CASINO BOAT

Managed Compartments:

OFFICES LOUNGE/HEAD

	DISPLACEMENT LTons	DRAFT AFT ft	DRAFT FWD ft	TRIM ft	HEEL deg.	UPRIGHT GMT ft
INTACT	1,837.5	6.470	6.470	0.000	0.00	23.119
DAMAGED	2,739.3	6.424	12.641	6.217F	0.00	12.131

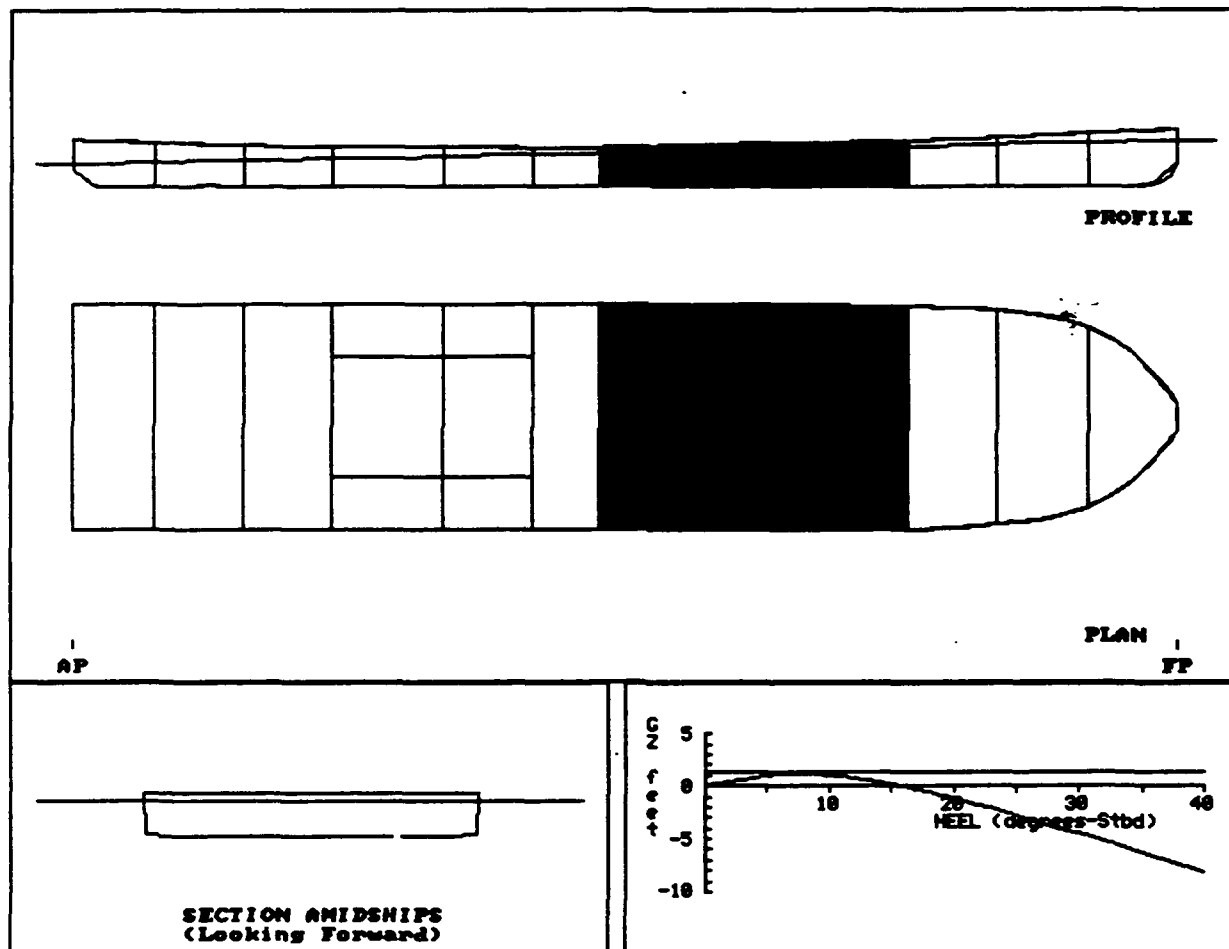

**OFFICE LOUNGE
 198' CASINO BOAT**

COMPARTMENT FLOODING SUMMARY

At 0.0o Heel	PERM.	FLOODED WTR LTons	% FULL (Damaged)	% FULL (Intact)	SP.VOL. ft3/LT	OUTFLOW LTons
OFFICES	0.95	351.9	FREE	0.0	----	----
LOUNGE/HEAD	0.95	524.2	FREE	0.0	----	----
Totals		876.1				

INTACT DATA

Draft at AP = 6.280 ft Kmt = 52.332 ft LCG = 106.130A ft-FP
 Draft at FP = 6.280 ft VCG = 28.400 ft LCB = 106.130A ft-FP
 Displacement = 1777.9 LTons Gmt = 23.932 ft TCG = 0.000 ft-CL

DRAFT/GZ DATA

HEEL degrees	RIGHTING ARM ft	DRAFT AFT ft	DRAFT FWD ft	FLOODED WATER LTons
0.00	0.000	6.223	12.307	876.1
5.00S	1.037	6.247	12.257	868.9
10.00S	1.238	6.288	12.721	842.0
15.00S	0.531	6.580	13.713	822.2
20.00S	-0.806	7.040	15.053	805.9
27.00S	-3.208	7.689	17.381	787.6
30.00S	-4.312	7.992	18.500	781.9
35.00S	-6.187	8.498	20.610	774.8
40.00S	-8.059	9.069	23.022	769.2

Note: Drafts are measured at A.P. and F.P along ship's centerline

GZ SUMMARY (Evaluated per IMO (SOLAS'90) Rules for Passenger Ships)

	Available	Required
Static Heel Angle	0.00 deg	7.00 deg
Freeboard to Downflooding	-12.286 ft	
Angle at Maximum GZ	9.00S deg	
*** Maximum GZ	1.279 ft	1.380 ft
Range of Positive GZ	17.20 deg	15.00 deg
Gmt (upright damaged)	12.415 ft	
Righting Area (0.00-3.20)	14.179 ft-deg	2.820 ft-deg

*** indicates failure to meet criterion

DPRT004A: OFFICE LOUNGE
 198' CASINO BOAT

arranged Compartments:
 OFFICES LOUNGE/HEAD

	DISPLACEMENT LTons	DRAFT AFT ft	DRAFT FWD ft	TRIM ft	HEEL deg.	UPRIGHT Gmt ft
INTACT	1,837.5	6.470	6.470	0.000	0.00	23.119
DAMAGED	2,487.9	6.035	11.419	5.384F	0.00	14.372

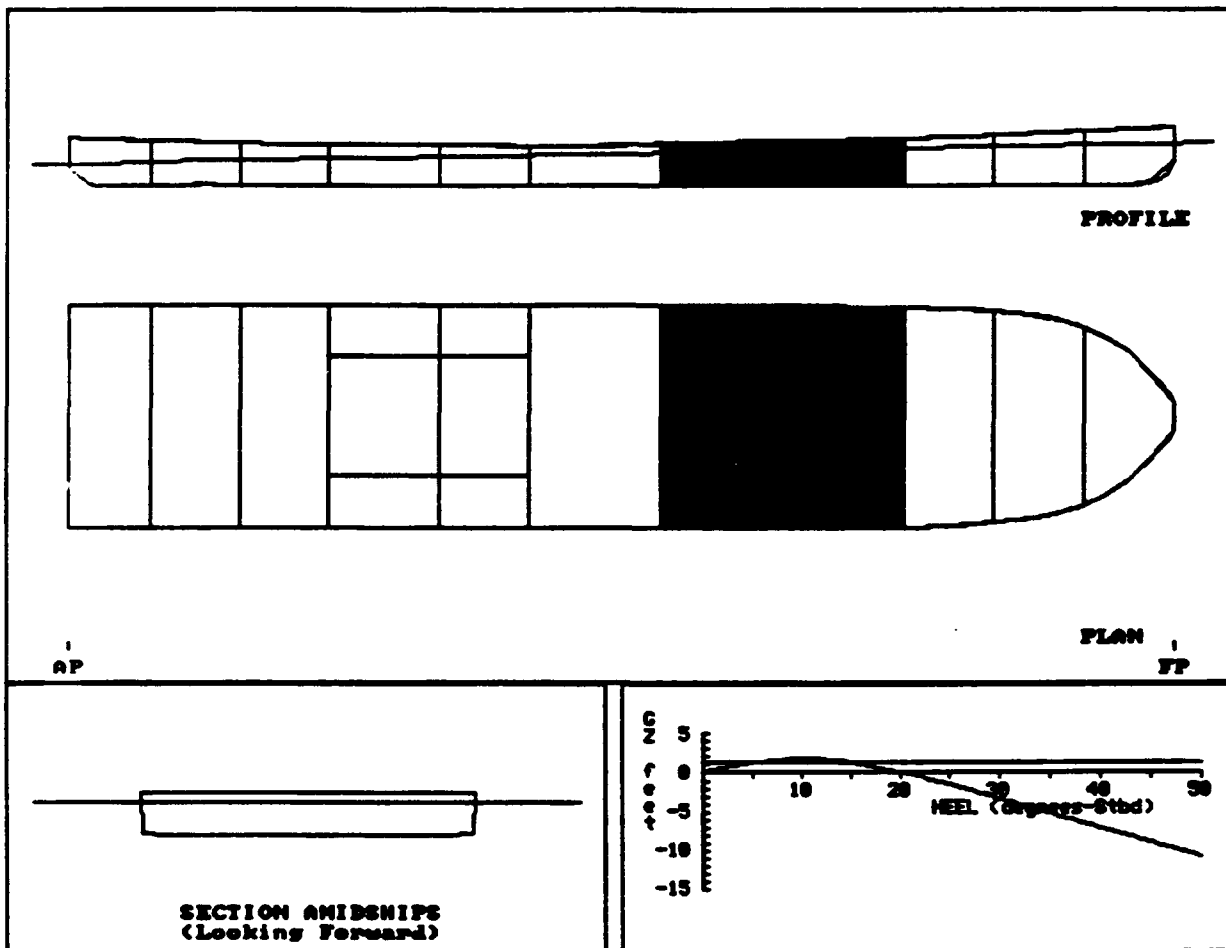

DPRT004A: OFFICE LOUNGE
 198' CASINO BOAT

COMPARTMENT FLOODING SUMMARY

At 0.0o Heel	PERM.	FLOODED WTR LTons	% FULL (Damaged)	% FULL (Intact)	SP.VOL. ft3/LT	OUTFLOW LTons
OFFICES	0.95	327.9	FREE	0.0	----	----
LOUNGE/HEAD	0.95	322.4	FREE	0.0	----	----
Totals		650.4				

INTACT DATA

Draft at AP = 6.470 ft Kmt = 50.919 ft LCG = 106.193A ft-FP
 Draft at FP = 6.470 ft VCG = 27.800 ft LCB = 106.193A ft-FP
 Displacement = 1837.5 LTons Gmt = 23.119 ft TCG = 0.000 ft-CL

DRAFT/GZ DATA

HEEL degrees	RIGHTING ARM ft	DRAFT AFT ft	DRAFT FWD ft	FLOODED WATER LTons
0.00	0.000	6.035	11.419	650.4
5.00	1.234	6.042	11.372	648.9
10.00	1.807	6.091	11.610	632.9
15.00	1.353	6.338	12.404	618.8
20.00	0.139	6.729	13.513	606.2
25.00	-1.484	7.131	14.818	596.6
30.00	-3.283	7.547	16.297	589.5
35.00	-5.148	7.990	17.982	584.2
40.00	-7.024	8.481	19.919	580.1
50.00	-10.679	9.701	24.934	574.5

Note: Drafts are measured at A.P. and F.P along ship's centerline

GZ SUMMARY (Evaluated per IMO (SOLAS '90) Rules for Passenger Ships)

	Available	Required
Stic Heel Angle	0.00 deg	7.00 deg
Board to Downflooding	2.823 ft	
le at Maximum GZ	11.00S deg	
imum GZ	1.807 ft	1.340 ft
ge of Positive GZ	20.46 deg	15.00 deg
(upright damaged)	14.372 ft	
ting Area (0.00-1.46)	23.448 ft-deg	2.820 ft-deg

DPRT005A: LONGE STOR2
 198' CASINO BOAT

Damaged Compartments:
 LOUNGE/HEAD STORES2

	DISPLACEMENT LTons	DRAFT AFT ft	DRAFT FWD ft	TRIM ft	HEEL deg.	UPRIGHT GMT ft
INTACT	1,837.5	6.470	6.470	0.000	0.00	23.119
DAMAGED	2,474.2	7.531	9.602	2.072F	0.00	12.926

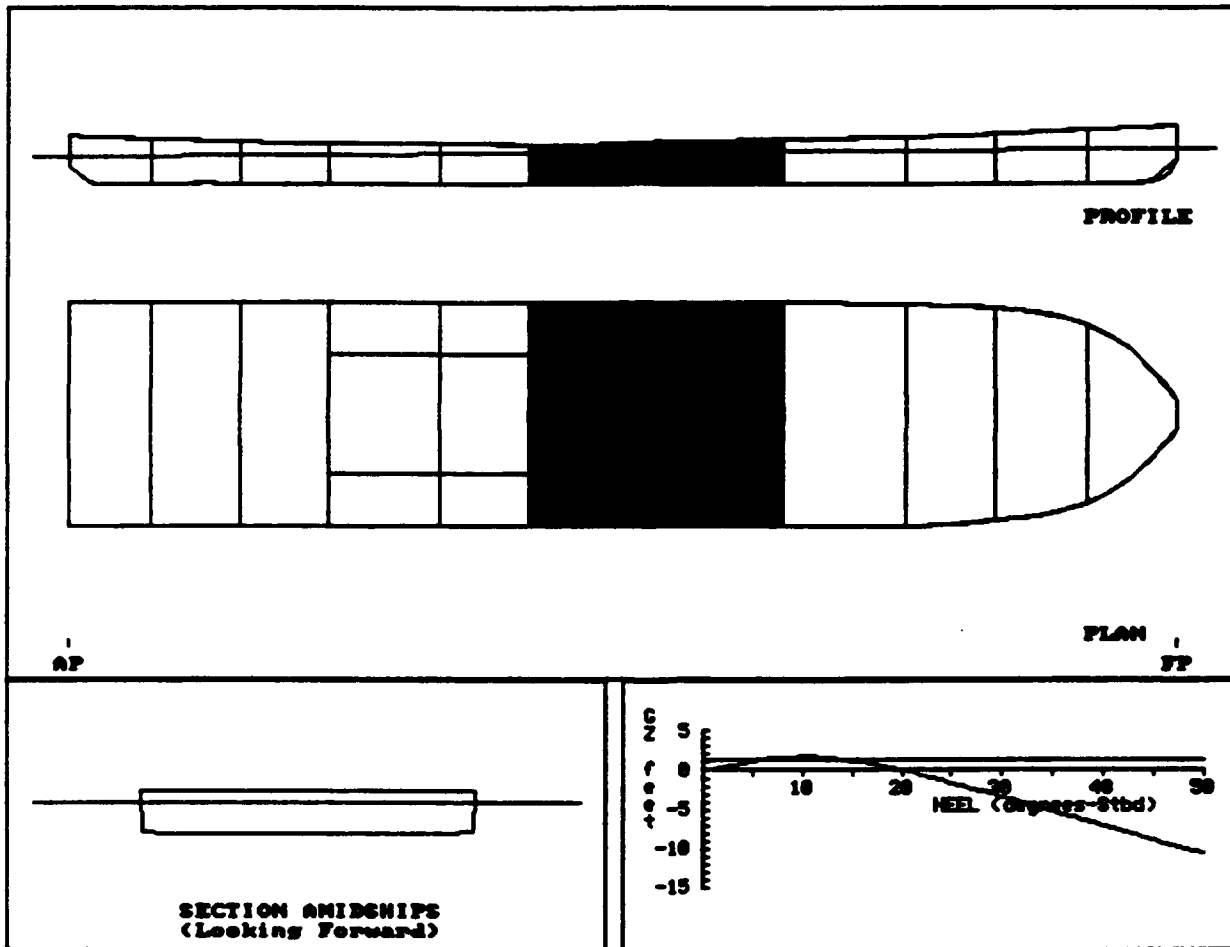

DPR006A: STOR2 BLKH20(S)
 198' CASINO BOAT

Imaged Compartments:
 STORES2 BLACK WATER

	DISPLACEMENT LTons	DRAFT AFT ft	DRAFT FWD ft	TRIM ft	HEEL deg.	UPRIGHT GMT ft
INTACT	1,837.5	6.470	6.470	0.000	0.00	23.119
DAMAGED	2,173.4	7.497	7.580	0.083F	1.80S	15.553

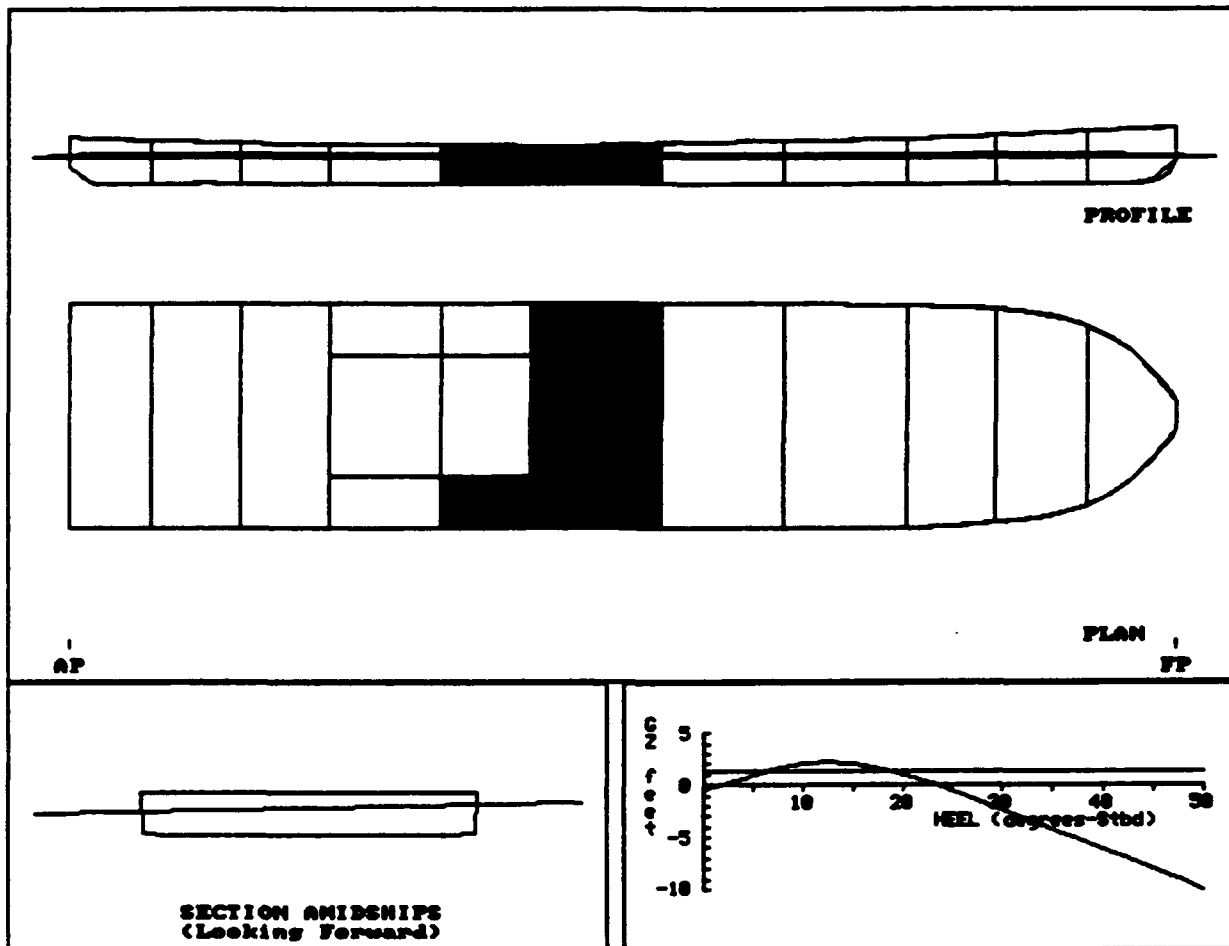

DPRT006A: STOR2 BLK20(S)
 198' CASINO BOAT

COMPARTMENT FLOODING SUMMARY

At 1.8oS Heel	PERM.	FLOODED WTR LTons	% FULL (Damaged)	% FULL (Intact)	SP.VOL. ft3/LT	OUTFLOW LTons
STORES2	0.95	292.5	FREE	0.0	----	----
BLACK WATER	0.95	50.0	FREE	10.0	35.0063	6.6
Totals		342.5				6.6

INTACT DATA

Draft at AP = 6.470 ft KMT = 50.919 ft LCG = 106.193A ft-FP
 Draft at FP = 6.470 ft VCG = 27.800 ft LCB = 106.193A ft-FP
 Displacement = 1837.5 LTons GMT = 23.119 ft TCG = 0.000 ft-CL

DRAFT/GZ DATA

HEEL degrees	RIGHTING ARM ft	DRAFT AFT ft	DRAFT FWD ft	FLOODED WATER LTons
0.00	-0.489	7.468	7.585	337.6
5.00S	0.883	7.546	7.565	351.3
10.00S	2.065	7.715	7.486	353.0
15.00S	2.068	8.438	7.385	342.1
20.00S	1.038	9.436	7.330	334.3
25.00S	-0.527	10.488	7.319	329.8
30.00S	-2.319	11.641	7.317	326.8
35.00S	-4.210	12.933	7.312	324.7
40.00S	-6.132	14.407	7.307	323.1
50.00S	-9.930	18.179	7.280	320.7

Note: Drafts are measured at A.P. and F.P along ship's centerline

GZ SUMMARY (Evaluated per IMO (SOLAS'90) Rules for Passenger Ships)

	Available	Required
Static Heel Angle	1.80S deg	7.00 deg
Freeboard to Downflooding	3.148 ft	
Angle at Maximum GZ	13.00S deg	
Maximum GZ	2.223 ft	1.340 ft
Range of Positive GZ	21.62 deg	15.00 deg
Righting Area (1.80-7.00)	29.485 ft-deg	2.820 ft-deg

DPRT007A: STOR2 BLK20(P)
 198' CASINO BOAT

Imaged Compartments:
 STOR22 BLACK #20(P)

	DISPLACEMENT LTons	DRAFT AFT ft	DRAFT FWD ft	TRIM ft	HEEL deg.	UPRIGHT GMT ft
INTACT	1,837.5	6.470	6.470	0.000	0.00	23.119
DAMAGED	2,173.4	7.497	7.580	0.083F	1.80P	15.553

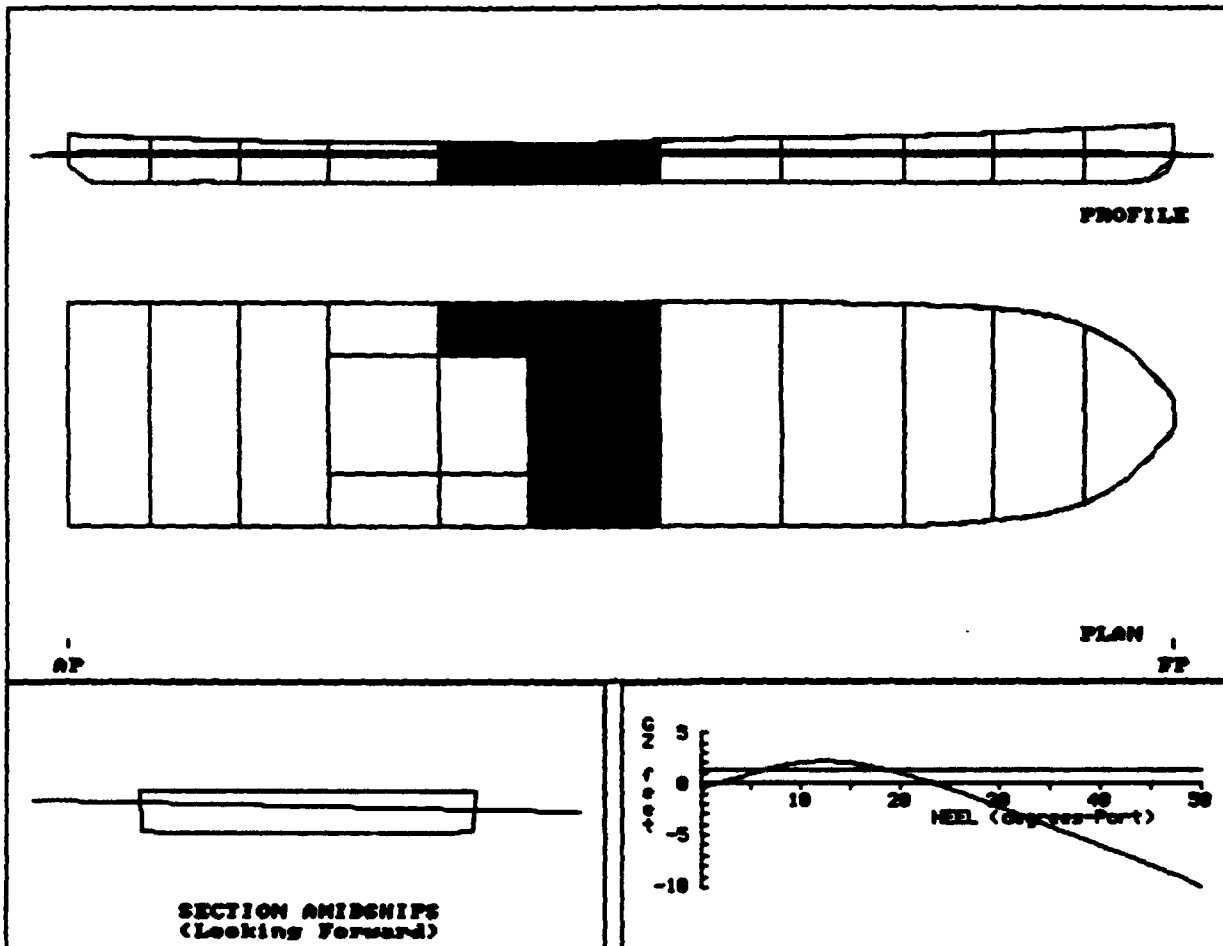

DPRT007A: STOR2 BLK20(P)
 198' CASINO BOAT

COMPARTMENT FLOODING SUMMARY

At 1.80P Heel	PERM.	FLOODED WTR LTons	% FULL (Damaged)	% FULL (Intact)	SP.VOL. ft ³ /LT	OUTFLOW LTons
STORES2	0.95	292.5	FREE	0.0	----	----
BLACK H2O(P)	0.95	50.0	FREE	10.0	35.0063	6.6
Totals		342.5				6.6

INTACT DATA

Draft at AP = 6.470 ft Kmt = 50.919 ft LCG = 106.193A ft-FP
 Draft at FP = 6.470 ft VCG = 27.800 ft LCB = 106.193A ft-FP
 Displacement = 1837.5 LTons GMT = 23.119 ft TCG = 0.000 ft-CL

DRAFT/GZ DATA

HEEL degrees	RIGHTING ARM ft	DRAFT AFT ft	DRAFT FWD ft	FLOODED WATER LTons
0.00	-0.489	7.468	7.585	337.6
5.00P	0.883	7.546	7.565	351.3
10.00P	2.065	7.715	7.486	353.0
15.00P	2.067	8.438	7.385	342.1
20.00P	1.037	9.437	7.330	334.4
25.00P	-0.528	10.489	7.319	329.8
30.00P	-2.320	11.641	7.317	326.8
35.00P	-4.210	12.933	7.312	324.7
40.00P	-6.132	14.408	7.307	323.1
50.00P	-9.930	18.180	7.280	320.7

Note: Drafts are measured at A.P. and F.P along ship's centerline

GZ SUMMARY (Evaluated per IMO (SOLAS'90) Rules for Passenger Ships)

	Available	Required
Static Heel Angle	1.80P deg	7.00 deg
Freeboard to Downflooding	5.033 ft	
Angle at Maximum GZ	13.00P deg	
Maximum GZ	2.223 ft	1.340 ft
Range of Positive GZ	21.62 deg	15.00 deg
Righting Area (1.80-1.00)	29.481 ft-deg	2.820 ft-deg

DPRT008A: BLK H₂O/FUEL (S)
 198' CASINO BOAT

Damaged Compartments:

BLACK WATER FUEL

	DISPLACEMENT LTons	DRAFT AFT ft	DRAFT FWD ft	TRIM ft	HEEL deg.	UPRIGHT GMT ft
INTACT	1,837.5	6.470	6.470	0.000	0.00	23.119
DAMAGED	1,843.9	6.449	6.540	0.091F	0.20S	19.357

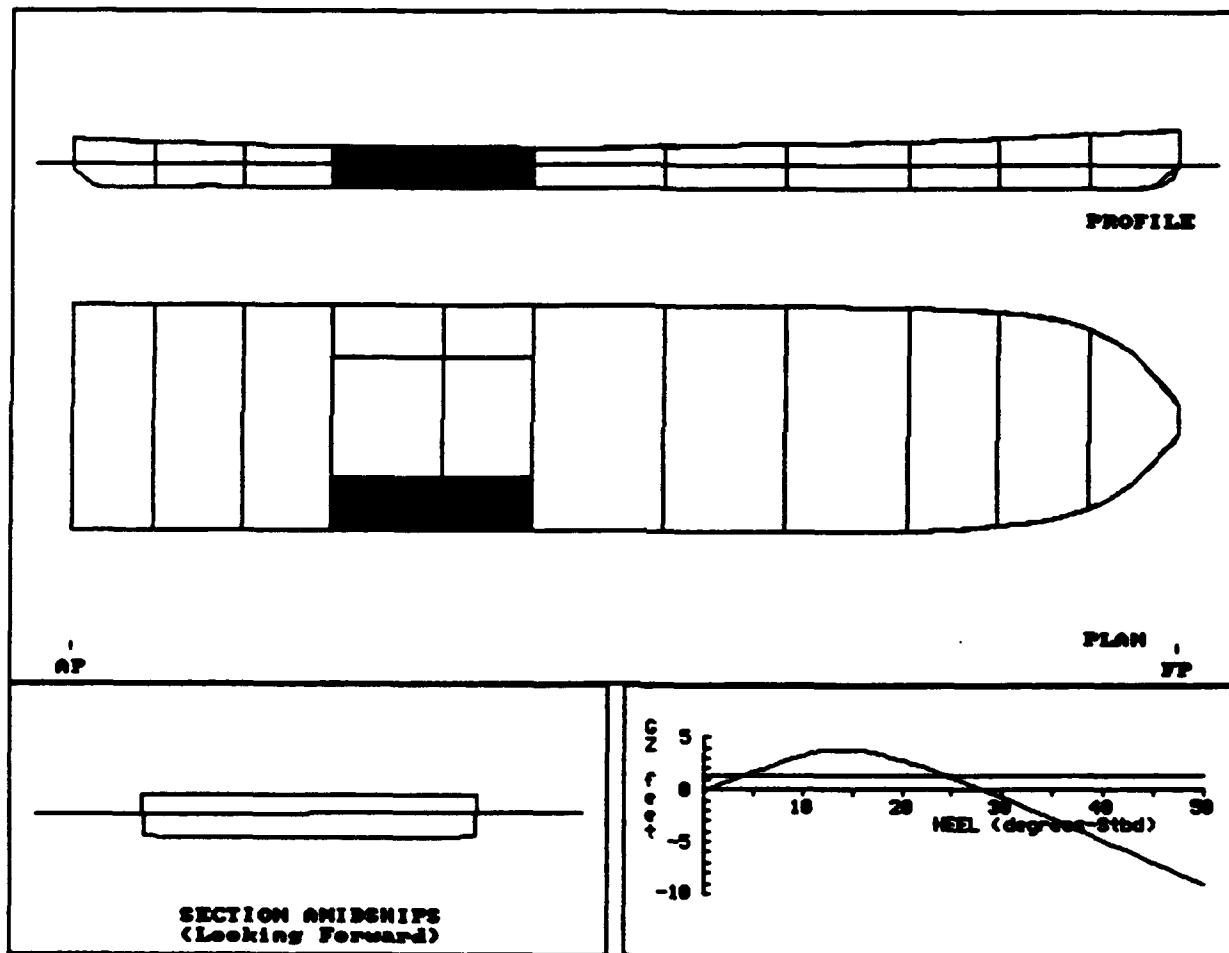

DPRT008A: BLKH20/FUEL (8)
 198' CASINO BOAT

COMPARTMENT FLOODING SUMMARY

At 0.2oS Heel	PERM.	FLOODED WTR LTons	% FULL (Damaged)	% FULL (Intact)	SP.VOL. ft3/LT	OUTFLOW LTons
BLACK WATER	0.95	39.8	FREE	10.0	35.0063	6.6
FUEL	0.95	49.7	FREE	100.0	38.5800	76.5
Totals		89.4				83.1

INTACT DATA

Draft at AP = 6.470 ft	KMt = 50.919 ft	LCG = 106.193A ft-FP
Draft at FP = 6.470 ft	VCG = 27.800 ft	LCB = 106.193A ft-FP
Displacement = 1837.5 LTons	Gmt = 23.119 ft	TCG = 0.000 ft-CL

DRAFT/GZ DATA

HEEL degrees	RIGHTING ARM ft	DRAFT AFT ft	DRAFT FWD ft	FLOODED WATER LTons
0.00	-0.068	6.442	6.541	88.2
5.00S	1.629	6.606	6.522	117.2
10.00S	3.274	6.763	6.446	143.8
15.00S	3.801	7.211	6.245	150.3
20.00S	2.819	7.714	6.035	150.3
25.00S	1.181	8.276	5.806	150.3
30.00S	-0.741	8.908	5.544	150.3
35.00S	-2.798	9.616	5.249	150.3
40.00S	-4.911	10.423	4.913	150.3
50.00S	-9.130	12.495	4.041	150.3

Note: Drafts are measured at A.P. and F.P along ship's centerline

GZ SUMMARY (Evaluated per IMO (SOLAS'90) Rules for Passenger Ships)
 Available Required

Static Heel Angle	0.20S deg	7.00 deg
Freeboard to Downflooding	5.032 ft	
Angle at Maximum GZ	15.00S deg	
Maximum GZ	3.825 ft	1.340 ft
Range of Positive GZ	27.93 deg	15.00 deg
Righting Area (0.20-8.00)	56.692 ft-deg	2.820 ft-deg

VMTSC -- 198' CASINO BOAT
 Project No. DAMSTAB (by: DYER)

HEC-DAMSTB V1.22
 09-15-1993

DPRT009A: BLK20/FUEL(P)
 198' CASINO BOAT

Imaged Compartments:
 BLACK H2O(P) FUEL (P)

	DISPLACEMENT LTons	DRAFT AFT ft	DRAFT FWD ft	TRIM ft	HEEL deg.	UPRIGHT GMT ft
INTACT	1,837.5	6.470	6.470	0.000	0.00	23.119
DAMAGED	1,843.8	6.448	6.540	0.092F	0.20P	19.357

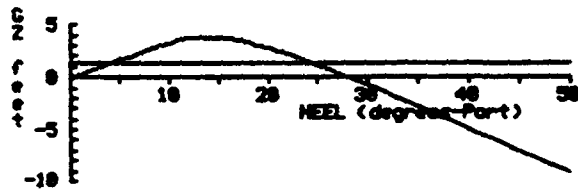
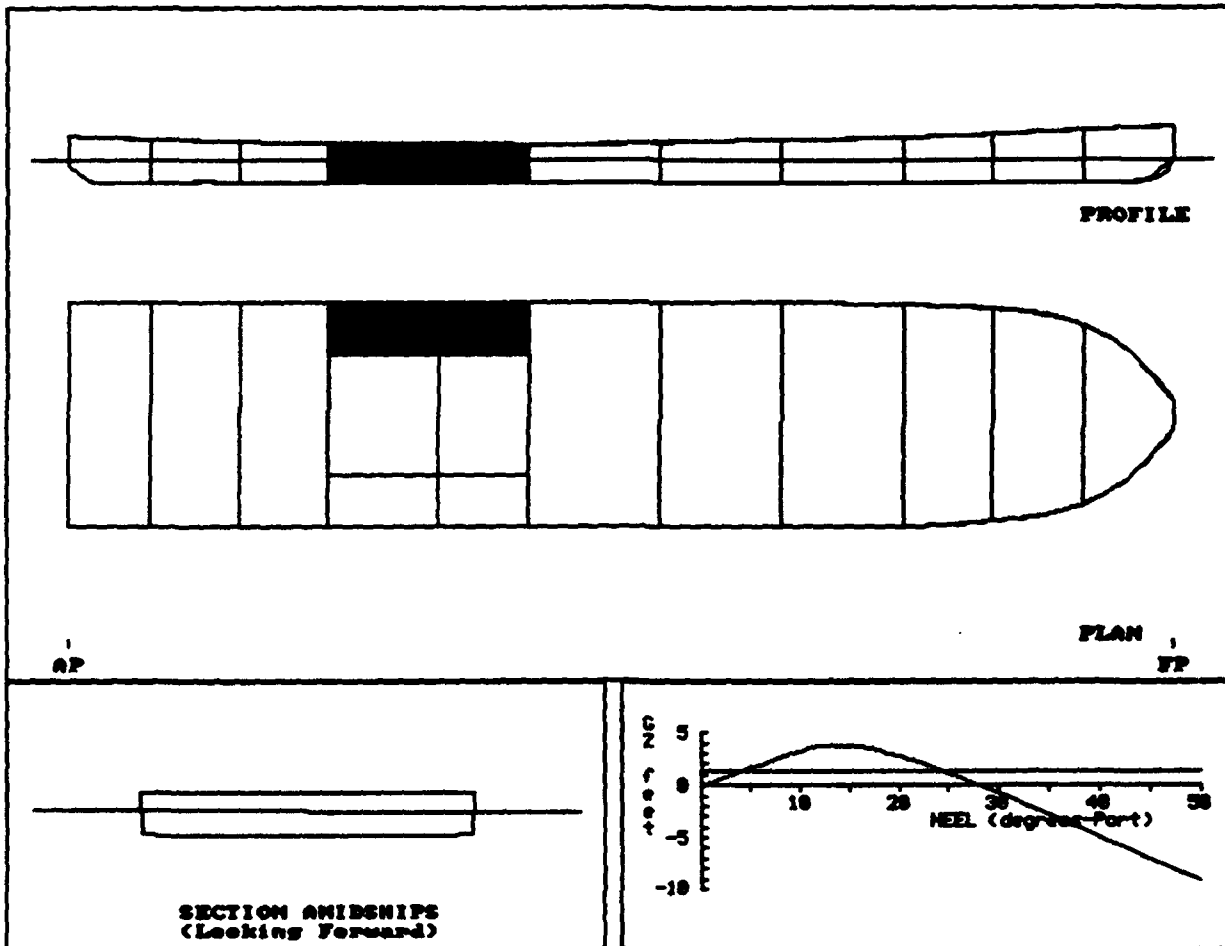

DPRT009A: BLK H2O/FUEL(P)
 198' CASINO BOAT

COMPARTMENT FLOODING SUMMARY

At 0.20P Heel	PERM.	FLOODED WTR LTons	% FULL (Damaged)	% FULL (Intact)	SP.VOL. ft ³ /LT	OUTFLOW LTons
BLACK H2O(P)	0.95	39.7	FREE	10.0	35.0063	6.6
FUEL (P)	0.95	49.6	FREE	100.0	38.5800	76.5
Totals		89.4				83.1

INTACT DATA

Draft at AP = 6.470 ft	KMt = 50.919 ft	LCG = 106.193A ft-FP
Draft at FP = 6.470 ft	VCG = 27.800 ft	LCB = 106.193A ft-FP
Displacement = 1837.5 LTons	GMT = 23.119 ft	TCG = 0.000 ft-CL

DRAFT/GZ DATA

HEEL degrees	RIGHTING ARM ft	DRAFT AFT ft	DRAFT FWD ft	FLOODED WATER LTons
0.00	-0.067	6.441	6.541	88.2
5.00P	1.630	6.606	6.522	117.2
10.00P	3.274	6.763	6.446	143.8
15.00P	3.801	7.211	6.245	150.4
20.00P	2.818	7.714	6.035	150.4
25.00P	1.181	8.277	5.806	150.4
30.00P	-0.742	8.908	5.544	150.4
35.00P	-2.799	9.617	5.249	150.4
40.00P	-4.912	10.424	4.913	150.4
50.00P	-9.130	12.496	4.041	150.4

Note: Drafts are measured at A.P. and F.P along ship's centerline

GZ SUMMARY (Evaluated per IMO (SOLAS'90) Rules for Passenger Ships)
 Available Required

Static Heel Angle	0.20P deg	7.00 deg
Freeboard to Downflooding	5.244 ft	
Angle at Maximum GZ	15.00P deg	
Maximum GZ	3.824 ft	1.340 ft
Range of Positive GZ	27.93 deg	15.00 deg
Righting Area (0.20-1.00)	56.696 ft-deg	2.820 ft-deg

DPRT010A: FUEL(S)/ENG RM
 198' CASINO BOAT

Damaged Compartments:

FUEL ENG RM

	DISPLACEMENT LTons	DRAFT AFT ft	DRAFT FWD ft	TRIM ft	HEEL deg.	UPRIGHT Gmt ft
INTACT	1,837.5	6.470	6.470	0.000	0.00	23.119
DAMAGED	1,985.4	7.796	5.917	1.879A	0.92P	17.497

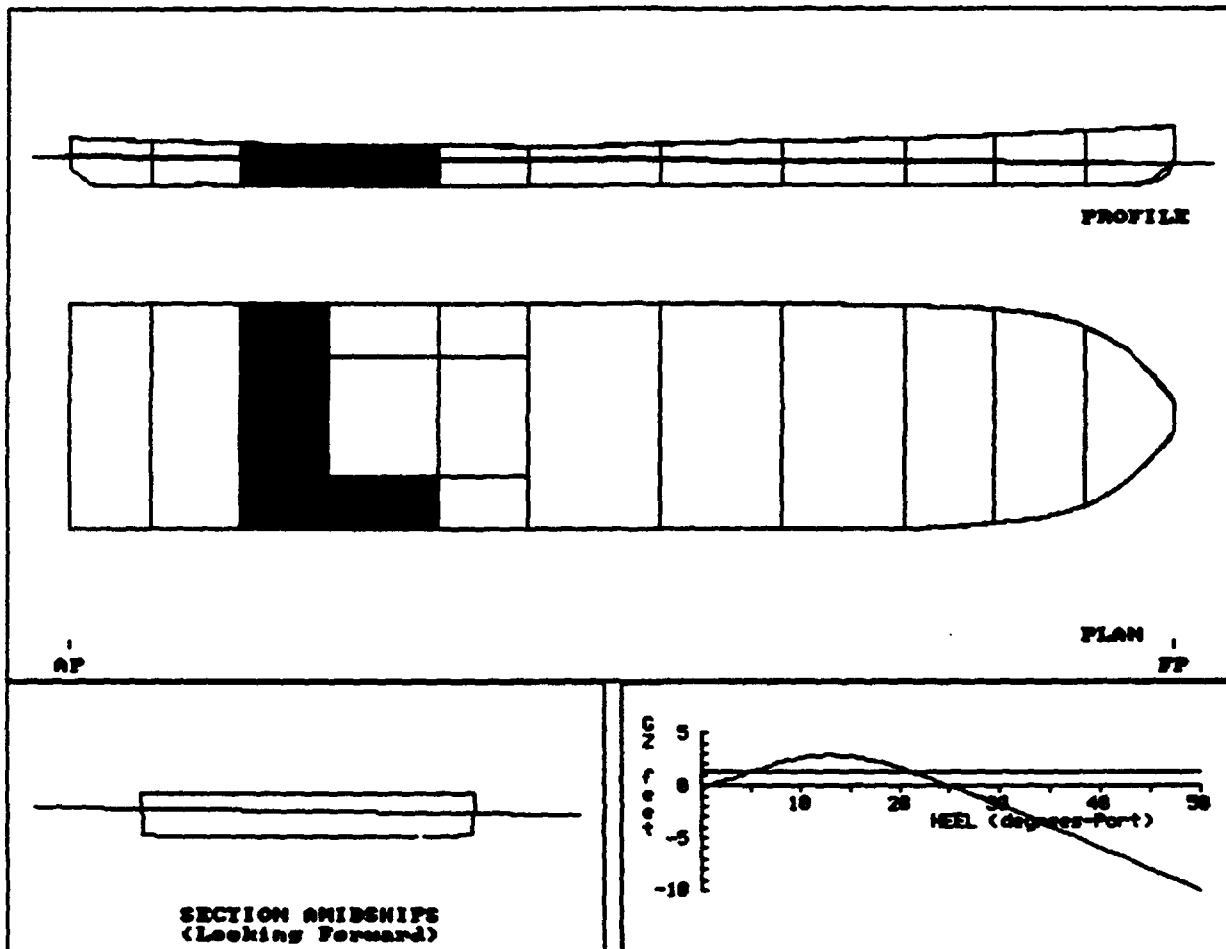

DPRT010A: FUEL(S)/ENG RM
 198' CASINO BOAT

COMPARTMENT FLOODING SUMMARY

At 0.90P Heel	PERM.	FLOODED WTR LTons	% FULL (Damaged)	% FULL (Intact)	SP.VOL. ft ³ /LT	OUTFLOW LTons
FUEL	0.95	52.2	FREE	100.0	38.5800	76.5
ENG RM	0.85	172.1	FREE	0.0	----	----
Totals		224.4				76.5

INTACT DATA

Draft at AP = 6.470 ft	KMT = 50.919 ft	LCG = 106.193A ft-FP
Draft at FP = 6.470 ft	VCG = 27.800 ft	LCB = 106.193A ft-FP
Displacement = 1837.5 LTons	GMT = 23.119 ft	TCG = 0.000 ft-CL

DRAFT/GZ DATA

HEEL degrees	RIGHTING ARM ft	DRAFT AFT ft	DRAFT FWD ft	FLOODED WATER LTons
0.00	-0.279	7.810	5.925	227.6
5.00P	1.260	7.725	5.881	209.9
10.00P	2.659	7.675	5.793	190.3
15.00P	2.808	8.116	5.544	171.6
20.00P	1.715	8.772	5.195	161.6
25.00P	0.065	9.532	4.795	157.7
30.00P	-1.827	10.429	4.333	156.8
35.00P	-3.829	11.455	3.795	156.5
40.00P	-5.874	12.624	3.184	156.3
50.00P	-9.927	15.626	1.597	156.0

Note: Drafts are measured at A.P. and F.P along ship's centerline

GZ SUMMARY (Evaluated per IMO (SOLAS'90) Rules for Passenger Ships)
 Available Required

Static Heel Angle	0.92P deg	7.00 deg
Freeboard to Downflooding	4.574 ft	
Angle at Maximum GZ	14.00P deg	
Maximum GZ	2.924 ft	1.340 ft
Range of Positive GZ	24.26 deg	15.00 deg
Righting Area (0.92-7.00)	41.371 ft-deg	2.820 ft-deg

DPR011A: FUEL(P)/ENG RM
 198' CASINO BOAT

Imaged Compartments:

FUEL (P) ENG RM

	DISPLACEMENT LTons	DRAFT AFT ft	DRAFT FWD ft	TRIM ft	HEEL deg.	UPRIGHT Gmt ft
INTACT	1,837.5	6.470	6.470	0.000	0.00	23.119
DAMAGED	1,985.4	7.795	5.917	1.878A	0.92S	17.497

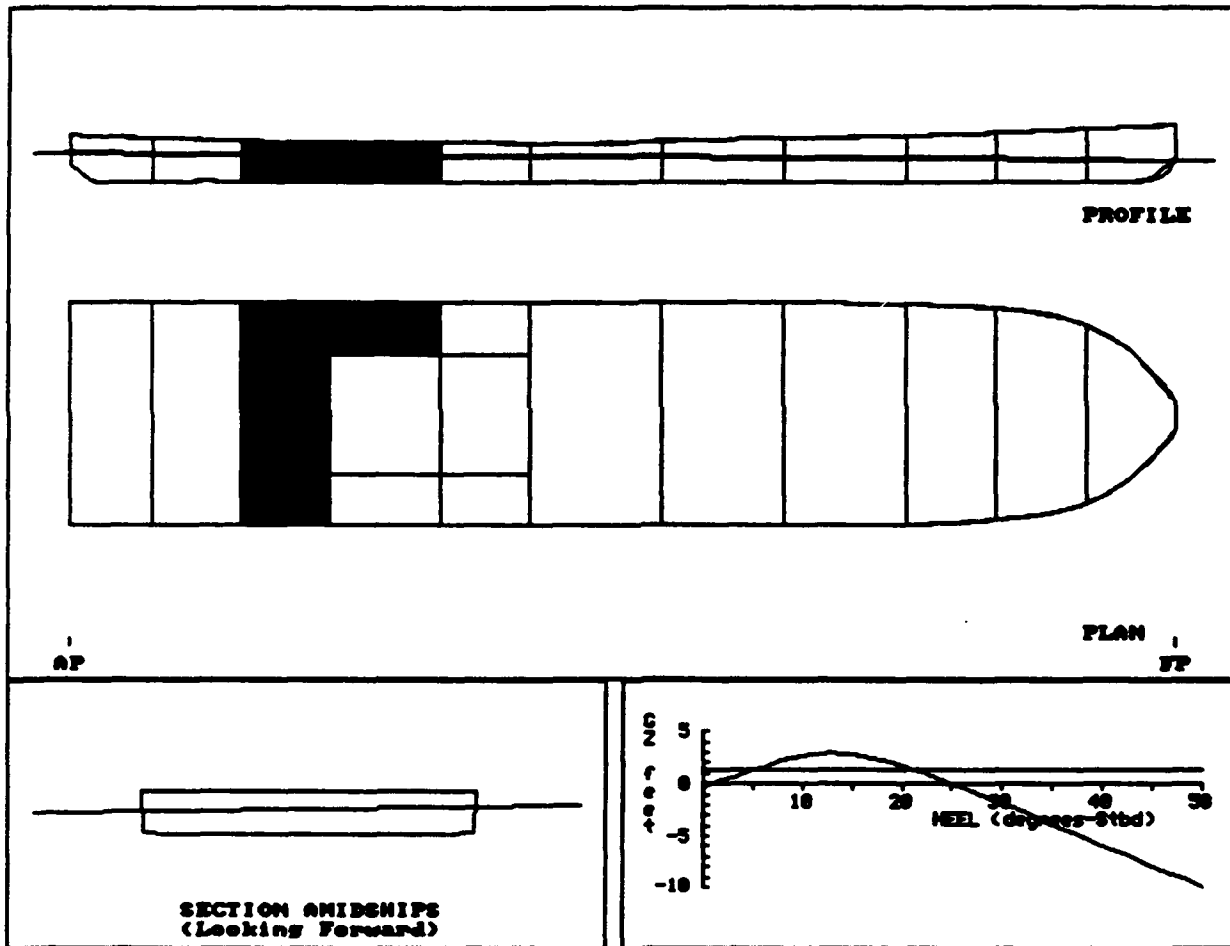

DPRT012A: ENG RM/MUFFLER
 198' CASINO BOAT

Managed Compartments:
 ENG RM MUFFLER CMT

	DISPLACEMENT LTons	DRAFT AFT ft	DRAFT FWD ft	TRIM ft	HEEL deg.	UPRIGHT GMT ft
INTACT	1,837.5	6.470	6.470	0.000	0.00	23.119
DAMAGED	2,265.6	10.524	4.608	5.916A	0.00	15.419

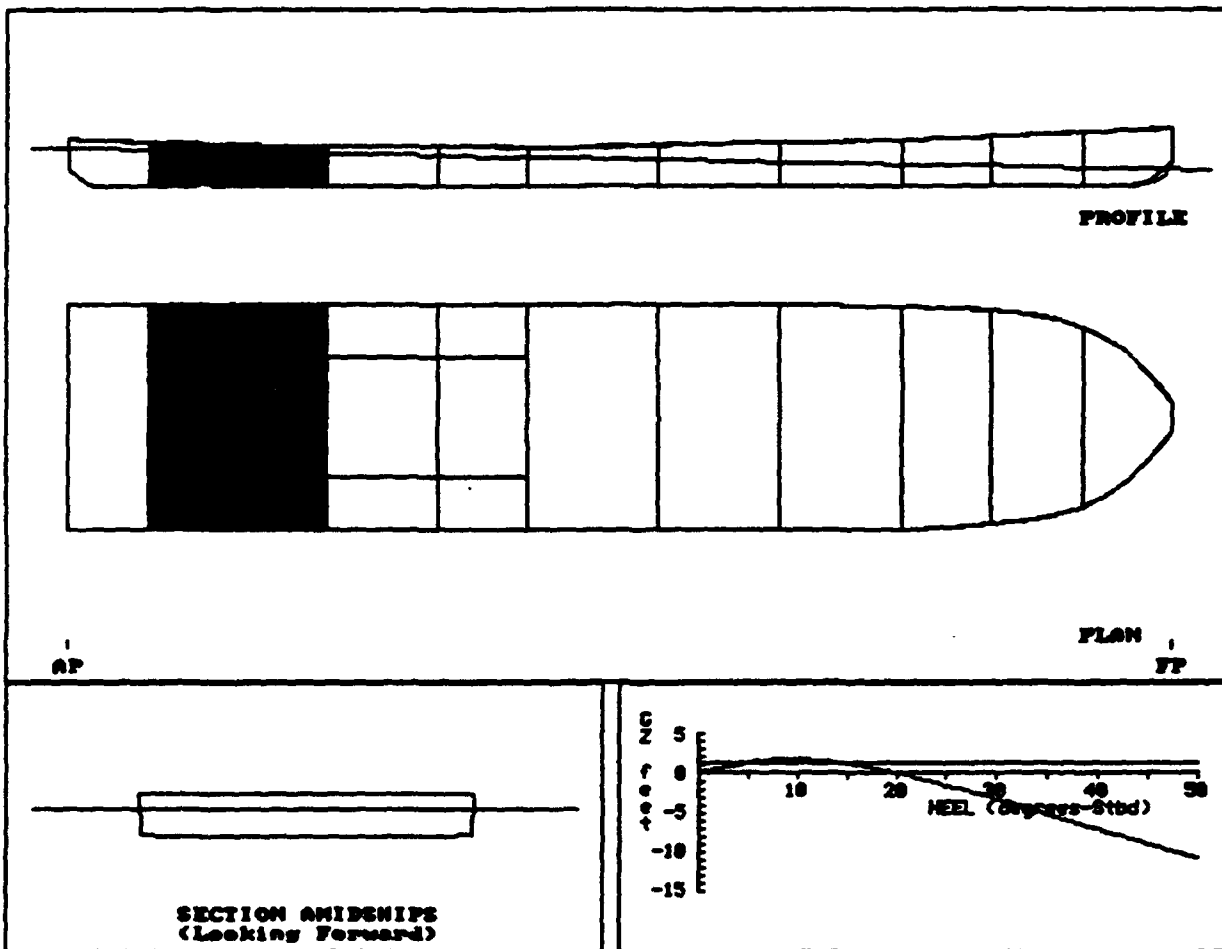

DPRT012A: ENG RM/MUFFLER
 198' CASINO BOAT

COMPARTMENT FLOODING SUMMARY

At 0.0o Heel	PERM.	FLOODED WTR LTons	% FULL (Damaged)	% FULL (Intact)	SP.VOL. ft3/LT	OUTFLOW LTons
ENG RM	0.85	217.6	FREE	0.0	----	----
MUFFLER CMPT	0.85	210.5	FREE	0.0	----	----
Totals		428.1				

INTACT DATA

Draft at AP = 6.470 ft	Kmt = 50.919 ft	LCG = 106.193A ft-FP
Draft at FP = 6.470 ft	VCG = 27.800 ft	LCB = 106.193A ft-FP
Displacement = 1837.5 LTons	Gmt = 23.119 ft	TCG = 0.000 ft-CL

DRAFT/GZ DATA

HEEL degrees	RIGHTING ARM ft	DRAFT AFT ft	DRAFT FWD ft	FLOODED WATER LTons
0.00	0.000	10.524	4.608	428.1
5.00S	1.323	10.574	4.552	427.1
10.00S	1.808	11.437	4.137	424.5
15.00S	1.285	13.263	3.358	429.1
20.00S	0.086	15.661	2.398	434.8
25.00S	-1.525	18.470	1.247	439.7
30.00S	-3.338	21.665	-0.123	443.3
35.00S	-5.237	25.300	-1.723	446.2
40.00S	-7.149	29.458	-3.574	448.7
50.00S	-10.860	40.057	-8.362	452.2

Note: Drafts are measured at A.P. and F.P along ship's centerline

GZ SUMMARY (Evaluated per IMO (SOLAS'90) Rules for Passenger Ships)

	Available	Required
Static Heel Angle	0.00 deg	7.00 deg
Freeboard to Downflooding	1.986 ft	
Angle at Maximum GZ	11.00S deg	
Maximum GZ	1.808 ft	1.340 ft
Range of Positive GZ	20.29 deg	15.00 deg
Gmt (upright damaged)	15.419 ft	
Righting Area (0.00-1.29)	23.434 ft-deg	2.820 ft-deg

**DPRT013A: MUFFLER/STEER
 198' CASINO BOAT**

Imaged Compartments:
 MUFFLER CMT STEERING RM

	DISPLACEMENT LTons	DRAFT AFT ft	DRAFT FWD ft	TRIM ft	HEEL deg.	UPRIGHT GMT ft
INTACT	1,837.5	6.470	6.470	0.000	0.00	23.119
DAMAGED	2,171.6	10.124	4.425	5.699A	0.00	15.265

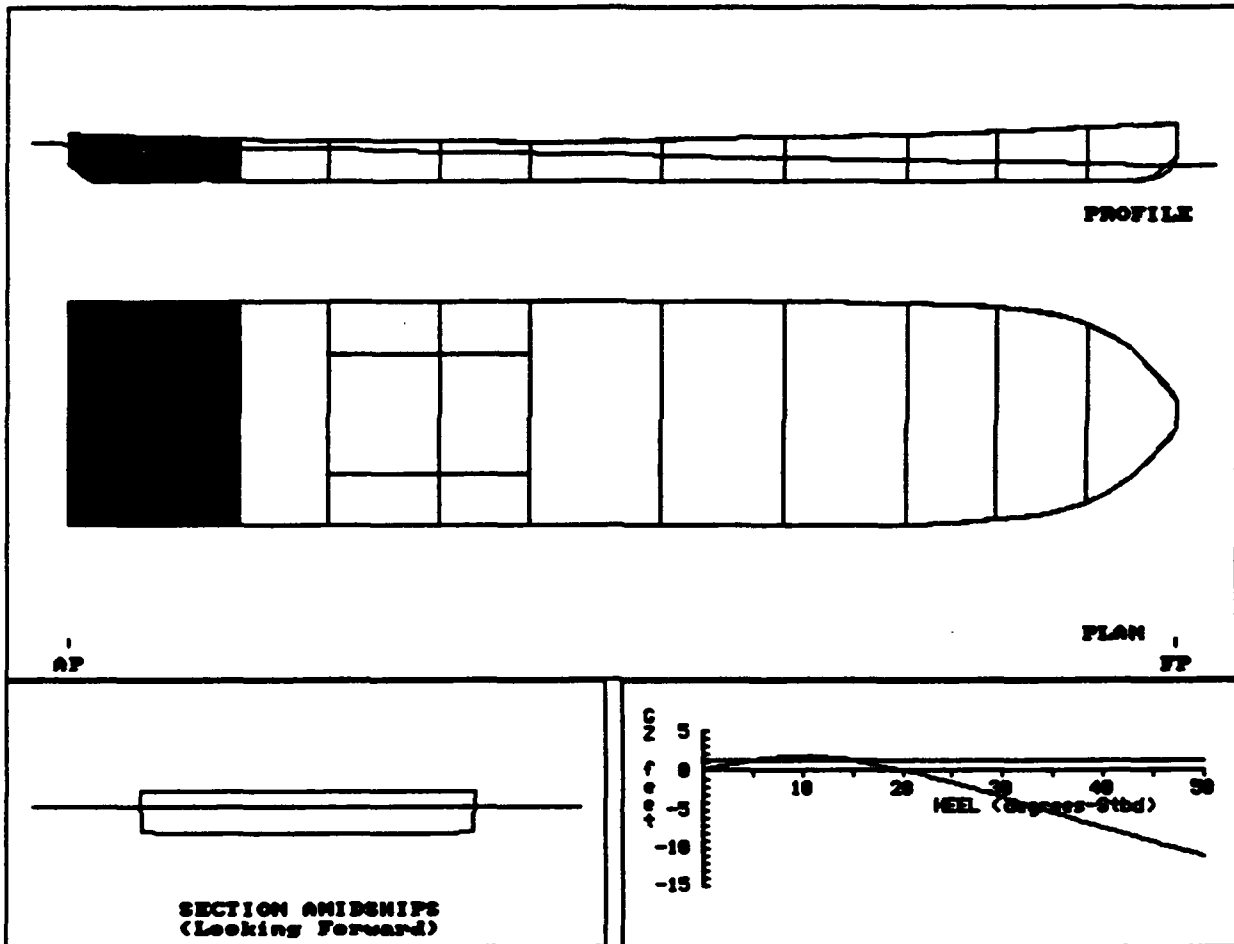

**DPRT013A: MUFFLER/STEER
 198' CASINO BOAT**

COMPARTMENT FLOODING SUMMARY

At 0.0o Heel	PERM.	FLOODED WTR LTons	% FULL (Damaged)	% FULL (Intact)	SP.VOL. ft3/LT	OUTFLOW LTons
MUFFLER CMPT	0.85	201.8	FREE	0.0	----	----
STEERING RM	0.85	132.3	FREE	0.0	----	----
Totals		334.0				

INTACT DATA

Draft at AP = 6.470 ft	Kmt = 50.919 ft	LCG = 106.193A ft-FP
Draft at FP = 6.470 ft	VCG = 27.800 ft	LCB = 106.193A ft-FP
Displacement = 1837.5 LTons	Gmt = 23.119 ft	TCG = 0.000 ft-CL

DRAFT/GZ DATA

HEEL degrees	RIGHTING ARM ft	DRAFT AFT ft	DRAFT FWD ft	FLOODED WATER LTons
0.00	0.000	10.124	4.425	334.0
5.00S	1.319	10.174	4.366	335.8
10.00S	1.901	11.012	3.914	343.7
15.00S	1.405	12.919	3.001	358.0
20.00S	0.180	15.459	1.844	371.8
25.00S	-1.481	18.462	0.423	383.4
30.00S	-3.348	21.927	-1.286	393.3
35.00S	-5.294	25.910	-3.305	401.7
40.00S	-7.260	30.541	-5.711	409.1
50.00S	-11.040	42.155	-11.709	419.2

Note: Drafts are measured at A.P. and F.P. along ship's centerline

GZ SUMMARY (Evaluated per IMO (SOLAS'90) Rules for Passenger Ships)

	Available	Required
Static Heel Angle	0.00 deg	7.00 deg
Freeboard to Downflooding	2.353 ft	
Angle at Maximum GZ	11.00S deg	
Maximum GZ	1.901 ft	1.340 ft
Range of Positive GZ	20.59 deg	15.00 deg
Gmt (upright damaged)	15.265 ft	
Righting Area (0.00-4.59)	24.771 ft-deg	2.820 ft-deg

DPRT014A: OFFICE/LOUNGE 2
 198' CASINO BOAT

Imaged Compartments:
 OFFICES LOUNGE/HEAD

	DISPLACEMENT LTons	DRAFT AFT ft	DRAFT FWD ft	TRIM ft	HEEL deg.	UPRIGHT GMT ft
INTACT	1,837.5	6.470	6.470	0.000	0.00	23.119
DAMAGED	2,487.9	6.035	11.419	5.384F	0.00	14.372

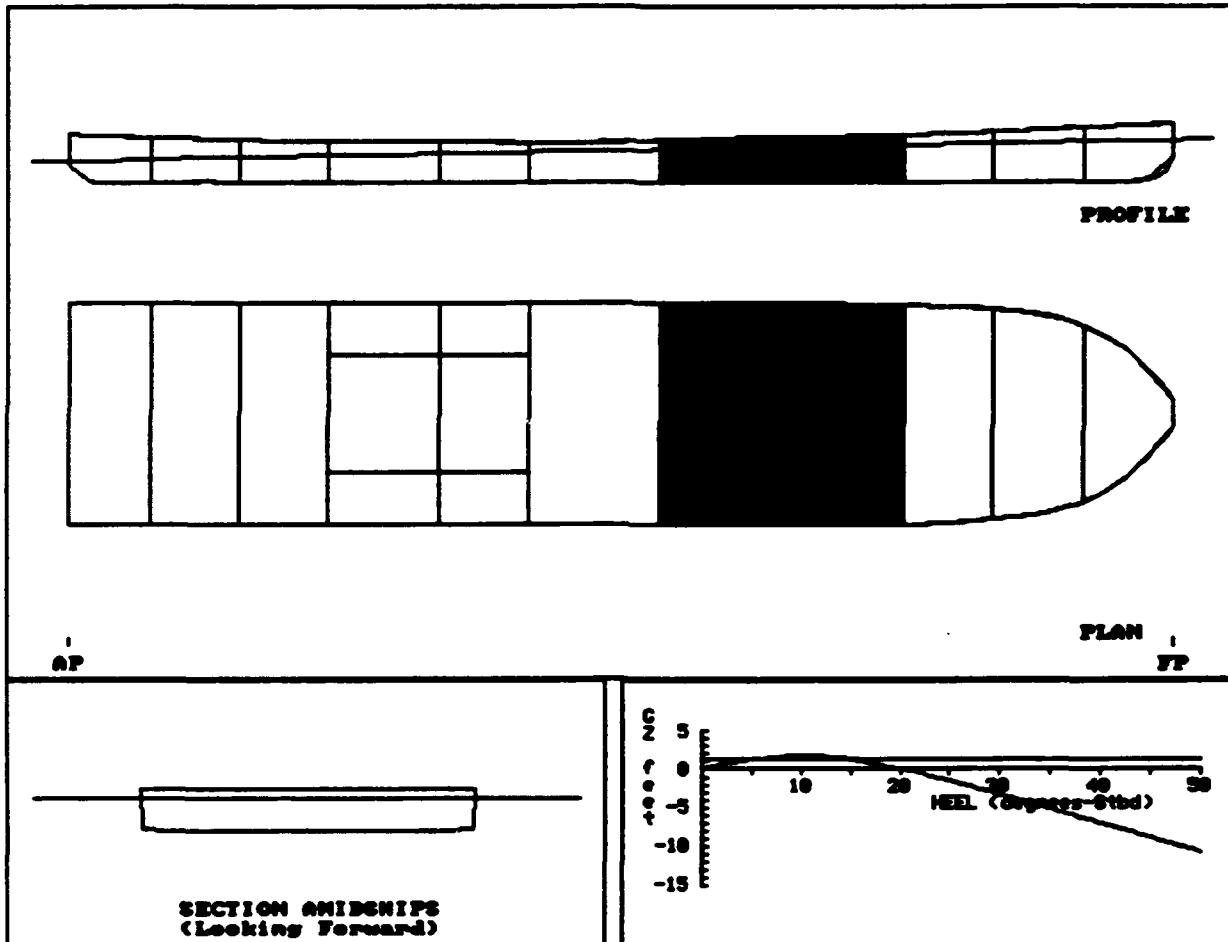

DPRT014A: OFFICE/LOUNGE 2
 198' CASINO BOAT

COMPARTMENT FLOODING SUMMARY

At 0.0o Heel	PERM.	FLOODED WTR LTons	% FULL (Damaged)	% FULL (Intact)	SP.VOL. ft ³ /LT	OUTFLOW LTons
OFFICES	0.95	327.9	FREE	0.0	----	----
LOUNGE/HEAD	0.95	322.4	FREE	0.0	----	----
Totals		650.4				

INTACT DATA

Draft at AP = 6.470 ft	KMt = 50.919 ft	LCG = 106.193A ft-FP
Draft at FP = 6.470 ft	VCG = 27.800 ft	LCB = 106.193A ft-FP
Displacement = 1837.5 LTons	GMT = 23.119 ft	TCG = 0.000 ft-CL

DRAFT/GZ DATA

HEEL degrees	RIGHTING ARM ft	DRAFT AFT ft	DRAFT FWD ft	FLOODED WATER LTons
0.00	0.000	6.035	11.419	650.4
5.00S	1.234	6.042	11.372	648.9
10.00S	1.807	6.091	11.610	632.9
15.00S	1.353	6.338	12.404	618.8
20.00S	0.139	6.729	13.513	606.2
25.00S	-1.484	7.131	14.818	596.6
30.00S	-3.283	7.547	16.297	589.5
35.00S	-5.148	7.990	17.982	584.2
40.00S	-7.024	8.481	19.919	580.1
50.00S	-10.679	9.701	24.934	574.5

Note: Drafts are measured at A.P. and F.P along ship's centerline

GZ SUMMARY (Evaluated per IMO (SOLAS'90) Rules for Passenger Ships)
 Available Required

Static Heel Angle	0.00 deg	7.00 deg
Freeboard to Downflooding	2.823 ft	
Angle at Maximum GZ	11.00S deg	
Maximum GZ	1.807 ft	1.340 ft
Range of Positive GZ	20.46 deg	15.00 deg
Gmt (upright damaged)	14.372 ft	
Righting Area (0.00-%.46)	23.448 ft-deg	2.820 ft-deg

DPRT015A: AC MACHY/H2O
 198' CASINO BOAT

Imaged Compartments:
 A/C MACHY FRESH H2O

	DISPLACEMENT LTons	DRAFT AFT ft	DRAFT FWD ft	TRIM ft	HEEL deg.	UPRIGHT GMT ft
INTACT	1,837.5	6.470	6.470	0.000	0.00	23.119
DAMAGED	1,886.9	6.905	6.296	0.609A	0.00	23.370

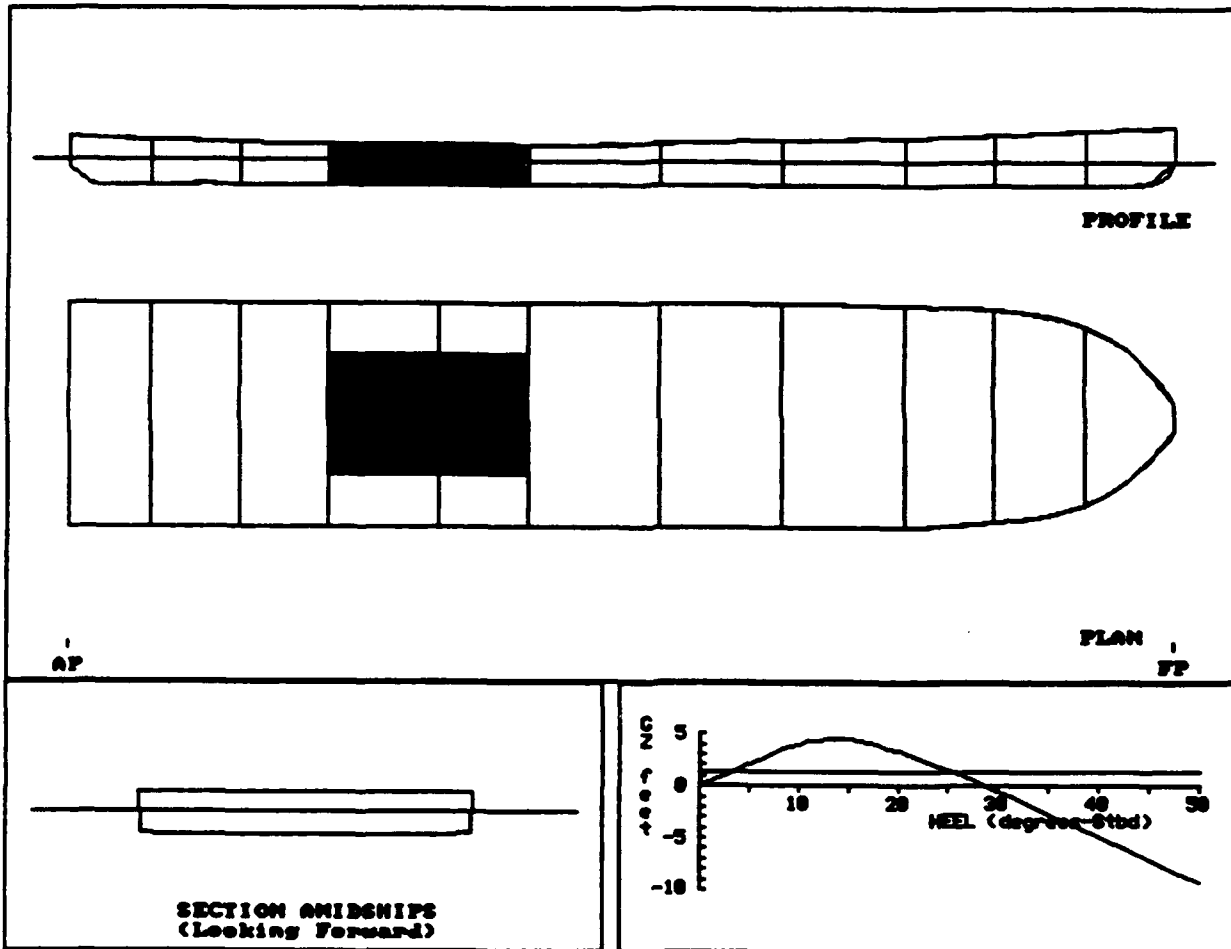

DFRT015A: AC MACHY/H2O
 198' CASINO BOAT

COMPARTMENT FLOODING SUMMARY

At 0.0o Heel	PERM.	FLOODED WTR LTons	% FULL (Damaged)	% FULL (Intact)	SP.VOL. ft3/LT	OUTFLOW LTons
A/C MACHY	0.85	104.3	FREE	0.0	----	----
FRESH H2O	0.95	92.5	FREE	100.0	35.8800	147.4
Totals		196.8				147.4

INTACT DATA

Draft at AP = 6.470 ft Kmt = 50.919 ft LCG = 106.193A ft-FP
 Draft at FP = 6.470 ft VCG = 27.800 ft LCB = 106.193A ft-FP
 Displacement = 1837.5 LTons Gmt = 23.119 ft TCG = 0.000 ft-CL

DRAFT/GZ DATA

HEEL degrees	RIGHTING ARM ft	DRAFT AFT ft	DRAFT FWD ft	FLOODED WATER LTons
0.00	0.000	6.905	6.296	196.8
5.00S	2.050	6.918	6.255	196.6
10.00S	3.995	6.928	6.168	196.0
15.00S	4.471	7.398	5.945	203.1
20.00S	3.342	8.009	5.658	207.2
25.00S	1.564	8.629	5.343	205.9
30.00S	-0.492	9.287	4.990	203.2
35.00S	-2.667	0.030	4.589	201.3
40.00S	-4.892	10.877	4.133	199.8
50.00S	-9.320	13.056	2.950	197.7

Note: Drafts are measured at A.P. and F.P along ship's centerline

GZ SUMMARY (Evaluated per IMO (SOLAS'90) Rules for Passenger Ships)
 Available Required

Static Heel Angle	0.00 deg	7.00 deg
Freeboard to Downflooding	4.790 ft	
Angle at Maximum GZ	15.00S deg	
Maximum GZ	4.523 ft	1.340 ft
Range of Positive GZ	28.84 deg	15.00 deg
Gmt (upright damaged)	23.370 ft	
Righting Area (0.00-4.00)	68.408 ft-deg	2.820 ft-deg

DPR016A: AC MACHY/ENG RM
 198' CASINO BOAT

Managed Compartments:

A/C MACHY ENG RM

	DISPLACEMENT LTons	DRAFT AFT ft	DRAFT FWD ft	TRIM ft	HEEL deg.	UPRIGHT GMT ft
INTACT	1,837.5	6.470	6.470	0.000	0.00	23.119
DAMAGED	2,155.4	8.968	5.708	3.260A	0.00	18.597

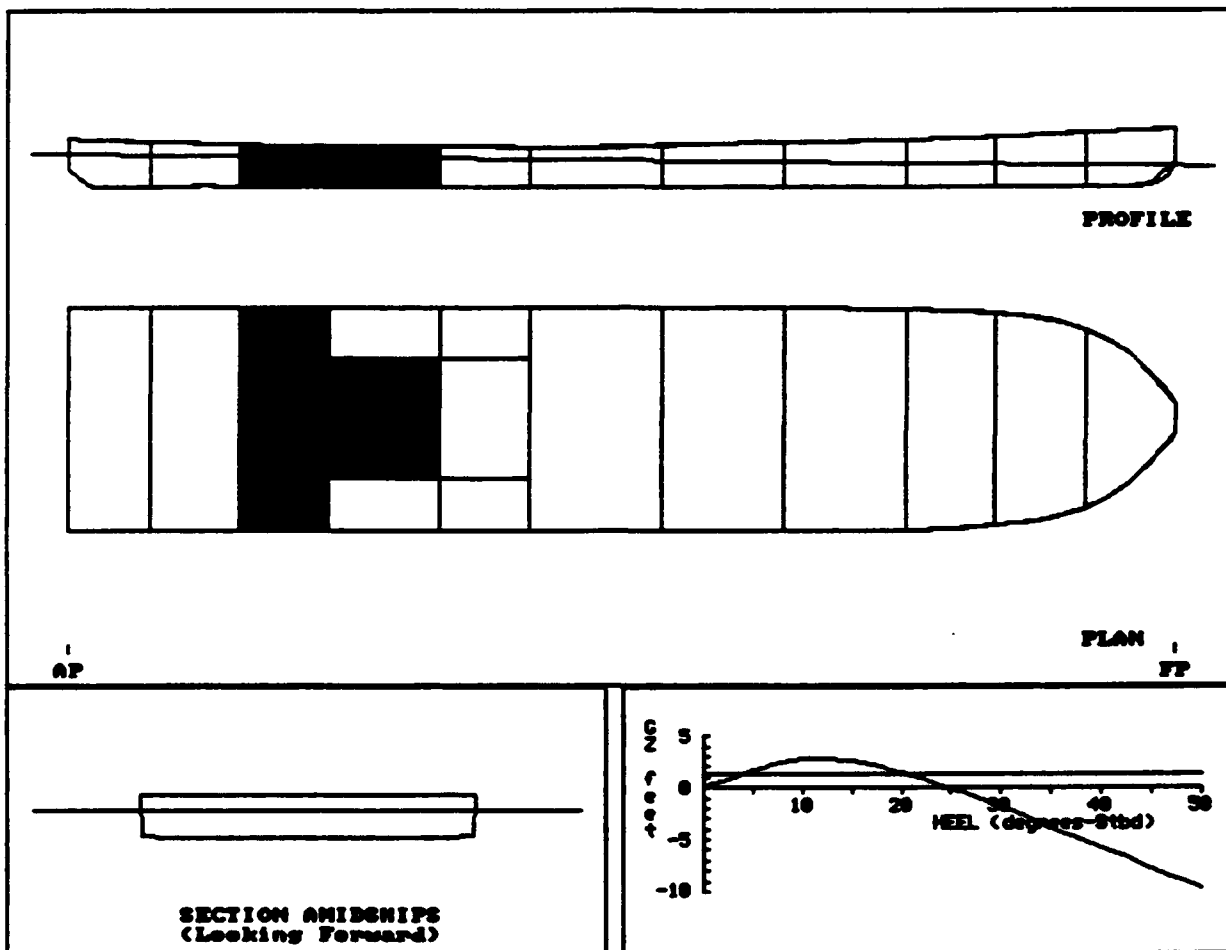

DPRT016A: AC MACHY/ENG RM
 198' CASINO BOAT

COMPARTMENT FLOODING SUMMARY

At 0.0o Heel	PERM.	FLOODED WTR LTons	% FULL (Damaged)	% FULL (Intact)	SP.VOL. ft ³ /LT	OUTFLOW LTons
A/C MACHY	0.85	124.6	FREE	0.0	----	----
ENG RM	0.85	193.3	FREE	0.0	----	----
Totals		317.9				

INTACT DATA

Draft at AP = 6.470 ft Kmt = 50.919 ft LCG = 106.193A ft-FP
 Draft at FP = 6.470 ft VCG = 27.800 ft LCB = 106.193A ft-FP
 Displacement = 1837.5 LTons GMT = 23.119 ft TCG = 0.000 ft-CL

DRAFT/GZ DATA

HEEL degrees	RIGHTING ARM ft	DRAFT AFT ft	DRAFT FWD ft	FLOODED WATER LTons
0.00	0.000	8.968	5.708	317.9
5.00S	1.635	9.002	5.647	318.4
10.00S	2.774	9.391	5.446	319.8
15.00S	2.587	10.682	4.971	327.8
20.00S	1.514	12.495	4.346	334.5
25.00S	-0.062	14.564	3.627	338.9
30.00S	-1.886	16.868	2.797	342.2
35.00S	-3.813	19.400	1.882	344.4
40.00S	-5.773	22.291	0.809	346.1
50.00S	-9.642	29.607	-1.927	348.1

Note: Drafts are measured at A.P. and F.P along ship's centerline

GZ SUMMARY (Evaluated per IMO (SOLAS'90) Rules for Passenger Ships)

	Available	Required
Static Heel Angle	0.00 deg	7.00 deg
Freeboard to Downflooding	3.134 ft	
Angle at Maximum GZ	13.00S deg	
Maximum GZ	2.852 ft	1.340 ft
Range of Positive GZ	24.82 deg	15.00 deg
Gmt (upright damaged)	18.597 ft	
Righting Area (0.00-3.00)	42.421 ft-deg	2.820 ft-deg

DPRT017A: AC MACHY/FUEL
 198' CASINO BOAT

Imaged Compartments:
 FUEL A/C MACHY

	DISPLACEMENT LTons	DRAFT AFT ft	DRAFT FWD ft	TRIM ft	HEEL deg.	UPRIGHT GMT ft
INTACT	1,837.5	6.470	6.470	0.000	0.00	23.119
DAMAGED	1,915.7	7.002	6.379	0.623A	0.90P	20.696

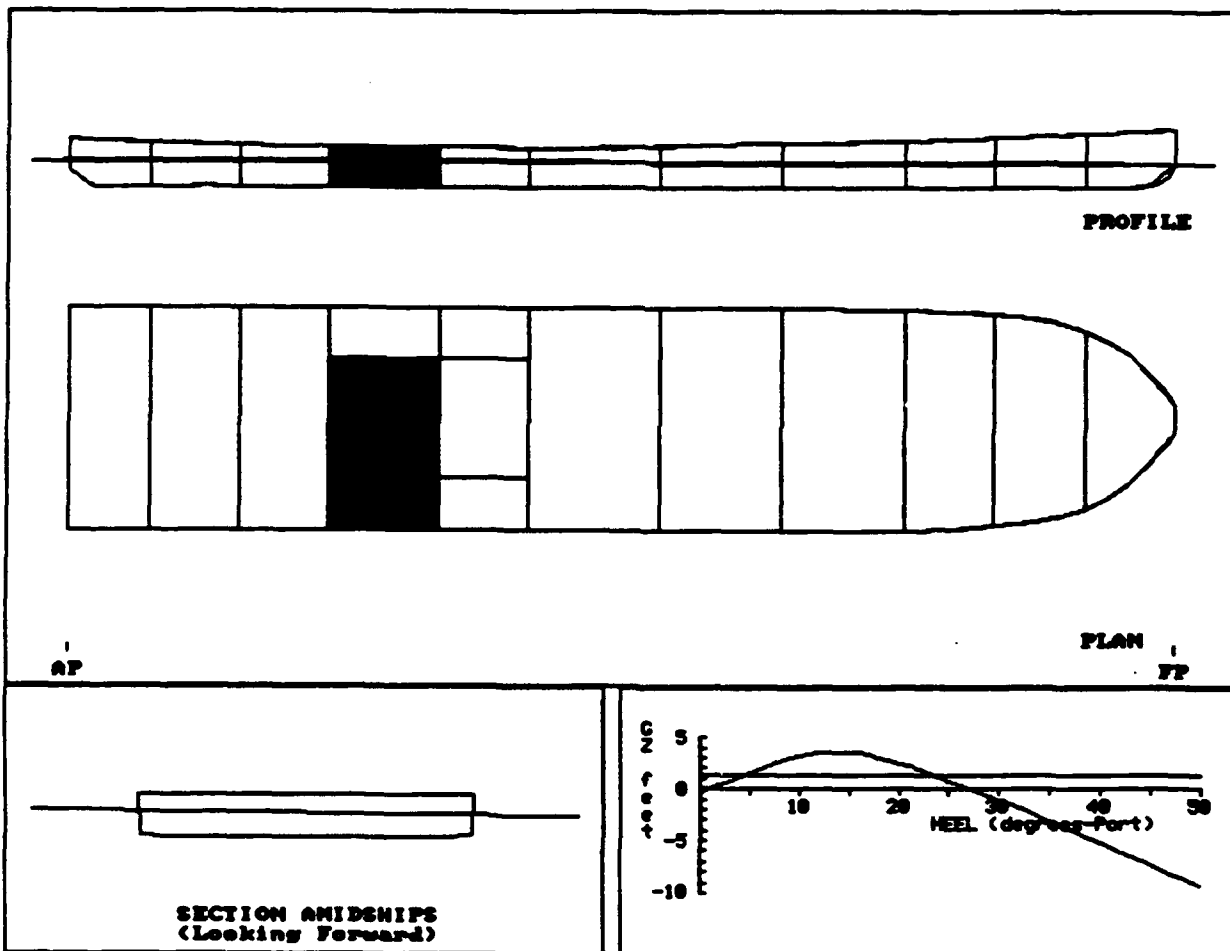

DPRT017A: AC MACHY/FUEL
 198' CASINO BOAT

COMPARTMENT FLOODING SUMMARY

At 0.90P Heel	PERM.	FLOODED WTR LTons	% FULL (Damaged)	% FULL (Intact)	SP.VOL. ft3/LT	OUTFLOW LTons
FUEL	0.95	49.0	FREE	100.0	38.5800	76.5
A/C MACHY	0.85	105.7	FREE	0.0	----	----
Totals		154.7				76.5

INTACT DATA

Draft at AP = 6.470 ft	KMt = 50.919 ft	LCG = 106.193A ft-FP
Draft at FP = 6.470 ft	VCG = 27.800 ft	LCB = 106.193A ft-FP
Displacement = 1837.5 LTons	GMT = 23.119 ft	TCG = 0.000 ft-CL

DRAFT/GZ DATA

HEEL degrees	RIGHTING ARM ft	DRAFT AFT ft	DRAFT FWD ft	FLOODED WATER LTons
0.00	-0.322	7.016	6.386	157.7
5.00P	1.493	6.928	6.348	140.7
10.00P	3.208	6.811	6.284	122.8
15.00P	3.601	7.011	6.159	111.0
20.00P	2.526	7.402	5.927	107.2
25.00P	0.862	7.837	5.686	105.4
30.00P	-1.061	8.330	5.413	104.2
35.00P	-3.105	8.885	5.105	103.5
40.00P	-5.197	9.518	4.754	102.9
50.00P	-9.359	11.145	3.849	102.0

Note: Drafts are measured at A.P. and F.P along ship's centerline

GZ SUMMARY (Evaluated per IMO (SOLAS'90) Rules for Passenger Ships)

	Available	Required
Static Heel Angle	0.90P deg	7.00 deg
Freeboard to Downflooding	5.165 ft	
Angle at Maximum GZ	15.00P deg	
Maximum GZ	3.655 ft	1.340 ft
Range of Positive GZ	26.40 deg	15.00 deg
Righting Area (0.90-7.00)	52.910 ft-deg	2.820 ft-deg

DPRT018A: AC/FUEL/ER
 198' CASINO BOAT

Imaged Compartments:

A/C MACHY FUEL (P) ENG RM

	DISPLACEMENT LTons	DRAFT AFT ft	DRAFT FWD ft	TRIM ft	HEEL deg.	UPRIGHT GMT ft
INTACT	1,837.5	6.470	6.470	0.000	0.00	23.119
DAMAGED	2,132.5	8.817	5.725	3.092A	0.71S	17.026

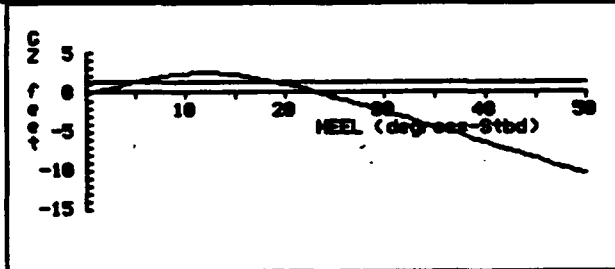
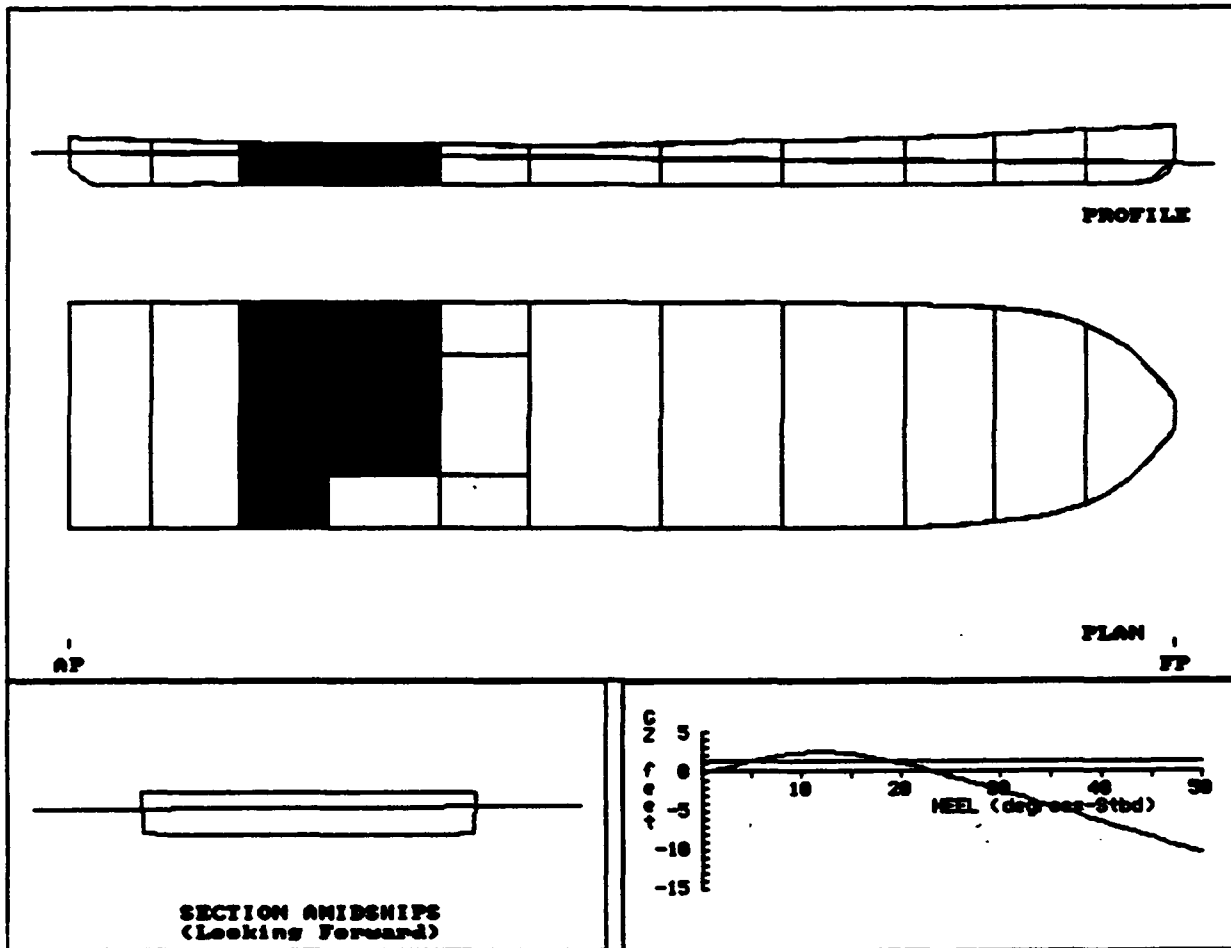

DPR018A: AC/FUEL/ER
 198' CASINO BOAT

COMPARTMENT FLOODING SUMMARY

At 0.7oS Heel	PERM.	FLOODED WTR LTons	% FULL (Damaged)	% FULL (Intact)	SP.VOL. ft3/LT	OUTFLOW LTons
A/C MACHY	0.85	123.0	FREE	0.0	----	----
FUEL (P)	0.95	58.0	FREE	100.0	38.5800	76.5
ENG RM	0.85	190.5	FREE	0.0	----	----
Totals		371.5				76.5

INTACT DATA

Draft at AP = 6.470 ft	KMt = 50.919 ft	LCG = 106.193A ft-FP
Draft at FP = 6.470 ft	VCG = 27.800 ft	LCB = 106.193A ft-FP
Displacement = 1837.5 LTons	GMT = 23.119 ft	TCG = 0.000 ft-CL

DRAFT/GZ DATA

HEEL degrees	RIGHTING ARM ft	DRAFT AFT ft	DRAFT FWD ft	FLOODED WATER LTons
0.00	-0.212	8.829	5.733	374.2
5.00S	1.284	8.745	5.677	355.3
10.00S	2.424	8.863	5.564	336.6
15.00S	2.260	9.839	5.159	329.6
20.00S	1.135	11.232	4.629	324.4
25.00S	-0.521	12.740	4.051	321.1
30.00S	-2.418	14.415	3.388	319.2
35.00S	-4.407	16.265	2.652	317.8
40.00S	-6.426	18.371	1.806	316.9
50.00S	-10.395	23.712	-0.340	315.6

Note: Drafts are measured at A.P. and F.P along ship's centerline

GZ SUMMARY (Evaluated per IMO (SOLAS'90) Rules for Passenger Ships)

	Available	Required
Static Heel Angle	0.71S deg	7.00 deg
Freeboard to Downflooding	2.888 ft	
Angle at Maximum GZ	13.00S deg	
Maximum GZ	2.517 ft	1.340 ft
Range of Positive GZ	22.82 deg	15.00 deg
Righting Area (0.71- λ .00)	35.054 ft-deg	2.820 ft-deg

RTRN001B: VOID THRUSTER
 198' CASINO BOAT

Managed Compartments:
 VOID THRUSTER RM

	DISPLACEMENT LTons	DRAFT AFT ft	DRAFT FWD ft	TRIM ft	HEEL deg.	UPRIGHT GMT ft
INTACT	1,777.9	6.280	6.280	0.000	0.00	23.932
DAMAGED	1,948.7	5.271	8.661	3.391F	0.00	22.230

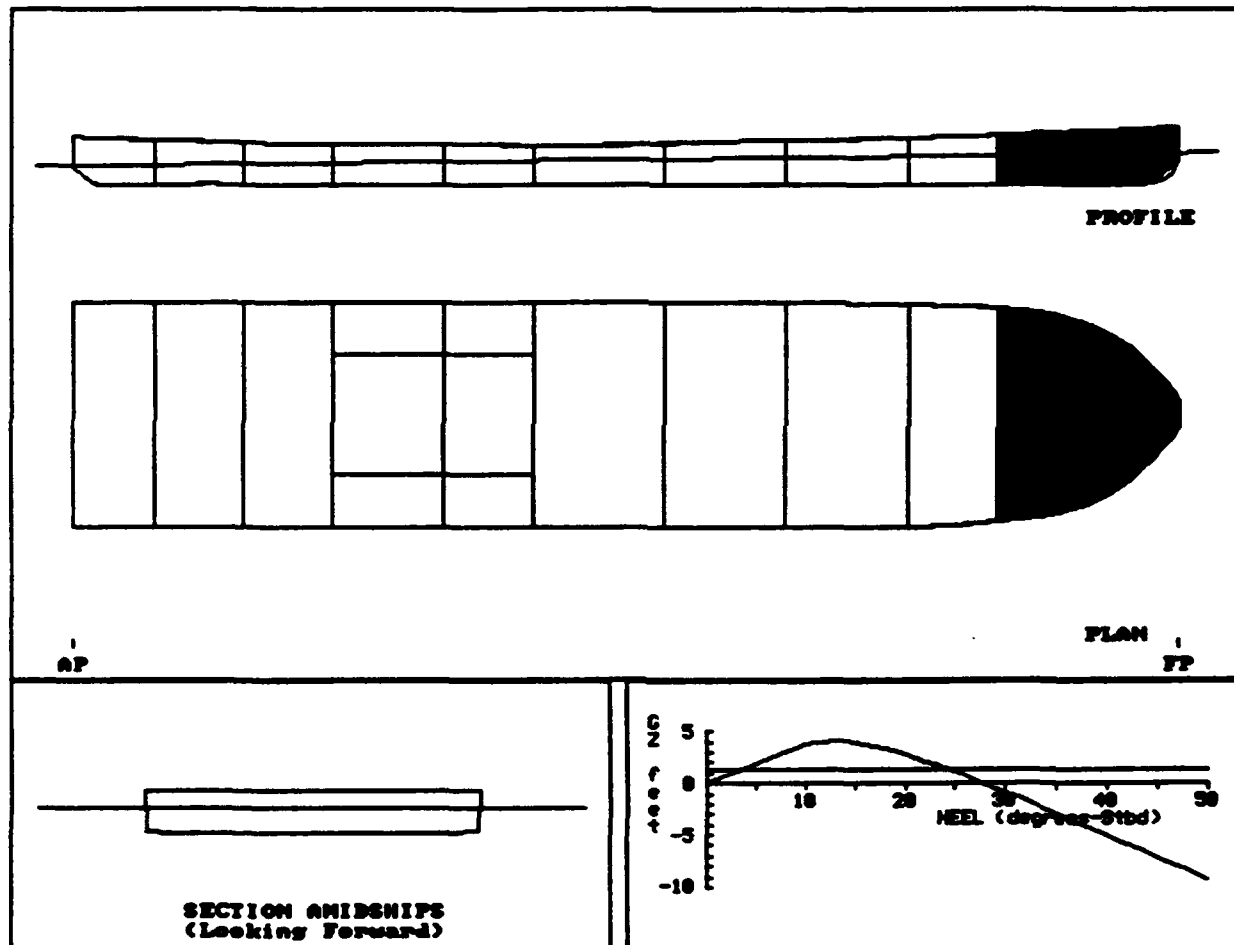

RTRN001B: VOID THRUSTER
 198' CASINO BOAT

COMPARTMENT FLOODING SUMMARY

At 0.0o Heel	PERM.	FLOODED WTR LTons	% FULL (Damaged)	% FULL (Intact)	SP.VOL. ft3/LT	OUTFLOW LTons
VOID	0.95	53.9	FREE	0.0	----	----
THRUSTER RM	0.85	116.9	FREE	0.0	----	----
Totals		170.8				

INTACT DATA

Draft at AP = 6.280 ft Kmt = 52.332 ft LCG = 106.130A ft-FP
 Draft at FP = 6.280 ft VCG = 28.400 ft LCB = 106.130A ft-FP
 Displacement = 1777.9 LTons Gmt = 23.932 ft TCG = 0.000 ft-CL

DRAFT/GZ DATA

HEEL degrees	RIGHTING ARM ft	DRAFT AFT ft	DRAFT FWD ft	FLOODED WATER LTons
0.00	0.000	5.271	8.661	170.8
5.00S	1.906	5.208	8.689	172.8
10.00S	3.694	5.062	8.780	179.3
15.00S	3.976	4.718	9.552	202.4
20.00S	2.812	4.205	10.693	223.9
25.00S	1.074	3.595	12.041	240.4
30.00S	-0.897	2.899	13.571	252.5
35.00S	-2.973	2.068	15.367	262.3
40.00S	-5.081	1.163	17.376	269.5
50.00S	-9.249	-1.125	22.482	279.7

Note: Drafts are measured at A.P. and F.P along ship's centerline

GZ SUMMARY (Evaluated per IMO (SOLAS'90) Rules for Passenger Ships)
 Available Required

Static Heel Angle	0.00 deg	7.00 deg
Freeboard to Downflooding	5.010 ft	
Angle at Maximum GZ	14.00S deg	
Maximum GZ	4.073 ft	1.380 ft
Range of Positive GZ	27.77 deg	15.00 deg
Gmt (upright damaged)	22.230 ft	
Righting Area (0.00-4.00)	61.279 ft-deg	2.820 ft-deg

RTRN002B: THRUSTER STOR1
 198' CASINO BOAT

Used Compartments:
 THRUSTER RM STORAGE

	DISPLACEMENT LTons	DRAFT AFT ft	DRAFT FWD ft	TRIM ft	HEEL deg.	UPRIGHT GMT ft
INTACT	1,777.9	6.280	6.280	0.000	0.00	23.932
DAMAGED	2,122.7	4.732	10.463	5.731F	0.00	19.143

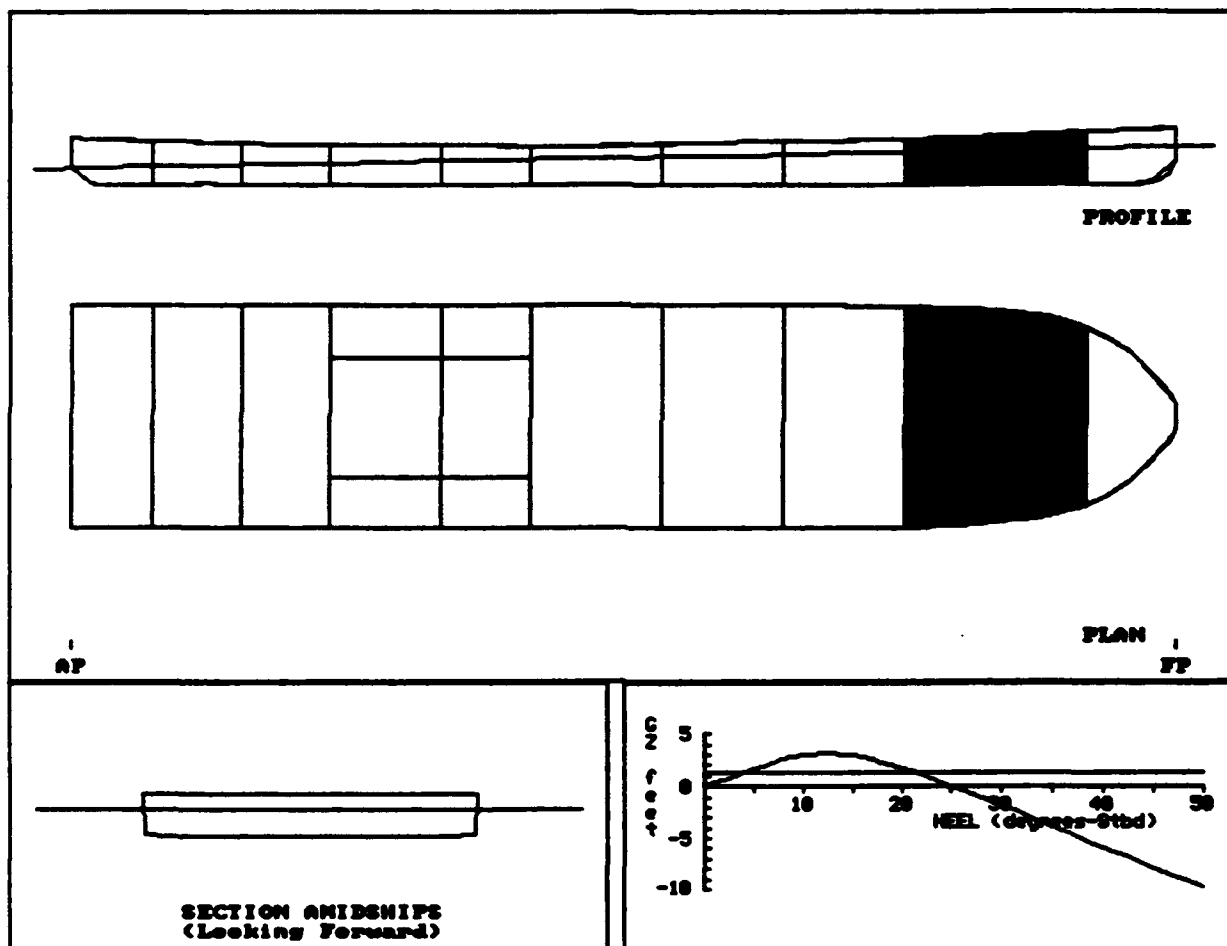

RTRN002B: THRUSTER STOR1
 198' CASINO BOAT

COMPARTMENT FLOODING SUMMARY

At 0.0o Heel	PERM.	FLOODED WTR LTons	% FULL (Damaged)	% FULL (Intact)	SP.VOL. ft3/LT	OUTFLOW LTons
THRUSTER RM	0.85	144.4	FREE	0.0	----	----
STORAGE	0.95	200.4	FREE	0.0	----	----
Totals		344.7				

INTACT DATA

Draft at AP = 6.280 ft	KMt = 52.332 ft	LCG = 106.130A ft-FP
Draft at FP = 6.280 ft	VCG = 28.400 ft	LCB = 106.130A ft-FP
Displacement = 1777.9 LTons	GMT = 23.932 ft	TCG = 0.000 ft-CL

DRAFT/GZ DATA

HEEL degrees	RIGHTING ARM ft	DRAFT AFT ft	DRAFT FWD ft	FLOODED WATER LTons
0.00	0.000	4.732	10.463	344.7
5.00S	1.660	4.643	10.512	347.9
10.00S	2.971	4.461	10.784	358.7
15.00S	2.924	4.071	11.878	374.0
20.00S	1.773	3.527	13.380	384.3
25.00S	0.077	2.868	15.145	391.8
30.00S	-1.843	2.120	17.145	397.3
35.00S	-3.857	1.259	19.437	401.9
40.00S	-5.898	0.273	22.080	405.8
50.00S	-9.919	-2.272	28.889	411.8

Note: Drafts are measured at A.P. and F.P along ship's centerline

GZ SUMMARY (Evaluated per IMO (SOLAS'90) Rules for Passenger Ships)

	Available	Required
Static Heel Angle	0.00 deg	7.00 deg
Freeboard to Downflooding	3.879 ft	
Angle at Maximum GZ	13.00S deg	
Maximum GZ	3.125 ft	1.380 ft
Range of Positive GZ	25.21 deg	15.00 deg
Gmt (upright damaged)	19.143 ft	
Righting Area (0.00-%.00)	46.398 ft-deg	2.820 ft-deg

RTRN003B: STOR1 OFFICE
 198' CASINO BOAT

Imaged Compartments:
 STORAGE TANKS

	DISPLACEMENT LTons	DRAFT AFT ft	DRAFT FWD ft	TRIM ft	HEEL deg.	UPRIGHT GMT ft
INTACT	1,777.9	6.280	6.280	0.000	0.00	23.932
DAMAGED	2,324.5	4.854	11.677	6.822F	0.00	16.382

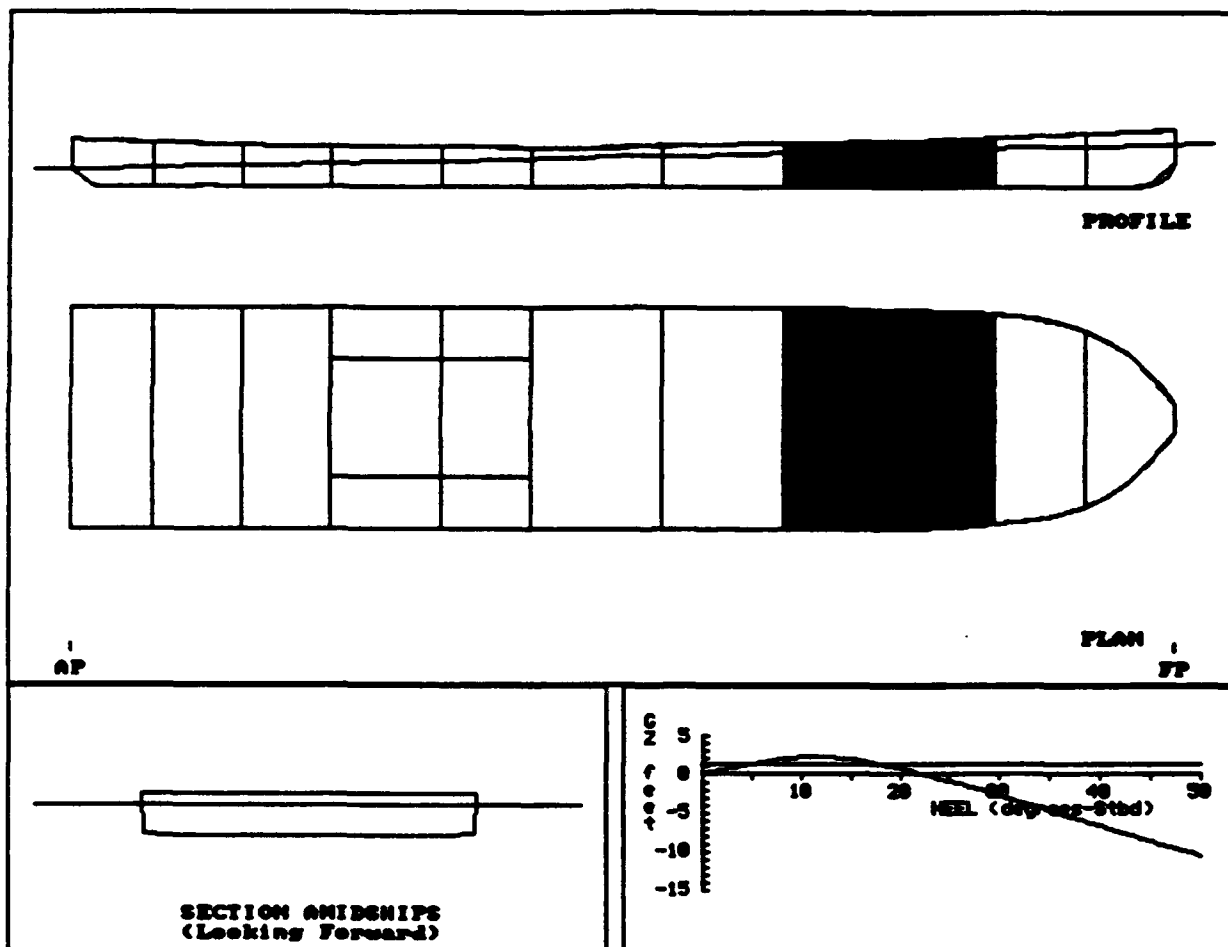

RTRN003B: STOR1 OFFICE
 198' CASINO BOAT

COMPARTMENT FLOODING SUMMARY

At 0.0o Heel	PERM.	FLOODED WTR LTons	% FULL (Damaged)	% FULL (Intact)	SP.VOL. ft3/LT	OUTFLOW LTons
STORAGE	0.95	224.6	FREE	0.0	----	----
OFFICES	0.95	321.9	FREE	0.0	----	----
Totals		546.5				

INTACT DATA

Draft at AP = 6.280 ft KMT = 52.332 ft LCG = 106.130A ft-FP
 Draft at FP = 6.280 ft VCG = 28.400 ft LCB = 106.130A ft-FP
 Displacement = 1777.9 LTons GMT = 23.932 ft TCG = 0.000 ft-CL

DRAFT/GZ DATA

HEEL degrees	RIGHTING ARM ft	DRAFT AFT ft	DRAFT FWD ft	FLOODED WATER LTons
0.00	0.000	4.854	11.677	546.5
5.00S	1.417	4.795	11.680	547.2
10.00S	2.295	4.697	11.980	541.7
15.00S	2.011	4.484	13.093	540.1
20.00S	0.818	4.204	14.639	538.6
25.00S	-0.866	3.825	16.483	537.6
30.00S	-2.749	3.384	18.557	536.8
35.00S	-4.714	2.863	20.928	536.4
40.00S	-6.694	2.264	23.645	536.1
50.00S	-10.562	0.808	30.544	535.3

Note: Drafts are measured at A.P. and F.P along ship's centerline

GZ SUMMARY (Evaluated per IMO (SOLAS'90) Rules for Passenger Ships)
 Available Required

Static Heel Angle	0.00 deg	7.00 deg
Freeboard to Downflooding	2.977 ft	
Angle at Maximum GZ	12.00S deg	
Maximum GZ	2.334 ft	1.380 ft
Range of Positive GZ	22.54 deg	15.00 deg
Gmt (upright damaged)	16.382 ft	
Righting Area (0.00-%.00)	32.852 ft-deg	2.820 ft-deg

OFFICE LOUNGE
 198' CASINO BOAT

arranged Compartments:
 OFFICES LOUNGE/HEAD

	DISPLACEMENT LTons	DRAFT AFT ft	DRAFT FWD ft	TRIM ft	HEEL deg.	UPRIGHT GMT ft
INTACT	1,777.9	6.280	6.280	0.000	0.00	23.932
DAMAGED	2,654.0	6.223	12.307	6.084F	0.00	12.415

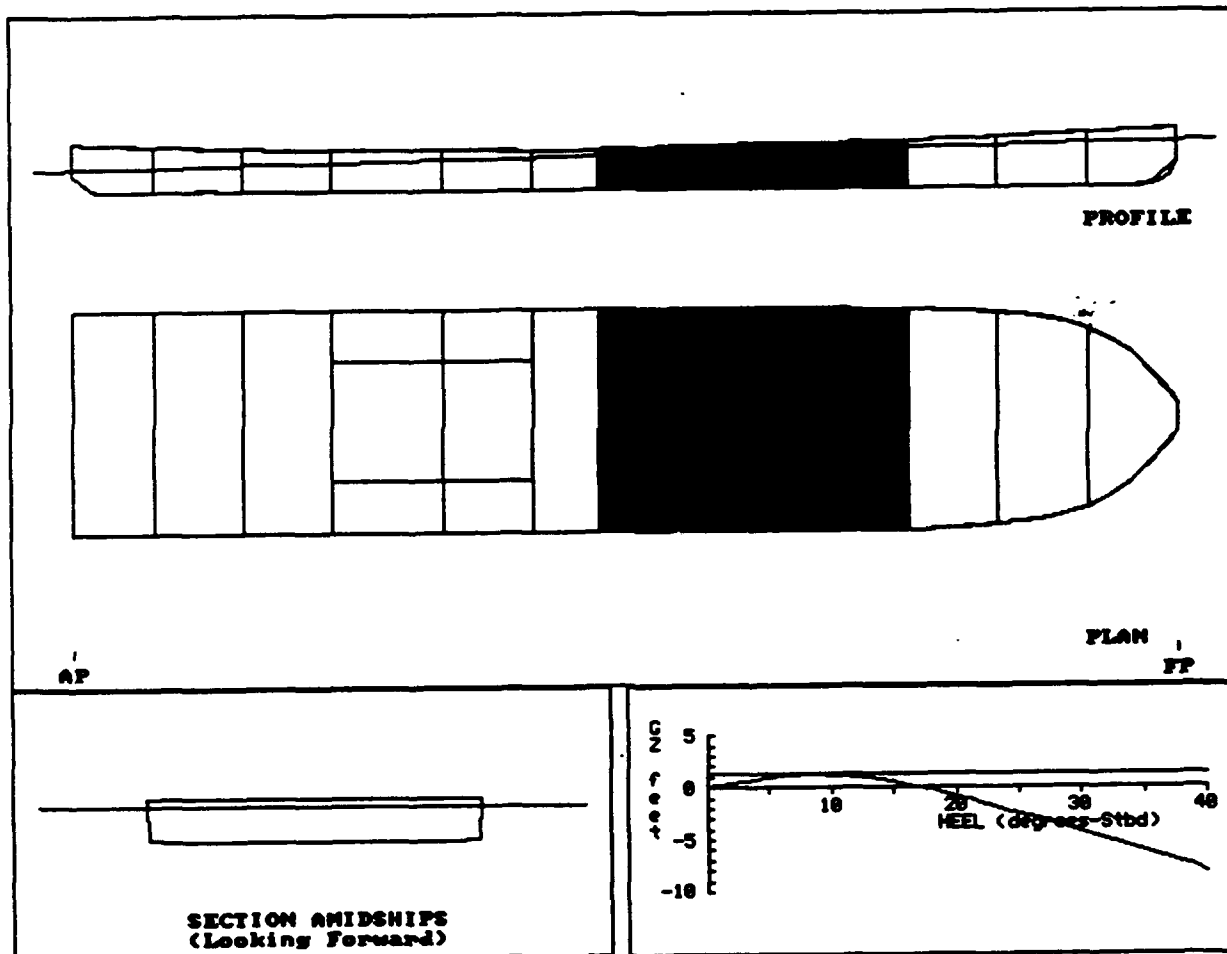

RTRN004B: OFFICE LOUNGE
 198' CASINO BOAT

Unaged Compartments:
 OFFICES LOUNGE/HEAD

	DISPLACEMENT LTons	DRAFT AFT ft	DRAFT FWD ft	TRIM ft	HEEL deg.	UPRIGHT GMT ft
INTACT	1,777.9	6.280	6.280	0.000	0.00	23.932
DAMAGED	2,409.4	5.848	11.109	5.261F	0.00	14.775

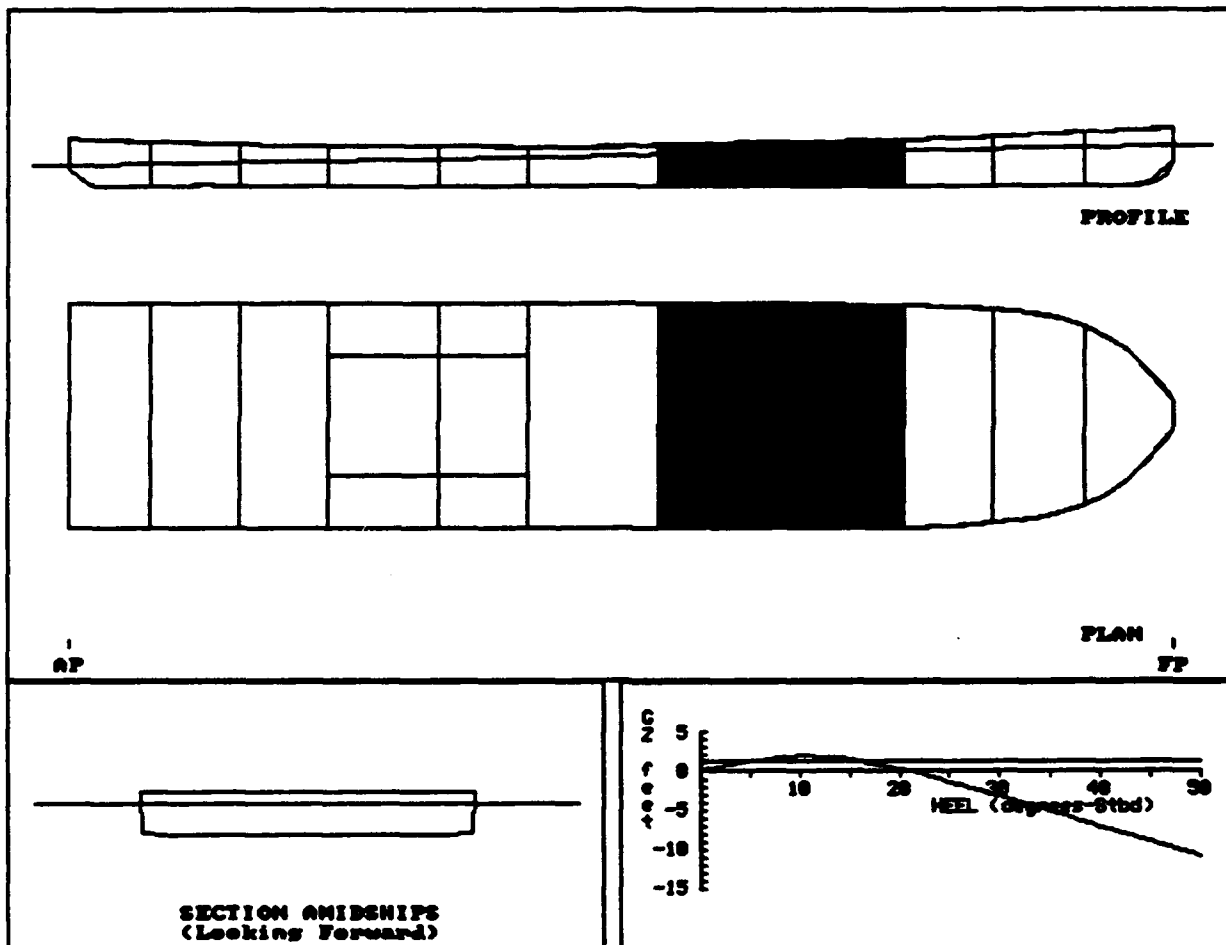

RTRN004B: OFFICE LOUNGE
 198' CASINO BOAT

COMPARTMENT FLOODING SUMMARY

At 0.0o Heel	PERM.	FLOODED WTR LTons	‡ FULL (Damaged)	‡ FULL (Intact)	SP.VOL. ft3/LT	OUTFLOW LTons
OFFICES	0.95	318.3	FREE	0.0	----	----
LOUNGE/HEAD	0.95	313.2	FREE	0.0	----	----
Totals		631.5				

INTACT DATA

Draft at AP = 6.280 ft KMT = 52.332 ft LCG = 106.130A ft-FP
 Draft at FP = 6.280 ft VCG = 28.400 ft LCB = 106.130A ft-FP
 Displacement = 1777.9 LTons GMT = 23.932 ft TCG = 0.000 ft-CL

DRAFT/GZ DATA

HEEL degrees	RIGHTING ARM ft	DRAFT AFT ft	DRAFT FWD ft	FLOODED WATER LTons
0.00	0.000	5.848	11.109	631.5
5.00S	1.269	5.845	11.066	630.2
10.00S	1.987	5.860	11.233	616.2
15.00S	1.627	6.040	11.943	601.5
20.00S	0.401	6.317	12.958	588.1
25.00S	-1.269	6.598	14.138	578.3
30.00S	-3.124	6.881	15.478	571.0
35.00S	-5.053	7.177	17.007	565.7
40.00S	-6.995	7.501	18.770	561.7
50.00S	-10.786	8.299	23.342	556.2

Note: Drafts are measured at A.P. and F.P along ship's centerline

GZ SUMMARY (Evaluated per IMO (SOLAS'90) Rules for Passenger Ships)
 Available Required

Static Heel Angle	0.00 deg	7.00 deg
Freeboard to Downflooding	3.098 ft	
Angle at Maximum GZ	12.00S deg	
Maximum GZ	2.004 ft	1.380 ft
Range of Positive GZ	21.28 deg	15.00 deg
Gmt (upright damaged)	14.775 ft	
Righting Area (0.00-‡.28)	26.805 ft-deg	2.820 ft-deg

RTRM005B: LONGE STOR2
 198' CASINO BOAT

Imaged Compartments:
 LOUNGE/HEAD STORES2

	DISPLACEMENT LTons	DRAFT AFT ft	DRAFT FWD ft	TRIM ft	HEEL deg.	UPRIGHT GMT ft
INTACT	1,777.9	6.280	6.280	0.000	0.00	23.932
DAMAGED	2,396.2	7.304	9.337	2.033F	0.00	13.284

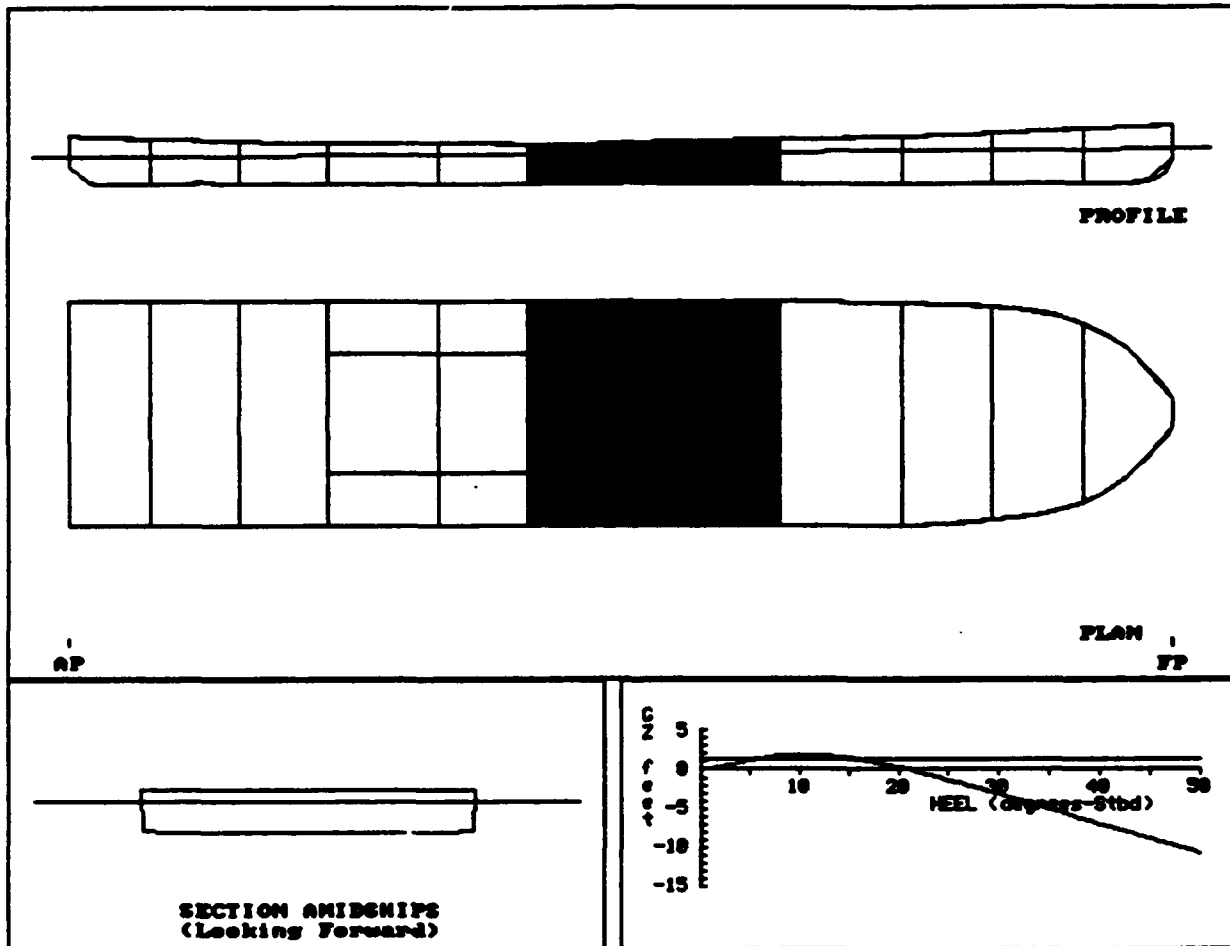

RTRM005B: LONGE STOR2
 198' CASINO BOAT

COMPARTMENT FLOODING SUMMARY

At 0.0o Heel	PERM.	FLOODED WTR LTons	% FULL (Damaged)	% FULL (Intact)	SP.VOL. ft3/LT	OUTFLOW LTons
LOUNGE/HEAD	0.95	297.0	FREE	0.0	----	----
STORES2	0.95	321.2	FREE	0.0	----	----
Totals		618.2				

INTACT DATA

Draft at AP = 6.280 ft KMT = 52.332 ft LCG = 106.130A ft-FP
 Draft at FP = 6.280 ft VCG = 28.400 ft LCB = 106.130A ft-FP
 Displacement = 1777.9 LTons GMT = 23.932 ft TCG = 0.000 ft-CL

DRAFT/GZ DATA

HEEL degrees	RIGHTING ARM ft	DRAFT AFT ft	DRAFT FWD ft	FLOODED WATER LTons
0.00	0.000	7.304	9.337	618.2
5.00S	1.168	7.322	9.284	616.9
10.00S	1.925	7.468	9.247	598.5
15.00S	1.520	8.112	9.427	576.8
20.00S	0.320	9.024	9.775	559.6
25.00S	-1.329	9.984	10.216	548.2
30.00S	-3.158	11.028	10.734	540.8
35.00S	-5.063	12.193	11.329	535.7
40.00S	-6.987	13.518	12.015	531.9
50.00S	-10.754	16.892	13.782	526.4

Note: Drafts are measured at A.P. and F.P along ship's centerline

GZ SUMMARY (Evaluated per IMO (SOLAS'90) Rules for Passenger Ships)
 Available Required

Static Heel Angle	0.00 deg	7.00 deg
Freeboard to Downflooding	3.946 ft	
Angle at Maximum GZ	12.00S deg	
Maximum GZ	1.939 ft	1.380 ft
Range of Positive GZ	21.05 deg	15.00 deg
Gmt (upright damaged)	13.284 ft	
Righting Area (0.00-1.05)	25.088 ft-deg	2.820 ft-deg

RTRN006B: STOR2 BLKH20(S)
 198' CASINO BOAT

Imaged Compartments:
 STORES2 BLACK WATER

	DISPLACEMENT LTons	DRAFT AFT ft	DRAFT FWD ft	TRIM ft	HEEL deg.	UPRIGHT GMT ft
INTACT	1,777.9	6.280	6.280	0.000	0.00	23.932
DAMAGED	2,026.4	6.918	7.250	0.332F	1.10P	16.501

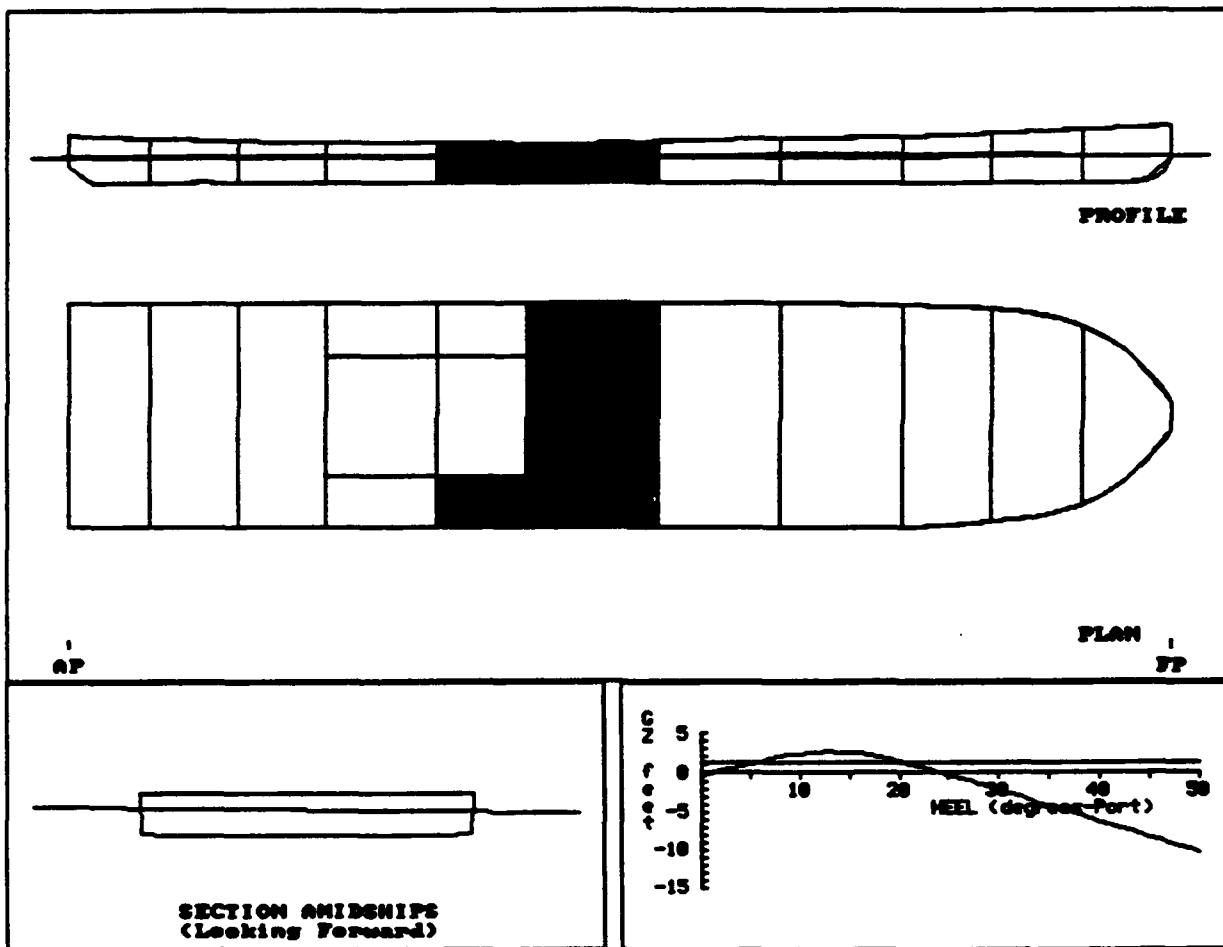

RTRN006B: STOR2 BLK20(S)
 198' CASINO BOAT

COMPARTMENT FLOODING SUMMARY

At 1.10P Heel	PERM.	FLOODED WTR LTons	% FULL (Damaged)	% FULL (Intact)	SP.VOL. ft3/LT	OUTFLOW LTons
STORES2	0.95	274.5	FREE	0.0	----	----
BLACK WATER	0.95	40.0	FREE	100.0	35.0063	66.0
Totals		314.5				66.0

INTACT DATA

Draft at AP = 6.280 ft Kmt = 52.332 ft LCG = 106.130A ft-FP
 Draft at FP = 6.280 ft VCG = 28.400 ft LCB = 106.130A ft-FP
 Displacement = 1777.9 LTons GMT = 23.932 ft TCG = 0.000 ft-CL

DRAFT/GZ DATA

HEEL degrees	RIGHTING ARM ft	DRAFT AFT ft	DRAFT FWD ft	FLOODED WATER LTons
0.00	-0.313	6.926	7.265	317.8
5.00P	1.134	6.881	7.191	302.9
10.00P	2.470	6.818	7.086	283.0
15.00P	2.626	7.054	7.002	258.4
20.00P	1.485	7.458	6.892	245.5
25.00P	-0.192	7.912	6.824	239.9
30.00P	-2.110	8.434	6.751	237.0
35.00P	-4.140	9.015	6.675	235.0
40.00P	-6.210	9.677	6.588	233.4
50.00P	-10.304	11.341	6.389	231.1

Note: Drafts are measured at A.P. and F.P along ship's centerline

GZ SUMMARY (Evaluated per IMO (SOLAS'90) Rules for Passenger Ships)
 Available Required

Static Heel Angle	1.10P deg	7.00 deg
Freeboard to Downflooding	5.205 ft	
Angle at Maximum GZ	14.00P deg	
Maximum GZ	2.740 ft	1.380 ft
Range of Positive GZ	23.37 deg	15.00 deg
Righting Area (1.10-4.00)	37.773 ft-deg	2.820 ft-deg

RTRN007B: STOR2 BLK20(P)
 198' CASINO BOAT

Imaged Compartments:
 STORES2 BLACK N20(P)

	DISPLACEMENT LTons	DRAFT AFT ft	DRAFT FWD ft	TRIM ft	HEEL deg.	UPRIGHT GMT ft
INTACT	1,777.9	6.280	6.280	0.000	0.00	23.932
DAMAGED	2,026.4	6.918	7.250	0.332F	1.10S	16.501

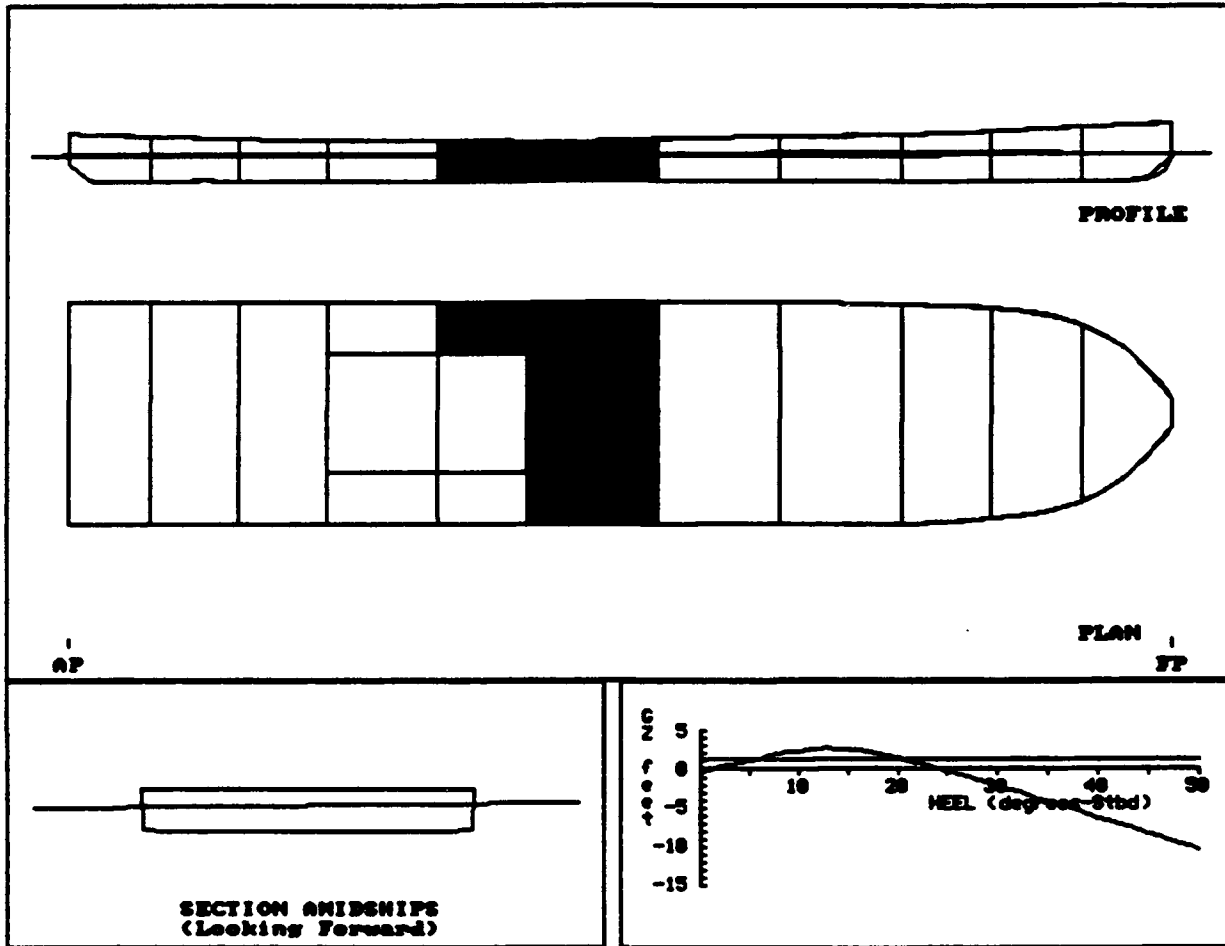

RTR007B: STOR2 BLK20(P)
 198' CASINO BOAT

COMPARTMENT FLOODING SUMMARY

At 1.1oS Heel	PERM.	FLOODED WTR LTons	% FULL (Damaged)	% FULL (Intact)	SP.VOL. ft3/LT	OUTFLOW LTons
STORES2	0.95	274.5	FREE	0.0	----	----
BLACK H2O(P)	0.95	40.0	FREE	100.0	35.0063	66.1
Totals		314.5				66.1

INTACT DATA

Draft at AP = 6.280 ft	Kmt = 52.332 ft	LCG = 106.130A ft-FP
Draft at FP = 6.280 ft	VCG = 28.400 ft	LCB = 106.130A ft-FP
Displacement = 1777.9 LTons	Gmt = 23.932 ft	TCG = 0.000 ft-CL

DRAFT/GZ DATA

HEEL degrees	RIGHTING ARM ft	DRAFT AFT ft	DRAFT FWD ft	FLOODED WATER LTons
0.00	-0.314	6.926	7.265	317.7
5.00S	1.134	6.880	7.191	302.9
10.00S	2.469	6.818	7.086	283.0
15.00S	2.626	7.053	7.002	258.4
20.00S	1.485	7.457	6.892	245.5
25.00S	-0.193	7.912	6.824	239.9
30.00S	-2.110	8.433	6.751	237.0
35.00S	-4.140	9.014	6.675	235.0
40.00S	-6.210	9.676	6.588	233.4
50.00S	-10.304	11.340	6.389	231.1

Note: Drafts are measured at A.P. and F.P along ship's centerline

GZ SUMMARY (Evaluated per IMO (SOLAS'90) Rules for Passenger Ships)
 Available Required

Static Heel Angle	1.10S deg	7.00 deg
Freeboard to Downflooding	4.057 ft	
Angle at Maximum GZ	14.00S deg	
Maximum GZ	2.740 ft	1.380 ft
Range of Positive GZ	23.37 deg	15.00 deg
Righting Area (1.10-4.00)	37.767 ft-deg	2.820 ft-deg

RTRN008B: BLK20/FUEL (S)
 198' CASINO BOAT

Managed Compartments:
 BLACK WATER FUEL

	DISPLACEMENT LTons	DRAFT AFT ft	DRAFT FWD ft	TRIM ft	HEEL deg.	UPRIGHT GMT ft
INTACT	1,777.9	6.280	6.280	0.000	0.00	23.932
DAMAGED	1,793.6	6.424	6.217	0.208A	0.50S	19.886

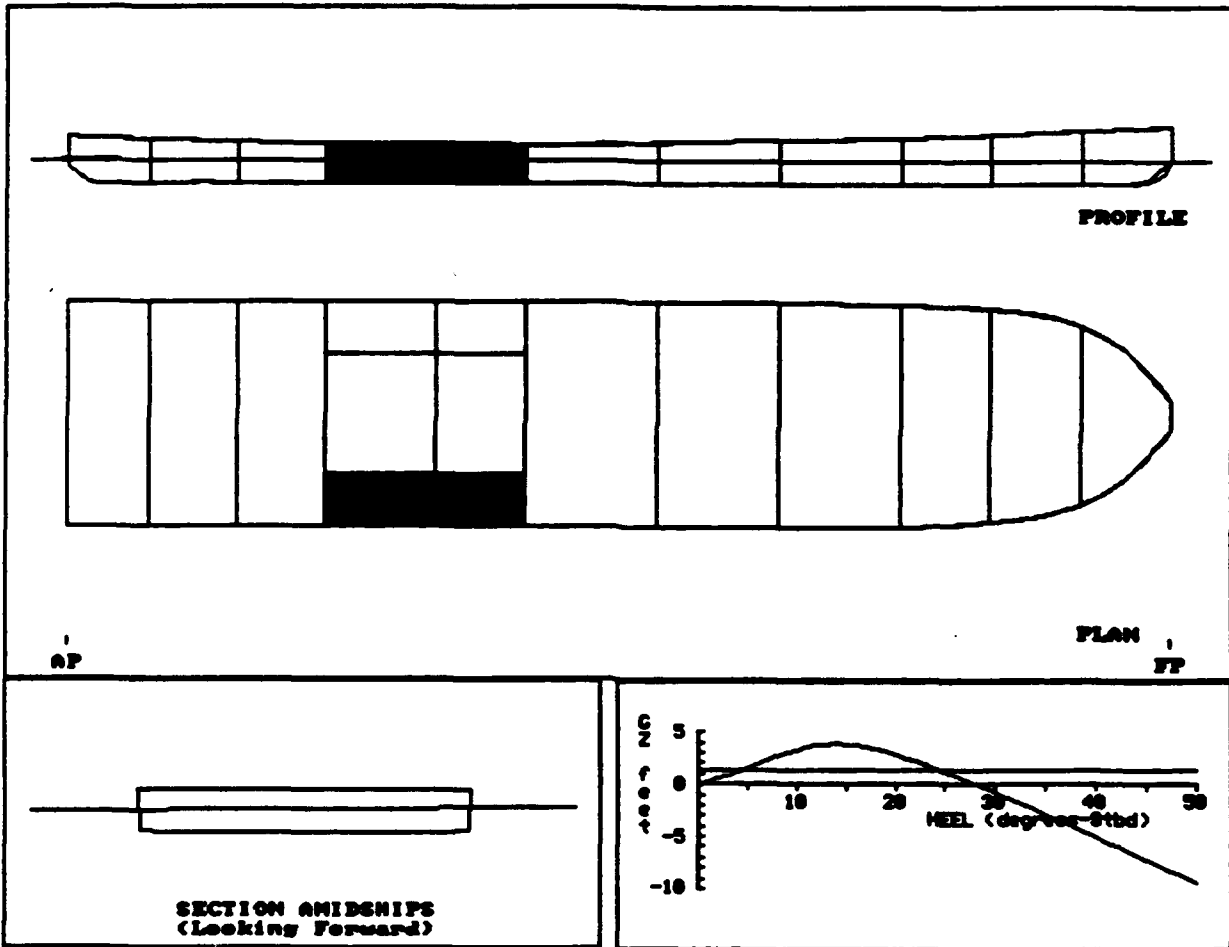

RTRN008B: BLK20/FUEL (S)
 198' CASINO BOAT

COMPARTMENT FLOODING SUMMARY

At 0.5oS Heel	PERM.	FLOODED WTR LTons	% FULL (Damaged)	% FULL (Intact)	SP.VOL. ft3/LT	OUTFLOW LTons
BLACK WATER	0.95	39.7	FREE	100.0	35.0063	66.0
FUEL	0.95	49.7	FREE	10.0	38.5800	7.6
Totals		89.4				73.7

INTACT DATA

Draft at AP = 6.280 ft	KMt = 52.332 ft	LCG = 106.130A ft-FP
Draft at FP = 6.280 ft	VCG = 28.400 ft	LCB = 106.130A ft-FP
Displacement = 1777.9 LTons	GMT = 23.932 ft	TCG = 0.000 ft-CL

DRAFT/GZ DATA

HEEL degrees	RIGHTING ARM ft	DRAFT AFT ft	DRAFT FWD ft	FLOODED WATER LTons
0.00	-0.173	6.406	6.219	86.5
5.00S	1.573	6.579	6.190	115.5
10.00S	3.274	6.733	6.107	142.6
15.00S	3.835	7.151	5.854	150.3
20.00S	2.838	7.610	5.564	150.3
25.00S	1.167	8.131	5.235	150.3
30.00S	-0.800	8.715	4.865	150.3
35.00S	-2.903	9.376	4.442	150.3
40.00S	-5.065	10.129	3.961	150.3
50.00S	-9.381	12.065	2.716	150.3

Note: Drafts are measured at A.P. and F.P along ship's centerline

GZ SUMMARY (Evaluated per IMO (SOLAS'90) Rules for Passenger Ships)
 Available Required

Static Heel Angle	0.50S deg	7.00 deg
Freeboard to Downflooding	4.946 ft	
Angle at Maximum GZ	15.00S deg	
Maximum GZ	3.855 ft	1.380 ft
Range of Positive GZ	27.53 deg	15.00 deg
Righting Area (0.50-1.00)	56.458 ft-deg	2.820 ft-deg

RTRM009B: BLK20/FUEL(P)
 198' CASINO BOAT

Imaged Compartments:
 BLACK H2O(P) FUEL (P)

	DISPLACEMENT LTons	DRAFT AFT ft	DRAFT FWD ft	TRIM ft	HEEL deg.	UPRIGHT Gmt ft
INTACT	1,777.9	6.280	6.280	0.000	0.00	23.932
DAMAGED	1,793.6	6.424	6.217	0.207A	0.50P	19.887

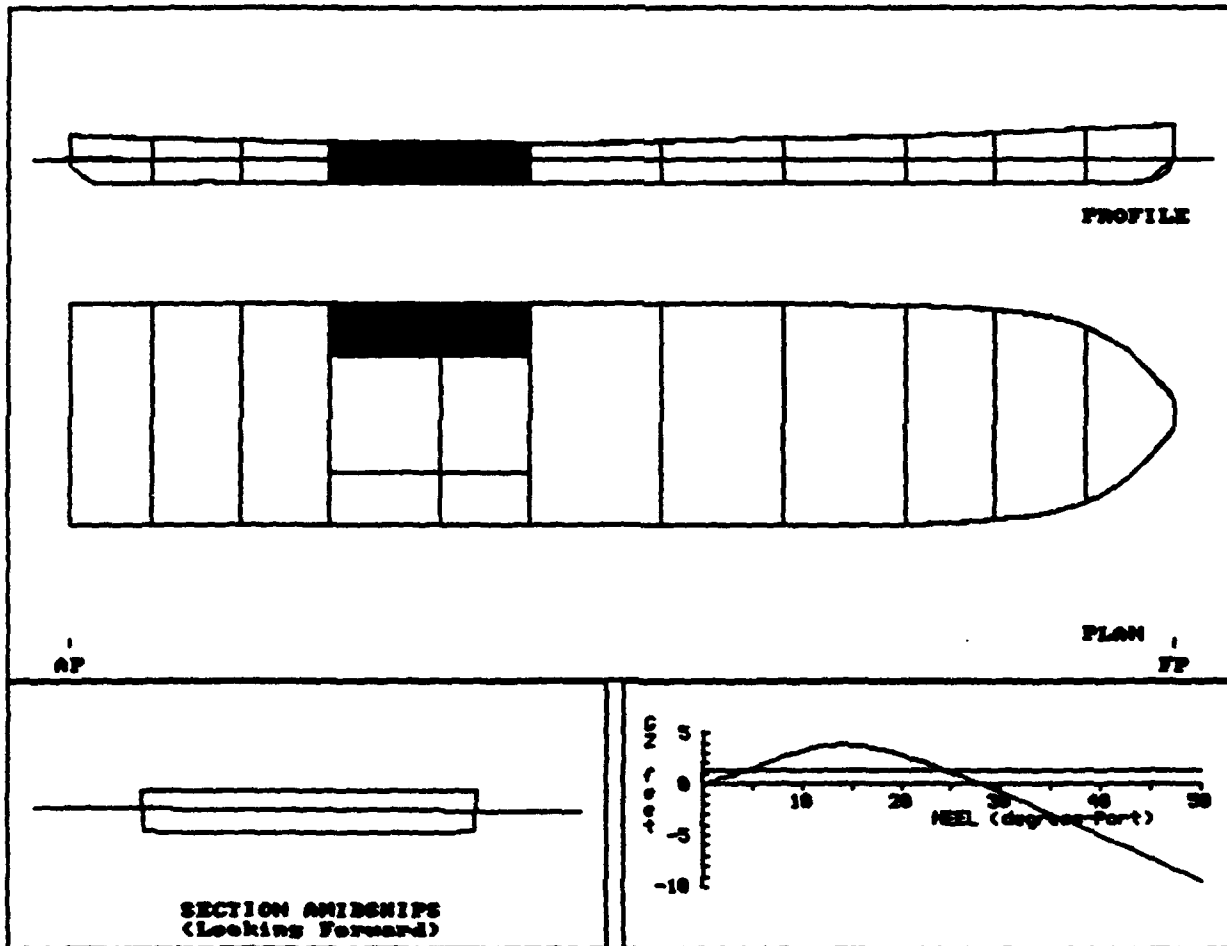

RTRN009B: BLK H2O/FUEL(P)
 198' CASINO BOAT

COMPARTMENT FLOODING SUMMARY

At 0.50P Heel	PERM.	FLOODED WTR LTons	% FULL (Damaged)	% FULL (Intact)	SP.VOL. ft ³ /LT	OUTFLOW LTons
BLACK H2O(P)	0.95	39.6	FREE	100.0	35.0063	66.1
FUEL (P)	0.95	49.7	FREE	10.0	38.5800	7.6
Totals		89.4				73.7

INTACT DATA

Draft at AP = 6.280 ft KMT = 52.332 ft LCG = 106.130A ft-FP
 Draft at FP = 6.280 ft VCG = 28.400 ft LCB = 106.130A ft-FP
 Displacement = 1777.9 LTons GMT = 23.932 ft TCG = 0.000 ft-CL

DRAFT/GZ DATA

HEEL degrees	RIGHTING ARM ft	DRAFT AFT ft	DRAFT FWD ft	FLOODED WATER LTons
0.00	-0.172	6.406	6.219	86.5
5.00P	1.574	6.579	6.190	115.5
10.00P	3.274	6.733	6.107	142.7
15.00P	3.834	7.152	5.854	150.4
20.00P	2.837	7.611	5.564	150.4
25.00P	1.166	8.132	5.234	150.4
30.00P	-0.800	8.717	4.864	150.4
35.00P	-2.904	9.378	4.441	150.4
40.00P	-5.066	10.130	3.961	150.4
50.00P	-9.382	12.067	2.715	150.4

Note: Drafts are measured at A.P. and F.P along ship's centerline

GZ SUMMARY (Evaluated per IMO (SOLAS'90) Rules for Passenger Ships)
 Available Required

Static Heel Angle	0.50P deg	7.00 deg
Freeboard to Downflooding	5.470 ft	
Angle at Maximum GZ	15.00P deg	
Maximum GZ	3.855 ft	1.380 ft
Range of Positive GZ	27.53 deg	15.00 deg
Righting Area (0.50- \pm .00)	56.456 ft-deg	2.820 ft-deg

RTRN010B: FUEL(S)/ENG RM
 198' CASINO BOAT

Imaged Compartments:
 FUEL ENG RM

	DISPLACEMENT LTons	DRAFT AFT ft	DRAFT FWD ft	TRIM ft	HEEL deg.	UPRIGHT GMT ft
INTACT	1,777.9	6.280	6.280	0.000	0.00	23.932
DAMAGED	2,011.3	8.184	5.629	2.556A	2.07S	17.445

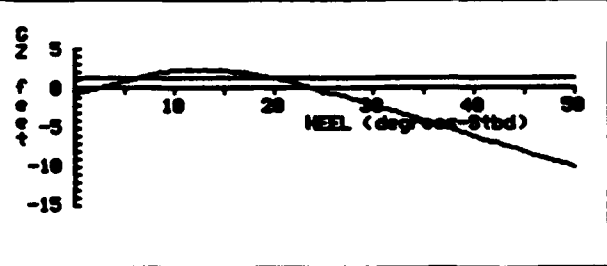
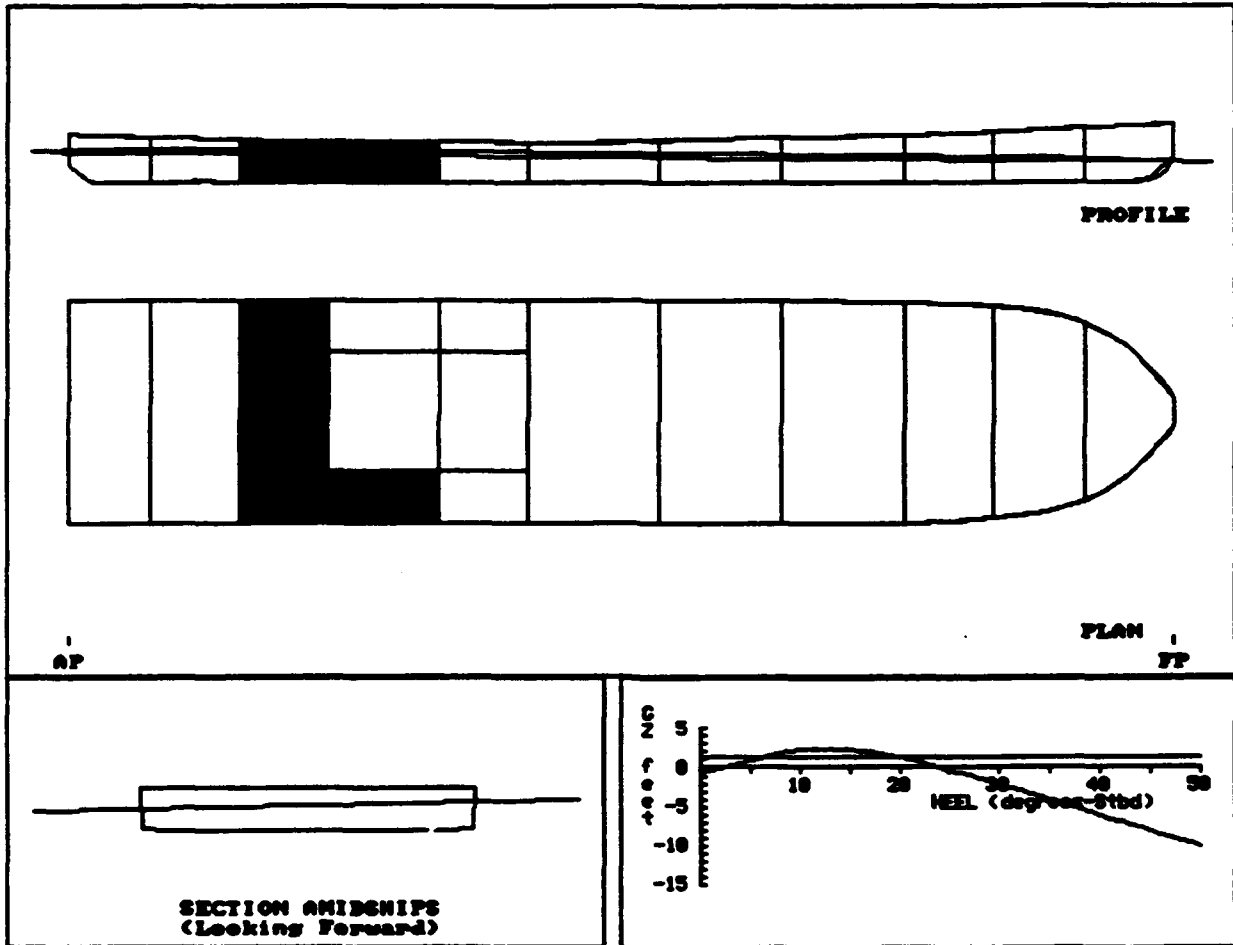

RTRN010B: FUEL(S)/ENG RM
 198' CASINO BOAT

COMPARTMENT FLOODING SUMMARY

At 2.1oS Heel	PERM.	FLOODED WTR LTons	% FULL (Damaged)	% FULL (Intact)	SP.VOL. ft3/LT	OUTFLOW LTons
FUEL	0.95	62.8	FREE	10.0	38.5800	7.6
ENG RM	0.85	178.2	FREE	0.0	----	----
Totals		241.0				7.6

INTACT DATA

Draft at AP = 6.280 ft	KMT = 52.332 ft	LCG = 106.130A ft-FP
Draft at FP = 6.280 ft	VCG = 28.400 ft	LCB = 106.130A ft-FP
Displacement = 1777.9 LTons	GMT = 23.932 ft	TCG = 0.000 ft-CL

DRAFT/GZ DATA

HEEL degrees	RIGHTING ARM ft	DRAFT AFT ft	DRAFT FWD ft	FLOODED WATER LTons
0.00	-0.632	8.131	5.647	233.5
5.00S	0.907	8.265	5.592	251.7
10.00S	2.243	8.575	5.396	263.3
15.00S	2.346	9.516	4.967	262.4
20.00S	1.345	10.845	4.396	261.2
25.00S	-0.257	12.261	3.773	260.2
30.00S	-2.118	13.814	3.080	259.7
35.00S	-4.094	15.593	2.254	259.5
40.00S	-6.101	17.598	1.321	259.3
50.00S	-10.064	22.693	-1.053	259.1

Note: Drafts are measured at A.P. and F.P along ship's centerline

GZ SUMMARY (Evaluated per IMO (SOLAS'90) Rules for Passenger Ships)

	Available	Required
Static Heel Angle	2.07S deg	7.00 deg
Freeboard to Downflooding	2.725 ft	
Angle at Maximum GZ	14.00S deg	
Maximum GZ	2.465 ft	1.380 ft
Range of Positive GZ	22.19 deg	15.00 deg
Righting Area (2.07-7.00)	33.188 ft-deg	2.820 ft-deg

RTRN011B: FUEL (P)/ENG RM
 198' CASINO BOAT

Managed Compartments:
 FUEL (P) ENG RM

	DISPLACEMENT LTons	DRAFT AFT ft	DRAFT FWD ft	TRIM ft	HEEL deg.	UPRIGHT GMT ft
INTACT	1,777.9	6.280	6.280	0.000	0.00	23.932
DAMAGED	2,011.3	8.184	5.629	2.556A	2.07P	17.445

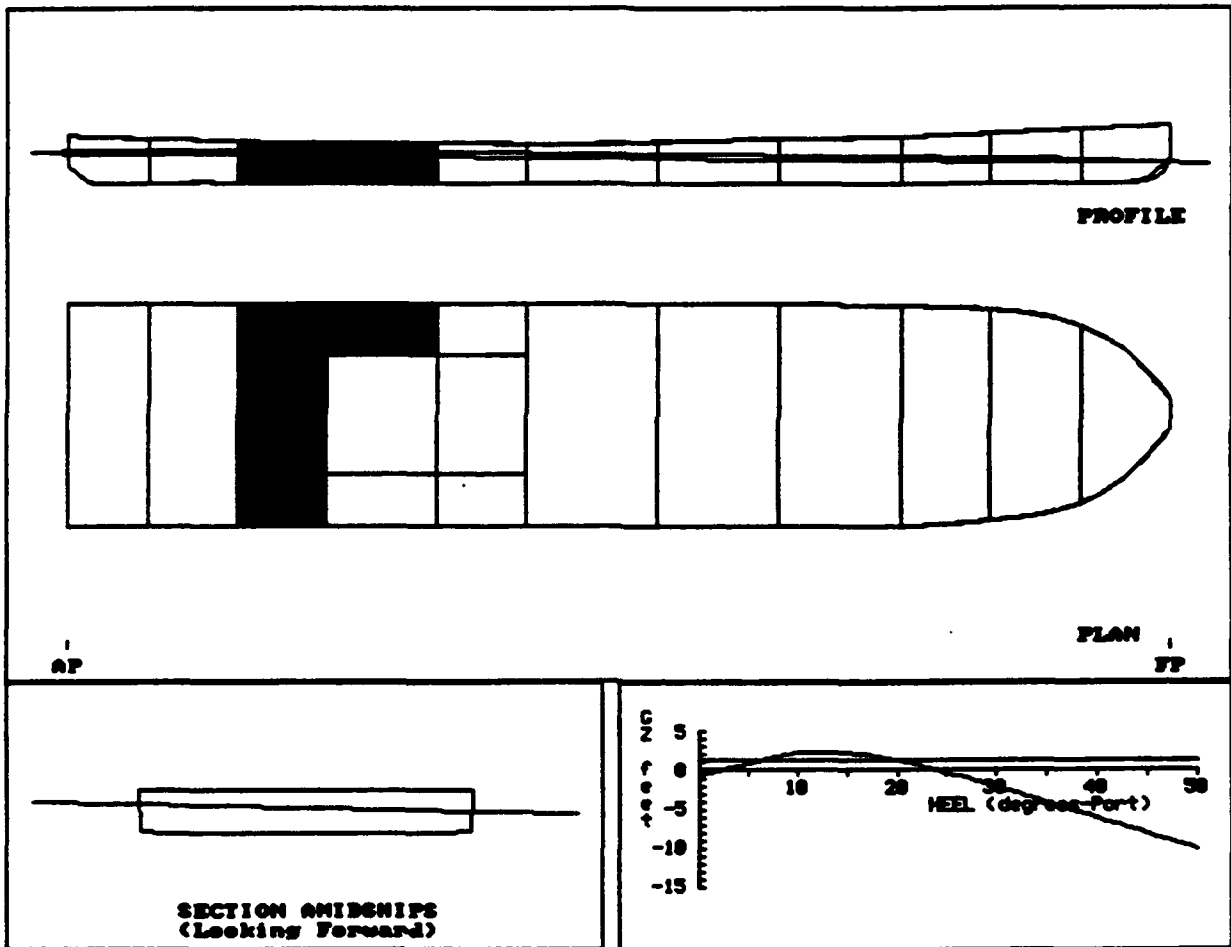

RTRN012B: ENG RM/MUFFLER
 198' CASINO BOAT

Imaged Compartments:
 ENG RM MUFFLER CMT

	DISPLACEMENT LTONS	DRAFT AFT ft	DRAFT FWD ft	TRIM ft	HEEL deg.	UPRIGHT GMT ft
INTACT	1,777.9	6.280	6.280	0.000	0.00	23.932
DAMAGED	2,192.5	10.208	4.473	5.735A	0.00	15.934

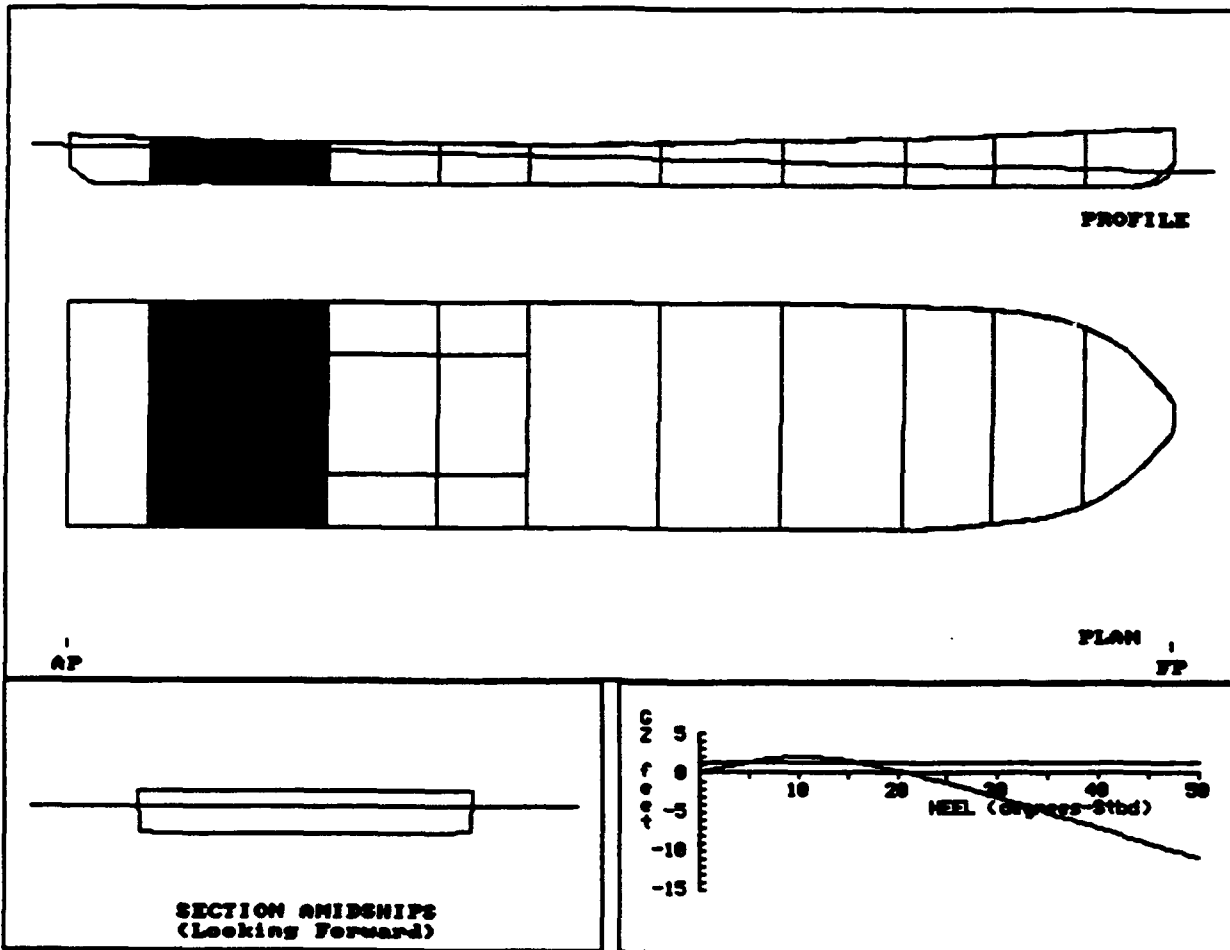

RTRM012B: ENG RM/MUFFLER
 198' CASINO BOAT

COMPARTMENT FLOODING SUMMARY

At 0.0o Heel	PERM.	FLOODED WTR LTons	% FULL (Damaged)	% FULL (Intact)	SP.VOL. ft3/LT	OUTFLOW LTons
ENG RM	0.85	211.0	FREE	0.0	----	----
MUFFLER CMPT	0.85	203.6	FREE	0.0	----	----
Totals		414.6				

INTACT DATA

Draft at AP = 6.280 ft	Kmt = 52.332 ft	LCG = 106.130A ft-FP
Draft at FP = 6.280 ft	VCG = 28.400 ft	LCB = 106.130A ft-FP
Displacement = 1777.9 LTons	Gmt = 23.932 ft	TCG = 0.000 ft-CL

DRAFT/GZ DATA

HEEL degrees	RIGHTING ARM ft	DRAFT AFT ft	DRAFT FWD ft	FLOODED WATER LTons
0.00	0.000	10.208	4.473	414.6
5.00S	1.385	10.244	4.421	414.7
10.00S	2.046	10.949	4.049	411.8
15.00S	1.608	12.621	3.279	416.0
20.00S	0.414	14.861	2.305	421.3
25.00S	-1.240	17.474	1.128	425.1
30.00S	-3.112	20.453	-0.274	428.0
35.00S	-5.073	23.844	-1.909	430.6
40.00S	-7.054	27.733	-3.805	433.0
50.00S	-10.910	37.671	-8.714	436.7

Note: Drafts are measured at A.P. and F.P along ship's centerline

GZ SUMMARY (Evaluated per IMO (SOLAS'90) Rules for Passenger Ships)
 Available Required

Static Heel Angle	0.00 deg	7.00 deg
Freeboard to Downflooding	2.275 ft	
Angle at Maximum GZ	11.00S deg	
Maximum GZ	2.046 ft	1.380 ft
Range of Positive GZ	21.35 deg	15.00 deg
Gmt (upright damaged)	15.934 ft	
Righting Area (0.00-3.35)	27.665 ft-deg	2.820 ft-deg

RTRM013B: MUFFLER/STEER
 198' CASINO BOAT

Imaged Compartments:
 MUFFLER CMT STEERING RM

	DISPLACEMENT LTons	DRAFT AFT ft	DRAFT FWD ft	TRIM ft	HEEL deg.	UPRIGHT GMT ft
INTACT	1,777.9	6.280	6.280	0.000	0.00	23.932
DAMAGED	2,095.5	9.736	4.358	5.378A	0.00	15.798

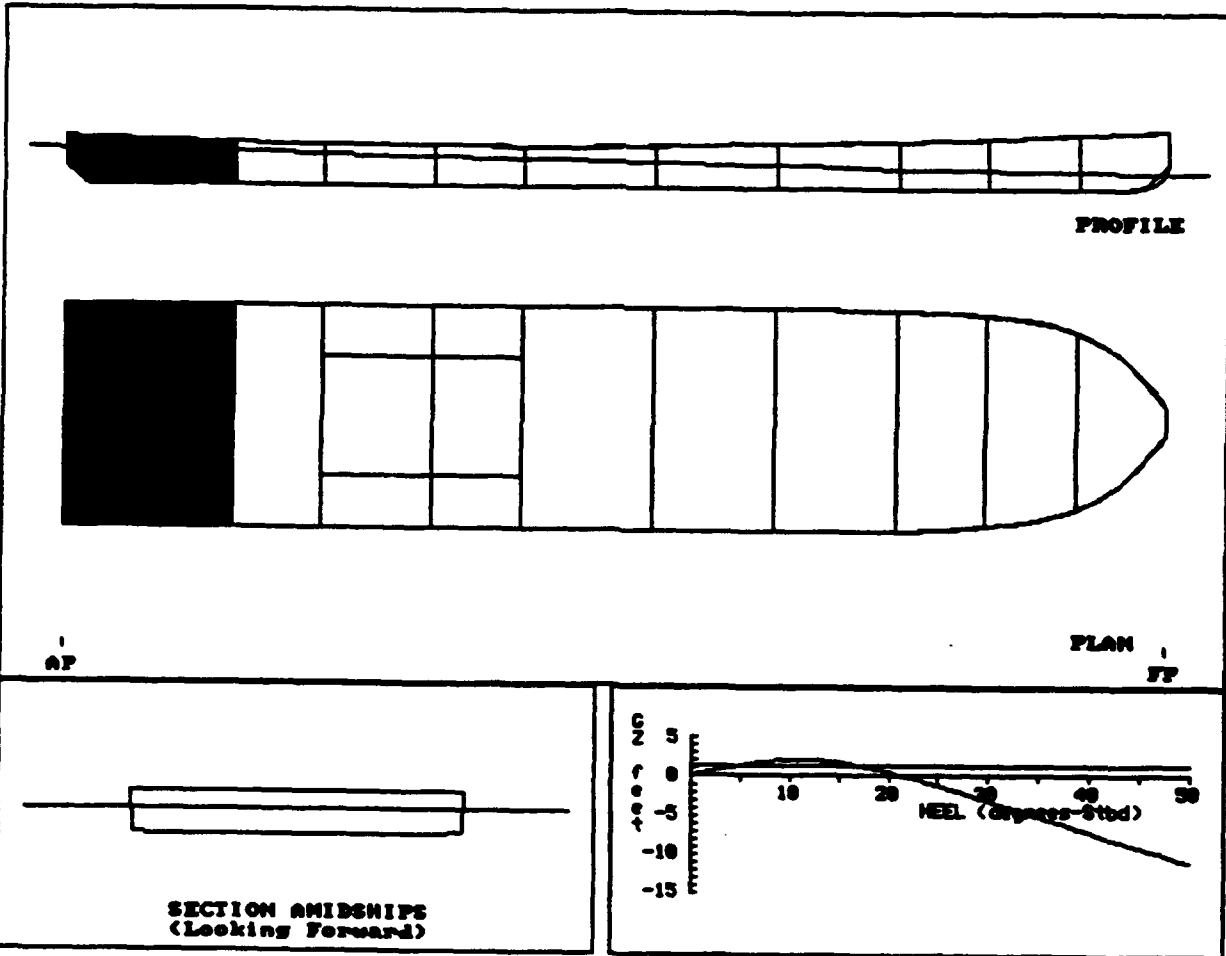

RTRN013B: MUFFLER/STEER
 198' CASINO BOAT

COMPARTMENT FLOODING SUMMARY

At 0.0o Heel	PERM.	FLOODED WTR LTons	% FULL (Damaged)	% FULL (Intact)	SP.VOL. ft3/LT	OUTFLOW LTons
MUFFLER CMPT	0.85	193.6	FREE	0.0	----	----
STEERING RM	0.85	124.0	FREE	0.0	----	----
Totals		317.6				

INTACT DATA

Draft at AP = 6.280 ft KMT = 52.332 ft LCG = 106.130A ft-FP
 Draft at FP = 6.280 ft VCG = 28.400 ft LCB = 106.130A ft-FP
 Displacement = 1777.9 LTons GMT = 23.932 ft TCG = 0.000 ft-CL

DRAFT/GZ DATA

HEEL degrees	RIGHTING ARM ft	DRAFT AFT ft	DRAFT FWD ft	FLOODED WATER LTons
0.00	0.000	9.736	4.358	317.6
5.00S	1.381	9.802	4.274	320.1
10.00S	2.137	10.481	3.869	328.1
15.00S	1.730	12.224	2.974	342.7
20.00S	0.507	14.593	1.805	356.7
25.00S	-1.194	17.391	0.367	368.1
30.00S	-3.118	20.616	-1.353	377.6
35.00S	-5.131	24.333	-3.405	385.7
40.00S	-7.156	28.583	-5.762	392.4
50.00S	-11.087	39.421	-11.821	402.5

Note: Drafts are measured at A.P. and F.P along ship's centerline

GZ SUMMARY (Evaluated per IMO (SOLAS'90) Rules for Passenger Ships)
 Available Required

Static Heel Angle	0.00 deg	7.00 deg
Freeboard to Downflooding	2.692 ft	
Angle at Maximum GZ	12.00S deg	
Maximum GZ	2.146 ft	1.380 ft
Range of Positive GZ	21.60 deg	15.00 deg
Gmt (upright damaged)	15.798 ft	
Righting Area (0.00-3.60)	29.081 ft-deg	2.820 ft-deg

RTRM014B: OFFICE/LOUNGE 2
 198' CASINO BOAT

Imaged Compartments:
 OFFICES LOUNGE/HEAD

	DISPLACEMENT LTons	DRAFT AFT ft	DRAFT FWD ft	TRIM ft	HEEL deg.	UPRIGHT GMT ft
INTACT	1,777.9	6.280	6.280	0.000	0.00	23.932
DAMAGED	2,409.4	5.848	11.109	5.261F	0.00	14.775

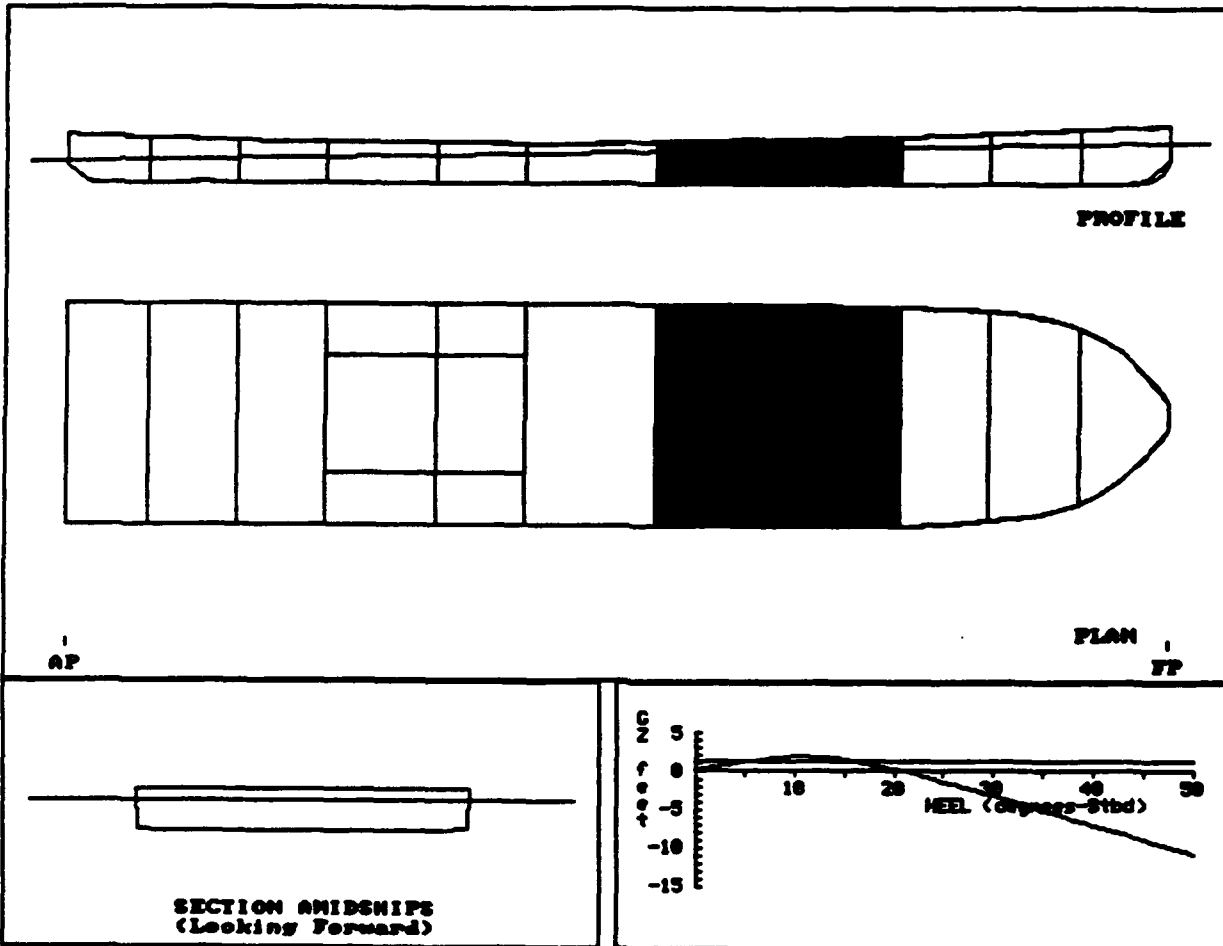

RTRN015B: AC MACHY/H2O
 198' CASINO BOAT

Damaged Compartments:
 A/C MACHY FRESH H2O

	DISPLACEMENT LTONS	DRAFT AFT ft	DRAFT FWD ft	TRIM ft	HEEL deg.	UPRIGHT GMT ft
INTACT	1,777.9	6.280	6.280	0.000	0.00	23.932
DAMAGED	1,969.8	7.414	6.267	1.147A	0.00	22.605

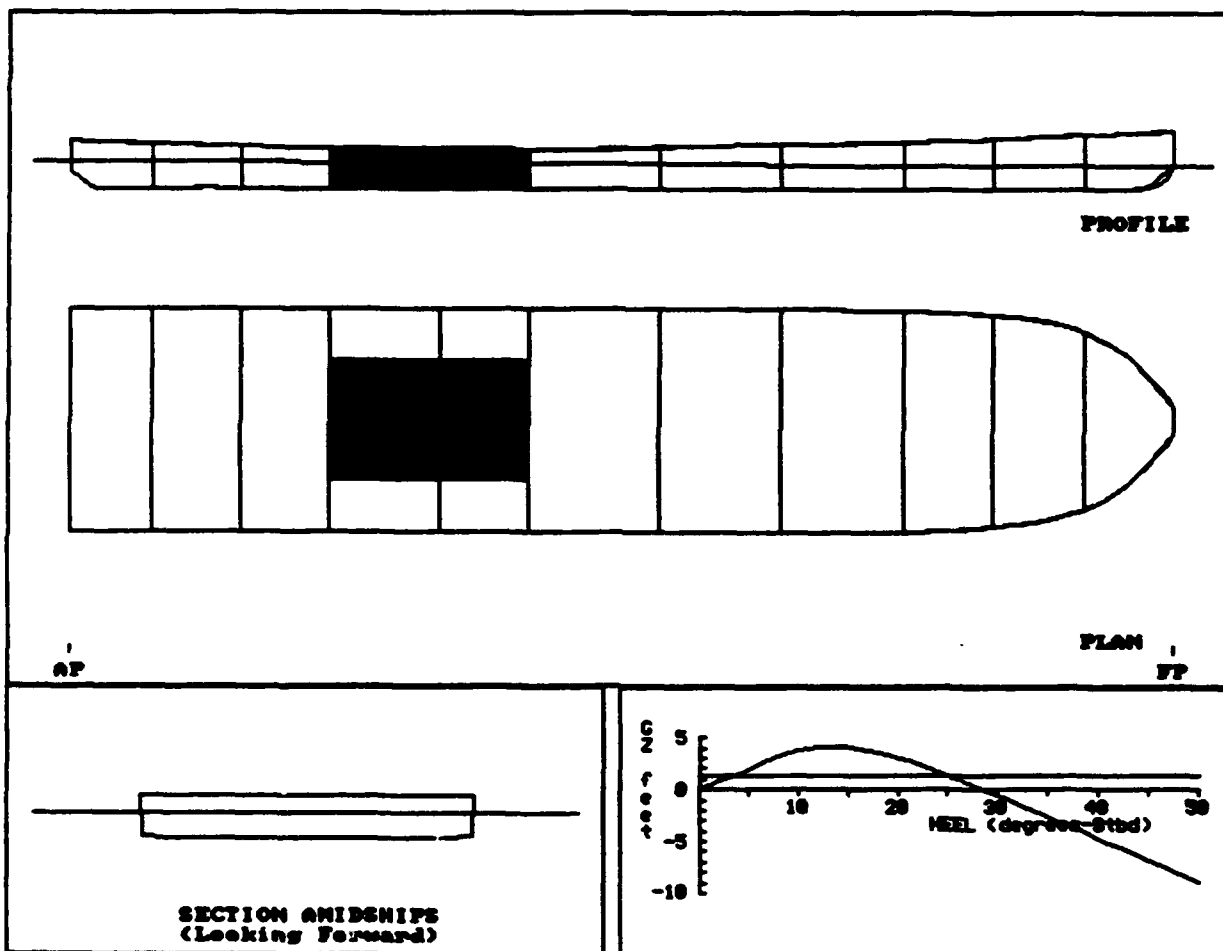

RTRN015B: AC MACHY/H2O
 198' CASINO BOAT

COMPARTMENT FLOODING SUMMARY

At 0.0o Heel	PERM.	FLOODED WTR LTons	‡ FULL (Damaged)	‡ FULL (Intact)	SP.VOL. ft3/LT	OUTFLOW LTons
A/C MACHY	0.85	109.8	FREE	0.0	----	----
FRESH H2O	0.95	96.7	FREE	10.0	35.8800	14.7
Totals		206.6				14.7

INTACT DATA

Draft at AP = 6.280 ft KMt = 52.332 ft LCG = 106.130A ft-FP
 Draft at FP = 6.280 ft VCG = 28.400 ft LCB = 106.130A ft-FP
 Displacement = 1777.9 LTons GMT = 23.932 ft TCG = 0.000 ft-CL

DRAFT/GZ DATA

HEEL degrees	RIGHTING ARM ft	DRAFT AFT ft	DRAFT FWD ft	FLOODED WATER LTons
0.00	0.000	7.414	6.267	206.6
5.00S	1.986	7.435	6.219	206.5
10.00S	3.802	7.511	6.122	207.1
15.00S	4.125	8.254	5.838	218.1
20.00S	3.074	9.237	5.489	225.1
25.00S	1.397	10.253	5.115	226.8
30.00S	-0.554	11.333	4.697	225.6
35.00S	-2.623	12.534	4.217	223.8
40.00S	-4.738	13.904	3.670	222.5
50.00S	-8.943	17.424	2.244	220.7

Note: Drafts are measured at A.P. and F.P along ship's centerline

GZ SUMMARY (Evaluated per IMO (SOLAS'90) Rules for Passenger Ships)
 Available Required

Static Heel Angle	0.00 deg	7.00 deg
Freeboard to Downflooding	4.363 ft	
Angle at Maximum GZ	14.00S deg	
Maximum GZ	4.197 ft	1.380 ft
Range of Positive GZ	28.62 deg	15.00 deg
Gmt (upright damaged)	22.605 ft	
Righting Area (0.00-‡.00)	64.153 ft-deg	2.820 ft-deg

RTRN016B: AC MACHY/ENG RM
 198' CASINO BOAT

amaged Compartments:
 A/C MACHY ENG RM

	DISPLACEMENT LTons	DRAFT AFT ft	DRAFT FWD ft	TRIM ft	HEEL deg.	UPRIGHT GMT ft
INTACT	1,777.9	6.280	6.280	0.000	0.00	23.932
DAMAGED	2,086.4	8.705	5.539	3.166A	0.00	19.222

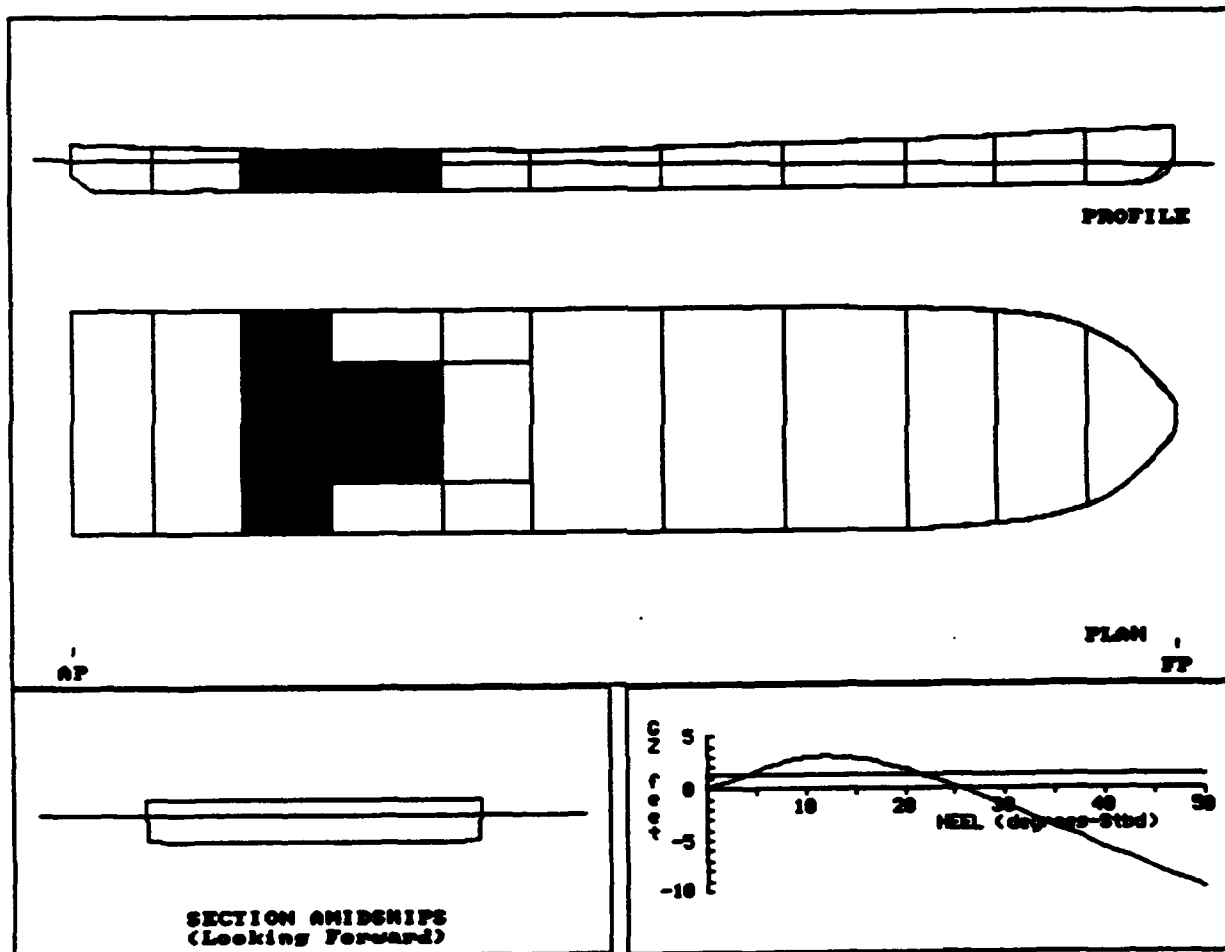

RTRN016B: AC MACHY/ENG RM
 198' CASINO BOAT

COMPARTMENT FLOODING SUMMARY

At 0.0o Heel	PERM.	FLOODED WTR LTons	% FULL (Damaged)	% FULL (Intact)	SP.VOL. ft3/LT	OUTFLOW LTons
A/C MACHY	0.85	121.0	FREE	0.0	----	----
ENG RM	0.85	187.5	FREE	0.0	----	----
Totals		308.5				

INTACT DATA

Draft at AP = 6.280 ft KMT = 52.332 ft LCG = 106.130A ft-FP
 Draft at FP = 6.280 ft VCG = 28.400 ft LCB = 106.130A ft-FP
 Displacement = 1777.9 LTons GMT = 23.932 ft TCG = 0.000 ft-CL

DRAFT/GZ DATA

HEEL degrees	RIGHTING ARM ft	DRAFT AFT ft	DRAFT FWD ft	FLOODED WATER LTons
0.00	0.000	8.705	5.539	308.5
5.00S	1.690	8.738	5.479	309.0
10.00S	2.994	9.038	5.294	309.7
15.00S	2.905	10.215	4.808	317.5
20.00S	1.831	11.886	4.155	323.6
25.00S	0.209	13.747	3.417	327.4
30.00S	-1.678	15.794	2.572	329.9
35.00S	-3.671	18.054	1.635	331.4
40.00S	-5.700	20.636	0.533	332.4
50.00S	-9.713	27.108	-2.268	332.7

Note: Drafts are measured at A.P. and F.P along ship's centerline

GZ SUMMARY (Evaluated per IMO (SOLAS'90) Rules for Passenger Ships)

	Available	Required
Static Heel Angle	0.00 deg	7.00 deg
Freeboard to Downflooding	3.383 ft	
Angle at Maximum GZ	13.00S deg	
Maximum GZ	3.125 ft	1.380 ft
Range of Positive GZ	25.58 deg	15.00 deg
Gmt (upright damaged)	19.222 ft	
Righting Area (0.00-3.00)	46.830 ft-deg	2.820 ft-deg

RTRN017B: AC MACHY/FUEL
 198' CASINO BOAT

Damaged Compartments:
 FUEL A/C MACHY

	DISPLACEMENT LTons	DRAFT AFT ft	DRAFT FWD ft	TRIM ft	HEEL deg.	UPRIGHT GMT ft
INTACT	1,777.9	6.280	6.280	0.000	0.00	23.932
DAMAGED	1,936.7	7.352	6.107	1.245A	1.64S	20.641

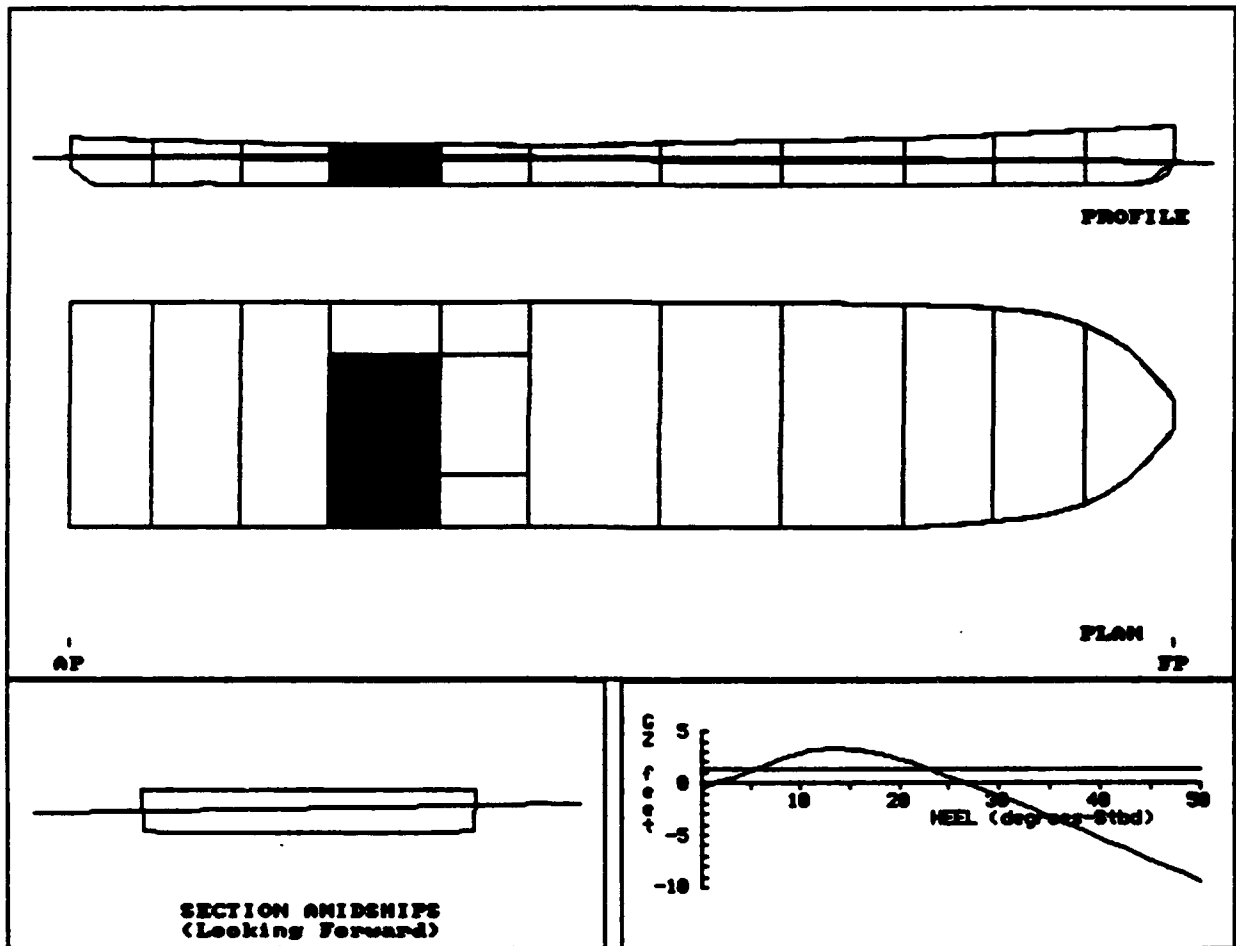

RTRN017B: AC MACHY/FUEL
 198' CASINO BOAT

COMPARTMENT FLOODING SUMMARY

At 1.6oS Heel	PERM.	FLOODED WTR LTons	% FULL (Damaged)	% FULL (Intact)	SP.VOL. ft3/LT	OUTFLOW LTons
FUEL	0.95	58.0	FREE	10.0	38.5800	7.6
A/C MACHY	0.85	108.4	FREE	0.0	----	----
Totals		166.4				7.6

INTACT DATA

Draft at AP = 6.280 ft	KMt = 52.332 ft	LCG = 106.130A ft-FP
Draft at FP = 6.280 ft	VCG = 28.400 ft	LCB = 106.130A ft-FP
Displacement = 1777.9 LTons	GMT = 23.932 ft	TCG = 0.000 ft-CL

DRAFT/GZ DATA

HEEL degrees	RIGHTING ARM ft	DRAFT AFT ft	DRAFT FWD ft	FLOODED WATER LTons
0.00	-0.587	7.309	6.122	160.8
5.00S	1.230	7.429	6.075	177.8
10.00S	2.917	7.612	5.955	192.9
15.00S	3.270	8.388	5.609	201.5
20.00S	2.283	9.382	5.205	205.7
25.00S	0.662	10.427	4.769	207.1
30.00S	-1.232	11.562	4.285	207.1
35.00S	-3.245	12.833	3.726	206.5
40.00S	-5.304	14.283	3.088	206.0
50.00S	-9.392	18.008	1.425	205.4

Note: Drafts are measured at A.P. and F.P along ship's centerline

GZ SUMMARY (Evaluated per IMO (SOLAS'90) Rules for Passenger Ships)
 Available Required

Static Heel Angle	1.64S deg	7.00 deg
Freeboard to Downflooding	3.583 ft	
Angle at Maximum GZ	15.00S deg	
Maximum GZ	3.323 ft	1.380 ft
Range of Positive GZ	25.17 deg	15.00 deg
Righting Area (1.64-1.00)	47.064 ft-deg	2.820 ft-deg

RTRN018B: AC/FUEL/ER
 198' CASINO BOAT

Imaged Compartments:

A/C MACHY FUEL (P) ENG RM

	DISPLACEMENT LTons	DRAFT AFT ft	DRAFT FWD ft	TRIM ft	HEEL deg.	UPRIGHT GMT ft
INTACT	1,777.9	6.280	6.280	0.000	0.00	23.932
DAMAGED	2,162.6	9.226	5.431	3.795A	2.30P	16.952

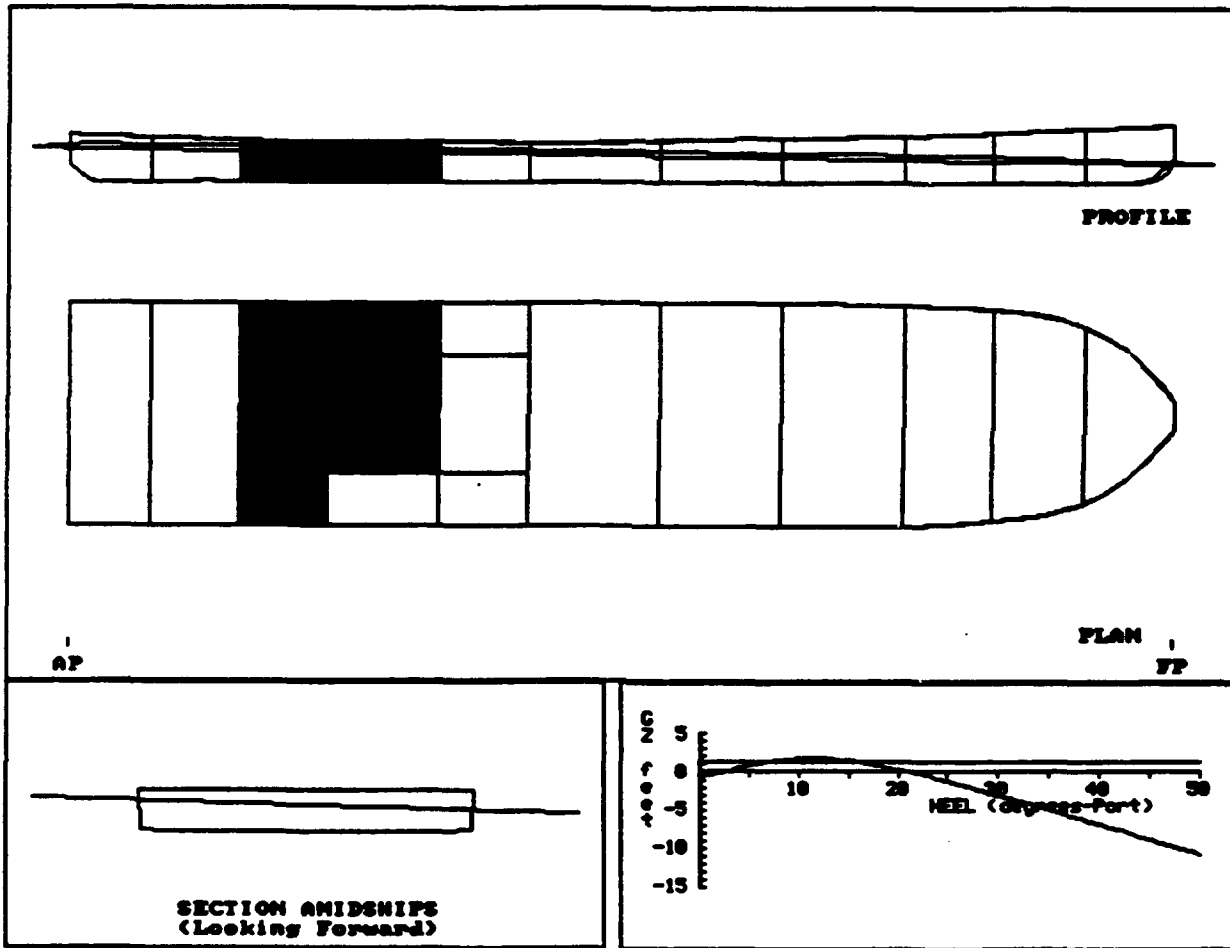

RTRN018B: AC/FUEL/ER
 198' CASINO BOAT

COMPARTMENT FLOODING SUMMARY

At 2.30P Heel	PERM.	FLOODED WTR LTons	% FULL (Damaged)	% FULL (Intact)	SP.VOL. ft3/LT	OUTFLOW LTons
A/C MACHY	0.85	126.4	FREE	0.0	----	----
FUEL (P)	0.95	68.8	FREE	10.0	38.5800	7.6
ENG RM	0.85	197.1	FREE	0.0	----	----
Totals		392.3				7.6

INTACT DATA

Draft at AP = 6.280 ft	KMT = 52.332 ft	LCG = 106.130A ft-FP
Draft at FP = 6.280 ft	VCG = 28.400 ft	LCB = 106.130A ft-FP
Displacement = 1777.9 LTons	GMT = 23.932 ft	TCG = 0.000 ft-CL

DRAFT/GZ DATA

HEEL degrees	RIGHTING ARM ft	DRAFT AFT ft	DRAFT FWD ft	FLOODED WATER LTons
0.00	-0.699	9.170	5.451	383.1
5.00P	0.796	9.322	5.387	403.1
10.00P	1.776	9.909	5.102	414.2
15.00P	1.525	11.333	4.557	422.1
20.00P	0.419	13.299	3.851	429.0
25.00P	-1.182	15.577	3.014	433.6
30.00P	-3.012	18.112	2.073	437.1
35.00P	-4.949	20.988	0.963	440.0
40.00P	-6.912	24.222	-0.298	442.1
50.00P	-10.754	32.365	-3.487	444.8

Note: Drafts are measured at A.P. and F.P along ship's centerline

GZ SUMMARY (Evaluated per IMO (SOLAS'90) Rules for Passenger Ships)

	Available	Required
Static Heel Angle	2.30P deg	7.00 deg
Freeboard to Downflooding	4.163 ft	
Angle at Maximum GZ	12.00P deg	
Maximum GZ	1.825 ft	1.380 ft
Range of Positive GZ	19.12 deg	15.00 deg
Righting Area (2.30-4.42)	22.050 ft-deg	2.820 ft-deg

**APPENDIX B
HYDROSTATICS AND
DAMAGE STABILITY
OUTPUT**

228' CASINO BOAT

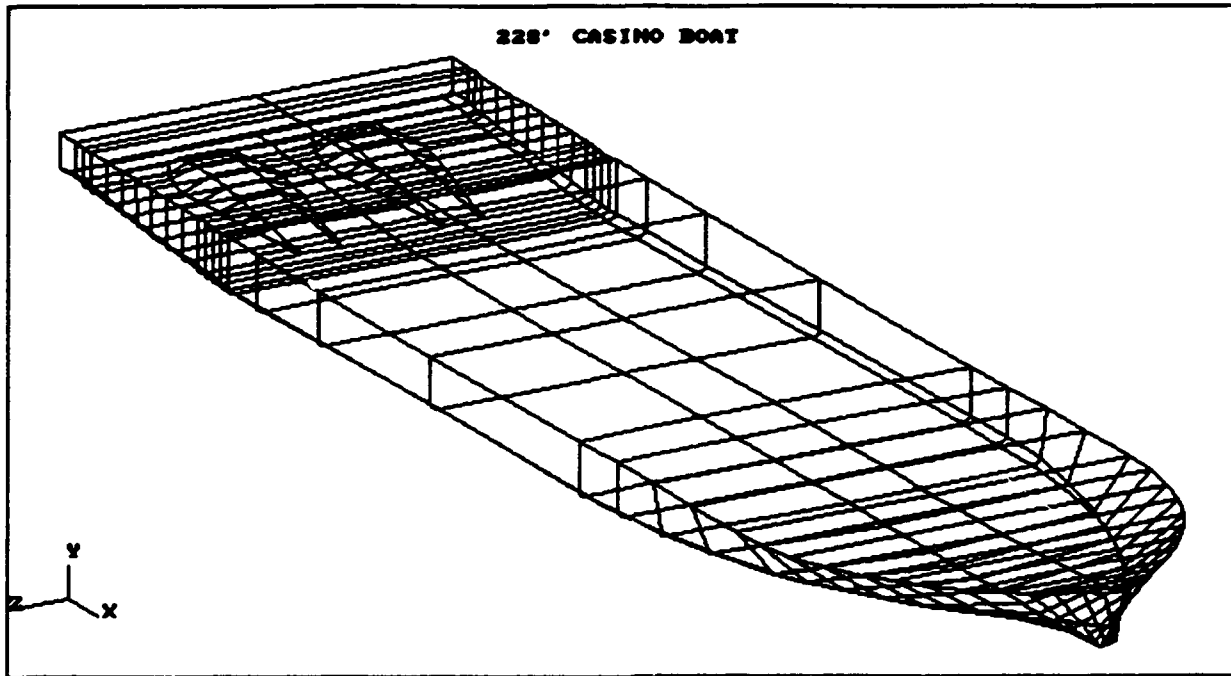

DAMAGE STABILITY SUMMARY

CASE No.	FILE NAME	DAMAGED COMP. LISTING	---Intact Condition---			-----Equilibrium Condition After Damage-----					SURVIVAL
			MN.DRAFT (ft)	VCG (ft)	GMt (ft)	HEEL (deg)	MAX.GZ (ft)	RANGE (deg)	AREA (ft-deg)	DAM.GMt (ft)	
1	RTRN001B	1,2	7.680	22.500	23.692	0.0	4.608	35.72	99.40	22.860	Yes
2	RTRN002B	2,3	7.680	22.500	23.692	0.0	3.332	30.83	64.14	20.185	Yes
3	RTRN003B	3,4	7.680	22.500	23.692	0.0	2.574	27.61	45.28	18.347	Yes
4	RTRN004B	4,5	7.680	22.500	23.692	0.0	2.421	27.27	42.24	18.268	Yes
5	RTRN005B	5,6	7.680	22.500	23.692	0.0	2.988	30.28	56.70	17.950	Yes
6	RTRN006B	5,6,7	7.680	22.500	23.692	0.0	2.779	29.02	50.83	17.941	Yes
7	RTRN007B	5,6,7	7.680	22.500	23.692	0.0	2.779	29.02	50.83	17.941	Yes
8	RTRN008B	6,7,8	7.680	22.500	23.692	0.0	3.574	32.62	71.80	18.892	Yes
9	RTRN009B	6,8,11	7.680	22.500	23.692	0.0	3.961	33.31	80.14	19.647	Yes
10	RTRN010B	6,7,8,11	7.680	22.500	23.692	0.0	3.793	32.50	75.41	19.568	Yes
11	RTRN011B	6,7,8,11,10	7.680	22.500	23.692	0.4P	3.526	31.27	67.85	----	Yes
12	RTRN012B	6,8,11,10	7.680	22.500	23.692	0.4P	3.697	32.15	72.66	----	Yes
13	RTRN013B	6,8,10,7	7.680	22.500	23.692	0.4P	3.319	31.37	64.49	----	Yes
14	RTRN014B	6,8,10	7.680	22.500	23.692	0.4P	3.486	32.30	69.37	----	Yes
15	RTRN015B	8,12	7.680	22.500	23.692	0.0	3.589	32.76	72.15	18.541	Yes
16	RTRN016B	8,12,10	7.680	22.500	23.692	0.4P	3.333	31.51	64.81	----	Yes
17	RTRN017B	8,12,10,11	7.680	22.500	23.692	0.4P	3.545	31.43	68.28	----	Yes
18	RTRN018B	8,12,11	7.680	22.500	23.692	0.0	3.813	32.66	75.88	19.203	Yes
19	RTRN019B	12,13	7.680	22.500	23.692	0.0	2.970	29.96	54.85	17.060	Yes
20	RTRN020B	13,14	7.680	22.500	23.692	0.0	2.226	26.11	36.69	15.891	Yes
21	RTRN021B	14,15	7.680	22.500	23.692	0.0	2.044	25.07	32.69	15.783	Yes
22	RTRN022B	16,15	7.680	22.500	23.692	0.0	2.518	27.39	42.91	15.688	Yes

DAMAGE STABILITY SUMMARY

CASE No.	FILE NAME	DAMAGED COMP. LISTING	---Intact Condition---			-----Equilibrium Condition After Damage-----					
			MM.DRAFT (ft)	VCG (ft)	GMt (ft)	HEEL (deg)	MAX.GZ (ft)	RANGE (deg)	AREA (ft-deg)	DAM.GMt (ft)	SURVIVAL
1	DPRT001A	1,2	7.850	22.500	22.802	0.0	4.301	34.67	90.61	22.038	Yes
2	DPRT002A	2,3	7.850	22.500	22.802	0.0	3.028	29.48	56.14	19.591	Yes
3	DPRT003A	3,4	7.850	22.500	22.802	0.0	2.282	25.97	37.94	17.866	Yes
4	DPRT004A	4,5	7.850	22.500	22.802	0.0	2.140	25.62	35.26	17.653	Yes
5	DPRT005A	5,6	7.850	22.500	22.802	0.0	2.726	28.99	49.71	17.279	Yes
6	DPRT006A	5,6,7	7.850	22.500	22.802	0.0	2.858	28.99	51.90	17.677	Yes
7	DPRT007A	5,6,7	7.850	22.500	22.802	0.0	2.858	28.99	51.90	17.677	Yes
8	DPRT008A	6,7,8	7.850	22.500	22.802	0.0	3.617	32.28	71.58	18.688	Yes
9	DPRT009A	6,8,11	7.850	22.500	22.802	0.0	3.232	31.23	62.60	18.107	Yes
10	DPRT010A	6,7,8,11	7.850	22.500	22.802	0.0	3.391	31.18	65.21	18.552	Yes
11	DPRT011A	6,7,8,11,10	7.850	22.500	22.802	0.2S	3.266	30.47	61.48	----	Yes
12	DPRT012A	6,8,11,10	7.850	22.500	22.802	0.2S	3.116	30.55	59.12	----	Yes
13	DPRT013A	6,8,10,7	7.850	22.500	22.802	0.3S	3.479	31.53	67.40	----	Yes
14	DPRT014A	6,8,10	7.850	22.500	22.802	0.2S	3.327	31.66	65.08	----	Yes
15	DPRT015A	8,12	7.850	22.500	22.802	0.0	3.300	31.57	64.24	17.823	Yes
16	DPRT016A	8,12,10	7.850	22.500	22.802	0.2S	3.181	30.87	60.66	----	Yes
17	DPRT017A	8,12,10,11	7.850	22.500	22.802	0.2S	2.959	29.59	54.03	----	Yes
18	DPRT018A	8,12,11	7.850	22.500	22.802	0.0	3.065	30.24	57.15	17.698	Yes
19	DPRT019A	12,13	7.850	22.500	22.802	0.0	2.692	28.50	47.24	16.389	Yes
20	DPRT020A	13,14	7.850	22.500	22.802	0.0	1.952	24.26	29.93	15.250	Yes
21	DPRT021A	14,15	7.850	22.500	22.802	0.0	1.755	23.18	26.11	15.132	Yes
22	DPRT022A	16,15	7.850	22.500	22.802	0.0	2.206	25.72	35.70	15.006	Yes

DPRT001A: FPK/VOID1
 228' CASINO BOAT

Imaged Compartments:
 FOREPEAK THRUST/VOID

	DISPLACEMENT LTons	DRAFT AFT ft	DRAFT FWD ft	TRIM ft	HEEL deg.	UPRIGHT GMT ft
INTACT	2,408.5	7.850	7.850	0.000	0.00	22.802
DAMAGED	2,553.5	7.050	9.685	2.635F	0.00	22.038

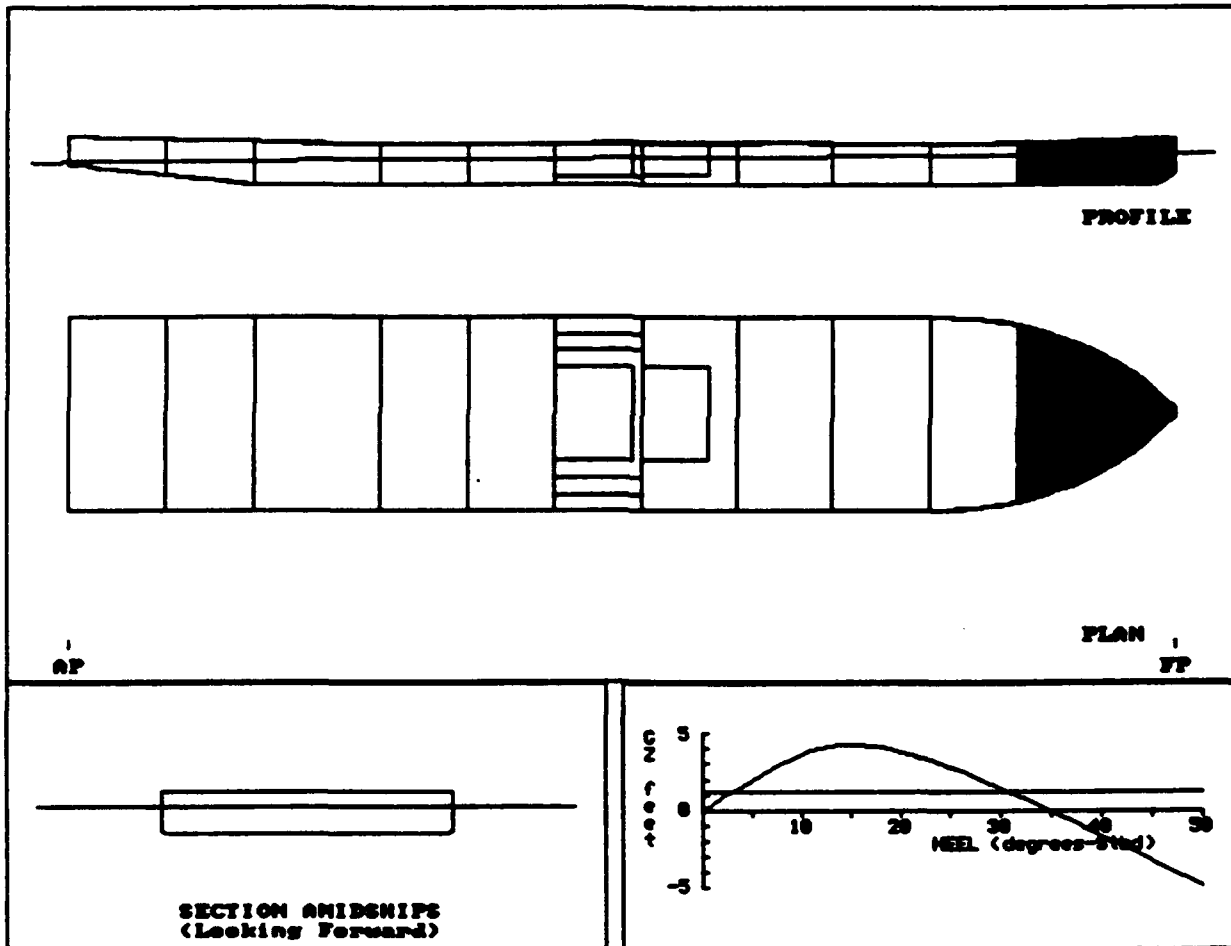

DPR001A: FPK/VOID1
 228' CASINO BOAT

COMPARTMENT FLOODING SUMMARY

At 0.0o Heel	PERM.	FLOODED WTR LTons	% FULL (Damaged)	% FULL (Intact)	SP.VOL. ft3/LT	OUTFLOW LTons
FOREPEAK	0.95	28.4	FREE	0.0	----	----
THRUST/VOID	0.95	116.6	FREE	0.0	----	----
Totals		145.0				

INTACT DATA

Draft at AP = 7.850 ft Kmt = 45.302 ft LCG = 120.717A ft-FP
 Draft at FP = 7.850 ft VCG = 22.500 ft LCB = 120.717A ft-FP
 Displacement = 2408.5 LTons Gmt = 22.802 ft TCG = 0.000 ft-CL

DRAFT/GZ DATA

HEEL degrees	RIGHTING ARM ft	DRAFT AFT ft	DRAFT FWD ft	FLOODED WATER LTons
0.00	0.000	7.050	9.685	145.0
5.00S	1.904	7.019	9.678	146.3
7.00S	2.654	6.974	9.682	147.9
10.00S	3.652	6.828	9.812	153.4
15.00S	4.301	6.421	10.815	173.5
20.00S	3.861	5.928	12.407	192.8
25.00S	2.775	5.343	14.249	206.4
30.00S	1.405	4.678	16.303	215.4
35.00S	-0.101	3.914	18.625	221.8
40.00S	-1.671	3.031	21.277	226.5
50.00S	-4.864	0.752	28.089	233.1

Note: Drafts are measured at A.P. and F.P along ship's centerline

GZ SUMMARY (Evaluated per IMO (SOLAS'90) Rules for Passenger Ships)

	Available	Required
Static Heel Angle	0.00 deg	7.00 deg
Angle at Maximum GZ	16.00S deg	
Maximum GZ	4.301 ft	1.160 ft
Range of Positive GZ	34.67 deg	15.00 deg
Gmt (upright damaged)	22.038 ft	
Righting Area (0.00-7.00)	67.369 ft-deg	2.820 ft-deg

DPRT002A: THRUST/TRANS
 228' CASINO BOAT

Imaged Compartments:

THRUST/VOID TRANSFORMERS

	DISPLACEMENT LTons	DRAFT AFT ft	DRAFT FWD ft	TRIM ft	HEEL deg.	UPRIGHT Gmt ft
INTACT	2,408.5	7.850	7.850	0.000	0.00	22.802
DAMAGED	2,810.8	6.088	12.323	6.235F	0.00	19.591

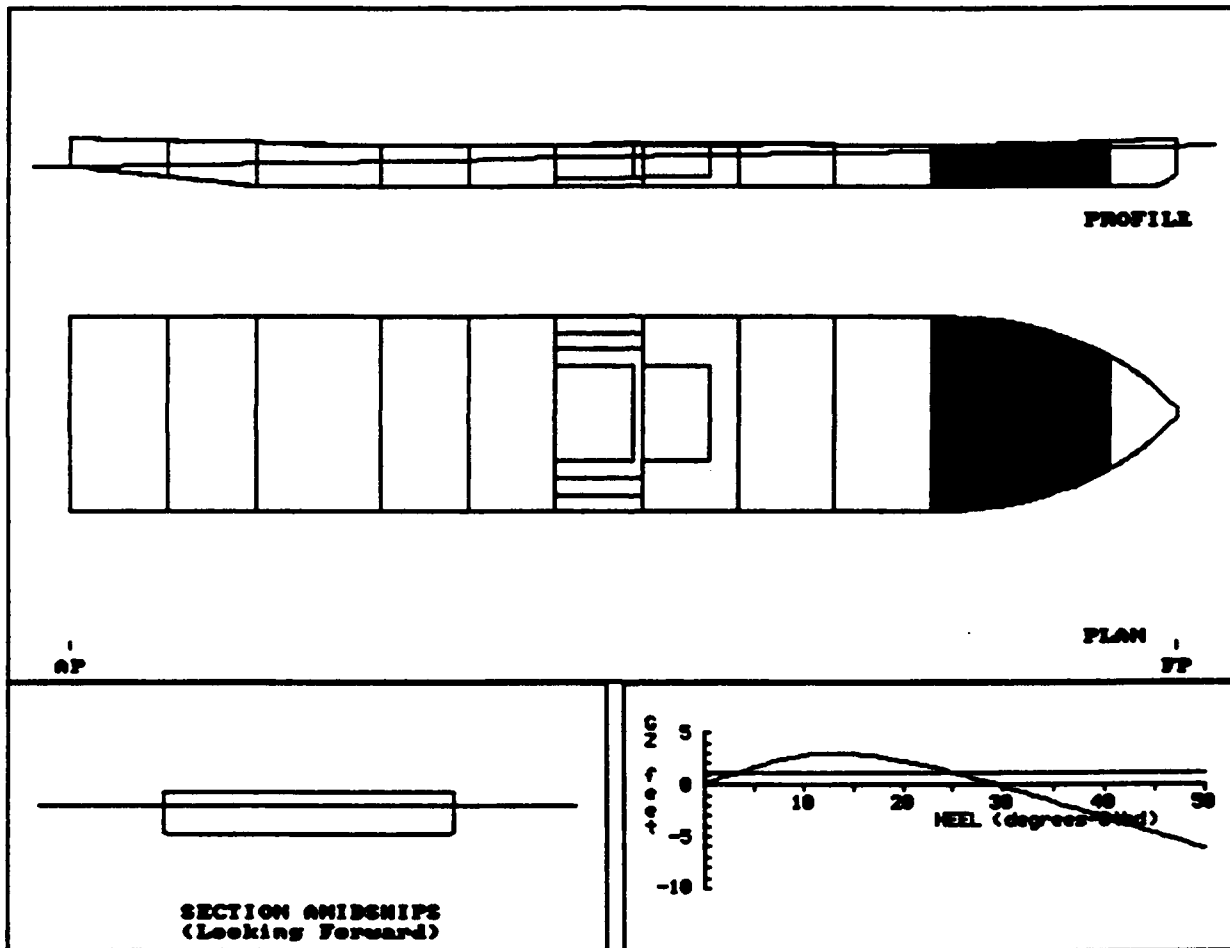

DPRT002A: THRUST/TRANS
 228' CASINO BOAT

COMPARTMENT FLOODING SUMMARY

At 0.0o Heel	PERM.	FLOODED WTR LTons	% FULL (Damaged)	% FULL (Intact)	SP.VOL. ft3/LT	OUTFLOW LTons
THRUST/VOID	0.95	162.0	FREE	0.0	----	----
TRANSFORMERS	0.95	240.3	FREE	0.0	----	----
Totals		402.3				

INTACT DATA

Draft at AP = 7.850 ft Kmt = 45.302 ft LCG = 120.717A ft-FP
 Draft at FP = 7.850 ft VCG = 22.500 ft LCB = 120.717A ft-FP
 Displacement = 2408.5 LTons Gmt = 22.802 ft TCG = 0.000 ft-CL

DRAFT/GZ DATA

HEEL degrees	RIGHTING ARM ft	DRAFT AFT ft	DRAFT FWD ft	FLOODED WATER LTons
0.00	0.000	6.088	12.323	402.3
5.00S	1.676	5.981	12.399	405.8
7.00S	2.245	5.863	12.556	405.6
10.00S	2.819	5.550	13.147	408.8
15.00S	2.983	4.866	14.962	421.2
20.00S	2.346	3.865	17.751	437.2
25.00S	1.214	2.633	21.149	450.2
30.00S	-0.150	1.186	25.093	460.1
35.00S	-1.621	-0.470	29.581	467.2
40.00S	-3.142	-2.474	34.833	472.7
50.00S	-6.165	-7.631	48.256	479.9

Note: Drafts are measured at A.P. and F.P along ship's centerline

GZ SUMMARY (Evaluated per IMO (SOLAS'90) Rules for Passenger Ships)

	Available	Required
Static Heel Angle	0.00 deg	7.00 deg
Angle at Maximum GZ	14.00S deg	
Maximum GZ	3.029 ft	1.160 ft
Range of Positive GZ	29.47 deg	15.00 deg
Gmt (upright damaged)	19.591 ft	
Righting Area (0.00-7.00)	48.627 ft-deg	2.820 ft-deg

DPR003A: TRANS/PUMP RM1
 228' CASINO BOAT

Seaged Compartments:
 TRANSFORMERS PUMP RM 1

	DISPLACEMENT LTons	DRAFT AFT ft	DRAFT FWD ft	TRIM ft	HEEL deg.	UPRIGHT GMT ft
INTACT	2,408.5	7.850	7.850	0.000	0.00	22.802
DAMAGED	3,013.3	6.081	13.514	7.433F	0.00	17.866

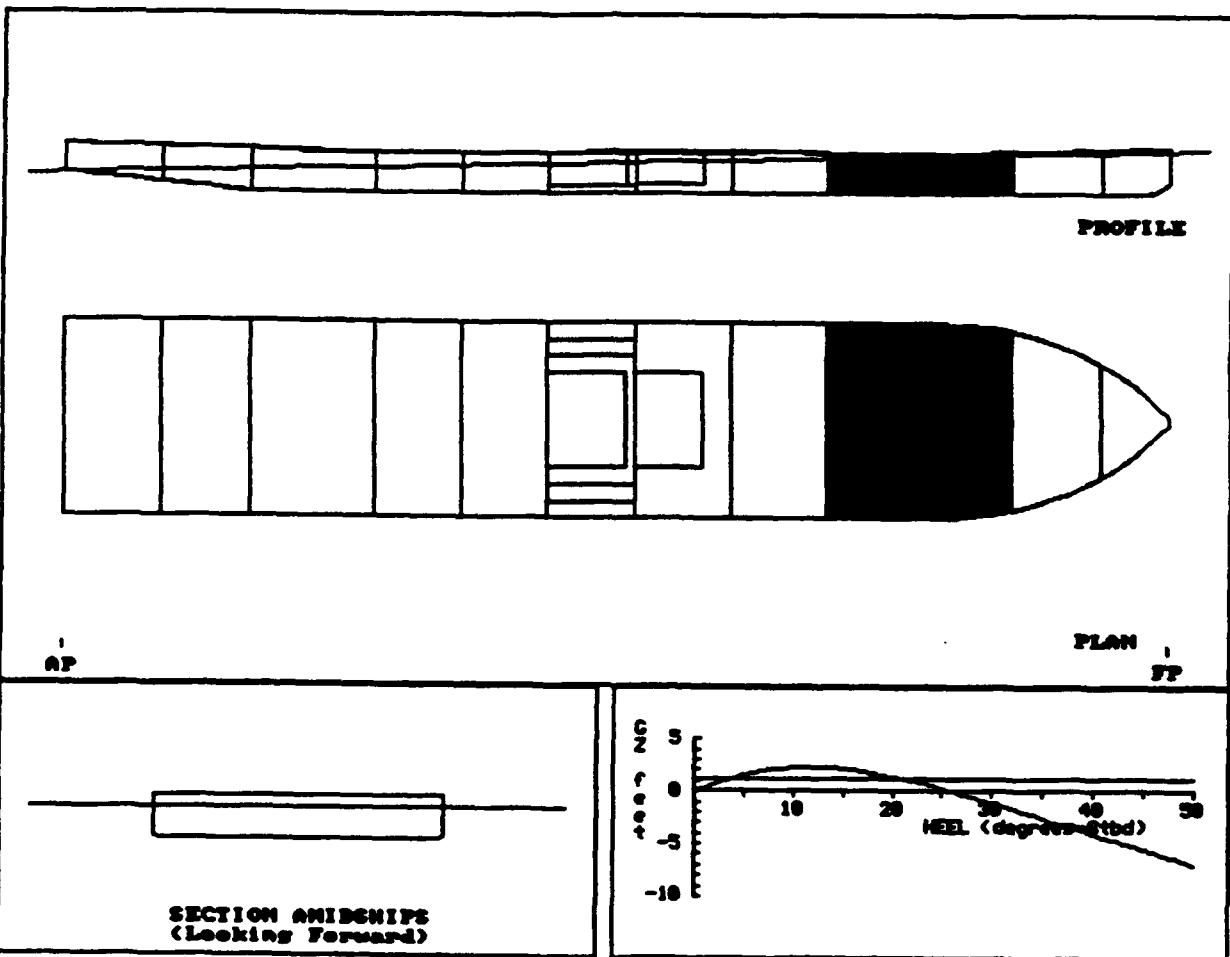

DPRT003A: TRANS/PUMP RM1
 228' CASINO BOAT

COMPARTMENT FLOODING SUMMARY

At 0.0o Heel	PERM.	FLOODED WTR LTons	% FULL (Damaged)	% FULL (Intact)	SP.VOL. ft3/LT	OUTFLOW LTons
TRANSFORMERS	0.95	267.3	FREE	0.0	----	----
PUMP RM 1	0.95	337.5	FREE	0.0	----	----
Totals		604.8				

INTACT DATA

Draft at AP = 7.850 ft Kmt = 45.302 ft LCG = 120.717A ft-FP
 Draft at FP = 7.850 ft VCG = 22.500 ft LCB = 120.717A ft-FP
 Displacement = 2408.5 LTons GMT = 22.802 ft TCG = 0.000 ft-CL

DRAFT/GZ DATA

HEEL degrees	RIGHTING ARM ft	DRAFT AFT ft	DRAFT FWD ft	FLOODED WATER LTons
0.00	0.000	6.081	13.514	604.8
5.00S	1.453	5.955	13.677	597.9
7.00S	1.880	5.796	13.980	592.9
10.00S	2.229	5.428	14.843	591.1
15.00S	2.130	4.652	17.180	598.1
20.00S	1.394	3.598	20.544	611.0
25.00S	0.254	2.295	24.694	623.9
30.00S	-1.113	0.634	29.718	635.9
35.00S	-2.562	-1.308	35.563	645.7
40.00S	-4.051	-3.729	42.581	654.0
50.00S	-6.944	-9.884	60.380	663.8

Note: Drafts are measured at A.P. and F.P along ship's centerline

GZ SUMMARY (Evaluated per IMO (SOLAS'90) Rules for Passenger Ships)

	Available	Required
Static Heel Angle	0.00 deg	7.00 deg
Angle at Maximum GZ	13.00S deg	
Maximum GZ	2.282 ft	1.160 ft
Range of Positive GZ	25.97 deg	15.00 deg
Gmt (upright damaged)	17.866 ft	
Righting Area (0.00-7.00)	35.951 ft-deg	2.820 ft-deg

DPRT004A: PUMP RMS 1,2
 228' CASINO BOAT

Imaged Compartments:
 PUMP RM 1 PUMP RM 2

	DISPLACEMENT LTons	DRAFT AFT ft	DRAFT FWD ft	TRIM ft	HEEL deg.	UPRIGHT GMT ft
INTACT	2,408.5	7.850	7.850	0.000	0.00	22.802
DAMAGED	3,089.7	6.880	13.065	6.185F	0.00	17.653

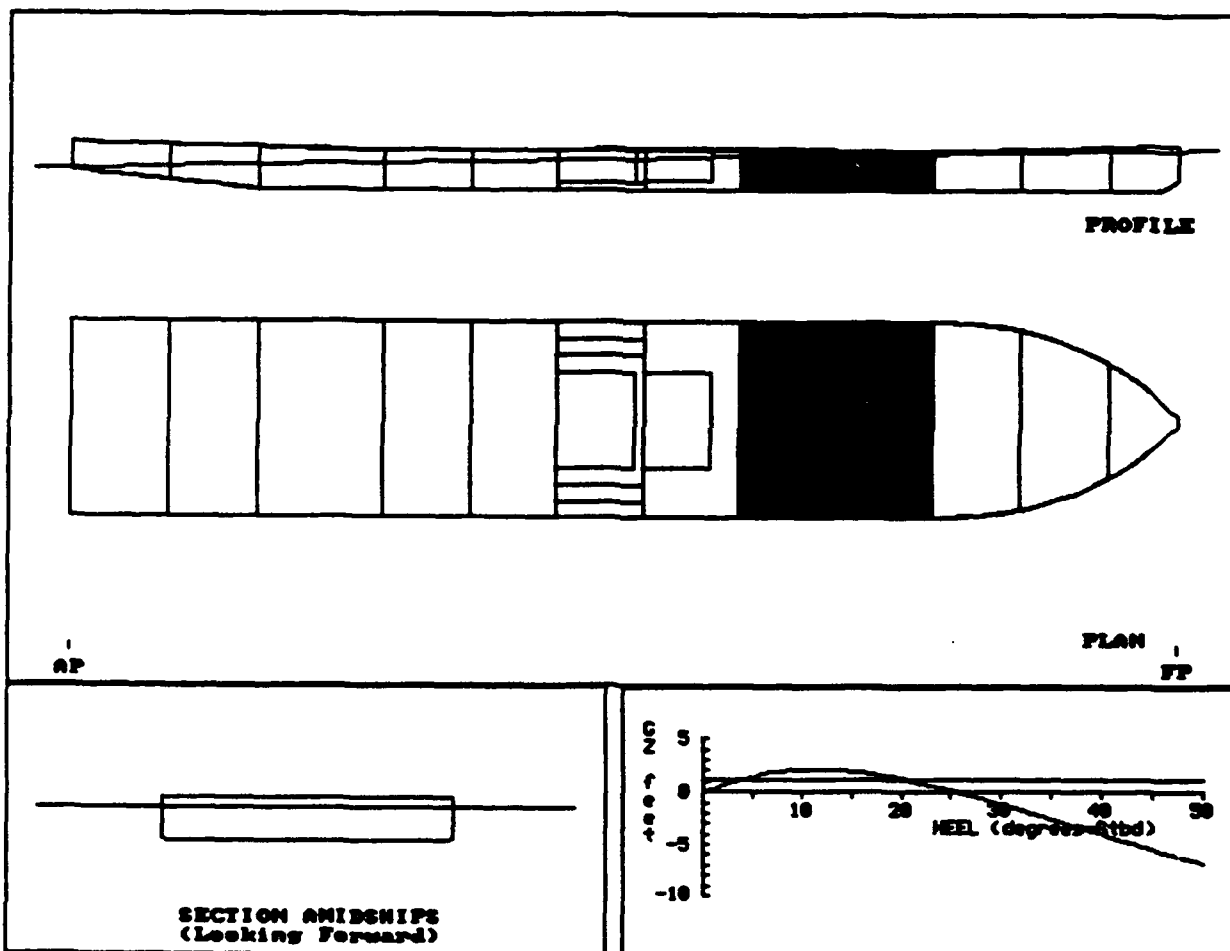

DPR005A: PUMP RMS 2,3
 228' CASINO BOAT

Leaked Compartments:
 PUMP RM 2 PUMP RM 3

	DISPLACEMENT LTONS	DRAFT AFT ft	DRAFT FWD ft	TRIM ft	HEEL deg.	UPRIGHT GMT ft
INTACT	2,408.5	7.850	7.850	0.000	0.00	22.802
DAMAGED	2,944.3	7.815	11.139	3.324F	0.00	17.279

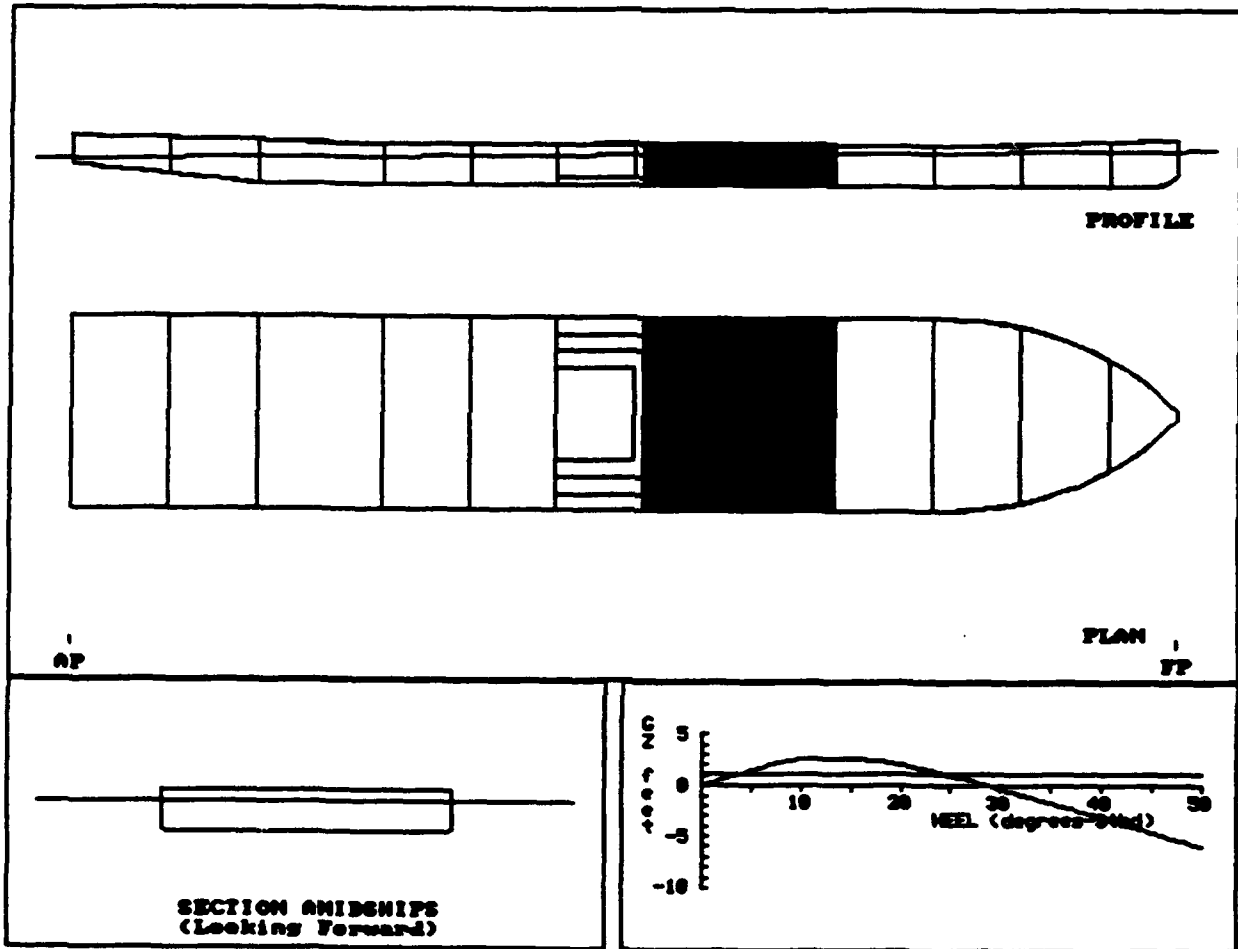

DPRT005A: PUMP RMS 2,3
 228' CASINO BOAT

COMPARTMENT FLOODING SUMMARY

At 0.0o Heel	PERM.	FLOODED WTR LTons	% FULL (Damaged)	% FULL (Intact)	SP.VOL. ft3/LT	OUTFLOW LTons
PUMP RM 2	0.95	317.6	FREE	0.0	----	----
PUMP RM 3	0.85	218.1	FREE	0.0	----	----
Totals		535.7				

INTACT DATA

Draft at AP = 7.850 ft	Kmt = 45.302 ft	LCG = 120.717A ft-FP
Draft at FP = 7.850 ft	VCG = 22.500 ft	LCB = 120.717A ft-FP
Displacement = 2408.5 LTons	Gmt = 22.802 ft	TCG = 0.000 ft-CL

DRAFT/GZ DATA

HEEL degrees	RIGHTING ARM ft	DRAFT AFT ft	DRAFT FWD ft	FLOODED WATER LTons
0.00	0.000	7.815	11.139	535.7
5.00S	1.512	7.829	11.080	534.3
7.00S	2.052	7.804	11.100	533.3
10.00S	2.571	7.720	11.351	526.5
15.00S	2.662	7.690	12.209	511.4
20.00S	2.059	7.846	13.487	498.7
25.00S	1.011	8.017	15.011	487.6
30.00S	-0.271	8.160	16.760	480.6
35.00S	-1.665	8.287	18.761	476.0
40.00S	-3.108	8.416	21.059	472.8
50.00S	-6.004	8.726	26.968	468.6

Note: Drafts are measured at A.P. and F.P along ship's centerline

GZ SUMMARY (Evaluated per IMO (SOLAS'90) Rules for Passenger Ships)

	Available	Required
Static Heel Angle	0.00 deg	7.00 deg
Angle at Maximum GZ	14.00S deg	
Maximum GZ	2.726 ft	1.160 ft
Range of Positive GZ	28.99 deg	15.00 deg
Gmt (upright damaged)	17.279 ft	
Righting Area (0.00-7.00)	43.599 ft-deg	2.820 ft-deg

DPRT006A: PUMP 2,3/H2O TMR
 228' CASINO BOAT

Imaged Compartments:

PUMP RM 2 PUMP RM 3 WATER TANK

	DISPLACEMENT LTons	DRAFT AFT ft	DRAFT FWD ft	TRIM ft	HEEL deg.	UPRIGHT GMT ft
INTACT	2,408.5	7.850	7.850	0.000	0.00	22.802
DAMAGED	2,900.8	7.771	10.930	3.159F	0.00	17.677

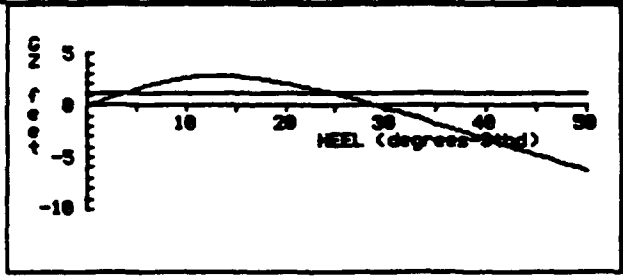
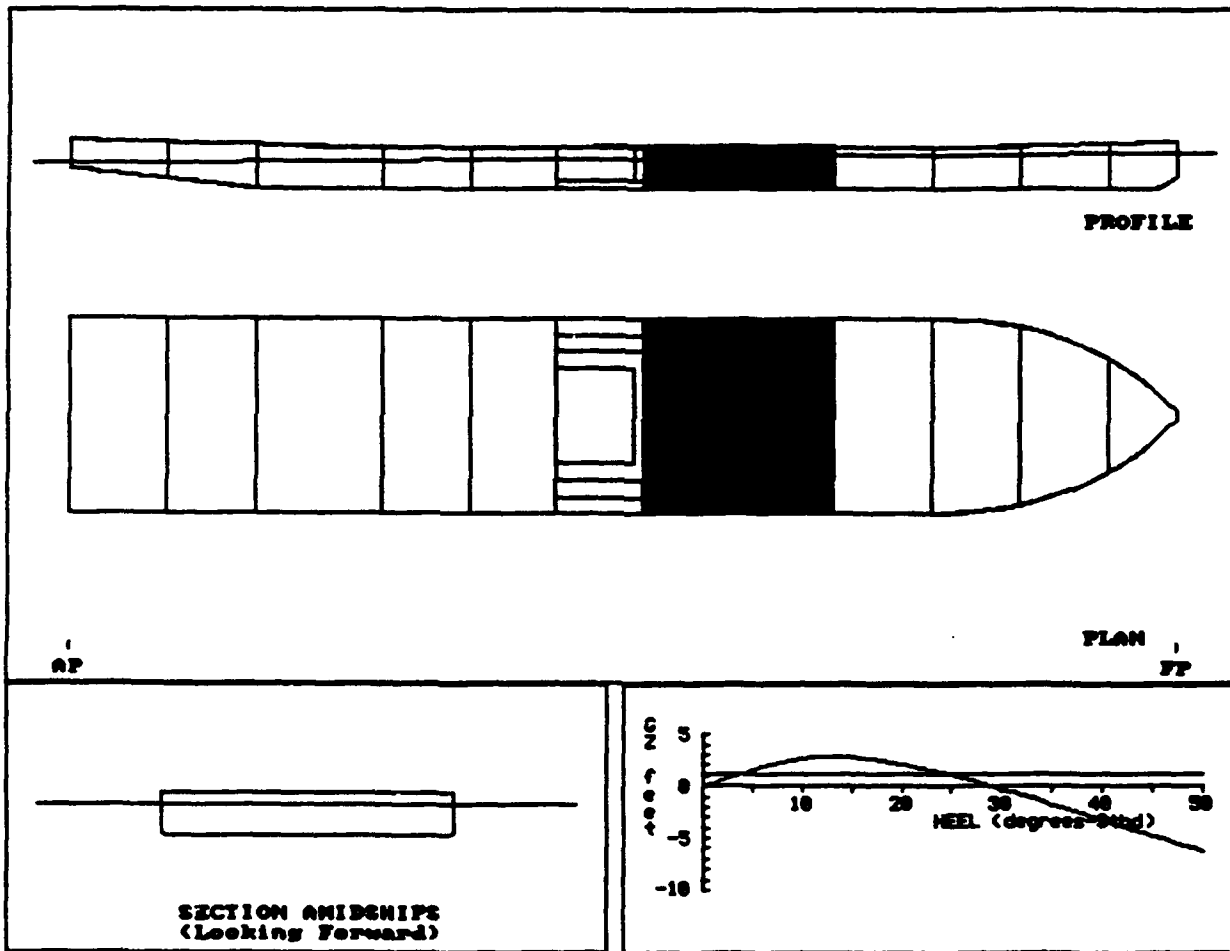

DPRT006A: PUMP 2,3/H2O TMR
 228' CASINO BOAT

COMPARTMENT FLOODING SUMMARY

At 0.0o Heel	PERM.	FLOODED WTR LTons	% FULL (Damaged)	% FULL (Intact)	SP.VOL. ft3/LT	OUTFLOW LTons
PUMP RM 2	0.95	312.7	FREE	0.0	----	----
PUMP RM 3	0.85	215.4	FREE	0.0	----	----
WATER TANK	0.95	72.2	FREE	100.0	35.8800	108.1
Totals		600.4				108.1

INTACT DATA

Draft at AP = 7.850 ft	KMT = 45.302 ft	LCG = 120.717A ft-FP
Draft at FP = 7.850 ft	VCG = 22.500 ft	LCB = 120.717A ft-FP
Displacement = 2408.5 LTons	GMT = 22.802 ft	TCG = 0.000 ft-CL

DRAFT/GZ DATA

HEEL degrees	RIGHTING ARM ft	DRAFT AFT ft	DRAFT FWD ft	FLOODED WATER LTons
0.00	0.000	7.771	10.930	600.4
5.00S	1.546	7.784	10.871	598.6
7.00S	2.117	7.763	10.870	597.5
10.00S	2.683	7.680	11.088	592.2
15.00S	2.794	7.649	11.923	582.2
20.00S	2.166	7.801	13.177	573.8
25.00S	1.062	7.963	14.665	566.0
30.00S	-0.285	8.099	16.364	561.1
35.00S	-1.747	8.223	18.298	557.9
40.00S	-3.259	8.348	20.517	555.6
50.00S	-6.291	8.643	26.223	552.5

Note: Drafts are measured at A.P. and F.P along ship's centerline

GZ SUMMARY (Evaluated per IMO (SOLAS'90) Rules for Passenger Ships)

	Available	Required
Static Heel Angle	0.00 deg	7.00 deg
Angle at Maximum GZ	14.00S deg	
Maximum GZ	2.858 ft	1.160 ft
Range of Positive GZ	28.99 deg	15.00 deg
Gmt (upright damaged)	17.677 ft	
Righting Area (0.00-7.00)	45.482 ft-deg	2.820 ft-deg

DPRT008A: PUMP 3,4/H2O
 228' CASINO BOAT

Damaged Compartments:

PUMP RM 3

WATER TANK

PUMP RM 4

	DISPLACEMENT LTons	DRAFT AFT ft	DRAFT FWD ft	TRIM ft	HEEL deg.	UPRIGHT GMT ft
INTACT	2,408.5	7.850	7.850	0.000	0.00	22.802
DAMAGED	2,697.7	8.278	9.115	0.837F	0.00	18.688

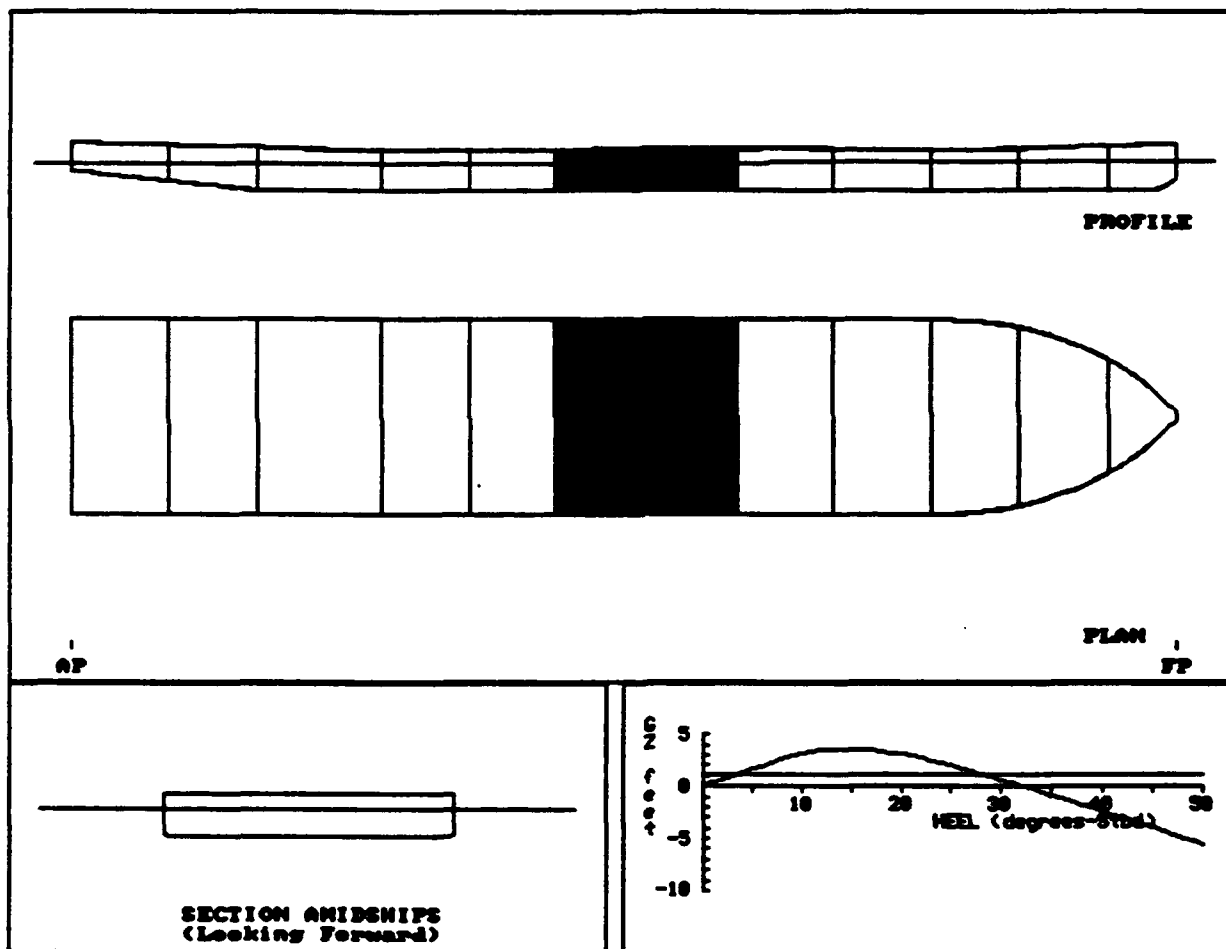

DPRT008A: PUMP 3,4/M20
 228' CASINO BOAT

COMPARTMENT FLOODING SUMMARY

At 0.0o Heel	PERM.	FLOODED WTR LTons	% FULL (Damaged)	% FULL (Intact)	SP.VOL. ft3/LT	OUTFLOW LTons
PUMP RM 3	0.85	199.5	FREE	0.0	----	----
WATER TANK	0.95	63.7	FREE	100.0	35.8800	108.1
PUMP RM 4	0.85	134.1	FREE	0.0	----	----
Totals		397.3				108.1

INTACT DATA

Draft at AP = 7.850 ft KMt = 45.302 ft LCG = 120.717A ft-FP
 Draft at FP = 7.850 ft VCG = 22.500 ft LCB = 120.717A ft-FP
 Displacement = 2408.5 LTons GMT = 22.802 ft TCG = 0.000 ft-CL

DRAFT/GZ DATA

HEEL degrees	RIGHTING ARM ft	DRAFT AFT ft	DRAFT FWD ft	FLOODED WATER LTons
0.00	0.000	8.278	9.115	397.3
5.00S	1.640	8.295	9.061	396.4
7.00S	2.300	8.298	9.018	395.5
10.00S	3.174	8.276	9.002	392.2
15.00S	3.613	8.360	9.417	382.6
20.00S	3.128	8.729	10.019	369.9
25.00S	2.033	9.102	10.732	361.5
30.00S	0.669	9.502	11.524	356.5
35.00S	-0.825	9.940	12.412	352.9
40.00S	-2.380	10.430	13.427	350.1
50.00S	-5.531	11.656	16.050	346.2

Note: Drafts are measured at A.P. and F.P along ship's centerline

GZ SUMMARY (Evaluated per IMO (SOLAS'90) Rules for Passenger Ships)

	Available	Required
Static Heel Angle	0.00 deg	7.00 deg
Angle at Maximum GZ	15.00S deg	
Maximum GZ	3.617 ft	1.160 ft
Range of Positive GZ	32.28 deg	15.00 deg
Gmt (upright damaged)	18.688 ft	
Righting Area (0.00-7.00)	56.805 ft-deg	2.820 ft-deg

DPR009A: PUMP 3,4/SEW
 228' CASINO BOAT

Damaged Compartments:

PUMP RM 3

PUMP RM 4

SEWAGE TANK

	DISPLACEMENT LTONS	DRAFT AFT ft	DRAFT FWD ft	TRIM ft	HEEL deg.	UPRIGHT GMT ft
INTACT	2,408.5	7.850	7.850	0.000	0.00	22.802
DAMAGED	2,823.0	8.520	9.591	1.070F	0.00	18.151

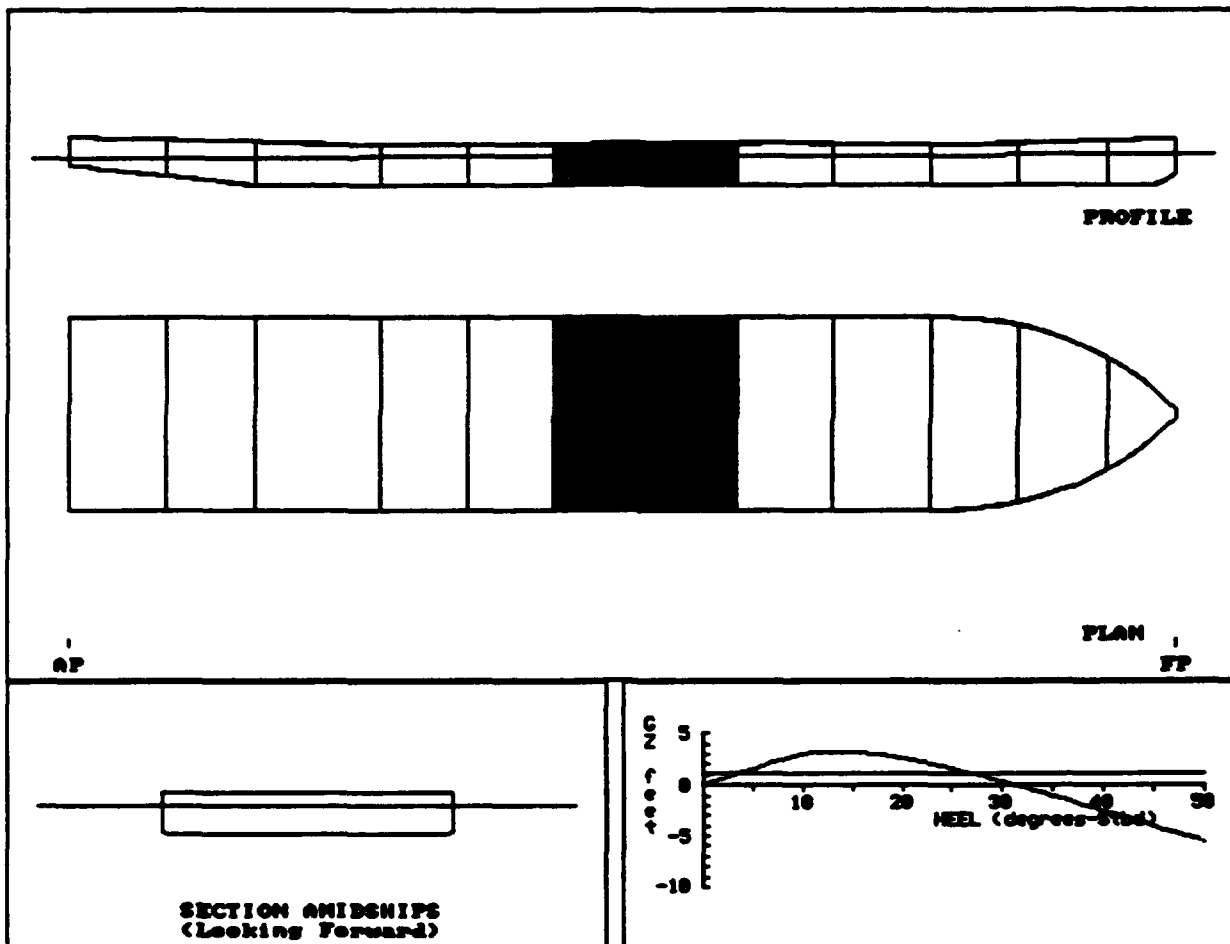

DPRT009A: PUMP 3,4/SEW
 228' CASINO BOAT

COMPARTMENT FLOODING SUMMARY

At 0.0o Heel	PERM.	FLOODED WTR LTons	% FULL (Damaged)	% FULL (Intact)	SP.VOL. ft3/LT	OUTFLOW LTons
PUMP RM 3	0.85	206.8	FREE	0.0	----	----
PUMP RM 4	0.85	138.1	FREE	0.0	----	----
SEWAGE TANK	0.95	82.9	FREE	10.0	35.0063	13.3
Totals		427.8				13.3

INTACT DATA

Draft at AP = 7.850 ft Kmt = 45.302 ft LCG = 120.717A ft-FP
 Draft at FP = 7.850 ft VCG = 22.500 ft LCB = 120.717A ft-FP
 Displacement = 2408.5 LTons GMT = 22.802 ft TCG = 0.000 ft-CL

DRAFT/GZ DATA

HEEL degrees	RIGHTING ARM ft	DRAFT AFT ft	DRAFT FWD ft	FLOODED WATER LTons
0.00	0.000	8.520	9.591	427.8
5.00S	1.594	8.539	9.535	426.9
7.00S	2.239	8.546	9.489	426.1
10.00S	2.989	8.542	9.530	422.2
15.00S	3.239	8.753	9.997	412.7
20.00S	2.718	9.242	10.747	401.9
25.00S	1.669	9.782	11.623	393.1
30.00S	0.364	10.355	12.595	387.5
35.00S	-1.062	10.979	13.691	383.6
40.00S	-2.545	11.673	14.949	380.6
50.00S	-5.546	13.407	18.202	376.2

Note: Drafts are measured at A.P. and F.P along ship's centerline

GZ SUMMARY (Evaluated per IMO (SOLAS'90) Rules for Passenger Ships)

	Available	Required
Static Heel Angle	0.00 deg	7.00 deg
Angle at Maximum GZ	15.00S deg	
Maximum GZ	3.269 ft	1.160 ft
Range of Positive GZ	31.30 deg	15.00 deg
Gmt (upright damaged)	18.151 ft	
Righting Area (0.00-7.00)	51.947 ft-deg	2.820 ft-deg

DPRT010A: PUMP 3,4/SEW/H2O
 228' CASINO BOAT

Damaged Compartments:

	PUMP RM 3	WATER TANK	PUMP RM 4	SEWAGE TANK			
	DISPLACEMENT LTONS	DRAFT AFT ft	DRAFT FWD ft	TRIM ft	HEEL deg.	UPRIGHT GMT ft	
INTACT	2,408.5	7.850	7.850	0.000	0.00	22.802	
DAMAGED	2,774.8	8.461	9.368	0.907F	0.00	18.601	

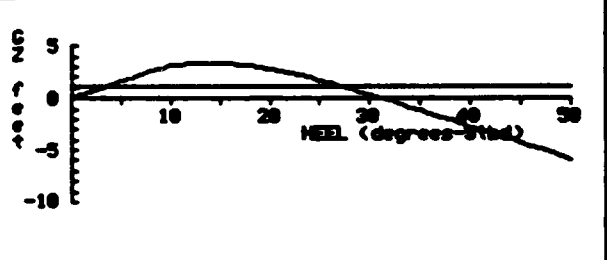
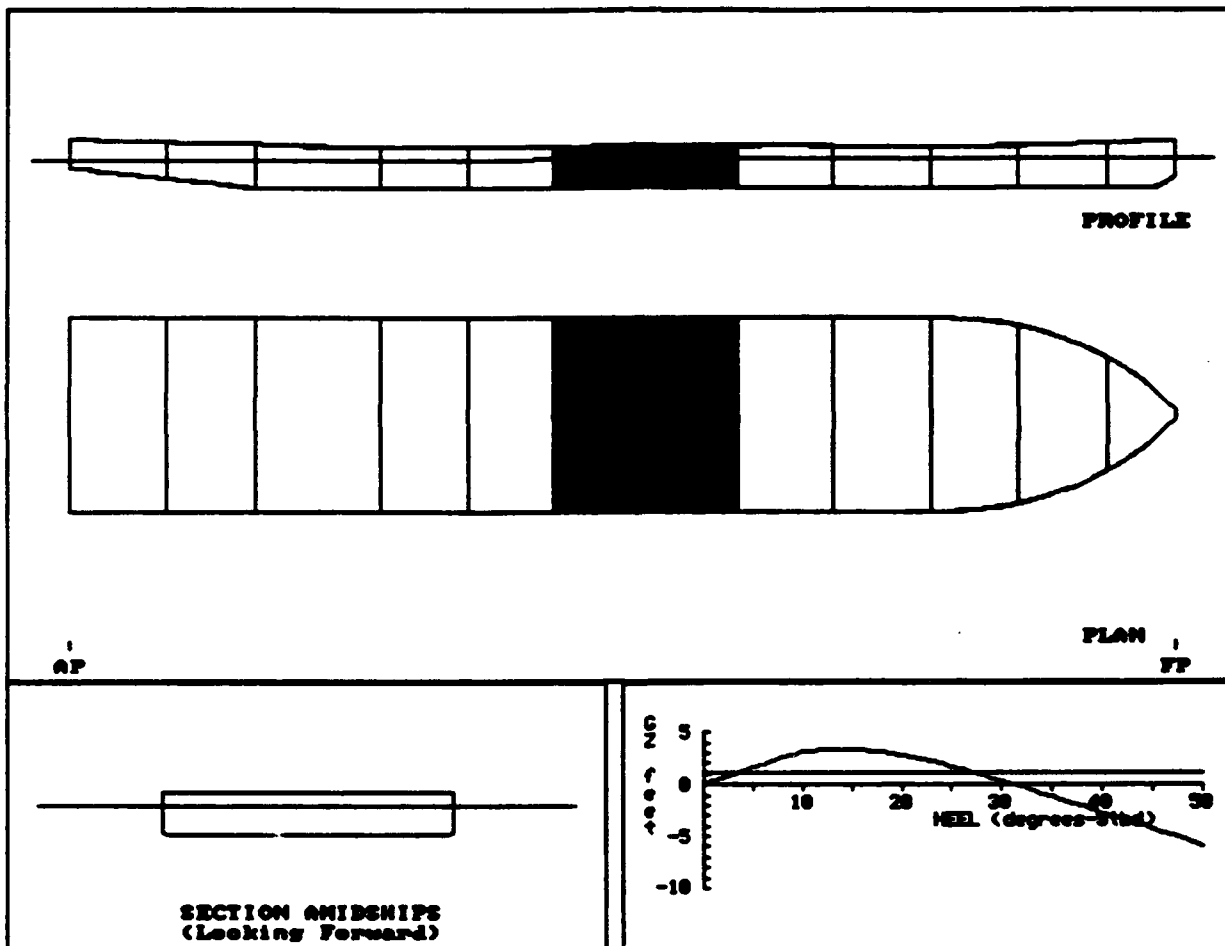

DI T010A: PUMP 3,4/SEW/H2O
 228' CASINO BOAT

COMPARTMENT FLOODING SUMMARY

At 0.0o Heel	PERM.	FLOODED WTR LTons	% FULL (Damaged)	% FULL (Intact)	SP.VOL. ft ³ /LT	OUTFLOW LTons
PUMP RM 3	0.85	203.8	FREE	0.0	----	----
WATER TANK	0.95	66.2	FREE	100.0	35.8800	108.1
PUMP RM 4	0.85	136.5	FREE	0.0	----	----
SEWAGE TANK	0.95	81.2	FREE	10.0	35.0063	13.3
Totals		487.7				121.4

INTACT DATA

Draft at AP = 7.850 ft KMT = 45.302 ft LCG = 120.717A ft-FP
 Draft at FP = 7.850 ft VCG = 22.500 ft LCB = 120.717A ft-FP
 Displacement = 2408.5 LTons GMT = 22.802 ft TCG = 0.000 ft-CL

DRAFT/GZ DATA

HEEL degrees	RIGHTING ARM ft	DRAFT AFT ft	DRAFT FWD ft	FLOODED WATER LTons
0.00	0.000	8.461	9.368	487.7
5.00S	1.634	8.479	9.312	486.6
7.00S	2.293	8.485	9.265	485.4
10.00S	3.108	8.485	9.265	481.7
15.00S	3.402	8.671	9.722	476.5
20.00S	2.850	9.141	10.451	470.2
25.00S	1.738	9.658	11.280	464.3
30.00S	0.364	10.205	12.194	460.1
35.00S	-1.133	10.801	13.217	457.0
40.00S	-2.685	11.467	14.391	454.6
50.00S	-5.826	13.130	17.428	451.3

Note: Drafts are measured at A.P. and F.P along ship's centerline

GZ SUMMARY (Evaluated per IMO (SOLAS'90) Rules for Passenger Ships)

	Available	Required
Static Heel Angle	0.00 deg	7.00 deg
Angle at Maximum GZ	15.00S deg	
Maximum GZ	3.431 ft	1.160 ft
Range of Positive GZ	31.24 deg	15.00 deg
Gmt (upright damaged)	18.601 ft	
Righting Area (0.00- \pm .00)	54.145 ft-deg	2.820 ft-deg

DPR011A: PUMP 3,4/SEW/H2O/FUEL (P)
 228' CASINO BOAT

Damaged Compartments:

	PUMP RM 3	WATER TANK	PUMP RM 4	SEWAGE TANK	FUEL TANK (P)		
	DISPLACEMENT LTons	DRAFT AFT ft	DRAFT FWD ft	TRIM ft	HEEL deg.	UPRIGHT GMT ft	
INTACT	2,408.5	7.850	7.850	0.000	0.00	22.802	
DAMAGED	2,765.4	8.441	9.335	0.894F	0.24S	18.225	

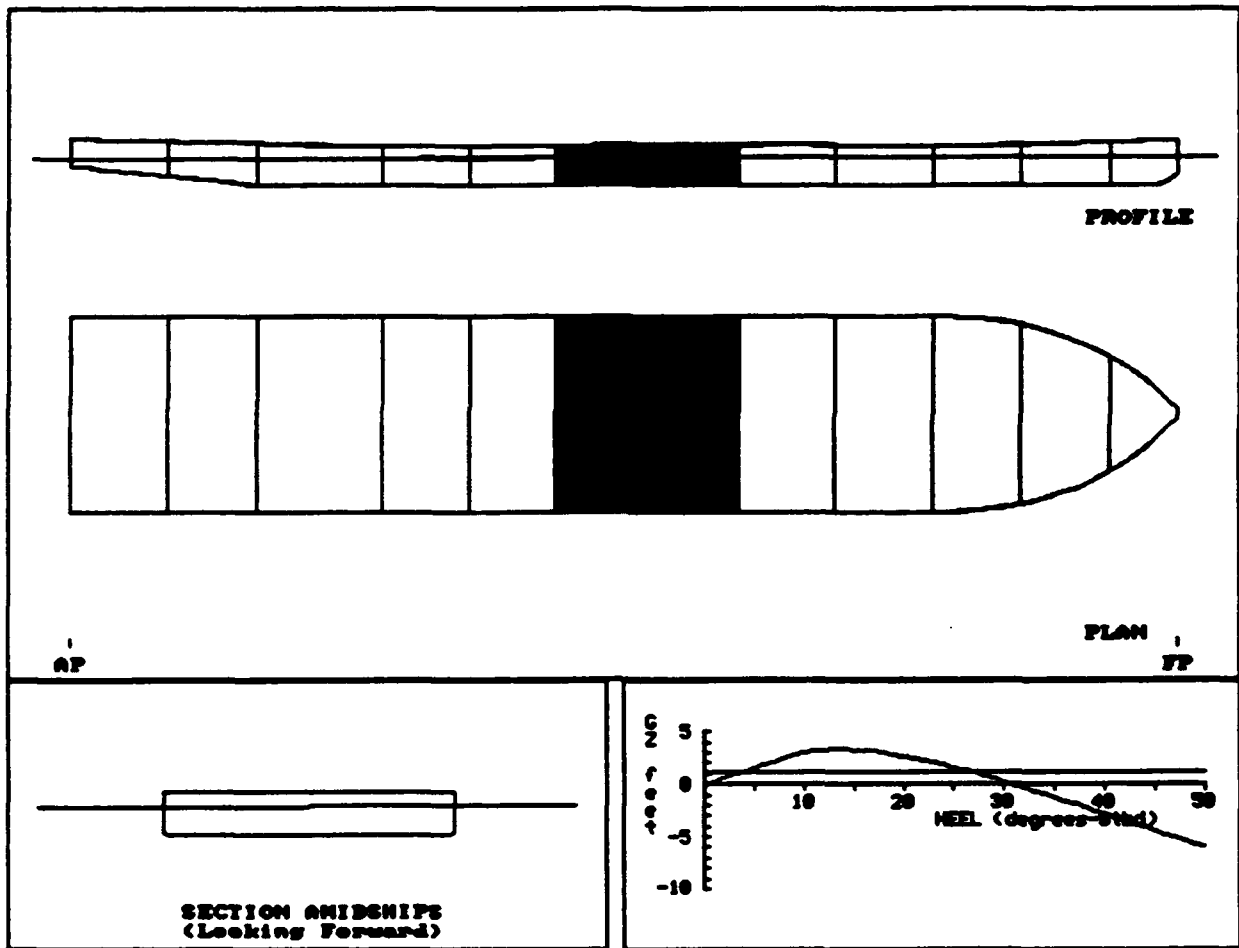

DPRT011A: PUMP 3,4/SEW/H2O/FUEL (P)
 228' CASINO BOAT

COMPARTMENT FLOODING SUMMARY

At 0.2oS Heel	PERM.	FLOODED WTR LTons	% FULL (Damaged)	% FULL (Intact)	SP.VOL. ft3/LT	OUTFLOW LTons
PUMP RM 3	0.85	203.3	FREE	0.0	----	----
WATER TANK	0.95	65.9	FREE	100.0	35.8800	108.1
PUMP RM 4	0.85	136.2	FREE	0.0	----	----
SEWAGE TANK	0.95	80.8	FREE	10.0	35.0063	13.3
FUEL TNK (P)	0.95	15.3	FREE	100.0	38.5800	23.2
Totals		501.5				144.6

INTACT DATA

Draft at AP = 7.850 ft KMT = 45.302 ft LCG = 120.717A ft-FP
 Draft at FP = 7.850 ft VCG = 22.500 ft LCB = 120.717A ft-FP
 Displacement = 2408.5 LTons GMT = 22.802 ft TCG = 0.000 ft-CL

DRAFT/GZ DATA

HEEL degrees	RIGHTING ARM ft	DRAFT AFT ft	DRAFT FWD ft	FLOODED WATER LTons
0.00	-0.076	8.440	9.338	501.9
5.00S	1.525	8.446	9.260	494.9
7.00S	2.169	8.445	9.207	491.4
10.00S	2.977	8.425	9.198	484.2
15.00S	3.274	8.552	9.642	473.7
20.00S	2.724	9.012	10.307	465.3
25.00S	1.606	9.488	11.102	459.4
30.00S	0.225	9.993	11.978	455.2
35.00S	-1.279	10.543	12.958	452.1
40.00S	-2.839	11.158	14.081	449.8
50.00S	-5.989	12.696	16.986	446.4

Note: Drafts are measured at A.P. and F.P along ship's centerline

GZ SUMMARY (Evaluated per IMO (SOLAS'90) Rules for Passenger Ships)

	Available	Required
Static Heel Angle	0.24S deg	7.00 deg
Angle at Maximum GZ	15.00S deg	
Maximum GZ	3.302 ft	1.160 ft
Range of Positive GZ	30.53 deg	15.00 deg
Righting Area (0.24-1.00)	51.541 ft-deg	2.820 ft-deg

DPRT012A: PUMP 3,4/SEW/FUEL (P)
 228' CASINO BOAT

Damaged Compartments:

PUMP RM 3 PUMP RM 4 SEWAGE TANK FUEL TANK (P)

	DISPLACEMENT LTons	DRAFT AFT ft	DRAFT FWD ft	TRIM ft	HEEL deg.	UPRIGHT GMT ft
INTACT	2,408.5	7.850	7.850	0.000	0.00	22.802
DAMAGED	2,814.4	8.501	9.561	1.059F	0.22S	17.789

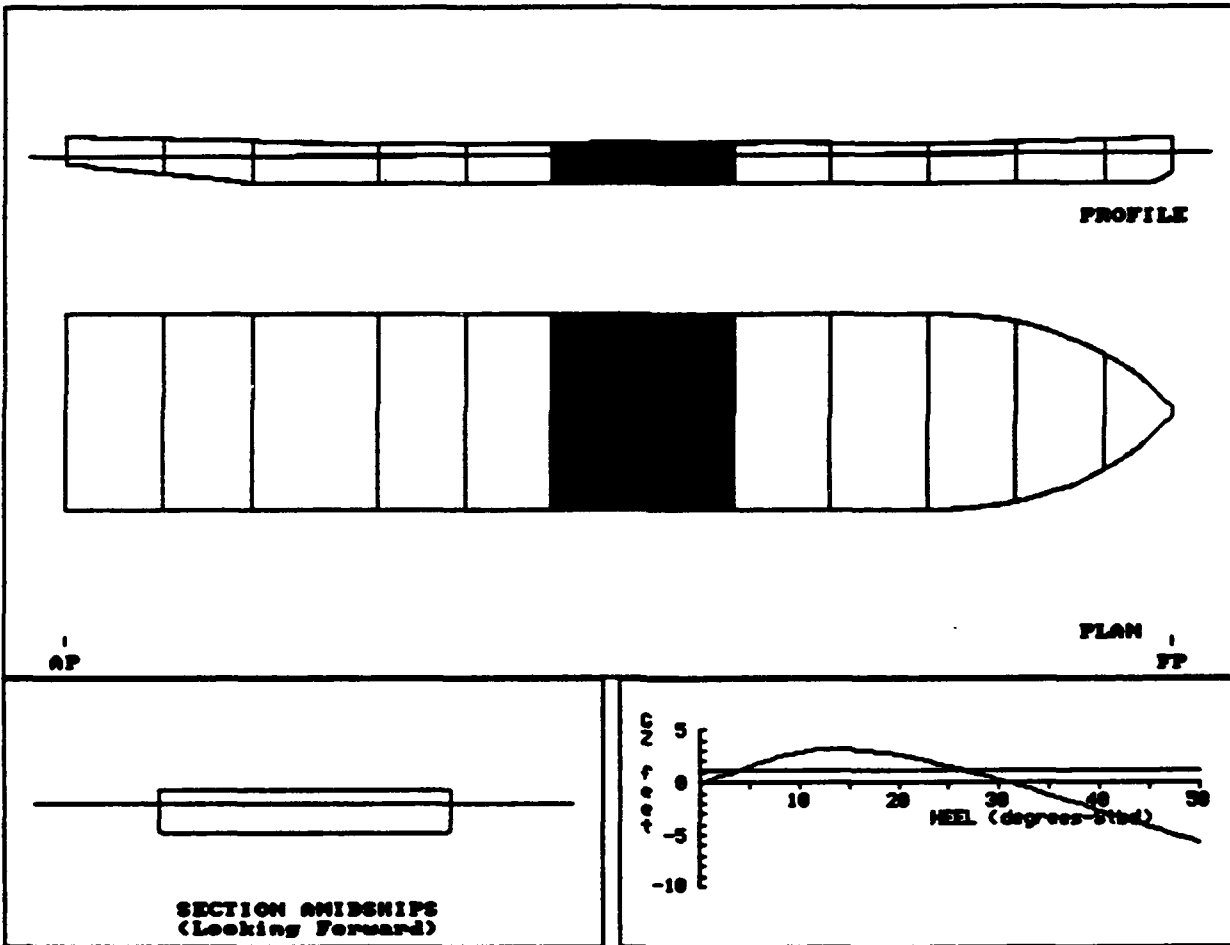

DPRT012A: PUMP 3,4/SEW/FUEL (P)
 228' CASINO BOAT

COMPARTMENT FLOODING SUMMARY

At 0.2oS Heel	PERM.	FLOODED WTR LTons	% FULL (Damaged)	% FULL (Intact)	SP.VOL. ft ³ /LT	OUTFLOW LTons
PUMP RM 3	0.85	206.3	FREE	0.0	----	----
PUMP RM 4	0.85	137.8	FREE	0.0	----	----
SEWAGE TANK	0.95	82.6	FREE	10.0	35.0063	13.3
FUEL TNK (P)	0.95	15.7	FREE	100.0	38.5800	23.2
Totals		442.4				36.5

INTACT DATA

Draft at AP = 7.850 ft Kmt = 45.302 ft LCG = 120.717A ft-FP
 Draft at FP = 7.850 ft VCG = 22.500 ft LCB = 120.717A ft-FP
 Displacement = 2408.5 LTons GMT = 22.802 ft TCG = 0.000 ft-CL

DRAFT/GZ DATA

HEEL degrees	RIGHTING ARM ft	DRAFT AFT ft	DRAFT FWD ft	FLOODED WATER LTons
0.00	-0.069	8.501	9.563	442.7
5.00S	1.493	8.508	9.488	436.2
7.00S	2.124	8.508	9.436	433.1
10.00S	2.871	8.508	9.436	425.8
15.00S	3.120	8.637	9.924	411.6
20.00S	2.599	9.117	10.612	398.4
25.00S	1.545	9.618	11.456	389.7
30.00S	0.234	10.150	12.395	384.2
35.00S	-1.198	10.730	13.450	380.3
40.00S	-2.686	11.376	14.660	377.3
50.00S	-5.697	12.989	17.789	373.0

Note: Drafts are measured at A.P. and F.P along ship's centerline

GZ SUMMARY (Evaluated per IMO (SOLAS'90) Rules for Passenger Ships)

	Available	Required
Static Heel Angle	0.22S deg	7.00 deg
Angle at Maximum GZ	15.00S deg	
Maximum GZ	3.150 ft	1.160 ft
Range of Positive GZ	30.61 deg	15.00 deg
Righting Area (0.22-7.00)	49.537 ft-deg	2.820 ft-deg

DPR013A: PUMP 3,4/H2O/FUEL (P)
 228' CASINO BOAT

Imaged Compartments:

	PUMP RM 3	PUMP RM 4	FUEL TANK (P)	WATER TANK			
	DISPLACEMENT		DRAFT AFT	DRAFT FWD	TRIM	HEEL	UPRIGHT Gmt
	LTons		ft	ft	ft	deg.	ft
INTACT	2,408.5		7.850	7.850	0.000	0.00	22.802
DAMAGED	2,688.0		8.257	9.080	0.823F	0.25S	18.316

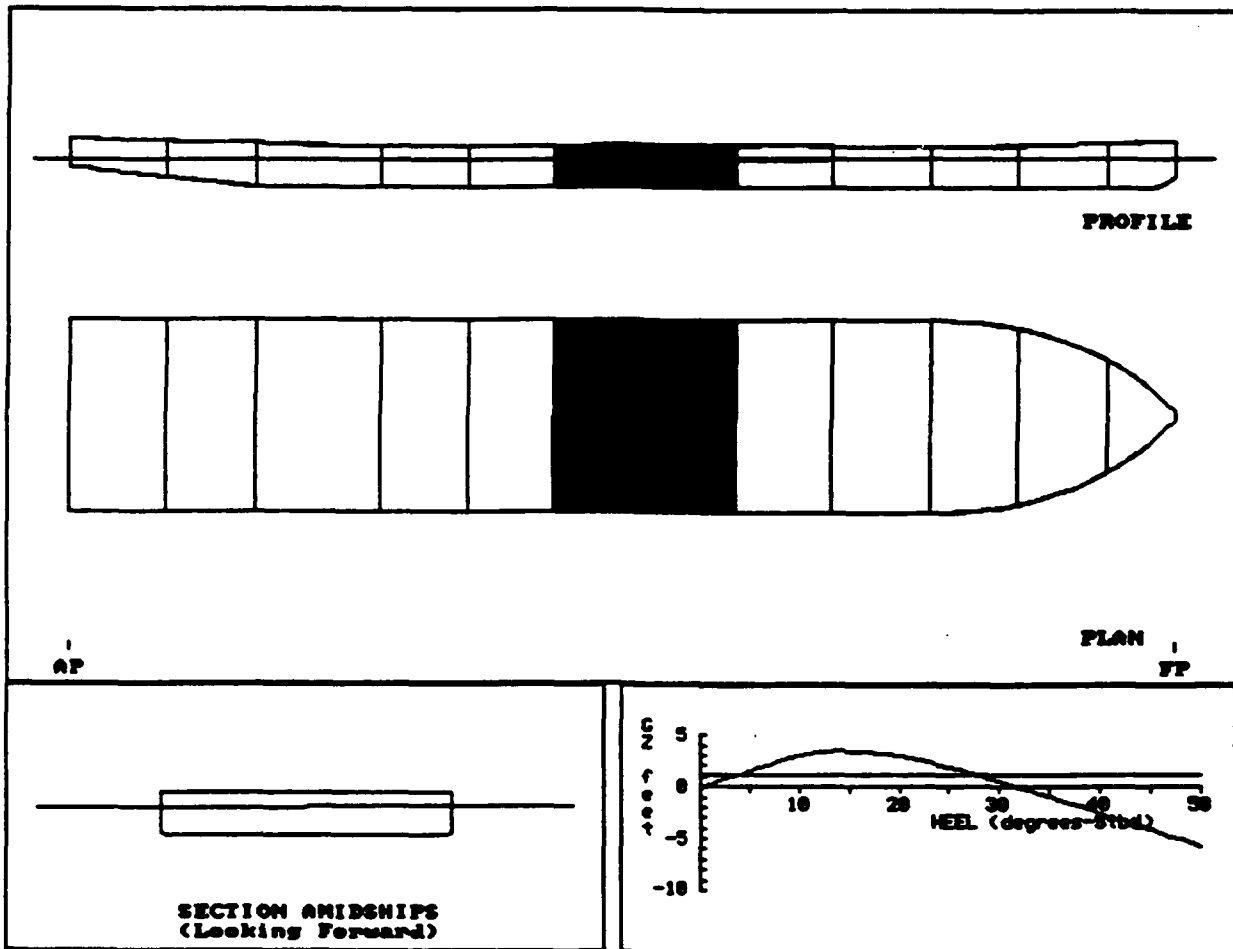

DPRT013A: PUMP 3,4/H2O/FUEL (P)
 228' CASINO BOAT

COMPARTMENT FLOODING SUMMARY

At 0.3oS Heel	PERM.	FLOODED WTR LTons	% FULL (Damaged)	% FULL (Intact)	SP.VOL. ft ³ /LT	OUTFLOW LTons
PUMP RM 3	0.85	198.9	FREE	0.0	----	----
PUMP RM 4	0.85	133.8	FREE	0.0	----	----
FUEL TNK (P)	0.95	14.8	FREE	100.0	38.5800	23.2
WATER TANK	0.95	63.4	FREE	100.0	35.8800	108.1
Totals		410.8				131.3

INTACT DATA

Draft at AP = 7.850 ft KMT = 45.302 ft LCG = 120.717A ft-FP
 Draft at FP = 7.850 ft VCG = 22.500 ft LCB = 120.717A ft-FP
 Displacement = 2408.5 LTons GMT = 22.802 ft TCG = 0.000 ft-CL

DRAFT/GZ DATA

HEEL degrees	RIGHTING ARM ft	DRAFT AFT ft	DRAFT FWD ft	FLOODED WATER LTons
0.00	-0.081	8.257	9.084	411.2
5.00S	1.527	8.263	9.009	404.7
7.00S	2.171	8.258	8.960	401.5
10.00S	3.035	8.224	8.926	394.9
15.00S	3.476	8.277	9.305	380.3
20.00S	2.993	8.607	9.884	366.6
25.00S	1.894	8.943	10.567	358.5
30.00S	0.523	9.305	11.325	353.5
35.00S	-0.977	9.699	12.174	349.9
40.00S	-2.539	10.142	13.144	347.2
50.00S	-5.698	11.252	15.648	343.2

Note: Drafts are measured at A.P. and F.P along ship's centerline

GZ SUMMARY (Evaluated per IMO (SOLAS'90) Rules for Passenger Ships)

	Available	Required
Static Heel Angle	0.25S deg	7.00 deg
Angle at Maximum GZ	15.00S deg	
Maximum GZ	3.479 ft	1.160 ft
Range of Positive GZ	31.53 deg	15.00 deg
Righting Area (0.25-4.00)	54.044 ft-deg	2.820 ft-deg

DPRT014A: PUMP 3,4/FUEL (P)
 228' CASINO BOAT

Damaged Compartments:

PUMP RN 3 PUMP RN 4 FUEL TANK (P)

	DISPLACEMENT LTons	DRAFT AFT ft	DRAFT FWD ft	TRIM ft	HEEL deg.	UPRIGHT GNT ft
INTACT	2,408.5	7.850	7.850	0.000	0.00	22.802
DAMAGED	2,737.8	8.315	9.314	0.999F	0.24S	17.876

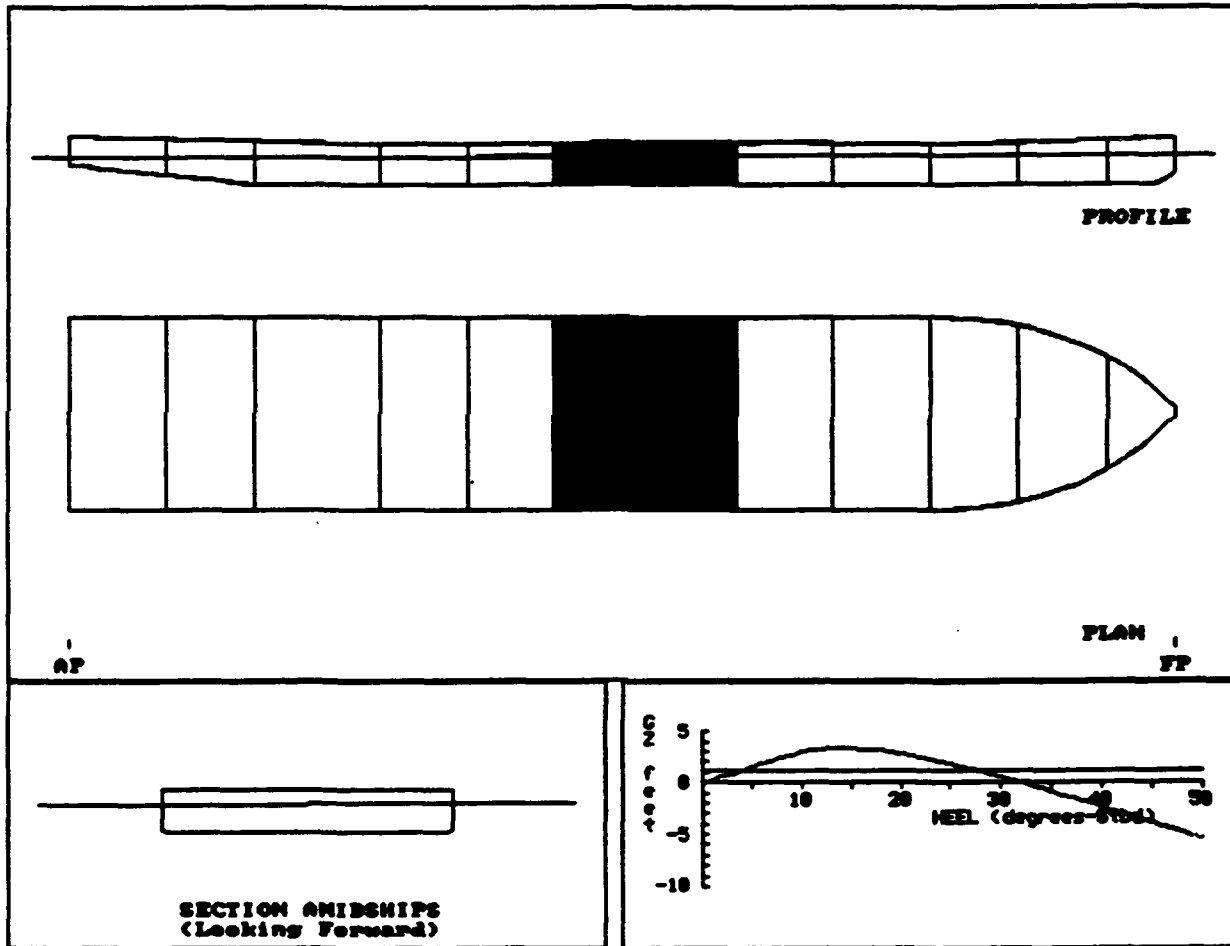

DPRT014A: PUMP 3,4/FUEL (P)
 228' CASINO BOAT

COMPARTMENT FLOODING SUMMARY

At 0.2oS Heel	PERM.	FLOODED WTR LTons	% FULL (Damaged)	% FULL (Intact)	SP.VOL. ft ³ /LT	OUTFLOW LTons
PUMP RM 3	0.85	202.0	FREE	0.0	----	----
PUMP RM 4	0.85	135.4	FREE	0.0	----	----
FUEL TNK (P)	0.95	15.1	FREE	100.0	38.5800	23.2
Totals		352.5				23.2

INTACT DATA

Draft at AP = 7.850 ft KMT = 45.302 ft LCG = 120.717A ft-FP
 Draft at FP = 7.850 ft VCG = 22.500 ft LCB = 120.717A ft-FP
 Displacement = 2408.5 LTons GMT = 22.802 ft TCG = 0.000 ft-CL

DRAFT/GZ DATA

HEEL degrees	RIGHTING ARM ft	DRAFT AFT ft	DRAFT FWD ft	FLOODED WATER LTons
0.00	-0.074	8.315	9.318	352.8
5.00S	1.496	8.322	9.244	346.8
7.00S	2.126	8.320	9.196	344.0
10.00S	2.936	8.290	9.185	337.4
15.00S	3.320	8.359	9.594	319.5
20.00S	2.869	8.712	10.204	301.5
25.00S	1.832	9.075	10.944	291.0
30.00S	0.530	9.465	11.771	284.9
35.00S	-0.899	9.891	12.700	280.5
40.00S	-2.390	10.366	13.762	277.2
50.00S	-5.412	11.555	16.507	272.3

Note: Drafts are measured at A.P. and F.P along ship's centerline

GZ SUMMARY (Evaluated per IMO (SOLAS'90) Rules for Passenger Ships)

	Available	Required
Static Heel Angle	0.24S deg	7.00 deg
Angle at Maximum GZ	15.00S deg	
Maximum GZ	3.327 ft	1.160 ft
Range of Positive GZ	31.66 deg	15.00 deg
Righting Area (0.24-1.00)	52.063 ft-deg	2.820 ft-deg

DPRT015A: PUMP 4/STORES 1
 228' CASINO BOAT

Damaged Compartments:
 PUMP RM 4 STORES1

	DISPLACEMENT LTons	DRAFT AFT ft	DRAFT FWD ft	TRIM ft	HEEL deg.	UPRIGHT GMT ft
INTACT	2,408.5	7.850	7.850	0.000	0.00	22.802
DAMAGED	2,808.6	9.191	8.713	0.478A	0.00	17.823

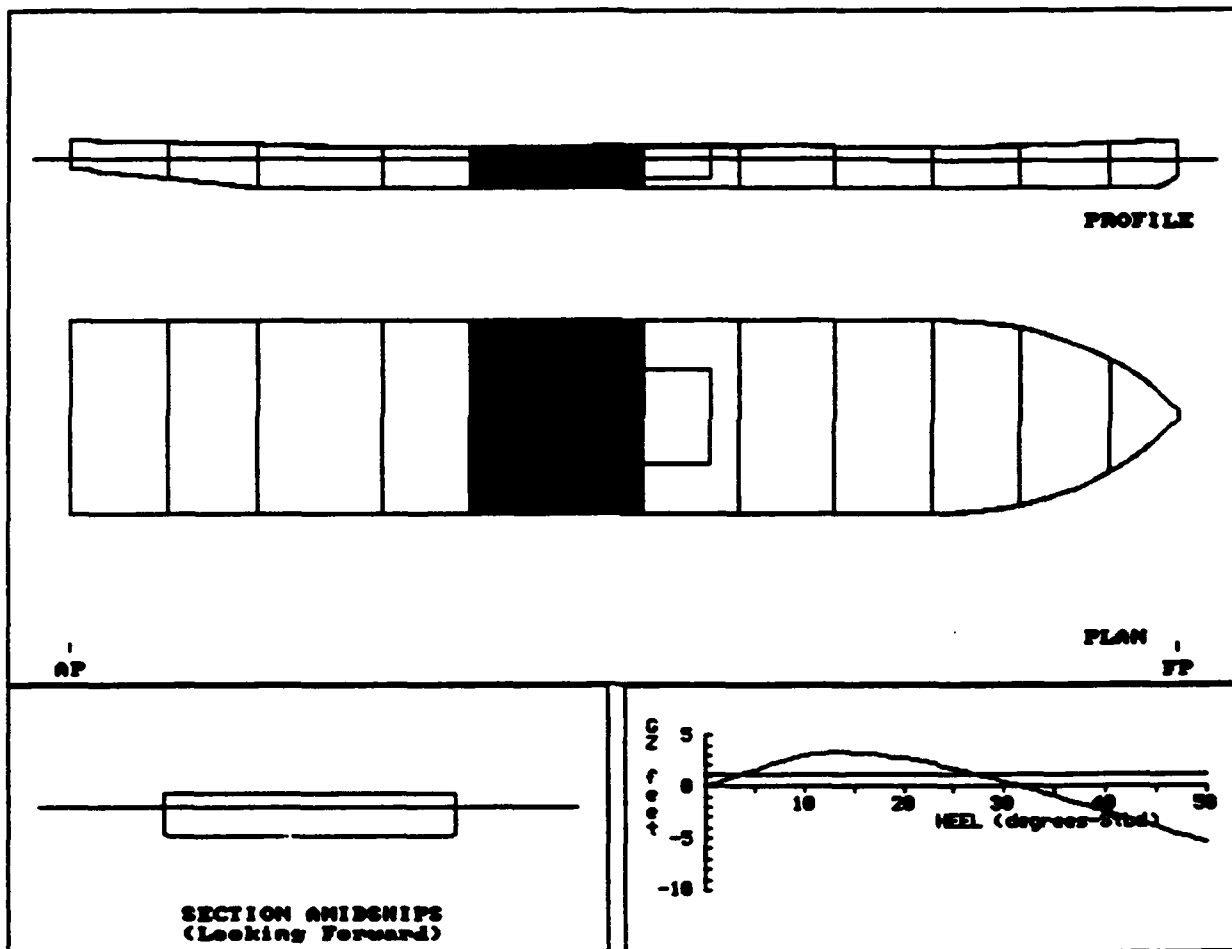

DPRT015A: PUMP 4/STORES 1
 228' CASINO BOAT

COMPARTMENT FLOODING SUMMARY

At 0.0o Heel	PERM.	FLOODED WTR LTons	% FULL (Damaged)	% FULL (Intact)	SP.VOL. ft3/LT	OUTFLO. LTons
PUMP RM 4	0.85	137.2	FREE	0.0	----	----
STORES1	0.95	262.8	FREE	0.0	----	----
Totals		400.1				

INTACT DATA

Draft at AP = 7.850 ft	KMt = 45.302 ft	LCG = 120.717A ft-FP
Draft at FP = 7.850 ft	VCG = 22.500 ft	LCB = 120.717A ft-FP
Displacement = 2408.5 LTons	GMT = 22.802 ft	TCG = 0.000 ft-CL

DRAFT/GZ DATA

HEEL degrees	RIGHTING ARM ft	DRAFT AFT ft	DRAFT FWD ft	FLOODED WATER LTons
0.00	0.000	9.191	8.713	400.1
5.00S	1.566	9.213	8.658	399.6
7.00S	2.206	9.226	8.611	399.1
10.00S	3.003	9.275	8.578	395.5
15.00S	3.270	9.697	8.824	385.5
20.00S	2.765	10.432	9.303	373.7
25.00S	1.728	11.275	9.832	364.6
30.00S	0.434	12.194	10.414	358.9
35.00S	-0.981	13.205	11.070	355.1
40.00S	-2.454	14.347	11.815	352.2
50.00S	-5.440	17.249	13.716	347.9

Note: Drafts are measured at A.P. and F.P along ship's centerline

GZ SUMMARY (Evaluated per IMO (SOLAS'90) Rules for Passenger Ships)

	Available	Required
Static Heel Angle	0.00 deg	7.00 deg
Angle at Maximum GZ	15.00S deg	
Maximum GZ	3.300 ft	1.160 ft
Range of Positive GZ	31.57 deg	15.00 deg
Gmt (upright damaged)	17.823 ft	
Righting Area (0.00-7.00)	52.212 ft-deg	2.820 ft-deg

DPR016A: PUMP 4/STORES 1/FUEL
 228' CASINO BOAT

Managed Compartments:

PUMP RM 4

STORES1

FUEL TNK (P)

	DISPLACEMENT LTons	DRAFT AFT ft	DRAFT FWD ft	TRIM ft	HEEL deg.	UPRIGHT GMT ft
INTACT	2,408.5	7.850	7.850	0.000	0.00	22.802
DAMAGED	2,799.9	9.171	8.684	0.487A	0.23S	17.461

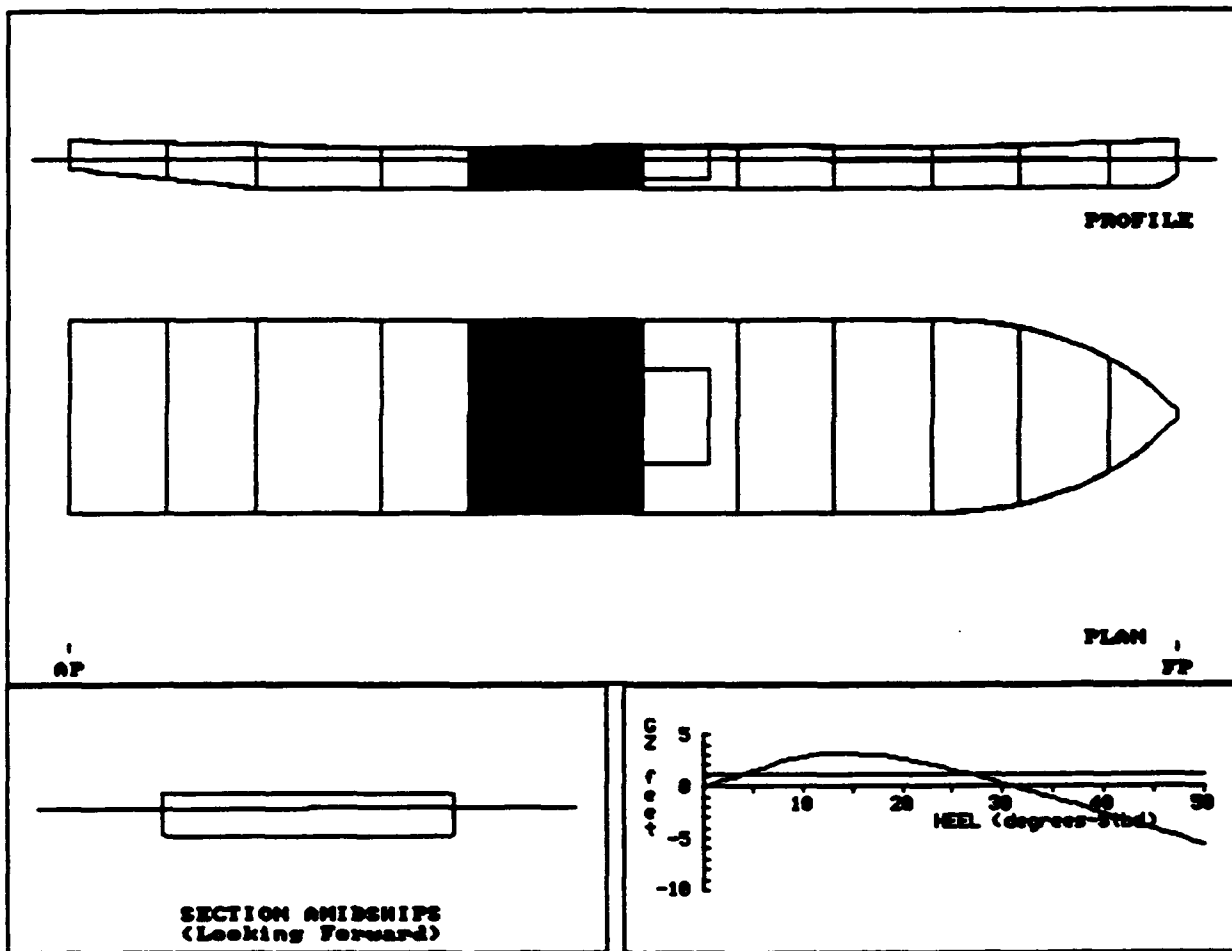

DPRT016A: PUMP 4/STORES 1/FUEL
 228' CASINO BOAT

COMPARTMENT FLOODING SUMMARY

At 0.2oS Heel	PERM.	FLOODED WTR LTons	% FULL (Damaged)	% FULL (Intact)	SP.VOL. ft ³ /LT	OUTFLOW LTons
PUMP RM 4	0.85	136.9	FREE	0.0	----	----
STORES1	0.95	262.1	FREE	0.0	----	----
FUEL TNK (P)	0.95	15.5	FREE	100.0	38.5800	23.2
Totals		414.6				23.2

INTACT DATA

Draft at AP = 7.850 ft KMT = 45.302 ft LCG = 120.717A ft-FP
 Draft at FP = 7.850 ft VCG = 22.500 ft LCB = 120.717A ft-FP
 Displacement = 2408.5 LTons GMT = 22.802 ft TCG = 0.000 ft-CL

DRAFT/GZ DATA

HEEL degrees	RIGHTING ARM ft	DRAFT AFT ft	DRAFT FWD ft	FLOODED WATER LTons
0.00	-0.070	9.170	8.687	414.9
5.00S	1.464	9.180	8.611	408.9
7.00S	2.091	9.186	8.560	406.2
10.00S	2.883	9.222	8.510	399.3
15.00S	3.152	9.602	8.733	384.5
20.00S	2.647	10.297	9.184	370.6
25.00S	1.605	11.098	9.689	361.6
30.00S	0.306	11.971	10.244	356.0
35.00S	-1.116	12.932	10.868	352.3
40.00S	-2.594	14.017	11.579	349.4
50.00S	-5.589	16.774	13.390	345.1

Note: Drafts are measured at A.P. and F.P along ship's centerline

GZ SUMMARY (Evaluated per IMO (SOLAS'90) Rules for Passenger Ships)

	Available	Required
Static Heel Angle	0.23S deg	7.00 deg
Angle at Maximum GZ	15.00S deg	
Maximum GZ	3.181 ft	1.160 ft
Range of Positive GZ	30.87 deg	15.00 deg
Righting Area (0.23-1.00)	49.789 ft-deg	2.820 ft-deg

DPR017A: PUMP 4/STORES 1/FUEL/SEW
 228' CASINO BOAT

Imaged Compartments:

	PUMP RM 4	STORES1	FUEL TANK (P)	SEWAGE TANK			
	DISPLACEMENT LTons	DRAFT AFT ft	DRAFT FWD ft	TRIM ft	HEEL deg.	UPRIGHT CNT ft	
INTACT	2,408.5	7.850	7.850	0.000	0.00	22.802	
DAMAGED	2,881.0	9.383	8.928	0.455A	0.22S	17.380	

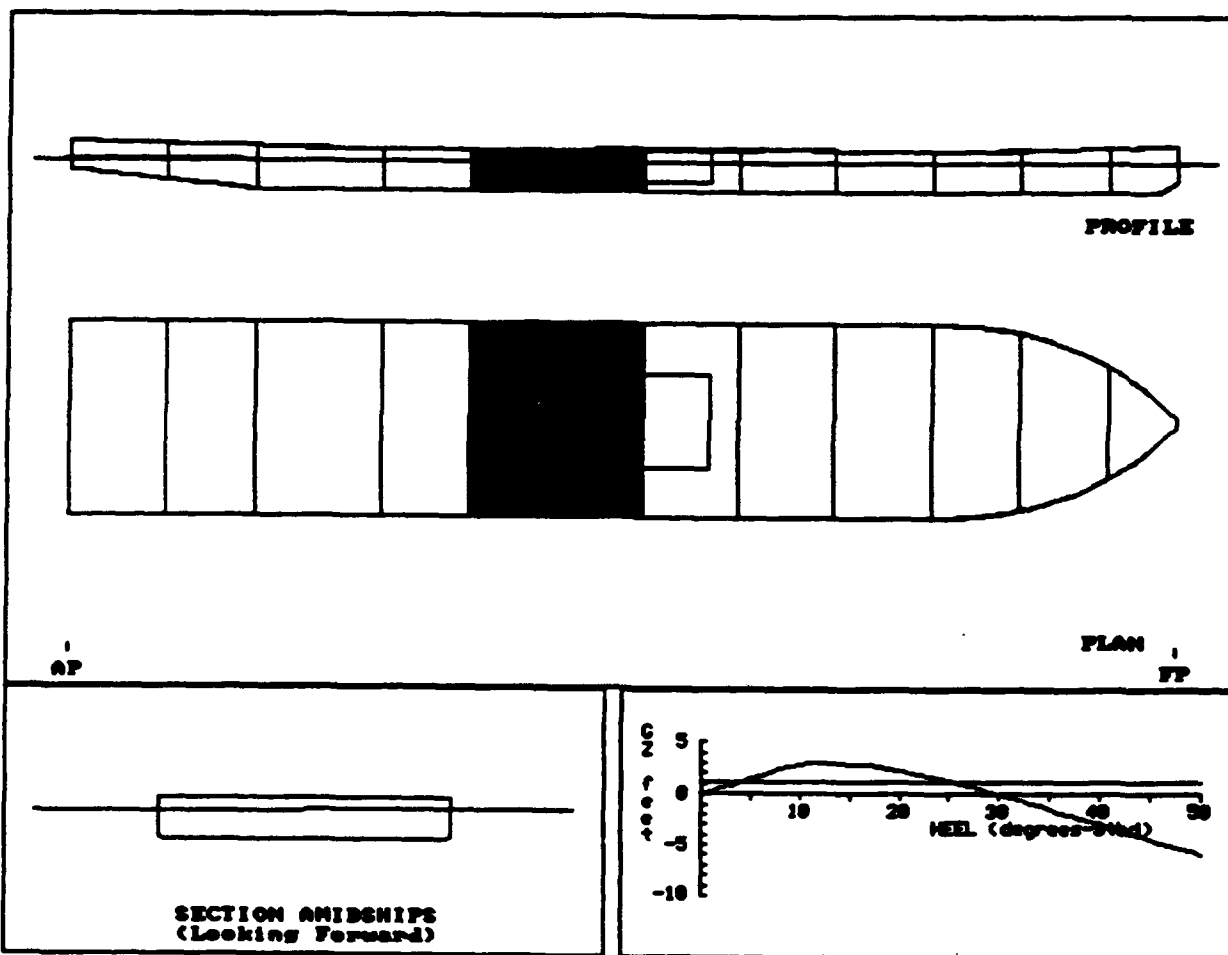

DPR017A: PUMP 4/STORES 1/FUEL/SEW
 228' CASINO BOAT

COMPARTMENT FLOODING SUMMARY

At 0.2oS Heel	PERM.	FLOODED WTR LTons	% FULL (Damaged)	% FULL (Intact)	SP.VOL. ft3/LT	OUTFLOW LTons
PUMP RM 4	0.85	139.5	FREE	0.0	----	----
STORES1	0.95	268.7	FREE	0.0	----	----
FUEL TNK (P)	0.95	16.1	FREE	100.0	38.5800	23.2
SEWAGE TANK	0.95	84.7	FREE	10.0	35.0063	13.3
Totals		509.0				36.5

INTACT DATA

Draft at AP = 7.850 ft Kmt = 45.302 ft LCG = 120.717A ft-FP
 Draft at FP = 7.850 ft VCG = 22.500 ft LCB = 120.717A ft-FP
 Displacement = 2408.5 LTons Gmt = 22.802 ft TCG = 0.000 ft-CL

DRAFT/GS DATA

HEEL degrees	RIGHTING ARM ft	DRAFT AFT ft	DRAFT FWD ft	FLOODED WATER LTons
0.00	-0.066	9.382	8.931	509.2
5.00S	1.461	9.391	8.853	502.8
7.00S	2.086	9.398	8.800	499.8
10.00S	2.798	9.456	8.778	492.8
15.00S	2.913	9.947	9.050	483.5
20.00S	2.331	10.778	9.585	475.6
25.00S	1.276	11.751	10.193	469.7
30.00S	-0.029	12.806	10.857	465.6
35.00S	-1.450	13.970	11.598	462.5
40.00S	-2.926	15.277	12.440	460.0
50.00S	-5.902	18.596	14.594	456.4

Note: Drafts are measured at A.P. and F.P along ship's centerline

GZ SUMMARY (Evaluated per IMO (SOLAS'90) Rules for Passenger Ships)
 Available Required

Static Heel Angle	0.22S deg	7.00 deg
Angle at Maximum GZ	14.00S deg	
Maximum GZ	2.995 ft	1.160 ft
Range of Positive GZ	29.68 deg	15.00 deg
Righting Area (0.22-8.00)	46.772 ft-deg	2.820 ft-deg

DPRT018A: PUMP 4/STORES 1/SEW
 228' CASINO BOAT

Damaged Compartments:

PUMP RM 4 STORES1 SEWAGE TANK

	DISPLACEMENT LTons	DRAFT AFT ft	DRAFT FWD ft	TRIM ft	HEEL deg.	UPRIGHT GMT ft
INTACT	2,408.5	7.850	7.850	0.000	0.00	22.802
DAMAGED	2,889.4	9.403	8.956	0.447A	0.00	17.739

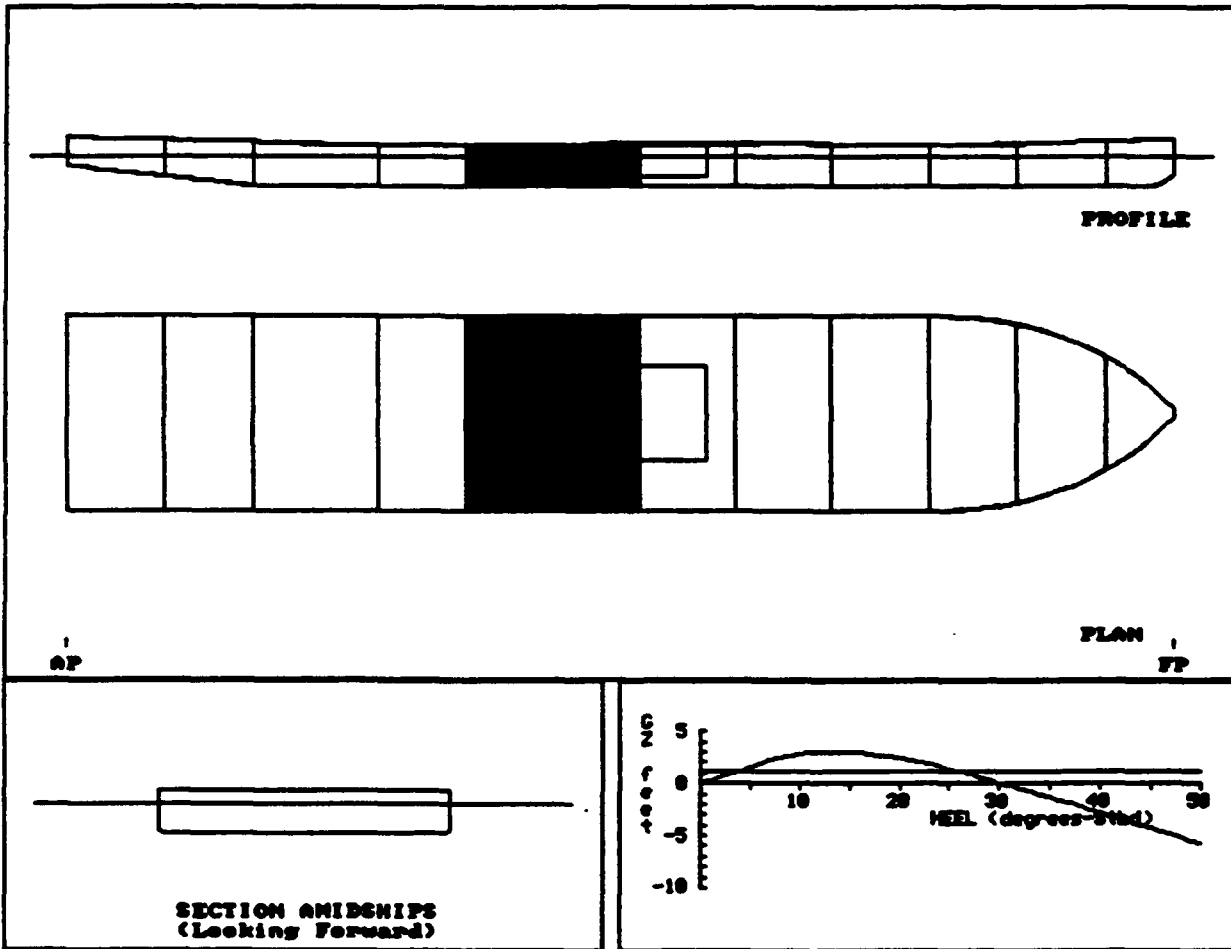

DPRT018A: PUMP 4/STORES 1/SEW
 228' CASINO BOAT

COMPARTMENT FLOODING SUMMARY

At 0.0o Heel	PERM.	FLOODED WTR LTons	% FULL (Damaged)	% FULL (Intact)	SP.VOL. ft3/LT	OUTFLOW LTons
PUMP RM 4	0.85	139.8	FREE	0.0	----	----
STORES1	0.95	269.4	FREE	0.0	----	----
SEWAGE TANK	0.95	85.0	FREE	10.0	35.0063	13.3
Totals		494.2				13.3

INTACT DATA

Draft at AP = 7.850 ft KMT = 45.302 ft LCG = 120.717A ft-FP
 Draft at FP = 7.850 ft VCG = 22.500 ft LCB = 120.717A ft-FP
 Displacement = 2408.5 LTons GMT = 22.802 ft TCG = 0.000 ft-CL

DRAFT/GZ DATA

HEEL degrees	RIGHTING ARM ft	DRAFT AFT ft	DRAFT FWD ft	FLOODED WATER LTons
0.00	0.000	9.403	8.956	494.2
5.00S	1.559	9.424	8.899	493.5
7.00S	2.197	9.438	8.851	492.8
10.00S	2.910	9.511	8.849	489.1
15.00S	3.020	10.044	9.146	484.8
20.00S	2.439	10.919	9.710	480.0
25.00S	1.390	11.937	10.348	474.3
30.00S	0.092	13.041	11.043	470.2
35.00S	-1.322	14.257	11.818	467.1
40.00S	-2.792	15.626	12.700	464.7
50.00S	-5.757	19.101	14.953	461.1

Note: Drafts are measured at A.P. and F.P along ship's centerline

GZ SUMMARY (Evaluated per IMO (SOLAS'90) Rules for Passenger Ships)
 Available Required

Static Heel Angle	0.00 deg	7.00 deg
Angle at Maximum GZ	14.00S deg	
Maximum GZ	3.103 ft	1.160 ft
Range of Positive GZ	30.33 deg	15.00 deg
Gmt (upright damaged)	17.739 ft	
Righting Area (0.00-3.00)	49.018 ft-deg	2.820 ft-deg

DEPT019A: STORES 1.2
 228' CASINO BOAT

Damaged Compartments:
 STORES1 STORES2

	DISPLACEMENT LTons	DRAFT AFT ft	DRAFT FWD ft	TRIM ft	HEEL deg.	UPRIGHT GMT ft
INTACT	2,408.5	7.850	7.850	0.000	0.00	22.802
DAMAGED	2,973.3	10.452	8.229	2.224A	0.00	16.389

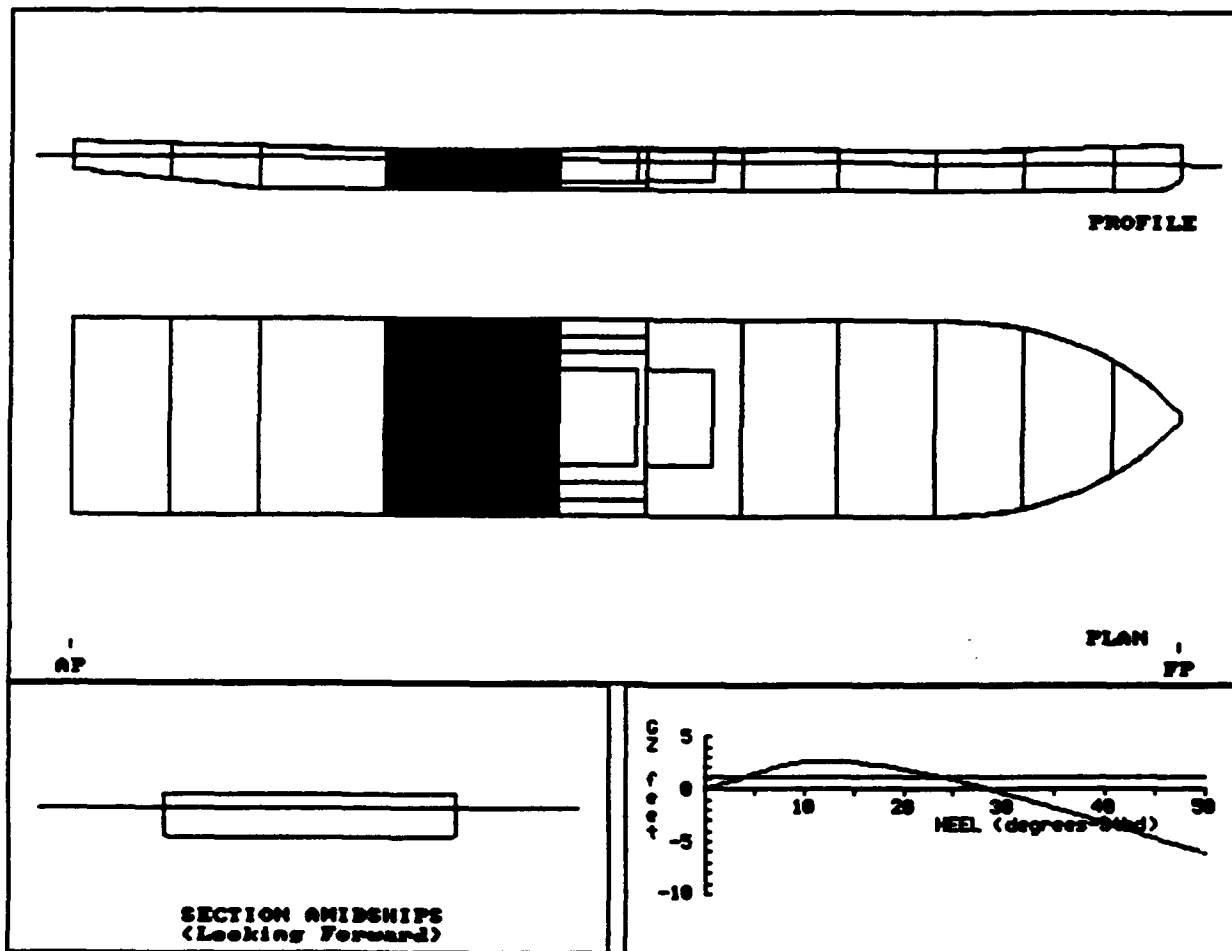

DPRT019A: STORES 1.2
 228' CASINO BOAT

COMPARTMENT FLOODING SUMMARY

At 0.0o Heel	PERM.	FLOODED WTR LTons	% FULL (Damaged)	% FULL (Intact)	SP.VOL. ft3/LT	OUTFLOW LTons
STORES1	0.95	279.4	FREE	0.0	----	----
STORES2	0.95	285.5	FREE	0.0	----	----
Totals		564.8				

INTACT DATA

Draft at AP = 7.850 ft Kmt = 45.302 ft LCG = 120.717A ft-FP
 Draft at FP = 7.850 ft VCG = 22.500 ft LCB = 120.717A ft-FP
 Displacement = 2408.5 LTons GMT = 22.802 ft TCG = 0.000 ft-CL

DRAFT/GZ DATA

HEEL degrees	RIGHTING ARM ft	DRAFT AFT ft	DRAFT FWD ft	FLOODED WATER LTons
0.00	0.000	10.452	8.229	564.8
5.00S	1.441	10.478	8.168	564.5
7.00S	2.019	10.501	8.120	563.8
10.00S	2.587	10.685	8.070	558.2
15.00S	2.550	11.559	8.138	551.1
20.00S	1.910	12.813	8.432	544.6
25.00S	0.873	14.331	8.749	538.4
30.00S	-0.394	16.018	9.075	534.0
35.00S	-1.773	17.889	9.439	530.8
40.00S	-3.202	20.010	9.849	528.4
50.00S	-6.072	25.414	10.876	525.0

Note: Drafts are measured at A.P. and F.P along ship's centerline

GZ SUMMARY (Evaluated per IMO (SOLAS'90) Rules for Passenger Ships)

	Available	Required
Static Heel Angle	0.00 deg	7.00 deg
Angle at Maximum GZ	13.00S deg	
Maximum GZ	2.692 ft	1.160 ft
Range of Positive GZ	28.50 deg	15.00 deg
Gmt (upright damaged)	16.389 ft	
Righting Area (0.00-%.00)	42.057 ft-deg	2.820 ft-deg

DPRT020A: STORES 2/ER
 228' CASINO BOAT

Imaged Compartments:
 STORES2 ENGINE RM

	DISPLACEMENT LTons	DRAFT AFT ft	DRAFT FWD ft	TRIM ft	HEEL deg.	UPRIGHT GMT ft
INTACT	2,408.5	7.850	7.850	0.000	0.00	22.802
DAMAGED	3,147.7	12.555	6.797	5.759A	0.00	15.250

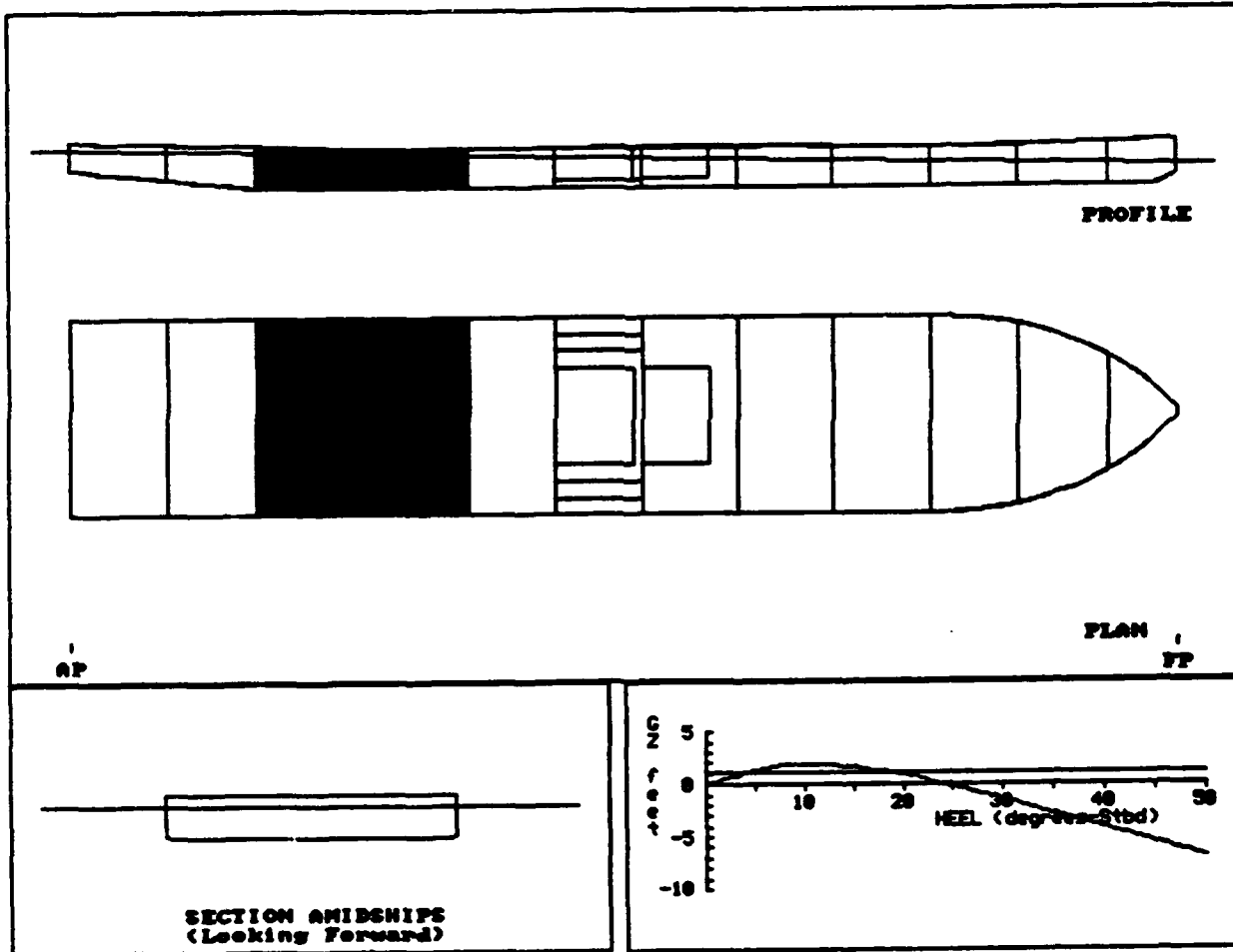

DPRT020A: STORES 2/ER
 228' CASINO BOAT

COMPARTMENT FLOODING SUMMARY

At 0.0o Heel	PERM.	FLOODED WTR LTons	% FULL (Damaged)	% FULL (Intact)	SP.VOL. ft3/LT	OUTFLOW LTons
STORES2	0.95	313.9	FREE	0.0	----	----
ENGINE RM	0.85	425.4	FREE	0.0	----	----
Totals		739.2				

INTACT DATA

Draft at AP = 7.850 ft KMT = 45.302 ft LCG = 120.717A ft-FP
 Draft at FP = 7.850 ft VCG = 22.500 ft LCB = 120.717A ft-FP
 Displacement = 2408.5 LTons GMT = 22.802 ft TCG = 0.000 ft-CL

DRAFT/GZ DATA

HEEL degrees	RIGHTING ARM ft	DRAFT AFT ft	DRAFT FWD ft	FLOODED WATER LTons
0.00	0.000	12.555	6.797	739.2
5.00S	1.315	12.619	6.713	737.9
7.00S	1.698	12.787	6.624	732.6
10.00S	1.946	13.419	6.363	728.2
15.00S	1.685	14.957	6.095	724.3
20.00S	0.907	17.034	5.876	723.9
25.00S	-0.170	19.479	5.637	723.0
30.00S	-1.421	22.266	5.336	721.0
35.00S	-2.760	25.415	4.979	718.5
40.00S	-4.131	29.012	4.564	716.2
50.00S	-6.849	38.109	3.566	712.4

Note: Drafts are measured at A.P. and F.P. along ship's centerline

GZ SUMMARY (Evaluated per IMO (SOLAS'90) Rules for Passenger Ships)

	Available	Required
Static Heel Angle	0.00 deg	7.00 deg
Angle at Maximum GZ	12.00S deg	
Maximum GZ	1.952 ft	1.160 ft
Range of Positive GZ	24.27 deg	15.00 deg
Gmt (upright damaged)	15.250 ft	
Righting Area (0.00-%.00)	29.356 ft-deg	2.820 ft-deg

DPR021A: ER/PUMP 5
 228' CASINO BOAT

Imaged Compartments:
 ENGINE RN PUMP RN 5

	DISPLACEMENT LTons	DRAFT AFT ft	DRAFT FWD ft	TRIM ft	HEEL deg.	UPRIGHT Gmt ft
INTACT	2,408.5	7.850	7.850	0.000	0.00	22.802
DAMAGED	3,123.7	13.445	5.573	7.872A	0.00	15.132

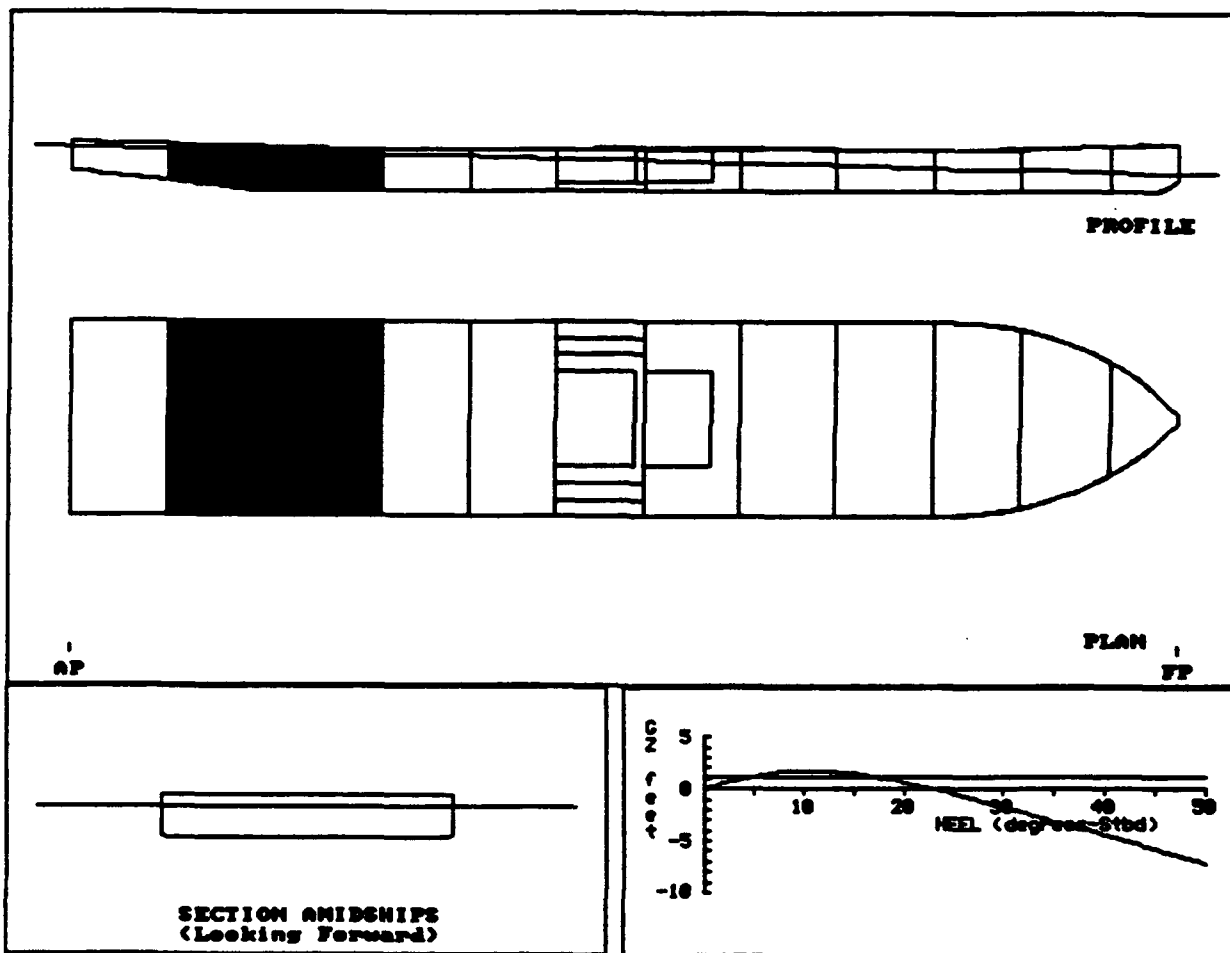

DPRT021A: ER/PUMP 5
 228' CASINO BOAT

COMPARTMENT FLOODING SUMMARY

At 0.0o Heel	PERM.	FLOODED WTR LTons	% FULL (Damaged)	% FULL (Intact)	SP.VOL. ft ³ /LT	OUTFLOW LTons
ENGINE RM	0.85	441.1	FREE	0.0	----	----
PUMP RM 5	0.85	274.0	FREE	0.0	----	----
Totals		715.2				

INTACT DATA

Draft at AP = 7.850 ft Kmt = 45.302 ft LCG = 120.717A ft-FP
 Draft at FP = 7.850 ft VCG = 22.500 ft LCB = 120.717A ft-FP
 Displacement = 2408.5 LTons Gmt = 22.802 ft TCG = 0.000 ft-CL

DRAFT/GZ DATA

HEEL degrees	RIGHTING ARM ft	DRAFT AFT ft	DRAFT FWD ft	FLOODED WATER LTons
0.00	0.000	13.445	5.573	715.2
5.00S	1.233	13.608	5.443	712.1
7.00S	1.547	13.939	5.261	708.5
10.00S	1.753	14.736	4.922	706.1
15.00S	1.487	16.714	4.299	709.0
20.00S	0.682	19.252	3.651	714.6
25.00S	-0.428	22.268	2.887	720.7
30.00S	-1.695	25.719	2.008	725.9
35.00S	-3.044	29.617	1.004	729.8
40.00S	-4.419	34.076	-0.157	732.6
50.00S	-7.132	45.406	-3.067	735.3

Note: Drafts are measured at A.P. and F.P along ship's centerline

GZ SUMMARY (Evaluated per IMO (SOLAS'90) Rules for Passenger Ships)

	Available	Required
Static Heel Angle	0.00 deg	7.00 deg
Angle at Maximum GZ	12.00S deg	
Maximum GZ	1.755 ft	1.160 ft
Range of Positive GZ	23.18 deg	15.00 deg
Gmt (upright damaged)	15.132 ft	
Righting Area (0.00-7.00)	25.954 ft-deg	2.820 ft-deg

DPR022A: PUMP5/STEER
 228' CASINO BOAT

Imaged Compartments:
 STEER/VOID PUMP RM 5

	DISPLACEMENT LTons	DRAFT AFT ft	DRAFT FWD ft	TRIM ft	HEEL deg.	UPRIGHT GMT ft
INTACT	2,408.5	7.850	7.850	0.000	0.00	22.802
DAMAGED	2,885.2	12.464	5.260	7.203A	0.00	15.006

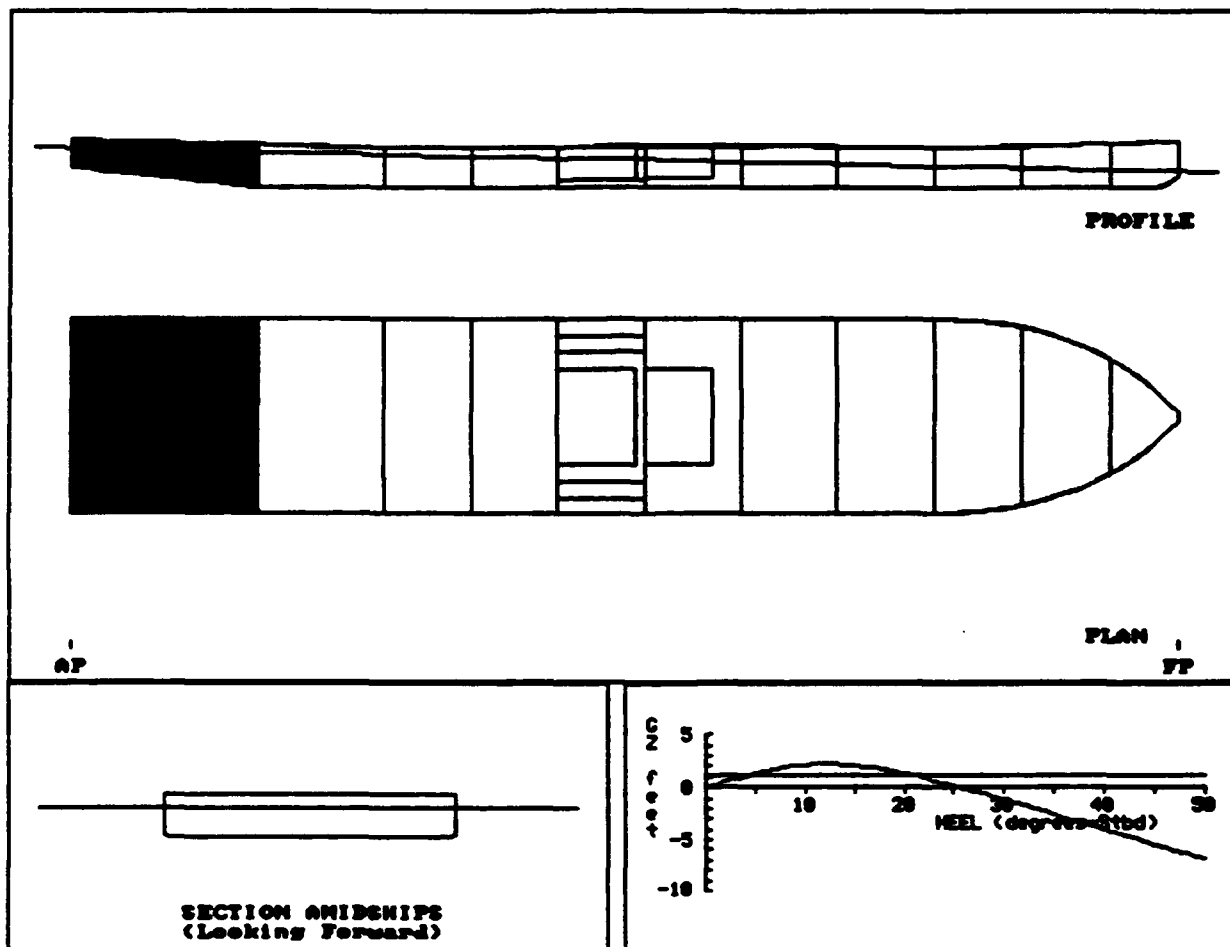

DPRT022A: PUMPS/STEER
 228' CASINO BOAT

COMPARTMENT FLOODING SUMMARY

At 0.0o Heel	PERM.	FLOODED WTR LTons	% FULL (Damaged)	% FULL (Intact)	SP.VOL. ft3/LT	OUTFLOW LTons
STEER/VOID	0.95	226.1	FREE	0.0	----	----
PUMP RM 5	0.85	250.6	FREE	0.0	----	----
Totals		476.7				

INTACT DATA

Draft at AP = 7.850 ft	KMt = 45.302 ft	LCG = 120.717A ft-FP
Draft at FP = 7.850 ft	VCG = 22.500 ft	LCB = 120.717A ft-FP
Displacement = 2408.5 LTons	GMT = 22.802 ft	TCG = 0.000 ft-CL

DRAFT/GZ DATA

HEEL degrees	RIGHTING ARM ft	DRAFT AFT ft	DRAFT FWD ft	FLOODED WATER LTons
0.00	0.000	12.464	5.260	476.7
5.00S	1.307	12.534	5.175	479.6
7.00S	1.746	12.673	5.086	478.9
10.00S	2.131	13.300	4.754	483.6
15.00S	2.072	15.110	4.018	498.3
20.00S	1.314	17.594	3.131	514.8
25.00S	0.182	20.584	2.067	529.8
30.00S	-1.144	23.996	0.839	542.1
35.00S	-2.561	27.884	-0.572	552.2
40.00S	-4.015	32.350	-2.205	560.7
50.00S	-6.898	43.831	-6.476	574.0

Note: Drafts are measured at A.P. and F.P along ship's centerline

GZ SUMMARY (Evaluated per IMO (SOLAS'90) Rules for Passenger Ships)

	Available	Required
Static Heel Angle	0.00 deg	7.00 deg
Angle at Maximum GZ	13.00S deg	
Maximum GZ	2.206 ft	1.160 ft
Range of Positive GZ	25.72 deg	15.00 deg
Gmt (upright damaged)	15.006 ft	
Righting Area (0.00-%.00)	33.997 ft-deg	2.820 ft-deg

RTRN001B: FPK/VOID1
 228' CASINO BOAT

Managed Compartments:

FOREPEAK THRUST/VOID

	DISPLACEMENT LTons	DRAFT AFT ft	DRAFT FWD ft	TRIM ft	HEEL deg.	UPRIGHT GMT ft
INTACT	2,348.2	7.680	7.680	0.000	0.00	23.692
DAMAGED	2,487.7	6.908	9.453	2.545F	0.00	22.860

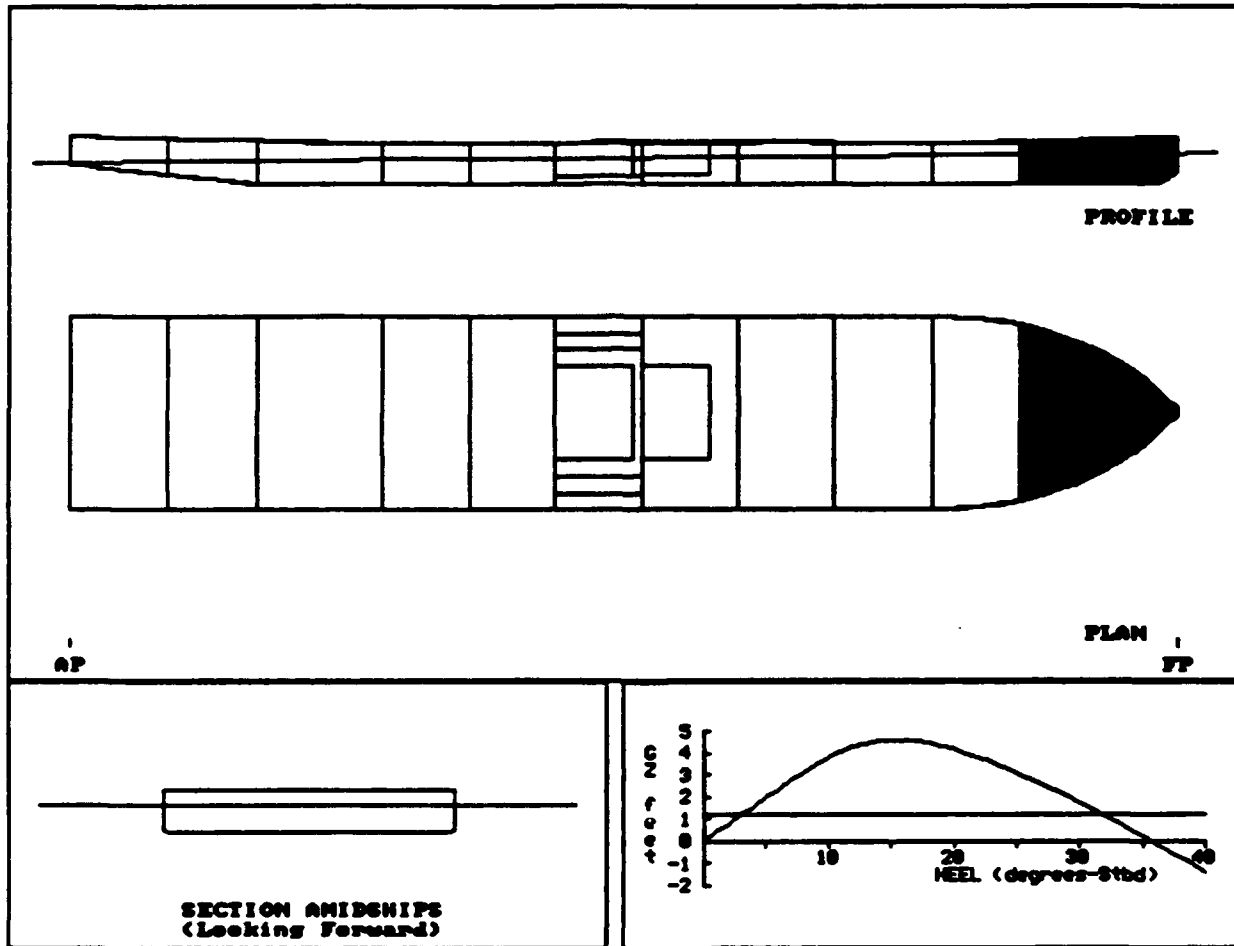

RTRN001B: FPK/VOID1
 228' CASINO BOAT

COMPARTMENT FLOODING SUMMARY

At 0.0o Heel	PERM.	FLOODED WTR LTons	% FULL (Damaged)	% FULL (Intact)	SP.VOL. ft3/LT	OUTFLOW LTons
FOREPEAK	0.95	27.1	FREE	0.0	----	----
THRUST/VOID	0.95	112.4	FREE	0.0	----	----
Totals		139.6				

INTACT DATA

Draft at AP = 7.680 ft	KMT = 46.192 ft	LCG = 120.627A ft-FP
Draft at FP = 7.680 ft	VCG = 22.500 ft	LCB = 120.627A ft-FP
Displacement = 2348.2 LTons	GMT = 23.692 ft	TCG = 0.000 ft-CL

DRAFT/GZ DATA

HEEL degrees	RIGHTING ARM ft	DRAFT AFT ft	DRAFT FWD ft	FLOODED WATER LTons
0.00	0.000	6.908	9.453	139.6
5.00S	1.972	6.865	9.455	141.0
7.00S	2.746	6.814	9.464	142.6
10.00S	3.820	6.669	9.563	147.6
15.00S	4.608	6.233	10.494	167.3
20.00S	4.207	5.667	12.013	187.1
25.00S	3.123	5.012	13.746	200.8
27.00S	2.595	4.722	14.500	205.0
30.00S	1.745	4.269	15.685	210.2
35.00S	0.225	3.430	17.861	216.8
40.00S	-1.362	2.449	20.369	221.7

Note: Drafts are measured at A.P. and F.P along ship's centerline

GZ SUMMARY (Evaluated per IMO (SOLAS'90) Rules for Passenger Ships)

	Available	Required
Static Heel Angle	0.00 deg	7.00 deg
Angle at Maximum GZ	17.00S deg	
Maximum GZ	4.608 ft	1.180 ft
Range of Positive GZ	35.72 deg	15.00 deg
Gmt (upright damaged)	22.860 ft	
Righting Area (0.00-3.00)	71.654 ft-deg	2.820 ft-deg

RTRN002B: THRUST/TRANS
 228' CASINO BOAT

Imaged Compartments:
 THRUST/VOID TRANSFORMERS

	DISPLACEMENT LTons	DRAFT AFT ft	DRAFT FWD ft	TRIM ft	HEEL deg.	UPRIGHT GMT ft
INTACT	2,348.2	7.680	7.680	0.000	0.00	23.692
DAMAGED	2,737.7	5.957	12.037	6.080F	0.00	20.185

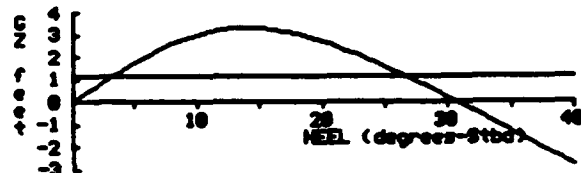
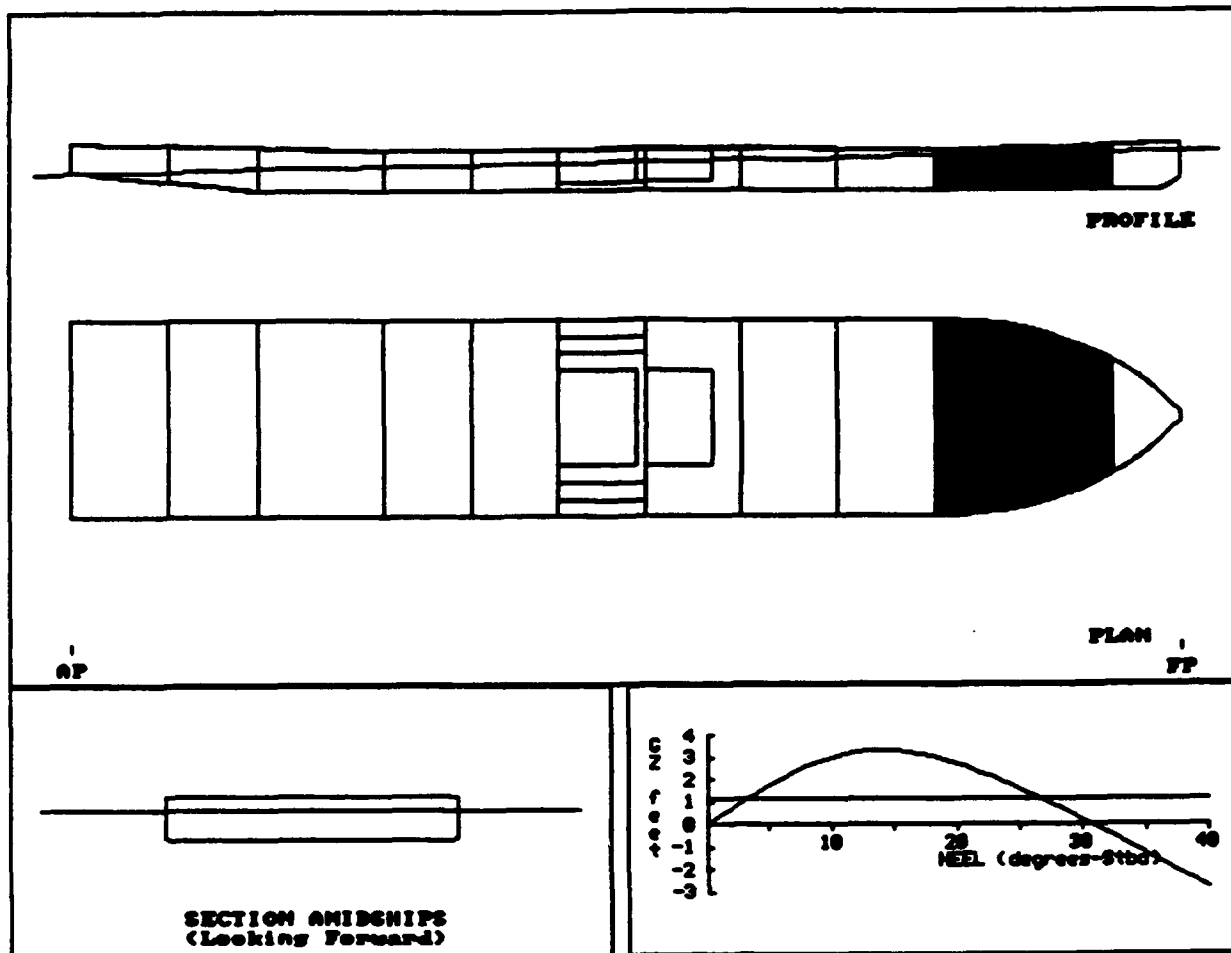

RTRN002B: THRUST/TRANS
 228' CASINO BOAT

COMPARTMENT FLOODING SUMMARY

At 0.0o Heel	PERM.	FLOODED WTR LTons	% FULL (Damaged)	% FULL (Intact)	SP.VOL. ft3/LT	OUTFLOW LTons
THRUST/VOID	0.95	156.3	FREE	0.0	----	----
TRANSFORMERS	0.95	233.3	FREE	0.0	----	----
Totals		389.6				

INTACT DATA

Draft at AP = 7.680 ft	KMT = 46.192 ft	LCG = 120.627A ft-FP
Draft at FP = 7.680 ft	VCG = 22.500 ft	LCB = 120.627A ft-FP
Displacement = 2348.2 LTons	GMT = 23.692 ft	TCG = 0.000 ft-CL

DRAFT/GZ DATA

HEEL degrees	RIGHTING ARM ft	DRAFT AFT ft	DRAFT FWD ft	FLOODED WATER LTons
0.00	0.000	5.957	12.037	389.6
5.00S	1.742	5.843	12.114	394.5
7.00S	2.362	5.730	12.241	395.1
10.00S	3.026	5.428	12.757	398.7
15.00S	3.311	4.739	14.438	411.4
20.00S	2.727	3.722	17.057	427.8
25.00S	1.623	2.498	20.217	441.0
27.00S	1.089	1.918	21.682	445.9
30.00S	0.240	0.960	24.045	452.4
35.00S	-1.243	-0.740	28.308	460.2
40.00S	-2.783	-2.789	33.292	466.3

Note: Drafts are measured at A.P. and F.P along ship's centerline

GZ SUMMARY (Evaluated per IMO (SOLAS'90) Rules for Passenger Ships)

	Available	Required
Static Heel Angle	0.00 deg	7.00 deg
Angle at Maximum GZ	15.00S deg	
Maximum GZ	3.332 ft	1.180 ft
Range of Positive GZ	30.83 deg	15.00 deg
Gmt (upright damaged)	20.185 ft	
Righting Area (0.00-3.00)	53.360 ft-deg	2.820 ft-deg

RTRN003B: TRANS/PUMP RM1
 228' CASINO BOAT

Imaged Compartments:
 TRANSFORMERS PUMP RM 1

	DISPLACEMENT LTons	DRAFT AFT ft	DRAFT FWD ft	TRIM ft	HEEL deg.	UPRIGHT GMT ft
INTACT	2,348.2	7.680	7.680	0.000	0.00	23.692
DAMAGED	2,938.1	5.936	13.236	7.299F	0.00	18.347

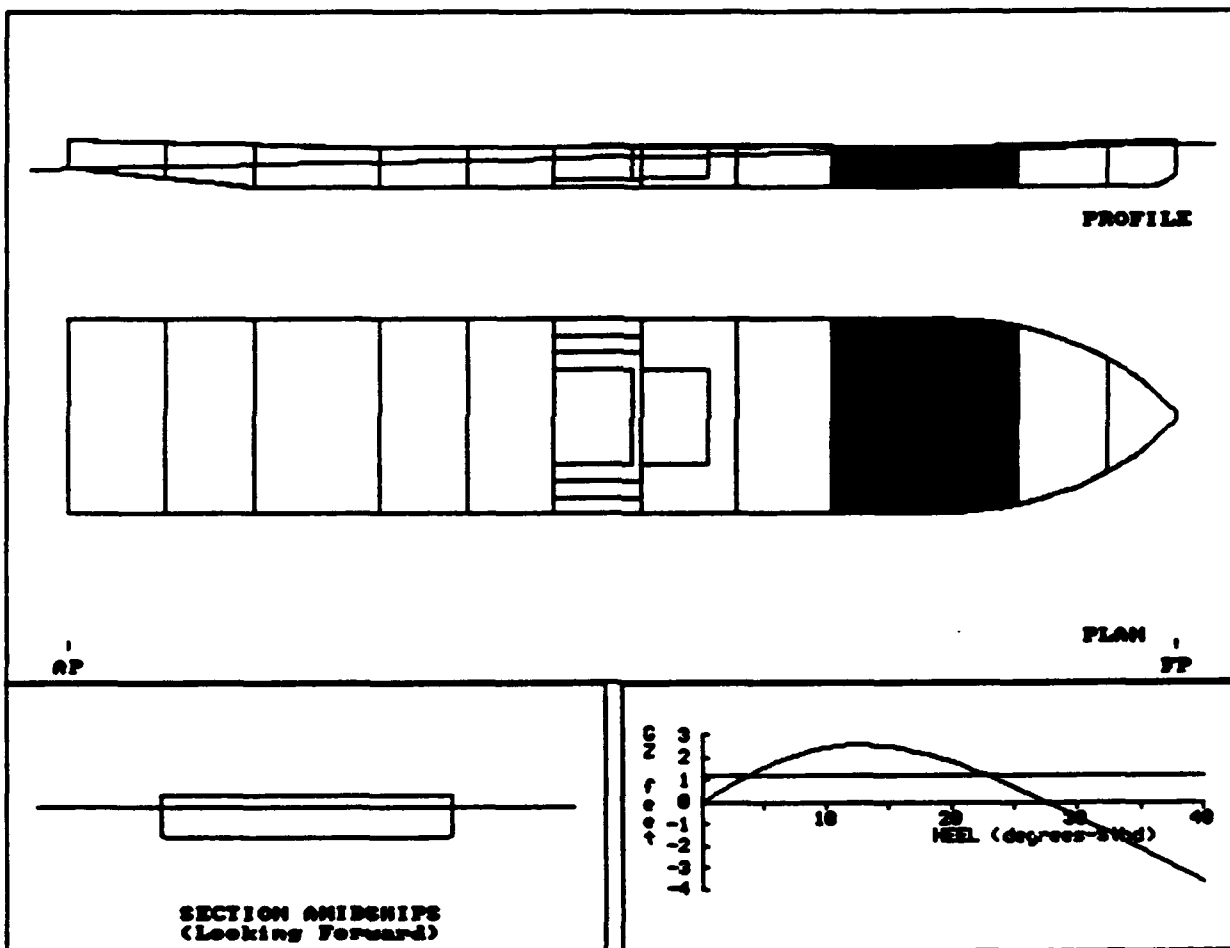

RTRN003B: TRANS/PUMP RM1
 228' CASINO BOAT

COMPARTMENT FLOODING SUMMARY

At 0.0o Heel	PERM.	FLOODED WTR LTons	% FULL (Damaged)	% FULL (Intact)	SP.VOL. ft3/LT	OUTFLOW LTons
TRANSFORMERS	0.95	260.2	FREE	0.0	----	----
PUMP RM 1	0.95	329.7	FREE	0.0	----	----
Totals		589.9				

INTACT DATA

Draft at AP = 7.680 ft Kmt = 46.192 ft LCG = 120.627A ft-FP
 Draft at FP = 7.680 ft VCG = 22.500 ft LCB = 120.627A ft-FP
 Displacement = 2348.2 LTons Gmt = 23.692 ft TCG = 0.000 ft-CL

DRAFT/GZ DATA

HEEL degrees	RIGHTING ARM ft	DRAFT AFT ft	DRAFT FWD ft	FLOODED WATER LTons
0.00	0.000	5.936	13.236	589.9
5.00S	1.536	5.821	13.346	585.7
7.00S	2.014	5.678	13.588	580.7
10.00S	2.461	5.333	14.322	578.1
15.00S	2.485	4.592	16.414	583.8
20.00S	1.814	3.571	19.490	596.1
25.00S	0.692	2.294	23.305	608.7
27.00S	0.167	1.689	25.049	613.6
30.00S	-0.665	0.702	27.881	620.5
35.00S	-2.121	-1.184	33.263	631.0
40.00S	-3.619	-3.501	39.661	640.2

Note: Drafts are measured at A.P. and F.P along ship's centerline

GZ SUMMARY (Evaluated per IMO (SOLAS'90) Rules for Passenger Ships)

	Available	Required
Static Heel Angle	0.00 deg	7.00 deg
Angle at Maximum GZ	14.00S deg	
Maximum GZ	2.574 ft	1.180 ft
Range of Positive GZ	27.61 deg	15.00 deg
Gmt (upright damaged)	18.347 ft	
Righting Area (0.00-7.00)	41.201 ft-deg	2.820 ft-deg

RTRN004B: PUMP RMS 1,2
 228' CASINO BOAT

Used Compartments:
 PUMP RM 1 PUMP RM 2

	DISPLACEMENT LTons	DRAFT AFT ft	DRAFT FWD ft	TRIM ft	HEEL deg.	UPRIGHT Gmt ft
INTACT	2,348.2	7.680	7.680	0.000	0.00	23.692
DAMAGED	3,014.7	6.721	12.807	6.086F	0.00	18.268

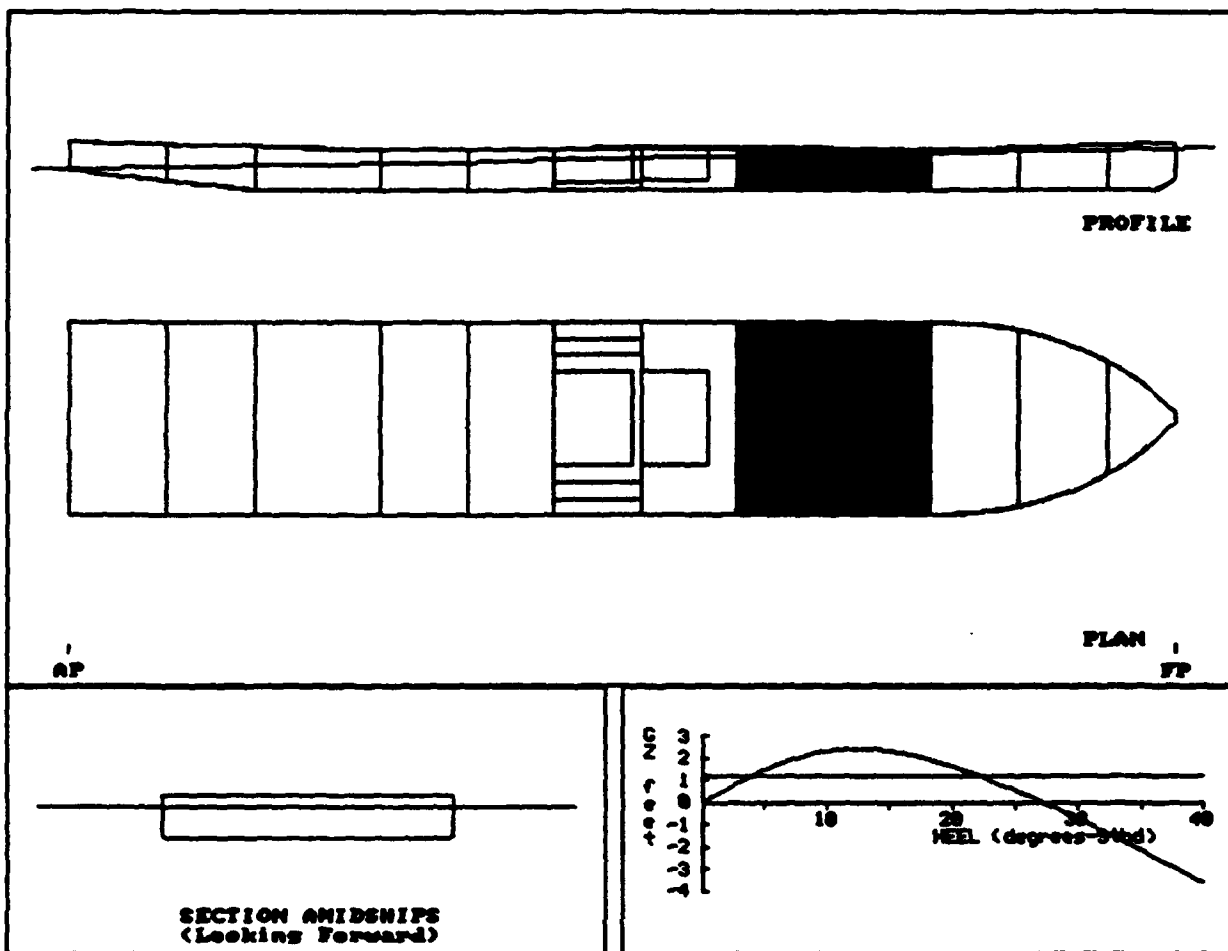

RTRN005B: PUMP RMS 2,3
 228' CASINO BOAT

Imaged Compartments:
 PUMP RM 2 PUMP RM 3

	DISPLACEMENT LTons	DRAFT AFT ft	DRAFT FWD ft	TRIM ft	HEEL deg	UPRIGHT GMT ft
INTACT	2,348.2	7.680	7.680	0.000	0.00	23.692
DAMAGED	2,873.3	7.640	10.918	3.278F	0.00	17.950

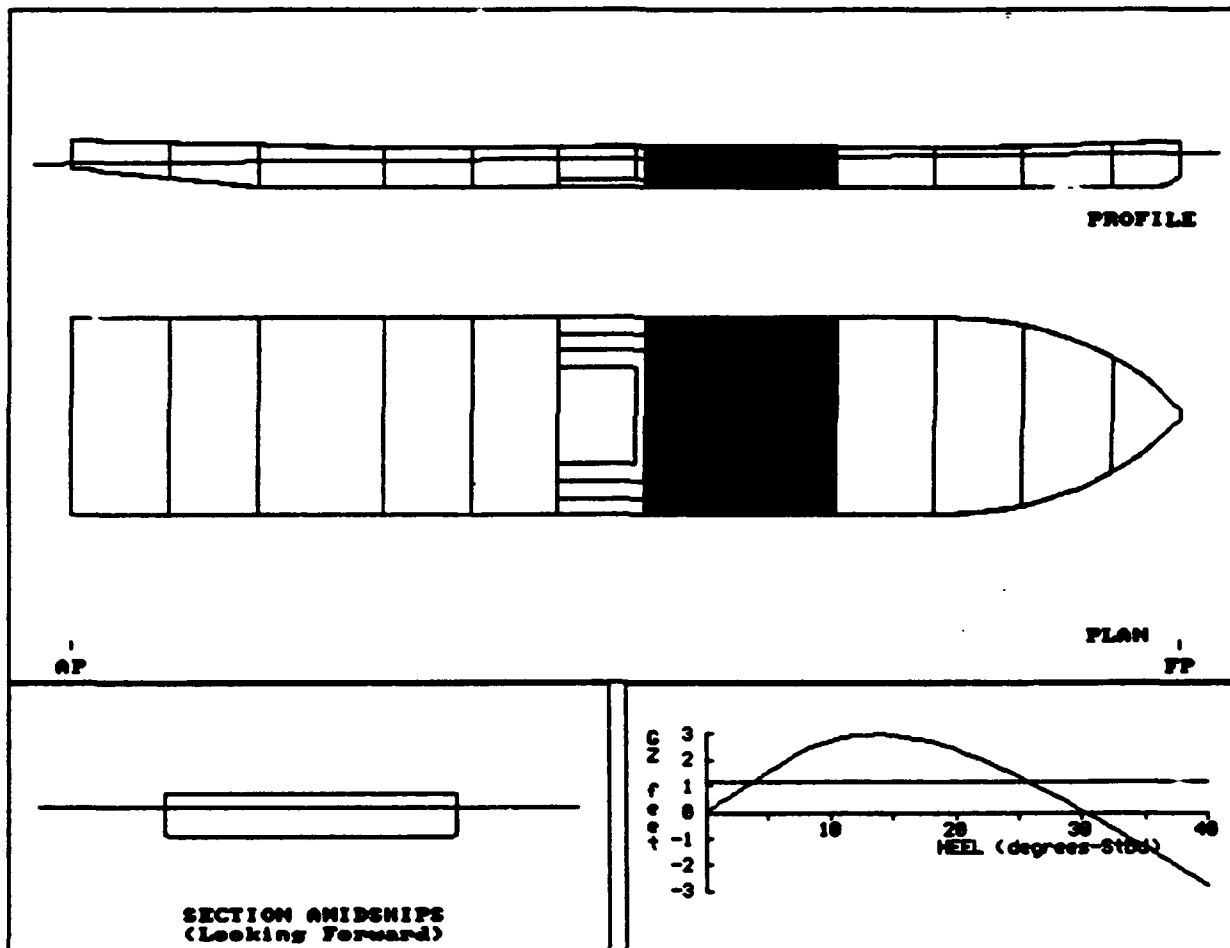

RTRN006B: PUMP 2,3/H2O TANK
 228' CASINO BOAT

Imaged Compartments:

PUMP RM 2 PUMP RM 3 WATER TANK

	DISPLACEMENT LTons	DRAFT AFT ft	DRAFT FWD ft	TRIM ft	HEEL deg.	UPRIGHT GMT ft
INTACT	2,348.2	7.680	7.680	0.000	0.00	23.692
DAMAGED	2,950.1	7.717	11.287	3.570F	0.00	17.941

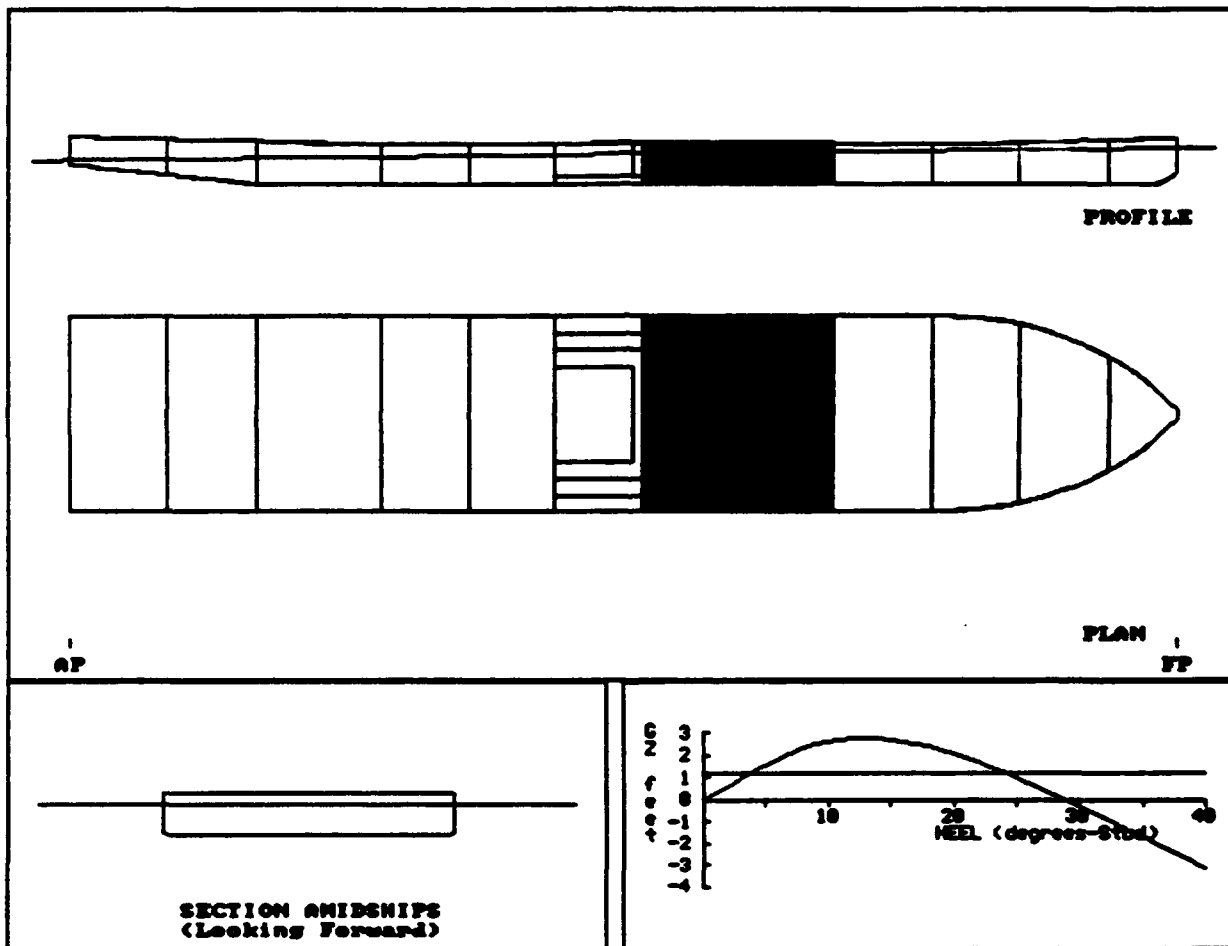

RTRN006B: PUMP 2,3/H2O TMR
 228' CASINO BOAT

COMPARTMENT FLOODING SUMMARY

At 0.0o Heel	PERM.	FLOODED WTR LTons	% FULL (Damaged)	% FULL (Intact)	SP.VOL. ft3/LT	OUTFLOW LTons
PUMP RM 2	0.95	319.6	FREE	0.0	----	----
PUMP RM 3	0.85	218.9	FREE	0.0	----	----
WATER TANK	0.95	74.1	FREE	10.0	35.8800	10.8
Totals		612.7				10.8

INTACT DATA

Draft at AP = 7.680 ft Kmt = 46.192 ft LCG = 120.627A ft-FP
 Draft at FP = 7.680 ft VCG = 22.500 ft LCB = 120.627A ft-FP
 Displacement = 2348.2 LTons GMT = 23.692 ft TCG = 0.000 ft-CL

DRAFT/GZ DATA

HEEL degrees	RIGHTING ARM ft	DRAFT AFT ft	DRAFT FWD ft	FLOODED WATER LTons
0.00	0.000	7.717	11.287	612.7
5.00S	1.567	7.729	11.227	610.9
7.00S	2.114	7.697	11.262	610.0
10.00S	2.635	7.602	11.547	604.6
15.00S	2.705	7.524	12.545	595.9
20.00S	2.095	7.654	13.914	587.8
25.00S	1.031	7.775	15.587	580.2
27.00S	0.532	7.834	16.300	577.8
30.00S	-0.268	7.854	17.519	575.4
35.00S	-1.676	7.919	19.709	572.3
40.00S	-3.133	7.971	22.226	570.2

Note: Drafts are measured at A.P. and F.P along ship's centerline

GZ SUMMARY (Evaluated per IMO (SOLAS'90) Rules for Passenger Ships)

	Available	Required
Static Heel Angle	0.00 deg	7.00 deg
Angle at Maximum GZ	14.00S deg	
Maximum GZ	2.779 ft	1.180 ft
Range of Positive GZ	29.02 deg	15.00 deg
Gmt (upright damaged)	17.941 ft	
Righting Area (0.00-1.00)	44.587 ft-deg	2.820 ft-deg

RTRN008B: PUMP 3,4/H2O
 228' CASINO BOAT

Imaged Compartments:

PUMP RN 3 WATER TANK PUMP RN 4

	DISPLACEMENT LTons	DRAFT AFT ft	DRAFT FWD ft	TRIM ft	HEEL deg.	UPRIGHT GMT ft
INTACT	2,348.2	7.680	7.680	0.000	0.00	23.692
DAMAGED	2,741.0	8.226	9.440	1.215F	0.00	18.892

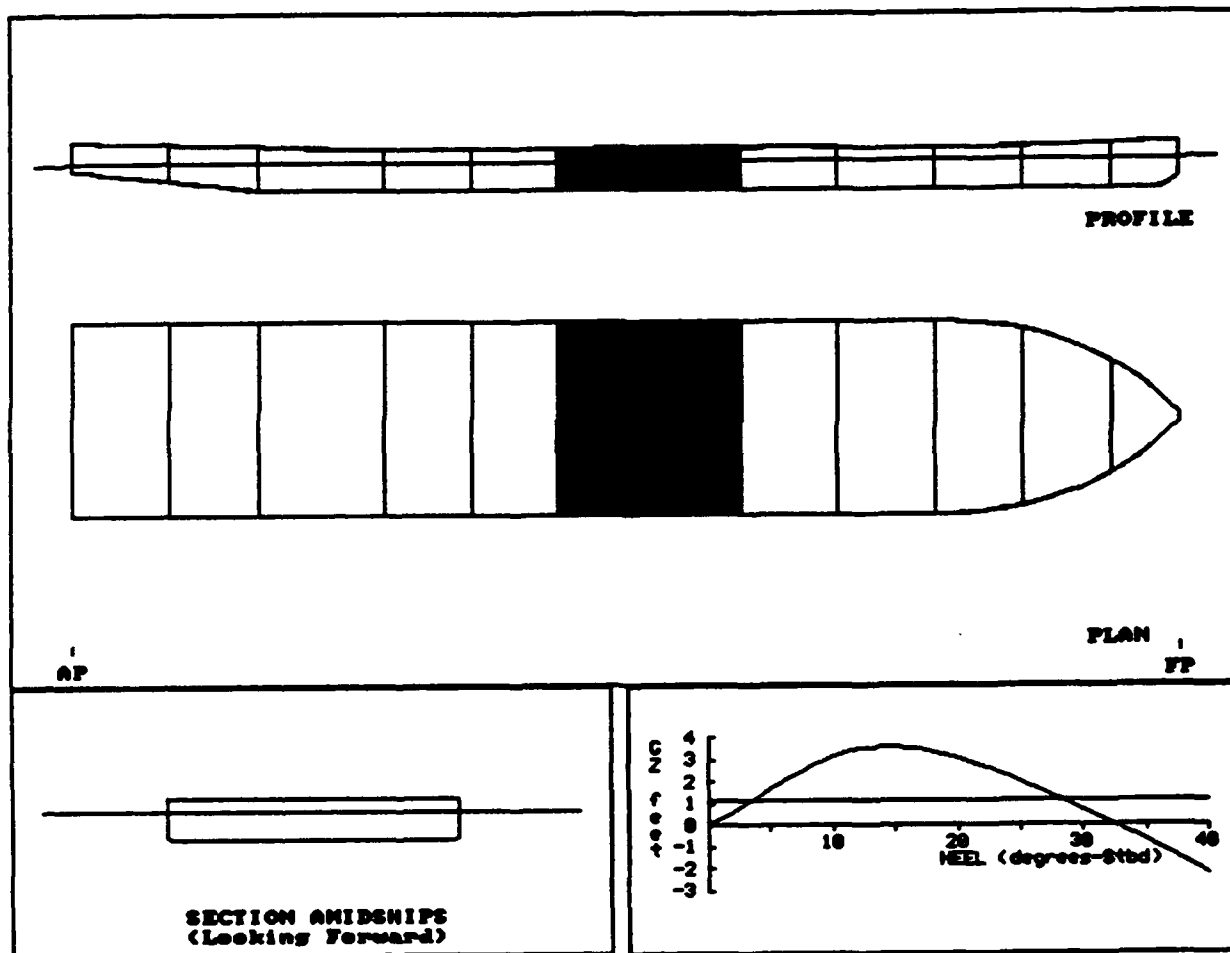

RTRN008B: PUMP 3,4/H2O
 228' CASINO BOAT

COMPARTMENT FLOODING SUMMARY

At 0.0o Heel	PERM.	FLOODED WTR LTons	% FULL (Damaged)	% FULL (Intact)	SP.VOL. ft3/LT	OUTFLOW LTons
PUMP RM 3	0.85	202.6	FREE	0.0	----	----
WATER TANK	0.95	65.4	FREE	10.0	35.8800	10.8
PUMP RM 4	0.85	135.5	FREE	0.0	----	----
Totals		403.6				10.8

INTACT DATA

Draft at AP = 7.680 ft	KMt = 46.192 ft	LCG = 120.627A ft-FP
Draft at FP = 7.680 ft	VCG = 22.500 ft	LCB = 120.627A ft-FP
Displacement = 2348.2 LTons	GMT = 23.692 ft	TCG = 0.000 ft-CL

DRAFT/GZ DATA

HEEL degrees	RIGHTING ARM ft	DRAFT AFT ft	DRAFT FWD ft	FLOODED WATER LTons
0.00	0.000	8.226	9.440	403.6
5.00S	1.658	8.243	9.386	402.7
7.00S	2.323	8.244	9.343	401.8
10.00S	3.166	8.215	9.359	398.3
15.00S	3.568	8.288	9.846	388.6
20.00S	3.104	8.637	10.557	376.2
25.00S	2.056	8.987	11.405	367.5
27.00S	1.550	9.114	11.793	365.2
30.00S	0.743	9.361	12.344	362.2
35.00S	-0.698	9.765	13.404	358.6
40.00S	-2.200	10.216	14.618	355.9

Note: Drafts are measured at A.P. and F.P along ship's centerline

GZ SUMMARY (Evaluated per IMO (SOLAS'90) Rules for Passenger Ships)

	Available	Required
Static Heel Angle	0.00 deg	7.00 deg
Angle at Maximum GZ	15.00S deg	
Maximum GZ	3.574 ft	1.180 ft
Range of Positive GZ	32.62 deg	15.00 deg
Gmt (upright damaged)	18.892 ft	
Righting Area (0.00-7.00)	56.538 ft-deg	2.820 ft-deg

RTRN009B: PUMP 3,4/SEW
 228' CASINO BOAT

Imaged Compartments:

PUMP RM 3 PUMP RM 4 SEWAGE TANK

	DISPLACEMENT LTons	DRAFT AFT ft	DRAFT FWD ft	TRIM ft	HEEL deg.	UPRIGHT Gmt ft
INTACT	2,348.2	7.680	7.680	0.000	0.00	23.692
DAMAGED	2,617.8	8.004	8.953	0.949F	0.00	19.647

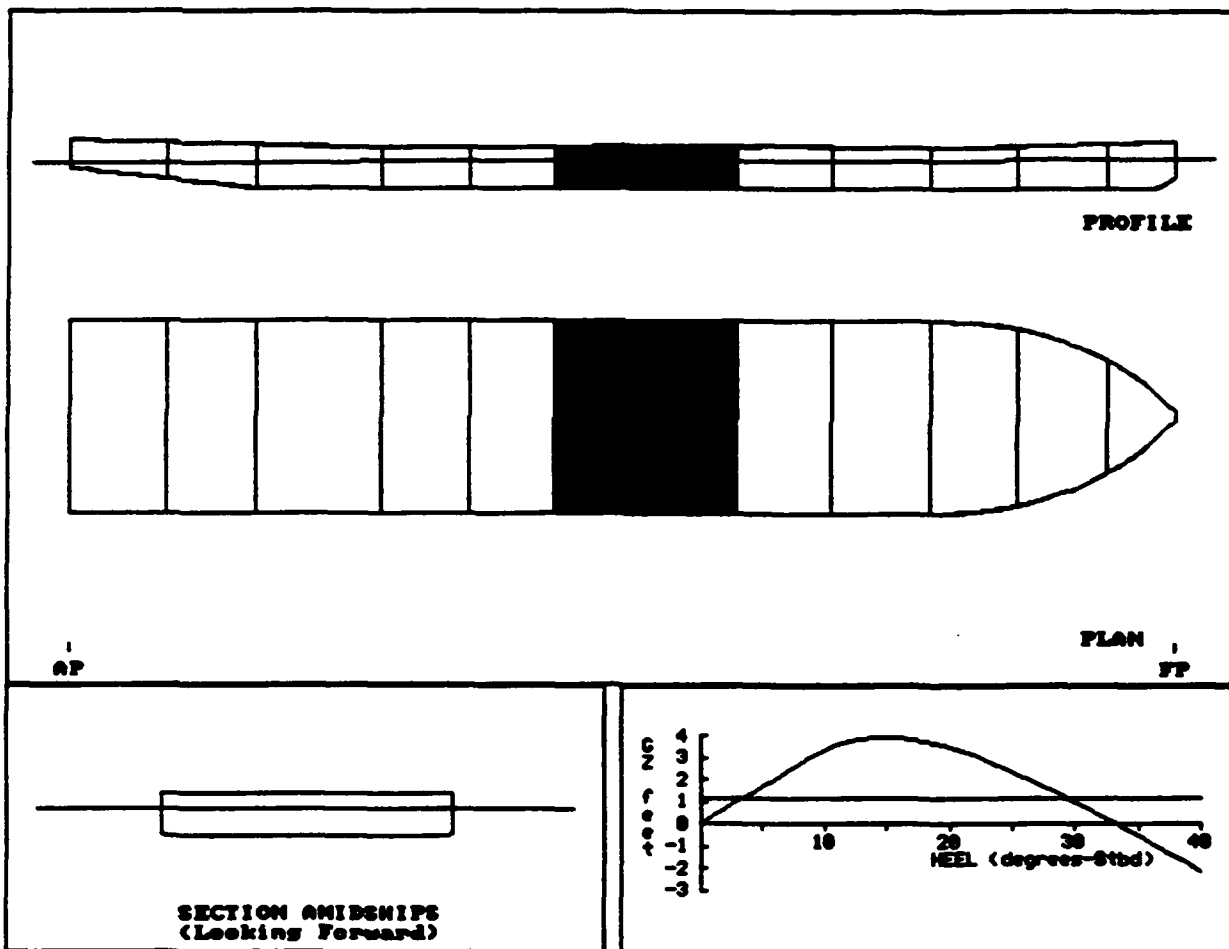

RTRM009B: PUMP 3,4/SEW
 228' CASINO BOAT

COMPARTMENT FLOODING SUMMARY

At 0.0o Heel	PERM.	FLOODED WTR LTons	% FULL (Damaged)	% FULL (Intact)	SP.VOL. ft ³ /LT	OUTFLOW LTons
PUMP RM 3	0.85	195.3	FREE	0.0	----	----
PUMP RM 4	0.85	131.6	FREE	0.0	----	----
SEWAGE TANK	0.95	75.6	FREE	100.0	35.0063	132.9
Totals		402.5				132.9

INTACT DATA

Draft at AP = 7.680 ft KMT = 46.192 ft LCG = 120.627A ft-FP
 Draft at FP = 7.680 ft VCG = 22.500 ft LCB = 120.627A ft-FP
 Displacement = 2348.2 LTons GMT = 23.692 ft TCG = 0.000 ft-CL

DRAFT/GZ DATA

HEEL degrees	RIGHTING ARM ft	DRAFT AFT ft	DRAFT FWD ft	FLOODED WATER LTons
0.00	0.000	8.004	8.953	402.5
5.00S	1.722	8.018	8.901	401.7
7.00S	2.408	8.012	8.863	400.7
10.00S	3.363	7.968	8.836	397.7
15.00S	3.961	7.971	9.215	387.8
20.00S	3.506	8.200	9.788	375.2
25.00S	2.396	8.424	10.448	367.4
27.00S	1.860	8.502	10.750	365.1
30.00S	1.000	8.636	11.209	362.2
35.00S	-0.526	8.915	11.999	358.4
40.00S	-2.120	9.203	12.932	355.4

Note: Drafts are measured at A.P. and F.P along ship's centerline

GZ SUMMARY (Evaluated per IMO (SOLAS'90) Rules for Passenger Ships)

	Available	Required
Static Heel Angle	0.00 deg	7.00 deg
Angle at Maximum GZ	16.00S deg	
Maximum GZ	3.961 ft	1.180 ft
Range of Positive GZ	33.31 deg	15.00 deg
Gmt (upright damaged)	19.647 ft	
Righting Area (0.00-3.00)	61.615 ft-deg	2.820 ft-deg

RTRM010B: PUMP 3,4/SEW/H2O
 228' CASINO BOAT

Imaged Compartments:

PUMP RM 3 WATER TANK PUMP RM 4 SEWAGE TANK

	DISPLACEMENT LTons	DRAFT AFT ft	DRAFT FWD ft	TRIM ft	HEEL deg.	UPRIGHT GMT ft
INTACT	2,348.2	7.680	7.680	0.000	0.00	23.692
DAMAGED	2,678.3	8.077	9.235	1.158F	0.00	19.568

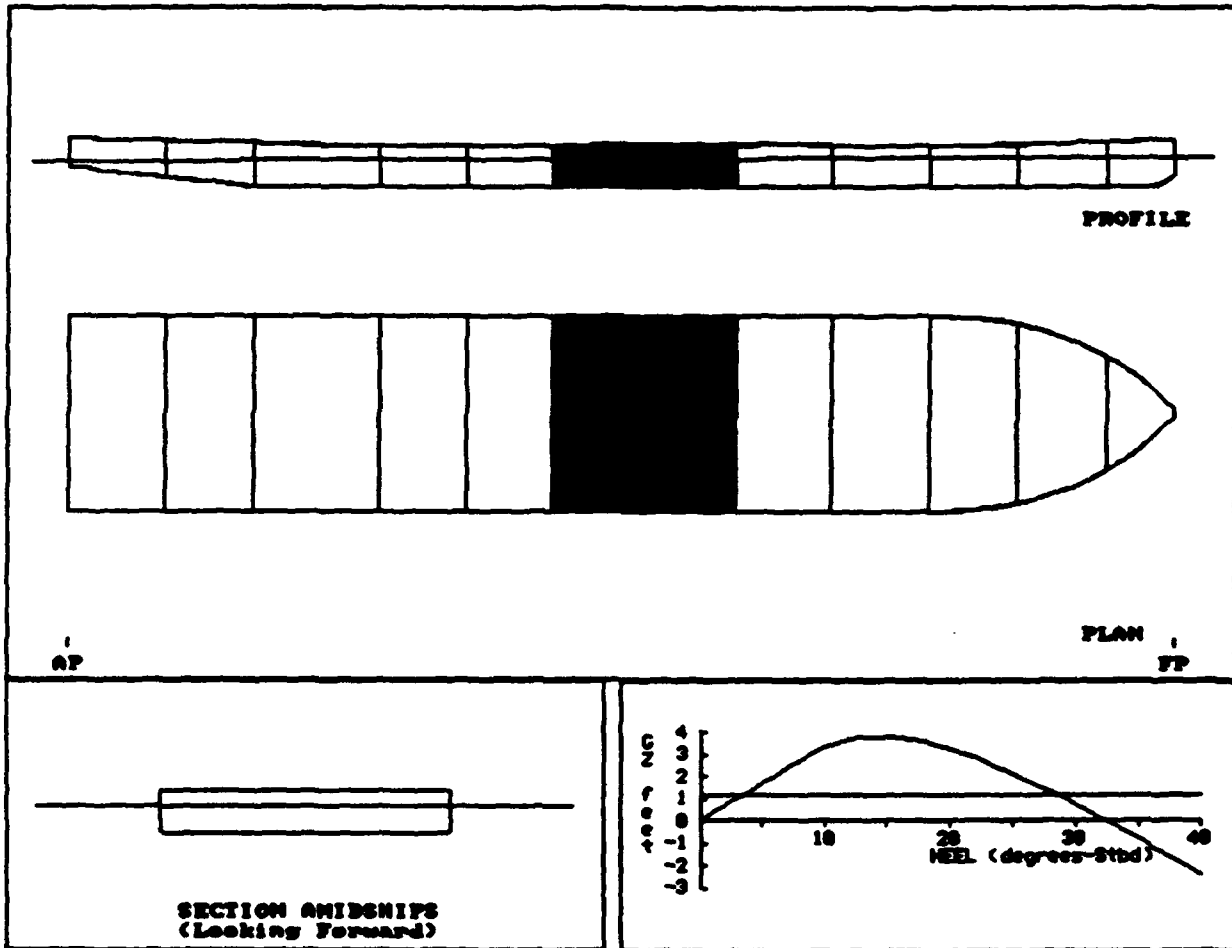

RTRN010B: PUMP 3,4/SEW/H2O
 228' CASINO BOAT

COMPARTMENT FLOODING SUMMARY

At 0.0o Heel	PERM.	FLOODED WTR LTons	% FULL (Damaged)	% FULL (Intact)	SP.VOL. ft3/LT	OUTFLOW LTons
PUMP RM 3	0.85	199.1	FREE	0.0	----	----
WATER TANK	0.95	63.5	FREE	10.0	35.8800	10.8
PUMP RM 4	0.85	133.6	FREE	0.0	----	----
SEWAGE TANK	0.95	77.8	FREE	100.0	35.0063	132.9
Totals		473.9				143.7

INTACT DATA

Draft at AP = 7.680 ft	KMT = 46.192 ft	LCG = 120.627A ft-FP
Draft at FP = 7.680 ft	VCG = 22.500 ft	LCB = 120.627A ft-FP
Displacement = 2348.2 LTons	GMT = 23.692 ft	TCG = 0.000 ft-CL

DRAFT/GZ DATA

HEEL degrees	RIGHTING ARM ft	DRAFT AFT ft	DRAFT FWD ft	FLOODED WATER LTons
0.00	0.000	8.077	9.235	473.9
5.00S	1.716	8.092	9.181	472.7
7.00S	2.401	8.088	9.140	471.5
10.00S	3.313	8.047	9.133	467.9
15.00S	3.793	8.084	9.590	461.6
20.00S	3.288	8.376	10.281	453.9
25.00S	2.159	8.663	11.080	447.9
27.00S	1.617	8.767	11.440	446.1
30.00S	0.753	8.941	11.990	443.8
35.00S	-0.777	9.289	12.946	440.6
40.00S	-2.371	9.652	14.075	438.3

Note: Drafts are measured at A.P. and F.P along ship's centerline

GZ SUMMARY (Evaluated per IMO (SOLAS'90) Rules for Passenger Ships)

	Available	Required
Static Heel Angle	0.00 deg	7.00 deg
Angle at Maximum GZ	15.00S deg	
Maximum GZ	3.793 ft	1.180 ft
Range of Positive GZ	32.50 deg	15.00 deg
CG (upright damaged)	19.568 ft	
Righting Area (0.00-7.00)	59.524 ft-deg	2.820 ft-deg

RTRN011B: PUMP 3,4/SEW/H2O/FUEL (P)
 228' CASINO BOAT

Imaged Compartments:

	PUMP RM 3	WATER TANK	PUMP RM 4	SEWAGE TANK	FUEL TANK (P)	
	DISPLACEMENT LTons	DRAFT AFT ft	DRAFT FWD ft	TRIM ft	HEEL deg.	UPRIGHT GMT ft
INTACT	2,348.2	7.680	7.680	0.000	0.00	23.692
DAMAGED	2,693.9	8.110	9.288	1.178F	0.39P	19.081

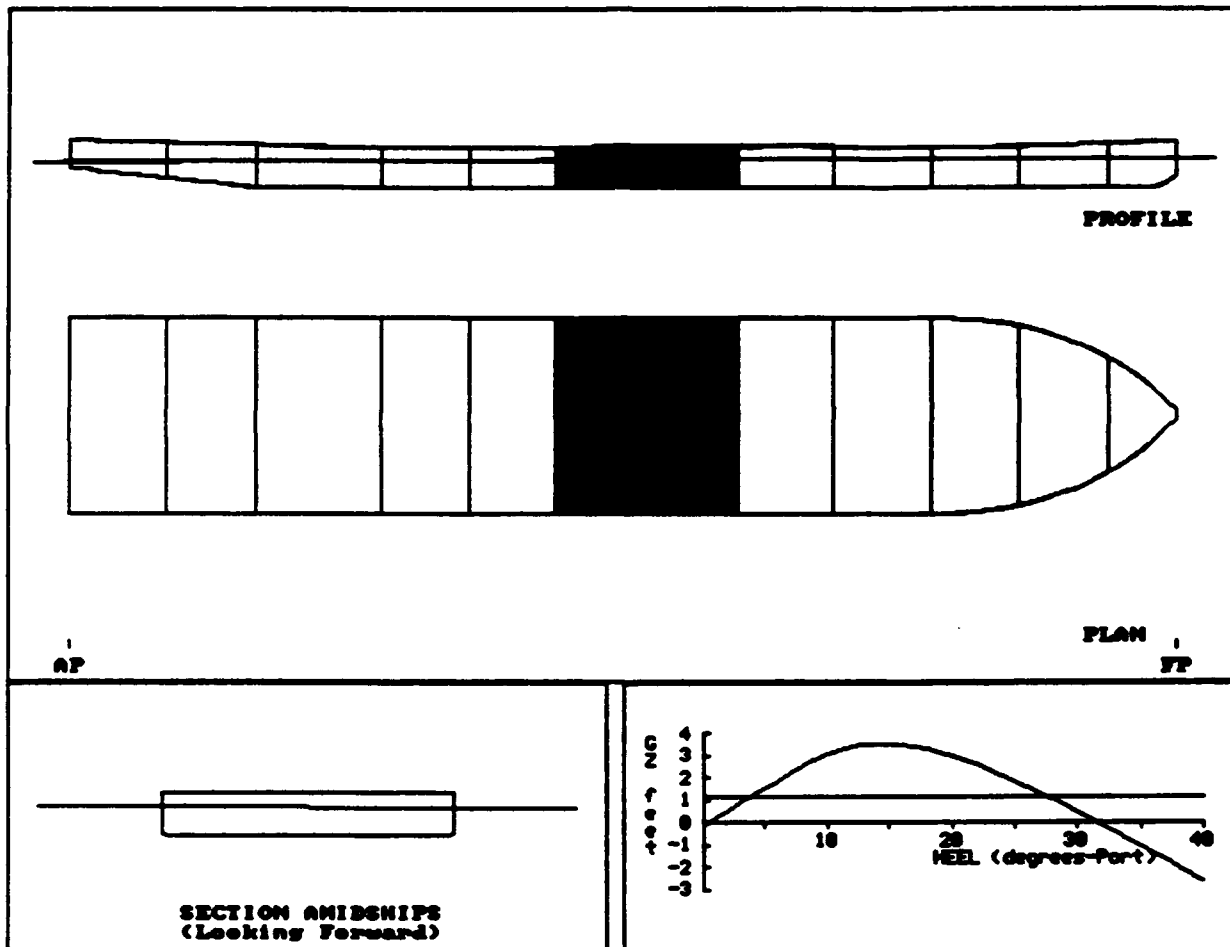

RTRN011B: PUMP 3,4/SEW/H2O/FUEL (P)
 228' CASINO BOAT

COMPARTMENT FLOODING SUMMARY

At 0.4oP Heel	PERM.	FLOODED WTR LTons	% FULL (Damaged)	% FULL (Intact)	SP.VOL. ft3/LT	OUTFLOW LTons
PUMP RM 3	0.85	199.9	FREE	0.0	----	----
WATER TANK	0.95	63.9	FREE	10.0	35.8800	10.8
PUMP RM 4	0.85	134.0	FREE	0.0	----	----
SEWAGE TANK	0.95	78.3	FREE	100.0	35.0063	132.9
FUEL TNK (P)	0.95	15.5	FREE	10.0	38.5800	2.3
Totals		491.7				146.0

INTACT DATA

Draft at AP = 7.680 ft Kmt = 46.192 ft LCG = 120.627A ft-FP
 Draft at FP = 7.680 ft VCG = 22.500 ft LCB = 120.627A ft-FP
 Displacement = 2348.2 LTons GMT = 23.692 ft TCG = 0.000 ft-CL

DRAFT/GZ DATA

HEEL degrees	RIGHTING ARM ft	DRAFT AFT ft	DRAFT FWD ft	FLOODED WATER LTons
0.00	-0.130	8.112	9.286	491.3
5.00P	1.544	8.112	9.286	496.1
7.00P	2.214	8.142	9.218	496.9
10.00P	3.085	8.115	9.231	496.8
15.00P	3.521	8.176	9.711	491.8
20.00P	3.012	8.506	10.425	484.4
25.00P	1.891	8.833	11.258	478.4
27.00P	1.354	8.952	11.635	476.6
30.00P	0.495	9.151	12.209	474.3
35.00P	-1.023	9.547	13.204	471.1
40.00P	-2.604	9.960	14.383	468.7

Note: Drafts are measured at A.P. and F.P along ship's centerline

GZ SUMMARY (Evaluated per IMO (SOLAS'90) Rules for Passenger Ships)

	Available	Required
Static Heel Angle	0.39P deg	7.00 deg
Angle at Maximum GZ	15.00P deg	
Maximum GZ	3.526 ft	1.180 ft
Range of Positive GZ	31.27 deg	15.00 deg
Righting Area (0.39-7.00)	54.615 ft-deg	2.820 ft-deg

RTRN012B: PUMP 3,4/SEW/FUEL (P)
 228' CASINO BOAT

anged Compartments:

	PUMP RM 3	PUMP RM 4	SEWAGE TANK	FUEL TNK (P)			
	DISPLACEMENT		DRAFT AFT	DRAFT FWD	TRIM	HEEL	UPRIGHT GMT
	LTons		ft	ft	ft	deg.	ft
INTACT	2,348.2		7.680	7.680	0.000	0.00	23.692
DAMAGED	2,632.2		8.035	9.002	0.966F	0.37P	19.159

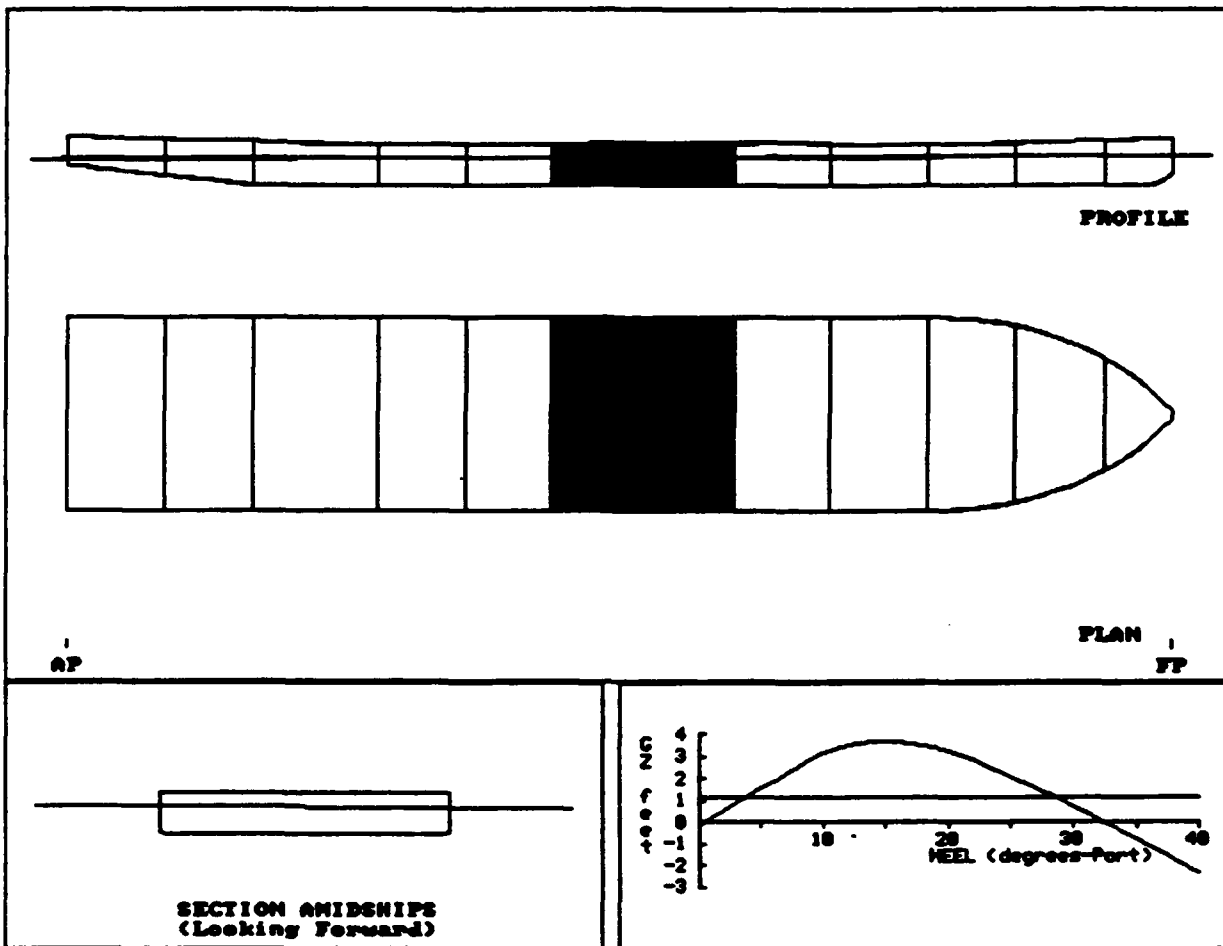

RTRN013B: PUMP 3,4/H2O/FUEL (P)
 228' CASINO BOAT

Imaged Compartments:

PUMP RM 3

PUMP RM 4

FUEL TANK (P)

WATER TANK

	DISPLACEMENT LTons	DRAFT AFT ft	DRAFT FWD ft	TRIM ft	HEEL deg.	UPRIGHT GMT ft
INTACT	2,348.2	7.680	7.680	0.000	0.00	23.692
DAMAGED	2,756.4	8.259	9.493	1.234F	0.40P	18.433

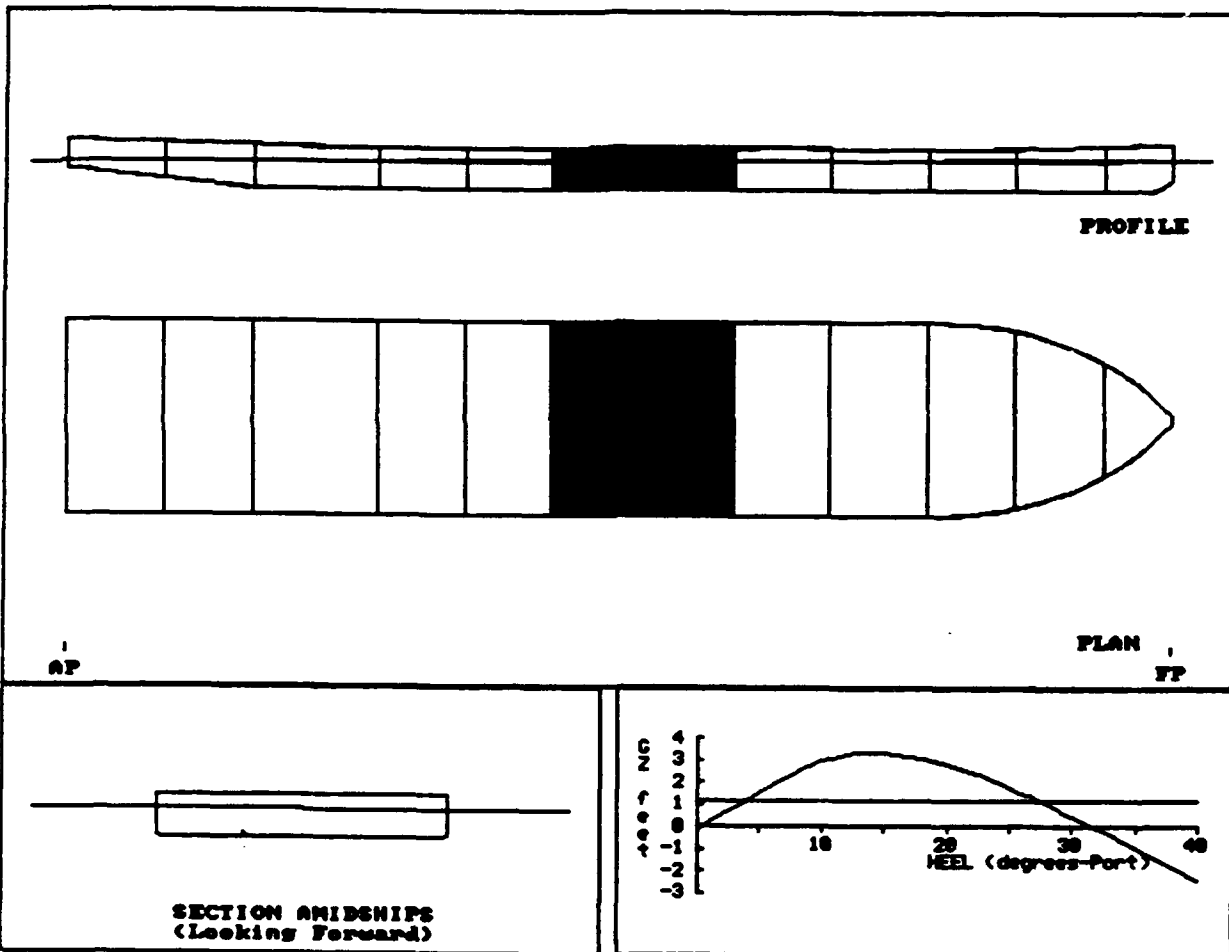

RTRN013B: PUMP 3,4/H2O/FUEL (P)
 228' CASINO BOAT

COMPARTMENT FLOODING SUMMARY

At 0.40P Heel	PERM.	FLOODED WTR LTons	% FULL (Damaged)	% FULL (Intact)	SP.VOL. ft3/LT	OUTFLOW LTons
PUMP RM 3	0.85	203.5	FREE	0.0	----	----
PUMP RM 4	0.85	136.0	FREE	0.0	----	----
FUEL TNK (P)	0.95	15.9	FREE	10.0	38.5800	2.3
WATER TANK	0.95	65.9	FREE	10.0	35.8800	10.8
Totals		421.3				13.1

INTACT DATA

Draft at AP = 7.680 ft KMT = 46.192 ft LCG = 120.627A ft-FP
 Draft at FP = 7.680 ft VCG = 22.500 ft LCB = 120.627A ft-FP
 Displacement = 2348.2 LTons GMT = 23.692 ft TCG = 0.000 ft-CL

DRAFT/GZ DATA

HEEL degrees	RIGHTING ARM ft	DRAFT AFT ft	DRAFT FWD ft	FLOODED WATER LTons
0.00	-0.127	8.260	9.490	420.9
5.00P	1.492	8.260	9.490	425.8
7.00P	2.142	8.297	9.419	426.7
10.00P	2.943	8.280	9.457	426.4
15.00P	3.309	8.376	9.962	417.2
20.00P	2.840	8.758	10.695	405.0
25.00P	1.799	9.145	11.574	396.2
27.00P	1.296	9.286	11.977	393.8
30.00P	0.495	9.558	12.548	390.8
35.00P	-0.935	10.005	13.649	387.2
40.00P	-2.424	10.502	14.910	384.4

Note: Drafts are measured at A.P. and F.P along ship's centerline

GZ SUMMARY (Evaluated per IMO (SOLAS'90) Rules for Passenger Ships)

	Available	Required
Static Heel Angle	0.40P deg	7.00 deg
Angle at Maximum GZ	15.00P deg	
Maximum GZ	3.319 ft	1.180 ft
Range of Positive GZ	31.37 deg	15.00 deg
Righting Area (0.40-15.00)	51.810 ft-deg	2.820 ft-deg

RTRN014B: PUMP 3,4/FUEL (P)
 228' CASINO BOAT

Damaged Compartments:

PUMP RM 3

PUMP RM 4

FUEL TNK (P)

	DISPLACEMENT LTons	DRAFT AFT ft	DRAFT FWD ft	TRIM ft	HEEL deg.	UPRIGHT Gmt ft
INTACT	2,348.2	7.680	7.680	0.000	0.00	23.692
DAMAGED	2,695.0	8.186	9.206	1.019F	0.38P	18.504

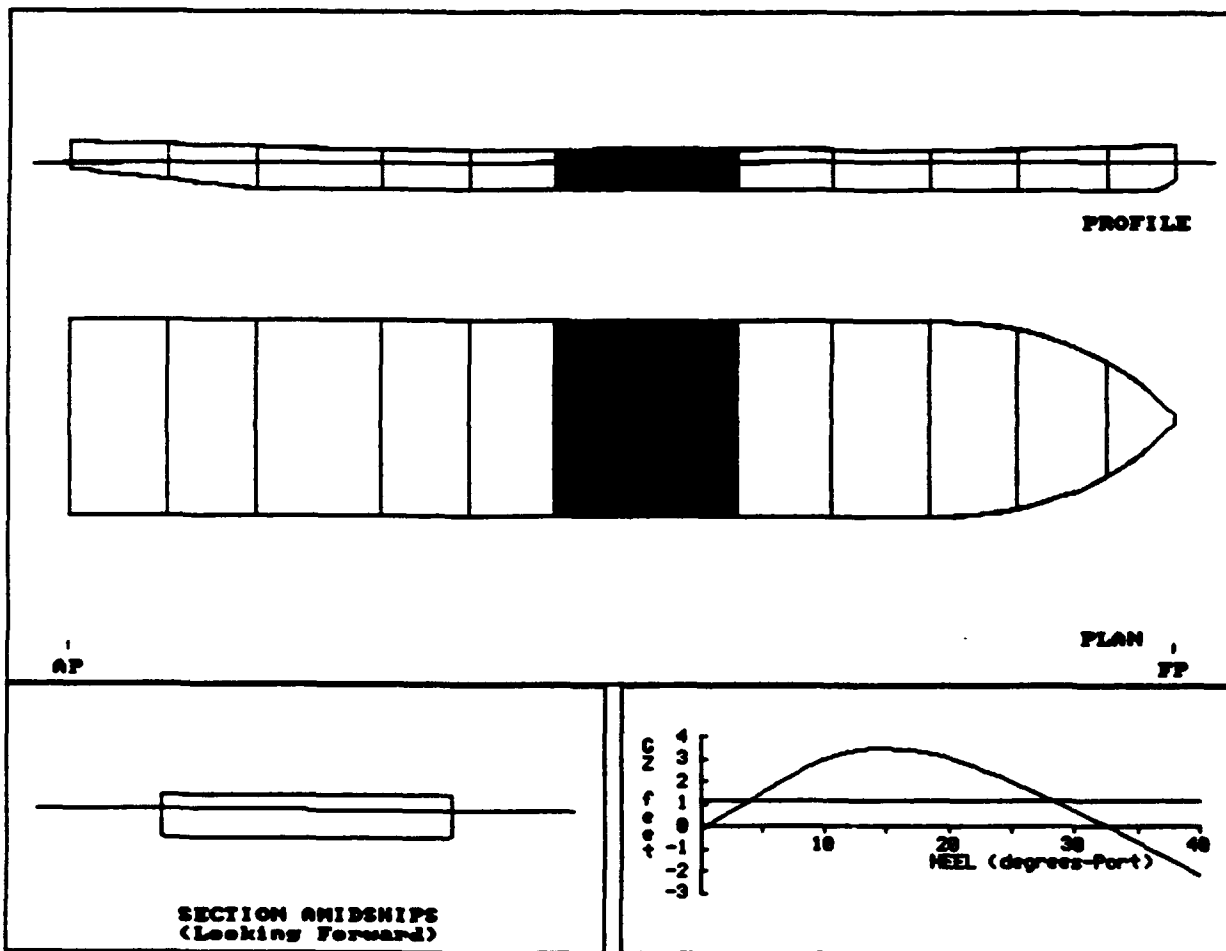

RTRN014B: PUMP 3,4/FUEL (P)
 228' CASINO BOAT

COMPARTMENT FLOODING SUMMARY

At 0.40P Heel	PERM.	FLOODED WTR LTons	% FULL (Damaged)	% FULL (Intact)	SP.VOL. ft3/LT	OUTFLOW LTons
PUMP RM 3	0.85	199.7	FREE	0.0	----	----
PUMP RM 4	0.85	134.0	FREE	0.0	----	----
FUEL TNK (P)	0.95	15.4	FREE	10.0	38.5800	2.3
Totals		349.1				2.3

INTACT DATA

Draft at AP = 7.680 ft	KMT = 46.192 ft	LCG = 120.627A ft-FP
Draft at FP = 7.680 ft	VCG = 22.500 ft	LCB = 120.627A ft-FP
Displacement = 2348.2 LTons	GMT = 23.692 ft	TCG = 0.000 ft-CL

DRAFT/GZ DATA

HEEL degrees	RIGHTING ARM ft	DRAFT AFT ft	DRAFT FWD ft	FLOODED WATER LTons
0.00	-0.122	8.188	9.203	348.8
5.00P	1.502	8.188	9.203	353.6
7.00P	2.153	8.222	9.136	354.9
10.00P	3.009	8.202	9.142	355.0
15.00P	3.486	8.266	9.569	342.9
20.00P	3.072	8.593	10.182	326.0
25.00P	2.048	8.922	10.919	315.6
27.00P	1.549	9.039	11.263	312.9
30.00P	0.752	9.276	11.741	309.5
35.00P	-0.675	9.659	12.666	305.2
40.00P	-2.166	10.089	13.724	301.9

Note: Drafts are measured at A.P. and F.P along ship's centerline

GZ SUMMARY (Evaluated per IMO (SOLAS'90) Rules for Passenger Ships)
 Available Required

Static Heel Angle	0.38P deg	7.00 deg
Angle at Maximum GZ	16.00P deg	
Maximum GZ	3.486 ft	1.180 ft
Range of Positive GZ	32.30 deg	15.00 deg
Righting Area (0.38-1.00)	54.117 ft-deg	2.820 ft-deg

RTRN015B: PUMP 4/STORES 1
 228' CASINO BOAT

Imaged Compartments:
 PUMP RM 4 STORES1

	DISPLACEMENT LTons	DRAFT AFT ft	DRAFT FWD ft	TRIM ft	HEEL deg.	UPRIGHT GMT ft
INTACT	2,348.2	7.680	7.680	0.000	0.00	23.692
DAMAGED	2,740.5	8.993	8.532	0.461A	0.00	18.541

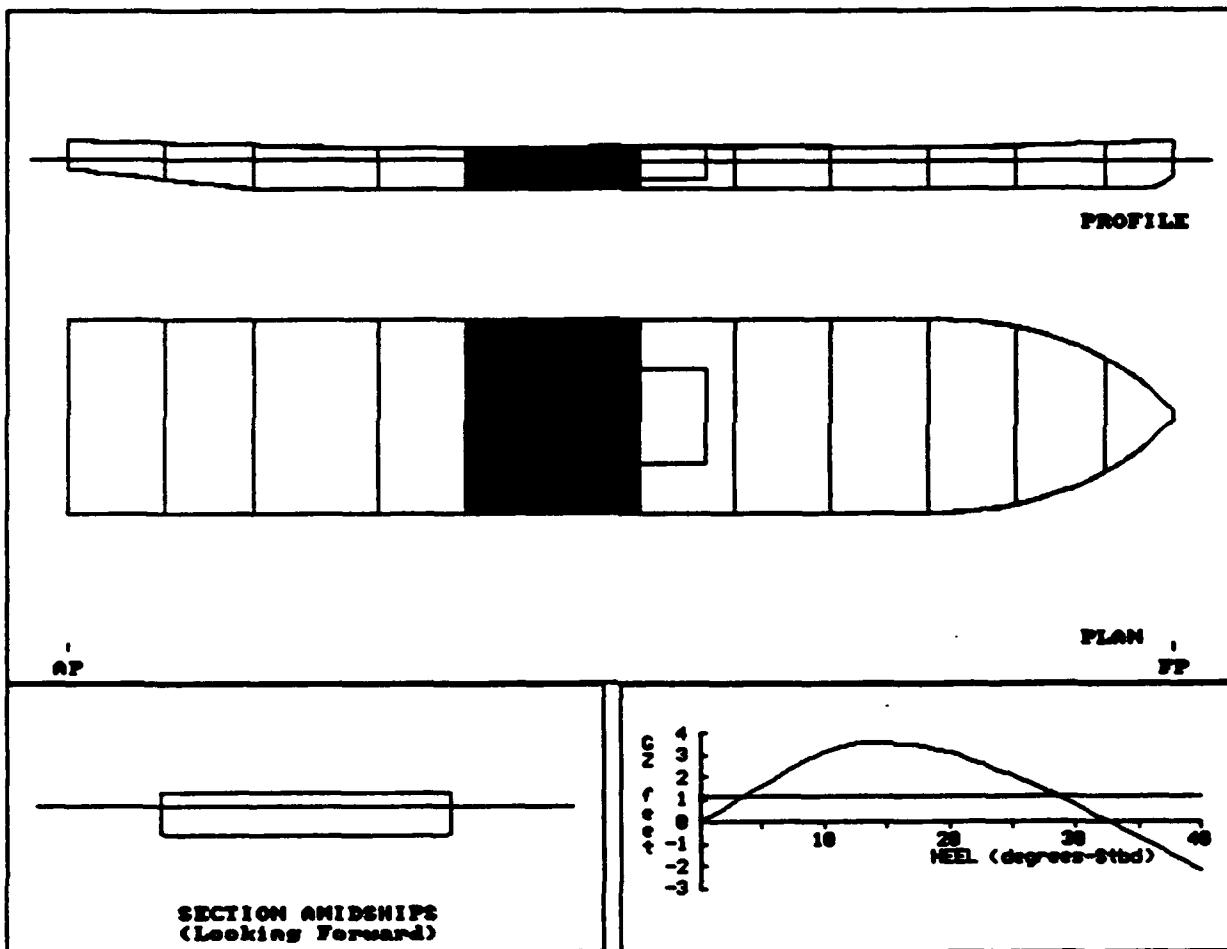

RTRN015B: PUMP 4/STORES 1
 228' CASINO BOAT

COMPARTMENT FLOODING SUMMARY

At 0.0o Heel	PERM.	FLOODED WTR LTons	% FULL (Damaged)	% FULL (Intact)	SP.VOL. ft3/LT	OUTFLOW LTons
PUMP RM 4	0.85	135.1	FREE	0.0	----	----
STORES1	0.95	257.2	FREE	0.0	----	----
Totals		392.3				

INTACT DATA

Draft at AP = 7.680 ft	KMt = 46.192 ft	LCG = 120.627A ft-FP
Draft at FP = 7.680 ft	VCG = 22.500 ft	LCB = 120.627A ft-FP
Displacement = 2348.2 LTons	GMT = 23.692 ft	TCG = 0.000 ft-CL

DRAFT/GZ DATA

HEEL degrees	RIGHTING ARM ft	DRAFT AFT ft	DRAFT FWD ft	FLOODED WATER LTons
0.00	0.000	8.993	8.532	392.3
5.00S	1.629	9.013	8.477	391.9
7.00S	2.293	9.026	8.432	391.4
10.00S	3.175	9.057	8.382	388.2
15.00S	3.580	9.395	8.612	378.1
20.00S	3.121	10.030	9.048	365.5
25.00S	2.083	10.751	9.526	356.7
27.00S	1.584	11.062	9.724	354.3
30.00S	0.780	11.538	10.049	351.3
35.00S	-0.651	12.397	10.645	347.6
40.00S	-2.143	13.369	11.320	344.7

Note: Drafts are measured at A.P. and F.P along ship's centerline

GZ SUMMARY (Evaluated per IMO (SOLAS'90) Rules for Passenger Ships)

	Available	Required
Static Heel Angle	0.00 deg	7.00 deg
Angle at Maximum GZ	15.00S deg	
Maximum GZ	3.589 ft	1.180 ft
Range of Positive GZ	32.76 deg	15.00 deg
Gmt (upright damaged)	18.541 ft	
Righting Area (0.00-3.00)	56.544 ft-deg	2.820 ft-deg

RTRN016B: PUMP 4/STORES 1/FUEL
 228' CASINO BOAT

Imaged Compartments:

PUMP RM 4 STORES1 FUEL TANK (P)

	DISPLACEMENT Ltons	DRAFT AFT ft	DRAFT FWD ft	TRIM ft	HEEL deg.	UPRIGHT GMT ft
INTACT	2,348.2	7.680	7.680	0.000	0.00	23.692
DAMAGED	2,755.6	9.028	8.581	0.448A	0.40P	18.081

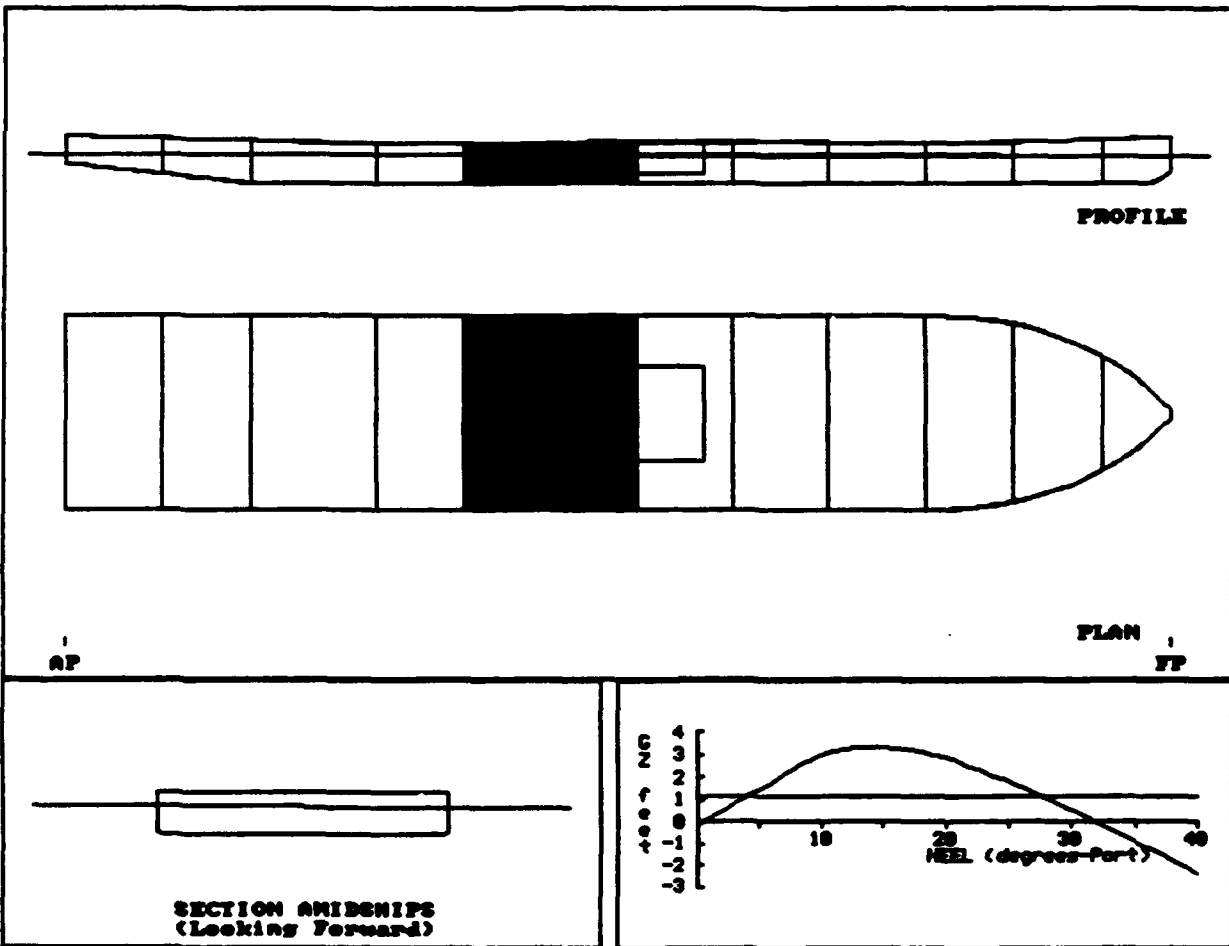

RTRN017B: PUMP 4/STORES 1/FUEL/SEW
 228' CASINO BOAT

Imaged Compartments:

	PUMP RM 4	STORES1	FUEL TANK (P)	SEWAGE TANK			
	DISPLACEMENT LTons	DRAFT AFT ft	DRAFT FWD ft	TRIM ft	HEEL deg.	UPRIGHT GMT ft	
INTACT	2,348.2	7.680	7.680	0.000	0.00	23.692	
DAMAGED	2,693.3	8.866	8.391	0.476A	0.39P	18.715	

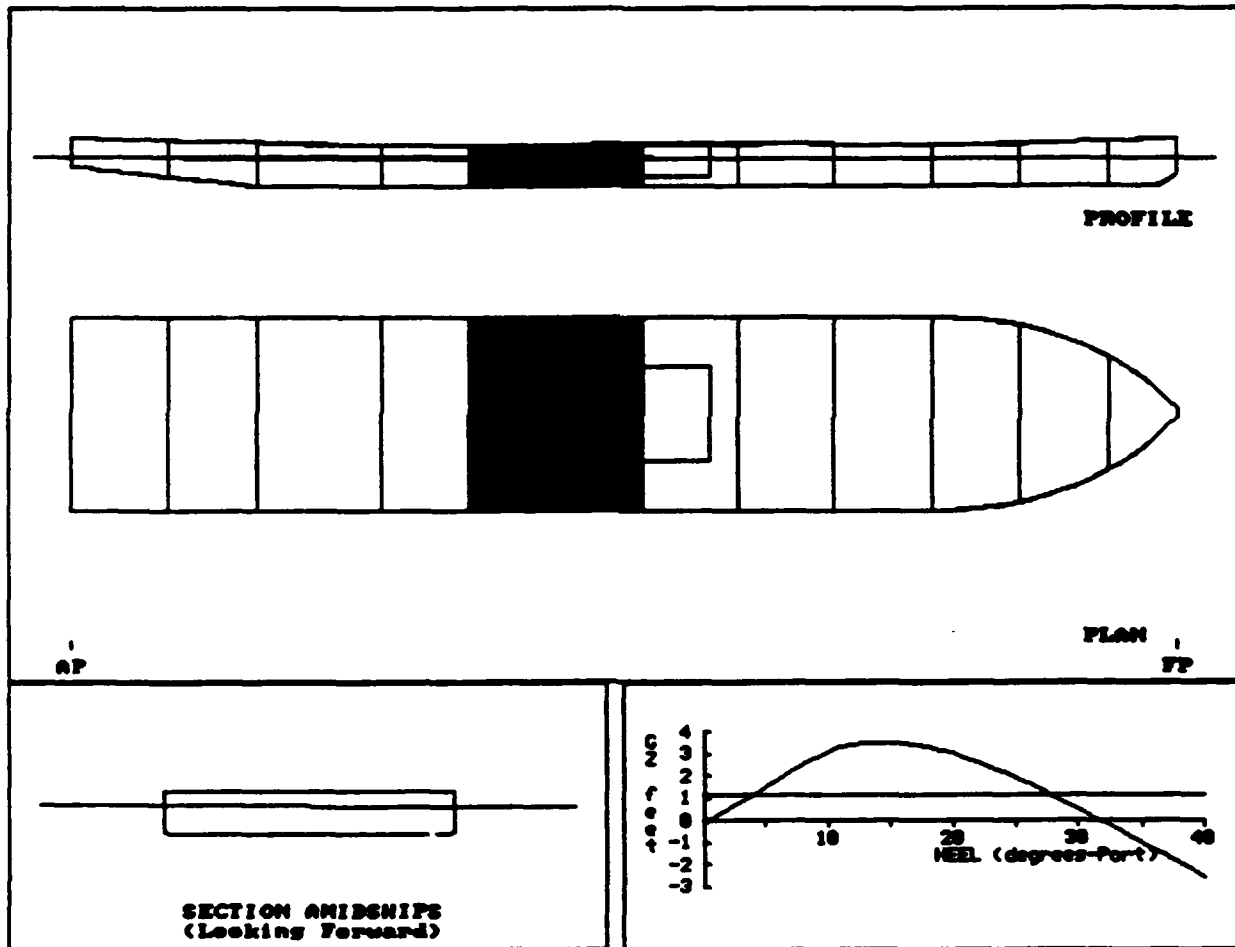

RTRM017B: PUMP 4/STORES 1/FUEL/SEW
 228' CASINO BOAT

COMPARTMENT FLOODING SUMMARY

At 0.40P Heel	PERM.	FLOODED WTR LTons	% FULL (Damaged)	% FULL (Intact)	SP.VOL. ft3/LT	OUTFLOW LTons
PUMP RM 4	0.85	133.6	FREE	0.0	----	----
STORES1	0.95	253.4	FREE	0.0	----	----
FUEL TNK (P)	0.95	15.4	FREE	10.0	38.5800	2.3
SEWAGE TANK	0.95	78.0	FREE	100.0	35.0063	132.9
Totals		480.3				135.2

INTACT DATA

Draft at AP = 7.680 ft	KMT = 46.192 ft	LCG = 120.627A ft-FP
Draft at FP = 7.680 ft	VCG = 22.500 ft	LCB = 120.627A ft-FP
Displacement = 2348.2 LTons	GMT = 23.692 ft	TCG = 0.000 ft-CL

DRAFT/GZ DATA

HEEL degrees	RIGHTING ARM ft	DRAFT AFT ft	DRAFT FWD ft	FLOODED WATER LTons
0.00	-0.129	8.868	8.388	479.9
5.00P	1.517	8.868	8.388	484.7
7.00P	2.186	8.916	8.316	486.4
10.00P	3.096	8.947	8.268	486.7
15.00P	3.537	9.265	8.501	481.5
20.00P	3.032	9.886	8.937	474.1
25.00P	1.923	10.581	9.405	468.1
27.00P	1.392	10.878	9.599	466.3
30.00P	0.541	11.333	9.913	463.9
35.00P	-0.970	12.153	10.489	460.8
40.00P	-2.540	13.079	11.141	458.3

Note: Drafts are measured at A.P. and F.P along ship's centerline

GZ SUMMARY (Evaluated per IMO (SOLAS'90) Rules for Passenger Ships)

	Available	Required
Static Heel Angle	0.39P deg	7.00 deg
Angle at Maximum GZ	15.00P deg	
Maximum GZ	3.545 ft	1.180 ft
Range of Positive GZ	31.43 deg	15.00 deg
Righting Area (0.39-1.00)	54.679 ft-deg	2.820 ft-deg

RTRN018B: PUMP 4/STORES 1/SEW
 228' CASINO BOAT

Imaged Compartments:

PUMP RN 4 STORES1 SEWAGE TANK

	DISPLACEMENT LTons	DRAFT AFT ft	DRAFT FWD ft	TRIM ft	HEEL deg.	UPRIGHT GMT ft
INTACT	2,348.2	7.680	7.680	0.000	0.00	23.692
DAMAGED	2,678.0	8.830	8.342	0.489A	0.00	19.203

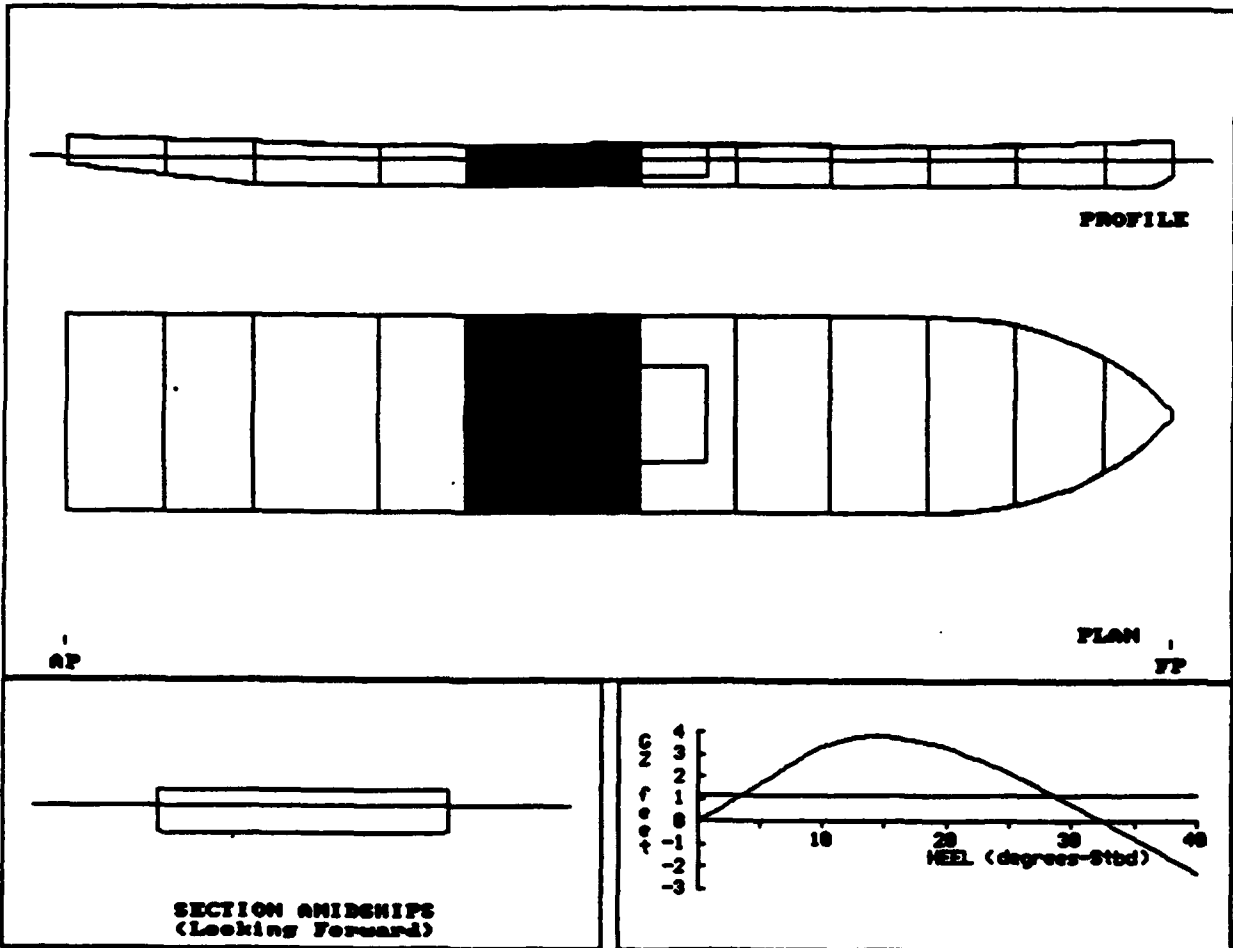

RTRN018B: PUMP 4/STORES 1/SEW
 228' CASINO BOAT

COMPARTMENT FLOODING SUMMARY

At 0.0o Heel	PERM.	FLOODED WTR LTons	% FULL (Damaged)	% FULL (Intact)	SP.VOL. ft3/LT	OUTFLOW LTons
PUMP RM 4	0.85	133.1	FREE	0.0	----	----
STORES1	0.95	252.2	FREE	0.0	----	----
SEWAGE TANK	0.95	77.5	FREE	100.0	35.0063	132.9
Totals		462.7				132.9

INTACT DATA

Draft at AP = 7.680 ft KMT = 46.192 ft LCG = 120.627A ft-FP
 Draft at FP = 7.680 ft VCG = 22.500 ft LCB = 120.627A ft-FP
 Displacement = 2348.2 LTons GMT = 23.692 ft TCG = 0.000 ft-CL

DRAFT/GZ DATA

HEEL degrees	RIGHTING ARM ft	DRAFT AFT ft	DRAFT FWD ft	FLOODED WATER LTons
0.00	0.000	8.830	8.342	462.7
5.00S	1.687	8.850	8.288	462.0
7.00S	2.373	8.859	8.243	461.3
10.00S	3.322	8.876	8.180	458.2
15.00S	3.811	9.158	8.401	451.6
20.00S	3.308	9.741	8.814	443.8
25.00S	2.191	10.392	9.254	437.9
27.00S	1.656	10.668	9.437	436.0
30.00S	0.799	11.093	9.733	433.7
35.00S	-0.724	11.859	10.275	430.5
40.00S	-2.308	12.724	10.891	428.1

Note: Drafts are measured at A.P. and F.P along ship's centerline

GZ SUMMARY (Evaluated per IMO (SOLAS'90) Rules for Passenger Ships)
 Available Required

Static Heel Angle	0.00 deg	7.00 deg
Angle at Maximum GZ	15.00S deg	
Maximum GZ	3.813 ft	1.180 ft
Range of Positive GZ	32.66 deg	15.00 deg
Gmt (upright damaged)	19.203 ft	
Righting Area (0.00-7.00)	59.578 ft-deg	2.820 ft-deg

RTRN019B: STORES 1.2
 228' CASINO BOAT

Imaged Compartments:
 STORES1 STORES2

	DISPLACEMENT LTONS	DRAFT AFT ft	DRAFT FWD ft	TRIM ft	HEEL deg.	UPRIGHT Gmt ft
INTACT	2,348.2	7.680	7.680	0.000	0.00	23.692
DAMAGED	2,900.8	10.224	8.054	2.170A	0.00	17.060

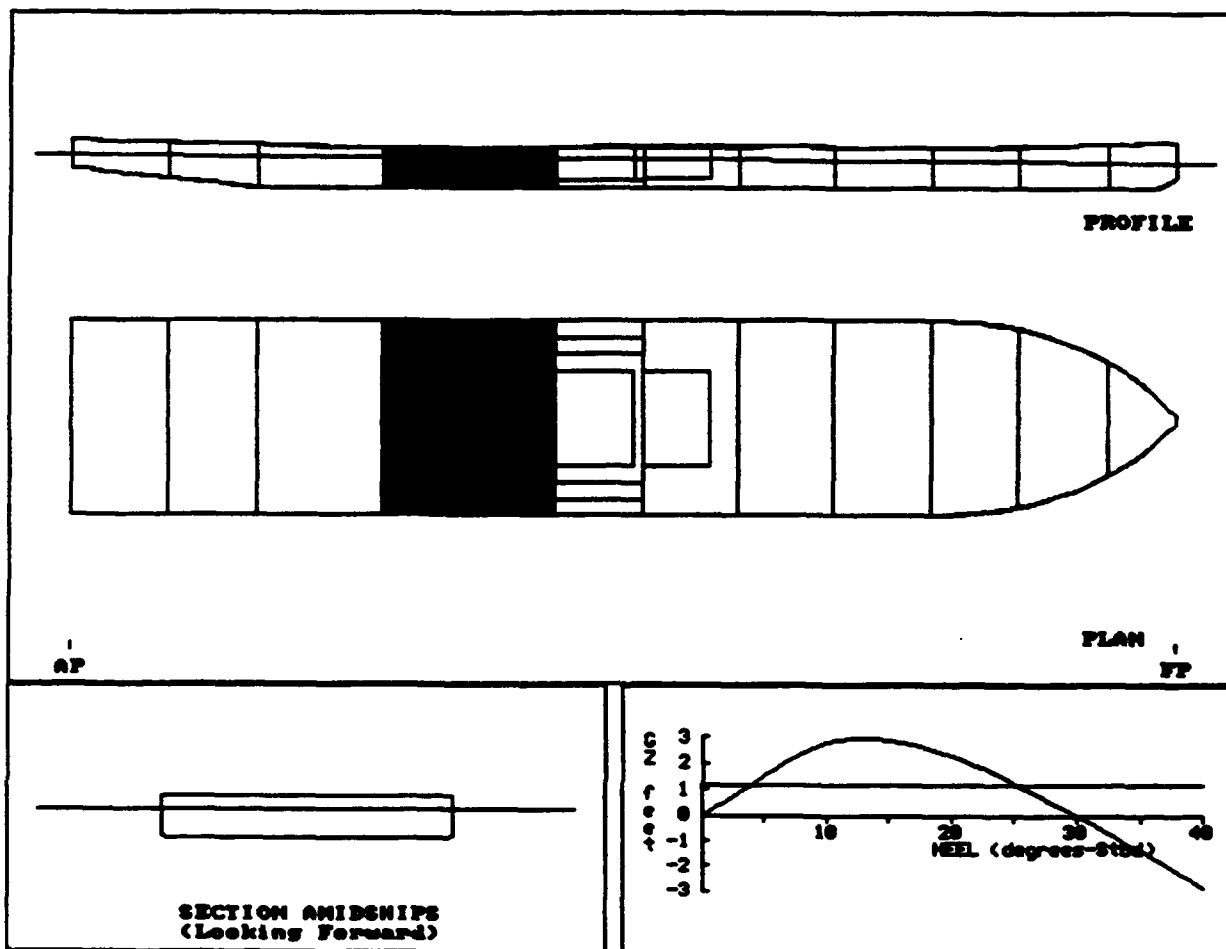

RTRM019B: STORES 1.2
 228' CASINO BOAT

COMPARTMENT FLOODING SUMMARY

At 0.0o Heel	PERM.	FLOODED WTR LTons	% FULL (Damaged)	% FULL (Intact)	SP.VOL. ft3/LT	OUTFLOW LTons
STORES1	0.95	273.3	FREE	0.0	----	----
STORES2	0.95	279.3	FREE	0.0	----	----
Totals		552.6				

INTACT DATA

Draft at AP = 7.680 ft	KMT = 46.192 ft	LCG = 120.627A ft-FP
Draft at FP = 7.680 ft	VCG = 22.500 ft	LCB = 120.627A ft-FP
Displacement = 2348.2 LTons	GMT = 23.692 ft	TCG = 0.000 ft-CL

DRAFT/GZ DATA

HEEL degrees	RIGHTING ARM ft	DRAFT AFT ft	DRAFT FWD ft	FLOODED WATER LTons
0.00	0.000	10.224	8.054	552.6
5.00S	1.500	10.249	7.994	552.3
7.00S	2.109	10.268	7.948	551.9
10.00S	2.788	10.413	7.882	546.7
15.00S	2.886	11.194	7.936	539.1
20.00S	2.304	12.358	8.190	531.9
25.00S	1.269	13.756	8.451	525.4
27.00S	0.778	14.359	8.553	523.5
30.00S	-0.010	15.302	8.720	521.1
35.00S	-1.403	16.997	9.031	517.8
40.00S	-2.854	18.920	9.380	515.4

Note: Drafts are measured at A.P. and F.P along ship's centerline

GZ SUMMARY (Evaluated per IMO (SOLAS'90) Rules for Passenger Ships)

	Available	Required
Static Heel Angle	0.00 deg	7.00 deg
Angle at Maximum GZ	14.00S deg	
Maximum GZ	2.970 ft	1.180 ft
Range of Positive GZ	29.96 deg	15.00 deg
Gmt (upright damaged)	17.060 ft	
Righting Area (0.00-3.00)	46.807 ft-deg	2.820 ft-deg

RTRN020B: STORES 2/ER
 228' CASINO BOAT

Damaged Compartments:
 STORES2 ENGINE RM

	DISPLACEMENT LTons	DRAFT AFT ft	DRAFT FWD ft	TRIM ft	HEEL deg.	UPRIGHT Gmt ft
INTACT	2,348.2	7.680	7.680	0.000	0.00	23.692
DAMAGED	3,071.4	12.283	6.649	5.634A	0.00	15.891

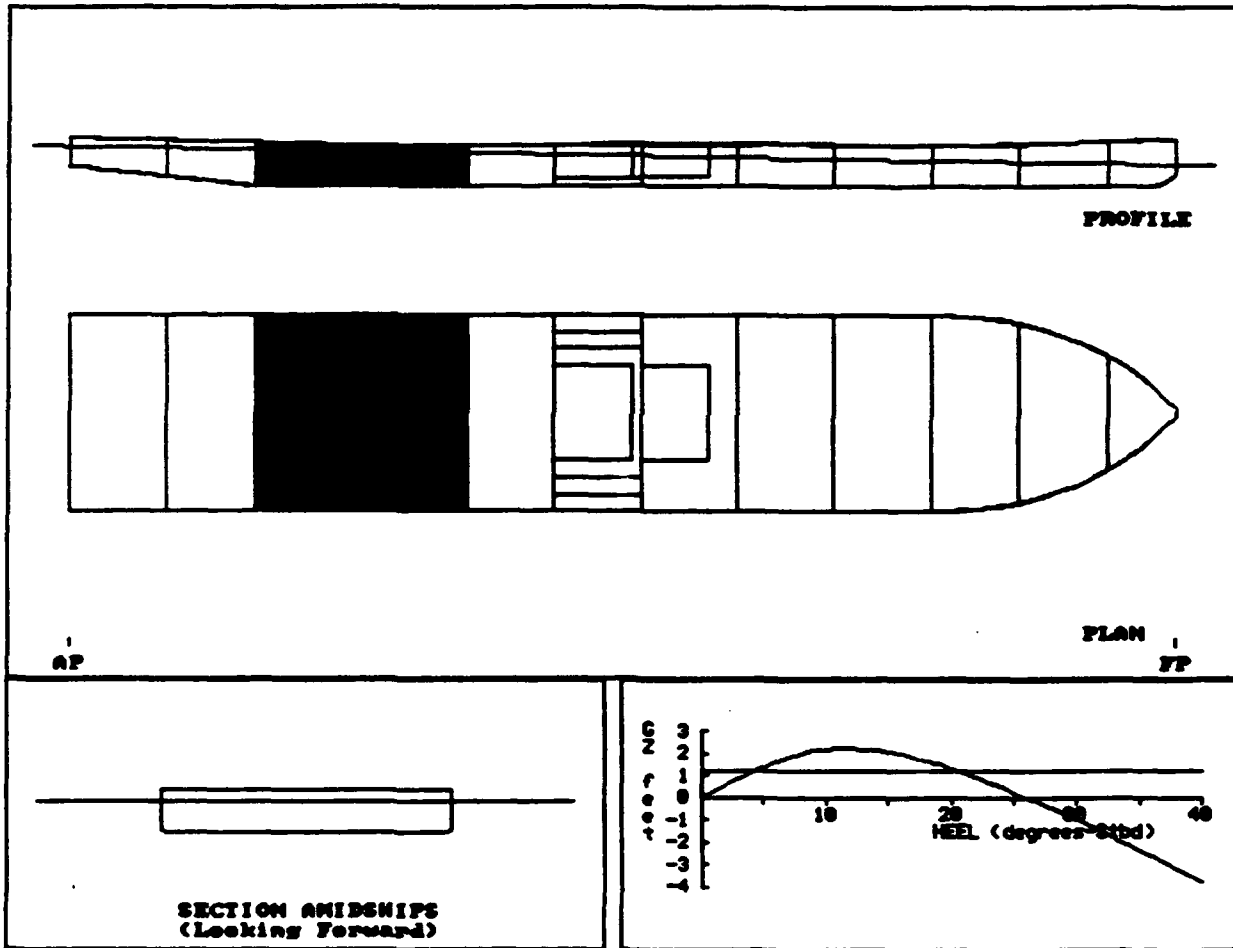

RTRN020B: STORES 2/ER
 228' CASINO BOAT

COMPARTMENT FLOODING SUMMARY

At 0.0o Heel	PERM.	FLOODED WTR LTons	% FULL (Damaged)	% FULL (Intact)	SP.VOL. ft3/LT	OUTFLOW LTons
STORES2	0.95	307.1	FREE	0.0	----	----
ENGINE RM	0.85	416.1	FREE	0.0	----	----
Totals		723.2				

INTACT DATA

Draft at AP = 7.680 ft Kmt = 46.192 ft LCG = 120.627A ft-FP
 Draft at FP = 7.680 ft VCG = 22.500 ft LCB = 120.627A ft-FP
 Displacement = 2348.2 LTons Gmt = 23.692 ft TCG = 0.000 ft-CL

DRAFT/GZ DATA

HEEL degrees	RIGHTING ARM ft	DRAFT AFT ft	DRAFT FWD ft	FLOODED WATER LTons
0.00	0.000	12.283	6.649	723.2
5.00S	1.387	12.330	6.573	722.9
7.00S	1.840	12.452	6.496	718.1
10.00S	2.191	12.992	6.256	713.1
15.00S	2.049	14.420	5.976	708.9
20.00S	1.333	16.348	5.758	707.3
25.00S	0.269	18.669	5.481	705.6
27.00S	-0.221	19.709	5.331	704.8
30.00S	-0.991	21.318	5.124	702.9
35.00S	-2.350	24.312	4.701	700.2
40.00S	-3.744	27.687	4.243	697.8

Note: Drafts are measured at A.P. and F.P along ship's centerline

GZ SUMMARY (Evaluated per IMO (SOLAS'90) Rules for Passenger Ships)
 Available Required

Static Heel Angle	0.00 deg	7.00 deg
Angle at Maximum GZ	12.00S deg	
Maximum GZ	2.226 ft	1.180 ft
Range of Positive GZ	26.11 deg	15.00 deg
Gmt (upright damaged)	15.891 ft	
Righting Area (0.00-7.00)	34.708 ft-deg	2.820 ft-deg

RTRN021B: ER/PUMP 5
 228' CASINO BOAT

Imaged Compartments:
 ENGINE RM PUMP RM 5

	DISPLACEMENT LTons	DRAFT AFT ft	DRAFT FWD ft	TRIM ft	HEEL deg.	UPRIGHT Gmt ft
INTACT	2,348.2	7.680	7.680	0.000	0.00	23.692
DAMAGED	3,045.9	13.138	5.455	7.683A	0.00	15.783

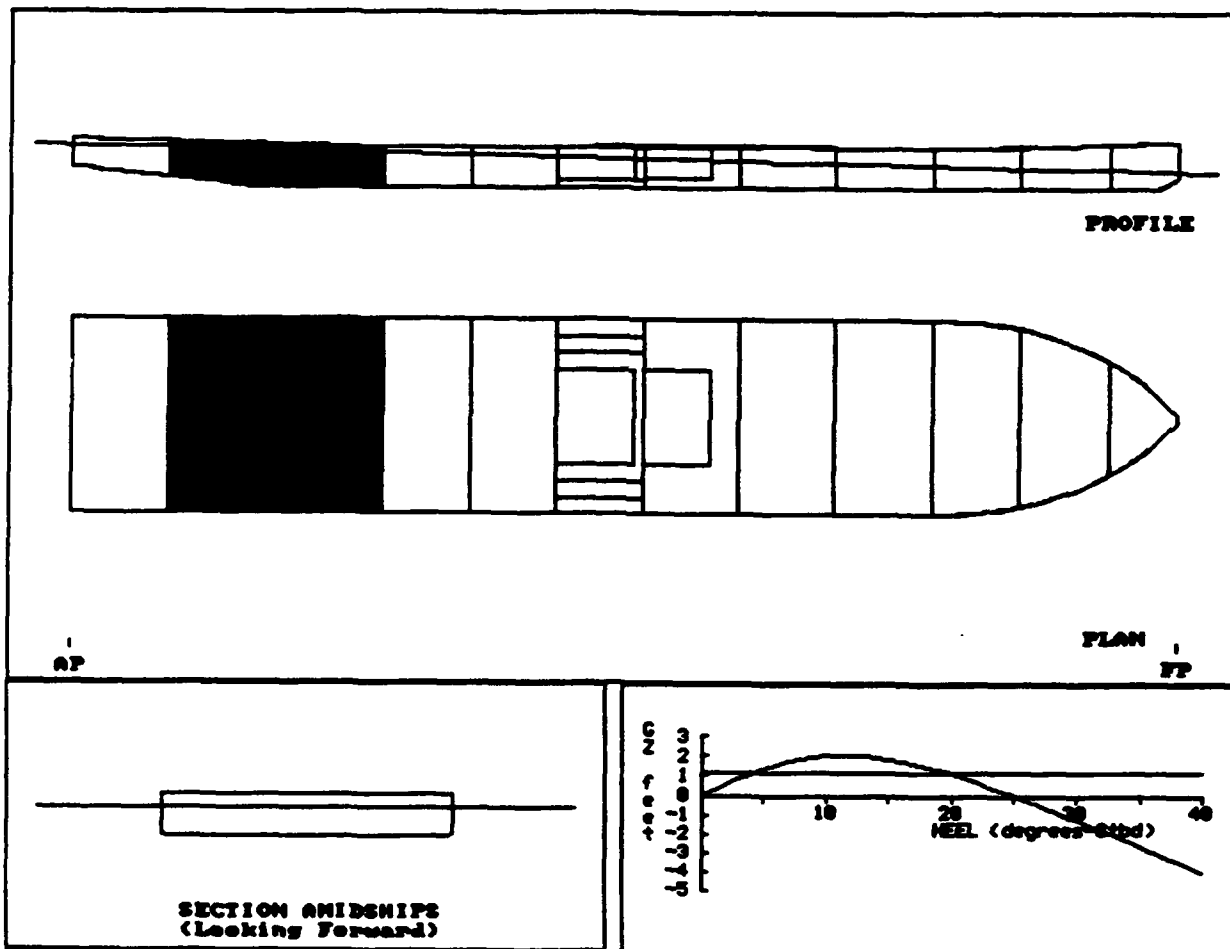

RTRN021B: ER/PUMP 5
 228' CASINO BOAT

COMPARTMENT FLOODING SUMMARY

At 0.0o Heel	PERM.	FLOODED WTR LTons	% FULL (Damaged)	% FULL (Intact)	SP.VOL. ft3/LT	OUTFLOW LTons
ENGINE RM	0.85	431.1	FREE	0.0	----	----
PUMP RM 5	0.85	266.7	FREE	0.0	----	----
Totals		697.8				

INTACT DATA

Draft at AP = 7.680 ft Kmt = 46.192 ft LCG = 120.627A ft-FP
 Draft at FP = 7.680 ft VCG = 22.500 ft LCB = 120.627A ft-FP
 Displacement = 2348.2 LTons GMT = 23.692 ft TCG = 0.000 ft-CL

DRAFT/GZ DATA

HEEL degrees	RIGHTING ARM ft	DRAFT AFT ft	DRAFT FWD ft	FLOODED WATER LTons
0.00	0.000	13.138	5.455	697.8
5.00S	1.331	13.250	5.348	696.5
7.00S	1.716	13.502	5.199	692.6
10.00S	2.015	14.199	4.884	689.9
15.00S	1.864	16.024	4.274	692.5
20.00S	1.110	18.418	3.616	697.9
25.00S	0.018	21.275	2.838	703.6
27.00S	-0.470	22.503	2.515	705.2
30.00S	-1.255	24.529	1.942	708.1
35.00S	-2.620	28.194	0.927	710.9
40.00S	-4.017	32.391	-0.250	712.7

Note: Drafts are measured at A.P. and F.P along ship's centerline

GZ SUMMARY (Evaluated per IMO (SOLAS'90) Rules for Passenger Ships)

	Available	Required
Static Heel Angle	0.00 deg	7.00 deg
Angle at Maximum GZ	12.00S deg	
Maximum GZ	2.044 ft	1.180 ft
Range of Positive GZ	25.07 deg	15.00 deg
Gmt (upright damaged)	15.783 ft	
Righting Area (0.00-7.00)	31.592 ft-deg	2.820 ft-deg

RTRN022B: PUMP5/STEER
 228' CASINO BOAT

Imaged Compartments:
 STEER/VOID PUMP RM 5

	DISPLACEMENT LTons	DRAFT AFT ft	DRAFT FWD ft	TRIM ft	HEEL deg.	UPRIGHT GMT ft
INTACT	2,348.2	7.680	7.680	0.000	0.00	23.692
DAMAGED	2,804.8	12.096	5.199	6.897A	0.00	15.688

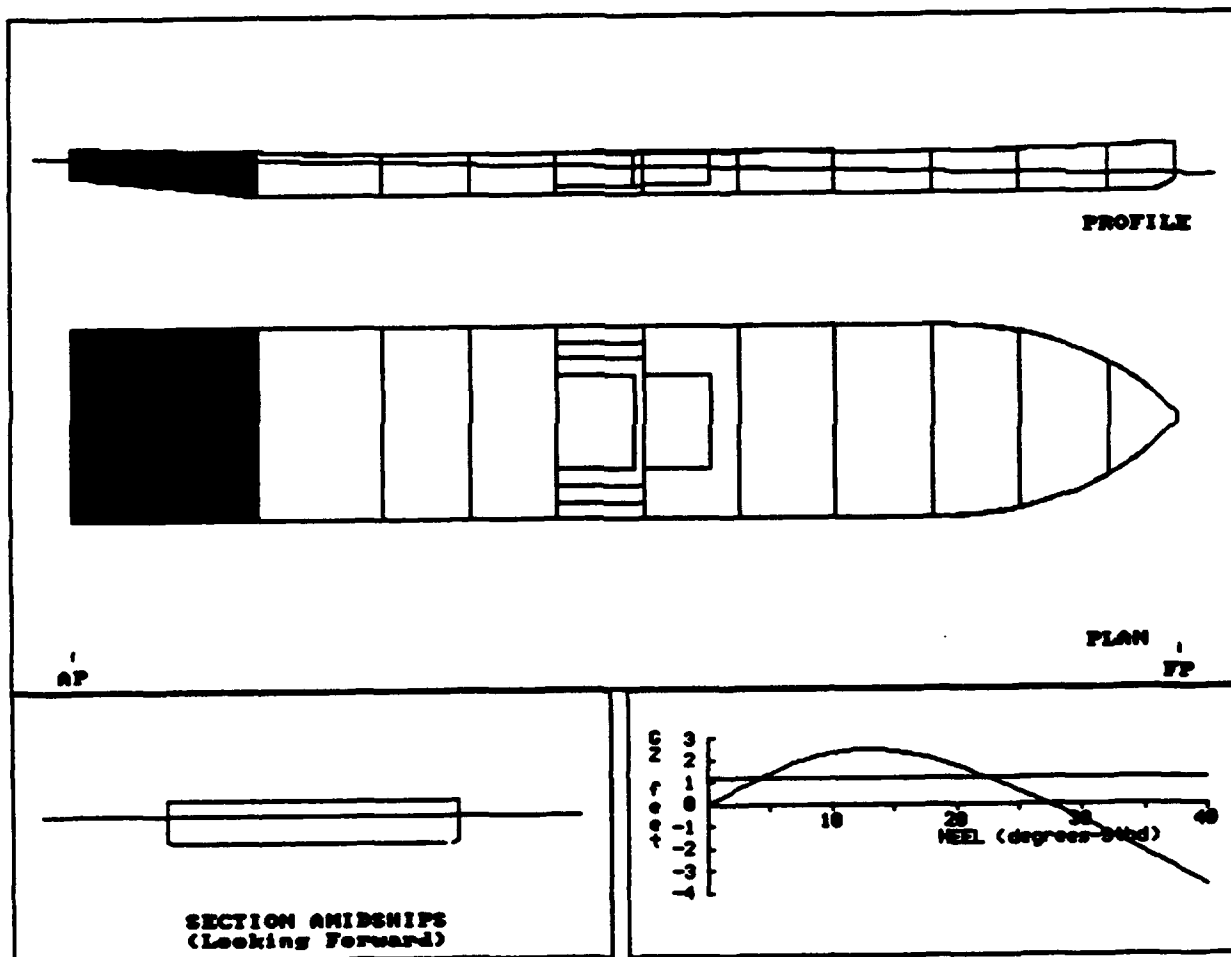

RTRN022B: PUMPS/STEER
 228' CASINO BOAT

COMPARTMENT FLOODING SUMMARY

At 0.0o Heel	PERM.	FLOODED WTR LTons	% FULL (Damaged)	% FULL (Intact)	SP.VOL. ft3/LT	OUTFLOW LTons
STEER/VOID	0.95	214.6	FREE	0.0	----	----
PUMP RM 5	0.85	242.0	FREE	0.0	----	----
Totals		456.6				

INTACT DATA

Draft at AP = 7.680 ft Kmt = 46.192 ft LCG = 120.627A ft-FP
 Draft at FP = 7.680 ft VCG = 22.500 ft LCB = 120.627A ft-FP
 Displacement = 2348.2 LTons GMT = 23.692 ft TCG = 0.000 ft-CL

DRAFT/GZ DATA

HEEL degrees	RIGHTING ARM ft	DRAFT AFT ft	DRAFT FWD ft	FLOODED WATER LTons
0.00	0.000	12.096	5.199	456.6
5.00S	1.377	12.154	5.120	459.3
7.00S	1.872	12.253	5.046	459.9
10.00S	2.365	12.771	4.754	464.1
15.00S	2.441	14.401	4.061	478.3
20.00S	1.731	16.791	3.132	496.8
25.00S	0.613	19.624	2.055	512.2
27.00S	0.103	20.841	1.600	517.1
30.00S	-0.717	22.863	0.807	524.8
35.00S	-2.146	26.543	-0.616	535.0
40.00S	-3.621	30.765	-2.263	543.4

Note: Drafts are measured at A.P. and F.P along ship's centerline

GZ SUMMARY (Evaluated per IMO (SOLAS'90) Rules for Passenger Ships)

	Available	Required
Static Heel Angle	0.00 deg	7.00 deg
Angle at Maximum GZ	14.00S deg	
Maximum GZ	2.518 ft	1.180 ft
Range of Positive GZ	27.39 deg	15.00 deg
Gmt (upright damaged)	15.688 ft	
Righting Area (0.00-%.00)	39.253 ft-deg	2.820 ft-deg

**APPENDIX B
HYDROSTATICS AND
DAMAGE STABILITY
OUTPUT**

274' PADDLE WHEELER

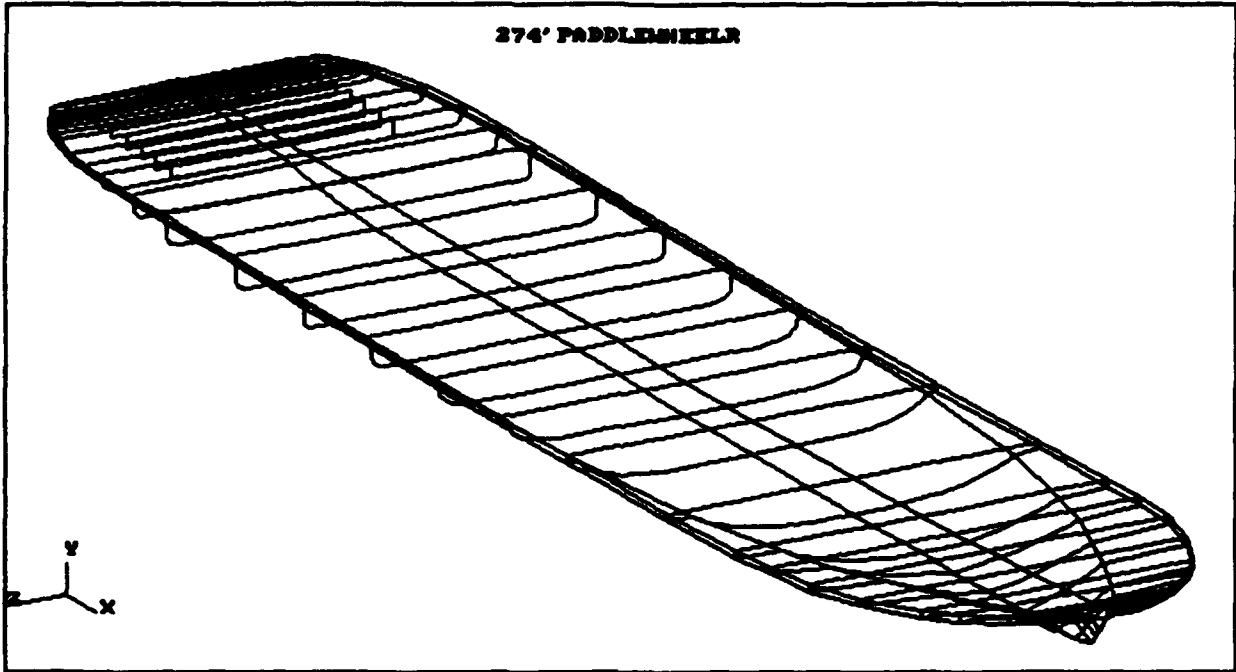

**DAMAGE STABILITY SUMMARY
 274' PADDLEWHEELR**

CASE No.	FILE NAME	DAMAGED COMP. LISTING	---Intact Condition---			-----Equilibrium Condition After Damage-----					
			MM.DRAFT (ft)	VCG (ft)	GMT (ft)	HEEL (deg)	MAX.GZ (ft)	RANGE (deg)	AREA (ft-deg)	DAM.GMT (ft)	SURVIVAL
1	DPRT001A	1,2	6.490	19.670	42.591	0.0	6.858	40.0	113.3	41.842	Yes
2	DPRT002A	2,3	6.490	19.670	42.591	0.0	5.929	37.8	99.8	42.374	Yes
3	DPRT003A	3,7	6.490	19.670	42.591	0.0	5.385	36.2	90.1	41.090	Yes
4	DPRT004A	7,10	6.490	19.670	42.591	0.0	4.677	33.8	78.6	42.580	Yes
5	DPRT005A	10,11	6.490	19.670	42.591	5.1S	1.089	14.5	10.4	----	No *F
6	DPRT006A	11,15	6.490	19.670	42.591	4.5S	1.491	17.6	17.2	----	Yes
7	DPRT007A	15,16,17	6.490	19.670	42.591	0.2S	4.978	35.0	83.0	----	Yes
8	DPRT008A	16,17,19	6.490	19.670	42.591	0.1S	5.565	37.1	93.6	----	Yes
9	DPRT009A	16,17,19,18	6.490	19.670	42.591	0.2S	3.517	28.7	57.5	----	Yes
10	DPRT010A	2,3,4	6.490	19.670	42.591	0.0	5.903	37.7	99.4	42.795	Yes
11	DPRT011A	10,11,12,13	6.490	19.670	42.591	90.0S	-0.824	0.0	0.0	----	Capsize *F
12	DPRT012A	10,12,13	6.490	19.670	42.591	0.0	4.211	31.5	71.1	50.272	Yes
13	DPRT013A	13,14,15	6.490	19.670	42.591	0.0	4.643	33.3	79.1	44.678	Yes
14	DPRT014A	13,14,15,11	6.490	19.670	42.591	90.0S	-0.335	0.0	0.0	----	Capsize *F
15	DPRT015A	15,16,17,18	6.490	19.670	42.591	0.6S	2.460	23.7	36.9	----	Yes

*F WARNING: The required GMT for non-survival cases does not meet all survival criteria.

**DAMAGE STABILITY SUMMARY
 274' PADDLEWHEEL**

Ca	No.	FILE NAME	DAMAGED COMP. LISTING	---Intact Condition---			-----Equilibrium Condition After Damage-----					
				MIN.DRAFT (ft)	VCG (ft)	GMT (ft)	HEEL (deg)	MAX.GZ (ft)	RANGE (deg)	AREA (ft-deg)	DAM.GMT (ft)	SURVIVAL
	1	RTRN001B	1,2	6.225	20.190	43.596	0.0	7.255	40.0	119.0	43.326	Yes
	2	RTRN002B	2,3	6.225	20.190	43.596	0.0	6.468	38.7	108.1	42.108	Yes
	3	RTRN003B	3,7	6.225	20.190	43.596	0.0	5.927	37.4	98.7	40.569	Yes
	4	RTRN004B	7,10	6.225	20.190	43.596	0.0	5.219	35.1	87.1	39.720	Yes
	5	RTRN005B	10,11	6.225	20.190	43.596	5.0S	1.422	16.4	15.3	----	Yes
	6	RTRN006B	11,15	6.225	20.190	43.596	4.5S	1.603	18.2	19.1	----	Yes
	7	RTRN007B	15,16,17	6.225	20.190	43.596	0.2S	5.144	35.2	85.7	----	Yes
	8	RTRN008B	16,17,19	6.225	20.190	43.596	0.2S	5.768	37.3	96.3	----	Yes
	9	RTRN009B	16,17,19,18	6.225	20.190	43.596	0.3S	3.526	28.6	57.4	----	Yes
	10	RTRN010B	2,3,4	6.225	20.190	43.596	0.0	6.445	38.7	107.9	42.165	Yes
	11	RTRN011B	10,11,12,13	6.225	20.190	43.596	90.0S	-0.394	0.0	0.0	----	Capsize *F
	12	RTRN012B	10,12,13	6.225	20.190	43.596	0.0	4.731	33.0	80.0	48.314	Yes
	13	RTRN013B	13,14,15	6.225	20.190	43.596	0.0	4.895	33.8	83.8	44.574	Yes
	14	RTRN014B	13,14,15,11	6.225	20.190	43.596	90.0S	-0.249	0.0	0.0	----	Capsize *F
	15	RTRN015B	15,16,17,18	6.225	20.190	43.596	0.7S	2.438	23.6	36.9	----	Yes

*F WARNING: The required GMT for non-survival cases does not meet all survival criteria.

HYDROSTATIC TABLES
274' PADDLEWHEEL

HOLDED DRAFT (ft)		4.000	5.000	5.500	5.750	6.000	6.250	6.500	6.700
DISP.MLD. (LTons-SW)		850	1,175	1,344	1,430	1,518	1,606	1,695	1,768
DISP.TOTAL (LTons-SW)		863	1,191	1,362	1,449	1,537	1,626	1,717	1,789
DISP.TOTAL (LTons-FW)		842	1,162	1,329	1,414	1,500	1,587	1,675	1,746
LCB (ft-FP)		134.073A	134.456A	134.617A	134.693A	134.767A	134.840A	134.910A	134.951A
TCB (ft-CL)		0.000	0.000	0.000	0.000	0.000	0.000	0.000	0.000
KB (ft)		2.509	3.067	3.341	3.479	3.616	3.754	3.892	4.002
BMT (ft)		92.664	77.360	69.000	65.568	62.560	59.895	58.360	56.566
KMT (ft)		95.173	80.426	72.341	69.047	66.177	63.649	62.252	60.568
BML (ft)		1141.290	1039.521	923.841	881.691	845.644	814.082	821.288	798.693
KML (ft)		1143.799	1042.587	927.182	885.170	849.260	817.836	825.180	802.695
TPI (LTons)		25.7	28.3	28.5	28.8	29.0	29.2	29.9	30.1
MTlin (ft-LTons)		334	421	428	435	442	450	480	486
CDlin (LTons)		1.3	1.8	1.7	1.7	1.6	1.6	1.8	1.8
LL (ft-FP)		133.185A	136.661A	135.283A	134.916A	134.639A	134.421A	135.853A	135.676A
W.P. AREA (ft2)		10,789	11,877	11,993	12,079	12,176	12,280	12,576	12,655
WETTED SUR. (ft2)		11,306	12,672	12,937	13,104	13,282	13,467	13,847	14,065
MAX. BEAM (ft)		62.081	62.091	62.097	62.099	62.103	62.106	62.110	62.113
LENGTN W.L. (ft)		229.513	234.917	237.660	239.031	240.354	241.626	242.949	244.740
Cb		0.4960	0.5484	0.5705	0.5807	0.5905	0.5999	0.6089	0.6158
Cm		0.7521	0.7993	0.8170	0.8251	0.8324	0.8392	0.8454	0.8501
Cp		0.6595	0.6862	0.6982	0.7038	0.7094	0.7148	0.7202	0.7244
Cmp		0.7195	0.7920	0.7997	0.8055	0.8120	0.8189	0.8387	0.8439
Cit		0.5739	0.6622	0.6758	0.6835	0.6919	0.7010	0.7210	0.7286

Assumes: Sea Water at 35.0063 ft3/LT
 Fresh Water at 35.8814 ft3/LT
 Ship floating at even keel (no heel or trim)

DFRT001A: COLL1
 274' PADDLEWHEELR

Managed Compartments:
 FOREPEAK BWH/VOID

	DISPLACEMENT LTons	DRAFT AFT ft	DRAFT FWD ft	TRIM ft	HEEL deg.	UPRIGHT GMT ft
INTACT	1,715	6.540	6.440	0.100A	0.0	42.591
DAMAGED	1,744	6.324	6.901	0.576F	0.0	41.842

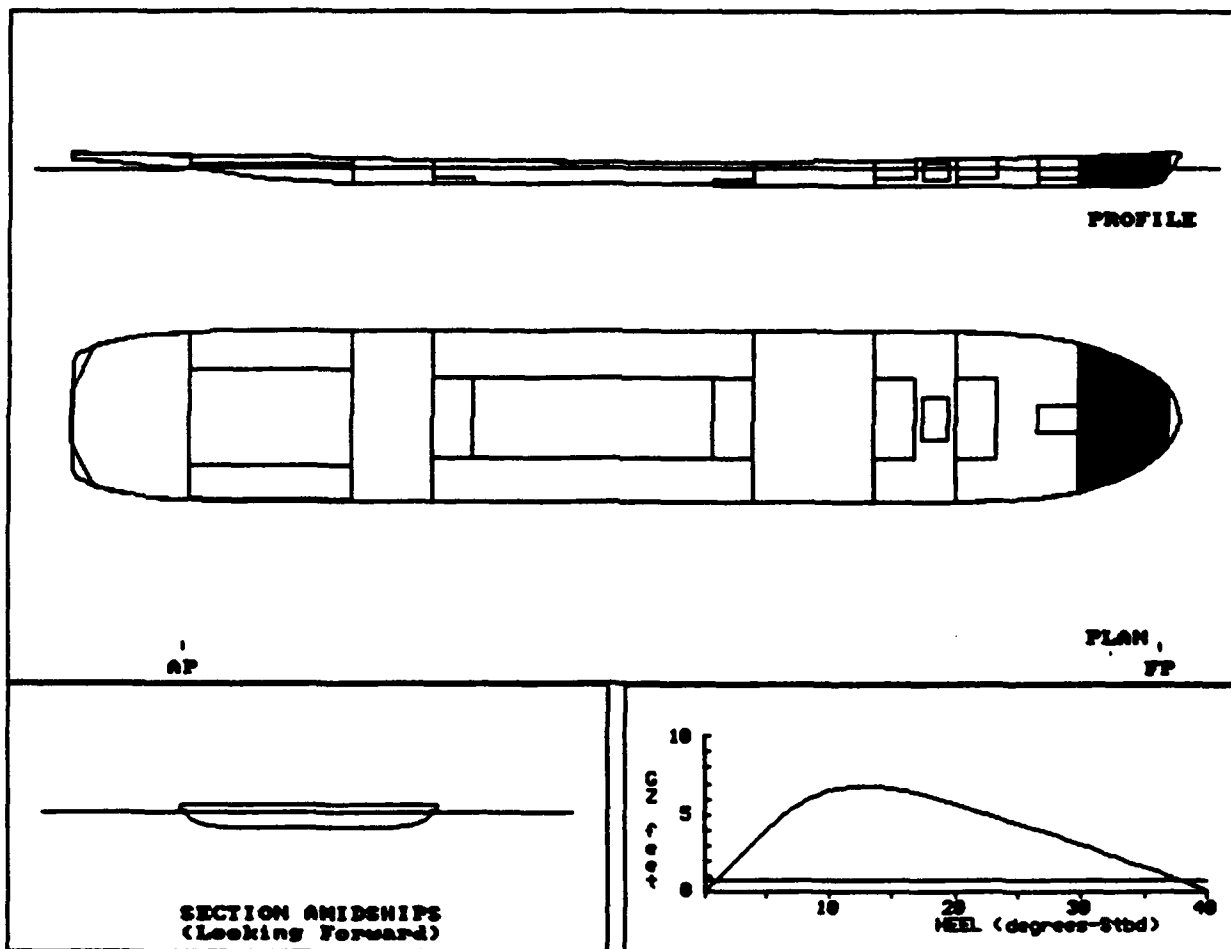

DPRT001A: COLL1
 274' PADDLEWHEELR

COMPARTMENT FLOODING SUMMARY

At 0.0o Heel	PERM.	FLOODED WTR LTons	% FULL (Damaged)	% FULL (Intact)	SP.VOL. ft3/LT	OUTFLOW LTons
FOREPEAK	0.95	9	FREE	0.0	----	----
BWTH/VOID	0.95	20	FREE	0.0	----	----
Totals		29				

INTACT DATA

Draft at AP = 6.540 ft Kmt = 62.261 ft LCG = 135.242A ft-FP
 Draft at FP = 6.440 ft VCG = 19.670 ft LCB = 135.249A ft-FP
 Displacement = 1715 LTons Gmt = 42.591 ft TCG = 0.000 ft-CL

DRAFT/GZ DATA

HEEL degrees	RIGHTING ARM ft	DRAFT AFT ft	DRAFT FWD ft	FLOODED WATER LTons
0.0	0.000	6.324	6.901	29
5.0S	3.934	6.290	6.679	28
7.0S	5.294	6.272	6.562	27
10.0S	6.507	6.256	6.628	31
20.0S	5.747	6.631	7.369	51
30.0S	3.097	7.128	8.436	62
40.0S	0.069	7.707	9.833	68

Note: Drafts are measured at A.P. and F.P along ship's centerline

JS SUMMARY (Evaluated per IMO (SOLAS'90) Rules for Passenger Ships)

	Available	Required
Static Heel Angle	0.0 deg	7.0 deg
Angle at Maximum GZ	14.0S deg	
Maximum GZ	6.858 ft	0.710 ft
Range of Positive GZ	40.0 deg	15.0 deg
Gmt (upright damaged)	41.842 ft	
Righting Area (0.0-22.0)	113.33 ft-deg	2.82 ft-deg

DPR002A: COLL1
 274' PADDLEWHEELER

Reged Compartments:

BATH/VOID VOID PUMPH1

	DISPLACEMENT LTons	DRAFT AFT ft	DRAFT FWD ft	TRIM ft	HEEL deg.	UPRIGHT GMT ft
INTACT	1,715	6.540	6.440	0.100A	0.0	42.591
DAMAGED	1,828	5.965	7.867	1.902F	0.0	42.374

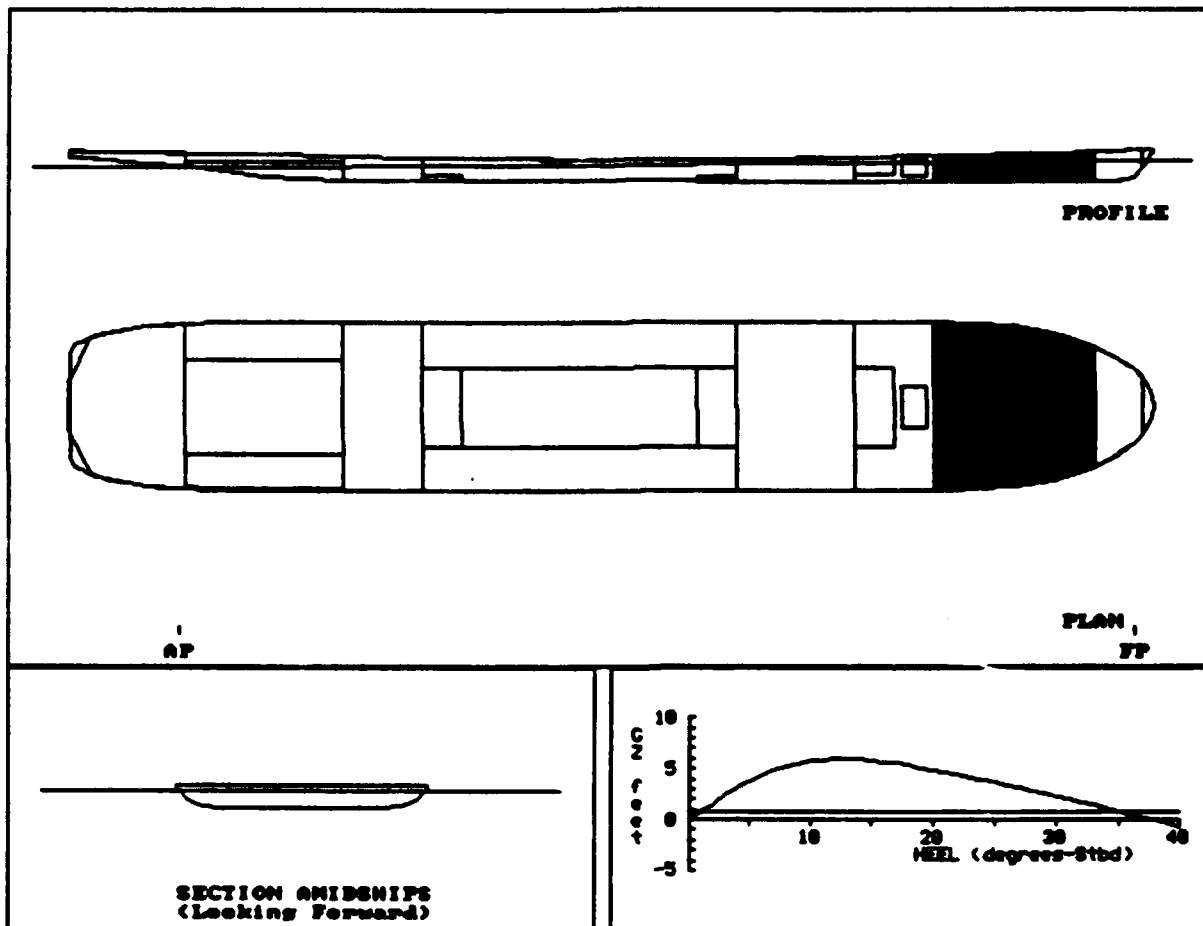

DPRT002A: COLL1
 274' PADDLEWHEELR

COMPARTMENT FLOODING SUMMARY

At 0.0o Heel	PERM.	FLOODED WTR LTons	% FULL (Damaged)	% FULL (Intact)	SP.VOL. ft3/LT	OUTFLOW LTons
BWTH/VOID	0.95	25	FREE	0.0	----	----
VOID PUMPRM1	0.95	88	FREE	0.0	----	----
Totals		113				

INTACT DATA

Draft at AP = 6.540 ft	KMT = 62.261 ft	LCG = 135.242A ft-FP
Draft at FP = 6.440 ft	VCG = 19.670 ft	LCB = 135.249A ft-FP
Displacement = 1715 LTons	GMT = 42.591 ft	TCG = 0.000 ft-CL

DRAFT/GZ DATA

HEEL degrees	RIGHTING ARM ft	DRAFT AFT ft	DRAFT FWD ft	FLOODED WATER LTons
0.0	0.000	5.965	7.867	113
5.0S	3.774	5.905	7.716	123
7.0S	4.803	5.783	7.922	139
10.0S	5.695	5.650	8.395	156
20.0S	4.884	5.495	10.380	175
30.0S	2.281	5.448	12.863	182
40.0S	-0.673	5.281	16.186	187

Note: Drafts are measured at A.P. and F.P along ship's centerline

32 SUMMARY (Evaluated per IMO (SOLAS'90) Rules for Passenger Ships)
 Available Required

Static Heel Angle	0.0 deg	7.0 deg
Angle at Maximum GZ	14.0S deg	
Maximum GZ	5.929 ft	0.710 ft
Range of Positive GZ	37.8 deg	15.0 deg
Gmt (upright damaged)	42.374 ft	
Righting Area (0.0-22.0)	99.82 ft-deg	2.82 ft-deg

DPR003A: COLL3
 274' PADDLEWHEELR

Imaged Compartments:
 VOID PUMPRM1 VOID3 TANKS

	DISPLACEMENT LTons	DRAFT AFT ft	DRAFT FWD ft	TRIM ft	HEEL deg.	UPRIGHT GMT ft
INTACT	1,715	6.540	6.440	0.100A	0.0	42.591
DAMAGED	1,921	5.760	8.655	2.895F	0.0	41.090

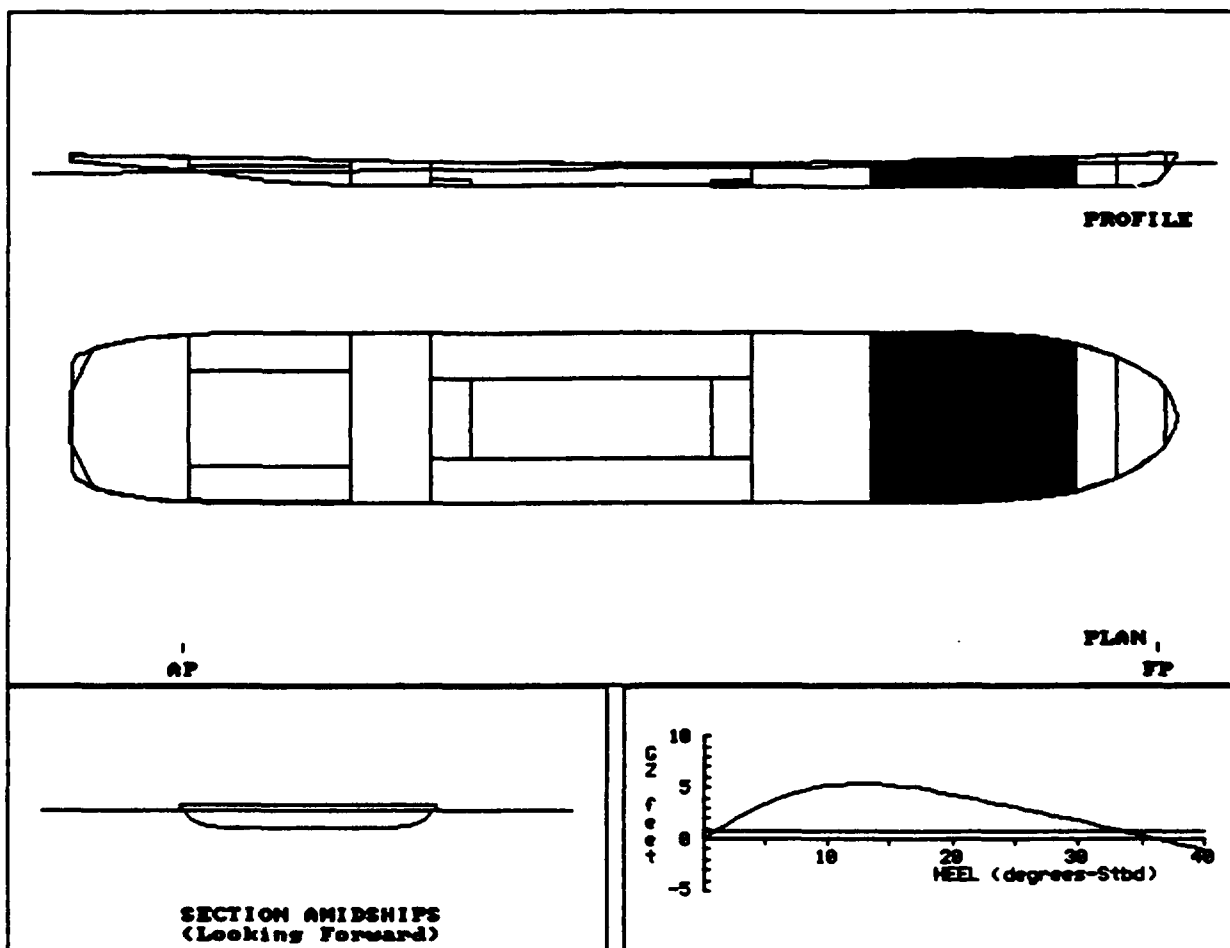

DPRT003A: COLL3
 274' PADDLEWHEELR

COMPARTMENT FLOODING SUMMARY

At 0.0o Heel	PERM.	FLOODED WTR LTons	% FULL (Damaged)	% FULL (Intact)	SP.VOL. ft ³ /LT	OUTFLOW LTons
VOID PUMPRM1	0.95	103	FREE	0.0	----	----
VOID3 TANKS	0.95	103	FREE	0.0	----	----
Totals		206				

INTACT DATA

Draft at AP = 6.540 ft	KMt = 62.261 ft	LCG = 135.242A ft-FP
Draft at FP = 6.440 ft	VCG = 19.670 ft	LCB = 135.249A ft-FP
Displacement = 1715 LTons	GMT = 42.591 ft	TCG = 0.000 ft-CL

DRAFT/GZ DATA

HEEL degrees	RIGHTING ARM ft	DRAFT AFT ft	DRAFT FWD ft	FLOODED WATER LTons
0.0	0.000	5.760	8.655	206
5.0S	3.410	5.683	8.622	228
7.0S	4.327	5.614	8.791	233
10.0S	5.164	5.535	9.236	236
20.0S	4.347	5.413	11.498	241
30.0S	1.784	5.393	14.396	243
40.0S	-1.102	5.262	18.241	247

Note: Drafts are measured at A.P. and F.P along ship's centerline

GZ SUMMARY (Evaluated per IMO (SOLAS'90) Rules for Passenger Ships)
 Available Required

Static Heel Angle	0.0 deg	7.0 deg
Angle at Maximum GZ	14.0S deg	
Maximum GZ	5.385 ft	0.710 ft
Range of Positive GZ	36.2 deg	15.0 deg
Gmt (upright damaged)	41.090 ft	
Righting Area (0.0-22.0)	90.13 ft-deg	2.82 ft-deg

DPRT004A: COLL4
 274' PADDLEWHEELR

Imaged Compartments:
 VOID3 TANKS VOID 4

	DISPLACEMENT LTons	DRAFT AFT ft	DRAFT FWD ft	TRIM ft	HEEL deg.	UPRIGHT Gmt ft
INTACT	1,715	6.540	6.440	0.100A	0.0	42.591
DAMAGED	2,144	5.998	9.556	3.558F	0.0	42.580

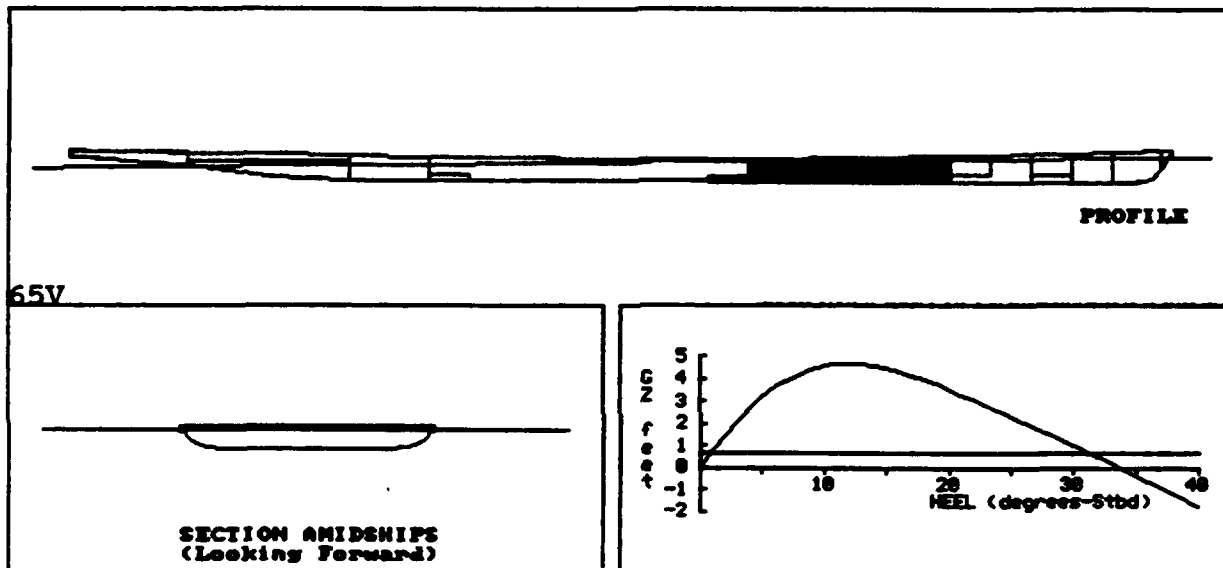

DPRT004A: COLL4
 274' PADDLEWHEELR

COMPARTMENT FLOODING SUMMARY

At 0.0o Heel	PERM.	FLOODED WTR LTons	% FULL (Damaged)	% FULL (Intact)	SP.VOL. ft ³ /LT	OUTFLOW LTons
VOID3 TANKS	0.95	121	FREE	0.0	----	----
VOID 4	0.95	307	FREE	0.0	----	----
Totals		428				

INTACT DATA

Draft at AP = 6.540 ft	Kmt = 62.261 ft	LCG = 135.242A ft-FP
Draft at FP = 6.440 ft	VCG = 19.670 ft	LCB = 135.249A ft-FP
Displacement = 1715 LTons	GMT = 42.591 ft	TCG = 0.000 ft-CL

DRAFT/GZ DATA

HEEL degrees	RIGHTING ARM ft	DRAFT AFT ft	DRAFT FWD ft	FLOODED WATER LTons
0.0	0.000	5.998	9.556	428
5.0S	3.189	6.000	9.439	412
7.0S	3.932	5.972	9.629	404
10.0S	4.559	5.969	10.136	396
20.0S	3.556	6.422	12.621	384
30.0S	1.046	7.074	15.731	378
40.0S	-1.734	7.829	19.680	374

Note: Drafts are measured at A.P. and F.P along ship's centerline

GZ SUMMARY (Evaluated per IMO (SOLAS'90) Rules for Passenger Ships)
 Available Required

Static Heel Angle	0.0 deg	7.0 deg
Angle at Maximum GZ	13.0S deg	
Maximum GZ	4.677 ft	0.710 ft
Range of Positive GZ	33.8 deg	15.0 deg
Gmt (upright damaged)	42.580 ft	
Righting Area (0.0-22.0)	78.61 ft-deg	2.82 ft-deg

COLLS
 274' PADDLEWHEELR

Managed Compartments:
 VOID 4 VOID 5

	DISPLACEMENT LTons	DRAFT AFT ft	DRAFT FWD ft	TRIM ft	HEEL deg.	UPRIGHT Gmt ft
INTACT	1,715	6.540	6.440	0.100A	0.0	42.591
DAMAGED	2,281	7.188	9.029	1.841F	5.1S	37.062

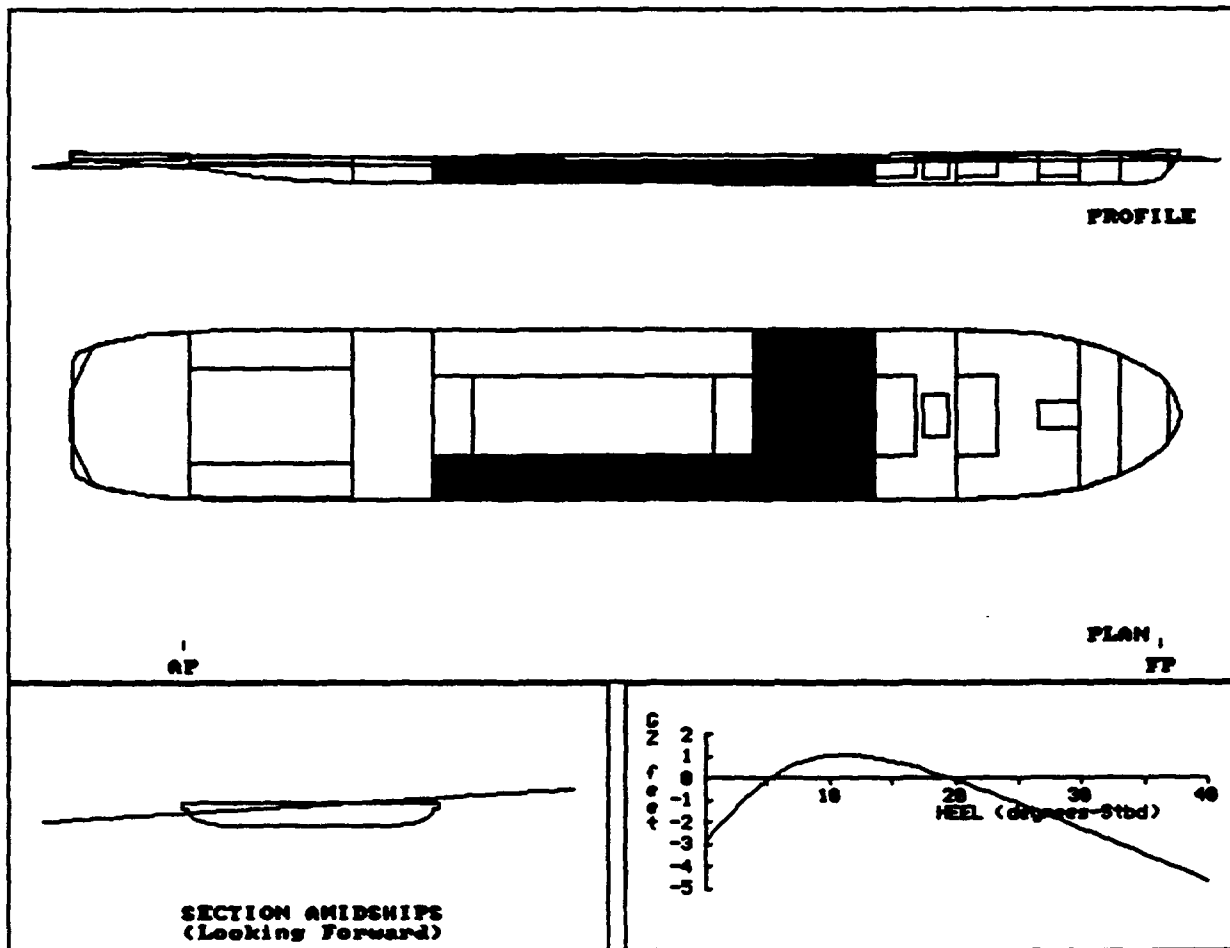

COLLS
 274' PADDLEWHEELR

COMPARTMENT FLOODING SUMMARY

At 5.1oS Heel	PERM.	FLOODED WTR LTons	% FULL (Damaged)	% FULL (Intact)	SP.VOL. ft ³ /LT	OUTFLOW LTons
VOID 4	0.95	298	FREE	0.0	----	----
VOID 5	0.95	267	FREE	0.0	----	----
Totals		566				

INTACT DATA

Draft at AP = 6.540 ft	KMt = 62.261 ft	LCG = 135.242A ft-FP
Draft at FP = 6.440 ft	VCG = 19.670 ft	LCB = 135.249A ft-FP
Displacement = 1715 LTons	GMT = 42.591 ft	TCG = 0.000 ft-CL

DRAFT/GZ DATA

HEEL degrees	RIGHTING ARM ft	DRAFT AFT ft	DRAFT FWD ft	FLOODED WATER LTons
0.0	-2.859	6.990	8.962	524
5.0S	-0.056	7.183	9.017	566
7.0S	0.622	7.263	9.203	561
10.0S	1.058	7.562	9.583	556
20.0S	-0.065	9.715	11.270	546
30.0S	-2.272	12.349	13.517	541
40.0S	-4.648	15.537	16.422	538

Note: Drafts are measured at A.P. and F.P along ship's centerline

GZ SUMMARY (Evaluated per IMO (SOLAS'90) Rules for Passenger Ships)
 Available Required

Static Heel Angle	5.1S deg	7.0 deg ✓
Angle at Maximum GZ	12.0S deg	
Maximum GZ	1.089 ft	0.710 ft
*** Range of Positive GZ	14.5 deg	15.0 deg
** Righting Area (5.1-19.7)	10.38 ft-deg	2.82 ft-deg ✓OK

*** indicates failure to meet criterion

DPRT006A: COLL6
 274' PADDLEWHEELR

Imaged Compartments:
 VOID 5 STORE ROOMS

	DISPLACEMENT LTons	DRAFT AFT ft	DRAFT FWD ft	TRIM ft	HEEL deg.	UPRIGHT Gmt ft
INTACT	1,715	6.540	6.440	0.100A	0.0	42.591
DAMAGED	2,123	8.217	6.625	1.592A	4.5S	32.010

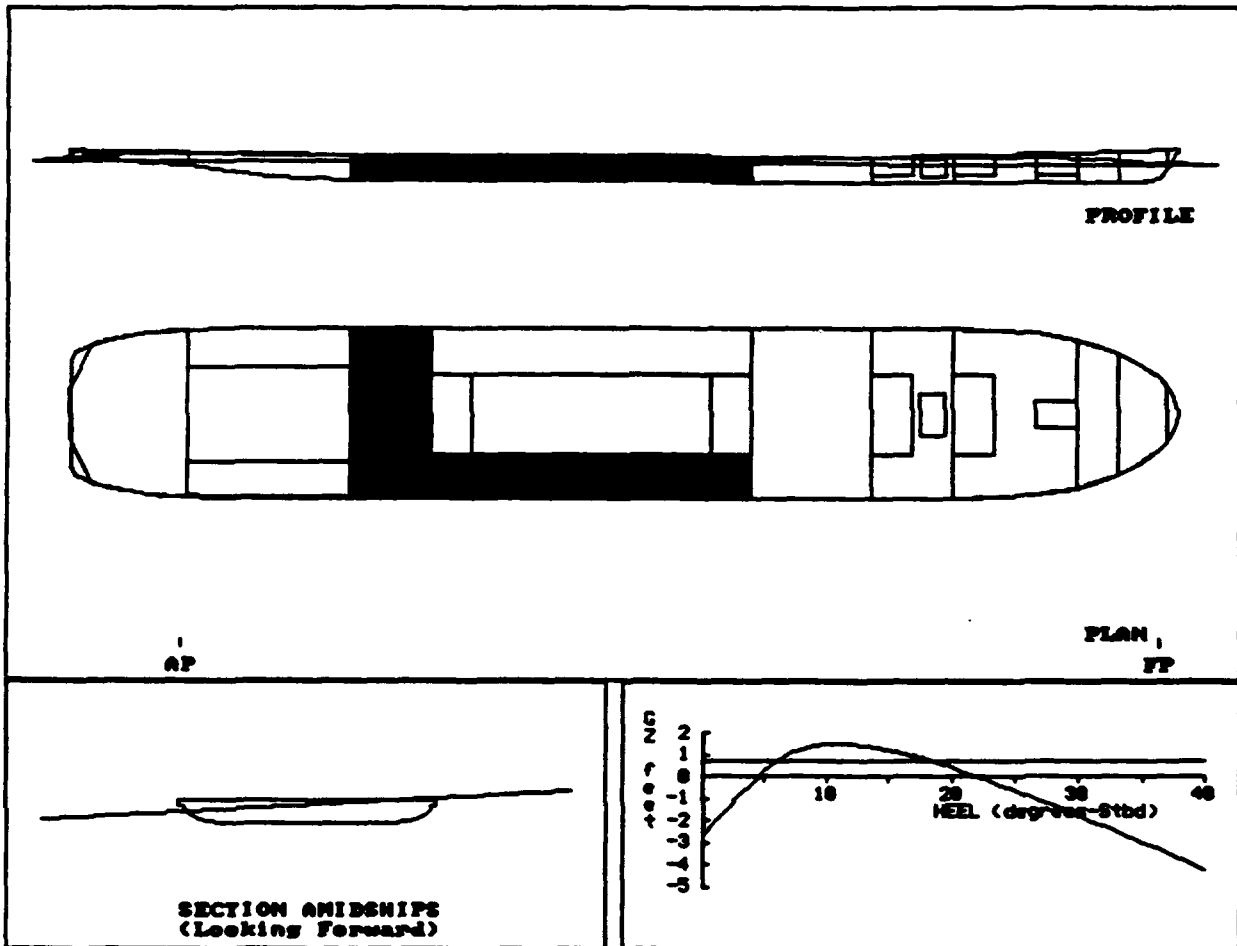

DPR007A: COLL7
 274' PADDLEWHEELR

Imaged Compartments:

STORE ROOMS VOID6 UPPER VOID6 LOWER

	DISPLACEMENT LTons	DRAFT AFT ft	DRAFT FWD ft	TRIM ft	HEEL deg.	UPRIGHT GMT ft
INTACT	1,715	6.540	6.440	0.100A	0.0	42.591
DAMAGED	1,852	7.474	6.078	1.396A	0.2S	39.173

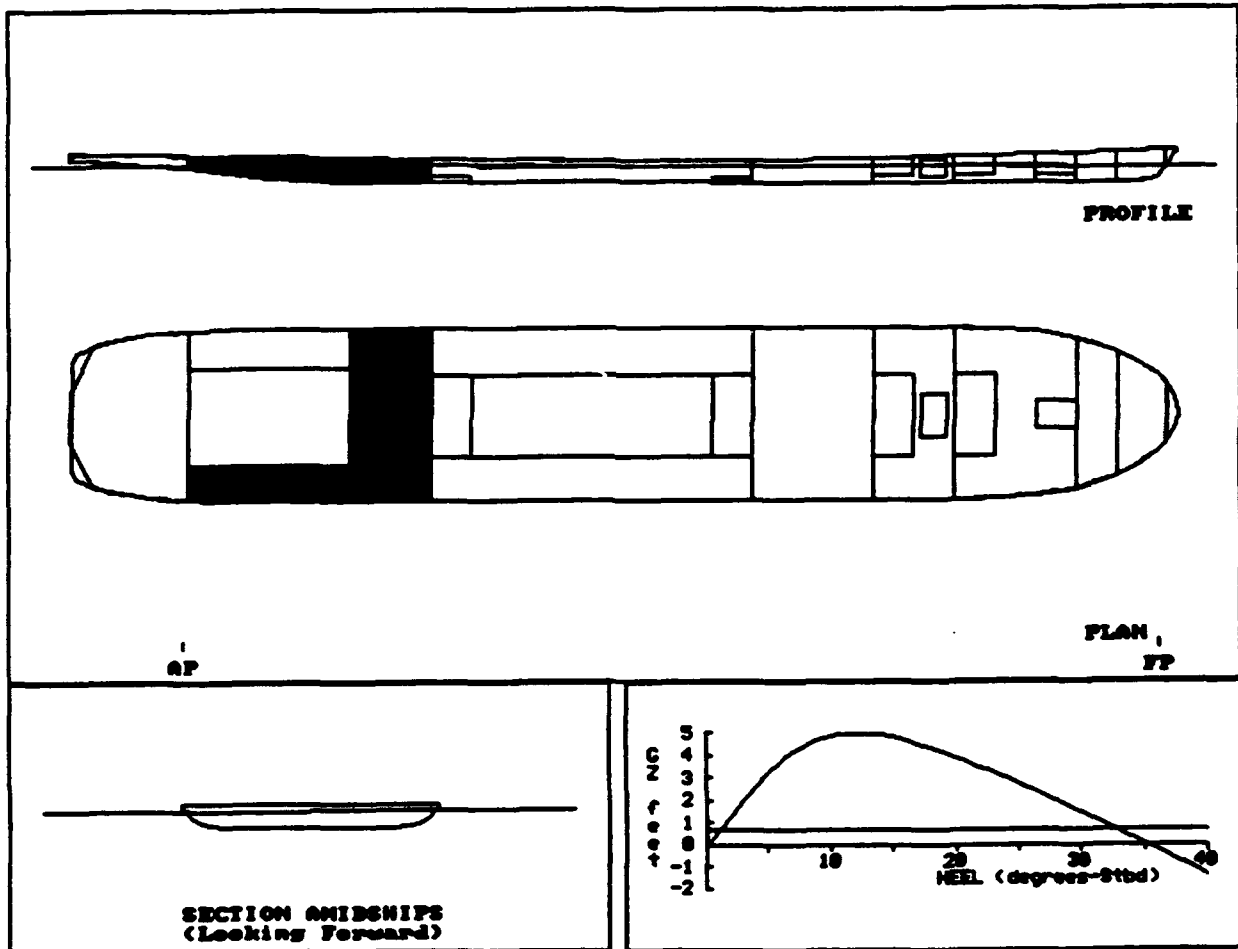

DPRT008A: COLLS
 274' PADDLEWHEEL

Damaged Compartments:

VOID6 UPPER VOID6 LOWER WHEEL BEAM

	DISPLACEMENT LTons	DRAFT AFT ft	DRAFT FWD ft	TRIM ft	HEEL deg.	UPRIGHT GMT ft
INTACT	1,715	6.540	6.440	0.100A	0.0	42.591
DAMAGED	1,723	6.600	6.407	0.193A	0.1S	40.938

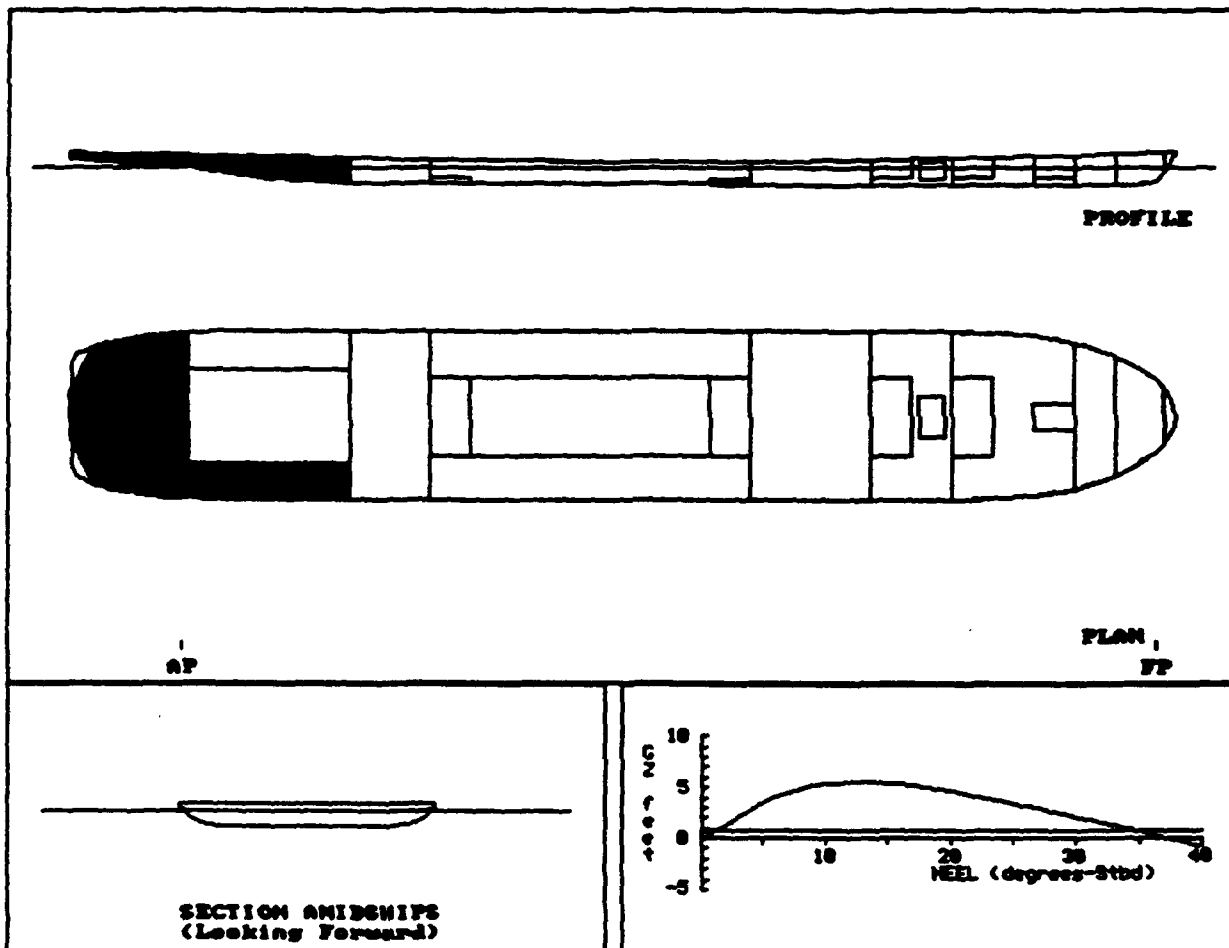

DPRT008A: COLLS
 274' PADDLEWHEELR

COMPARTMENT FLOODING SUMMARY

At 0.1oS Heel	PERM.	FLOODED WTR LTons	% FULL (Damaged)	% FULL (Intact)	SP.VOL. ft3/LT	OUTFLOW LTons
VOID6 UPPER	0.95	0	FREE	0.0	----	----
VOID6 LOWER	0.14	7	FREE	0.0	----	----
WHEEL BEAM	0.95	0	FREE	0.0	----	----
Totals		8				

INTACT DATA

Draft at AP = 6.540 ft Kmt = 62.261 ft LCG = 135.242A ft-FP
 Draft at FP = 6.440 ft VCG = 19.670 ft LCB = 135.249A ft-FP
 Displacement = 1715 LTons Gmt = 42.591 ft TCG = 0.000 ft-CL

DRAFT/GZ DATA

HEEL degrees	RIGHTING ARM ft	DRAFT AFT ft	DRAFT FWD ft	FLOODED WATER LTons
0.0	-0.104	6.596	6.414	7
5.0S	3.488	6.746	6.118	29
7.0S	4.547	6.909	5.921	50
10.0S	5.368	7.339	5.640	71
20.0S	4.627	9.223	5.029	75
30.0S	2.101	11.436	4.503	76
40.0S	-0.803	14.139	3.916	77

Note: Drafts are measured at A.P. and F.P along ship's centerline

GZ SUMMARY (Evaluated per IMO (SOLAS'90) Rules for Passenger Ships)
 Available Required

Static Heel Angle	0.1S deg	7.0 deg
Angle at Maximum GZ	14.0S deg	
Maximum GZ	5.565 ft	0.710 ft
Range of Positive GZ	37.1 deg	15.0 deg
Righting Area (0.1-22.0)	93.61 ft-deg	2.82 ft-deg

DPRT009A: COLL9
 274' PADDLEWHEELR

Imaged Compartments:

VOID6 UPPER VOID6 LOWER WHEEL BEAM PUMP RM AFT

	DISPLACEMENT LTons	DRAFT AFT ft	DRAFT FWD ft	TRIM ft	HEEL deg.	UPRIGHT Gmt ft
INTACT	1,715	6.540	6.440	0.100A	0.0	42.591
DAMAGED	1,924	8.320	5.388	2.931A	0.2S	35.293

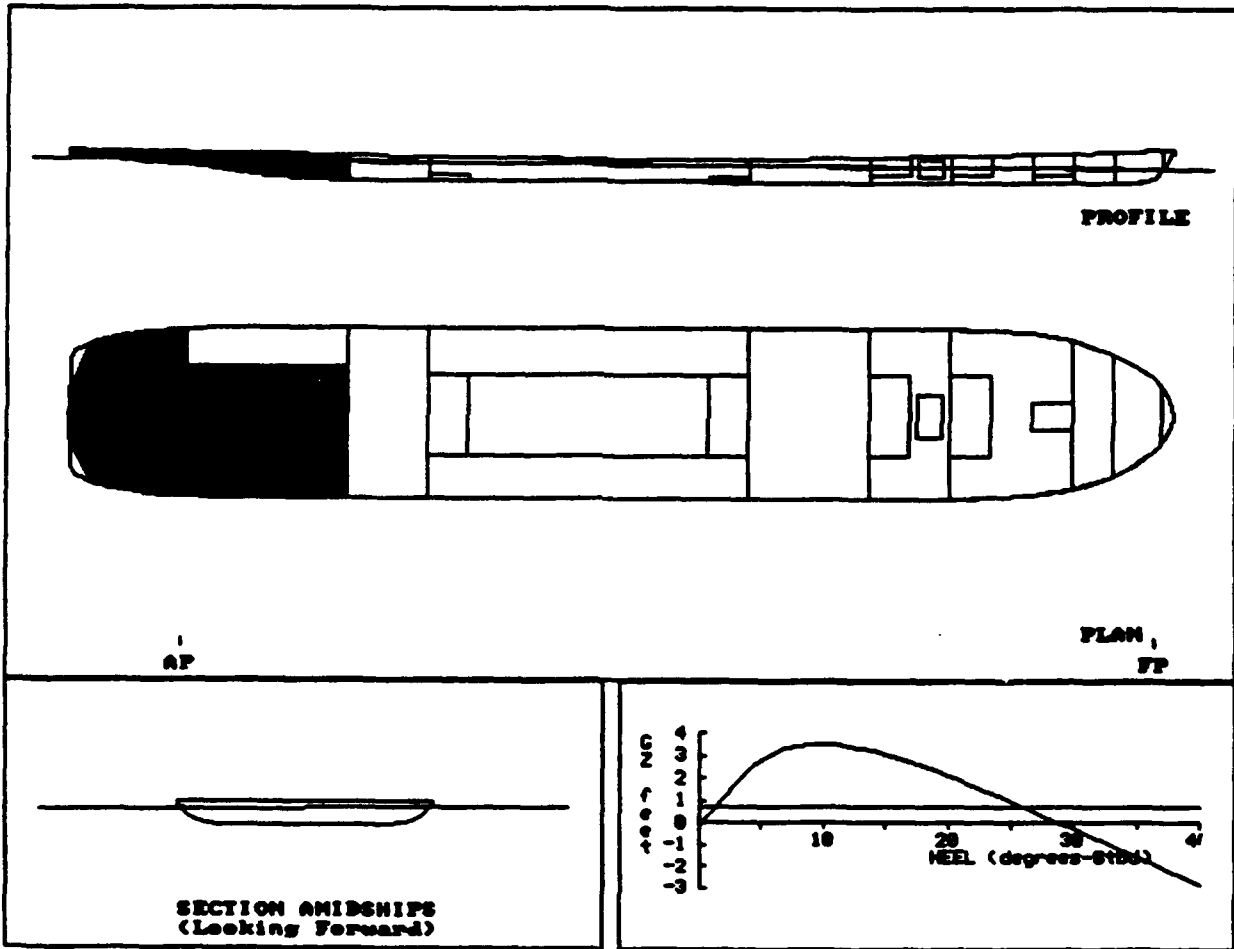

DPRT009A: COLL9
 274' PADDLEWHEELR

COMPARTMENT FLOODING SUMMARY

At 0.2oS Heel	PERM.	FLOODED WTR LTons	% FULL (Damaged)	% FULL (Intact)	SP.VOL. ft3/LT	OUTFLOW LTons
VOID6 UPPER	0.95	2	FREE	0.0	----	----
VOID6 LOWER	0.14	10	FREE	0.0	----	----
WHEEL BEAM	0.95	9	FREE	0.0	----	----
PUMP RM AFT	0.85	187	FREE	0.0	----	----
Totals		208				

INTACT DATA

Draft at AP = 6.540 ft	KMt = 62.261 ft	LCG = 135.242A ft-FP
Draft at FP = 6.440 ft	VCG = 19.670 ft	LCB = 135.249A ft-FP
Displacement = 1715 LTons	Gmt = 42.591 ft	TCG = 0.000 ft-CL

DRAFT/GZ DATA

HEEL degrees	RIGHTING ARM ft	DRAFT AFT ft	DRAFT FWD ft	FLOODED WATER LTons
0.0	-0.160	8.301	5.407	206
5.0S	2.788	8.810	4.964	269
7.0S	3.312	9.390	4.594	292
10.0S	3.517	10.554	4.015	313
20.0S	2.143	15.678	1.992	348
30.0S	-0.269	21.765	-0.144	363
40.0S	-2.833	28.598	-2.455	357

Note: Drafts are measured at A.P. and F.P along ship's centerline

GZ SUMMARY (Evaluated per IMO (SOLAS'90) Rules for Passenger Ships)
 Available Required

Static Heel Angle	0.2S deg	7.0 deg
Angle at Maximum GZ	11.0S deg	
Maximum GZ	3.517 ft	0.710 ft
Range of Positive GZ	28.7 deg	15.0 deg
Righting Area (0.2-22.0)	57.49 ft-deg	2.82 ft-deg

DPR010A: GROUND1
 274' PADDLEWHEELR

Managed Compartments:

BWTH/VOID VOID PURPRN1 COFFERDAM 1

	DISPLACEMENT LTons	DRAFT AFT ft	DRAFT FWD ft	TRIM ft	HEEL deg.	UPRIGHT GMT ft
INTACT	1,715	6.540	6.440	0.100A	0.0	42.591
DAMAGED	1,837	5.918	7.976	2.058F	0.0	42.795

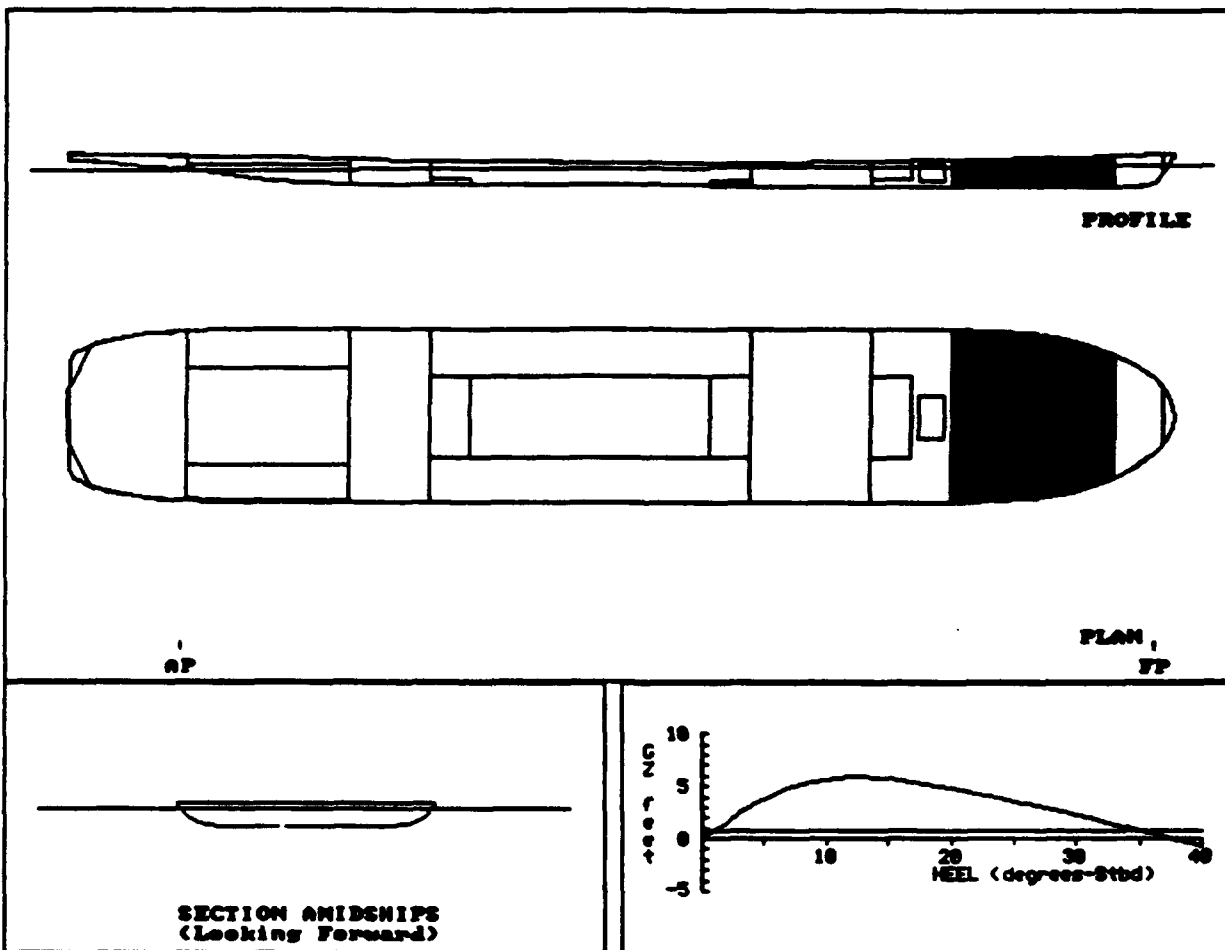

DPR010A: GROUND1
 274' PADDLEWHEELR

COMPARTMENT FLOODING SUMMARY

At 0.0o Heel	PERM.	FLOODED WTR LTons	% FULL (Damaged)	% FULL (Intact)	SP.VOL. ft3/LT	OUTFLOW LTons
BWTH/VOID	0.95	25	FREE	0.0	----	----
VOID PUMPRM1	0.95	90	FREE	0.0	----	----
COFFERDAM 1	0.95	6	FREE	0.0	----	----
Totals		121				

INTACT DATA

Draft at AP = 6.540 ft	KMT = 62.261 ft	LCG = 135.242A ft-FP
Draft at FP = 6.440 ft	VCG = 19.670 ft	LCB = 135.249A ft-FP
Displacement = 1715 LTons	GMT = 42.591 ft	TCG = 0.000 ft-CL

DRAFT/GZ DATA

HEEL degrees	RIGHTING ARM ft	DRAFT AFT ft	DRAFT FWD ft	FLOODED WATER LTons
0.0	0.000	5.918	7.976	121
5.0S	3.768	5.857	7.832	133
7.0S	4.782	5.735	8.047	149
10.0S	5.669	5.602	8.529	165
20.0S	4.856	5.393	10.624	183
30.0S	2.253	5.277	13.259	190
40.0S	-0.697	5.021	16.787	196

Note: Drafts are measured at A.P. and F.P along ship's centerline

GZ SUMMARY (Evaluated per IMO (SOLAS'90) Rules for Passenger Ships)

	Available	Required
Static Heel Angle	0.0 deg	7.0 deg
Angle at Maximum GZ	14.0S deg	
Maximum GZ	5.903 ft	0.710 ft
Range of Positive GZ	37.7 deg	15.0 deg
Gmt (upright damaged)	42.795 ft	
Righting Area (0.0-22.0)	99.41 ft-deg	2.82 ft-deg

DPR011A: GROUND2
 274' PADDLEWHEEL

Imaged Compartments:

VOID 4 VOID 5 CROSSFLD FLD THEATRE STOR

	DISPLACEMENT LTons	DRAFT AFT ft	DRAFT FWD ft	TRIM ft	HEEL deg.	UPRIGHT GMT ft
INTACT	1,715	6.540	6.440	0.100A	0.0	42.591
DAMAGED	2,648	8.093	9.804	1.712F	>90.0S	39.153

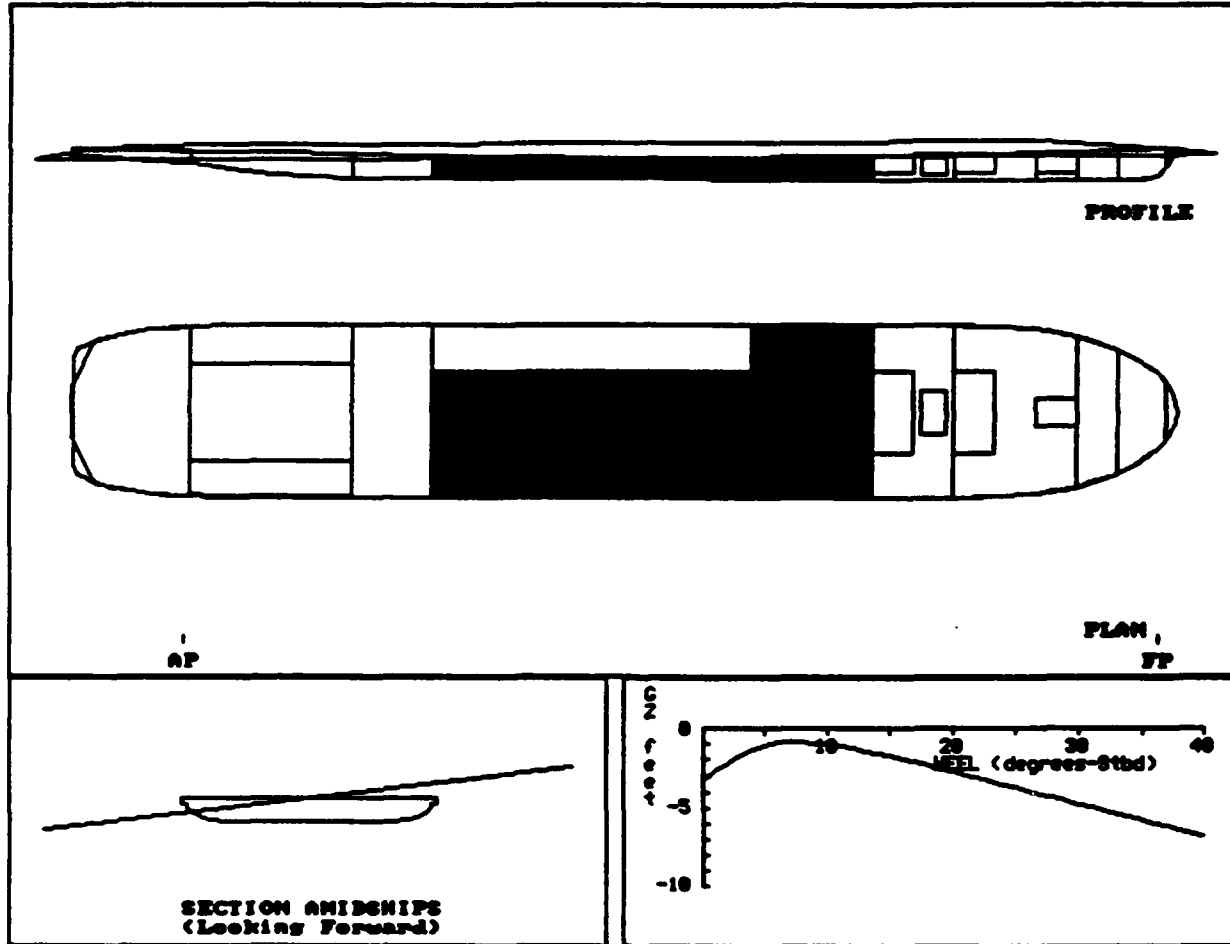

DPRT011A: GROUND2
 274' PADDLEWHEELR

COMPARTMENT FLOODING SUMMARY

At >90oS Heel	PERM.	FLOODED WTR LTons	% FULL (Damaged)	% FULL (Intact)	SP.VOL. ft ³ /LT	OUTFLOW LTons
VOID 4	0.95	353	FREE	0.0	----	----
VOID 5	0.95	254	FREE	0.0	----	----
CROSSFLD FWD	0.95	15	FREE	0.0	----	----
THEATRE STOR	0.60	310	FREE	0.0	----	----
Totals		933				

INTACT DATA

Draft at AP = 6.540 ft Kmt = 62.261 ft LCG = 135.242A ft-FP
 Draft at FP = 6.440 ft VCG = 19.670 ft LCB = 135.249A ft-FP
 Displacement = 1715 LTons GMT = 42.591 ft TCG = 0.000 ft-CL

DRAFT/GZ DATA

HEEL degrees	RIGHTING ARM ft	DRAFT AFT ft	DRAFT FWD ft	FLOODED WATER LTons
0.0	-3.347	8.093	9.804	933
5.0S	-1.025	8.345	10.507	929
7.0S	-0.824	8.576	11.004	926
10.0S	-1.007	9.214	11.809	925
20.0S	-2.713	12.399	15.040	927
30.0S	-4.768	16.561	18.977	927
40.0S	-6.833	21.621	24.114	926

Note: Drafts are measured at A.P. and F.P along ship's centerline

GZ SUMMARY (Evaluated per IMO (SOLAS'90) Rules for Passenger Ships)
 Available Required

*** Static Heel Angle	>90.0S deg	7.0 deg
Angle at Maximum GZ	8.0S deg	
*** Maximum GZ	-0.824 ft	0.710 ft
*** Range of Positive GZ	0.0 deg	15.0 deg
*** Righting Area (%0.0- 0.0)	0.00 ft-deg	2.82 ft-deg

*** indicates failure to meet criterion

DPRT012A: GROUND3
 274' PADDLEWHEELR

Imaged Compartments:

VOID 4 CROSSFLD FWD THEATRE STOR

	DISPLACEMENT LTONS	DRAFT AFT ft	DRAFT FWD ft	TRIM ft	HEEL deg.	UPRIGHT GMT ft
INTACT	1,715	6.540	6.440	0.100A	0.0	42.591
DAMAGED	2,326	7.158	9.219	2.061F	0.0	50.272

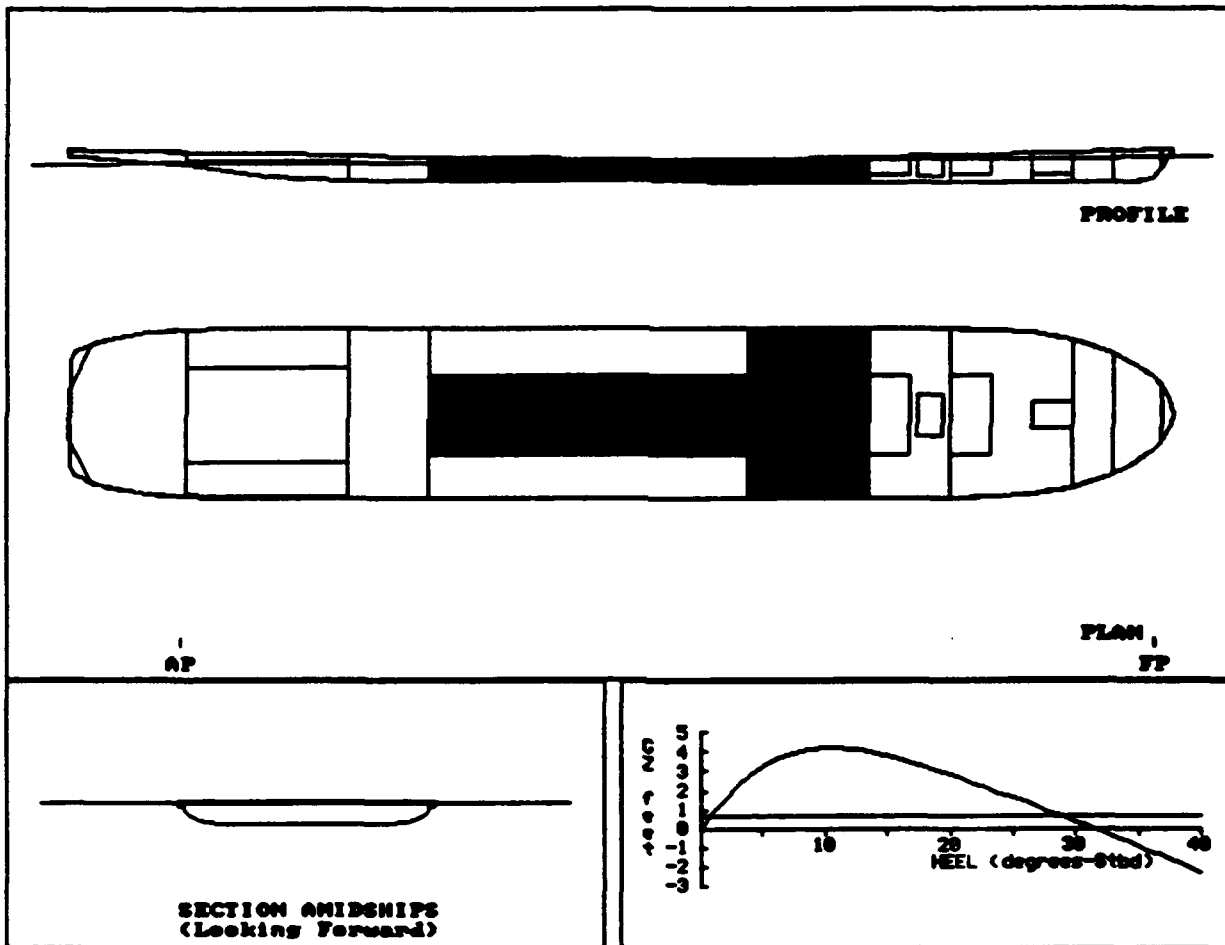

DPRT012A: GROUND3
 274' PADDLEWHEELR

COMPARTMENT FLOODING SUMMARY

At 0.0o Heel	PERM.	FLOODED WTR LTons	% FULL (Damaged)	% FULL (Intact)	SP.VOL. ft3/LT	OUTFLOW LTons
VOID 4	0.95	317	FREE	0.0	----	----
CROSSFLD FWD	0.95	15	FREE	0.0	----	----
THEATRE STOR	0.60	278	FREE	0.0	----	----
Totals		610				

INTACT DATA

Draft at AP = 6.540 ft Kmt = 62.261 ft LCG = 135.242A ft-FP
 Draft at FP = 6.440 ft VCG = 19.670 ft LCB = 135.249A ft-FP
 Displacement = 1715 LTons GMT = 42.591 ft TCG = 0.000 ft-CL

DRAFT/GZ DATA

HEEL degrees	RIGHTING ARM ft	DRAFT AFT ft	DRAFT FWD ft	FLOODED WATER LTons
0.0	0.000	7.158	9.219	610
5.0S	3.276	7.191	9.229	597
7.0S	3.872	7.267	9.473	594
10.0S	4.207	7.579	9.936	592
20.0S	2.840	9.866	11.958	597
30.0S	0.397	12.685	14.611	600
40.0S	-2.275	16.102	18.001	600

Note: Drafts are measured at A.P. and F.P along ship's centerline

GZ SUMMARY (Evaluated per IMO (SOLAS'90) Rules for Passenger Ships)
 Available Required

Static Heel Angle	0.0 deg	7.0 deg
Angle at Maximum GZ	12.0S deg	
Maximum GZ	4.211 ft	0.710 ft
Range of Positive GZ	31.5 deg	15.0 deg
Gmt (upright damaged)	50.272 ft	
Righting Area (0.0-22.0)	71.09 ft-deg	2.82 ft-deg

DPR013A: GROUND4
 274' PADDLEWHEELER

Damaged Compartments:

THEATRE STOR CROSSFLD AFT STORE ROOMS

	DISPLACEMENT LTons	DRAFT AFT ft	DRAFT FWD ft	TRIM ft	HEEL deg.	UPRIGHT GMT ft
INTACT	1,715	6.540	6.440	0.100A	0.0	42.591
DAMAGED	2,138	8.329	6.730	1.599A	0.0	44.678

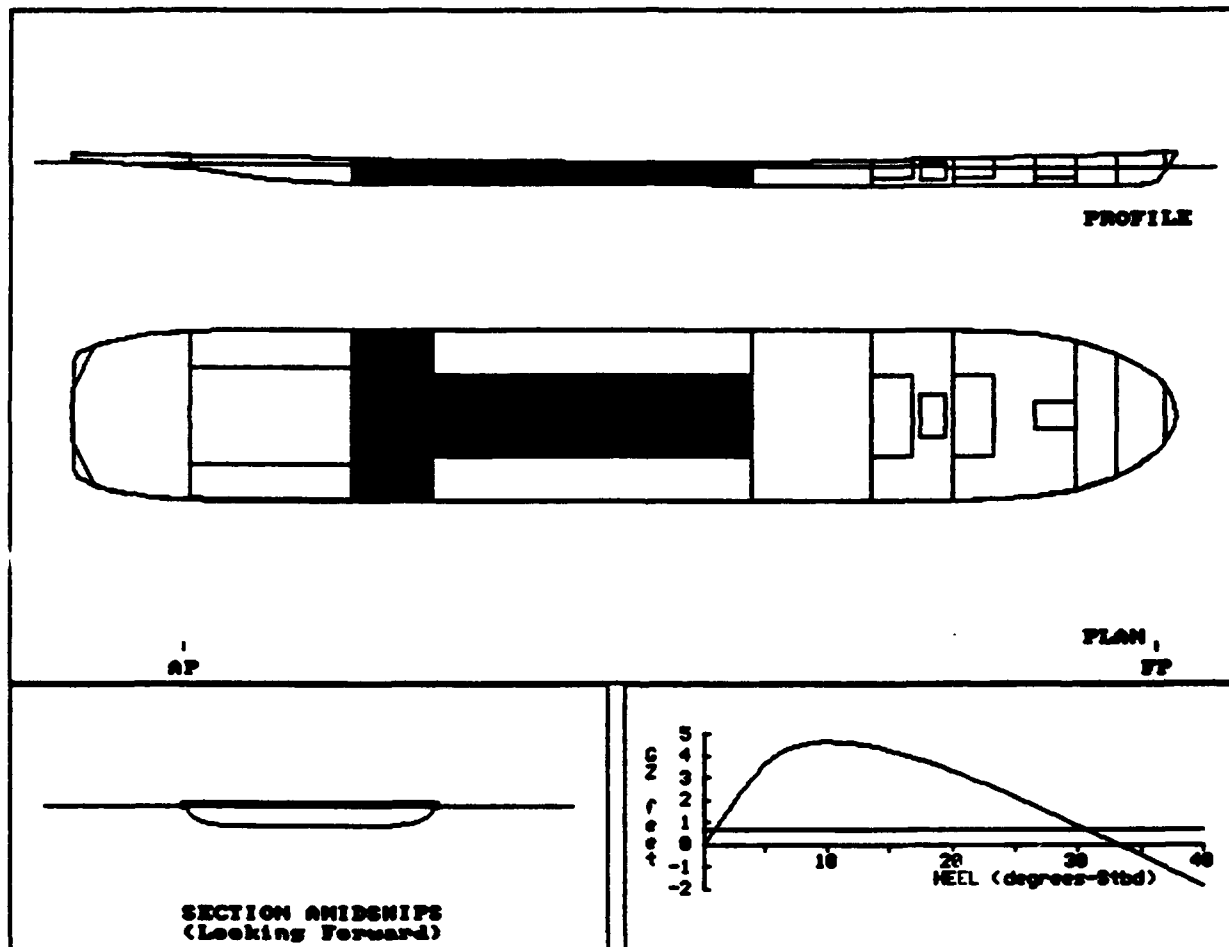

DPRT013A: GROUND4
 274' PADDLEWHEEL

COMPARTMENT FLOODING SUMMARY

At 0.0o Heel	PERM.	FLOODED WTR LTons	% FULL (Damaged)	% FULL (Intact)	SP.VOL. ft3/LT	OUTFLOW LTons
THEATRE STOR	0.60	263	FREE	0.0	----	----
CROSSFLD APT	0.95	15	FREE	0.0	----	----
STORE ROOMS	0.60	145	FREE	0.0	----	----
Totals		423				

INTACT DATA

Draft at AP = 6.540 ft KMT = 62.261 ft LCG = 135.242A ft-FP
 Draft at FP = 6.440 ft VCG = 19.670 ft LCB = 135.249A ft-FP
 Displacement = 1715 LTons GMT = 42.591 ft TCG = 0.000 ft-CL

DRAFT/GZ DATA

HEEL degrees	RIGHTING ARM ft	DRAFT APT ft	DRAFT FWD ft	FLOODED WATER LTons
0.0	0.000	8.329	6.730	423
5.0S	3.602	8.333	6.570	419
7.0S	4.332	8.524	6.547	421
10.0S	4.643	9.246	6.414	427
20.0S	3.330	12.945	6.109	442
30.0S	0.882	17.522	5.921	449
40.0S	-1.842	23.096	5.789	452

Note: Drafts are measured at A.P. and F.P along ship's centerline

GZ SUMMARY (Evaluated per IMO (SOLAS'90) Rules for Passenger Ships)
 Available Required

Static Heel Angle	0.0 deg	7.0 deg
Angle at Maximum GZ	11.0S deg	
Maximum GZ	4.643 ft	0.710 ft
Range of Positive GZ	33.3 deg	15.0 deg
Gmt (upright damaged)	44.678 ft	
Righting Area (0.0-22.0)	79.13 ft-deg	2.82 ft-deg

DEPT014A: GROUND5
 274' PADDLEWHEELR

Imaged Compartments:

THEATRE STOR CROSSFLD AFT STORE ROOMS VOID 5

	DISPLACEMENT LTons	DRAFT AFT ft	DRAFT FWD ft	TRIM ft	HEEL deg.	UPRIGHT GMT ft
INTACT	1,715	6.540	6.440	0.100A	0.0	42.591
DAMAGED	2,426	9.207	7.278	1.929A	>90.0S	38.659

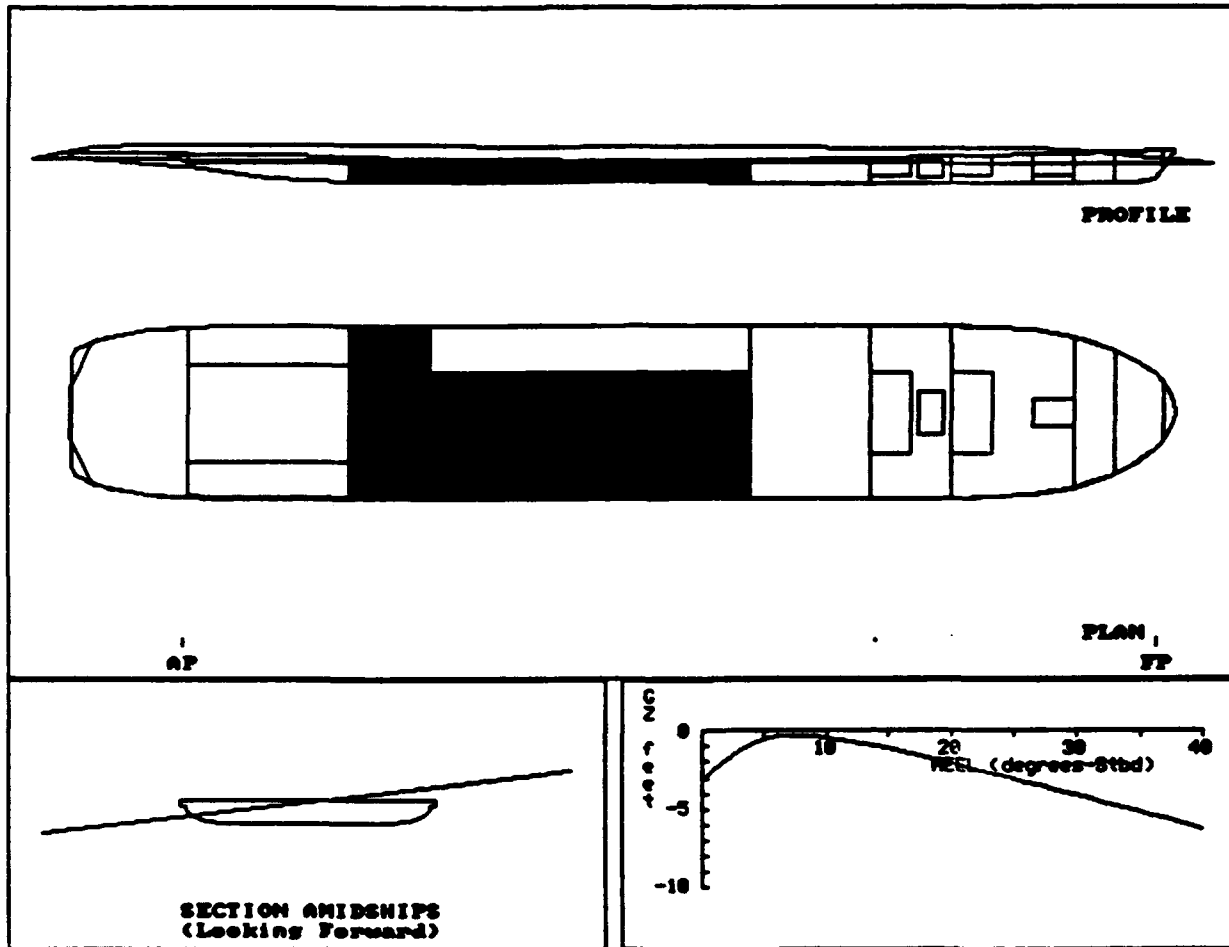

DPRT014A: GROUND5
 274' PADDLEWHEELR

COMPARTMENT FLOODING SUMMARY

At >90oS Heel	PERM.	FLOODED WTR LTons	% FULL (Damaged)	% FULL (Intact)	SP.VOL. ft3/LT	OUTFLOW LTons
THEATRE STOR	0.60	293	FREE	0.0	----	----
CROSSFLD AFT	0.95	15	FREE	0.0	----	----
STORE ROOMS	0.60	162	FREE	0.0	----	----
VOID 5	0.95	240	FREE	0.0	----	----
Totals		711				

INTACT DATA

Draft at AP = 6.540 ft KMT = 62.261 ft LCG = 135.242A ft-FP
 Draft at FP = 6.440 ft VCG = 19.670 ft LCB = 135.249A ft-FP
 Displacement = 1715 LTons GMT = 42.591 ft TCG = 0.000 ft-CL

DRAFT/GZ DATA

HEEL degrees	RIGHTING ARM ft	DRAFT AFT ft	DRAFT FWD ft	FLOODED WATER LTons
0.0	-3.144	9.207	7.278	711
5.0S	-0.521	9.706	7.264	745
7.0S	-0.335	10.331	7.175	748
10.0S	-0.457	11.496	7.097	752
20.0S	-2.057	16.437	7.100	762
30.0S	-4.112	22.295	7.523	765
40.0S	-6.232	29.616	8.123	766

Note: Drafts are measured at A.P. and F.P along ship's centerline

GZ SUMMARY (Evaluated per IMO (SOLAS'90) Rules for Passenger Ships)
 Available Required

*** Static Heel Angle	>90.0S deg	7.0 deg
Angle at Maximum GZ	8.0S deg	
*** Maximum GZ	-0.335 ft	0.710 ft
*** Range of Positive GZ	0.0 deg	15.0 deg
*** Righting Area (%0.0- 0.0)	0.00 ft-deg	2.02 ft-deg

*** indicates failure to meet criterion

DERT015A: GROUND6
 274' PADDLEWHEELR

Seaged Compartments:

STORE ROOMS VOID6 UPPER VOID6 LOWER PUMP RM AFT

	DISPLACEMENT LTons	DRAFT AFT ft	DRAFT FWD ft	TRIM ft	HEEL deg.	UPRIGHT GMT ft
INTACT	1,715	6.540	6.440	0.100A	0.0	42.591
DAMAGED	2,132	9.653	4.851	4.803A	0.6S	37.970

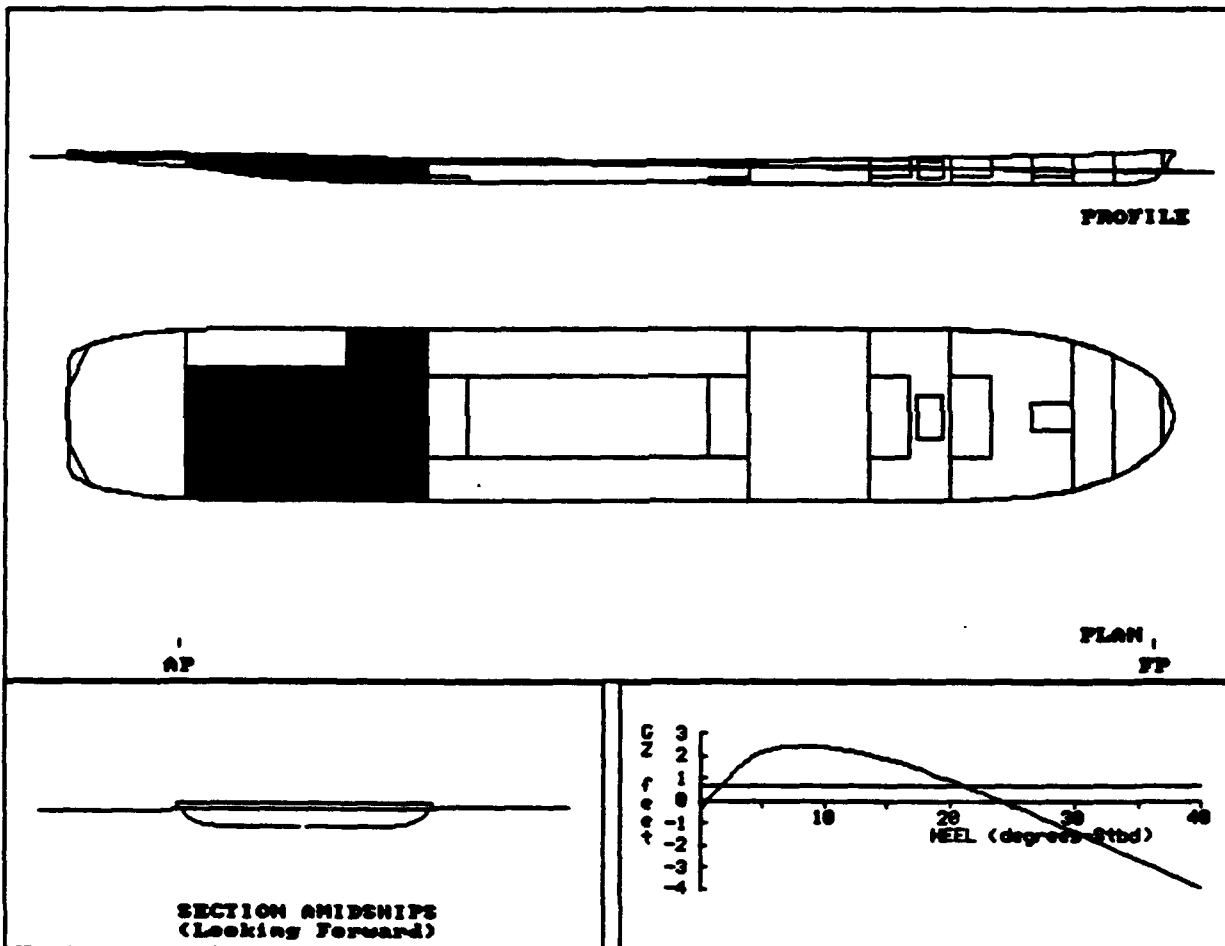

DPRT015A: GROUND6
 274' PADDLEWHEELR

COMPARTMENT FLOODING SUMMARY

At 0.6oS Heel	PERM.	FLOODED WTR LTons	% FULL (Damaged)	% FULL (Intact)	SP.VOL. ft3/LT	OUTFLOW LTons
STORE ROOMS	0.60	158	FREE	0.0	----	----
VOID6 UPPER	0.95	21	FREE	0.0	----	----
VOID6 LOWER	0.14	10	FREE	0.0	----	----
PUMP RM AFT	0.85	227	FREE	0.0	----	----
Totals		416				

INTACT DATA

Draft at AP = 6.540 ft Kmt = 62.261 ft LCG = 135.242A ft-FP
 Draft at FP = 6.440 ft VCG = 19.670 ft LCB = 135.249A ft-FP
 Displacement = 1715 LTons Gmt = 42.591 ft TCG = 0.000 ft-CL

DRAFT/GZ DATA

HEEL degrees	RIGHTING ARM ft	DRAFT AFT ft	DRAFT FWD ft	FLOODED WATER LTons
0.0	-0.383	9.589	4.897	410
5.0S	2.187	10.312	4.427	453
7.0S	2.434	11.088	4.041	464
10.0S	2.412	12.485	3.442	475
20.0S	0.937	17.912	1.572	487
30.0S	-1.354	24.378	-0.396	486
40.0S	-3.904	32.731	-2.997	488

Note: Drafts are measured at A.P. and F.P along ship's centerline

GZ SUMMARY (Evaluated per IMO (SOLAS'90) Rules for Passenger Ships)
 Available Required

Static Heel Angle	0.6S deg	7.0 deg
Angle at Maximum GZ	9.0S deg	
Maximum GZ	2.460 ft	0.710 ft
Range of Positive GZ	23.7 deg	15.0 deg
Righting Area (0.6-22.0)	36.93 ft-deg	2.82 ft-deg

RTRN001B: COLL1
 274' PADDLEWHEELR

Used Compartments:
 FOREPEAK BATH/VOID

	DISPLACEMENT LTons	DRAFT AFT ft	DRAFT FWD ft	TRIM ft	HEEL deg.	UPRIGHT GMT ft
INTACT	1,644	6.790	5.660	1.130A	0.0	43.596
DAMAGED	1,667	6.609	6.046	0.563A	0.0	43.326

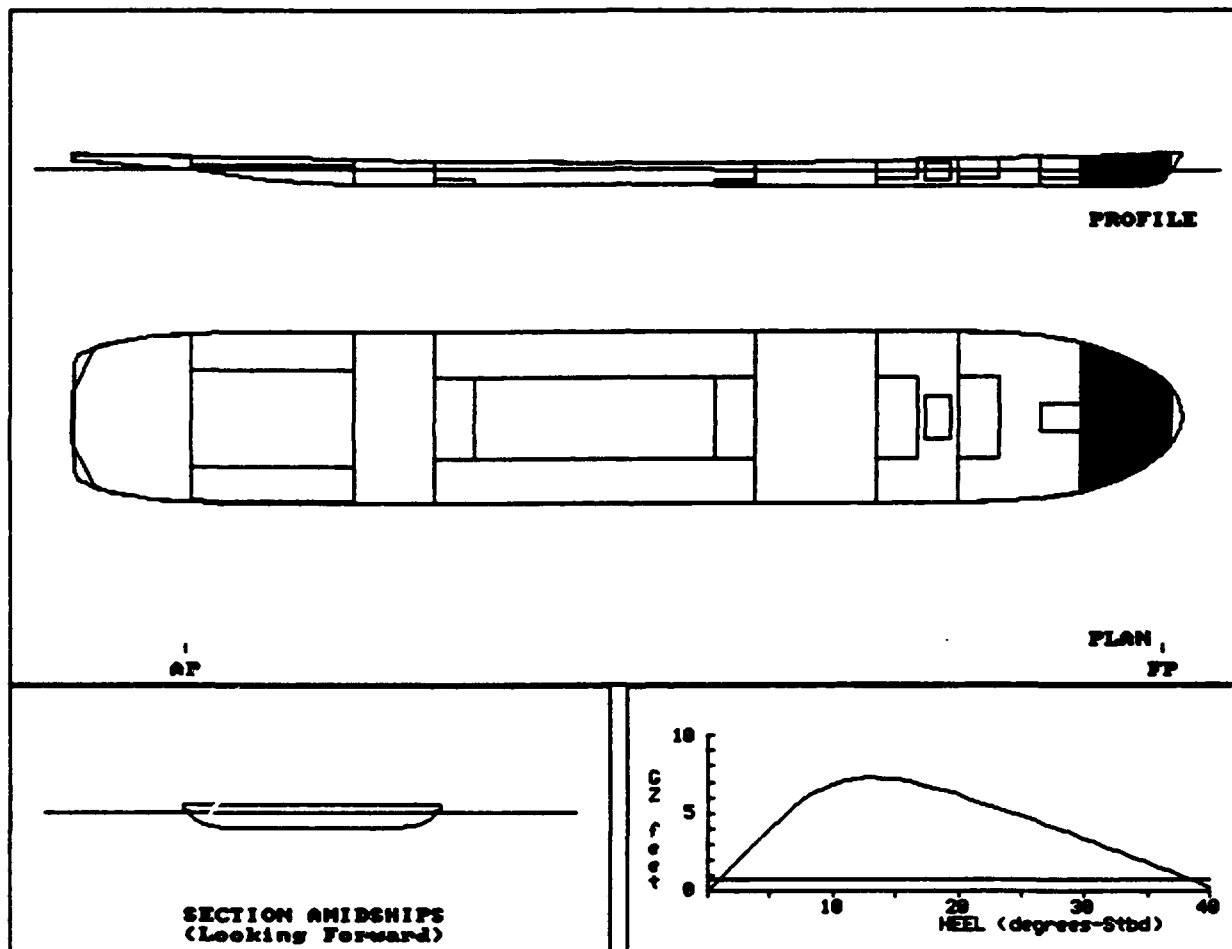

RTRN001B: COLL1
 274' PADDLEWHEELR

COMPARTMENT FLOODING SUMMARY

At 0.0o Heel	PERM.	FLOODED WTR LTons	% FULL (Damaged)	% FULL (Intact)	SP.VOL. ft3/LT	OUTFLOW LTons
FOREPEAK	0.95	7	FREE	0.0	----	----
BWTH/VOID	0.95	16	FREE	0.0	----	----
Totals		23				

INTACT DATA

Draft at AP = 6.790 ft KMT = 63.786 ft LCG = 138.723A ft-FP
 Draft at FP = 5.660 ft VCG = 20.190 ft LCB = 138.799A ft-FP
 Displacement = 1644 LTons GMT = 43.596 ft TCG = 0.000 ft-CL

DRAFT/GZ DATA

HEEL degrees	RIGHTING ARM ft	DRAFT AFT ft	DRAFT FWD ft	FLOODED WATER LTons
0.0	0.000	6.609	6.046	23
5.0S	3.971	6.549	5.886	22
7.0S	5.456	6.503	5.766	21
10.0S	6.828	6.556	5.636	22
20.0S	6.133	7.238	5.581	34
30.0S	3.390	8.057	5.746	43
40.0S	0.237	9.035	6.026	49

Note: Drafts are measured at A.P. and F.P along ship's centerline

GZ SUMMARY (Evaluated per IMO (SOLAS'90) Rules for Passenger Ships)
 Available Required

Static Heel Angle	0.0 deg	7.0 deg
Angle at Maximum GZ	14.0S deg	
Maximum GZ	7.255 ft	0.710 ft
Range of Positive GZ	40.0 deg	15.0 deg
Gmt (upright damaged)	43.326 ft	
Righting Area (0.0-22.0)	118.99 ft-deg	2.82 ft-deg

RTRN002B: COLL1
 274' PADDLEWHEELR

Imaged Compartments:

BWTH/VOID VOID PUMP/1

	DISPLACEMENT LTons	DRAFT AFT ft	DRAFT FWD ft	TRIM ft	HEEL deg.	UPRIGHT GMT ft
INTACT	1,644	6.790	5.660	1.130A	0.0	43.596
DAMAGED	1,737	6.312	6.870	0.558F	0.0	42.108

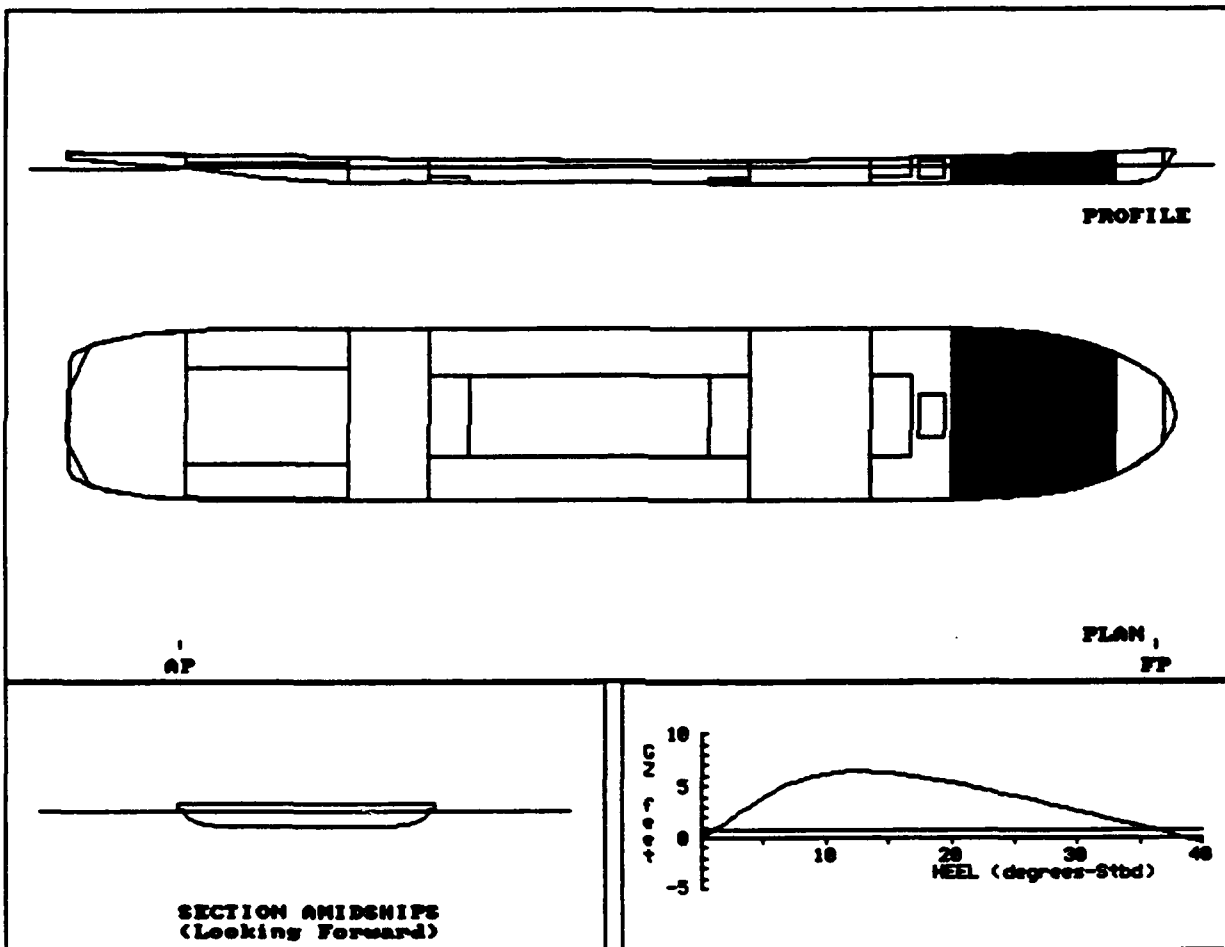

RTRN002B: COLL1
 274' PADDLEWHEELR

COMPARTMENT FLOODING SUMMARY

At 0.0o Heel	PERM.	FLOODED WTR LTons	% FULL (Damaged)	% FULL (Intact)	SP.VOL. ft3/LT	OUTFLOW LTons
BWTH/VOID	0.95	20	FREE	0.0	----	----
VOID PUMPRM1	0.95	73	FREE	0.0	----	----
Totals		92				

INTACT DATA

Draft at AP = 6.790 ft KMT = 63.786 ft LCG = 138.723A ft-FP
 Draft at FP = 5.660 ft VCG = 20.190 ft LCB = 138.799A ft-FP
 Displacement = 1644 LTons GMT = 43.596 ft TCG = 0.000 ft-CL

DRAFT/GZ DATA

HEEL degrees	RIGHTING ARM ft	DRAFT AFT ft	DRAFT FWD ft	FLOODED WATER LTons
0.0	0.000	6.312	6.870	92
5.0S	3.923	6.223	6.752	97
7.0S	5.180	6.144	6.786	108
10.0S	6.209	6.012	7.155	130
20.0S	5.382	6.161	8.330	155
30.0S	2.683	6.526	9.641	161
40.0S	-0.398	6.935	11.339	163

Note: Drafts are measured at A.P. and F.P along ship's centerline

GZ SUMMARY (Evaluated per IMO (SOLAS'90) Rules for Passenger Ships)
 Available Required

Static Heel Angle	0.0 deg	7.0 deg
Angle at Maximum GZ	14.0S deg	
Maximum GZ	6.468 ft	0.710 ft
Range of Positive GZ	38.7 deg	15.0 deg
Gmt (upright damaged)	42.108 ft	
Righting Area (0.0-22.0)	108.14 ft-deg	2.82 ft-deg

RTRN003B: COLL3
 274' PADDLEWHEELR

Damaged Compartments:

VOID PUMPH1 VOID3 TANKS

	DISPLACEMENT LTons	DRAFT AFT ft	DRAFT FWD ft	TRIM ft	HEEL deg.	UPRIGHT GMT ft
INTACT	1,644	6.790	5.660	1.130A	0.0	43.596
DAMAGED	1,819	6.113	7.632	1.520F	0.0	40.569

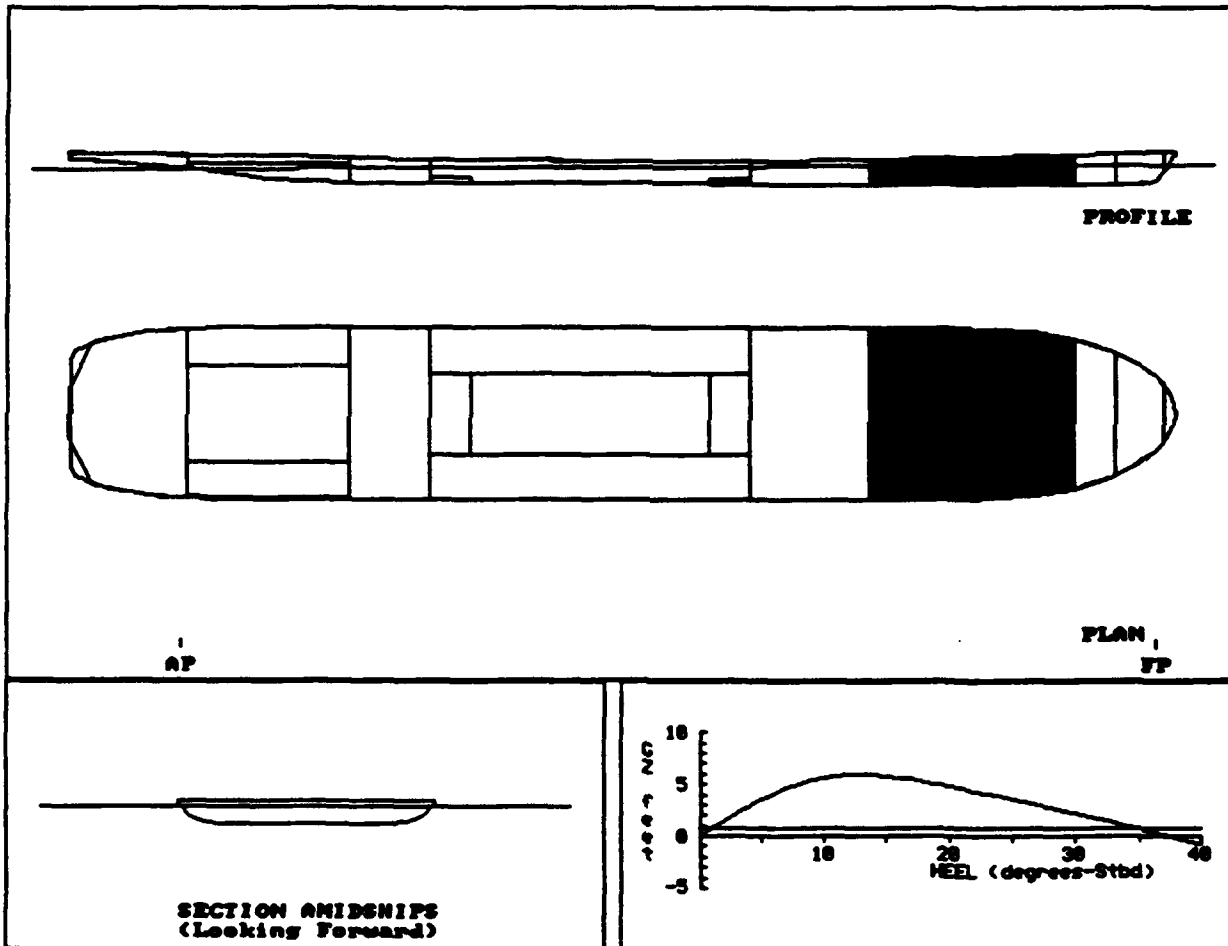

RTRM003B: COLL3
 274' PADDLEWHEELR

COMPARTMENT FLOODING SUMMARY

At 0.0o Heel	PERM.	FLOODED WTR LTons	% FULL (Damaged)	% FULL (Intact)	SP.VOL. ft ³ /LT	OUTFLOW LTons
VOID PUMPRM1	0.95	85	FREE	0.0	----	----
VOID3 TANKS	0.95	90	FREE	0.0	----	----
Totals		175				

INTACT DATA

Draft at AP	= 6.790 ft	KMt	= 63.786 ft	LCG	= 138.723A ft-FP
Draft at FP	= 5.660 ft	VCG	= 20.190 ft	LCB	= 138.799A ft-FP
Displacement	= 1644 LTons	Gmt	= 43.596 ft	TCG	= 0.000 ft-CL

DRAFT/GZ DATA

HEEL degrees	RIGHTING ARM ft	DRAFT AFT ft	DRAFT FWD ft	FLOODED WATER LTons
0.0	0.000	6.113	7.632	175
5.0S	3.620	6.015	7.579	193
7.0S	4.674	5.918	7.730	207
10.0S	5.648	5.853	8.046	216
20.0S	4.863	6.084	9.352	221
30.0S	2.209	6.515	10.942	221
40.0S	-0.810	6.991	13.016	220

Note: Drafts are measured at A.P. and F.P along ship's centerline

-GZ SUMMARY (Evaluated per IMO (SOLAS'90) Rules for Passenger Ships)

	Available	Required
Static Heel Angle	0.0 deg	7.0 deg
Angle at Maximum GZ	14.0S deg	
Maximum GZ	5.927 ft	0.710 ft
Range of Positive GZ	37.4 deg	15.0 deg
Gmt (upright damaged)	40.569 ft	
Righting Area (0.0-22.0)	98.68 ft-deg	2.82 ft-deg

RTRN004B: COLL4
 274' PADDLEWHEEL

Imaged Compartments:
 VOID3 TANKS VOID 4

	DISPLACEMENT LTons	DRAFT AFT ft	DRAFT FWD ft	TRIM ft	HEEL deg.	UPRIGHT GMT ft
INTACT	1,644	6.790	5.660	1.130A	0.0	43.596
DAMAGED	2,037	6.209	8.773	2.564F	0.0	39.720

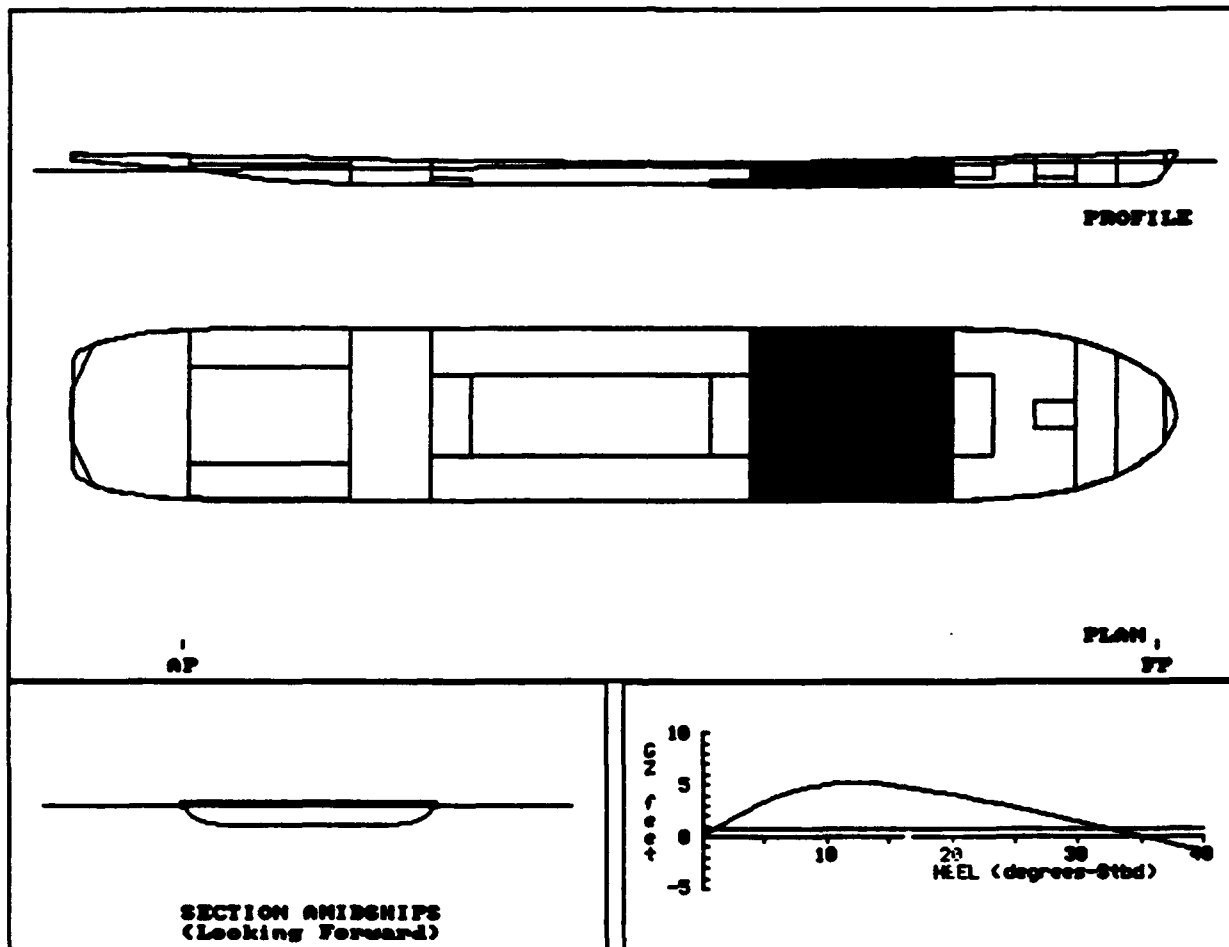

RTRN004B: COLL4
 274'PADDLEWHEELR

COMPARTMENT FLOODING SUMMARY

At 0.0o Heel	PERM.	FLOODED WTR LTons	% FULL (Damaged)	% FULL (Intact)	SP.VOL. ft3/LT	OUTFLOW LTons
VOID3 TANKS	0.95	108	FREE	0.0	----	----
VOID 4	0.95	285	FREE	0.0	----	----
Totals		393				

INTACT DATA

Draft at AP = 6.790 ft KMT = 63.786 ft LCG = 138.723A ft-FP
 Draft at FP = 5.660 ft VCG = 20.190 ft LCB = 138.799A ft-FP
 Displacement = 1644 LTons GMT = 43.596 ft TCG = 0.000 ft-CL

DRAFT/GZ DATA

HEEL degrees	RIGHTING ARM ft	DRAFT AFT ft	DRAFT FWD ft	FLOODED WATER LTons
0.0	0.000	6.209	8.773	393
5.0S	3.352	6.222	8.524	386
7.0S	4.265	6.208	8.584	379
10.0S	5.050	6.247	8.871	371
20.0S	4.089	7.080	10.206	355
30.0S	1.474	8.160	11.951	346
40.0S	-1.449	9.441	14.207	340

Note: Drafts are measured at A.P. and F.P along ship's centerline

GZ SUMMARY (Evaluated per IMO (SOLAS'90) Rules for Passenger Ships)

	Available	Required
Static Heel Angle	0.0 deg	7.0 deg
Angle at Maximum GZ	13.0S deg	
Maximum GZ	5.219 ft	0.730 ft
Range of Positive GZ	35.1 deg	15.0 deg
Gmt (upright damaged)	39.720 ft	
Righting Area (0.0-22.0)	87.06 ft-deg	2.82 ft-deg

RTRN005B: COLLS
 274' PADDLEWHEELR

Imaged Compartments:
 VOID 4 VOID 5

	DISPLACEMENT LTons	DRAFT AFT ft	DRAFT FWD ft	TRIM ft	HEEL deg.	UPRIGHT GMT ft
INTACT	1,644	6.790	5.660	1.130A	0.0	43.596
DAMAGED	2,195	7.357	8.191	0.834F	5.0S	34.368

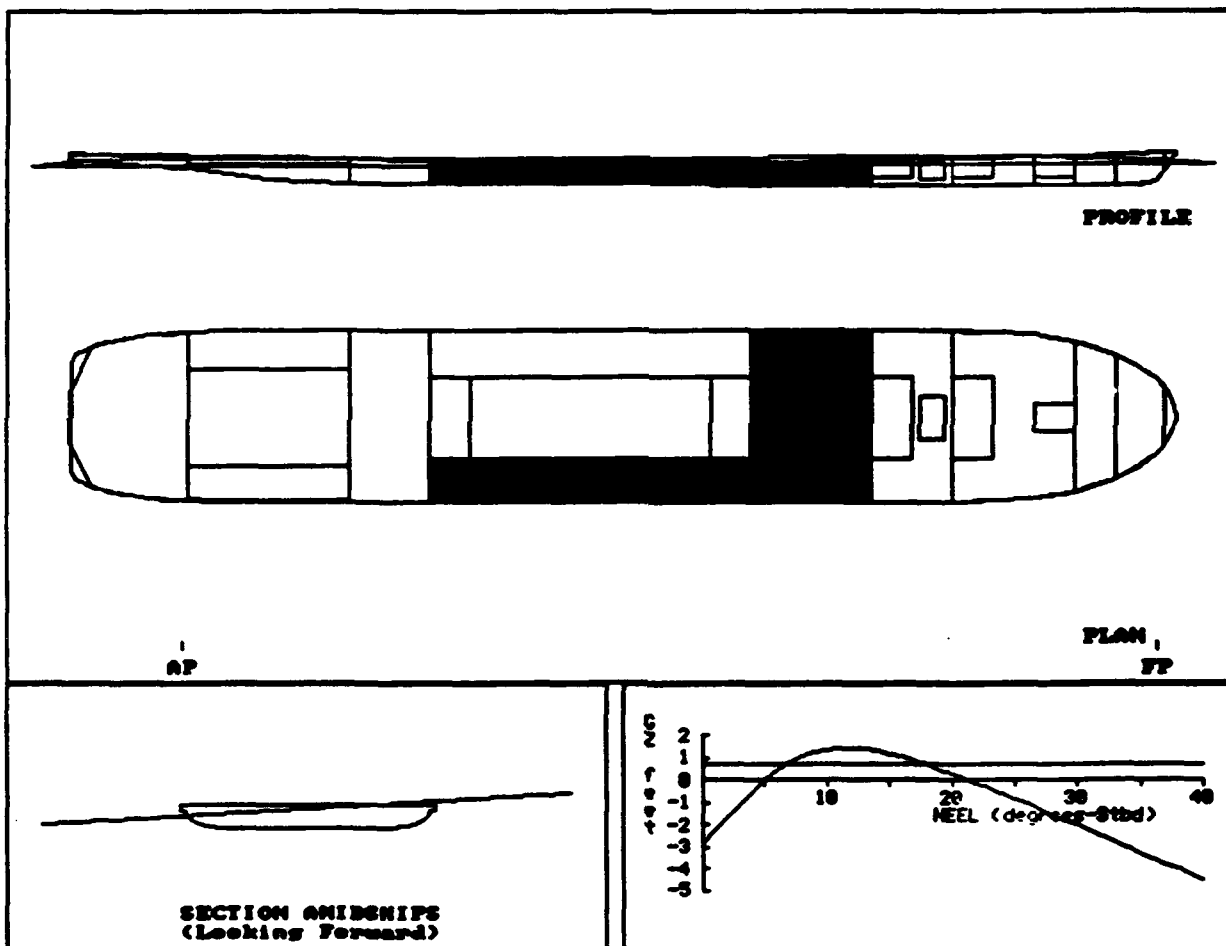

RTRM005B: COLLS
 274' PADDLEWHEELR

COMPARTMENT FLOODING SUMMARY

At 5.0oS Heel	PERM.	FLOODED WTR LTons	% FULL (Damaged)	% FULL (Intact)	SP.VOL. ft ³ /LT	OUTFLOW LTons
VOID 4	0.95	284	FREE	0.0	----	----
VOID 5	0.95	267	FREE	0.0	----	----
Totals		550				

INTACT DATA

Draft at AP = 6.790 ft Kmt = 63.786 ft LCG = 138.723A ft-FP
 Draft at FP = 5.660 ft VCG = 20.190 ft LCB = 138.799A ft-FP
 Displacement = 1644 LTons Gmt = 43.596 ft TCG = 0.000 ft-CL

DRAFT/GZ DATA

HEEL degrees	RIGHTING ARM ft	DRAFT AFT ft	DRAFT FWD ft	FLOODED WATER LTons
0.0	-2.873	7.171	8.204	494
5.0S	0.020	7.358	8.191	550
7.0S	0.841	7.458	8.259	546
10.0S	1.375	7.824	8.421	540
20.0S	0.297	10.256	9.239	529
30.0S	-2.002	13.203	10.436	523
40.0S	-4.504	16.777	12.035	519

Note: Drafts are measured at A.P. and F.P along ship's centerline

GZ SUMMARY (Evaluated per IMO (SOLAS'90) Rules for Passenger Ships)
 Available Required

Static Heel Angle	5.0S deg	7.0 deg
Angle at Maximum GZ	12.0S deg	
Maximum GZ	1.422 ft	0.730 ft
Range of Positive GZ	16.4 deg	15.0 deg
Righting Area (5.0-21.4)	15.28 ft-deg	2.82 ft-deg

RTRN006B: COLL6
 274' PADDLEWHEEL

Imaged Compartments:
 VOID 5 STORE ROOMS

	DISPLACEMENT LTons	DRAFT AFT ft	DRAFT FWD ft	TRIM ft	HEEL deg.	UPRIGHT GMT ft
INTACT	1,644	6.790	5.660	1.130A	0.0	43.596
DAMAGED	2,049	8.437	5.865	2.571A	4.5S	32.133

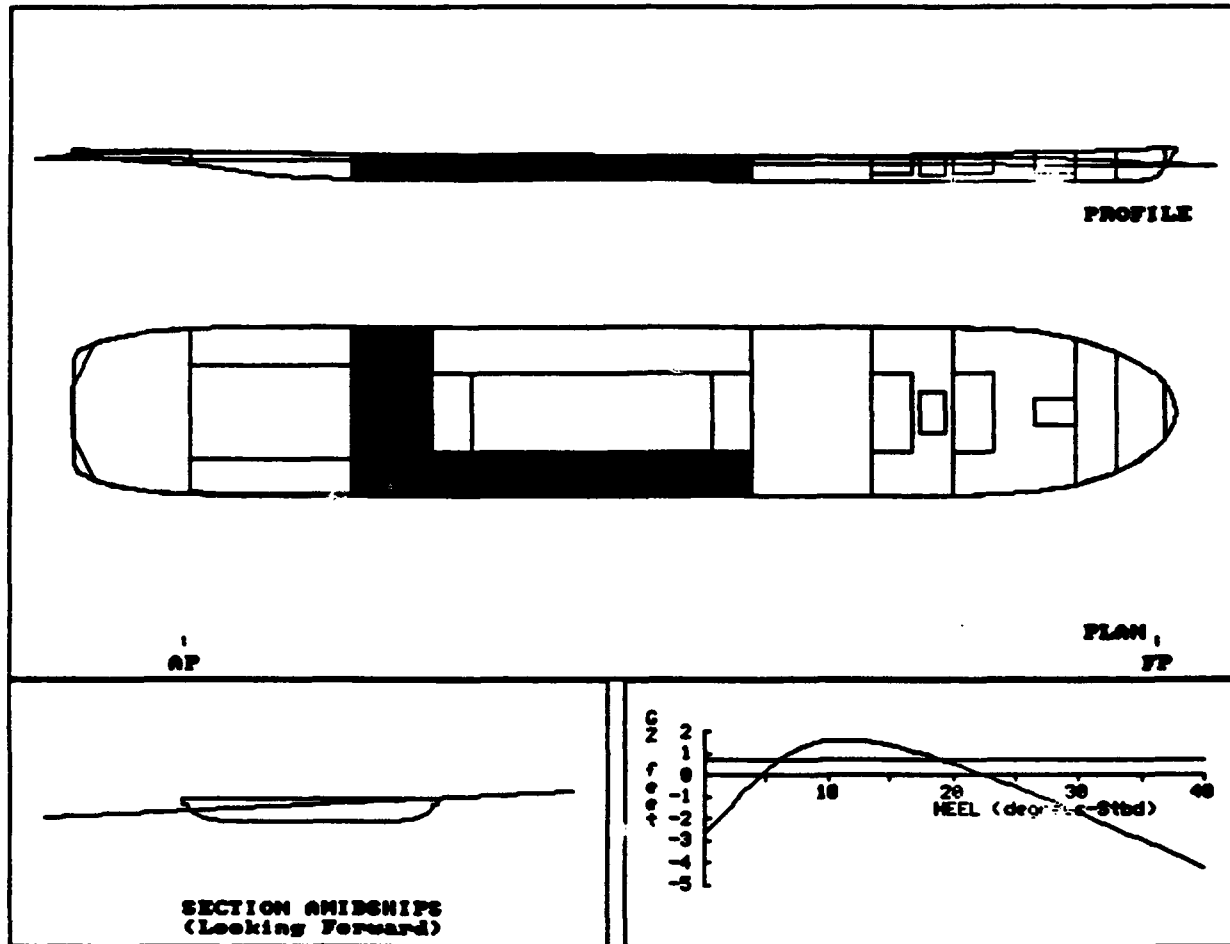

RTRN006B: COLL6
 274' PADDLEWHEEL

COMPARTMENT FLOODING SUMMARY

At 4.5oS Heel	PERM.	FLOODED WTR LTons	% FULL (Damaged)	% FULL (Intact)	SP.VOL. ft ³ /LT	OUTFLOW LTons
VOID 5	0.95	262	FREE	0.0	----	----
STORE ROOMS	0.60	142	FREE	0.0	----	----
Totals		405				

INTACT DATA

Draft at AP = 6.790 ft KMT = 63.786 ft LCG = 138.723A ft-FP
 Draft at FP = 5.660 ft VCG = 20.190 ft LCB = 138.799A ft-FP
 Displacement = 1644 LTons GMT = 43.596 ft TCG = 0.000 ft-CL

DRAFT/GZ DATA

HEEL degrees	RIGHTING ARM ft	DRAFT AFT ft	DRAFT FWD ft	FLOODED WATER LTons
0.0	-2.693	8.293	5.808	339
5.0S	0.243	8.462	5.860	407
7.0S	1.083	8.672	5.764	408
10.0S	1.568	9.370	5.504	408
20.0S	0.571	12.890	4.712	406
30.0S	-1.707	17.186	3.982	406
40.0S	-4.225	22.434	3.164	405

Note: Drafts are measured at A.P. and F.P along ship's centerline

GZ SUMMARY (Evaluated per IMO (SOLAS'90) Rules for Passenger Ships)
 Available R d

Static Heel Angle	4.5S deg	7. deg
Angle at Maximum GZ	12.0S deg	
Maximum GZ	1.603 ft	0.730 ft
Range of Positive GZ	18.2 deg	15.0 deg
Righting Area (4.5-22.0)	19.09 ft-deg	2.00 ft-deg

RTRN007B: COLL7
 274' PADDLEWHEELR

Imaged Compartments:

STORE ROOMS VOID6 UPPER VOID6 LOWER

	DISPLACEMENT LTons	DRAFT AFT ft	DRAFT FWD ft	TRIM ft	HEEL deg.	UPRIGHT GMT ft
INTACT	1,644	6.790	5.660	1.130A	0.0	43.596
DAMAGED	1,782	7.721	5.295	2.427A	0.2S	40.455

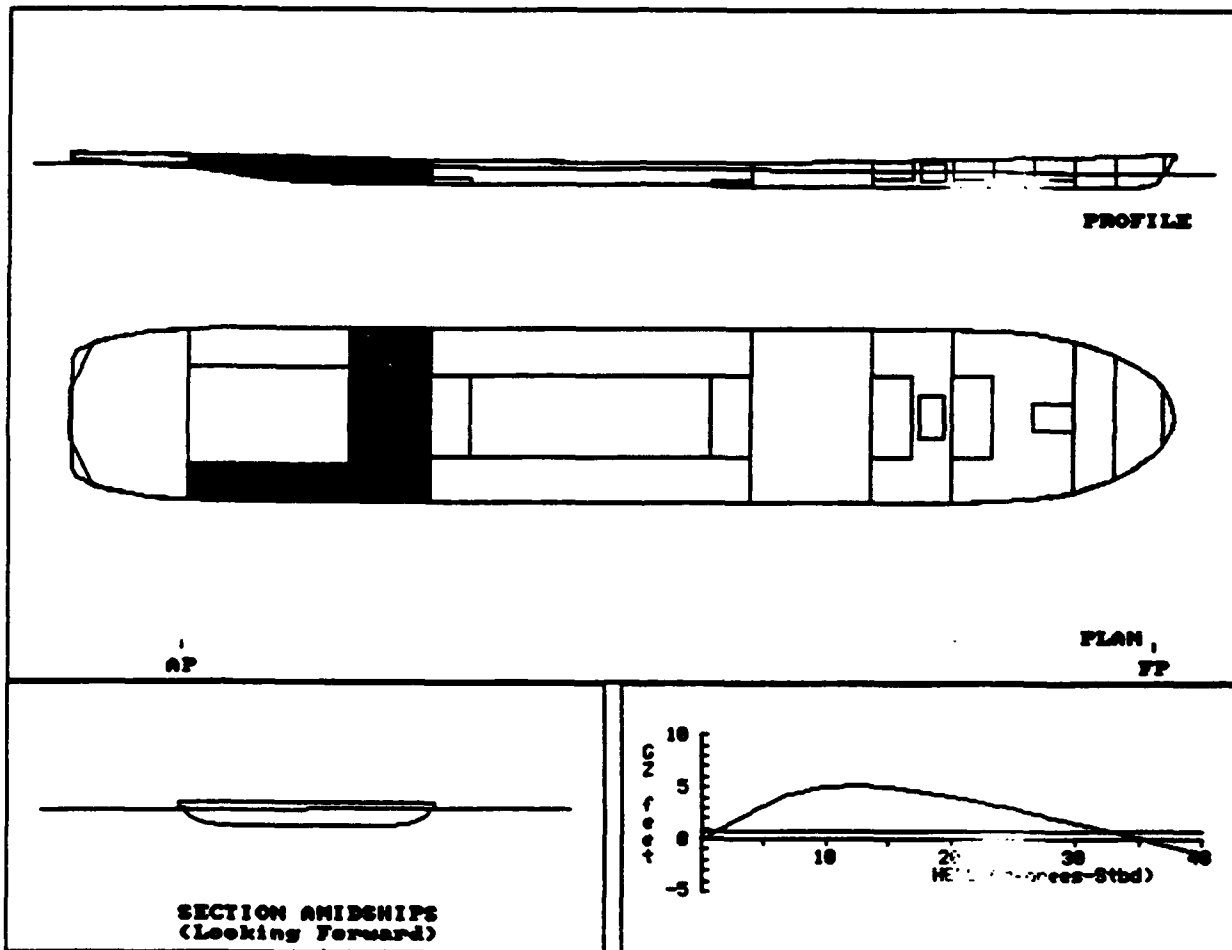

RTRN007B: COLL7
 274' PADDLEWHEELR

COMPARTMENT FLOODING SUMMARY

At 0.2oS Heel	PERM.	FLOODED WTR LTons	% FULL (Damaged)	% FULL (Intact)	SP.VOL. ft ³ /LT	OUTFLOW LTons
STORE ROOMS	0.60	128	FREE	0.0	----	----
VOID6 UPPER	0.95	0	FREE	0.0	----	----
VOID6 LOWER	0.14	9	FREE	0.0	----	----
Totals		137				

INTACT DATA

Draft at AP = 6.790 ft Kmt = 63.786 ft LCG = 138.723A ft-FP
 Draft at FP = 5.660 ft VCG = 20.190 ft LCB = 138.799A ft-FP
 Displacement = 1644 LTons GMT = 43.596 ft TCG = 0.000 ft-CL

DRAFT/GZ DATA

HEEL degrees	RIGHTING ARM ft	DRAFT AFT ft	DRAFT FWD ft	FLOODED WATER LTons
0.0	-0.136	7.716	5.304	137
5.0S	3.209	7.866	5.057	160
7.0S	4.215	7.991	4.919	175
10.0S	4.988	8.455	4.614	176
20.0S	4.122	11.137	3.431	173
30.0S	1.565	14.322	2.209	173
40.0S	-1.356	18.223	0.765	172

Note: Drafts are measured at A.P. and F.P along ship's centerline

GZ SUMMARY (Evaluated per IMO (SOLAS'90) Rules for Passenger Ships)
 Available Required

Static Heel Angle	0.2S deg	7.0 deg
Angle at Maximum GZ	13.0S deg	
Maximum GZ	5.144 ft	0.730 ft
Range of Positive GZ	35.2 deg	15.0 deg
Righting Area (0.2-22.0)	85.69 ft-deg	2.0 ft-deg

RTRN008B: COLLS
 274' PADDLEWHEELR

Damaged Compartments:

VOID6 UPPER VOID6 LOWER WHEEL BEAM

	DISPLACEMENT Tons	DRAFT AFT ft	DRAFT FWD ft	TRIM ft	HEEL deg.	UPRIGHT GMT ft
INTACT	7,644	6.790	5.660	1.130A	0.0	43.596
DAMAGED	1,653	6.854	5.626	1.228A	0.2S	42.541

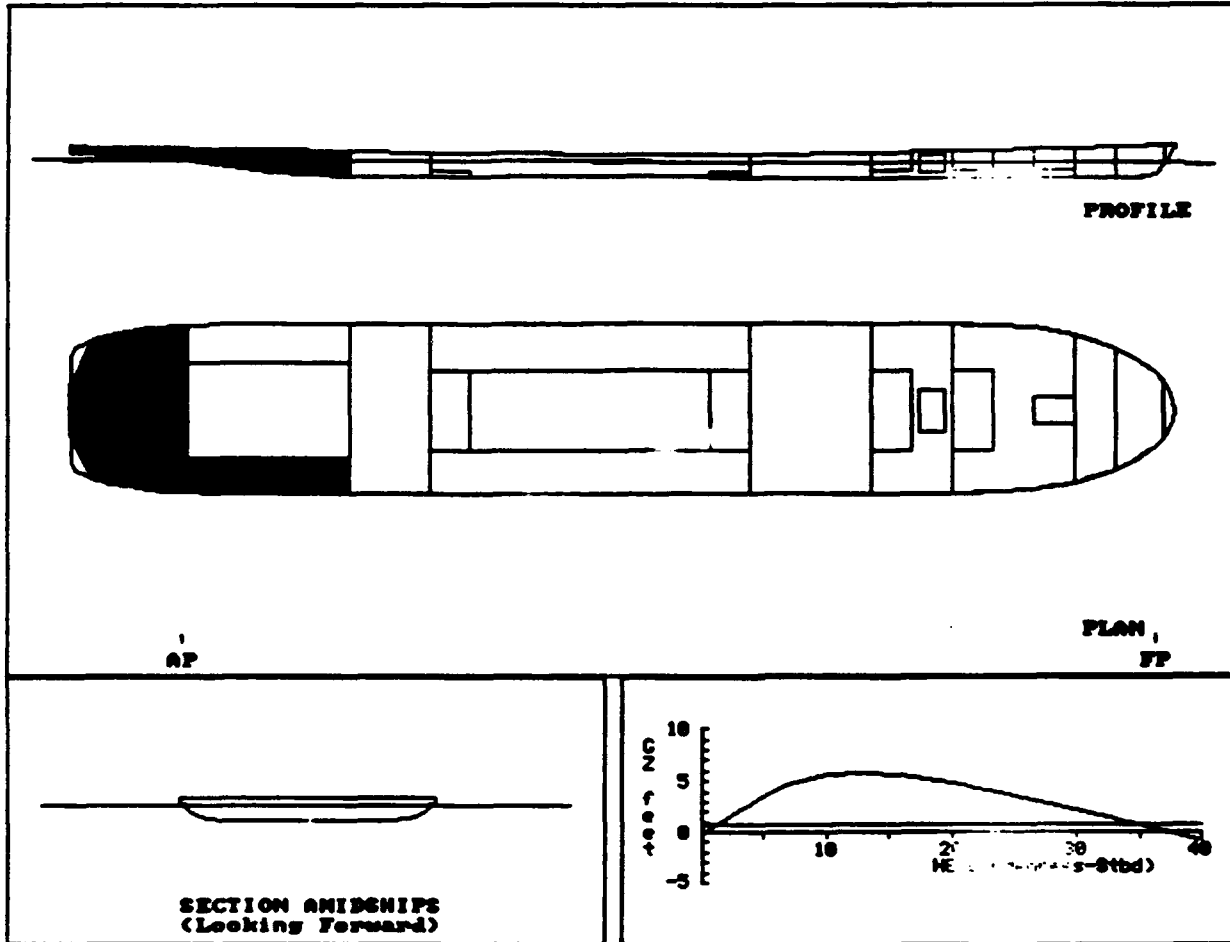

RTRN008B: COLLS
 274' PADDLEWHEELR

COMPARTMENT FLOODING SUMMARY

At 0.2oS Heel	PERM.	FLOODED WTR LTons	% FULL (Damaged)	% FULL (Intact)	SP.VOL. ft ³ /LT	OUTFLOW LTons
VOID6 UPPER	0.95	0	FREE	0.0	----	----
VOID6 LOWER	0.14	8	FREE	0.0	----	----
WHEEL BEAM	0.95	0	FREE	0.0	----	----
Totals		8				

INTACT DATA

Draft at AP = 6.790 ft	KMT = 63.786 ft	LCG = 138.723A ft-FP
Draft at FP = 5.660 ft	VCG = 20.190 ft	LCB = 138.799A ft-FP
Displacement = 1644 LTons	GMT = 43.596 ft	TCG = 0.000 ft-CL

DRAFT/GZ DATA

HEEL degrees	RIGHTING ARM ft	DRAFT AFT ft	DRAFT FWD ft	FLOODED WATER LTons
0.0	-0.113	6.849	5.634	8
5.0S	3.468	7.019	5.343	32
7.0S	4.603	7.181	5.122	55
10.0S	5.523	7.604	4.779	73
20.0S	4.826	9.620	3.702	76
30.0S	2.218	11.983	2.606	75
40.0S	-0.790	14.870	1.321	77

Note: Drafts are measured at A.P. and F.P along ship's centerline

GZ SUMMARY (Evaluated per IMO (SOLAS'90) Rules for Passenger Ships)
 Available

Static Heel Angle	0.2S deg	7. deg
Angle at Maximum GZ	14.0S deg	
Maximum GZ	5.768 ft	0.730 ft
Range of Positive GZ	37.3 deg	15. deg
Righting Area (0.2-22.0)	96.30 ft-deg	2. ft-deg

RTRM009B: COLL9
 274' PADDLEWHEEL

Damaged Compartments:

VOID6 UPPER VOID6 LOWER WHEEL BEAM PUMP RM AFT

	DISPLACEMENT LTons	DRAFT AFT ft	DRAFT FWD ft	TRIM ft	HEEL deg.	UPRIGHT GMT ft
INTACT	1,644	6.790	5.660	1.130A	0.0	43.596
DAMAGED	1,871	8.714	4.484	4.230A	0.3S	35.074

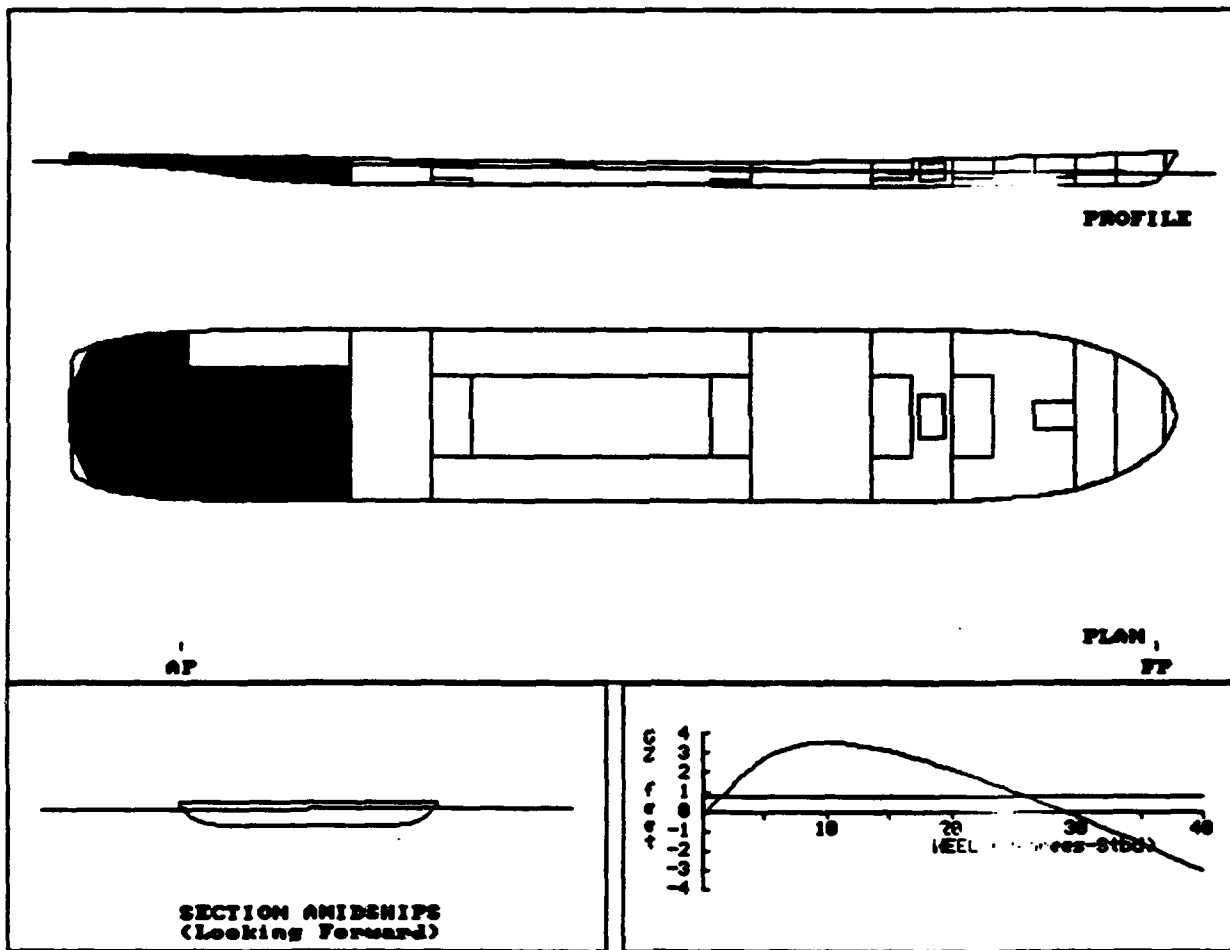

RTRN009B: COLL9
 274' PADDLEWHEELER

COMPARTMENT FLOODING SUMMARY

At 0.3oS Heel	PERM.	FLOODED WTR LTons	% FULL (Damaged)	% FULL (Intact)	SP.VOL. ft ³ /LT	OUTFLOW LTons
VOID6 UPPER	0.95	7	FREE	0.0	----	----
VOID6 LOWER	0.14	10	FREE	0.0	----	----
WHEEL BEAM	0.95	13	FREE	0.0	----	----
PUMP RM AFT	0.85	197	FREE	0.0	----	----
Totals		227				

INTACT DATA

Draft at AP = 6.790 ft	KMT = 63.786 ft	LCG = 138.723A ft-FP
Draft at FP = 5.660 ft	VCG = 20.190 ft	LCB = 138.799A ft-FP
Displacement = 1644 LTons	GMT = 43.596 ft	TCG = 0.000 ft-CL

DRAFT/GZ DATA

HEEL degrees	RIGHTING ARM ft	DRAFT AFT ft	DRAFT FWD ft	FLOODED WATER LTons
0.0	-0.216	8.686	4.511	223
5.0S	2.729	9.227	4.038	285
7.0S	3.281	9.788	3.666	301
10.0S	3.526	10.969	3.001	320
20.0S	2.170	16.204	0.520	352
30.0S	-0.279	22.314	-2.173	363
40.0S	-3.061	29.999	-5.670	379

Note: Drafts are measured at A.P. and F.P along ship's centerline

GZ SUMMARY (Evaluated per IMO (SOLAS'90) Rules for Passenger Ships)

	Available	Required
Static Heel Angle	0.3S deg	7.0 deg
Angle at Maximum GZ	11.0S deg	
Maximum GZ	3.526 ft	0.730 ft
Range of Positive GZ	28.6 deg	15.0 deg
Righting Area (0.3-22.0)	57.40 ft-deg	2.8 ft-deg

**APPENDIX B
HYDROSTATICS AND
DAMAGE STABILITY
OUTPUT**

91' CREW BOAT A

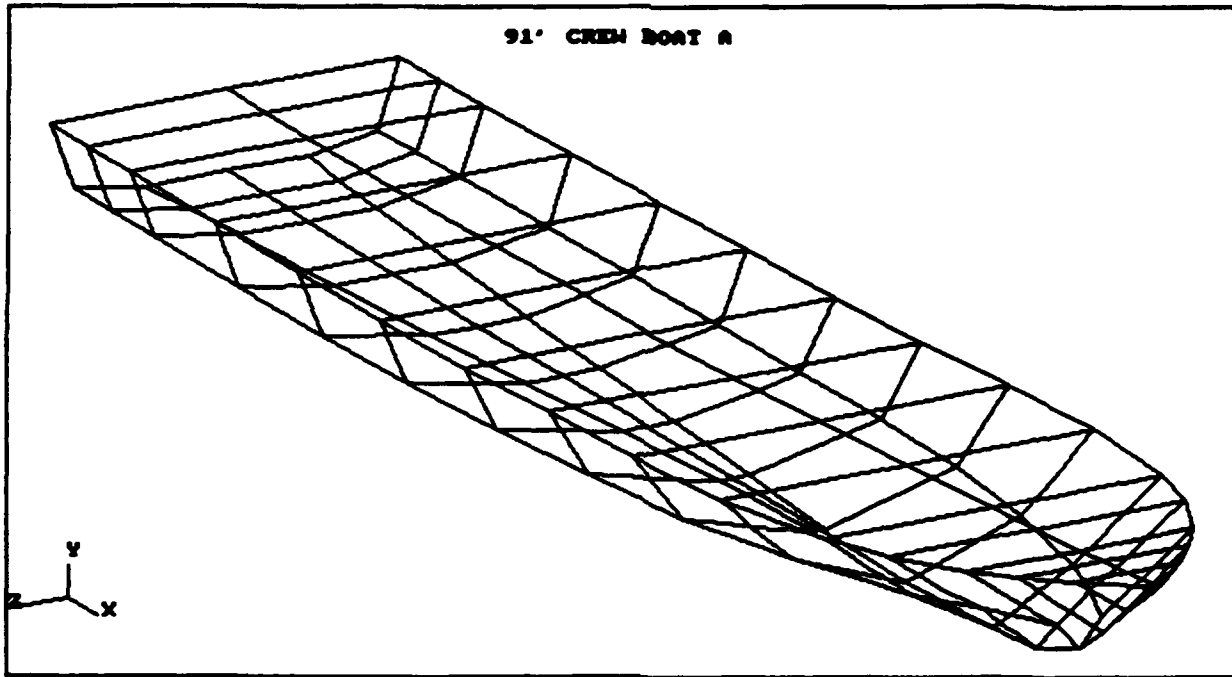

DAMAGE STABILITY SUMMARY
91' CREW BOAT A

CASE No.	FILE NAME	DAMAGED COMP. LISTING	---Intact Condition---			-----Equilibrium Condition After Damage-----					
			MIN.DRAFT (ft)	VCG (ft)	GMt (ft)	HEEL (deg)	MAX.GZ (ft)	RANGE (deg)	AREA (ft-deg)	DAM.GMt (ft)	SURVIVAL
1	DPRTO01A	1	3.875	9.810	4.250	0.0	1.250	50.00	15.71	4.250	Yes
2	DPRTO02A	2	3.875	9.810	4.250	0.0	1.326	48.97	16.04	4.022	Yes
3	DPRTO03A	3	3.875	9.810	4.250	0.0	0.835	42.03	9.36	1.946	Yes
4	DPRTO04A	4	3.875	9.810	4.250	0.0	1.232	50.00	15.74	4.228	Yes
5	DPRTO05A	5	3.875	9.810	4.250	2.3P	0.882	45.14	10.51	----	Yes
6	DPRTO06A	4,5	3.875	9.810	4.250	2.2P	0.893	44.32	10.86	----	Yes
7	DPRTO07A	7	3.875	9.810	4.250	0.0	0.721	41.26	9.58	2.449	Yes
8	DPRTO08A	8	3.875	9.810	4.250	0.0	0.903	43.28	11.51	2.918	Yes

DAMAGE STABILITY SUMMARY
91' CREW BOAT A

No.	FILE NAME	DAMAGED COMP. LISTING	---Intact Condition---			-----Equilibrium Condition After Damage-----					
			MN.DRAFT (ft)	VCG (ft)	GMt (ft)	HEEL (deg)	MAX.GZ (ft)	RANGE (deg)	AREA (ft-deg)	DAM.GMt (ft)	SURVIVAL
1	RTRN001B	1	3.575	10.240	4.960	0.0	1.155	50.00	16.32	4.956	Yes
2	RTRN002B	2	3.575	10.240	4.960	0.0	1.237	48.24	16.80	4.715	Yes
3	RTRN003B	3	3.575	10.240	4.960	0.0	0.800	42.48	9.43	2.145	Yes
4	RTRN004B	4	3.575	10.240	4.960	0.0	1.159	50.00	16.42	4.916	Yes
5	RTRN005B	5	3.575	10.240	4.960	1.6S	1.036	48.43	12.66	----	Yes
6	RTRN006B	4,5	3.575	10.240	4.960	1.6S	1.040	48.40	12.94	----	Yes
7	RTRN007B	7	3.575	10.240	4.960	0.0	0.788	42.96	10.29	2.703	Yes
8	RTRN008B	8	3.575	10.240	4.960	0.0	0.942	44.69	12.22	3.278	Yes

HYDROSTATIC TABLES
 91' CREW BOAT A

MOLDED DRAFT (ft)	0.500	1.000	1.500	2.000	2.500	3.000	3.500	4.000	4.500
DISP.MLD. (LTons-SW)	1	5	14	27	44	63	84	105	127
DISP.TOTAL (LTons-SW)	1	5	14	27	44	64	84	105	127
DISP.TOTAL (LTons-FW)	1	4	14	27	43	62	82	103	124
LCB (ft-FP)	29.975A	41.816A	49.985A	52.451A	53.414A	53.499A	53.243A	52.910A	52.579A
LCB (forebody) (ft-FP)	28.850A	29.681A	29.674A	29.556A	29.417A	29.267A	29.081A	28.827A	28.563A
LCB (aftbody) (ft-FP)	47.501A	58.345A	65.234A	66.960A	67.599A	67.733A	67.787A	67.818A	67.837A
TCB (ft-CL)	0.000	0.000	0.000	0.000	0.000	0.000	0.000	0.000	0.000
KB (ft)	0.363	0.743	1.097	1.421	1.740	2.046	2.339	2.623	2.902
BMT (ft)	3.680	11.642	15.558	18.166	19.448	16.223	13.447	11.461	10.019
KMT (ft)	4.043	12.384	16.654	19.587	21.188	18.269	15.785	14.084	12.921
BMI (ft)	564.705	986.263	813.544	553.082	414.071	320.856	263.405	224.094	194.145
KMI (ft)	565.068	987.006	814.641	554.503	415.810	322.901	265.744	226.716	197.047
(LTons)	0.3	1.1	1.9	2.5	3.1	3.3	3.5	3.6	3.7
(ft-LTons)	0	4	10	14	17	19	20	22	23
(LTons)	-0.0	0.0	0.2	0.3	0.3	0.3	0.2	0.2	0.2
LCF (ft-FP)	32.364A	48.539A	54.966A	55.056A	54.555A	53.030A	51.982A	51.236A	50.761A
W.P. AREA (ft2)	109	450	806	1,062	1,284	1,392	1,457	1,507	1,546
WETTED SUR. (ft2)	115	468	844	1,124	1,379	1,542	1,672	1,791	1,901
MAX. BEAM (ft)	3.972	8.328	12.280	16.231	19.009	19.257	19.505	19.753	20.024
LENGTH W.L. (ft)	44.413	76.452	87.271	88.304	89.337	90.369	90.902	91.363	91.825
Cb	0.0209	0.0766	0.1553	0.2281	0.2955	0.3534	0.4004	0.4389	0.4711
Cb (forebody)	0.0394	0.0883	0.1332	0.1770	0.2196	0.2615	0.3009	0.3356	0.3661
Cb (aftbody)	0.0025	0.0648	0.1774	0.2792	0.3715	0.4453	0.4999	0.5421	0.5762
Cm	0.0647	0.1423	0.2261	0.3040	0.3893	0.4630	0.5173	0.5593	0.5932
Cp	0.3239	0.5379	0.6870	0.7504	0.7593	0.7633	0.7740	0.7847	0.7943
Cwp	0.0520	0.2148	0.3852	0.5073	0.6135	0.6650	0.6963	0.7200	0.7385
Cit	0.0009	0.0202	0.0822	0.1880	0.3260	0.3902	0.4274	0.4564	0.4819

Assumes: Sea Water at 35.0063 ft3/LT
 Fresh Water at 35.8814 ft3/LT
 Ship floating at even keel (no heel or trim)

**DPRT001A:
 91' CREW BOAT A**

Damaged Compartments:

100

	DISPLACEMENT LTons	DRAFT AFT ft	DRAFT FWD ft	TRIM ft	HEEL deg.	UPRIGHT GMT ft
INTACT	103.2	4.410	3.340	1.070A	0.00	4.250
DAMAGED	104.2	4.354	3.465	0.889A	0.00	4.250

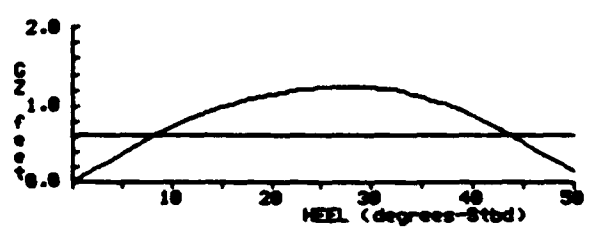
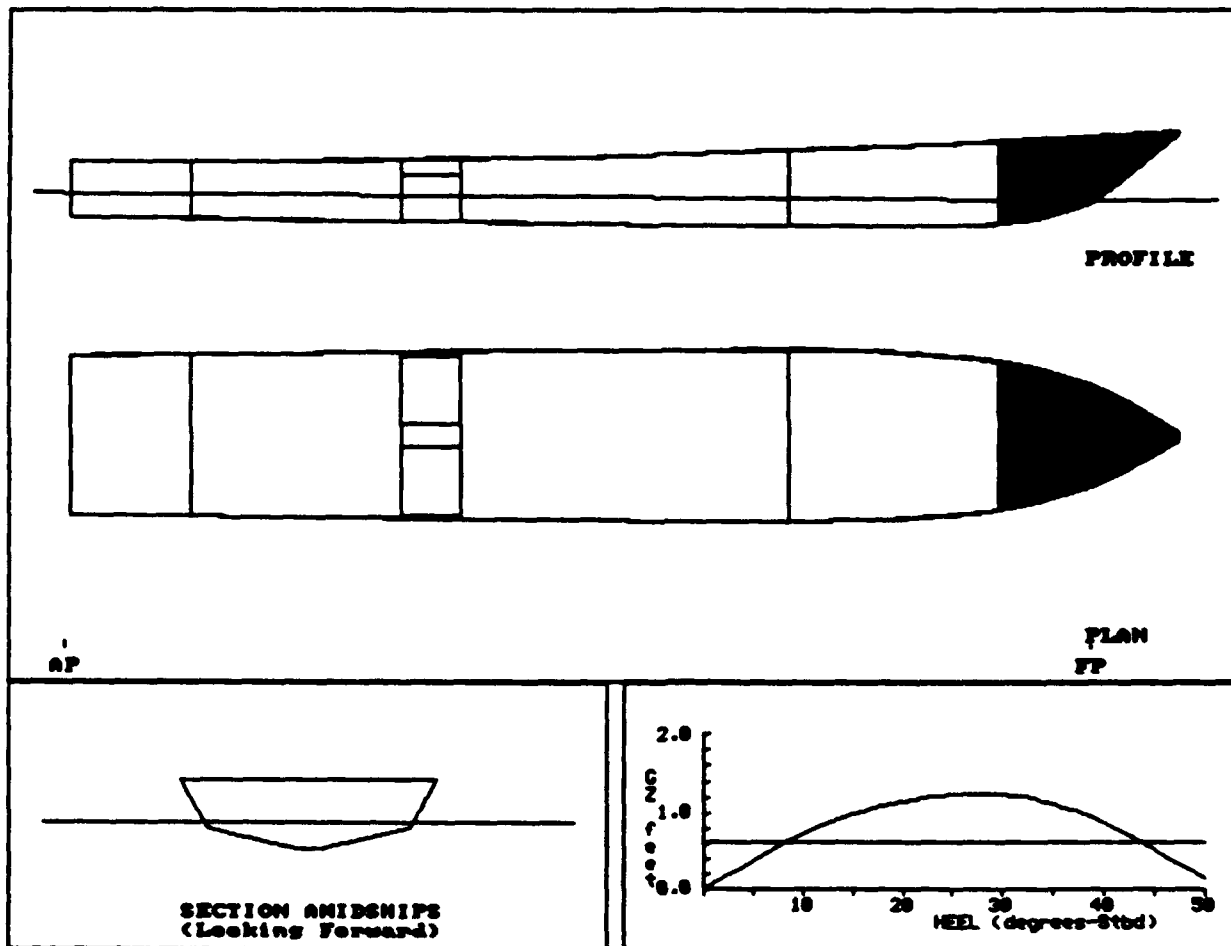

DPR001A:
 91' CREW BOAT A

COMPARTMENT FLOODING SUMMARY

At 0.0o Heel	PERM.	FLOODED WTR LTons	% FULL (Damaged)	% FULL (Intact)	SP.VOL. ft ³ /LT	OUTFLOW LTons
100	0.95	0.9	FREE	0.0	----	----
Totals		0.9				

INTACT DATA

Draft at AP = 4.410 ft KMT = 14.060 ft LCG = 55.475A ft-FP
 Draft at FP = 3.340 ft VCG = 9.810 ft LCB = 55.560A ft-FP
 Displacement = 103.2 LTons GMT = 4.250 ft TCG = 0.000 ft-CL

DRAFT/GZ DATA

HEEL degrees	RIGHTING ARM ft	DRAFT AFT ft	DRAFT FWD ft	FLOODED WATER LTons
0.00	0.000	4.354	3.465	0.9
5.00S	0.372	4.362	3.420	0.9
7.00S	0.518	4.361	3.387	0.9
10.00S	0.726	4.344	3.325	0.9
20.00S	1.146	4.137	2.877	0.6
30.00S	1.236	3.578	2.136	0.3
40.00S	0.873	3.039	0.821	0.0
50.00S	0.145	2.367	-1.024	0.0

Note: Drafts are measured at A.P. and F.P along ship's centerline

GZ SUMMARY (Evaluated per IMO (SOLAS'90) Rules for Passenger Ships)

	Available	Required
Static Heel Angle	0.00 deg	7.00 deg
Angle at Maximum GZ	28.00S deg	
Maximum GZ	1.250 ft	0.630 ft
Range of Positive GZ	50.00 deg	15.00 deg
Gmt (upright damaged)	4.250 ft	
Righting Area (0.00-7.00)	15.711 ft-deg	2.820 ft-deg

DPR002A:
 91' CREW BOAT A

Imaged Compartments:
 200

	DISPLACEMENT LTons	DRAFT AFT ft	DRAFT FWD ft	TRIM ft	HEEL deg.	UPRIGHT GMT ft
INTACT	103.2	4.410	3.340	1.070A	0.00	4.250
DAMAGED	122.7	3.772	5.169	1.397F	0.00	4.022

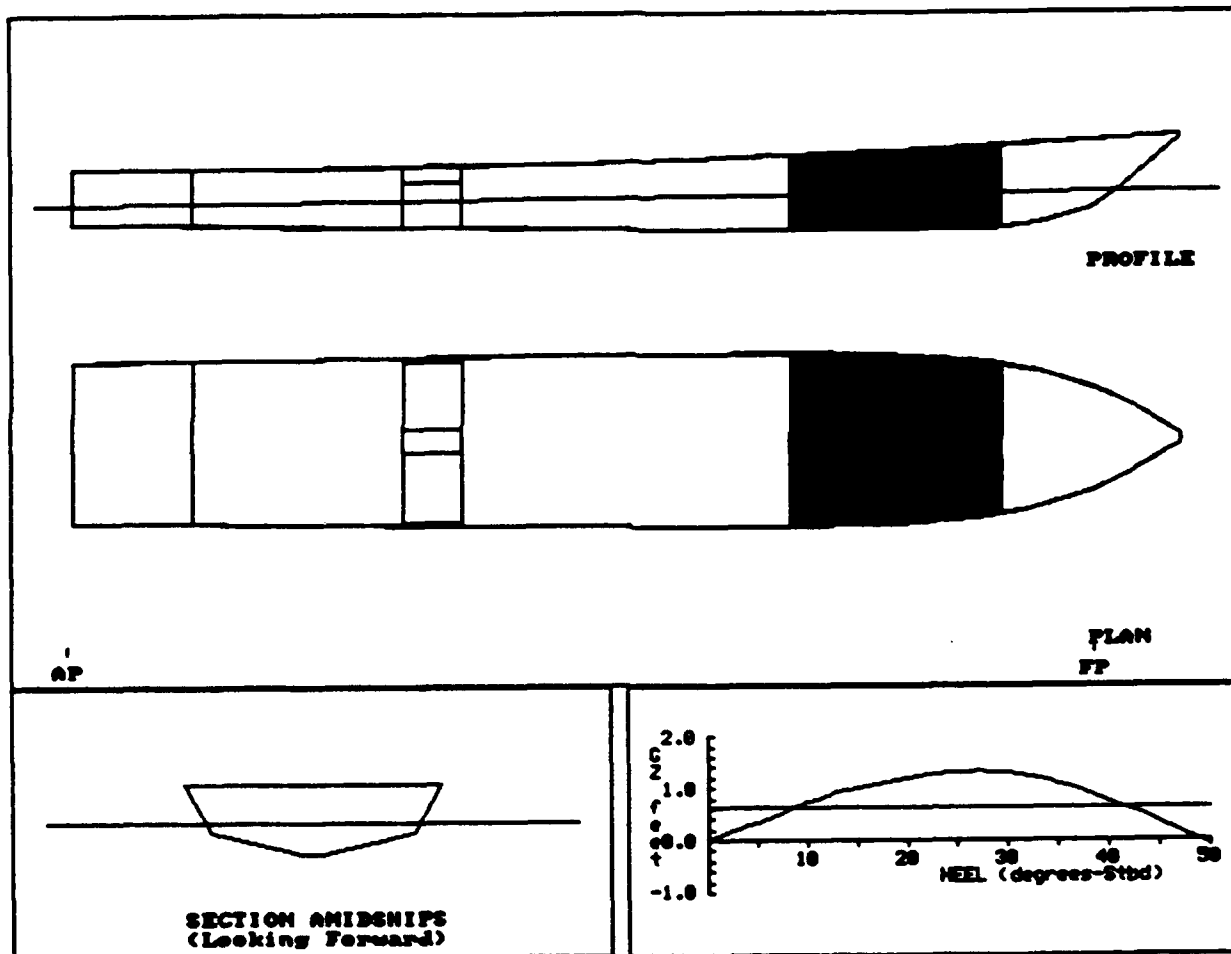

DPRT002A:
 91' CREW BOAT A

COMPARTMENT FLOODING SUMMARY

At 0.0o Heel	PERM.	FLOODED WTR LTons	% FULL (Damaged)	% FULL (Intact)	SP.VOL. ft3/LT	OUTFLOW LTons
200	0.95	19.5	FREE	0.0	----	----
Totals		19.5				

INTACT DATA

Draft at AP = 4.410 ft KMT = 14.060 ft LCG = 55.475A ft-FP
 Draft at FP = 3.340 ft VCG = 9.810 ft LCB = 55.560A ft-FP
 Displacement = 103.2 LTons GMT = 4.250 ft TCG = 0.000 ft-CL

DRAFT/GZ DATA

HEEL degrees	RIGHTING ARM ft	DRAFT AFT ft	DRAFT FWD ft	FLOODED WATER LTons
0.00	0.000	3.772	5.169	19.5
5.00S	0.355	3.768	5.147	19.5
7.00S	0.501	3.761	5.131	19.5
10.00S	0.730	3.749	5.089	19.6
20.00S	1.200	3.463	4.826	19.8
30.00S	1.296	2.806	4.303	20.4
40.00S	0.756	1.998	3.667	21.8
50.00S	-0.089	1.015	2.687	22.2

Note: Drafts are measured at A.P. and F.P along ship's centerline

GZ SUMMARY (Evaluated per IMO (SOLAS'90) Rules for Passenger Ships)

	Available	Required
Static Heel Angle	0.00 deg	7.00 deg
Angle at Maximum GZ	28.00S deg	
Maximum GZ	1.326 ft	0.630 ft
Range of Positive GZ	48.97 deg	15.00 deg
Gmt (upright damaged)	4.022 ft	
Righting Area (0.00-%.00)	16.038 ft-deg	2.820 ft-deg

DPRT003A:
 91' CREW BOAT A

Imaged Compartments:
 300

	DISPLACEMENT LTons	DRAFT AFT ft	DRAFT FWD ft	TRIM ft	HEEL deg.	UPRIGHT GMT ft
INTACT	103.2	4.410	3.340	1.070A	0.00	4.250
DAMAGED	160.3	4.834	5.706	0.872F	0.00	1.946

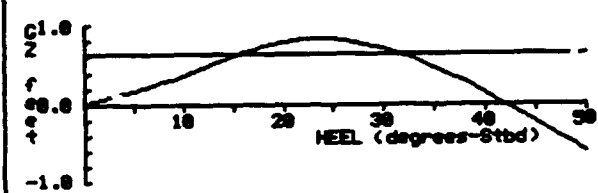
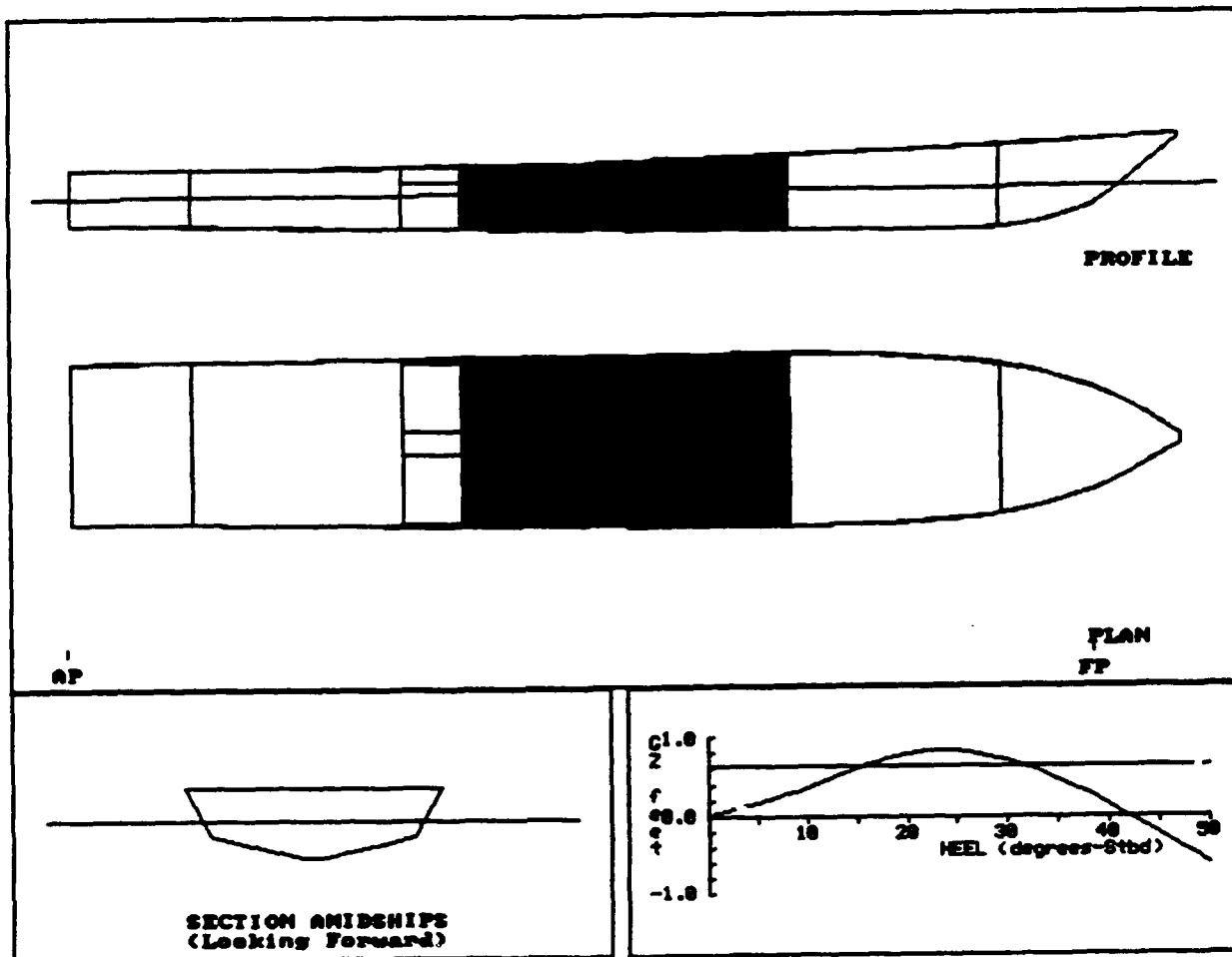

**DPRT003A:
 91' CREW BOAT A**

COMPARTMENT FLOODING SUMMARY

At 0.0o Heel	PERM.	FLOODED WTR LTons	% FULL (Damaged)	% FULL (Intact)	SP.VOL. ft3/LT	OUTFLOW LTons
300	0.95	57.1	FREE	0.0	----	----
Totals		57.1				

INTACT DATA

Draft at AP = 4.410 ft	KMt = 14.060 ft	LCG = 55.475A ft-FP
Draft at FP = 3.340 ft	VCG = 9.810 ft	LCB = 55.560A ft-FP
Displacement = 103.2 LTons	GMT = 4.250 ft	TCG = 0.000 ft-CL

DRAFT/GZ DATA

HEEL degrees	RIGHTING ARM ft	DRAFT AFT ft	DRAFT FWD ft	FLOODED WATER LTons
0.00	0.000	4.834	5.706	57.1
5.00S	0.173	4.825	5.689	57.1
7.00S	0.246	4.819	5.668	57.1
10.00S	0.365	4.809	5.620	57.0
20.00S	0.797	4.678	5.335	57.1
30.00S	0.705	4.540	4.725	57.0
40.00S	0.147	4.541	3.881	56.0
50.00S	-0.617	4.624	2.769	55.1

Note: Drafts are measured at A.P. and F.P along ship's centerline

GZ SUMMARY (Evaluated per IMO (SOLAS'90) Rules for Passenger Ships)

	Available	Required
Static Heel Angle	0.00 deg	7.00 deg
Angle at Maximum GZ	24.00S deg	
Maximum GZ	0.835 ft	0.630 ft
Range of Positive GZ	42.03 deg	15.00 deg
Gmt (upright damaged)	1.946 ft	
Righting Area (0.00-%.00)	9.357 ft-deg	2.820 ft-deg

DPRT004A:
 91' CREW BOAT A

Imaged Compartments:
 400

	DISPLACEMENT LTons	DRAFT AFT ft	DRAFT FWD ft	TRIM ft	HEEL deg.	UPRIGHT GMT ft
INTACT	103.2	4.410	3.340	1.070A	0.00	4.250
DAMAGED	105.0	4.473	3.355	1.118A	0.00	4.228

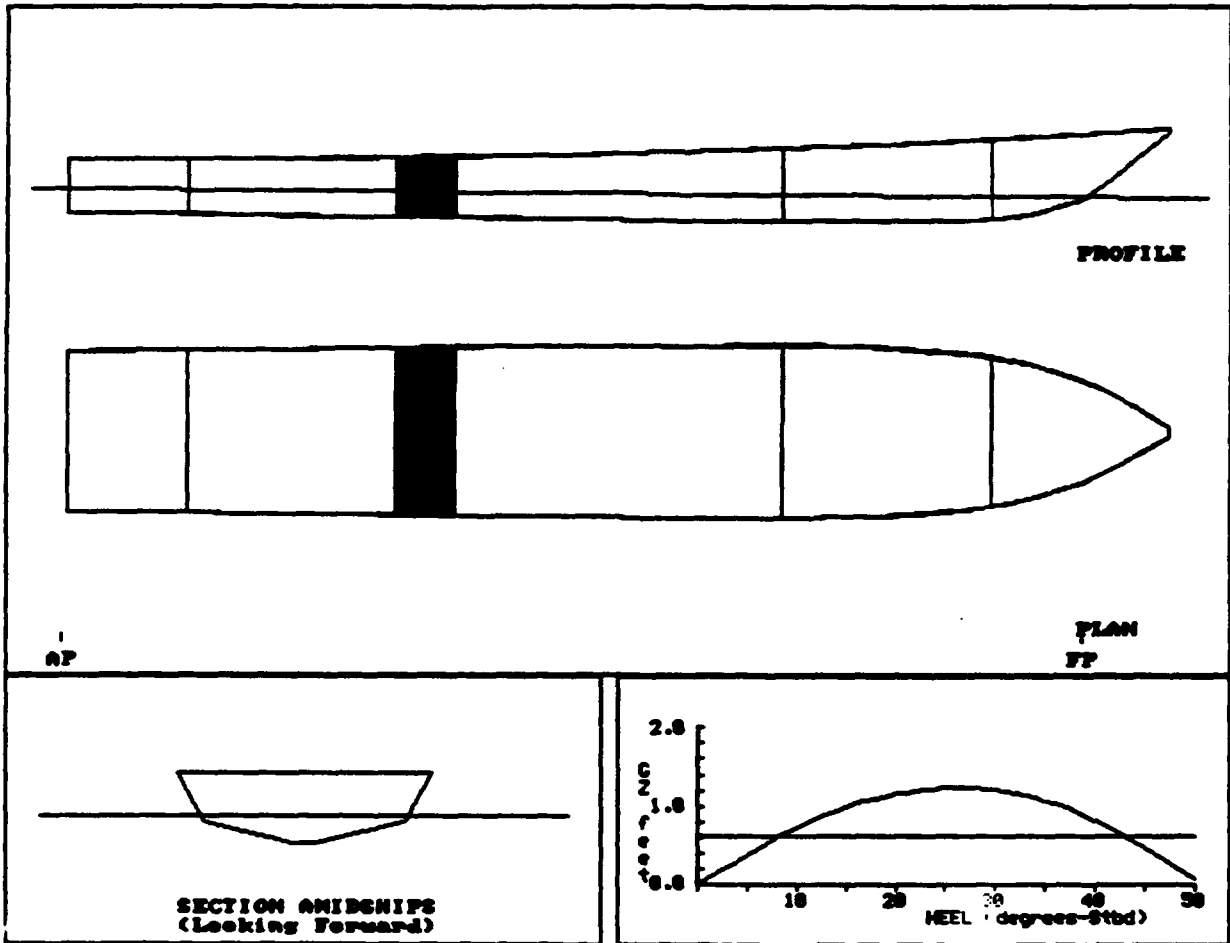

**DPRT004A:
 91' CREW BOAT A**

COMPARTMENT FLOODING SUMMARY

At 0.0o Heel	PERM.	FLOODED WTR LTons	% FULL (Damaged)	% FULL (Intact)	SP.VOL. ft3/LT	OUTFLOW LTons
400	0.95	1.8	FREE	0.0	----	----
Totals		1.8				

INTACT DATA

Draft at AP = 4.410 ft Kmt = 14.060 ft LCG = 55.475A ft-FP
 Draft at FP = 3.340 ft VCG = 9.810 ft LCB = 55.560A ft-FP
 Displacement = 103.2 LTons GMT = 4.250 ft TCG = 0.000 ft-CL

DRAFT/GZ DATA

HEEL degrees	RIGHTING ARM ft	DRAFT AFT ft	DRAFT FWD ft	FLOODED WATER LTons
0.00	0.000	4.473	3.355	1.8
5.00S	0.370	4.481	3.311	1.8
7.00S	0.515	4.478	3.279	1.8
10.00S	0.724	4.458	3.222	1.8
20.00S	1.153	4.252	2.800	1.8
30.00S	1.205	3.725	2.090	2.2
40.00S	0.819	3.228	0.816	2.3
50.00S	0.070	2.621	-1.022	2.3

Note: Drafts are measured at A.P. and F.P along ship's centerline

GZ SUMMARY (Evaluated per IMO (SOLAS'90) Rules for Passenger Ships)

	Available	Required
Static Heel Angle	0.00 deg	7.00 deg
Angle at Maximum GZ	27.00S deg	
Maximum GZ	1.232 ft	0.630 ft
Range of Positive GZ	50.00 deg	15.00 deg
Gmt (upright damaged)	4.228 ft	
Righting Area (0.00-7.00)	15.739 ft-deg	2.820 ft-deg

**DPRT005A:
 91' CREW BOAT A**

**Damaged Compartments:
 FO TANK STBD**

	DISPLACEMENT LTons	DRAFT AFT ft	DRAFT FWD ft	TRIM ft	HEEL deg.	UPRIGHT CNT ft
INTACT	103.2	4.410	3.340	1.070A	0.00	4.250
DAMAGED	100.4	4.309	3.306	1.003A	2.31P	3.911

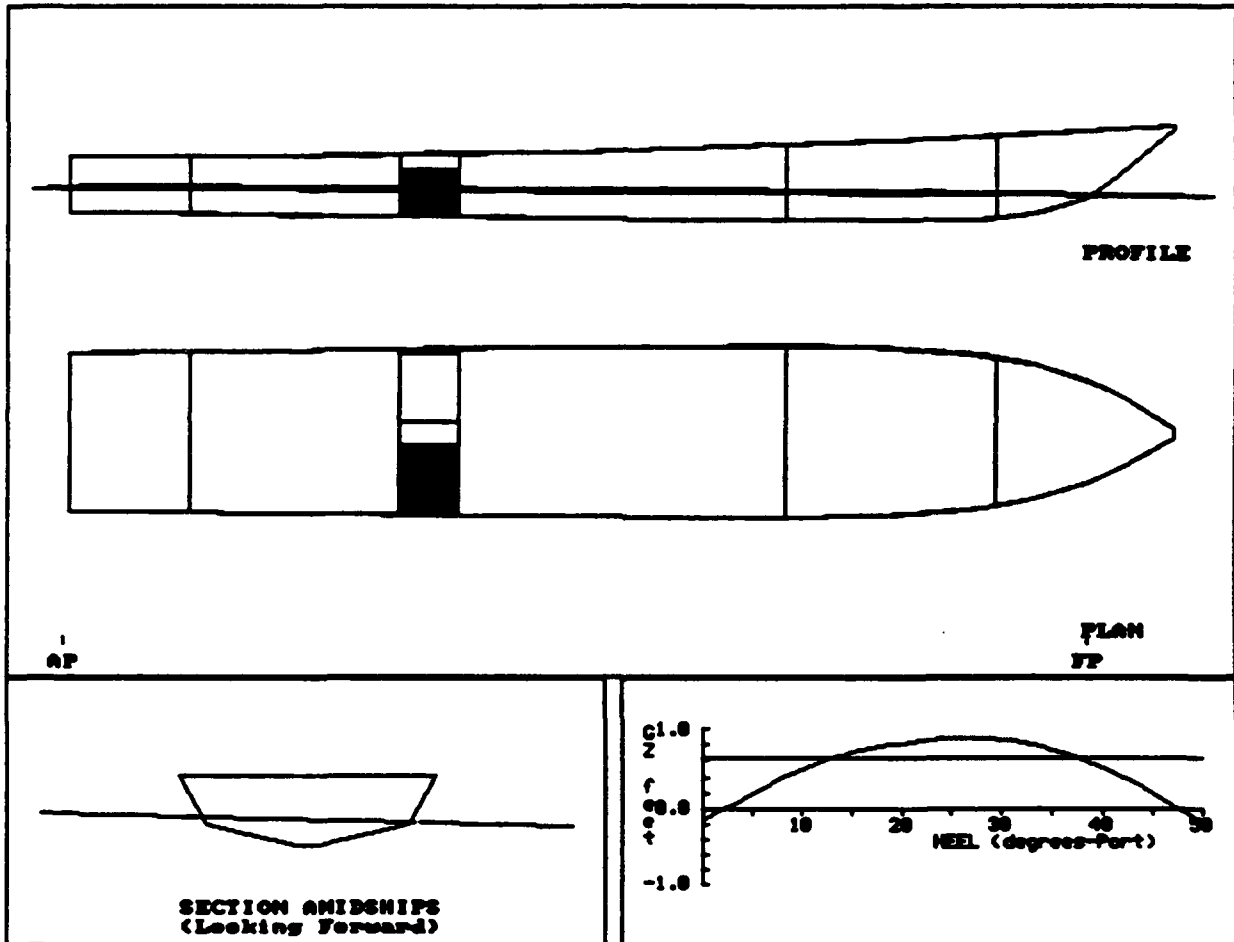

DFRTO05A:
 91' CREW BOAT A

COMPARTMENT FLOODING SUMMARY

At 2.30P Heel	PERM.	FLOODED WTR LTons	% FULL (Damaged)	% FULL (Intact)	SP.VOL. ft3/LT	OUTFLOW LTons
FO TANK STBD	0.95	2.6	FREE	98.0	40.6000	5.5
Totals		2.6				5.5

INTACT DATA

Draft at AP = 4.410 ft	Kmt = 14.060 ft	LCG = 55.475A ft-FP
Draft at FP = 3.340 ft	VCG = 9.810 ft	LCB = 55.560A ft-FP
Displacement = 103.2 LTons	Gmt = 4.250 ft	TCG = 0.000 ft-CL

DRAFT/GZ DATA

HEEL degrees	RIGHTING ARM ft	DRAFT AFT ft	DRAFT FWD ft	FLOODED WATER LTons
0.00	-0.158	4.320	3.318	2.9
5.00P	0.182	4.295	3.283	2.3
7.00P	0.314	4.283	3.248	2.1
10.00P	0.495	4.261	3.169	1.7
20.00P	0.820	3.973	2.750	0.8
30.00P	0.862	3.319	2.053	0.2
40.00P	0.518	2.600	0.820	0.0
50.00P	-0.194	1.736	-1.010	0.0

Note: Drafts are measured at A.P. and F.P along ship's centerline

GZ SUMMARY (Evaluated per IMO (SOLAS'90) Rules for Passenger Ships)
 Available Required

Static Heel Angle	2.31P deg	7.00 deg
Angle at Maximum GZ	28.00P deg	
Maximum GZ	0.882 ft	0.630 ft
Range of Positive GZ	45.14 deg	15.00 deg
Righting Area (2.31-7.00)	10.512 ft-deg	2.820 ft-deg

DPRT006A:
 91' CREW BOAT A

Imaged Compartments:
 400 FO TANK STBD

	DISPLACEMENT LTons	DRAFT AFT ft	DRAFT FWD ft	TRIM ft	HEEL deg.	UPRIGHT GMT ft
INTACT	103.2	4.410	3.340	1.070A	0.00	4.250
DAMAGED	102.2	4.373	3.321	1.052A	2.24P	3.945

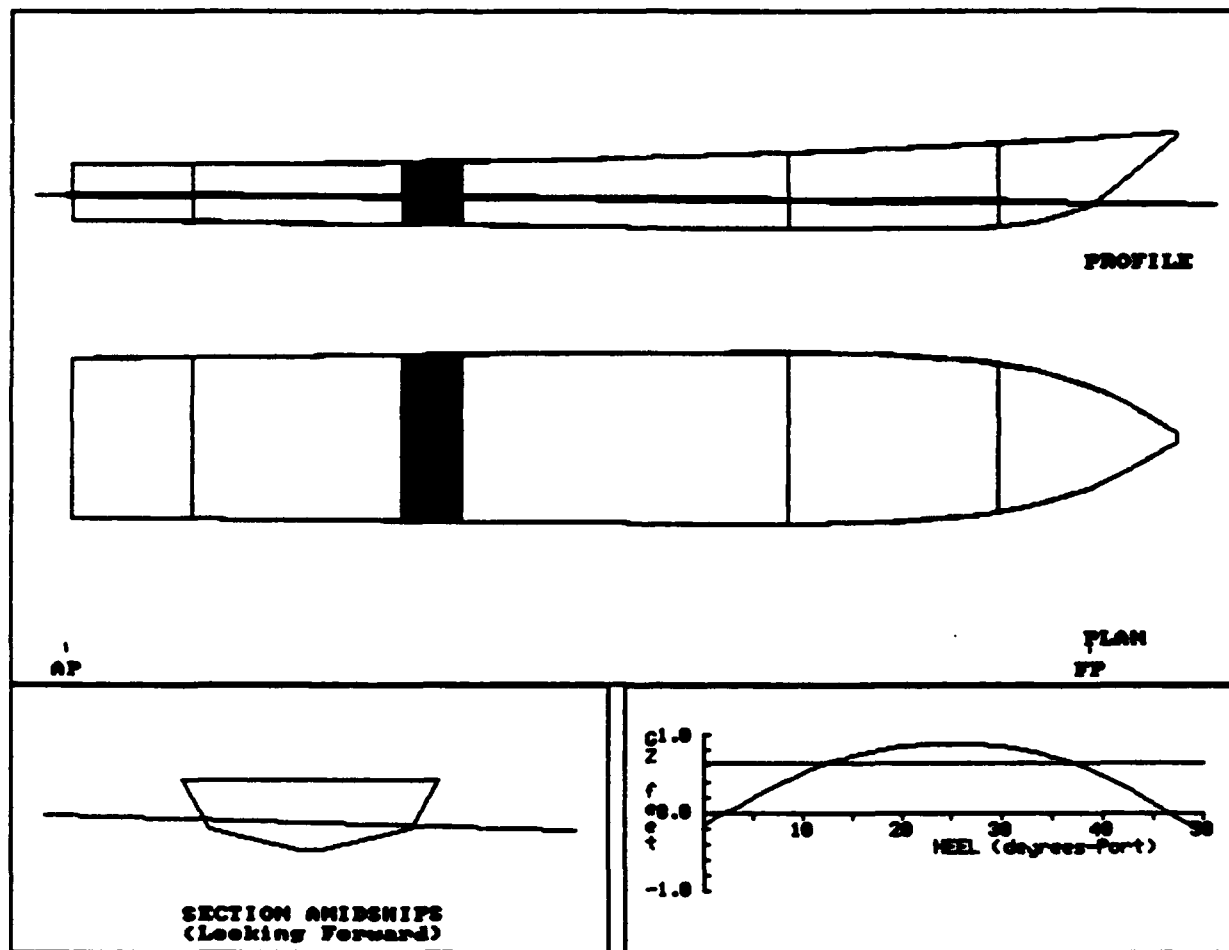

DPRT006A:
 91' CREW BOAT A

COMPARTMENT FLOODING SUMMARY

At 2.20P Heel	PERM.	FLOODED WTR LTons	% FULL (Damaged)	% FULL (Intact)	SP.VOL. ft ³ /LT	OUTFLOW LTons
400	0.95	1.8	FREE	0.0	----	----
FO TANK STBD	0.95	2.7	FREE	98.0	40.6000	5.5
Totals		4.5				5.5

INTACT DATA

Draft at AP = 4.410 ft	Kmt = 14.060 ft	LCG = 55.475A ft-FP
Draft at FP = 3.340 ft	VCG = 9.810 ft	LCB = 55.560A ft-FP
Displacement = 103.2 LTons	GMT = 4.250 ft	TCG = 0.000 ft-CL

DRAFT/GZ DATA

HEEL degrees	RIGHTING ARM ft	DRAFT AFT ft	DRAFT FWD ft	FLOODED WATER LTons
0.00	-0.155	4.384	3.334	4.8
5.00P	0.189	4.358	3.298	4.1
7.00P	0.322	4.346	3.264	3.8
10.00P	0.508	4.323	3.186	3.5
20.00P	0.848	4.044	2.766	2.5
30.00P	0.853	3.428	2.064	2.2
40.00P	0.469	2.767	0.820	2.1
50.00P	-0.270	1.971	-1.015	2.0

Note: Drafts are measured at A.P. and F.P along ship's centerline

GZ SUMMARY (Evaluated per IMO (SOLAS'90) Rules for Passenger Ships)
 Available Required

Static Heel Angle	2.24P deg	7.00 deg
Angle at Maximum GZ	26.00P deg	
Maximum GZ	0.893 ft	0.630 ft
Range of Positive GZ	44.32 deg	15.00 deg
Righting Area (2.24-1.00)	10.855 ft-deg	2.820 ft-deg

DPRT007A:
 91' CREW BOAT A

Damaged Compartments:
 500 ENG ROOM

	DISPLACEMENT LTons	DRAFT AFT ft	DRAFT FWD ft	TRIM ft	HEEL deg.	UPRIGHT Gmt ft
INTACT	103.2	4.410	3.340	1.070A	0.00	4.250
DAMAGED	141.6	6.580	2.505	4.075A	0.00	2.449

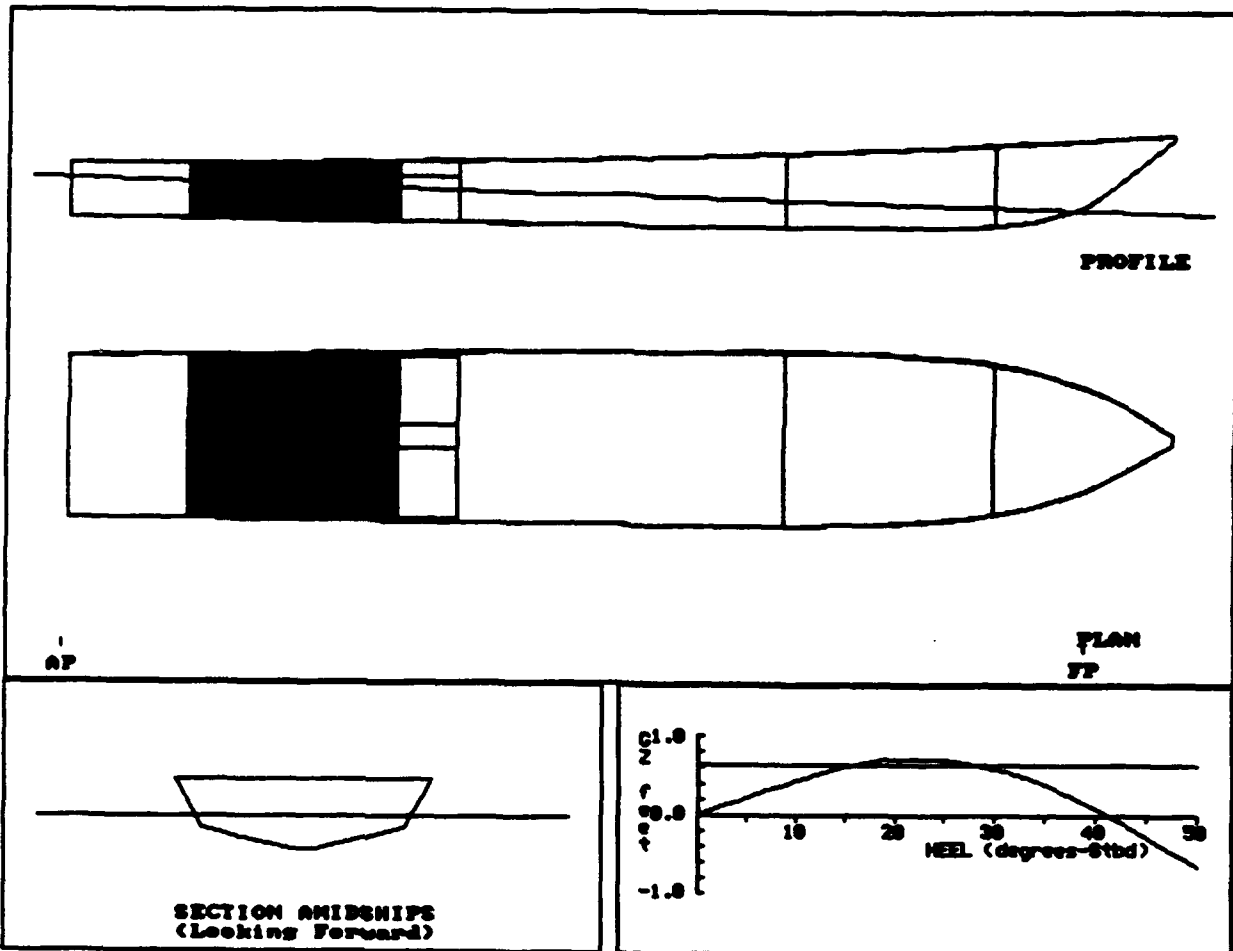

DEPT007A:
 91' CREW BOAT A

COMPARTMENT FLOODING SUMMARY

At 0.0o Heel	PERM.	FLOODED WTR LTons	% FULL (Damaged)	% FULL (Intact)	SP.VOL. ft3/LT	OUTFLOW LTons
500 ENG ROOM	0.85	38.3	FREE	0.0	----	----
Totals		38.3				

INTACT DATA

Draft at AP = 4.410 ft	KMt = 14.060 ft	LCG = 55.475A ft-FP
Draft at FP = 3.340 ft	VCG = 9.810 ft	LCB = 55.560A ft-FP
Displacement = 103.2 LTons	GMT = 4.250 ft	TCG = 0.000 ft-CL

DRAFT/GZ DATA

HEEL degrees	RIGHTING ARM ft	DRAFT AFT ft	DRAFT FWD ft	FLOODED WATER LTons
0.00	0.000	6.580	2.505	38.3
5.00S	0.215	6.565	2.489	38.3
7.00S	0.304	6.562	2.461	38.3
10.00S	0.433	6.554	2.395	38.3
20.00S	0.711	6.623	1.867	38.3
30.00S	0.591	7.015	0.712	37.8
40.00S	0.086	7.754	-1.033	37.6
50.00S	-0.651	9.010	-3.689	37.6

Note: Drafts are measured at A.P. and F.P along ship's centerline

GZ SUMMARY (Evaluated per IMO (SOLAS'90) Rules for Passenger Ships)

	Available	Required
Static Heel Angle	0.00 deg	7.00 deg
Angle at Maximum GZ	23.00S deg	
Maximum GZ	0.721 ft	0.630 ft
Range of Positive GZ	41.26 deg	15.00 deg
Gmt (upright damaged)	2.449 ft	
Righting Area (0.00-7.00)	9.577 ft-deg	2.820 ft-deg

DPR008A:
 91' CREW BOAT A

Imaged Compartments:
 600 LAZARETT

	DISPLACEMENT LTons	DRAFT AFT ft	DRAFT FWD ft	TRIM ft	HEEL deg.	UPRIGHT Gmt ft
INTACT	103.2	4.410	3.340	1.070A	0.00	4.250
DAMAGED	130.6	6.697	1.703	4.994A	0.00	2.918

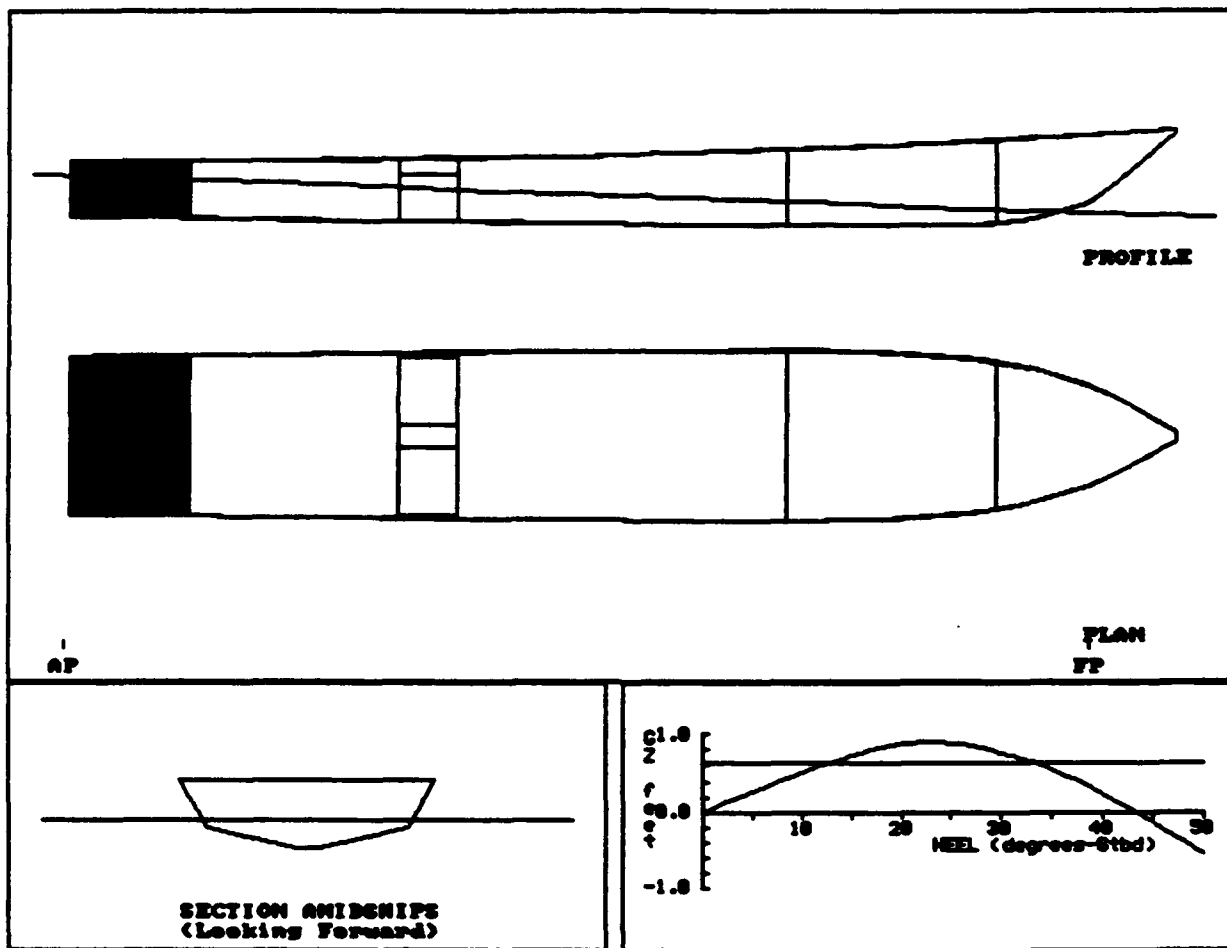

DFRTOOSA:
 91' CREW BOAT A

COMPARTMENT FLOODING SUMMARY

At 0.0o Heel	PERM.	FLOODED WTR LTons	% FULL (Damaged)	% FULL (Intact)	SP.VOL. ft3/LT	OUTFLOW LTons
600 LAZARETT	0.95	27.4	FREE	0.0	----	----
Totals		27.4				

INTACT DATA

Draft at AP = 4.410 ft	KMt = 14.060 ft	LCG = 55.475A ft-FP
Draft at FP = 3.340 ft	VCG = 9.810 ft	LCB = 55.560A ft-FP
Displacement = 103.2 LTons	GMT = 4.250 ft	TCG = 0.000 ft-CL

DRAFT/GZ DATA

HEEL degrees	RIGHTING ARM ft	DRAFT AFT ft	DRAFT FWD ft	FLOODED WATER LTons
0.00	0.000	6.697	1.703	27.4
5.00S	0.256	6.695	1.670	27.4
7.00S	0.355	6.696	1.633	27.5
10.00S	0.503	6.700	1.547	27.6
20.00S	0.882	6.740	0.964	27.0
30.00S	0.770	7.026	-0.232	26.0
40.00S	0.246	7.708	-2.162	25.8
50.00S	-0.555	9.092	-5.394	26.2

Note: Drafts are measured at A.P. and F.P along ship's centerline

GZ SUMMARY (Evaluated per IMO (SOLAS'90) Rules for Passenger Ships)

	Available	Required
Static Heel Angle	0.00 deg	7.00 deg
Angle at Maximum GZ	24.00S deg	
Maximum GZ	0.903 ft	0.630 ft
Range of Positive GZ	43.28 deg	15.00 deg
Gmt (upright damaged)	2.918 ft	
Righting Area (0.00-7.00)	11.514 ft-deg	2.820 ft-deg

RTRM001B:
 91' CREW BOAT A

amaged Compartments:

100

	DISPLACEMENT LTons	DRAFT AFT ft	DRAFT FWD ft	TRIM ft	HEEL deg.	UPRIGHT Gmt ft
INTACT	89.1	3.870	3.280	0.590A	0.00	4.960
DAMAGED	90.0	3.806	3.415	0.391A	0.00	4.956

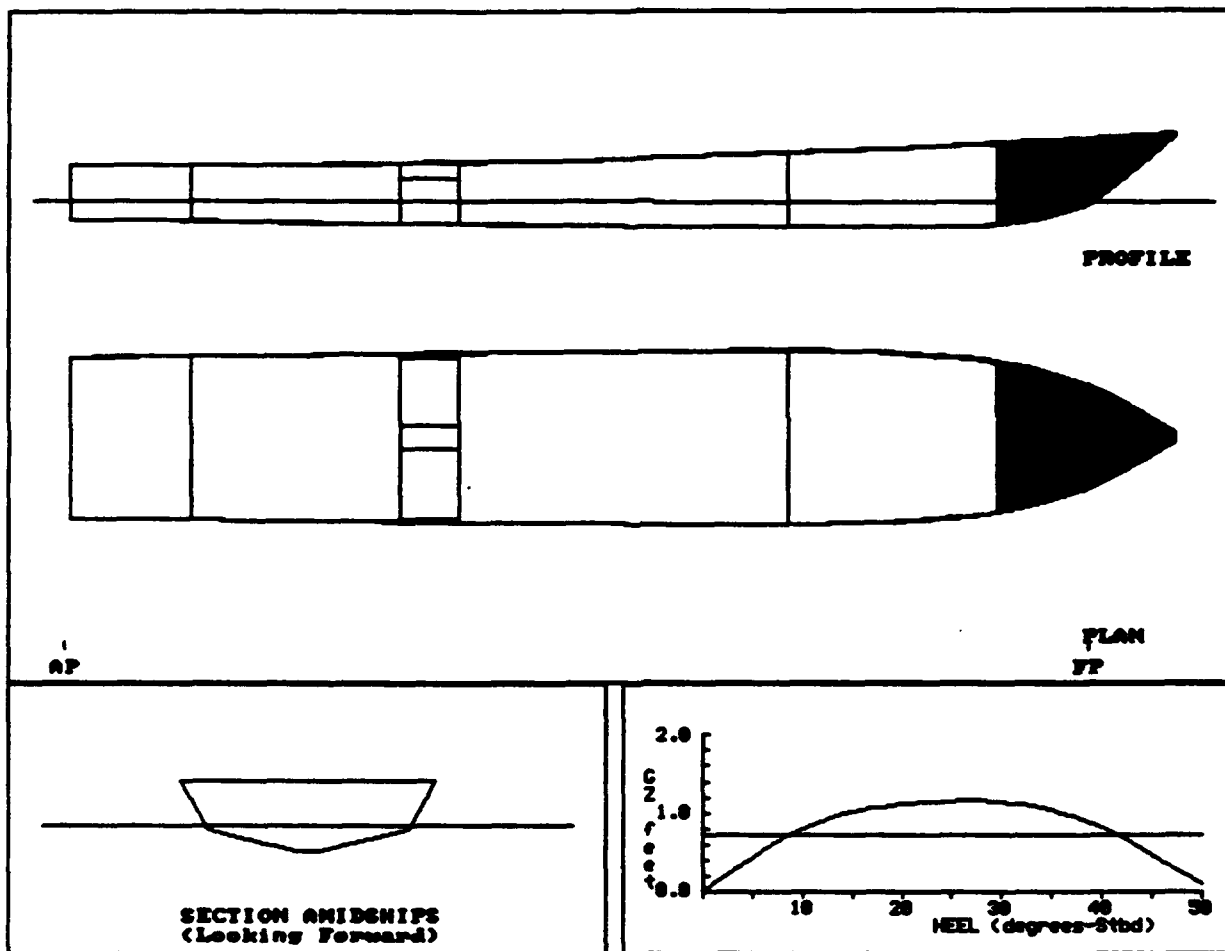

RTRM001B:
 91' CREW BOAT A

COMPARTMENT FLOODING SUMMARY

At 0.0o Heel	PERM.	FLOODED WTR LTons	% FULL (Damaged)	% FULL (Intact)	SP.VOL. ft3/LT	OUTFLOW LTons
100	0.95	0.9	FREE	0.0	----	----
Totals		0.9				

INTACT DATA

Draft at AP = 3.870 ft	Kmt = 15.200 ft	LCG = 54.733A ft-FP
Draft at FP = 3.280 ft	VCG = 10.240 ft	LCB = 54.784A ft-FP
Displacement = 89.1 LTons	GMT = 4.960 ft	TCG = 0.000 ft-CL

DRAFT/GZ DATA

HEEL degrees	RIGHTING ARM ft	DRAFT AFT ft	DRAFT FWD ft	FLOODED WATER LTons
0.00	0.000	3.806	3.415	0.9
5.00S	0.428	3.826	3.349	0.8
7.00S	0.590	3.826	3.308	0.8
10.00S	0.798	3.801	3.237	0.8
20.00S	1.105	3.485	2.817	0.6
30.00S	1.139	2.765	2.127	0.3
40.00S	0.819	1.834	0.914	0.0
50.00S	0.090	0.641	-0.872	0.0

Note: Drafts are measured at A.P. and F.P along ship's centerline

GZ SUMMARY (Evaluated per IMO (SOLAS'90) Rules for Passenger Ships)
 Available Required

Static Heel Angle	0.00 deg	7.00 deg
Angle at Maximum GZ	28.00S deg	
Maximum GZ	1.155 ft	0.710 ft
Range of Positive GZ	50.00 deg	15.00 deg
Gmt (upright damaged)	4.956 ft	
Righting Area (0.00- 3 .00)	16.323 ft-deg	2.820 ft-deg

RTRM002B:
 91' CREW BOAT A

Damaged Compartments:
 200

	DISPLACEMENT LTons	DRAFT AFT ft	DRAFT FWD ft	TRIM ft	HEEL deg.	UPRIGHT Gmt ft
INTACT	89.1	3.870	3.280	0.590A	0.00	4.960
DAMAGED	106.9	3.273	4.988	1.715F	0.00	4.715

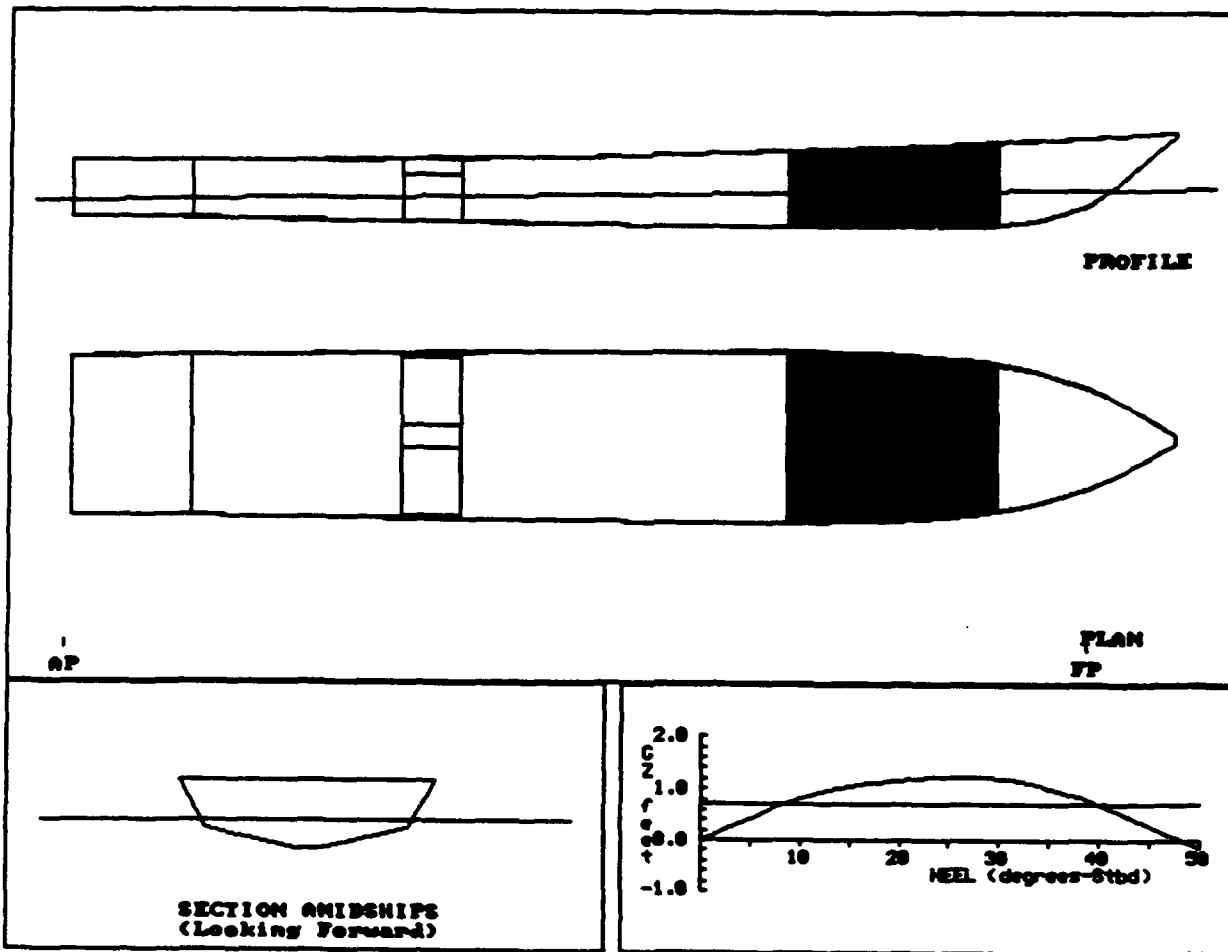

**RTM002B:
 91' CREW BOAT A**

COMPARTMENT FLOODING SUMMARY

At 0.0o Heel	PERM.	FLOODED WTR LTons	% FULL (Damaged)	% FULL (Intact)	SP.VOL. ft3/LT	OUTFLOW LTons
200	0.95	17.8	FREE	0.0	----	----
Totals		17.8				

INTACT DATA

Draft at AP = 3.870 ft KMT = 15.200 ft LCG = 54.733A ft-FP
 Draft at FP = 3.280 ft VCG = 10.240 ft LCB = 54.784A ft-FP
 Displacement = 89.1 LTons GMT = 4.960 ft TCG = 0.000 ft-CL

DRAFT/GZ DATA

HEEL degrees	RIGHTING ARM ft	DRAFT AFT ft	DRAFT FWD ft	FLOODED WATER LTons
0.00	0.000	3.273	4.988	17.8
5.00S	0.415	3.269	4.967	17.8
7.00S	0.587	3.262	4.951	17.8
10.00S	0.815	3.234	4.910	17.8
20.00S	1.164	2.848	4.658	18.1
30.00S	1.204	2.042	4.141	18.5
40.00S	0.707	0.870	3.528	20.0
50.00S	-0.159	-0.613	2.566	20.5

Note: Drafts are measured at A.P. and F.P along ship's centerline

GZ SUMMARY (Evaluated per IMO (SOLAS'90) Rules for Passenger Ships)
 Available Required

Static Heel Angle	0.00 deg	7.00 deg
Angle at Maximum GZ	28.00S deg	
Maximum GZ	1.237 ft	0.710 ft
Range of Positive GZ	48.24 deg	15.00 deg
Gmt (upright damaged)	4.715 ft	
Righting Area (0.00-3.00)	16.800 ft-deg	2.820 ft-deg

RTRN003B:
 91' CREW BOAT A

Damaged Compartments:
 300

	DISPLACEMENT LTons	DRAFT AFT ft	DRAFT FWD ft	TRIM ft	HEEL deg.	UPRIGHT Gmt ft
INTACT	89.1	3.870	3.280	0.590A	0.00	4.960
DAMAGED	139.7	4.228	5.448	1.220F	0.00	2.145

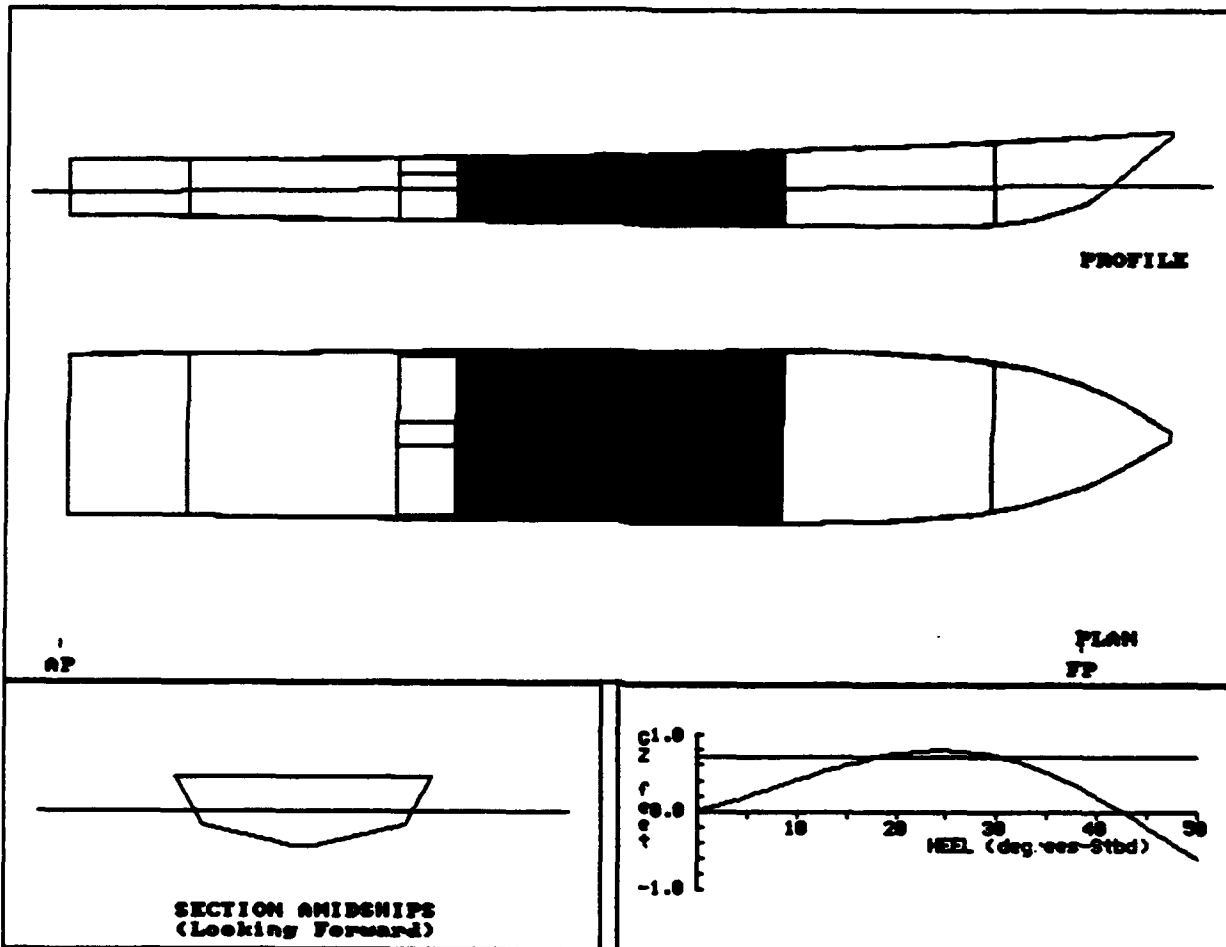

RTRN004B:
 91' CREW BOAT A

Imaged Compartments:
 400

	DISPLACEMENT LTons	DRAFT AFT ft	DRAFT FWD ft	TRIM ft	HEEL deg.	UPRIGHT GMT ft
INTACT	89.1	3.870	3.280	0.590A	0.00	4.960
DAMAGED	90.7	3.926	3.294	0.632A	0.00	4.916

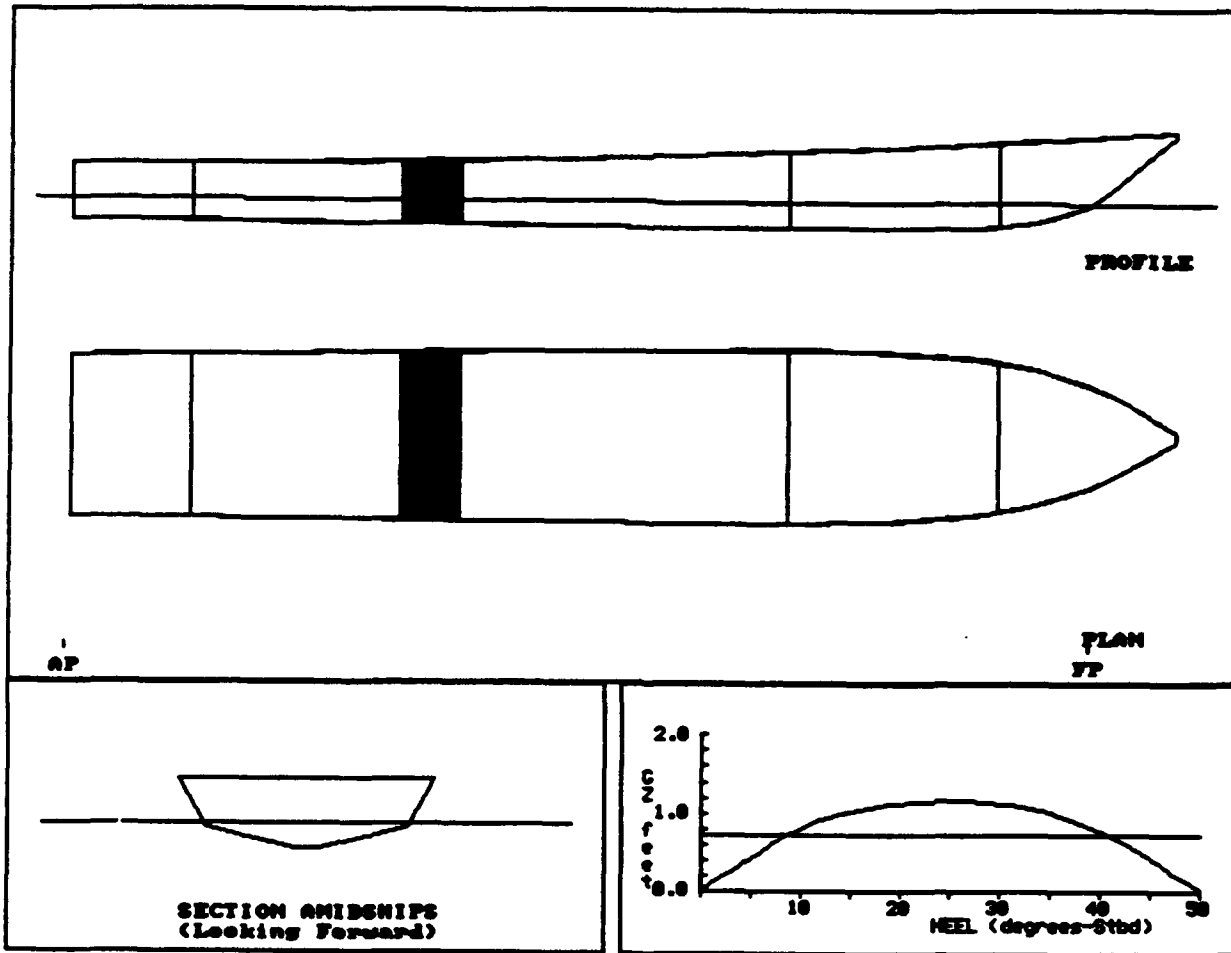

RTRN004B:
 91' CREW BOAT A

COMPARTMENT FLOODING SUMMARY

At 0.0o Heel	PERM.	FLOODED WTR LTons	% FULL (Damaged)	% FULL (Intact)	SP.VOL. ft3/LT	OUTFLO LTons
400	0.95	1.6	FREE	0.0	----	----
Totals		1.6				

INTACT DATA

Draft at AP = 3.870 ft	KMt = 15.200 ft	LCG = 54.733A ft-FP
Draft at FP = 3.280 ft	VCG = 10.240 ft	LCB = 54.784A ft-FP
Displacement = 89.1 LTons	GMT = 4.960 ft	TCG = 0.000 ft-CL

DRAFT/GZ DATA

HEEL degrees	RIGHTING ARM ft	DRAFT AFT ft	DRAFT FWD ft	FLOODED WATER LTons
0.00	0.000	3.926	3.294	1.6
5.00S	0.425	3.935	3.245	1.6
7.00S	0.586	3.933	3.206	1.6
10.00S	0.797	3.907	3.140	1.6
20.00S	1.122	3.588	2.740	1.5
30.00S	1.127	2.879	2.083	1.7
40.00S	0.770	1.972	0.908	1.7
50.00S	0.016	0.831	-0.868	1.7

Note: Drafts are measured at A.P. and F.P along ship's centerline

GZ SUMMARY (Evaluated per IMO (SOLAS'90) Rules for Passenger Ships)

	Available	Required
Static Heel Angle	0.00 deg	7.00 deg
Angle at Maximum GZ	26.00S deg	
Maximum GZ	1.159 ft	0.710 ft
Range of Positive GZ	50.00 deg	15.00 deg
Gmt (upright damaged)	4.916 ft	
Righting Area (0.00-7.00)	16.424 ft-deg	2.820 ft-deg

RTRN005B:
 91' CREW BOAT A

Damaged Compartments:
 FO TANK STBD

	DISPLACEMENT LTons	DRAFT AFT ft	DRAFT FWD ft	TRIM ft	HEEL deg.	UPRIGHT CNT ft
INTACT	89.1	3.870	3.280	0.590A	0.00	4.960
DAMAGED	91.4	3.949	3.292	0.657A	1.57S	4.496

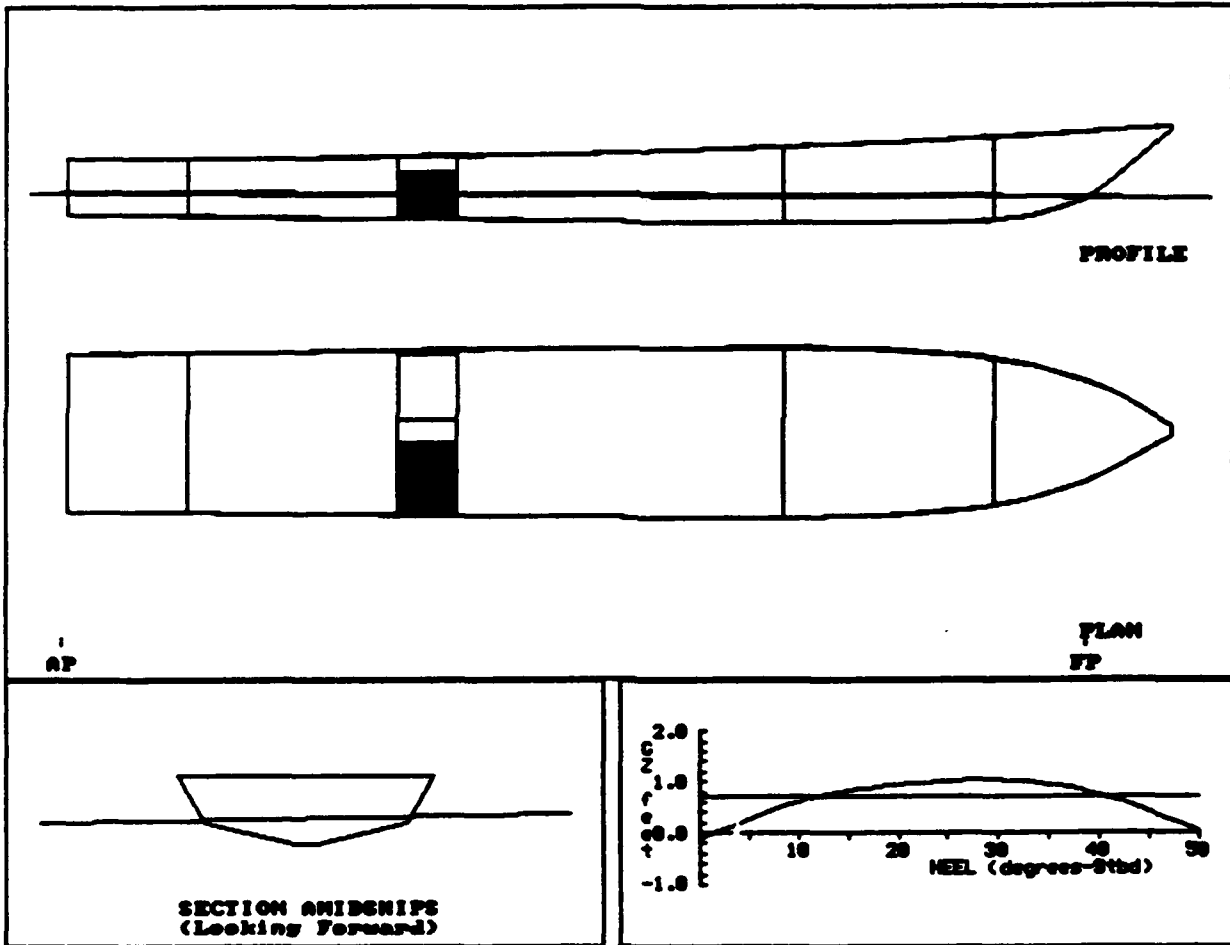

RTRN005B:
 91' CREW BOAT A

COMPARTMENT FLOODING SUMMARY

At 1.6oS Heel	PERM.	FLOODED WTR LTons	% FULL (Damaged)	% FULL (Intact)	SP.VOL. ft ³ /LT	OUTFLOW LTons
FO TANK STBD	0.95	2.8	FREE	10.0	40.6000	0.6
Totals		2.8				0.6

INTACT DATA

Draft at AP = 3.870 ft KMT = 15.200 ft LCG = 54.733A ft-FP
 Draft at FP = 3.280 ft VCG = 10.240 ft LCB = 54.784A ft-FP
 Displacement = 89.1 LTons GMT = 4.960 ft TCG = 0.000 ft-CL

DRAFT/GZ DATA

HEEL degrees	RIGHTING ARM ft	DRAFT AFT ft	DRAFT FWD ft	FLOODED WATER LTons
0.00	-0.123	3.943	3.298	2.6
5.00S	0.266	3.965	3.266	3.2
7.00S	0.415	3.976	3.225	3.5
10.00S	0.613	3.969	3.157	3.8
20.00S	0.935	3.711	2.766	4.9
30.00S	1.032	3.039	2.100	5.2
40.00S	0.743	2.212	0.906	5.3
50.00S	0.029	1.170	-0.874	5.2

Note: Drafts are measured at A.P. and F.P along ship's centerline

GZ SUMMARY (Evaluated per IMO (SOLAS'90) Rules for Passenger Ships)

	Available	Required
Static Heel Angle	1.57S deg	7.00 deg
Angle at Maximum GZ	30.00S deg	
Maximum GZ	1.036 ft	0.710 ft
Range of Positive GZ	48.43 deg	15.00 deg
Righting Area (1.57-3.00)	12.661 ft-deg	2.820 ft-deg

RTRN006B:
 91' CREW BOAT A

amaged Compartments:
 400 FO TANK STBD

	DISPLACEMENT LTONS	DRAFT AFT ft	DRAFT FWD ft	TRIM ft	HEEL deg.	UPRIGHT GMT ft
INTACT	89.1	3.870	3.280	0.590A	0.00	4.960
DAMAGED	93.1	4.008	3.306	0.702A	1.60S	4.528

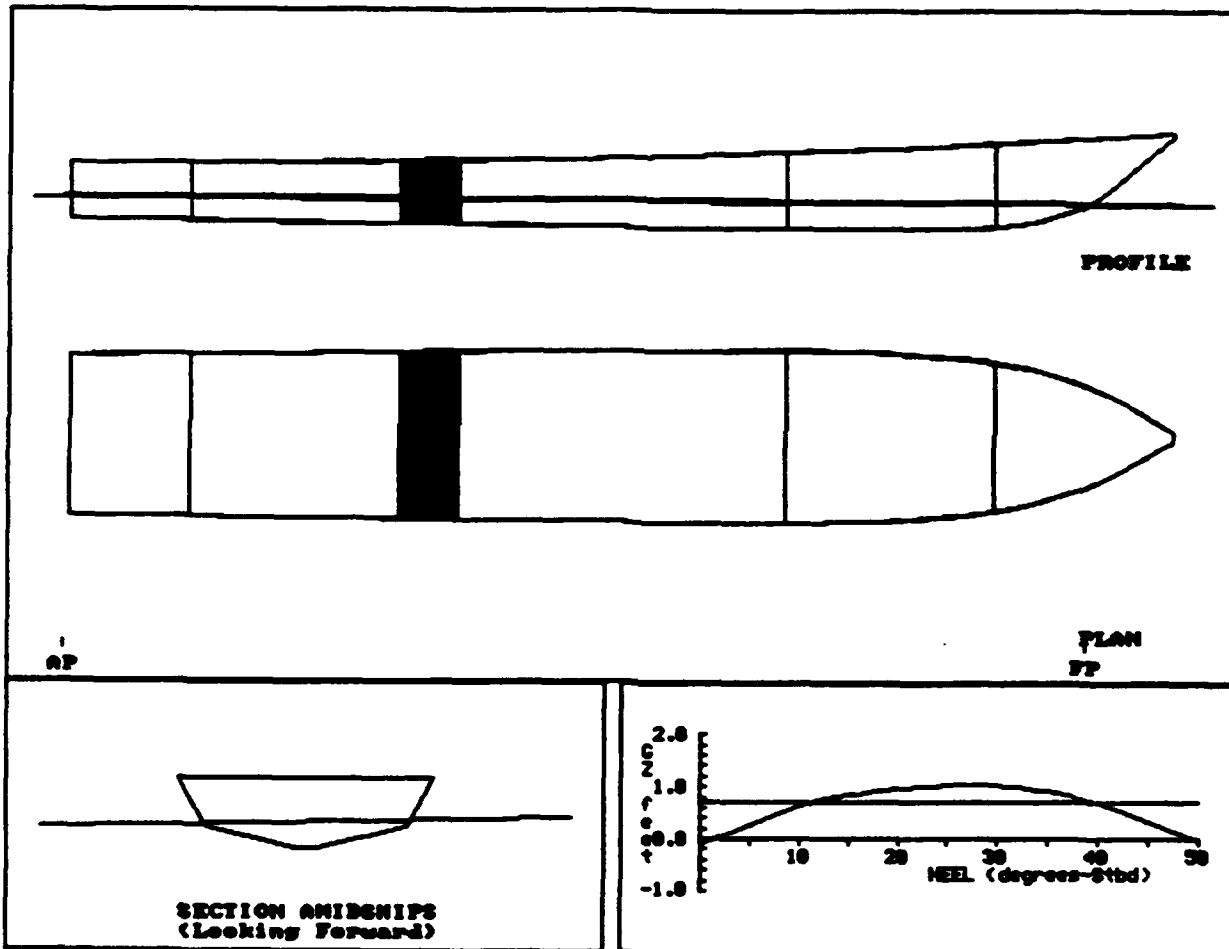

RTRN006B:
 91' CREW BOAT A

COMPARTMENT FLOODING SUMMARY

At 1.6oS Heel	PERM.	FLOODED WTR LTons	% FULL (Damaged)	% FULL (Intact)	SP.VOL. ft ³ /LT	OUTFLOW LTons
400	0.95	1.6	FREE	0.0	----	----
FO TANK STBD	0.95	2.9	FREE	10.0	40.6000	0.6
Totals		4.5				0.6

INTACT DATA

Draft at AP = 3.870 ft Kmt = 15.200 ft LCG = 54.733A ft-FP
 Draft at FP = 3.280 ft VCG = 10.240 ft LCB = 54.784A ft-FP
 Displacement = 89.1 LTons GMT = 4.960 ft TCG = 0.000 ft-CL

DRAFT/GZ DATA

HEEL degrees	RIGHTING ARM ft	DRAFT AFT ft	DRAFT FWD ft	FLOODED WATER LTons
0.00	-0.127	4.002	3.312	4.3
5.00S	0.267	4.024	3.281	4.9
7.00S	0.418	4.035	3.241	5.2
10.00S	0.622	4.029	3.173	5.5
20.00S	0.964	3.789	2.771	6.5
30.00S	1.027	3.140	2.110	7.1
40.00S	0.691	2.369	0.906	7.3
50.00S	-0.050	1.393	-0.878	7.2

Note: Drafts are measured at A.P. and F.P along ship's centerline

GZ SUMMARY (Evaluated per IMO (SOLAS'90) Rules for Passenger Ships)
 Available Required

Static Heel Angle	1.60S deg	7.00 deg
Angle at Maximum GZ	28.00S deg	
Maximum GZ	1.040 ft	0.710 ft
Range of Positive GZ	48.40 deg	15.00 deg
Righting Area (1.60-7.00)	12.942 ft-deg	2.820 ft-deg

RTRN007B:
 91' CREW BOAT A

Damaged Compartments:
 500 ENG ROOM

	DISPLACEMENT LTons	DRAFT AFT ft	DRAFT FWD ft	TRIM ft	HEEL deg.	UPRIGHT GMT ft
INTACT	89.1	3.870	3.280	0.590A	0.00	4.960
DAMAGED	121.5	5.722	2.568	3.154A	0.00	2.703

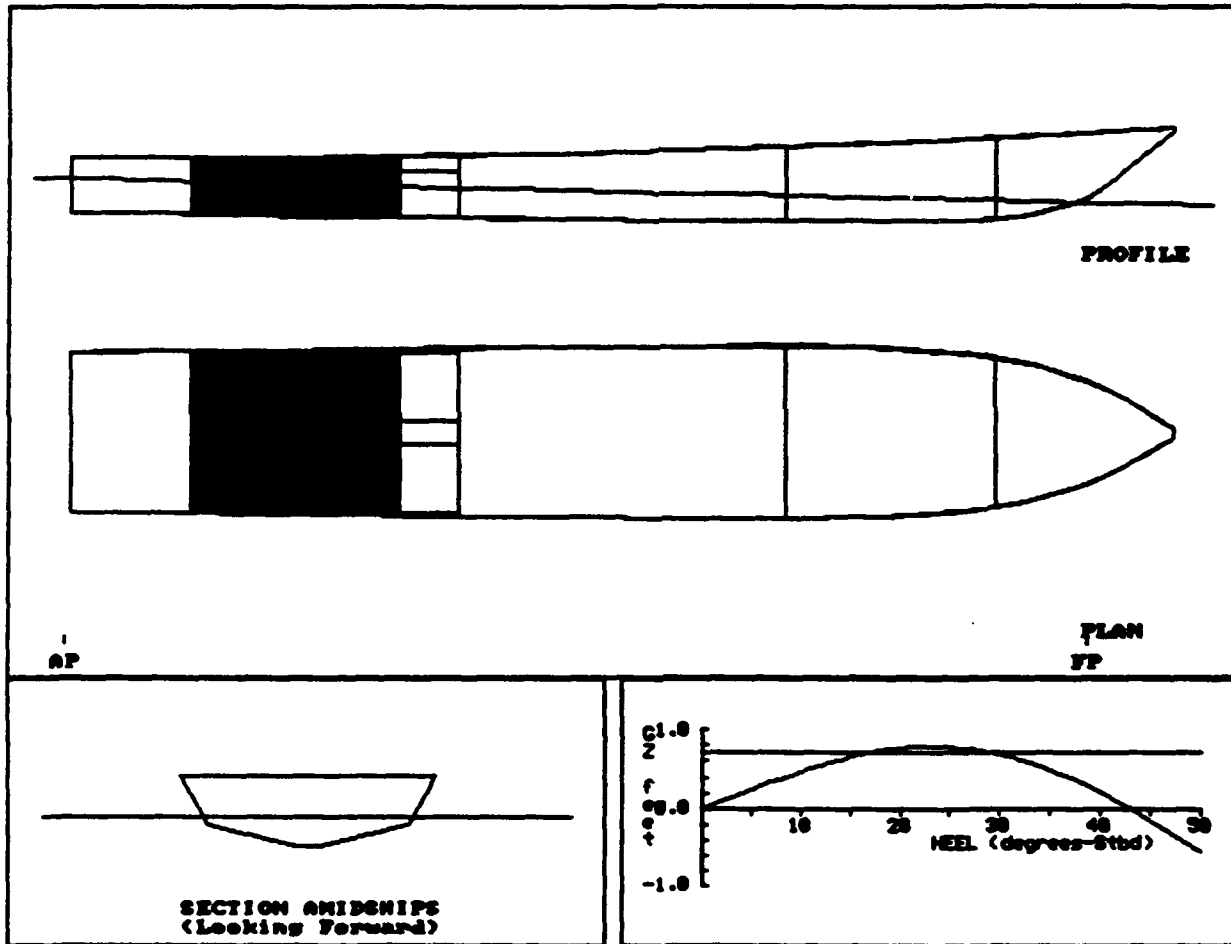

RTRN007B:
 91' CREW BOAT A

COMPARTMENT FLOODING SUMMARY

At 0.0o Heel	PERM.	FLOODED WTR LTons	% FULL (Damaged)	% FULL (Intact)	SP.VOL. ft3/LT	OUTFLOW LTons
500 ENG ROOM	0.85	32.3	FREE	0.0	----	----
Totals		32.3				

INTACT DATA

Draft at AP = 3.870 ft	KMT = 15.200 ft	LCG = 54.733A ft-FP
Draft at FP = 3.280 ft	VCG = 10.240 ft	LCB = 54.784A ft-FP
Displacement = 89.1 LTons	GMT = 4.960 ft	TCG = 0.000 ft-CL

DRAFT/GZ DATA

HEEL degrees	RIGHTING ARM ft	DRAFT AFT ft	DRAFT FWD ft	FLOODED WATER LTons
0.00	0.000	5.722	2.568	32.3
5.00S	0.235	5.712	2.546	32.3
7.00S	0.328	5.709	2.513	32.3
10.00S	0.460	5.702	2.440	32.3
20.00S	0.770	5.610	1.962	32.1
30.00S	0.682	5.561	0.975	31.8
40.00S	0.208	5.720	-0.619	31.6
50.00S	-0.554	6.187	-3.087	31.6

Note: Drafts are measured at A.P. and F.P along ship's centerline

GZ SUMMARY (Evaluated per IMO (SOLAS'90) Rules for Passenger Ships)

	Available	Required
Static Heel Angle	0.00 deg	7.00 deg
Angle at Maximum GZ	24.00S deg	
Maximum GZ	0.788 ft	0.710 ft
Range of Positive GZ	42.96 deg	15.00 deg
Gmt (upright damaged)	2.703 ft	
Righting Area (0.00-%.00)	10.286 ft-deg	2.820 ft-deg

RTRN008B:
91' CREW BOAT A

amaged Compartments:
 600 LAZARETT

	DISPLACEMENT LTons	DRAFT AFT ft	DRAFT FWD ft	TRIM ft	HEEL deg.	UPRIGHT Gmt ft
INTACT	89.1	3.870	3.280	0.590A	0.00	4.960
DAMAGED	111.6	5.775	1.913	3.863A	0.00	3.278

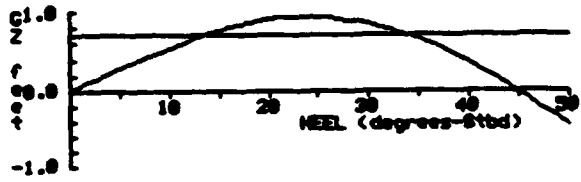
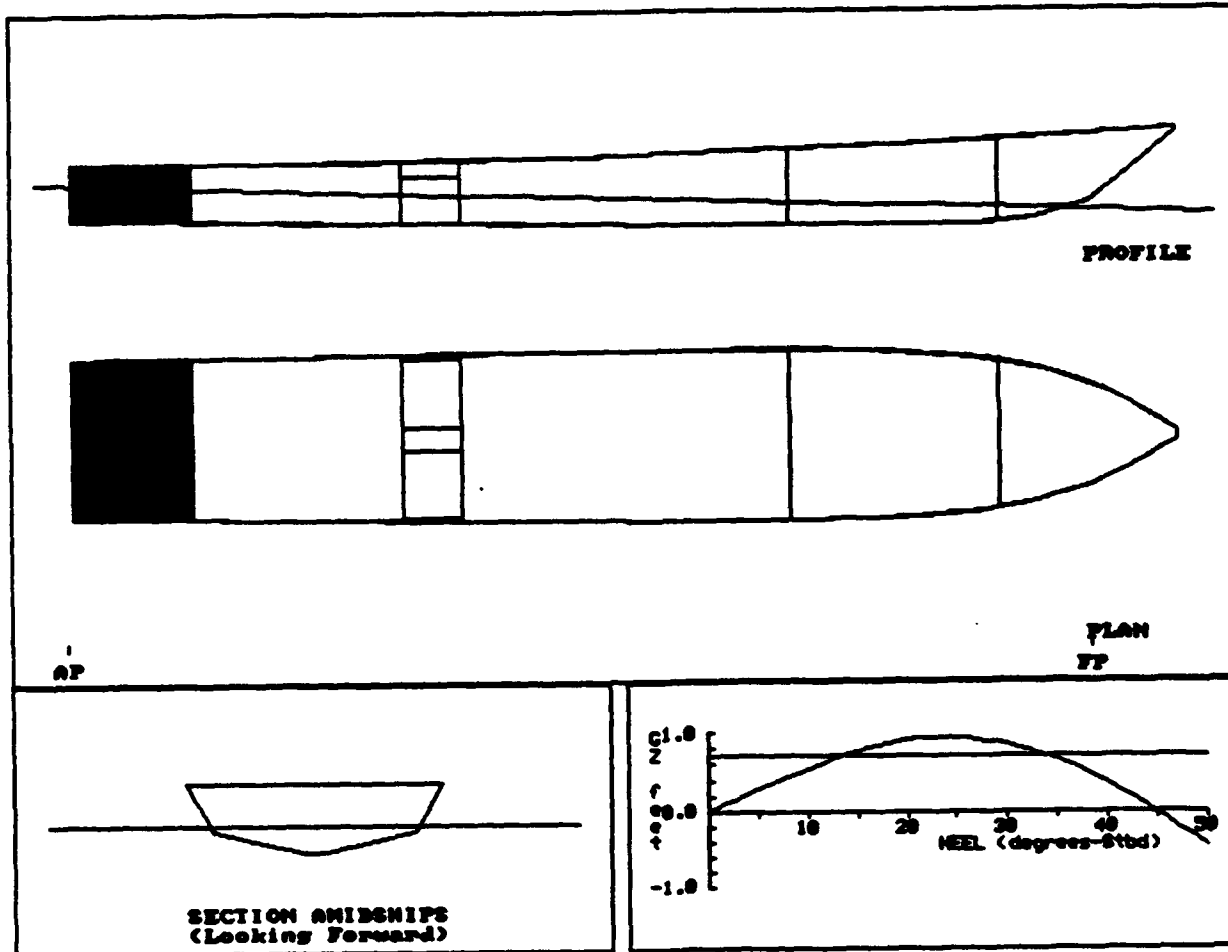

RTRN008B:
91' CREW BOAT A

COMPARTMENT FLOODING SUMMARY

At 0.0o Heel	PERM.	FLOODED WTR LTons	% FULL (Damaged)	% FULL (Intact)	SP.VOL. ft3/LT	OUTFLOW LTons
600 LAZARETT	0.95	22.5	FREE	0.0	----	----
Totals		22.5				

INTACT DATA

Draft at AP = 3.870 ft	Kmt = 15.200 ft	LCG = 54.733A ft-FP
Draft at FP = 3.280 ft	VCG = 10.240 ft	LCB = 54.784A ft-FP
Displacement = 89.1 LTons	Gmt = 4.960 ft	TCG = 0.000 ft-CL

DRAFT/GZ DATA

HEEL degrees	RIGHTING ARM ft	DRAFT AFT ft	DRAFT FWD ft	FLOODED WATER LTons
0.00	0.000	5.775	1.913	22.5
5.00S	0.283	5.768	1.883	22.5
7.00S	0.391	5.770	1.841	22.5
10.00S	0.547	5.774	1.749	22.6
20.00S	0.914	5.677	1.213	22.4
30.00S	0.847	5.483	0.247	21.3
40.00S	0.363	5.546	-1.442	21.0
50.00S	-0.454	6.048	-4.348	21.3

Note: Drafts are measured at A.P. and F.P along ship's centerline

GZ SUMMARY (Evaluated per IMO (SOLAS'90) Rules for Passenger Ships)

	Available	Required
Static Heel Angle	0.00 deg	7.00 deg
Angle at Maximum GZ	24.00S deg	
Maximum GZ	0.942 ft	0.710 ft
Range of Positive GZ	44.69 deg	15.00 deg
Gmt (upright damaged)	3.278 ft	
Righting Area (0.00-7.00)	12.223 ft-deg	2.820 ft-deg

**APPENDIX B
HYDROSTATICS AND
DAMAGE STABILITY
OUTPUT**

91' CREW BOAT B

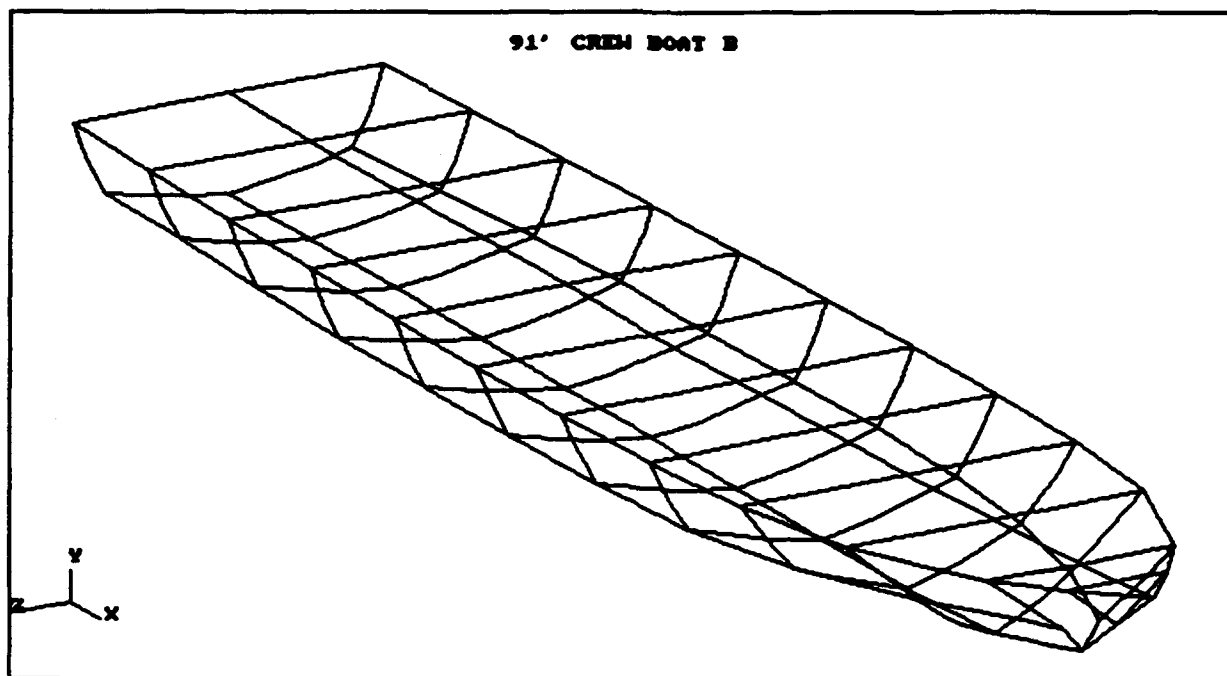

**DAMAGE STABILITY SUMMARY
 91' CREW BOAT B**

CASE No.	FILE NAME	DAMAGED COMP.	LISTING	---Intact Condition---			-----Equilibrium Condition After Damage-----					
				MN.DRAFT (ft)	VCG (ft)	GMt (ft)	HEEL (deg)	MAX.GZ (ft)	RANGE (deg)	AREA (ft-deg)	DAM.GMt (ft)	SURVIVAL
1	DPRT001A	1		3.310	7.880	5.243	0.0	1.732	50.00	17.83	5.192	Yes
2	DPRT002A	2		3.310	7.880	5.243	0.0	1.738	50.00	18.59	4.995	Yes
3	DPRT003A	3		3.310	7.880	5.243	0.0	1.361	50.00	13.06	3.192	Yes
4	DPRT004A	4		3.310	7.880	5.243	0.0	1.351	50.00	12.56	3.185	Yes
5	DPRT005A	5		3.310	7.880	5.243	0.0	1.837	50.00	19.27	5.608	Yes
6	DPRT006A	4,5		3.310	7.880	5.243	0.0	1.452	50.00	13.59	3.445	Yes
7	DPRT007A	7		3.310	7.880	5.243	0.0	1.545	50.00	15.13	4.049	Yes
8	DPRT008A	8		3.310	7.880	5.243	0.0	1.551	50.00	15.63	4.236	Yes
9	DPRT009A	8,9		3.310	7.880	5.243	0.0	1.573	50.00	16.20	4.395	Yes
10	DPRT010A	9		3.310	7.880	5.243	0.0	1.675	50.00	18.39	5.378	Yes

**HYDROSTATIC TABLES
 91' CREW BOAT B**

MOLDED DRAFT (ft)		0.500	1.000	1.500	2.000	2.500	3.000	3.500	4.000	4.500
DISP.MLD. (LTons-SW)		3	9	20	33	50	68	88	108	128
DISP.TOTAL (LTons-SW)		3	10	20	34	50	69	88	108	129
DISP.TOTAL (LTons-FW)		2	9	19	33	49	67	86	106	126
LCB (ft-FP)		56.889A	55.457A	54.873A	54.411A	54.018A	53.460A	52.922A	52.499A	52.137A
TCB (ft-CL)		0.000	0.000	0.000	0.000	0.000	0.000	0.000	0.000	0.000
KB (ft)		0.334	0.655	0.973	1.291	1.608	1.915	2.210	2.496	2.777
BMT (ft)		7.867	9.720	11.788	13.459	14.280	12.371	10.583	9.251	8.276
KMT (ft)		8.201	10.375	12.761	14.750	15.888	14.286	12.792	11.747	11.053
BML (ft)		1750.682	907.092	604.099	454.873	355.921	286.878	239.475	205.537	180.218
KML (ft)		1751.016	907.747	605.072	456.164	357.529	288.794	241.684	208.032	182.995
TPI (LTons)		0.8	1.5	2.0	2.5	2.9	3.2	3.3	3.4	3.5
MTlin (ft-LTons)		4	8	11	14	16	18	19	20	21
MTlin (LTons)		0.1	0.1	0.2	0.2	0.2	0.2	0.2	0.2	0.2
LL (ft-FP)		56.656A	54.306A	53.937A	53.627A	52.938A	51.653A	50.900A	50.426A	50.086A
W.P. AREA (ft ²)		352	613	842	1,051	1,233	1,324	1,380	1,424	1,463
WETTED SUR. (ft ²)		363	645	894	1,129	1,343	1,488	1,609	1,720	1,829
MAX. BEAM (ft)		5.532	8.737	11.795	14.631	17.340	17.865	18.194	18.536	18.878
LENGTH W.L. (ft)		82.490	84.011	85.532	87.053	88.573	90.094	91.025	91.454	91.883
Cb		0.0878	0.1652	0.2307	0.2911	0.3476	0.3968	0.4368	0.4695	0.4973
Cm		0.1289	0.2266	0.3072	0.3796	0.4480	0.5073	0.5519	0.5872	0.6163
Cp		0.6808	0.7290	0.7511	0.7668	0.7758	0.7821	0.7915	0.7996	0.8069
Cwp		0.1752	0.3052	0.4191	0.5237	0.6139	0.6592	0.6873	0.7092	0.7286
Cit		0.0086	0.0398	0.1012	0.1943	0.3076	0.3651	0.4012	0.4308	0.4591

Assumes: Sea Water at 35.0063 ft³/LT
 Fresh Water at 35.8814 ft³/LT
 Ship floating at even keel (no heel or trim)

DPRT001A:
 91' CREW BOAT B

Imaged Compartments:
 FOREPEAK

	DISPLACEMENT LTons	DRAFT AFT ft	DRAFT FWD ft	TRIM ft	HEEL deg.	UPRIGHT GMT ft
INTACT	82.1	3.620	3.000	0.620A	0.00	5.243
DAMAGED	82.2	3.614	3.011	0.603A	0.00	5.192

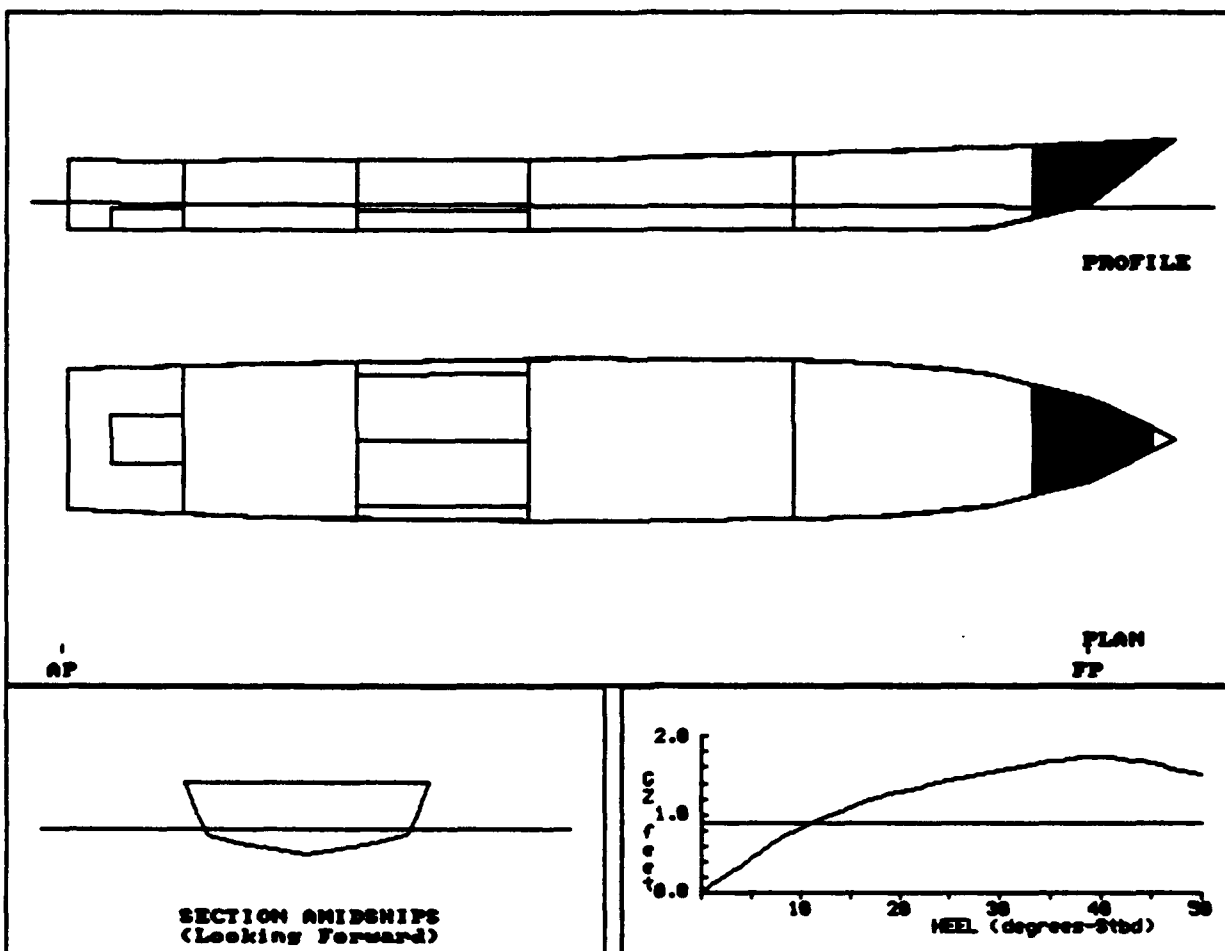

DPRT001A:
 91' CREW BOAT B

COMPARTMENT FLOODING SUMMARY

At 0.0o Heel	PERM.	FLOODED WTR LTons	% FULL (Damaged)	% FULL (Intact)	SP.VOL. ft3/LT	OUTFLOW LTons
FOREPEAK	0.95	0.1	FREE	0.0	----	----
Totals		0.1				

INTACT DATA

Draft at AP = 3.620 ft	Kmt = 13.123 ft	LCG = 54.766A ft-FP
Draft at FP = 3.000 ft	VCG = 7.880 ft	LCB = 54.805A ft-FP
Displacement = 82.1 LTons	Gmt = 5.243 ft	TCG = 0.000 ft-CL

DRAFT/GZ DATA

HEEL degrees	RIGHTING ARM ft	DRAFT AFT ft	DRAFT FWD ft	FLOODED WATER LTons
0.00	0.000	3.614	3.011	0.1
5.00S	0.444	3.610	2.977	0.1
7.00S	0.608	3.602	2.943	0.1
10.00S	0.825	3.576	2.872	0.1
20.00S	1.290	3.287	2.494	0.0
30.00S	1.550	2.653	1.878	0.0
40.00S	1.732	1.611	0.862	0.0
50.00S	1.508	0.338	-0.886	0.0

Note: Drafts are measured at A.P. and F.P along ship's centerline

GZ SUMMARY (Evaluated per IMO (SOLAS'90) Rules for Passenger Ships)
 Available Required

Static Heel Angle	0.00 deg	7.00 deg
Angle at Maximum GZ	41.00S deg	
Maximum GZ	1.732 ft	0.900 ft
Range of Positive GZ	50.00 deg	15.00 deg
Gmt (upright damaged)	5.192 ft	
Righting Area (0.00-%.00)	17.828 ft-deg	2.820 ft-deg

DPRT002A:
 91' CREW BOAT B

Imaged Compartments:
 CREW

	DISPLACEMENT LTons	DRAFT AFT ft	DRAFT FWD ft	TRIM ft	HEEL deg.	UPRIGHT GMT ft
INTACT	82.1	3.620	3.000	0.620A	0.00	5.243
DAMAGED	99.2	2.961	4.769	1.808F	0.00	4.995

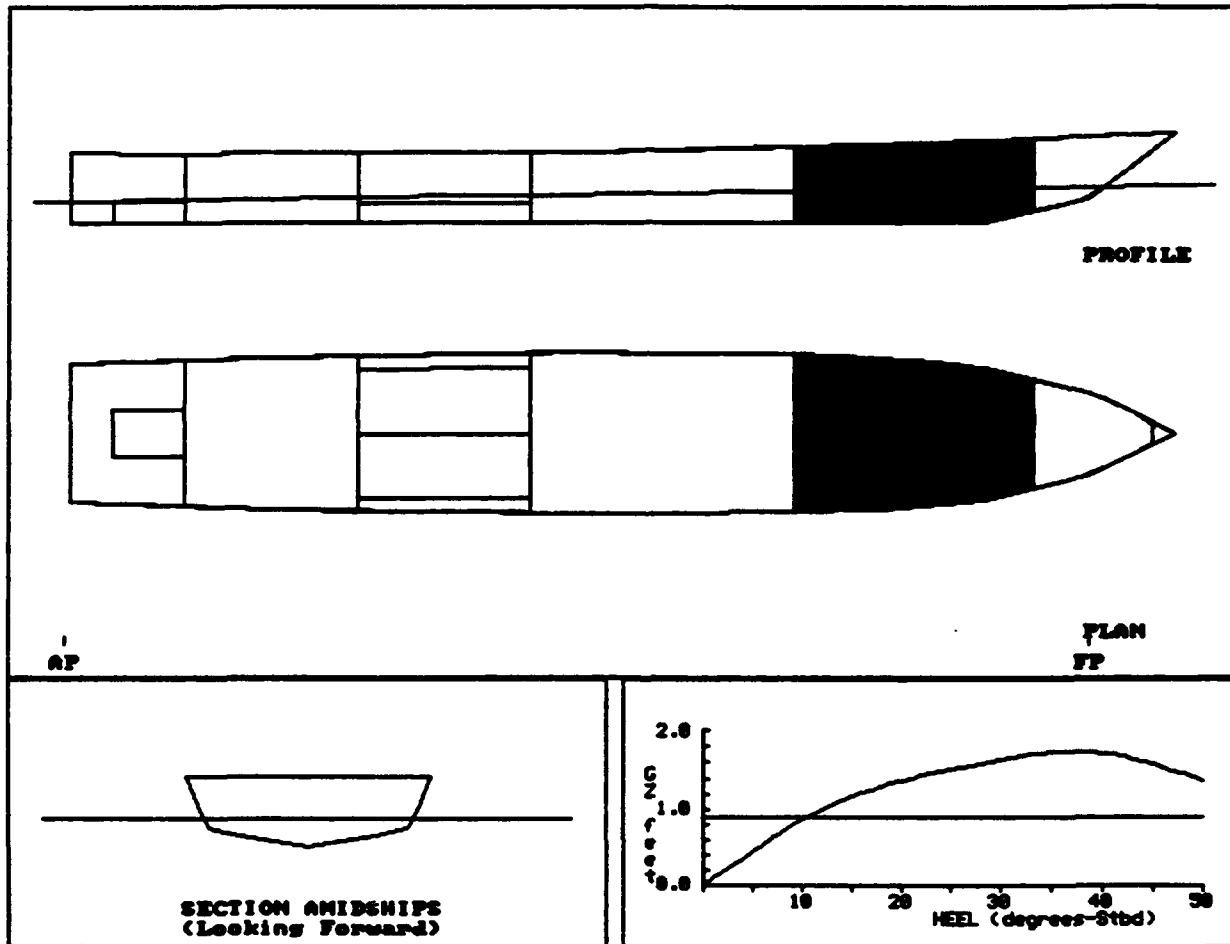

DPRT002A:
 91' CREW BOAT B

COMPARTMENT FLOODING SUMMARY

At 0.0o Heel	PERM.	FLOODED WTR LTons	% FULL (Damaged)	% FULL (Intact)	SP.VOL. ft3/LT	OUTFLOW LTons
CREW	0.95	17.1	FREE	0.0	----	----
Totals		17.1				

INTACT DATA

Draft at AP = 3.620 ft	KMt = 13.123 ft	LCG = 54.766A ft-FP
Draft at FP = 3.000 ft	VCG = 7.880 ft	LCB = 54.805A ft-FP
Displacement = 82.1 LTons	Gmt = 5.243 ft	TCG = 0.000 ft-CL

DRAFT/GZ DATA

HEEL degrees	RIGHTING ARM ft	DRAFT AFT ft	DRAFT FWD ft	FLOODED WATER LTons
0.00	0.000	2.961	4.769	17.1
5.00S	0.440	2.954	4.750	17.1
7.00S	0.619	2.943	4.737	17.1
10.00S	0.858	2.910	4.698	17.1
20.00S	1.365	2.571	4.444	17.0
30.00S	1.640	1.915	3.888	16.5
40.00S	1.718	0.819	3.102	16.6
50.00S	1.368	-0.768	2.211	17.6

Note: Drafts are measured at A.P. and F.P along ship's centerline

IS SUMMARY (Evaluated per IMO (SOLAS'90) Rules for Passenger Ships)
 Available Required

Static Heel Angle	0.00 deg	7.00 deg
Angle at Maximum GZ	38.00S deg	
Maximum GZ	1.738 ft	0.900 ft
Range of Positive GZ	50.00 deg	15.00 deg
Gmt (upright damaged)	4.995 ft	
Righting Area (0.00-7.00)	18.589 ft-deg	2.820 ft-deg

DPR003A:
 91' CREW BOAT B

Imaged Compartments:
 PASSENGERS

	DISPLACEMENT LTons	DRAFT AFT ft	DRAFT FWD ft	TRIM ft	HEEL deg.	UPRIGHT GMT ft
INTACT	82.1	3.620	3.000	0.620A	0.00	5.243
DAMAGED	86.7	3.628	3.257	0.371A	0.00	1.884

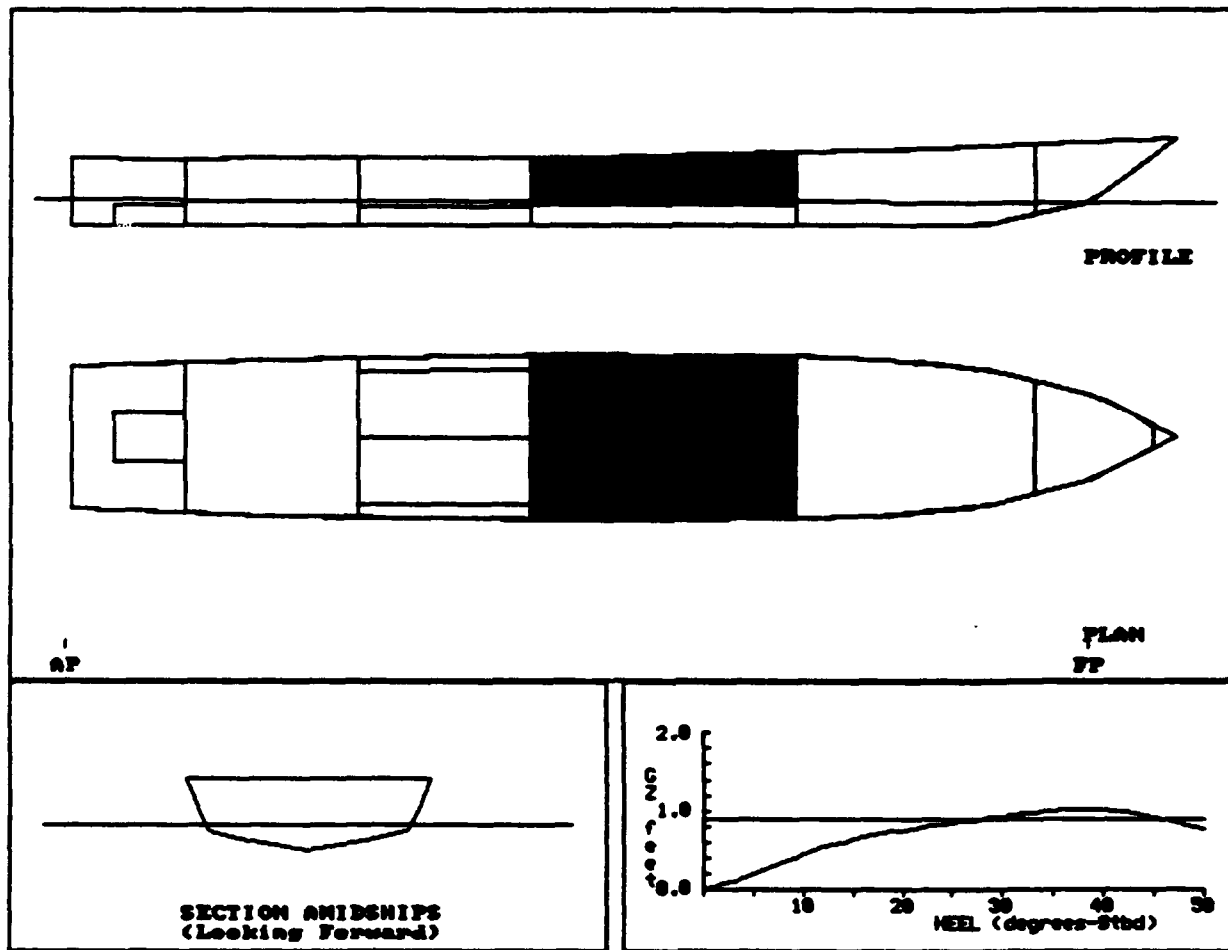

DPRT003A:
 91' CREW BOAT B

COMPARTMENT FLOODING SUMMARY

At 0.0o Heel	PERM.	FLOODED WTR LTons	% FULL (Damaged)	% FULL (Intact)	SP.VOL. ft3/LT	OUTFLOW LTons
PASSENGERS	0.95	4.6	FREE	0.0	----	----
Totals		4.6				

INTACT DATA

Draft at AP = 3.620 ft	Kmt = 13.123 ft	LCG = 54.766A ft-FP
Draft at FP = 3.000 ft	VCG = 7.880 ft	LCB = 54.805A ft-FP
Displacement = 82.1 LTons	Gmt = 5.243 ft	TCG = 0.000 ft-CL

DRAFT/GZ DATA

HEEL degrees	RIGHTING ARM ft	DRAFT AFT ft	DRAFT FWD ft	FLOODED WATER LTons
0.00	0.000	3.628	3.257	4.6
5.00S	0.197	3.628	3.257	5.2
7.00S	0.305	3.611	3.290	6.1
10.00S	0.453	3.592	3.301	7.4
20.00S	0.753	3.315	3.254	12.0
30.00S	0.922	2.708	2.988	16.5
40.00S	1.008	1.757	2.417	20.7
50.00S	0.765	0.627	1.335	23.1

Note: Drafts are measured at A.P. and F.P along ship's centerline

GZ SUMMARY (Evaluated per IMO (SOLAS'90) Rules for Passenger Ships)
 Available Required

Static Heel Angle	0.00 deg	7.00 deg
Angle at Maximum GZ	39.00S deg	
Maximum GZ	1.016 ft	0.900 ft
Range of Positive GZ	50.00 deg	15.00 deg
Gmt (upright damaged)	1.884 ft	
Righting Area (0.00-7.00)	9.876 ft-deg	2.820 ft-deg

DPRT004A:
 91' CREW BOAT B

Imaged Compartments:
 AUX ER

	DISPLACEMENT LTons	DRAFT AFT ft	DRAFT FWD ft	TRIM ft	HEEL deg.	UPRIGHT GNT ft
INTACT	82.1	3.620	3.000	0.620A	0.00	5.243
DAMAGED	86.9	3.809	3.038	0.771A	0.00	3.185

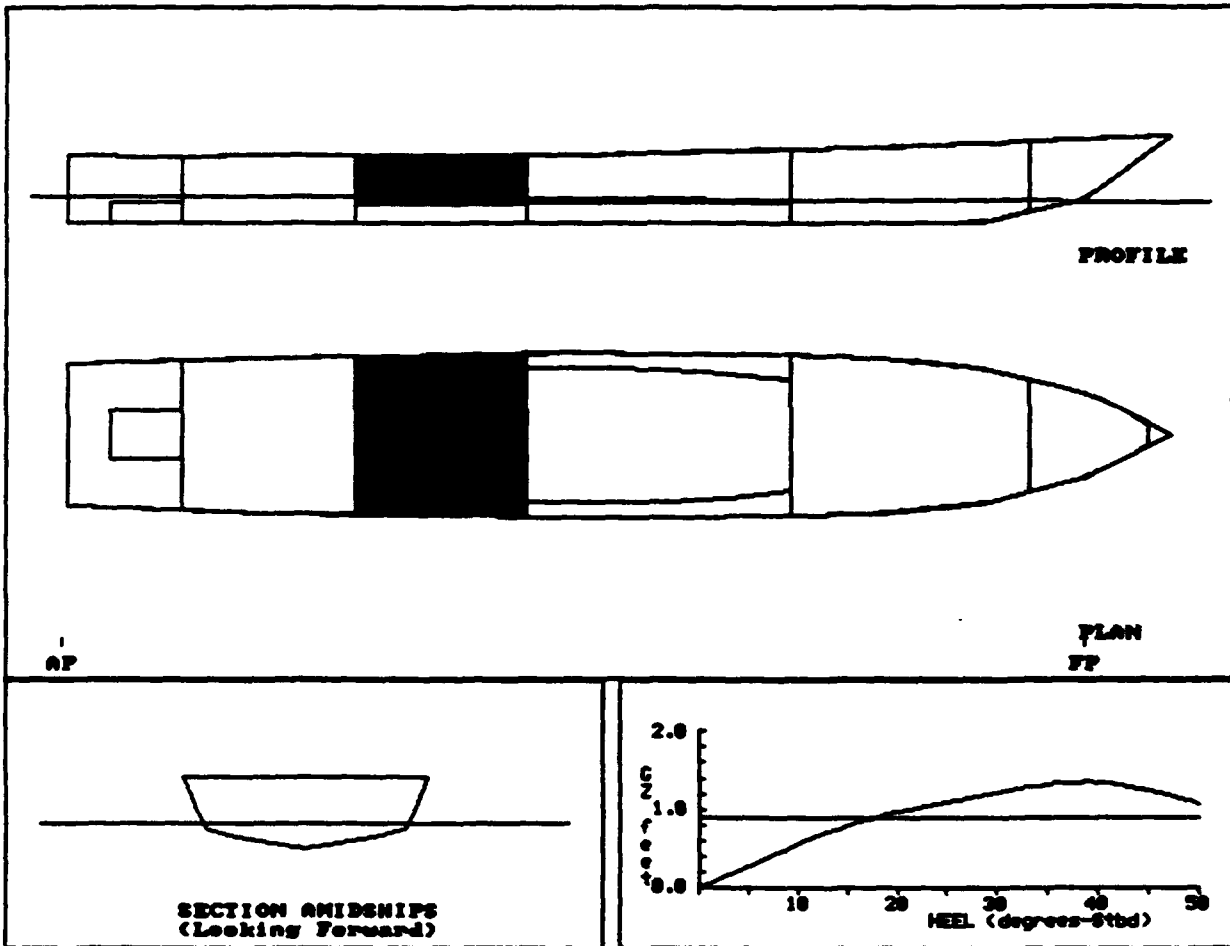

DPRT004A:
 91' CREW BOAT B

COMPARTMENT FLOODING SUMMARY

At 0.0o Heel	PERM.	FLOODED WTR LTons	% FULL (Damaged)	% FULL (Intact)	SP.VOL. ft3/LT	OUTFLOW LTons
AUX ER	0.85	4.8	FREE	0.0	----	----
Totals		4.8				

INTACT DATA

Draft at AP = 3.620 ft	KMt = 13.123 ft	LCG = 54.766A ft-FP
Draft at FP = 3.000 ft	VCG = 7.880 ft	LCB = 54.805A ft-FP
Displacement = 82.1 LTons	GMT = 5.243 ft	TCG = 0.000 ft-CL

DRAFT/GZ DATA

HEEL degrees	RIGHTING ARM ft	DRAFT AFT ft	DRAFT FWD ft	FLOODED WATER LTons
0.00	0.000	3.809	3.038	4.8
5.00S	0.270	3.810	2.999	4.8
7.00S	0.389	3.808	2.975	5.0
10.00S	0.563	3.798	2.924	5.6
20.00S	0.961	3.630	2.579	7.7
30.00S	1.206	3.139	1.994	9.8
40.00S	1.346	2.348	0.989	11.6
50.00S	1.076	1.470	-0.693	12.9

Note: Drafts are measured at A.P. and F.P along ship's centerline

GZ SUMMARY (Evaluated per IMO (SOLAS'90) Rules for Passenger Ships)

	Available	Required
Static Heel Angle	0.00 deg	7.00 deg
Angle at Maximum GZ	40.00S deg	
Maximum GZ	1.351 ft	0.900 ft
Range of Positive GZ	50.00 deg	15.00 deg
Gmt (upright damaged)	3.185 ft	
Righting Area (0.00-7.00)	12.562 ft-deg	2.820 ft-deg

DPRT005A:
 91' CREW BOAT B

Imaged Compartments:
 FO TANK STBD

	DISPLACEMENT LTons	DRAFT AFT ft	DRAFT FWD ft	TRIM ft	HEEL deg.	UPRIGHT GMT ft
INTACT	82.1	3.620	3.000	0.620A	0.00	5.243
DAMAGED	82.1	3.620	3.000	0.620A	0.00	5.608

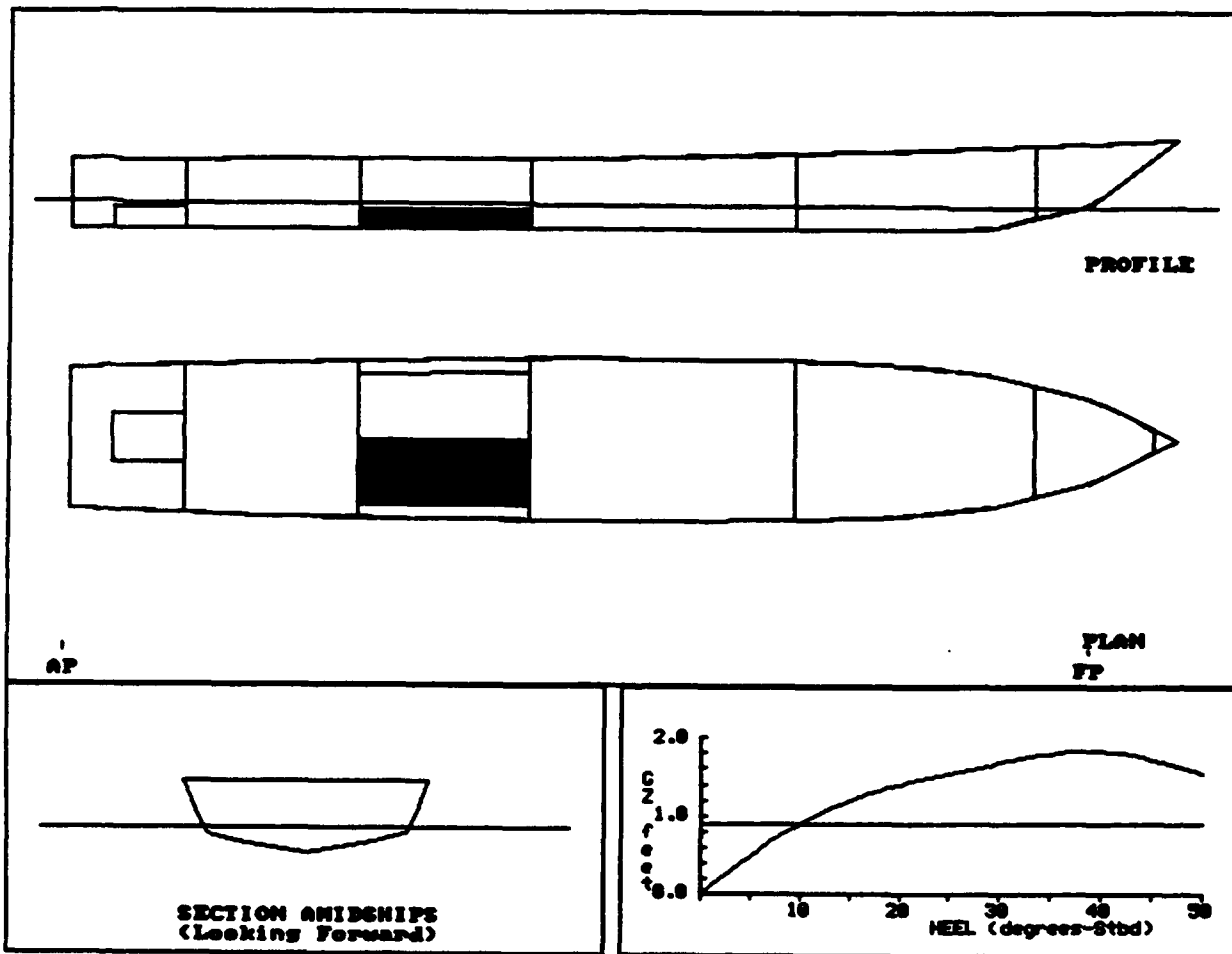

DPRT005A:
 91' CREW BOAT B

COMPARTMENT FLOODING SUMMARY

At 0.0o Heel	PERM.	FLOODED WTR LTons	% FULL (Damaged)	% FULL (Intact)	SP.VOL. ft3/LT	OUTFLOW LTons
FO TANK STBD	0.95	6.2	FREE	100.0	35.0063	6.2
Totals		6.2				6.2

INTACT DATA

Draft at AP = 3.620 ft	Kmt = 13.123 ft	LCG = 54.766A ft-FP
Draft at FP = 3.000 ft	VCG = 7.880 ft	LCB = 54.805A ft-FP
Displacement = 82.1 LTons	GMT = 5.243 ft	TCG = 0.000 ft-CL

DRAFT/GZ DATA

HEEL degrees	RIGHTING ARM ft	DRAFT AFT ft	DRAFT FWD ft	FLOODED WATER LTons
0.00	0.000	3.620	3.000	6.2
5.00S	0.480	3.614	2.968	6.2
7.00S	0.657	3.606	2.934	6.2
10.00S	0.891	3.579	2.864	6.2
20.00S	1.395	3.289	2.491	6.2
30.00S	1.673	2.650	1.877	6.1
40.00S	1.832	1.598	0.815	5.6
50.00S	1.538	0.213	-0.924	4.6

Note: Drafts are measured at A.P. and F.P along ship's centerline

GZ SUMMARY (Evaluated per IMO (SOLAS'90) Rules for Passenger Ships)

	Available	Required
Static Heel Angle	0.00 deg	7.00 deg
Angle at Maximum GZ	40.00S deg	
Maximum GZ	1.837 ft	0.900 ft
Range of Positive GZ	50.00 deg	15.00 deg
Gmt (upright damaged)	5.608 ft	
Righting Area (0.00-7.00)	19.267 ft-deg	2.820 ft-deg

DPR006A:
 91' CREW BOAT B

Damaged Compartments:

AUX ER FO TANK STBD

	DISPLACEMENT LTons	DRAFT AFT ft	DRAFT FWD ft	TRIM ft	HEEL deg.	UPRIGHT GMT ft
INTACT	82.1	3.620	3.000	0.620A	0.00	5.243
DAMAGED	86.9	3.809	3.038	0.771A	0.00	3.445

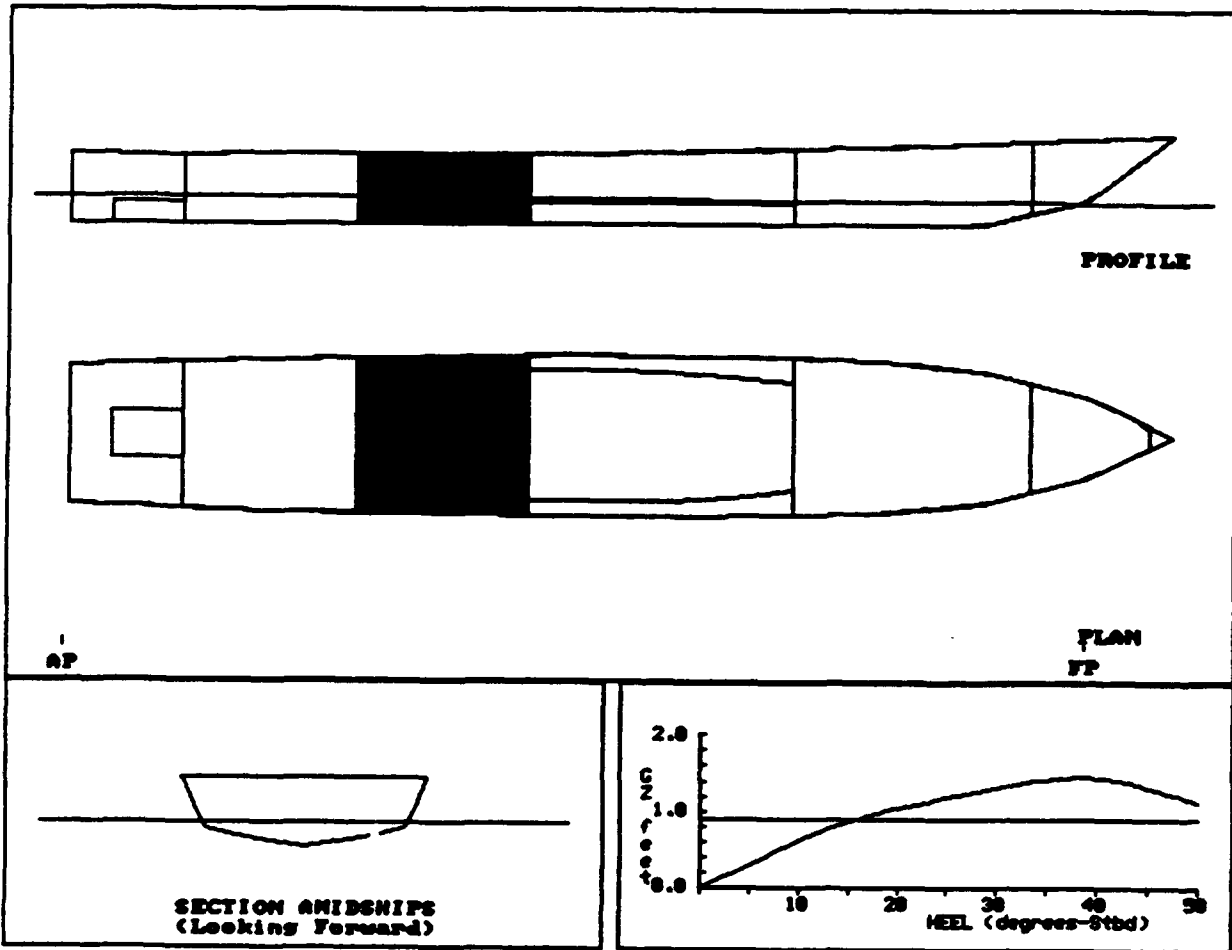

DPRT006A:
 91' CREW BOAT B

COMPARTMENT FLOODING SUMMARY

At 0.0o Heel	PERM.	FLOODED WTR LTons	% FULL (Damaged)	% FULL (Intact)	SP.VOL. ft3/LT	OUTFLOW LTons
AUX ER	0.85	4.8	FREE	0.0	----	----
FO TANK STBD	0.95	6.2	FREE	100.0	35.0063	6.2
Totals		11.0				6.2

INTACT DATA

Draft at AP = 3.620 ft	KMT = 13.123 ft	LCG = 54.766A ft-FP
Draft at FP = 3.000 ft	VCG = 7.880 ft	LCB = 54.805A ft-FP
Displacement = 82.1 LTons	GMT = 5.243 ft	TCG = 0.000 ft-CL

DRAFT/GZ DATA

HEEL degrees	RIGHTING ARM ft	DRAFT AFT ft	DRAFT FWD ft	FLOODED WATER LTons
0.00	0.000	3.809	3.038	11.0
5.00S	0.292	3.810	2.999	11.0
7.00S	0.420	3.808	2.975	11.2
10.00S	0.608	3.798	2.924	11.8
20.00S	1.039	3.630	2.579	13.9
30.00S	1.305	3.139	1.993	16.0
40.00S	1.445	2.331	0.985	17.6
50.00S	1.123	1.386	-0.708	18.1

Note: Drafts are measured at A.P. and F.P along ship's centerline

GZ SUMMARY (Evaluated per IMO (SOLAS'90) Rules for Passenger Ships)

	Available	Required
Static Heel Angle	0.00 deg	7.00 deg
Angle at Maximum GZ	40.00S deg	
Maximum GZ	1.452 ft	0.900 ft
Range of Positive GZ	50.00 deg	15.00 deg
Gmt (upright damaged)	3.445 ft	
Righting Area (0.00-7.00)	13.588 ft-deg	2.820 ft-deg

DPRT007A:
91' CREW BOAT B

Used Compartments:
ENGINE ROOM

	DISPLACEMENT LTONS	DRAFT AFT ft	DRAFT FWD ft	TRIM ft	HEEL deg.	UPRIGHT GMT ft
INTACT	82.1	3.620	3.000	0.620A	0.00	5.243
DAMAGED	104.8	5.152	2.328	2.824A	0.00	4.049

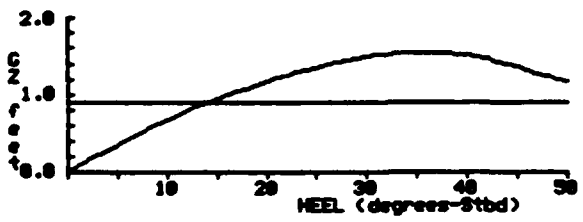
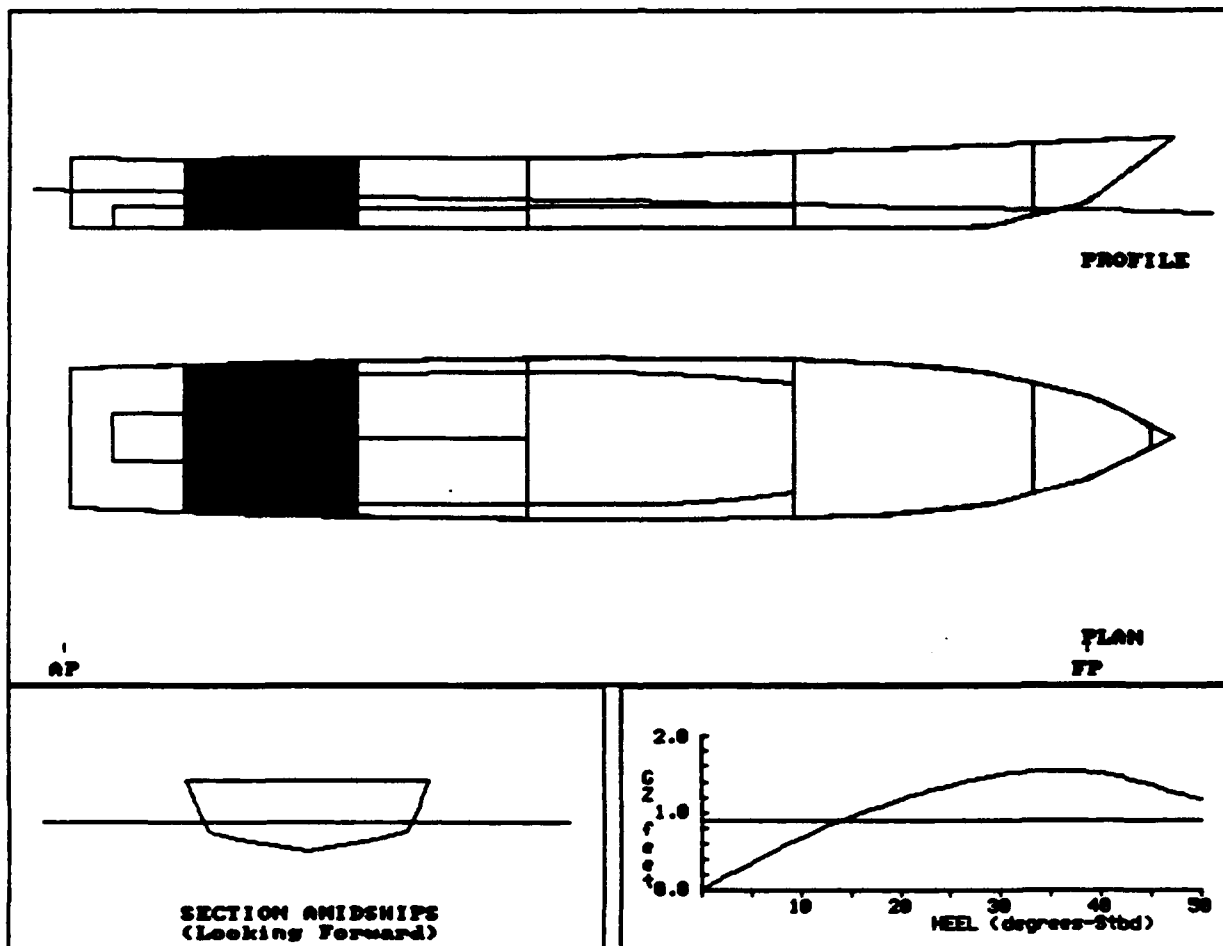

DPRT007A:
 91' CREW BOAT B

COMPARTMENT FLOODING SUMMARY

At 0.0o Heel	PERM.	FLOODED WTR LTons	% FULL (Damaged)	% FULL (Intact)	SP.VOL. ft3/LT	OUTFLOW LTons
ENGINE ROOM	0.85	22.7	FREE	0.0	----	----
Totals		22.7				

INTACT DATA

Draft at AP = 3.620 ft	Kmt = 13.123 ft	LCG = 54.766A ft-FP
Draft at FP = 3.000 ft	VCG = 7.880 ft	LCB = 54.805A ft-FP
Displacement = 82.1 LTons	GMT = 5.243 ft	TCG = 0.000 ft-CL

DRAFT/GZ DATA

HEEL degrees	RIGHTING ARM ft	DRAFT AFT ft	DRAFT FWD ft	FLOODED WATER LTons
0.00	0.000	5.152	2.328	22.7
5.00S	0.346	5.145	2.298	22.7
7.00S	0.480	5.141	2.266	22.7
10.00S	0.668	5.128	2.196	22.7
20.00S	1.162	4.994	1.756	22.5
30.00S	1.486	4.571	1.037	22.3
40.00S	1.503	4.169	-0.331	22.2
50.00S	1.155	3.845	-2.472	22.1

Note: Drafts are measured at A.P. and F.P along ship's centerline

GZ SUMMARY (Evaluated per IMO (SOLAS'90) Rules for Passenger Ships)

	Available	Required
Static Heel Angle	0.00 deg	7.00 deg
Angle at Maximum GZ	37.00S deg	
Maximum GZ	1.545 ft	0.900 ft
Range of Positive GZ	50.00 deg	15.00 deg
Gmt (upright damaged)	4.049 ft	
Righting Area (0.00-%.00)	15.132 ft-deg	2.820 ft-deg

DPR008A:
 91' CREW BOAT B

Imaged Compartments:
 LAZARETTE

	DISPLACEMENT LTons	DRAFT AFT ft	DRAFT FWD ft	TRIM ft	HEEL deg.	UPRIGHT GNT ft
INTACT	82.1	3.620	3.000	0.620A	0.00	5.243
DAMAGED	95.0	4.831	2.172	2.658A	0.00	4.236

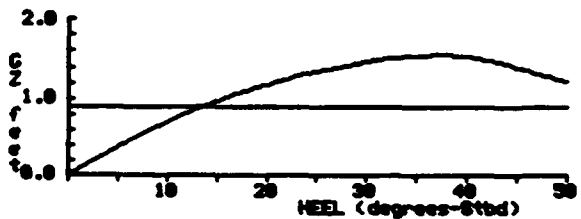
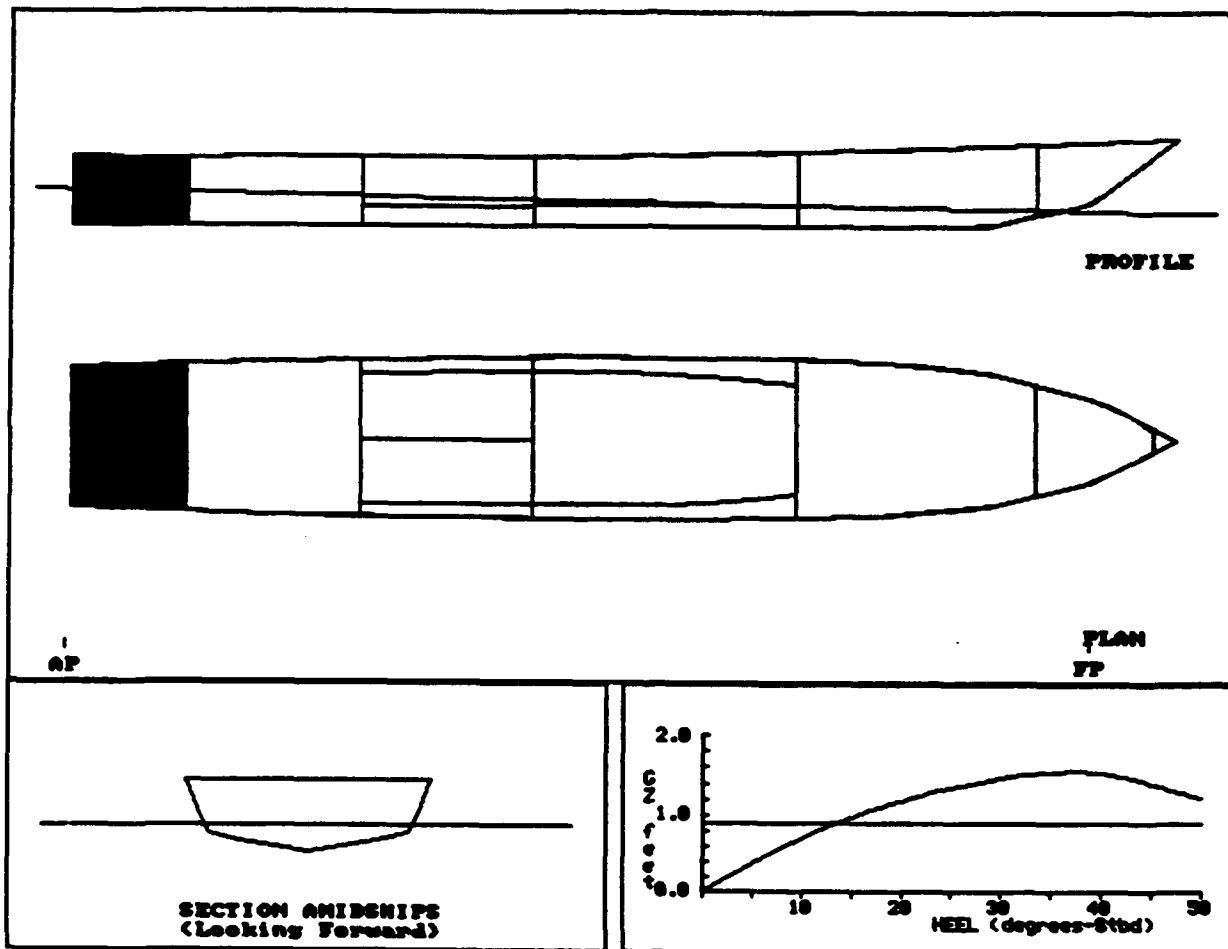

DPRT008A:
 91' CREW BOAT B

COMPARTMENT FLOODING SUMMARY

At 0.0o Heel	PERM.	FLOODED WTR LTons	% FULL (Damaged)	% FULL (Intact)	SP.VOL. ft3/LT	OUTFLOW LTons
LAZARETTE	0.90	12.9	FREE	0.0	----	----
Totals		12.9				

INTACT DATA

Draft at AP = 3.620 ft	Kmt = 13.123 ft	LCG = 54.766A ft-FP
Draft at FP = 3.000 ft	VCG = 7.880 ft	LCB = 54.805A ft-FP
Displacement = 82.1 LTons	Gmt = 5.243 ft	TCG = 0.000 ft-CL

DRAFT/GZ DATA

HEEL degrees	RIGHTING ARM ft	DRAFT AFT ft	DRAFT FWD ft	FLOODED WATER LTons
0.00	0.000	4.831	2.172	12.9
5.00S	0.367	4.831	2.128	12.9
7.00S	0.507	4.829	2.091	12.9
10.00S	0.703	4.820	2.010	13.0
20.00S	1.175	4.640	1.565	12.7
30.00S	1.460	4.136	0.854	12.3
40.00S	1.530	3.606	-0.520	12.6
50.00S	1.204	3.216	-2.835	13.2

Note: Drafts are measured at A.P. and F.P along ship's centerline

GZ SUMMARY (Evaluated per IMO (SOLAS'90) Rules for Passenger Ships)

	Available	Required
Static Heel Angle	0.00 deg	7.00 deg
Angle at Maximum GZ	38.00S deg	
Maximum GZ	1.551 ft	0.900 ft
Range of Positive GZ	50.00 deg	15.00 deg
Gmt (upright damaged)	4.236 ft	
Righting Area (0.00-%.00)	15.632 ft-deg	2.820 ft-deg

DPRT009A:
 91' CREW BOAT B

amaged Compartments:

LAZARETTE POT H2O TANK

	DISPLACEMENT LTons	DRAFT AFT ft	DRAFT FWD ft	TRIM ft	HEEL deg.	UPRIGHT Gmt ft
INTACT	82.1	3.620	3.000	0.620A	0.00	5.243
DAMAGED	94.9	4.820	2.179	2.641A	0.00	4.395

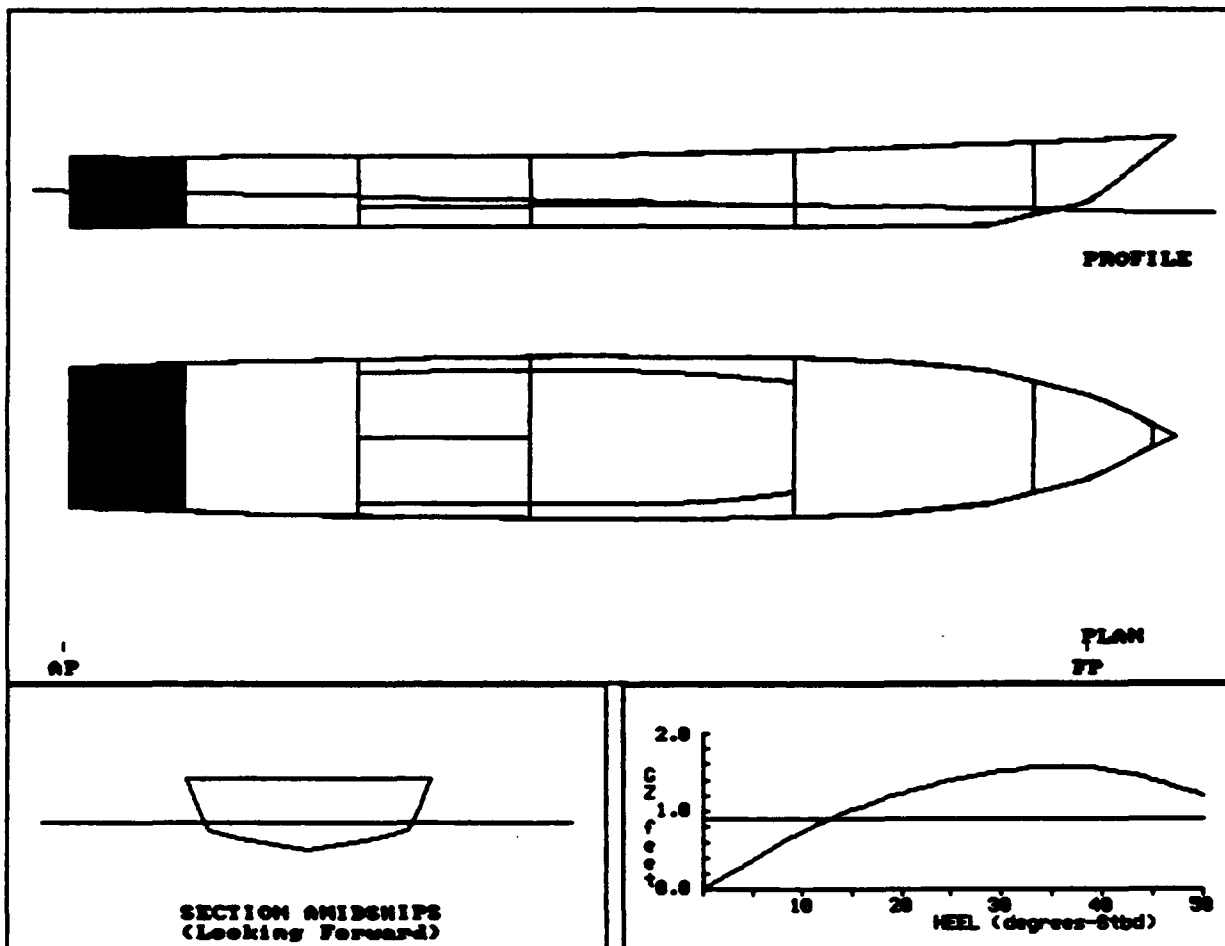

DPRT009A:
 91' CREW BOAT B

COMPARTMENT FLOODING SUMMARY

At 0.0o Heel	PERM.	FLOODED WTR LTons	% FULL (Damaged)	% FULL (Intact)	SP.VOL. ft3/LT	OUTFLOW LTons
LAZARETTE	0.90	12.8	FREE	0.0	----	----
POT H2O TANK	0.95	2.9	FREE	100.0	34.1500	3.0
Totals		15.8				3.0

INTACT DATA

Draft at AP = 3.620 ft Kmt = 13.123 ft LCG = 54.766A ft-FP
 Draft at FP = 3.000 ft VCG = 7.880 ft LCB = 54.805A ft-FP
 Displacement = 82.1 LTons GMT = 5.243 ft TCG = 0.000 ft-CL

DRAFT/GZ DATA

HEEL degrees	RIGHTING ARM ft	DRAFT AFT ft	DRAFT FWD ft	FLOODED WATER LTons
0.00	0.000	4.820	2.179	15.8
5.00S	0.381	4.821	2.136	15.8
7.00S	0.526	4.818	2.098	15.9
10.00S	0.729	4.809	2.017	15.9
20.00S	1.217	4.628	1.574	15.6
30.00S	1.500	4.100	0.878	15.0
40.00S	1.543	3.439	-0.408	14.5
50.00S	1.191	2.831	-2.570	14.5

Note: Drafts are measured at A.P. and F.P along ship's centerline

GZ SUMMARY (Evaluated per IMO (SOLAS'90) Rules for Passenger Ships)
 Available Required

Static Heel Angle	0.00 deg	7.00 deg
Angle at Maximum GZ	37.00S deg	
Maximum GZ	1.573 ft	0.900 ft
Range of Positive GZ	50.00 deg	15.00 deg
Gmt (upright damaged)	4.395 ft	
Righting Area (0.00-3.00)	16.205 ft-deg	2.820 ft-deg

DPR010A:
 91' CREW BOAT B

Imaged Compartments:
 POT N2O TANK

	DISPLACEMENT LTons	DRAFT AFT ft	DRAFT FWD ft	TRIM ft	HEEL deg.	UPRIGHT GMT ft
INTACT	82.1	3.620	3.000	0.620A	0.00	5.243
DAMAGED	82.0	3.615	3.002	0.612A	0.00	5.378

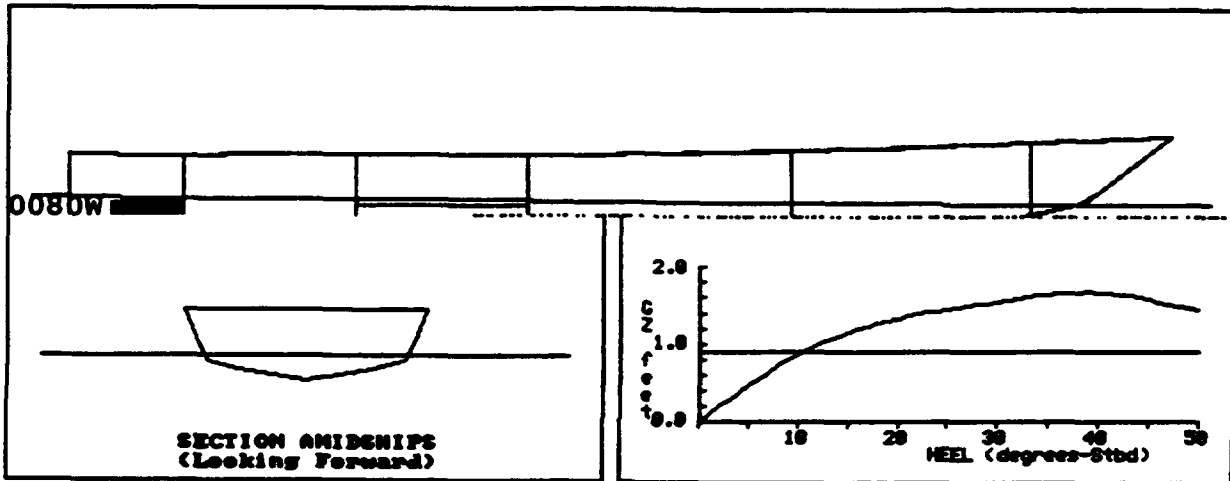

DPRT010A:
 91' CREW BOAT B

COMPARTMENT FLOODING SUMMARY

At 0.0o Heel	PERM.	FLOODED WTR LTons	% FULL (Damaged)	% FULL (Intact)	SP.VOL. ft3/LT	OUTFLOW LTons
POT H2O TANK	0.95	2.9	FREE	100.0	34.1500	3.0
Totals		2.9				3.0

INTACT DATA

Draft at AP = 3.620 ft	KMt = 13.123 ft	LCG = 54.766A ft-FP
Draft at FP = 3.000 ft	VCG = 7.880 ft	LCB = 54.805A ft-FP
Displacement = 82.1 LTons	Gmt = 5.243 ft	TCG = 0.000 ft-CL

DRAFT/GZ DATA

HEEL degrees	RIGHTING ARM ft	DRAFT AFT ft	DRAFT FWD ft	FLOODED WATER LTons
0.00	0.000	3.615	3.002	2.9
5.00S	0.460	3.607	2.972	2.9
7.00S	0.630	3.600	2.939	2.9
10.00S	0.854	3.573	2.868	2.9
20.00S	1.322	3.258	2.510	2.7
30.00S	1.544	2.547	1.943	2.1
40.00S	1.671	1.374	1.004	1.3
50.00S	1.426	-0.113	-0.601	0.8

Note: Drafts are measured at A.P. and F.P along ship's centerline

GZ SUMMARY (Evaluated per IMO (SOLAS'90) Rules for Passenger Ships)

	Available	Required
Static Heel Angle	0.00 deg	7.00 deg
Angle at Maximum GZ	40.00S deg	
Maximum GZ	1.675 ft	0.900 ft
Range of Positive GZ	50.00 deg	15.00 deg
Gmt (upright damaged)	5.378 ft	
Righting Area (0.00-7.00)	18.386 ft-deg	2.820 ft-deg

DAMAGE STABILITY SUMMARY
91' CREW BOAT B

No.	FILE NAME	DAMAGED COMP. LISTING	---Intact Condition---			-----Equilibrium Condition After Damage-----					
			MN.DRAFT (ft)	VCG (ft)	GMt (ft)	HEEL (deg)	MAX.GZ (ft)	RANGE (deg)	AREA (ft-deg)	DAM.GMT (ft)	SURVIVAL
1	RTRN001B	1	3.050	8.840	5.223	0.0	1.177	50.00	15.30	5.169	Yes
2	RTRN002B	2	3.050	8.840	5.223	0.0	1.236	50.00	16.27	5.088	Yes
3	RTRN003B	3	3.050	8.840	5.223	0.0	0.500	50.00	7.93	1.955	No *F
4	RTRN004B	4	3.050	8.840	5.223	0.0	0.845	50.00	10.48	2.796	No *F
5	RTRN005B	5	3.050	8.840	5.223	2.8S	1.347	47.19	12.60	----	Yes
6	RTRN006B	4,5	3.050	8.840	5.223	4.7S	0.983	45.27	7.38	----	No *F
7	RTRN007B	7	3.050	8.840	5.223	0.0	1.095	50.00	12.71	3.712	Yes
8	RTRN008B	8	3.050	8.840	5.223	0.0	1.091	50.00	13.09	4.034	Yes
9	RTRN009B	8,9	3.050	8.840	5.223	0.0	1.195	50.00	14.26	4.169	Yes

*F WARNING: The required GMt for non-survival cases does not meet all survival criteria.

RTRN001B:
 91' CREW BOAT B

Imaged Compartments:
 FOREPEAK

	DISPLACEMENT LTons	DRAFT AFT ft	DRAFT FWD ft	TRIM ft	HEEL deg.	UPRIGHT GMT ft
INTACT	70.8	3.100	3.000	0.100A	0.00	5.223
DAMAGED	70.8	3.095	3.011	0.084A	0.00	5.169

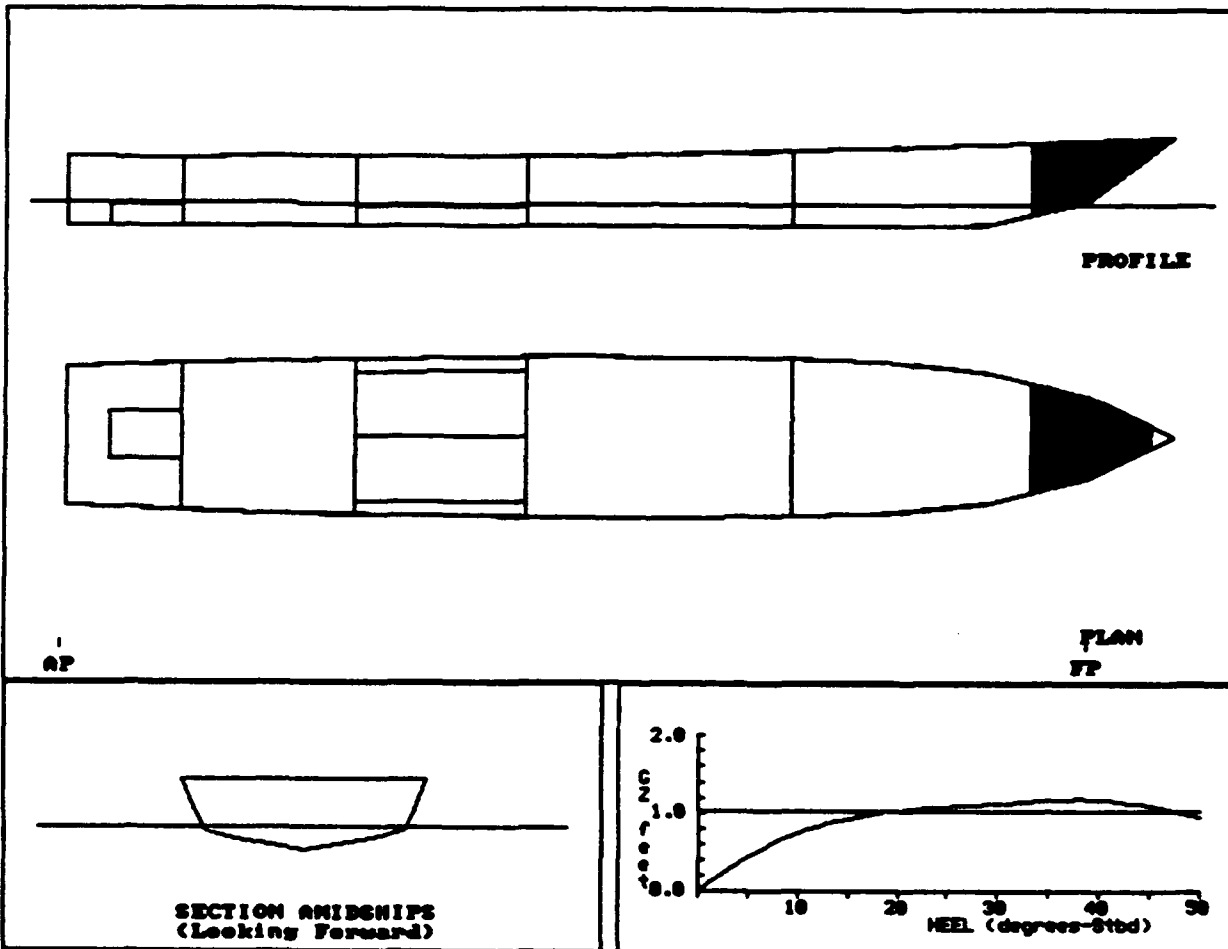

RTRN001B:
 91' CREW BOAT B

COMPARTMENT FLOODING SUMMARY

At 0.0o Heel	PERM.	FLOODED WTR LTons	% FULL (Damaged)	% FULL (Intact)	SP.VOL. ft ³ /LT	OUTFLOW LTons
FOREPEAK	0.95	0.1	FREE	0.0	----	----
Totals		0.1				

INTACT DATA

Draft at AP = 3.100 ft	KMt = 14.063 ft	LCG = 53.702A ft-FP
Draft at FP = 3.000 ft	VCG = 8.840 ft	LCB = 53.710A ft-FP
Displacement = 70.8 LTons	GMT = 5.223 ft	TCG = 0.000 ft-CL

DRAFT/GZ DATA

HEEL degrees	RIGHTING ARM ft	DRAFT AFT ft	DRAFT FWD ft	FLOODED WATER LTons
0.00	0.000	3.095	3.011	0.1
5.00S	0.433	3.089	2.969	0.1
7.00S	0.574	3.075	2.931	0.1
10.00S	0.741	3.028	2.860	0.0
20.00S	1.027	2.660	2.494	0.0
30.00S	1.114	1.945	1.891	0.0
40.00S	1.169	0.792	0.857	0.0
50.00S	0.949	-0.829	-0.841	0.0

Note: Drafts are measured at A.P. and F.P along ship's centerline

GZ SUMMARY (Evaluated per IMO (SOLAS'90) Rules for Passenger Ships)

	Available	Required
Static Heel Angle	0.00 deg	7.00 deg
Angle at Maximum GZ	39.00S deg	
Maximum GZ	1.177 ft	1.020 ft
Range of Positive GZ	50.00 deg	15.00 deg
Gmt (upright damaged)	5.169 ft	
Righting Area (0.00-3.00)	15.298 ft-deg	2.820 ft-deg

RTRN002B:
 91' CREW BOAT B

Used Compartments:
 CREW

	DISPLACEMENT LTons	DRAFT AFT ft	DRAFT FWD ft	TRIM ft	HEEL deg.	UPRIGHT GMT ft
INTACT	70.8	3.100	3.000	0.100A	0.00	5.223
DAMAGED	86.8	2.467	4.687	2.220F	0.00	5.088

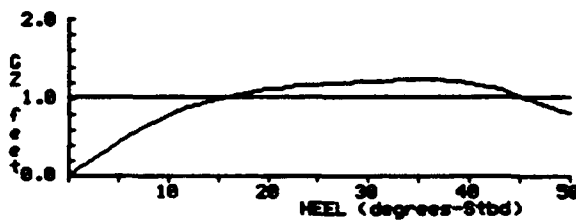
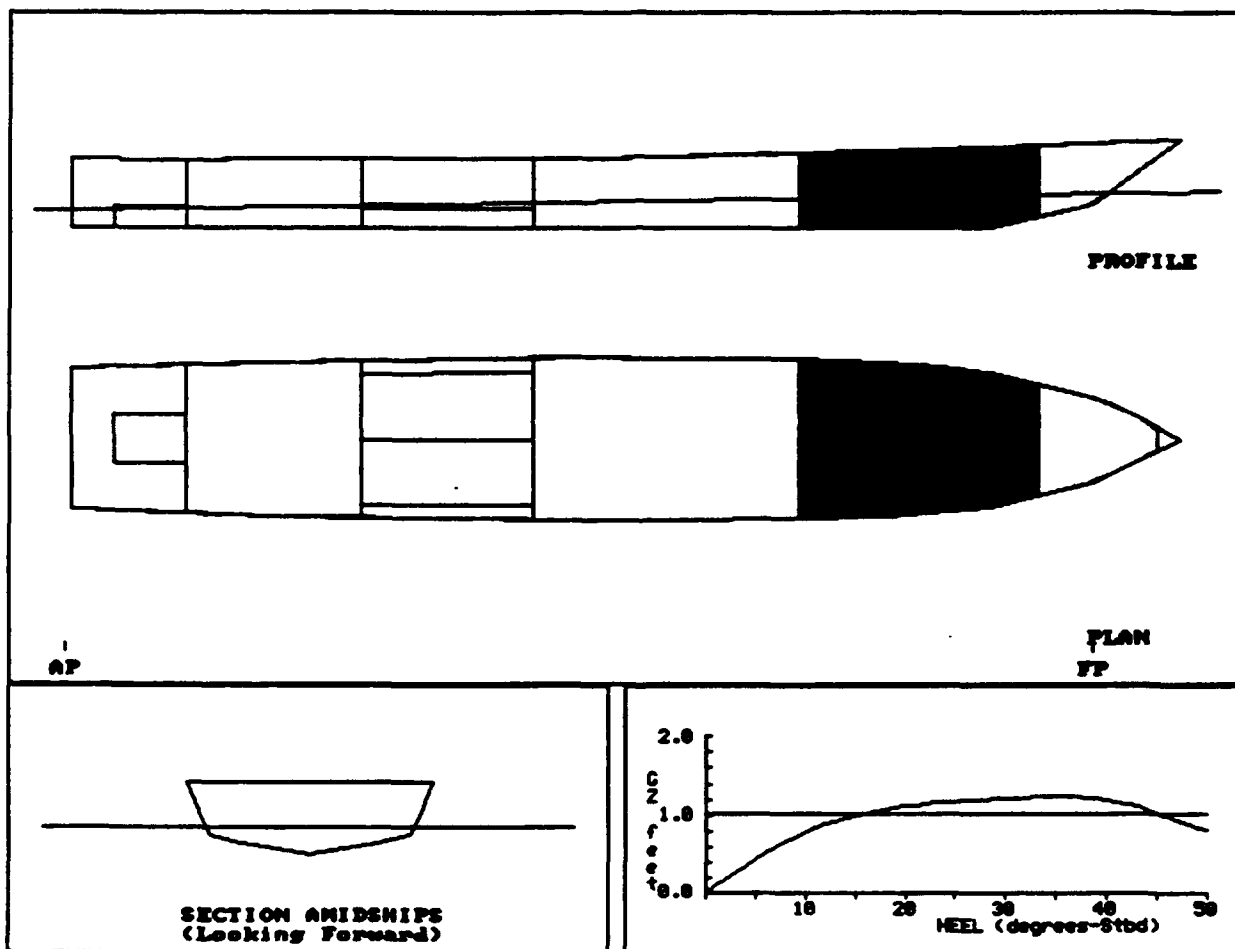

RTRN002B:
 91' CREW BOAT B

COMPARTMENT FLOODING SUMMARY

At 0.0o Heel	PERM.	FLOODED WTR LTons	% FULL (Damaged)	% FULL (Intact)	SP.VOL. ft3/LT	OUTFLOW LTons
CREW	0.95	16.0	FREE	0.0	----	----
Totals		16.0				

INTACT DATA

Draft at AP = 3.100 ft	Kmt = 14.063 ft	LCG = 53.702A ft-FP
Draft at FP = 3.000 ft	VCG = 8.840 ft	LCB = 53.710A ft-FP
Displacement = 70.8 LTons	GMT = 5.223 ft	TCG = 0.000 ft-CL

DRAFT/GZ DATA

HEEL degrees	RIGHTING ARM ft	DRAFT AFT ft	DRAFT FWD ft	FLOODED WATER LTons
0.00	0.000	2.467	4.687	16.0
5.00S	0.443	2.457	4.672	16.0
7.00S	0.599	2.432	4.664	16.1
10.00S	0.783	2.373	4.628	16.1
20.00S	1.111	1.957	4.378	15.9
30.00S	1.209	1.220	3.830	15.4
40.00S	1.193	-0.001	3.015	15.3
50.00S	0.805	-1.881	2.064	16.2

Note: Drafts are measured at A.P. and F.P along ship's centerline

GZ SUMMARY (Evaluated per IMO (SOLAS'90) Rules for Passenger Ships)
 Available Required

Static Heel Angle	0.00 deg	7.00 deg
Angle at Maximum GZ	36.00S deg	
Maximum GZ	1.236 ft	1.020 ft
Range of Positive GZ	50.00 deg	15.00 deg
Gmt (upright damaged)	5.088 ft	
Righting Area (0.00-7.00)	16.268 ft-deg	2.820 ft-deg

RTRN003B:
 91' CREW BOAT B

Imaged Compartments:
 PASSENGERS

	DISPLACEMENT LTons	DRAFT AFT ft	DRAFT FWD ft	TRIM ft	HEEL deg.	UPRIGHT Gmt ft
INTACT	70.8	3.100	3.000	0.100A	0.00	5.223
DAMAGED	71.6	3.092	3.059	0.033A	0.00	1.955

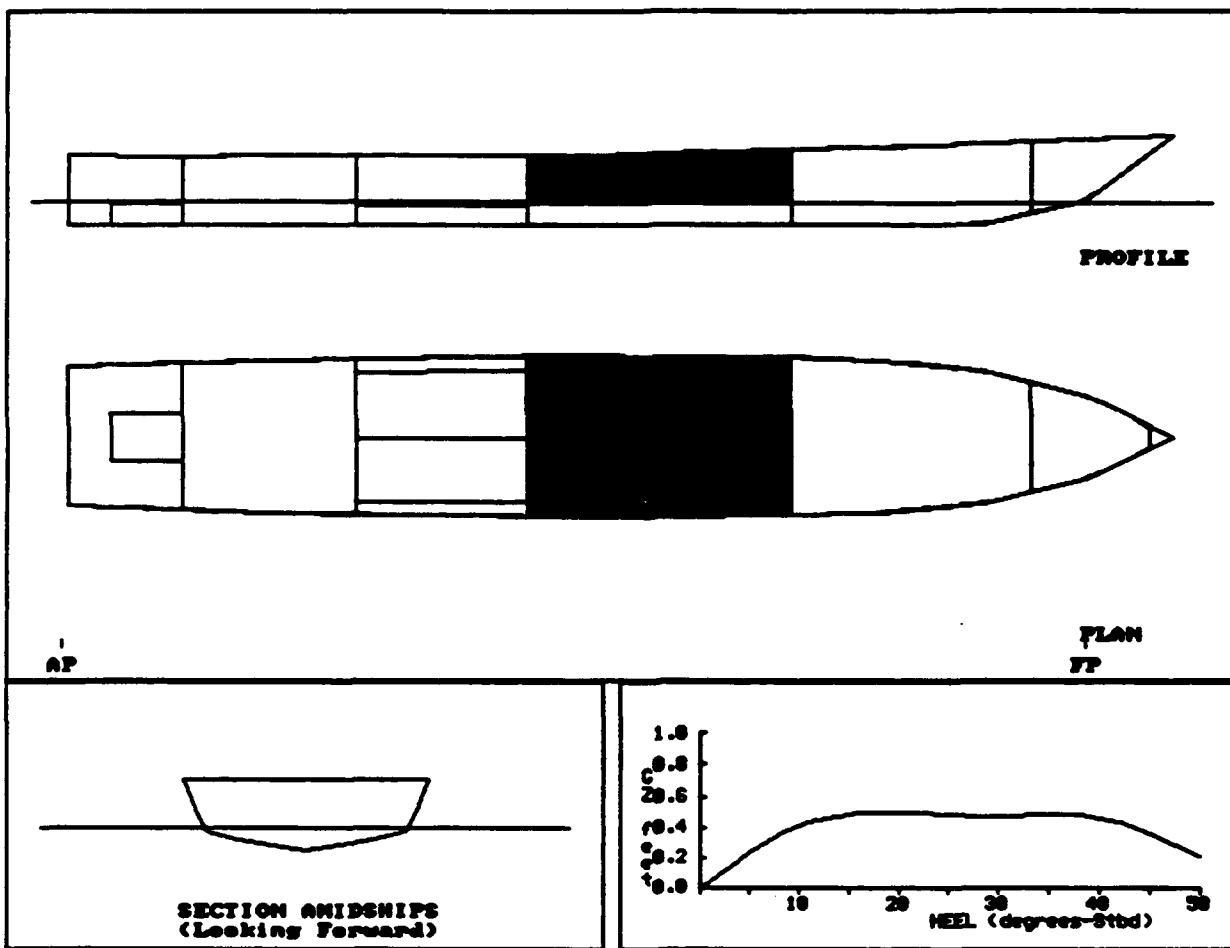

RTRN003B:
 91' CREW BOAT B

COMPARTMENT FLOODING SUMMARY

At 0.0o Heel	PERM.	FLOODED WTR LTons	% FULL (Damaged)	% FULL (Intact)	SP.VOL. ft ³ /LT	OUTFLOW LTons
PASSENGERS	0.95	0.8	FREE	0.0	----	----
Totals		0.8				

INTACT DATA

Draft at AP = 3.100 ft	KMT = 14.063 ft	LCG = 53.702A ft-FP
Draft at FP = 3.000 ft	VCG = 8.840 ft	LCB = 53.710A ft-FP
Displacement = 70.8 LTons	GMT = 5.223 ft	TCG = 0.000 ft-CL

DRAFT/GZ DATA

HEEL degrees	RIGHTING ARM ft	DRAFT AFT ft	DRAFT FWD ft	FLOODED WATER LTons
0.00	0.000	3.092	3.059	0.8
5.00S	0.234	3.096	3.132	2.9
7.00S	0.315	3.081	3.160	3.9
10.00S	0.405	3.047	3.167	5.3
20.00S	0.499	2.687	3.132	9.8
30.00S	0.471	1.995	2.884	14.2
40.00S	0.462	0.880	2.317	18.5
50.00S	0.211	-0.599	1.249	21.1

Note: Drafts are measured at A.P. and F.P along ship's centerline

GZ SUMMARY (Evaluated per IMO (SOLAS'90) Rules for Passenger Ships)

	Available	Required
Static Heel Angle	0.00 deg	7.00 deg
Angle at Maximum GZ	20.00S deg	
*** Maximum GZ	0.500 ft	1.020 ft
Range of Positive GZ	50.00 deg	15.00 deg
Gmt (upright damaged)	1.955 ft	
Righting Area (0.00-7.00)	7.929 ft-deg	2.820 ft-deg

*** indicates failure to meet criterion

RTRN004B:
 91' CREW BOAT B

Imaged Compartments:
 AUX ER

	DISPLACEMENT LTons	DRAFT AFT ft	DRAFT FWD ft	TRIM ft	HEEL deg.	UPRIGHT GMT ft
INTACT	70.8	3.100	3.000	0.100A	0.00	5.223
DAMAGED	72.9	3.184	3.019	0.166A	0.00	2.796

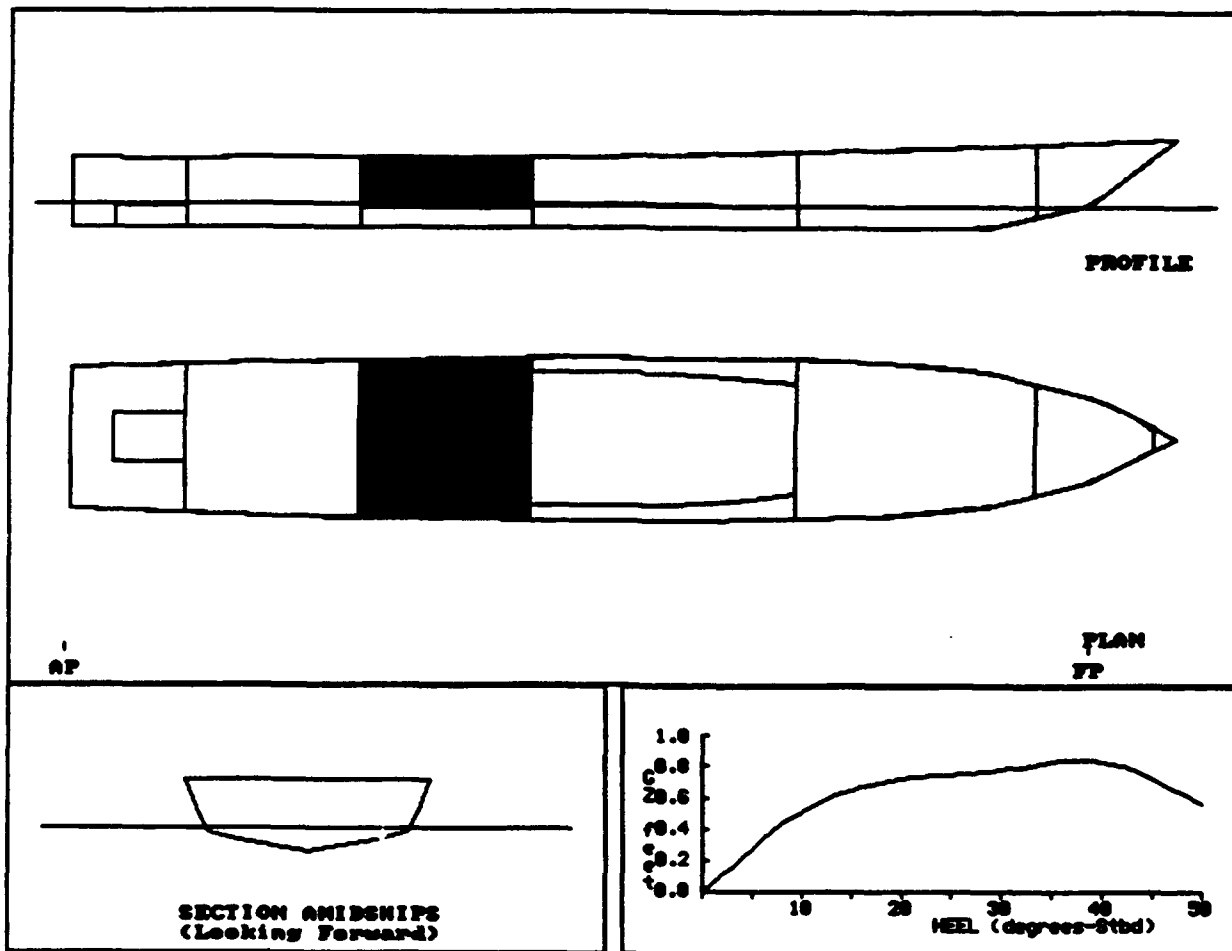

RTRN004B:
 91' CREW BOAT B

COMPARTMENT FLOODING SUMMARY

At 0.0o Heel	PERM.	FLOODED WTR LTons	% FULL (Damaged)	% FULL (Intact)	SP.VOL. ft ³ /LT	OUTFLOW LTons
AUX ER	0.85	2.1	FREE	0.0	----	----
Totals		2.1				

INTACT DATA

Draft at AP = 3.100 ft	KMt = 14.063 ft	LCG = 53.702A ft-FP
Draft at FP = 3.000 ft	VCG = 8.840 ft	LCB = 53.710A ft-FP
Displacement = 70.8 LTons	GMT = 5.223 ft	TCG = 0.000 ft-CL

DRAFT/GZ DATA

HEEL degrees	RIGHTING ARM ft	DRAFT AFT ft	DRAFT FWD ft	FLOODED WATER LTons
0.00	0.000	3.184	3.019	2.1
5.00S	0.273	3.200	2.980	2.6
7.00S	0.381	3.208	2.947	3.1
10.00S	0.510	3.189	2.893	3.8
20.00S	0.717	2.944	2.557	6.0
30.00S	0.778	2.369	1.982	8.0
40.00S	0.835	1.390	1.006	9.9
50.00S	0.561	0.139	-0.650	11.2

Note: Drafts are measured at A.P. and F.P along ship's centerline

GZ SUMMARY (Evaluated per IMO (SOLAS'90) Rules for Passenger Ships)
 Available Required

Static Heel Angle	0.00 deg	7.00 deg
Angle at Maximum GZ	39.00S deg	
*** Maximum GZ	0.845 ft	1.020 ft
Range of Positive GZ	50.00 deg	15.00 deg
Gmt (upright damaged)	2.796 ft	
Righting Area (0.00-7.00)	10.484 ft-deg	2.820 ft-deg

*** indicates failure to meet criterion

RTRN005B:
 91' CREW BOAT B

Imaged Compartments:
 FO TANK STD

	DISPLACEMENT LTons	DRAFT AFT ft	DRAFT FWD ft	TRIM ft	HEEL deg.	UPRIGHT GMT ft
INTACT	70.8	3.100	3.000	0.100A	0.00	5.223
DAMAGED	76.3	3.315	3.036	0.278A	2.81S	5.655

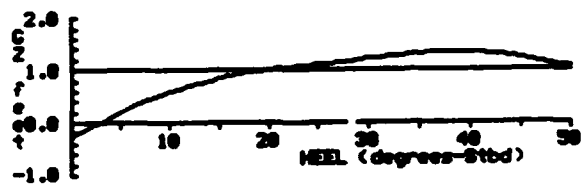
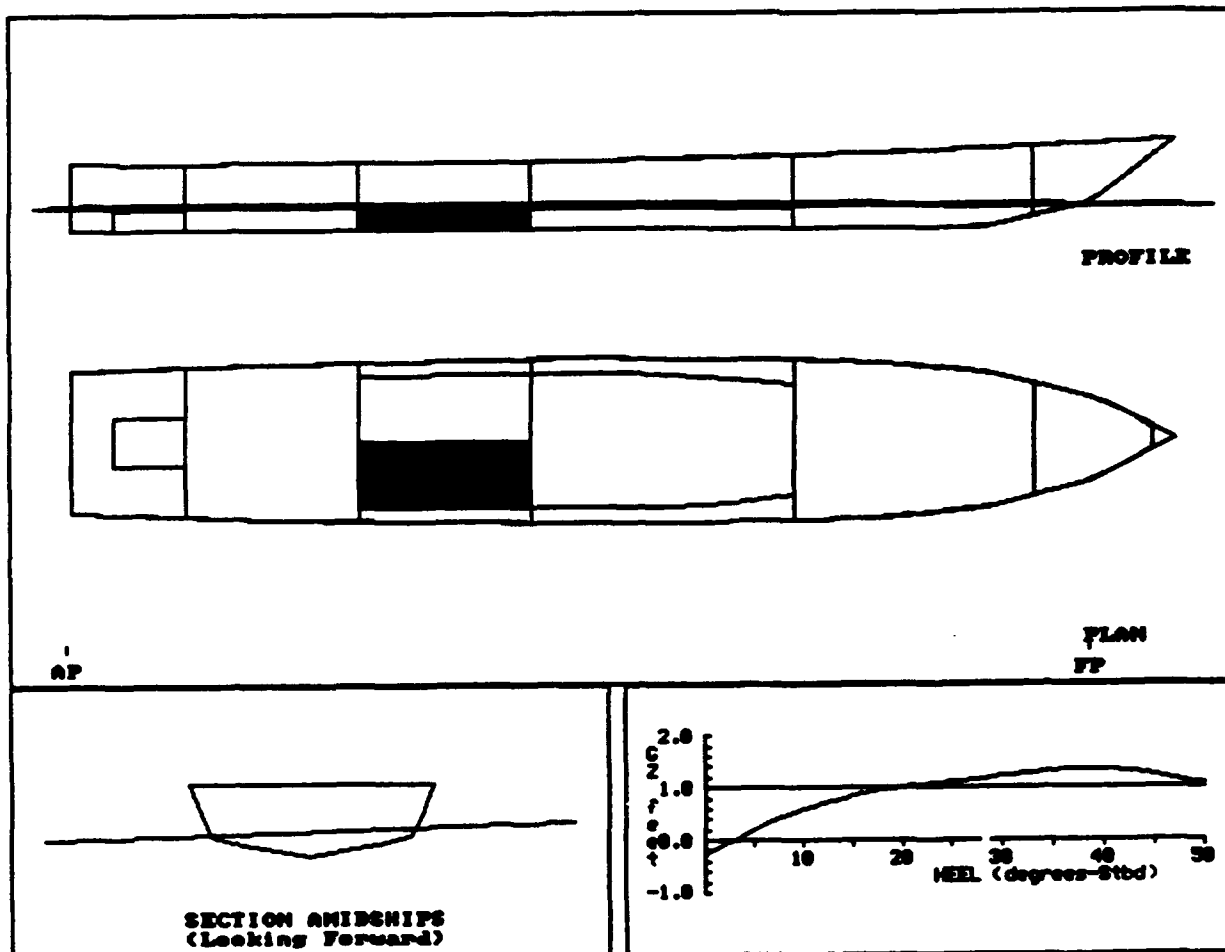

RTRN005B:
 91' CREW BOAT B

COMPARTMENT FLOODING SUMMARY

At 2.8oS Heel	PERM.	FLOODED WTR LTons	‡ FULL (Damaged)	‡ FULL (Intact)	SP.VOL. ft3/LT	OUTFLOW LTons
FO TANK STBD	0.95	6.2	FREE	10.0	35.0063	0.6
Totals		6.2				0.6

INTACT DATA

Draft at AP = 3.100 ft	KMt = 14.063 ft	LCG = 53.702A ft-FP
Draft at FP = 3.000 ft	VCG = 8.840 ft	LCB = 53.710A ft-FP
Displacement = 70.8 LTons	GMt = 5.223 ft	TCG = 0.000 ft-CL

DRAFT/GZ DATA

HEEL degrees	RIGHTING ARM ft	DRAFT AFT ft	DRAFT FWD ft	FLOODED WATER LTons
0.00	-0.277	3.319	3.048	6.2
5.00S	0.205	3.310	3.018	6.2
7.00S	0.374	3.299	2.983	6.2
10.00S	0.586	3.262	2.914	6.2
20.00S	1.009	2.926	2.552	6.2
30.00S	1.212	2.235	1.951	6.0
40.00S	1.343	1.076	0.944	5.4
50.00S	1.063	-0.523	-0.771	4.2

Note: Drafts are measured at A.P. and F.P along ship's centerline

GZ SUMMARY (Evaluated per IMO (SOLAS'90) Rules for Passenger Ships)

	Available	Required
Static Heel Angle	2.81S deg	7.00 deg
Angle at Maximum GZ	40.00S deg	
Maximum GZ	1.347 ft	1.020 ft
Range of Positive GZ	47.19 deg	15.00 deg
Righting Area (2.81-‡.00)	12.601 ft-deg	2.820 ft-deg

RTRN006B:
 91' CREW BOAT B

Managed Compartments:
 AUX ER FO TANK STBD

	DISPLACEMENT LTons	DRAFT AFT ft	DRAFT FWD ft	TRIM ft	HEEL deg.	UPRIGHT GMT ft
INTACT	70.8	3.100	3.000	0.100A	0.00	5.223
DAMAGED	79.9	3.456	3.045	0.411A	4.73S	3.295

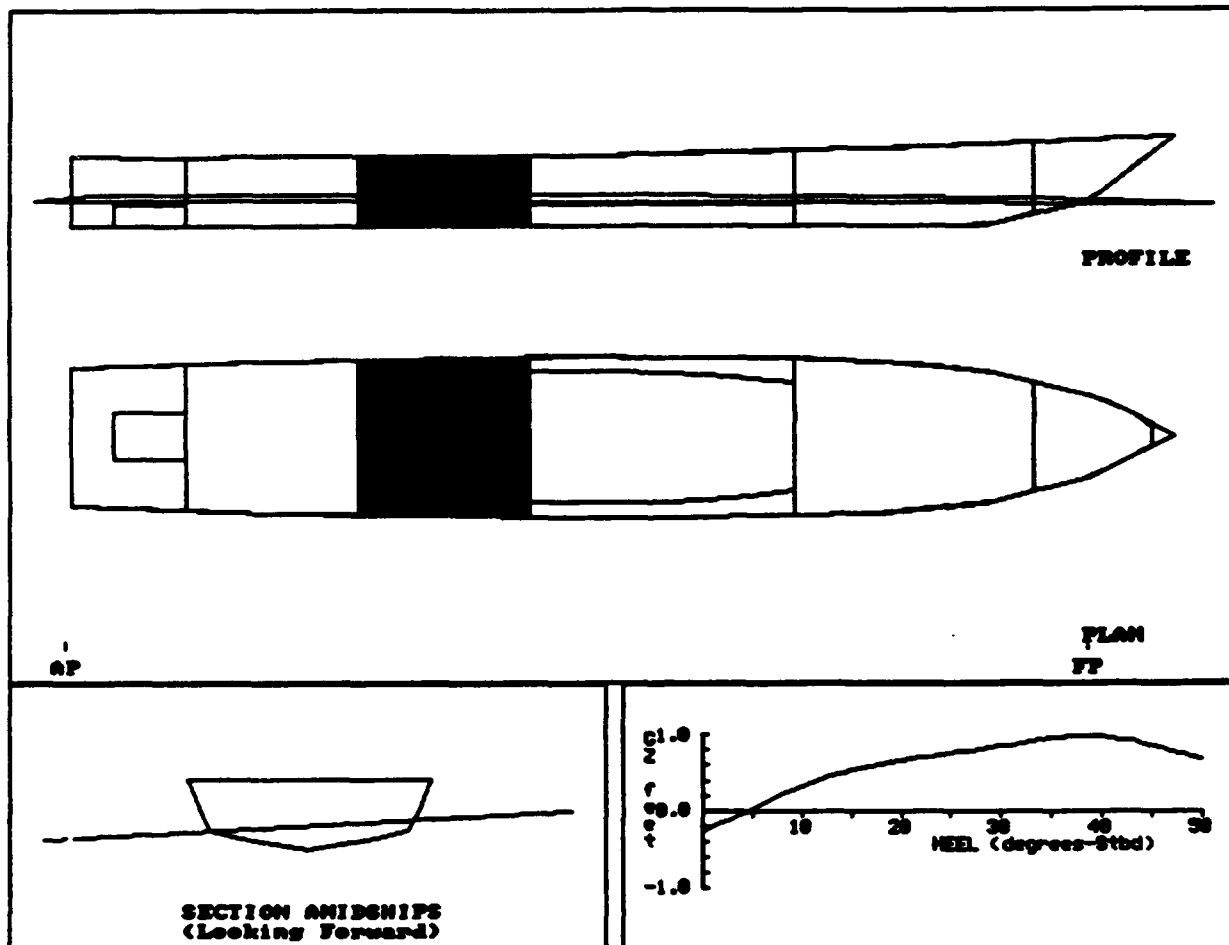

RTRN006B:
 91' CREW BOAT B

COMPARTMENT FLOODING SUMMARY

At 4.7oS Heel	PERM.	FLOODED WTR LTons	% FULL (Damaged)	% FULL (Intact)	SP.VOL. ft3/LT	OUTFLOW LTons
AUX ER	0.85	3.5	FREE	0.0	----	----
FO TANK STBD	0.95	6.2	FREE	10.0	35.0063	0.6
Totals		9.7				0.6

INTACT DATA

Draft at AP = 3.100 ft	Kmt = 14.063 ft	LCG = 53.702A ft-FP
Draft at FP = 3.000 ft	VCG = 8.840 ft	LCB = 53.710A ft-FP
Displacement = 70.8 LTons	Gmt = 5.223 ft	TCG = 0.000 ft-CL

DRAFT/GZ DATA

HEEL degrees	RIGHTING ARM ft	DRAFT AFT ft	DRAFT FWD ft	FLOODED WATER LTons
0.00	-0.277	3.453	3.077	9.6
5.00S	0.017	3.456	3.042	9.8
7.00S	0.147	3.460	3.015	10.1
10.00S	0.318	3.449	2.962	10.8
20.00S	0.662	3.238	2.627	13.0
30.00S	0.849	2.697	2.053	15.0
40.00S	0.977	1.762	1.072	16.4
50.00S	0.674	0.572	-0.576	16.8

Note: Drafts are measured at A.P. and F.P along ship's centerline

GZ SUMMARY (Evaluated per IMO (SOLAS'90) Rules for Passenger Ships)
 Available Required

Static Heel Angle	4.73S deg	7.00 deg
Angle at Maximum GZ	40.00S deg	
*** Maximum GZ	0.983 ft	1.020 ft
Range of Positive GZ	45.27 deg	15.00 deg
Righting Area (4.73-8.00)	7.380 ft-deg	2.820 ft-deg

*** indicates failure to meet criterion

RTRN007B:
 91' CREW BOAT B

Imaged Compartments:
 ENGINE ROOM

	DISPLACEMENT LTons	DRAFT AFT ft	DRAFT FWD ft	TRIM ft	HEEL deg.	UPRIGHT Gmt ft
INTACT	70.8	3.100	3.000	0.100A	0.00	5.223
DAMAGED	89.5	4.393	2.433	1.960A	0.00	3.712

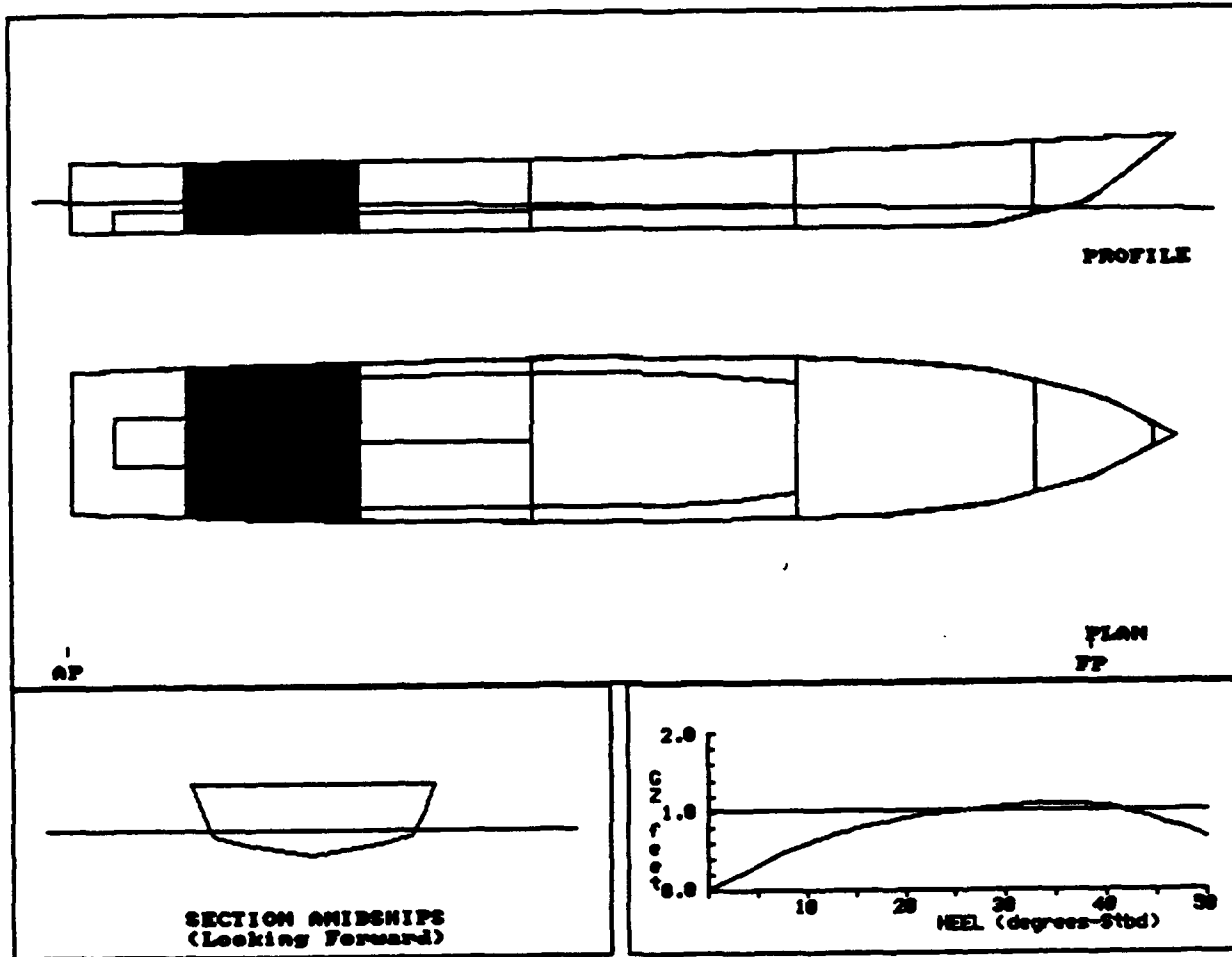

RTRN007B:
 91' CREW BOAT B

COMPARTMENT FLOODING SUMMARY

At 0.0o Heel	PERM.	FLOODED WTR LTons	% FULL (Damaged)	% FULL (Intact)	SP.VOL. ft3/LT	OUTFLOW LTons
ENGINE ROOM	0.85	18.8	FREE	0.0	----	----
Totals		18.8				

INTACT DATA

Draft at AP = 3.100 ft	KMT = 14.063 ft	LCG = 53.702A ft-FP
Draft at FP = 3.000 ft	VCG = 8.840 ft	LCB = 53.710A ft-FP
Displacement = 70.8 LTons	GMT = 5.223 ft	TCG = 0.000 ft-CL

DRAFT/GZ DATA

HEEL degrees	RIGHTING ARM ft	DRAFT AFT ft	DRAFT FWD ft	FLOODED WATER LTons
0.00	0.000	4.393	2.433	18.8
5.00S	0.319	4.386	2.397	18.8
7.00S	0.436	4.379	2.362	18.7
10.00S	0.590	4.360	2.286	18.7
20.00S	0.915	4.152	1.853	18.5
30.00S	1.060	3.614	1.160	18.4
40.00S	1.053	2.840	-0.071	18.2
50.00S	0.677	1.999	-2.101	18.2

Note: Drafts are measured at A.P. and F.P along ship's centerline

GZ SUMMARY (Evaluated per IMO (SOLAS'90) Rules for Passenger Ships)
 Available Required

Static Heel Angle	0.00 deg	7.00 deg
Angle at Maximum GZ	36.00S deg	
Maximum GZ	1.095 ft	1.020 ft
Range of Positive GZ	50.00 deg	15.00 deg
Gmt (upright damaged)	3.712 ft	
Righting Area (0.00- 7 .00)	12.710 ft-deg	2.820 ft-deg

RTRN008B:
 91' CREW BOAT B

Damaged Compartments:
 LAZARETTE

	DISPLACEMENT LTons	DRAFT AFT ft	DRAFT FWD ft	TRIM ft	HEEL deg.	UPRIGHT GMT ft
INTACT	70.8	3.100	3.000	0.100A	0.00	5.223
DAMAGED	80.4	4.021	2.370	1.652A	0.00	4.034

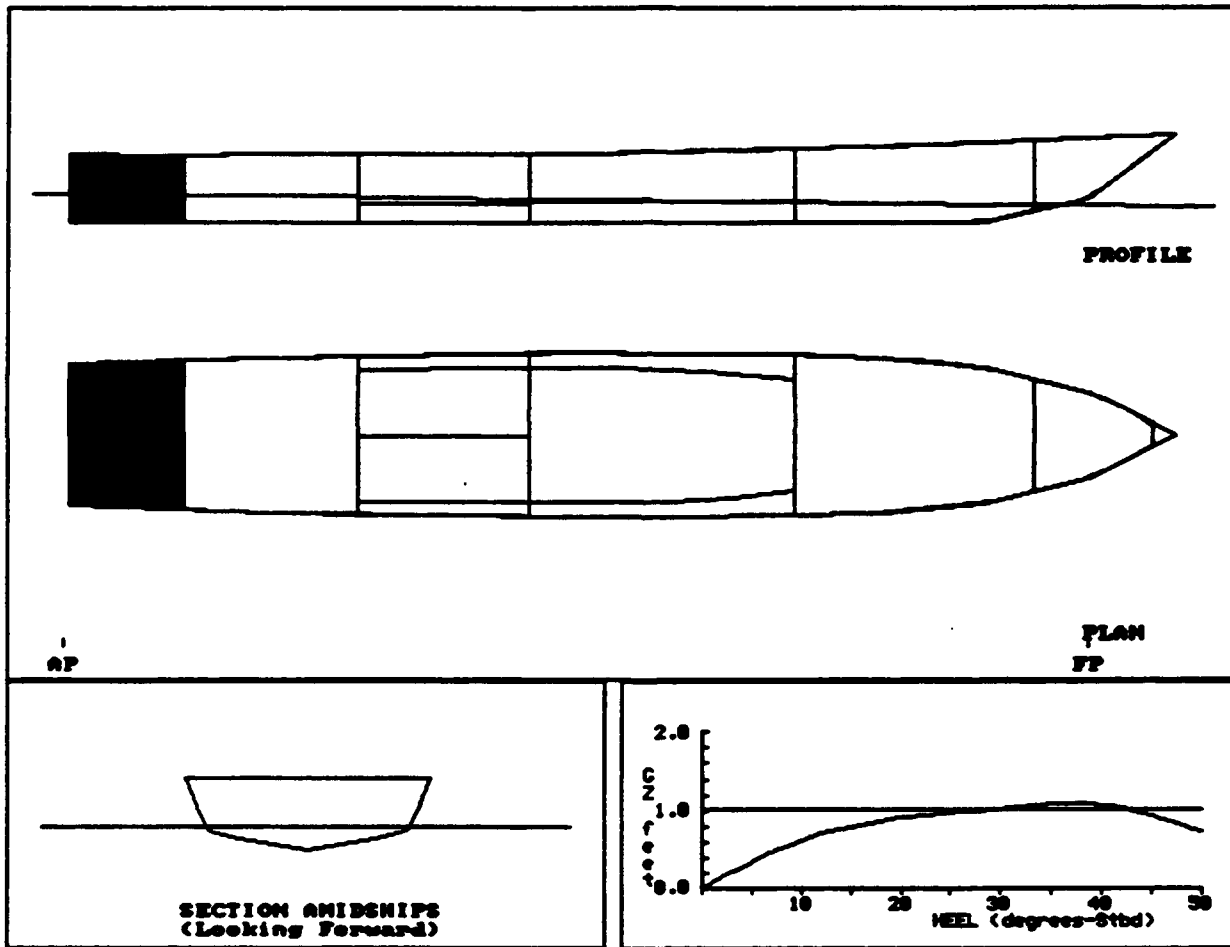

RTRN008B:
 91' CREW BOAT B

COMPARTMENT FLOODING SUMMARY

At 0.0o Heel	PERM.	FLOODED WTR LTons	% FULL (Damaged)	% FULL (Intact)	SP.VOL. ft3/LT	OUTFLOW LTons
LAZARETTE	0.90	9.6	FREE	0.0	----	----
Totals		9.6				

INTACT DATA

Draft at AP = 3.100 ft	KMt = 14.063 ft	LCG = 53.702A ft-FP
Draft at FP = 3.000 ft	VCG = 8.840 ft	LCB = 53.710A ft-FP
Displacement = 70.8 LTons	Gmt = 5.223 ft	TCG = 0.000 ft-CL

DRAFT/GZ DATA

HEEL degrees	RIGHTING ARM ft	DRAFT AFT ft	DRAFT FWD ft	FLOODED WATER LTons
0.00	0.000	4.021	2.370	9.6
5.00S	0.345	4.021	2.324	9.6
7.00S	0.469	4.016	2.283	9.6
10.00S	0.625	3.993	2.200	9.6
20.00S	0.906	3.721	1.776	9.3
30.00S	1.023	3.155	1.066	9.4
40.00S	1.072	2.330	-0.196	9.9
50.00S	0.733	1.435	-2.364	10.6

Note: Drafts are measured at A.P. and F.P along ship's centerline

GZ SUMMARY (Evaluated per IMO (SOLAS'90) Rules for Passenger Ships)

	Available	Required
Static Heel Angle	0.00 deg	7.00 deg
Angle at Maximum GZ	38.00S deg	
Maximum GZ	1.091 ft	1.020 ft
Range of Positive GZ	50.00 deg	15.00 deg
Gmt (upright damaged)	4.034 ft	
Righting Area (0.00-%.00)	13.086 ft-deg	2.820 ft-deg

RTRN009B:
 91' CREW BOAT B

Imaged Compartments:
 LAZARETTE POT N20 TANK

	DISPLACEMENT LTons	DRAFT AFT ft	DRAFT FWD ft	TRIM ft	HEEL deg.	UPRIGHT Gmt ft
INTACT	70.8	3.100	3.000	0.100A	0.00	5.223
DAMAGED	84.5	4.407	2.102	2.305A	0.00	4.169

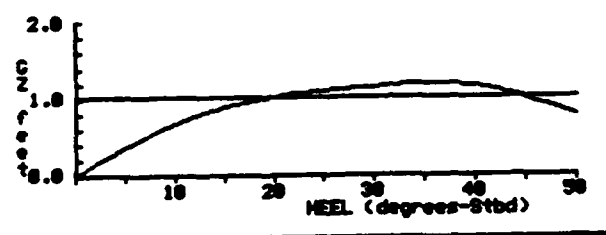
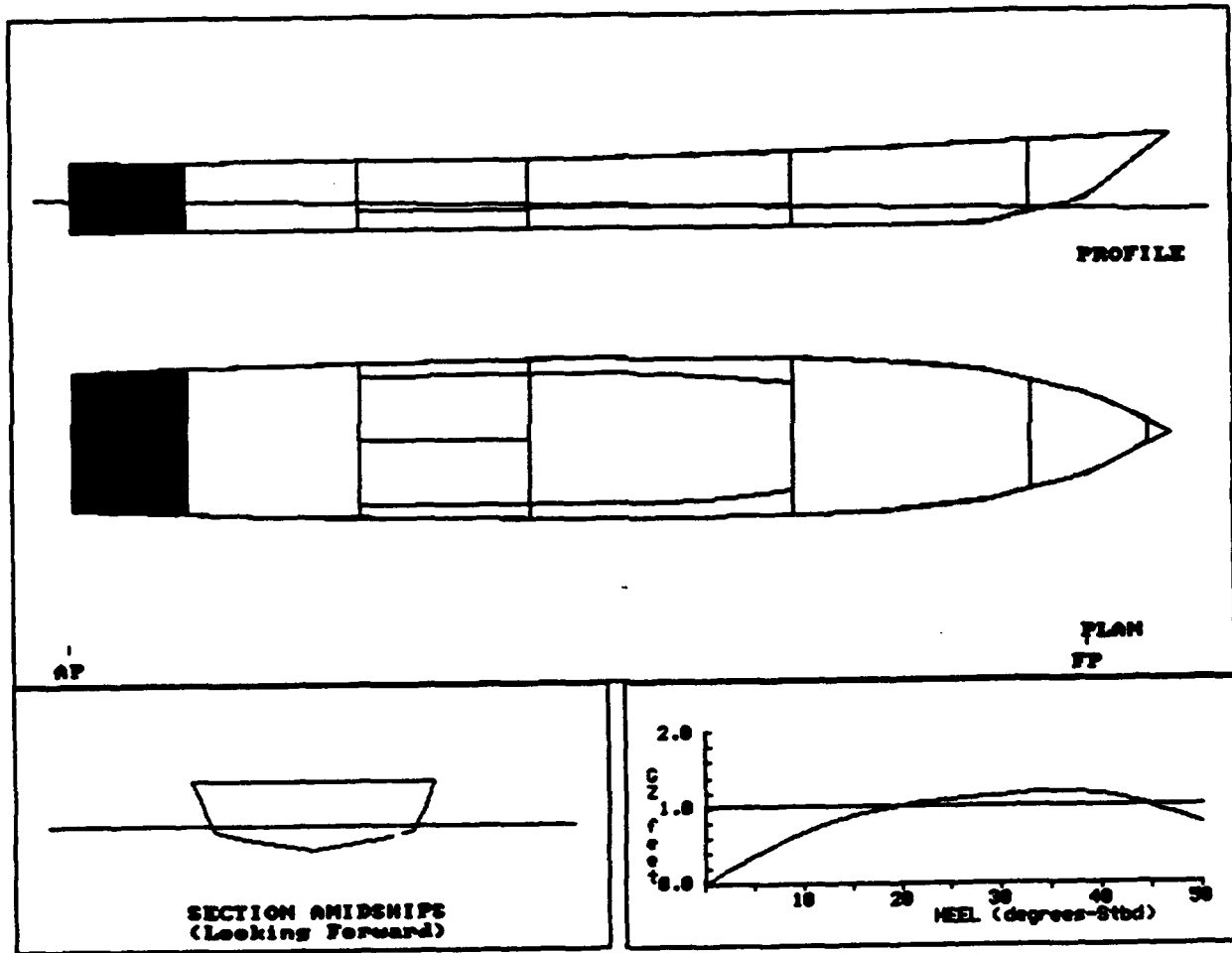

RTRN009B:
 91' CREW BOAT B

COMPARTMENT FLOODING SUMMARY

At 0.0o Heel	PERM.	FLOODED WTR LTons	% FULL (Damaged)	% FULL (Intact)	SP.VOL. ft ³ /LT	OUTFLOW LTons
LAZARETTE	0.90	11.1	FREE	0.0	----	----
POT H2O TANK	0.95	2.9	FREE	10.0	34.1500	0.3
Totals		14.1				0.3

INTACT DATA

Draft at AP = 3.100 ft KMT = 14.063 ft LCG = 53.702A ft-FP
 Draft at FP = 3.000 ft VCG = 8.840 ft LCB = 53.710A ft-FP
 Displacement = 70.8 LTons GMT = 5.223 ft TCG = 0.000 ft-CL

DRAFT/GZ DATA

HEEL degrees	RIGHTING ARM ft	DRAFT AFT ft	DRAFT FWD ft	FLOODED WATER LTons
0.00	0.000	4.407	2.102	14.1
5.00S	0.360	4.405	2.058	14.1
7.00S	0.492	4.402	2.015	14.1
10.00S	0.666	4.388	1.927	14.1
20.00S	1.018	4.155	1.477	13.7
30.00S	1.151	3.589	0.744	13.2
40.00S	1.158	2.691	-0.442	12.6
50.00S	0.770	1.790	-2.613	12.5

Note: Drafts are measured at A.P. and F.P along ship's centerline

GZ SUMMARY (Evaluated per IMO (SOLAS'90) Rules for Passenger Ships)
 Available Required

Static Heel Angle	0.00 deg	7.00 deg
Angle at Maximum GZ	37.00S deg	
Maximum GZ	1.195 ft	1.020 ft
Range of Positive GZ	50.00 deg	15.00 deg
Gmt (upright damaged)	4.169 ft	
Righting Area (0.00-1.00)	14.262 ft-deg	2.820 ft-deg

DAMAGE STABILITY SUMMARY
91' CREW BOAT B

CA No.	FILE NAME	DAMAGED COMP. LISTING	---Intact Condition---			-----Equilibrium Condition After Damage-----					
			MM.DRAFT (ft)	VCG (ft)	Ght (ft)	HEEL (deg)	MAX.GZ (ft)	RANGE (deg)	AREA (ft-deg)	DAM.Ght (ft)	SURVIVAL
1	RKG1001C	1	3.050	7.900	6.163	0.0	1.775	50.00	19.22	6.109	Yes
2	RKG1002C	2	3.050	7.900	6.163	0.0	1.803	50.00	20.19	6.027	Yes
3	RKG1003C	3	3.050	7.900	6.163	0.0	1.066	50.00	11.85	2.895	Yes
4	RKG1004C	5	3.050	7.900	6.163	0.0	1.439	50.00	14.41	3.736	Yes
5	RKG1005C	6	3.050	7.900	6.163	2.4S	1.954	47.60	16.50	----	Yes
6	RKG1006C	5,6	3.050	7.900	6.163	3.7S	1.587	46.27	11.19	----	Yes
7	RKG1007C	8	3.050	7.900	6.163	0.0	1.663	50.00	16.63	4.653	Yes
8	RKG1008C	9	3.050	7.900	6.163	0.0	1.677	50.00	17.01	4.976	Yes
9	RKG1009C	9,10	3.050	7.900	6.163	0.0	1.770	50.00	18.20	5.116	Yes
10	RKG1010C	3,4	3.050	7.900	6.163	0.0	1.109	50.00	11.78	2.557	Yes

RKG1001C:
 91' CREW BOAT B

COMPARTMENT FLOODING SUMMARY

At 0.0o Heel	PERM.	FLOODED WTR LTons	% FULL (Damaged)	% FULL (Intact)	SP.VOL. ft3/LT	OUTFLOW LTons
FOREPEAK	0.95	0.1	FREE	0.0	----	----
Totals		0.1				

INTACT DATA

Draft at AP = 3.100 ft Kmt = 14.063 ft LCG = 53.703A ft-FP
 Draft at FP = 3.000 ft VCG = 7.900 ft LCB = 53.710A ft-FP
 Displacement = 70.8 LTons Gmt = 6.163 ft TCG = 0.000 ft-CL

DRAFT/GZ DATA

HEEL degrees	RIGHTING ARM ft	DRAFT AFT ft	DRAFT FWD ft	FLOODED WATER LTons
0.00	0.000	3.095	3.011	0.1
5.00S	0.515	3.089	2.969	0.1
7.00S	0.689	3.075	2.932	0.1
10.00S	0.904	3.028	2.861	0.0
20.00S	1.349	2.660	2.494	0.0
30.00S	1.584	1.945	1.891	0.0
40.00S	1.774	0.792	0.857	0.0
50.00S	1.669	-0.829	-0.842	0.0

Note: Drafts are measured at A.P. and F.P along ship's centerline

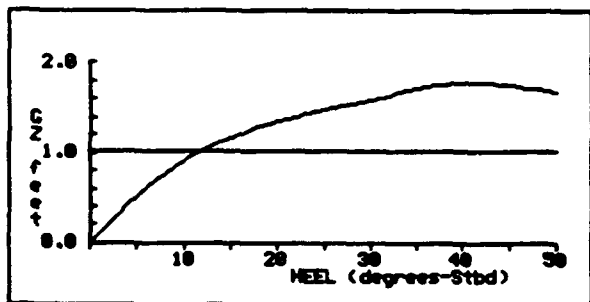

Static Heel = 0.0 deg
 Draft at AP = 3.095 ft
 Draft at FP = 3.011 ft

Gmt (upright damaged) = 6.109 ft
 Angle at Maximum GZ = 42.00S deg
 Maximum GZ = 1.775 ft
 Range of Positive GZ = 50.00 deg

Area to 22.0 degrees = 19.22 ft-deg

RKG1002C:
 91' CREW BOAT B

COMPARTMENT FLOODING SUMMARY

At 0.0o Heel	PERM.	FLOODED WTR LTons	% FULL (Damaged)	% FULL (Intact)	SP.VOL. ft3/LT	OUTFLOW LTons
CREW	0.95	16.0	FREE	0.0	----	----
Totals		16.0				

INTACT DATA

Draft at AP = 3.100 ft Kmt = 14.063 ft LCG = 53.703A ft-FP
 Draft at FP = 3.000 ft VCG = 7.900 ft LCB = 53.710A ft-FP
 Displacement = 70.8 LTons GMT = 6.163 ft TCG = 0.000 ft-CL

DRAFT/GZ DATA

HEEL degrees	RIGHTING ARM ft	DRAFT AFT ft	DRAFT FWD ft	FLOODED WATER LTons
0.00	0.000	2.473	4.679	16.0
5.00S	0.525	2.461	4.664	16.0
7.00S	0.714	2.437	4.656	16.0
10.00S	0.947	2.378	4.621	16.0
20.00S	1.432	1.962	4.370	15.9
30.00S	1.679	1.226	3.821	15.4
40.00S	1.797	0.004	3.008	15.3
50.00S	1.526	-1.874	2.053	16.1

Note: Drafts are measured at A.P. and F.P along ship's centerline

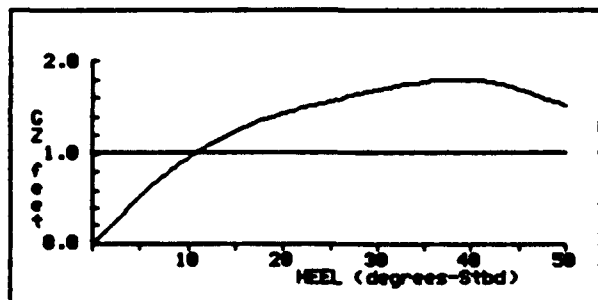

Static Heel = 0.0 deg
 Draft at AP = 2.473 ft
 Draft at FP = 4.679 ft

Gmt (upright damaged) = 6.637 ft
 Angle at Maximum GZ = 39.000 deg
 Maximum GZ = 1.800 ft
 Range of Positive GZ = 50.00 deg

Area to 22.0 degrees = 20.19 ft-deg

RKG1003C:
 91' CREW BOAT B

COMPARTMENT FLOODING SUMMARY

At 0.0o Heel	PERM.	FLOODED WTR LTons	% FULL (Damaged)	% FULL (Intact)	SP.VOL. ft3/LT	OUTFLOW LTons
PASSENGERS	0.95	0.8	FREE	0.0	----	----
Totals		0.8				

INTACT DATA

Draft at AP = 3.100 ft Kmt = 14.063 ft LCG = 53.703A ft-FP
 Draft at FP = 3.000 ft VCG = 7.900 ft LCB = 53.710A ft-FP
 Displacement = 70.8 LTons GMT = 6.163 ft TCG = 0.000 ft-CL

DRAFT/GZ DATA

HEEL degrees	RIGHTING ARM ft	DRAFT AFT ft	DRAFT FWD ft	FLOODED WATER LTons
0.00	0.000	3.092	3.059	0.8
5.00S	0.316	3.096	3.131	2.9
7.00S	0.430	3.081	3.160	3.9
10.00S	0.568	3.047	3.167	5.3
20.00S	0.821	2.688	3.131	9.8
30.00S	0.942	1.997	2.882	14.2
40.00S	1.066	0.882	2.315	18.5
50.00S	0.931	-0.597	1.246	21.1

Note: Drafts are measured at A.P. and F.P along ship's centerline

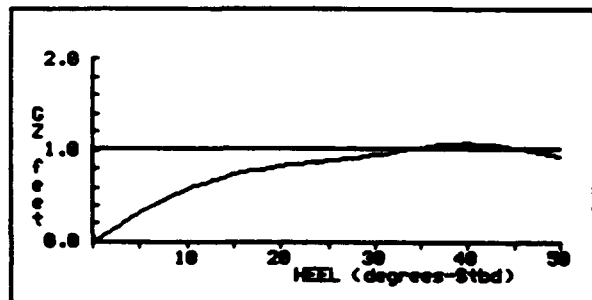

Static Heel = 0.0 deg
 Draft at AP = 3.092 ft
 Draft at FP = 3.059 ft

Gmt (upright damaged) = 2.895 ft
 Angle at Maximum GZ = 41.886 deg
 Maximum GZ = 1.066 ft
 Range of Positive GZ = 50.00 deg

Area to 22.0 degrees = 11.85 ft-deg

RKG1004C:
 91' CREW BOAT B

COMPARTMENT FLOODING SUMMARY

At 0.0o Heel	PERM.	FLOODED WTR LTons	% FULL (Damaged)	% FULL (Intact)	SP.VOL. ft3/LT	OUTFLOW LTons
AUX ER	0.85	2.1	FREE	0.0	----	----
Totals		2.1				

INTACT DATA

Draft at AP = 3.100 ft KMT = 14.063 ft LCG = 53.703A ft-FP
 Draft at FP = 3.000 ft VCG = 7.900 ft LCB = 53.710A ft-FP
 Displacement = 70.8 LTons GMT = 6.163 ft TCG = 0.000 ft-CL

DRAFT/GZ DATA

HEEL degrees	RIGHTING ARM ft	DRAFT AFT ft	DRAFT FWD ft	FLOODED WATER LTons
0.00	0.000	3.184	3.019	2.1
5.00S	0.355	3.200	2.980	2.6
7.00S	0.496	3.208	2.947	3.1
10.00S	0.673	3.189	2.894	3.8
20.00S	1.039	2.944	2.558	6.0
30.00S	1.248	2.369	1.983	8.0
40.00S	1.439	1.389	1.007	9.9
50.00S	1.281	0.138	-0.649	11.2

Note: Drafts are measured at A.P. and F.P along ship's centerline

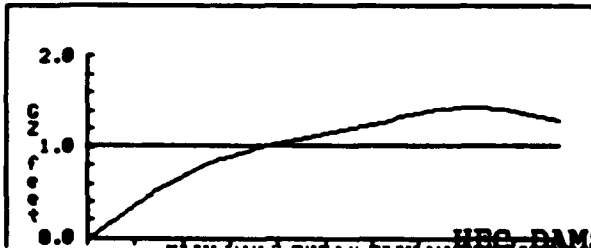

Static Heel = 0.0 deg
 Draft at AP = 3.184 ft
 Draft at FP = 3.019 ft
 Gmt (upright damaged) = 3.736 ft
 Angle at Maximum GZ = 41.00S deg
 Maximum GZ = 1.439 ft
 Range of Positive GZ = 50.00 deg

RKG1005C:
 91' CREW BOAT B

COMPARTMENT FLOODING SUMMARY

At 2.4oS Heel	PERM.	FLOODED WTR LTons	% FULL (Damaged)	% FULL (Intact)	SP.VOL. ft3/LT	OUTFLOW LTons
FO TANK STBD	0.95	6.2	FREE	10.0	35.0063	0.6
Totals		6.2				0.6

INTACT DATA

Draft at AP = 3.100 ft KMT = 14.063 ft LCG = 53.703A ft-FP
 Draft at FP = 3.000 ft VCG = 7.900 ft LCB = 53.710A ft-FP
 Displacement = 70.8 LTons GMT = 6.163 ft TCG = 0.000 ft-CL

DRAFT/GZ DATA

HEEL degrees	RIGHTING ARM ft	DRAFT AFT ft	DRAFT FWD ft	FLOODED WATER LTons
0.00	-0.277	3.319	3.047	6.2
5.00S	0.287	3.309	3.019	6.2
7.00S	0.490	3.299	2.984	6.2
10.00S	0.751	3.262	2.914	6.2
20.00S	1.333	2.926	2.552	6.2
30.00S	1.686	2.235	1.952	6.0
40.00S	1.952	1.076	0.944	5.4
50.00S	1.789	-0.511	-0.786	4.2

Note: Drafts are measured at A.P. and F.P along ship's centerline

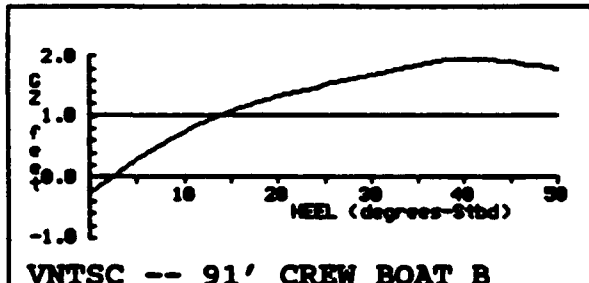

Static Heel = 2.45 deg
 Draft at AP = 3.315 ft
 Draft at FP = 3.038 ft

Angle at Maximum GZ = 47.68 deg
 Maximum GZ = 1.954 ft
 Range of Positive GZ = 47.68 deg

Area to 22.0 degrees = 16.58 ft-deg

VNTSC -- 91' CREW BOAT B
 Project No. SOLAS90 (by: MDYER)

-----HEC-DAMSTB V
 04-05-1994

**REG1006C:
 91' CREW BOAT B**

COMPARTMENT FLOODING SUMMARY

At 3.7oS Heel	PERM.	FLOODED WTR LTons	% FULL (Damaged)	% FULL (Intact)	SP.VOL. ft ³ /LT	OUTFLOW LTons
AUX ER	0.85	3.4	FREE	0.0	----	----
FO TANK STBD	0.95	6.2	FREE	10.0	35.0063	0.6
Totals		9.6				0.6

INTACT DATA

Draft at AP = 3.100 ft Kmt = 14.063 ft LCG = 53.703A ft-FP
 Draft at FP = 3.000 ft VCG = 7.900 ft LCB = -53.710A ft-FP

Displacement = 70.8 LTons GMT = 6.163 ft TCG = 0.000 ft-CL

DRAFT/GS DATA

HEEL degrees	RIGHTING ARM ft	DRAFT AFT ft	DRAFT FWD ft	FLOODED WATER LTons
0.00	-0.277	3.453	3.077	9.6
5.00S	0.099	3.456	3.042	9.8
7.00S	0.263	3.459	3.016	10.1
10.00S	0.483	3.448	2.963	10.8
20.00S	0.987	3.238	2.628	13.0
30.00S	1.324	2.696	2.054	15.0
40.00S	1.587	1.761	1.073	16.4
50.00S	1.400	0.571	-0.575	16.8

Note: Drafts are measured at A.P. and F.P along ship's centerline

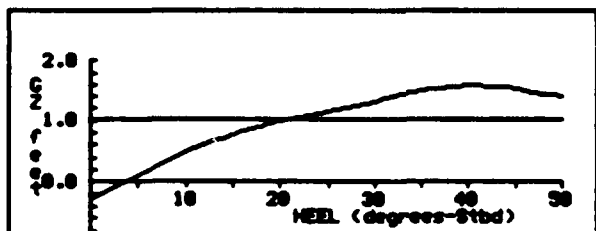

Static Heel = 3.78 deg
 Draft at AP = 3.454 ft
 Draft at FP = 3.054 ft

Angle at Maximum GE = 41.00S deg
 Maximum GE = 1.587 ft
 Range of Positive GE = 46.27 deg

Area to 22.0 degrees = 11.19 ft-deg

(s3B VNTSC -- 91' CREW BOAT B
 Project No. SOLAS90 (by: MDYER)

HEC-DAM
 04-05-1994

**REG1007C:
 91' CREW BOAT B**

COMPARTMENT FLOODING SUMMARY

At 0.0o Heel	PERM.	FLOODED WTR LTons	% FULL (Damaged)	% FULL (Intact)	SP.VOL. ft3/LT	OUTFLOW LTons
ENGINE ROOM	0.85	18.8	FREE	0.0	----	----
Totals		18.8				

INTACT DATA

Draft at AP = 3.100 ft KMT = 14.063 ft LCG = 53.703A ft-FP
 Draft at FP = 3.000 ft VCG = 7.900 ft LCB = 53.710A ft-FP

Displacement = 70.8 LTons Gmt = 6.163 ft TCG = 0.000 ft-CL

DRAFT/GZ DATA

HEEL degrees	RIGHTING ARM ft	DRAFT AFT ft	DRAFT FWD ft	FLOODED WATER LTons
0.00	0.000	4.391	2.436	18.8
5.00S	0.401	4.382	2.402	18.7
7.00S	0.551	4.375	2.367	18.7
10.00S	0.753	4.356	2.291	18.7
20.00S	1.236	4.147	1.858	18.5
30.00S	1.530	3.610	1.166	18.4
40.00S	1.657	2.835	-0.065	18.2
50.00S	1.398	1.992	-2.093	18.2

Note: Drafts are measured at A.P. and F.P along ship's centerline

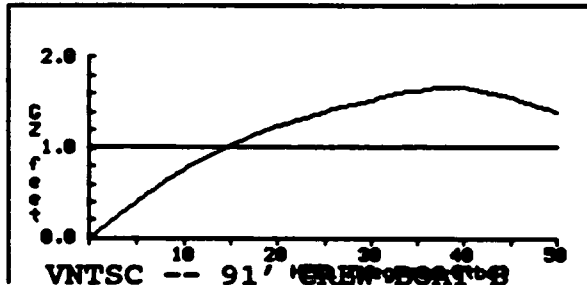

Static Heel = 0.0 deg
 Draft at AP = 4.391 ft
 Draft at FP = 2.436 ft

Gmt (upright damaged) = 4.633 ft
 Angle at Maximum GZ = 22.8 deg
 Maximum GZ = 1.663 ft
 Range of Positive GZ = 58.88 deg

Area to 22.8 degrees = 16.63 ft-deg

Project No. SOLAS90 (by: MDYER)

HEC-DAMSTB
 04-05-1994

**RKG1008C:
 91' CREW BOAT B**

COMPARTMENT FLOODING SUMMARY

At 0.0o Heel	PERM.	FLOODED WTR LTons	% FULL (Damaged)	% FULL (Intact)	SP.VOL. ft3/LT	OUTFLOW LTons
LAZARETTE	0.90	9.6	FREE	0.0	----	----
Totals		9.6				

INTACT DATA

Draft at AP = 3.100 ft Kmt = 14.063 ft LCG = 53.703A ft-FP
 Draft at FP = 3.000 ft VCG = 7.900 ft LCB = 53.710A ft-FP
 Displacement = 70.8 LTons Gmt = 6.163 ft TCG = -0.000 ft-CL

DRAFT/GZ DATA

HEEL degrees	RIGHTING ARM ft	DRAFT AFT ft	DRAFT FWD ft	FLOODED WATER LTons
0.00	0.000	4.019	2.372	9.6
5.00S	0.427	4.017	2.328	9.6
7.00S	0.584	4.012	2.288	9.6
10.00S	0.788	3.989	2.205	9.6
20.00S	1.228	3.717	1.781	9.3
30.00S	1.493	3.151	1.071	9.4
40.00S	1.677	2.325	-0.191	9.9
50.00S	1.454	1.428	-2.356	10.6

Note: Drafts are measured at A.P. and F.P along ship's centerline

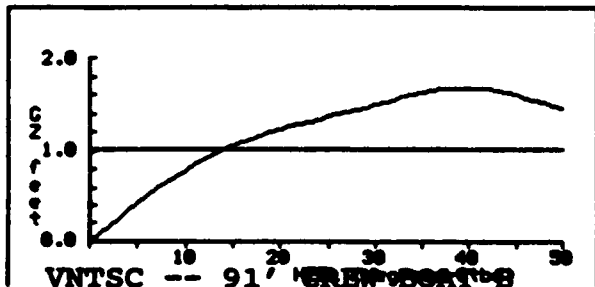

Static Heel = 0.0 deg
 Draft at AP = 4.019 ft
 Draft at FP = 2.372 ft

Get (upright damaged) = 4.976 ft
 Angle at Maximum GZ = 41.000 deg
 Maximum GZ = 1.677 ft
 Range of Positive GZ = 50.00 deg

Area to 22.0 degrees = 17.61 ft-deg

Project No. SOLAS90 (by: MDYER)

HEC-DAMSTB
 04-05-1994

**RKG1009C:
 91' CREW BOAT B**

COMPARTMENT FLOODING SUMMARY

At 0.0o Heel	PERM.	FLOODED WTR LTons	% FULL (Damaged)	% FULL (Intact)	SP.VOL. ft3/LT	OUTFLOW LTons
LAZARETTE	0.90	11.1	FREE	0.0	----	----
POT H2O TANK	0.95	2.9	FREE	10.0	34.1500	0.3
Totals		14.0				0.3

INTACT DATA

Draft at AP = 3.100 ft KMT = 14.063 ft LCG = 53.703A ft-FP
 Draft at FP = 3.000 ft VCG = 7.900 ft LCB = 53.710A ft-FP

Displacement = 70.8 LTons GMT = 6.163 ft TCG = 0.000 ft-CL

DRAFT/GZ DATA

HEEL degrees	RIGHTING ARM ft	DRAFT AFT ft	DRAFT FWD ft	FLOODED WATER LTons
0.00	0.000	4.400	2.112	14.0
5.00S	0.442	4.400	2.064	14.1
7.00S	0.607	4.396	2.022	14.1
10.00S	0.831	4.382	1.934	14.1
20.00S	1.340	4.148	1.485	13.7
30.00S	1.623	3.583	0.752	13.2
40.00S	1.765	2.683	-0.434	12.6
50.00S	1.494	1.780	-2.602	12.5

Note: Drafts are measured at A.P. and F.P along ship's centerline

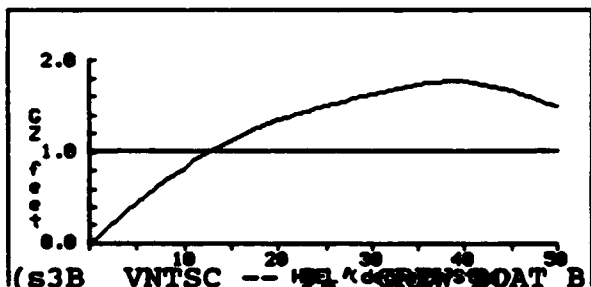

Static Heel = 0.0 deg
Draft at AP = 4.400 ft
Draft at FP = 2.112 ft

Gmt (upright damaged) = 5.116 ft
Angle at Maximum GZ = 40.00S deg
Maximum GZ = 1.770 ft
Range of Positive GZ = 30.00 deg

Area to 22.0 degrees = 10.20 ft-deg

(s3B VNTSC -- 91' CREW BOAT B
Project No. SOLAS90 (by: MDYER)

HEC-DAM

04-05-1994

**REG1010C:
91' CREW BOAT B**

COMPARTMENT FLOODING SUMMARY

At 0.0o Heel	PERM.	FLOODED WTR LTons	% FULL (Damaged)	% FULL (Intact)	SP.VOL. ft3/LT	OUTFLOW LTons
PASSENGERS	0.95	2.5	FREE	0.0	----	----
PASSGR VOID	0.14	2.8	FREE	0.0	----	----
Totals		5.3				

INTACT DATA

Draft at AP = 3.100 ft KMT = 14.063 ft LCG = -53.703A ft-FP

RKG1010C:
 91' CREW BOAT B

COMPARTMENT FLOODING SUMMARY

At 0.0o Heel	PERM.	FLOODED WTR LTons	% FULL (Damaged)	% FULL (Intact)	SP.VOL. ft3/LT	OUTFLOW LTons
PASSENGERS	0.95	2.5	FREE	0.0	----	----
PASSGR VOID	0.14	2.8	FREE	0.0	----	----
Totals		5.3				

INTACT DATA

Draft at AP = 3.100 ft Kmt = 14.063 ft LCG = 53.703A ft-FP
 Draft at FP = 3.000 ft VCG = 7.900 ft LCB = 53.710A ft-FP
 Displacement = 70.8 LTons GMT = 6.163 ft TCG = 0.000 ft-CL

DRAFT/GZ DATA

HEEL degrees	RIGHTING ARM ft	DRAFT AFT ft	DRAFT FWD ft	FLOODED WATER LTons
0.00	0.000	3.103	3.304	5.3
5.00S	0.292	3.092	3.351	6.5
7.00S	0.414	3.092	3.351	7.3
10.00S	0.560	3.051	3.364	8.5
20.00S	0.837	2.698	3.304	12.6
30.00S	0.976	2.012	3.026	16.6
40.00S	1.109	0.903	2.440	20.4
50.00S	0.967	-0.567	1.362	22.6

Note: Drafts are measured at A.P. and F.P along ship's centerline

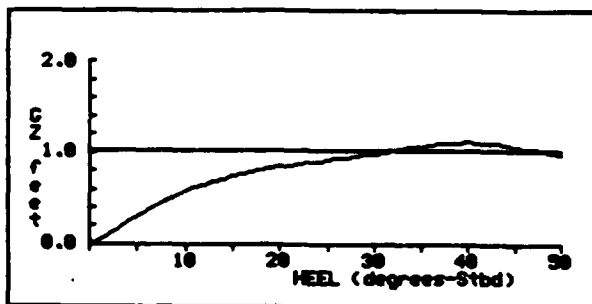

Static Heel = 0.0 deg
 Draft at AP = 3.103 ft
 Draft at FP = 3.304 ft

Gmt (upright damaged) = 2.557 ft
 Angle at Maximum GZ = 41.000 deg
 Maximum GZ = 1.109 ft
 Range of Positive GZ = 50.00 deg

Area to 22.0 degrees = 11.78 ft-deg

DAMAGE STABILITY SUMMARY
91' CREW BOAT B

→ $GZ_{req'd} = 0.48$ for 68 PAX.

ASE No.	FILE NAME	DAMAGED COMP. LISTING	---Intact Condition---			-----Equilibrium Condition After Damage-----					
			MN.DRAFT (ft)	VCG (ft)	GMT (ft)	HEEL (deg)	MAX.GZ (ft)	RANGE (deg)	AREA (ft-deg)	DAM.GMT (ft)	SURVIVAL
1	RTN2001B	1	3.050	8.840	5.223	0.0	1.177	50.00	15.30	5.169	Yes
2	RTN2002B	2	3.050	8.840	5.223	0.0	1.236	50.00	16.27	5.088	Yes
3	RTN2003B	3	3.050	8.840	5.223	0.0	0.500	50.00	7.93	1.955	Yes
4	RTN2004B	4	3.050	8.840	5.223	0.0	0.845	50.00	10.48	2.796	Yes
5	RTN2005B	5	3.050	8.840	5.223	2.8s	1.347	47.19	12.60	----	Yes
6	RTN2006B	4,5	3.050	8.840	5.223	4.7s	0.983	45.27	7.38	----	Yes
7	RTN2007B	7	3.050	8.840	5.223	0.0	1.095	50.00	12.71	3.712	Yes
8	RTN2008B	8	3.050	8.840	5.223	0.0	1.091	50.00	13.09	4.034	Yes
9	RTN2009B	8,9	3.050	8.840	5.223	0.0	1.195	50.00	14.26	4.169	Yes

Case 10 added: Compartments 3 (Passenger) and 10 (Passenger Void).
 Compit. 10 extends to 3 feet AOL and is filled w/foam @
 permeability = 0.14.

RTN2001B:
 91' CREW BOAT B

COMPARTMENT FLOODING SUMMARY

At 0.0o Heel	PERM.	FLOODED WTR LTons	% FULL (Damaged)	% FULL (Intact)	SP.VOL. ft3/LT	OUTFLOW LTons
FOREPEAK	0.95	0.1	FREE	0.0	----	----
Totals		0.1				

INTACT DATA

Draft at AP = 3.100 ft KMT = 14.063 ft LCG = 53.702A ft-FP
 Draft at FP = 3.000 ft VCG = 8.840 ft LCB = 53.710A ft-FP
 Displacement = 70.8 LTons GMT = 5.223 ft TCG = 0.000 ft-CL

DRAFT/GZ DATA

HEEL degrees	RIGHTING ARM ft	DRAFT AFT ft	DRAFT FWD ft	FLOODED WATER LTons
0.00	0.000	3.095	3.011	0.1
5.00S	0.433	3.089	2.969	0.1
7.00S	0.574	3.075	2.931	0.1
10.00S	0.741	3.028	2.860	0.0
20.00S	1.027	2.660	2.494	0.0
30.00S	1.114	1.945	1.891	0.0
40.00S	1.169	0.792	0.857	0.0
50.00S	0.949	-0.829	-0.841	0.0

Note: Drafts are measured at A.P. and F.P along ship's centerline

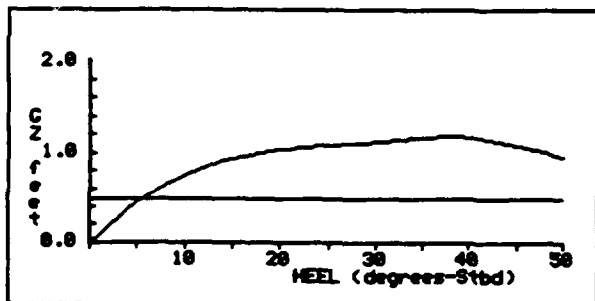

Static Heel = 0.0 deg
 Draft at AP = 3.095 ft
 Draft at FP = 3.011 ft

Gm (upright damaged) = 5.169 ft
 Angle at Maximum GZ = 39.00S deg
 Maximum GZ = 1.177 ft
 Range of Positive GZ = 50.00 deg

Area to 22.0 degrees = 15.30 ft-deg

RTN2002B:
 91' CREW BOAT B

COMPARTMENT FLOODING SUMMARY

At 0.0o Heel	PERM.	FLOODED WTR LTons	% FULL (Damaged)	% FULL (Intact)	SP.VOL. ft3/LT	OUTFLOW LTons
CREW	0.95	16.0	FREE	0.0	----	----
Totals		16.0				

INTACT DATA

Draft at AP = 3.100 ft Kmt = 14.063 ft LCG = 53.702A ft-FP
 Draft at FP = 3.000 ft VCG = 8.840 ft LCB = 53.710A ft-FP
 Displacement = 70.8 LTons GMT = 5.223 ft TCG = 0.000 ft-CL

DRAFT/GZ DATA

HEEL degrees	RIGHTING ARM ft	DRAFT AFT ft	DRAFT FWD ft	FLOODED WATER LTons
0.00	0.000	2.467	4.687	16.0
5.00S	0.443	2.457	4.672	16.0
7.00S	0.599	2.432	4.664	16.1
10.00S	0.783	2.373	4.628	16.1
20.00S	1.111	1.957	4.378	15.9
30.00S	1.209	1.220	3.830	15.4
40.00S	1.193	-0.001	3.015	15.3
50.00S	0.805	-1.881	2.064	16.2

Note: Drafts are measured at A.P. and F.P along ship's centerline

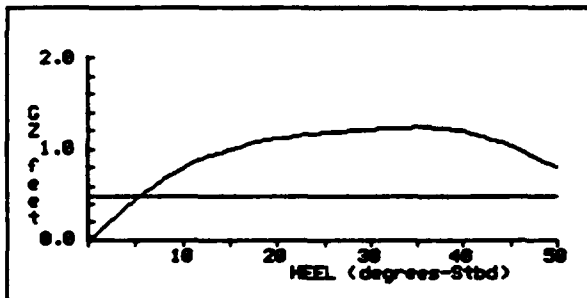

Static Heel = 0.0 deg
 Draft at AP = 2.467 ft
 Draft at FP = 4.687 ft

Gmt (upright damaged) = 5.888 ft
 Angle at Maximum GZ = 36.885 deg
 Maximum GZ = 1.236 ft
 Range of Positive GZ = 50.00 deg

Area to 22.0 degrees = 16.27 ft-deg

RTN2003B:
 91' CREW BOAT B

COMPARTMENT FLOODING SUMMARY

At 0.0o Heel	PERM.	FLOODED WTR LTons	% FULL (Damaged)	% FULL (Intact)	SP.VOL. ft3/LT	OUTFLOW LTons
PASSENGERS	0.95	0.8	FREE	0.0	----	----
Totals		0.8				

INTACT DATA

Draft at AP = 3.100 ft	KMt = 14.063 ft	LCG = 53.702A ft-FP
Draft at FP = 3.000 ft	VCG = 8.840 ft	LCB = 53.710A ft-FP
Displacement = 70.8 LTons	Gmt = 5.223 ft	TCG = 0.000 ft-CL

DRAFT/GZ DATA

HEEL degrees	RIGHTING ARM ft	DRAFT AFT ft	DRAFT FWD ft	FLOODED WATER LTons
0.00	0.000	3.092	3.059	0.8
5.00S	0.234	3.096	3.132	2.9
7.00S	0.315	3.081	3.160	3.9
10.00S	0.405	3.047	3.167	5.3
20.00S	0.499	2.687	3.132	9.8
30.00S	0.471	1.995	2.884	14.2
40.00S	0.462	0.880	2.317	18.5
50.00S	0.211	-0.599	1.249	21.1

Note: Drafts are measured at A.P. and F.P along ship's centerline

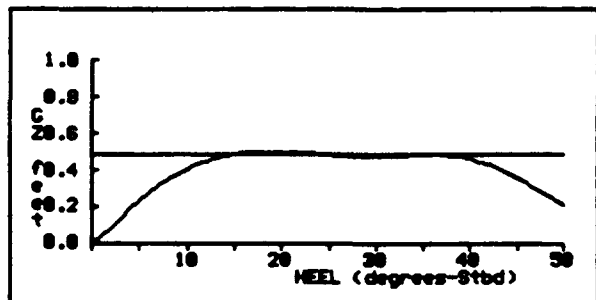

Static Heel = 0.0 deg
 Draft at AP = 3.092 ft
 Draft at FP = 3.059 ft

Gmt (upright damaged) = 1.955 ft
 Angle at Maximum GZ = 20.000 deg
 Maximum GZ = 0.500 ft
 Range of Positive GZ = 50.00 deg

Area to 22.0 degrees = 7.93 ft-deg

RTN2004B:
 91' CREW BOAT B

COMPARTMENT FLOODING SUMMARY

At 0.0o Heel	PERM.	FLOODED WTR LTons	% FULL (Damaged)	% FULL (Intact)	SP.VOL. ft3/LT	OUTFLOW LTons
AUX ER	0.85	2.1	FREE	0.0	----	----
Totals		2.1				

INTACT DATA

Draft at AP = 3.100 ft Kmt = 14.063 ft LCG = 53.702A ft-FP
 Draft at FP = 3.000 ft VCG = 8.840 ft LCB = 53.710A ft-FP
 Displacement = 70.8 LTons GMT = 5.223 ft TCG = 0.000 ft-CL

DRAFT/GZ DATA

HEEL degrees	RIGHTING ARM ft	DRAFT AFT ft	DRAFT FWD ft	FLOODED WATER LTons
0.00	0.000	3.184	3.019	2.1
5.00S	0.273	3.200	2.980	2.6
7.00S	0.381	3.208	2.947	3.1
10.00S	0.510	3.189	2.893	3.8
20.00S	0.717	2.944	2.557	6.0
30.00S	0.778	2.369	1.982	8.0
40.00S	0.835	1.390	1.006	9.9
50.00S	0.561	0.139	-0.650	11.2

Note: Drafts are measured at A.P. and F.P along ship's centerline

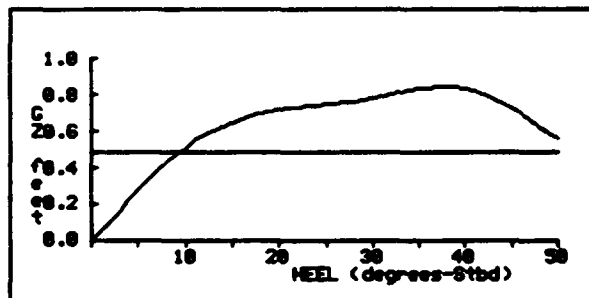

Static Heel = 0.0 deg
 Draft at AP = 3.184 ft
 Draft at FP = 3.019 ft

Gmt (upright damaged) = 2.796 ft
 Angle at Maximum GZ = 39.886 deg
 Maximum GZ = 0.845 ft
 Range of Positive GZ = 58.88 deg

Area to 22.8 degrees = 18.48 ft-deg

RTN2005B:
 91' CREW BOAT B

COMPARTMENT FLOODING SUMMARY

At 2.8oS Heel	PERM.	FLOODED WTR LTons	% FULL (Damaged)	% FULL (Intact)	SP.VOL. ft3/LT	OUTFLOW LTons
FO TANK STBD	0.95	6.2	FREE	10.0	35.0063	0.6
Totals		6.2				0.6

INTACT DATA

Draft at AP = 3.100 ft Kmt = 14.063 ft LCG = 53.702A ft-FP
 Draft at FP = 3.000 ft VCG = 8.840 ft LCB = 53.710A ft-FP
 Displacement = 70.8 LTons GMT = 5.223 ft TCG = 0.000 ft-CL

DRAFT/GZ DATA

HEEL degrees	RIGHTING ARM ft	DRAFT AFT ft	DRAFT FWD ft	FLOODED WATER LTons
0.00	-0.277	3.319	3.048	6.2
5.00S	0.205	3.310	3.018	6.2
7.00S	0.374	3.299	2.983	6.2
10.00S	0.586	3.262	2.914	6.2
20.00S	1.009	2.926	2.552	6.2
30.00S	1.212	2.235	1.951	6.0
40.00S	1.343	1.076	0.944	5.4
50.00S	1.063	-0.523	-0.771	4.2

Note: Drafts are measured at A.P. and F.P along ship's centerline

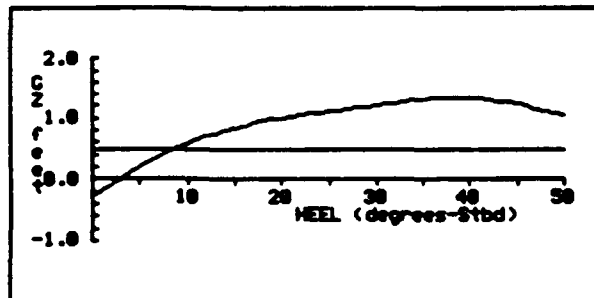

Static Heel = 2.85 deg
 Draft at AP = 3.315 ft
 Draft at FP = 3.036 ft

Angle at Maximum GZ = 48.885 deg
 Maximum GZ = 1.347 ft
 Range of Positive GZ = 47.19 deg

Area to 22.0 degrees = 12.60 ft-deg

RTN2006B:
91' CREW BOAT B

COMPARTMENT FLOODING SUMMARY

At 4.7oS Heel	PERM.	FLOODED WTR LTons	% FULL (Damaged)	% FULL (Intact)	SP.VOL. ft3/LT	OUTFLOW LTons
AUX ER	0.85	3.5	FREE	0.0	----	----
FO TANK STBD	0.95	6.2	FREE	10.0	35.0063	0.6
Totals		9.7				0.6

INTACT DATA

Draft at AP = 3.100 ft KMT = 14.063 ft LCG = 53.702A ft-FP
 Draft at FP = 3.000 ft VCG = 8.840 ft LCB = 53.710A ft-FP
 Displacement = 70.8 LTons GMT = 5.223 ft TCG = 0.000 ft-CL

DRAFT/GZ DATA

HEEL degrees	RIGHTING ARM ft	DRAFT AFT ft	DRAFT FWD ft	FLOODED WATER LTons
0.00	-0.277	3.453	3.077	9.6
5.00S	0.017	3.456	3.042	9.8
7.00S	0.147	3.460	3.015	10.1
10.00S	0.318	3.449	2.962	10.8
20.00S	0.662	3.238	2.627	13.0
30.00S	0.849	2.697	2.053	15.0
40.00S	0.977	1.762	1.072	16.4
50.00S	0.674	0.572	-0.576	16.8

Note: Drafts are measured at A.P. and F.P along ship's centerline

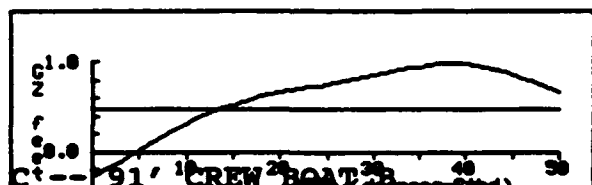

Static Heel = 4.78 deg
 Draft at AP = 3.456 ft
 Draft at FP = 3.045 ft

Angle at Maximum GZ = 45.2 DEG
 Maximum GZ = 0.983 ft
 Range of Positive GZ = 45.2 DEG

RTN2007B:
91' CREW BOAT B

COMPARTMENT FLOODING SUMMARY

At 0.0o Heel	PERM.	FLOODED WTR LTons	% FULL (Damaged)	% FULL (Intact)	SP.VOL. ft3/LT	OUTFLOW LTons
ENGINE ROOM	0.85	18.8	FREE	0.0	----	----
Totals		18.8				

INTACT DATA

Draft at AP = 3.100 ft KMT = 14.063 ft LCG = 53.702A ft-FP
 Draft at FP = 3.000 ft VCG = 8.840 ft LCB = 53.710A ft-FP
 Displacement = 70.8 LTons GMT = 5.223 ft TCG = 0.000 ft-CL

DRAFT/GZ DATA

HEEL degrees	RIGHTING ARM ft	DRAFT AFT ft	DRAFT FWD ft	FLOODED WATER LTons
0.00	0.000	4.393	2.433	18.8
5.00S	0.319	4.386	2.397	18.8
7.00S	0.436	4.379	2.362	18.7
10.00S	0.590	4.360	2.286	18.7
20.00S	0.915	4.152	1.853	18.5
30.00S	1.060	3.614	1.160	18.4
40.00S	1.053	2.840	-0.071	18.2
50.00S	0.677	1.999	-2.101	18.2

Note: Drafts are measured at A.P. and F.P along ship's centerline

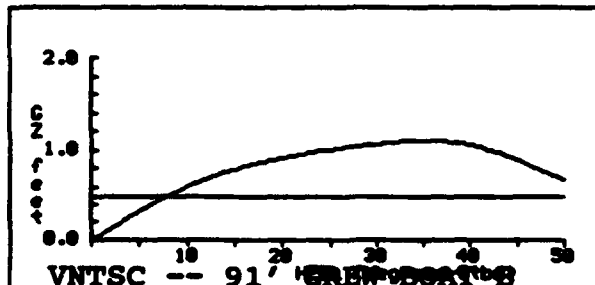

Static Heel = 0.0 deg
 Draft at AP = 4.393 ft
 Draft at FP = 2.433 ft

Gut (upright damaged) = 3.712 ft
 Angle at Maximum GZ = 22.8 deg
 Maximum GZ = 1.095 ft
 Range of Positive GZ = 38.88 deg

Area to 22.8 degrees = 12.71 ft-deg

Project No. SOLAS90 (by: MDYER)

HEC-DAMSTB
 04-05-1994

**RTH2008B:
 91' CREW BOAT B**

COMPARTMENT FLOODING SUMMARY

At 0.00 Heel	PERM.	FLOODED WTR LTons	% FULL (Damaged)	% FULL (Intact)	SP.VOL. ft3/LT	OUTFLOW LTons
LAZARETTE	0.90	9.6	FREE	0.0	----	----
Totals		9.6				

INTACT DATA

Draft at AP = 3.100 ft Kmt = 14.063 ft LCG = 53.702A ft-FP
 Draft at FP = 3.000 ft VCG = 8.840 ft LCB = 53.710A ft-FP
 Displacement = 70.8 LTons GMT = 5.223 ft TCG = -0.000 ft-CL

DRAFT/GZ DATA

HEEL degrees	RIGHTING ARM ft	DRAFT AFT ft	DRAFT FWD ft	FLOODED WATER LTons
0.00	0.000	4.021	2.370	9.6
5.00S	0.345	4.021	2.324	9.6
7.00S	0.469	4.016	2.283	9.6
10.00S	0.625	3.993	2.200	9.6
20.00S	0.906	3.721	1.776	9.3
30.00S	1.023	3.155	1.066	9.4
40.00S	1.072	2.330	-0.196	9.9
50.00S	0.733	1.435	-2.364	10.6

Note: Drafts are measured at A.P. and F.P along ship's centerline

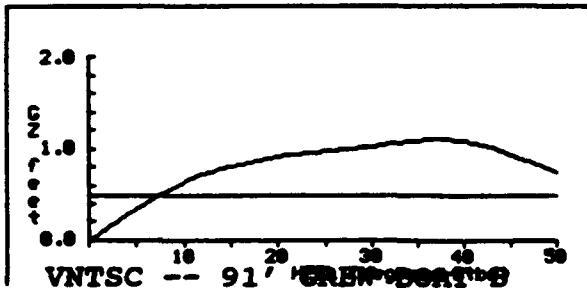

Static Heel = 0.0 deg
 Draft at AP = 4.021 ft
 Draft at FP = 2.370 ft

Gzt (upright damaged) = 4.034 ft
 Angle at Maximum GZ = 38.00S deg
 Maximum GZ = 1.091 ft
 Range of Positive GZ = 58.00 deg

Area to 22.0 degrees = 13.09 ft-deg

Project No. SOLAS90 (by: MDYER)

HEC-DAMSTB
 04-05-1994

**RTM2009B:
 91' CREW BOAT B**

COMPARTMENT FLOODING SUMMARY

At 0.00 Heel	PERM.	FLOODED WTR LTons	% FULL (Damaged)	% FULL (Intact)	SP.VOL. ft3/LT	OUTFLOW LTons
LAZARETTE	0.90	11.1	FREE	0.0	----	----
POT H2O TANK	0.95	2.9	FREE	10.0	34.1500	0.3
Totals		14.1				0.3

INTACT DATA

Draft at AP = 3.100 ft KMT = 14.063 ft LCG = 53.702A ft-FP
 Draft at FP = 3.000 ft VCG = 8.840 ft LCB = 53.710A ft-FP

Draft at FP = 3.000 ft
 Displacement = 70.8 LTons

VCG = 8.840 ft
 GMt = 5.223 ft

LCB = 53.710A ft-FP
 TCG = 0.000 ft-CL

DRAFT/GZ DATA

HEEL degrees	RIGHTING ARM ft	DRAFT AFT ft	DRAFT FWD ft	FLOODED WATER LTons
0.00	0.000	3.102	3.305	5.3
5.00S	0.210	3.091	3.352	6.5
7.00S	0.300	3.091	3.352	7.3
10.00S	0.397	3.051	3.364	8.5
20.00S	0.515	2.697	3.305	12.6
30.00S	0.505	2.010	3.028	16.6
40.00S	0.505	0.901	2.443	20.4
50.00S	0.247	-0.569	1.364	22.6

Note: Drafts are measured at A.P. and F.P along ship's centerline

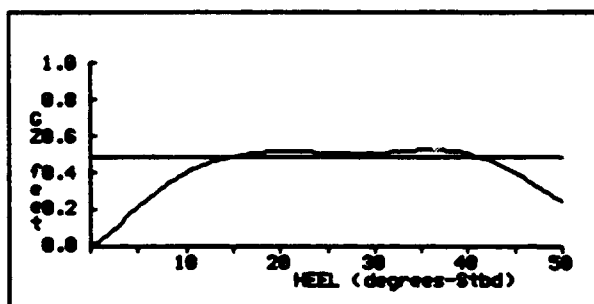

Static Heel = 0.0 deg
 Draft at AP = 3.102 ft
 Draft at FP = 3.305 ft

Gmt (upright damaged) = 1.618 ft
 Angle at Maximum GZ = 37.000 deg
 Maximum GZ = 0.525 ft
 Range of Positive GZ = 50.00 deg

Area to 22.0 degrees = 7.86 ft-deg

Displacement = 70.8 LTons GMt = 5.223 ft TCG = 0.000 ft-CL

DRAFT/GZ DATA

HEEL degrees	RIGHTING ARM ft	DRAFT AFT ft	DRAFT FWD ft	FLOODED WATER LTons
0.00	0.000	4.407	2.102	14.1
5.00S	0.360	4.405	2.058	14.1
7.00S	0.492	4.402	2.015	14.1
10.00S	0.666	4.388	1.927	14.1
20.00S	1.018	4.155	1.477	13.7
30.00S	1.151	3.589	0.744	13.2
40.00S	1.158	2.691	-0.442	12.6
50.00S	0.770	1.790	-2.613	12.5

Note: Drafts are measured at A.P. and F.P. along ship's centerline

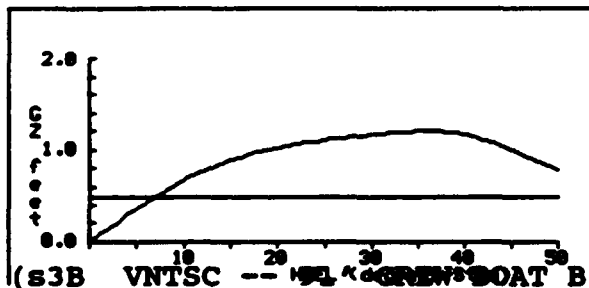

Static Heel = 0.0 deg
 Draft at AP = 4.407 ft
 Draft at FP = 2.102 ft

Gmt (upright damaged) = 4.169 ft
 Angle at Maximum GZ = 37.00S deg
 Maximum GZ = 1.195 ft
 Range of Positive GZ = 50.00 deg

Area to 22.0 degrees = 14.26 ft-deg

Project No. SOLAS90 (by: MDYER)

HEC-DAM
05-13-1994

91' CREW BOAT B

COMPARTMENT FLOODING SUMMARY

At 0.0c Heel	PERM.	FLOODED WTR LTons	% FULL (Damaged)	% FULL (Intact)	SP.VOL. ft ³ /LT	OUTFLOW LTons
PASSENGERS	0.95	2.5	FREE	0.0	----	----
PASSGR VOID	0.14	2.8	FREE	0.0	----	----
Totals		5.3				

INTACT DATA

Draft at AP = 3.100 ft KMT = 14.063 ft LCG = 53.702A ft-FP

**APPENDIX B
HYDROSTATICS AND
DAMAGE STABILITY
OUTPUT**

99' CREW BOAT

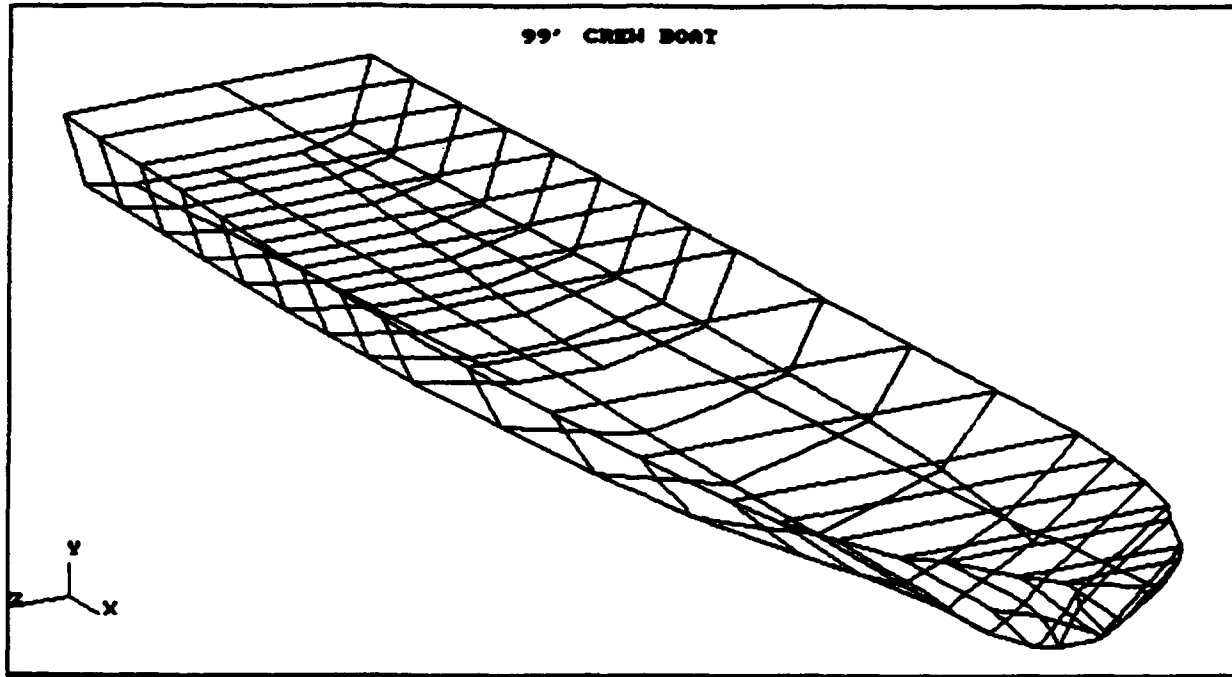

DAMAGE STABILITY SUMMARY
99' CREW BOAT

CASE No.	FILE NAME	DAMAGED COMP. LISTING	---Intact Condition---			-----Equilibrium Condition After Damage-----					SURVIVAL
			MN.DRAFT (ft)	VCG (ft)	GMT (ft)	HEEL (deg)	MAX.GZ (ft)	RANGE (deg)	AREA (ft-deg)	DAM.GMT (ft)	
1	DPRT001A	1	3.610	8.630	4.669	0.0	1.425	50.00	16.73	4.729	Yes
2	DPRT002A	2	3.610	8.630	4.669	0.0	1.435	50.00	16.89	4.518	Yes
3	DPRT003A	4	3.610	8.630	4.669	0.0	1.131	50.00	11.33	2.597	Yes
4	DPRT004A	5	3.610	8.630	4.669	0.0	0.975	50.00	10.48	2.877	Yes
5	DPRT005A	5,6	3.610	8.630	4.669	0.3P	0.718	49.67	7.96	----	No *F
6	DPRT006A	5,6,7	3.610	8.630	4.669	2.0P	0.651	47.98	6.53	----	No *F
7	DPRT007A	5,7	3.610	8.630	4.669	1.3P	0.919	48.74	9.20	----	Yes
8	DPRT008A	10	3.610	8.630	4.669	0.0	1.189	50.00	12.93	3.158	Yes

*F WARNING: The required GMT for non-survival cases does not meet all survival criteria.

DAMAGE STABILITY SUMMARY
99' CREW BOAT

Ca	No.	FILE NAME	DAMAGED COMP. LISTING	---Intact Condition---			-----Equilibrium Condition After Damage-----					
				MN.DRAFT (ft)	VCG (ft)	GMt (ft)	HEEL (deg)	MAX.G2 (ft)	RANGE (deg)	AREA (ft-deg)	DAM.GMt (ft)	SURVIVAL
	1	RTRN001A	1	3.440	9.010	5.018	0.0	1.245	50.00	16.59	5.105	Yes
	2	RTRN002A	2	3.440	9.010	5.018	0.0	1.260	50.00	16.77	4.903	Yes
	3	RTRN003A	4	3.440	9.010	5.018	0.0	0.997	50.00	11.08	2.696	Yes
	4	RTRN004A	5	3.440	9.010	5.018	0.0	0.900	50.00	10.36	2.954	No *F
	5	RTRN005A	5,6	3.440	9.010	5.018	4.9S	0.818	45.10	6.17	----	No *F
	6	RTRN006A	5,6,7	3.440	9.010	5.018	4.7S	0.799	45.26	6.15	----	No *F
	7	RTRN007A	5,7	3.440	9.010	5.018	0.1P	0.892	49.87	10.21	----	No *F
	8	RTRN008A	10	3.440	9.010	5.018	0.0	1.122	50.00	12.65	3.280	Yes

*F WARNING: The required GMt for non-survival cases does not meet all survival criteria.

HYDROSTATIC TABLES
 99' CREW BOAT

HOLDED DRAFT (ft)		2.000	2.250	2.500	2.750	3.000	3.250	3.500	3.750	4.000	4.500
DISP.MLD.	(LTons-SW)	23	30	38	46	55	64	73	82	92	111
DISP.TOTAL	(LTons-SW)	23	30	38	47	55	64	73	83	92	112
DISP.TOTAL	(LTons-FW)	23	30	37	45	54	63	72	81	90	109
LCB	(ft-FP)	51.234A	52.127A	52.654A	52.887A	52.941A	52.897A	52.800A	52.672A	52.534A	52.249A
LCB (forebody)	(ft-FP)	30.149A	30.024A	29.914A	29.822A	29.743A	29.648A	29.535A	29.409A	29.279A	29.018A
LCB (aftbody)	(ft-FP)	65.549A	66.110A	66.407A	66.528A	66.586A	66.628A	66.660A	66.684A	66.703A	66.728A
TCB	(ft-CL)	0.000	0.000	0.000	0.000	0.000	0.000	0.000	0.000	0.000	0.000
KB	(ft)	1.436	1.599	1.758	1.914	2.065	2.212	2.357	2.500	2.641	2.921
BMT	(ft)	15.859	16.947	16.591	15.199	13.753	12.468	11.398	10.516	9.730	8.545
KMT	(ft)	17.294	18.546	18.350	17.113	15.818	14.680	13.755	13.016	12.372	11.466
BML	(ft)	550.294	469.269	398.108	344.908	305.054	274.066	249.268	228.630	210.818	183.211
KML	(ft)	551.730	470.868	399.866	346.822	307.118	276.278	251.625	231.130	213.459	186.132
TPI	(LTons)	2.2	2.5	2.7	2.8	2.9	3.0	3.1	3.1	3.2	3.3
MTlin	(ft-LTons)	12	13	14	15	16	16	17	17	18	19
CDTlin	(LTons)	0.2	0.3	0.3	0.3	0.3	0.2	0.2	0.2	0.2	0.2
LCF	(ft-FP)	54.953A	54.963A	54.345A	53.574A	52.917A	52.368A	51.898A	51.501A	51.207A	50.667A
W.P. AREA	(ft2)	943	1,054	1,137	1,191	1,231	1,263	1,291	1,316	1,336	1,375
WETTED SUR.	(ft2)	1,008	1,133	1,236	1,315	1,384	1,447	1,507	1,565	1,620	1,728
MAX. BEAM	(ft)	14.769	16.490	17.550	17.895	18.031	18.168	18.305	18.441	18.578	18.851
LENGTH W.L.	(ft)	86.588	87.069	87.550	87.939	88.328	88.717	89.106	89.495	89.884	90.662
Cb		0.2490	0.2898	0.3286	0.3641	0.3962	0.4249	0.4509	0.4745	0.4961	0.5340
ebody)		0.2013	0.2246	0.2477	0.2706	0.2934	0.3156	0.3367	0.3568	0.3756	0.4101
C _w	(body)	0.2966	0.3550	0.4095	0.4576	0.4989	0.5343	0.5651	0.5923	0.6165	0.6579
Cm		0.3684	0.4096	0.4503	0.4907	0.5298	0.5646	0.5966	0.6249	0.6501	0.6934
Cp		0.6758	0.7075	0.7296	0.7420	0.7478	0.7527	0.7558	0.7594	0.7630	0.7701
Cwp		0.5819	0.6506	0.7018	0.7352	0.7599	0.7797	0.7969	0.8123	0.8248	0.8490
Cit		0.2924	0.4093	0.5048	0.5637	0.6054	0.6378	0.6662	0.6931	0.7151	0.7605

Assumes: Sea Water at 35.0063 ft3/LT
 Fresh Water at 35.8814 ft3/LT
 Ship floating at even keel (no heel or trim)

DAMAGE STABILITY SUMMARY
99' CREW BOAT

CASE No.	FILE NAME	DAMAGED COMP. LISTING	---Intact Condition---			-----Equilibrium Condition After Damage-----					
			MN.DRAFT (ft)	VCG (ft)	GMt (ft)	HEEL (deg)	MAX.GZ (ft)	RANGE (deg)	AREA (ft-deg)	DAM.GMt (ft)	SURVIVAL
1	DPTA001A	1	3.610	8.160	5.139	0.0	1.695	50.00	18.69	5.198	Yes
2	DPTA002A	2	3.610	8.160	5.139	0.0	1.687	50.00	18.85	4.988	Yes
3	DPTA003A	4	3.610	8.160	5.139	0.0	1.369	50.00	13.29	3.066	Yes
4	DPTA004A	5	3.610	8.160	5.139	0.0	1.215	50.00	12.44	3.348	Yes
5	DPTA005A	5,6	3.610	8.160	5.139	0.3P	0.965	49.73	10.02	----	Yes
6	DPTA006A	5,6,7	3.610	8.160	5.139	1.7P	0.903	48.33	8.61	----	Yes
7	DPTA007A	5,7	3.610	8.160	5.139	1.1P	1.164	48.92	11.19	----	Yes
8	DPTA008A	10	3.610	8.160	5.139	0.0	1.425	50.00	14.89	3.630	Yes

DAMAGE STABILITY SUMMARY
99' CREW BOAT

CASE No.	FILE NAME	DAMAGED COMP. LISTING	---Intact Condition---			-----Equilibrium Condition After Damage-----					
			MN.DRAFT (ft)	VCG (ft)	Ght (ft)	HEEL (deg)	MAX.GZ (ft)	RANGE (deg)	AREA (ft-deg)	DAM.Ght (ft)	SURVIVAL
1	RTNA001A	1	3.440	8.500	5.528	0.0	1.539	50.00	18.72	5.615	Yes
2	RTNA002A	2	3.440	8.500	5.528	0.0	1.528	50.00	18.90	5.413	Yes
3	RTNA003A	4	3.440	8.500	5.528	0.0	1.256	50.00	13.20	3.205	Yes
4	RTNA004A	5	3.440	8.500	5.528	0.0	1.163	50.00	12.49	3.464	Yes
5	RTNA005A	5,6	3.440	8.500	5.528	4.1S	1.090	45.92	8.23	----	Yes
6	RTNA006A	5,6,7	3.440	8.500	5.528	3.9S	1.070	46.06	8.21	----	Yes
7	RTNA007A	5,7	3.440	8.500	5.528	0.1P	1.156	49.89	12.35	----	Yes
8	RTNA008A	10	3.440	8.500	5.528	0.0	1.385	50.00	14.78	3.791	Yes

DPERT001A:
 99' CREW BOAT

Damaged Compartments:
 FOREPEAK

	DISPLACEMENT LTons	DRAFT AFT ft	DRAFT FWD ft	TRIM ft	HEEL deg.	UPRIGHT GMT ft
INTACT	78.3	3.750	3.470	0.280A	0.00	4.669
DAMAGED	79.5	3.665	3.664	0.001A	0.00	4.729

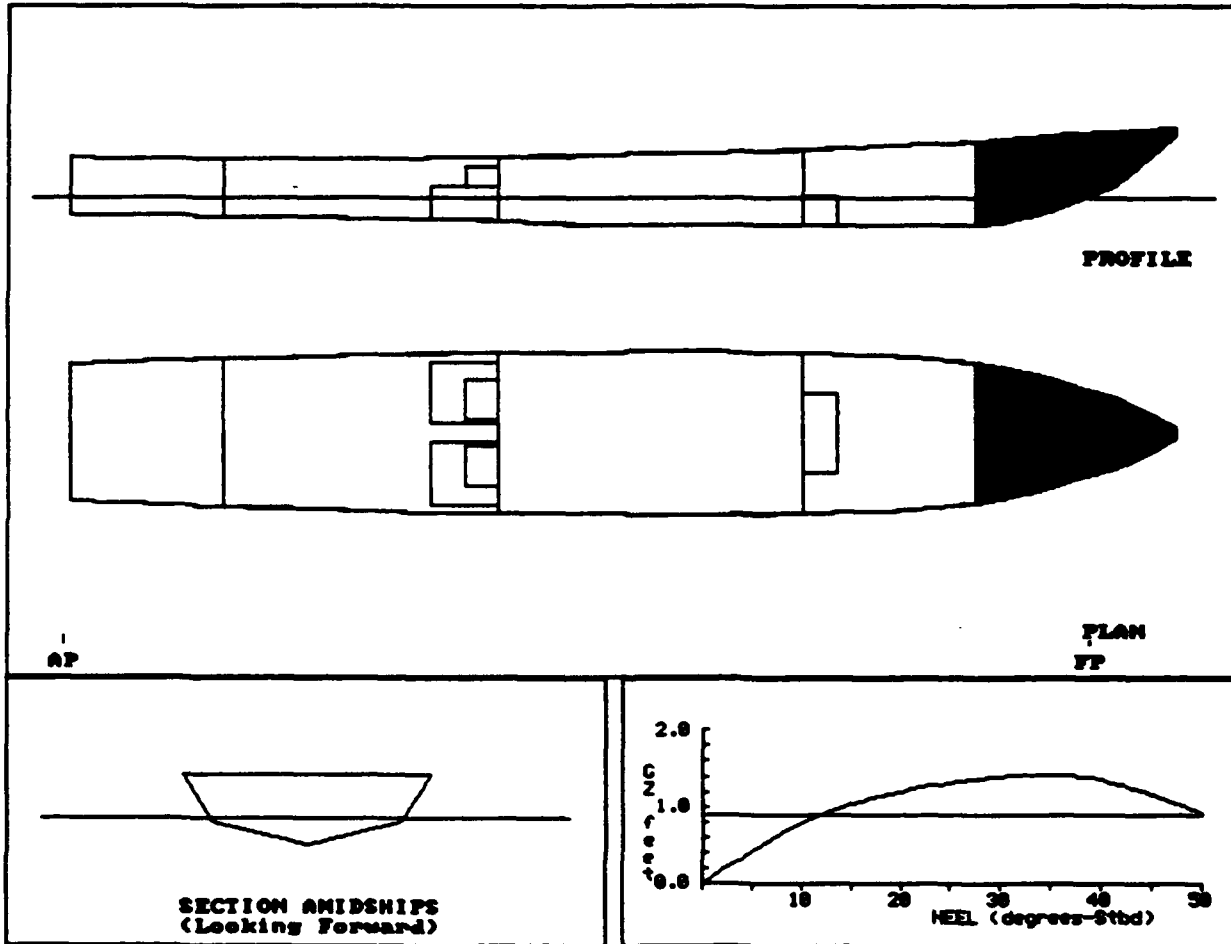

DPRT001A:
 99' CREW BOAT

COMPARTMENT FLOODING SUMMARY

At 0.0o Heel	PERM.	FLOODED WTR LTons	% FULL (Damaged)	% FULL (Intact)	SP.VOL. ft3/LT	OUTFLOW LTons
FOREPEAK	0.95	1.3	FREE	0.0	----	----
Totals		1.3				

INTACT DATA

Draft at AP = 3.750 ft	KMT = 13.299 ft	LCG = 53.454A ft-FP
Draft at FP = 3.470 ft	VCG = 8.630 ft	LCB = 53.473A ft-FP
Displacement = 78.3 LTons	GMT = 4.669 ft	TCG = 0.000 ft-CL

DRAFT/GZ DATA

HEEL degrees	RIGHTING ARM ft	DRAFT AFT ft	DRAFT FWD ft	FLOODED WATER LTons
0.00	0.000	3.665	3.664	1.3
5.00S	0.409	3.671	3.623	1.2
10.00S	0.783	3.652	3.529	1.2
20.00S	1.202	3.411	3.132	0.9
30.00S	1.398	2.784	2.508	0.6
40.00S	1.353	1.801	1.507	0.2
50.00S	0.917	0.545	0.023	0.0

Note: Drafts are measured at A.P. and F.P along ship's centerline

GZ SUMMARY (Evaluated per IMO (SOLAS'90) Rules for Passenger Ships)

	Available	Required
Static Heel Angle	0.00 deg	7.00 deg
Angle at Maximum GZ	35.00S deg	
Maximum GZ	1.425 ft	0.880 ft
Range of Positive GZ	50.00 deg	15.00 deg
Gmt (upright damaged)	4.729 ft	
Righting Area (0.00-7.00)	16.727 ft-deg	2.820 ft-deg

DPRT002A:
 99' CREW BOAT

Imaged Compartments:
 COMPT 2

	DISPLACEMENT LTons	DRAFT AFT ft	DRAFT FWD ft	TRIM ft	HEEL deg.	UPRIGHT GMT ft
INTACT	78.3	3.750	3.470	0.280A	0.00	4.669
DAMAGED	86.7	3.377	4.477	1.100F	0.00	4.518

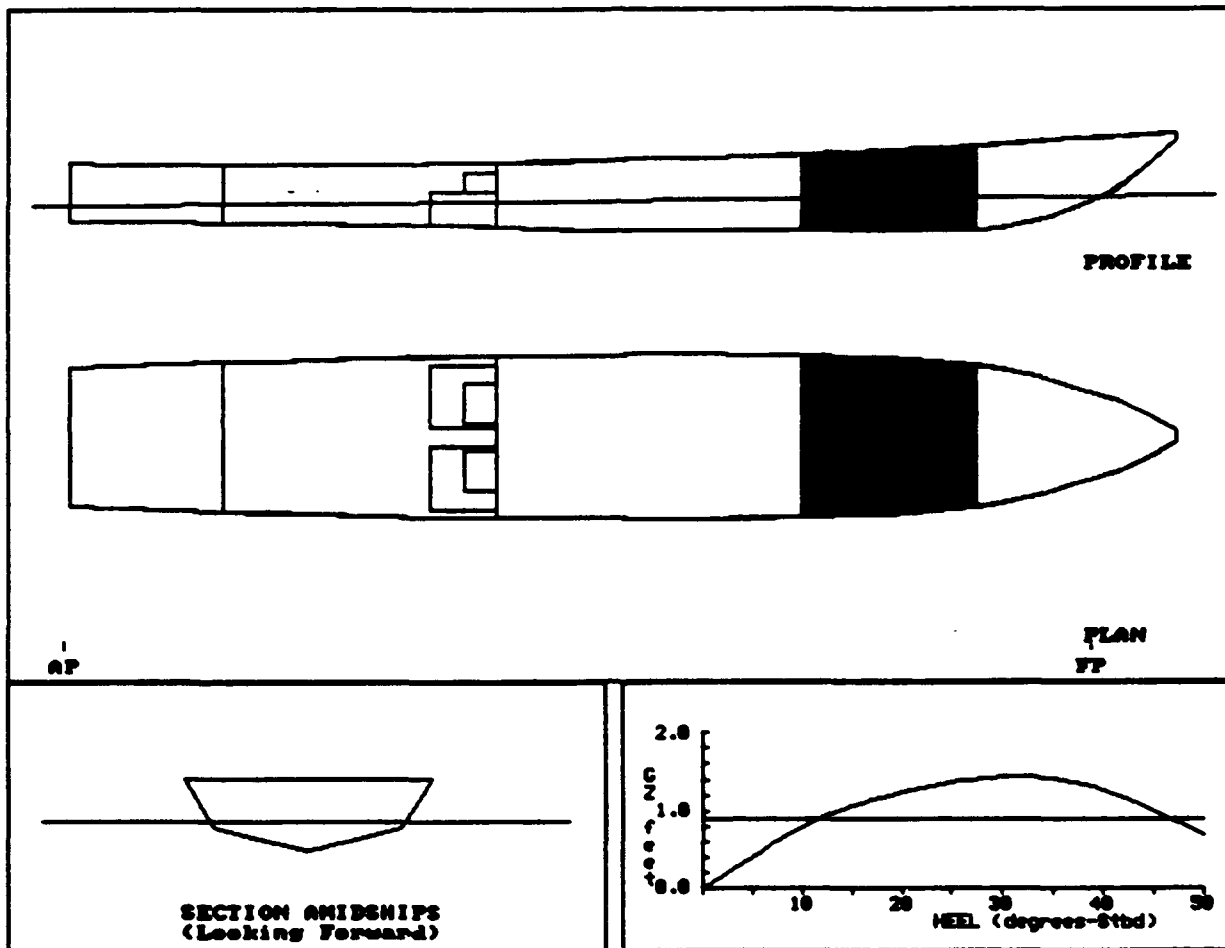

DPRT002A:
 99' CREW BOAT

COMPARTMENT FLOODING SUMMARY

At 0.0o Heel	PERM.	FLOODED WTR LTons	% FULL (Damaged)	% FULL (Intact)	SP.VOL. ft3/LT	OUTFLOW LTons
COMPT 2	0.95	8.4	FREE	0.0	----	----
Totals		8.4				

INTACT DATA

Draft at AP = 3.750 ft	KMt = 13.299 ft	LCG = 53.454A ft-FP
Draft at FP = 3.470 ft	VCG = 8.630 ft	LCB = 53.473A ft-FP
Displacement = 78.3 LTons	GMT = 4.669 ft	TCG = 0.000 ft-CL

DRAFT/GZ DATA

HEEL degrees	RIGHTING ARM ft	DRAFT AFT ft	DRAFT FWD ft	FLOODED WATER LTons
0.00	0.000	3.377	4.477	8.4
5.00S	0.398	3.377	4.453	8.4
10.00S	0.788	3.347	4.403	8.6
20.00S	1.227	3.051	4.137	8.9
30.00S	1.431	2.364	3.644	9.2
40.00S	1.268	1.237	3.030	10.5
50.00S	0.684	-0.307	2.272	11.9

Note: Drafts are measured at A.P. and F.P along ship's centerline

GZ SUMMARY (Evaluated per IMO (SOLAS'90) Rules for Passenger Ships)

	Available	Required
Static Heel Angle	0.00 deg	7.00 deg
Angle at Maximum GZ	33.00S deg	
Maximum GZ	1.435 ft	0.880 ft
Range of Positive GZ	50.00 deg	15.00 deg
Gmt (upright/damaged)	4.518 ft	
Righting Area (0.00-3.00)	16.886 ft-deg	2.820 ft-deg

DPRT003A:
 99' CREW BOAT

Damaged Compartments:
 COMPT 3

	DISPLACEMENT LTons	DRAFT AFT ft	DRAFT FWD ft	TRIM ft	HEEL deg.	UPRIGHT GMT ft
INTACT	78.3	3.750	3.470	0.280A	0.00	4.669
DAMAGED	121.3	3.858	5.835	1.977F	0.00	2.597

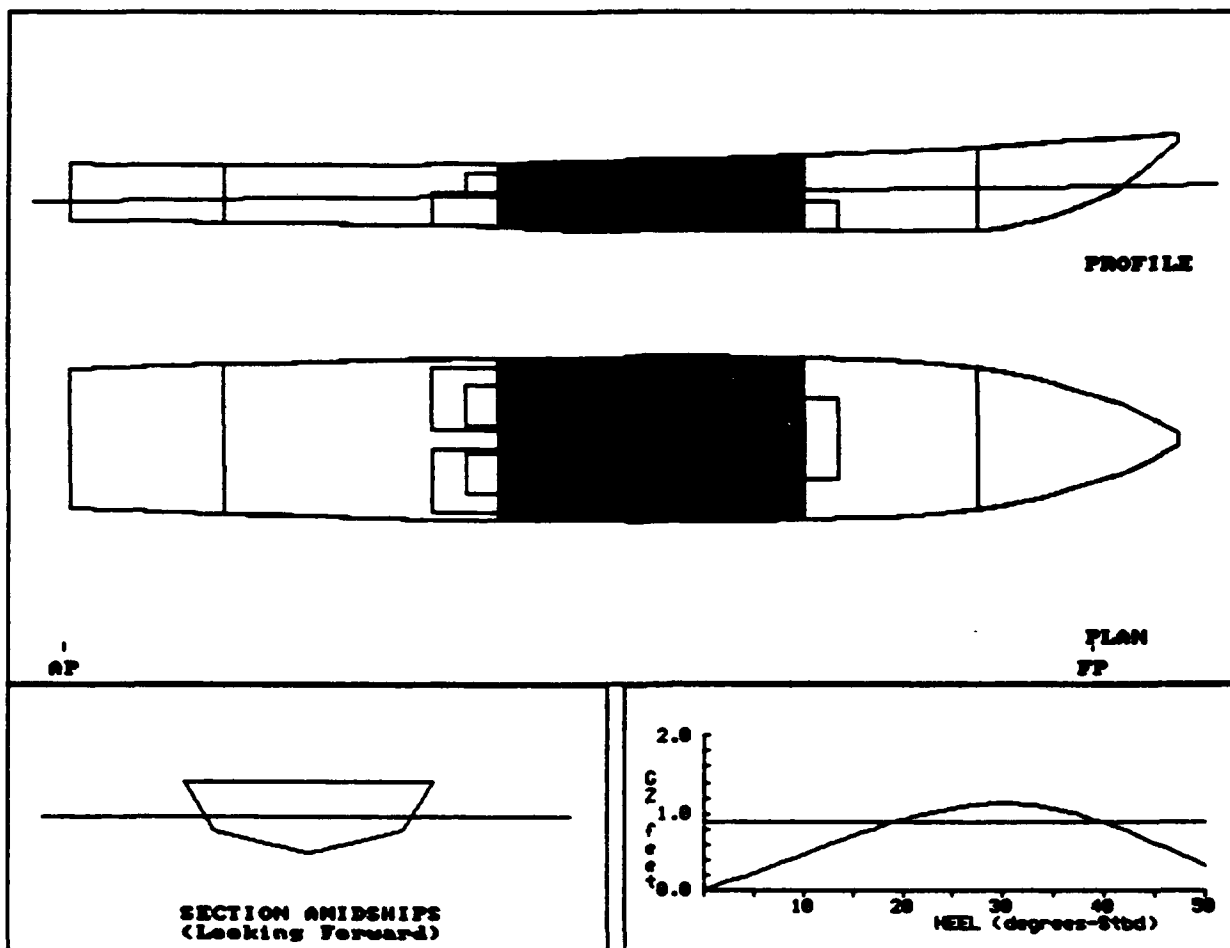

DPR003A:
 99' CREW BOAT

COMPARTMENT FLOODING SUMMARY

At 0.0o Heel	PERM.	FLOODED WTR LTons	% FULL (Damaged)	% FULL (Intact)	SP.VOL. ft3/LT	OUTFLOW LTons
COMPT 3	0.95	43.0	FREE	0.0	----	----
Totals		43.0				

INTACT DATA

Draft at AP = 3.750 ft KMT = 13.299 ft LCG = 53.454A ft-FP
 Draft at FP = 3.470 ft VCG = 8.630 ft LCB = 53.473A ft-FP
 Displacement = 78.3 LTons GMT = 4.669 ft TCG = 0.000 ft-CL

DRAFT/GZ DATA

HEEL degrees	RIGHTING ARM ft	DRAFT AFT ft	DRAFT FWD ft	FLOODED WATER LTons
0.00	0.000	3.858	5.835	43.0
5.00S	0.229	3.852	5.817	43.0
10.00S	0.476	3.839	5.755	43.0
20.00S	0.922	3.669	5.510	43.3
30.00S	1.131	3.185	5.031	43.5
40.00S	0.884	2.561	4.387	42.5
50.00S	0.330	1.762	3.522	41.4

Note: Drafts are measured at A.P. and F.P along ship's centerline

GZ SUMMARY (Evaluated per IMO (SOLAS'90) Rules for Passenger Ships)
 Available Required

Static Heel Angle	0.00 deg	7.00 deg
Angle at Maximum GZ	31.00S deg	
Maximum GZ	1.131 ft	0.880 ft
Range of Positive GZ	50.00 deg	15.00 deg
Gmt (upright damaged)	2.597 ft	
Righting Area (0.00-1.00)	11.334 ft-deg	2.820 ft-deg

DPR004A:
 99' CREW BOAT

Imaged Compartments:
 ENGINE ROOM

	DISPLACEMENT LTons	DRAFT AFT ft	DRAFT FWD ft	TRIM ft	HEEL deg.	UPRIGHT GMT ft
INTACT	78.3	3.750	3.470	0.280A	0.00	4.669
DAMAGED	106.2	5.346	3.038	2.308A	0.00	2.877

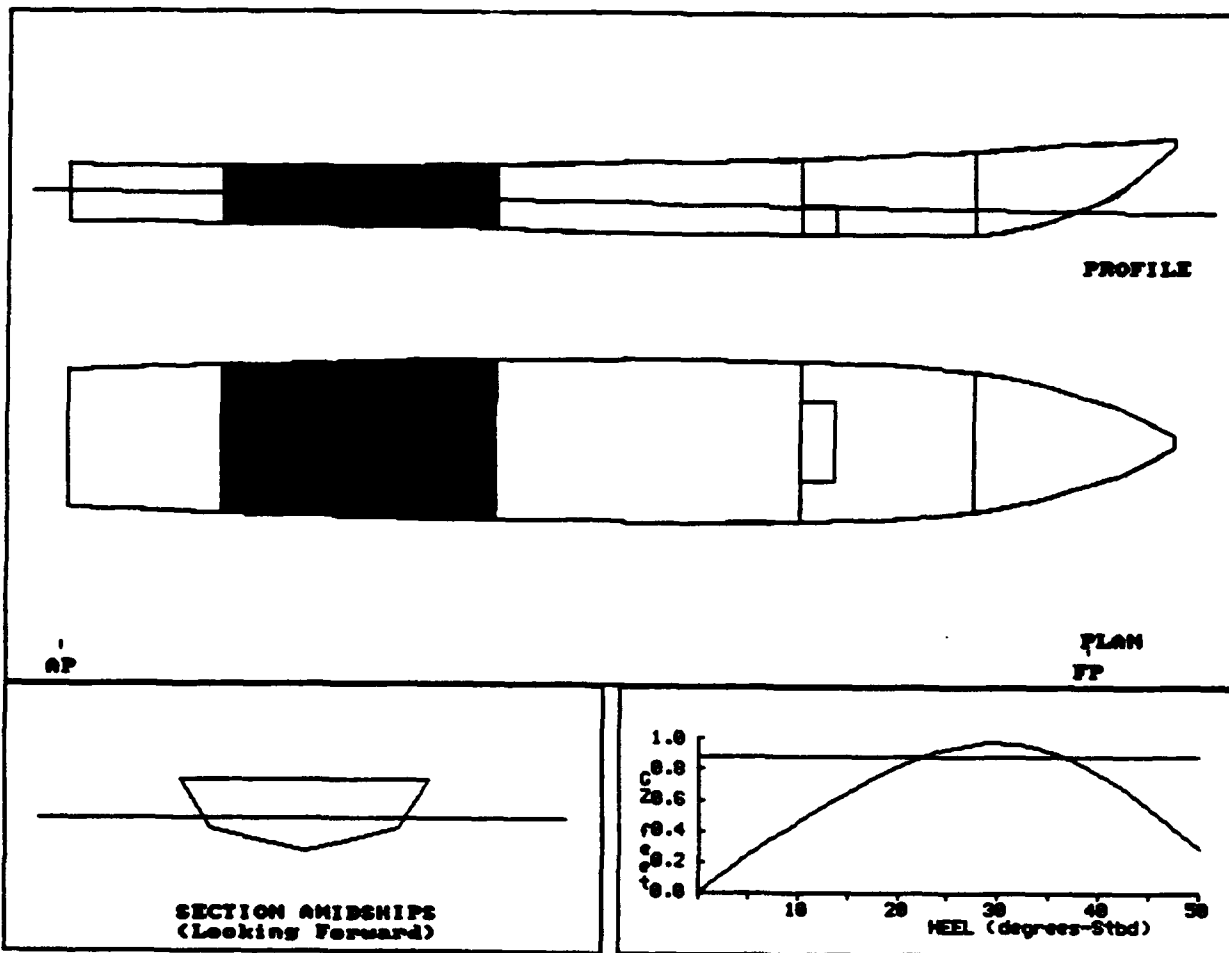

DPRT004A:
 99' CREW BOAT

COMPARTMENT FLOODING SUMMARY

At 0.0o Heel	PERM.	FLOODED WTR LTons	% FULL (Damaged)	% FULL (Intact)	SP.VOL. ft3/LT	OUTFLOW LTons
ENGINE ROOM	0.85	27.9	FREE	0.0	----	----
Totals		27.9				

INTACT DATA

Draft at AP = 3.750 ft	Kmt = 13.299 ft	LCG = 53.454A ft-FP
Draft at FP = 3.470 ft	VCG = 8.630 ft	LCB = 53.473A ft-FP
Displacement = 78.3 LTons	Gmt = 4.669 ft	TCG = 0.000 ft-CL

DRAFT/GZ DATA

HEEL degrees	RIGHTING ARM ft	DRAFT AFT ft	DRAFT FWD ft	FLOODED WATER LTons
0.00	0.000	5.346	3.038	27.9
5.00S	0.242	5.351	3.007	28.0
10.00S	0.454	5.347	2.942	28.4
20.00S	0.813	5.296	2.557	29.3
30.00S	0.975	5.131	1.812	30.1
40.00S	0.772	5.102	0.570	30.3
50.00S	0.283	5.214	-1.292	30.3

Note: Drafts are measured at A.P. and F.P along ship's centerline

GZ SUMMARY (Evaluated per IMO (SOLAS'90) Rules for Passenger Ships)
 Available Required

Static Heel Angle	0.00 deg	7.00 deg
Angle at Maximum GZ	31.00S deg	
Maximum GZ	0.975 ft	0.880 ft
Range of Positive GZ	50.00 deg	15.00 deg
Gmt (upright damaged)	2.877 ft	
Righting Area (0.00-%.00)	10.479 ft-deg	2.820 ft-deg

DPRT005A:
 99' CREW BOAT

Imaged Compartments:
 ENGINE ROOM FO TANK STBD

	DISPLACEMENT LTons	DRAFT AFT ft	DRAFT FWD ft	TRIM ft	HEEL deg.	UPRIGHT GMT ft
INTACT	78.3	3.750	3.470	0.280A	0.00	4.669
DAMAGED	105.9	5.336	3.035	2.301A	0.33P	2.404

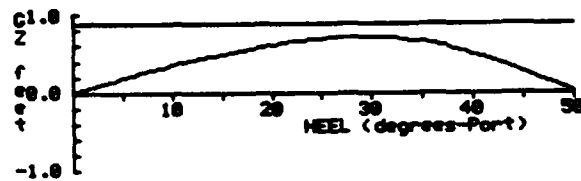
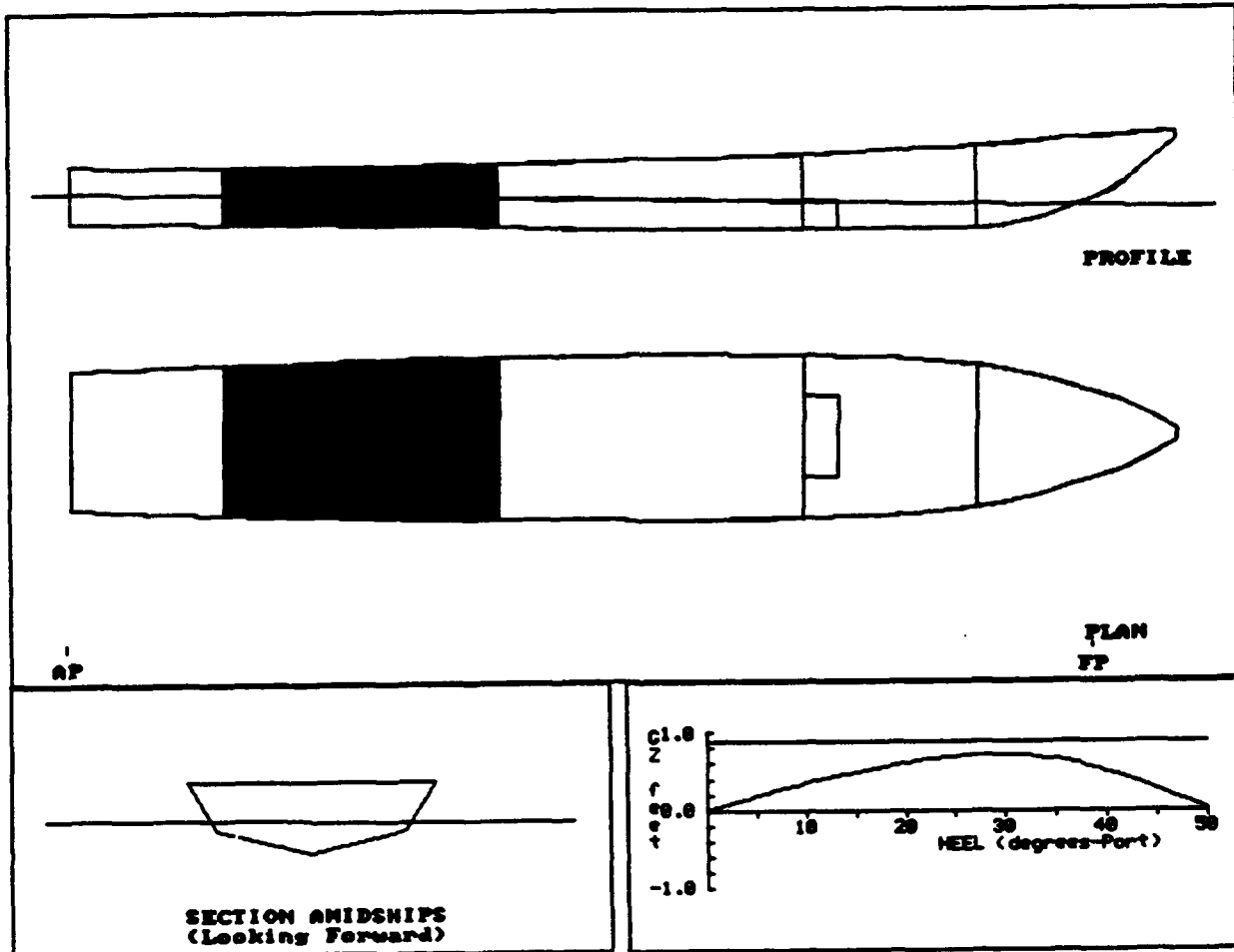

DPRT005A:
 99' CREW BOAT

COMPARTMENT FLOODING SUMMARY

At 0.30P Heel	PERM.	FLOODED WTR LTons	% FULL (Damaged)	% FULL (Intact)	SP.VOL. ft3/LT	OUTFLOW LTons
ENGINE ROOM	0.85	27.8	FREE	0.0	----	----
FO TANK STBD	0.95	3.7	FREE	100.0	40.6000	3.8
Totals		31.5				3.8

INTACT DATA

Draft at AP = 3.750 ft	Kmt = 13.299 ft	LCG = 53.454A ft-FP
Draft at FP = 3.470 ft	VCG = 8.630 ft	LCB = 53.473A ft-FP
Displacement = 78.3 LTons	Gmt = 4.669 ft	TCG = 0.000 ft-CL

DRAFT/GZ DATA

HEEL degrees	RIGHTING ARM ft	DRAFT AFT ft	DRAFT FWD ft	FLOODED WATER LTons
0.00	-0.014	5.339	3.037	31.6
5.00P	0.186	5.299	3.009	30.7
10.00P	0.351	5.271	2.921	30.3
20.00P	0.612	5.154	2.512	29.6
30.00P	0.716	4.871	1.781	29.4
40.00P	0.499	4.681	0.556	28.9
50.00P	0.005	4.578	-1.290	28.7

Note: Drafts are measured at A.P. and F.P along ship's centerline

GZ SUMMARY (Evaluated per IMO (SOLAS'90) Rules for Passenger Ships)
 Available Required

Static Heel Angle	0.33P deg	7.00 deg
Angle at Maximum GZ	30.00P deg	
*** Maximum GZ	0.718 ft	0.880 ft
Range of Positive GZ	49.67 deg	15.00 deg
Righting Area (0.33-4.00)	7.961 ft-deg	2.820 ft-deg

*** indicates failure to meet criterion

DPRTO06A:
99' CREW BOAT

Damaged Compartments:

ENGINE ROOM FO TANK STBD POT H2O STBD

	DISPLACEMENT LTons	DRAFT AFT ft	DRAFT FWD ft	TRIM ft	HEEL deg.	UPRIGHT Gmt ft
INTACT	78.3	3.750	3.470	0.280A	0.00	4.669
DAMAGED	104.1	5.264	3.008	2.256A	2.02P	2.424

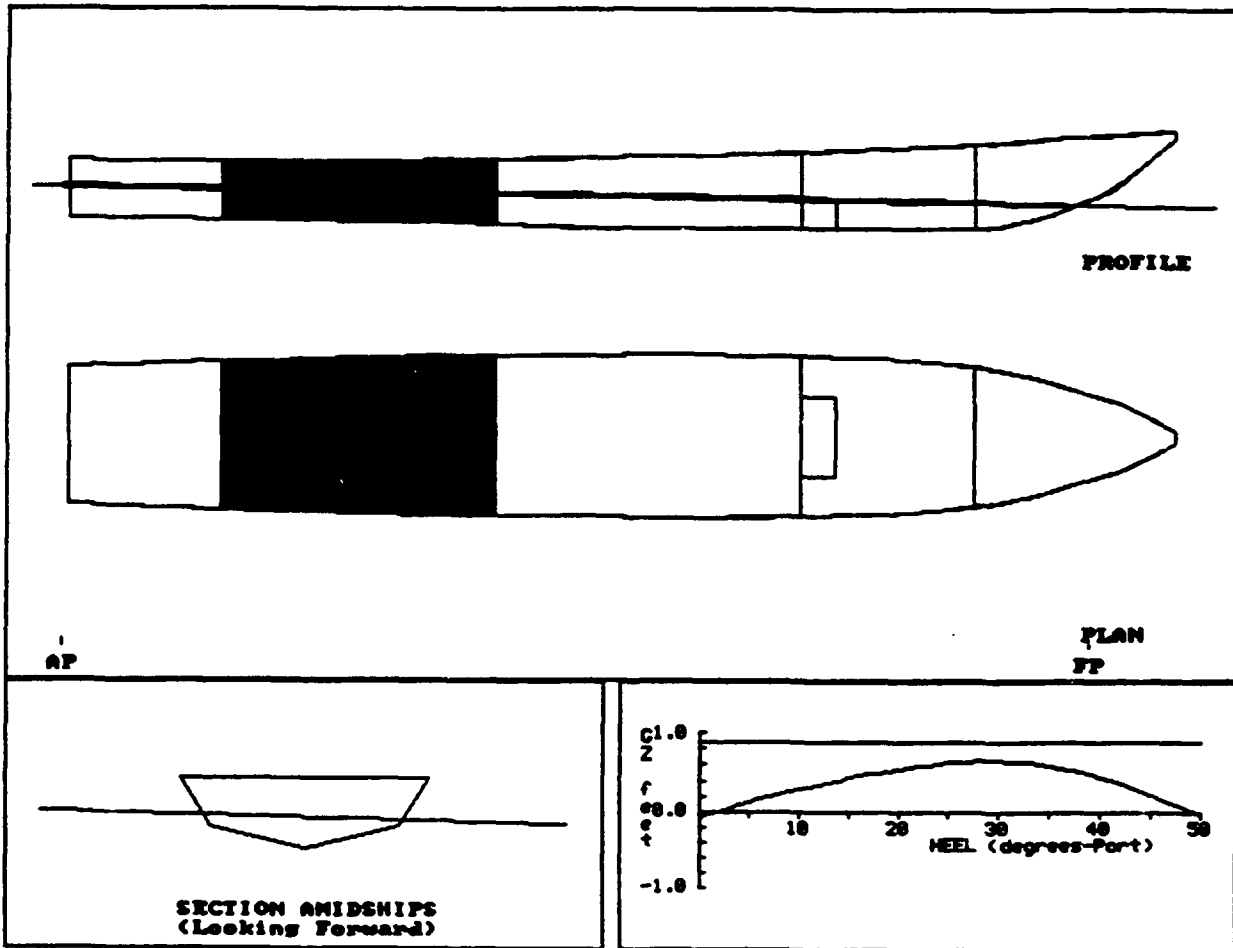

DPRT006A:
 99' CREW BOAT

COMPARTMENT FLOODING SUMMARY

At 2.00P Heel	PERM.	FLOODED WTR LTons	% FULL (Damaged)	% FULL (Intact)	SP.VOL. ft3/LT	OUTFLOW LTons
ENGINE ROOM	0.85	27.3	FREE	0.0	----	----
FO TANK STBD	0.95	3.4	FREE	100.0	40.6000	3.8
POT H2O STBD	0.95	0.0	FREE	100.0	35.8800	1.1
Totals		30.7				5.0

INTACT DATA

Draft at AP = 3.750 ft	KMT = 13.299 ft	LCG = 53.454A ft-FP
Draft at FP = 3.470 ft	VCG = 8.630 ft	LCB = 53.473A ft-FP
Displacement = 78.3 LTons	GMT = 4.669 ft	TCG = 0.000 ft-CL

DRAFT/GZ DATA

HEEL degrees	RIGHTING ARM ft	DRAFT AFT ft	DRAFT FWD ft	FLOODED WATER LTons
0.00	-0.085	5.281	3.018	31.1
5.00P	0.118	5.241	2.988	30.2
10.00P	0.284	5.212	2.898	29.8
20.00P	0.542	5.093	2.487	29.1
30.00P	0.649	4.788	1.763	28.9
40.00P	0.443	4.561	0.543	28.4
50.00P	-0.043	4.406	-1.301	28.2

Note: Drafts are measured at A.P. and F.P along ship's centerline

GZ SUMMARY (Evaluated per IMO (SOLAS'90) Rules for Passenger Ships)
 Available Required

Static Heel Angle	2.02P deg	7.00 deg
Angle at Maximum GZ	30.00P deg	
*** Maximum GZ	0.651 ft	0.880 ft
Range of Positive GZ	47.98 deg	15.00 deg
Righting Area (2.02- $\frac{1}{2}$.00)	6.532 ft-deg	2.820 ft-deg

*** indicates failure to meet criterion

DPERT007A:
 99' CREW BOAT

Imaged Compartments:
 ENGINE ROOM POT H2O STBD

	DISPLACEMENT LTons	DRAFT AFT ft	DRAFT FWD ft	TRIM ft	HEEL deg.	UPRIGHT Gmt ft
INTACT	78.3	3.750	3.470	0.280A	0.00	4.669
DAMAGED	104.7	5.293	3.012	2.281A	1.26P	2.903

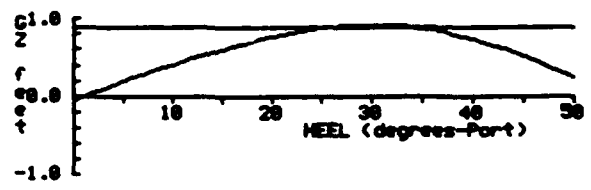
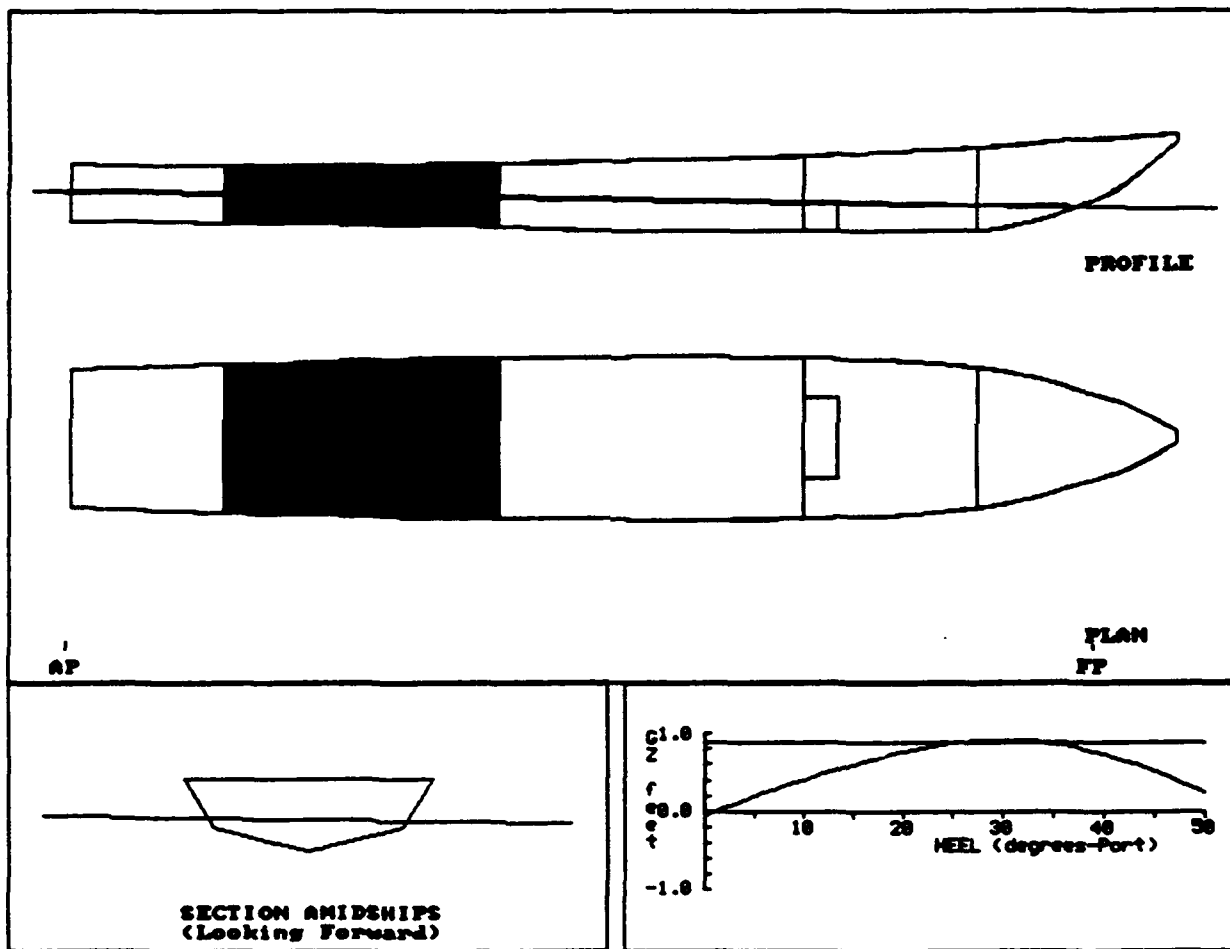

DPRT007A:
 99' CREW BOAT

COMPARTMENT FLOODING SUMMARY

At 1.30P Heel	PERM.	FLOODED WTR LTons	% FULL (Damaged)	% FULL (Intact)	SP.VOL. ft3/LT	OUTFLOW LTons
ENGINE ROOM	0.85	27.5	FREE	0.0	----	----
POT H2O STBD	0.95	0.0	FREE	100.0	35.8800	1.1
Totals		27.5				1.1

INTACT DATA

Draft at AP = 3.750 ft	Kmt = 13.299 ft	LCG = 53.454A ft-FP
Draft at FP = 3.470 ft	VCG = 8.630 ft	LCB = 53.473A ft-FP
Displacement = 78.3 LTons	Gmt = 4.669 ft	TCG = 0.000 ft-CL

DRAFT/GZ DATA

HEEL degrees	RIGHTING ARM ft	DRAFT AFT ft	DRAFT FWD ft	FLOODED WATER LTons
0.00	-0.064	5.291	3.020	27.5
5.00P	0.182	5.297	2.987	27.6
10.00P	0.396	5.292	2.921	28.0
20.00P	0.753	5.237	2.533	28.9
30.00P	0.919	5.048	1.796	29.7
40.00P	0.727	4.983	0.559	29.8
50.00P	0.245	5.042	-1.302	29.8

Note: Drafts are measured at A.P. and F.P. along ship's centerline

GZ SUMMARY (Evaluated per IMO (SOLAS'90) Rules for Passenger Ships)

	Available	Required
Static Heel Angle	1.26P deg	7.00 deg
Angle at Maximum GZ	31.00P deg	
Maximum GZ	0.919 ft	0.880 ft
Range of Positive GZ	48.74 deg	15.00 deg
Righting Area (1.26-%.00)	9.201 ft-deg	2.820 ft-deg

DPRT008A:
 99' CREW BOAT

aged Compartments:
 LAZARETTE

	DISPLACEMENT LTons	DRAFT AFT ft	DRAFT FWD ft	TRIM ft	HEEL deg.	UPRIGHT Gmt ft
INTACT	78.3	3.750	3.470	0.280A	0.00	4.669
DAMAGED	105.5	6.287	1.636	4.651A	0.00	3.158

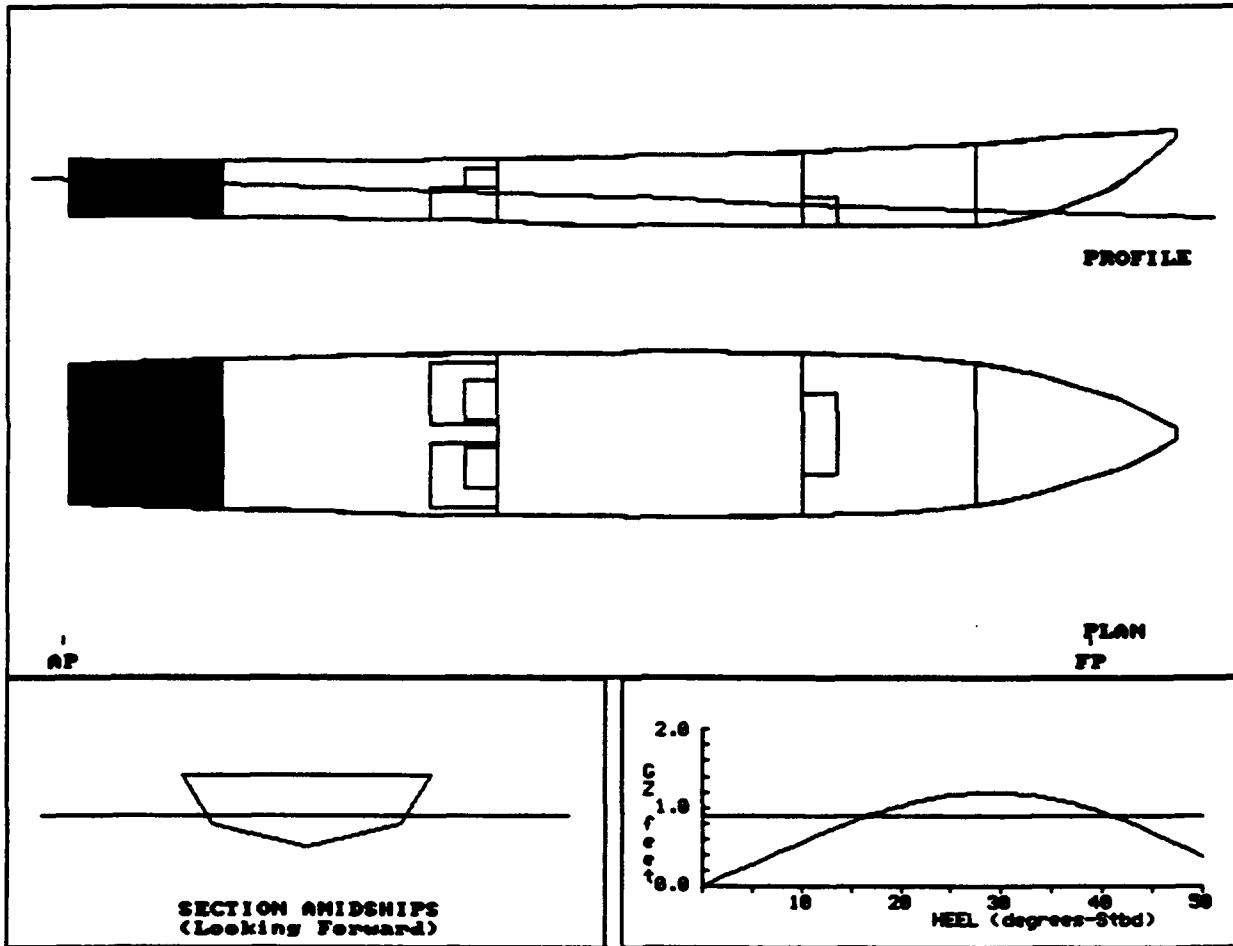

DPRT008A:
 99' CREW BOAT

COMPARTMENT FLOODING SUMMARY

At 0.0o Heel	PERM.	FLOODED WTR LTons	% FULL (Damaged)	% FULL (Intact)	SP.VOL. ft3/LT	OUTFLOW LTons
LAZARETTE	0.95	27.3	FREE	0.0	----	----
Totals		27.3				

INTACT DATA

Draft at AP = 3.750 ft	Kmt = 13.299 ft	LCG = 53.454A ft-FP
Draft at FP = 3.470 ft	VCG = 8.630 ft	LCB = 53.473A ft-FP
Displacement = 78.3 LTons	Gmt = 4.669 ft	TCG = 0.000 ft-CL

DRAFT/GZ DATA

HEEL degrees	RIGHTING ARM ft	DRAFT AFT ft	DRAFT FWD ft	FLOODED WATER LTons
0.00	0.000	6.287	1.636	27.3
5.00S	0.277	6.290	1.597	27.3
10.00S	0.552	6.296	1.479	27.4
20.00S	1.025	6.235	1.013	27.2
30.00S	1.188	6.118	0.137	25.7
40.00S	0.942	6.342	-1.514	25.3
50.00S	0.375	7.046	-4.253	25.6

Note: Drafts are measured at A.P. and F.P along ship's centerline

GZ SUMMARY (Evaluated per IMO (SOLAS'90) Rules for Passenger Ships)
 Available Required

Static Heel Angle	0.00 deg	7.00 deg
Angle at Maximum GZ	30.00S deg	
Maximum GZ	1.189 ft	0.880 ft
Range of Positive GZ	50.00 deg	15.00 deg
Gmt (upright damaged)	3.158 ft	
Righting Area (0.00-%.00)	12.929 ft-deg	2.820 ft-deg

RTRN001A:
 99' CREW BOAT

Damaged Compartments:
 FOREPEAK

	DISPLACEMENT LTons	DRAFT AFT ft	DRAFT FWD ft	TRIM ft	HEEL deg.	UPRIGHT Gmt ft
INTACT	70.8	3.370	3.510	0.140F	0.00	5.018
DAMAGED	72.1	3.284	3.707	0.424F	0.00	5.105

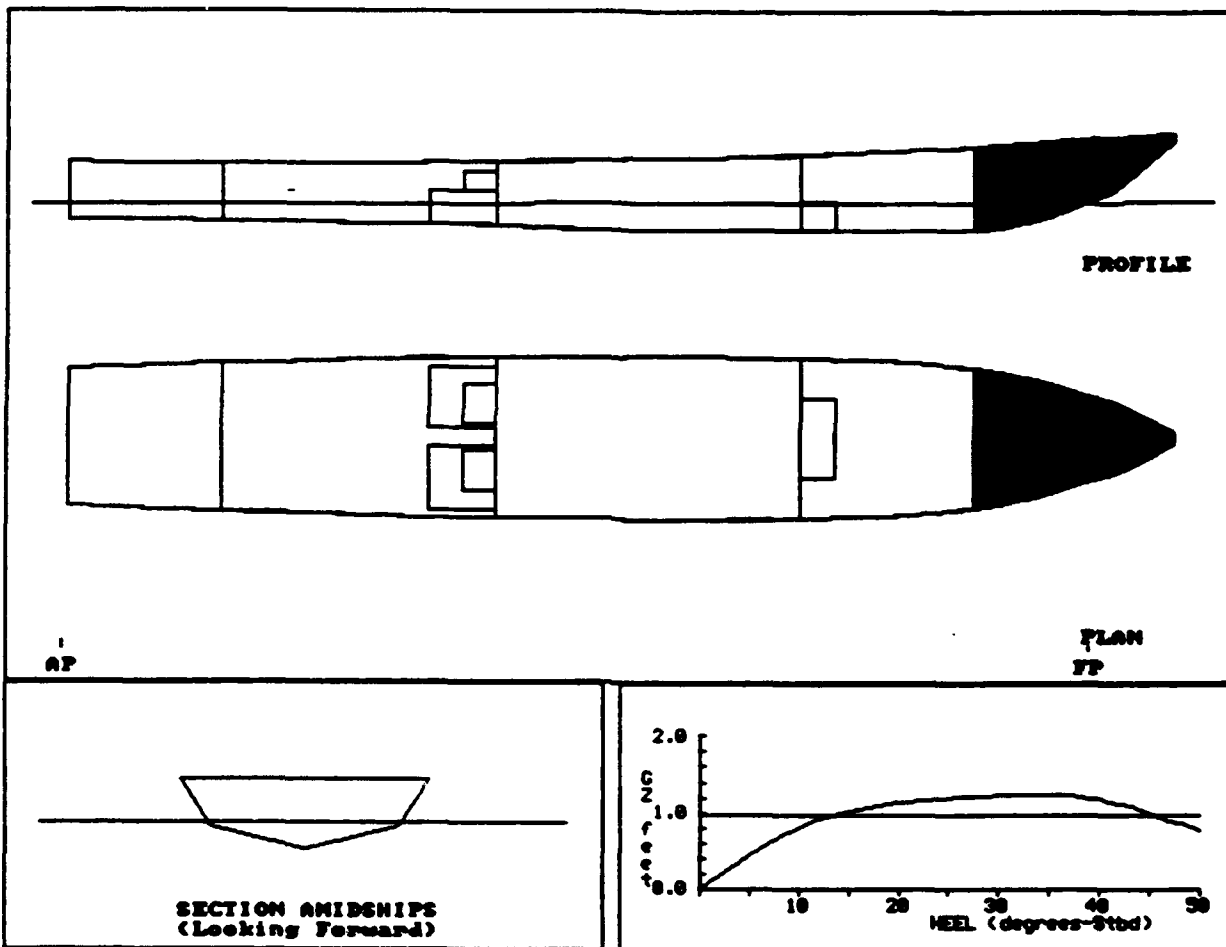

RTRN001A:
 99' CREW BOAT

COMPARTMENT FLOODING SUMMARY

At 0.0o Heel	PERM.	FLOODED WTR LTons	% FULL (Damaged)	% FULL (Intact)	SP.VOL. ft3/LT	OUTFLOW LTons
FOREPEAK	0.95	1.3	FREE	0.0	----	----
Totals		1.3				

INTACT DATA

Draft at AP = 3.370 ft	KMT = 14.028 ft	LCG = 52.442A ft-FP
Draft at FP = 3.510 ft	VCG = 9.010 ft	LCB = 52.432A ft-FP
Displacement = 70.8 LTons	GMT = 5.018 ft	TCG = 0.000 ft-CL

DRAFT/GZ DATA

HEEL degrees	RIGHTING ARM ft	DRAFT AFT ft	DRAFT FWD ft	FLOODED WATER LTons
0.00	0.000	3.284	3.707	1.3
5.00S	0.440	3.290	3.664	1.2
10.00S	0.802	3.255	3.566	1.2
20.00S	1.134	2.945	3.191	1.0
30.00S	1.231	2.232	2.604	0.6
40.00S	1.179	1.058	1.652	0.3
50.00S	0.760	-0.512	0.243	0.0

Note: Drafts are measured at A.P. and F.P along ship's centerline

GZ SUMMARY (Evaluated per IMO (SOLAS'90) Rules for Passenger Ships)

	Available	Required
Static Heel Angle	0.00 deg	7.00 deg
Angle at Maximum GZ	35.00S deg	
Maximum GZ	1.245 ft	0.960 ft
Range of Positive GZ	50.00 deg	15.00 deg
Gmt (upright damaged)	5.105 ft	
Righting Area (0.00- $\frac{1}{2}$.00)	16.591 ft-deg	2.820 ft-deg

RTRN002A:
 99' CREW BOAT

Imaged Compartments:
 COMP 2

	DISPLACEMENT LTons	DRAFT AFT ft	DRAFT FWD ft	TRIM ft	HEEL deg.	UPRIGHT GMT ft
INTACT	70.8	3.370	3.510	0.140F	0.00	5.018
DAMAGED	78.9	3.008	4.488	1.480F	0.00	4.903

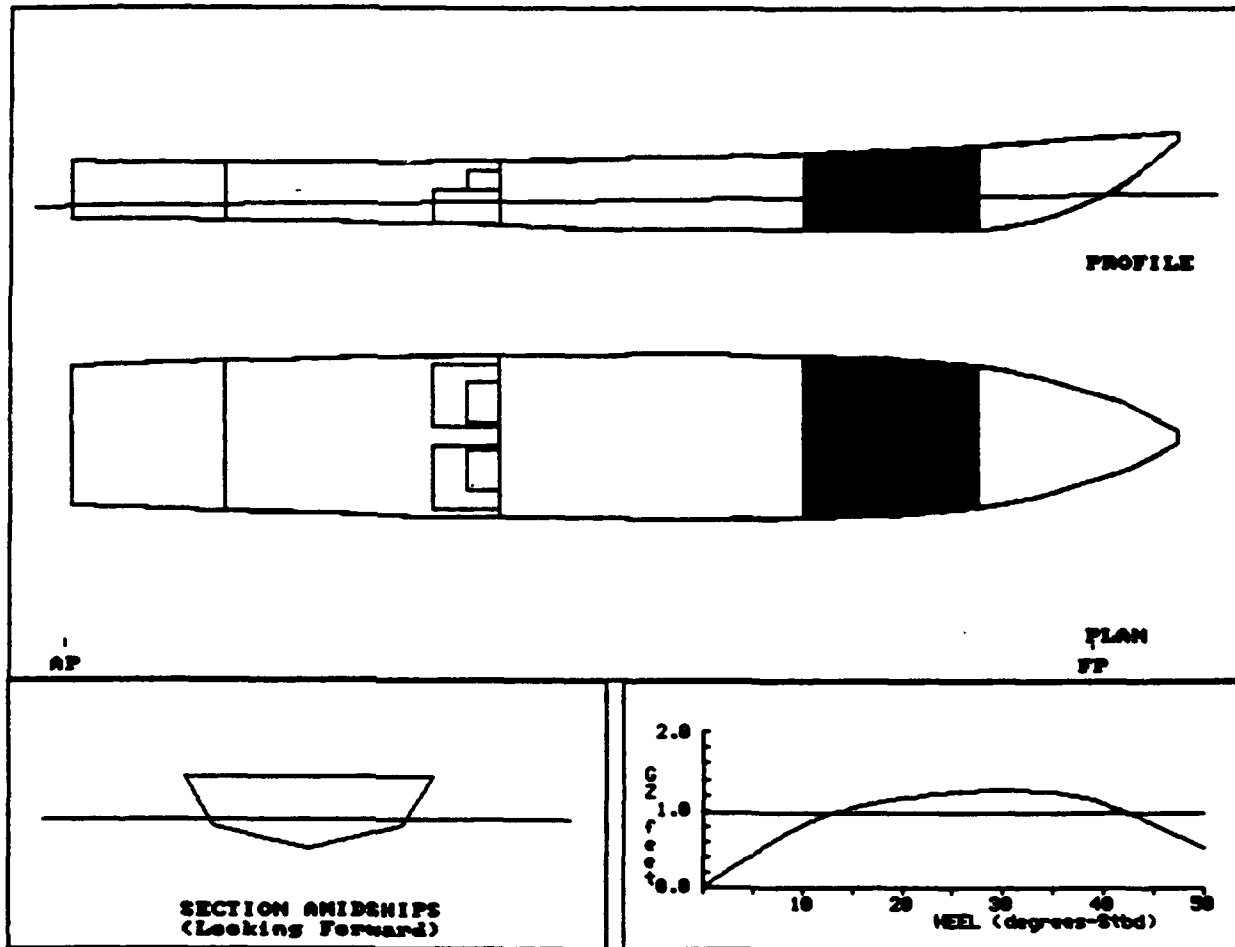

RTRN003A:
 99' CREW BOAT

Imaged Compartments:
 COMPT 3

	DISPLACEMENT LTons	DRAFT AFT ft	DRAFT FWD ft	TRIM ft	HEEL deg.	UPRIGHT Gmt ft
INTACT	70.8	3.370	3.510	0.140F	0.00	5.018
DAMAGED	110.9	3.463	5.751	2.289F	0.00	2.696

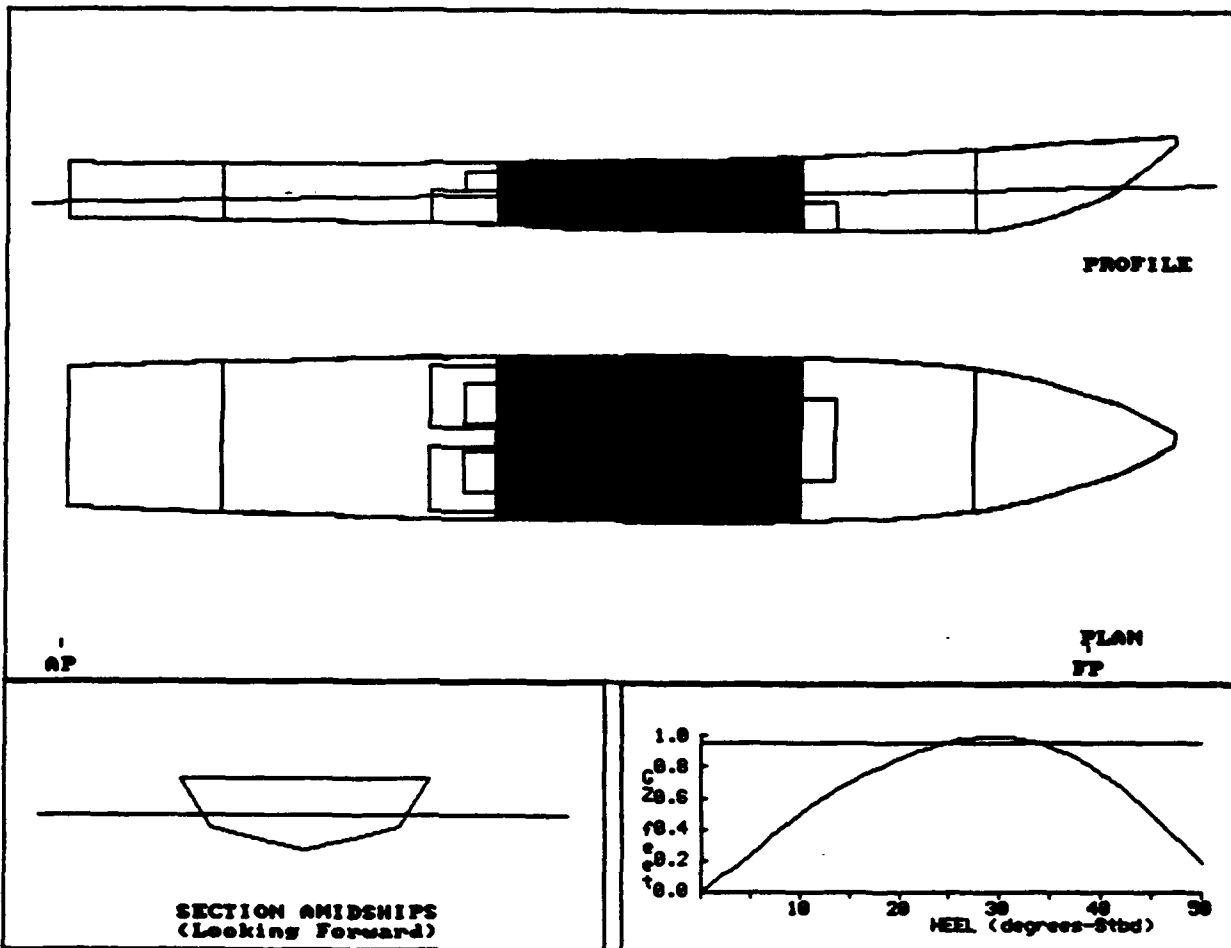

RTRN003A:
 99' CREW BOAT

COMPARTMENT FLOODING SUMMARY

At 0.0o Heel	PERM.	FLOODED WTR LTons	% FULL (Damaged)	% FULL (Intact)	SP.VOL. ft3/LT	OUTFLOW LTons
COMPT 3	0.95	40.1	FREE	0.0	----	----
Totals		40.1				

INTACT DATA

Draft at AP = 3.370 ft Kmt = 14.028 ft LCG = 52.442A ft-FP
 Draft at FP = 3.510 ft VCG = 9.010 ft LCB = 52.432A ft-FP
 Displacement = 70.8 LTons GMT = 5.018 ft TCG = 0.000 ft-CL

DRAFT/GZ DATA

HEEL degrees	RIGHTING ARM ft	DRAFT AFT ft	DRAFT FWD ft	FLOODED WATER LTons
0.00	0.000	3.463	5.751	40.1
5.00S	0.238	3.457	5.732	40.1
10.00S	0.495	3.443	5.672	40.2
20.00S	0.849	3.213	5.438	40.4
30.00S	0.997	2.629	4.969	40.8
40.00S	0.761	1.766	4.336	39.9
50.00S	0.188	0.624	3.480	38.7

Note: Drafts are measured at A.P. and F.P along ship's centerline

GZ SUMMARY (Evaluated per IMO (SOLAS'90) Rules for Passenger Ships)
 Available Required

Static Heel Angle	0.00 deg	7.00 deg
Angle at Maximum GZ	31.00S deg	
Maximum GZ	0.997 ft	0.960 ft
Range of Positive GZ	50.00 deg	15.00 deg
Gmt (upright damaged)	2.696 ft	
Righting Area (0.00-3.00)	11.075 ft-deg	2.820 ft-deg

RTRN004A:
 99' CREW BOAT

Imaged Compartments:
 ENGINE ROOM

	DISPLACEMENT LTons	DRAFT AFT ft	DRAFT FWD ft	TRIM ft	HEEL deg.	UPRIGHT GMT ft
INTACT	70.8	3.370	3.510	0.140F	0.00	5.018
DAMAGED	95.3	4.782	3.134	1.648A	0.00	2.954

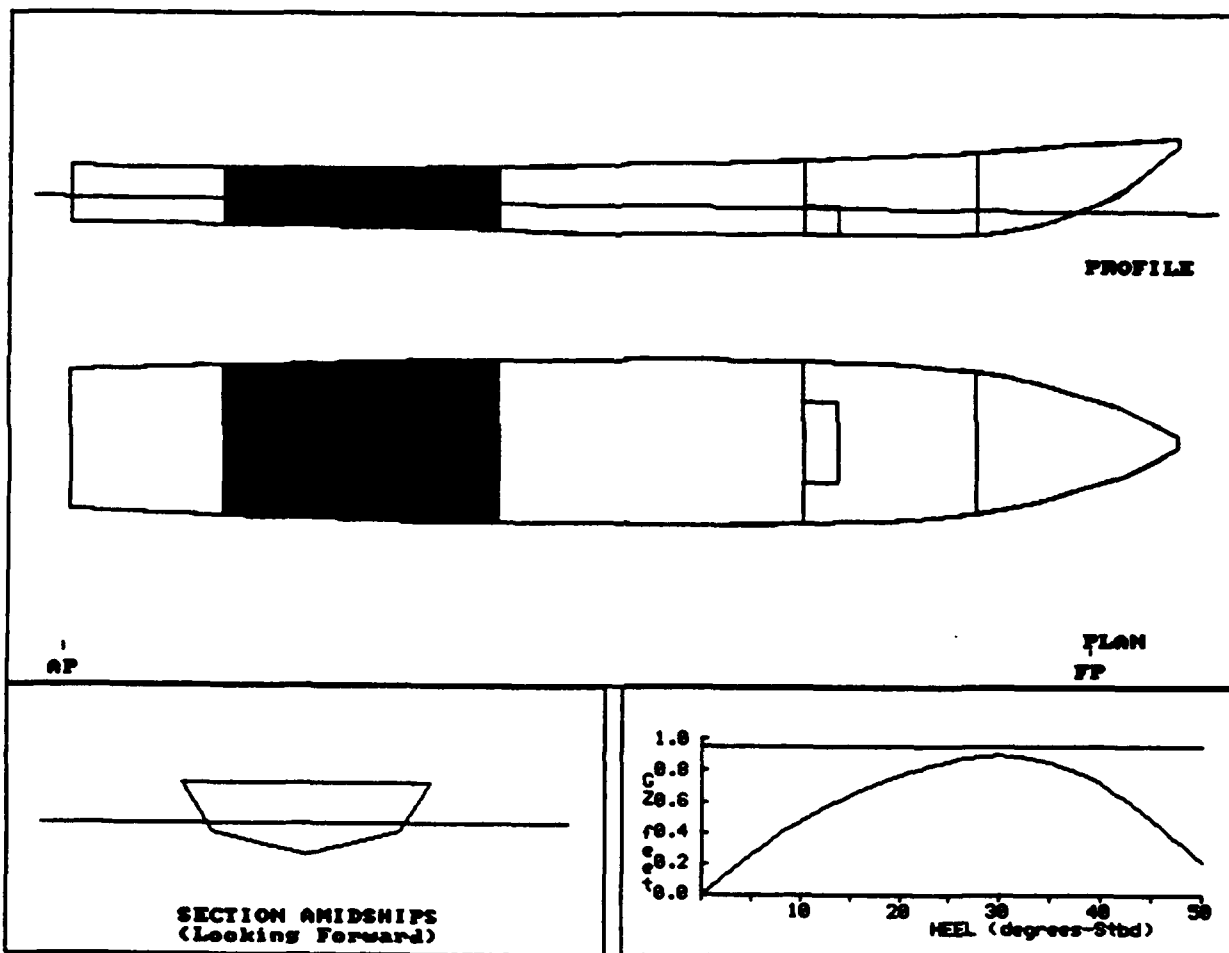

RTRN004A:
 99' CREW BOAT

COMPARTMENT FLOODING SUMMARY

At 0.0o Heel	PERM.	FLOODED WTR LTons	% FULL (Damaged)	% FULL (Intact)	SP.VOL. ft3/LT	OUTFLOW LTons
ENGINE ROOM	0.85	24.5	FREE	0.0	----	----
Totals		24.5				

INTACT DATA

Draft at AP = 3.370 ft	KMt = 14.028 ft	LCG = 52.442A ft-FP
Draft at FP = 3.510 ft	VCG = 9.010 ft	LCB = 52.432A ft-FP
Displacement = 70.8 LTons	Gmt = 5.018 ft	TCG = 0.000 ft-CL

DRAFT/GZ DATA

HEEL degrees	RIGHTING ARM ft	DRAFT AFT ft	DRAFT FWD ft	FLOODED WATER LTons
0.00	0.000	4.782	3.134	24.5
5.00S	0.254	4.787	3.095	24.6
10.00S	0.471	4.775	3.024	24.8
20.00S	0.765	4.690	2.631	25.7
30.00S	0.900	4.321	1.967	26.5
40.00S	0.714	3.952	0.819	26.5
50.00S	0.210	3.559	-0.906	26.4

Note: Drafts are measured at A.P. and F.P along ship's centerline

GZ SUMMARY (Evaluated per IMO (SOLAS'90) Rules for Passenger Ships)
 Available Required

Static Heel Angle	0.00 deg	7.00 deg
Angle at Maximum GZ	31.00S deg	
*** Maximum GZ	0.900 ft	0.960 ft
Range of Positive GZ	50.00 deg	15.00 deg
Gmt (upright damaged)	2.954 ft	
Righting Area (0.00- 1.00)	10.365 ft-deg	2.820 ft-deg

*** indicates failure to meet criterion

RTRN005A:
 99' CREW BOAT

Imaged Compartments:
 ENGINE ROOM FO TANK STBD

	DISPLACEMENT LTons	DRAFT AFT ft	DRAFT FWD ft	TRIM ft	HEEL deg.	UPRIGHT GMT ft
INTACT	70.8	3.370	3.510	0.140F	0.00	5.018
DAMAGED	100.3	4.969	3.162	1.807A	4.90S	2.527

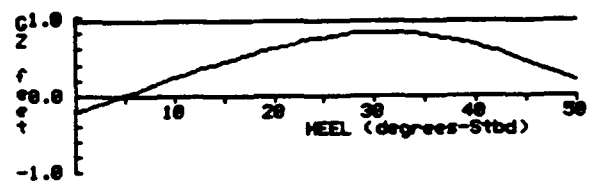
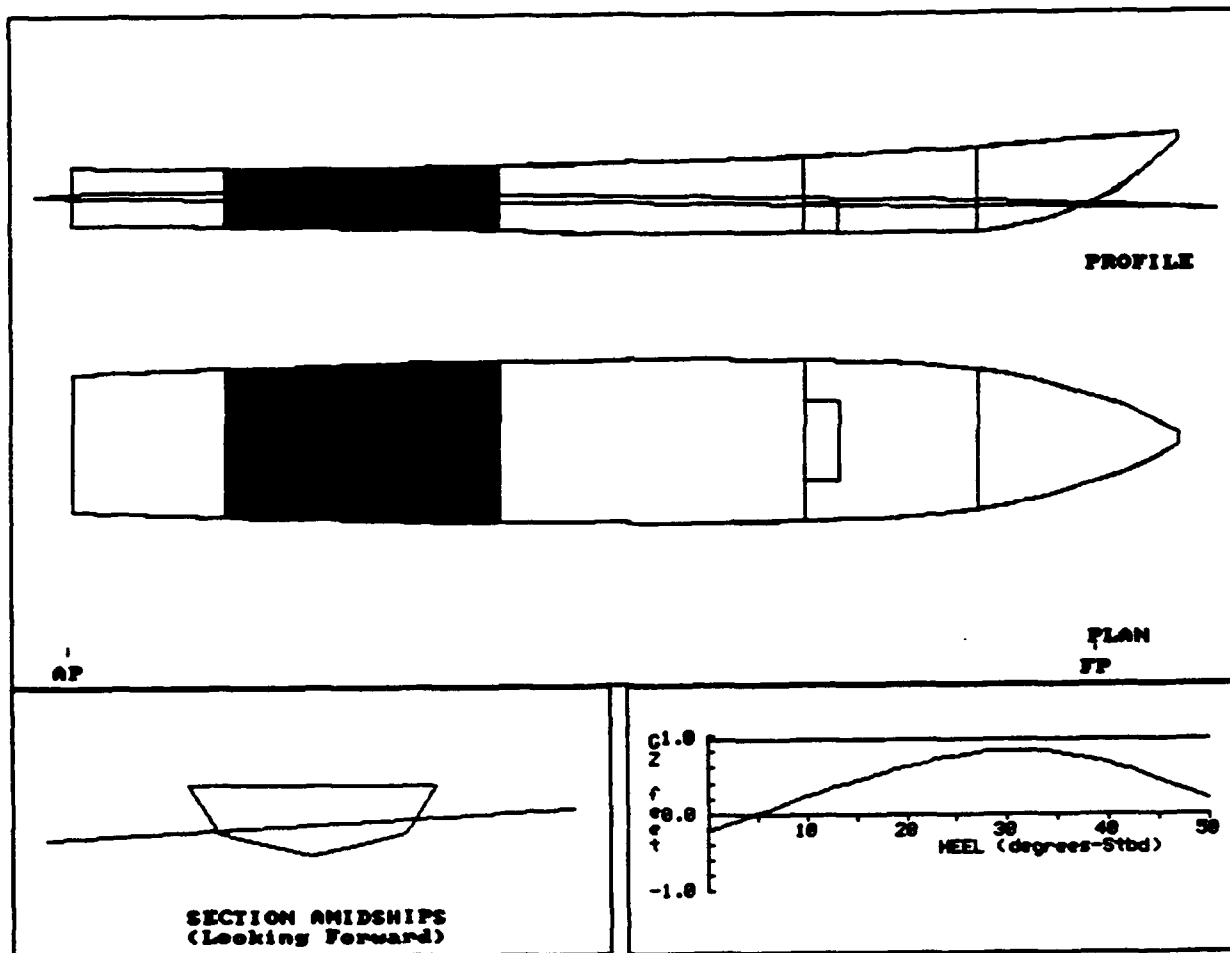

RTRN005A:
 99' CREW BOAT

COMPARTMENT FLOODING SUMMARY

At 4.9oS Heel	PERM.	FLOODED WTR LTons	% FULL (Damaged)	% FULL (Intact)	SP.VOL. ft ³ /LT	OUTFLOW LTons
ENGINE ROOM	0.85	25.9	FREE	0.0	----	----
FO TANK STBD	0.95	4.1	FREE	10.0	40.6000	0.4
Totals		29.9				0.4

INTACT DATA

Draft at AP = 3.370 ft	KMt = 14.028 ft	LCG = 52.442A ft-FP
Draft at FP = 3.510 ft	VCG = 9.010 ft	LCB = 52.432A ft-FP
Displacement = 70.8 LTons	GMT = 5.018 ft	TCG = 0.000 ft-CL

DRAFT/GZ DATA

HEEL degrees	RIGHTING ARM ft	DRAFT AFT ft	DRAFT FWD ft	FLOODED WATER LTons
0.00	-0.214	4.947	3.170	29.1
5.00S	0.005	4.970	3.162	30.0
10.00S	0.230	4.989	3.081	30.7
20.00S	0.610	4.926	2.696	31.7
30.00S	0.816	4.633	2.008	32.5
40.00S	0.656	4.404	0.835	32.5
50.00S	0.179	4.206	-0.906	32.4

Note: Drafts are measured at A.P. and F.P along ship's centerline

GZ SUMMARY (Evaluated per IMO (SOLAS'90) Rules for Passenger Ships)
 Available Required

Static Heel Angle	4.90S deg	7.00 deg
Angle at Maximum GZ	32.00S deg	
*** Maximum GZ	0.818 ft	0.960 ft
Range of Positive GZ	45.10 deg	15.00 deg
Righting Area (4.90-7.00)	6.174 ft-deg	2.820 ft-deg

*** indicates failure to meet criterion

RTRN006A:
 99' CREW BOAT

Damaged Compartments:

ENGINE ROOM FO TANK STBD POT H2O STBD

	DISPLACEMENT LTONS	DRAFT AFT ft	DRAFT FWD ft	TRIM ft	HEEL deg.	UPRIGHT GMT ft
INTACT	70.8	3.370	3.510	0.140F	0.00	5.018
DAMAGED	100.2	4.963	3.161	1.802A	4.74S	2.527

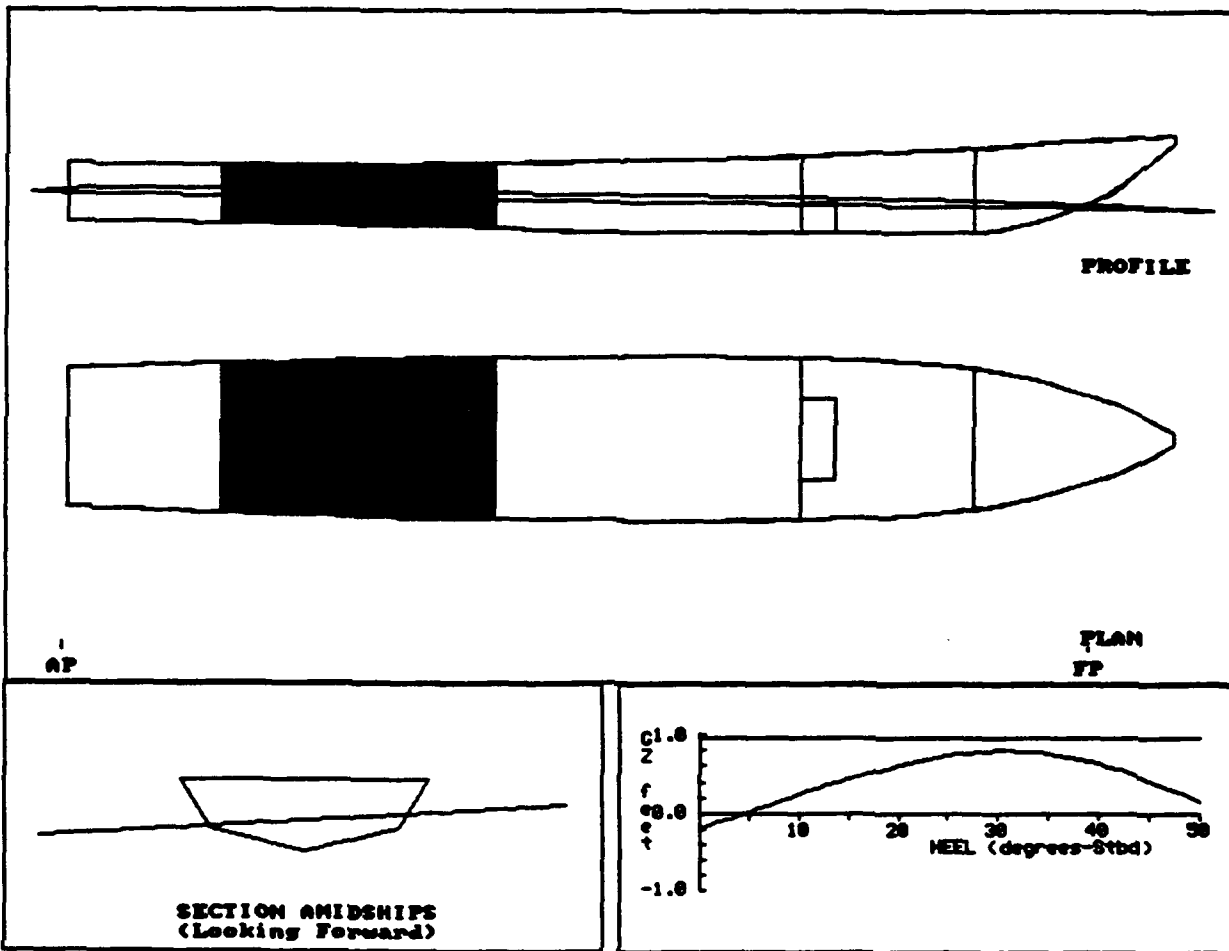

RTRN006A:
 99' CREW BOAT

COMPARTMENT FLOODING SUMMARY

At 4.7oS Heel	PERM.	FLOODED WTR LTons	% FULL (Damaged)	% FULL (Intact)	SP.VOL. ft3/LT	OUTFLOW LTons
ENGINE ROOM	0.85	25.8	FREE	0.0	----	----
FO TANK STBD	0.95	4.1	FREE	10.0	40.6000	0.4
POT H2O STBD	0.95	0.0	FREE	10.0	35.8800	0.1
Totals		29.9				0.5

INTACT DATA

Draft at AP = 3.370 ft	KMt = 14.028 ft	LCG = 52.442A ft-FP
Draft at FP = 3.510 ft	VCG = 9.010 ft	LCB = 52.432A ft-FP
Displacement = 70.8 LTons	GMT = 5.018 ft	TCG = 0.000 ft-CL

DRAFT/GZ DATA

HEEL degrees	RIGHTING ARM ft	DRAFT AFT ft	DRAFT FWD ft	FLOODED WATER LTons
0.00	-0.207	4.942	3.169	29.1
5.00S	0.011	4.964	3.160	29.9
10.00S	0.234	4.985	3.079	30.7
20.00S	0.600	4.933	2.700	32.0
30.00S	0.797	4.659	2.014	33.1
40.00S	0.630	4.461	0.841	33.4
50.00S	0.151	4.307	-0.900	33.5

Note: Drafts are measured at A.P. and F.P along ship's centerline

GZ SUMMARY (Evaluated per IMO (SOLAS'90) Rules for Passenger Ships)
 Available Required

Static Heel Angle	4.74S deg	7.00 deg
Angle at Maximum GZ	32.00S deg	
*** Maximum GZ	0.799 ft	0.960 ft
Range of Positive GZ	45.26 deg	15.00 deg
Righting Area (4.74-%.00)	6.153 ft-deg	2.820 ft-deg

*** indicates failure to meet criterion

RTRN007A:
 99' CREW BOAT

Imaged Compartments:
 ENGINE ROOM POT H2O STBD

	DISPLACEMENT LTons	DRAFT AFT ft	DRAFT FWD ft	TRIM ft	HEEL deg.	UPRIGHT GMT ft
INTACT	70.8	3.370	3.510	0.140F	0.00	5.018
DAMAGED	95.2	4.777	3.131	1.646A	0.13P	2.955

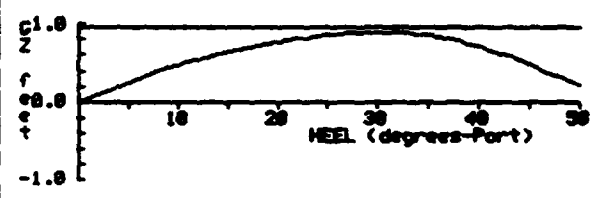
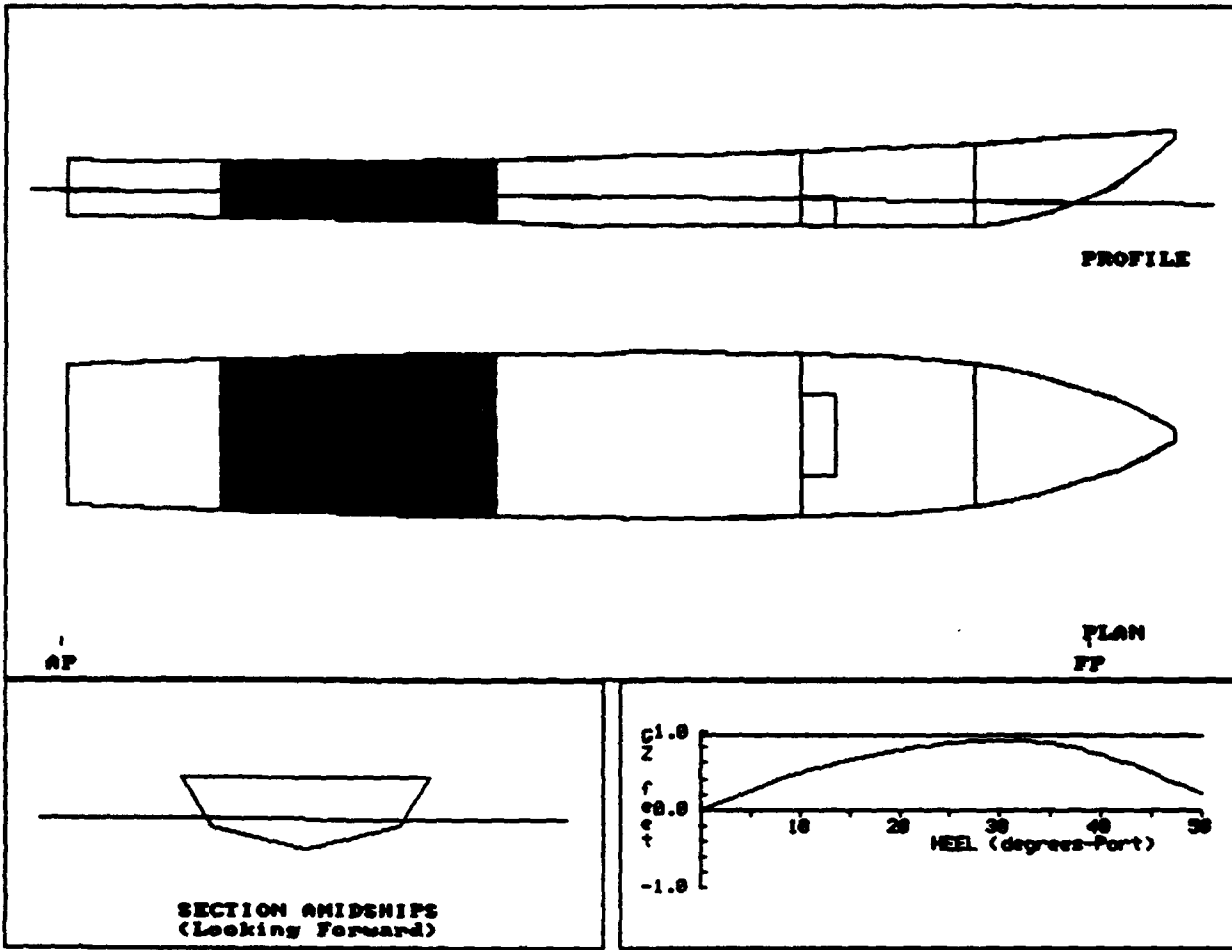

RTRN007A:
 99' CREW BOAT

COMPARTMENT FLOODING SUMMARY

At 0.10P Heel	PERM.	FLOODED WTR LTons	% FULL (Damaged)	% FULL (Intact)	SP.VOL. ft ³ /LT	OUTFLOW LTons
ENGINE ROOM	0.85	24.5	FREE	0.0	----	----
POT H2O STBD	0.95	0.0	FREE	10.0	35.8800	0.1
Totals		24.5				0.1

INTACT DATA

Draft at AP = 3.370 ft	KMT = 14.028 ft	LCG = 52.442A ft-FP
Draft at FP = 3.510 ft	VCG = 9.010 ft	LCB = 52.432A ft-FP
Displacement = 70.8 LTons	GMT = 5.018 ft	TCG = 0.000 ft-CL

DRAFT/GZ DATA

HEEL degrees	RIGHTING ARM ft	DRAFT AFT ft	DRAFT FWD ft	FLOODED WATER LTons
0.00	-0.007	4.776	3.132	24.5
5.00P	0.247	4.782	3.093	24.5
10.00P	0.465	4.769	3.022	24.7
20.00P	0.758	4.684	2.628	25.6
30.00P	0.892	4.313	1.965	26.4
40.00P	0.707	3.940	0.818	26.5
50.00P	0.204	3.542	-0.907	26.4

Note: Drafts are measured at A.P. and F.P along ship's centerline

GZ SUMMARY (Evaluated per IMO (SOLAS'90) Rules for Passenger Ships)

	Available	Required
Static Heel Angle	0.13P deg	7.00 deg
Angle at Maximum GZ	31.00P deg	
*** Maximum GZ	0.892 ft	0.960 ft
Range of Positive GZ	49.87 deg	15.00 deg
Righting Area (0.13-7.00)	10.213 ft-deg	2.820 ft-deg

*** indicates failure to meet criterion

RTRN008A:
 99' CREW BOAT

Imaged Compartments:
 LAZARETTE

	DISPLACEMENT LTons	DRAFT AFT ft	DRAFT FWD ft	TRIM ft	HEEL deg.	UPRIGHT GMT ft
INTACT	70.8	3.370	3.510	0.140F	0.00	5.018
DAMAGED	93.7	5.525	1.964	3.562A	0.00	3.280

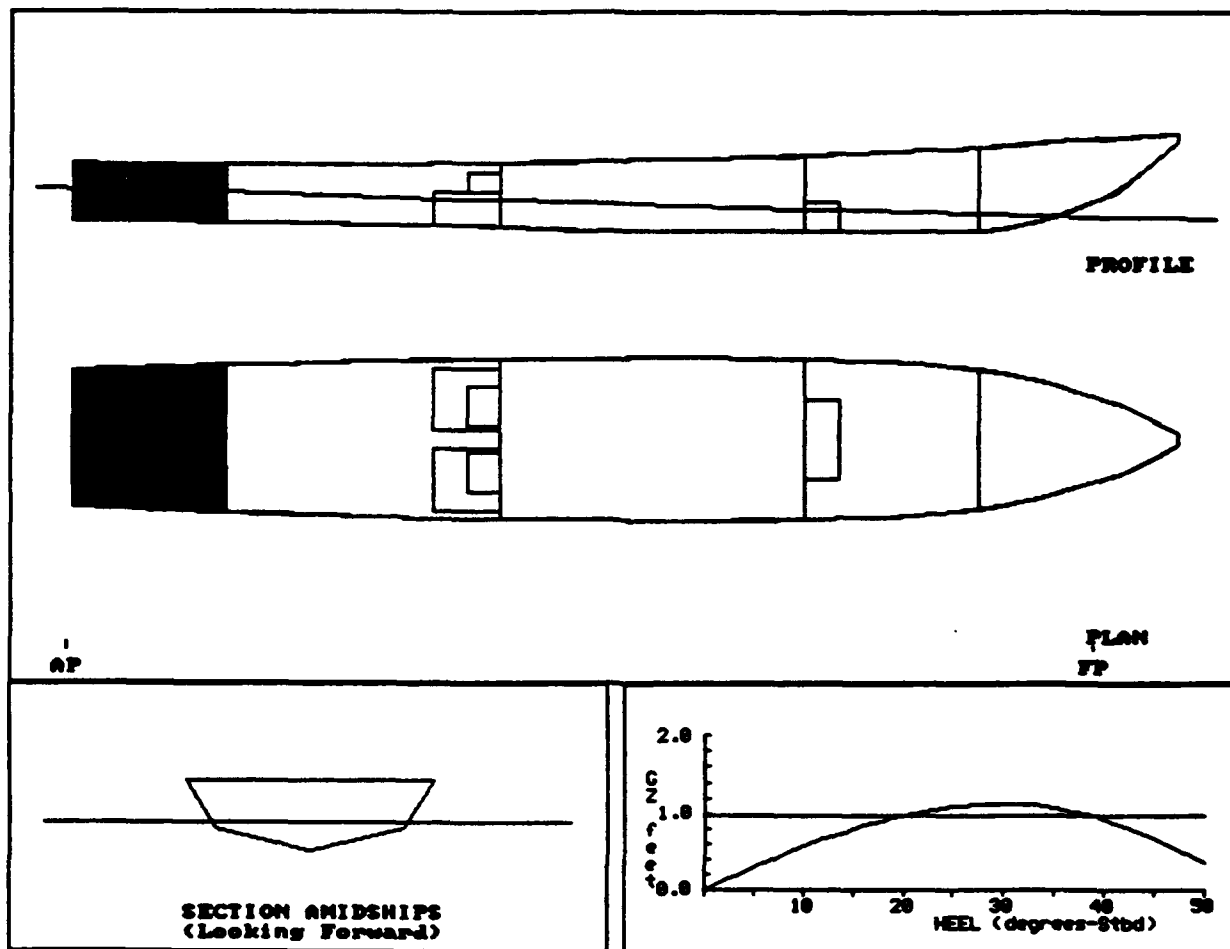

RTRN008A:
 99' CREW BOAT

COMPARTMENT FLOODING SUMMARY

At 0.0o Heel	PERM.	FLOODED WTR LTons	% FULL (Damaged)	% FULL (Intact)	SP.VOL. ft3/LT	OUTFLOW LTons
LAZARETTE	0.95	23.0	FREE	0.0	----	----
Totals		23.0				

INTACT DATA

Draft at AP = 3.370 ft	KMt = 14.028 ft	LCG = 52.442A ft-FP
Draft at FP = 3.510 ft	VCG = 9.010 ft	LCB = 52.432A ft-FP
Displacement = 70.8 LTons	Gmt = 5.018 ft	TCG = 0.000 ft-CL

DRAFT/GZ DATA

HEEL degrees	RIGHTING ARM ft	DRAFT AFT ft	DRAFT FWD ft	FLOODED WATER LTons
0.00	0.000	5.525	1.964	23.0
5.00S	0.287	5.516	1.938	22.9
10.00S	0.561	5.522	1.815	23.0
20.00S	0.965	5.404	1.365	22.7
30.00S	1.122	4.992	0.651	21.3
40.00S	0.920	4.748	-0.752	20.8
50.00S	0.357	4.768	-3.140	21.0

Note: Drafts are measured at A.P. and F.P along ship's centerline

GZ SUMMARY (Evaluated per IMO (SOLAS'90) Rules for Passenger Ships)

	Available	Required
Static Heel Angle	0.00 deg	7.00 deg
Angle at Maximum GZ	31.00S deg	
Maximum GZ	1.122 ft	0.960 ft
Range of Positive GZ	50.00 deg	15.00 deg
Gmt (upright damaged)	3.280 ft	
Righting Area (0.00- $\frac{1}{2}$.00)	12.647 ft-deg	2.820 ft-deg

DPTA001A:
99' CREW BOAT

COMPARTMENT FLOODING SUMMARY

At 0.0o Heel	PERM.	FLOODED WTR LTons	% FULL (Damaged)	% FULL (Intact)	SP.VOL. ft3/LT	OUTFLOW LTons
FOREPEAK	0.95	1.3	FREE	0.0	----	----
Totals		1.3				

INTACT DATA

Draft at AP = 3.750 ft KMT = 13.299 ft LCG = 53.455A ft-FP
 Draft at FP = 3.470 ft VCG = 8.160 ft LCB = 53.473A ft-FP
 Displacement = 78.3 LTons GMT = 5.139 ft TCG = 0.000 ft-CL

DRAFT/GZ DATA

HEEL degrees	RIGHTING ARM ft	DRAFT AFT ft	DRAFT FWD ft	FLOODED WATER LTons
0.00	0.000	3.665	3.664	1.3
5.00S	0.450	3.672	3.622	1.2
10.00S	0.865	3.652	3.529	1.2
20.00S	1.362	3.410	3.133	0.9
30.00S	1.633	2.784	2.508	0.6
40.00S	1.655	1.801	1.507	0.2
50.00S	1.277	0.546	0.023	0.0

Note: Drafts are measured at A.P. and F.P along ship's centerline

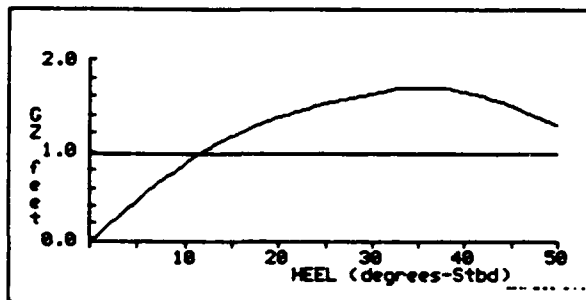

Static Heel = 0.0 deg
 Draft at AP = 3.665 ft
 Draft at FP = 3.664 ft

Gmt (upright damaged) = 5.198 ft
 Angle at Maximum GZ = 37.00S deg
 Maximum GZ = 1.695 ft
 Range of Positive GZ = 58.00 deg

Area to 22.0 degrees = 18.69 ft-deg

DPTA002A:
 99' CREW BOAT

COMPARTMENT FLOODING SUMMARY

At 0.0o Heel	PERM.	FLOODED WTR LTons	% FULL (Damaged)	% FULL (Intact)	SP.VOL. ft3/LT	OUTFLOW LTons
COMPT 2	0.95	8.4	FREE	0.0	----	----
Totals		8.4				

INTACT DATA

Draft at AP = 3.750 ft KMT = 13.299 ft LCG = 53.455A ft-FP
 Draft at FP = 3.470 ft VCG = 8.160 ft LCB = 53.473A ft-FP
 Displacement = 78.3 LTons Gmt = 5.139 ft TCG = 0.000 ft-CL

DRAFT/GZ DATA

HEEL degrees	RIGHTING ARM ft	DRAFT AFT ft	DRAFT FWD ft	FLOODED WATER LTons
0.00	0.000	3.379	4.475	8.4
5.00S	0.439	3.378	4.451	8.4
10.00S	0.870	3.349	4.401	8.6
20.00S	1.388	3.052	4.135	8.9
30.00S	1.666	2.365	3.642	9.2
40.00S	1.570	1.239	3.028	10.5
50.00S	1.044	-0.304	2.268	11.8

Note: Drafts are measured at A.P. and F.P along ship's centerline

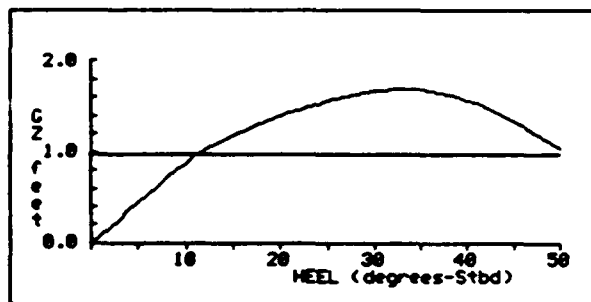

Static Heel = 0.0 deg
 Draft at AP = 3.379 ft
 Draft at FP = 4.475 ft

Gmt (upright damaged) = 4.988 ft
 Angle at Maximum GZ = 34.985 deg
 Maximum GZ = 1.687 ft
 Range of Positive GZ = 50.00 deg

Area to 22.0 degrees = 18.85 ft-deg

DPTA003A:
 99' CREW BOAT

COMPARTMENT FLOODING SUMMARY

At 0.0o Heel	PERM.	FLOODED WTR LTons	% FULL (Damaged)	% FULL (Intact)	SP.VOL. ft3/LT	OUTFLOW LTons
COMPT 3	0.95	43.0	FREE	0.0	----	----
Totals		43.0				

INTACT DATA

Draft at AP = 3.750 ft KMT = 13.299 ft LCG = 53.455A ft-FP
 Draft at FP = 3.470 ft VCG = 8.160 ft LCB = 53.473A ft-FP
 Displacement = 78.3 LTons GMT = 5.139 ft TCG = 0.000 ft-CL

DRAFT/GZ DATA

HEEL degrees	RIGHTING ARM ft	DRAFT AFT ft	DRAFT FWD ft	FLOODED WATER LTons
0.00	0.000	3.860	5.832	43.0
5.00S	0.270	3.854	5.815	43.0
10.00S	0.557	3.841	5.752	43.0
20.00S	1.082	3.671	5.507	43.3
30.00S	1.366	3.186	5.029	43.4
40.00S	1.186	2.563	4.385	42.5
50.00S	0.690	1.763	3.521	41.4

Note: Drafts are measured at A.P. and F.P along ship's centerline

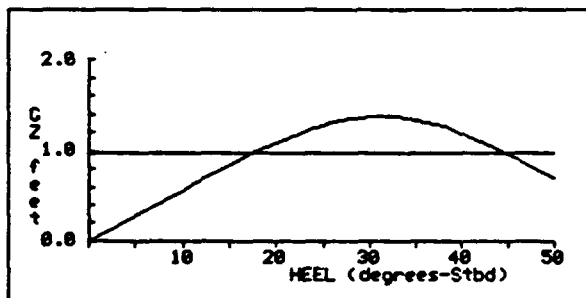

Static Heel = 0.0 deg
 Draft at AP = 3.860 ft
 Draft at FP = 5.832 ft

Gmt (upright damaged) = 3.066 ft
 Angle at Maximum GZ = 32.005 deg
 Maximum GZ = 1.369 ft
 Range of Positive GZ = 50.00 deg

Area to 22.0 degrees = 13.29 ft-deg

DPTA004A:
 99' CREW BOAT

COMPARTMENT FLOODING SUMMARY

At 0.0o Heel	PERM.	FLOODED WTR LTons	% FULL (Damaged)	% FULL (Intact)	SP.VOL. ft3/LT	OUTFLOW LTons
ENGINE ROOM	0.85	27.9	FREE	0.0	----	----
Totals		27.9				

INTACT DATA

Draft at AP = 3.750 ft KMT = 13.299 ft LCG = 53.455A ft-FP
 Draft at FP = 3.470 ft VCG = 8.160 ft LCB = 53.473A ft-FP
 Displacement = 78.3 LTons GMT = 5.139 ft TCG = 0.000 ft-CL

DRAFT/GZ DATA

HEEL degrees	RIGHTING ARM ft	DRAFT AFT ft	DRAFT FWD ft	FLOODED WATER LTons
0.00	0.000	5.344	3.041	27.9
5.00S	0.283	5.349	3.010	28.0
10.00S	0.536	5.345	2.944	28.4
20.00S	0.974	5.293	2.560	29.3
30.00S	1.210	5.127	1.816	30.1
40.00S	1.075	5.097	0.575	30.3
50.00S	0.644	5.207	-1.286	30.3

Note: Drafts are measured at A.P. and F.P along ship's centerline

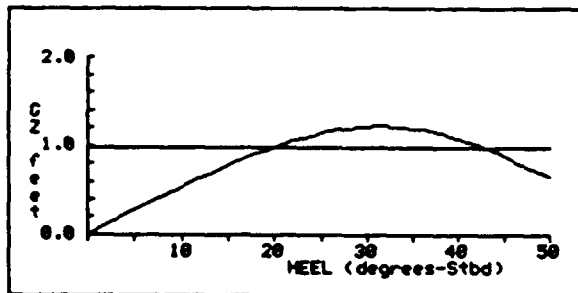

Static Heel = 0.0 deg
 Draft at AP = 5.344 ft
 Draft at FP = 3.041 ft

Gmt (upright damaged) = 3.348 ft
 Angle at Maximum GZ = 33.00S deg
 Maximum GZ = 1.215 ft
 Range of Positive GZ = 50.00 deg

Area to 22.0 degrees = 12.44 ft-deg

DPTA005A:
 99' CREW BOAT

COMPARTMENT FLOODING SUMMARY

At 0.30P Heel	PERM.	FLOODED WTR LTons	% FULL (Damaged)	% FULL (Intact)	SP.VOL. ft ³ /LT	OUTFLOW LTons
ENGINE ROOM	0.85	27.8	FREE	0.0	----	----
FO TANK STBD	0.95	3.7	FREE	100.0	40.6000	3.8
Totals		31.5				3.8

INTACT DATA

Draft at AP = 3.750 ft KMt = 13.299 ft LCG = 53.455A ft-FP
 Draft at FP = 3.470 ft VCG = 8.160 ft LCB = 53.473A ft-FP
 Displacement = 78.3 LTons GMT = 5.139 ft TCG = 0.000 ft-CL

DRAFT/GZ DATA

HEEL degrees	RIGHTING ARM ft	DRAFT AFT ft	DRAFT FWD ft	FLOODED WATER LTons
0.00	-0.014	5.337	3.039	31.6
5.00P	0.229	5.297	3.011	30.7
10.00P	0.437	5.269	2.923	30.3
20.00P	0.782	5.151	2.516	29.6
30.00P	0.964	4.868	1.784	29.4
40.00P	0.817	4.677	0.560	28.9
50.00P	0.385	4.571	-1.284	28.7

Note: Drafts are measured at A.P. and F.P along ship's centerline

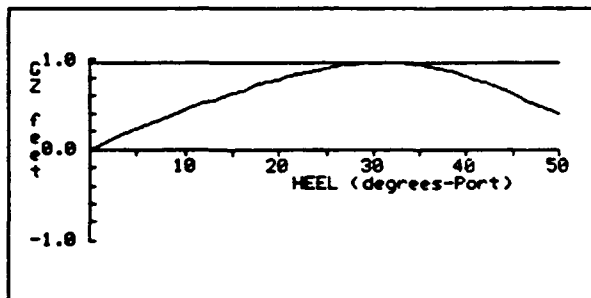

Static Heel = 0.3P deg
 Draft at AP = 5.334 ft
 Draft at FP = 3.038 ft

 Angle at Maximum GZ = 32.00P deg
 Maximum GZ = 0.965 ft
 Range of Positive GZ = 49.73 deg

 Area to 22.0 degrees = 10.02 ft-deg

DPTA006A:
 99' CREW BOAT

COMPARTMENT FLOODING SUMMARY

At 1.70P Heel	PERM.	FLOODED WTR LTons	% FULL (Damaged)	% FULL (Intact)	SP.VOL. ft3/LT	OUTFLOW LTons
ENGINE ROOM	0.85	27.3	FREE	0.0	----	----
FO TANK STBD	0.95	3.4	FREE	100.0	40.6000	3.8
POT H2O STBD	0.95	0.0	FREE	100.0	35.8800	1.1
Totals		30.8				5.0

INTACT DATA

Draft at AP = 3.750 ft Kmt = 13.299 ft LCG = 53.455A ft-FP
 Draft at FP = 3.470 ft VCG = 8.160 ft LCB = 53.473A ft-FP
 Displacement = 78.3 LTons GMT = 5.139 ft TCG = 0.000 ft-CL

DRAFT/GZ DATA

HEEL degrees	RIGHTING ARM ft	DRAFT AFT ft	DRAFT FWD ft	FLOODED WATER LTons
0.00	-0.085	5.279	3.020	31.1
5.00P	0.162	5.239	2.991	30.2
10.00P	0.371	5.210	2.901	29.8
20.00P	0.714	5.090	2.491	29.1
30.00P	0.900	4.785	1.766	28.9
40.00P	0.766	4.557	0.548	28.4
50.00P	0.342	4.400	-1.295	28.2

Note: Drafts are measured at A.P. and F.P along ship's centerline

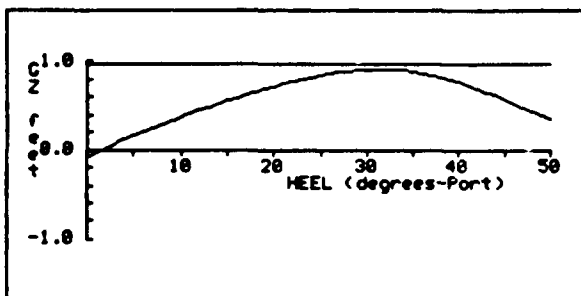

Static Heel = 1.7P deg
 Draft at AP = 5.265 ft
 Draft at FP = 3.012 ft

Angle at Maximum GZ = 32.00P deg
 ** Maximum GZ = 0.983 ft
 Range of Positive GZ = 48.33 deg

Area to 22.0 degrees = 8.61 ft-deg

** indicates criteria is exceeded

DPTA007A:
 99' CREW BOAT

COMPARTMENT FLOODING SUMMARY

At 1.10P Heel	PERM.	FLOODED WTR LTons	% FULL (Damaged)	% FULL (Intact)	SP.VOL. ft3/LT	OUTFLOW LTons
ENGINE ROOM	0.85	27.5	FREE	0.0	----	----
POT H2O STBD	0.95	0.0	FREE	100.0	35.8800	1.1
Totals		27.5				1.1

INTACT DATA

Draft at AP = 3.750 ft KMT = 13.299 ft LCG = 53.455A ft-FP
 Draft at FP = 3.470 ft VCG = 8.160 ft LCB = 53.473A ft-FP
 Displacement = 78.3 LTons GMT = 5.139 ft TCG = 0.000 ft-CL

DRAFT/GZ DATA

HEEL degrees	RIGHTING ARM ft	DRAFT AFT ft	DRAFT FWD ft	FLOODED WATER LTons
0.00	-0.064	5.289	3.022	27.5
5.00P	0.223	5.294	2.989	27.6
10.00P	0.479	5.290	2.923	28.0
20.00P	0.916	5.235	2.536	28.9
30.00P	1.158	5.045	1.799	29.7
40.00P	1.034	4.979	0.563	29.8
50.00P	0.610	5.035	-1.296	29.8

Note: Drafts are measured at A.P. and F.P along ship's centerline

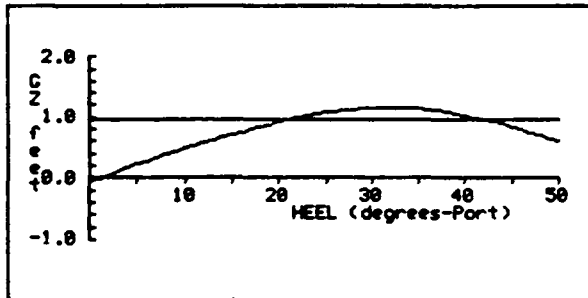

Static Heel = 1.1P deg
 Draft at AP = 3.290 ft
 Draft at FP = 3.016 ft
 Angle at Maximum GZ = 33.00P deg
 Maximum GZ = 1.164 ft
 Range of Positive GZ = 48.92 deg
 Area to 22.0 degrees = 11.19 ft-deg

DPTA008A:
 99' CREW BOAT

COMPARTMENT FLOODING SUMMARY

At 0.0o Heel	PERM.	FLOODED WTR LTons	% FULL (Damaged)	% FULL (Intact)	SP.VOL. ft3/LT	OUTFLOW LTons
LAZARETTE	0.95	27.2	FREE	0.0	----	----
Totals		27.2				

INTACT DATA

Draft at AP = 3.750 ft KMT = 13.299 ft LCG = 53.455A ft-FP
 Draft at FP = 3.470 ft VCG = 8.160 ft LCB = 53.473A ft-FP
 Displacement = 78.3 LTons Gmt = 5.139 ft TCG = 0.000 ft-CL

DRAFT/GZ DATA

HEEL degrees	RIGHTING ARM ft	DRAFT AFT ft	DRAFT FWD ft	FLOODED WATER LTons
0.00	0.000	6.279	1.645	27.2
5.00S	0.318	6.282	1.606	27.3
10.00S	0.634	6.287	1.489	27.4
20.00S	1.186	6.226	1.024	27.2
30.00S	1.423	6.106	0.150	25.7
40.00S	1.246	6.325	-1.497	25.3
50.00S	0.738	7.020	-4.226	25.5

Note: Drafts are measured at A.P. and F.P along ship's centerline

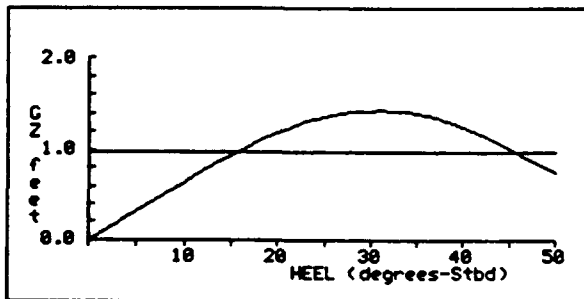

Static Heel = 0.0 deg
 Draft at AP = 6.279 ft
 Draft at FP = 1.645 ft

Gmt (upright damaged) = 3.630 ft
 Angle at Maximum GZ = 32.00S deg
 Maximum GZ = 1.425 ft
 Range of Positive GZ = 50.00 deg

Area to 22.0 degrees = 14.89 ft-deg

RTNA001A:
 99' CREW BOAT

COMPARTMENT FLOODING SUMMARY

At 0.0o Heel	PERM.	FLOODED WTR LTons	% FULL (Damaged)	% FULL (Intact)	SP.VOL. ft3/LT	OUTFLOW LTons
FOREPEAK	0.95	1.3	FREE	0.0	----	----
Totals		1.3				

INTACT DATA

Draft at AP = 3.370 ft Kmt = 14.028 ft LCG = 52.442A ft-FP
 Draft at FP = 3.510 ft VCG = 8.500 ft LCB = 52.432A ft-FP
 Displacement = 70.8 LTons Gmt = 5.528 ft TCG = 0.000 ft-CL

DRAFT/GZ DATA

HEEL degrees	RIGHTING ARM ft	DRAFT AFT ft	DRAFT FWD ft	FLOODED WATER LTons
0.00	0.000	3.284	3.707	1.3
5.00S	0.485	3.290	3.664	1.2
10.00S	0.890	3.256	3.566	1.2
20.00S	1.308	2.945	3.191	1.0
30.00S	1.486	2.232	2.604	0.6
40.00S	1.507	1.058	1.652	0.3
50.00S	1.151	-0.512	0.242	0.0

Note: Drafts are measured at A.P. and F.P along ship's centerline

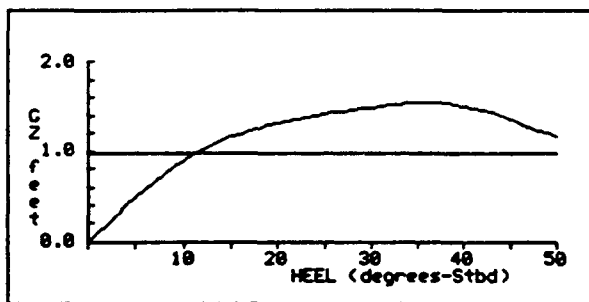

Static Heel = 0.0 deg
 Draft at AP = 3.284 ft
 Draft at FP = 3.707 ft

Gmt (upright damaged) = 5.615 ft
 Angle at Maximum GZ = 37.00S deg
 Maximum GZ = 1.539 ft
 Range of Positive GZ = 50.00 deg

Area to 22.0 degrees = 18.72 ft-deg

RTNA002A:
 99' CREW BOAT

COMPARTMENT FLOODING SUMMARY

At 0.0o Heel	PERM.	FLOODED WTR LTons	% FULL (Damaged)	% FULL (Intact)	SP.VOL. ft3/LT	OUTFLOW LTons
COMPT 2	0.95	8.1	FREE	0.0	----	----
Totals		8.1				

INTACT DATA

Draft at AP = 3.370 ft KMT = 14.028 ft LCG = 52.442A ft-FP
 Draft at FP = 3.510 ft VCG = 8.500 ft LCB = 52.432A ft-FP
 Displacement = 70.8 LTons Gmt = 5.528 ft TCG = 0.000 ft-CL

DRAFT/GZ DATA

HEEL degrees	RIGHTING ARM ft	DRAFT AFT ft	DRAFT FWD ft	FLOODED WATER LTons
0.00	0.000	3.009	4.485	8.1
5.00S	0.477	3.006	4.466	8.1
10.00S	0.897	2.956	4.420	8.3
20.00S	1.333	2.588	4.176	8.6
30.00S	1.516	1.811	3.721	9.0
40.00S	1.417	0.514	3.118	10.2
50.00S	0.898	-1.322	2.393	11.6

Note: Drafts are measured at A.P. and F.P along ship's centerline

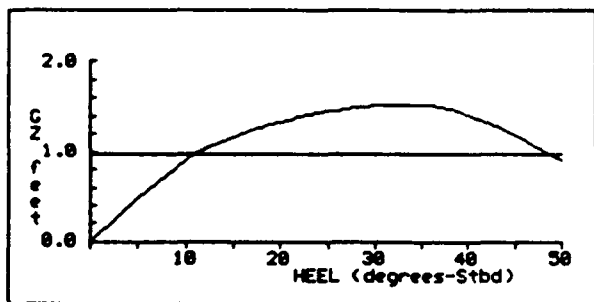

Static Heel = 8.8 deg
 Draft at AP = 3.009 ft
 Draft at FP = 4.485 ft

Gmt (upright damaged) = 5.413 ft
 Angle at Maximum GZ = 34.985 deg
 Maximum GZ = 1.528 ft
 Range of Positive GZ = 50.00 deg

Area to 22.0 degrees = 18.90 ft-deg

RTNA003A:
 99' CREW BOAT

COMPARTMENT FLOODING SUMMARY

At 0.0o Heel	PERM.	FLOODED WTR LTons	% FULL (Damaged)	% FULL (Intact)	SP.VOL. ft3/LT	OUTFLOW LTons
COMPT 3	0.95	40.1	FREE	0.0	----	----
Totals		40.1				

INTACT DATA

Draft at AP = 3.370 ft Kmt = 14.028 ft LCG = 52.442A ft-FP
 Draft at FP = 3.510 ft VCG = 8.500 ft LCB = 52.432A ft-FP
 Displacement = 70.8 LTons GMT = 5.528 ft TCG = 0.000 ft-CL

DRAFT/GZ DATA

HEEL degrees	RIGHTING ARM ft	DRAFT AFT ft	DRAFT FWD ft	FLOODED WATER LTons
0.00	0.000	3.464	5.748	40.1
5.00S	0.283	3.459	5.730	40.1
10.00S	0.583	3.445	5.670	40.1
20.00S	1.024	3.214	5.436	40.4
30.00S	1.252	2.630	4.968	40.8
40.00S	1.089	1.768	4.334	39.9
50.00S	0.579	0.625	3.478	38.7

Note: Drafts are measured at A.P. and F.P along ship's centerline

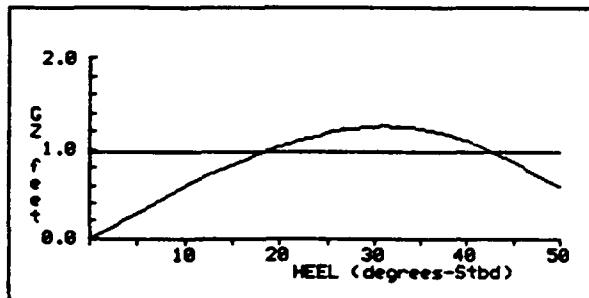

Static Heel = 0.0 deg
 Draft at AP = 3.464 ft
 Draft at FP = 5.748 ft

Gmt (upright damaged) = 3.285 ft
 Angle at Maximum GZ = 32.00S deg
 Maximum GZ = 1.256 ft
 Range of Positive GZ = 58.00 deg

Area to 22.0 degrees = 13.20 ft-deg

RTNA004A:
 99' CREW BOAT

COMPARTMENT FLOODING SUMMARY

At 0.0o Heel	PERM.	FLOODED WTR LTons	% FULL (Damaged)	% FULL (Intact)	SP.VOL. ft3/LT	OUTFLOW LTons
ENGINE ROOM	0.85	24.5	FREE	0.0	----	----
Totals		24.5				

INTACT DATA

Draft at AP = 3.370 ft Kmt = 14.028 ft LCG = 52.442A ft-FP
 Draft at FP = 3.510 ft VCG = 8.500 ft LCB = 52.432A ft-FP
 Displacement = 70.8 LTons Gmt = 5.528 ft TCG = 0.000 ft-CL

DRAFT/GZ DATA

HEEL degrees	RIGHTING ARM ft	DRAFT AFT ft	DRAFT FWD ft	FLOODED WATER LTons
0.00	0.000	4.780	3.136	24.5
5.00S	0.299	4.785	3.098	24.5
10.00S	0.560	4.773	3.026	24.8
20.00S	0.940	4.687	2.634	25.7
30.00S	1.155	4.318	1.969	26.4
40.00S	1.042	3.948	0.823	26.5
50.00S	0.601	3.553	-0.901	26.4

Note: Drafts are measured at A.P. and F.P along ship's centerline

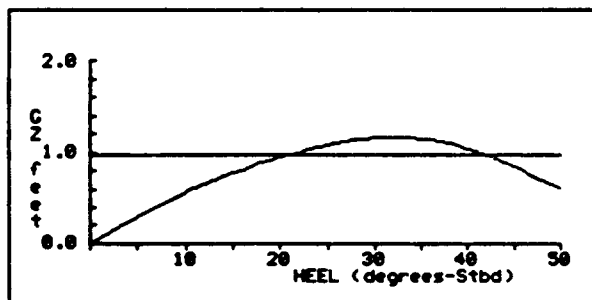

Static Heel = 0.0 deg
 Draft at AP = 4.780 ft
 Draft at FP = 3.136 ft

Gmt (upright damaged) = 3.464 ft
 Angle at Maximum GZ = 33.00S deg
 Maximum GZ = 1.163 ft
 Range of Positive GZ = 50.00 deg

Area to 22.0 degrees = 12.49 ft-deg

RTNA005A:
 99' CREW BOAT

COMPARTMENT FLOODING SUMMARY

At 4.1oS Heel	PERM.	FLOODED WTR LTons	% FULL (Damaged)	% FULL (Intact)	SP.VOL. ft ³ /LT	OUTFLOW LTons
ENGINE ROOM	0.85	25.8	FREE	0.0	----	----
FO TANK STBD	0.95	4.0	FREE	10.0	40.6000	0.4
Totals		29.8				0.4

INTACT DATA

Draft at AP = 3.370 ft KMT = 14.028 ft LCG = 52.442A ft-FP
 Draft at FP = 3.510 ft VCG = 8.500 ft LCB = 52.432A ft-FP
 Displacement = 70.8 LTons GMT = 5.528 ft TCG = 0.000 ft-CL

DRAFT/GZ DATA

HEEL degrees	RIGHTING ARM ft	DRAFT AFT ft	DRAFT FWD ft	FLOODED WATER LTons
0.00	-0.214	4.945	3.173	29.1
5.00S	0.049	4.968	3.164	30.0
10.00S	0.320	4.987	3.083	30.7
20.00S	0.786	4.923	2.699	31.7
30.00S	1.072	4.629	2.011	32.5
40.00S	0.986	4.399	0.839	32.5
50.00S	0.573	4.199	-0.900	32.4

Note: Drafts are measured at A.P. and F.P along ship's centerline

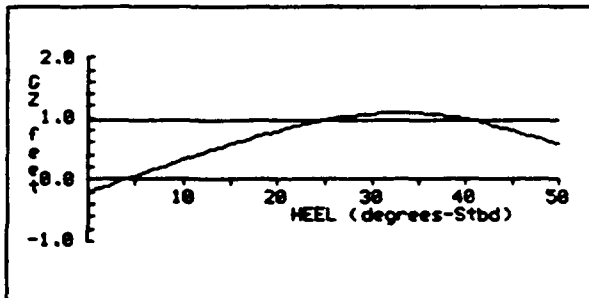

Static Heel = 4.15 deg
 Draft at AP = 4.964 ft
 Draft at FP = 3.169 ft
 Angle at Maximum GZ = 34.00S deg
 Maximum GZ = 1.070 ft
 Range of Positive GZ = 45.92 deg
 Area to 22.0 degrees = 8.23 ft-deg

RTNA006A:
 99' CREW BOAT

COMPARTMENT FLOODING SUMMARY

At 3.9oS Heel	PERM.	FLOODED WTR LTons	% FULL (Damaged)	% FULL (Intact)	SP.VOL. ft3/LT	OUTFLOW LTons
ENGINE ROOM	0.85	25.8	FREE	0.0	----	----
FO TANK STBD	0.95	4.0	FREE	10.0	40.6000	0.4
POT H2O STBD	0.95	0.0	FREE	10.0	35.8800	0.1
Totals		29.7				0.5

INTACT DATA

Draft at AP = 3.370 ft Kmt = 14.028 ft LCG = 52.442A ft-FP
 Draft at FP = 3.510 ft VCG = 8.500 ft LCB = 52.432A ft-FP
 Displacement = 70.8 LTons Gmt = 5.528 ft TCG = 0.000 ft-CL

DRAFT/GZ DATA

HEEL degrees	RIGHTING ARM ft	DRAFT AFT ft	DRAFT FWD ft	FLOODED WATER LTons
0.00	-0.207	4.940	3.171	29.1
5.00S	0.056	4.962	3.162	29.9
10.00S	0.324	4.983	3.082	30.7
20.00S	0.776	4.931	2.703	32.0
30.00S	1.055	4.656	2.017	33.1
40.00S	0.961	4.456	0.845	33.4
50.00S	0.545	4.300	-0.894	33.5

Note: Drafts are measured at A.P. and F.P. along ship's centerline

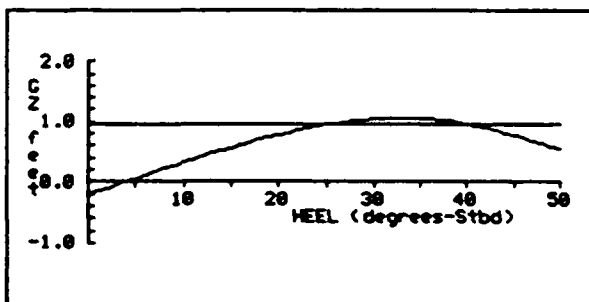

Static Heel = 3.9S deg
 Draft at AP = 4.957 ft
 Draft at FP = 3.167 ft

Angle at Maximum GZ = 34.88S deg
 Maximum GZ = 1.078 ft
 Range of Positive GZ = 46.86 deg

Area to 22.0 degrees = 8.21 ft-deg

RTNA007A:
 99' CREW BOAT

COMPARTMENT FLOODING SUMMARY

At 0.10P Heel	PERM.	FLOODED WTR LTons	% FULL (Damaged)	% FULL (Intact)	SP.VOL. ft3/LT	OUTFLOW LTons
ENGINE ROOM	0.85	24.5	FREE	0.0	----	----
POT H2O STBD	0.95	0.0	FREE	10.0	35.8800	0.1
Totals		24.5				0.1

INTACT DATA

Draft at AP = 3.370 ft KMT = 14.028 ft LCG = 52.442A ft-FP
 Draft at FP = 3.510 ft VCG = 8.500 ft LCB = 52.432A ft-FP
 Displacement = 70.8 LTons GMT = 5.528 ft TCG = 0.000 ft-CL

DRAFT/GZ DATA

HEEL degrees	RIGHTING ARM ft	DRAFT AFT ft	DRAFT FWD ft	FLOODED WATER LTons
0.00	-0.007	4.774	3.134	24.5
5.00P	0.292	4.780	3.096	24.5
10.00P	0.554	4.767	3.024	24.7
20.00P	0.933	4.681	2.631	25.6
30.00P	1.147	4.310	1.968	26.4
40.00P	1.036	3.936	0.822	26.5
50.00P	0.596	3.536	-0.902	26.4

Note: Drafts are measured at A.P. and F.P along ship's centerline

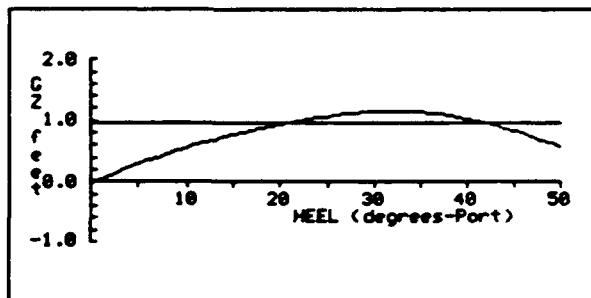

Static Heel = 0.1P deg
 Draft at AP = 4.775 ft
 Draft at FP = 3.133 ft

Angle at Maximum GZ = 33.00P deg
 Maximum GZ = 1.156 ft
 Range of Positive GZ = 49.89 deg

Area to 22.0 degrees = 12.35 ft-deg

RTNA008A:
 99' CREW BOAT

COMPARTMENT FLOODING SUMMARY

At 0.0o Heel	PERM.	FLOODED WTR LTons	% FULL (Damaged)	% FULL (Intact)	SP.VOL. ft3/LT	OUTFLOW LTons
LAZARETTE	0.95	22.9	FREE	0.0	----	----
Totals		22.9				

INTACT DATA

Draft at AP = 3.370 ft	KMt = 14.028 ft	LCG = 52.442A ft-FP
Draft at FP = 3.510 ft	VCG = 8.500 ft	LCB = 52.432A ft-FP
Displacement = 70.8 LTons	Gmt = 5.528 ft	TCG = 0.000 ft-CL

DRAFT/GZ DATA

HEEL degrees	RIGHTING ARM ft	DRAFT AFT ft	DRAFT FWD ft	FLOODED WATER LTons
0.00	0.000	5.518	1.971	22.9
5.00S	0.331	5.509	1.945	22.9
10.00S	0.650	5.515	1.823	23.0
20.00S	1.140	5.396	1.373	22.7
30.00S	1.377	4.983	0.660	21.3
40.00S	1.249	4.735	-0.739	20.8
50.00S	0.749	4.750	-3.122	21.0

Note: Drafts are measured at A.P. and F.P along ship's centerline

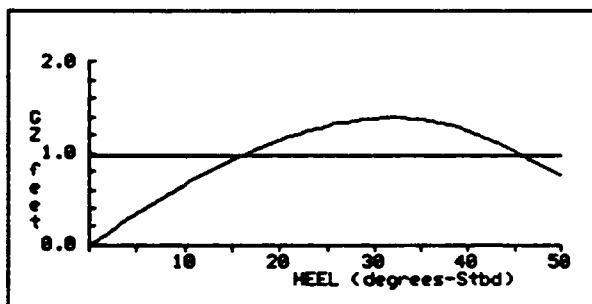

Static Heel = 0.0 deg
 Draft at AP = 5.518 ft
 Draft at FP = 1.971 ft

Gmt (upright damaged) = 3.791 ft
 Angle at Maximum GZ = 33.00S deg
 Maximum GZ = 1.385 ft
 Range of Positive GZ = 50.00 deg

Area to 22.0 degrees = 14.78 ft-deg

**APPENDIX B
HYDROSTATICS AND
DAMAGE STABILITY
OUTPUT**

102' CREW BOAT

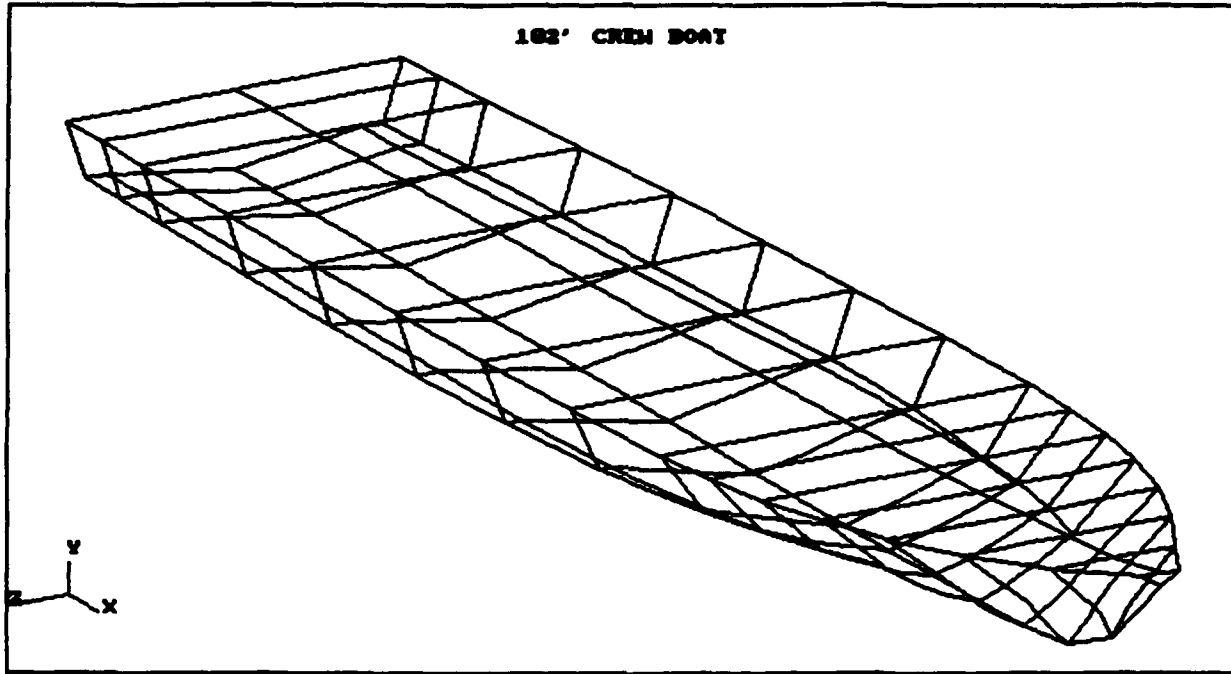

DAMAGE STABILITY SUMMARY
102' CREW BOAT

CASE No.	FILE NAME	DAMAGED COMP.	LISTING	---Intact Condition---			-----Equilibrium Condition After Damage-----					
				MN.DRAFT (ft)	VCG (ft)	GMt (ft)	HEEL (deg)	MAX.GZ (ft)	RANGE (deg)	AREA (ft-deg)	DAM.GMt (ft)	SURVIVAL
1	DPRT001A	1		3.650	7.860	11.300	0.0	3.034	50.0	35.4	11.429	Yes
2	DPRT002A	2		3.650	7.860	11.300	0.0	3.032	50.0	36.3	11.289	Yes
3	DPRT003A	3		3.650	7.860	11.300	0.0	2.488	50.0	29.2	8.064	Yes
4	DPRT004A	8		3.650	7.860	11.300	0.0	2.590	50.0	29.0	8.040	Yes
5	DPRT005A	9		3.650	7.860	11.300	0.0	2.872	50.0	32.7	9.623	Yes
6	DPRT006A	10		3.650	7.860	11.300	0.0	2.958	50.0	34.1	10.533	Yes
7	DPRT007A	4,6		3.650	7.860	11.300	0.1S	2.521	49.9	32.4	----	Yes
8	DPRT008A	4,6,5		3.650	7.860	11.300	0.0S	2.617	50.0	33.7	12.138	Yes
9	DPRT009A	4		3.650	7.860	11.300	0.3S	2.576	49.7	29.3	----	Yes
10	DPRT010A	6		3.650	7.860	11.300	0.0	2.913	50.0	37.5	13.535	Yes
11	DPRT011A	7		3.650	7.860	11.300	1.5P	2.551	48.5	26.4	----	Yes
12	DPRT012A	6,7		3.650	7.860	11.300	1.3P	2.513	48.7	28.9	----	Yes
13	DPRT013A	5,6		3.650	7.860	11.300	0.0P	2.606	50.0	33.0	12.758	Yes
14	DPRT014A	4,5		3.650	7.860	11.300	0.3S	2.654	49.7	30.3	----	Yes

DAMAGE STABILITY SUMMARY
102' CREW BOAT

CA. No.	FILE NAME	DAMAGED COMP. LISTING	---Intact Condition---			-----Equilibrium Condition After Damage-----					
			MM.DRAFT (ft)	VCG (ft)	GMt (ft)	HEEL (deg)	MAX.GZ (ft)	RANGE (deg)	AREA (ft-deg)	DAM.GMT (ft)	SURVIVAL
1	RTRN001B	1	3.240	8.380	12.570	0.0	2.954	50.0	35.8	13.065	Yes
2	RTRN002B	2	3.240	8.380	12.570	0.0	2.966	50.0	37.2	13.618	Yes
3	RTRN003B	3	3.240	8.380	12.570	0.0	2.370	50.0	30.0	9.571	Yes
4	RTRN004B	8	3.240	8.380	12.570	0.0	2.562	50.0	29.7	9.250	Yes
5	RTRN005B	9	3.240	8.380	12.570	0.0	2.830	50.0	33.4	10.658	Yes
6	RTRN006B	10	3.240	8.380	12.570	0.0	2.906	50.0	34.6	11.723	Yes
7	RTRN007B	4,6	3.240	8.380	12.570	0.0S	2.551	50.0	32.7	11.586	Yes
8	RTRN008B	4,6,5	3.240	8.380	12.570	1.2S	2.545	48.8	29.6	----	Yes
9	RTRN009B	4	3.240	8.380	12.570	0.0	2.512	50.0	30.5	11.772	Yes
10	RTRN010B	6	3.240	8.380	12.570	0.0	2.954	50.0	37.8	13.420	Yes
11	RTRN011B	7	3.240	8.380	12.570	1.2P	2.496	48.8	27.0	----	Yes
12	RTRN012B	6,7	3.240	8.380	12.570	1.3P	2.542	48.7	29.2	----	Yes
13	RTRN013B	5,6	3.240	8.380	12.570	0.9S	2.968	49.1	34.9	----	Yes
14	RTRN014B	4,5	3.240	8.380	12.570	1.1S	2.500	48.9	27.4	----	Yes

HYDROSTATIC TABLES
 102' CREW BOAT

MOLDED DRAFT (ft)		0.500	1.000	1.500	2.000	2.500	3.000	3.500	4.000	4.500
DISP. NLD.	(LTons-SW)	2	9	20	35	55	78	103	129	155
DISP. TOTAL	(LTons-SW)	2	9	20	35	55	78	103	129	156
DISP. TOTAL	(LTons-FW)	2	9	19	34	54	76	101	126	152
LCB	(ft-FP)	62.103A	61.919A	62.010A	62.189A	62.518A	62.252A	61.742A	61.189A	60.698A
LCB (forebody)	(ft-FP)	33.432A	33.173A	33.072A	33.055A	33.022A	33.024A	33.041A	32.981A	32.858A
LCB (aftbody)	(ft-FP)	77.439A	77.439A	77.439A	77.441A	77.534A	77.202A	76.944A	76.782A	76.671A
TCB	(ft-CL)	0.000	0.000	0.000	0.000	0.000	0.000	0.000	0.000	0.000
KB	(ft)	0.333	0.667	0.998	1.329	1.664	1.984	2.288	2.582	2.867
B	(ft)	4.455	8.835	13.008	17.433	21.271	19.623	16.977	14.352	12.521
K	(ft)	4.788	9.501	14.006	18.762	22.935	21.607	19.265	16.934	15.388
BMI	(ft)	2479.330	1257.293	831.224	626.147	483.269	375.080	309.007	261.653	227.485
KMI	(ft)	2479.664	1257.959	832.222	627.475	484.933	377.064	311.295	264.234	230.352
TPI	(LTons)	0.7	1.5	2.2	2.9	3.6	4.0	4.2	4.4	4.5
MT1in	(ft-LTons)	4	9	13	18	22	24	26	27	29
CDT1in	(LTons)	0.1	0.2	0.2	0.3	0.4	0.4	0.3	0.3	0.3
LCF	(ft-FP)	62.103A	61.936A	62.241A	62.548A	62.491A	60.831A	59.456A	58.672A	58.043A
W.P. AREA	(ft2)	310	620	919	1,219	1,509	1,679	1,781	1,837	1,885
WETTED SUR.	(ft2)	326	656	979	1,308	1,645	1,873	2,052	2,185	2,315
MAX. BEAM	(ft)	4.294	8.589	12.883	19.848	21.632	22.172	22.373	22.573	22.773
LENGTH W.L.	(ft)	94.469	96.785	97.595	98.405	99.214	100.024	100.834	101.643	101.643
C		0.0603	0.1210	0.1807	0.2394	0.3002	0.3545	0.4000	0.4382	0.4701
Cb (forebody)		0.0420	0.0848	0.1257	0.1645	0.2025	0.2400	0.2770	0.3120	0.3428
Cb (aftbody)		0.0786	0.1571	0.2357	0.3143	0.3978	0.4691	0.5230	0.5644	0.5975
Cm		0.0859	0.1718	0.2577	0.3449	0.4355	0.4993	0.5505	0.5899	0.6215
Cp		0.7020	0.7043	0.7012	0.6941	0.6892	0.7100	0.7266	0.7428	0.7565
Cup		0.1206	0.2416	0.3581	0.4749	0.5880	0.6540	0.6940	0.7155	0.7344
Cit		0.0026	0.0205	0.0677	0.1603	0.3065	0.4007	0.4564	0.4830	0.5086

Assumes: Sea Water at 35.0063 ft3/LT
 Fresh Water at 35.8814 ft3/LT
 Ship floating at even keel (no heel or trim)

DPRT001A: CASE1
 102' CREW BOAT

Managed Compartments:
 VOID

	DISPLACEMENT LTons	DRAFT AFT ft	DRAFT FWD ft	TRIM ft	HEEL deg.	UPRIGHT GMT ft
INTACT	107	3.100	4.200	1.100F	0.0	11.300
DAMAGED	109	2.978	4.473	1.494F	0.0	11.429

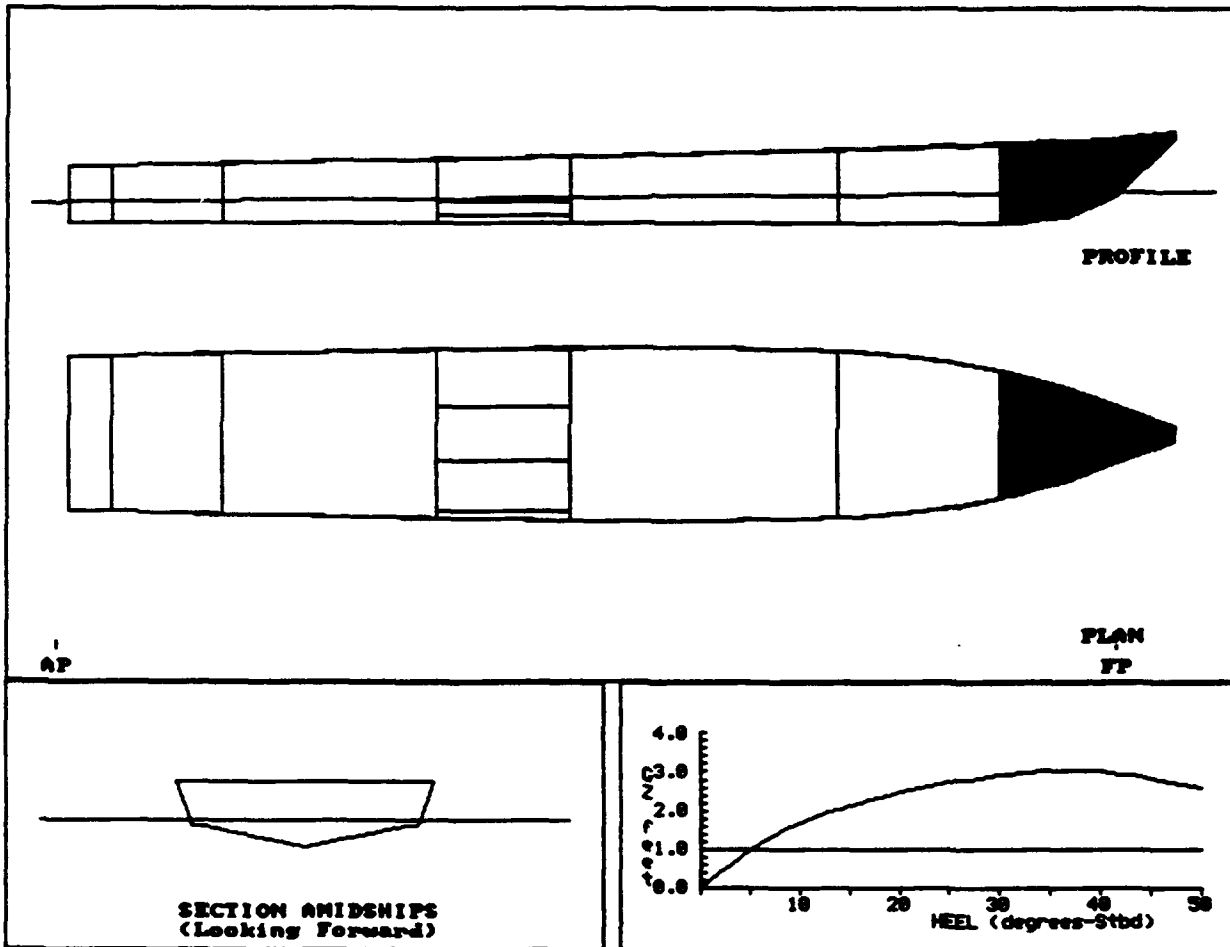

DPRT001A: CASE1
 102' CREW BOAT

COMPARTMENT FLOODING SUMMARY

At 0.0o Heel	PERM.	FLOODED WTR LTons	% FULL (Damaged)	% FULL (Intact)	SP.VOL. ft3/LT	OUTFLOW LTons
VOID	0.95	3	FREE	0.0	----	----
Totals		3				

INTACT DATA

Draft at AP = 3.100 ft KMT = 19.160 ft LCG = 58.406A ft-FP
 Draft at FP = 4.200 ft VCG = 7.860 ft LCB = 58.347A ft-FP
 Displacement = 107 LTons GMT = 11.300 ft TCG = 0.000 ft-CL

DRAFT/GZ DATA

HEEL degrees	RIGHTING ARM ft	DRAFT AFT ft	DRAFT FWD ft	FLOODED WATER LTons
0.0	0.000	2.978	4.473	3
5.0S	0.976	2.987	4.416	2
7.0S	1.307	2.978	4.363	2
10.0S	1.679	2.887	4.300	2
20.0S	2.456	2.332	3.899	2
30.0S	2.908	1.332	3.226	1
40.0S	3.003	0.010	2.126	1
50.0S	2.561	-1.679	0.585	0

Note: Drafts are measured at A.P. and F.P along ship's centerline

GZ SUMMARY (Evaluated per IMO (SOLAS'90) Rules for Passenger Ships)

	Available	Required
Static Heel Angle	0.0 deg	7.0 deg
Angle at Maximum GZ	38.0S deg	
Maximum GZ	3.034 ft	1.000 ft
Range of Positive GZ	50.0 deg	15.0 deg
Gmt (upright damaged)	11.429 ft	
Righting Area (0.0-22.0)	35.38 ft-deg	2.82 ft-deg

DPR002A: CASE2
 102' CREW BOAT

aged Compartments:
 PASSENGERS

	DISPLACEMENT LTons	DRAFT AFT ft	DRAFT FWD ft	TRIM ft	HEEL deg.	UPRIGHT GMT ft
INTACT	107	3.100	4.200	1.100F	0.0	11.300
DAMAGED	124	2.573	5.619	3.046F	0.0	11.289

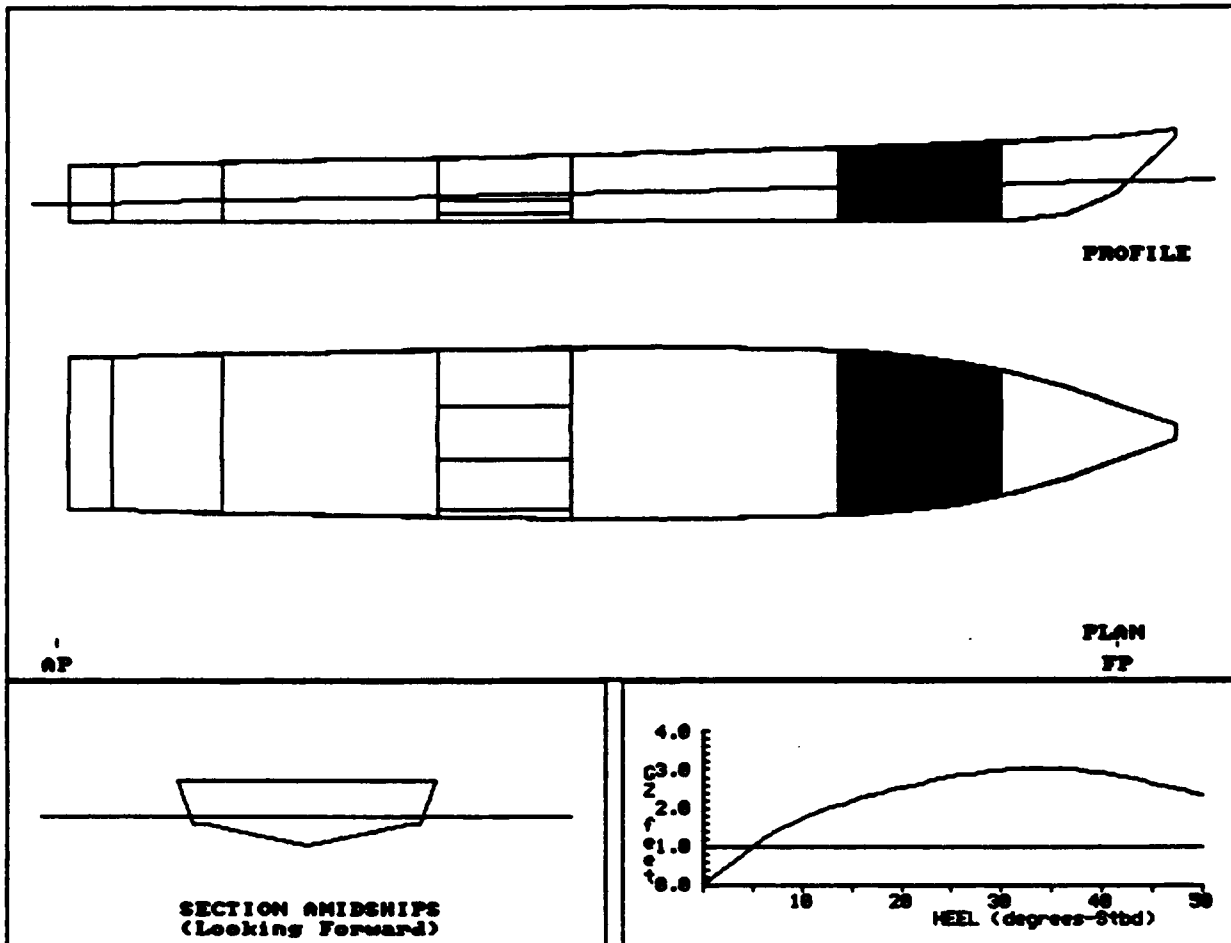

DPRT002A: CASE2
 102' CREW BOAT

COMPARTMENT FLOODING SUMMARY

At 0.0o Heel	PERM.	FLOODED WTR LTons	% FULL (Damaged)	% FULL (Intact)	SP.VOL. ft3/LT	OUTFLOW LTons
PASSGRS	0.95	17	FREE	0.0	----	----
Totals		17				

INTACT DATA

Draft at AP = 3.100 ft	KMT = 19.160 ft	LCG = 58.406A ft-FP
Draft at FP = 4.200 ft	VCG = 7.860 ft	LCB = 58.347A ft-FP
Displacement = 107 LTons	GMT = 11.300 ft	TCG = 0.000 ft-CL

DRAFT/GZ DATA

HEEL degrees	RIGHTING ARM ft	DRAFT AFT ft	DRAFT FWD ft	FLOODED WATER LTons
0.0	0.000	2.573	5.619	17
5.0S	0.985	2.565	5.604	17
7.0S	1.333	2.536	5.592	17
10.0S	1.720	2.446	5.545	17
20.0S	2.531	1.826	5.275	17
30.0S	2.988	0.774	4.724	17
40.0S	2.910	-0.728	4.122	18
50.0S	2.327	-2.768	3.419	19

Note: Drafts are measured at A.P. and F.P along ship's centerline

GZ SUMMARY (Evaluated per IMO (SOLAS'90) Rules for Passenger Ships)

	Available	Required
Static Heel Angle	0.0 deg	7.0 deg
Angle at Maximum GZ	35.0S deg	
Maximum GZ	3.032 ft	1.000 ft
Range of Positive GZ	50.0 deg	15.0 deg
Gmt (upright damaged)	11.289 ft	
Righting Area (0.0-22.0)	36.25 ft-deg	2.82 ft-deg

DPR003A: CASE3
 102' CREW BOAT

anged Compartments:
 CREW

	DISPLACEMENT LTons	DRAFT AFT ft	DRAFT FWD ft	TRIM ft	HEEL deg.	UPRIGHT GMT ft
INTACT	107	3.100	4.200	1.100F	0.0	11.300
DAMAGED	153	2.942	6.363	3.421F	0.0	8.064

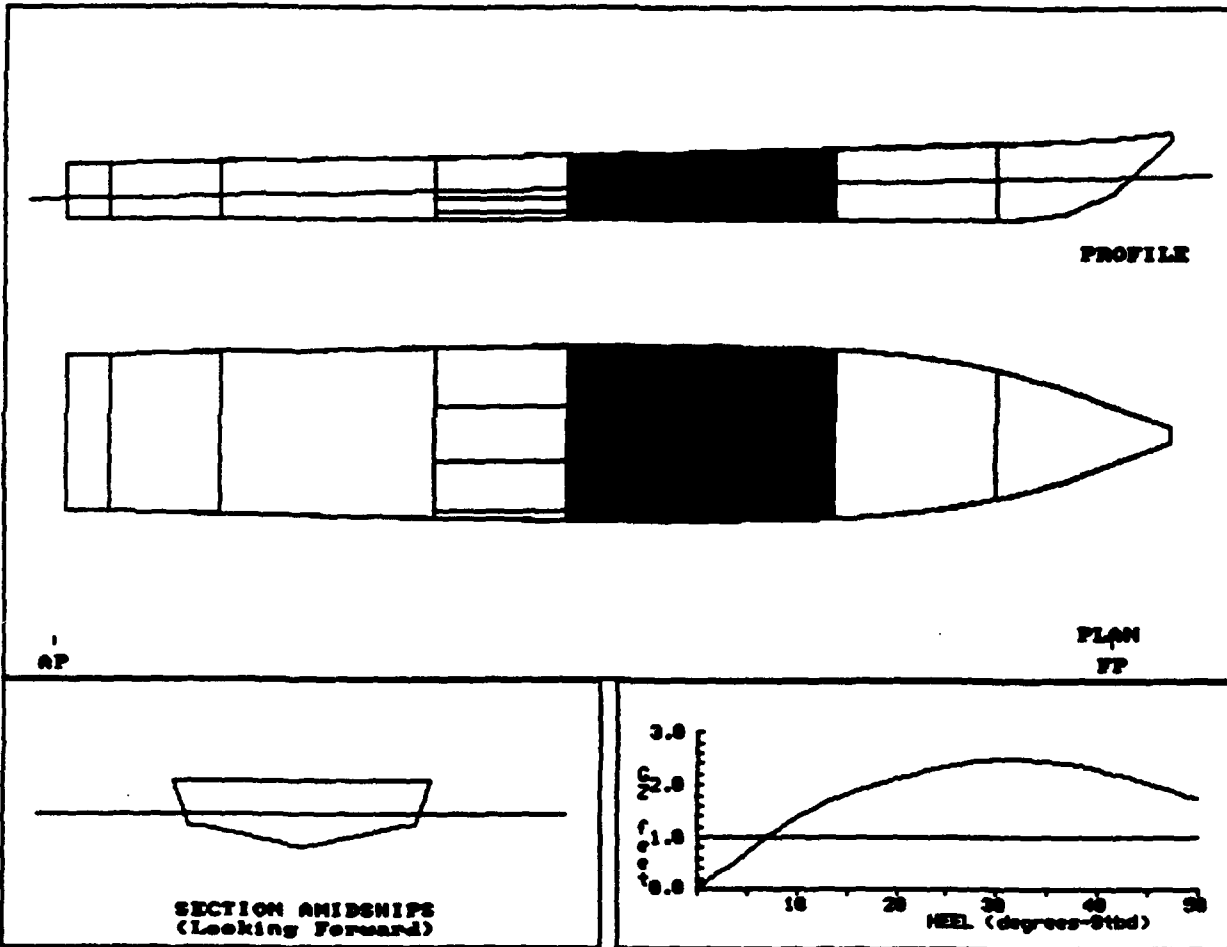

DPRT003A: CASE3
 102' CREW BOAT

COMPARTMENT FLOODING SUMMARY

At 0.0o Heel	PERM.	FLOODED WTR LTons	% FULL (Damaged)	% FULL (Intact)	SP.VOL. ft3/LT	OUTFLOW LTons
CREW	0.95	47	FREE	0.0	----	----
Totals		47				

INTACT DATA

Draft at AP = 3.100 ft	KMt = 19.160 ft	LCG = 58.406A ft-FP
Draft at FP = 4.200 ft	VCG = 7.860 ft	LCB = 58.347A ft-FP
Displacement = 107 LTons	GMT = 11.300 ft	TCG = 0.000 ft-CL

DRAFT/GZ DATA

HEEL degrees	RIGHTING ARM ft	DRAFT AFT ft	DRAFT FWD ft	FLOODED WATER LTons
0.0	0.000	2.942	6.363	47
5.0S	0.708	2.936	6.344	47
7.0S	0.994	2.929	6.328	47
10.0S	1.373	2.883	6.301	47
20.0S	2.105	2.378	6.092	48
30.0S	2.477	1.454	5.663	48
40.0S	2.293	0.298	5.131	48
50.0S	1.734	-1.167	4.443	47

Note: Drafts are measured at A.P. and F.P along ship's centerline

GZ SUMMARY (Evaluated per IMO (SOLAS'90) Rules for Passenger Ships)
 Available Required

Static Heel Angle	0.0 deg	7.0 deg
Angle at Maximum GZ	33.0S deg	
Maximum GZ	2.488 ft	1.000 ft
Range of Positive GZ	50.0 deg	15.0 deg
Gmt (upright damaged)	8.064 ft	
Righting Area (0.0-22.0)	29.23 ft-deg	2.82 ft-deg

DPR004A: CASE4
 102' CREW BOAT

Damaged Compartments:
 ENGRoom

	DISPLACEMENT LTons	DRAFT AFT ft	DRAFT FWD ft	TRIM ft	HEEL deg.	UPRIGHT GMT ft
INTACT	107	3.100	4.200	1.100F	0.0	11.300
DAMAGED	140	4.547	3.769	0.778A	0.0	8.040

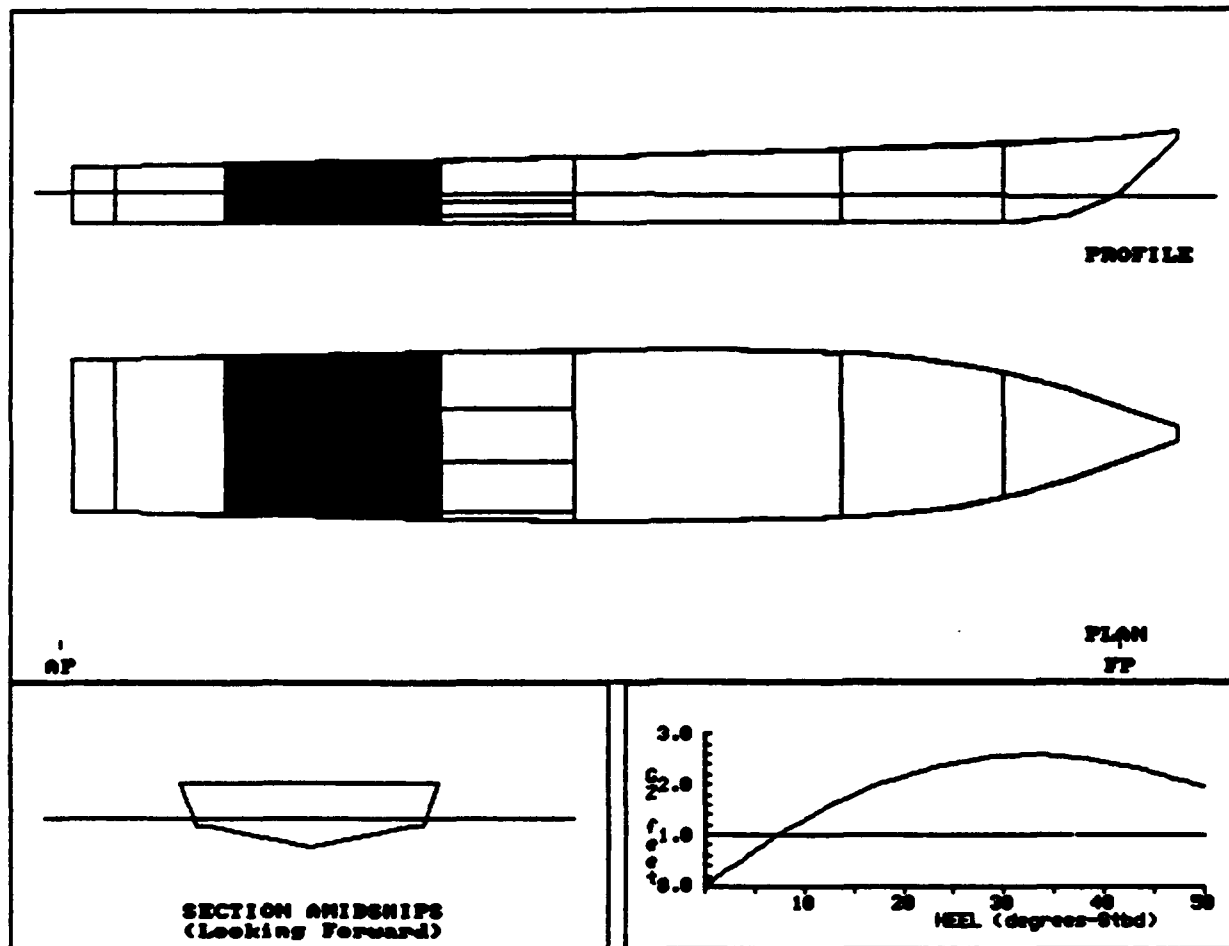

DPRT004A: CASE4
 102' CREW BOAT

COMPARTMENT FLOODING SUMMARY

At 0.0o Heel	PERM.	FLOODED WTR LTons	% FULL (Damaged)	% FULL (Intact)	SP.VOL. ft3/LT	OUTFLOW LTons
ENGROOM	0.85	34	FREE	0.0	----	----
Totals		34				

INTACT DATA

Draft at AP = 3.100 ft	KMt = 19.160 ft	LCG = 58.406A ft-FP
Draft at FP = 4.200 ft	VCG = 7.860 ft	LCB = 58.347A ft-FP
Displacement = 107 LTons	GMT = 11.300 ft	TCG = 0.000 ft-CL

DRAFT/GZ DATA

HEEL degrees	RIGHTING ARM ft	DRAFT AFT ft	DRAFT FWD ft	FLOODED WATER LTons
0.0	0.000	4.547	3.769	34
5.0S	0.693	4.557	3.718	34
7.0S	0.956	4.540	3.696	34
10.0S	1.313	4.524	3.610	33
20.0S	2.165	4.247	3.134	33
30.0S	2.569	3.678	2.337	33
40.0S	2.461	3.163	1.056	33
50.0S	1.969	2.649	-0.798	33

Note: Drafts are measured at A.P. and F.P along ship's centerline

GZ SUMMARY (Evaluated per IMO (SOLAS'90) Rules for Passenger Ships)

	Available	Required
Static Heel Angle	0.0 deg	7.0 deg
Angle at Maximum GZ	34.0S deg	
Maximum GZ	2.590 ft	1.000 ft
Range of Positive GZ	50.0 deg	15.0 deg
Gmt (upright damaged)	8.040 ft	
Righting Area (0.0-22.0)	29.05 ft-deg	2.82 ft-deg

DPR005A: CASE5
 102' CREW BOAT

Damaged Compartments:
 AUX ER

	DISPLACEMENT LTONS	DRAFT AFT ft	DRAFT FWD ft	TRIM ft	HEEL deg.	UPRIGHT GMT ft
INTACT	107	3.100	4.200	1.100F	0.0	11.300
DAMAGED	122	4.055	3.590	0.465A	0.0	9.623

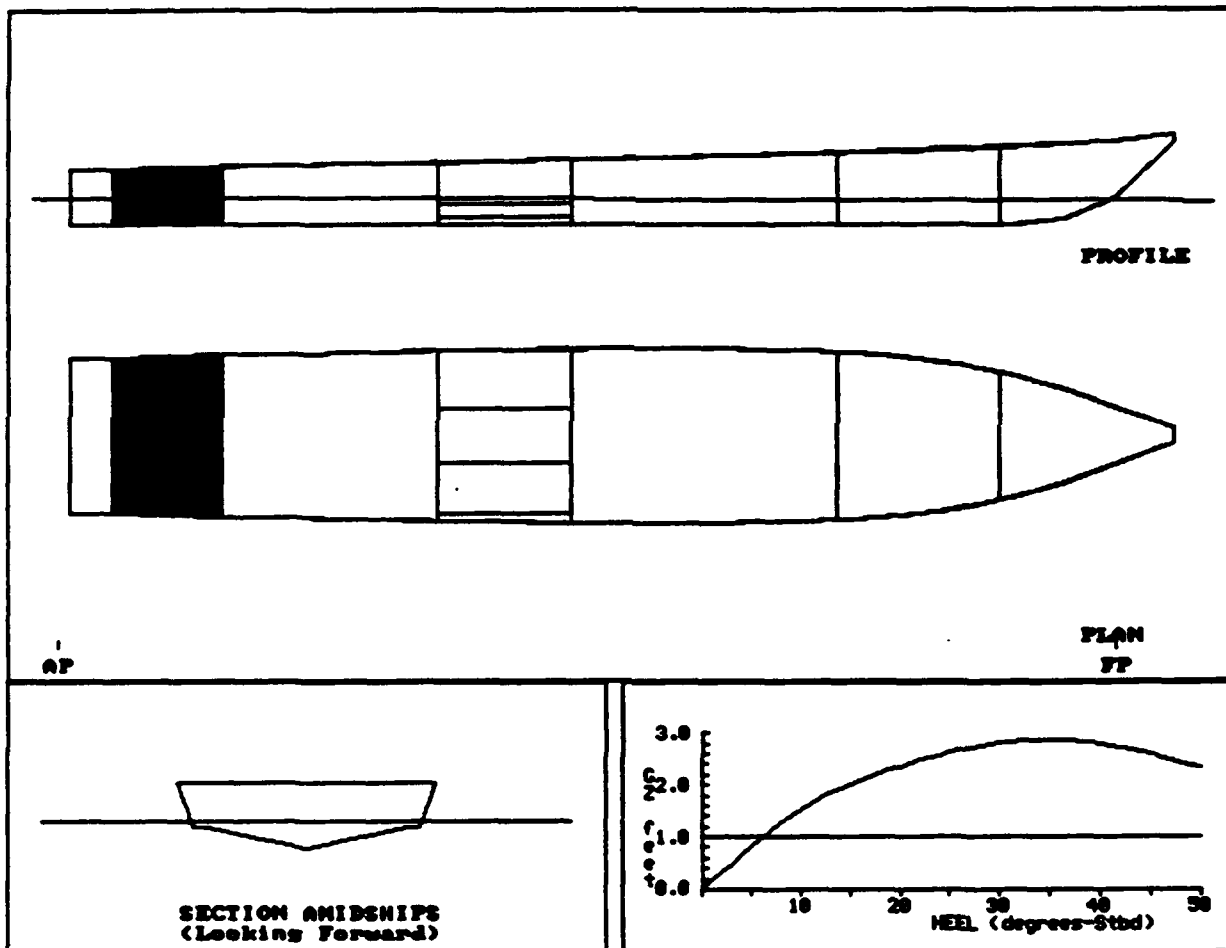

DPRT005A: CASE5
 102' CREW BOAT

COMPARTMENT FLOODING SUMMARY

At 0.0o Heel	PERM.	FLOODED WTR LTons	‡ FULL (Damaged)	‡ FULL (Intact)	SP.VOL. ft3/LT	OUTFLOW LTons
AUX ER	0.85	15	FREE	0.0	----	----
Totals		15				

INTACT DATA

Draft at AP = 3.100 ft	Kmt = 19.160 ft	LCG = 58.406A ft-FP
Draft at FP = 4.200 ft	VCG = 7.860 ft	LCB = 58.347A ft-FP
Displacement = 107 LTons	Gmt = 11.300 ft	TCG = 0.000 ft-CL

DRAFT/GZ DATA

HEEL degrees	RIGHTING ARM ft	DRAFT AFT ft	DRAFT FWD ft	FLOODED WATER LTons
0.0	0.000	4.055	3.590	15
5.0S	0.821	4.057	3.540	15
7.0S	1.125	4.056	3.492	15
10.0S	1.524	4.036	3.390	15
20.0S	2.356	3.620	2.945	14
30.0S	2.814	2.776	2.236	14
40.0S	2.792	1.869	1.008	14
50.0S	2.326	0.855	-0.829	14

Note: Drafts are measured at A.P. and F.P along ship's centerline

GZ SUMMARY (Evaluated per IMO (SOLAS'90) Rules for Passenger Ships)
 Available Required

Static Heel Angle	0.0 deg	7.0 deg
Angle at Maximum GZ	36.0S deg	
Maximum GZ	2.872 ft	1.000 ft
Range of Positive GZ	50.0 deg	15.0 deg
Gmt (upright damaged)	9.623 ft	
Righting Area (0.0-22.0)	32.72 ft-deg	2.82 ft-deg

DPR006A: CASE6
 102' CREW BOAT

Damaged Compartments:
 LAZARETTE

	DISPLACEMENT LTons	DRAFT AFT ft	DRAFT FWD ft	TRIM ft	HEEL deg.	UPRIGHT Gmt ft
INTACT	107	3.100	4.200	1.100F	0.0	11.300
DAMAGED	112	3.496	3.911	0.415F	0.0	10.533

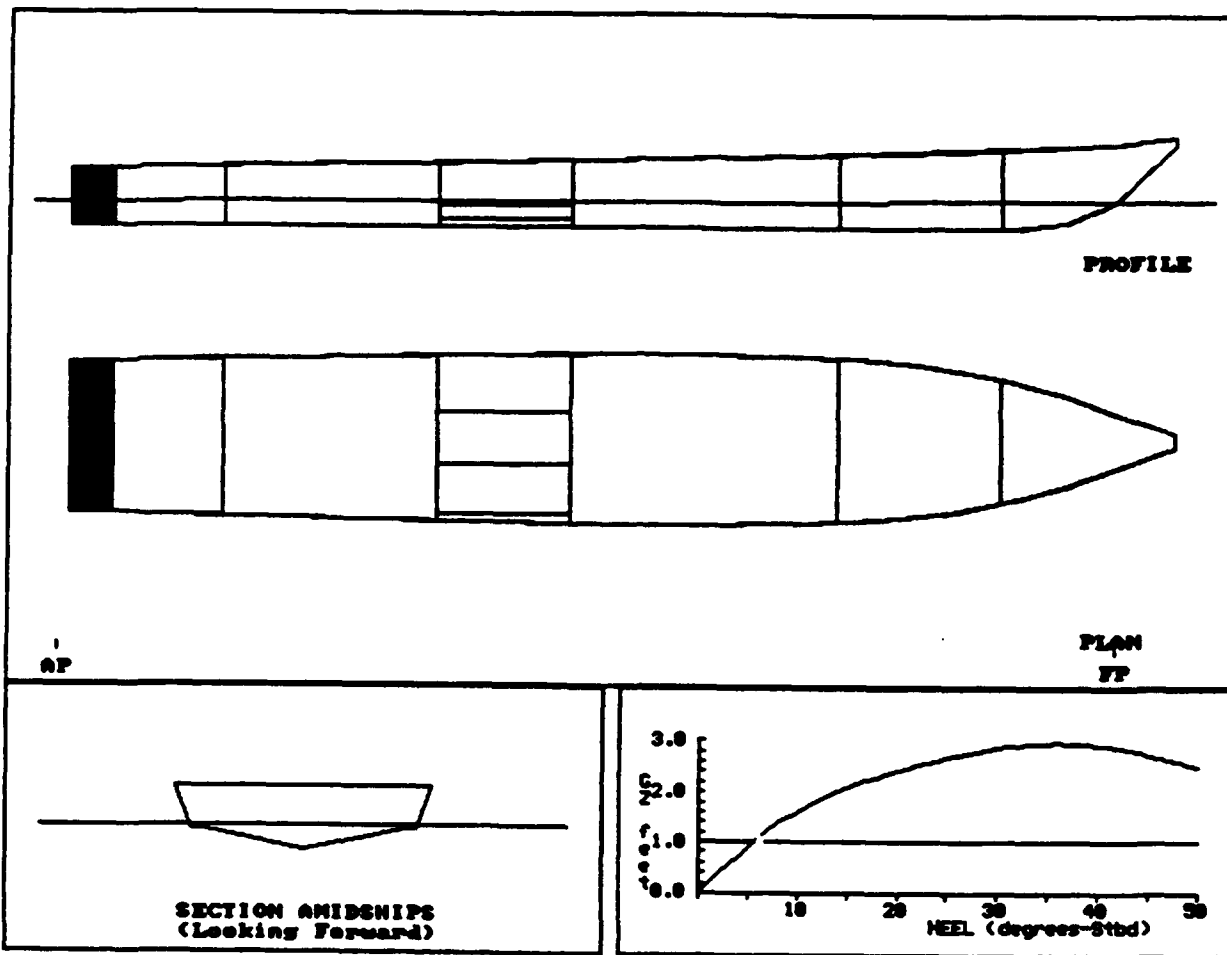

DPRT006A: CASE6
 102' CREW BOAT

COMPARTMENT FLOODING SUMMARY

At 0.0o Heel	PERM.	FLOODED WTR LTons	% FULL (Damaged)	% FULL (Intact)	SP.VOL. ft3/LT	OUTFLOW LTons
LAZARETTE	0.95	5	FREE	0.0	----	----
Totals		5				

INTACT DATA

Draft at AP = 3.100 ft	KMt = 19.160 ft	LCG = 58.406A ft-FP
Draft at FP = 4.200 ft	VCG = 7.860 ft	LCB = 58.347A ft-FP
Displacement = 107 LTons	GMT = 11.300 ft	TCG = 0.000 ft-CL

DRAFT/GZ DATA

HEEL degrees	RIGHTING ARM ft	DRAFT AFT ft	DRAFT FWD ft	FLOODED WATER LTons
0.0	0.000	3.496	3.911	5
5.0S	0.895	3.497	3.862	5
7.0S	1.217	3.493	3.812	5
10.0S	1.608	3.446	3.720	5
20.0S	2.399	2.932	3.323	5
30.0S	2.861	1.958	2.680	5
40.0S	2.914	0.769	1.576	5
50.0S	2.487	-0.662	-0.049	5

Note: Drafts are measured at A.P. and F.P along ship's centerline

GZ SUMMARY (Evaluated per IMO (SOLAS'90) Rules for Passenger Ships)
 Available Required

Static Heel Angle	0.0 deg	7.0 deg
Angle at Maximum GZ	37.0S deg	
Maximum GZ	2.958 ft	1.000 ft
Range of Positive GZ	50.0 deg	15.0 deg
Gmt (upright damaged)	10.533 ft	
Righting Area (0.0-22.0)	34.05 ft-deg	2.82 ft-deg

DPRT007A:
 102' CREW BOAT

amaged Compartments:

TANK ACCESS FO TANK

	DISPLACEMENT LTONS	DRAFT AFT ft	DRAFT FWD ft	TRIM ft	HEEL deg.	UPRIGHT GMT ft
INTACT	107	3.100	4.200	1.100F	0.0	11.300
DAMAGED	93	2.832	3.959	1.128F	0.1S	11.715

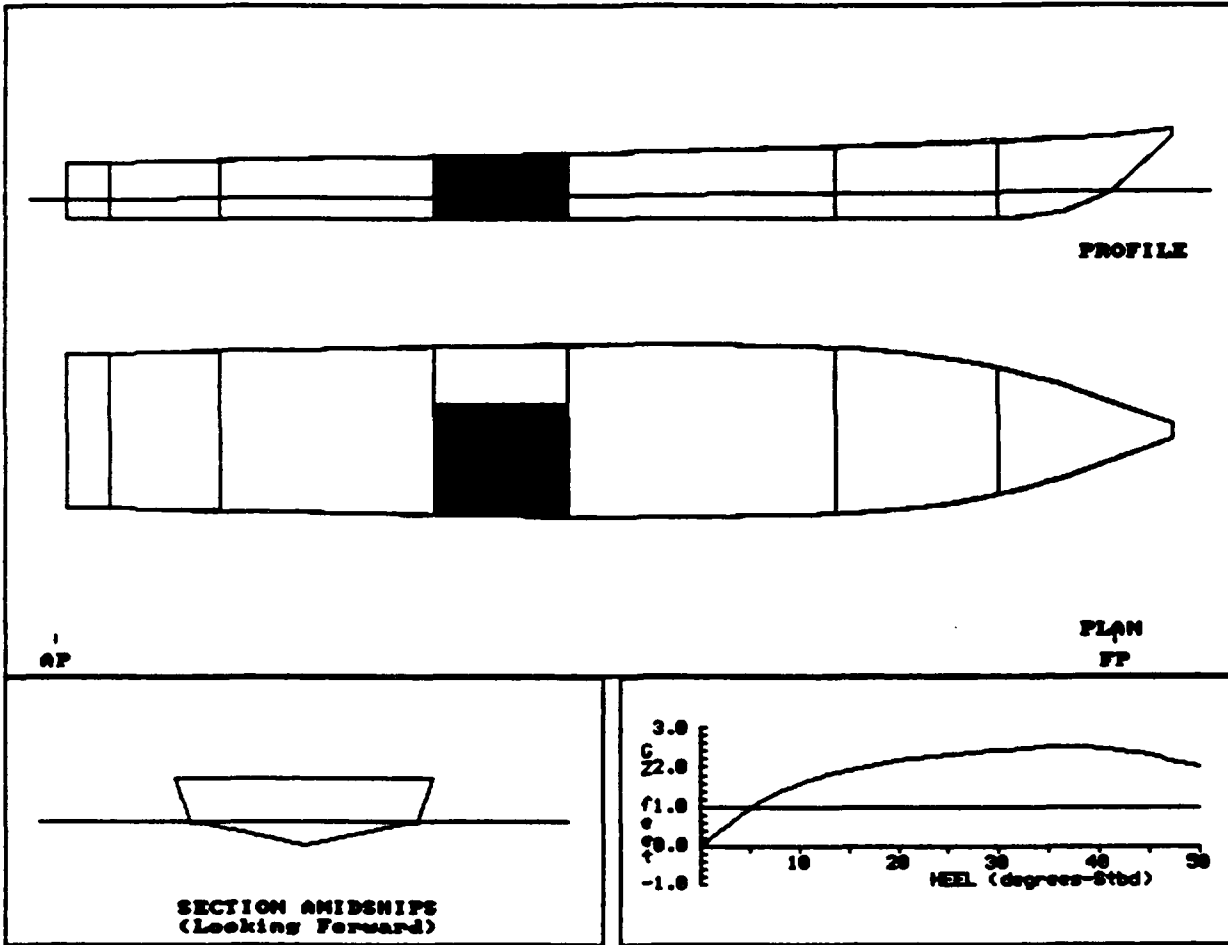

DPRT007A:
 102' CREW BOAT

COMPARTMENT FLOODING SUMMARY

At 0.1oS Heel	PERM.	FLOODED WTR LTons	% FULL (Damaged)	% FULL (Intact)	SP.VOL. ft ³ /LT	OUTFLOW LTons
TANK ACCESS	0.95	0	FREE	0.0	----	----
FO TANK	0.95	8	FREE	100.0	40.6000	21
Totals		8				21

INTACT DATA

Draft at AP = 3.100 ft	KMt = 19.160 ft	LCG = 58.406A ft-FP
Draft at FP = 4.200 ft	VCG = 7.860 ft	LCB = 58.347A ft-FP
Displacement = 107 LTons	GMT = 11.300 ft	TCG = 0.000 ft-CL

DRAFT/GZ DATA

HEEL degrees	RIGHTING ARM ft	DRAFT AFT ft	DRAFT FWD ft	FLOODED WATER LTons
0.0	-0.013	2.831	3.959	8
5.0S	0.956	2.862	3.930	10
7.0S	1.240	2.851	3.880	10
10.0S	1.565	2.758	3.832	11
20.0S	2.164	2.179	3.480	12
30.0S	2.423	1.127	2.875	13
40.0S	2.491	-0.328	1.844	13
50.0S	2.030	-2.272	0.361	13

Note: Drafts are measured at A.P. and F.P along ship's centerline

GZ SUMMARY (Evaluated per IMO (SOLAS'90) Rules for Passenger Ships)

	Available	Required
Static Heel Angle	0.1S deg	7.0 deg
Angle at Maximum GZ	38.0S deg	
Maximum GZ	2.521 ft	1.000 ft
Range of Positive GZ	49.9 deg	15.0 deg
Righting Area (0.1-22.0)	32.40 ft-deg	2.82 ft-deg

DPRT008A:
 102' CREW BOAT

Managed Compartments:

TANK ACCESS N2O TANK FO TANK

	DISPLACEMENT LTons	DRAFT AFT ft	DRAFT FWD ft	TRIM ft	HEEL deg.	UPRIGHT GMT ft
INTACT	107	3.100	4.200	1.100F	0.0	11.300
DAMAGED	93	2.829	3.958	1.128F	0.0S	12.138

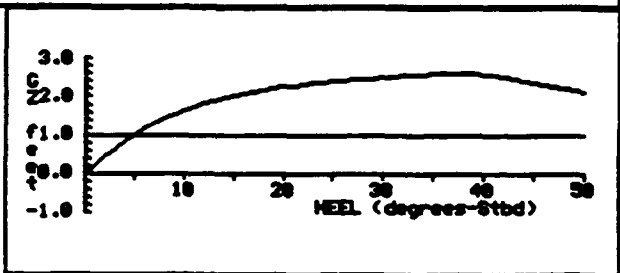
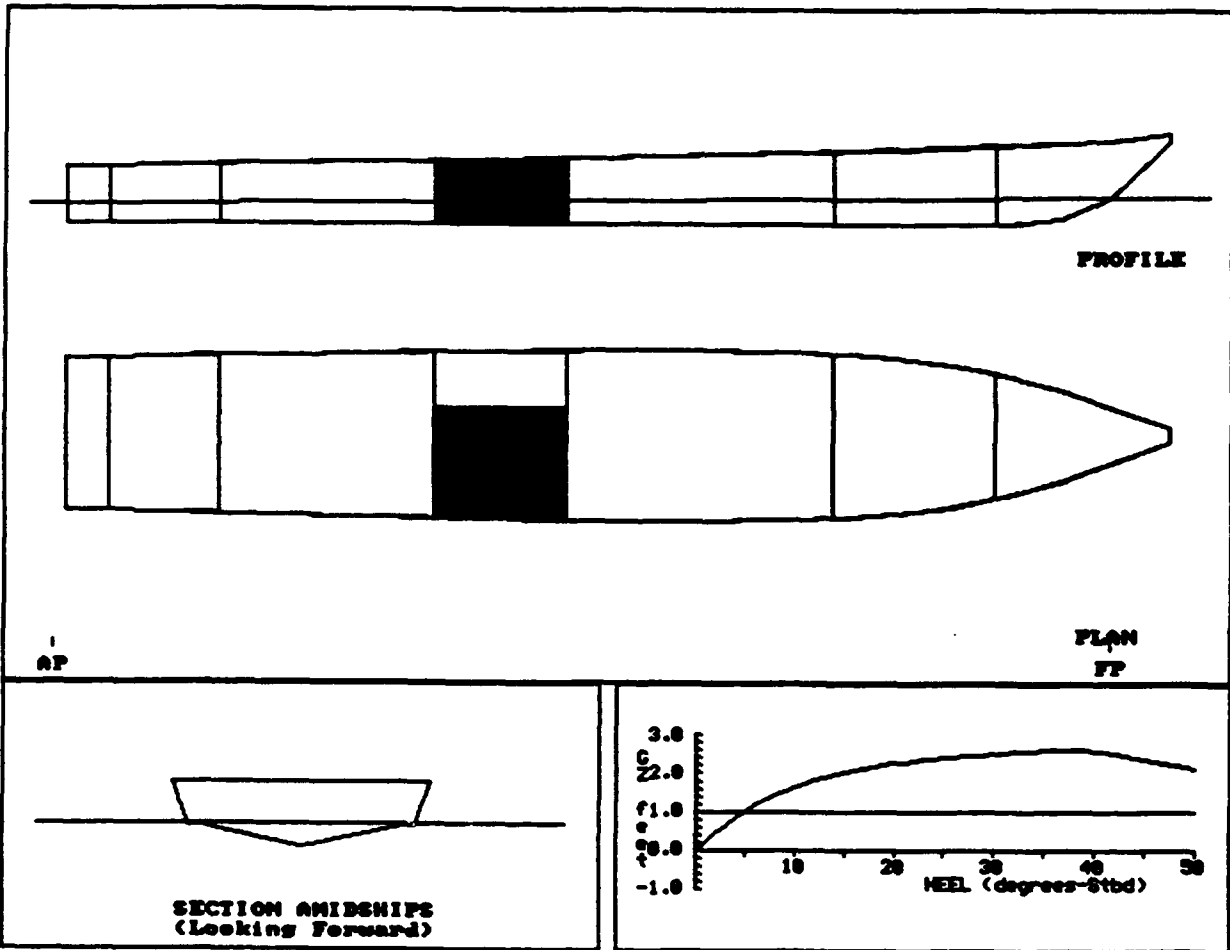

DPRT008A:
 102' CREW BOAT

COMPARTMENT FLOODING SUMMARY

At 0.0oS Heel	PERM.	FLOODED WTR LTons	% FULL (Damaged)	% FULL (Intact)	SP.VOL. ft3/LT	OUTFLOW LTons
TANK ACCESS	0.95	0	FREE	0.0	----	----
H2O TANK	0.95	3	FREE	100.0	34.0000	3
FO TANK	0.95	8	FREE	100.0	40.6000	21
Totals		11				24

INTACT DATA

Draft at AP = 3.100 ft	KMt = 19.160 ft	LCG = 58.406A ft-FP
Draft at FP = 4.200 ft	VCG = 7.860 ft	LCB = 58.347A ft-FP
Displacement = 107 LTons	Gmt = 11.300 ft	TCG = 0.000 ft-CL

DRAFT/GZ DATA

HEEL degrees	RIGHTING ARM ft	DRAFT AFT ft	DRAFT FWD ft	FLOODED WATER LTons
0.0	-0.005	2.829	3.958	11
5.0S	0.999	2.860	3.928	13
7.0S	1.293	2.849	3.878	13
10.0S	1.629	2.755	3.830	14
20.0S	2.249	2.168	3.485	15
30.0S	2.516	1.123	2.873	16
40.0S	2.586	-0.333	1.842	16
50.0S	2.107	-2.280	0.359	16

Note: Drafts are measured at A.P. and F.P along ship's centerline

GZ SUMMARY (Evaluated per IMO (SOLAS'90) Rules for Passenger Ships)
 Available Required

Static Heel Angle	0.0S deg	7.0 deg
Angle at Maximum GZ	38.0S deg	
Maximum GZ	2.617 ft	1.000 ft
Range of Positive GZ	50.0 deg	15.0 deg
Gmt (upright damaged)	12.138 ft	
Righting Area (0.0-22.0)	33.74 ft-deg	2.82 ft-deg

DPRT009A:
 102' CREW BOAT

Damaged Compartments:
 TANK ACCESS

	DISPLACEMENT LTons	DRAFT AFT ft	DRAFT FWD ft	TRIM ft	HEEL deg.	UPRIGHT GMT ft
INTACT	107	3.100	4.200	1.100F	0.0	11.300
DAMAGED	108	3.112	4.225	1.113F	0.35	9.736

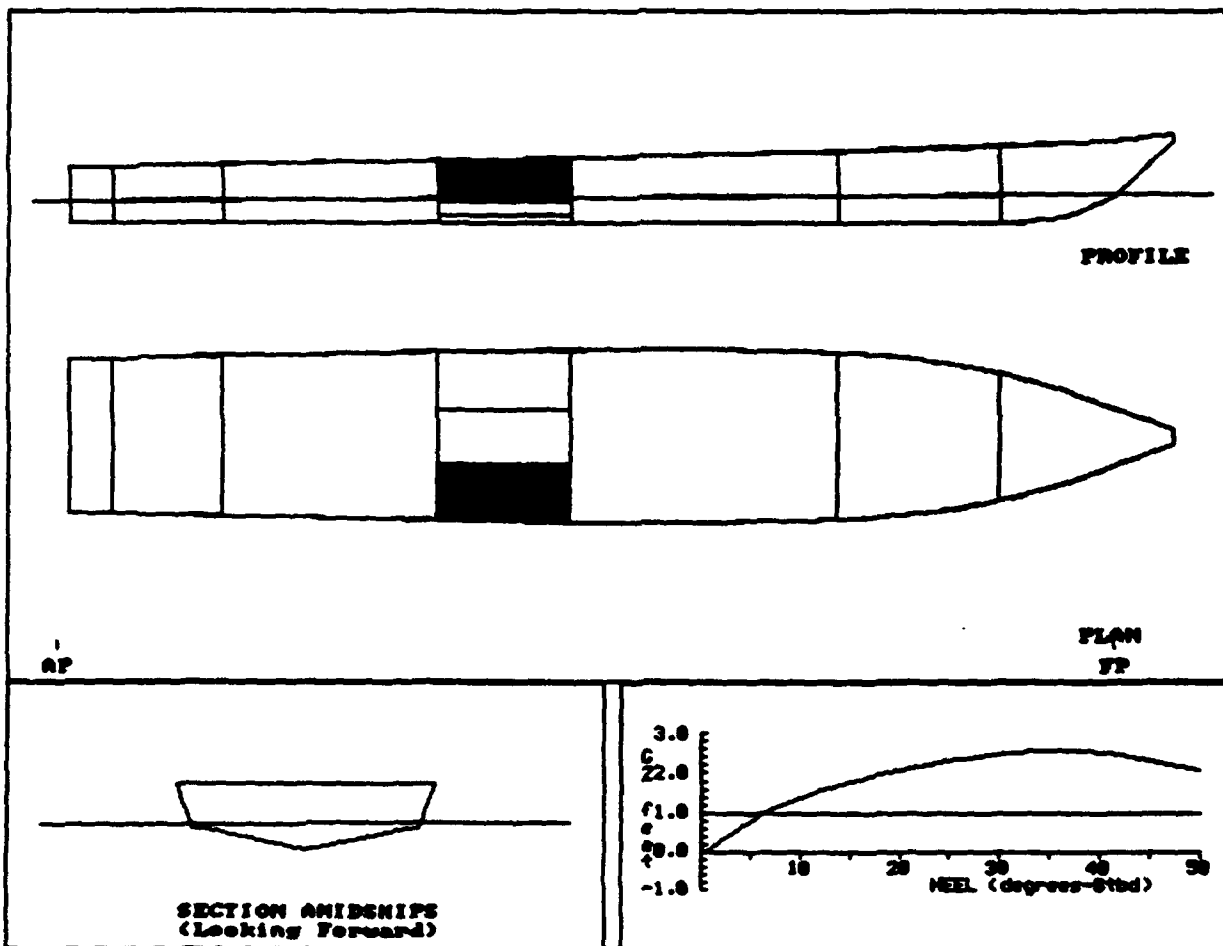

DPRT009A:
 102' CREW BOAT

COMPARTMENT FLOODING SUMMARY

At 0.3oS Heel	PERM.	FLOODED WTR LTons	% FULL (Damaged)	% FULL (Intact)	SP.VOL. ft ³ /LT	OUTFLOW LTons
TANK ACCESS	0.95	1	FREE	0.0	----	----
Totals		1				

INTACT DATA

Draft at AP = 3.100 ft	KMt = 19.160 ft	LCG = 58.406A ft-FP
Draft at FP = 4.200 ft	VCG = 7.860 ft	LCB = 58.347A ft-FP
Displacement = 107 LTons	Gmt = 11.300 ft	TCG = 0.000 ft-CL

DRAFT/GZ DATA

HEEL degrees	RIGHTING ARM ft	DRAFT AFT ft	DRAFT FWD ft	FLOODED WATER LTons
0.0	-0.059	3.109	4.225	1
5.0S	0.773	3.148	4.205	3
7.0S	1.065	3.163	4.158	3
10.0S	1.392	3.110	4.105	4
20.0S	2.071	2.653	3.787	7
30.0S	2.490	1.765	3.217	10
40.0S	2.528	0.654	2.246	12
50.0S	2.094	-0.693	0.824	13

Note: Drafts are measured at A.P. and F.P along ship's centerline

GZ SUMMARY (Evaluated per IMO (SOLAS'90) Rules for Passenger Ships)
 Available Required

Static Heel Angle	0.3S deg	7.0 deg
Angle at Maximum GZ	37.0S deg	
Maximum GZ	2.576 ft	1.000 ft
Range of Positive GZ	49.7 deg	15.0 deg
Righting Area (0.3-22.0)	29.27 ft-deg	2.82 ft-deg

DPR010A:
 102' CREW BOAT

Damaged Compartments:
 FO TANK

	DISPLACEMENT LTons	DRAFT AFT ft	DRAFT FWD ft	TRIM ft	HEEL deg.	UPRIGHT GMT ft
INTACT	107	3.100	4.200	1.100F	0.0	11.300
DAMAGED	93	2.829	3.956	1.127F	0.0	13.535

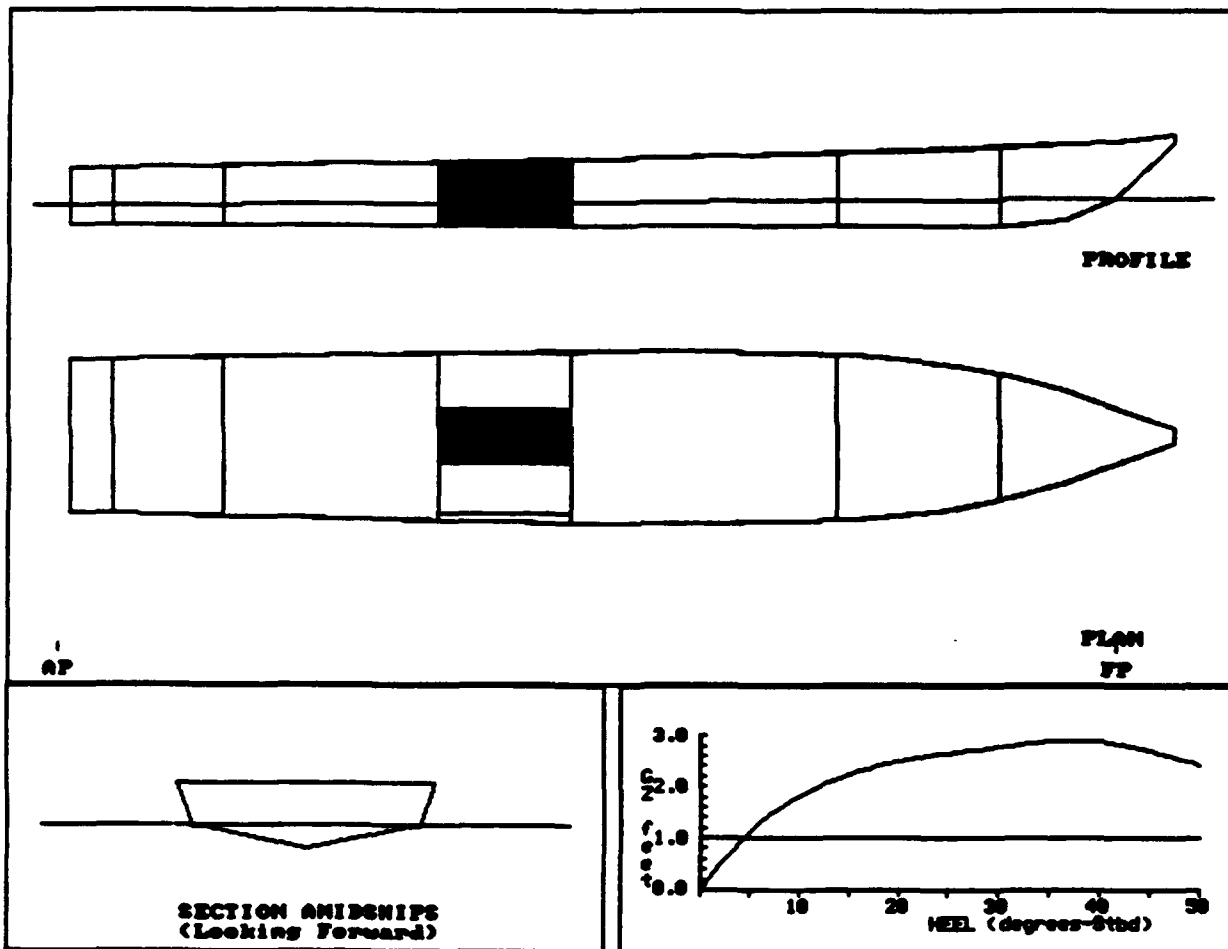

DPRT010A:
 102' CREW BOAT

COMPARTMENT FLOODING SUMMARY

At 0.0o Heel	PERM.	FLOODED WTR LTons	% FULL (Damaged)	% FULL (Intact)	SP.VOL. ft3/LT	OUTFLOW LTons
FO TANK	0.95	8	FREE	100.0	40.6000	21
Totals		8				21

INTACT DATA

Draft at AP = 3.100 ft	KMT = 19.160 ft	LCG = 58.406A ft-FP
Draft at FP = 4.200 ft	VCG = 7.860 ft	LCB = 58.347A ft-FP
Displacement = 107 LTons	GMT = 11.300 ft	TCG = 0.000 ft-CL

DRAFT/GZ DATA

HEEL degrees	RIGHTING ARM ft	DRAFT AFT ft	DRAFT FWD ft	FLOODED WATER LTons
0.0	0.000	2.829	3.956	8
5.0S	1.113	2.835	3.873	8
7.0S	1.434	2.779	3.844	8
10.0S	1.807	2.668	3.762	7
20.0S	2.493	1.972	3.360	6
30.0S	2.780	0.806	2.698	4
40.0S	2.892	-0.864	1.622	2
50.0S	2.422	-3.167	0.052	1

Note: Drafts are measured at A.P. and F.P along ship's centerline

GZ SUMMARY (Evaluated per IMO (SOLAS'90) Rules for Passenger Ships)
 Available Required

Static Heel Angle	0.0 deg	7.0 deg
Angle at Maximum GZ	39.0S deg	
Maximum GZ	2.913 ft	1.000 ft
Range of Positive GZ	50.0 deg	15.0 deg
Gmt (upright damaged)	13.535 ft	
Righting Area (0.0-22.0)	37.46 ft-deg	2.82 ft-deg

DPR011A:
 102' CREW BOAT

amaged Compartments:
 TANK VOID

	DISPLACEMENT LTONS	DRAFT AFT ft	DRAFT FWD ft	TRIM ft	HEEL deg.	UPRIGHT GMT ft
INTACT	107	3.100	4.200	1.100F	0.0	11.300
DAMAGED	111	3.190	4.273	1.083F	1.5P	9.887

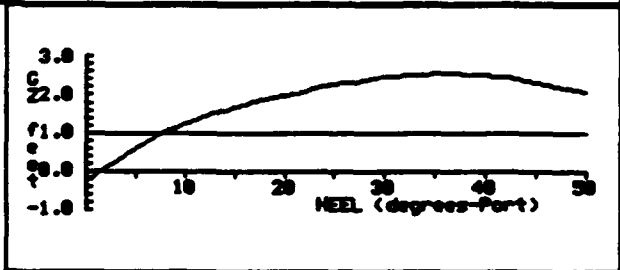
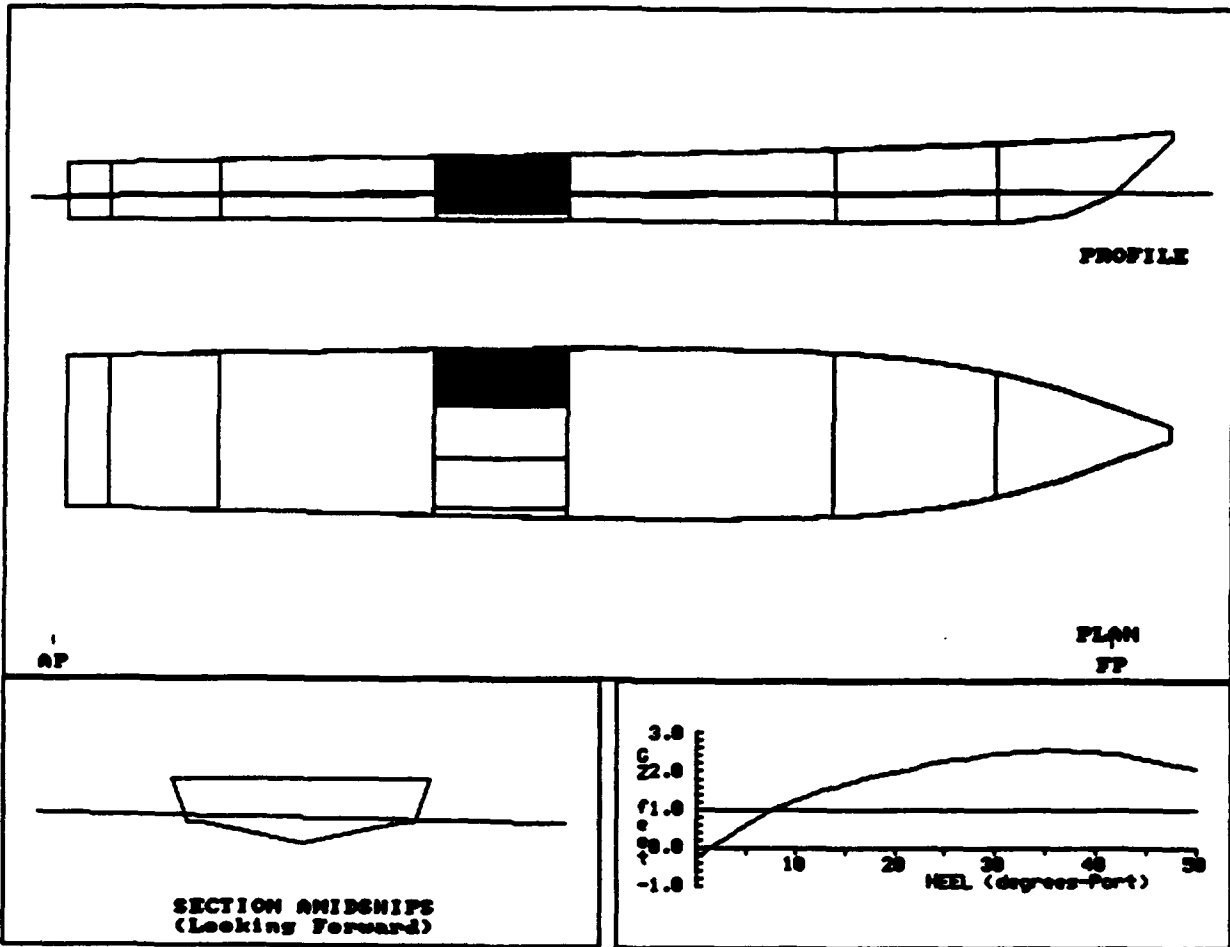

DPRTO11A:
 102' CREW BOAT

COMPARTMENT FLOODING SUMMARY

At 1.5oP Heel	PERM.	FLOODED WTR LTons	% FULL (Damaged)	% FULL (Intact)	SP.VOL. ft3/LT	OUTFLOW LTons
TANK VOID	0.95	5	FREE	0.0	----	----
Totals		5				

INTACT DATA

Draft at AP = 3.100 ft	KMt = 19.160 ft	LCG = 58.406A ft-FP
Draft at FP = 4.200 ft	VCG = 7.860 ft	LCB = 58.347A ft-FP
Displacement = 107 LTons	GMT = 11.300 ft	TCG = 0.000 ft-CL

DRAFT/GZ DATA

HEEL degrees	RIGHTING ARM ft	DRAFT AFT ft	DRAFT FWD ft	FLOODED WATER LTons
0.0	-0.260	3.182	4.269	4
5.0P	0.588	3.214	4.262	6
7.0P	0.894	3.230	4.218	6
10.0P	1.246	3.187	4.162	7
20.0P	1.984	2.747	3.844	10
30.0P	2.455	1.878	3.273	13
40.0P	2.505	0.817	2.304	15
50.0P	2.083	-0.457	0.886	17

Note: Drafts are measured at A.P. and F.P along ship's centerline

GZ SUMMARY (Evaluated per IMO (SOLAS'90) Rules for Passenger Ships)
 Available Required

Static Heel Angle	1.5P deg	7.0 deg
Angle at Maximum GZ	37.0P deg	
Maximum GZ	2.551 ft	1.000 ft
Range of Positive GZ	48.5 deg	15.0 deg
Righting Area (1.5-22.0)	26.35 ft-deg	2.82 ft-deg

DPRT012A:
 102' CREW BOAT

Damaged Compartments:
 FO TANK TANK VOID

	DISPLACEMENT LTONS	DRAFT AFT ft	DRAFT FWD ft	TRIM ft	HEEL deg.	UPRIGHT GMT ft
INTACT	107	3.100	4.200	1.100F	0.0	11.300
DAMAGED	97	2.909	4.019	1.110F	1.3P	12.011

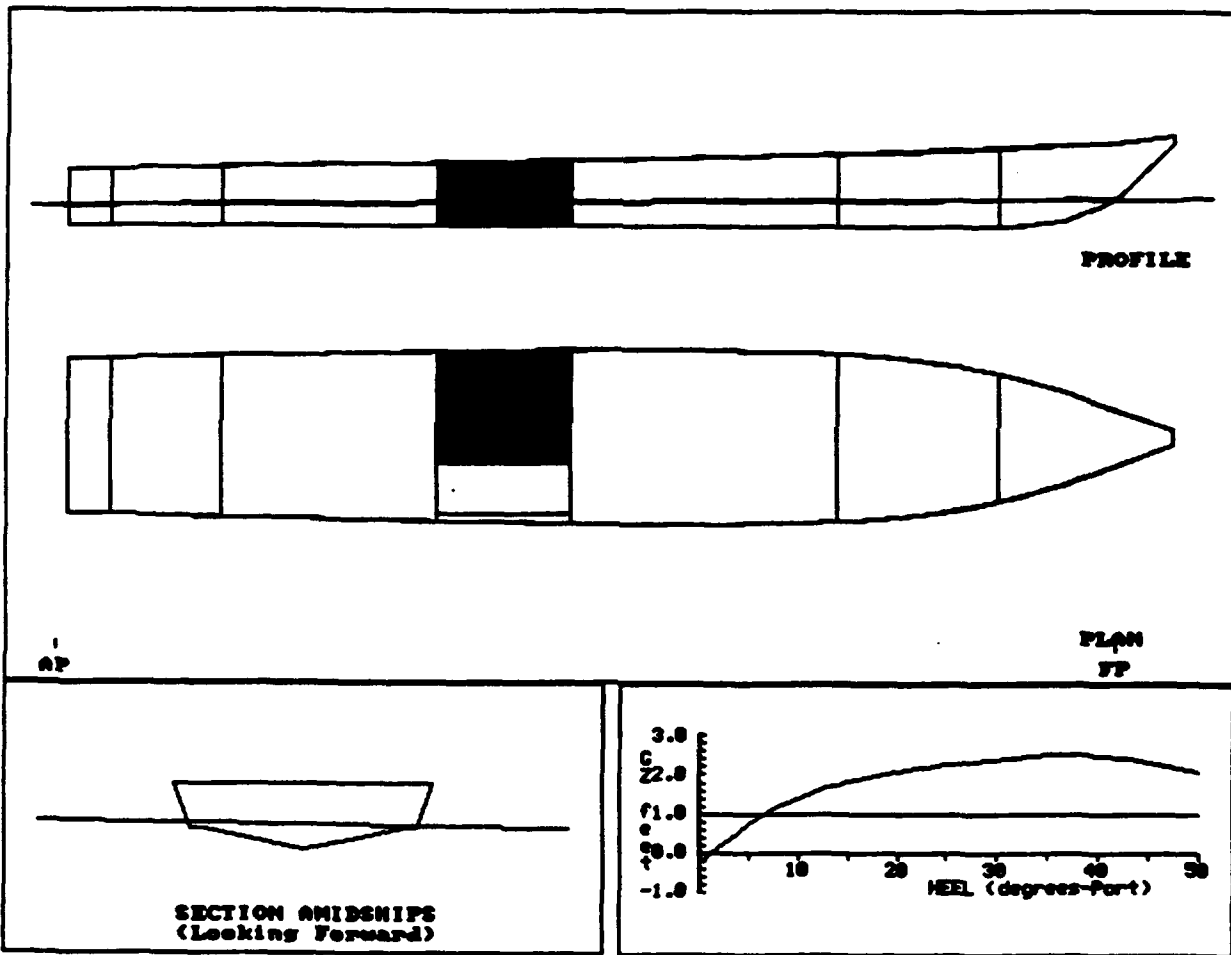

**DPRT012A:
 102' CREW BOAT**

COMPARTMENT FLOODING SUMMARY

At 1.30P Heel	PERM.	FLOODED WTR LTons	% FULL (Damaged)	% FULL (Intact)	SP.VOL. ft3/LT	OUTFLOW LTons
FO TANK	0.95	8	FREE	100.0	40.6000	21
TANK VOID	0.95	4	FREE	0.0	----	----
Totals		12				21

INTACT DATA

Draft at AP = 3.100 ft KMT = 19.160 ft LCG = 58.406A ft-FP
 Draft at FP = 4.200 ft VCG = 7.860 ft LCB = 58.347A ft-FP
 Displacement = 107 LTons GMT = 11.300 ft TCG = 0.000 ft-CL

DRAFT/GZ DATA

HEEL degrees	RIGHTING ARM ft	DRAFT AFT ft	DRAFT FWD ft	FLOODED WATER LTons
0.0	-0.264	2.900	4.020	11
5.0P	0.735	2.933	3.996	13
7.0P	1.044	2.929	3.945	14
10.0P	1.394	2.844	3.896	14
20.0P	2.069	2.286	3.546	16
30.0P	2.395	1.253	2.940	16
40.0P	2.489	-0.158	1.912	16
50.0P	2.051	-2.011	0.438	16

Note: Drafts are measured at A.P. and F.P along ship's centerline

GZ SUMMARY (Evaluated per IMO (SOLAS'90) Rules for Passenger Ships)

	Available	Required
Static Heel Angle	1.3P deg	7.0 deg
Angle at Maximum GZ	38.0P deg	
Maximum GZ	2.513 ft	1.000 ft
Range of Positive GZ	48.7 deg	15.0 deg
Righting Area (1.3-22.0)	28.90 ft-deg	2.82 ft-deg

DFRT013A:
 102' CREW BOAT

Imaged Compartments:

H2O TANK FO TANK

	DISPLACEMENT LTons	DRAFT AFT ft	DRAFT FWD ft	TRIM ft	HEEL deg.	UPRIGHT Gmt ft
INTACT	107	3.100	4.200	1.100F	0.0	11.300
DAMAGED	93	2.827	3.954	1.127F	0.0P	12.758

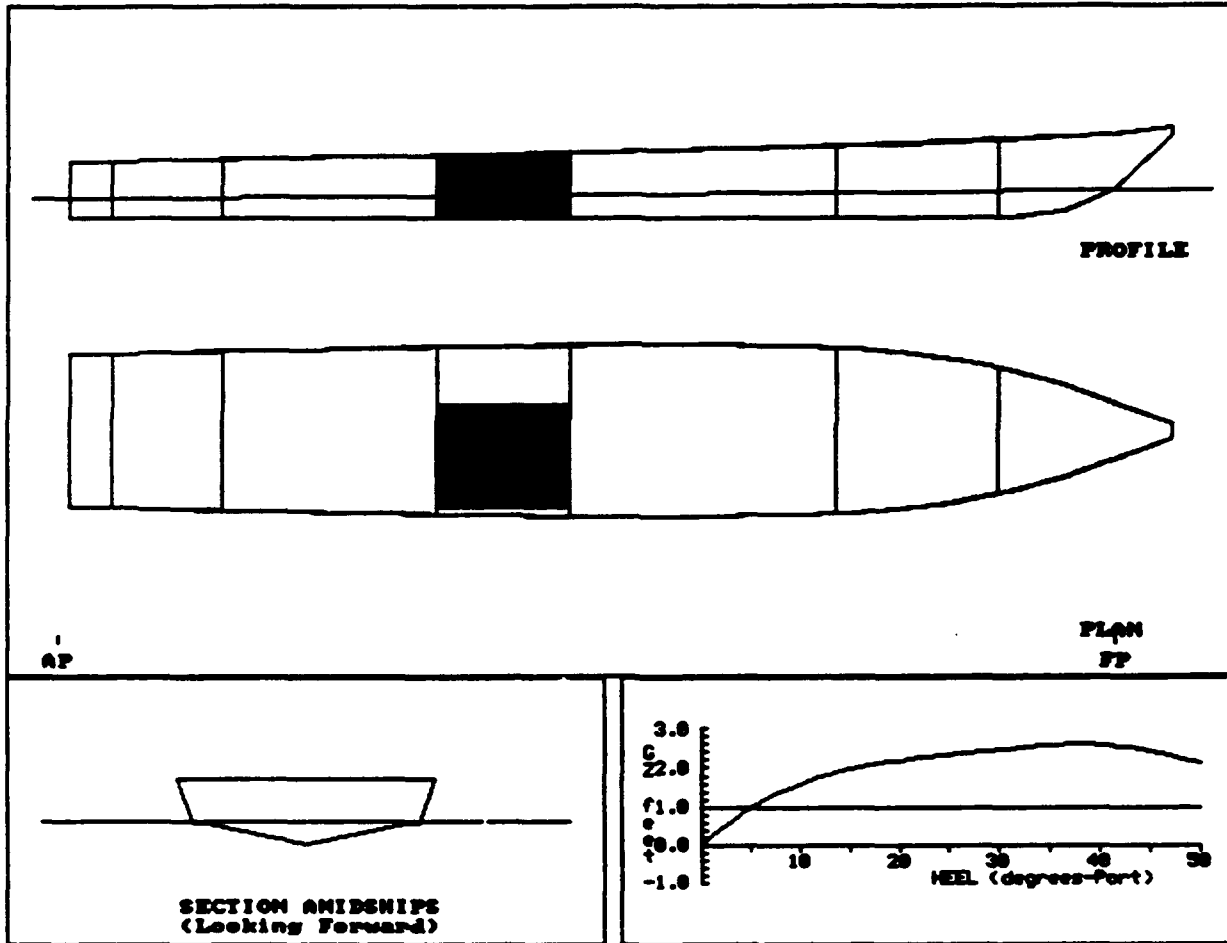

DPRT013A:
 102' CREW BOAT

COMPARTMENT FLOODING SUMMARY

At 0.0oP Heel	PERM.	FLOODED WTR LTons	% FULL (Damaged)	% FULL (Intact)	SP.VOL. ft3/LT	OUTFLOW LTons
H2O TANK	0.95	3	FREE	100.0	34.0000	3
FO TANK	0.95	8	FREE	100.0	40.6000	21
Totals		11				24

INTACT DATA

Draft at AP = 3.100 ft KMT = 19.160 ft LCG = 58.406A ft-FP
 Draft at FP = 4.200 ft VCG = 7.860 ft LCB = 58.347A ft-FP
 Displacement = 107 LTons GMT = 11.300 ft TCG = 0.000 ft-CL

DRAFT/GZ DATA

HEEL degrees	RIGHTING ARM ft	DRAFT AFT ft	DRAFT FWD ft	FLOODED WATER LTons
0.0	-0.008	2.827	3.954	11
5.0P	0.992	2.786	3.859	9
7.0P	1.270	2.728	3.804	9
10.0P	1.593	2.600	3.712	8
20.0P	2.194	1.867	3.295	5
30.0P	2.463	0.685	2.633	3
40.0P	2.589	-1.025	1.557	2
50.0P	2.134	-3.408	-0.036	1

Note: Drafts are measured at A.P. and F.P along ship's centerline

GZ SUMMARY (Evaluated per IMO (SOLAS'90) Rules for Passenger Ships)
 Available Required

Static Heel Angle	0.0P deg	7.0 deg
Angle at Maximum GZ	39.0P deg	
Maximum GZ	2.606 ft	1.000 ft
Range of Positive GZ	50.0 deg	15.0 deg
Gmt (upright damaged)	12.758 ft	
Righting Area (0.0-22.0)	33.04 ft-deg	2.82 ft-deg

DPRT014A:
 102' CREW BOAT

Damaged Compartments:

TANK ACCESS H2O TANK

	DISPLACEMENT LTons	DRAFT AFT ft	DRAFT FWD ft	TRIM ft	HEEL deg.	UPRIGHT GMT ft
INTACT	107	3.100	4.200	1.100F	0.0	11.300
DAMAGED	108	3.110	4.222	1.112F	0.3S	10.026

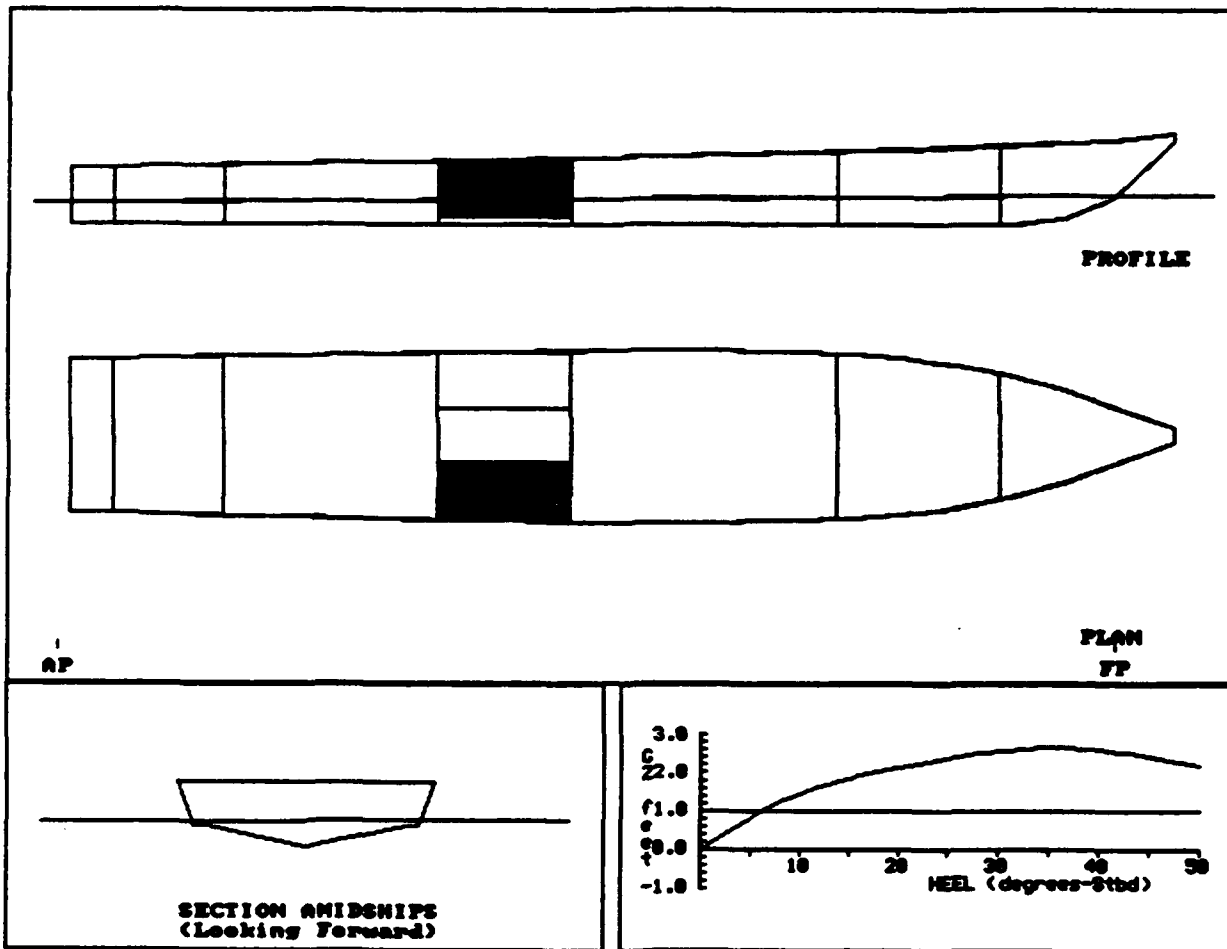

DPRT014A:
 102' CREW BOAT

COMPARTMENT FLOODING SUMMARY

At 0.3oS Heel	PERM.	FLOODED WTR LTons	% FULL (Damaged)	% FULL (Intact)	SP.VOL. ft3/LT	OUTFLOW LTons
TANK ACCESS	0.95	1	FREE	0.0	----	----
H2O TANK	0.95	3	FREE	100.0	34.0000	3
Totals		4				3

INTACT DATA

Draft at AP = 3.100 ft Kmt = 19.160 ft LCG = 58.406A ft-FP
 Draft at FP = 4.200 ft VCG = 7.860 ft LCB = 58.347A ft-FP
 Displacement = 107 LTons GMT = 11.300 ft TCG = 0.000 ft-CL

DRAFT/GZ DATA

HEEL degrees	RIGHTING ARM ft	DRAFT AFT ft	DRAFT FWD ft	FLOODED WATER LTons
0.0	-0.054	3.108	4.222	4
5.0S	0.801	3.146	4.203	6
7.0S	1.102	3.161	4.157	6
10.0S	1.439	3.108	4.104	7
20.0S	2.136	2.650	3.785	10
30.0S	2.566	1.761	3.215	13
40.0S	2.605	0.649	2.244	15
50.0S	2.157	-0.700	0.822	16

Note: Drafts are measured at A.P. and F.P along ship's centerline

GZ SUMMARY (Evaluated per IMO (SOLAS'90) Rules for Passenger Ships)
 Available Required

Static Heel Angle	0.3S deg	7.0 deg
Angle at Maximum GZ	37.0S deg	
Maximum GZ	2.654 ft	1.000 ft
Range of Positive GZ	49.7 deg	15.0 deg
Righting Area (0.3-22.0)	30.25 ft-deg	2.82 ft-deg

RTRN001B: CASE1
 102' CREW BOAT

Damaged Compartments:
 VOID

	DISPLACEMENT LTons	DRAFT AFT ft	DRAFT FWD ft	TRIM ft	HEEL deg.	UPRIGHT GMT ft
INTACT	87	2.830	3.650	0.820F	0.0	12.570
DAMAGED	89	2.737	3.865	1.128F	0.0	13.065

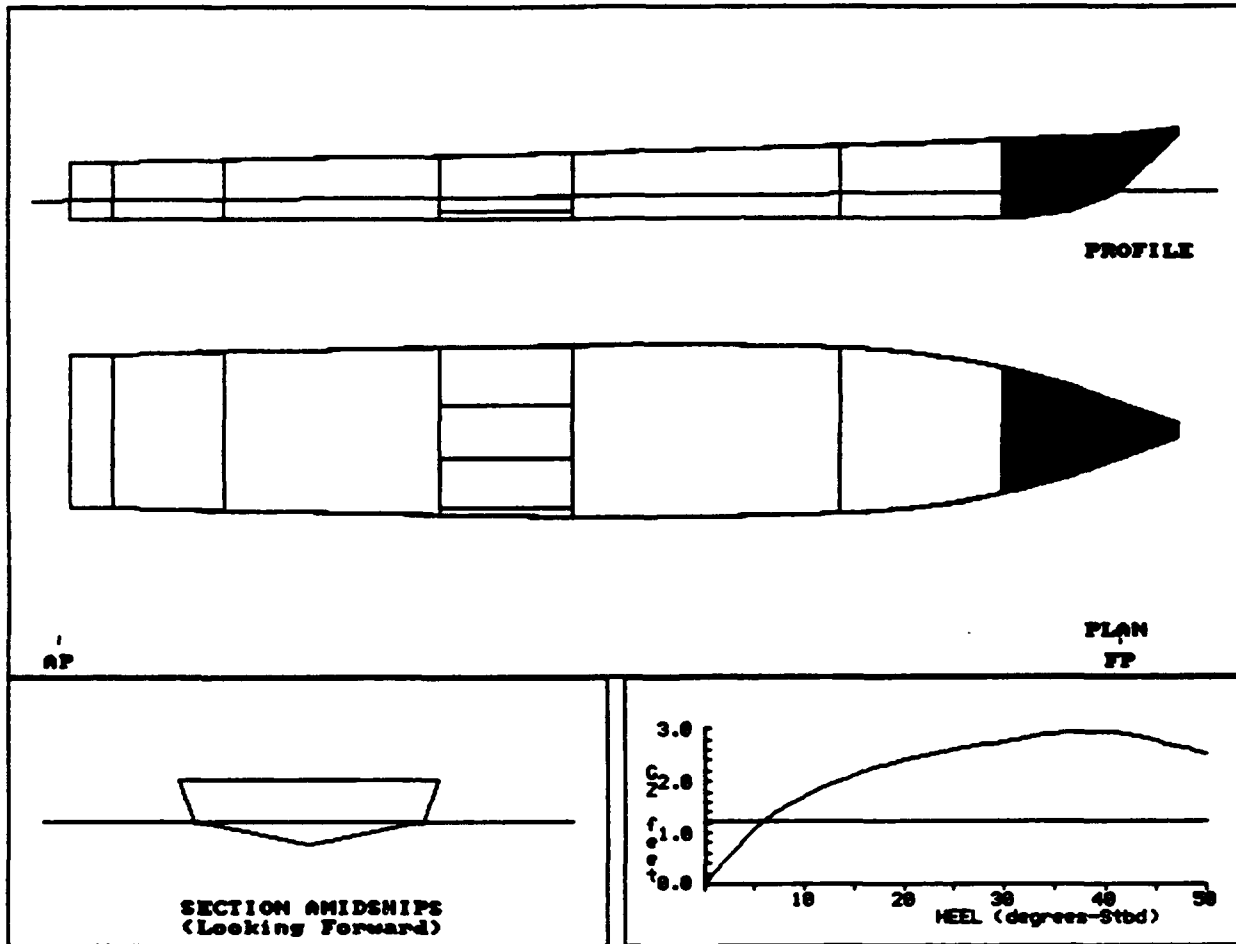

RTRN001B: CASE1
 102' CREW BOAT

COMPARTMENT FLOODING SUMMARY

At 0.0o Heel	PERM.	FLOODED WTR LTons	% FULL (Damaged)	% FULL (Intact)	SP.VOL. ft3/LT	OUTFLOW LTons
VOID	0.95	2	FREE	0.0	----	----
Totals		2				

INTACT DATA

Draft at AP = 2.830 ft	KMt = 20.950 ft	LCG = 59.286A ft-FP
Draft at FP = 3.650 ft	VCG = 8.380 ft	LCB = 59.236A ft-FP
Displacement = 87 LTons	Gmt = 12.570 ft	TCG = 0.000 ft-CL

DRAFT/GZ DATA

HEEL degrees	RIGHTING ARM ft	DRAFT AFT ft	DRAFT FWD ft	FLOODED WATER LTons
0.0	0.000	2.737	3.865	2
5.0S	1.063	2.730	3.788	2
7.0S	1.358	2.685	3.739	2
10.0S	1.710	2.577	3.652	2
20.0S	2.405	1.933	3.228	1
30.0S	2.762	0.866	2.525	1
40.0S	2.945	-0.661	1.365	0
50.0S	2.524	-2.752	-0.343	0

Note: Drafts are measured at A.P. and F.P along ship's centerline

JS SUMMARY (Evaluated per IMO (SOLAS'90) Rules for Passenger Ships)

	Available	Required
Static Heel Angle	0.0 deg	7.0 deg
Angle at Maximum GZ	40.0S deg	
Maximum GZ	2.954 ft	1.210 ft
Range of Positive GZ	50.0 deg	15.0 deg
Gmt (upright damaged)	13.065 ft	
Righting Area (0.0-22.0)	35.78 ft-deg	2.82 ft-deg

RTRN002B: CASE2
 102' CREW BOAT

aged Compartments:
 PASSGRS

	DISPLACEMENT LTons	DRAFT AFT ft	DRAFT FWD ft	TRIM ft	HEEL deg.	UPRIGHT GMT ft
INTACT	87	2.830	3.650	0.820F	0.0	12.570
DAMAGED	100	2.393	4.836	2.443F	0.0	13.618

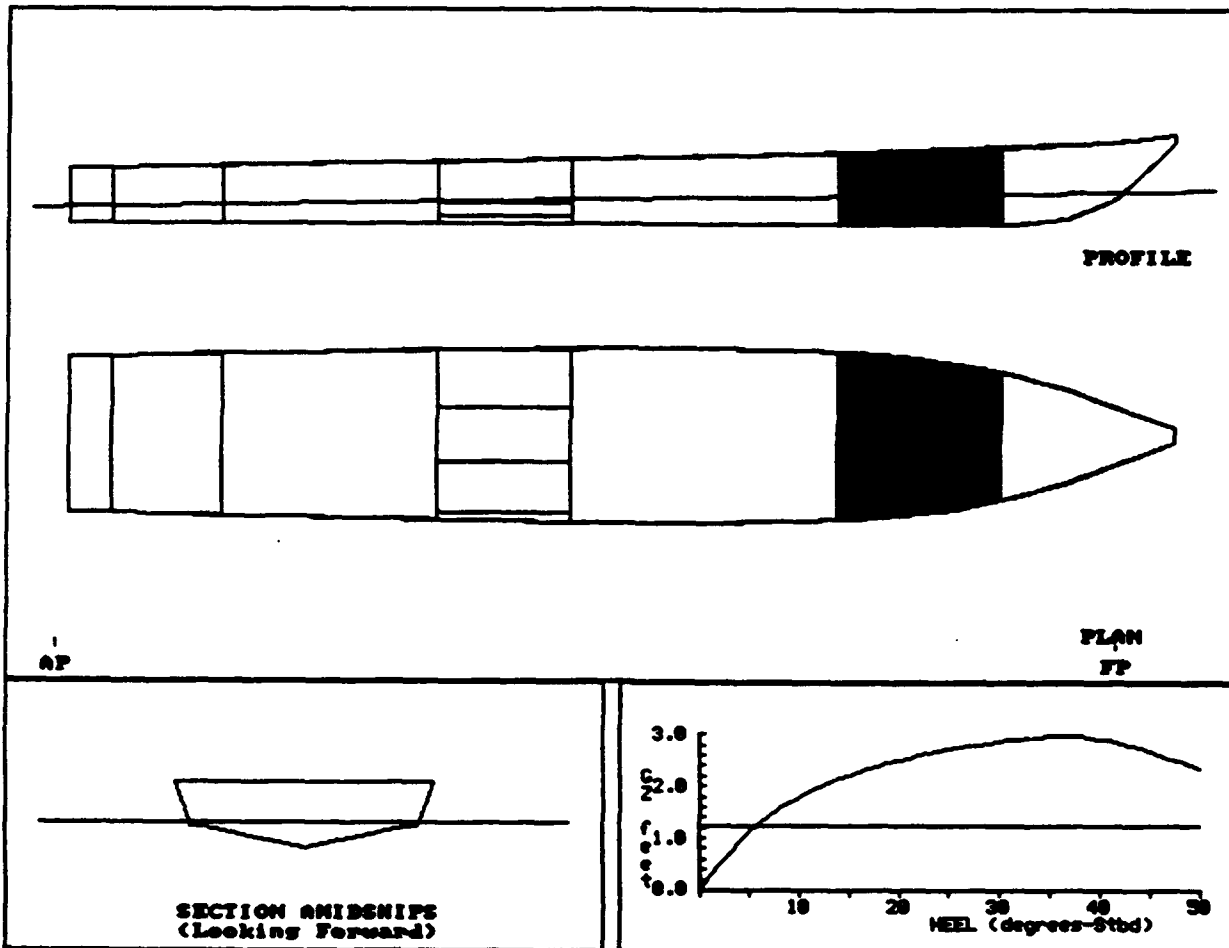

RTRN002B: CASE2
 102' CREW BOAT

COMPARTMENT FLOODING SUMMARY

At 0.0o Heel	PERM.	FLOODED WTR LTons	% FULL (Damaged)	% FULL (Intact)	SP.VOL. ft3/LT	OUTFLOW LTons
PASSGRS	0.95	13	FREE	0.0	----	----
Totals		13				

INTACT DATA

Draft at AP = 2.830 ft	KMT = 20.950 ft	LCG = 59.286A ft-FP
Draft at FP = 3.650 ft	VCG = 8.380 ft	LCB = 59.236A ft-FP
Displacement = 87 LTons	Gmt = 12.570 ft	TCG = 0.000 ft-CL

DRAFT/GZ DATA

HEEL degrees	RIGHTING ARM ft	DRAFT AFT ft	DRAFT FWD ft	FLOODED WATER LTons
0.0	0.000	2.393	4.836	13
5.0S	1.114	2.373	4.800	13
7.0S	1.419	2.322	4.767	13
10.0S	1.781	2.193	4.722	13
20.0S	2.495	1.513	4.377	13
30.0S	2.861	0.398	3.767	12
40.0S	2.917	-1.261	2.923	13
50.0S	2.341	-3.653	1.945	14

Note: Drafts are measured at A.P. and F.P along ship's centerline

JZ SUMMARY (Evaluated per IMO (SOLAS'90) Rules for Passenger Ships)
 Available Required

Static Heel Angle	0.0 deg	7.0 deg
Angle at Maximum GZ	37.0S deg	
Maximum GZ	2.966 ft	1.210 ft
Range of Positive GZ	50.0 deg	15.0 deg
Gmt (upright damaged)	13.618 ft	
Righting Area (0.0-22.0)	37.22 ft-deg	2.82 ft-deg

RTRN003B: CASE3
 102' CREW BOAT

Damaged Compartments:
 CREW

	DISPLACEMENT LTons	DRAFT AFT ft	DRAFT FWD ft	TRIM ft	HEEL deg.	UPRIGHT GMT ft
INTACT	87	2.830	3.650	0.820F	0.0	12.570
DAMAGED	124	2.660	5.511	2.851F	0.0	9.571

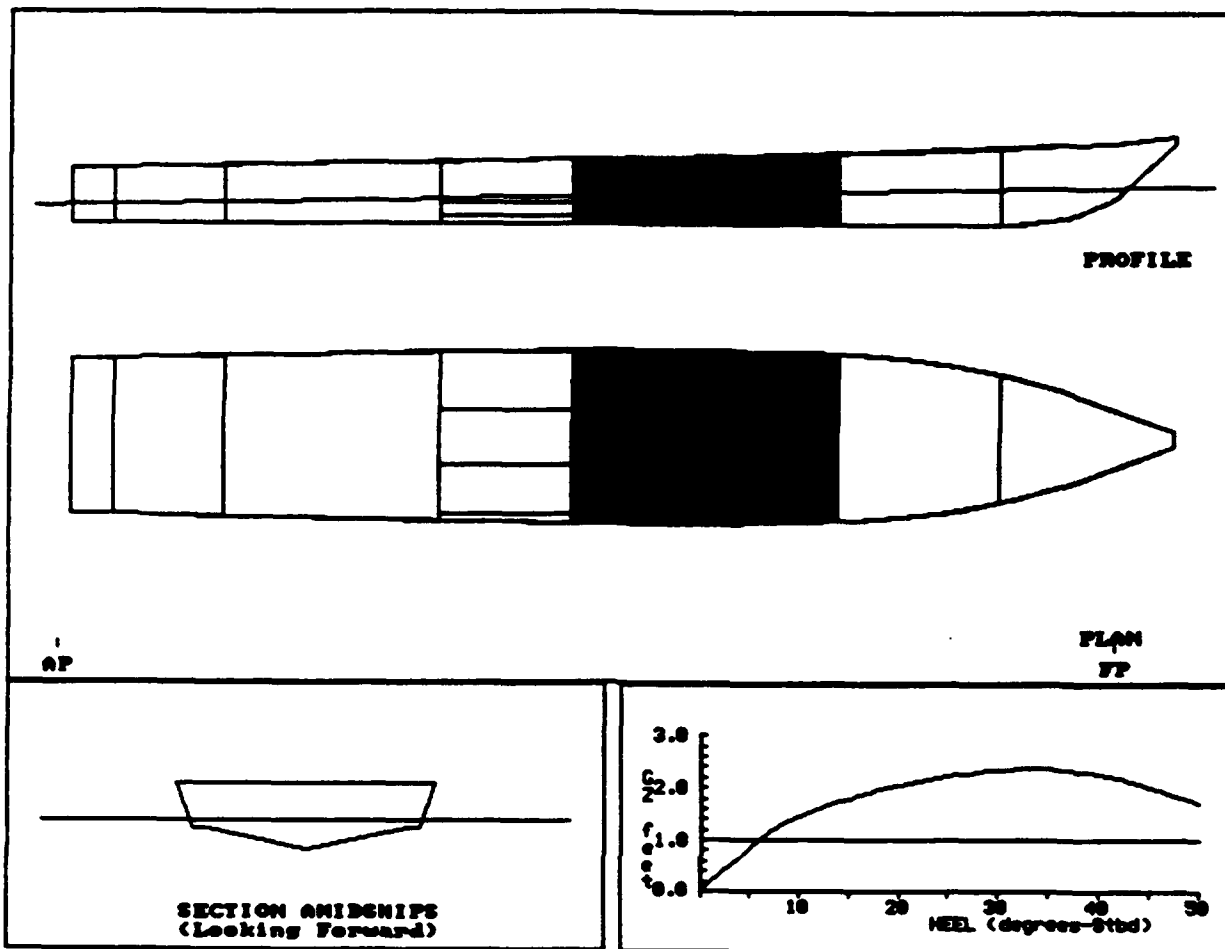

RTRN003B: CASE3
 102' CREW BOAT

COMPARTMENT FLOODING SUMMARY

At 0.0o Heel	PERM.	FLOODED WTR LTons	% FULL (Damaged)	% FULL (Intact)	SP.VOL. ft3/LT	OUTFLOW LTons
CREW	0.95	37	FREE	0.0	----	----
Totals		37				

INTACT DATA

Draft at AP = 2.830 ft KMT = 20.950 ft LCG = 59.286A ft-FP
 Draft at FP = 3.650 ft VCG = 8.380 ft LCB = 59.236A ft-FP
 Displacement = 87 LTons GMT = 12.570 ft TCG = 0.000 ft-CL

DRAFT/GZ DATA

HEEL degrees	RIGHTING ARM ft	DRAFT AFT ft	DRAFT FWD ft	FLOODED WATER LTons
0.0	0.000	2.660	5.511	37
5.0S	0.837	2.655	5.492	37
7.0S	1.135	2.631	5.479	37
10.0S	1.448	2.544	5.439	38
20.0S	2.043	1.930	5.232	39
30.0S	2.343	0.883	4.784	40
40.0S	2.263	-0.540	4.110	41
50.0S	1.710	-2.453	3.279	40

Note: Drafts are measured at A.P. and F.P along ship's centerline

GZ SUMMARY (Evaluated per IMO (SOLAS'90) Rules for Passenger Ships)
 Available Required

Static Heel Angle	0.0 deg	7.0 deg
Angle at Maximum GZ	35.0S deg	
Maximum GZ	2.370 ft	1.000 ft
Range of Positive GZ	50.0 deg	15.0 deg
Gmt (upright damaged)	9.571 ft	
Righting Area (0.0-22.0)	29.98 ft-deg	2.82 ft-deg

RTRN004B: CASE4
 102' CREW BOAT

Imaged Compartments:
 ENGRoom

	DISPLACEMENT LTons	DRAFT AFT ft	DRAFT FWD ft	TRIM ft	HEEL deg.	UPRIGHT Gmt ft
INTACT	87	2.830	3.650	0.820F	0.0	12.570
DAMAGED	115	4.053	3.284	0.769A	0.0	9.250

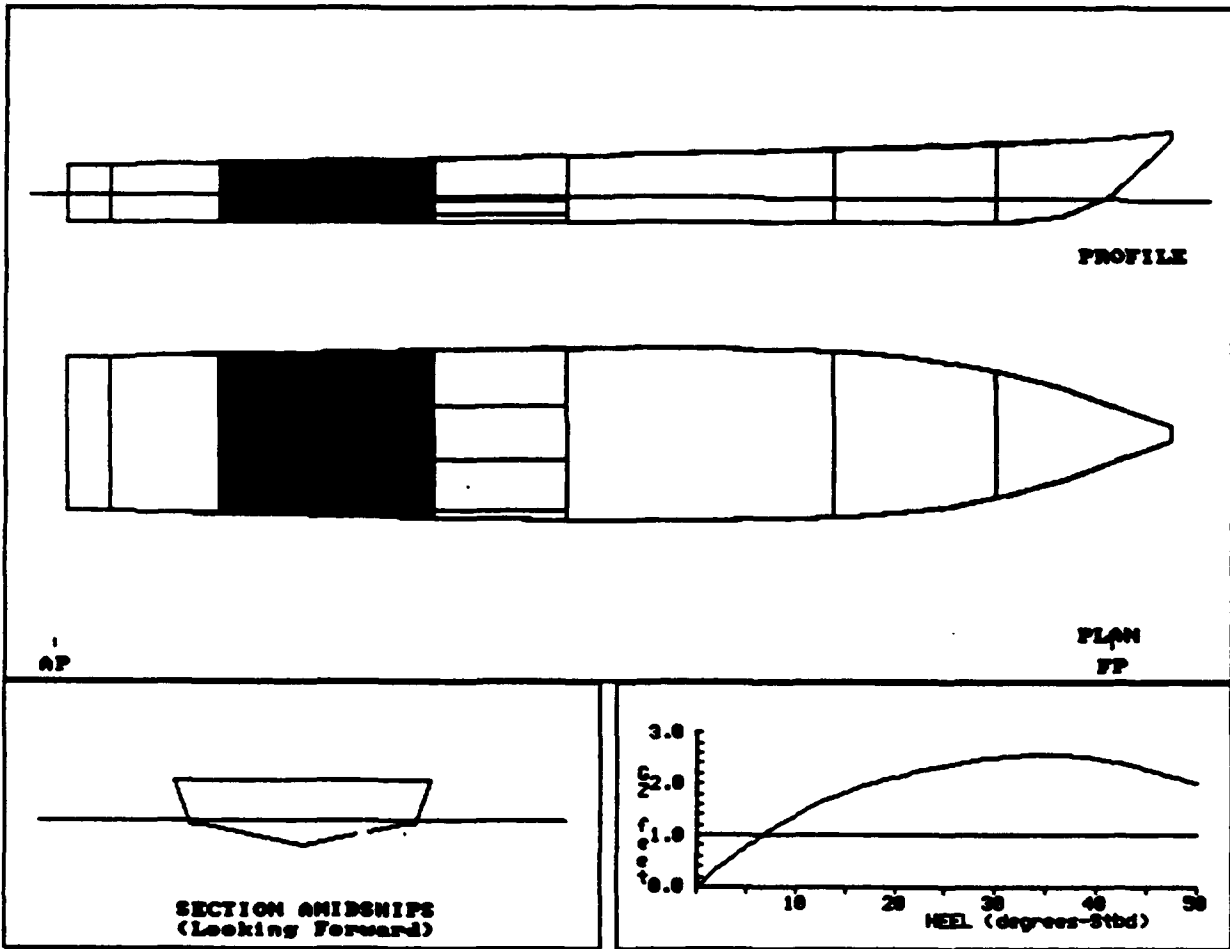

RTRN004B: CASE4
 102' CREW BOAT

COMPARTMENT FLOODING SUMMARY

At 0.0o Heel	PERM.	FLOODED WTR LTons	% FULL (Damaged)	% FULL (Intact)	SP.VOL. ft3/LT	OUTFLOW LTons
ENGROOM	0.85	28	FREE	0.0	----	----
Totals		28				

INTACT DATA

Draft at AP = 2.830 ft	KMT = 20.950 ft	LCG = 59.286A ft-FP
Draft at FP = 3.650 ft	VCG = 8.380 ft	LCB = 59.236A ft-FP
Displacement = 87 LTons	GMT = 12.570 ft	TCG = 0.000 ft-CL

DRAFT/GZ DATA

HEEL degrees	RIGHTING ARM ft	DRAFT AFT ft	DRAFT FWD ft	FLOODED WATER LTons
0.0	0.000	4.053	3.284	28
5.0S	0.764	4.048	3.231	28
7.0S	1.034	4.041	3.178	28
10.0S	1.386	4.014	3.067	28
20.0S	2.123	3.617	2.579	28
30.0S	2.505	2.810	1.817	28
40.0S	2.489	1.902	0.508	28
50.0S	1.999	0.908	-1.530	28

Note: Drafts are measured at A.P. and F.P along ship's centerline

GZ SUMMARY (Evaluated per IMO (SOLAS'90) Rules for Passenger Ships)
 Available Required

Static Heel Angle	0.0 deg	7.0 deg
Angle at Maximum GZ	36.0S deg	
Maximum GZ	2.562 ft	1.000 ft
Range of Positive GZ	50.0 deg	15.0 deg
Gmt (upright damaged)	9.250 ft	
Righting Area (0.0-22.0)	29.72 ft-deg	2.82 ft-deg

RTRN005B: CASE5
 102' CREW BOAT

Managed Compartments:
 MAX ER

	DISPLACEMENT LTons	DRAFT AFT ft	DRAFT FWD ft	TRIM ft	HEEL deg.	UPRIGHT GMT ft
INTACT	87	2.830	3.650	0.820F	0.0	12.570
DAMAGED	99	3.660	3.101	0.559A	0.0	10.658

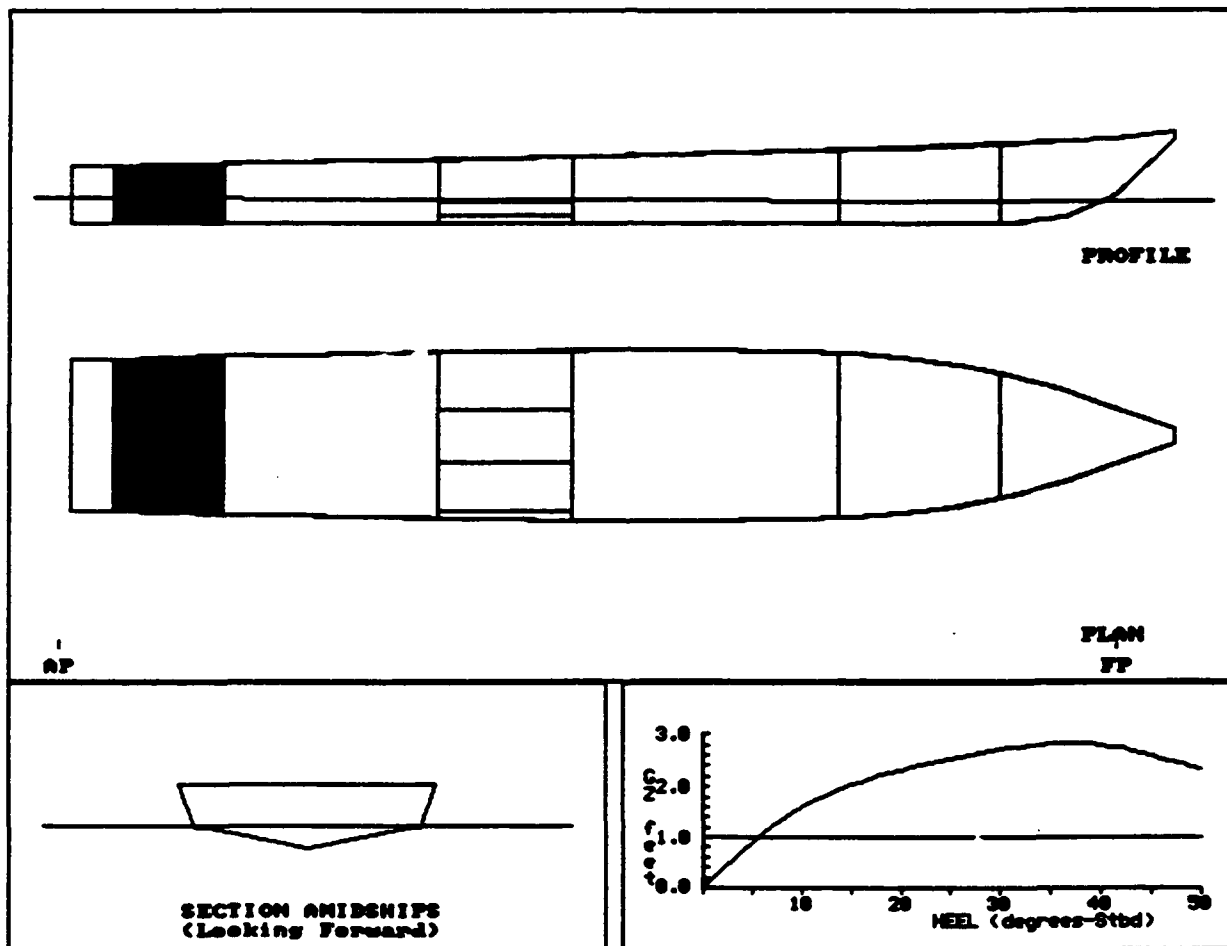

RTRN005B: CASES
 102' CREW BOAT

COMPARTMENT FLOODING SUMMARY

At 0.0o Heel	PERM.	FLOODED WTR LTons	% FULL (Damaged)	% FULL (Intact)	SP.VOL. ft3/LT	OUTFLOW LTons
AUX ER	0.85	13	FREE	0.0	----	----
Totals		13				

INTACT DATA

Draft at AP = 2.830 ft	KMT = 20.950 ft	LCG = 59.286A ft-FP
Draft at FP = 3.650 ft	VCG = 8.380 ft	LCB = 59.236A ft-FP
Displacement = 87 LTons	GMT = 12.570 ft	TCG = 0.000 ft-CL

DRAFT/GZ DATA

HEEL degrees	RIGHTING ARM ft	DRAFT AFT ft	DRAFT FWD ft	FLOODED WATER LTons
0.0	0.000	3.660	3.101	13
5.0S	0.905	3.663	3.027	13
7.0S	1.213	3.653	2.965	13
10.0S	1.587	3.601	2.853	13
20.0S	2.321	3.076	2.391	12
30.0S	2.714	2.089	1.687	12
40.0S	2.796	0.829	0.467	11
50.0S	2.324	-0.586	-1.597	11

Note: Drafts are measured at A.P. and F.P along ship's centerline

GZ SUMMARY (Evaluated per IMO (SOLAS'90) Rules for Passenger Ships)

	Available	Required
Static Heel Angle	0.0 deg	7.0 deg
Angle at Maximum GZ	38.0S deg	
Maximum GZ	2.830 ft	1.000 ft
Range of Positive GZ	50.0 deg	15.0 deg
Gmt (upright damaged)	10.658 ft	
Righting Area (0.0-22.0)	33.42 ft-deg	2.82 ft-deg

RTRM006B: CASE6
 102' CREW BOAT

Imaged Compartments:
 LAZARETTE

	DISPLACEMENT LTons	DRAFT AFT ft	DRAFT FWD ft	TRIM ft	HEEL deg.	UPRIGHT Gmt ft
INTACT	87	2.830	3.650	0.820F	0.0	12.570
DAMAGED	91	3.178	3.387	0.209F	0.0	11.723

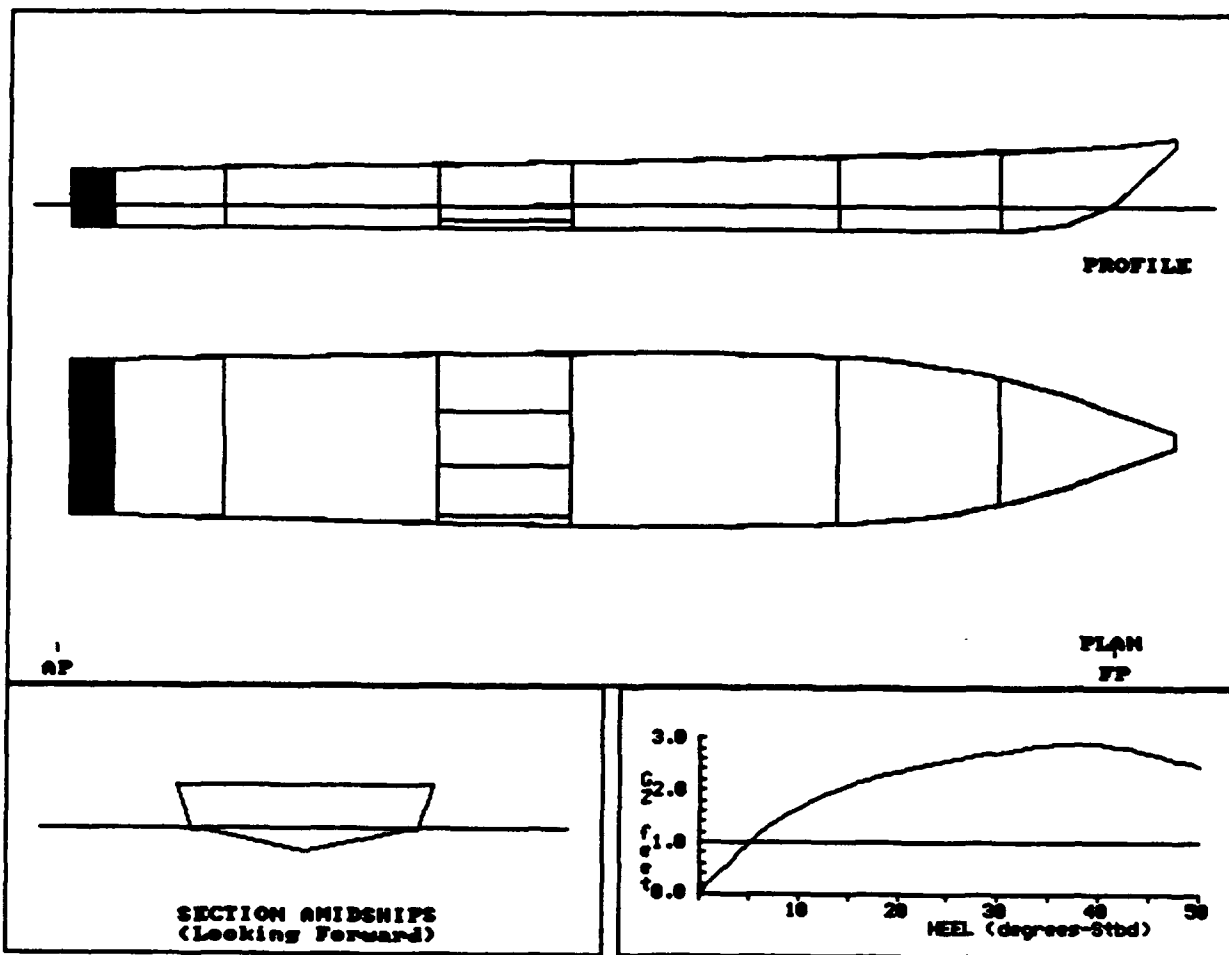

RTRN006B: CASE6
 102' CREW BOAT

COMPARTMENT FLOODING SUMMARY

At 0.0o Heel	PERM.	FLOODED WTR LTons	% FULL (Damaged)	% FULL (Intact)	SP.VOL. ft3/LT	OUTFLOW LTons
LAZARETTE	0.95	5	FREE	0.0	----	----
Totals		5				

INTACT DATA

Draft at AP = 2.830 ft	KMt = 20.950 ft	LCG = 59.286A ft-FP
Draft at FP = 3.650 ft	VCG = 8.380 ft	LCB = 59.236A ft-FP
Displacement = 87 LTons	GMT = 12.570 ft	TCG = 0.000 ft-CL

DRAFT/GZ DATA

HEEL degrees	RIGHTING ARM ft	DRAFT AFT ft	DRAFT FWD ft	FLOODED WATER LTons
0.0	0.000	3.178	3.387	5
5.0S	0.983	3.176	3.312	5
7.0S	1.297	3.154	3.253	5
10.0S	1.653	3.065	3.159	5
20.0S	2.360	2.458	2.740	4
30.0S	2.732	1.397	2.078	4
40.0S	2.892	-0.060	0.941	4
50.0S	2.461	-1.891	-0.893	4

Note: Drafts are measured at A.P. and F.P along ship's centerline

GZ SUMMARY (Evaluated per IMO (SOLAS'90) Rules for Passenger Ships)
 Available Required

Static Heel Angle	0.0 deg	7.0 deg
Angle at Maximum GZ	39.0S deg	
Maximum GZ	2.906 ft	1.000 ft
Range of Positive GZ	50.0 deg	15.0 deg
Gmt (upright damaged)	11.723 ft	
Righting Area (0.0-22.0)	34.58 ft-deg	2.82 ft-deg

RTRN007B:
102' CREW BOAT

Damaged Compartments:
 TANK ACCESS FO TANK

	DISPLACEMENT LTons	DRAFT AFT ft	DRAFT FWD ft	TRIM ft	HEEL deg.	UPRIGHT GNT ft
INTACT	87	2.830	3.650	0.820F	0.0	12.570
DAMAGED	92	2.943	3.763	0.820F	0.0S	11.586

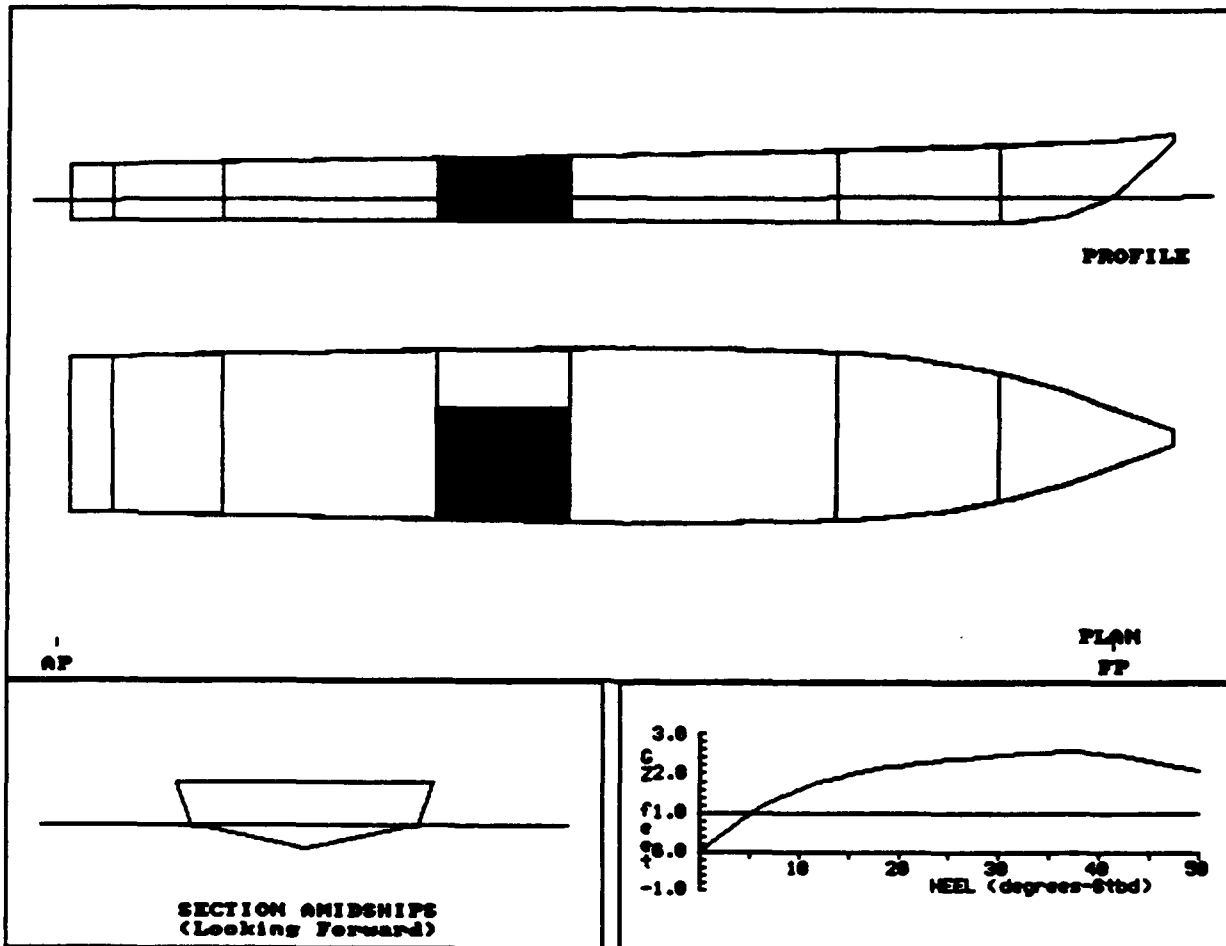

RTRN007B:
 102' CREW BOAT

COMPARTMENT FLOODING SUMMARY

At 0.0oS Heel	PERM.	FLOODED WTR LTons	% FULL (Damaged)	% FULL (Intact)	SP.VOL. ft ³ /LT	OUTFLOW LTons
TANK ACCESS	0.95	0	FREE	0.0	----	----
FO TANK	0.95	8	FREE	10.0	40.6000	2
Totals		8				2

INTACT DATA

Draft at AP = 2.830 ft	KMT = 20.950 ft	LCG = 59.286A ft-FP
Draft at FP = 3.650 ft	VCG = 8.380 ft	LCB = 59.236A ft-FP
Displacement = 87 LTons	GMT = 12.570 ft	TCG = 0.000 ft-CL

DRAFT/GZ DATA

HEEL degrees	RIGHTING ARM ft	DRAFT AFT ft	DRAFT FWD ft	FLOODED WATER LTons
0.0	-0.009	2.943	3.763	8
5.0S	0.955	2.975	3.728	10
7.0S	1.250	2.971	3.672	10
10.0S	1.582	2.883	3.619	11
20.0S	2.195	2.314	3.255	12
30.0S	2.459	1.288	2.623	13
40.0S	2.519	-0.134	1.553	13
50.0S	2.063	-1.978	-0.049	13

Note: Drafts are measured at A.P. and F.P along ship's centerline

GZ SUMMARY (Evaluated per IMO (SOLAS'90) Rules for Passenger Ships)
 Available Required

Static Heel Angle	0.0S deg	7.0 deg
Angle at Maximum GZ	38.0S deg	
Maximum GZ	2.551 ft	1.000 ft
Range of Positive GZ	50.0 deg	15.0 deg
Gmt (upright damaged)	11.586 ft	
Righting Area (0.0-22.0)	32.74 ft-deg	2.82 ft-deg

RTRN008B:
 102' CREW BOAT

Imaged Compartments:

	TANK ACCESS	N2O TANK	FO TANK			
	DISPLACEMENT	DRAFT AFT	DRAFT FWD	TRIM	HEEL	UPRIGHT GMT
	Ltons	ft	ft	ft	deg.	ft
INTACT	87	2.830	3.650	0.820F	0.0	12.570
DAMAGED	96	3.013	3.814	0.802F	1.2S	11.920

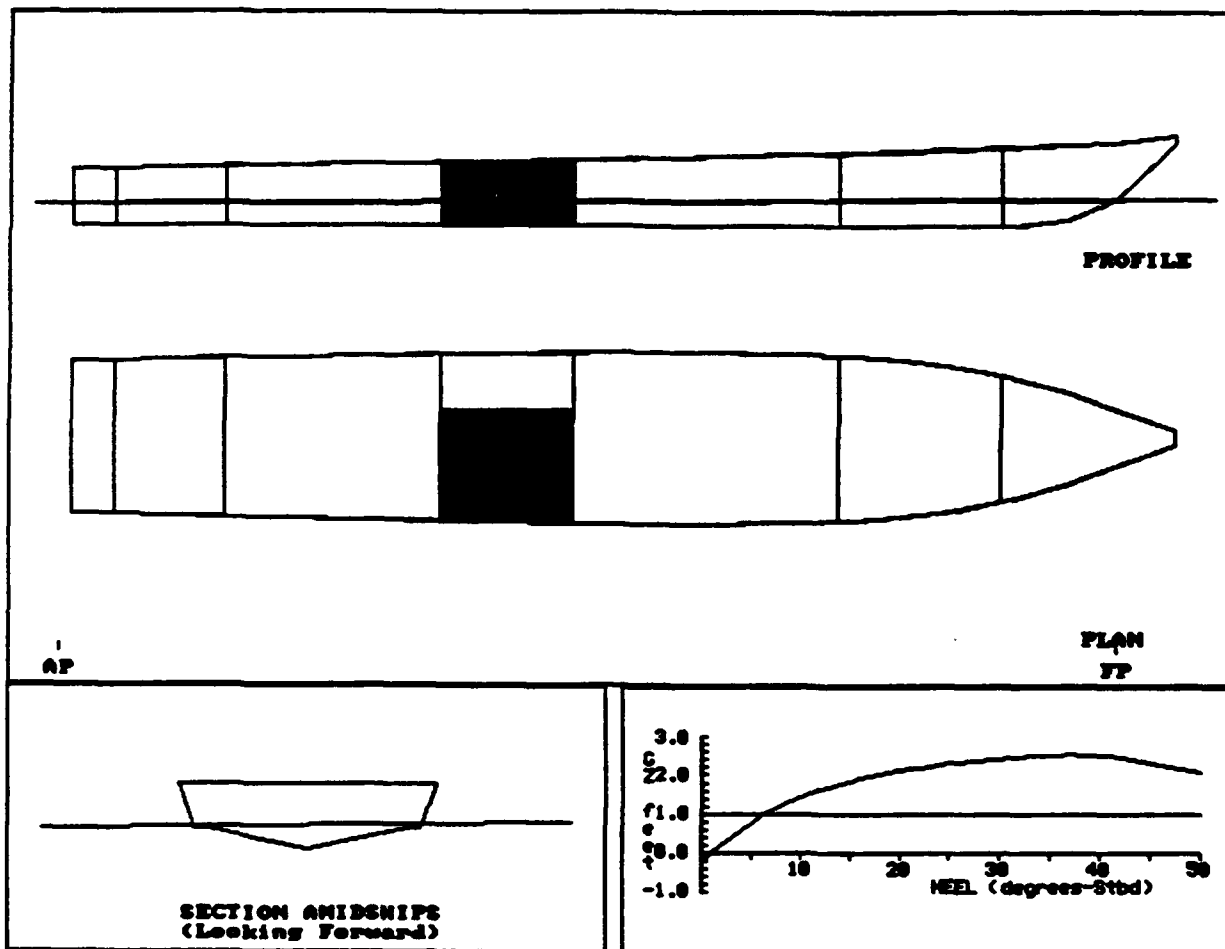

RTRN008B:
 102' CREW BOAT

COMPARTMENT FLOODING SUMMARY

At 1.2oS Heel	PERM.	FLOODED WTR LTons	% FULL (Damaged)	% FULL (Intact)	SP.VOL. ft3/LT	OUTFLOW LTons
TANK ACCESS	0.95	1	FREE	0.0	----	----
H2O TANK	0.95	3	FREE	10.0	34.0000	0
FO TANK	0.95	8	FREE	10.0	40.6000	2
Totals		12				2

INTACT DATA

Draft at AP = 2.830 ft KMT = 20.950 ft LCG = 59.286A ft-FP
 Draft at FP = 3.650 ft VCG = 8.380 ft LCB = 59.236A ft-FP
 Displacement = 87 LTons GMT = 12.570 ft TCG = 0.000 ft-CL

DRAFT/GZ DATA

HEEL degrees	RIGHTING ARM ft	DRAFT AFT ft	DRAFT FWD ft	FLOODED WATER LTons
0.0	-0.242	3.005	3.816	11
5.0S	0.753	3.036	3.789	13
7.0S	1.071	3.039	3.732	13
10.0S	1.427	2.958	3.678	14
20.0S	2.111	2.407	3.316	16
30.0S	2.434	1.396	2.685	16
40.0S	2.519	0.015	1.615	16
50.0S	2.085	-1.753	0.031	16

Note: Drafts are measured at A.P. and F.P along ship's centerline

GZ SUMMARY (Evaluated per IMO (SOLAS'90) Rules for Passenger Ships)
 Available Required

Static Heel Angle	1.2S deg	7.0 deg
Angle at Maximum GZ	38.0S deg	
Maximum GZ	2.545 ft	1.000 ft
Range of Positive GZ	48.8 deg	15.0 deg
Righting Area (1.2-22.0)	29.56 ft-deg	2.82 ft-deg

RTRN009B:
 102' CREW BOAT

Imaged Compartments:
 TANK ACCESS

	DISPLACEMENT LTons	DRAFT AFT ft	DRAFT FWD ft	TRIM ft	HEEL deg.	UPRIGHT Gmt ft
INTACT	87	2.830	3.650	0.820F	0.0	12.570
DAMAGED	87	2.830	3.650	0.820F	0.0	11.772

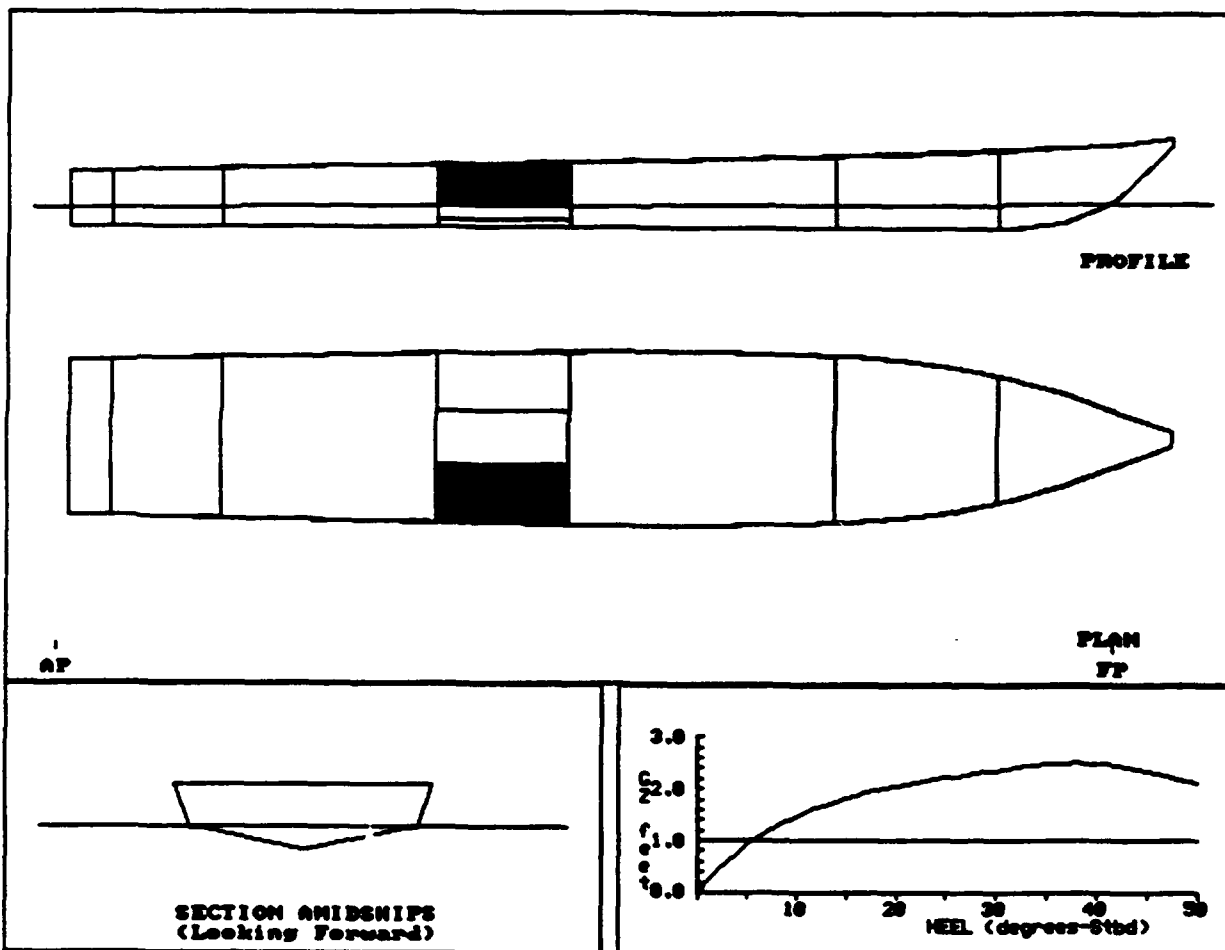

RTRN009B:
 102' CREW BOAT

COMPARTMENT FLOODING SUMMARY

At 0.0o Heel	PERM.	FLOODED WTR LTons	% FULL (Damaged)	% FULL (Intact)	SP.VOL. ft3/LT	OUTFLOW LTons
TANK ACCESS	0.95	0	FREE	0.0	----	----
Totals		0				

INTACT DATA

Draft at AP = 2.830 ft	Kmt = 20.950 ft	LCG = 59.286A ft-FP
Draft at FP = 3.650 ft	VCG = 8.380 ft	LCB = 59.236A ft-FP
Displacement = 87 LTons	Gmt = 12.570 ft	TCG = 0.000 ft-CL

DRAFT/GZ DATA

HEEL degrees	RIGHTING ARM ft	DRAFT AFT ft	DRAFT FWD ft	FLOODED WATER LTons
0.0	0.000	2.830	3.650	0
5.0S	0.913	2.856	3.603	1
7.0S	1.167	2.826	3.571	2
10.0S	1.463	2.744	3.505	3
20.0S	2.042	2.187	3.168	6
30.0S	2.357	1.212	2.577	8
40.0S	2.500	-0.150	1.544	10
50.0S	2.112	-1.904	-0.024	12

Note: Drafts are measured at A.P. and F.P along ship's centerline

GZ SUMMARY (Evaluated per IMO (SOLAS'90) Rules for Passenger Ships)

	Available	Required
Static Heel Angle	0.0 deg	7.0 deg
Angle at Maximum GZ	39.0S deg	
Maximum GZ	2.512 ft	1.000 ft
Range of Positive GZ	50.0 deg	15.0 deg
Gmt (upright damaged)	11.772 ft	
Righting Area (0.0-22.0)	30.53 ft-deg	2.82 ft-deg

RTRN010B:
 102' CREW BOAT

Damaged Compartments:
 FO TANK

	DISPLACEMENT LTons	DRAFT AFT ft	DRAFT FWD ft	TRIM ft	HEEL deg.	UPRIGHT GMT ft
INTACT	87	2.830	3.650	0.820F	0.0	12.570
DAMAGED	92	2.942	3.759	0.817F	0.0	13.420

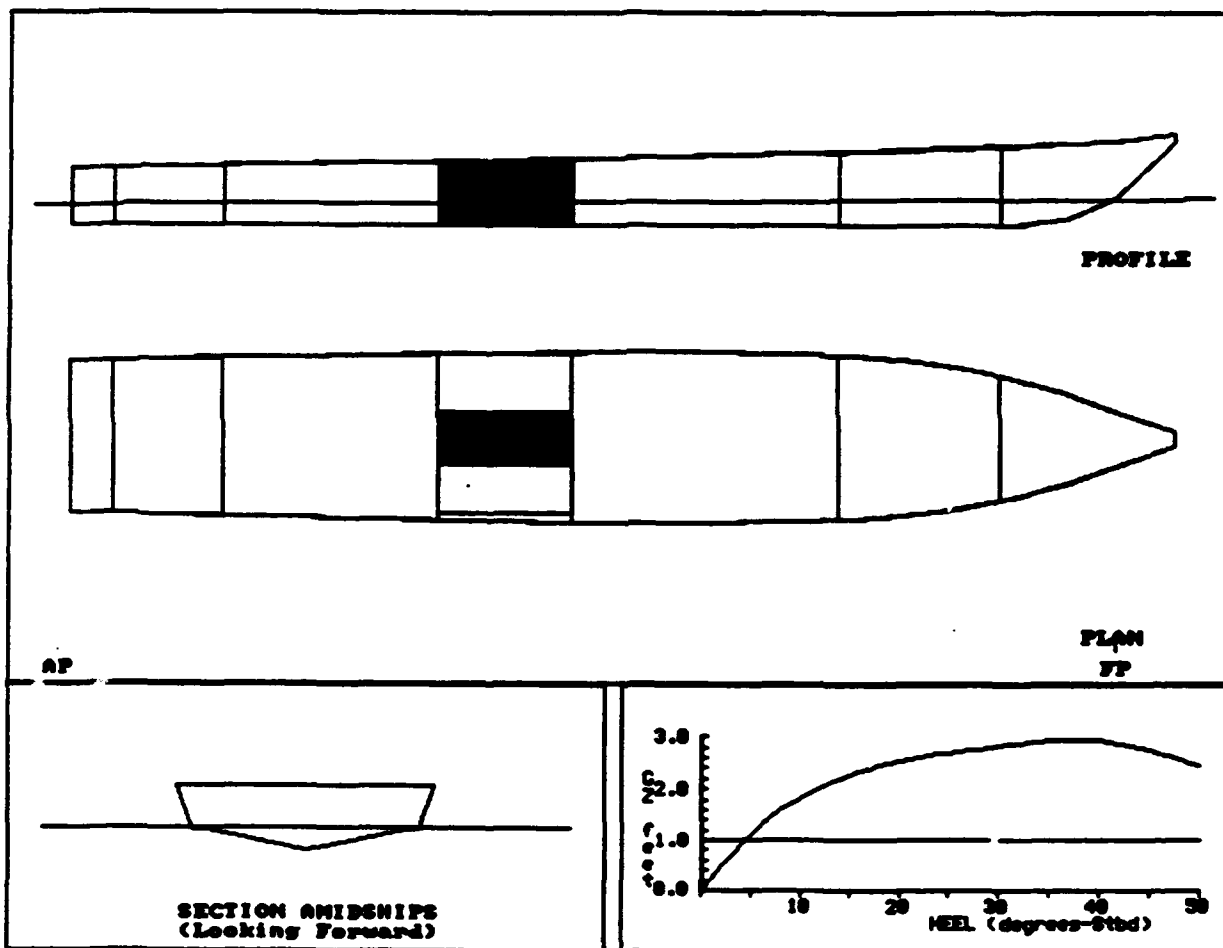

RTRN010B:
 102' CREW BOAT

COMPARTMENT FLOODING SUMMARY

At 0.0o Heel	PERM.	FLOODED WTR LTons	% FULL (Damaged)	% FULL (Intact)	SP.VOL. ft ³ /LT	OUTFLOW LTons
FO TANK	0.95	8	FREE	10.0	40.6000	2
Totals		8				2

INTACT DATA

Draft at AP = 2.830 ft	KMT = 20.950 ft	LCG = 59.286A ft-FP
Draft at FP = 3.650 ft	VCG = 8.380 ft	LCB = 59.236A ft-FP
Displacement = 87 LTons	GMT = 12.570 ft	TCG = 0.000 ft-CL

DRAFT/GZ DATA

HEEL degrees	RIGHTING ARM ft	DRAFT AFT ft	DRAFT FWD ft	FLOODED WATER LTons
0.0	0.000	2.942	3.759	8
5.0S	1.111	2.936	3.690	8
7.0S	1.444	2.901	3.637	8
10.0S	1.824	2.796	3.548	7
20.0S	2.526	2.121	3.122	6
30.0S	2.819	0.976	2.436	4
40.0S	2.932	-0.654	1.317	2
50.0S	2.451	-2.859	-0.382	1

Note: Drafts are measured at A.P. and F.P along ship's centerline

GZ SUMMARY (Evaluated per IMO (SOLAS'90) Rules for Passenger Ships)

	Available	Required
Static Heel Angle	0.0 deg	7.0 deg
Angle at Maximum GZ	39.0S deg	
Maximum GZ	2.954 ft	1.000 ft
Range of Positive GZ	50.0 deg	15.0 deg
Gmt (upright damaged)	13.420 ft	
Righting Area (0.0-22.0)	37.81 ft-deg	2.82 ft-deg

RTRM011B:
 102' CREW BOAT

Damaged Compartments:
 TANK VOID

	DISPLACEMENT LTONS	DRAFT AFT ft	DRAFT FWD ft	TRIM ft	HEEL deg.	UPRIGHT GMT ft
INTACT	87	2.830	3.650	0.820F	0.0	12.570
DAMAGED	90	2.900	3.701	0.801F	1.2P	11.164

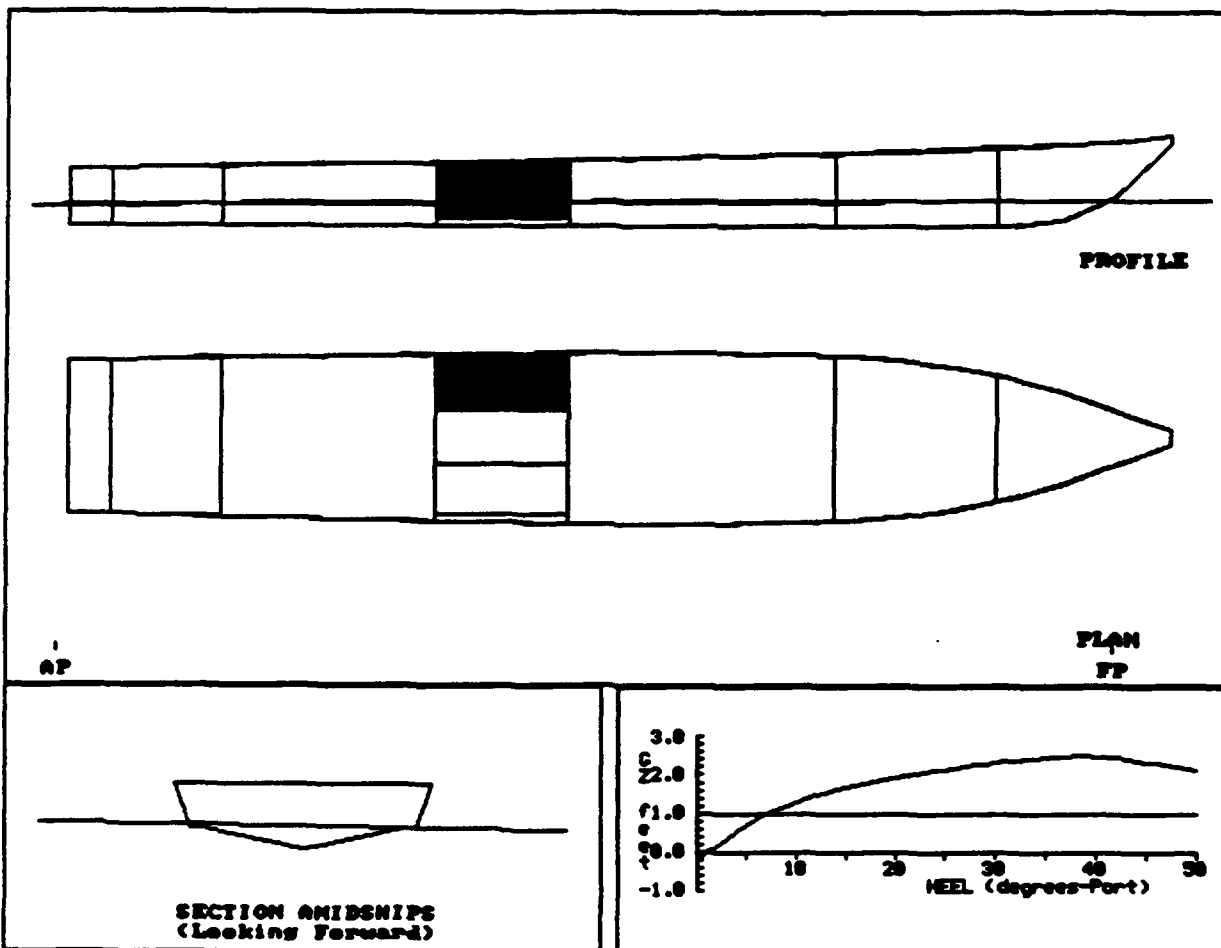

RTRN011B:
 102' CREW BOAT

COMPARTMENT FLOODING SUMMARY

At 1.20P Heel	PERM.	FLOODED WTR LTons	% FULL (Damaged)	% FULL (Intact)	SP.VOL. ft3/LT	OUTFLOW LTons
TANK VOID	0.95	3	FREE	0.0	----	----
Totals		3				

INTACT DATA

Draft at AP = 2.830 ft	KMt = 20.950 ft	LCG = 59.286A ft-FP
Draft at FP = 3.650 ft	VCG = 8.380 ft	LCB = 59.236A ft-FP
Displacement = 87 LTons	GMT = 12.570 ft	TCG = 0.000 ft-CL

DRAFT/GZ DATA

HEEL degrees	RIGHTING ARM ft	DRAFT AFT ft	DRAFT FWD ft	FLOODED WATER LTons
0.0	-0.231	2.890	3.709	3
5.0P	0.698	2.922	3.670	5
7.0P	0.975	2.900	3.634	5
10.0P	1.294	2.824	3.569	6
20.0P	1.940	2.286	3.232	9
30.0P	2.318	1.328	2.642	12
40.0P	2.488	0.009	1.610	14
50.0P	2.126	-1.664	0.060	15

Note: Drafts are measured at A.P. and F.P along ship's centerline

GZ SUMMARY (Evaluated per IMO (SOLAS'90) Rules for Passenger Ships)
 Available Required

Static Heel Angle	1.2P deg	7.0 deg
Angle at Maximum GZ	39.0P deg	
Maximum GZ	2.496 ft	1.000 ft
Range of Positive GZ	48.8 deg	15.0 deg
Righting Area (1.2-22.0)	27.02 ft-deg	2.82 ft-deg

RTRM012B:
 102' CREW BOAT

Damaged Compartments:
 FO TANK TANK VOID

	DISPLACEMENT LTons	DRAFT AFT ft	DRAFT FWD ft	TRIM ft	HEEL deg.	UPRIGHT GMT ft
INTACT	87	2.830	3.650	0.820F	0.0	12.570
DAMAGED	96	3.021	3.821	0.800F	1.3P	11.912

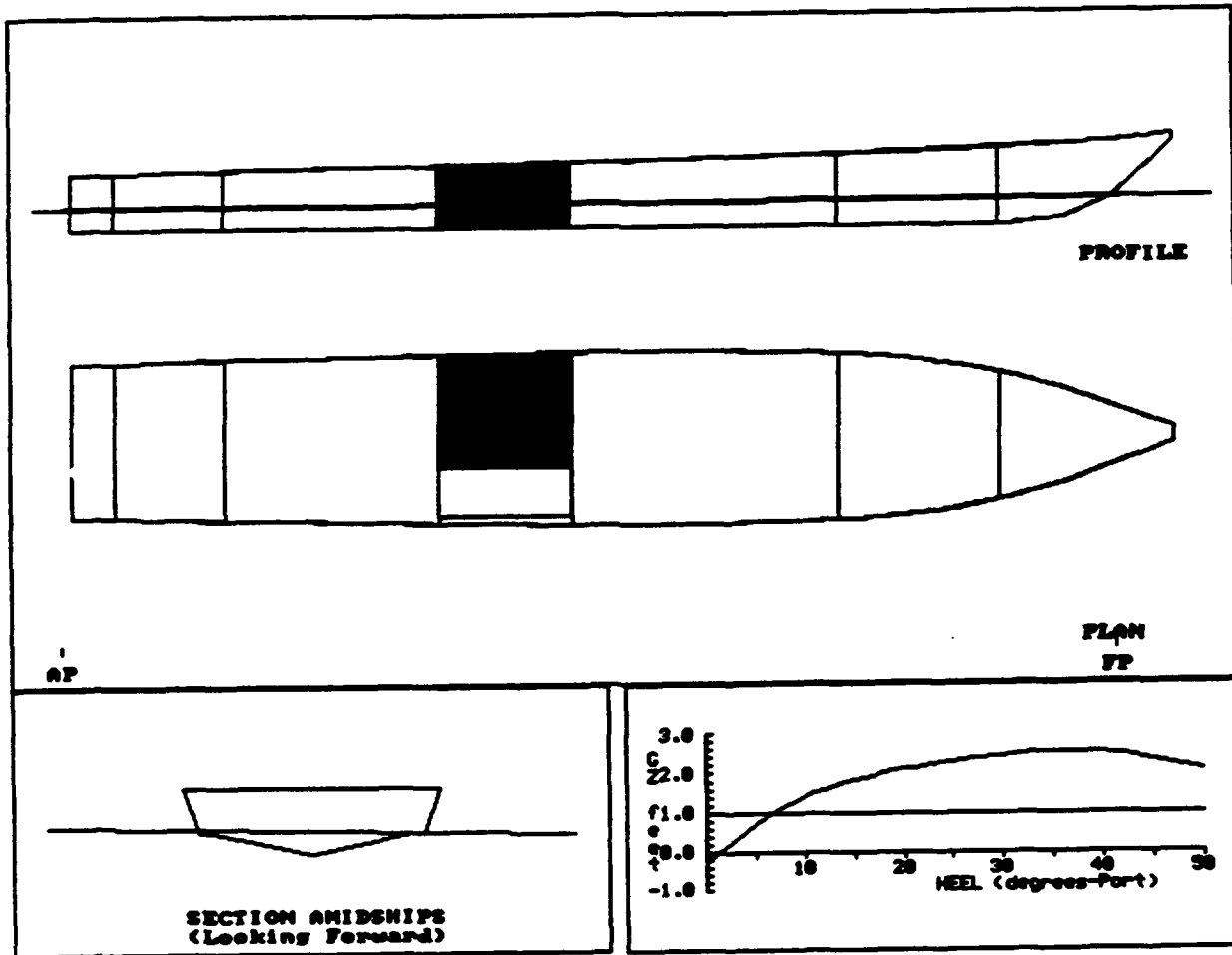

RTRM012B:
 102' CREW BOAT

COMPARTMENT FLOODING SUMMARY

At 1.30P Heel	PERM.	FLOODED WTR LTons	% FULL (Damaged)	% FULL (Intact)	SP.VOL. ft3/LT	OUTFLOW LTons
FO TANK	0.95	8	FREE	10.0	40.6000	2
TANK VOID	0.95	4	FREE	0.0	----	----
Totals		12				2

INTACT DATA

Draft at AP = 2.830 ft	Kmt = 20.950 ft	LCG = 59.286A ft-FP
Draft at FP = 3.650 ft	VCG = 8.380 ft	LCB = 59.236A ft-FP
Displacement = 87 LTons	GMT = 12.570 ft	TCG = 0.000 ft-CL

DRAFT/GZ DATA

HEEL degrees	RIGHTING ARM ft	DRAFT AFT ft	DRAFT FWD ft	FLOODED WATER LTons
0.0	-0.263	3.014	3.822	11
5.0P	0.732	3.045	3.797	13
7.0P	1.051	3.048	3.740	14
10.0P	1.409	2.968	3.686	14
20.0P	2.099	2.419	3.323	16
30.0P	2.429	1.411	2.693	16
40.0P	2.516	0.036	1.623	16
50.0P	2.086	-1.723	0.041	16

Note: Drafts are measured at A.P. and F.P along ship's centerline

GZ SUMMARY (Evaluated per IMO (SOLAS'90) Rules for Passenger Ships)

	Available	Required
Static Heel Angle	1.3P deg	7.0 deg
Angle at Maximum GZ	38.0P deg	
Maximum GZ	2.542 ft	1.000 ft
Range of Positive GZ	48.7 deg	15.0 deg
Righting Area (1.3-22.0)	29.20 ft-deg	2.82 ft-deg

RTRN013B:
 102' CREW BOAT

amaged Compartments:
 H2O TANK FO TANK

	DISPLACEMENT LTons	DRAFT AFT ft	DRAFT FWD ft	TRIM ft	HEEL deg.	UPRIGHT GMT ft
INTACT	87	2.830	3.650	0.820F	0.0	12.570
DAMAGED	95	3.003	3.798	0.795F	0.9S	13.775

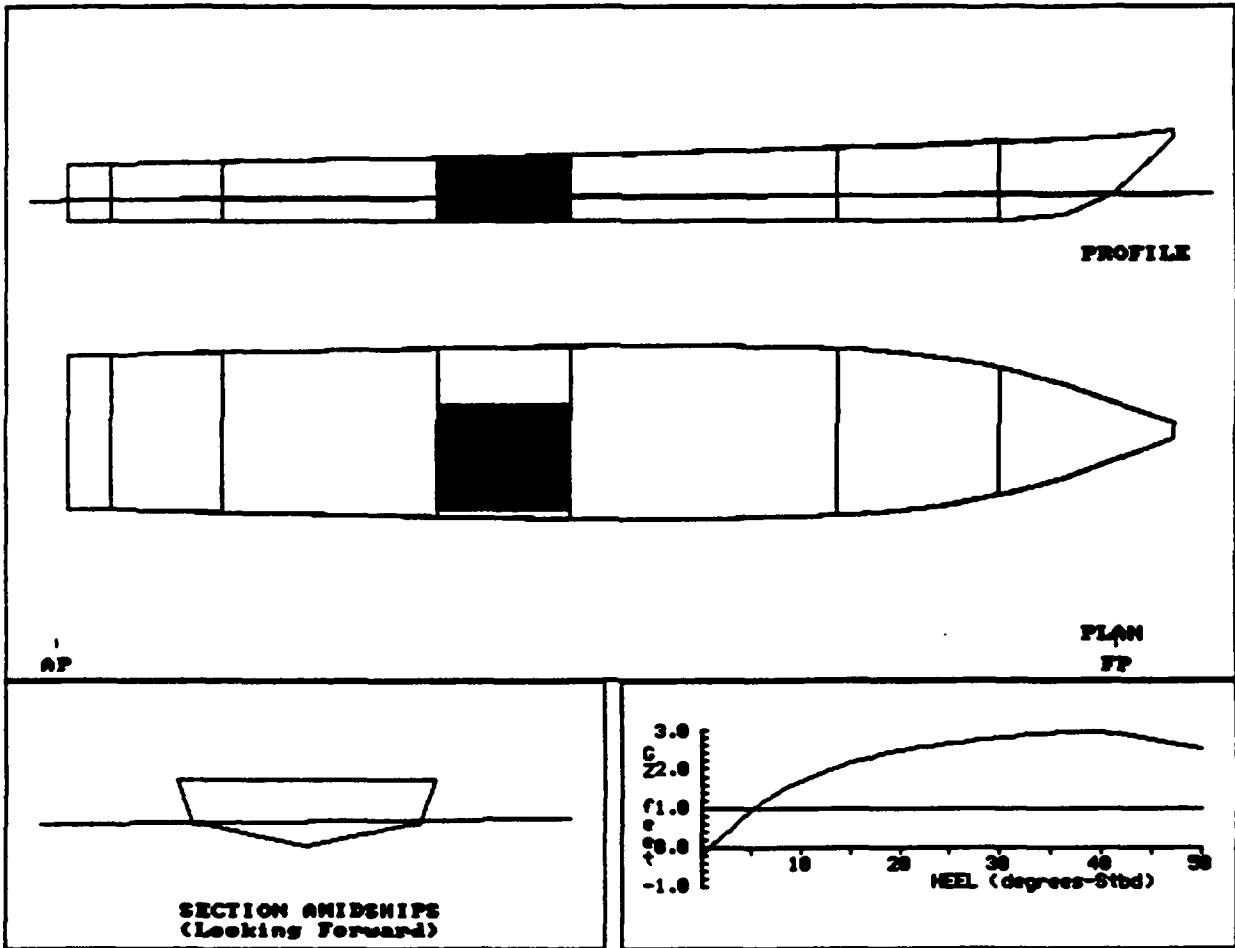

RTRN013B:
 102' CREW BOAT

COMPARTMENT FLOODING SUMMARY

At 0.9oS Heel	PERM.	FLOODED WTR LTons	% FULL (Damaged)	% FULL (Intact)	SP.VOL. ft ³ /LT	OUTFLOW LTons
H2O TANK	0.95	3	FREE	10.0	34.0000	0
FO TANK	0.95	8	FREE	10.0	40.6000	2
Totals		11				2

INTACT DATA

Draft at AP = 2.830 ft	KMT = 20.950 ft	LCG = 59.286A ft-FP
Draft at FP = 3.650 ft	VCG = 8.380 ft	LCB = 59.236A ft-FP
Displacement = 87 LTons	GMT = 12.570 ft	TCG = 0.000 ft-CL

DRAFT/GZ DATA

HEEL degrees	RIGHTING ARM ft	DRAFT AFT ft	DRAFT FWD ft	FLOODED WATER LTons
0.0	-0.220	3.003	3.807	11
5.0S	0.923	2.995	3.746	11
7.0S	1.280	2.966	3.692	11
10.0S	1.685	2.867	3.604	10
20.0S	2.458	2.209	3.180	9
30.0S	2.807	1.077	2.494	7
40.0S	2.952	-0.519	1.376	5
50.0S	2.495	-2.653	-0.309	4

Note: Drafts are measured at A.P. and F.P along ship's centerline

GZ SUMMARY (Evaluated per IMO (SOLAS'90) Rules for Passenger Ships)
 Available Required

Static Heel Angle	0.9S deg	7.0 deg
Angle at Maximum GZ	39.0S deg	
Maximum GZ	2.968 ft	1.000 ft
Range of Positive GZ	49.1 deg	15.0 deg
Righting Area (0.9-22.0)	34.92 ft-deg	2.82 ft-deg

RTRN014B:
 102' CREW BOAT

arranged Compartments:
 TANK ACCESS N2O TANK

	DISPLACEMENT LTons	DRAFT AFT ft	DRAFT FWD ft	TRIM ft	HEEL deg.	UPRIGHT GMT ft
INTACT	87	2.830	3.650	0.820F	0.0	12.570
DAMAGED	90	2.892	3.695	0.803F	1.1S	11.166

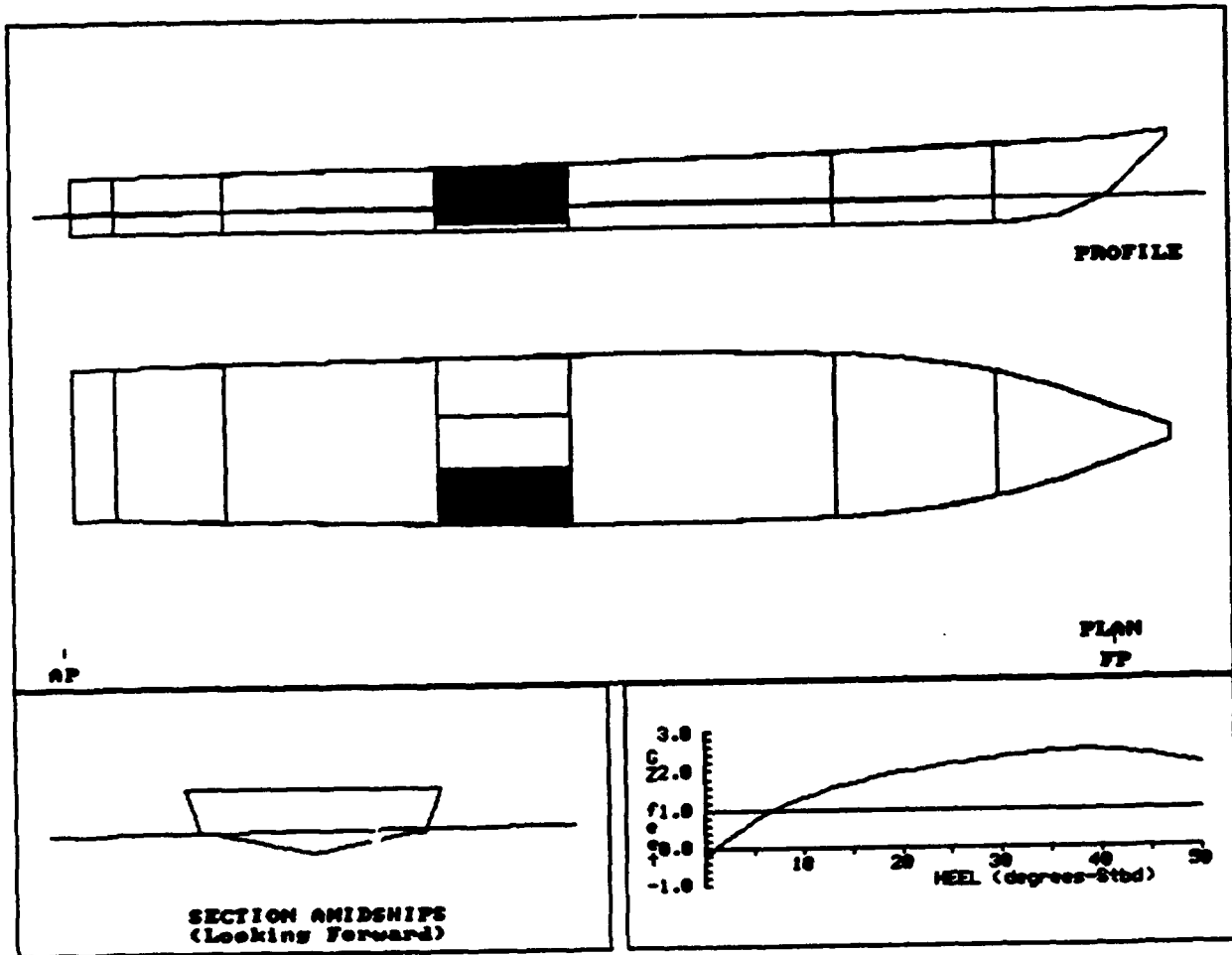

RTRN014B:
 102' CREW BOAT

COMPARTMENT FLOODING SUMMARY

At 1.1oS Heel	PERM.	FLOODED WTR LTons	% FULL (Damaged)	% FULL (Intact)	SP.VOL. ft3/LT	OUTFLOW LTons
TANK ACCESS	0.95	0	FREE	0.0	----	----
H2O TANK	0.95	3	FREE	10.0	34.0000	0
Totals		3				0

INTACT DATA

Draft at AP = 2.830 ft KMT = 20.950 ft LCG = 59.286A ft-FP
 Draft at FP = 3.650 ft VCG = 8.380 ft LCB = 59.236A ft-FP
 Displacement = 87 LTons GMT = 12.570 ft TCG = 0.000 ft-CL

DRAFT/GZ DATA

HEEL degrees	RIGHTING ARM ft	DRAFT AFT ft	DRAFT FWD ft	FLOODED WATER LTons
0.0	-0.210	2.883	3.702	3
5.0S	0.719	2.914	3.662	5
7.0S	0.994	2.892	3.627	5
10.0S	1.312	2.815	3.562	6
20.0S	1.951	2.274	3.225	9
30.0S	2.324	1.314	2.635	12
40.0S	2.491	-0.010	1.603	14
50.0S	2.125	-1.692	0.051	15

Note: Drafts are measured at A.P. and F.P along ship's centerline

GZ SUMMARY (Evaluated per IMO (SOLAS'90) Rules for Passenger Ships)

	Available	Required
Static Heel Angle	1.1S deg	7.0 deg
Angle at Maximum GZ	39.0S deg	
Maximum GZ	2.500 ft	1.000 ft
Range of Positive GZ	48.9 deg	15.0 deg
Righting Area (1.1-22.0)	27.36 ft-deg	2.82 ft-deg

**APPENDIX B
HYDROSTATICS AND
DAMAGE STABILITY
OUTPUT**

122' CREW BOAT

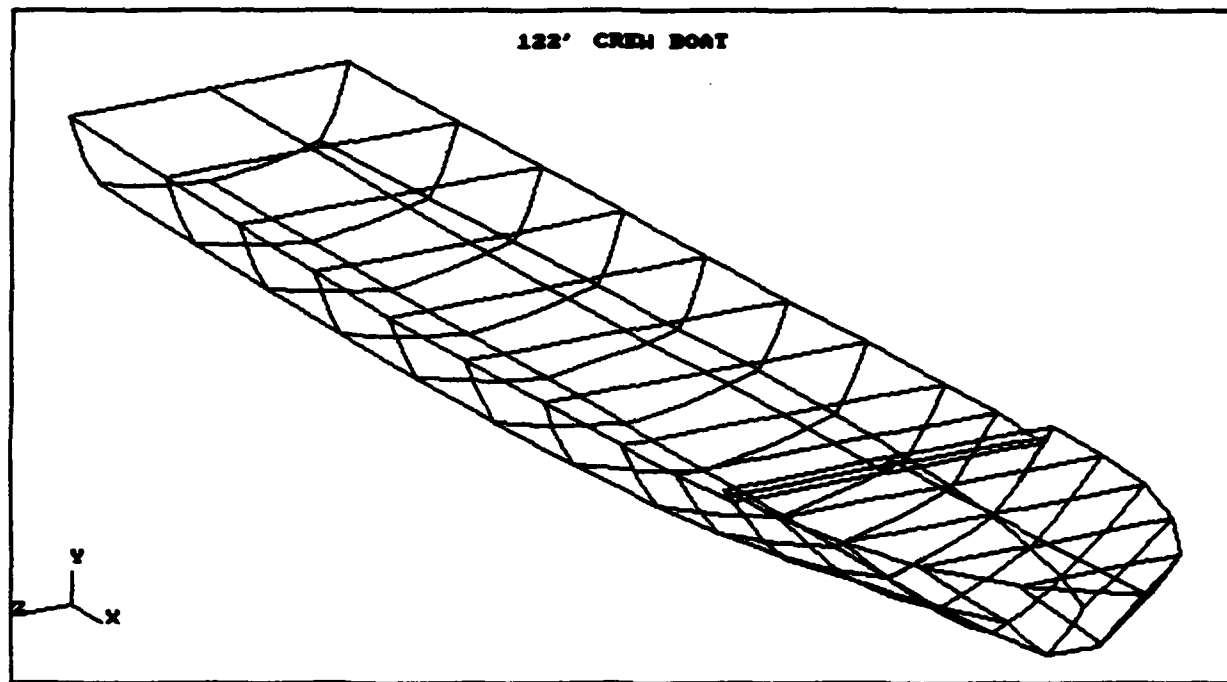

**DAMAGE STABILITY SUMMARY
 122' CREW BOAT**

CASE No.	FILE NAME	DAMAGED COMP.	LISTING	---Intact Condition---			-----Equilibrium Condition After Damage-----					
				MW.DRAFT (ft)	VCG (ft)	GMt (ft)	HEEL (deg)	MAX.GZ (ft)	RANGE (deg)	AREA (ft-deg)	DAM.GMt (ft)	SURVIVAL
1	DPRT001A	1		5.463	6.640	4.652	0.0	2.432	50.00	20.21	4.664	Yes
2	DPRT002A	2		5.463	6.640	4.652	0.0	2.347	50.00	20.79	4.780	Yes
3	DPRT003A	3		5.463	6.640	4.652	0.0	1.683	50.00	14.21	3.204	Yes
4	DPRT004A	6		5.463	6.640	4.652	0.1P	1.891	49.88	14.92	----	Yes
5	DPRT005A	10		5.463	6.640	4.652	0.0	1.749	50.00	17.41	4.070	Yes
6	DPRT006A	13		5.463	6.640	4.652	1.8S	2.201	48.23	16.83	----	Yes
7	DPRT007A	15		5.463	6.640	4.652	0.0	2.171	50.00	19.47	4.442	Yes
8	DPRT008A	15,13		5.463	6.640	4.652	2.6S	1.798	47.42	14.97	----	Yes
9	DPRT009A	3,4		5.463	6.640	4.652	0.5S	1.780	49.48	14.65	----	Yes
10	DPRT010A	6,7		5.463	6.640	4.652	0.4S	1.979	49.58	15.39	----	Yes

DAMAGE STABILITY SUMMARY
122' CREW BOAT

CA	No.	FILE NAME	DAMAGED COMP. LISTING	---Intact Condition---			-----Equilibrium Condition After Damage-----					
				MM.DRAFT (ft)	VCG (ft)	Ght (ft)	HEEL (deg)	MAX.GZ (ft)	RANGE (deg)	AREA (ft-deg)	DAM.Ght (ft)	SURVIVAL
	1	RTRN001B	1	4.698	8.200	3.723	0.0	1.676	50.00	15.33	3.709	Yes
	2	RTRN002B	2	4.698	8.200	3.723	0.0	1.731	50.00	15.90	3.724	Yes
	3	RTRN003B	3	4.698	8.200	3.723	0.0	0.973	50.00	7.77	1.724	Yes
	4	RTRN004B	6	4.698	8.200	3.723	0.1P	1.197	49.90	9.37	----	Yes
	5	RTRN005B	10	4.698	8.200	3.723	0.0	1.203	50.00	12.30	2.827	Yes
	6	RTRN006B	13	4.698	8.200	3.723	2.4S	1.513	47.55	11.76	----	Yes
	7	RTRN007B	15	4.698	8.200	3.723	0.0	1.539	50.00	14.48	3.430	Yes
	8	RTRN008B	15,13	4.698	8.200	3.723	3.8S	1.215	46.20	9.75	----	Yes
	9	RTRN009B	3,4	4.698	8.200	3.723	4.8S	1.061	45.17	6.35	----	Yes
	10	RTRN010B	6,7	4.698	8.200	3.723	4.6S	1.233	45.35	7.20	----	Yes

HYDROSTATIC TABLES
 122' CREW BOAT

MOLDED DRAFT (ft)	2.500	3.000	3.500	4.000	4.500	5.000	5.500	6.000	7.000	9.000
DISP. MLD. (LTons-SW)	57	78	102	126	151	177	204	231	287	407
DISP. TOTAL (LTons-SW)	57	79	102	126	152	178	205	232	289	409
DISP. TOTAL (LTons-FW)	56	77	100	123	148	174	200	226	282	399
LCB (ft-FP)	72.692A	72.063A	71.349A	70.687A	70.108A	69.606A	69.165A	68.769A	68.069A	66.830A
TCB (ft-CL)	0.000	0.000	0.000	0.000	0.000	0.000	0.000	0.000	0.000	0.000
KB (ft)	1.632	1.941	2.240	2.532	2.818	3.100	3.381	3.660	4.217	5.335
BMT (ft)	14.898	13.723	11.957	10.508	9.385	8.540	7.829	7.283	6.512	5.498
KM (ft)	16.530	15.664	14.198	13.039	12.203	11.640	11.210	10.943	10.729	10.833
BML (ft)	498.419	402.826	337.461	291.037	256.231	228.588	206.320	189.126	164.609	133.409
KMI (ft)	500.052	404.767	339.701	293.569	259.049	231.688	209.701	192.786	168.825	138.744
TPI (LTons)	3.4	3.8	4.0	4.1	4.3	4.4	4.5	4.6	4.8	5.2
MTlin (ft-LTons)	19	22	23	25	26	28	29	30	32	37
CMlin (LTons)	0.3	0.3	0.2	0.2	0.2	0.2	0.2	0.2	0.1	0.1
LCr (ft-FP)	71.094A	69.515A	68.358A	67.554A	66.975A	66.562A	66.132A	65.683A	64.726A	63.111A
W.P. AREA (ft2)	1,440	1,581	1,668	1,734	1,789	1,838	1,881	1,925	2,017	2,185
WETTED SUR. (ft2)	1,560	1,758	1,912	2,051	2,183	2,313	2,440	2,570	2,831	3,354
MAX. BEAM (ft)	17.606	19.066	19.396	19.725	20.054	20.383	20.712	21.042	21.700	22.577
LENGTH W.L. (ft)	104.745	105.534	106.324	107.114	107.904	108.694	109.484	110.162	110.887	112.336
Cb	0.3099	0.3568	0.3964	0.4299	0.4586	0.4836	0.5058	0.5256	0.5604	0.6182
Cm	0.4682	0.5352	0.5889	0.6314	0.6662	0.6956	0.7209	0.7430	0.7801	0.8370
Cp	0.6620	0.6666	0.6731	0.6809	0.6884	0.6953	0.7016	0.7075	0.7185	0.7386
Cup	0.5622	0.6171	0.6509	0.6767	0.6983	0.7176	0.7342	0.7514	0.7874	0.8530
Cit	0.3141	0.3997	0.4514	0.4917	0.5271	0.5619	0.5927	0.6250	0.6952	0.8324

Assumes: Sea Water at 35.0063 ft3/LT
 Fresh Water at 35.8814 ft3/LT
 Ship floating at even keel (no heel or trim)

DPRT001A: COLL1
 122' CREW BOAT

Damaged Compartments:
 FOREPEAK

	DISPLACEMENT LTons	DRAFT AFT ft	DRAFT FWD ft	TRIM ft	HEEL deg.	UPRIGHT GMT ft
INTACT	201.1	5.116	5.810	0.694F	0.00	4.652
DAMAGED	203.3	5.001	6.031	1.030F	0.00	4.664

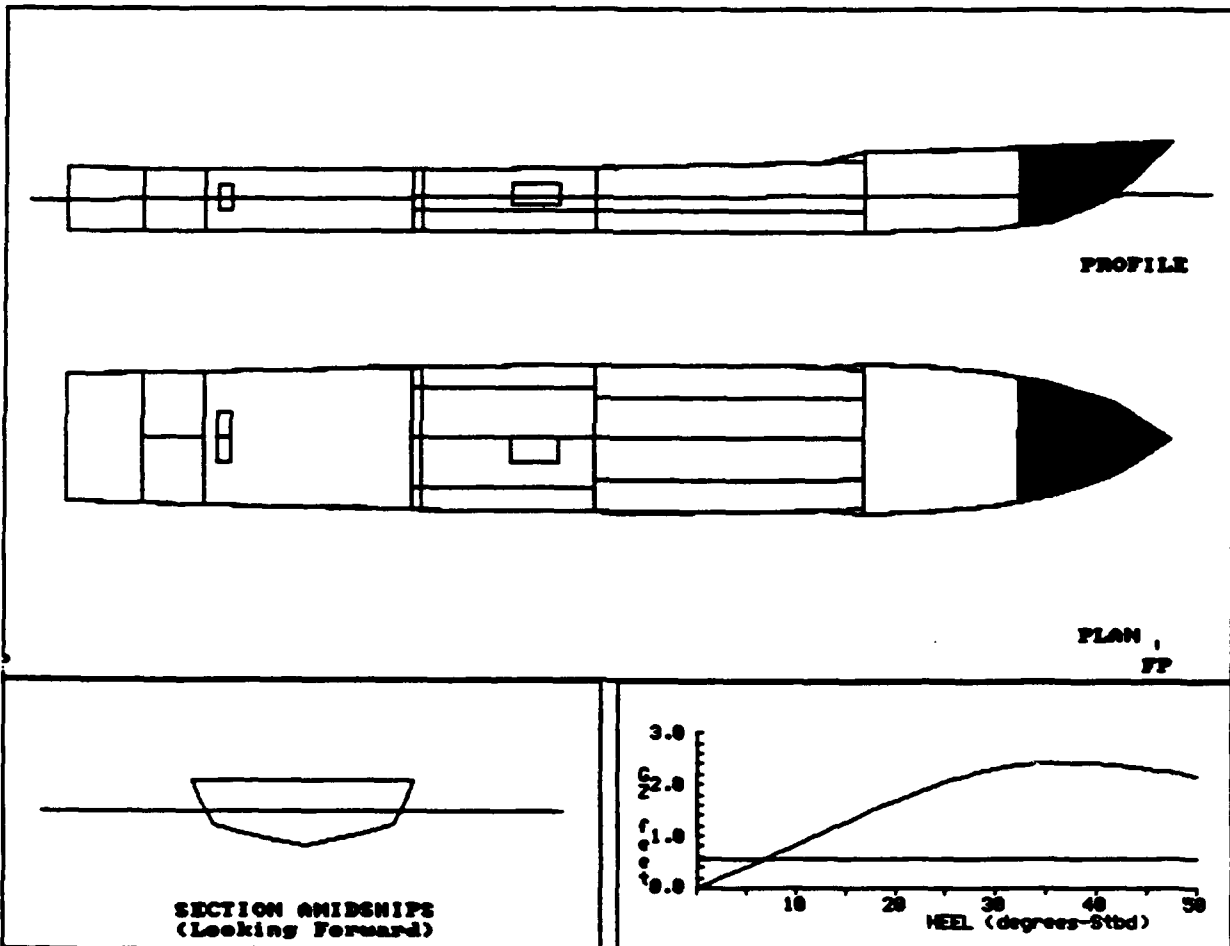

DPRT001A: COLL1
 122' CREW BOAT

COMPARTMENT FLOODING SUMMARY

At 0.0o Heel	PERM.	FLOODED WTR LTons	% FULL (Damaged)	% FULL (Intact)	SP.VOL. ft3/LT	OUTFLOW LTons
FOREPEAK	0.95	2.2	FREE	0.0	----	----
Totals		2.2				

INTACT DATA

Draft at AP = 5.116 ft	KMT = 11.292 ft	LCG = 68.029A ft-FP
Draft at FP = 5.810 ft	VCG = 6.640 ft	LCB = 68.010A ft-FP
Displacement = 201.1 LTons	GMT = 4.652 ft	TCG = 0.000 ft-CL

DRAFT/GZ DATA

HEEL degrees	RIGHTING ARM ft	DRAFT AFT ft	DRAFT FWD ft	FLOODED WATER LTons
0.00	0.000	5.001	6.031	2.2
5.00S	0.408	5.000	6.003	2.2
7.00S	0.574	4.993	5.984	2.1
10.00S	0.826	4.985	5.933	2.1
20.00S	1.683	4.868	5.654	1.9
30.00S	2.308	4.571	5.071	1.6
40.00S	2.410	4.410	4.152	1.2
50.00S	2.163	4.335	2.892	1.2

Note: Drafts are measured at A.P. and F.P along ship's centerline

GZ SUMMARY (Evaluated per IMO (SOLAS'90) Rules for Passenger Ships)
 Available Required

Static Heel Angle	0.00 deg	7.00 deg
Angle at Maximum GZ	38.00S deg	
Maximum GZ	2.432 ft	0.560 ft
Range of Positive GZ	50.00 deg	15.00 deg
Gmt (upright damaged)	4.664 ft	
Righting Area (0.00-%.00)	20.211 ft-deg	2.820 ft-deg

DPRT002A: COLL2
 122' CREW BOAT

Damaged Compartments:
 GALLEY

	DISPLACEMENT LTons	DRAFT AFT ft	DRAFT FWD ft	TRIM ft	HEEL deg.	UPRIGHT GMT ft
INTACT	201.1	5.116	5.810	0.694F	0.00	4.652
DAMAGED	226.5	4.223	7.802	3.579F	0.00	4.780

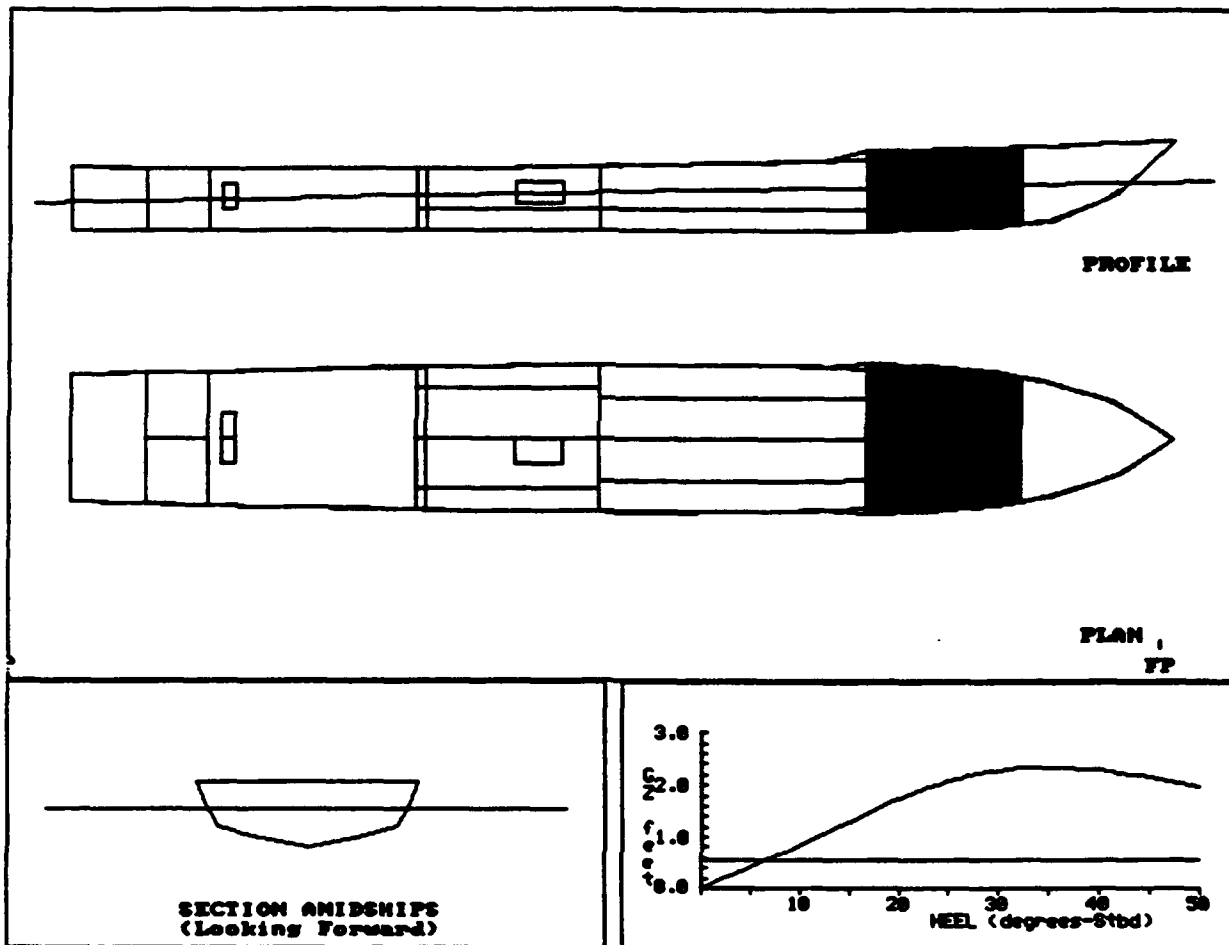

DPRT002A: COLL2
 122' CREW BOAT

COMPARTMENT FLOODING SUMMARY

At 0.0o Heel	PERM.	FLOODED WTR LTons	% FULL (Damaged)	% FULL (Intact)	SP.VOL. ft3/LT	OUTFLOW LTons
GALLEY	0.95	25.4	FREE	0.0	----	----
Totals		25.4				

INTACT DATA

Draft at AP = 5.116 ft	KMt = 11.292 ft	LCG = 68.029A ft-FP
Draft at FP = 5.810 ft	VCG = 6.640 ft	LCB = 68.010A ft-FP
Displacement = 201.1 LTons	Gmt = 4.652 ft	TCG = 0.000 ft-CL

DRAFT/GZ DATA

HEEL degrees	RIGHTING ARM ft	DRAFT AFT ft	DRAFT FWD ft	FLOODED WATER LTons
0.00	0.000	4.223	7.802	25.4
5.00S	0.418	4.214	7.784	25.4
7.00S	0.586	4.206	7.768	25.4
10.00S	0.842	4.190	7.729	25.5
20.00S	1.739	4.053	7.511	25.8
30.00S	2.286	3.649	7.258	27.5
40.00S	2.288	3.222	6.994	29.8
50.00S	1.976	2.779	6.645	30.9

Note: Drafts are measured at A.P. and F.P along ship's centerline

GZ SUMMARY (Evaluated per IMO (SOLAS'90) Rules for Passenger Ships)

	Available	Required
Static Heel Angle	0.00 deg	7.00 deg
Angle at Maximum GZ	36.00S deg	
Maximum GZ	2.347 ft	0.560 ft
Range of Positive GZ	50.00 deg	15.00 deg
Gmt (upright damaged)	4.780 ft	
Righting Area (0.00-%.00)	20.792 ft-deg	2.820 ft-deg

DFRT003A: COLL3
 122' CREW BOAT

amaged Compartments:
 PASS CABIN

	DISPLACEMENT LTons	DRAFT AFT ft	DRAFT FWD ft	TRIM ft	HEEL deg.	UPRIGHT Gmt ft
INTACT	201.1	5.116	5.810	0.694F	0.00	4.652
DAMAGED	255.4	4.743	8.290	3.547F	0.00	3.204

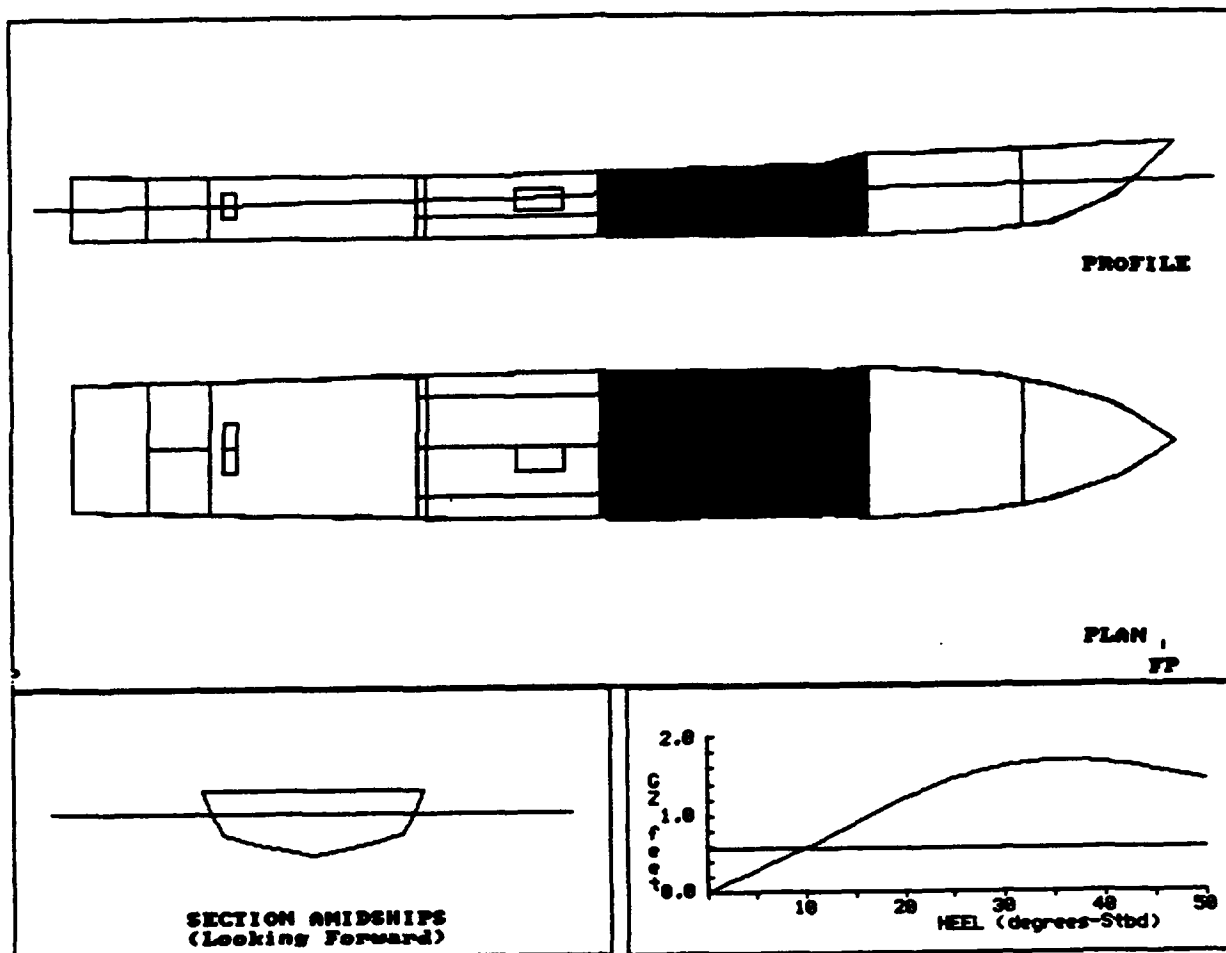

DPRT003A: COLL3
 122' CREW BOAT

COMPARTMENT FLOODING SUMMARY

At 0.0o Heel	PERM.	FLOODED WTR LTons	% FULL (Damaged)	% FULL (Intact)	SP.VOL. ft3/LT	OUTFLOW LTons
PASS CABIN	0.95	54.3	FREE	0.0	----	----
Totals		54.3				

INTACT DATA

Draft at AP = 5.116 ft	KMt = 11.292 ft	LCG = 68.029A ft-FP
Draft at FP = 5.810 ft	VCG = 6.640 ft	LCB = 68.010A ft-FP
Displacement = 201.1 LTons	Gmt = 4.652 ft	TCG = 0.000 ft-CL

DRAFT/GZ DATA

HEEL degrees	RIGHTING ARM ft	DRAFT AFT ft	DRAFT FWD ft	FLOODED WATER LTons
0.00	0.000	4.743	8.290	54.3
5.00S	0.281	4.737	8.270	54.3
7.00S	0.395	4.731	8.252	54.3
10.00S	0.568	4.717	8.210	54.3
20.00S	1.202	4.633	7.941	54.1
30.00S	1.612	4.471	7.569	52.7
40.00S	1.659	4.485	7.134	52.9
50.00S	1.429	4.604	6.702	53.6

Note: Drafts are measured at A.P. and F.P along ship's centerline

GZ SUMMARY (Evaluated per IMO (SOLAS'90) Rules for Passenger Ships)

	Available	Required
Static Heel Angle	0.00 deg	7.00 deg
Angle at Maximum GZ	37.00S deg	
Maximum GZ	1.683 ft	0.560 ft
Range of Positive GZ	50.00 deg	15.00 deg
Gmt (upright damaged)	3.204 ft	
Righting Area (0.00-7.00)	14.209 ft-deg	2.820 ft-deg

DPRT004A: COLL4
 122' CREW BOAT

Managed Compartments:
 GENERATOR RM

	DISPLACEMENT LTons	DRAFT AFT ft	DRAFT FWD ft	TRIM ft	HEEL deg.	UPRIGHT GMT ft
INTACT	201.1	5.116	5.810	0.694F	0.00	4.652
DAMAGED	225.4	5.666	6.130	0.464F	0.12P	3.381

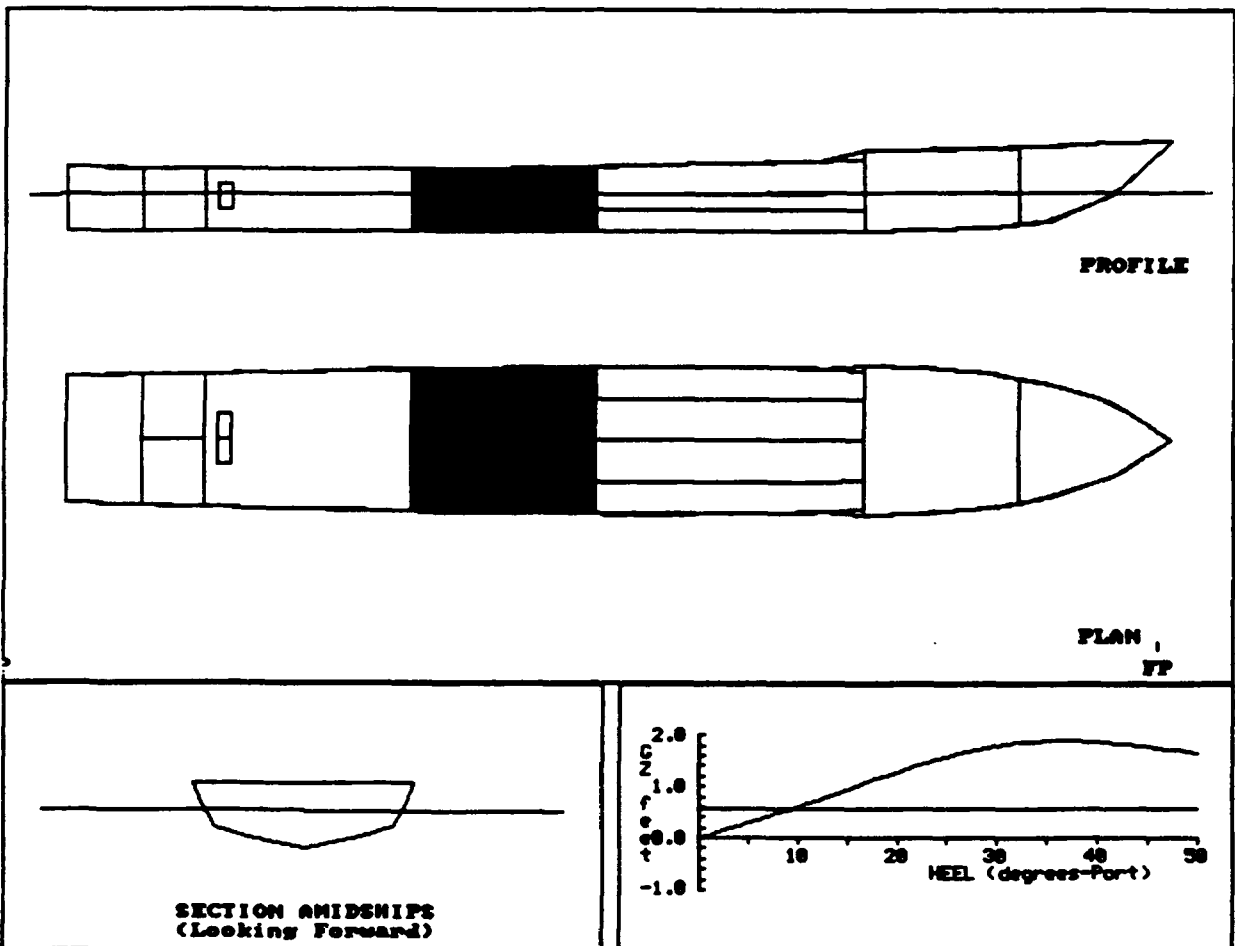

DPRT004A: COLL4
 122' CREW BOAT

COMPARTMENT FLOODING SUMMARY

At 0.10P Heel	PERM.	FLOODED WTR LTons	% FULL (Damaged)	% FULL (Intact)	SP.VOL. ft3/LT	OUTFLOW LTons
GENERATOR RM	0.85	24.3	FREE	0.0	----	----
Totals		24.3				

INTACT DATA

Draft at AP = 5.116 ft	KMt = 11.292 ft	LCG = 68.029A ft-FP
Draft at FP = 5.810 ft	VCG = 6.640 ft	LCB = 68.010A ft-FP
Displacement = 201.1 LTons	GMt = 4.652 ft	TCG = 0.000 ft-CL

DRAFT/GZ DATA

HEEL degrees	RIGHTING ARM ft	DRAFT AFT ft	DRAFT FWD ft	FLOODED WATER LTons
0.00	-0.007	5.666	6.131	24.3
5.00P	0.290	5.666	6.107	24.4
7.00P	0.412	5.661	6.088	24.4
10.00P	0.597	5.653	6.042	24.5
20.00P	1.272	5.554	5.798	24.9
30.00P	1.799	5.534	5.260	26.9
40.00P	1.867	5.808	4.396	28.3
50.00P	1.650	6.368	3.157	29.4

Note: Drafts are measured at A.P. and F.P along ship's centerline

GZ SUMMARY (Evaluated per IMO (SOLAS'90) Rules for Passenger Ships)

	Available	Required
Static Heel Angle	0.12P deg	7.00 deg
Angle at Maximum GZ	37.00P deg	
Maximum GZ	1.891 ft	0.560 ft
Range of Positive GZ	49.88 deg	15.00 deg
Righting Area (0.12-%.00)	14.920 ft-deg	2.820 ft-deg

DPRT005A: COLL5
122' CREW BOAT

Managed Compartments:
 ENGINE ROOM

	DISPLACEMENT LTons	DRAFT AFT ft	DRAFT FWD ft	TRIM ft	HEEL deg.	UPRIGHT GMT ft
INTACT	201.1	5.116	5.810	0.694F	0.00	4.652
DAMAGED	263.3	8.104	4.740	3.364A	0.00	4.070

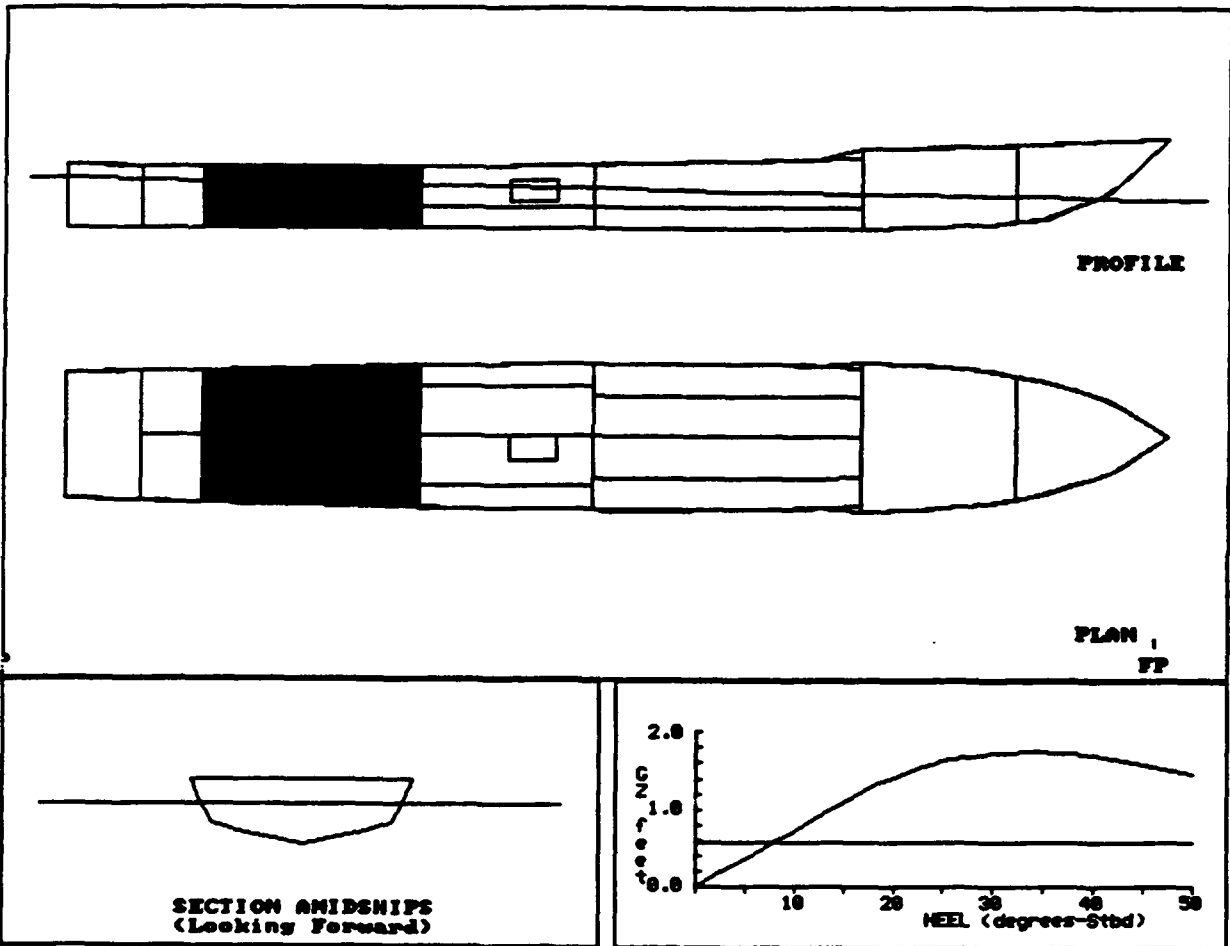

DPRT005A: COLL5
 122' CREW BOAT

COMPARTMENT FLOODING SUMMARY

At 0.0o Heel	PERM.	FLOODED WTR LTons	% FULL (Damaged)	% FULL (Intact)	SP.VOL. ft ³ /LT	OUTFLOW LTons
ENGINE ROOM	0.85	62.2	FREE	0.0	----	----
Totals		62.2				

INTACT DATA

Draft at AP = 5.116 ft KMT = 11.292 ft LCG = 68.029A ft-FP
 Draft at FP = 5.810 ft VCG = 6.640 ft LCB = 68.010A ft-FP
 Displacement = 201.1 LTons GMT = 4.652 ft TCG = 0.000 ft-CL

DRAFT/GZ DATA

HEEL degrees	RIGHTING ARM ft	DRAFT AFT ft	DRAFT FWD ft	FLOODED WATER LTons
0.00	0.000	8.104	4.740	62.2
5.00S	0.357	8.107	4.712	62.2
7.00S	0.502	8.102	4.694	62.2
10.00S	0.724	8.079	4.664	62.2
20.00S	1.418	8.195	4.294	62.1
30.00S	1.727	8.896	3.428	61.3
40.00S	1.699	10.201	2.070	61.0
50.00S	1.473	12.209	0.127	61.0

Note: Drafts are measured at A.P. and F.P along ship's centerline

GZ SUMMARY (Evaluated per IMO (SOLAS'90) Rules for Passenger Ships)
 Available Required

Static Heel Angle	0.00 deg	7.00 deg
Angle at Maximum GZ	35.00S deg	
Maximum GZ	1.749 ft	0.560 ft
Range of Positive GZ	50.00 deg	15.00 deg
Gmt (upright damaged)	4.070 ft	
Righting Area (0.00-7.00)	17.407 ft-deg	2.820 ft-deg

DPRT006A: COLL6
122' CREW BOAT

Damaged Compartments:
 BALLAST STD

	DISPLACEMENT LTons	DRAFT AFT ft	DRAFT FWD ft	TRIM ft	HEEL deg.	UPRIGHT GMT ft
INTACT	201.1	5.116	5.810	0.694F	0.00	4.652
DAMAGED	208.3	5.610	5.513	0.097A	1.77S	4.508

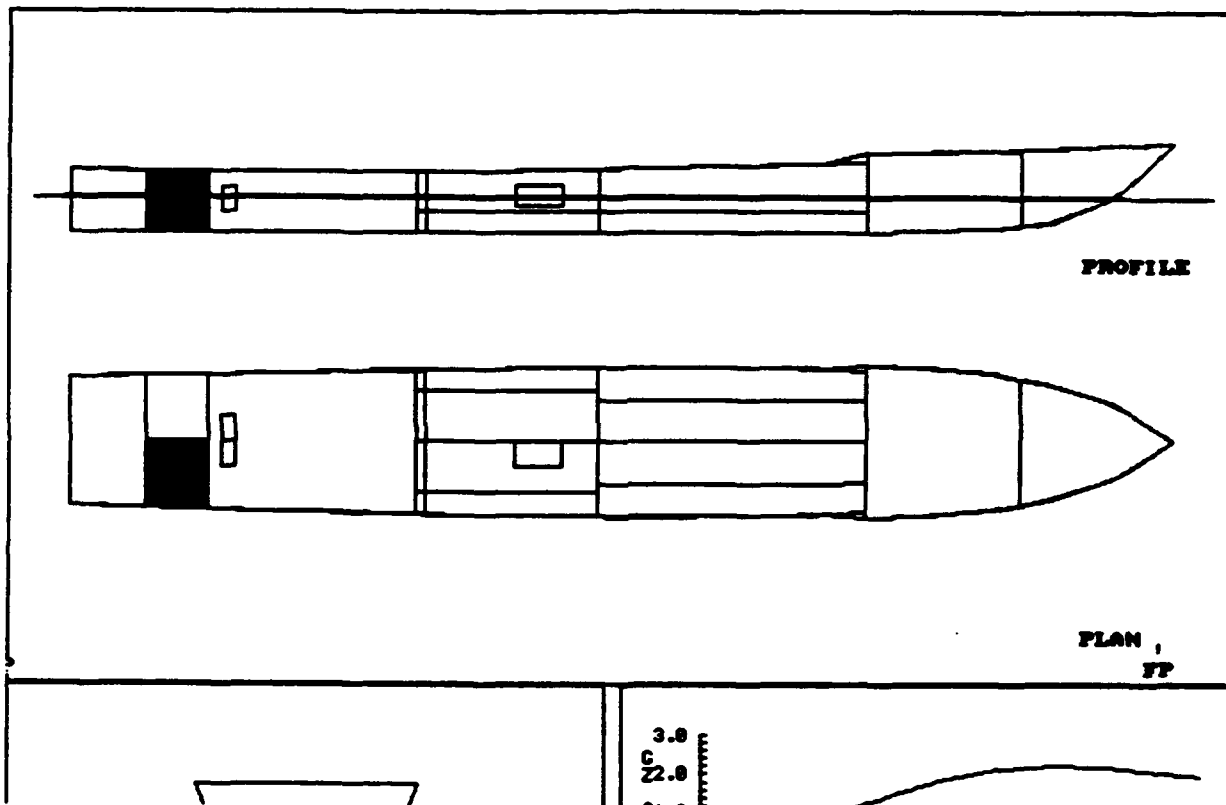

DPRT007A: COLL7
 122' CREW BOAT

Damaged Compartments:
 LAZARETTE

	DISPLACEMENT LTons	DRAFT AFT ft	DRAFT FWD ft	TRIM ft	HEEL deg.	UPRIGHT GMT ft
INTACT	201.1	5.116	5.810	0.694F	0.00	4.652
DAMAGED	221.2	6.686	4.759	1.926A	0.00	4.442

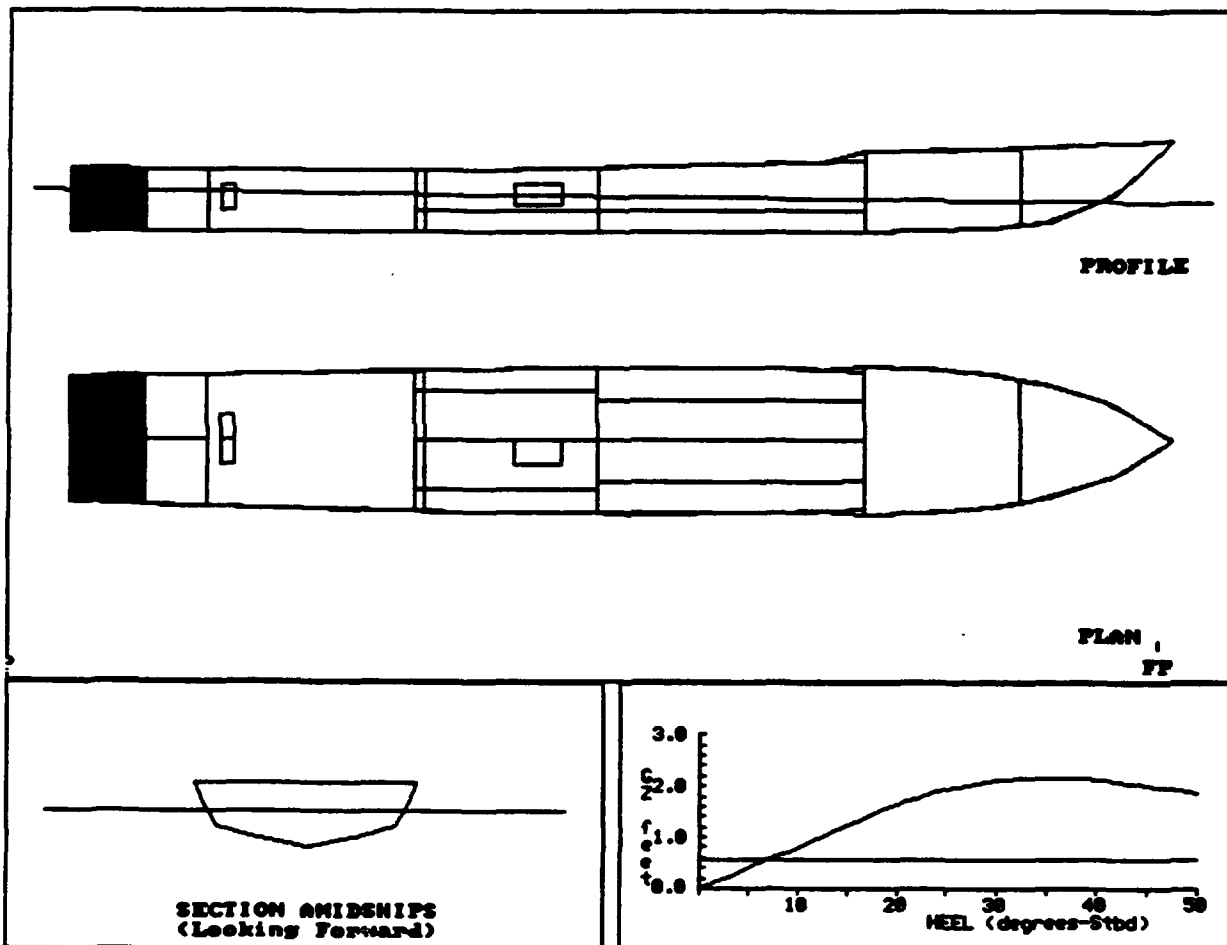

DPRT007A: COLL7
 122' CREW BOAT

COMPARTMENT FLOODING SUMMARY

At 0.0o Heel	PERM.	FLOODED WTR LTons	% FULL (Damaged)	% FULL (Intact)	SP.VOL. ft3/LT	OUTFLOW LTons
LAZARETTE	0.95	20.1	FREE	0.0	----	----
Totals		20.1				

INTACT DATA

Draft at AP = 5.116 ft	KMT = 11.292 ft	LCG = 68.029A ft-FP
Draft at FP = 5.810 ft	VCG = 6.640 ft	LCB = 68.010A ft-FP
Displacement = 201.1 LTons	GMT = 4.652 ft	TCG = 0.000 ft-CL

DRAFT/GZ DATA

HEEL degrees	RIGHTING ARM ft	DRAFT AFT ft	DRAFT FWD ft	FLOODED WATER LTons
0.00	0.000	6.686	4.759	20.1
5.00S	0.390	6.689	4.729	20.2
7.00S	0.549	6.683	4.711	20.2
10.00S	0.792	6.660	4.681	20.1
20.00S	1.624	6.585	4.375	20.2
30.00S	2.114	6.766	3.591	20.4
40.00S	2.125	7.361	2.328	20.7
50.00S	1.874	8.416	0.457	21.1

Note: Drafts are measured at A.P. and F.P along ship's centerline

GZ SUMMARY (Evaluated per IMO (SOLAS'90) Rules for Passenger Ships)

	Available	Required
Static Heel Angle	0.00 deg	7.00 deg
Angle at Maximum GZ	36.00S deg	
Maximum GZ	2.171 ft	0.560 ft
Range of Positive GZ	50.00 deg	15.00 deg
Gmt (upright damaged)	4.442 ft	
Righting Area (0.00-%.00)	19.470 ft-deg	2.820 ft-deg

DPRT008A: COLLS
 122' CREW BOAT

Damaged Compartments:
 LAZARETTE BALLAST STBD

	DISPLACEMENT LTons	DRAFT AFT ft	DRAFT FWD ft	TRIM ft	HEEL deg.	UPRIGHT GMT ft
INTACT	201.1	5.116	5.810	0.694F	0.00	4.652
DAMAGED	234.1	7.586	4.184	3.402A	2.58S	4.400

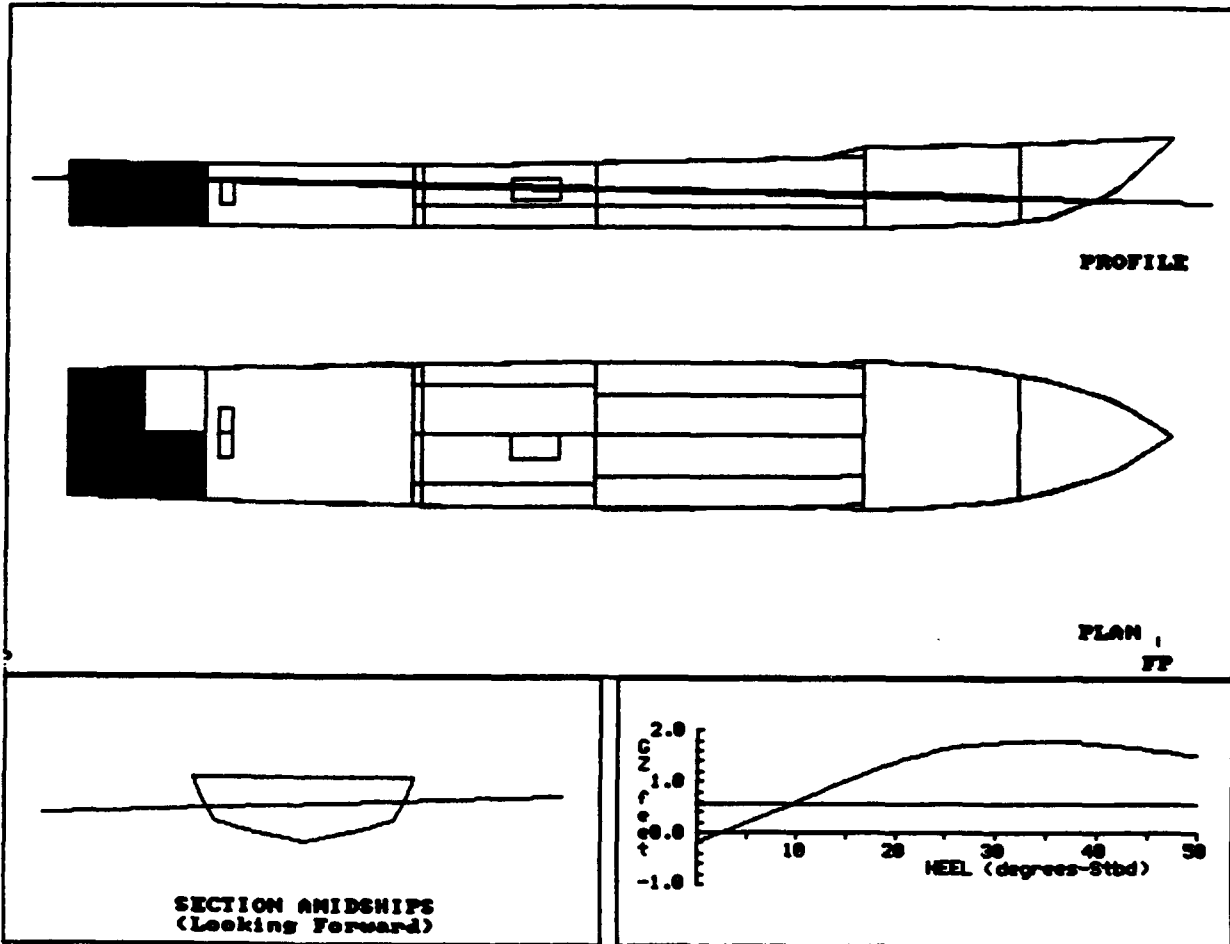

DFRT008A: COLLS
 122' CREW BOAT

COMPARTMENT FLOODING SUMMARY

At 2.6oS Heel	PERM.	FLOODED WTR LTons	% FULL (Damaged)	% FULL (Intact)	SP.VOL. ft ³ /LT	OUTFLOW LTons
LAZARETTE	0.95	23.2	FREE	0.0	----	----
BALLAST STBD	0.95	9.8	FREE	0.0	----	----
Totals		33.0				

INTACT DATA

Draft at AP = 5.116 ft	Kmt = 11.292 ft	LCG = 68.029A ft-FP
Draft at FP = 5.810 ft	VCG = 6.640 ft	LCB = 68.010A ft-FP
Displacement = 201.1 LTons	GMt = 4.652 ft	TCG = 0.000 ft-CL

DRAFT/GZ DATA

HEEL degrees	RIGHTING ARM ft	DRAFT AFT ft	DRAFT FWD ft	FLOODED WATER LTons
0.00	-0.198	7.557	4.210	32.5
5.00S	0.187	7.619	4.148	33.6
7.00S	0.343	7.654	4.098	34.1
10.00S	0.584	7.683	4.031	34.7
20.00S	1.376	7.865	3.565	36.8
30.00S	1.766	8.589	2.518	38.3
40.00S	1.746	9.878	0.941	39.3
50.00S	1.520	11.822	-1.334	39.9

Note: Drafts are measured at A.P. and F.P along ship's centerline

GZ SUMMARY (Evaluated per IMO (SOLAS'90) Rules for Passenger Ships)
 Available Required

Static Heel Angle	2.58S deg	7.00 deg
Angle at Maximum GZ	35.00S deg	
Maximum GZ	1.798 ft	0.560 ft
Range of Positive GZ	47.42 deg	15.00 deg
Righting Area (2.58-3.00)	14.965 ft-deg	2.820 ft-deg

DPRT009A: GROUND1
 122' CREW BOAT

Damaged Compartments:
 PASS CABIN FO TANK S

	DISPLACEMENT LTons	DRAFT AFT ft	DRAFT FWD ft	TRIM ft	HEEL deg.	UPRIGHT GMT ft
INTACT	201.1	5.116	5.810	0.694F	0.00	4.652
DAMAGED	258.8	4.726	8.429	3.703F	0.52S	3.454

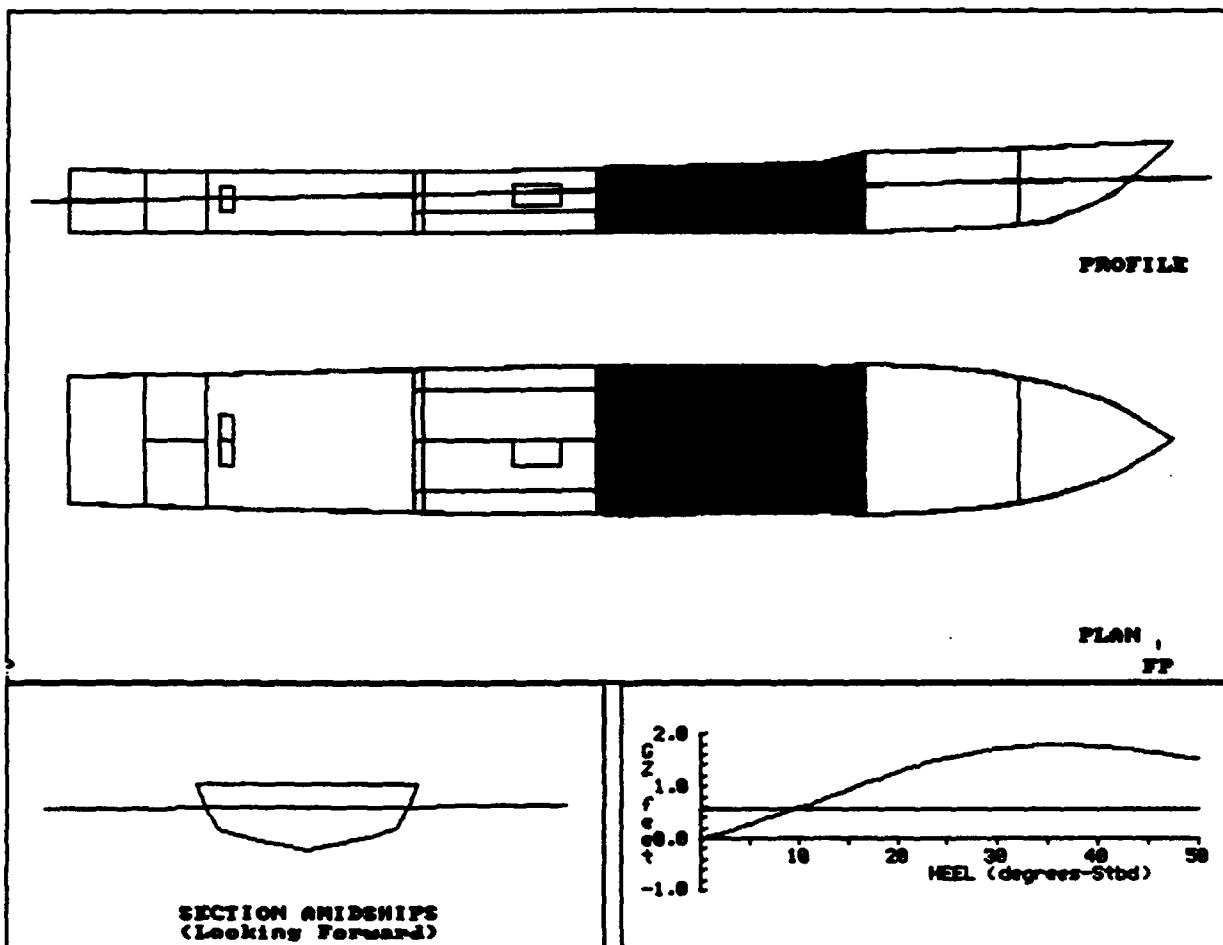

DPRT009A: GROUND1
 122' CREW BOAT

COMPARTMENT FLOODING SUMMARY

At 0.5oS Heel	PERM.	FLOODED WTR LTons	% FULL (Damaged)	% FULL (Intact)	SP.VOL. ft ³ /LT	OUTFLOW LTons
PASS CABIN	0.95	55.6	FREE	0.0	----	----
FO TANK S	0.95	11.7	FREE	95.0	40.6000	9.6
Totals		67.3				9.6

INTACT DATA

Draft at AP = 5.116 ft	KMT = 11.292 ft	LCG = 68.029A ft-FP
Draft at FP = 5.810 ft	VCG = 6.640 ft	LCB = 68.010A ft-FP
Displacement = 201.1 LTons	GMT = 4.652 ft	TCG = 0.000 ft-CL

DRAFT/GZ DATA

HEEL degrees	RIGHTING ARM ft	DRAFT AFT ft	DRAFT FWD ft	FLOODED WATER LTons
0.00	-0.031	4.727	8.431	67.3
5.00S	0.272	4.721	8.411	67.3
7.00S	0.395	4.714	8.393	67.3
10.00S	0.582	4.701	8.351	67.3
20.00S	1.265	4.616	8.084	67.1
30.00S	1.704	4.468	7.712	65.3
40.00S	1.755	4.504	7.279	65.3
50.00S	1.519	4.613	6.912	66.0

Note: Drafts are measured at A.P. and F.P along ship's centerline

GZ SUMMARY (Evaluated per IMO (SOLAS'90) Rules for Passenger Ships)
 Available Required

Static Heel Angle	0.52S deg	7.00 deg
Angle at Maximum GZ	37.00S deg	
Maximum GZ	1.780 ft	0.560 ft
Range of Positive GZ	49.48 deg	15.00 deg
Righting Area (0.52-%.00)	14.649 ft-deg	2.820 ft-deg

DPRT010A: GROUND2
 122' CREW BOAT

Damaged Compartments:
 GENERATOR RM FO TANK 2 ST

	DISPLACEMENT LTons	DRAFT AFT ft	DRAFT FWD ft	TRIM ft	HEEL deg.	UPRIGHT Gmt ft
INTACT	201.1	5.116	5.810	0.694F	0.00	4.652
DAMAGED	227.6	5.718	6.158	0.440F	0.42S	3.593

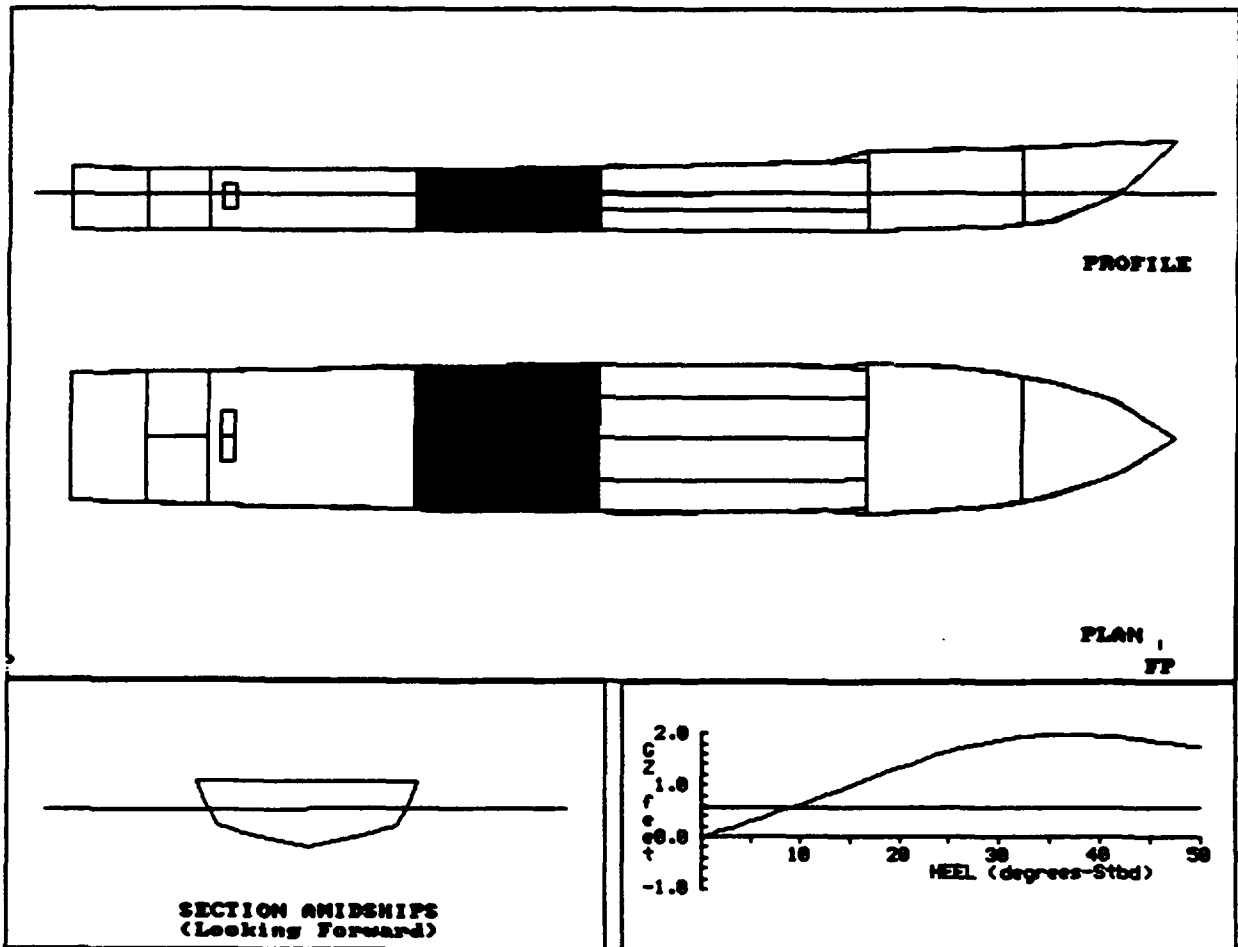

DPRT010A: GROUND2
 122' CREW BOAT

COMPARTMENT FLOODING SUMMARY

At 0.4oS Heel	PERM.	FLOODED WTR LTons	% FULL (Damaged)	% FULL (Intact)	SP.VOL. ft ³ /LT	OUTFLOW LTons
GENERATOR RM	0.85	24.6	FREE	0.0	----	----
FO TNK2 ST	0.95	10.3	FREE	95.0	40.6000	8.5
Totals		35.0				8.5

INTACT DATA

Draft at AP = 5.116 ft	KMT = 11.292 ft	LCG = 68.029A ft-FP
Draft at FP = 5.810 ft	VCG = 6.640 ft	LCB = 68.010A ft-FP
Displacement = 201.1 LTons	GMT = 4.652 ft	TCG = 0.000 ft-CL

DRAFT/GZ DATA

HEEL degrees	RIGHTING ARM ft	DRAFT AFT ft	DRAFT FWD ft	FLOODED WATER LTons
0.00	-0.026	5.718	6.160	35.0
5.00S	0.289	5.715	6.131	34.9
7.00S	0.418	5.707	6.112	34.9
10.00S	0.615	5.698	6.063	34.8
20.00S	1.327	5.590	5.813	34.8
30.00S	1.880	5.575	5.269	36.5
40.00S	1.956	5.860	4.401	37.7
50.00S	1.735	6.433	3.160	38.7

Note: Drafts are measured at A.P. and F.P along ship's centerline

GZ SUMMARY (Evaluated per IMO (SOLAS'90) Rules for Passenger Ships)
 Available Required

Static Heel Angle	0.42S deg	7.00 deg
Angle at Maximum GZ	37.00S deg	
Maximum GZ	1.979 ft	0.560 ft
Range of Positive GZ	49.58 deg	15.00 deg
Righting Area (0.42-%.00)	15.394 ft-deg	2.820 ft-deg

RTRN001B: COLL1
 122' CREW BOAT

amaged Compartments:
 FOREPEAK

	DISPLACEMENT LTons	DRAFT AFT ft	DRAFT FWD ft	TRIM ft	HEEL deg.	UPRIGHT GMT ft
INTACT	162.9	4.875	4.520	0.355A	0.00	3.723
DAMAGED	163.9	4.802	4.654	0.148A	0.00	3.709

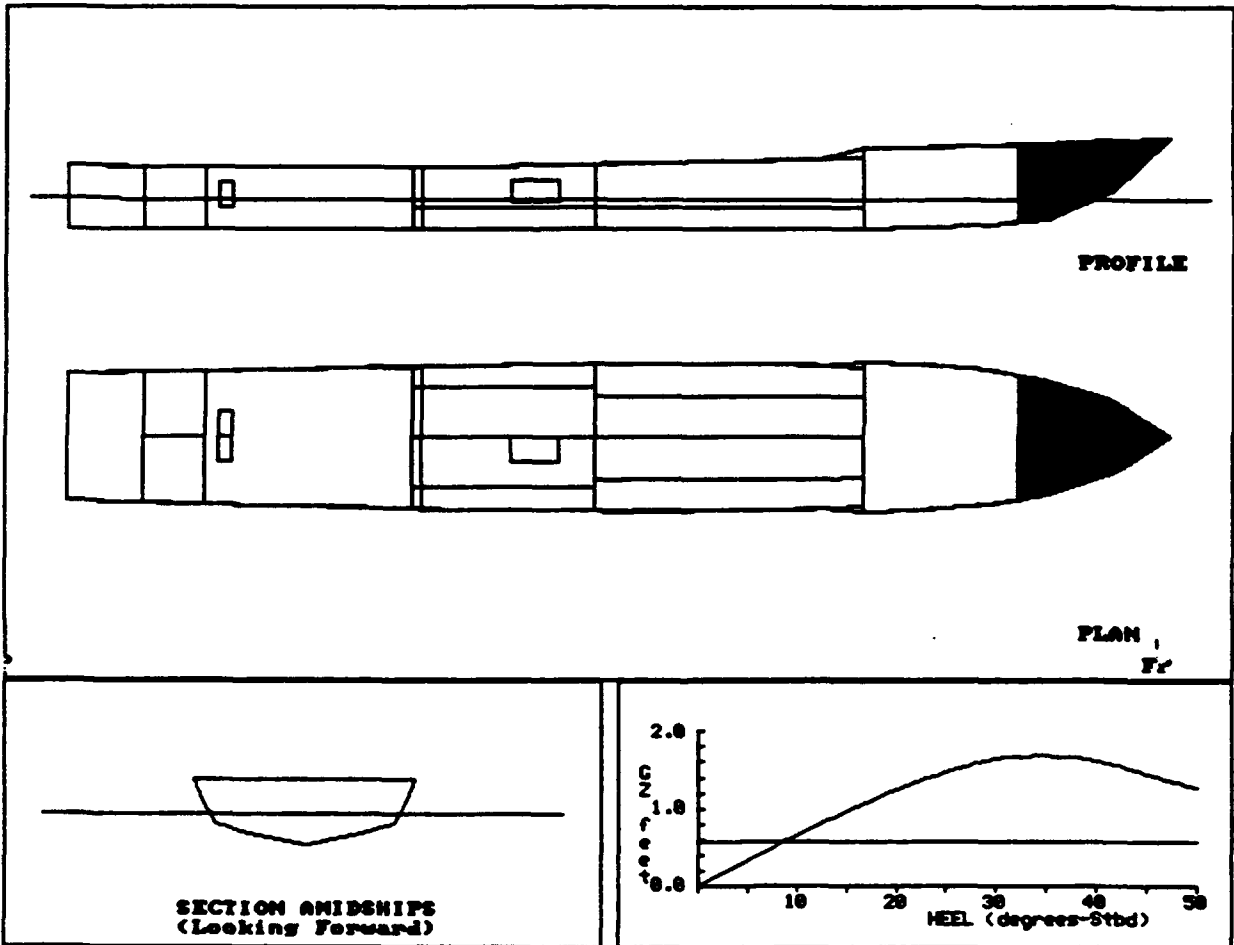

RTRN001B: COLL1
 122' CREW BOAT

COMPARTMENT FLOODING SUMMARY

At 0.0o Heel	PERM.	FLOODED WTR LTons	% FULL (Damaged)	% FULL (Intact)	SP.VOL. ft3/LT	OUTFLOW LTons
FOREPEAK	0.95	1.1	FREE	0.0	----	----
Totals		1.1				

INTACT DATA

Draft at AP = 4.875 ft	KMt = 11.923 ft	LCG = 70.578A ft-FP
Draft at FP = 4.520 ft	VCG = 8.200 ft	LCB = 70.593A ft-FP
Displacement = 162.9 LTons	GMT = 3.723 ft	TCG = 0.000 ft-CL

DRAFT/GZ DATA

HEEL degrees	RIGHTING ARM ft	DRAFT AFT ft	DRAFT FWD ft	FLOODED WATER LTons
0.00	0.000	4.802	4.654	1.1
5.00S	0.324	4.815	4.607	1.0
7.00S	0.455	4.807	4.587	1.0
10.00S	0.653	4.785	4.548	1.0
20.00S	1.230	4.663	4.167	0.8
30.00S	1.630	4.234	3.491	0.5
40.00S	1.608	3.789	2.350	0.2
50.00S	1.253	3.371	0.633	0.0

Note: Drafts are measured at A.P. and F.P along ship's centerline

GZ SUMMARY (Evaluated per IMO (SOLAS'90) Rules for Passenger Ships)
 Available Required

Static Heel Angle	0.00 deg	7.00 deg
Angle at Maximum GZ	35.00S deg	
Maximum GZ	1.676 ft	0.560 ft
Range of Positive GZ	50.00 deg	15.00 deg
Gmt (upright damaged)	3.709 ft	
Righting Area (0.00-%.00)	15.332 ft-deg	2.820 ft-deg

RTRN002B: COLL2
 122' CREW BOAT

Damaged Compartments:
 GALLEY

	DISPLACEMENT LTons	DRAFT AFT ft	DRAFT FWD ft	TRIM ft	HEEL deg.	UPRIGHT GMT ft
INTACT	162.9	4.875	4.520	0.355A	0.00	3.723
DAMAGED	179.4	4.218	5.984	1.766F	0.00	3.724

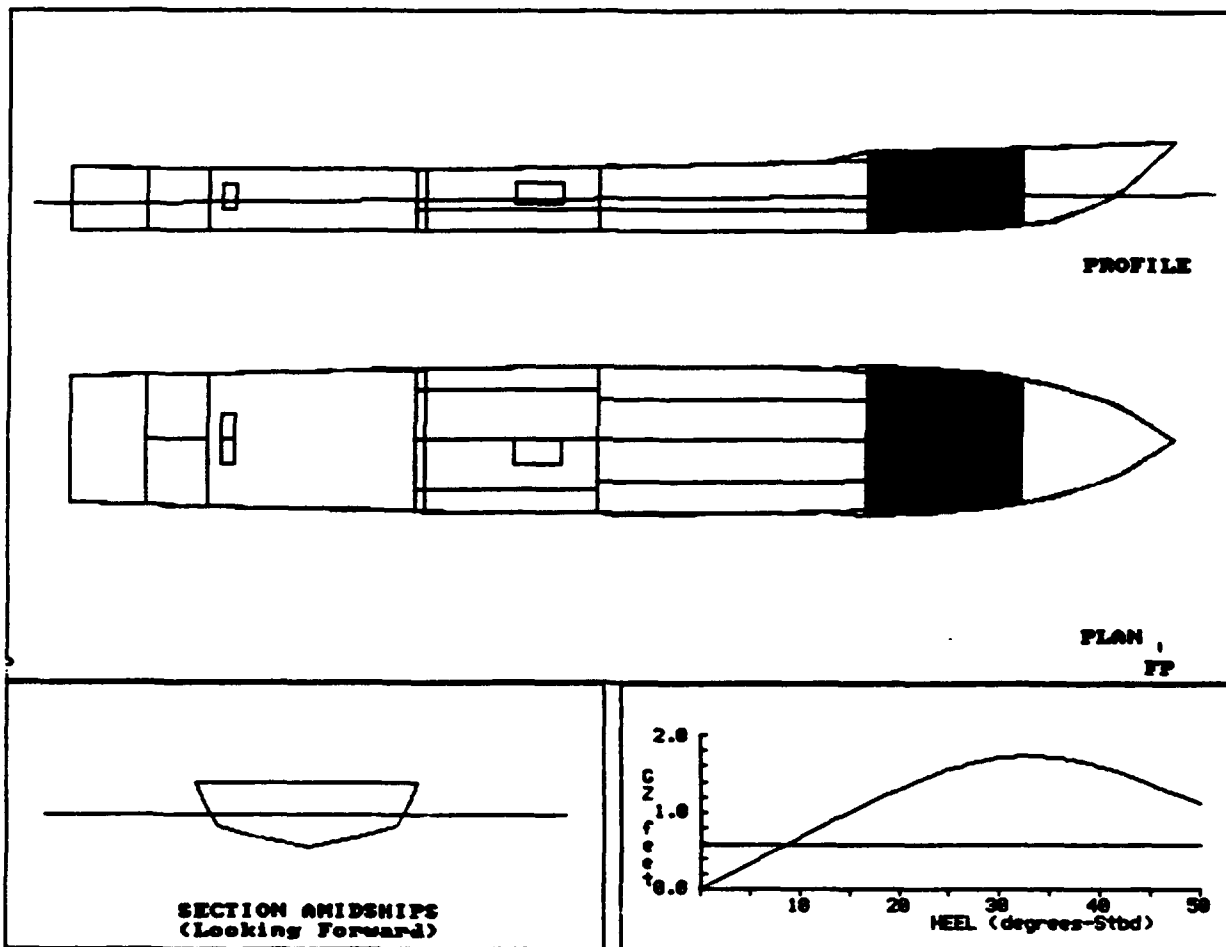

RTRN002B: COLL2
 122' CREW BOAT

COMPARTMENT FLOODING SUMMARY

At 0.0o Heel	PERM.	FLOODED WTR LTons	% FULL (Damaged)	% FULL (Intact)	SP.VOL. ft3/LT	OUTFLOW LTons
GALLEY	0.95	16.5	FREE	0.0	----	----
Totals		16.5				

INTACT DATA

Draft at AP = 4.875 ft	Kmt = 11.923 ft	LCG = 70.578A ft-FP
Draft at FP = 4.520 ft	VCG = 8.200 ft	LCB = 70.593A ft-FP
Displacement = 162.9 LTons	Gmt = 3.723 ft	TCG = 0.000 ft-CL

DRAFT/GZ DATA

HEEL degrees	RIGHTING ARM ft	DRAFT AFT ft	DRAFT FWD ft	FLOODED WATER LTons
0.00	0.000	4.218	5.984	16.5
5.00S	0.327	4.210	5.964	16.5
7.00S	0.460	4.201	5.948	16.5
10.00S	0.666	4.188	5.903	16.5
20.00S	1.296	4.016	5.633	16.5
30.00S	1.706	3.530	5.086	16.4
40.00S	1.597	2.842	4.474	18.3
50.00S	1.109	2.079	3.561	20.2

Note: Drafts are measured at A.P. and F.P along ship's centerline

GZ SUMMARY (Evaluated per IMO (SOLAS'90) Rules for Passenger Ships)
 Available Required

Static Heel Angle	0.00 deg	7.00 deg
Angle at Maximum GZ	34.00S deg	
Maximum GZ	1.731 ft	0.560 ft
Range of Positive GZ	50.00 deg	15.00 deg
Gmt (upright damaged)	3.724 ft	
Righting Area (0.00- $\frac{1}{2}$.00)	15.900 ft-deg	2.820 ft-deg

RTRN003B: COLL3
 122' CREW BOAT

Damaged Compartments:
 PASS CABIN

	DISPLACEMENT LTons	DRAFT AFT ft	DRAFT FWD ft	TRIM ft	HEEL deg.	UPRIGHT GMT ft
INTACT	162.9	4.875	4.520	0.355A	0.00	3.723
DAMAGED	196.6	4.555	6.284	1.729F	0.00	1.724

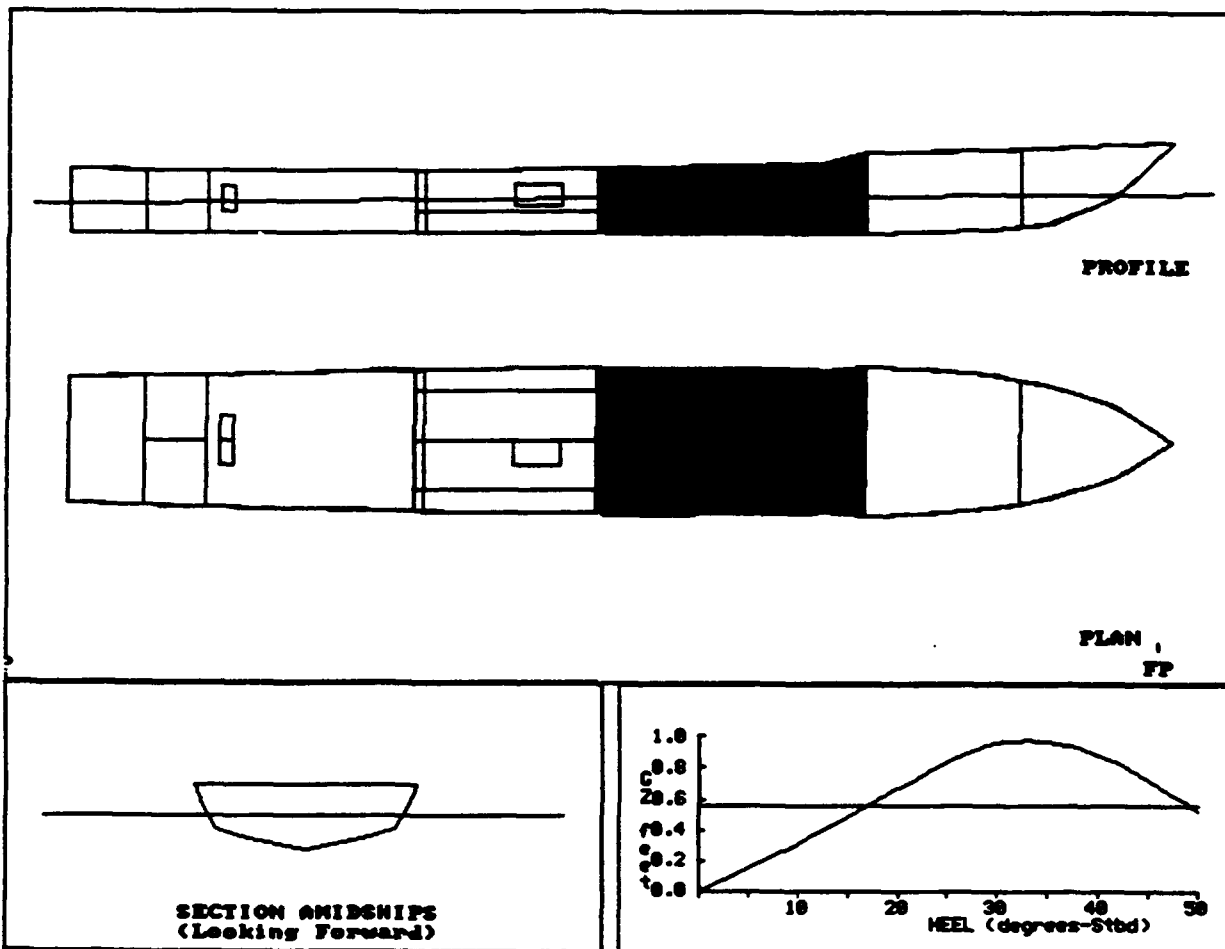

RTRM003B: COLL3
 122' CREW BOAT

COMPARTMENT FLOODING SUMMARY

At 0.0o Heel	PERM.	FLOODED WTR LTons	% FULL (Damaged)	% FULL (Intact)	SP.VOL. ft3/LT	OUTFLOW LTons
PASS CABIN	0.95	33.8	FREE	0.0	----	----
Totals		33.8				

INTACT DATA

Draft at AP = 4.875 ft	KMt = 11.923 ft	LCG = 70.578A ft-FP
Draft at FP = 4.520 ft	VCG = 8.200 ft	LCB = 70.593A ft-FP
Displacement = 162.9 LTons	GMT = 3.723 ft	TCG = 0.000 ft-CL

DRAFT/GZ DATA

HEEL degrees	RIGHTING ARM ft	DRAFT AFT ft	DRAFT FWD ft	FLOODED WATER LTons
0.00	0.000	4.555	6.284	33.8
5.00S	0.151	4.550	6.262	33.7
7.00S	0.213	4.541	6.244	33.8
10.00S	0.310	4.528	6.200	33.7
20.00S	0.664	4.382	5.979	34.6
30.00S	0.952	3.951	5.711	39.2
40.00S	0.882	3.568	5.151	42.0
50.00S	0.525	3.246	4.261	43.8

Note: Drafts are measured at A.P. and F.P along ship's centerline

GZ SUMMARY (Evaluated per IMO (SOLAS'90) Rules for Passenger Ships)

	Available	Required
Static Heel Angle	0.00 deg	7.00 deg
Angle at Maximum GZ	34.00S deg	
Maximum GZ	0.973 ft	0.560 ft
Range of Positive GZ	50.00 deg	15.00 deg
Gmt (upright damaged)	1.724 ft	
Righting Area (0.00-%.00)	7.768 ft-deg	2.820 ft-deg

RTRN004B: COLL4
 122' CREW BOAT

Damaged Compartments:
 GENERATOR RM

	DISPLACEMENT LTons	DRAFT AFT ft	DRAFT FWD ft	TRIM ft	HEEL deg.	UPRIGHT GMT ft
INTACT	162.9	4.875	4.520	0.355A	0.00	3.723
DAMAGED	179.5	5.246	4.773	0.473A	0.10P	2.105

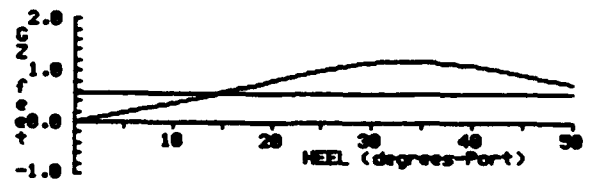
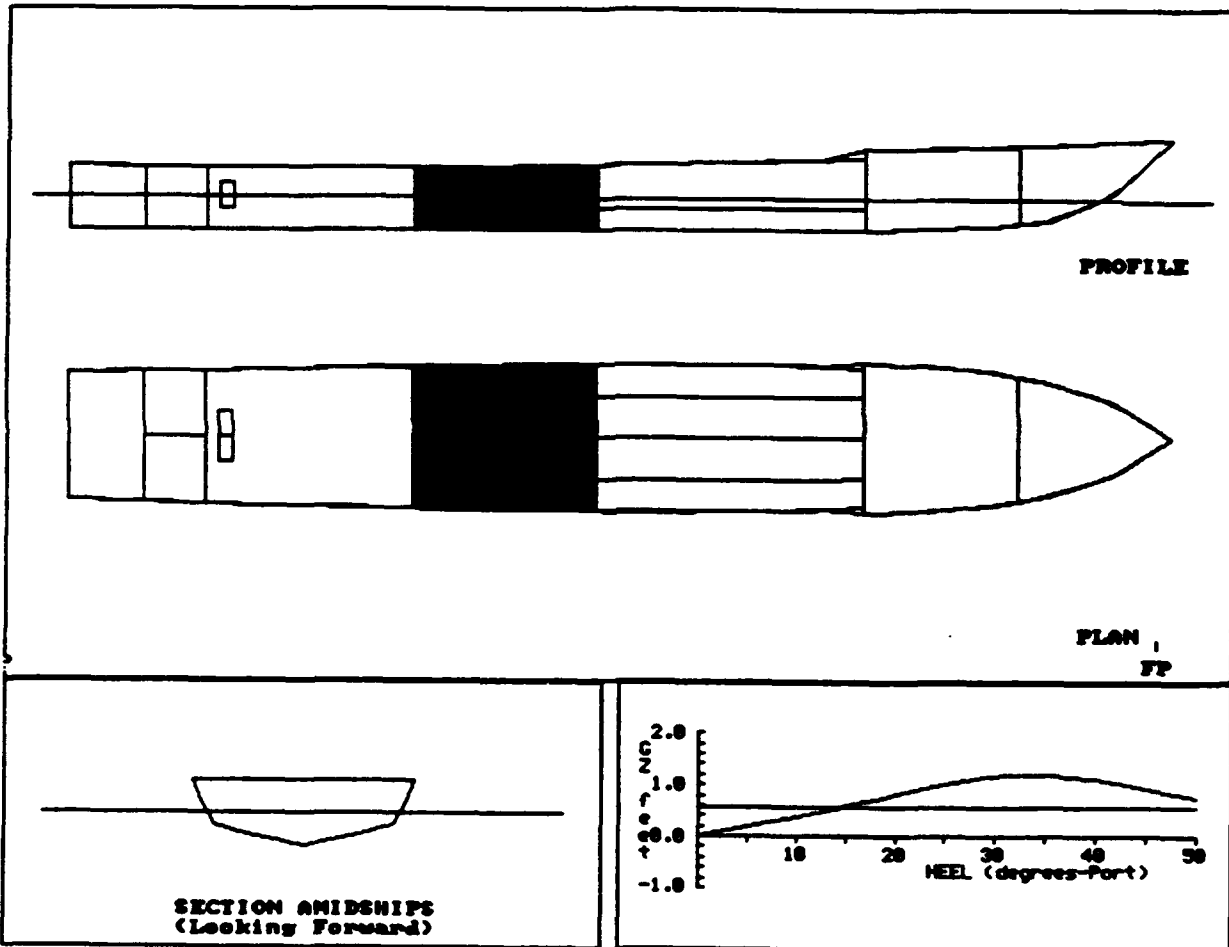

RTRN004B: COLL4
 122' CREW BOAT

COMPARTMENT FLOODING SUMMARY

At 0.10P Heel	PERM.	FLOODED WTR LTons	% FULL (Damaged)	% FULL (Intact)	SP.VOL. ft3/LT	OUTFLOW LTons
GENERATOR RM	0.85	16.6	FREE	0.0	----	----
Totals		16.6				

INTACT DATA

Draft at AP = 4.875 ft	KMt = 11.923 ft	LCG = 70.578A ft-FP
Draft at FP = 4.520 ft	VCG = 8.200 ft	LCB = 70.593A ft-FP
Displacement = 162.9 LTons	GMT = 3.723 ft	TCG = 0.000 ft-CL

DRAFT/GZ DATA

HEEL degrees	RIGHTING ARM ft	DRAFT AFT ft	DRAFT FWD ft	FLOODED WATER LTons
0.00	-0.004	5.246	4.773	16.6
5.00P	0.180	5.245	4.750	16.7
7.00P	0.255	5.239	4.732	16.8
10.00P	0.370	5.233	4.679	16.8
20.00P	0.810	5.146	4.393	18.6
30.00P	1.169	4.904	3.798	21.7
40.00P	1.103	4.789	2.776	23.6
50.00P	0.733	4.909	1.108	24.8

Note: Drafts are measured at A.P. and F.P along ship's centerline

GZ SUMMARY (Evaluated per IMO (SOLAS'90) Rules for Passenger Ships)
 Available Required

Static Heel Angle	0.10P deg	7.00 deg
Angle at Maximum GZ	34.00P deg	
Maximum GZ	1.197 ft	0.560 ft
Range of Positive GZ	49.90 deg	15.00 deg
Righting Area (0.10-3.00)	9.373 ft-deg	2.820 ft-deg

RTRN005B: COLL5
 122' CREW BOAT

Damaged Compartments:
 ENGINE ROOM

	DISPLACEMENT LTons	DRAFT AFT ft	DRAFT FWD ft	TRIM ft	HEEL deg.	UPRIGHT GMT ft
INTACT	162.9	4.875	4.520	0.355A	0.00	3.723
DAMAGED	217.0	7.559	3.509	4.050A	0.00	2.827

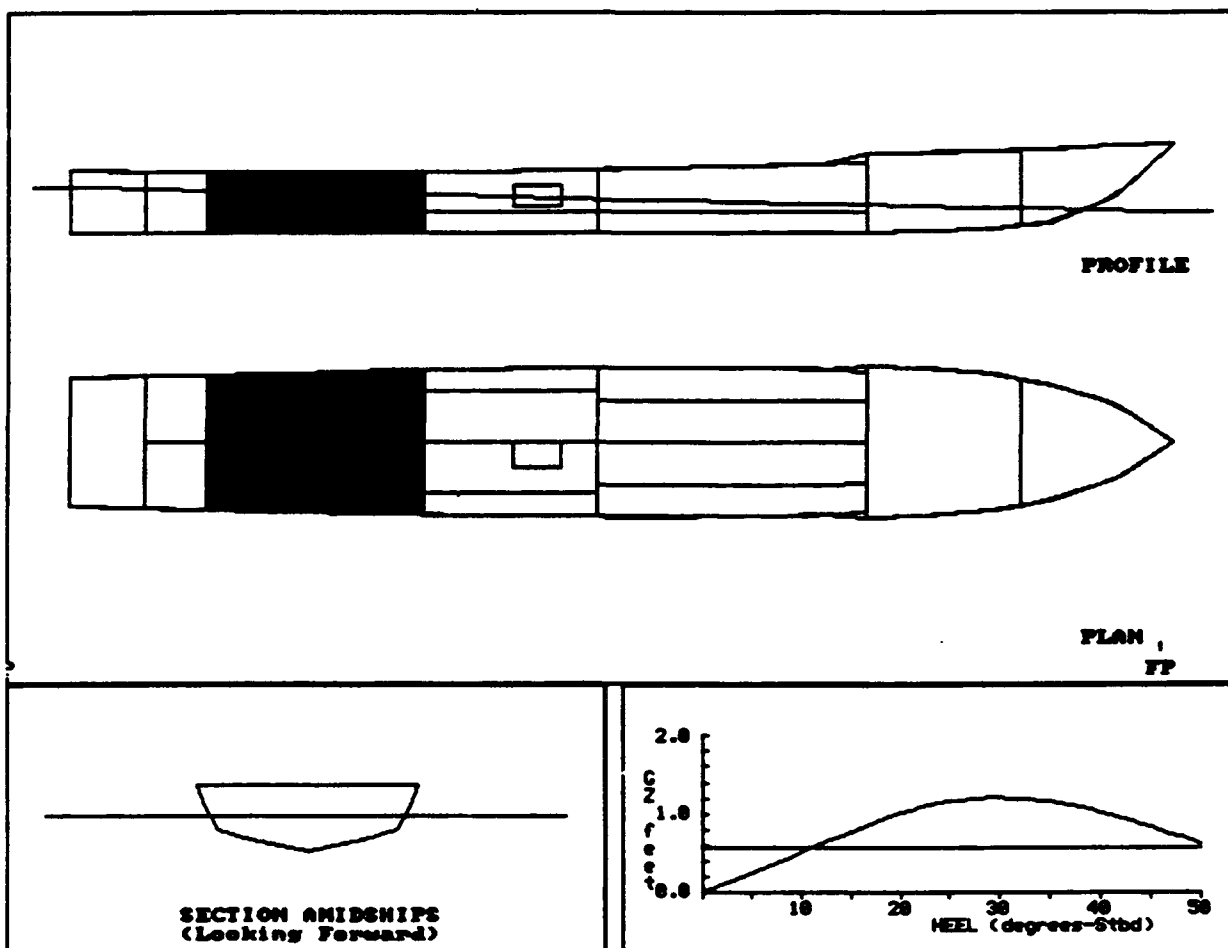

RTRN005B: COLL5
 122' CREW BOAT

COMPARTMENT FLOODING SUMMARY

At 0.0o Heel	PERM.	FLOODED WTR LTons	% FULL (Damaged)	% FULL (Intact)	SP.VOL. ft3/LT	OUTFLOW LTons
ENGINE ROOM	0.85	54.1	FREE	0.0	----	----
Totals		54.1				

INTACT DATA

Draft at AP = 4.875 ft	KMT = 11.923 ft	LCG = 70.578A ft-FP
Draft at FP = 4.520 ft	VCG = 8.200 ft	LCB = 70.593A ft-FP
Displacement = 162.9 LTons	Gmt = 3.723 ft	TCG = 0.000 ft-CL

DRAFT/GZ DATA

HEEL degrees	RIGHTING ARM ft	DRAFT AFT ft	DRAFT FWD ft	FLOODED WATER LTons
0.00	0.000	7.559	3.509	54.1
5.00S	0.249	7.561	3.480	54.2
7.00S	0.351	7.556	3.458	54.2
10.00S	0.507	7.532	3.424	54.1
20.00S	1.010	7.512	3.044	54.1
30.00S	1.203	7.845	2.086	53.4
40.00S	1.022	8.632	0.594	53.0
50.00S	0.622	9.986	-1.696	53.0

Note: Drafts are measured at A.P. and F.P along ship's centerline

GZ SUMMARY (Evaluated per IMO (SOLAS'90) Rules for Passenger Ships)
 Available Required

Static Heel Angle	0.00 deg	7.00 deg
Angle at Maximum GZ	31.00S deg	
Maximum GZ	1.203 ft	0.560 ft
Range of Positive GZ	50.00 deg	15.00 deg
Gmt (upright damaged)	2.827 ft	
Righting Area (0.00-%.00)	12.302 ft-deg	2.820 ft-deg

RTRN006B: COLL6
122' CREW BOAT

Damaged Compartments:
BALLAST STD

	DISPLACEMENT LTons	DRAFT AFT ft	DRAFT FWD ft	TRIM ft	HEEL deg.	UPRIGHT GMT ft
INTACT	162.9	4.875	4.520	0.355A	0.00	3.723
DAMAGED	169.5	5.343	4.220	1.123A	2.45S	3.557

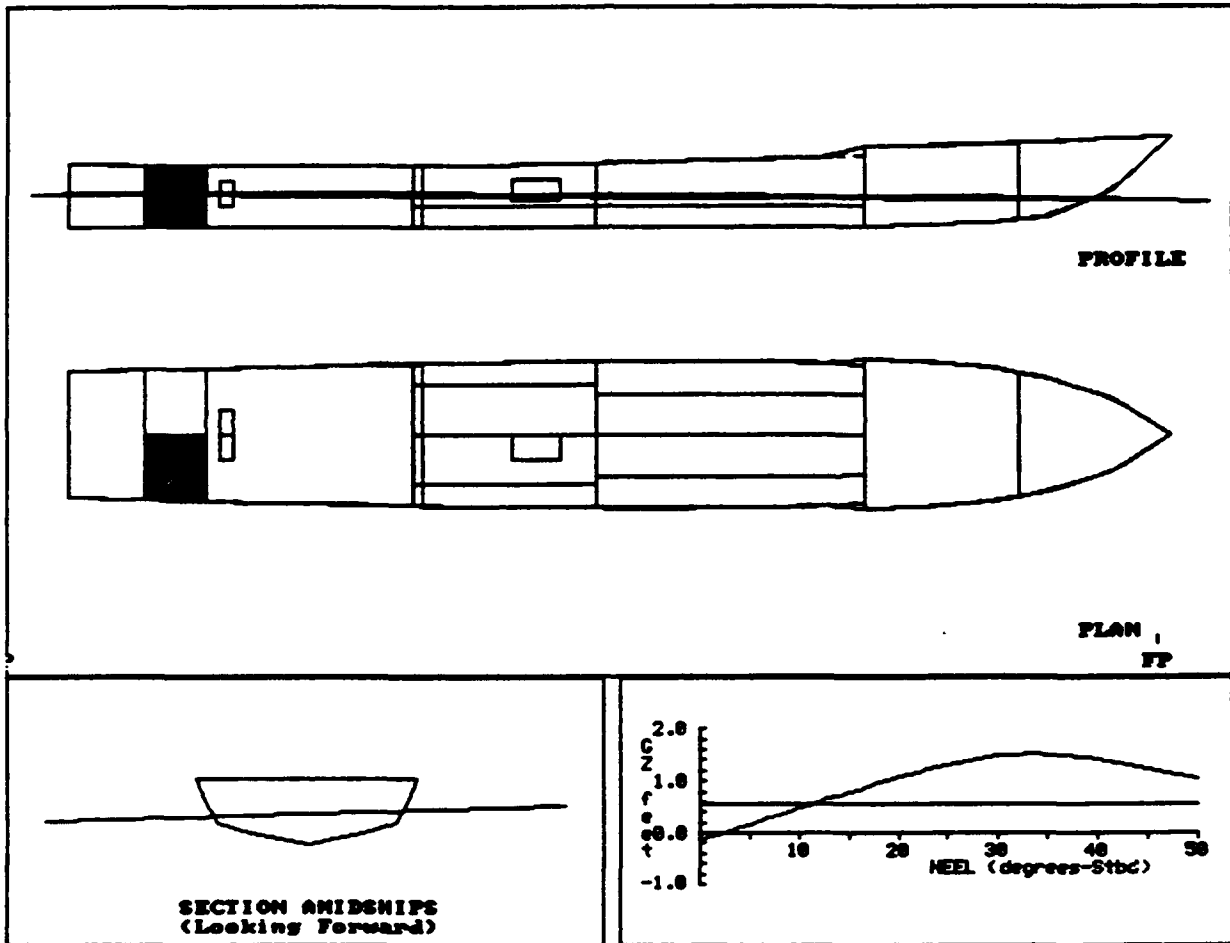

RTRM007B: COLL7
 122' CREW BOAT

Damaged Compartments:
 LAZARETTE

	DISPLACEMENT LTons	DRAFT AFT ft	DRAFT FWD ft	TRIM ft	HEEL deg.	UPRIGHT GMT ft
INTACT	162.9	4.875	4.520	0.355A	0.00	3.723
DAMAGED	181.5	6.386	3.453	2.933A	0.00	3.430

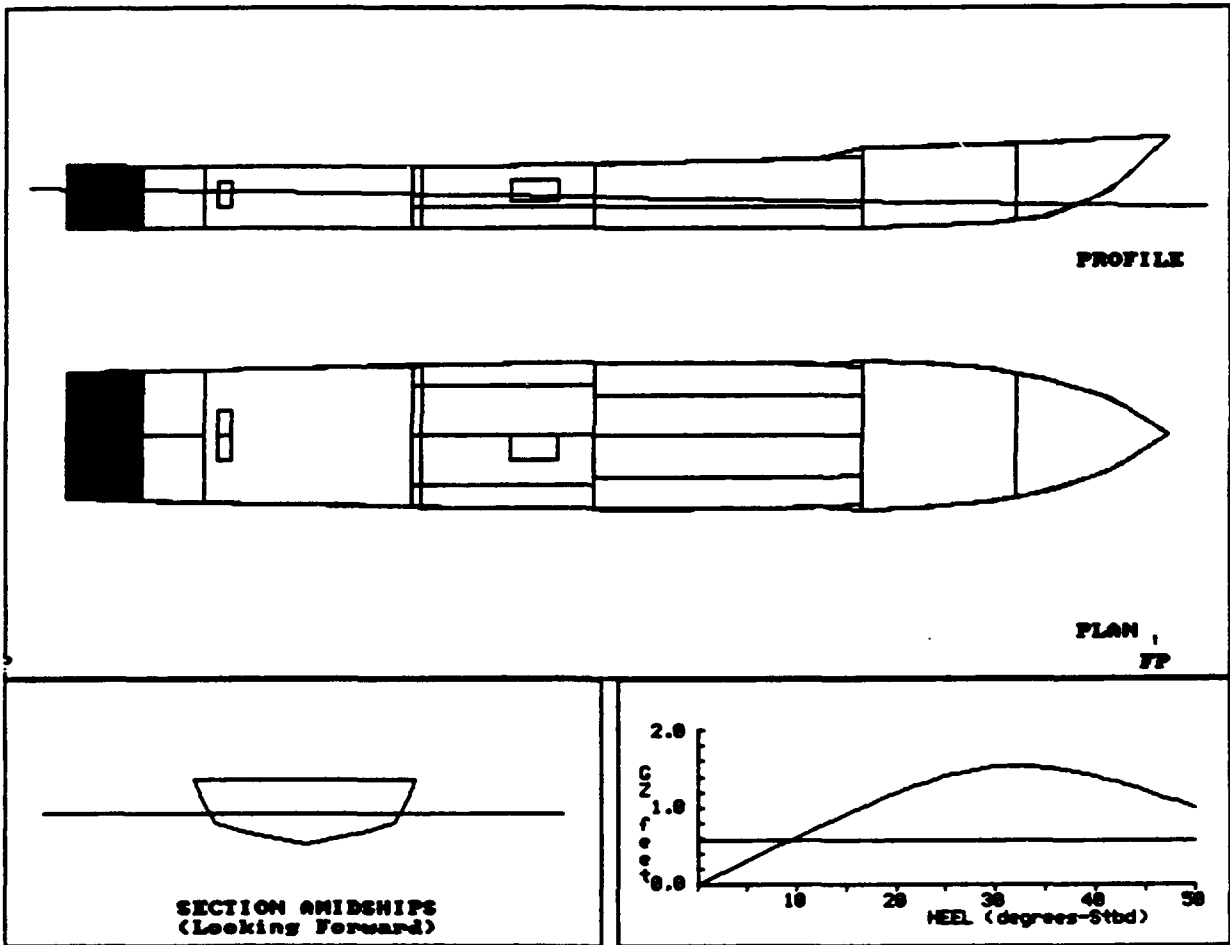

RTRN007B: COLL7
122' CREW BOAT

COMPARTMENT FLOODING SUMMARY

At 0.0o Heel	PERM.	FLOODED WTR LTons	% FULL (Damaged)	% FULL (Intact)	SP.VOL. ft3/LT	OUTFLOW LTons
LAZARETTE	0.95	18.6	FREE	0.0	----	----
Totals		18.6				

INTACT DATA

Draft at AP = 4.875 ft	KMt = 11.923 ft	LCG = 70.578A ft-FP
Draft at FP = 4.520 ft	VCG = 8.200 ft	LCB = 70.593A ft-FP
Displacement = 162.9 LTons	Gmt = 3.723 ft	TCG = 0.000 ft-CL

DRAFT/GZ DATA

HEEL degrees	RIGHTING ARM ft	DRAFT AFT ft	DRAFT FWD ft	FLOODED WATER LTons
0.00	0.000	6.386	3.453	18.6
5.00S	0.301	6.400	3.405	18.6
7.00S	0.422	6.398	3.379	18.7
10.00S	0.604	6.375	3.340	18.6
20.00S	1.182	6.310	2.933	18.7
30.00S	1.526	6.192	2.111	18.4
40.00S	1.405	6.362	0.716	18.4
50.00S	0.990	6.925	-1.520	18.7

Note: Drafts are measured at A.P. and F.P along ship's centerline

GZ SUMMARY (Evaluated per IMO (SOLAS'90) Rules for Passenger Ships)

	Available	Required
Static Heel Angle	0.00 deg	7.00 deg
Angle at Maximum GZ	33.00S deg	
Maximum GZ	1.539 ft	0.560 ft
Range of Positive GZ	50.00 deg	15.00 deg
Gmt (upright damaged)	3.430 ft	
Righting Area (0.00-%.00)	14.483 ft-deg	2.820 ft-deg

RTRN008B: COLLS
 122' CREW BOAT

Damaged Compartments:
 LAZARETTE BALLAST STD

	DISPLACEMENT LTons	DRAFT AFT ft	DRAFT FWD ft	TRIM ft	HEEL deg.	UPRIGHT GMT ft
INTACT	162.9	4.875	4.520	0.355A	0.00	3.723
DAMAGED	193.7	7.282	2.827	4.455A	3.80S	3.311

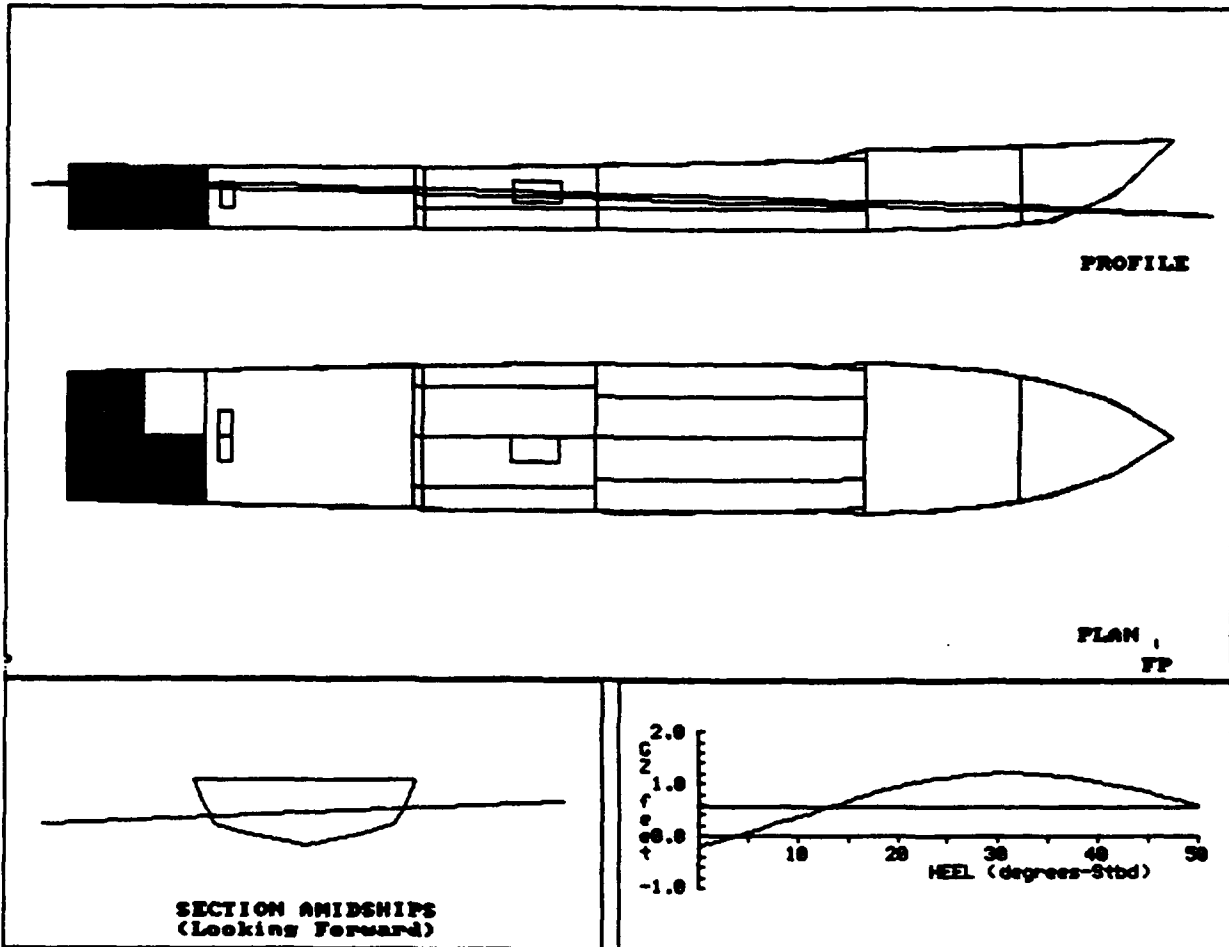

RTRM008B: COLLS
 122' CREW BOAT

COMPARTMENT FLOODING SUMMARY

At 3.8oS Heel	PERM.	FLOODED WTR LTons	% FULL (Damaged)	% FULL (Intact)	SP.VOL. ft3/LT	OUTFLOW LTons
LAZARETTE	0.95	21.6	FREE	0.0	----	----
BALLAST STBD	0.95	9.2	FREE	0.0	----	----
Totals		30.8				

INTACT DATA

Draft at AP = 4.875 ft Kmt = 11.923 ft LCG = 70.578A ft-FP
 Draft at FP = 4.520 ft VCG = 8.200 ft LCB = 70.593A ft-FP
 Displacement = 162.9 LTons GMT = 3.723 ft TCG = 0.000 ft-CL

DRAFT/GZ DATA

HEEL degrees	RIGHTING ARM ft	DRAFT AFT ft	DRAFT FWD ft	FLOODED WATER LTons
0.00	-0.220	7.233	2.873	30.0
5.00S	0.070	7.302	2.801	31.1
7.00S	0.187	7.344	2.740	31.6
10.00S	0.364	7.380	2.655	32.3
20.00S	0.944	7.529	2.097	34.6
30.00S	1.213	7.962	0.959	35.8
40.00S	1.047	8.873	-0.848	36.7
50.00S	0.604	10.433	-3.642	37.5

Note: Drafts are measured at A.P. and F.P along ship's centerline

GZ SUMMARY (Evaluated per IMO (SOLAS'90) Rules for Passenger Ships)
 Available Required

Static Heel Angle	3.80S deg	7.00 deg
Angle at Maximum GZ	32.00S deg	
Maximum GZ	1.215 ft	0.560 ft
Range of Positive GZ	46.20 deg	15.00 deg
Righting Area (3.80-3.00)	9.750 ft-deg	2.820 ft-deg

RTRN009B: GROUND1
 122' CREW BOAT

amaged Compartments:
 PASS CABIN FO TANK S

	DISPLACEMENT LTons	DRAFT AFT ft	DRAFT FWD ft	TRIM ft	HEEL deg.	UPRIGHT GMT ft
INTACT	162.9	4.875	4.520	0.355A	0.00	3.723
DAMAGED	214.8	4.408	7.133	2.725F	4.83S	2.221

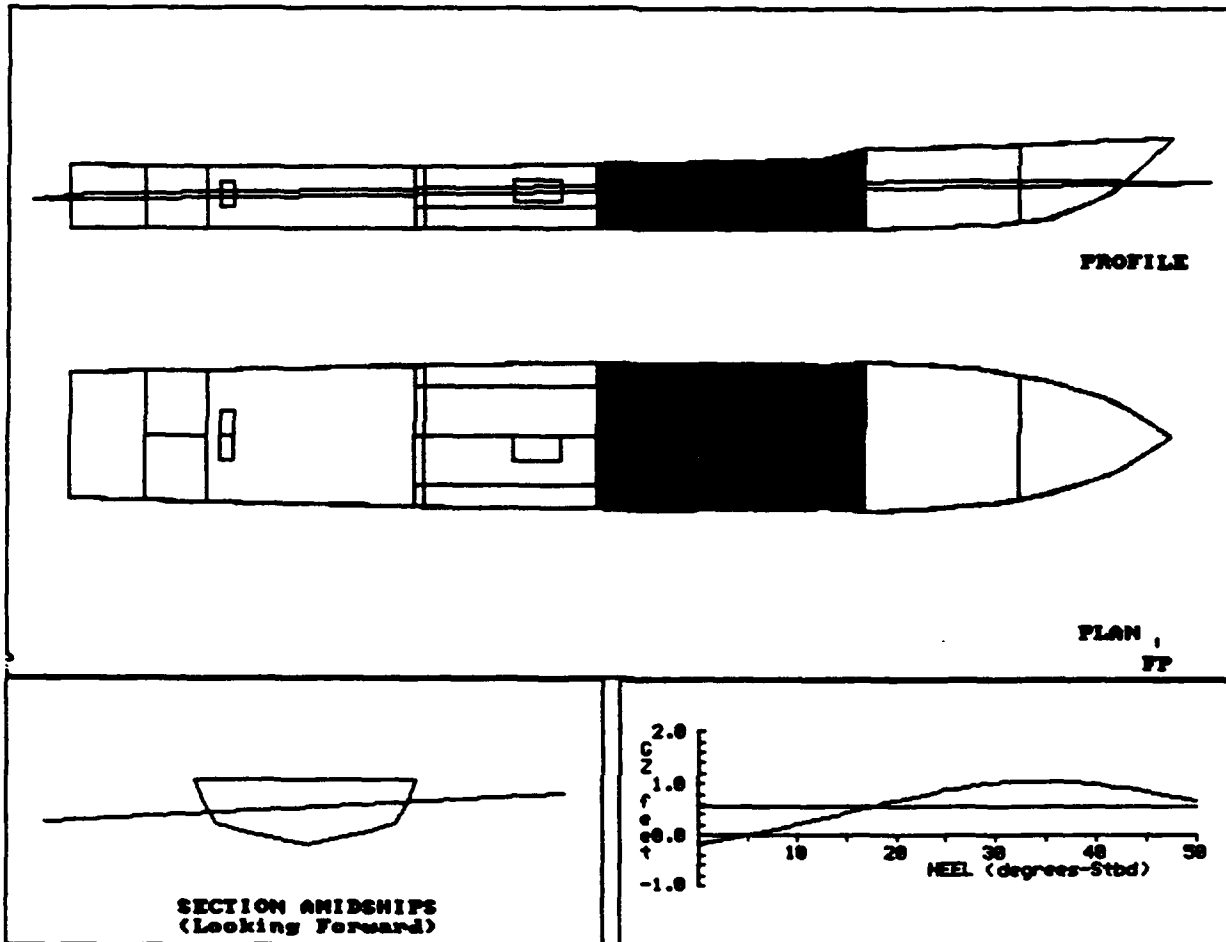

RTRN009B: GROUND1
 122' CREW BOAT

COMPARTMENT FLOODING SUMMARY

At 4.80S Heel	PERM.	FLOODED WTR LTons	% FULL (Damaged)	% FULL (Intact)	SP.VOL. ft ³ /LT	OUTFLOW LTons
PASS CABIN	0.95	41.2	FREE	0.0	----	----
FO TANK S	0.95	11.7	FREE	10.0	40.6000	1.0
Totals		53.0				1.0

INTACT DATA

Draft at AP = 4.875 ft KMT = 11.923 ft LCG = 70.578A ft-FP
 Draft at FP = 4.520 ft VCG = 8.200 ft LCB = 70.593A ft-FP
 Displacement = 162.9 LTons GMT = 3.723 ft TCG = 0.000 ft-CL

DRAFT/GZ DATA

HEEL degrees	RIGHTING ARM ft	DRAFT AFT ft	DRAFT FWD ft	FLOODED WATER LTons
0.00	-0.188	4.414	7.153	53.0
5.00S	0.007	4.407	7.132	53.0
7.00S	0.087	4.399	7.114	53.0
10.00S	0.211	4.385	7.072	53.0
20.00S	0.669	4.255	6.832	53.2
30.00S	1.020	3.886	6.501	55.6
40.00S	1.000	3.574	5.978	57.4
50.00S	0.674	3.294	5.283	58.8

Note: Drafts are measured at A.P. and F.P along ship's centerline

GZ SUMMARY (Evaluated per IMO (SOLAS'90) Rules for Passenger Ships)
 Available Required

Static Heel Angle	4.83S deg	7.00 deg
Angle at Maximum GZ	35.00S deg	
Maximum GZ	1.061 ft	0.560 ft
Range of Positive GZ	45.17 deg	15.00 deg
Righting Area (4.83-7.00)	6.345 ft-deg	2.820 ft-deg

RTRN010B: GROUND2
 122' CREW BOAT

Damaged Compartments:
 GENERATOR RM PO TANK ST

	DISPLACEMENT LTons	DRAFT AFT ft	DRAFT FWD ft	TRIM ft	HEEL deg.	UPRIGHT Gmt ft
INTACT	162.9	4.875	4.520	0.355A	0.00	3.723
DAMAGED	190.9	5.499	4.917	0.582A	4.65S	2.456

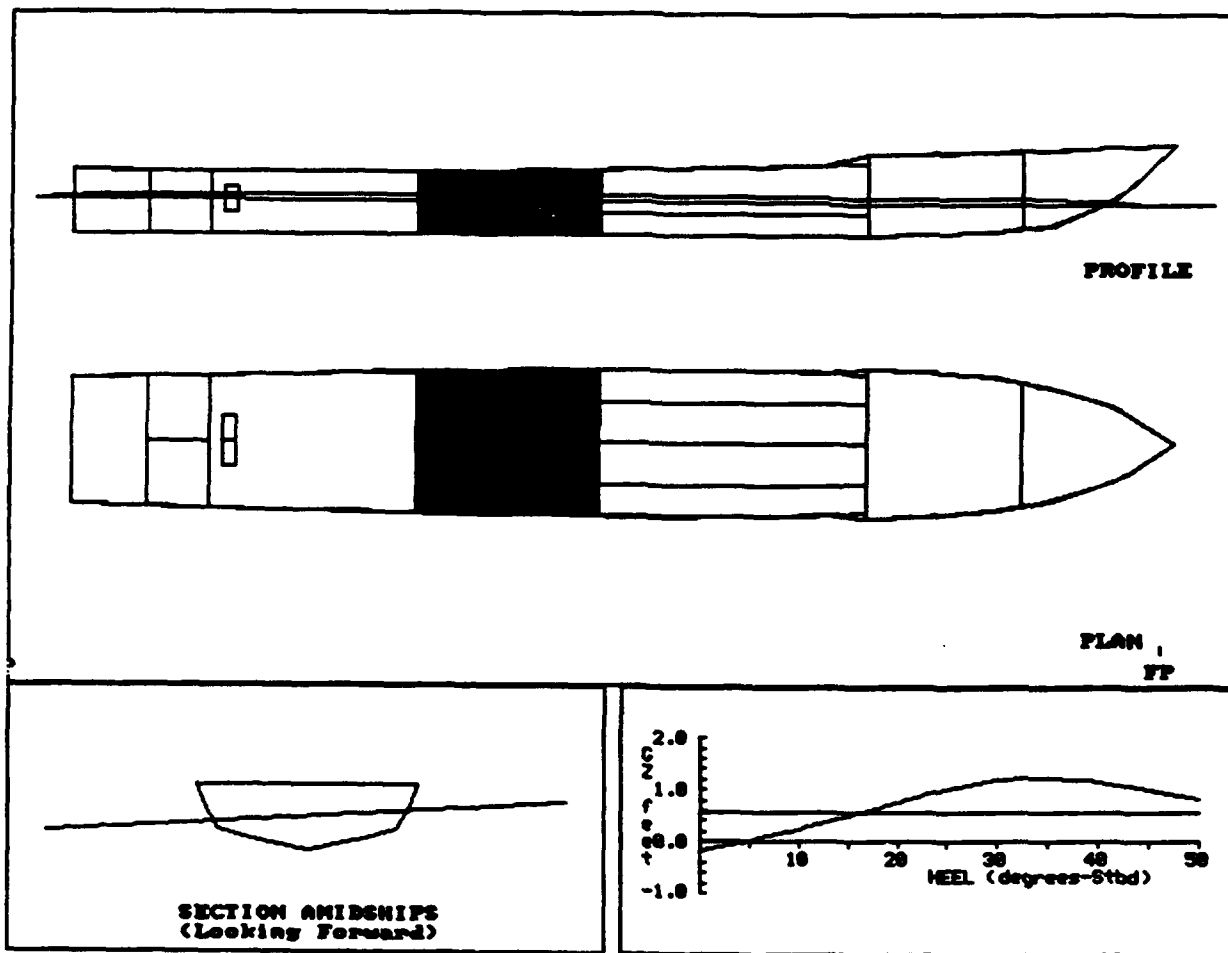

RTRN010B: GROUND2
 122' CREW BOAT

COMPARTMENT FLOODING SUMMARY

At 4.6oS Heel	PERM.	FLOODED WTR LTons	% FULL (Damaged)	% FULL (Intact)	SP.VOL. ft3/LT	OUTFLOW LTons
GENERATOR RM	0.85	18.5	FREE	0.0	----	----
FO TNK2 ST	0.95	10.3	FREE	10.0	40.6000	0.9
Totals		28.9				0.9

INTACT DATA

Draft at AP = 4.875 ft	Kmt = 11.923 ft	LCG = 70.578A ft-FP
Draft at FP = 4.520 ft	VCG = 8.200 ft	LCB = 70.593A ft-FP
Displacement = 162.9 LTons	Gmt = 3.723 ft	TCG = 0.000 ft-CL

DRAFT/GZ DATA

HEEL degrees	RIGHTING ARM ft	DRAFT AFT ft	DRAFT FWD ft	FLOODED WATER LTons
0.00	-0.201	5.503	4.941	29.0
5.00S	0.015	5.498	4.915	28.9
7.00S	0.104	5.489	4.897	28.8
10.00S	0.241	5.481	4.844	28.8
20.00S	0.758	5.386	4.562	29.9
30.00S	1.189	5.217	3.956	32.7
40.00S	1.152	5.254	2.916	34.4
50.00S	0.804	5.545	1.272	35.6

Note: Drafts are measured at A.P. and F.P along ship's centerline

GZ SUMMARY (Evaluated per IMO (SOLAS'90) Rules for Passenger Ships)
 Available Required

Static Heel Angle	4.65S deg	7.00 deg
Angle at Maximum GZ	35.00S deg	
Maximum GZ	1.233 ft	0.560 ft
Range of Positive GZ	45.35 deg	15.00 deg
Righting Area (4.65-7.00)	7.204 ft-deg	2.820 ft-deg

**APPENDIX B
HYDROSTATICS AND
DAMAGE STABILITY
OUTPUT**

180' CRUISE BOAT, W/LIFEBOATS

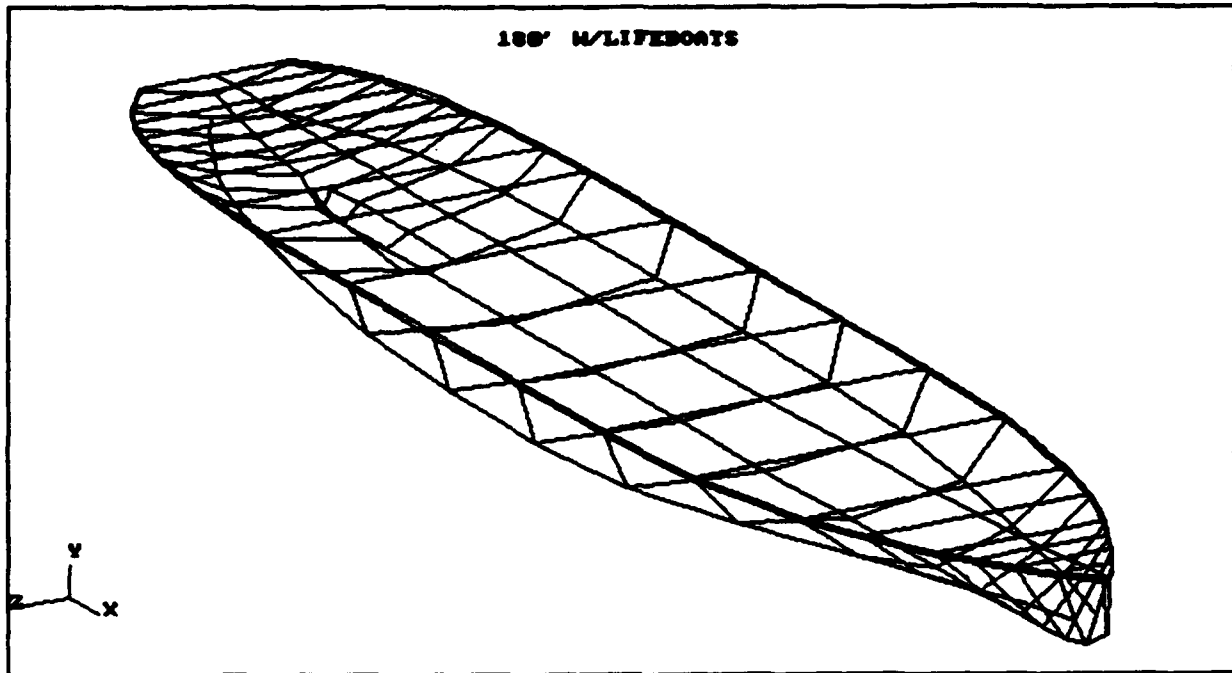

**DAMAGE STABILITY SUMMARY
 180'ER W/LIFEBTS**

ASE No.	FILE NAME	DAMAGED COMP. LISTING	---Intact Condition---			-----Equilibrium Condition After Damage-----					
			MW.DRAFT (ft)	VCG (ft)	GMT (ft)	HEEL (deg)	MAX.GZ (ft)	RANGE (deg)	AREA (ft-deg)	DAM.GMT (ft)	SURVIVAL
1	DPRT001A	1	7.509	16.980	5.660	0.0	1.923	37.56	24.28	5.475	Yes
2	DPRT002A	2	7.509	16.980	5.660	0.0	1.882	36.76	23.98	5.474	Yes
3	DPRT003A	3	7.509	16.980	5.660	0.0	1.685	35.59	21.99	5.150	Yes
4	DPRT004A	5	7.509	16.980	5.660	5.1P	1.361	29.08	13.82	----	Yes
5	DPRT005A	7	7.509	16.980	5.660	0.0	0.906	28.50	13.24	3.624	Yes
6	DPRT006A	8	7.509	16.980	5.660	0.0	1.212	31.87	16.94	4.189	Yes
7	DPRT007A	9	7.509	16.980	5.660	0.0	1.148	31.24	16.58	4.310	Yes
8	DPRT008A	10	7.509	16.980	5.660	0.0	1.510	34.44	19.42	4.356	Yes
9	DPRT009A	13	7.509	16.980	5.660	0.0	1.710	35.56	22.20	5.106	Yes
10	DPRT010A	14	7.509	16.980	5.660	0.0	1.908	37.13	24.14	5.436	Yes
11	DPRT011A	10,11	7.509	16.980	5.660	0.2P	1.525	34.24	19.42	----	Yes

DAMAGE STABILITY SUMMARY
180'ER W/LIFEBS

S.	FILE NAME	DAMAGED COMP.	LISTING	---Intact Condition---			-----Equilibrium Condition After Damage-----					
				MIN.DRAFT (ft)	VCG (ft)	GMT (ft)	HEEL (deg)	MAX.GZ (ft)	RANGE (deg)	AREA (ft-deg)	DAM.GMT (ft)	SURVIVAL
1	RTRN001A	1		7.102	17.570	5.756	0.0	1.954	37.33	24.62	5.543	Yes
2	RTRN002A	2		7.102	17.570	5.756	0.0	1.946	36.81	24.52	5.534	Yes
3	RTRN003A	3		7.102	17.570	5.756	0.0	1.781	35.63	22.75	5.193	Yes
4	RTRN004A	5		7.102	17.570	5.756	1.35	1.572	33.32	19.06	----	Yes
5	RTRN005A	7		7.102	17.570	5.756	0.0	0.946	29.11	13.30	3.324	Yes
6	RTRN006A	8		7.102	17.570	5.756	0.0	1.288	32.08	17.24	4.027	Yes
7	RTRN007A	9		7.102	17.570	5.756	0.0	1.237	31.57	17.14	4.185	Yes
8	RTRN008A	10		7.102	17.570	5.756	0.0	1.557	34.34	19.74	4.359	Yes
9	RTRN009A	13		7.102	17.570	5.756	0.0	1.765	35.49	22.70	5.168	Yes
10	RTRN010A	14		7.102	17.570	5.756	0.0	1.936	36.93	24.45	5.514	Yes
11	RTRN011A	10,11		7.102	17.570	5.756	0.45	1.560	33.92	19.66	----	Yes

HYDROSTATIC TABLES

DEPT DRAFT (ft)		3.000	4.000	5.000	6.000	7.000	7.800
SP.MLD.	(LTons-SW)	189.8	303.2	426.6	559.4	699.5	816.7
SP.TOTAL	(LTons-SW)	194.7	309.1	433.7	567.5	708.8	826.9
SP.TOTAL	(LTons-FW)	190.0	301.6	423.1	553.7	691.5	806.7
B	(ft-FP)	92.601A	92.943A	93.470A	94.096A	94.697A	95.164A
B (forebody)	(ft-FP)	65.713A	64.149A	62.949A	61.970A	61.177A	60.633A
B (aftbody)	(ft-FP)	115.589A	117.364A	119.037A	120.632A	122.038A	123.076A
B	(ft-CL)	0.000	0.000	0.000	0.000	0.000	0.000
b	(ft)	1.921	2.510	3.085	3.657	4.225	4.680
bt	(ft)	47.761	33.652	26.698	22.333	19.288	17.542
bt	(ft)	49.682	36.162	29.783	25.990	23.514	22.222
tl	(ft)	643.289	507.705	443.255	395.379	356.619	332.416
tl	(ft)	645.210	510.216	446.340	399.036	360.845	337.095
W	(LTons)	8.97	9.85	10.69	11.39	11.98	12.43
	(ft-LTons)	56.5	71.3	87.5	102.4	115.5	125.7
	(LTons)	0.17	0.22	0.32	0.42	0.51	0.57
CF	(ft-FP)	93.377A	94.006A	95.404A	96.662A	97.607A	98.229A
P. AREA	(ft2)	3,769.7	4,138.6	4,489.5	4,783.8	5,031.9	5,220.7
ETTED SUR.	(ft2)	4,068.8	4,629.7	5,176.1	5,681.2	6,152.2	6,522.8
MX. BEAM	(ft)	36.617	36.988	37.358	37.729	38.099	38.396
ENGTN W.L.	(ft)	166.542	168.692	172.335	176.618	179.868	182.000
b		0.3020	0.3617	0.4072	0.4449	0.4769	0.4997
b (forebody)		0.2788	0.3323	0.3715	0.4027	0.4287	0.4469
b (aftbody)		0.3252	0.3912	0.4429	0.4871	0.5251	0.5525
B		0.6668	0.7252	0.7620	0.7881	0.8080	0.8211
B		0.4529	0.4988	0.5344	0.5646	0.5902	0.6086
mp		0.5139	0.5642	0.6121	0.6522	0.6860	0.7118
it		0.3127	0.3519	0.3928	0.4308	0.4653	0.4941

Assumes: Sea Water at 35.0063 ft3/LT
Fresh Water at 35.8814 ft3/LT
Ship floating at even keel (no heel or trim)

**DPRT001A:
 180'ER W/LIFEBTS**

**Damaged Compartments:
 FOREPEAK**

	DISPLACEMENT LTons	DRAFT AFT ft	DRAFT FWD ft	TRIM ft	HEEL deg.	UPRIGHT GMT ft
INTACT	794.1	8.238	6.780	1.458A	0.00	5.660
DAMAGED	801.4	8.080	7.087	0.993A	0.00	5.475

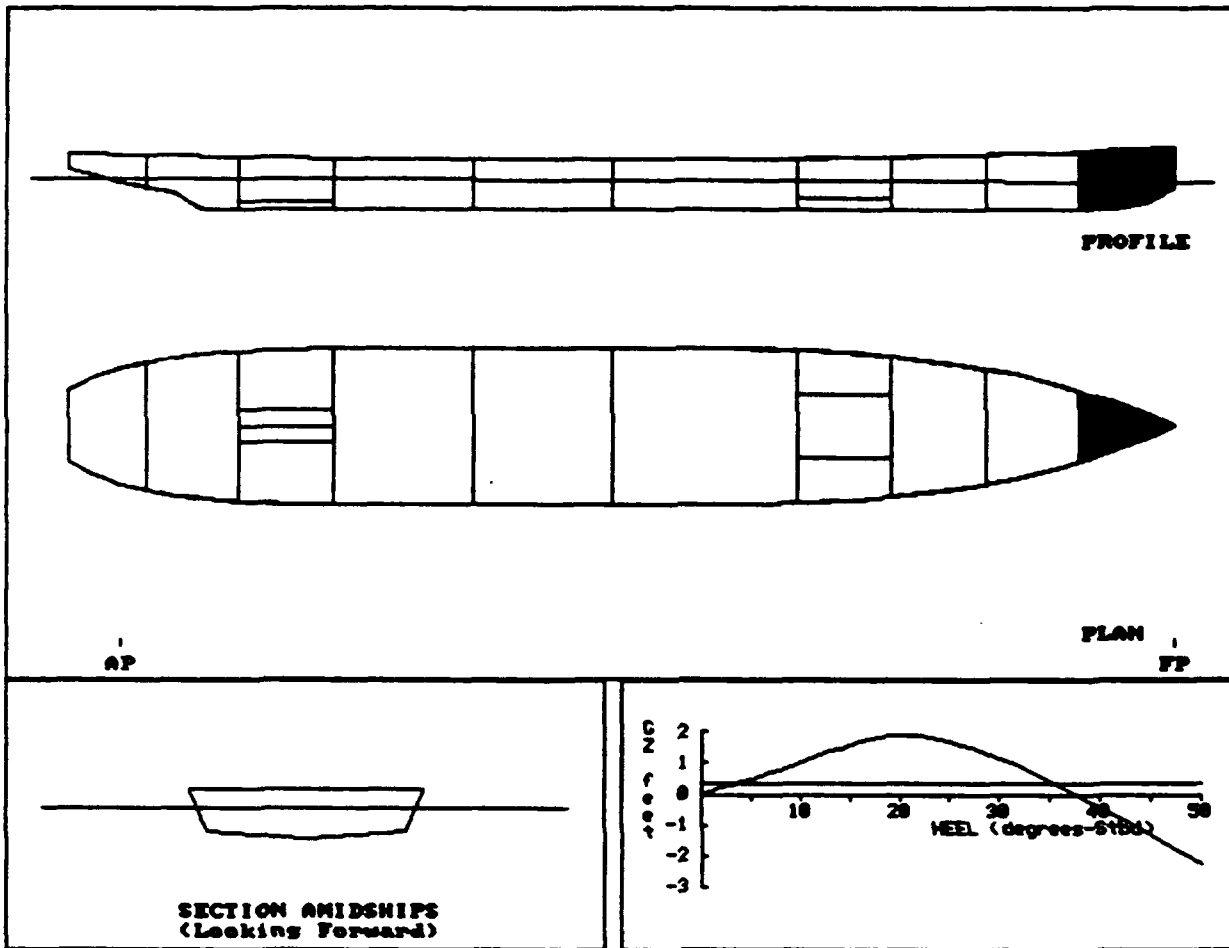

DPRT001A:
 180'ER W/LIFEBTS

COMPARTMENT FLOODING SUMMARY

At 0.0o Heel	PERM.	FLOODED WTR LTons	% FULL (Damaged)	% FULL (Intact)	SP.VOL. ft3/LT	OUTFLOW LTons
FOREPEAK	0.95	7.4	FREE	0.0	----	----
Totals		7.4				

INTACT DATA

Draft at AP = 8.238 ft	KMT = 22.640 ft	LCG = 97.709A ft-FP
Draft at FP = 6.780 ft	VCG = 16.980 ft	LCB = 97.810A ft-FP
Displacement = 794.1 LTons	GMT = 5.660 ft	TCG = 0.000 ft-CL

DRAFT/GZ DATA

HEEL degrees	RIGHTING ARM ft	DRAFT AFT ft	DRAFT FWD ft	FLOODED WATER LTons
0.00	0.000	8.080	7.087	7.4
5.00S	0.485	8.060	7.048	7.3
7.00S	0.687	8.021	7.036	7.3
10.00S	1.008	7.943	6.999	7.2
20.00S	1.923	7.351	6.934	7.2
22.00S	1.885	7.252	6.879	7.1
30.00S	1.150	6.779	6.745	7.1
40.00S	-0.423	6.180	6.528	7.3
50.00S	-2.275	5.433	6.306	8.3

Note: Drafts are measured at A.P. and F.P along ship's centerline

GZ SUMMARY (Evaluated per IMO (SOLAS'90) Rules for Passenger Ships)

	Available	Required
Static Heel Angle	0.00 deg	7.00 deg
Angle at Maximum GZ	21.00S deg	
Maximum GZ	1.923 ft	0.328 ft
Range of Positive GZ	37.56 deg	15.00 deg
Gmt (upright damaged)	5.475 ft	
Righting Area (0.00-%.00)	24.285 ft-deg	2.820 ft-deg

DPR002A:
180'ER W/LIFEBTS

Damaged Compartments:
 VOID1

	DISPLACEMENT LTons	DRAFT AFT ft	DRAFT FWD ft	TRIM ft	HEEL deg.	UPRIGHT GMT ft
INTACT	794.1	8.238	6.780	1.458A	0.00	5.660
DAMAGED	823.2	7.773	7.779	0.006F	0.00	5.474

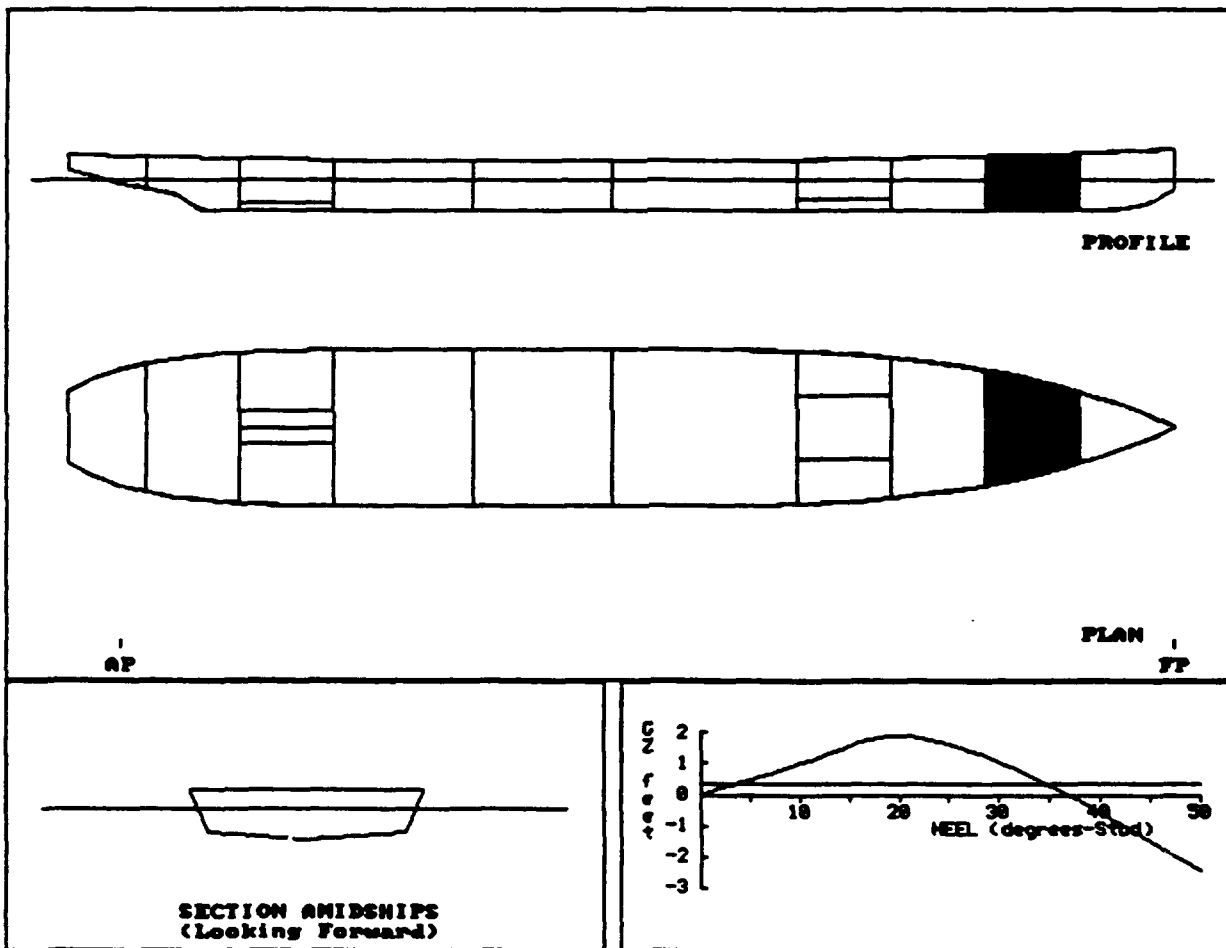

DPRT002A:
 180'ER W/LIFEBTS

COMPARTMENT FLOODING SUMMARY

At 0.0o Heel	PERM.	FLOODED WTR LTons	% FULL (Damaged)	% FULL (Intact)	SP.VOL. ft3/LT	OUTFLOW LTons
VOID1	0.95	29.1	FREE	0.0	----	----
Totals		29.1				

INTACT DATA

Draft at AP = 8.238 ft	KMt = 22.640 ft	LCG = 97.709A ft-FP
Draft at FP = 6.780 ft	VCG = 16.980 ft	LCB = 97.810A ft-FP
Displacement = 794.1 LTons	GMT = 5.660 ft	TCG = 0.000 ft-CL

DRAFT/GZ DATA

HEEL degrees	RIGHTING ARM ft	DRAFT AFT ft	DRAFT FWD ft	FLOODED WATER LTons
0.00	0.000	7.773	7.779	29.1
5.00S	0.484	7.739	7.759	29.1
7.00S	0.686	7.699	7.749	29.2
10.00S	1.004	7.617	7.719	29.3
20.00S	1.882	6.989	7.763	31.3
22.00S	1.836	6.857	7.787	32.2
30.00S	1.052	6.224	8.056	37.1
40.00S	-0.567	5.393	8.458	41.9
50.00S	-2.425	4.371	8.951	44.8

Note: Drafts are measured at A.P. and F.P along ship's centerline

GZ SUMMARY (Evaluated per IMO (SOLAS'90) Rules for Passenger Ships)

	Available	Required
Static Heel Angle	0.00 deg	7.00 deg
Angle at Maximum GZ	21.00S deg	
Maximum GZ	1.882 ft	0.328 ft
Range of Positive GZ	36.76 deg	15.00 deg
Gmt (upright damaged)	5.474 ft	
Righting Area (0.00-7.00)	23.975 ft-deg	2.820 ft-deg

DPR003A:
 180'ER W/LIFEBTS

Imaged Compartments:
 VOID2

	DISPLACEMENT LTons	DRAFT AFT ft	DRAFT FWD ft	TRIM ft	HEEL deg.	UPRIGHT GMT ft
INTACT	794.1	8.238	6.780	1.458A	0.00	5.660
DAMAGED	852.5	7.590	8.423	0.832F	0.00	5.150

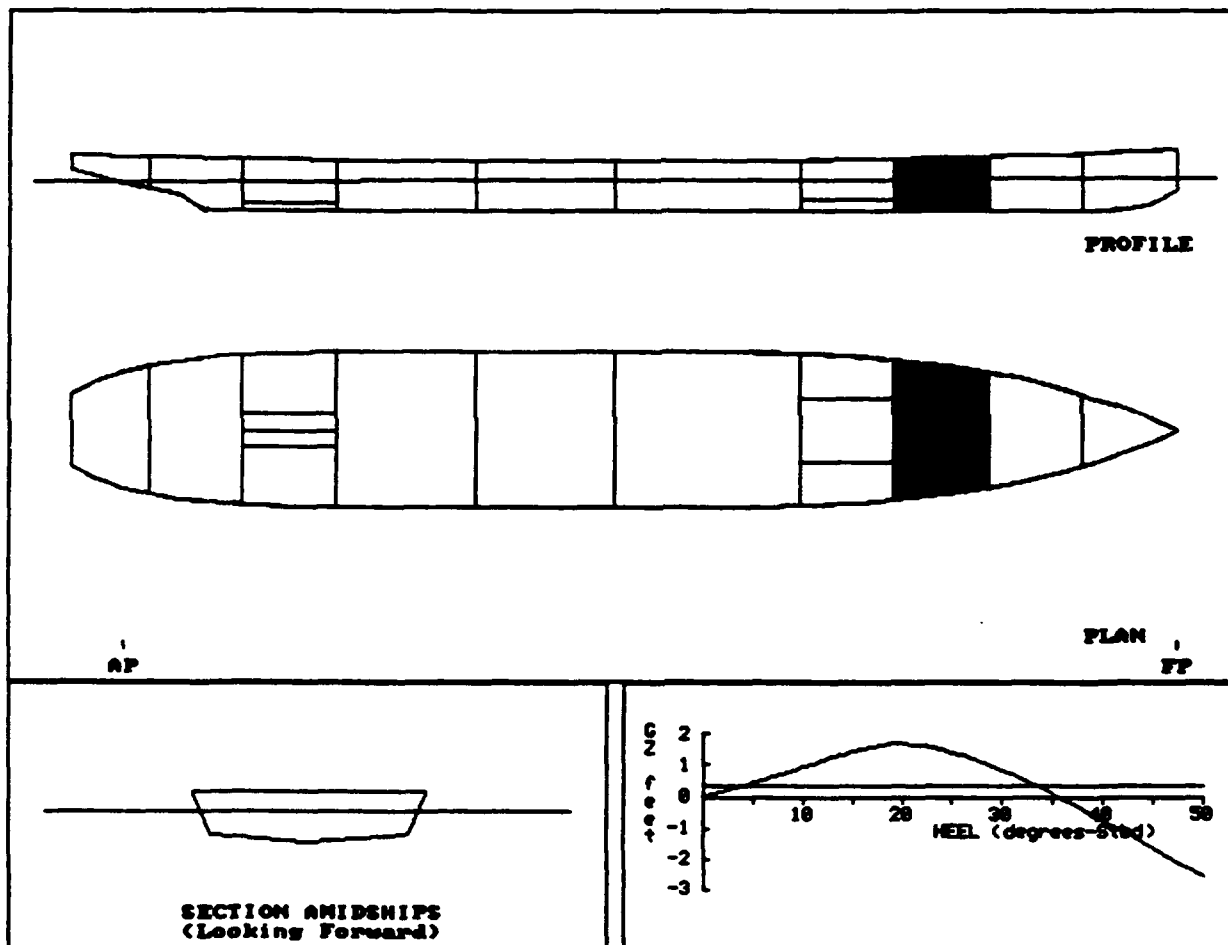

DPRT003A:
 180'ER W/LIFEBTS

COMPARTMENT FLOODING SUMMARY

At 0.0o Heel	PERM.	FLOODED WTR LTons	% FULL (Damaged)	% FULL (Intact)	SP.VOL. ft3/LT	OUTFLOW LTons
VOID2	0.95	58.4	FREE	0.0	----	----
Totals		58.4				

INTACT DATA

Draft at AP = 8.238 ft	KMt = 22.640 ft	LCG = 97.709A ft-FP
Draft at FP = 6.780 ft	VCG = 16.980 ft	LCB = 97.810A ft-FP
Displacement = 794.1 LTons	GMT = 5.660 ft	TCG = 0.000 ft-CL

DRAFT/GZ DATA

HEEL degrees	RIGHTING ARM ft	DRAFT AFT ft	DRAFT FWD ft	FLOODED WATER LTons
0.00	0.000	7.590	8.423	58.4
5.00S	0.455	7.553	8.410	58.6
7.00S	0.645	7.512	8.403	58.9
10.00S	0.944	7.423	8.384	59.3
20.00S	1.685	6.787	8.550	64.6
22.00S	1.623	6.649	8.626	65.8
30.00S	0.836	6.068	8.972	68.9
40.00S	-0.749	5.322	9.425	70.3
50.00S	-2.572	4.386	10.037	70.8

Note: Drafts are measured at A.P. and F.P along ship's centerline

GZ SUMMARY (Evaluated per IMO (SOLAS'90) Rules for Passenger Ships)
 Available Required

Static Heel Angle	0.00 deg	7.00 deg
Angle at Maximum GZ	21.00S deg	
Maximum GZ	1.685 ft	0.328 ft
Range of Positive GZ	35.59 deg	15.00 deg
Gmt (upright damaged)	5.150 ft	
Righting Area (0.00-7.00)	21.995 ft-deg	2.820 ft-deg

DPR004A:
 180'ER W/LIFEBTS

Damaged Compartments:
 FW TANK STBD

	DISPLACEMENT LTons	DRAFT AFT ft	DRAFT FWD ft	TRIM ft	HEEL deg.	UPRIGHT GMT ft
INTACT	794.1	8.238	6.780	1.458A	0.00	5.660
DAMAGED	763.7	8.413	6.038	2.375A	5.14P	4.927

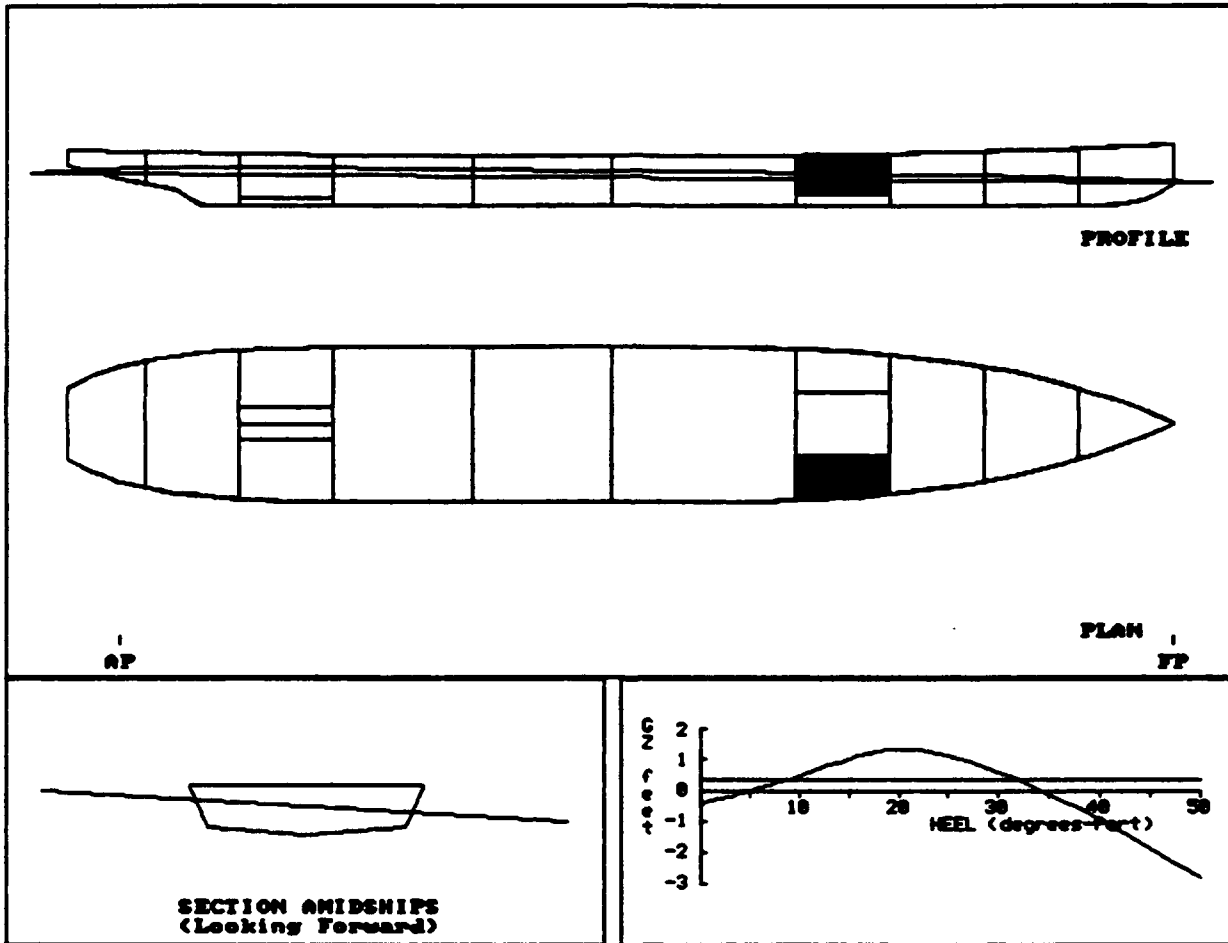

DPRT004A:
 180'ER W/LIFEBS

COMPARTMENT FLOODING SUMMARY

At 5.10P Heel	PERM.	FLOODED WTR LTons	% FULL (Damaged)	% FULL (Intact)	SP.VOL. ft3/LT	OUTFLOW LTons
FW TANK STBD	0.95	7.3	FREE	98.0	34.2000	37.7
Totals		7.3				37.7

INTACT DATA

Draft at AP = 8.238 ft	KMt = 22.640 ft	LCG = 97.709A ft-FP
Draft at FP = 6.780 ft	VCG = 16.980 ft	LCB = 97.810A ft-FP
Displacement = 794.1 LTons	GMT = 5.660 ft	TCG = 0.000 ft-CL

DRAFT/GZ DATA

HEEL degrees	RIGHTING ARM ft	DRAFT AFT ft	DRAFT FWD ft	FLOODED WATER LTons
0.00	-0.452	8.415	6.157	11.0
5.00P	-0.013	8.415	6.040	7.4
7.00P	0.174	8.381	6.003	6.0
10.00P	0.474	8.289	5.957	4.1
20.00P	1.361	7.734	5.710	0.0
22.00P	1.328	7.616	5.631	0.0
30.00P	0.602	7.191	5.239	0.0
40.00P	-0.956	6.670	4.594	0.0
50.00P	-2.789	6.051	3.758	0.0

Note: Drafts are measured at A.P. and F.P along ship's centerline

GZ SUMMARY (Evaluated per IMO (SOLAS'90) Rules for Passenger Ships)
 Available Required

Static Heel Angle	5.14P deg	7.00 deg
Angle at Maximum GZ	21.00P deg	
Maximum GZ	1.361 ft	0.328 ft
Range of Positive GZ	29.08 deg	15.00 deg
Righting Area (5.14-7.00)	13.824 ft-deg	2.820 ft-deg

DPR005A:
 180'ER W/LIFEBTS

Imaged Compartments:
 CREW

	DISPLACEMENT LTons	DRAFT AFT ft	DRAFT FWD ft	TRIM ft	HEEL deg.	UPRIGHT GMT ft
INTACT	794.1	8.238	6.780	1.458A	0.00	5.660
DAMAGED	1,063.3	8.569	10.234	1.664F	0.00	3.624

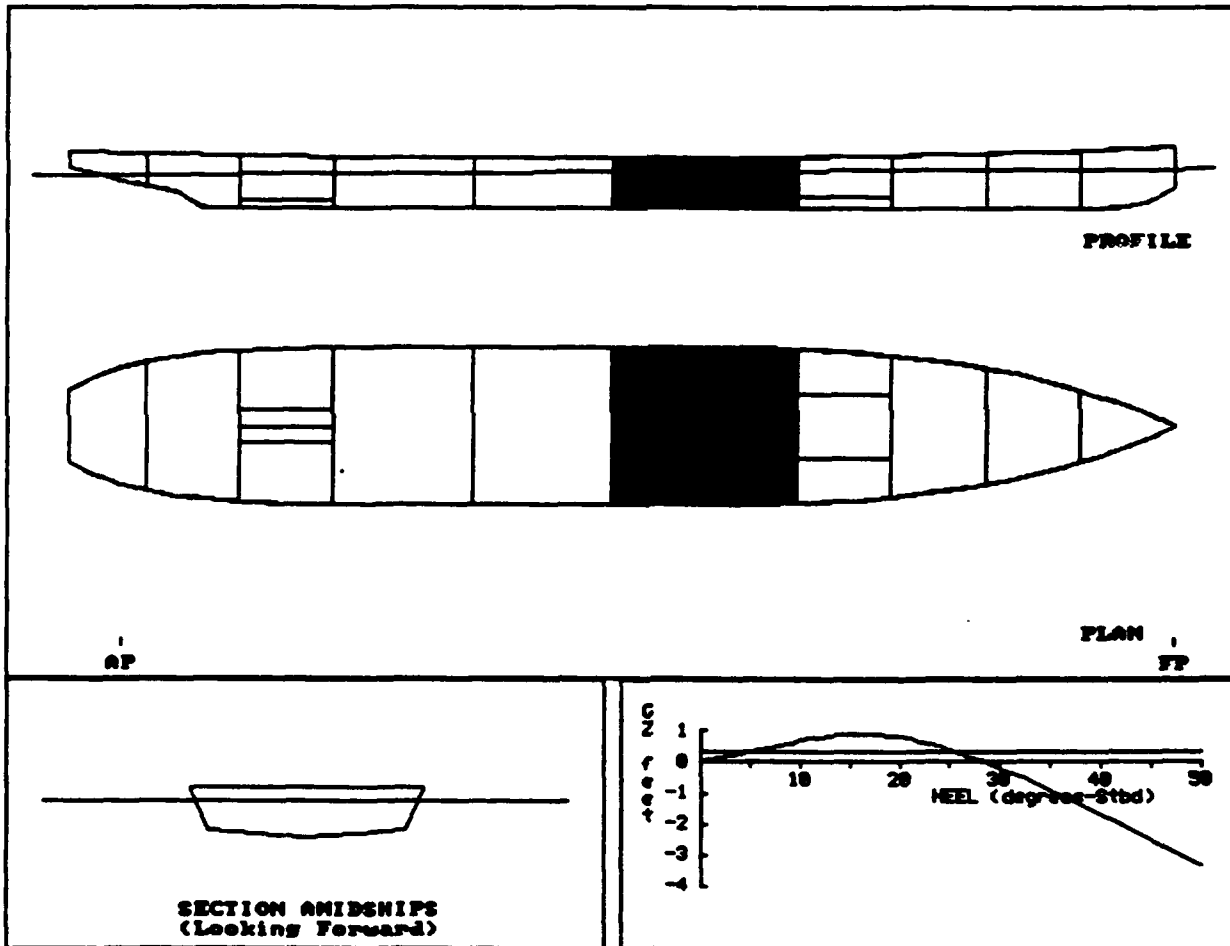

**DPRTO05A:
 180'ER W/LIFEBTS**

COMPARTMENT FLOODING SUMMARY

At 0.0o Heel	PERM.	FLOODED WTR LTons	% FULL (Damaged)	% FULL (Intact)	SP.VOL. ft3/LT	OUTFLOW LTons
CREW	0.95	269.2	FREE	0.0	----	----
Totals		269.2				

INTACT DATA

Draft at AP = 8.238 ft	KMt = 22.640 ft	LCG = 97.709A ft-FP
Draft at FP = 6.780 ft	VCG = 16.980 ft	LCB = 97.810A ft-FP
Displacement = 794.1 LTons	GMT = 5.660 ft	TCG = 0.000 ft-CL

DRAFT/GZ DATA

HEEL degrees	RIGHTING ARM ft	DRAFT AFT ft	DRAFT FWD ft	FLOODED WATER LTons
0.00	0.000	8.569	10.234	269.2
5.00S	0.323	8.528	10.209	268.8
7.00S	0.461	8.490	10.188	268.4
10.00S	0.683	8.408	10.141	267.5
20.00S	0.807	8.136	10.258	255.3
22.00S	0.673	8.106	10.367	252.5
30.00S	-0.193	8.058	10.862	242.1
40.00S	-1.699	8.061	11.681	233.9
50.00S	-3.351	8.192	12.768	228.2

Note: Drafts are measured at A.P. and F.P along ship's centerline

GZ SUMMARY (Evaluated per IMO (SOLAS'90) Rules for Passenger Ships)

	Available	Required
Static Heel Angle	0.00 deg	7.00 deg
Angle at Maximum GZ	17.00S deg	
Maximum GZ	0.906 ft	0.328 ft
Range of Positive GZ	28.50 deg	15.00 deg
Gmt (upright damaged)	3.624 ft	
Righting Area (0.00-7.00)	13.245 ft-deg	2.820 ft-deg

DPR006A:
 180'ER W/LIFEBTS

Imaged Compartments:
 ENGINE ROOM

	DISPLACEMENT LTons	DRAFT AFT ft	DRAFT FWD ft	TRIM ft	HEEL deg.	UPRIGHT GMT ft
INTACT	794.1	8.238	6.780	1.458A	0.00	5.660
DAMAGED	962.5	9.708	7.411	2.297A	0.00	4.189

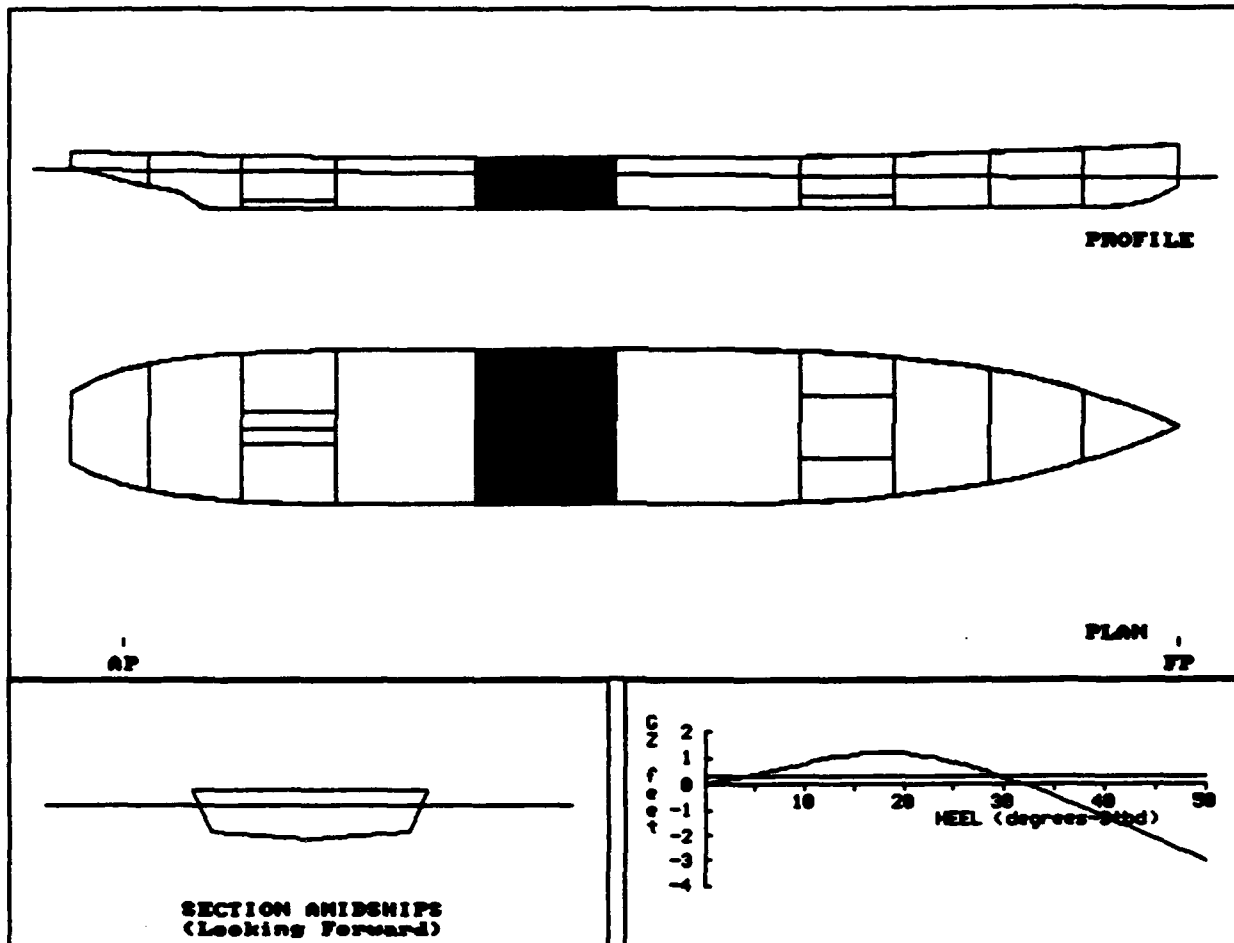

**DPRTO06A:
 180'ER W/LIFEBTS**

COMPARTMENT FLOODING SUMMARY

At 0.0o Heel	PERM.	FLOODED WTR LTons	% FULL (Damaged)	% FULL (Intact)	SP.VOL. ft3/LT	OUTFLOW LTons
ENGINE ROOM	0.85	168.4	FREE	0.0	----	----
Totals		168.4				

INTACT DATA

Draft at AP = 8.238 ft KMT = 22.640 ft LCG = 97.709A ft-FP
 Draft at FP = 6.780 ft VCG = 16.980 ft LCB = 97.810A ft-FP
 Displacement = 794.1 LTons GMT = 5.660 ft TCG = 0.000 ft-CL

DRAFT/GZ DATA

HEEL degrees	RIGHTING ARM ft	DRAFT AFT ft	DRAFT FWD ft	FLOODED WATER LTons
0.00	0.000	9.708	7.411	168.4
5.00S	0.373	9.664	7.391	168.0
7.00S	0.532	9.618	7.381	167.6
10.00S	0.791	9.530	7.340	166.7
20.00S	1.187	9.283	7.247	159.3
22.00S	1.093	9.283	7.247	157.5
30.00S	0.261	9.435	7.151	152.1
40.00S	-1.283	9.825	6.970	148.0
50.00S	-3.009	10.439	6.749	145.2

Note: Drafts are measured at A.P. and F.P along ship's centerline

GZ SUMMARY (Evaluated per IMO (SOLAS'90) Rules for Passenger Ships)

	Available	Required
Static Heel Angle	0.00 deg	7.00 deg
Angle at Maximum GZ	19.00S deg	
Maximum GZ	1.212 ft	0.328 ft
Range of Positive GZ	31.87 deg	15.00 deg
Gmt (upright damaged)	4.189 ft	
Righting Area (0.00-7.00)	16.938 ft-deg	2.820 ft-deg

DPR007A:
 180'ER W/LIFEBTS

Damaged Compartments:
 STORE ROOM

	DISPLACEMENT LTons	DRAFT AFT ft	DRAFT FWD ft	TRIM ft	HEEL deg.	UPRIGHT Gmt ft
INTACT	794.1	8.238	6.780	1.458A	0.00	5.660
DAMAGED	975.0	10.899	6.018	4.881A	0.00	4.310

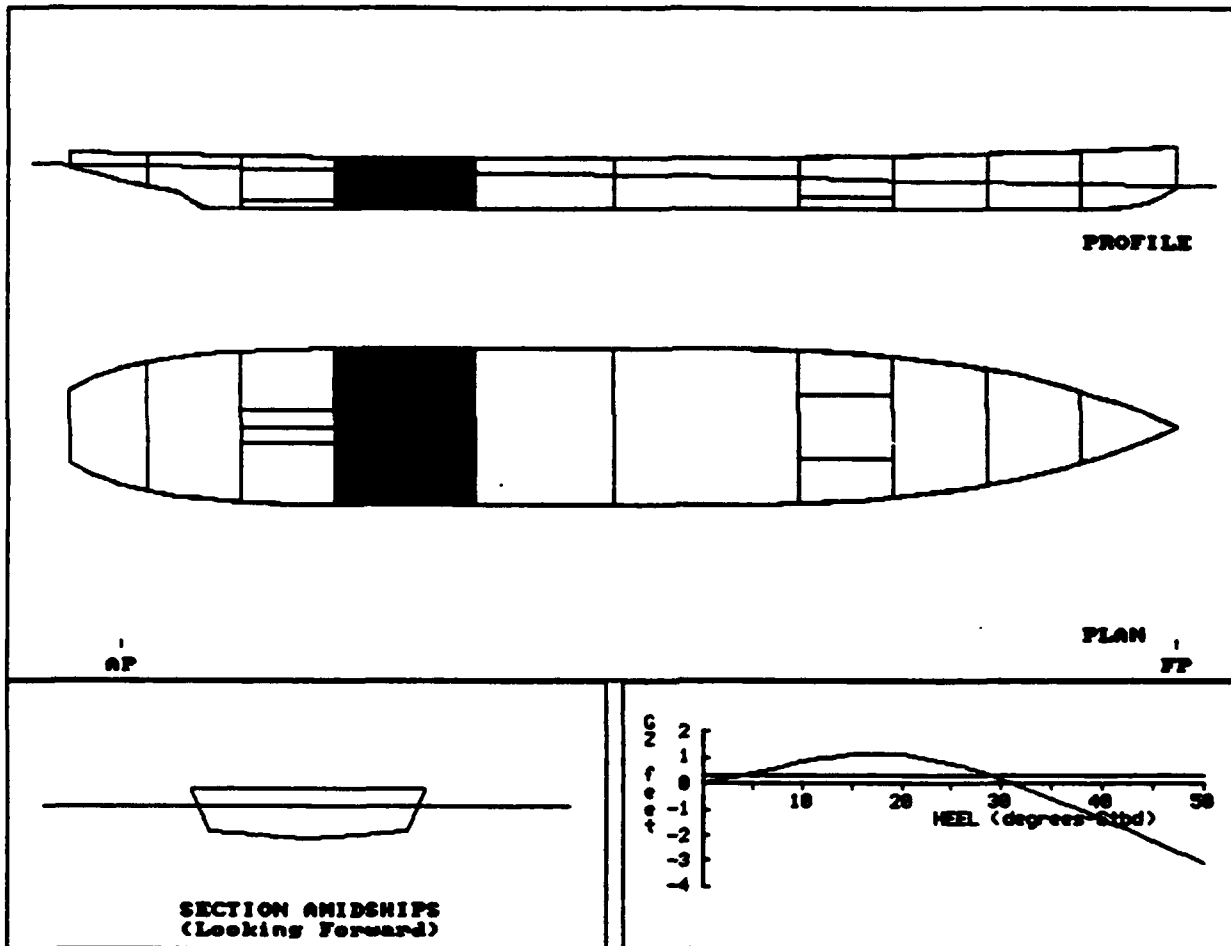

DPRT007A:
 180'ER W/LIFEBTS

COMPARTMENT FLOODING SUMMARY

At 0.0o Heel	PERM.	FLOODED WTR LTons	% FULL (Damaged)	% FULL (Intact)	SP.VOL. ft3/LT	OUTFLOW LTons
STORE ROOM	0.95	180.9	FREE	0.0	----	----
Totals		180.9				

INTACT DATA

Draft at AP = 8.238 ft KMt = 22.640 ft LCG = 97.709A ft-FP
 Draft at FP = 6.780 ft VCG = 16.980 ft LCB = 97.810A ft-FP
 Displacement = 794.1 LTons GMT = 5.660 ft TCG = 0.000 ft-CL

DRAFT/GZ DATA

HEEL degrees	RIGHTING ARM ft	DRAFT AFT ft	DRAFT FWD ft	FLOODED WATER LTons
0.00	0.000	10.899	6.018	180.9
5.00S	0.384	10.858	5.995	180.6
7.00S	0.549	10.802	5.994	180.2
10.00S	0.807	10.673	6.006	179.0
20.00S	1.110	10.737	5.732	171.7
22.00S	1.012	10.836	5.673	170.4
30.00S	0.172	11.471	5.245	167.1
40.00S	-1.368	12.567	4.565	164.2
50.00S	-3.090	14.133	3.672	162.2

Note: Drafts are measured at A.P. and F.P along ship's centerline

GZ SUMMARY (Evaluated per IMO (SOLAS'90) Rules for Passenger Ships)

	Available	Required
Static Heel Angle	0.00 deg	7.00 deg
Angle at Maximum GZ	19.00S deg	
Maximum GZ	1.148 ft	0.328 ft
Range of Positive GZ	31.24 deg	15.00 deg
Gmt (upright damaged)	4.310 ft	
Righting Area (0.00-%.00)	16.576 ft-deg	2.820 ft-deg

DPRTO08A:
 180'ER W/LIFEBTS

Imaged Compartments:
 VOID/FO TANK

	DISPLACEMENT LTons	DRAFT AFT ft	DRAFT FWD ft	TRIM ft	HEEL deg.	UPRIGHT GMT ft
INTACT	794.1	8.238	6.780	1.458A	0.00	5.660
DAMAGED	845.3	9.342	6.151	3.191A	0.00	4.356

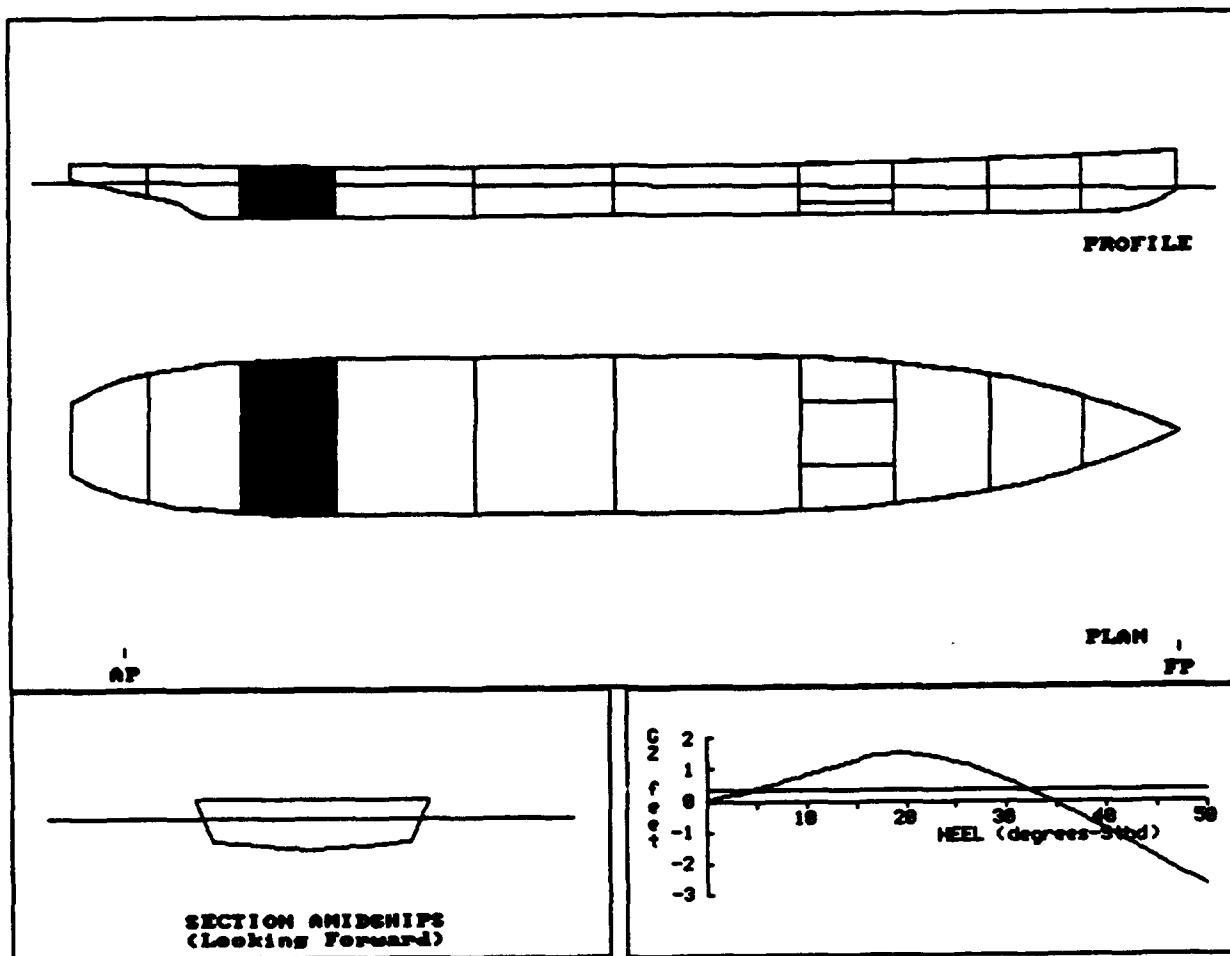

DPRT008A:
 180'ER W/LIFEBTS

COMPARTMENT FLOODING SUMMARY

At 0.0o Heel	PERM.	FLOODED WTR LTons	% FULL (Damaged)	% FULL (Intact)	SP.VOL. ft3/LT	OUTFLOW LTons
VOID/FO TANK	0.95	51.2	FREE	0.0	----	----
Totals		51.2				

INTACT DATA

Draft at AP = 8.238 ft	KMt = 22.640 ft	LCG = 97.709A ft-FP
Draft at FP = 6.780 ft	VCG = 16.980 ft	LCB = 97.810A ft-FP
Displacement = 794.1 LTons	GMT = 5.660 ft	TCG = 0.000 ft-CL

DRAFT/GZ DATA

HEEL degrees	RIGHTING ARM ft	DRAFT AFT ft	DRAFT FWD ft	FLOODED WATER LTons
0.00	0.000	9.342	6.151	51.2
5.00S	0.387	9.317	6.125	51.6
7.00S	0.552	9.282	6.112	51.9
10.00S	0.818	9.191	6.102	52.5
20.00S	1.510	8.899	5.903	54.8
22.00S	1.442	8.896	5.817	55.0
30.00S	0.648	8.894	5.478	55.4
40.00S	-0.921	9.054	4.884	55.3
50.00S	-2.717	9.335	4.117	54.9

Note: Drafts are measured at A.P. and F.P along ship's centerline

GZ SUMMARY (Evaluated per IMO (SOLAS '90) Rules for Passenger Ships)

	Available	Required
Static Heel Angle	0.00 deg	7.00 deg
Angle at Maximum GZ	21.00S deg	
Maximum GZ	1.510 ft	0.328 ft
Range of Positive GZ	34.44 deg	15.00 deg
Gmt (upright damaged)	4.356 ft	
Righting Area (0.00-3.00)	19.424 ft-deg	2.820 ft-deg

DPRT009A:
 180'ER W/LIFEBTS

Damaged Compartments:
 LAZARETTE

	DISPLACEMENT LTons	DRAFT AFT ft	DRAFT FWD ft	TRIM ft	HEEL deg.	UPRIGHT GMT ft
INTACT	794.1	8.238	6.780	1.458A	0.00	5.660
DAMAGED	828.3	9.130	6.166	2.964A	0.00	5.106

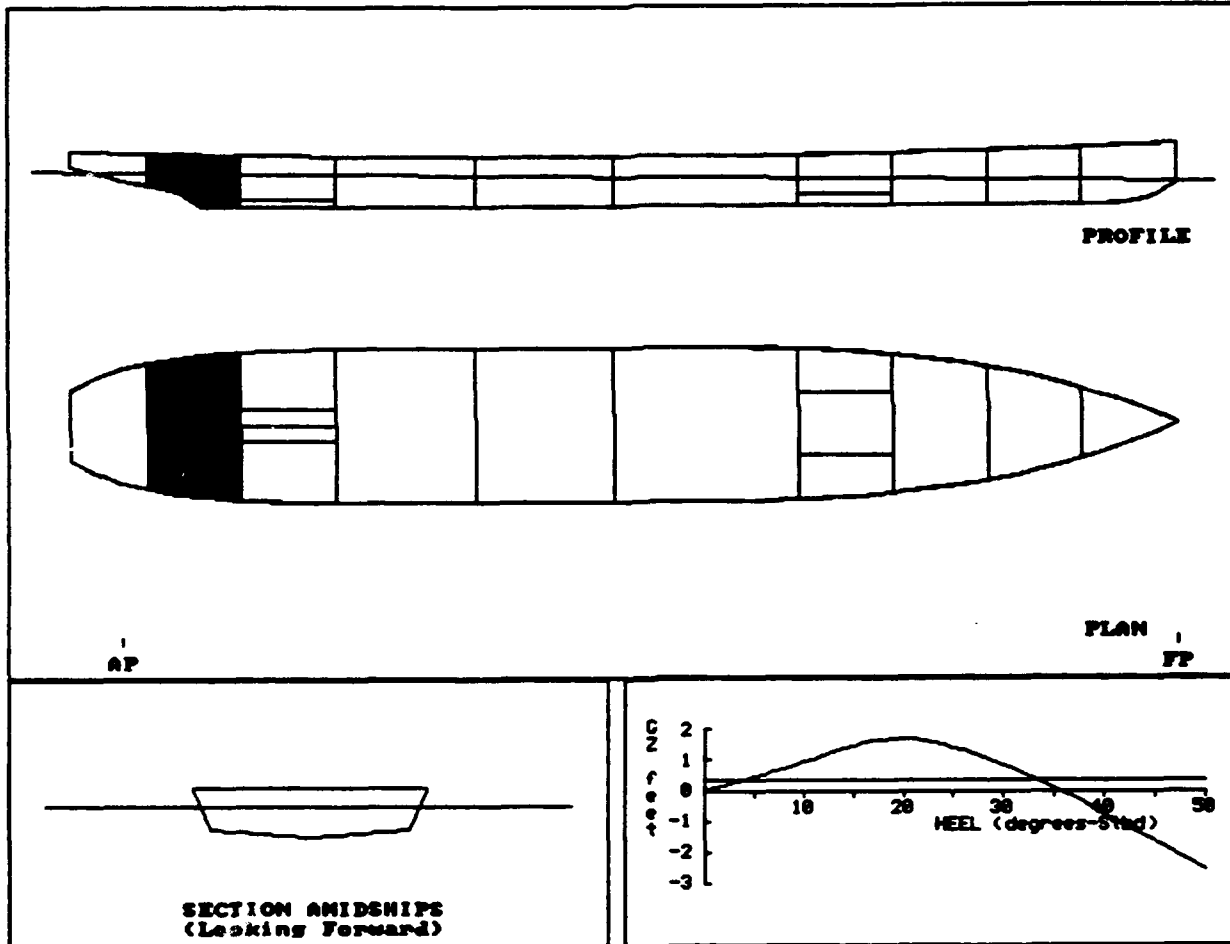

DPRT009A:
 180'ER W/LIFEBTS

COMPARTMENT FLOODING SUMMARY

At 0.0o Heel	PERM.	FLOODED WTR LTons	% FULL (Damaged)	% FULL (Intact)	SP.VOL. ft3/LT	OUTFLOW LTons
LAZARETTE	0.95	34.2	FREE	0.0	----	----
Totals		34.2				

INTACT DATA

Draft at AP	= 8.238 ft	KMT	= 22.640 ft	LCG	= 97.709A ft-FP
Draft at FP	= 6.780 ft	VCG	= 16.980 ft	LCB	= 97.810A ft-FP
Displacement	= 794.1 LTons	GMT	= 5.660 ft	TCG	= 0.000 ft-CL

DRAFT/GZ DATA

HEEL degrees	RIGHTING ARM ft	DRAFT AFT ft	DRAFT FWD ft	FLOODED WATER LTons
0.00	0.000	9.130	6.166	34.2
5.00S	0.452	9.110	6.135	34.6
7.00S	0.642	9.078	6.120	35.0
10.00S	0.946	8.996	6.101	35.8
20.00S	1.710	8.784	5.818	42.0
22.00S	1.641	8.810	5.702	43.3
30.00S	0.837	8.893	5.269	46.5
40.00S	-0.759	9.206	4.526	49.2
50.00S	-2.597	9.715	3.562	51.2

Note: Drafts are measured at A.P. and F.P along ship's centerline

GZ SUMMARY (Evaluated per IMO (SOLAS'90) Rules for Passenger Ships)
 Available Required

Static Heel Angle	0.00 deg	7.00 deg
Angle at Maximum GZ	21.00S deg	
Maximum GZ	1.710 ft	0.328 ft
Range of Positive GZ	35.56 deg	15.00 deg
Gmt (upright damaged)	5.106 ft	
Righting Area (0.00-7.00)	22.203 ft-deg	2.820 ft-deg

DPR010A:
 180'ER W/LIFEBTS

Damaged Compartments:
 AFTVOID

	DISPLACEMENT LTons	DRAFT AFT ft	DRAFT FWD ft	TRIM ft	HEEL deg.	UPRIGHT GMT ft
INTACT	794.1	8.238	6.780	1.458A	0.00	5.660
DAMAGED	795.3	8.271	6.757	1.515A	0.00	5.436

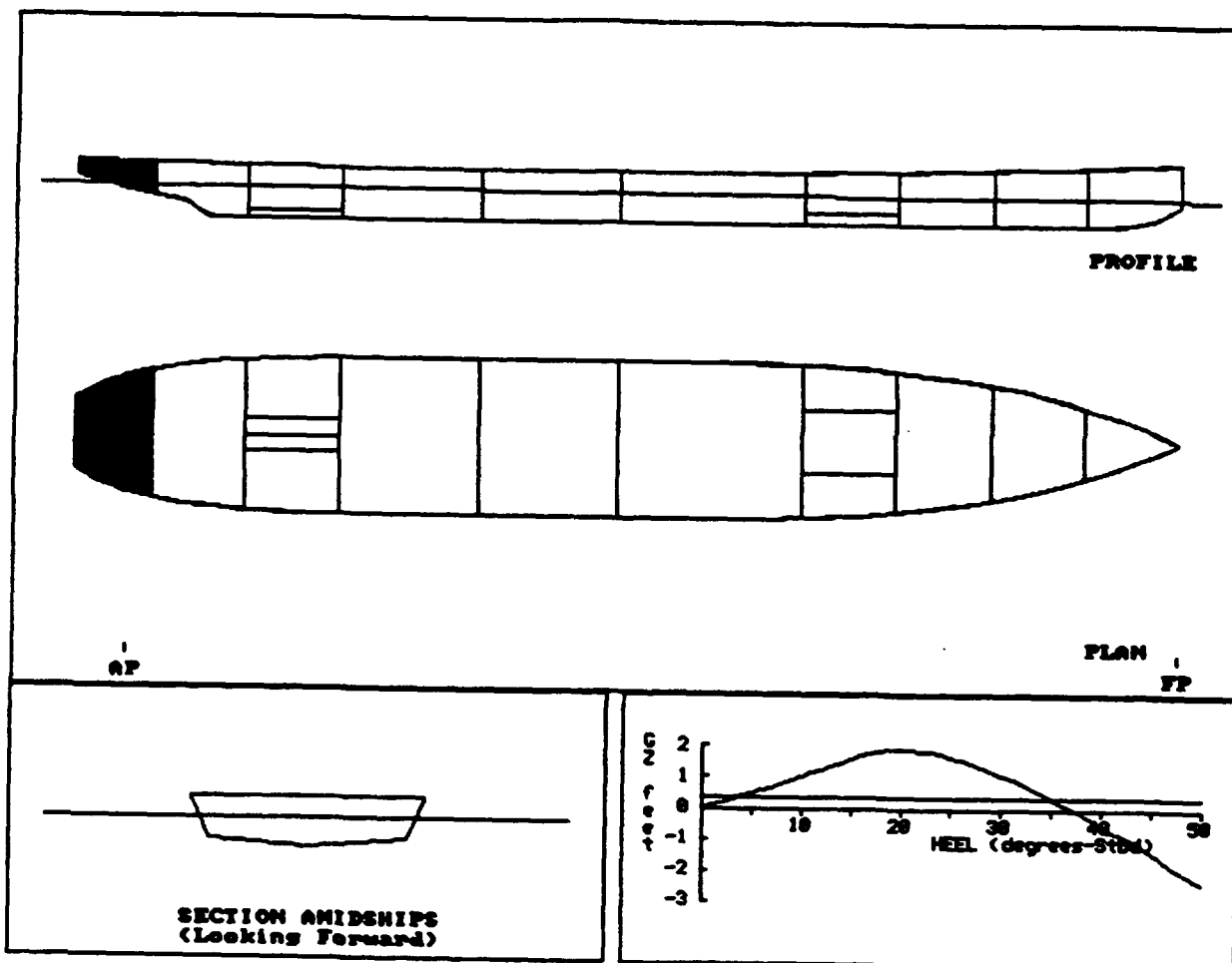

**DPRT010A:
 180'ER W/LIFEBTS**

COMPARTMENT FLOODING SUMMARY

At 0.0o Heel	PERM.	FLOODED WTR LTons	% FULL (Damaged)	% FULL (Intact)	SP.VOL. ft3/LT	OUTFLOW LTons
AFTVOID	0.95	1.2	FREE	0.0	----	----
Totals		1.2				

INTACT DATA

Draft at AP = 8.238 ft KMT = 22.640 ft LCG = 97.709A ft-FP
 Draft at FP = 6.780 ft VCG = 16.980 ft LCB = 97.810A ft-FP
 Displacement = 794.1 LTons GMT = 5.660 ft TCG = 0.000 ft-CL

DRAFT/GZ DATA

HEEL degrees	RIGHTING ARM ft	DRAFT AFT ft	DRAFT FWD ft	FLOODED WATER LTons
0.00	0.000	8.271	6.757	1.2
5.00S	0.481	8.246	6.728	1.2
7.00S	0.683	8.207	6.717	1.3
10.00S	1.002	8.130	6.681	1.3
20.00S	1.908	7.560	6.593	1.7
22.00S	1.861	7.462	6.544	2.1
30.00S	1.096	7.174	6.242	4.5
40.00S	-0.501	6.891	5.756	7.5
50.00S	-2.361	6.622	5.114	9.9

Note: Drafts are measured at A.P. and F.P along ship's centerline

GZ SUMMARY (Evaluated per IMO (SOLAS '90) Rules for Passenger Ships)

	Available	Required
Static Heel Angle	0.00 deg	7.00 deg
Angle at Maximum GZ	21.00S deg	
Maximum GZ	1.908 ft	0.328 ft
Range of Positive GZ	37.13 deg	15.00 deg
Gmt (upright damaged)	5.436 ft	
Righting Area (0.00-7.00)	24.135 ft-deg	2.820 ft-deg

**DEPT011A:
 180'ER W/LIFEBOATS**

Damaged Compartments:

VOID/FO TANK FO TANK STBD

	DISPLACEMENT LTons	DRAFT AFT ft	DRAFT FWD ft	TRIM ft	HEEL deg.	UPRIGHT GMT ft
INTACT	794.1	8.238	6.780	1.458A	0.00	5.660
DAMAGED	839.9	9.223	6.219	3.004A	0.16P	4.410

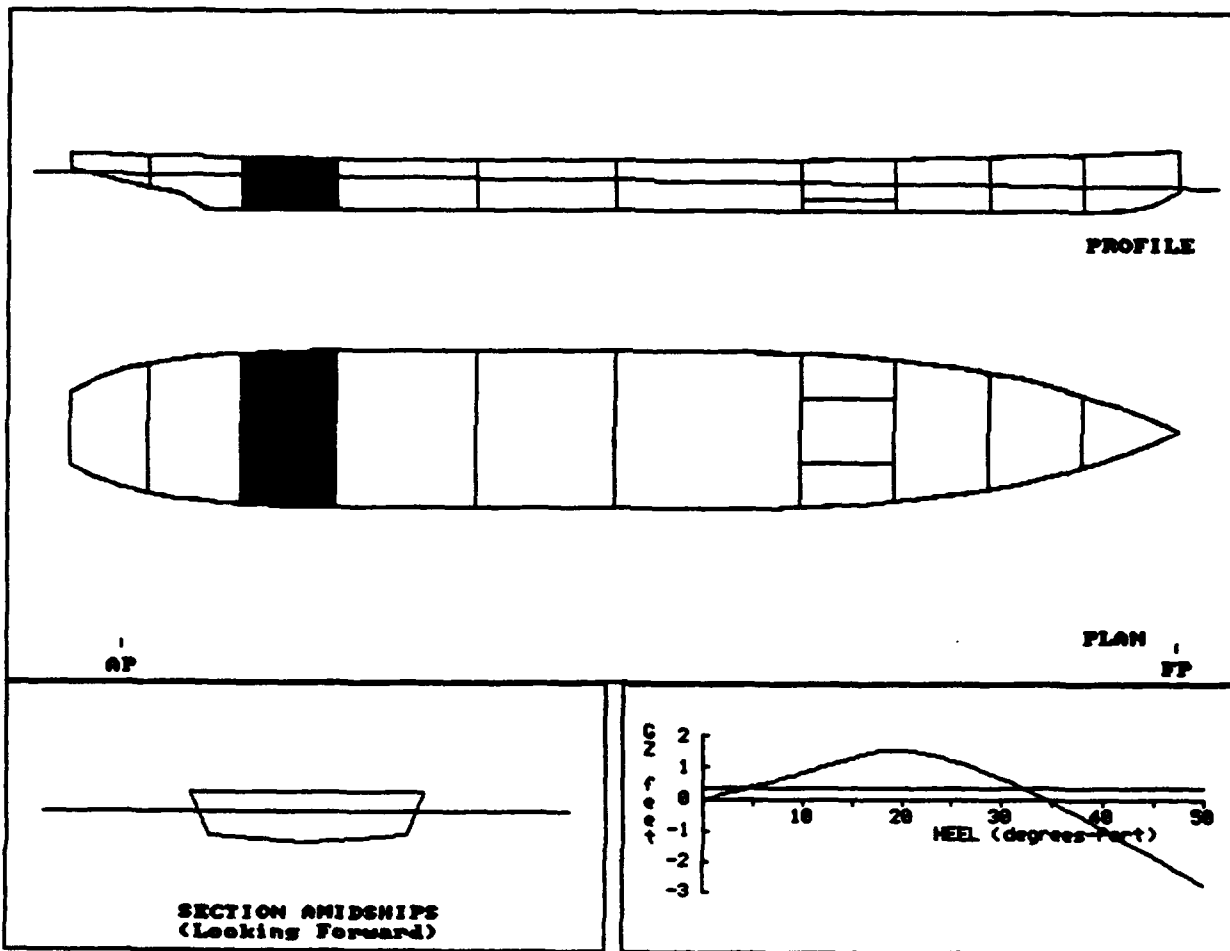

DPRT011A:
 180'ER W/LIFEBTS

COMPARTMENT FLOODING SUMMARY

At 0.20P Heel	PERM.	FLOODED WTR LTons	% FULL (Damaged)	% FULL (Intact)	SP.VOL. ft3/LT	OUTFLOW LTons
VOID/FO TANK	0.95	50.2	FREE	0.0	----	----
FO TANK STBD	0.95	11.9	FREE	95.0	40.8000	16.3
Totals		62.1				16.3

INTACT DATA

Draft at AP = 8.238 ft KMT = 22.640 ft LCG = 97.709A ft-FP
 Draft at FP = 6.780 ft VCG = 16.980 ft LCB = 97.810A ft-FP
 Displacement = 794.1 LTons GMT = 5.660 ft TCG = 0.000 ft-CL

DRAFT/GZ DATA

HEEL degrees	RIGHTING ARM ft	DRAFT AFT ft	DRAFT FWD ft	FLOODED WATER LTons
0.00	-0.012	9.224	6.220	62.1
5.00P	0.380	9.196	6.194	62.1
7.00P	0.546	9.156	6.184	62.2
10.00P	0.813	9.050	6.182	62.2
20.00P	1.525	8.697	6.009	63.4
22.00P	1.458	8.680	5.927	63.5
30.00P	0.652	8.590	5.620	63.1
40.00P	-0.946	8.593	5.089	62.1
50.00P	-2.780	8.635	4.413	60.6

Note: Drafts are measured at A.P. and F.P along ship's centerline

GZ SUMMARY (Evaluated per IMO (SOLAS'90) Rules for Passenger Ships)

	Available	Required
Static Heel Angle	0.16P deg	7.00 deg
Angle at Maximum GZ	21.00P deg	
Maximum GZ	1.525 ft	0.328 ft
Range of Positive GZ	34.24 deg	15.00 deg
Righting Area (0.16-4.00)	19.421 ft-deg	2.820 ft-deg

RTRN001A:
 180'ER W/LIFEBTS

Imaged Compartments:
 FOREPEAK

	DISPLACEMENT LTons	DRAFT AFT ft	DRAFT FWD ft	TRIM ft	HEEL deg.	UPRIGHT GMT ft
INTACT	738.6	8.146	6.057	2.089A	0.00	5.756
DAMAGED	744.4	8.014	6.311	1.703A	0.00	5.543

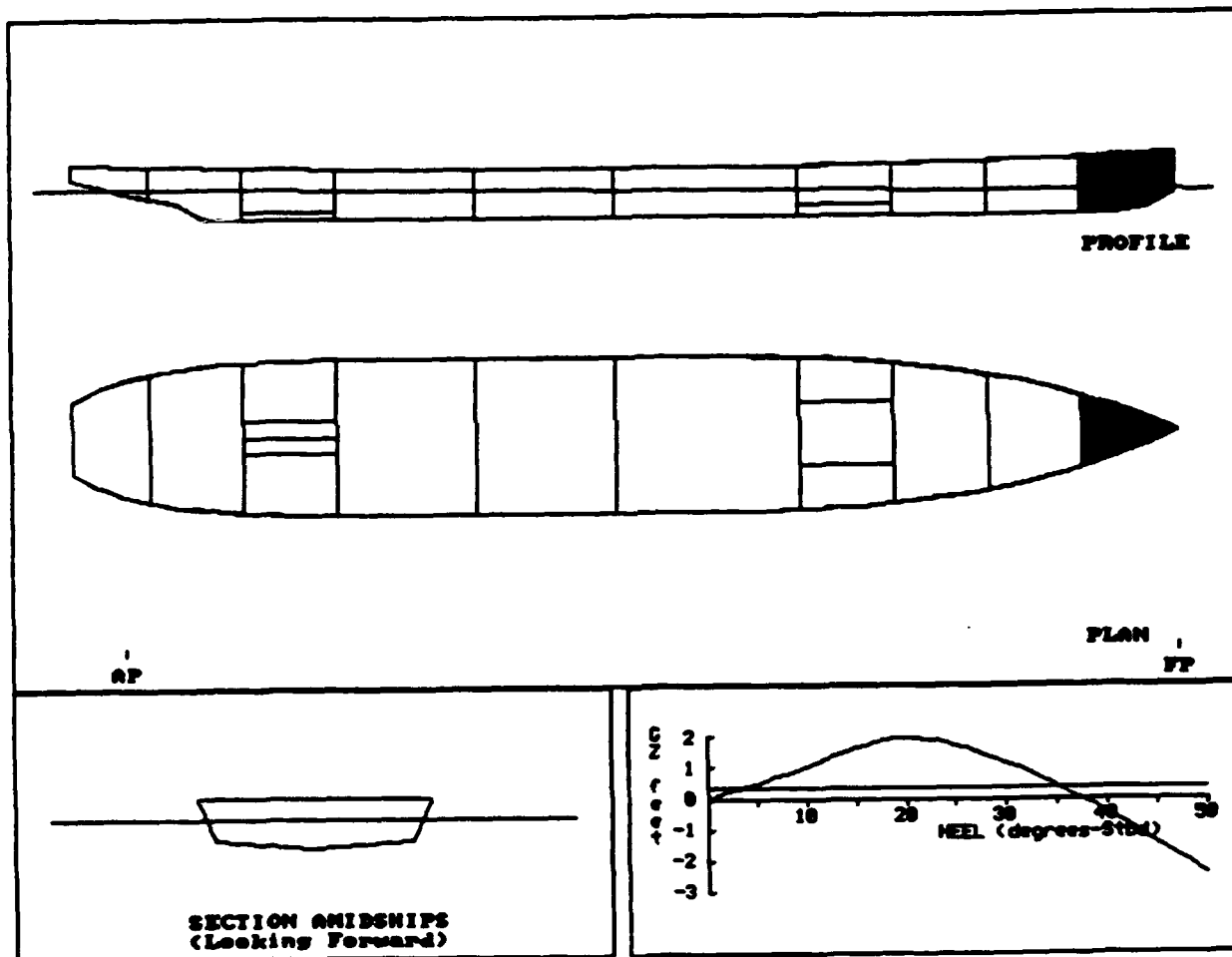

RTRN002A:
 180'ER W/LIFEBTS

Imaged Compartments:
 VOID1

	DISPLACEMENT LTons	DRAFT AFT ft	DRAFT FWD ft	TRIM ft	HEEL deg.	UPRIGHT GMT ft
INTACT	738.6	8.146	6.057	2.089A	0.00	5.756
DAMAGED	762.7	7.745	6.915	0.830A	0.00	5.534

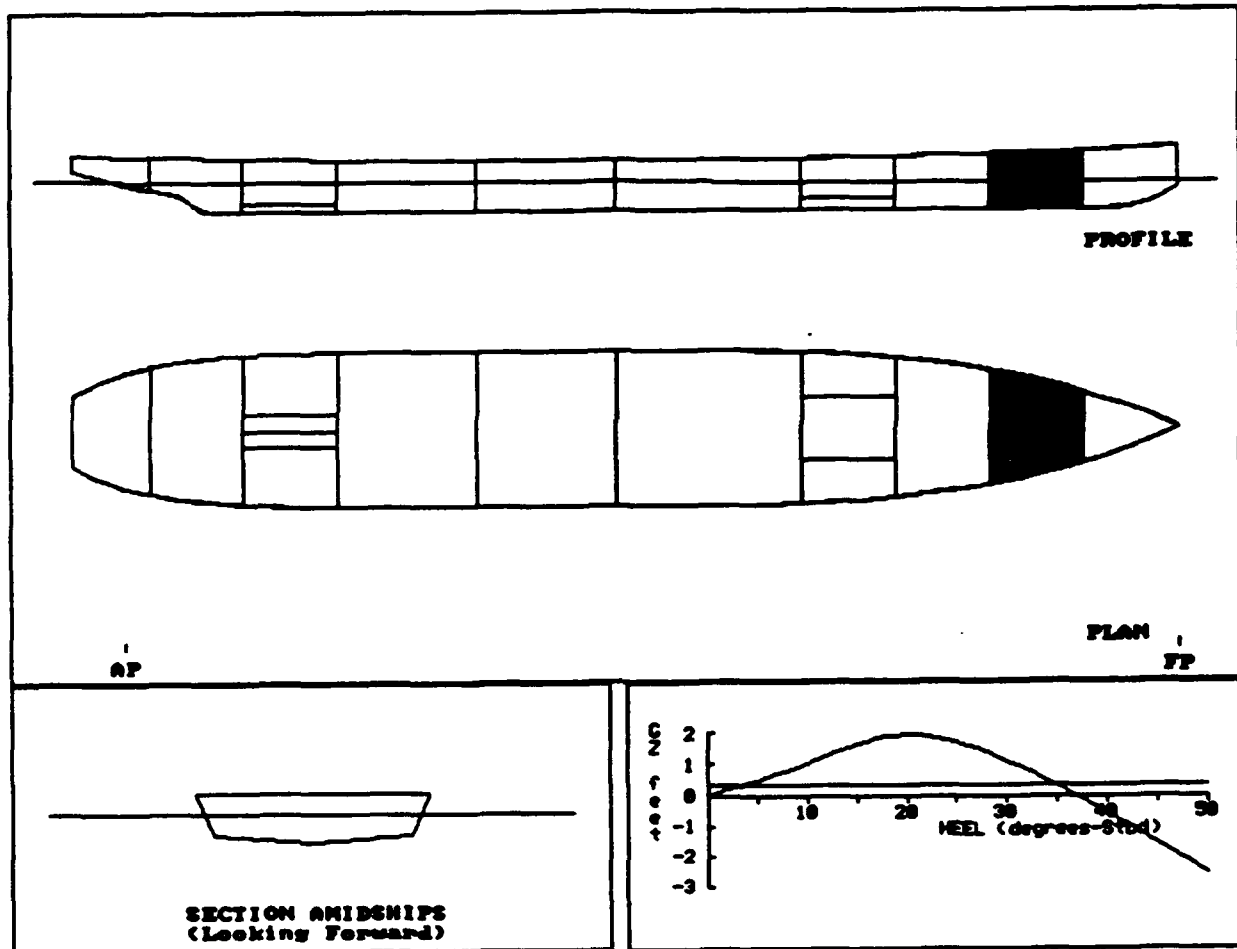

RTRN003A:
 180'ER W/LIFEBTS

Imaged Compartments:
 VO102

	DISPLACEMENT LTons	DRAFT AFT ft	DRAFT FWD ft	TRIM ft	HEEL deg.	UPRIGHT GMT ft
INTACT	738.6	8.146	6.057	2.089A	0.00	5.756
DAMAGED	789.3	7.559	7.537	0.022A	0.00	5.193

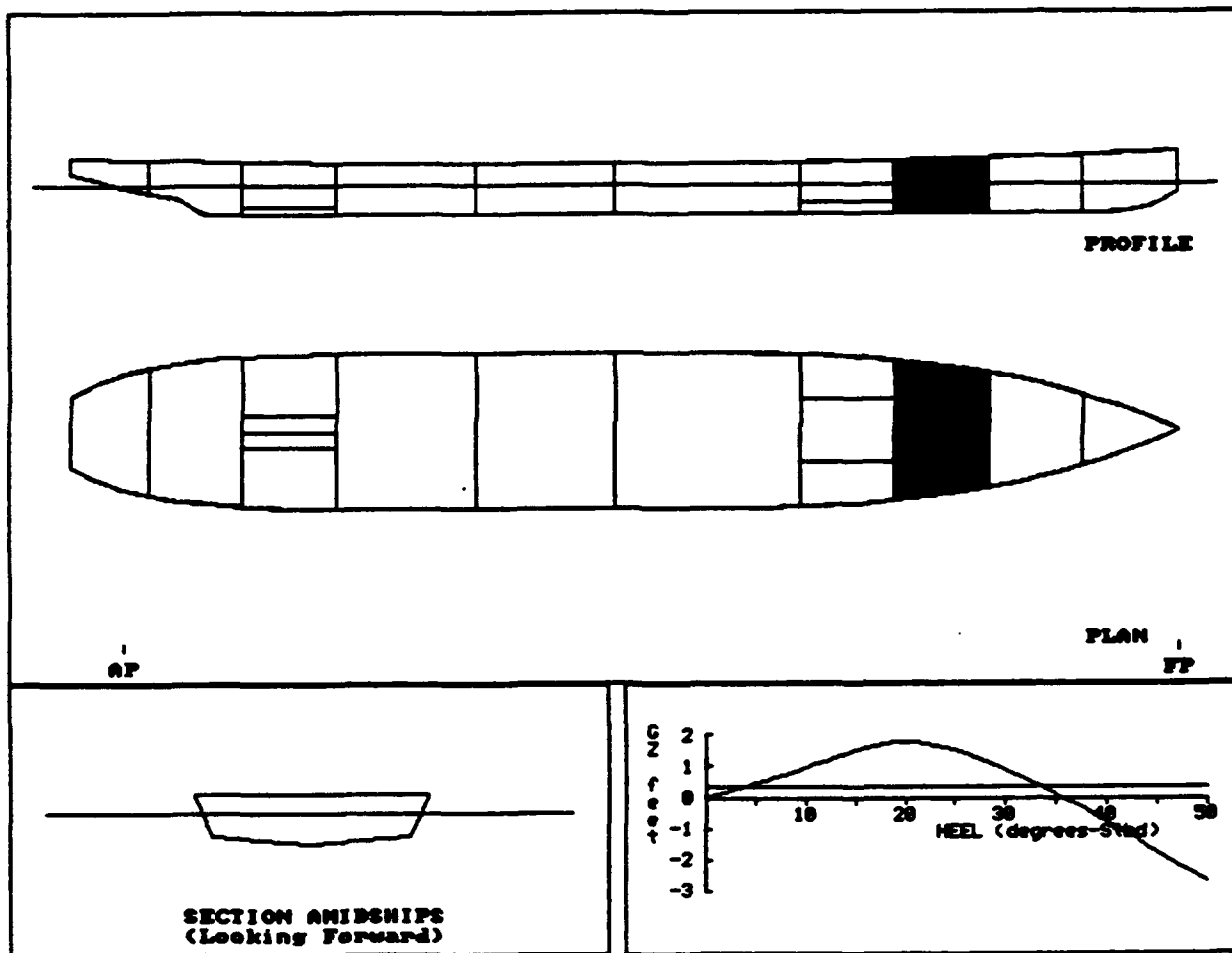

RTRM003A:
 180'ER W/LIFEBTS

COMPARTMENT FLOODING SUMMARY

At 0.0o Heel	PERM.	FLOODED WTR LTons	% FULL (Damaged)	% FULL (Intact)	SP.VOL. ft3/LT	OUTFLOW LTons
VOID2	0.95	50.7	FREE	0.0	----	----
Totals		50.7				

INTACT DATA

Draft at AP = 8.146 ft	KMT = 23.326 ft	LCG = 98.786A ft-FP
Draft at FP = 6.057 ft	VCG = 17.570 ft	LCB = 98.940A ft-FP
Displacement = 738.6 LTons	GMT = 5.756 ft	TCG = 0.000 ft-CL

DRAFT/GZ DATA

HEEL degrees	RIGHTING ARM ft	DRAFT AFT ft	DRAFT FWD ft	FLOODED WATER LTons
0.00	0.000	7.559	7.537	50.7
5.00S	0.459	7.522	7.523	50.9
7.00S	0.650	7.479	7.519	51.1
10.00S	0.951	7.390	7.501	51.5
20.00S	1.781	6.691	7.590	56.1
22.00S	1.718	6.532	7.614	57.4
30.00S	0.890	5.842	7.758	61.1
40.00S	-0.786	4.941	7.880	63.0
50.00S	-2.718	3.815	8.020	63.7

Note: Drafts are measured at A.P. and F.P along ship's centerline

GZ SUMMARY (Evaluated per IMO (SOLAS'90) Rules for Passenger Ships)
 Available Required

Static Heel Angle	0.00 deg	7.00 deg
Angle at Maximum GZ	21.00S deg	
Maximum GZ	1.781 ft	0.328 ft
Range of Positive GZ	35.63 deg	15.00 deg
Gmt (upright damaged)	5.193 ft	
Righting Area (0.00-3.00)	22.752 ft-deg	2.820 ft-deg

RTRN004A:
 180'ER W/LIFEBOATS

Damaged Compartments:
 FW TANK STD

	DISPLACEMENT LTons	DRAFT AFT ft	DRAFT FWD ft	TRIM ft	HEEL deg.	UPRIGHT Gmt ft
INTACT	738.6	8.146	6.057	2.089A	0.00	5.756
DAMAGED	746.8	8.072	6.262	1.810A	1.35S	4.900

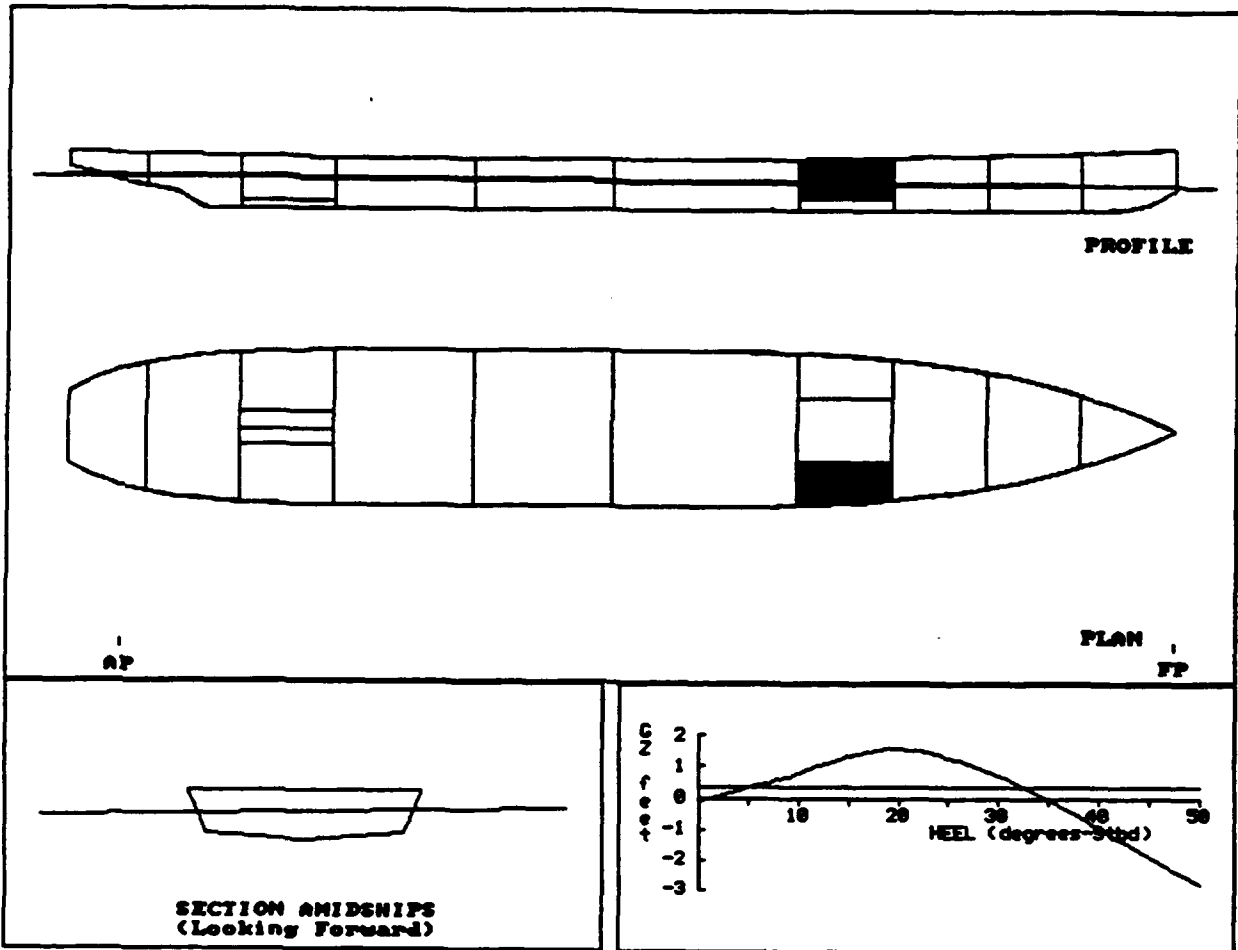

RTRN004A:
 180'ER W/LIFEBTS

COMPARTMENT FLOODING SUMMARY

At 1.3oS Heel	PERM.	FLOODED WTR LTons	% FULL (Damaged)	% FULL (Intact)	SP.VOL. ft3/LT	OUTFLOW LTons
FW TANK STBD	0.95	11.9	FREE	10.0	35.8800	3.7
Totals		11.9				3.7

INTACT DATA

Draft at AP = 8.146 ft	KMT = 23.326 ft	LCG = 98.786A ft-FP
Draft at FP = 6.057 ft	VCG = 17.570 ft	LCB = 98.940A ft-FP
Displacement = 738.6 LTons	GMT = 5.756 ft	TCG = 0.000 ft-CL

DRAFT/GZ DATA

HEEL degrees	RIGHTING ARM ft	DRAFT AFT ft	DRAFT FWD ft	FLOODED WATER LTons
0.00	-0.115	8.082	6.248	10.9
5.00S	0.316	8.034	6.305	14.8
7.00S	0.497	7.986	6.330	16.5
10.00S	0.782	7.887	6.362	19.2
20.00S	1.572	7.177	6.517	29.7
22.00S	1.510	7.022	6.519	31.5
30.00S	0.710	6.439	6.416	35.7
40.00S	-0.934	5.703	6.152	37.5
50.00S	-2.837	4.798	5.750	37.6

Note: Drafts are measured at A.P. and F.P along ship's centerline

GZ SUMMARY (Evaluated per IMO (SOLAS '90) Rules for Passenger Ships)

	Available	Required
Static Heel Angle	1.35S deg	7.00 deg
Angle at Maximum GZ	21.00S deg	
Maximum GZ	1.572 ft	0.328 ft
Range of Positive GZ	33.32 deg	15.00 deg
Righting Area (1.35-7.00)	19.058 ft-deg	2.820 ft-deg

RTRN005A:
 180'ER W/LIFEBTS

Imaged Compartments:
 CREW

	DISPLACEMENT LTons	DRAFT AFT ft	DRAFT FWD ft	TRIM ft	HEEL deg.	UPRIGHT GMT ft
INTACT	738.6	8.146	6.057	2.089A	0.00	5.756
DAMAGED	990.3	8.421	9.400	0.979F	0.00	3.324

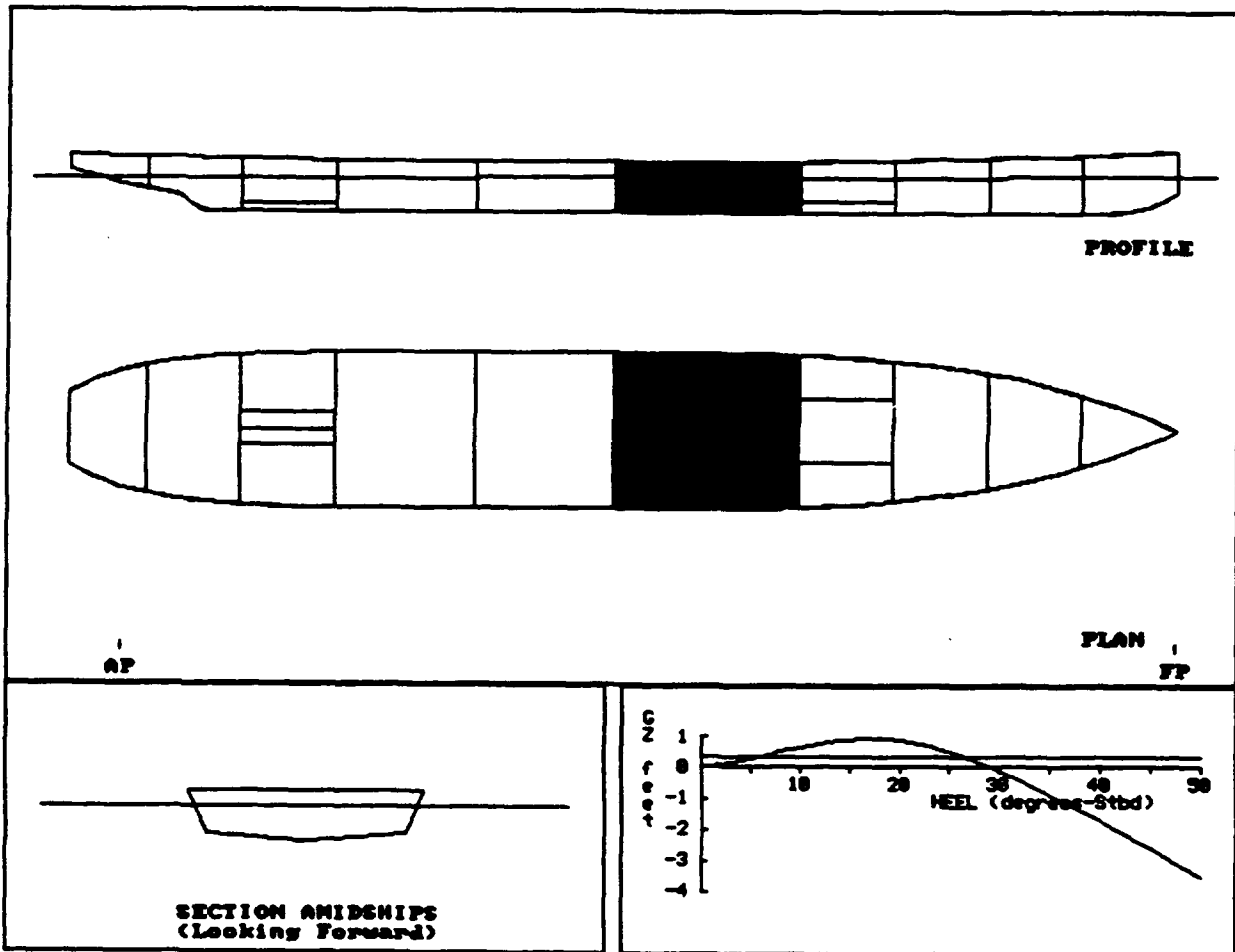

RTRN005A:
 180'ER W/LIFEBTS

COMPARTMENT FLOODING SUMMARY

At 0.0o Heel	PERM.	FLOODED WTR LTons	% FULL (Damaged)	% FULL (Intact)	SP.VOL. ft3/LT	OUTFLOW LTons
CREW	0.95	251.7	FREE	0.0	----	----
Totals		251.7				

INTACT DATA

Draft at AP = 8.146 ft	KMT = 23.326 ft	LCG = 98.786A ft-FP
Draft at FP = 6.057 ft	VCG = 17.570 ft	LCB = 98.940A ft-FP
Displacement = 738.6 LTons	GMT = 5.756 ft	TCG = 0.000 ft-CL

DRAFT/GZ DATA

HEEL degrees	RIGHTING ARM ft	DRAFT AFT ft	DRAFT FWD ft	FLOODED WATER LTons
0.00	0.000	8.421	9.400	251.7
5.00S	0.297	8.379	9.377	251.2
7.00S	0.424	8.340	9.358	250.9
10.00S	0.634	8.259	9.311	250.1
20.00S	0.897	7.887	9.309	239.8
22.00S	0.778	7.838	9.351	236.7
30.00S	-0.123	7.672	9.601	227.2
40.00S	-1.726	7.492	10.030	219.6
50.00S	-3.499	7.337	10.646	214.6

Note: Drafts are measured at A.P. and F.P along ship's centerline

GZ SUMMARY (Evaluated per IMO (SOLAS'90) Rules for Passenger Ships)

	Available	Required
Static Heel Angle	0.00 deg	7.00 deg
Angle at Maximum GZ	19.00S deg	
Maximum GZ	0.946 ft	0.328 ft
Range of Positive GZ	29.11 deg	15.00 deg
Gmt (upright damaged)	3.324 ft	
Righting Area (0.00-7.00)	13.296 ft-deg	2.820 ft-deg

RTRN006A:
 180'ER W/LIFEBTS

Imaged Compartments:
 ENGINE ROOM

	DISPLACEMENT LTons	DRAFT AFT ft	DRAFT FWD ft	TRIM ft	HEEL deg.	UPRIGHT Gmt ft
INTACT	738.6	8.146	6.057	2.089A	0.00	5.756
DAMAGED	898.3	9.550	6.676	2.873A	0.00	4.027

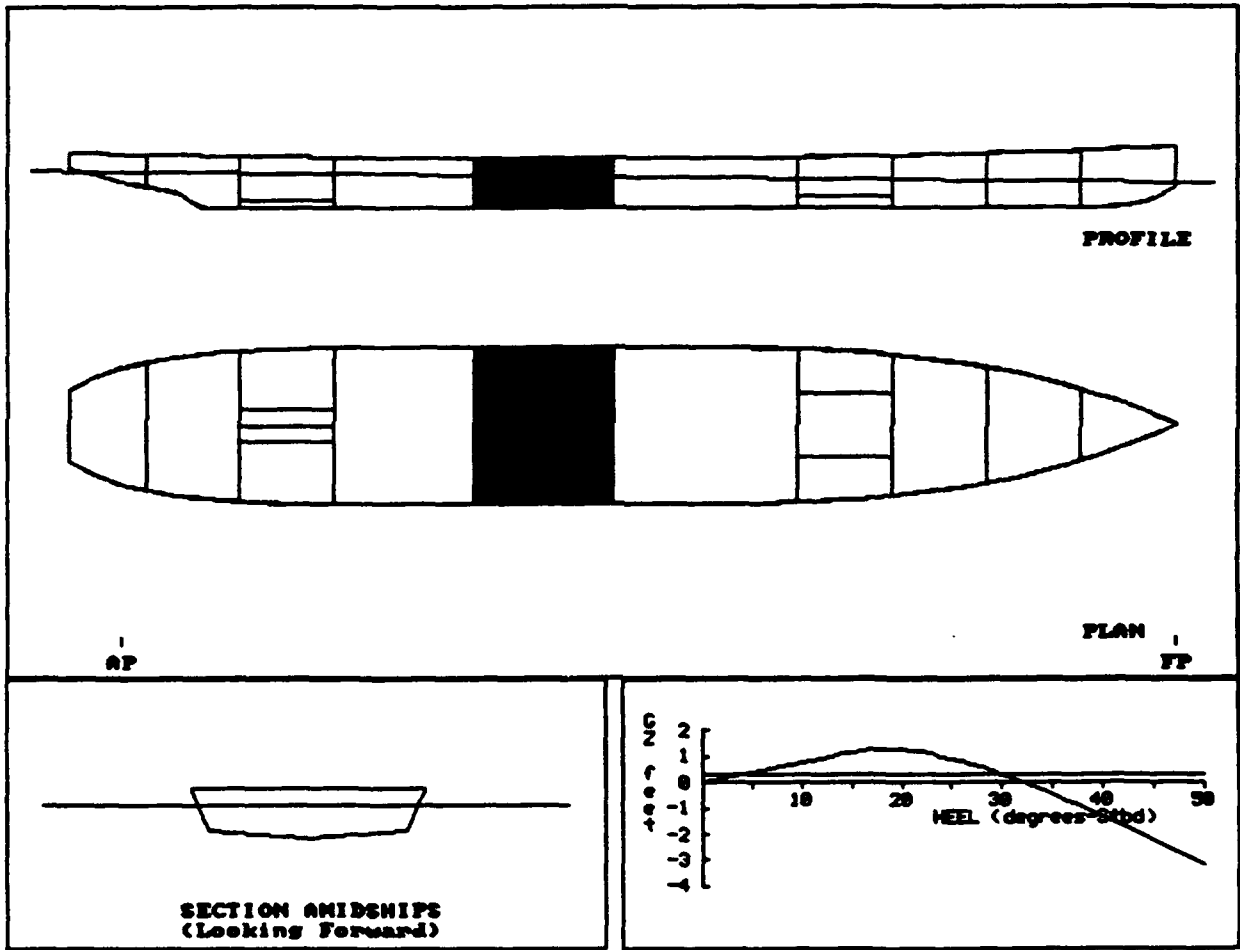

RTRN006A:
 180'ER W/LIFEBTS

COMPARTMENT FLOODING SUMMARY

At 0.0o Heel	PERM.	FLOODED WTR LTons	% FULL (Damaged)	% FULL (Intact)	SP.VOL. ft3/LT	OUTFLOW LTons
ENGINE ROOM	0.85	159.7	FREE	0.0	----	----
Totals		159.7				

INTACT DATA

Draft at AP = 8.146 ft	KMt = 23.326 ft	LCG = 98.786A ft-FP
Draft at FP = 6.057 ft	VCG = 17.570 ft	LCB = 98.940A ft-FP
Displacement = 738.6 LTons	GMT = 5.756 ft	TCG = 0.000 ft-CL

DRAFT/GZ DATA

HEEL degrees	RIGHTING ARM ft	DRAFT AFT ft	DRAFT FWD ft	FLOODED WATER LTons
0.00	0.000	9.550	6.676	159.7
5.00S	0.359	9.506	6.657	159.2
7.00S	0.513	9.461	6.645	158.8
10.00S	0.763	9.349	6.637	157.9
20.00S	1.271	9.013	6.471	151.1
22.00S	1.175	9.001	6.413	149.4
30.00S	0.306	8.989	6.159	144.4
40.00S	-1.324	9.133	5.730	140.4
50.00S	-3.158	9.430	5.163	137.8

Note: Drafts are measured at A.P. and F.P along ship's centerline

GZ SUMMARY (Evaluated per IMO (SOLAS'90) Rules for Passenger Ships)

	Available	Required
Static Heel Angle	0.00 deg	7.00 deg
Angle at Maximum GZ	20.00S deg	
Maximum GZ	1.288 ft	0.328 ft
Range of Positive GZ	32.08 deg	15.00 deg
Gmt (upright damaged)	4.027 ft	
Righting Area (0.00-7.00)	17.242 ft-deg	2.820 ft-deg

RTRN007A:
 180'ER W/LIFEBTS

Imaged Compartments:
 STORE ROOM

	DISPLACEMENT LTons	DRAFT AFT ft	DRAFT FWD ft	TRIM ft	HEEL deg.	UPRIGHT Gmt ft
INTACT	738.6	8.146	6.057	2.089A	0.00	5.756
DAMAGED	911.7	10.732	5.298	5.434A	0.00	4.185

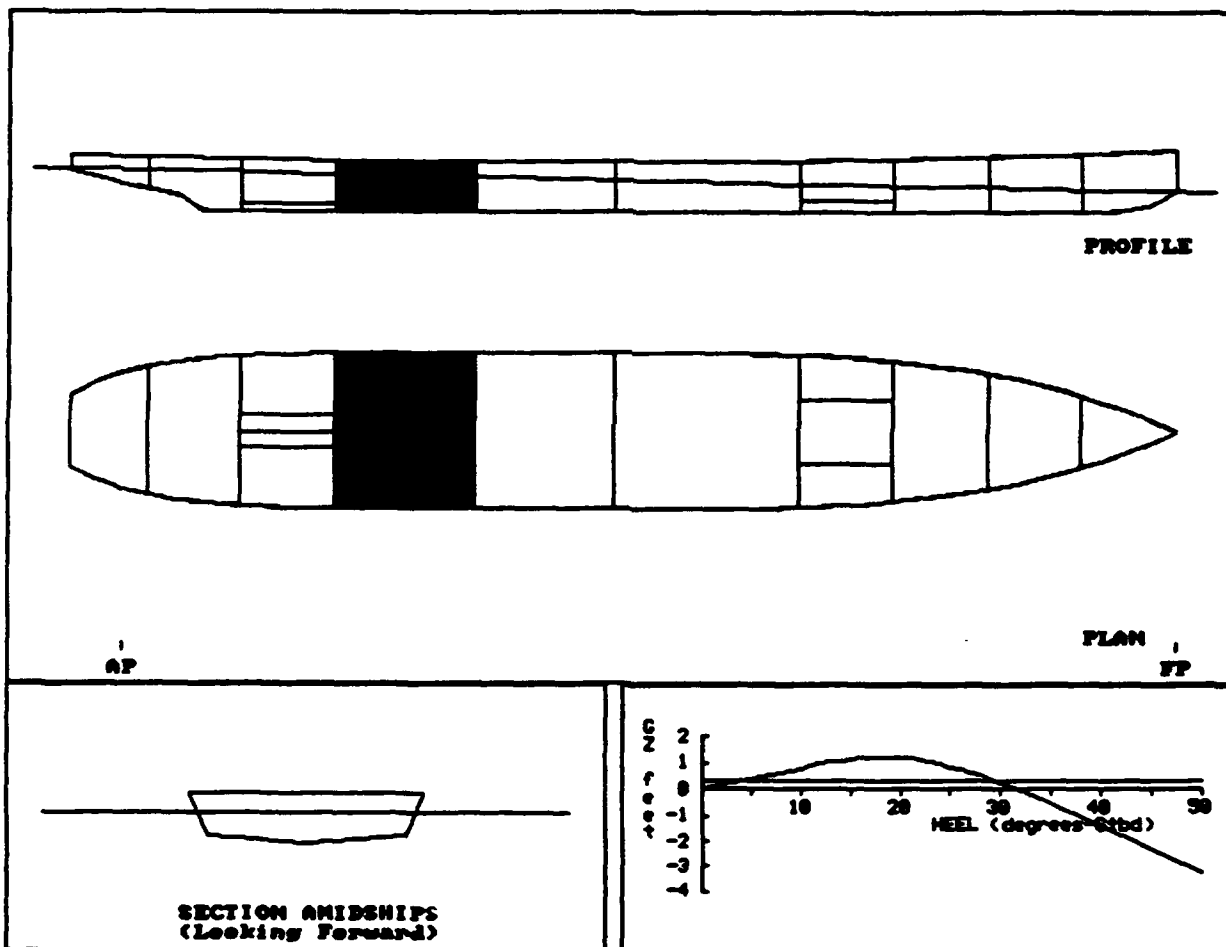

RTRN007A:
 180'ER W/LIFEBTS

COMPARTMENT FLOODING SUMMARY

At 0.0o Heel	PERM.	FLOODED WTR LTons	% FULL (Damaged)	% FULL (Intact)	SP.VOL. ft3/LT	OUTFLOW LTons
STORE ROOM	0.95	173.1	FREE	0.0	----	----
Totals		173.1				

INTACT DATA

Draft at AP = 8.146 ft	KMt = 23.326 ft	LCG = 98.786A ft-FP
Draft at FP = 6.057 ft	VCG = 17.570 ft	LCB = 98.940A ft-FP
Displacement = 738.6 LTons	GMT = 5.756 ft	TCG = 0.000 ft-CL

DRAFT/GZ DATA

HEEL degrees	RIGHTING ARM ft	DRAFT AFT ft	DRAFT FWD ft	FLOODED WATER LTons
0.00	0.000	10.732	5.298	173.1
5.00S	0.374	10.693	5.275	172.8
7.00S	0.534	10.638	5.273	172.4
10.00S	0.792	10.505	5.290	171.3
20.00S	1.214	10.427	4.993	164.4
22.00S	1.116	10.502	4.881	163.2
30.00S	0.231	10.933	4.332	159.6
40.00S	-1.394	11.729	3.430	156.5
50.00S	-3.225	12.911	2.223	154.3

Note: Drafts are measured at A.P. and F.P along ship's centerline

GZ SUMMARY (Evaluated per IMO (SOLAS'90) Rules for Passenger Ships)

	Available	Required
Static Heel Angle	0.00 deg	7.00 deg
Angle at Maximum GZ	19.00S deg	
Maximum GZ	1.237 ft	0.328 ft
Range of Positive GZ	31.57 deg	15.00 deg
Gmt (upright damaged)	4.185 ft	
Righting Area (0.00-7.00)	17.144 ft-deg	2.820 ft-deg

RTRN008A:
 180'ER W/LIFEBTS

Imaged Compartments:
 VOID/FO TANK

	DISPLACEMENT LTons	DRAFT AFT ft	DRAFT FWD ft	TRIN ft	HEEL deg.	UPRIGHT Gmt ft
INTACT	738.6	8.146	6.057	2.089A	0.00	5.756
DAMAGED	787.3	9.211	5.441	3.770A	0.00	4.359

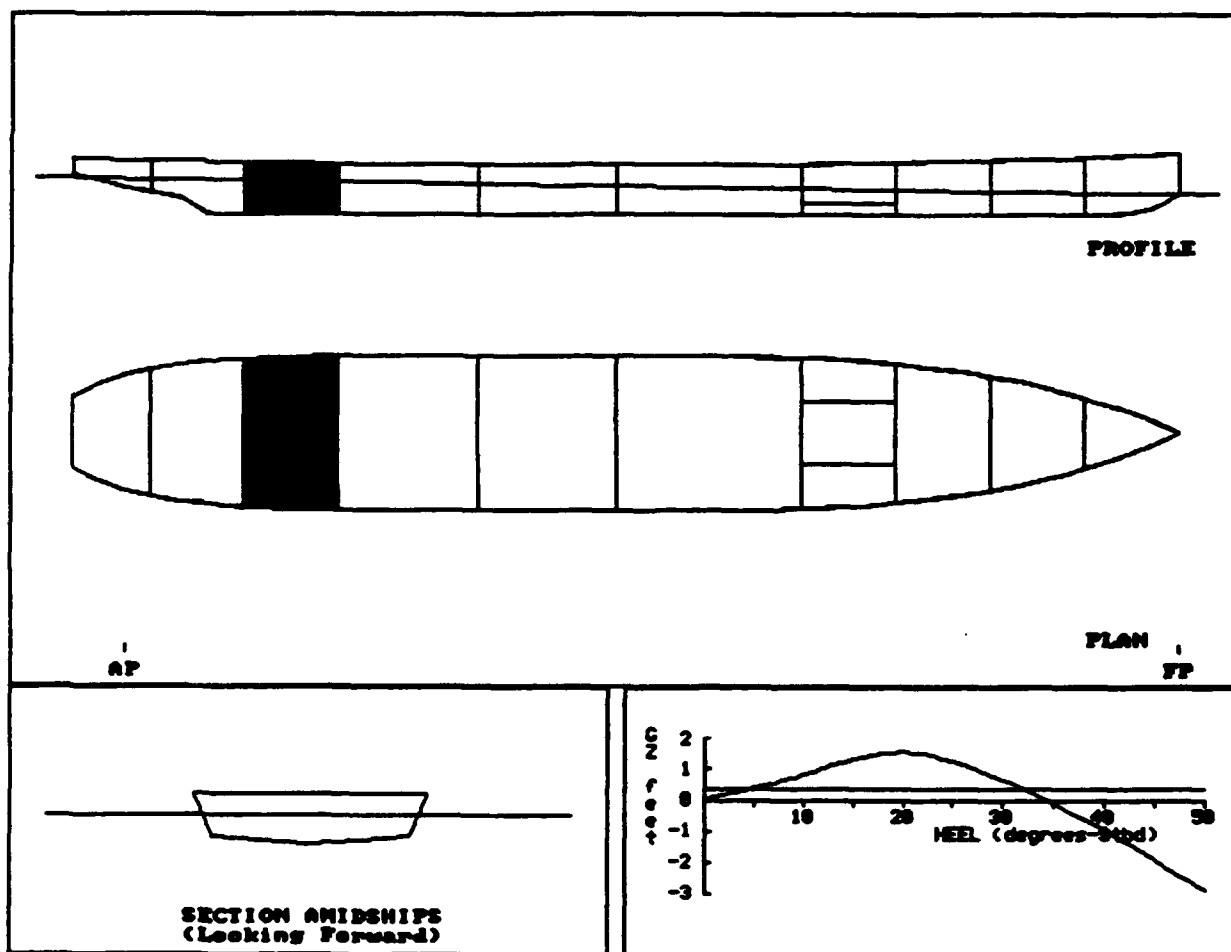

RTRN008A:
 180'ER W/LIFEBTS

COMPARTMENT FLOODING SUMMARY

At 0.0o Heel	PERM.	FLOODED WTR LTons	% FULL (Damaged)	% FULL (Intact)	SP.VOL. ft3/LT	OUTFLOW LTons
VOID/FO TANK	0.95	48.7	FREE	0.0	----	----
Totals		48.7				

INTACT DATA

Draft at AP = 8.146 ft	KMT = 23.326 ft	LCG = 98.786A ft-FP
Draft at FP = 6.057 ft	VCG = 17.570 ft	LCB = 98.940A ft-FP
Displacement = 738.6 LTons	GMT = 5.756 ft	TCG = 0.000 ft-CL

DRAFT/GZ DATA

HEEL degrees	RIGHTING ARM ft	DRAFT AFT ft	DRAFT FWD ft	FLOODED WATER LTons
0.00	0.000	9.211	5.441	48.7
5.00S	0.388	9.192	5.410	49.1
7.00S	0.553	9.158	5.397	49.4
10.00S	0.819	9.060	5.393	49.9
20.00S	1.557	8.687	5.155	52.7
22.00S	1.493	8.638	5.053	53.0
30.00S	0.663	8.530	4.544	53.7
40.00S	-0.981	8.523	3.683	54.2
50.00S	-2.877	8.595	2.561	54.5

Note: Drafts are measured at A.P. and F.P along ship's centerline

GZ SUMMARY (Evaluated per IMO (SOLAS'90) Rules for Passenger Ships)

	Available	Required
Static Heel Angle	0.00 deg	7.00 deg
Angle at Maximum GZ	21.00S deg	
Maximum GZ	1.557 ft	0.328 ft
Range of Positive GZ	34.34 deg	15.00 deg
Gmt (upright damaged)	4.359 ft	
Righting Area (0.00-7.00)	19.743 ft-deg	2.820 ft-deg

RTRN009A:
 180'ER W/LIFEBTS

Imaged Compartments:
 LAZARETTE

	DISPLACEMENT LTons	DRAFT AFT ft	DRAFT FWD ft	TRIM ft	HEEL deg.	UPRIGHT GMT ft
INTACT	738.6	8.146	6.057	2.089A	0.00	5.756
DAMAGED	771.0	9.007	5.455	3.552A	0.00	5.168

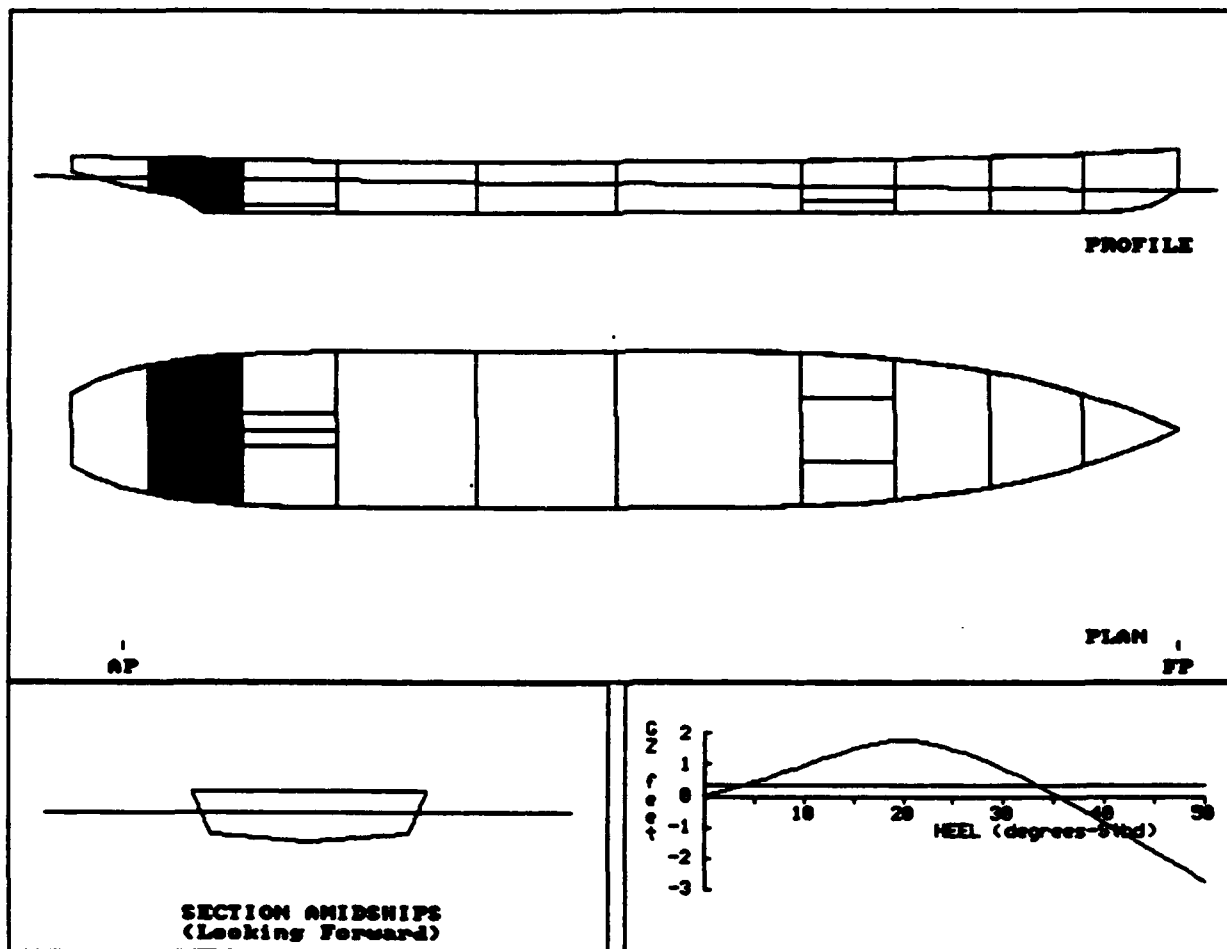

RTRN009A:
 180'ER W/LIFEBTS

COMPARTMENT FLOODING SUMMARY

At 0.0o Heel	PERM.	FLOODED WTR LTons	% FULL (Damaged)	% FULL (Intact)	SP.VOL. ft3/LT	OUTFLOW LTons
LAZARETTE	0.95	32.4	FREE	0.0	----	----
Totals		32.4				

INTACT DATA

Draft at AP = 8.146 ft	KMT = 23.326 ft	LCG = 98.786A ft-FP
Draft at FP = 6.057 ft	VCG = 17.570 ft	LCB = 98.940A ft-FP
Displacement = 738.6 LTons	GMT = 5.756 ft	TCG = 0.000 ft-CL

DRAFT/GZ DATA

HEEL degrees	RIGHTING ARM ft	DRAFT AFT ft	DRAFT FWD ft	FLOODED WATER LTons
0.00	0.000	9.007	5.455	32.4
5.00S	0.458	8.988	5.423	32.8
7.00S	0.651	8.957	5.408	33.2
10.00S	0.958	8.874	5.391	33.9
20.00S	1.765	8.562	5.080	39.7
22.00S	1.703	8.527	4.958	40.7
30.00S	0.865	8.478	4.367	43.7
40.00S	-0.805	8.563	3.387	46.3
50.00S	-2.742	8.758	2.112	48.0

Note: Drafts are measured at A.P. and F.P along ship's centerline

GZ SUMMARY (Evaluated per IMO (SOLAS'90) Rules for Passenger Ships)

	Available	Required
Static Heel Angle	0.00 deg	7.00 deg
Angle at Maximum GZ	21.00S deg	
Maximum GZ	1.765 ft	0.328 ft
Range of Positive GZ	35.49 deg	15.00 deg
Gmt (upright damaged)	5.168 ft	
Righting Area (0.00-7.00)	22.699 ft-deg	2.820 ft-deg

RTRN010A:
 180'ER W/LIFEBTS

Imaged Compartments:
 AFTVOID

	DISPLACEMENT LTons	DRAFT AFT ft	DRAFT FWD ft	TRIM ft	HEEL deg.	UPRIGHT GMT ft
INTACT	738.6	8.146	6.057	2.089A	0.00	5.756
DAMAGED	739.7	8.176	6.036	2.140A	0.00	5.514

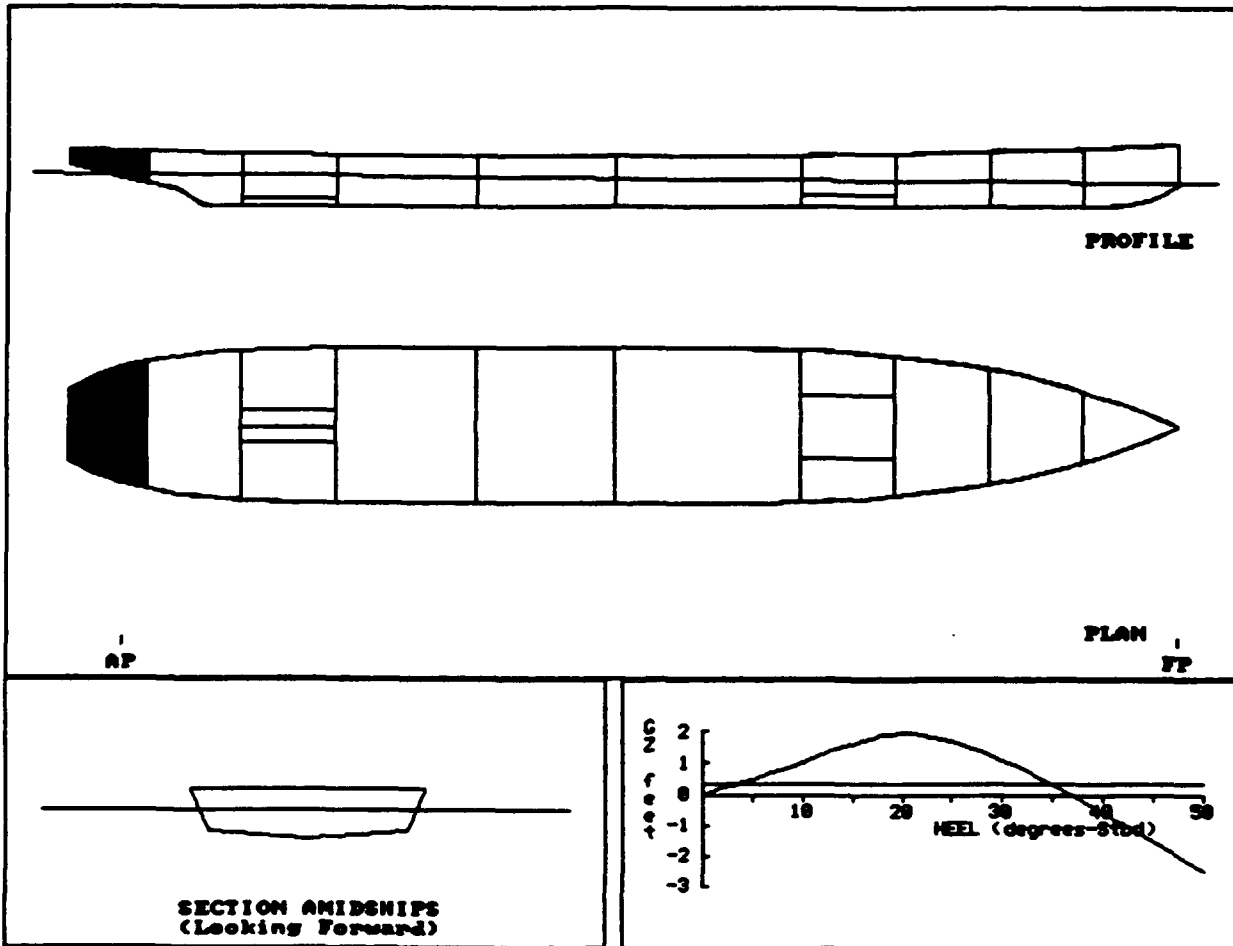

RTRN010A:
 180'ER W/LIFEBTS

COMPARTMENT FLOODING SUMMARY

At 0.0o Heel	PERM.	FLOODED WTR LTons	% FULL (Damaged)	% FULL (Intact)	SP.VOL. ft3/LT	OUTFLOW LTons
AFTVOID	0.95	1.1	FREE	0.0	----	----
Totals		1.1				

INTACT DATA

Draft at AP = 8.146 ft	KMt = 23.326 ft	LCG = 98.786A ft-FP
Draft at FP = 6.057 ft	VCG = 17.570 ft	LCB = 98.940A ft-FP
Displacement = 738.6 LTons	GMT = 5.756 ft	TCG = 0.000 ft-CL

DRAFT/GZ DATA

HEEL degrees	RIGHTING ARM ft	DRAFT AFT ft	DRAFT FWD ft	FLOODED WATER LTons
0.00	0.000	8.176	6.036	1.1
5.00S	0.488	8.151	6.007	1.1
7.00S	0.693	8.112	5.997	1.1
10.00S	1.015	8.011	5.992	1.1
20.00S	1.936	7.387	5.844	1.3
22.00S	1.896	7.257	5.762	1.6
30.00S	1.107	6.822	5.330	3.6
40.00S	-0.558	6.340	4.601	6.3
50.00S	-2.514	5.794	3.650	8.6

Note: Drafts are measured at A.P. and F.P along ship's centerline

GZ SUMMARY (Evaluated per IMO (SOLAS'90) Rules for Passenger Ships)

	Available	Required
Static Heel Angle	0.00 deg	7.00 deg
Angle at Maximum GZ	21.00S deg	
Maximum GZ	1.936 ft	0.328 ft
Range of Positive GZ	36.93 deg	15.00 deg
Gmt (upright damaged)	5.514 ft	
Righting Area (0.00-7.00)	24.445 ft-deg	2.820 ft-deg

RTRN011A:
 180'ER W/LIFEBOATS

Imaged Compartments:

VOID/FO TANK FO TANK STBD

	DISPLACEMENT LTons	DRAFT AFT ft	DRAFT FWD ft	TRIM ft	HEEL deg.	UPRIGHT GMT ft
INTACT	738.6	8.146	6.057	2.089A	0.00	5.756
DAMAGED	800.0	9.482	5.278	4.204A	0.37S	4.509

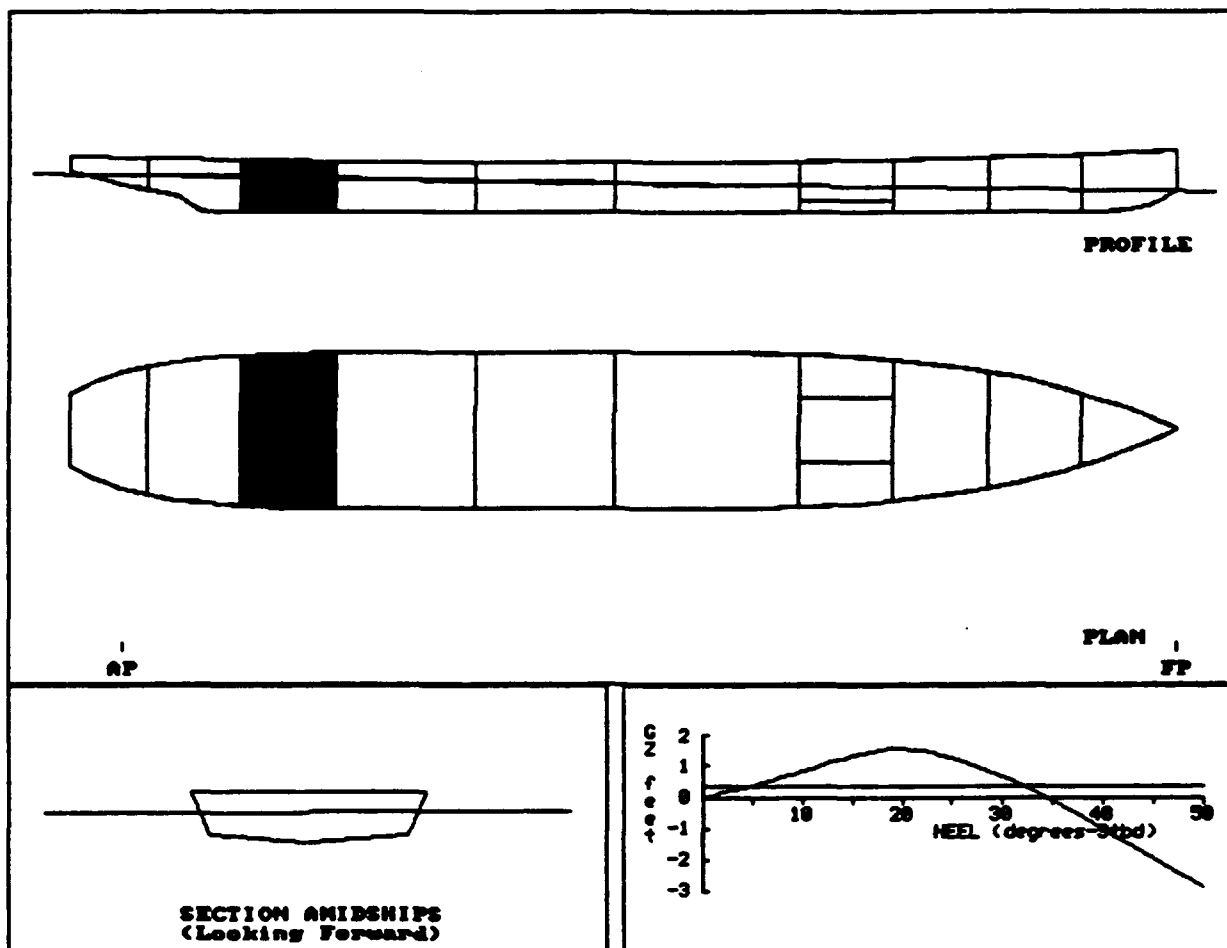

RTRN011A:
 180'ER W/LIFEBTS

COMPARTMENT FLOODING SUMMARY

At 0.4oS Heel	PERM.	FLOODED WTR LTons	% FULL (Damaged)	% FULL (Intact)	SP.VOL. ft3/LT	OUTFLOW LTons
VOID/FO TANK	0.95	51.0	FREE	0.0	----	----
FO TANK STBD	0.95	12.1	FREE	10.0	40.8000	1.7
Totals		63.1				1.7

INTACT DATA

Draft at AP = 8.146 ft KMT = 23.326 ft LCG = 98.786A ft-FP
 Draft at FP = 6.057 ft VCG = 17.570 ft LCB = 98.940A ft-FP
 Displacement = 738.6 LTons GMT = 5.756 ft TCG = 0.000 ft-CL

DRAFT/GZ DATA

HEEL degrees	RIGHTING ARM ft	DRAFT AFT ft	DRAFT FWD ft	FLOODED WATER LTons
0.00	-0.029	9.483	5.280	63.1
5.00S	0.372	9.462	5.253	63.8
7.00S	0.543	9.429	5.239	64.2
10.00S	0.820	9.336	5.232	64.8
20.00S	1.560	9.012	4.979	67.1
22.00S	1.493	8.985	4.871	67.3
30.00S	0.657	8.983	4.325	68.2
40.00S	-0.994	9.177	3.383	69.4
50.00S	-2.898	9.556	2.138	70.7

Note: Drafts are measured at A.P. and F.P along ship's centerline

GZ SUMMARY (Evaluated per IMO (SOLAS'90) Rules for Passenger Ships)
 Available Required

Static Heel Angle	0.37S deg	7.00 deg
Angle at Maximum GZ	21.00S deg	
Maximum GZ	1.560 ft	0.328 ft
Range of Positive GZ	33.92 deg	15.00 deg
Righting Area (0.37-7.00)	19.661 ft-deg	2.820 ft-deg

**APPENDIX B
HYDROSTATICS AND
DAMAGE STABILITY
OUTPUT**

84' FERRY

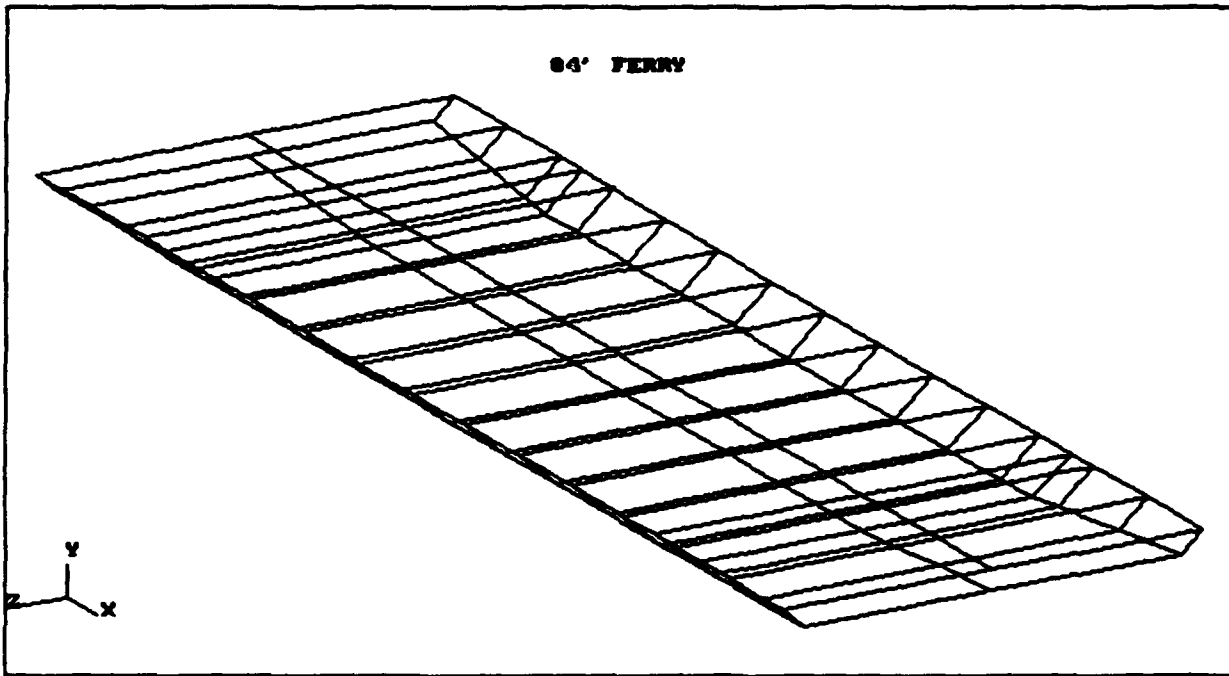

DAMAGE STABILITY SUMMARY
84' FERRY

CASE No.	FILE NAME	DAMAGED COMP.	LISTING	---Intact Condition---			-----Equilibrium Condition After Damage-----					
				MW.DRAFT (ft)	VCG (ft)	GMt (ft)	HEEL (deg)	MAX.GZ (ft)	RANGE (deg)	AREA (ft-deg)	DAM.GMt (ft)	SURVIVAL
1	OPER001A	1		1.825	5.840	28.962	0.0	4.518	50.00	75.33	27.096	Yes
2	OPER002A	2		1.825	5.840	28.962	0.0	3.968	50.00	67.03	25.713	Yes
3	OPER003A	3		1.825	5.840	28.962	0.0	3.070	50.00	53.13	24.269	Yes
4	OPER004A	4		1.825	5.840	28.962	0.0	3.426	50.00	58.95	24.287	Yes
5	OPER005A	5		1.825	5.840	28.962	0.0	3.150	50.00	54.48	24.387	Yes
6	OPER006A	6		1.825	5.840	28.962	0.0	3.969	50.00	67.05	25.713	Yes
7	OPER007A	7		1.825	5.840	28.962	0.0	4.518	50.00	75.33	27.096	Yes

HYDROSTATIC TABLES
 84' FERRY

MAX. DRAFT (ft)	0.500	1.000	1.500	1.830	2.000	2.500	3.000
DISP.MLD. (LTons-SW)	19	42	69	88	99	129	160
DISP.TOTAL (LTons-SW)	19	42	69	89	99	129	161
DISP.TOTAL (LTons-FW)	19	41	68	87	97	126	157
LCB (ft-FP)	42.000A	42.000A	42.000A	42.000A	42.000A	42.000A	42.000A
LCB (forebody) (ft-FP)	26.865A	25.639A	24.288A	23.570A	23.307A	22.765A	22.422A
LCB (aftbody) (ft-FP)	57.135A	58.361A	59.712A	60.430A	60.693A	61.235A	61.578A
TCB (ft-CL)	0.000	0.000	0.000	0.000	0.000	0.000	0.000
KB (ft)	0.255	0.527	0.811	0.997	1.091	1.364	1.633
BMT (ft)	88.343	52.650	38.773	33.724	31.175	25.966	22.715
KMT (ft)	88.598	53.178	39.584	34.722	32.266	27.330	24.349
BMI (ft)	678.643	517.646	422.422	392.747	355.999	280.189	231.972
KMI (ft)	678.898	518.174	423.233	393.745	357.090	281.552	233.606
TPI (LTons)	3.4	4.1	4.6	4.9	5.0	5.1	5.3
(ft-LTons)	13	22	29	34	35	36	37
(LTons)	-0.0	-0.0	-0.0	-0.0	-0.0	-0.0	-0.0
LCF (ft-FP)	42.000A	42.000A	42.000A	42.000A	42.000A	42.000A	42.000A
M.P. AREA (ft2)	1,416	1,714	1,931	2,068	2,088	2,148	2,208
WETTED SUR. (ft2)	1,447	1,781	2,039	2,220	2,263	2,392	2,521
MAX. BEAM (ft)	22.722	23.435	24.148	24.619	24.861	25.574	26.287
LENGTH W.L. (ft)	64.640	74.320	84.000	84.000	84.000	84.000	84.000
Cb	0.5962	0.6515	0.7113	0.7459	0.7603	0.7950	0.8226
Cb (forebody)	0.5962	0.6515	0.7113	0.7458	0.7603	0.7950	0.8226
Cb (aftbody)	0.5962	0.6515	0.7113	0.7459	0.7603	0.7950	0.8226
Cm	0.8280	0.8413	0.8545	0.8632	0.8677	0.8810	0.8942
Cp	0.7201	0.7744	0.8324	0.8640	0.8762	0.9025	0.9199
Cwp	0.6242	0.7558	0.8516	0.9117	0.9207	0.9471	0.9736
Cit	0.4335	0.5646	0.6810	0.7577	0.7803	0.8496	0.9227

Assumes: See Water at 35.0063 ft3/LT
 Fresh Water at 35.8814 ft3/LT
 Ship floating at even keel (no heel or trim)

OPER001A:
 84' FERRY

Damaged Compartments:

COMP 1

	DISPLACEMENT LTons	DRAFT AFT ft	DRAFT FWD ft	TRIM ft	HEEL deg.	UPRIGHT GMT ft
INTACT	88.6	1.825	1.825	0.000	0.00	28.962
DAMAGED	91.0	1.754	1.978	0.224F	0.00	27.096

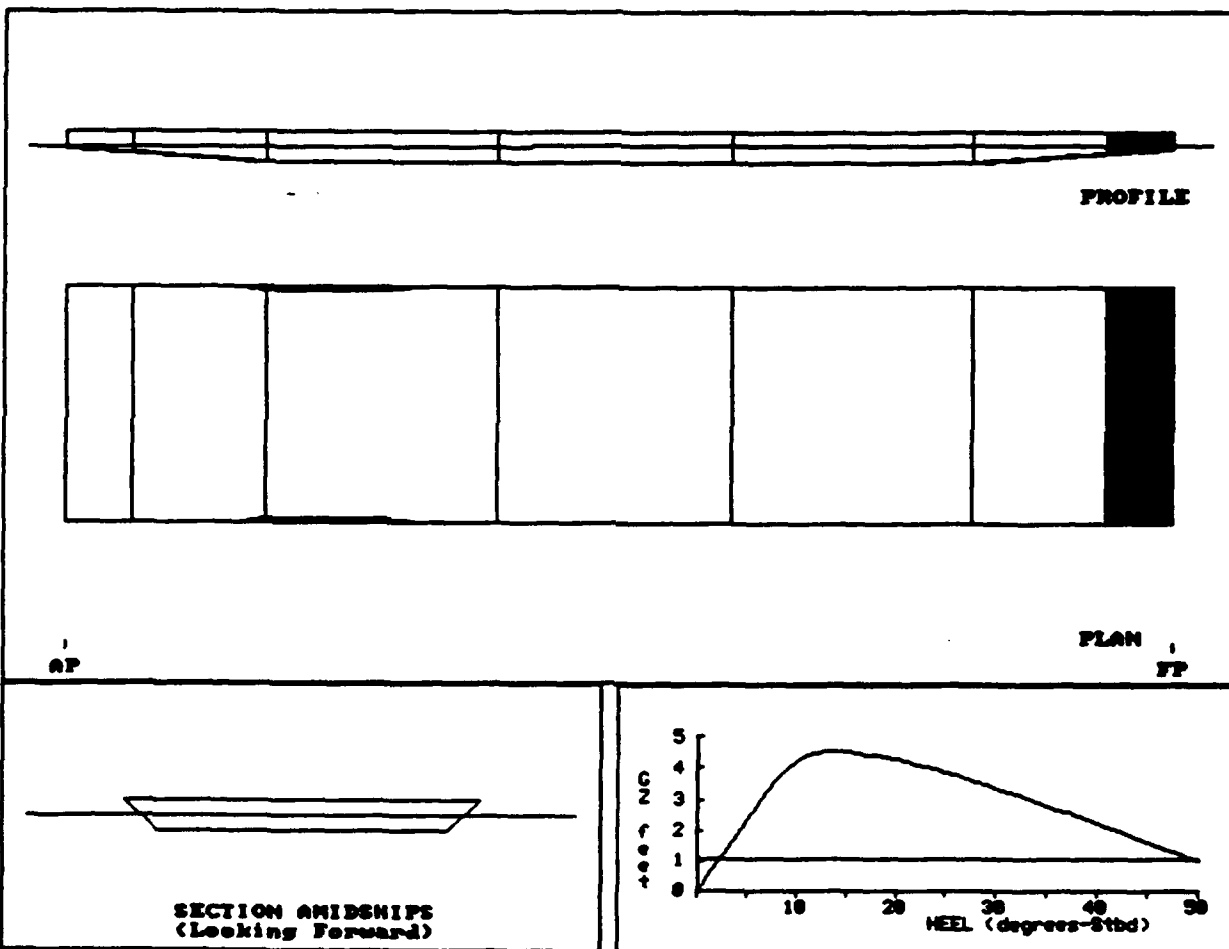

OPER001A:
 84' FERRY

COMPARTMENT FLOODING SUMMARY

At 0.0o Heel	PERM.	FLOODED WTR LTons	% FULL (Damaged)	% FULL (Intact)	SP.VOL. ft3/LT	OUTFLOW LTons
COMPT 1	0.95	2.4	FREE	0.0	----	----
Totals		2.4				

INTACT DATA

Draft at AP = 1.825 ft	KMt = 34.802 ft	LCG = 42.000A ft-FP
Draft at FP = 1.825 ft	VCG = 5.840 ft	LCB = 42.000A ft-FP
Displacement = 88.6 LTons	Gmt = 28.962 ft	TCG = 0.000 ft-CL

DRAFT/GZ DATA

HEEL degrees	RIGHTING ARM ft	DRAFT AFT ft	DRAFT FWD ft	FLOODED WATER LTons
0.00	0.000	1.754	1.978	2.4
5.00S	2.347	1.696	1.959	2.5
10.00S	4.205	1.503	1.983	3.2
15.00S	4.494	1.303	2.099	3.6
20.00S	4.259	1.083	2.233	3.7
30.00S	3.351	0.570	2.555	4.0
40.00S	2.217	-0.084	2.975	4.1
50.00S	0.978	-0.985	3.563	4.2

Note: Drafts are measured at A.P. and F.P along ship's centerline

GZ SUMMARY (Evaluated per IMO (SOLAS'90) Rules for Passenger Ships)

	Available	Required
Static Heel Angle	0.00 deg	7.00 deg
Angle at Maximum GZ	15.00S deg	
Maximum GZ	4.518 ft	1.050 ft
Range of Positive GZ	50.00 deg	15.00 deg
Gmt (upright damaged)	27.096 ft	
Righting Area (0.00-7.00)	75.335 ft-deg	2.820 ft-deg

OPER002A:
 84' FERRY

Imaged Compartments:
 COMPT 2

	DISPLACEMENT LTons	DRAFT AFT ft	DRAFT FWD ft	TRIM ft	HEEL deg.	UPRIGHT GMT ft
INTACT	88.6	1.825	1.825	0.000	0.00	28.962
DAMAGED	101.2	1.554	2.513	0.959F	0.00	25.713

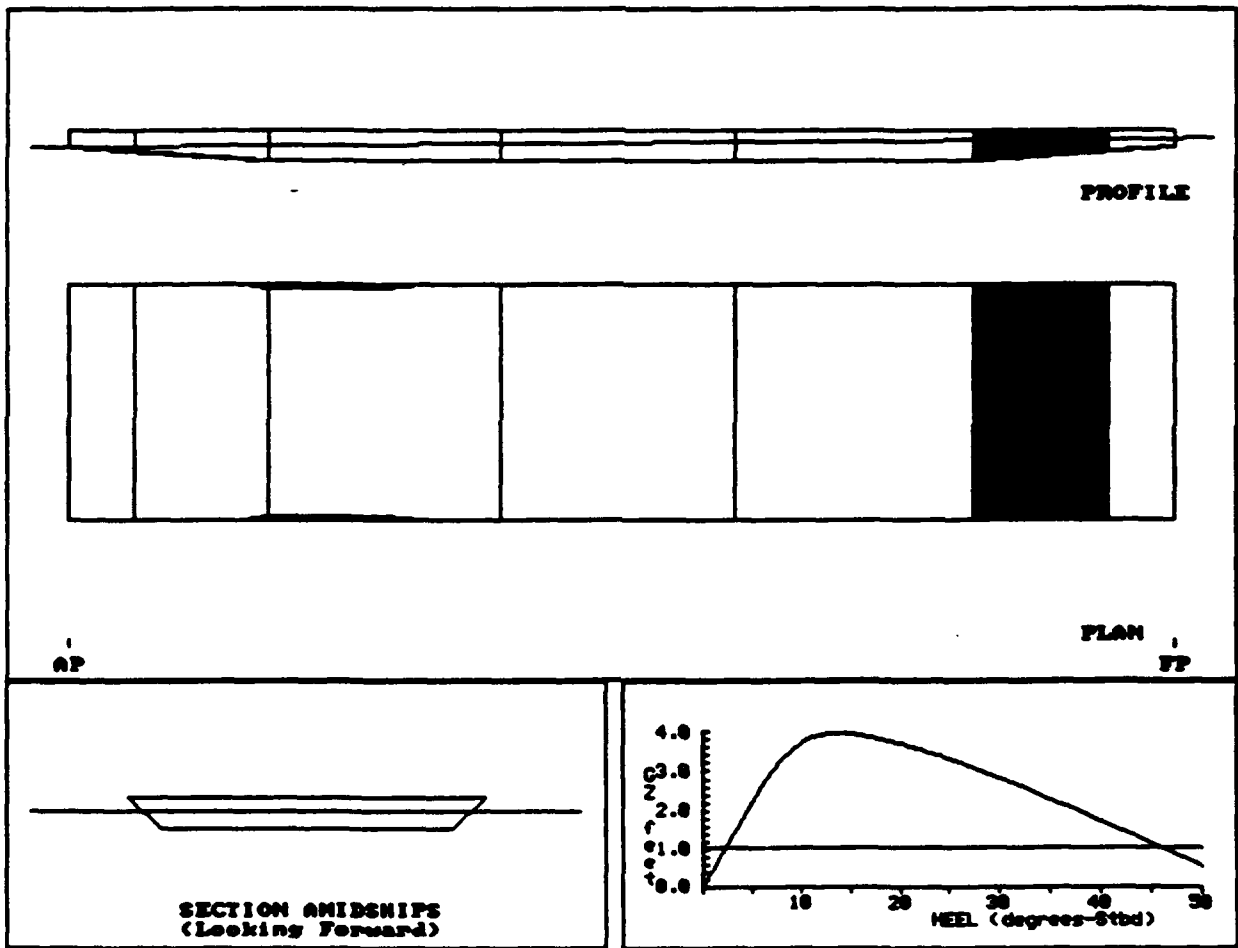

OPER002A:
 84' FERRY

COMPARTMENT FLOODING SUMMARY

At 0.0o Heel	PERM.	FLOODED WTR LTons	% FULL (Damaged)	% FULL (Intact)	SP.VOL. ft ³ /LT	OUTFLOW LTons
COMPT 2	0.95	12.6	FREE	0.0	----	----
Totals		12.6				

INTACT DATA

Draft at AP = 1.825 ft	KMT = 34.802 ft	LCG = 42.000A ft-FP
Draft at FP = 1.825 ft	VCG = 5.840 ft	LCB = 42.000A ft-FP
Displacement = 88.6 LTons	GMT = 28.962 ft	TCG = 0.000 ft-CL

DRAFT/GZ DATA

HEEL degrees	RIGHTING ARM ft	DRAFT AFT ft	DRAFT FWD ft	FLOODED WATER LTons
0.00	0.000	1.554	2.513	12.6
5.00S	2.223	1.485	2.500	12.7
10.00S	3.720	1.209	2.722	12.8
15.00S	3.948	0.853	3.205	13.1
20.00S	3.707	0.460	3.746	13.3
30.00S	2.822	-0.458	5.001	13.6
40.00S	1.734	-1.664	6.637	13.8
50.00S	0.565	-3.328	8.887	13.9

Note: Drafts are measured at A.P. and F.P along ship's centerline

GZ SUMMARY (Evaluated per IMO (SOLAS'90) Rules for Passenger Ships)

	Available	Required
Static Heel Angle	0.00 deg	7.00 deg
Angle at Maximum GZ	15.00S deg	
Maximum GZ	3.968 ft	1.050 ft
Range of Positive GZ	50.00 deg	15.00 deg
Gmt (upright damaged)	25.713 ft	
Righting Area (0.00-%.00)	67.035 ft-deg	2.820 ft-deg

OPER003A:
 84' FERRY

Imaged Compartments:
 COMPT 3

	DISPLACEMENT LTons	DRAFT AFT ft	DRAFT FWD ft	TRIM ft	HEEL deg.	UPRIGHT GMT ft
INTACT	88.6	1.825	1.825	0.000	0.00	28.962
DAMAGED	119.5	1.672	2.998	1.326F	0.00	24.269

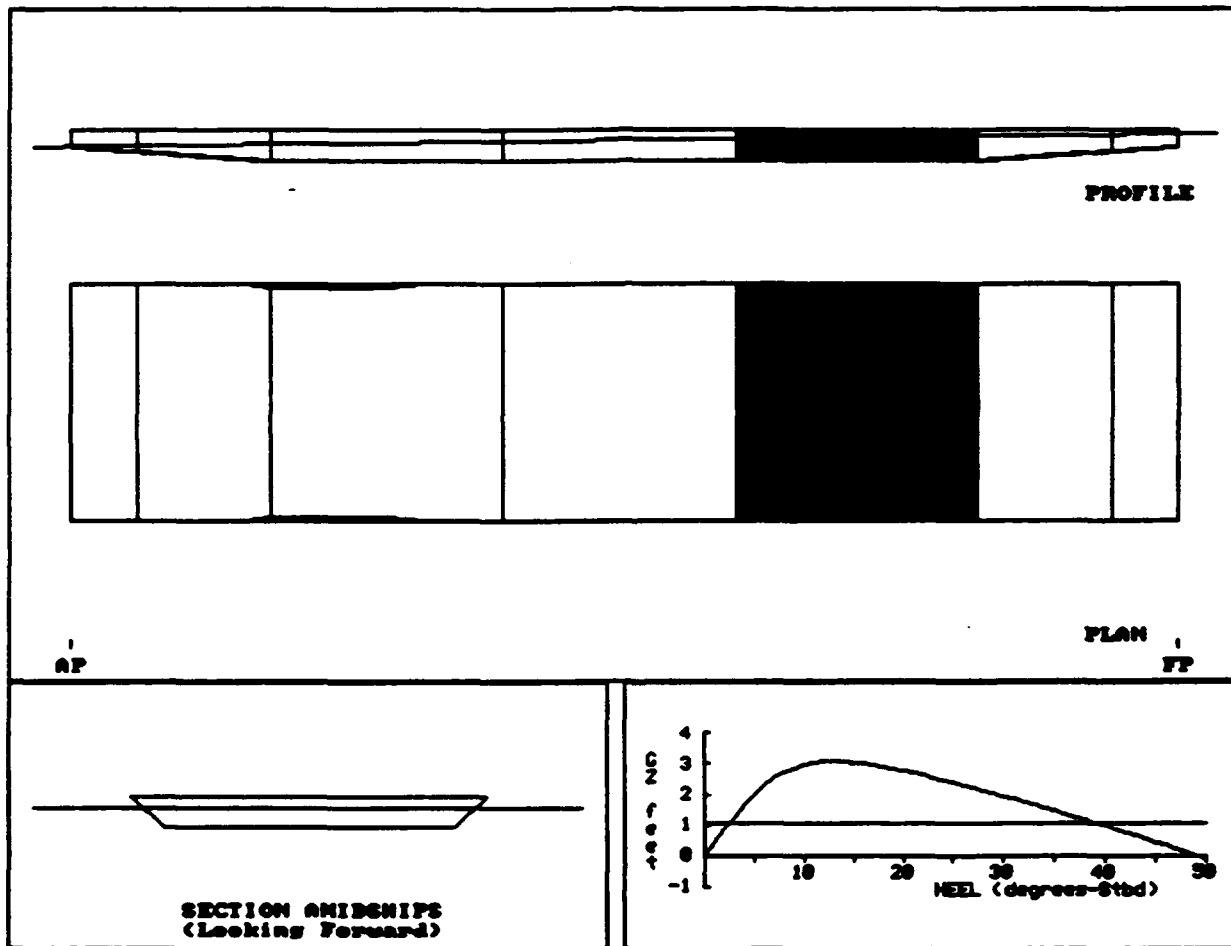

OPER003A:
 84' FERRY

COMPARTMENT FLOODING SUMMARY

At 0.0o Heel	PERM.	FLOODED WTR LTons	% FULL (Damaged)	% FULL (Intact)	SP.VOL. ft3/LT	OUTFLOW LTons
COMPT 3	0.95	30.9	FREE	0.0	----	----
Totals		30.9				

INTACT DATA

Draft at AP = 1.825 ft	Kmt = 34.802 ft	LCG = 42.000A ft-FP
Draft at FP = 1.825 ft	VCG = 5.840 ft	LCB = 42.000A ft-FP
Displacement = 88.6 LTons	Gmt = 28.962 ft	TCG = 0.000 ft-CL

DRAFT/GZ DATA

HEEL degrees	RIGHTING ARM ft	DRAFT AFT ft	DRAFT FWD ft	FLOODED WATER LTons
0.00	0.000	1.672	2.998	30.9
5.00S	1.975	1.585	3.057	31.3
10.00S	2.951	1.309	3.546	31.4
15.00S	3.034	1.043	4.292	31.5
20.00S	2.775	0.740	5.149	31.4
30.00S	1.940	0.007	7.150	31.3
40.00S	0.952	-0.949	9.681	31.3
50.00S	-0.086	-2.271	13.134	31.4

Note: Drafts are measured at A.P. and F.P along ship's centerline

GZ SUMMARY (Evaluated per IMO (SOLAS'90) Rules for Passenger Ships)
 Available Required

Static Heel Angle	0.00 deg	7.00 deg
Angle at Maximum GZ	14.00S deg	
Maximum GZ	3.070 ft	1.050 ft
Range of Positive GZ	50.00 deg	15.00 deg
Gmt (upright damaged)	24.269 ft	
Righting Area (0.00- $\frac{1}{2}$.00)	53.132 ft-deg	2.820 ft-deg

OPER004A:
 84' FERRY

Imaged Compartments:
 COMPT 4

	DISPLACEMENT LTons	DRAFT AFT ft	DRAFT FWD ft	TRIM ft	HEEL deg.	UPRIGHT Gmt ft
INTACT	88.6	1.825	1.825	0.000	0.00	28.962
DAMAGED	114.6	2.266	2.251	0.016A	0.00	24.287

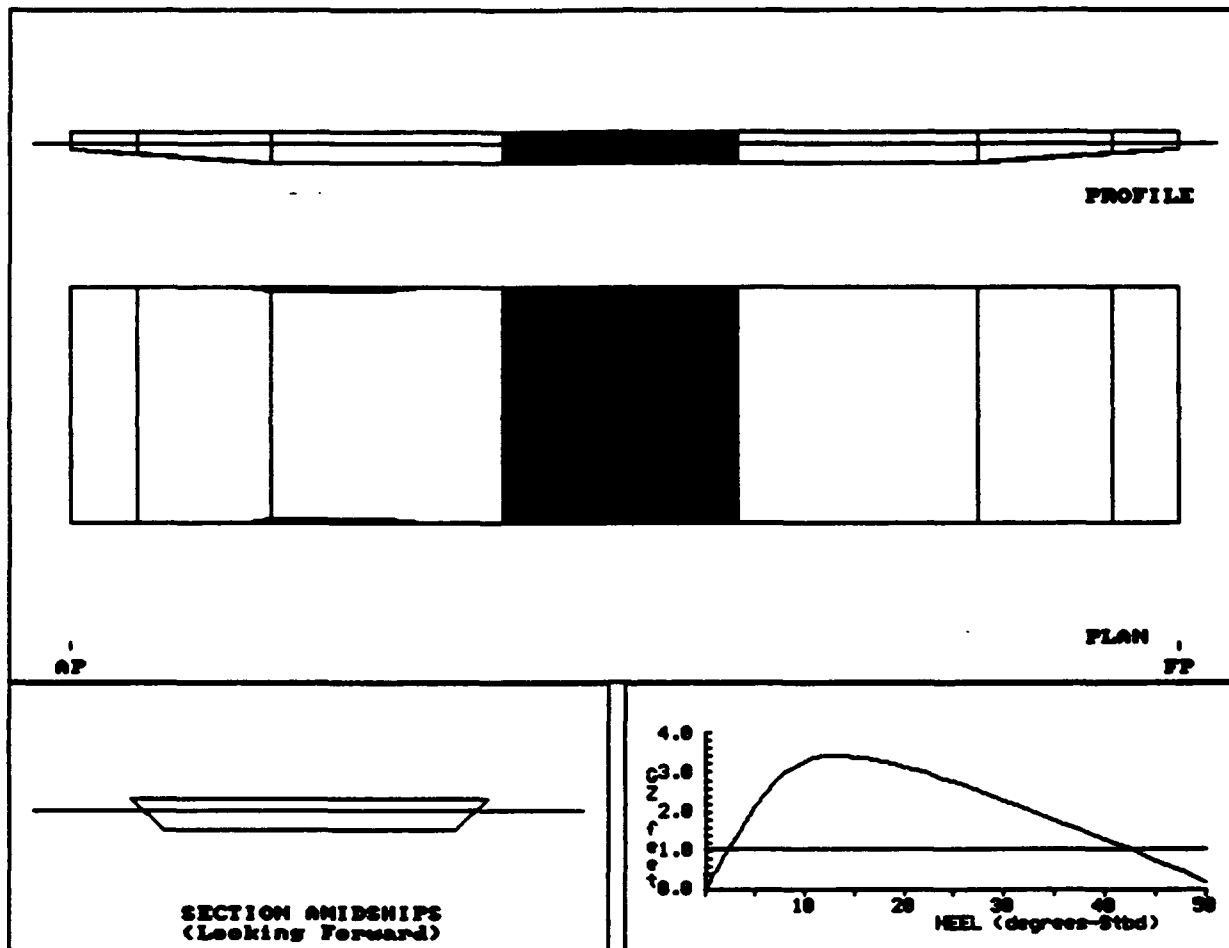

OPER004A:
 84' FERRY

COMPARTMENT FLOODING SUMMARY

At 0.0o Heel	PERM.	FLOODED WTR LTons	% FULL (Damaged)	% FULL (Intact)	SP.VOL. ft3/LT	OUTFLOW LTons
COMPT 4	0.95	26.1	FREE	0.0	----	----
Totals		26.1				

INTACT DATA

Draft at AP = 1.825 ft	Kmt = 34.802 ft	LCG = 42.000A ft-FP
Draft at FP = 1.825 ft	VCG = 5.840 ft	LCB = 42.000A ft-FP
Displacement = 88.6 LTons	Gmt = 28.962 ft	TCG = 0.000 ft-CL

DRAFT/GZ DATA

HEEL degrees	RIGHTING ARM ft	DRAFT AFT ft	DRAFT FWD ft	FLOODED WATER LTons
0.00	0.000	2.266	2.251	26.1
5.00S	2.122	2.231	2.214	26.0
10.00S	3.273	2.275	2.250	25.8
15.00S	3.395	2.468	2.434	25.4
20.00S	3.143	2.681	2.633	25.2
30.00S	2.299	3.154	3.079	25.0
40.00S	1.287	3.734	3.623	24.9
50.00S	0.207	4.516	4.356	24.8

Note: Drafts are measured at A.P. and F.P along ship's centerline

GZ SUMMARY (Evaluated per IMO (SOLAS'90) Rules for Passenger Ships)
 Available Required

Static Heel Angle	0.00 deg	7.00 deg
Angle at Maximum GZ	14.00S deg	
Maximum GZ	3.426 ft	1.050 ft
Range of Positive GZ	50.00 deg	15.00 deg
Gmt (upright damaged)	24.287 ft	
Righting Area (0.00-%.00)	58.947 ft-deg	2.820 ft-deg

OPER005A:
 84' FERRY

Imaged Compartments:
 COMPT 5

	DISPLACEMENT LTons	DRAFT AFT ft	DRAFT FWD ft	TRIM ft	HEEL deg.	UPRIGHT GMT ft
INTACT	88.6	1.825	1.825	0.000	0.00	28.962
DAMAGED	118.4	2.965	1.668	1.297A	0.00	24.387

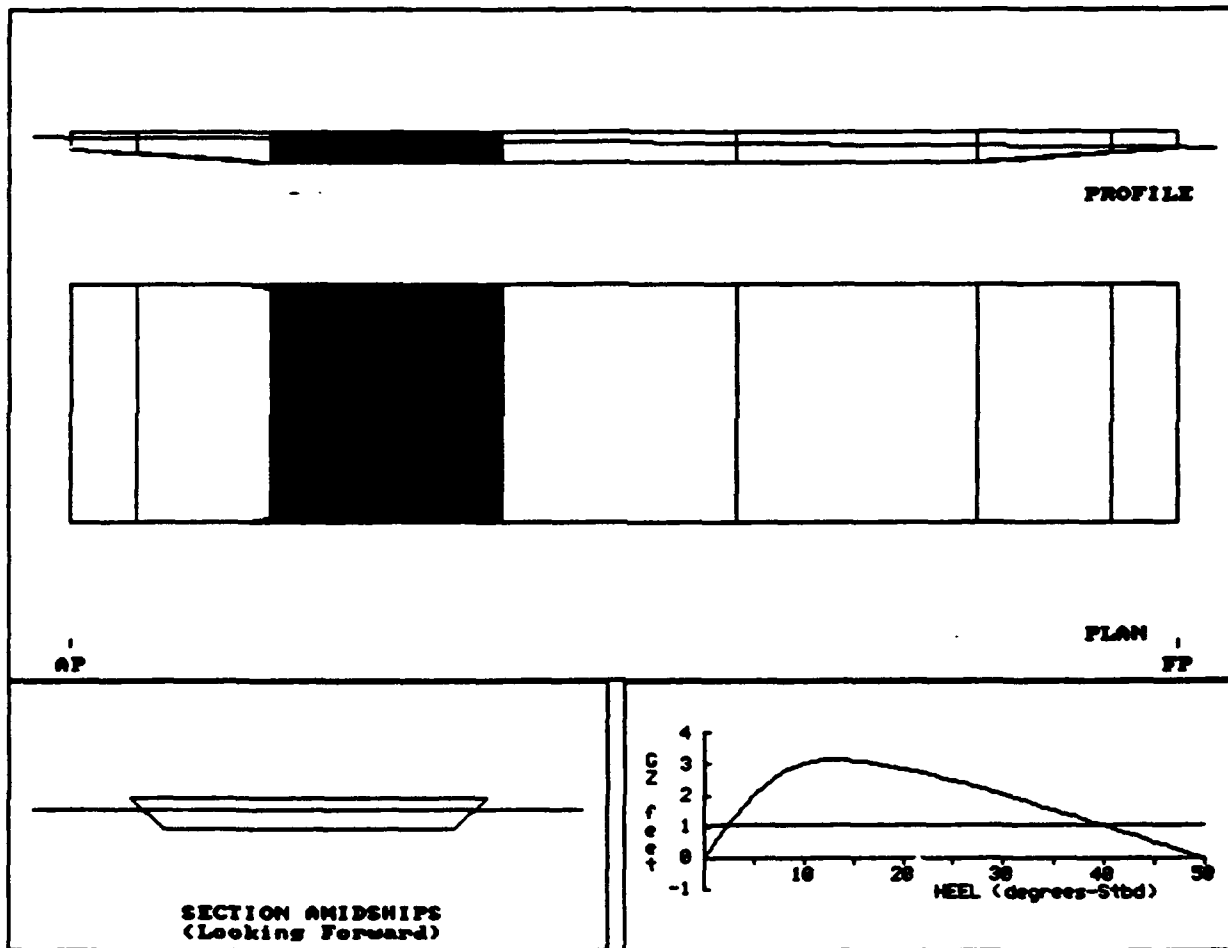

OPER005A:
 84' FERRY

COMPARTMENT FLOODING SUMMARY

At 0.0o Heel	PERM.	FLOODED WTR LTons	% FULL (Damaged)	% FULL (Intact)	SP.VOL. ft3/LT	OUTFLOW LTons
COMPT 5	0.95	29.8	FREE	0.0	----	----
Totals		29.8				

INTACT DATA

Draft at AP = 1.825 ft KMT = 34.802 ft LCG = 42.000A ft-FP
 Draft at FP = 1.825 ft VCG = 5.840 ft LCB = 42.000A ft-FP
 Displacement = 88.6 LTons GMT = 28.962 ft TCG = 0.000 ft-CL

DRAFT/GZ DATA

HEEL degrees	RIGHTING ARM ft	DRAFT AFT ft	DRAFT FWD ft	FLOODED WATER LTons
0.00	0.000	2.965	1.668	29.8
5.00S	2.014	3.010	1.585	30.0
10.00S	3.023	3.473	1.313	30.1
15.00S	3.116	4.196	1.046	30.2
20.00S	2.858	5.022	0.745	30.1
30.00S	2.019	6.951	0.016	30.0
40.00S	1.024	9.389	-0.935	30.0
50.00S	-0.025	12.718	-2.251	30.1

Note: Drafts are measured at A.P. and F.P along ship's centerline

GZ SUMMARY (Evaluated per IMO (SOLAS'90) Rules for Passenger Ships)
 Available Required

Static Heel Angle	0.00 deg	7.00 deg
Angle at Maximum GZ	14.00S deg	
Maximum GZ	3.150 ft	1.050 ft
Range of Positive GZ	50.00 deg	15.00 deg
Gmt (upright damaged)	24.387 ft	
Righting Area (0.00-%.00)	54.478 ft-deg	2.820 ft-deg

OPER006A:
 84' FERRY

Imaged Compartments:
 COMPT 6

	DISPLACEMENT LTons	DRAFT AFT ft	DRAFT FWD ft	TRIM ft	HEEL deg.	UPRIGHT Gmt ft
INTACT	88.6	1.825	1.825	0.000	0.00	28.962
DAMAGED	101.2	2.513	1.554	0.959A	0.00	25.713

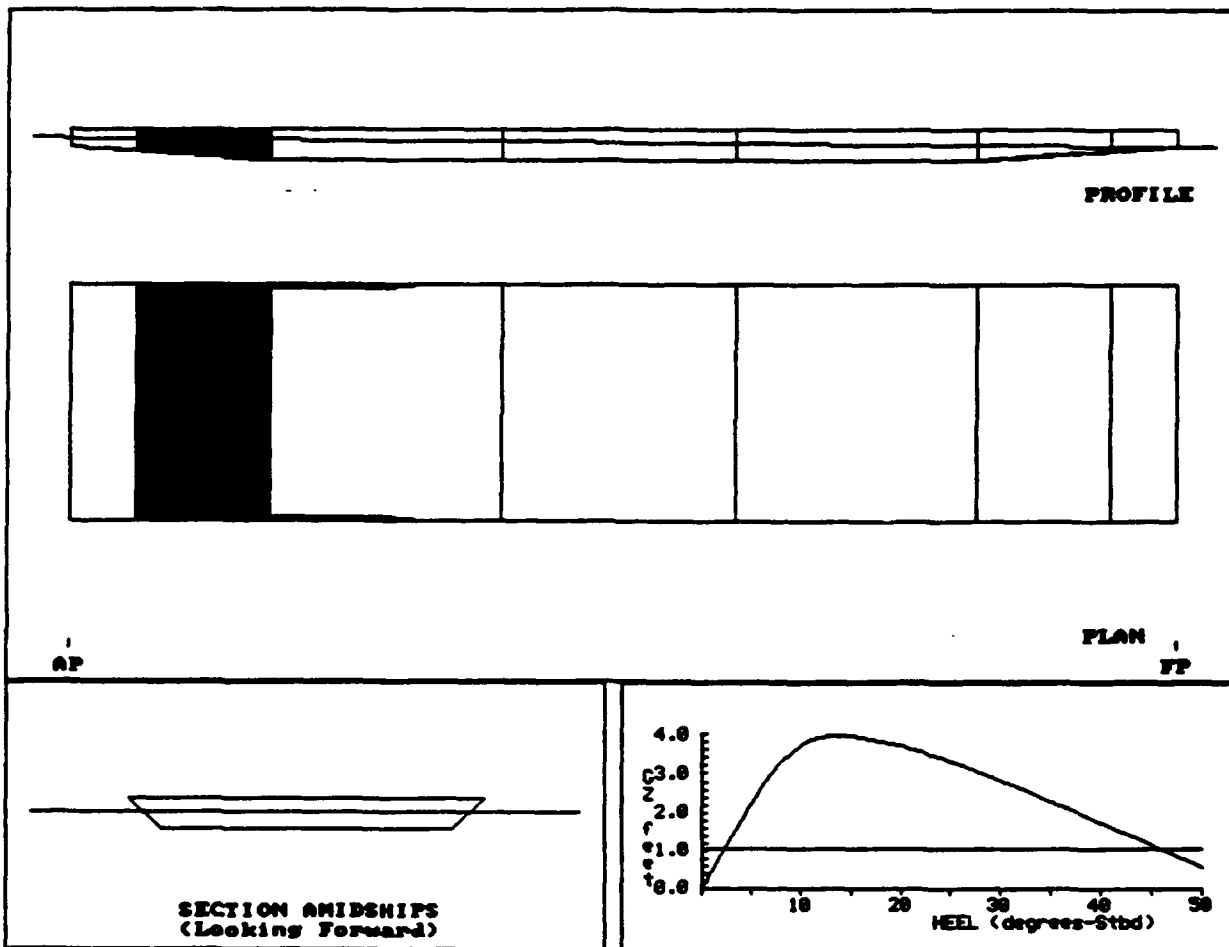

OPER006A:
 84' FERRY

COMPARTMENT FLOODING SUMMARY

At 0.0o Heel	PERM.	FLOODED WTR LTons	% FULL (Damaged)	% FULL (Intact)	SP.VOL. ft3/LT	OUTFLOW LTons
COMPT 6	0.95	12.6	FREE	0.0	----	----
Totals		12.6				

INTACT DATA

Draft at AP = 1.825 ft	KMT = 34.802 ft	LCG = 42.000A ft-FP
Draft at FP = 1.825 ft	VCG = 5.840 ft	LCB = 42.000A ft-FP
Displacement = 88.6 LTons	GMT = 28.962 ft	TCG = 0.000 ft-CL

DRAFT/GZ DATA

HEEL degrees	RIGHTING ARM ft	DRAFT AFT ft	DRAFT FWD ft	FLOODED WATER LTons
0.00	0.000	2.513	1.554	12.6
5.00S	2.224	2.500	1.486	12.7
10.00S	3.721	2.721	1.209	12.8
15.00S	3.949	3.204	0.853	13.1
20.00S	3.708	3.745	0.460	13.3
30.00S	2.823	4.999	-0.457	13.6
40.00S	1.735	6.635	-1.663	13.8
50.00S	0.566	8.884	-3.326	13.9

Note: Drafts are measured at A.P. and F.P along ship's centerline

GZ SUMMARY (Evaluated per IMO (SOLAS'90) Rules for Passenger Ships)
 Available Required

Static Heel Angle	0.00 deg	7.00 deg
Angle at Maximum GZ	15.00S deg	
Maximum GZ	3.969 ft	1.050 ft
Range of Positive GZ	50.00 deg	15.00 deg
Gmt (upright damaged)	25.713 ft	
Righting Area (0.00-1.00)	67.050 ft-deg	2.820 ft-deg

OPER007A:
 84' FERRY

Damaged Compartments:
 COMP 7

	DISPLACEMENT LTons	DRAFT AFT ft	DRAFT FWD ft	TRIM ft	HEEL deg.	UPRIGHT GMT ft
INTACT	88.6	1.825	1.825	0.000	0.00	28.962
DAMAGED	91.0	1.978	1.754	0.224A	0.00	27.096

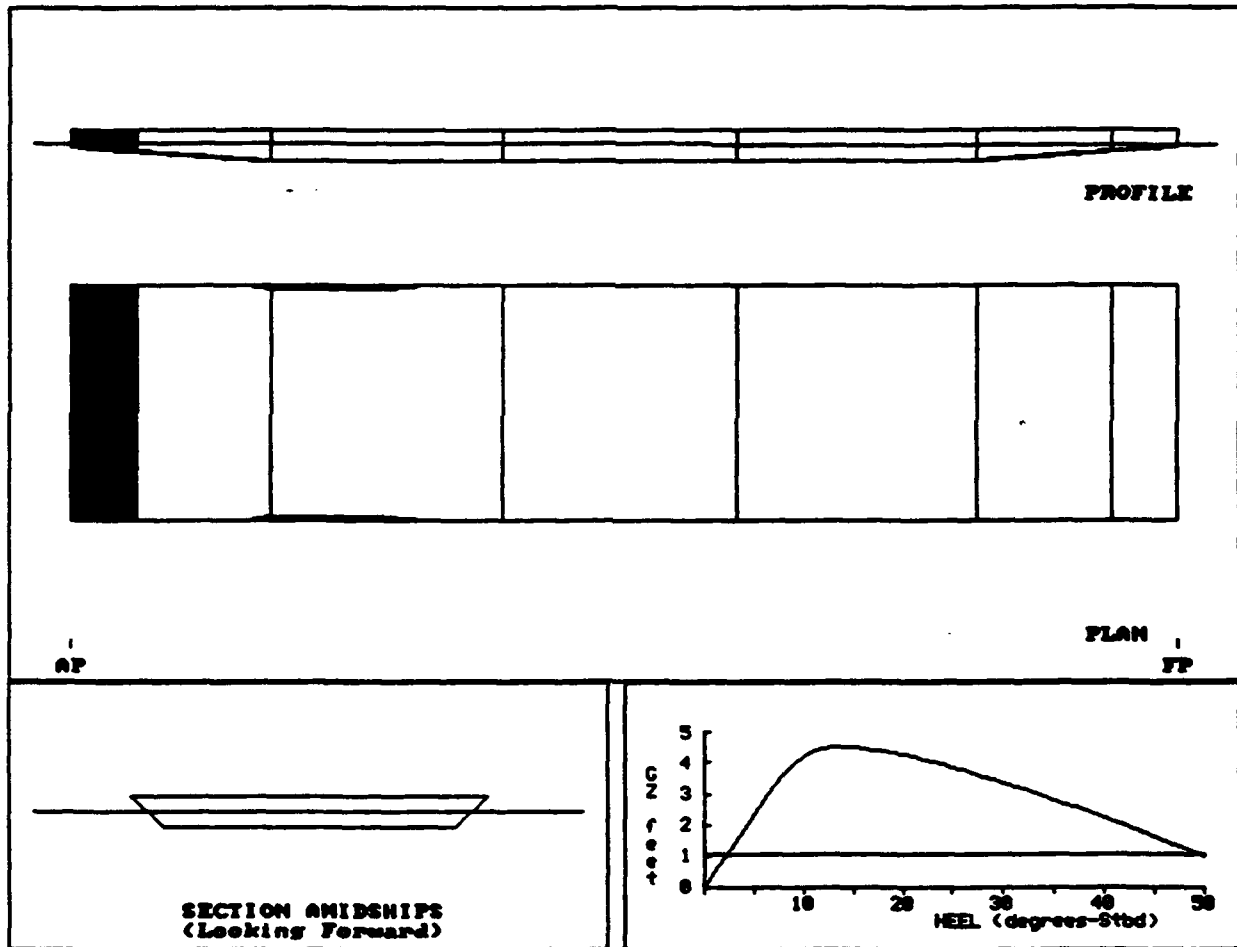

OPER007A:
 84' FERRY

COMPARTMENT FLOODING SUMMARY

At 0.0o Heel	PERM.	FLOODED WTR LTons	% FULL (Damaged)	% FULL (Intact)	SP.VOL. ft3/LT	OUTFLOW LTons
COMPT 7	0.95	2.4	FREE	0.0	----	----
Totals		2.4				

INTACT DATA

Draft at AP = 1.825 ft	Kmt = 34.802 ft	LCG = 42.000A ft-FP
Draft at FP = 1.825 ft	VCG = 5.840 ft	LCB = 42.000A ft-FP
Displacement = 88.6 LTons	GMT = 28.962 ft	TCG = 0.000 ft-CL

DRAFT/GZ DATA

HEEL degrees	RIGHTING ARM ft	DRAFT AFT ft	DRAFT FWD ft	FLOODED WATER LTons
0.00	0.000	1.978	1.754	2.4
5.00S	2.347	1.959	1.696	2.5
10.00S	4.205	1.983	1.503	3.2
15.00S	4.494	2.099	1.303	3.6
20.00S	4.259	2.233	1.083	3.7
30.00S	3.351	2.555	0.570	4.0
40.00S	2.217	2.975	-0.084	4.1
50.00S	0.978	3.563	-0.985	4.2

Note: Drafts are measured at A.P. and F.P along ship's centerline

GZ SUMMARY (Evaluated per IMO (SOLAS'90) Rules for Passenger Ships)
 Available Required

Static Heel Angle	0.00 deg	7.00 deg
Angle at Maximum GZ	15.00S deg	
Maximum GZ	4.518 ft	1.050 ft
Range of Positive GZ	50.00 deg	15.00 deg
Gmt (upright damaged)	27.096 ft	
Righting Area (0.00-%.00)	75.335 ft-deg	2.820 ft-deg

**APPENDIX B
HYDROSTATICS AND
DAMAGE STABILITY
OUTPUT**

175' FERRY

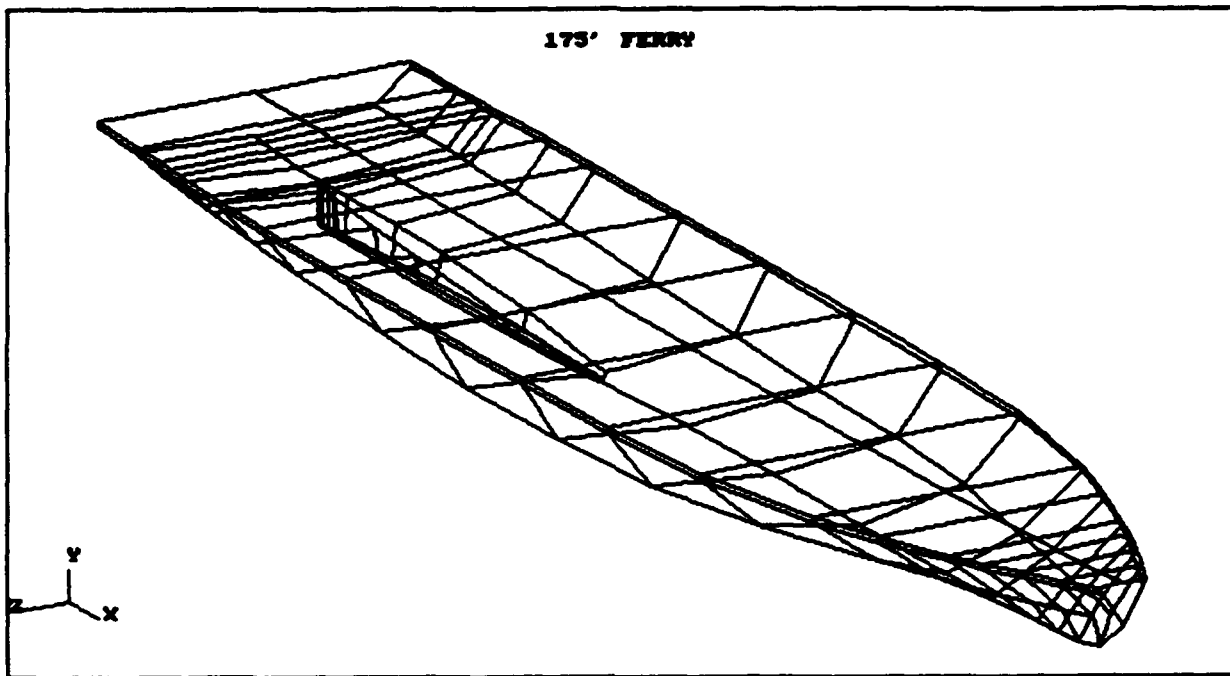

**DAMAGE STABILITY SUMMARY
 175' FERRY**

CASE No.	FILE NAME	DAMAGED COMP. LISTING	---Intact Condition---			-----Equilibrium Condition After Damage-----						
			MN.DRAFT (ft)	VCG (ft)	GMT (ft)	HEEL (deg)	MAX.GZ (ft)	RANGE (deg)	AREA (ft-deg)	DAM.GMT (ft)	SURVIVAL	
1	DPTA001A	1	8.383	19.050	3.944	0.0	1.300	34.05	16.16	3.973	No	*F
2	DPTA002A	1,2	8.383	19.050	3.944	0.0	1.096	30.80	14.99	3.760	No	*F
3	DPTA003A	2	8.383	19.050	3.944	0.0	1.160	32.19	15.34	3.858	No	*F
4	DPTA004A	3	8.383	19.050	3.944	0.0	1.026	31.51	13.80	3.555	No	*F
5	DPTA005A	4	8.383	19.050	3.944	0.0	0.897	30.08	12.34	3.258	No	*F
6	DPTA006A	4,5	8.383	19.050	3.944	0.5P	0.865	29.34	11.63	----	No	*F
7	DPTA007A	7	8.383	19.050	3.944	0.0	1.029	31.00	13.84	3.472	No	*F
8	DPTA008A	8	8.383	19.050	3.944	0.0	1.011	30.84	13.43	3.280	No	*F
9	DPTA009A	9,8	8.383	19.050	3.944	0.0	1.063	31.11	14.16	3.446	No	*F
10	DPTA010A	10	8.383	19.050	3.944	0.0	0.941	29.83	12.64	2.936	No	*F
11	DPTA011A	11	8.383	19.050	3.944	0.0	0.999	31.42	12.33	2.782	No	*F
12	DPTA012A	11,12	8.383	19.050	3.944	0.9P	0.916	29.81	10.95	----	No	*F
13	DPTA013A	14	8.383	19.050	3.944	0.0	1.072	31.72	13.05	2.847	No	*F
14	DPTA014A	15	8.383	19.050	3.944	0.0	1.170	32.56	14.20	3.090	No	*F

*F WARNING: The required GMT for non-survival cases does not meet all survival criteria.

**DAMAGE STABILITY SUMMARY
 175' FERRY**

CASE No.	FILE NAME	DAMAGED COMP. LISTING	---Intact Condition---			-----Equilibrium Condition After Damage-----					
			MN.DRAFT (ft)	VCG (ft)	GMT (ft)	HEEL (deg)	MAX.GZ (ft)	RANGE (deg)	AREA (ft-deg)	DAM.GMT (ft)	SURVIVAL
1	DPA1001A	1	8.383	19.050	3.944	0.0	1.300	34.05	16.16	3.973	Yes
2	DPA1002A	1,2	8.383	19.050	3.944	0.0	1.096	30.80	14.99	3.760	Yes
3	DPA1003A	2	8.383	19.050	3.944	0.0	1.160	32.19	15.34	3.858	Yes
4	DPA1004A	3	8.383	19.050	3.944	0.0	1.026	31.51	13.80	3.555	Yes
5	DPA1005A	4	8.383	19.050	3.944	0.0	0.897	30.08	12.34	3.258	No *F
6	DPA1006A	4,5	8.383	19.050	3.944	0.5P	0.865	29.34	11.63	----	No *F
7	DPA1007A	7	8.383	19.050	3.944	0.0	1.029	31.00	13.84	3.472	Yes
8	DPA1008A	8	8.383	19.050	3.944	0.0	1.011	30.84	13.43	3.280	No *F
9	DPA1009A	9,8	8.383	19.050	3.944	0.0	1.063	31.11	14.16	3.446	Yes
10	DPA1010A	10	8.383	19.050	3.944	0.0	0.941	29.83	12.64	2.936	No *F
11	DPA1011A	11	8.383	19.050	3.944	0.0	0.999	31.42	12.33	2.782	No *F
12	DPA1012A	11,12	8.383	19.050	3.944	0.9P	0.916	29.81	10.95	----	No *F
13	DPA1013A	14	8.383	19.050	3.944	0.0	1.072	31.72	13.05	2.847	Yes
14	DPA1014A	15	8.383	19.050	3.944	0.0	1.170	32.56	14.20	3.090	Yes

*F WARNING: The required GMT for non-survival cases does not meet all survival criteria.

**DAMAGE STABILITY SUMMARY
 175' FERRY**

C No.	FILE NAME	DAMAGED COMP. LISTING	---Intact Condition---			-----Equilibrium Condition After Damage-----					SURVIVAL
			MW.DRAFT (ft)	VCG (ft)	GMt (ft)	HEEL (deg)	MAX.GZ (ft)	RANGE (deg)	AREA (ft-deg)	DAM.GMt (ft)	
1	RTA1001A	1	8.129	19.480	3.852	0.0	1.210	33.48	14.99	3.725	Yes
2	RTA1002A	1,2	8.129	19.480	3.852	0.0	1.025	30.34	13.80	3.459	No *F
3	RTA1003A	2	8.129	19.480	3.852	0.0	1.082	31.65	14.12	3.444	Yes
4	RTA1004A	3	8.129	19.480	3.852	0.0	0.947	30.96	12.57	3.095	No *F
5	RTA1005A	4	8.129	19.480	3.852	0.0	0.824	29.62	11.14	2.853	No *F
6	RTA1006A	4,5	8.129	19.480	3.852	0.2s	0.818	29.29	10.98	----	No *F
7	RTA1007A	7	8.129	19.480	3.852	0.0	0.962	30.65	12.75	3.251	No *F
8	RTA1008A	8	8.129	19.480	3.852	0.0	0.945	30.54	12.37	3.084	No *F
9	RTA1009A	9,8	8.129	19.480	3.852	0.0	0.958	30.44	12.55	3.131	No *F
10	RTA1010A	10	8.129	19.480	3.852	0.0	0.907	29.86	11.90	2.755	No *F
11	RTA1011A	11	8.129	19.480	3.852	0.0	0.952	31.24	11.44	2.658	No *F
12	RTA1012A	11,12	8.129	19.480	3.852	0.9s	0.952	30.23	11.02	----	No *F
13	RTA1013A	14	8.129	19.480	3.852	0.0	1.037	31.61	12.29	2.724	No *F
14	RTA1014A	15	8.129	19.480	3.852	0.0	1.110	32.31	13.42	3.070	Yes

*F WARNING: The required GMt for non-survival cases does not meet all survival criteria.

**DAMAGE STABILITY SUMMARY
 175' FERRY**

C. No.	FILE NAME	DAMAGED COMP. LISTING	---Intact Condition---			-----Equilibrium Condition After Damage-----					
			MN.DRAFT (ft)	VCG (ft)	GMT (ft)	HEEL (deg)	MAX.GZ (ft)	RANGE (deg)	AREA (ft-deg)	DAM.GMT (ft)	SURVIVAL
1	DPB1001A	1	8.638	18.880	3.852	0.0	1.258	33.53	15.94	3.875	Yes
2	DPB1002A	1,2	8.638	18.880	3.852	0.0	1.037	29.86	14.56	3.796	Yes
3	DPB1003A	2	8.638	18.880	3.852	0.0	1.107	31.55	15.04	3.890	Yes
4	DPB1004A	3	8.638	18.880	3.852	0.0	0.984	30.89	13.58	3.579	Yes
5	DPB1005A	4	8.638	18.880	3.852	0.0	0.865	29.36	12.14	3.225	Yes
6	DPB1006A	4,5	8.638	18.880	3.852	0.4P	0.839	28.74	11.54	----	Yes
7	DPB1007A	7	8.638	18.880	3.852	0.0	0.990	30.29	13.61	3.456	Yes
8	DPB1008A	8	8.638	18.880	3.852	0.0	0.971	30.12	13.19	3.223	Yes
9	DPB1009A	9,8	8.638	18.880	3.852	0.0	1.017	30.36	13.85	3.385	Yes
10	DPB1010A	10	8.638	18.880	3.852	0.0	0.891	28.85	12.17	2.909	Yes
11	DPB1011A	11	8.638	18.880	3.852	0.0	0.935	30.67	12.00	2.709	Yes
12	DPB1012A	11,12	8.638	18.880	3.852	0.8P	0.870	29.29	10.81	----	Yes
13	DPB1013A	14	8.638	18.880	3.852	0.0	0.999	30.94	12.62	2.771	Yes
14	DPB1014A	15	8.638	18.880	3.852	0.0	1.114	31.90	13.79	3.008	Yes

**DAMAGE STABILITY SUMMARY
 175' FERRY**

Ca	No.	FILE NAME	DAMAGED COMP. LISTING	---Intact Condition---			-----Equilibrium Condition After Damage-----					
				MN.DRAFT (ft)	VCG (ft)	GMt (ft)	HEEL (deg)	MAX.GZ (ft)	RANGE (deg)	AREA (ft-deg)	DAM.GMT (ft)	SURVIVAL
	1	RTB1001A	1	8.366	19.280	3.733	0.0	1.207	33.26	15.09	3.753	Yes
	2	RTB1002A	1,2	8.366	19.280	3.733	0.0	1.002	29.82	13.79	3.501	Yes
	3	RTB1003A	2	8.366	19.280	3.733	0.0	1.066	31.36	14.19	3.516	Yes
	4	RTB1004A	3	8.366	19.280	3.733	0.0	0.939	30.69	12.69	3.226	Yes
	5	RTB1005A	4	8.366	19.280	3.733	0.0	0.818	29.24	11.28	3.008	Yes
	6	RTB1006A	4,5	8.366	19.280	3.733	0.2S	0.811	28.87	11.09	----	Yes
	7	RTB1007A	7	8.366	19.280	3.733	0.0	0.951	30.26	12.83	3.240	Yes
	8	RTB1008A	8	8.366	19.280	3.733	0.0	0.934	30.12	12.43	3.078	Yes
	9	RTB1009A	9,8	8.366	19.280	3.733	0.0	0.947	30.06	12.61	3.122	Yes
	10	RTB1010A	10	8.366	19.280	3.733	0.0	0.876	29.21	11.75	2.729	Yes
	11	RTB1011A	11	8.366	19.280	3.733	0.0	0.925	30.76	11.37	2.585	Yes
	12	RTB1012A	11,12	8.366	19.280	3.733	1.0S	0.916	29.61	10.89	----	Yes
	13	RTB1013A	14	8.366	19.280	3.733	0.0	1.003	31.10	12.13	2.647	Yes
	14	RTB1014A	15	8.366	19.280	3.733	0.0	1.093	31.91	13.28	2.887	Yes

HYDROSTATIC TABLES
 175' FERRY

MOLDED DRAFT (ft)		5.000	6.000	7.000	7.520	7.750	7.780
DISP. MLD. (LTons-SW)		278.9	385.1	504.7	572.0	602.8	606.8
DISP. TOTAL (LTons-SW)		279.7	386.3	506.3	573.7	604.6	608.7
DISP. TOTAL (LTons-FW)		272.9	376.9	493.9	559.7	589.8	593.8
LCB (ft-FP)		87.298A	88.353A	89.877A	90.768A	91.168A	91.220A
LCB (forebody) (ft-FP)		62.990A	61.797A	60.851A	60.429A	60.253A	60.231A
LCB (aftbody) (ft-FP)		110.748A	112.949A	115.487A	116.868A	117.475A	117.554A
TCB (ft-CL)		0.000	0.000	0.000	0.000	0.000	0.000
KB (ft)		3.260	3.880	4.502	4.826	4.969	4.988
BMT (ft)		25.285	22.456	20.000	18.988	18.676	18.645
KMT (ft)		28.545	26.335	24.502	23.813	23.645	23.633
BMI (ft)		396.663	397.734	394.296	393.882	392.201	391.967
KMI (ft)		399.922	401.614	398.798	398.707	397.170	396.955
TRF (LTons)		8.24	9.43	10.50	11.04	11.27	11.30
(ft-LTons)		52.7	72.9	94.8	107.3	112.6	113.3
(LTons)		0.07	0.30	0.54	0.68	0.74	0.75
LCF (ft-FP)		88.991A	93.019A	96.519A	98.283A	98.949A	99.033A
M.P. AREA (ft2)		3,462.7	3,962.7	4,409.2	4,639.0	4,736.1	4,748.8
WETTED SUR. (ft2)		4,339.4	5,017.4	5,651.1	5,983.9	6,128.3	6,147.2
MAX. BEAM (ft)		33.229	33.962	34.695	35.076	35.245	35.267
LENGTH W.L. (ft)		158.968	159.700	170.362	173.896	174.064	174.086
Cb		0.2861	0.3292	0.3698	0.3901	0.3989	0.4001
Cb (forebody)		0.2809	0.3166	0.3467	0.3608	0.3668	0.3676
Cb (aftbody)		0.2912	0.3419	0.3930	0.4194	0.4311	0.4326
Cm		0.6263	0.6633	0.6925	0.7056	0.7111	0.7118
Cp		0.4567	0.4964	0.5341	0.5529	0.5610	0.5620
Cup		0.5074	0.5806	0.6460	0.6797	0.6939	0.6958
Cit		0.2853	0.3500	0.4085	0.4395	0.4555	0.4579

Assumes: Sea Water at 35.0063 ft3/LT
 Fresh Water at 35.8814 ft3/LT
 Ship floating at even keel (no heel or trim)

**DAMAGE STABILITY SUMMARY
 175' FERRY**

CASE No.	FILE NAME	DAMAGED COMP. LISTING	---Intact Condition---			-----Equilibrium Condition After Damage-----					
			MIN.DRAFT (ft)	VCG (ft)	GMT (ft)	HEEL (deg)	MAX.GZ (ft)	RANGE (deg)	AREA (ft-deg)	DAM.GMT (ft)	SURVIVAL
1	HULL001A	1	8.383	18.810	4.184	0.0	1.386	34.89	17.16	4.213	Yes
2	HULL002A	1,2	8.383	18.810	4.184	0.0	1.174	31.62	16.00	4.001	Yes
3	HULL003A	2	8.383	18.810	4.184	0.0	1.243	33.05	16.34	4.099	Yes
4	HULL004A	3	8.383	18.810	4.184	0.0	1.105	32.39	14.81	3.796	Yes
5	HULL005A	4	8.383	18.810	4.184	0.0	0.975	30.96	13.35	3.498	No *F
6	HULL006A	4,5	8.383	18.810	4.184	0.5P	0.944	30.27	12.65	----	No *F
7	HULL007A	7	8.383	18.810	4.184	0.0	1.107	31.86	14.84	3.713	Yes
8	HULL008A	8	8.383	18.810	4.184	0.0	1.089	31.69	14.43	3.520	Yes
9	HULL009A	9,8	8.383	18.810	4.184	0.0	1.141	31.95	15.16	3.686	Yes
10	HULL010A	10	8.383	18.810	4.184	0.0	1.015	30.68	13.64	3.176	No *F
11	HULL011A	11	8.383	18.810	4.184	0.0	1.081	32.28	13.33	3.022	Yes
12	HULL012A	11,12	8.383	18.810	4.184	0.8P	1.000	30.76	11.97	----	No *F
13	HULL013A	14	8.383	18.810	4.184	0.0	1.155	32.56	14.05	3.087	Yes
14	HULL014A	15	8.383	18.810	4.184	0.0	1.256	33.40	15.20	3.330	Yes

*F WARNING: The required GMT for non-survival cases does not meet all survival criteria.

HULL001A:
 175' FERRY

Damaged Compartments:

FOREPEAK

	DISPLACEMENT LTons	DRAFT AFT ft	DRAFT FWD ft	TRIM ft	HEEL deg.	UPRIGHT GMt ft
INTACT	691.4	8.333	8.433	0.100F	0.00	4.184
DAMAGED	700.3	8.162	8.803	0.640F	0.00	4.213

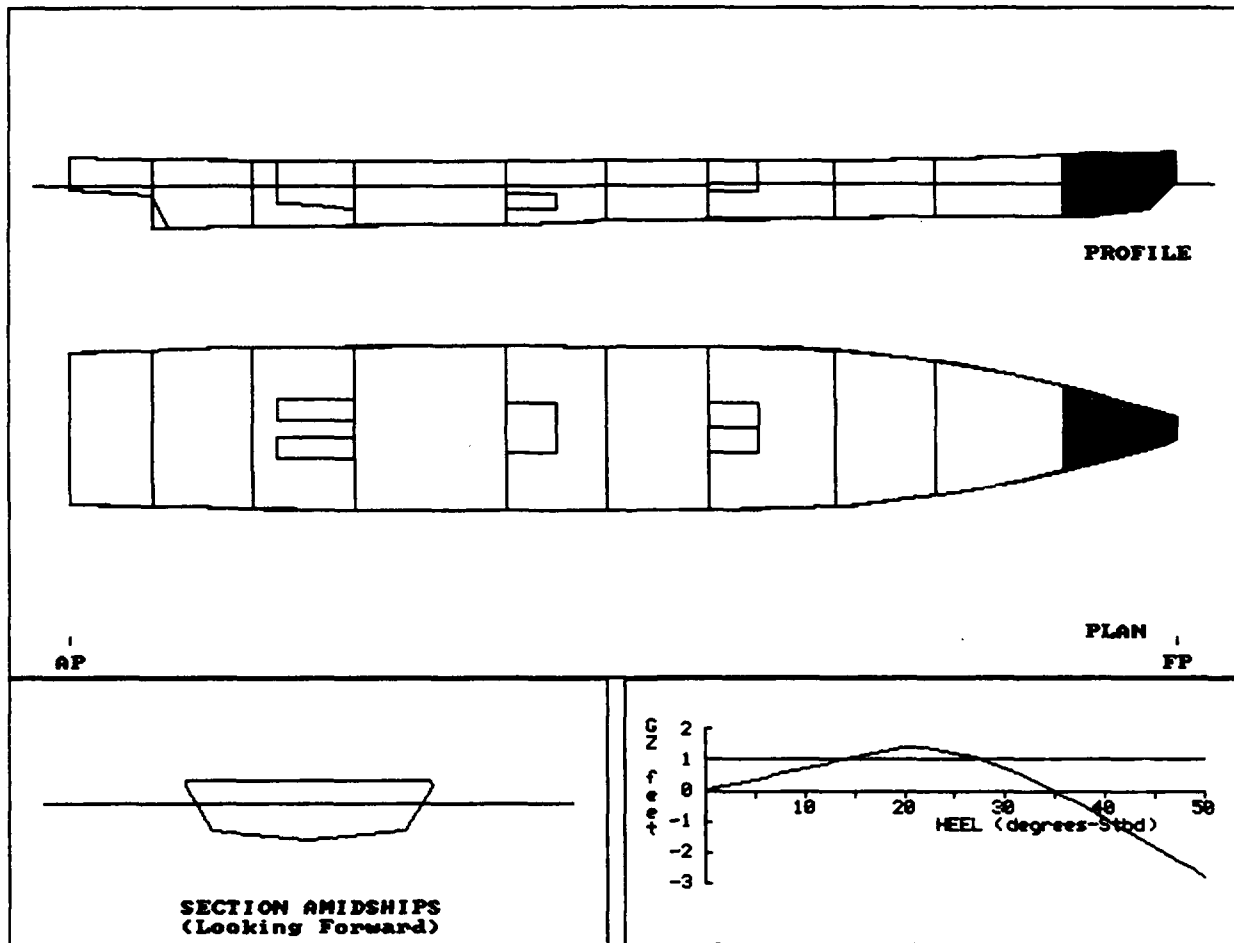

HULL001A:
 175' FERRY

COMPARTMENT FLOODING SUMMARY

At 0.0o Heel	PERM.	FLOODED WTR LTons	% FULL (Damaged)	% FULL (Intact)	SP.VOL. ft3/LT	OUTFLOW LTons
FOREPEAK	0.95	8.8	FREE	0.0	----	----
Totals		8.8				

INTACT DATA

Draft at AP = 8.333 ft	KMt = 22.994 ft	LCG = 91.998A ft-FP
Draft at FP = 8.433 ft	VCG = 18.810 ft	LCB = 91.990A ft-FP
Displacement = 691.4 LTons	Gmt = 4.184 ft	TCG = 0.000 ft-CL

DRAFT/GZ DATA

HEEL degrees	RIGHTING ARM ft	DRAFT AFT ft	DRAFT FWD ft	FLOODED WATER LTons
0.00	0.000	8.162	8.803	8.8
5.00S	0.363	8.105	8.784	8.8
7.00S	0.506	8.041	8.779	8.8
10.00S	0.722	7.911	8.754	8.8
15.00S	1.087	7.530	8.739	8.8
20.00S	1.376	6.981	8.719	8.9
30.00S	0.717	5.610	8.877	9.8
40.00S	-0.887	4.003	9.159	12.2
50.00S	-2.794	1.967	9.623	15.4

Note: Drafts are measured at A.P. and F.P along ship's centerline

GZ SUMMARY (Evaluated per IMO (SOLAS'90) Rules for Passenger Ships)

	Available	Required
Static Heel Angle	0.00 deg	7.00 deg
Angle at Maximum GZ	22.00S deg	
Maximum GZ	1.386 ft	1.020 ft
Range of Positive GZ	34.89 deg	15.00 deg
Gmt (upright damaged)	4.213 ft	
Righting Area (0.00-%.00)	17.164 ft-deg	2.820 ft-deg

**HULL002A:
 175' FERRY**

Imaged Compartments:

FOREPEAK BOW THRUSTER

	DISPLACEMENT LTons	DRAFT AFT ft	DRAFT FWD ft	TRIM ft	HEEL deg.	UPRIGHT GMt ft
INTACT	691.4	8.333	8.433	0.100F	0.00	4.184
DAMAGED	763.8	7.237	10.951	3.714F	0.00	4.001

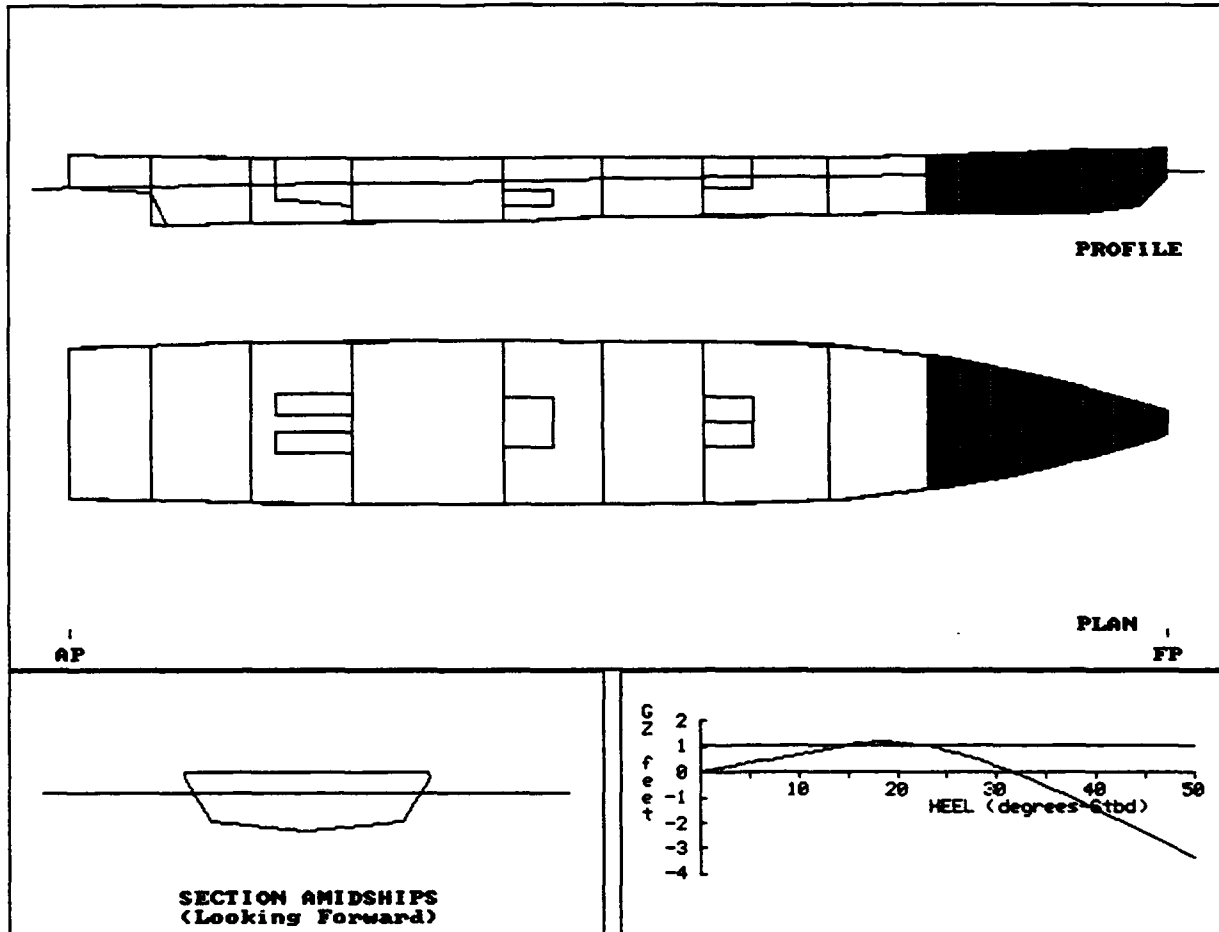

**HULL002A:
 175' FERRY**

COMPARTMENT FLOODING SUMMARY

At 0.0o Heel	PERM.	FLOODED WTR LTons	% FULL (Damaged)	% FULL (Intact)	SP.VOL. ft3/LT	OUTFLOW LTons
FOREPEAK	0.95	15.0	FREE	0.0	----	----
BOW THRUSTER	0.95	57.4	FREE	0.0	----	----
Totals		72.4				

INTACT DATA

Draft at AP = 8.333 ft	KMt = 22.994 ft	LCG = 91.998A ft-FP
Draft at FP = 8.433 ft	VCG = 18.810 ft	LCB = 91.990A ft-FP
Displacement = 691.4 LTons	GMt = 4.184 ft	TCG = 0.000 ft-CL

DRAFT/GZ DATA

HEEL degrees	RIGHTING ARM ft	DRAFT AFT ft	DRAFT FWD ft	FLOODED WATER LTons
0.00	0.000	7.237	10.951	72.4
5.00S	0.354	7.141	10.974	72.9
7.00S	0.498	7.062	10.981	73.2
10.00S	0.712	6.887	11.001	74.0
15.00S	1.063	6.454	11.050	76.1
20.00S	1.163	5.769	11.369	82.0
30.00S	0.241	3.708	13.141	101.8
40.00S	-1.440	1.048	15.745	117.2
50.00S	-3.342	-2.394	19.315	126.9

Note: Drafts are measured at A.P. and F.P along ship's centerline

GZ SUMMARY (Evaluated per IMO (SOLAS'90) Rules for Passenger Ships)

	Available	Required
Static Heel Angle	0.00 deg	7.00 deg
Angle at Maximum GZ	20.00S deg	
Maximum GZ	1.174 ft	1.020 ft
Range of Positive GZ	31.62 deg	15.00 deg
Gmt (upright damaged)	4.001 ft	
Righting Area (0.00-%.00)	15.997 ft-deg	2.820 ft-deg

HULL003A:
 175' FERRY

Damaged Compartments:

BOW THRUSTER

	DISPLACEMENT LTons	DRAFT AFT ft	DRAFT FWD ft	TRIM ft	HEEL deg.	UPRIGHT GMt ft
INTACT	691.4	8.333	8.433	0.100F	0.00	4.184
DAMAGED	742.5	7.620	10.160	2.539F	0.00	4.099

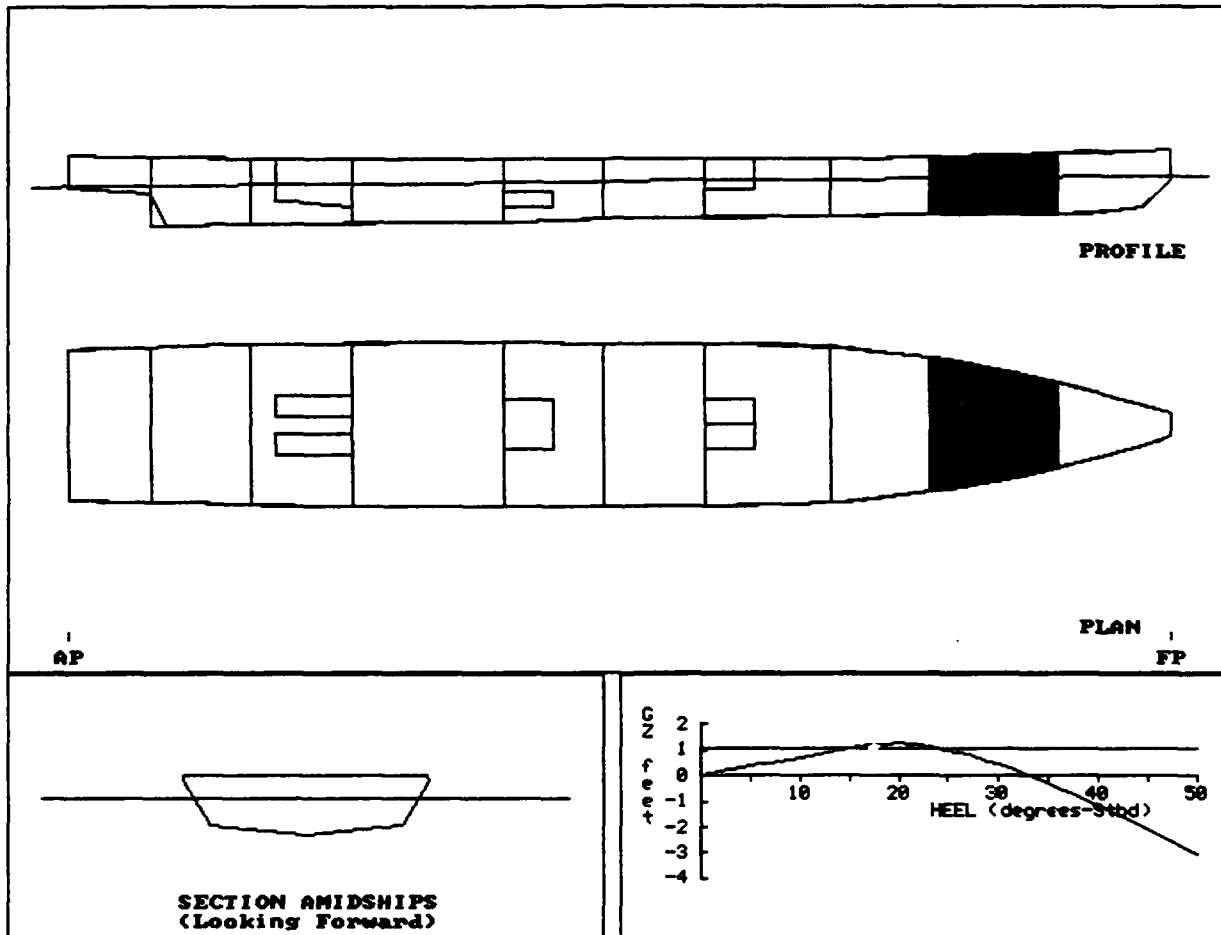

**HULL003A:
 175' FERRY**

COMPARTMENT FLOODING SUMMARY

At 0.0o Heel	PERM.	FLOODED WTR LTons	% FULL (Damaged)	% FULL (Intact)	SP.VOL. ft3/LT	OUTFLOW LTons
BOW THRUSTER	0.95	51.1	FREE	0.0	----	----
Totals		51.1				

INTACT DATA

Draft at AP = 8.333 ft	KMt = 22.994 ft	LCG = 91.998A ft-FP
Draft at FP = 8.433 ft	VCG = 18.810 ft	LCB = 91.990A ft-FP
Displacement = 691.4 LTons	Gmt = 4.184 ft	TCG = 0.000 ft-CL

DRAFT/GZ DATA

HEEL degrees	RIGHTING ARM ft	DRAFT AFT ft	DRAFT FWD ft	FLOODED WATER LTons
0.00	0.000	7.620	10.160	51.1
5.00S	0.354	7.539	10.167	51.3
7.00S	0.496	7.463	10.173	51.6
10.00S	0.709	7.305	10.177	52.0
15.00S	1.064	6.911	10.177	53.2
20.00S	1.243	6.306	10.321	56.3
30.00S	0.440	4.622	11.269	65.5
40.00S	-1.170	2.702	12.362	70.1
50.00S	-3.041	0.340	13.753	72.7

Note: Drafts are measured at A.P. and F.P along ship's centerline

GZ SUMMARY (Evaluated per IMO (SOLAS'90) Rules for Passenger Ships)

	Available	Required
Static Heel Angle	0.00 deg	7.00 deg
Angle at Maximum GZ	21.00S deg	
Maximum GZ	1.243 ft	1.020 ft
Range of Positive GZ	33.05 deg	15.00 deg
Gmt (upright damaged)	4.099 ft	
Righting Area (0.00-%.00)	16.340 ft-deg	2.820 ft-deg

HULL004A:
 175' FERRY

Damaged Compartments:

VOID 1

	DISPLACEMENT LTons	DRAFT AFT ft	DRAFT FWD ft	TRIM ft	HEEL deg.	UPRIGHT GMt ft
INTACT	691.4	8.333	8.433	0.100F	0.00	4.184
DAMAGED	766.4	7.687	10.450	2.762F	0.00	3.796

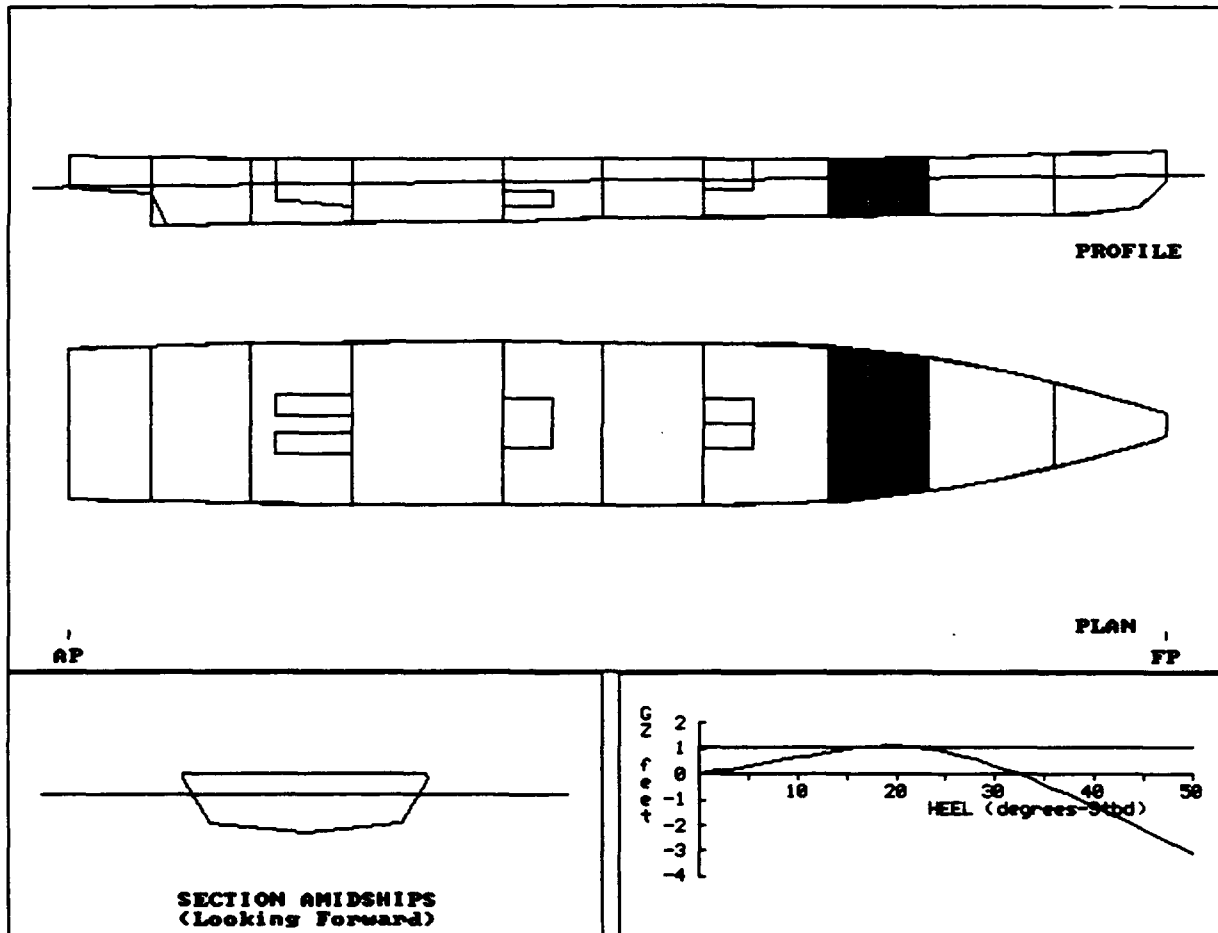

**HULL004A:
 175' FERRY**

COMPARTMENT FLOODING SUMMARY

At 0.0o Heel	PERM.	FLOODED WTR LTons	% FULL (Damaged)	% FULL (Intact)	SP.VOL. ft3/LT	OUTFLOW LTons
VOID 1	0.95	75.0	FREE	0.0	----	----
Totals		75.0				

INTACT DATA

Draft at AP = 8.333 ft	KMt = 22.994 ft	LCG = 91.998A ft-FP
Draft at FP = 8.433 ft	VCG = 18.810 ft	LCB = 91.990A ft-FP
Displacement = 691.4 LTons	GMt = 4.184 ft	TCG = 0.000 ft-CL

DRAFT/GZ DATA

HEEL degrees	RIGHTING ARM ft	DRAFT AFT ft	DRAFT FWD ft	FLOODED WATER LTons
0.00	0.000	7.687	10.450	75.0
5.00S	0.325	7.611	10.453	75.3
7.00S	0.456	7.538	10.456	75.6
10.00S	0.650	7.387	10.456	76.2
15.00S	0.970	7.005	10.451	77.6
20.00S	1.105	6.448	10.562	79.4
30.00S	0.332	5.013	11.208	80.8
40.00S	-1.257	3.374	11.988	80.6
50.00S	-3.107	1.357	12.995	79.9

Note: Drafts are measured at A.P. and F.P along ship's centerline

GZ SUMMARY (Evaluated per IMO (SOLAS'90) Rules for Passenger Ships)

	Available	Required
Static Heel Angle	0.00 deg	7.00 deg
Angle at Maximum GZ	21.00S deg	
Maximum GZ	1.105 ft	1.020 ft
Range of Positive GZ	32.39 deg	15.00 deg
Gmt (upright damaged)	3.796 ft	
Righting Area (0.00-%.00)	14.805 ft-deg	2.820 ft-deg

HULL005A:
 175' FERRY

Damaged Compartments:

VOID 2

	DISPLACEMENT LTons	DRAFT AFT ft	DRAFT FWD ft	TRIM ft	HEEL deg.	UPRIGHT GMT ft
INTACT	691.4	8.333	8.433	0.100F	0.00	4.184
DAMAGED	816.0	7.938	10.902	2.964F	0.00	3.498

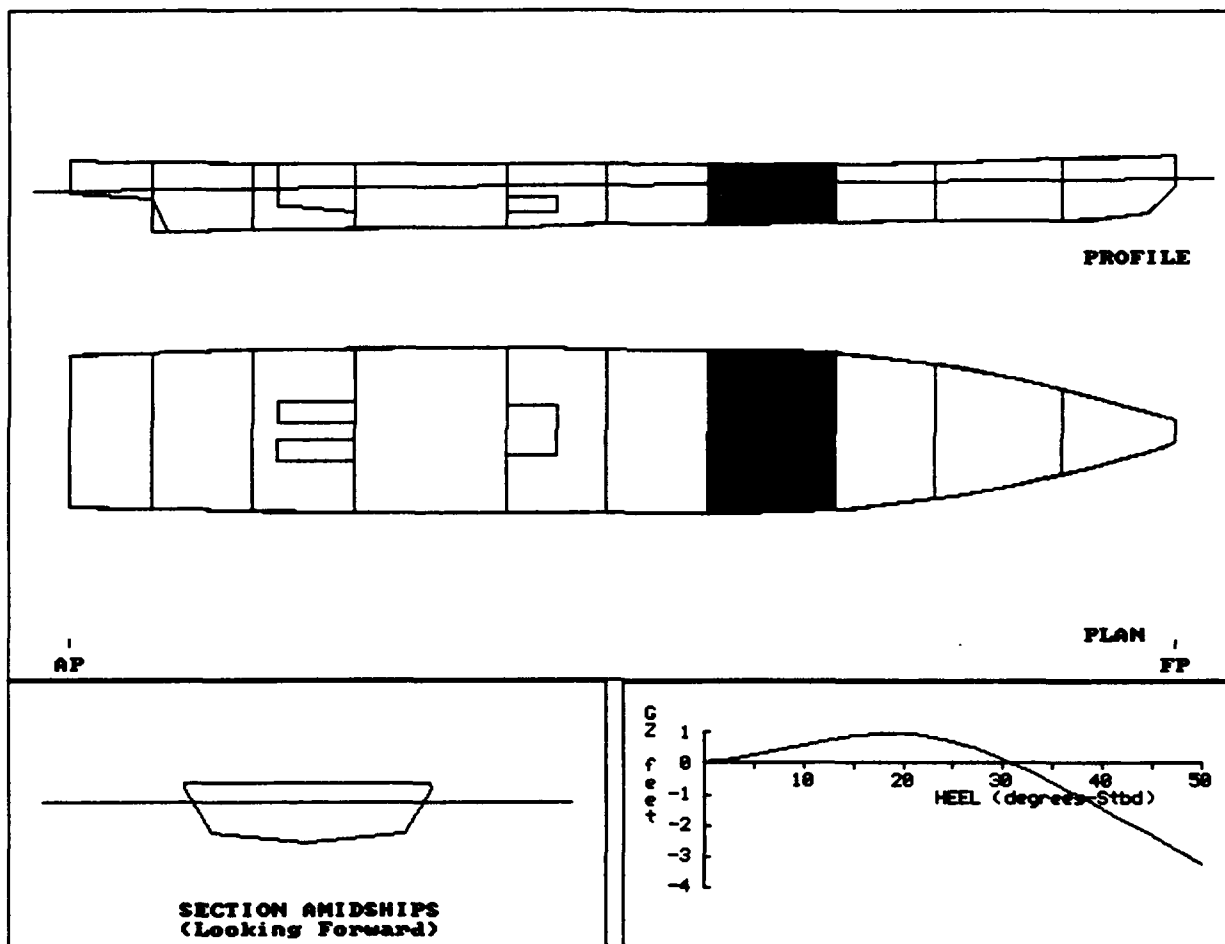

HULL005A:
 175' FERRY

COMPARTMENT FLOODING SUMMARY

At 0.0o Heel	PERM.	FLOODED WTR LTons	% FULL (Damaged)	% FULL (Intact)	SP.VOL. ft3/LT	OUTFLOW LTons
VOID 2	0.95	124.5	FREE	0.0	----	----
Totals		124.5				

INTACT DATA

Draft at AP = 8.333 ft	KMt = 22.994 ft	LCG = 91.998A ft-FP
Draft at FP = 8.433 ft	VCG = 18.810 ft	LCB = 91.990A ft-FP
Displacement = 691.4 LTons	Gmt = 4.184 ft	TCG = 0.000 ft-CL

DRAFT/GZ DATA

HEEL degrees	RIGHTING ARM ft	DRAFT AFT ft	DRAFT FWD ft	FLOODED WATER LTons
0.00	0.000	7.938	10.902	124.5
5.00S	0.298	7.876	10.891	124.7
7.00S	0.416	7.812	10.885	125.0
10.00S	0.597	7.678	10.868	125.5
15.00S	0.887	7.331	10.831	126.2
20.00S	0.964	6.840	10.917	125.1
30.00S	0.131	5.636	11.485	120.8
40.00S	-1.453	4.273	12.205	116.5
50.00S	-3.272	2.567	13.170	112.9

Note: Drafts are measured at A.P. and F.P along ship's centerline

GZ SUMMARY (Evaluated per IMO (SOLAS'90) Rules for Passenger Ships)

	Available	Required
Static Heel Angle	0.00 deg	7.00 deg
Angle at Maximum GZ	20.00S deg	
*** Maximum GZ	0.975 ft	1.020 ft
Range of Positive GZ	30.96 deg	15.00 deg
Gmt (upright damaged)	3.498 ft	
Righting Area (0.00-%.00)	13.346 ft-deg	2.820 ft-deg

*** indicates failure to meet criterion

**HULL006A:
 175' FERRY**

amaged Compartments:

VOID 2 FRESH H2O ST

	DISPLACEMENT LTons	DRAFT AFT ft	DRAFT FWD ft	TRIM ft	HEEL deg.	UPRIGHT GMT ft
INTACT	691.4	8.333	8.433	0.100F	0.00	4.184
DAMAGED	808.5	7.943	10.775	2.832F	0.45P	3.475

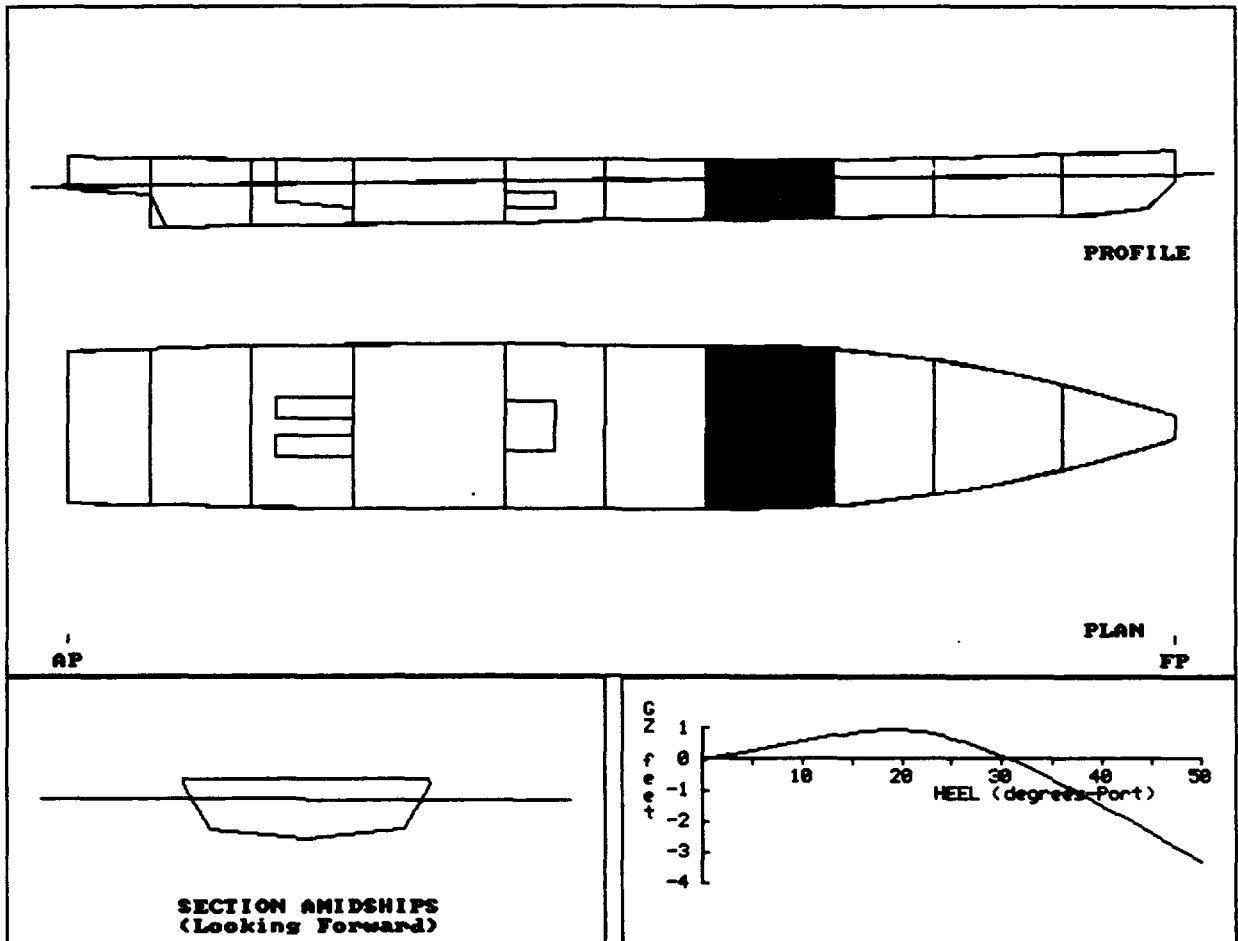

**HULL006A:
 175' FERRY**

COMPARTMENT FLOODING SUMMARY

At 0.50P Heel	PERM.	FLOODED WTR LTons	% FULL (Damaged)	% FULL (Intact)	SP.VOL. ft3/LT	OUTFLOW LTons
VOID 2	0.95	123.3	FREE	0.0	----	----
FRESH H2O ST	0.95	3.7	FREE	100.0	34.2000	9.9
Totals		127.0				9.9

INTACT DATA

Draft at AP = 8.333 ft	Kmt = 22.994 ft	LCG = 91.998A ft-FP
Draft at FP = 8.433 ft	VCG = 18.810 ft	LCB = 91.990A ft-FP
Displacement = 691.4 LTons	GMT = 4.184 ft	TCG = 0.000 ft-CL

DRAFT/GZ DATA

HEEL degrees	RIGHTING ARM ft	DRAFT AFT ft	DRAFT FWD ft	FLOODED WATER LTons
0.00	-0.027	7.948	10.777	127.1
5.00P	0.269	7.886	10.759	126.8
7.00P	0.385	7.822	10.750	126.8
10.00P	0.563	7.689	10.727	127.0
15.00P	0.850	7.343	10.676	127.1
20.00P	0.935	6.848	10.738	125.5
30.00P	0.099	5.630	11.243	120.3
40.00P	-1.501	4.253	11.879	115.7
50.00P	-3.335	2.536	12.721	111.9

Note: Drafts are measured at A.P. and F.P along ship's centerline

GZ SUMMARY (Evaluated per IMO (SOLAS'90) Rules for Passenger Ships)

	Available	Required
Static Heel Angle	0.45P deg	7.00 deg
Angle at Maximum GZ	20.00P deg	
*** Maximum GZ	0.944 ft	1.020 ft
Range of Positive GZ	30.27 deg	15.00 deg
Righting Area (0.45-%.00)	12.651 ft-deg	2.820 ft-deg

*** indicates failure to meet criterion

**HULL007A:
 175' FERRY**

Damaged Compartments:

CREW QUARTER

	DISPLACEMENT LTons	DRAFT AFT ft	DRAFT FWD ft	TRIM ft	HEEL deg.	UPRIGHT GMt ft
INTACT	691.4	8.333	8.433	0.100F	0.00	4.184
DAMAGED	805.2	8.563	9.952	1.389F	0.00	3.713

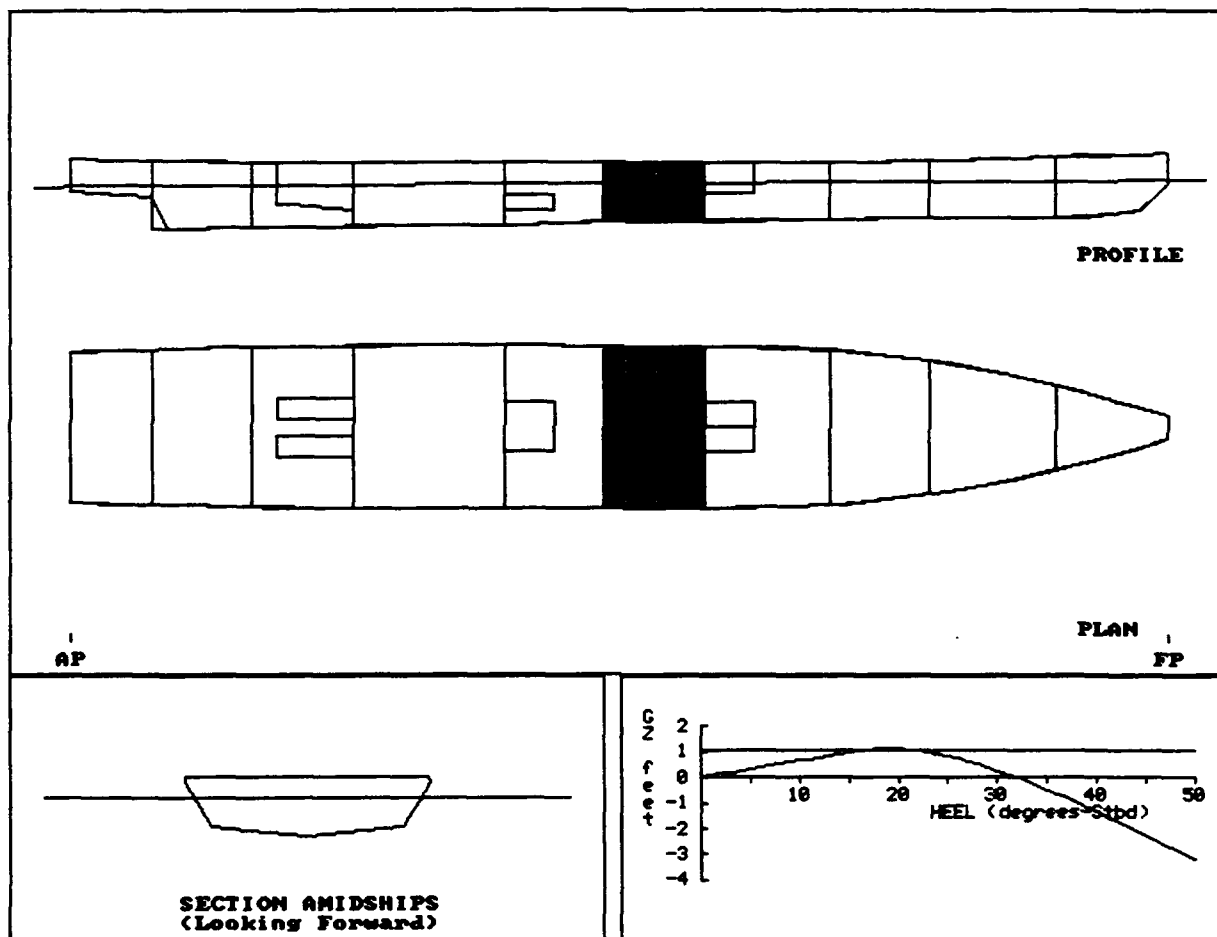

**HULL007A:
 175' FERRY**

COMPARTMENT FLOODING SUMMARY

At 0.0o Heel	PERM.	FLOODED WTR LTons	% FULL (Damaged)	% FULL (Intact)	SP.VOL. ft3/LT	OUTFLOW LTons
CREW QUARTER	0.95	113.7	FREE	0.0	----	----
Totals		113.7				

INTACT DATA

Draft at AP = 8.333 ft	KMt = 22.994 ft	LCG = 91.998A ft-FP
Draft at FP = 8.433 ft	VCG = 18.810 ft	LCB = 91.990A ft-FP
Displacement = 691.4 LTons	GMt = 4.184 ft	TCG = 0.000 ft-CL

DRAFT/GZ DATA

HEEL degrees	RIGHTING ARM ft	DRAFT AFT ft	DRAFT FWD ft	FLOODED WATER LTons
0.00	0.000	8.563	9.952	113.7
5.00S	0.324	8.518	9.924	113.6
7.00S	0.453	8.467	9.907	113.5
10.00S	0.651	8.356	9.864	113.3
15.00S	0.979	8.024	9.802	112.6
20.00S	1.104	7.573	9.808	110.6
30.00S	0.263	6.599	10.063	105.1
40.00S	-1.344	5.539	10.394	101.3
50.00S	-3.188	4.214	10.852	98.6

Note: Drafts are measured at A.P. and F.P along ship's centerline

GZ SUMMARY (Evaluated per IMO (SOLAS'90) Rules for Passenger Ships)

	Available	Required
Static Heel Angle	0.00 deg	7.00 deg
Angle at Maximum GZ	20.00S deg	
Maximum GZ	1.107 ft	1.020 ft
Range of Positive GZ	31.86 deg	15.00 deg
Gmt (upright damaged)	3.713 ft	
Righting Area (0.00 % .00)	14.841 ft-deg	2.820 ft-deg

**HULL008A:
 175' FERRY**

Imaged Compartments:
 STORE ROOM

	DISPLACEMENT LTons	DRAFT AFT ft	DRAFT FWD ft	TRIM ft	HEEL deg.	UPRIGHT GMt ft
INTACT	691.4	8.333	8.433	0.100F	0.00	4.184
DAMAGED	794.4	8.994	9.224	0.229F	0.00	3.520

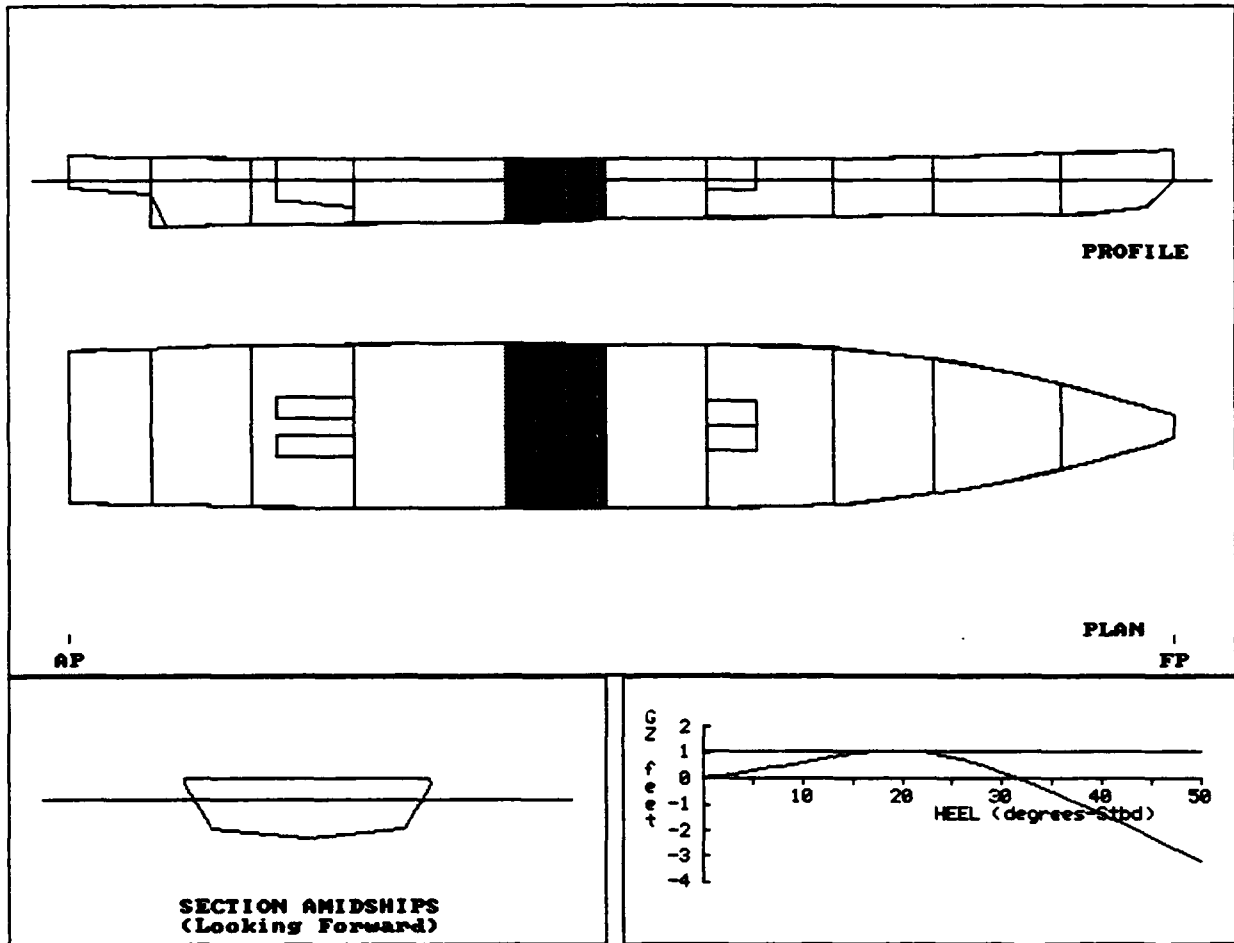

**HULL008A:
 175' FERRY**

COMPARTMENT FLOODING SUMMARY

At 0.0o Heel	PERM.	FLOODED WTR LTons	% FULL (Damaged)	% FULL (Intact)	SP.VOL. ft3/LT	OUTFLOW LTons
STORE ROOM	0.95	102.9	FREE	0.0	----	----
Totals		102.9				

INTACT DATA

Draft at AP = 8.333 ft	KMt = 22.994 ft	LCG = 91.998A ft-FP
Draft at FP = 8.433 ft	VCG = 18.810 ft	LCB = 91.990A ft-FP
Displacement = 691.4 LTons	GMt = 4.184 ft	TCG = 0.000 ft-CL

DRAFT/GZ DATA

HEEL degrees	RIGHTING ARM ft	DRAFT AFT ft	DRAFT FWD ft	FLOODED WATER LTons
0.00	0.000	8.994	9.224	102.9
5.00S	0.309	8.962	9.186	102.8
7.00S	0.434	8.917	9.164	102.7
10.00S	0.627	8.819	9.112	102.3
15.00S	0.951	8.496	9.047	101.1
20.00S	1.088	8.068	9.011	98.5
30.00S	0.240	7.240	9.090	93.5
40.00S	-1.364	6.396	9.189	91.3
50.00S	-3.206	5.355	9.345	90.1

Note: Drafts are measured at A.P. and F.P along ship's centerline

GZ SUMMARY (Evaluated per IMO (SOLAS'90) Rules for Passenger Ships)

	Available	Required
Static Heel Angle	0.00 deg	7.00 deg
Angle at Maximum GZ	20.00S deg	
Maximum GZ	1.089 ft	1.020 ft
Range of Positive GZ	31.69 deg	15.00 deg
Gmt (upright damaged)	3.520 ft	
Righting Area (0.00-%.00)	14.427 ft-deg	2.820 ft-deg

HULL009A:
 175' FERRY

Imaged Compartments:

SEWAGE TANK STORE ROOM

	DISPLACEMENT LTons	DRAFT AFT ft	DRAFT FWD ft	TRIM ft	HEEL deg.	UPRIGHT GMt ft
INTACT	691.4	8.333	8.433	0.100F	0.00	4.184
DAMAGED	804.2	9.068	9.282	0.214F	0.00	3.686

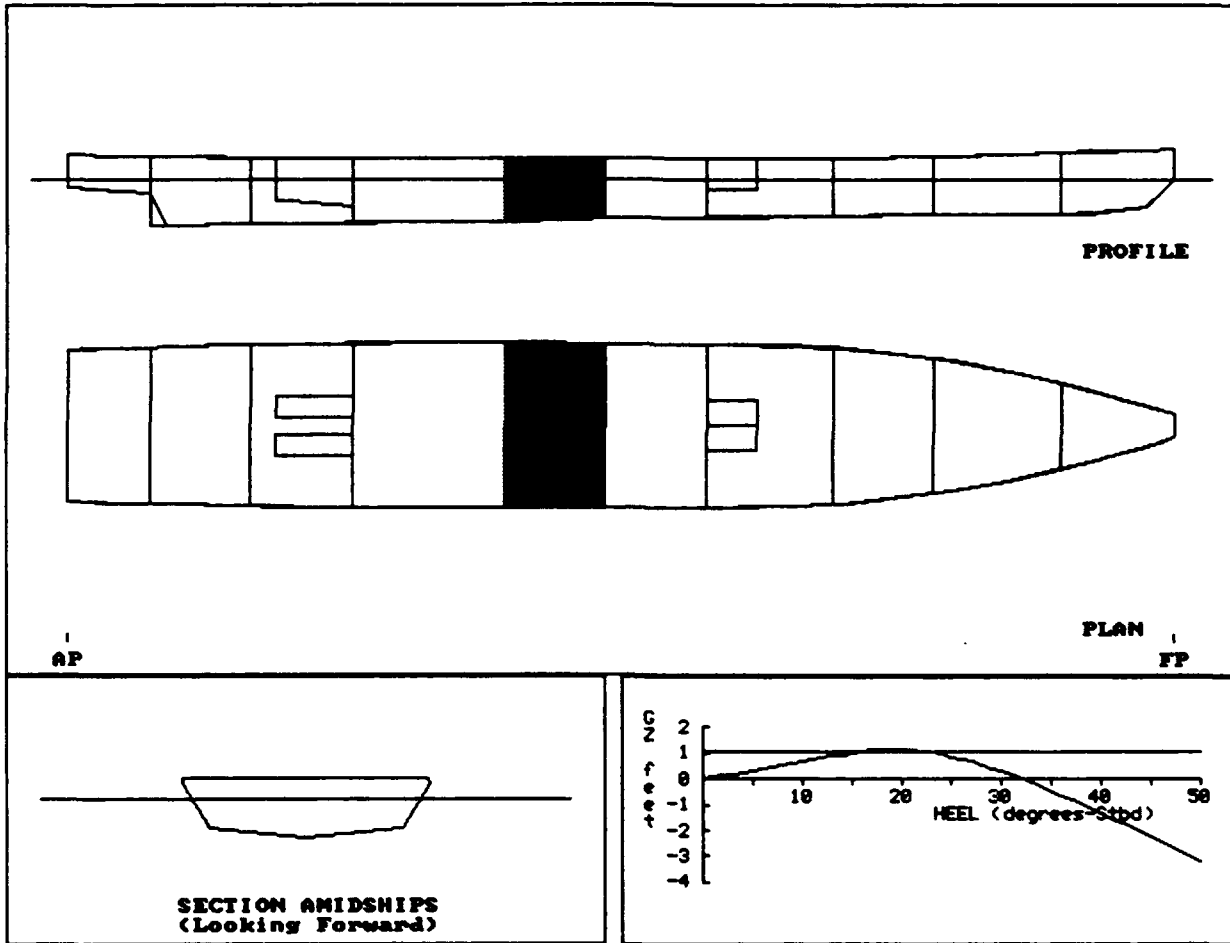

**HULL009A:
 175' FERRY**

COMPARTMENT FLOODING SUMMARY

At 0.0o Heel	PERM.	FLOODED WTR LTons	% FULL (Damaged)	% FULL (Intact)	SP.VOL. ft3/LT	OUTFLOW LTons
SEWAGE TANK	0.95	9.8	FREE	10.0	35.0063	1.0
STORE ROOM	0.95	104.0	FREE	0.0	----	----
Totals		113.8				1.0

INTACT DATA

Draft at AP	= 8.333 ft	KMt	= 22.994 ft	LCG	= 91.998A ft-FP
Draft at FP	= 8.433 ft	VCG	= 18.810 ft	LCB	= 91.990A ft-FP
Displacement	= 691.4 LTons	GMT	= 4.184 ft	TCG	= 0.000 ft-CL

DRAFT/GZ DATA

HEEL degrees	RIGHTING ARM ft	DRAFT AFT ft	DRAFT FWD ft	FLOODED WATER LTons
0.00	0.000	9.068	9.282	113.8
5.00S	0.325	9.038	9.244	113.6
7.00S	0.457	8.994	9.221	113.5
10.00S	0.660	8.898	9.166	113.1
15.00S	1.002	8.582	9.098	112.0
20.00S	1.138	8.171	9.063	109.4
30.00S	0.281	7.391	9.143	103.6
40.00S	-1.336	6.581	9.241	99.9
50.00S	-3.190	5.570	9.396	97.3

Note: Drafts are measured at A.P. and F.P along ship's centerline

GZ SUMMARY (Evaluated per IMO (SOLAS'90) Rules for Passenger Ships)

	Available	Required
Static Heel Angle	0.00 deg	7.00 deg
Angle at Maximum GZ	20.00S deg	
Maximum GZ	1.141 ft	1.020 ft
Range of Positive GZ	31.95 deg	15.00 deg
Gmt (upright damaged)	3.686 ft	
Righting Area (0.00-%.00)	15.161 ft-deg	2.820 ft-deg

HULL010A:
 175' FERRY

Damaged Compartments:
 ENGINE ROOM

	DISPLACEMENT LTons	DRAFT AFT ft	DRAFT FWD ft	TRIM ft	HEEL deg.	UPRIGHT GMt ft
INTACT	691.4	8.333	8.433	0.100F	0.00	4.184
DAMAGED	831.4	10.022	8.452	1.570A	0.00	3.176

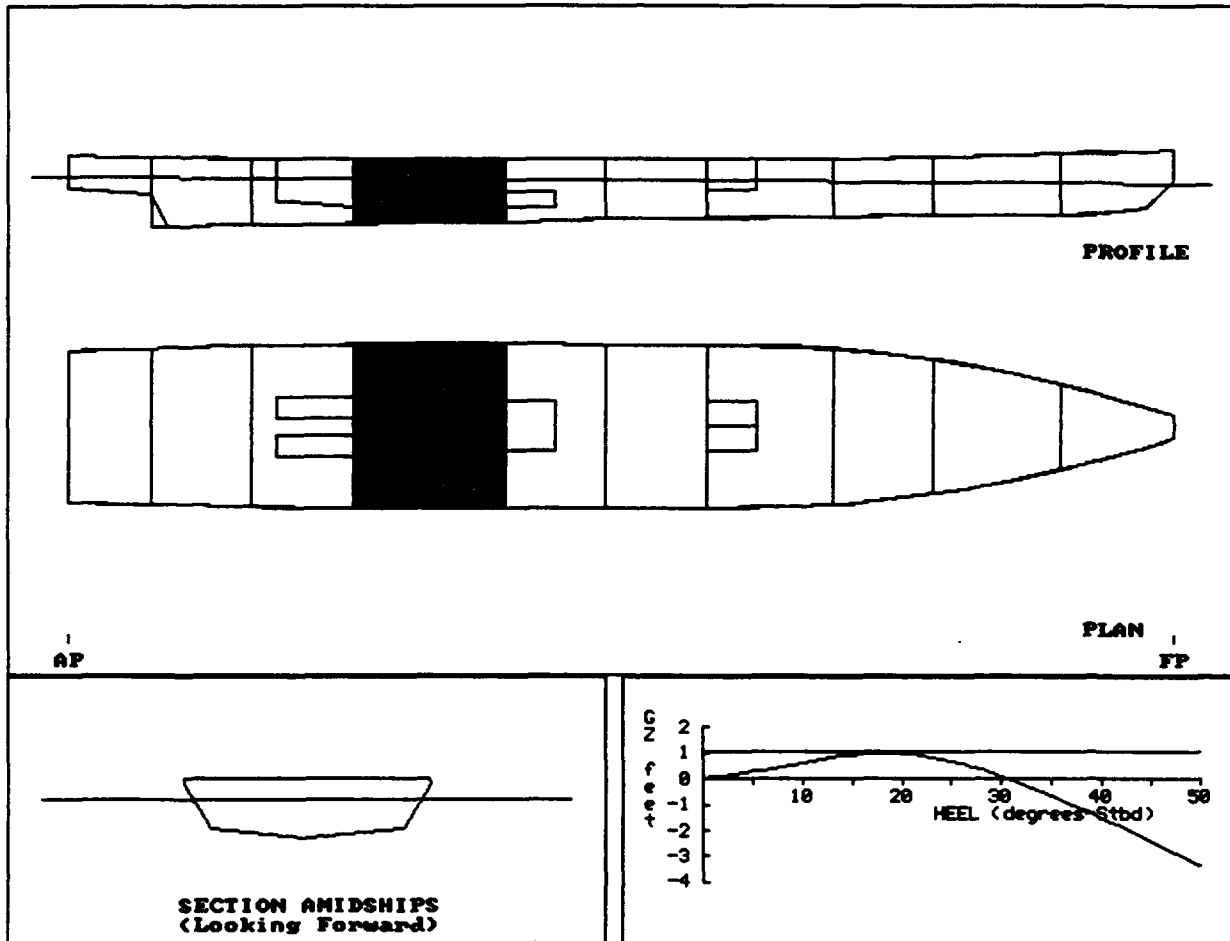

HULL010A:
 175' FERRY

COMPARTMENT FLOODING SUMMARY

At 0.0o Heel	PERM.	FLOODED WTR LTons	% FULL (Damaged)	% FULL (Intact)	SP.VOL. ft3/LT	OUTFLOW LTons
ENGINE ROOM	0.85	139.9	FREE	0.0	----	----
Totals		139.9				

INTACT DATA

Draft at AP = 8.333 ft	KMt = 22.994 ft	LCG = 91.998A ft-FP
Draft at FP = 8.433 ft	VCG = 18.810 ft	LCB = 91.990A ft-FP
Displacement = 691.4 LTons	Gmt = 4.184 ft	TCG = 0.000 ft-CL

DRAFT/GZ DATA

HEEL degrees	RIGHTING ARM ft	DRAFT AFT ft	DRAFT FWD ft	FLOODED WATER LTons
0.00	0.000	10.022	8.452	139.9
5.00S	0.284	9.998	8.407	139.9
7.00S	0.406	9.963	8.379	139.7
10.00S	0.599	9.868	8.338	139.3
15.00S	0.930	9.614	8.227	137.7
20.00S	0.998	9.349	8.120	133.9
30.00S	0.096	9.071	7.949	128.8
40.00S	-1.515	8.895	7.728	126.1
50.00S	-3.345	8.748	7.442	124.2

Note: Drafts are measured at A.P. and F.P along ship's centerline

GZ SUMMARY (Evaluated per IMO (SOLAS'90) Rules for Passenger Ships)

	Available	Required
Static Heel Angle	0.00 deg	7.00 deg
Angle at Maximum GZ	19.00S deg	
*** Maximum GZ	1.015 ft	1.020 ft
Range of Positive GZ	30.68 deg	15.00 deg
Gmt (upright damaged)	3.176 ft	
Righting Area (0.00-%.00)	13.644 ft-deg	2.820 ft-deg

*** indicates failure to meet criterion

HULL011A:
 175' FERRY

Damaged Compartments:

VOID 3

	DISPLACEMENT LTons	DRAFT AFT ft	DRAFT FWD ft	TRIM ft	HEEL deg.	UPRIGHT GMt ft
INTACT	691.4	8.333	8.433	0.100F	0.00	4.184
DAMAGED	747.2	9.353	7.985	1.367A	0.00	3.022

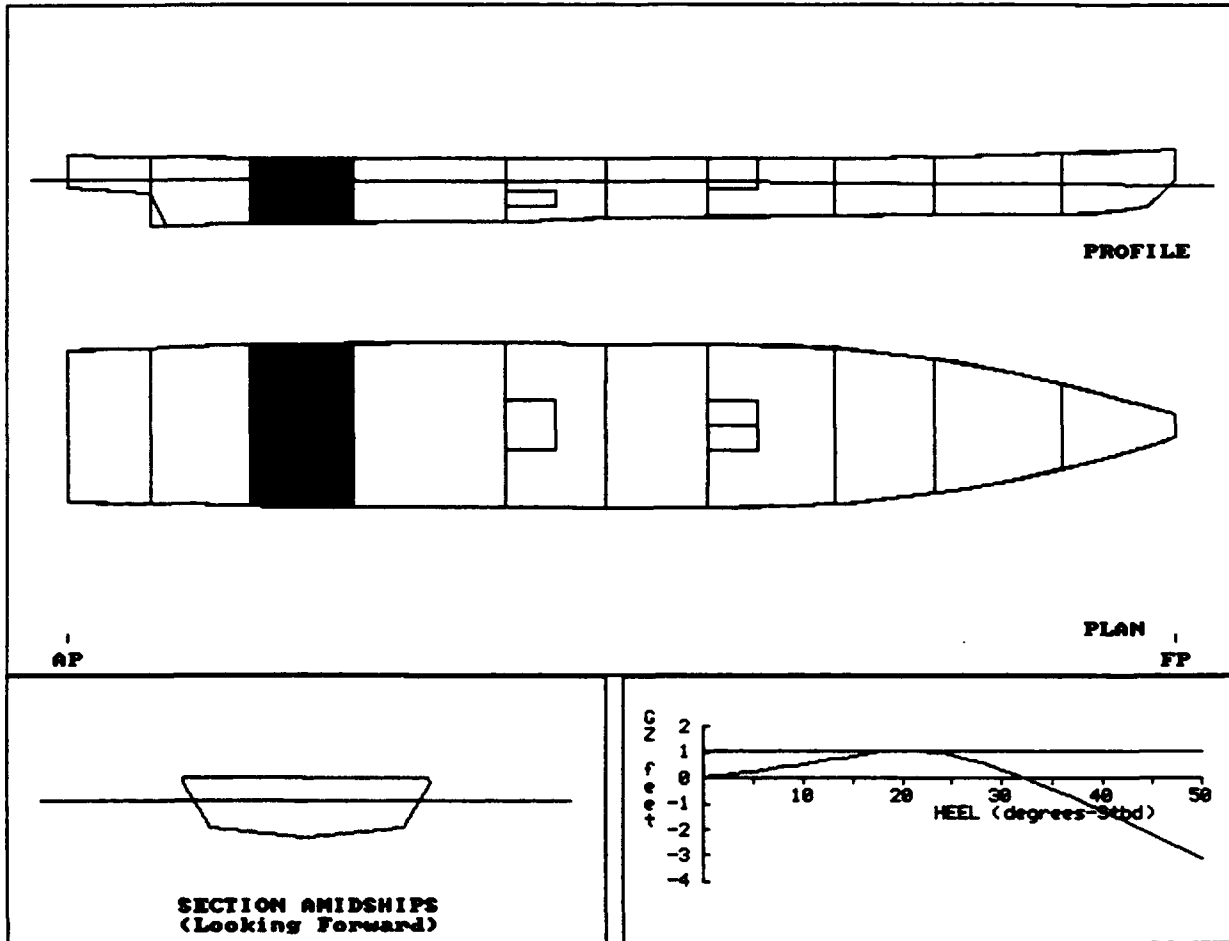

**HULL011A:
 175' FERRY**

COMPARTMENT FLOODING SUMMARY

At 0.0o Heel	PERM.	FLOODED WTR LTons	% FULL (Damaged)	% FULL (Intact)	SP.VOL. ft3/LT	OUTFLOW LTons
VOID 3	0.95	55.7	FREE	0.0	----	----
Totals		55.7				

INTACT DATA

Draft at AP = 8.333 ft	KMt = 22.994 ft	LCG = 91.998A ft-FP
Draft at FP = 8.433 ft	VCG = 18.810 ft	LCB = 91.990A ft-FP
Displacement = 691.4 LTons	Gmt = 4.184 ft	TCG = 0.000 ft-CL

DRAFT/GZ DATA

HEEL degrees	RIGHTING ARM ft	DRAFT AFT ft	DRAFT FWD ft	FLOODED WATER LTons
0.00	0.000	9.353	7.985	55.7
5.00S	0.269	9.330	7.943	55.9
7.00S	0.381	9.292	7.920	55.9
10.00S	0.553	9.181	7.896	55.7
15.00S	0.858	8.887	7.821	55.5
20.00S	1.081	8.510	7.734	56.2
30.00S	0.322	7.926	7.501	58.4
40.00S	-1.268	7.362	7.177	59.4
50.00S	-3.124	6.617	6.774	59.0

Note: Drafts are measured at A.P. and F.P along ship's centerline

GZ SUMMARY (Evaluated per IMO (SOLAS'90) Rules for Passenger Ships)

	Available	Required
Static Heel Angle	0.00 deg	7.00 deg
Angle at Maximum GZ	21.00S deg	
Maximum GZ	1.081 ft	1.020 ft
Range of Positive GZ	32.28 deg	15.00 deg
Gmt (upright damaged)	3.022 ft	
Righting Area (0.00-%.00)	13.334 ft-deg	2.820 ft-deg

HULL012A:
 175' FERRY

Damaged Compartments:

VOID 3 FO TANK STBD

	DISPLACEMENT LTons	DRAFT AFT ft	DRAFT FWD ft	TRIM ft	HEEL deg.	UPRIGHT GMT ft
INTACT	691.4	8.333	8.433	0.100F	0.00	4.184
DAMAGED	739.6	9.218	8.033	1.185A	0.80P	2.990

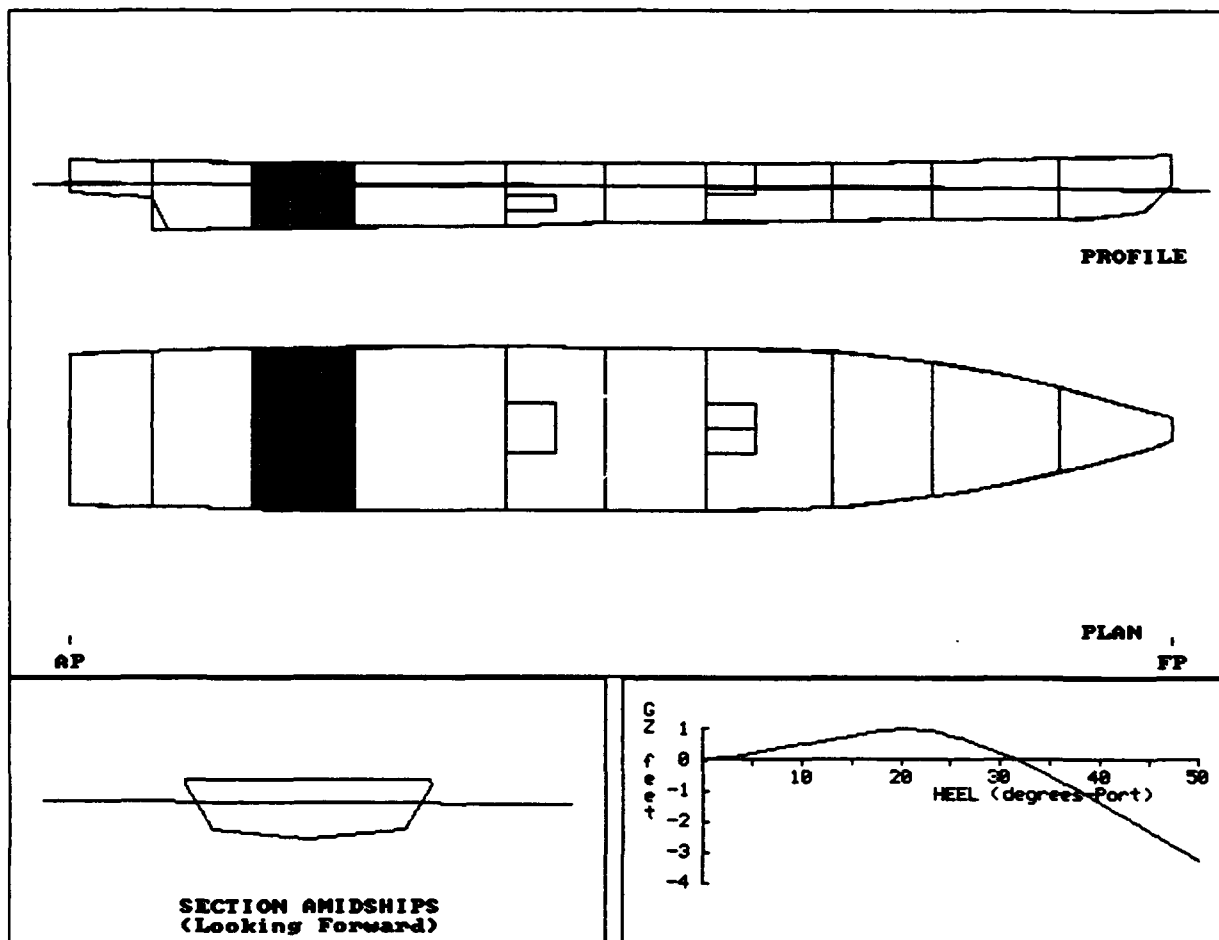

HULL012A:
 175' FERRY

COMPARTMENT FLOODING SUMMARY

At 0.80P Heel	PERM.	FLOODED WTR LTons	% FULL (Damaged)	% FULL (Intact)	SP.VOL. ft3/LT	OUTFLOW LTons
VOID 3	0.95	54.6	FREE	0.0	----	----
FO TANK STBD	0.95	8.2	FREE	100.0	40.6000	14.6
Totals		62.8				14.6

INTACT DATA

Draft at AP = 8.333 ft	KMt = 22.994 ft	LCG = 91.998A ft-FP
Draft at FP = 8.433 ft	VCG = 18.810 ft	LCB = 91.990A ft-FP
Displacement = 691.4 LTons	GMt = 4.184 ft	TCG = 0.000 ft-CL

DRAFT/GZ DATA

HEEL degrees	RIGHTING ARM ft	DRAFT AFT ft	DRAFT FWD ft	FLOODED WATER LTons
0.00	-0.042	9.222	8.039	62.9
5.00P	0.222	9.186	8.002	62.2
7.00P	0.330	9.136	7.985	61.8
10.00P	0.494	9.007	7.970	61.0
15.00P	0.781	8.676	7.914	59.4
20.00P	1.000	8.237	7.851	58.9
30.00P	0.222	7.428	7.699	58.5
40.00P	-1.400	6.587	7.470	58.0
50.00P	-3.282	5.514	7.175	57.2

Note: Drafts are measured at A.P. and F.P along ship's centerline

GZ SUMMARY (Evaluated per IMO (SOLAS'90) Rules for Passenger Ships)

	Available	Required
Static Heel Angle	0.80P deg	7.00 deg
Angle at Maximum GZ	21.00P deg	
*** Maximum GZ	1.000 ft	1.020 ft
Range of Positive GZ	30.76 deg	15.00 deg
Righting Area (0.80-%.00)	11.968 ft-deg	2.820 ft-deg

*** indicates failure to meet criterion

HULL013A:
 175' FERRY

Damaged Compartments:

VOID 4

	DISPLACEMENT LTons	DRAFT AFT ft	DRAFT FWD ft	TRIM ft	HEEL deg.	UPRIGHT GMt ft
INTACT	691.4	8.333	8.433	0.100F	0.00	4.184
DAMAGED	740.4	9.449	7.743	1.706A	0.00	3.087

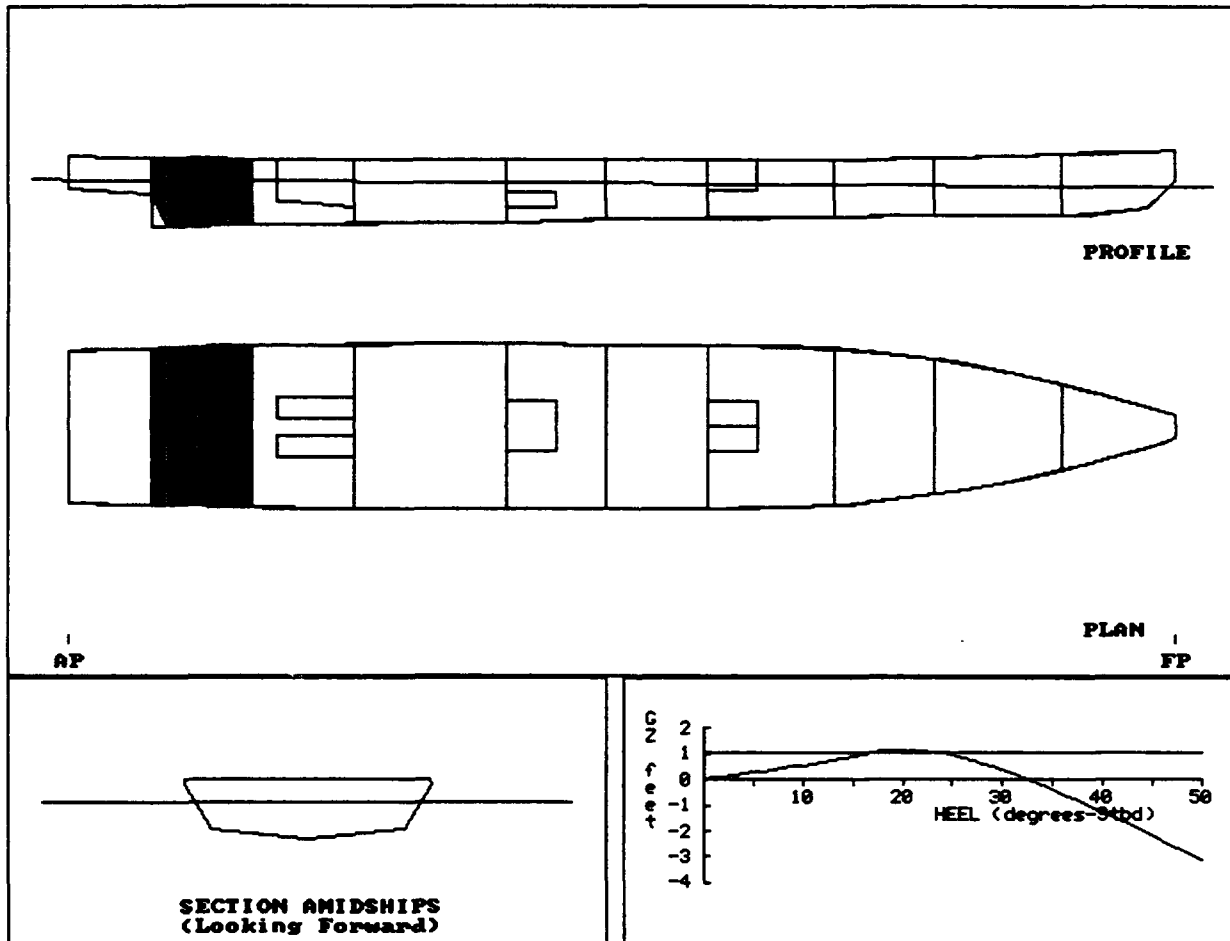

**HULL013A:
 175' FERRY**

COMPARTMENT FLOODING SUMMARY

At 0.0o Heel	PERM.	FLOODED WTR LTons	% FULL (Damaged)	% FULL (Intact)	SP.VOL. ft3/LT	OUTFLOW LTons
VOID 4	0.95	48.9	FREE	0.0	----	----
Totals		48.9				

INTACT DATA

Draft at AP = 8.333 ft	KMt = 22.994 ft	LCG = 91.998A ft-FP
Draft at FP = 8.433 ft	VCG = 18.810 ft	LCB = 91.990A ft-FP
Displacement = 691.4 LTons	GMt = 4.184 ft	TCG = 0.000 ft-CL

DRAFT/GZ DATA

HEEL degrees	RIGHTING ARM ft	DRAFT AFT ft	DRAFT FWD ft	FLOODED WATER LTons
0.00	0.000	9.449	7.743	48.9
5.00S	0.275	9.428	7.700	49.1
7.00S	0.390	9.389	7.677	49.0
10.00S	0.569	9.275	7.656	48.7
15.00S	0.912	9.010	7.565	49.5
20.00S	1.155	8.682	7.440	51.4
30.00S	0.371	8.237	7.076	54.9
40.00S	-1.248	7.875	6.576	57.3
50.00S	-3.132	7.486	5.916	59.1

Note: Drafts are measured at A.P. and F.P along ship's centerline

GZ SUMMARY (Evaluated per IMO (SOLAS'90) Rules for Passenger Ships)

	Available	Required
Static Heel Angle	0.00 deg	7.00 deg
Angle at Maximum GZ	21.00S deg	
Maximum GZ	1.155 ft	1.020 ft
Range of Positive GZ	32.56 deg	15.00 deg
Gmt (upright damaged)	3.087 ft	
Righting Area (0.00-%.00)	14.053 ft-deg	2.820 ft-deg

HULL014A:
 175' FERRY

Damaged Compartments:

LAZARETTE

	DISPLACEMENT LTons	DRAFT AFT ft	DRAFT FWD ft	TRIM ft	HEEL deg.	UPRIGHT GMt ft
INTACT	691.4	8.333	8.433	0.100F	0.00	4.184
DAMAGED	704.5	8.690	8.174	0.516A	0.00	3.330

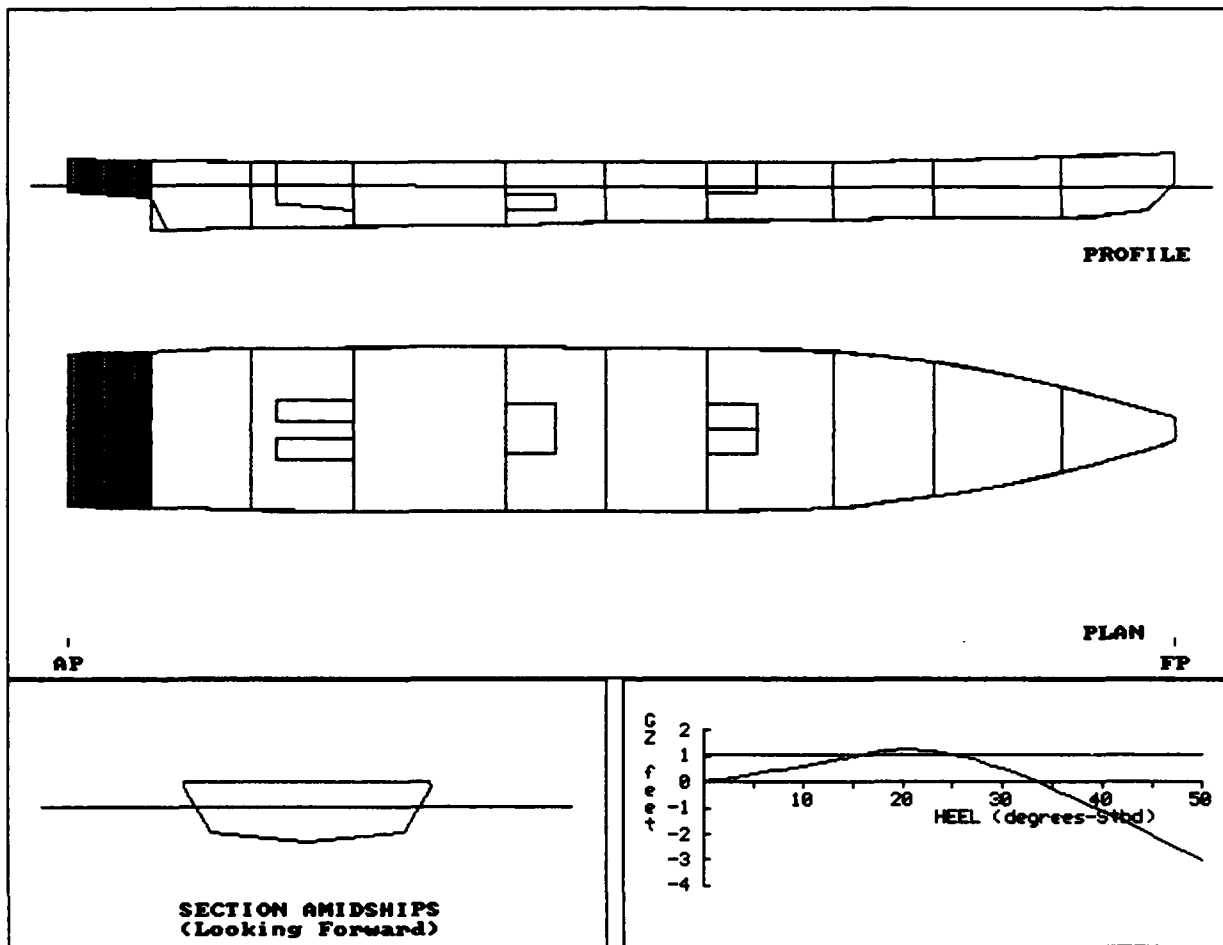

HULL014A:
 175' FERRY

COMPARTMENT FLOODING SUMMARY

At 0.0o Heel	PERM.	FLOODED WTR LTons	% FULL (Damaged)	% FULL (Intact)	SP.VOL. ft3/LT	OUTFLOW LTons
LAZARETTE	0.95	13.1	FREE	0.0	----	----
Totals		13.1				

INTACT DATA

Draft at AP = 8.333 ft	KMt = 22.994 ft	LCG = 91.998A ft-FP
Draft at FP = 8.433 ft	VCG = 18.810 ft	LCB = 91.990A ft-FP
Displacement = 691.4 LTons	GMT = 4.184 ft	TCG = 0.000 ft-CL

DRAFT/GZ DATA

HEEL degrees	RIGHTING ARM ft	DRAFT AFT ft	DRAFT FWD ft	FLOODED WATER LTons
0.00	0.000	8.690	8.174	13.1
5.00S	0.299	8.670	8.132	13.8
7.00S	0.425	8.638	8.103	14.4
10.00S	0.625	8.570	8.036	15.8
15.00S	0.975	8.285	7.962	17.8
20.00S	1.251	7.881	7.852	20.2
30.00S	0.500	7.155	7.557	25.4
40.00S	-1.127	6.441	7.157	28.8
50.00S	-3.031	5.583	6.627	31.2

Note: Drafts are measured at A.P. and F.P along ship's centerline

GZ SUMMARY (Evaluated per IMO (SOLAS'90) Rules for Passenger Ships)

	Available	Required
Static Heel Angle	0.00 deg	7.00 deg
Angle at Maximum GZ	22.00S deg	
Maximum GZ	1.256 ft	1.020 ft
Range of Positive GZ	33.40 deg	15.00 deg
Gmt (upright damaged)	3.330 ft	
Righting Area (0.00-%.00)	15.202 ft-deg	2.820 ft-deg

DPB1001A:
 175' FERRY

COMPARTMENT FLOODING SUMMARY

At 0.0o Heel	PERM.	FLOODED WTR LTons	% FULL (Damaged)	% FULL (Intact)	SP.VOL. ft3/LT	OUTFLOW LTons
FOREPEAK	0.95	9.7	FREE	0.0	----	----
Totals		9.7				

INTACT DATA

Draft at AP = 8.527 ft KMt = 22.732 ft LCG = 92.114A ft-FP
 Draft at FP = 8.749 ft VCG = 18.880 ft LCB = 92.097A ft-FP
 Displacement = 726.5 LTons GMT = 3.852 ft TCG = 0.000 ft-CL

DRAFT/GZ DATA

HEEL degrees	RIGHTING ARM ft	DRAFT AFT ft	DRAFT FWD ft	FLOODED WATER LTons
0.00	0.000	8.344	9.147	9.7
5.00S	0.338	8.294	9.122	9.7
7.00S	0.471	8.236	9.111	9.7
10.00S	0.676	8.116	9.078	9.6
15.00S	1.022	7.755	9.047	9.6
20.00S	1.258	7.242	9.039	9.7
30.00S	0.519	6.022	9.289	11.1
40.00S	-1.117	4.592	9.712	14.1
50.00S	-3.032	2.759	10.383	17.8

Note: Drafts are measured at A.P. and F.P along ship's centerline

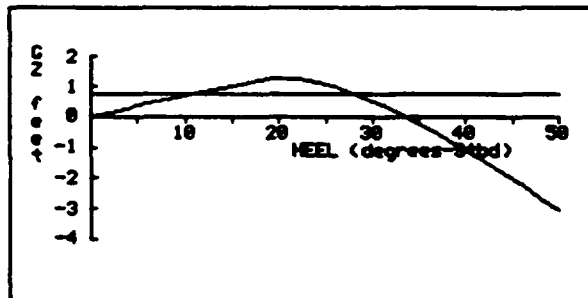

Static Heel = 0.0 deg
 Draft at AP = 8.344 ft
 Draft at FP = 9.147 ft

Get (upright damaged) = 3.875 ft
 Angle at Maximum GZ = 21.00S deg
 Maximum GZ = 1.258 ft
 Range of Positive GZ = 33.53 deg

Area to 22.0 degrees = 15.94 ft-deg

DPB1002A:
 175' FERRY

COMPARTMENT FLOODING SUMMARY

At 0.0o Heel	PERM.	FLOODED WTR LTons	% FULL (Damaged)	% FULL (Intact)	SP.VOL. ft3/LT	OUTFLOW LTons
FOREPEAK	0.95	16.6	FREE	0.0	----	----
BOW THRUSTER	0.95	62.0	FREE	0.0	----	----
Totals		78.6				

INTACT DATA

Draft at AP = 8.527 ft Kmt = 22.732 ft LCG = 92.114A ft-FP
 Draft at FP = 8.749 ft VCG = 18.880 ft LCB = 92.097A ft-FP
 Displacement = 726.5 LTons Gmt = 3.852 ft TCG = 0.000 ft-CL

DRAFT/GZ DATA

HEEL degrees	RIGHTING ARM ft	DRAFT AFT ft	DRAFT FWD ft	FLOODED WATER LTons
0.00	0.000	7.381	11.409	78.6
5.00S	0.334	7.291	11.426	79.1
7.00S	0.470	7.216	11.430	79.4
10.00S	0.675	7.049	11.442	80.2
15.00S	0.985	6.624	11.507	82.6
20.00S	0.995	5.959	11.918	89.5
30.00S	-0.020	3.950	13.944	110.1
40.00S	-1.725	1.364	16.895	124.9
50.00S	-3.626	-2.001	20.963	133.9

Note: Drafts are measured at A.P. and F.P along ship's centerline

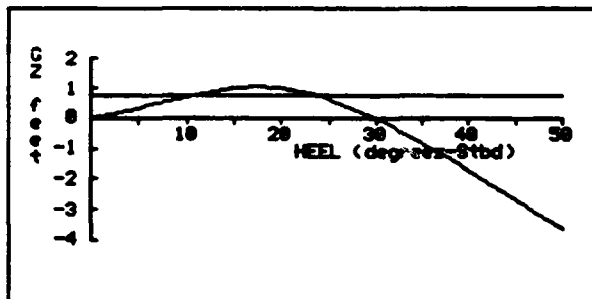

Static Heel = 0.0 deg
 Draft at AP = 7.381 ft
 Draft at FP = 11.409 ft

Gut (upright damaged) = 3.796 ft
 Angle at Maximum GZ = 19.885 deg
 Maximum GZ = 1.837 ft
 Range of Positive GZ = 29.86 deg

Area to 22.0 degrees = 14.56 ft-deg

DPB1003A:
 175' FERRY

COMPARTMENT FLOODING SUMMARY

At 0.0o Heel	PERM.	FLOODED WTR LTons	% FULL (Damaged)	% FULL (Intact)	SP.VOL. ft ³ /LT	OUTFLOW LTons
BOW THRUSTER	0.95	54.9	FREE	0.0	----	----
Totals		54.9				

INTACT DATA

Draft at AP = 8.527 ft KMt = 22.732 ft LCG = 92.114A ft-FP
 Draft at FP = 8.749 ft VCG = 18.880 ft LCB = 92.097A ft-FP
 Displacement = 726.5 LTons GMT = 3.852 ft TCG = 0.000 ft-CL

DRAFT/GZ DATA

HEEL degrees	RIGHTING ARM ft	DRAFT AFT ft	DRAFT FWD ft	FLOODED WATER LTons
0.00	0.000	7.787	10.557	54.9
5.00S	0.332	7.713	10.559	55.1
7.00S	0.466	7.642	10.560	55.3
10.00S	0.667	7.494	10.555	55.8
15.00S	0.999	7.118	10.546	57.0
20.00S	1.098	6.538	10.745	60.6
30.00S	0.222	4.990	11.803	69.7
40.00S	-1.410	3.239	13.060	74.1
50.00S	-3.284	1.058	14.731	76.8

Note: Drafts are measured at A.P. and F.P along ship's centerline

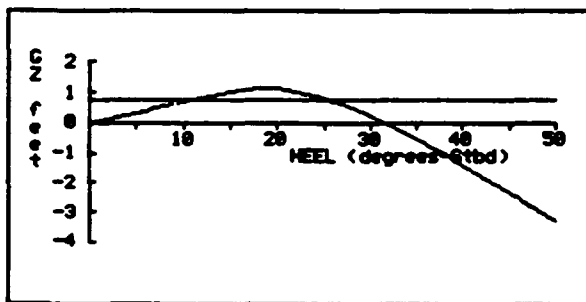

Static Heel = 0.0 deg
 Draft at AP = 7.787 ft
 Draft at FP = 10.557 ft

Gmt (upright damaged) = 3.898 ft
 Angle at Maximum GZ = 20.00S deg
 Maximum GZ = 1.167 ft
 Range of Positive GZ = 31.55 deg

Area to 22.0 degrees = 15.04 ft-deg

DPB1004A:
 175' FERRY

COMPARTMENT FLOODING SUMMARY

At 0.0o Heel	PERM.	FLOODED WTR LTons	% FULL (Damaged)	% FULL (Intact)	SP.VOL. ft3/LT	OUTFLOW LTons
VOID 1	0.95	79.1	FREE	0.0	----	----
Totals		79.1				

INTACT DATA

Draft at AP = 8.527 ft Kmt = 22.732 ft LCG = 92.114A ft-FP
 Draft at FP = 8.749 ft VCG = 18.880 ft LCB = 92.097A ft-FP
 Displacement = 726.5 LTons Gmt = 3.852 ft TCG = 0.000 ft-CL

DRAFT/GZ DATA

HEEL degrees	RIGHTING ARM ft	DRAFT AFT ft	DRAFT FWD ft	FLOODED WATER LTons
0.00	0.000	7.871	10.826	79.1
5.00S	0.305	7.802	10.822	79.4
7.00S	0.427	7.735	10.821	79.6
10.00S	0.612	7.594	10.812	80.2
15.00S	0.906	7.230	10.800	81.7
20.00S	0.970	6.710	10.945	83.2
30.00S	0.122	5.425	11.683	84.4
40.00S	-1.488	3.978	12.601	84.1
50.00S	-3.340	2.173	13.834	83.5

Note: Drafts are measured at A.P. and F.P along ship's centerline

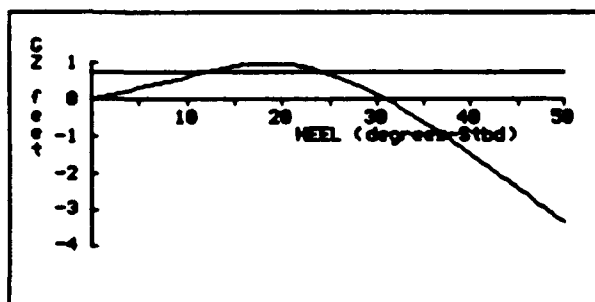

Static Heel = 0.0 deg
 Draft at AP = 7.871 ft
 Draft at FP = 10.826 ft

Gmt (upright damaged) = 3.579 ft
 Angle at Maximum GZ = 20.000 deg
 Maximum GZ = 0.984 ft
 Range of Positive GZ = 30.89 deg

Area to 22.0 degrees = 13.58 ft-deg

DPB1005A:
 175' FERRY

COMPARTMENT FLOODING SUMMARY

At 0.0o Heel	PERM.	FLOODED WTR LTons	% FULL (Damaged)	% FULL (Intact)	SP.VOL. ft3/LT	OUTFLOW LTons
VOID 2	0.95	129.4	FREE	0.0	----	----
Totals		129.4				

INTACT DATA

Draft at AP = 8.527 ft Kmt = 22.732 ft LCG = 92.114A ft-FP
 Draft at FP = 8.749 ft VCG = 18.880 ft LCB = 92.097A ft-FP
 Displacement = 726.5 LTons GMT = 3.852 ft TCG = 0.000 ft-CL

DRAFT/GZ DATA

HEEL degrees	RIGHTING ARM ft	DRAFT AFT ft	DRAFT FWD ft	FLOODED WATER LTons
0.00	0.000	8.138	11.259	129.4
5.00S	0.280	8.083	11.242	129.6
7.00S	0.391	8.024	11.232	129.9
10.00S	0.563	7.900	11.206	130.3
15.00S	0.823	7.571	11.170	130.7
20.00S	0.827	7.121	11.292	129.3
30.00S	-0.085	6.078	11.944	124.7
40.00S	-1.684	4.924	12.786	120.1
50.00S	-3.501	3.458	13.960	116.6

Note: Drafts are measured at A.P. and F.P along ship's centerline

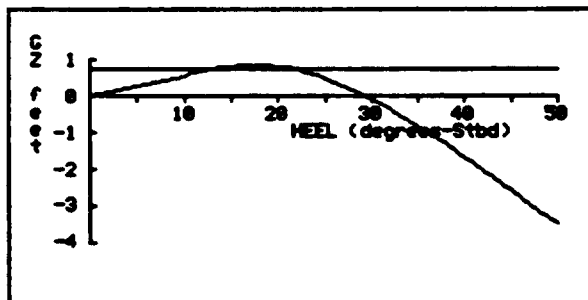

Static Heel = 0.0 deg
 Draft at AP = 8.138 ft
 Draft at FP = 11.259 ft

Gmt (upright damaged) = 3.225 ft
 Angle at Maximum GZ = 19.886 deg
 Maximum GZ = 0.865 ft
 Range of Positive GZ = 29.36 deg

Area to 22.8 degrees = 12.14 ft-deg

DPB1006A:
 175' FERRY

COMPARTMENT FLOODING SUMMARY

At 0.4oP Heel	PERM.	FLOODED WTR LTons	% FULL (Damaged)	% FULL (Intact)	SP.VOL. ft ³ /LT	OUTFLOW LTons
VOID 2	0.95	128.3	FREE	0.0	----	----
FRESH H2O ST	0.95	4.1	FREE	100.0	34.2000	9.9
Totals		132.4				9.9

INTACT DATA

Draft at AP = 8.527 ft Kmt = 22.732 ft LCG = 92.114A ft-FP
 Draft at FP = 8.749 ft VCG = 18.880 ft LCB = 92.097A ft-FP
 Displacement = 726.5 LTons Gmt = 3.852 ft TCG = 0.000 ft-CL

DRAFT/GS DATA

HEEL degrees	RIGHTING ARM ft	DRAFT AFT ft	DRAFT FWD ft	FLOODED WATER LTons
0.00	-0.024	8.146	11.144	132.5
5.00P	0.253	8.091	11.120	132.2
7.00P	0.363	8.033	11.107	132.2
10.00P	0.532	7.909	11.076	132.3
15.00P	0.792	7.581	11.025	132.1
20.00P	0.804	7.128	11.121	130.2
30.00P	-0.111	6.073	11.710	124.8
40.00P	-1.726	4.906	12.466	119.8
50.00P	-3.560	3.432	13.511	115.9

Note: Drafts are measured at A.P. and F.P along ship's centerline

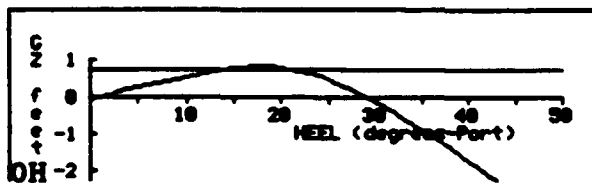

Static Heel = 0.4P deg
 Draft at AP = 8.143 ft
 Draft at FP = 11.142 ft

Angle at Maximum GZ = 19.00P deg
 Maximum GZ = 0.839 ft
 Values of Positive GZ = 22.74 deg.....

DPB1007A:
 175' FERRY

COMPARTMENT FLOODING SUMMARY

At 0.0o Heel	PERM.	FLOODED WTR LTons	% FULL (Damaged)	% FULL (Intact)	SP.VOL. ft3/LT	OUTFLOW LTons
CREW QUARTER	0.95	118.1	FREE	0.0	----	----
Totals		118.1				

INTACT DATA

Draft at AP = 8.527 ft KMt = 22.732 ft LCG = 92.114A ft-FP
 Draft at FP = 8.749 ft VCG = 18.880 ft LCB = 92.097A ft-FP
 Displacement = 726.5 LTons GMT = 3.852 ft TCG = 0.000 ft-CL

DRAFT/GZ DATA

HEEL degrees	RIGHTING ARM ft	DRAFT AFT ft	DRAFT FWD ft	FLOODED WATER LTons
0.00	0.000	8.771	10.293	118.1
5.00S	0.302	8.733	10.260	118.0
7.00S	0.424	8.686	10.239	117.9
10.00S	0.613	8.584	10.189	117.7
15.00S	0.920	8.272	10.121	116.9
20.00S	0.964	7.872	10.154	114.8
30.00S	0.042	7.085	10.474	109.2
40.00S	-1.582	6.259	10.906	105.4
50.00S	-3.420	5.233	11.508	102.6

Note: Drafts are measured at A.P. and F.P along ship's centerline

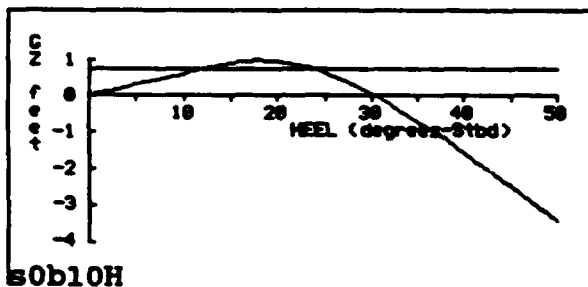

Static Heel = 0.0 deg
 Draft at AP = 8.771 ft
 Draft at FP = 10.293 ft

Gmt (upright damaged) = 3.456 ft
 Angle at Maximum GZ = 19.888 deg
 Maximum GZ = 0.998 ft
 Range of Positive GZ = 30.29 deg

Area to 22.8 degrees = 13.61 ft-deg

DPB1008A:
 175' FERRY

COMPARTMENT FLOODING SUMMARY

At 0.0o Heel	PERM.	FLOODED WTR LTons	% FULL (Damaged)	% FULL (Intact)	SP.VOL. ft3/LT	OUTFLOW LTons
STORE ROOM	0.95	107.2	FREE	0.0	----	----
Totals		107.2				

INTACT DATA

Draft at AP = 8.527 ft KMt = 22.732 ft LCG = 92.114A ft-FP
 Draft at FP = 8.749 ft VCG = 18.880 ft LCB = 92.097A ft-FP
 Displacement = 726.5 LTons GMT = 3.852 ft TCG = 0.000 ft-CL

DRAFT/GZ DATA

HEEL degrees	RIGHTING ARM ft	DRAFT AFT ft	DRAFT FWD ft	FLOODED WATER LTons
0.00	0.000	9.213	9.555	107.2
5.00S	0.285	9.185	9.514	107.0
7.00S	0.403	9.144	9.489	106.9
10.00S	0.586	9.053	9.430	106.6
15.00S	0.894	8.752	9.354	105.4
20.00S	0.949	8.386	9.333	102.8
30.00S	0.017	7.755	9.464	97.4
40.00S	-1.607	7.153	9.643	94.9
50.00S	-3.443	6.444	9.912	93.6

Note: Drafts are measured at A.P. and F.P along ship's centerline

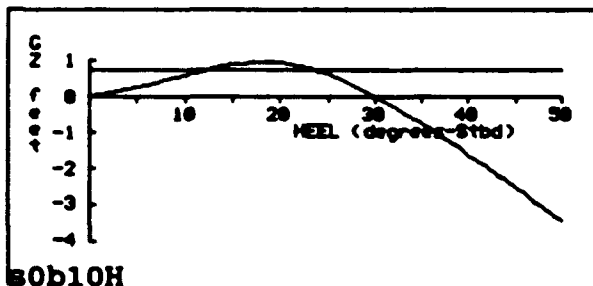

Static Heel = 0.0 deg
 Draft at AP = 9.213 ft
 Draft at FP = 9.555 ft

Gmt (upright damaged) = 3.223 ft
 Angle at Maximum GZ = 19.886 deg
 Maximum GZ = 0.971 ft
 Range of Positive GZ = 38.12 deg

Area to 22.0 degrees = 13.19 ft-deg

80b10H

DPB1009A:
 175' FERRY

COMPARTMENT FLOODING SUMMARY

At 0.0o Heel	PERM.	FLOODED WTR LTons	% FULL (Damaged)	% FULL (Intact)	SP.VOL. ft3/LT	OUTFLOW LTons
SEWAGE TANK	0.95	9.8	FREE	10.0	35.0063	1.0
STORE ROOM	0.95	108.2	FREE	0.0	----	----
Totals		118.0				1.0

INTACT DATA

Draft at AP = 8.527 ft Kmt = 22.732 ft LCG = 92.114A ft-FP
 Draft at FP = 8.749 ft VCG = 18.880 ft LCB = 92.097A ft-FP
 Displacement = 726.5 LTons Gmt = 3.852 ft TCG = 0.000 ft-CL

DRAFT/GZ DATA

HEEL degrees	RIGHTING ARM ft	DRAFT AFT ft	DRAFT FWD ft	FLOODED WATER LTons
0.00	0.000	9.288	9.612	118.0
5.00S	0.300	9.260	9.571	117.9
7.00S	0.425	9.220	9.544	117.7
10.00S	0.618	9.132	9.484	117.4
15.00S	0.941	8.837	9.406	116.3
20.00S	0.992	8.490	9.386	113.6
30.00S	0.052	7.914	9.519	107.8
40.00S	-1.581	7.356	9.699	104.1
50.00S	-3.426	6.686	9.969	101.5

Note: Drafts are measured at A.P. and F.P. along ship's centerline

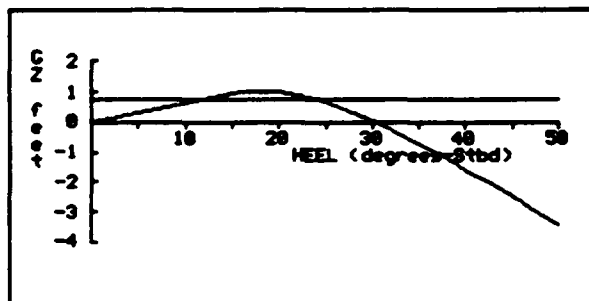

Static Heel = 0.0 deg
 Draft at AP = 9.288 ft
 Draft at FP = 9.612 ft

Gmt (upright damaged) = 3.385 ft
 Angle at Maximum GZ = 19.886 deg
 Maximum GZ = 1.817 ft
 Range of Positive GZ = 38.36 deg

Area to 22.8 degrees = 13.85 ft-deg

DPB1010A:
 175' FERRY

COMPARTMENT FLOODING SUMMARY

At 0.0o Heel	PERM.	FLOODED WTR LTons	% FULL (Damaged)	% FULL (Intact)	SP.VOL. ft3/LT	OUTFLOW LTons
ENGINE ROOM	0.85	145.7	FREE	0.0	----	----
Totals		145.7				

INTACT DATA

Draft at AP = 8.527 ft Kmt = 22.732 ft LCG = 92.114A ft-FP
 Draft at FP = 8.749 ft VCG = 18.880 ft LCB = 92.097A ft-FP
 Displacement = 726.5 LTons GMT = 3.852 ft TCG = 0.000 ft-CL

DRAFT/GZ DATA

HEEL degrees	RIGHTING ARM ft	DRAFT AFT ft	DRAFT FWD ft	FLOODED WATER LTons
0.00	0.000	10.271	8.767	145.7
5.00S	0.260	10.248	8.720	145.6
7.00S	0.373	10.214	8.691	145.5
10.00S	0.557	10.147	8.616	145.2
15.00S	0.856	9.900	8.521	143.4
20.00S	0.826	9.731	8.409	139.9
30.00S	-0.156	9.689	8.270	134.8
40.00S	-1.781	9.809	8.109	132.0
50.00S	-3.600	10.039	7.927	130.2

Note: Drafts are measured at A.P. and F.P along ship's centerline

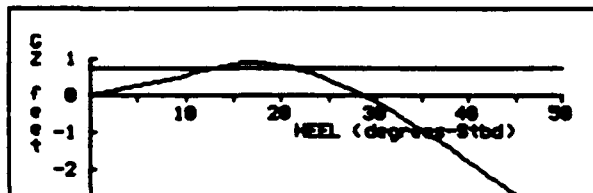

Static Heel = 0.0 deg
 Draft at AP = 10.271 ft
 Draft at FP = 8.767 ft

Gmt (upright damaged) = 3.909 ft
 Angle at Maximum GZ = 10.000 deg
 Maximum GZ = 0.891 ft

DPB1011A:
 175' FERRY

COMPARTMENT FLOODING SUMMARY

At 0.0o Heel	PERM.	FLOODED WTR LTons	% FULL (Damaged)	% FULL (Intact)	SP.VOL. ft3/LT	OUTFLOW LTons
VOID 3	0.95	58.7	FREE	0.0	----	----
Totals		58.7				

INTACT DATA

Draft at AP = 8.527 ft Kmt = 22.732 ft LCG = 92.114A ft-FP
 Draft at FP = 8.749 ft VCG = 18.880 ft LCB = 92.097A ft-FP
 Displacement = 726.5 LTons Gmt = 3.852 ft TCG = 0.000 ft-CL

DRAFT/GZ DATA

HEEL degrees	RIGHTING ARM ft	DRAFT AFT ft	DRAFT FWD ft	FLOODED WATER LTons
0.00	0.000	9.589	8.287	58.7
5.00S	0.242	9.569	8.242	58.9
7.00S	0.346	9.535	8.216	59.0
10.00S	0.507	9.433	8.184	58.9
15.00S	0.795	9.160	8.095	58.6
20.00S	0.935	8.845	8.004	59.0
30.00S	0.094	8.463	7.810	60.6
40.00S	-1.514	8.150	7.548	61.5
50.00S	-3.361	7.764	7.223	61.3

Note: Drafts are measured at A.P. and F.P along ship's centerline

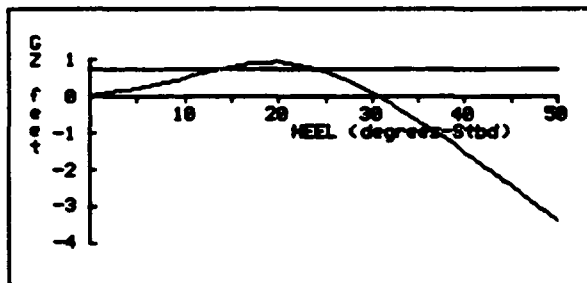

Static Heel = 0.0 deg
 Draft at AP = 9.589 ft
 Draft at FP = 8.287 ft

Gmt (upright damaged) = 2.789 ft
 Angle at Maximum GZ = 21.885 deg
 Maximum GZ = 0.935 ft
 Range of Positive GZ = 38.67 deg

Area to 22.8 degrees = 12.88 ft-deg

DPB1012A:
 175' FERRY

COMPARTMENT FLOODING SUMMARY

At 0.80P Heel	PERM.	FLOODED WTR LTons	% FULL (Damaged)	% FULL (Intact)	SP.VOL. ft ³ /LT	OUTFLOW LTons
VOID 3	0.95	57.7	FREE	0.0	----	----
FO TANK STBD	0.95	8.6	FREE	100.0	40.6000	14.6
Totals		66.3				14.6

INTACT DATA

Draft at AP = 8.527 ft KMT = 22.732 ft LCG = 92.114A ft-FP
 Draft at FP = 8.749 ft VCG = 18.880 ft LCB = 92.097A ft-FP
 Displacement = 726.5 LTons GMT = 3.852 ft TCG = 0.000 ft-CL

DRAFT/GZ DATA

HEEL degrees	RIGHTING ARM ft	DRAFT AFT ft	DRAFT FWD ft	FLOODED WATER LTons
0.00	-0.037	9.469	8.336	66.4
5.00P	0.201	9.435	8.296	65.8
7.00P	0.301	9.391	8.275	65.4
10.00P	0.455	9.273	8.252	64.7
15.00P	0.726	8.964	8.179	63.1
20.00P	0.870	8.585	8.113	62.3
30.00P	0.013	7.992	7.996	61.6
40.00P	-1.628	7.402	7.829	60.8
50.00P	-3.503	6.658	7.624	59.6

Note: Drafts are measured at A.P. and F.P along ship's centerline

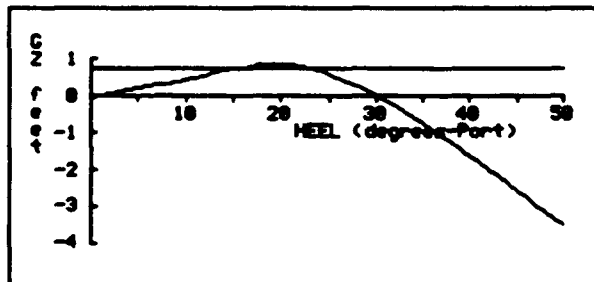

Static Heel = 0.8P deg
 Draft at AP = 9.465 ft
 Draft at FP = 8.331 ft

Angle at Maximum GZ = 21.00P deg
 Maximum GZ = 0.870 ft
 Range of Positive GZ = 29.29 deg

Area to 22.0 degrees = 10.01 ft-deg

DPB1013A:
 175' FERRY

COMPARTMENT FLOODING SUMMARY

At 0.0o Heel	PERM.	FLOODED WTR LTons	% FULL (Damaged)	% FULL (Intact)	SP.VOL. ft3/LT	OUTFLOW LTons
VOID 4	0.95	52.8	FREE	0.0	----	----
Totals		52.8				

INTACT DATA

Draft at AP = 8.527 ft KMT = 22.732 ft LCG = 92.114A ft-FP
 Draft at FP = 8.749 ft VCG = 18.880 ft LCB = 92.097A ft-FP
 Displacement = 726.5 LTons GMT = 3.852 ft TCG = 0.000 ft-CL

DRAFT/GZ DATA

HEEL degrees	RIGHTING ARM ft	DRAFT AFT ft	DRAFT FWD ft	FLOODED WATER LTons
0.00	0.000	9.716	8.020	52.8
5.00S	0.248	9.698	7.973	53.0
7.00S	0.354	9.663	7.947	53.0
10.00S	0.521	9.558	7.918	52.7
15.00S	0.841	9.310	7.815	53.2
20.00S	0.999	9.062	7.675	55.1
30.00S	0.134	8.864	7.328	58.8
40.00S	-1.506	8.803	6.867	61.3
50.00S	-3.384	8.820	6.256	63.1

Note: Drafts are measured at A.P. and F.P along ship's centerline

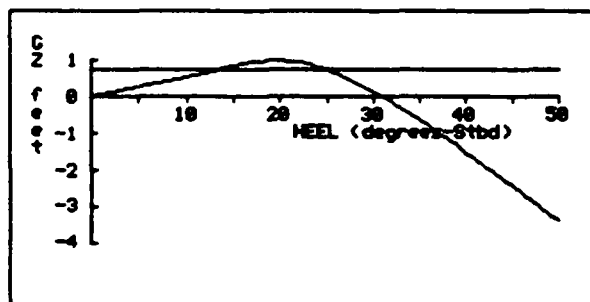

Static Heel = 0.0 deg
 Draft at AP = 9.716 ft
 Draft at FP = 8.020 ft

GM (upright damaged) = 2.771 ft
 Angle at Maximum GZ = 21.00S deg
 Maximum GZ = 0.999 ft
 Range of Positive GZ = 38.94 deg

Area to 22.0 degrees = 12.62 ft-deg

DPB1014A:
 175' FERRY

COMPARTMENT FLOODING SUMMARY

At 0.0o Heel	PERM.	FLOODED WTR LTons	% FULL (Damaged)	% FULL (Intact)	SP.VOL. ft3/LT	OUTFLOW LTons
LAZARETTE	0.95	15.8	FREE	0.0	----	----
Totals		15.8				

INTACT DATA

Draft at AP = 8.527 ft Kmt = 22.732 ft LCG = 92.114A ft-FP
 Draft at FP = 8.749 ft VCG = 18.880 ft LCB = 92.097A ft-FP
 Displacement = 726.5 LTons Gmt = 3.852 ft TCG = 0.000 ft-CL

DRAFT/GZ DATA

HEEL degrees	RIGHTING ARM ft	DRAFT AFT ft	DRAFT FWD ft	FLOODED WATER LTons
0.00	0.000	8.952	8.443	15.8
5.00S	0.269	8.932	8.399	16.2
7.00S	0.384	8.903	8.369	16.8
10.00S	0.570	8.841	8.296	18.1
15.00S	0.902	8.579	8.206	20.1
20.00S	1.114	8.241	8.085	22.9
30.00S	0.280	7.754	7.808	28.3
40.00S	-1.372	7.329	7.447	31.8
50.00S	-3.272	6.853	6.975	34.2

Note: Drafts are measured at A.P. and F.P along ship's centerline

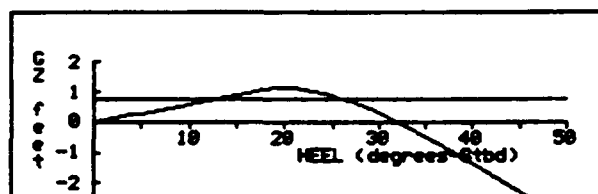

Static Heel = 0.0 deg
 Draft at AP = 8.952 ft
 Draft at FP = 8.443 ft

Gmt (upright damaged) = 3.852 ft
 Angle at Maximum GZ = 21.00S deg
 Maximum GZ = 1.114 ft

RTB1001A:
 175' FERRY

COMPARTMENT FLOODING SUMMARY

At 0.0o Heel	PERM.	FLOODED WTR LTons	% FULL (Damaged)	% FULL (Intact)	SP.VOL. ft3/LT	OUTFLOW LTons
FOREPEAK	0.95	9.1	FREE	0.0	---	---
Totals		9.1				

INTACT DATA

Draft at AP = 8.182 ft KMT = 23.013 ft LCG = 91.393A ft-FP
 Draft at FP = 8.550 ft VCG = 19.280 ft LCB = 91.364A ft-FP
 Displacement = 686.5 LTons GMT = 3.733 ft TCG = 0.000 ft-CL

DRAFT/GZ DATA

HEEL degrees	RIGHTING ARM ft	DRAFT AFT ft	DRAFT FWD ft	FLOODED WATER LTons
0.00	0.000	8.006	8.929	9.1
5.00S	0.320	7.940	8.919	9.1
7.00S	0.446	7.873	8.915	9.1
10.00S	0.636	7.735	8.896	9.1
15.00S	0.958	7.345	8.884	9.1
20.00S	1.204	6.781	8.871	9.2
30.00S	0.481	5.330	9.078	10.3
40.00S	-1.184	3.610	9.439	13.0
50.00S	-3.145	1.434	10.003	16.4

Note: Drafts are measured at A.P. and F.P along ship's centerline

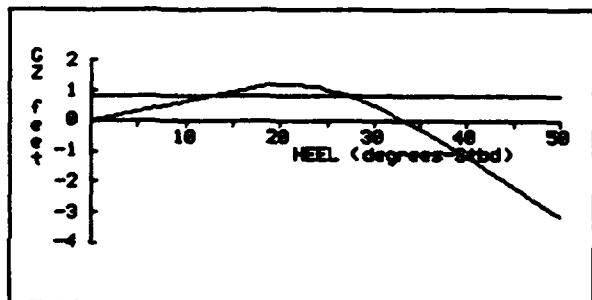

Static Heel = 8.8 deg
 Draft at AP = 8.006 ft
 Draft at FP = 8.929 ft

Gmt (upright damaged) = 3.733 ft
 Angle at Maximum GZ = 22.00S deg
 Maximum GZ = 1.207 ft
 Range of Positive GZ = 33.26 deg

Area to 22.0 degrees = 15.09 ft-deg

RTB1002A:
 175' FERRY

COMPARTMENT FLOODING SUMMARY

At 0.0o Heel	PERM.	FLOODED WTR LTons	% FULL (Damaged)	% FULL (Intact)	SP.VOL. ft3/LT	OUTFLOW LTons
FOREPEAK	0.95	15.6	FREE	0.0	----	----
BOW THRUSTER	0.95	58.9	FREE	0.0	----	----
Totals		74.4				

INTACT DATA

Draft at AP = 8.182 ft Kmt = 23.013 ft LCG = 91.393A ft-FP
 Draft at FP = 8.550 ft VCG = 19.280 ft LCB = 91.364A ft-FP
 Displacement = 686.5 LTons GMT = 3.733 ft TCG = 0.000 ft-CL

DRAFT/GZ DATA

HEEL degrees	RIGHTING ARM ft	DRAFT AFT ft	DRAFT FWD ft	FLOODED WATER LTons
0.00	0.000	7.030	11.146	74.4
5.00S	0.309	6.933	11.170	75.0
7.00S	0.434	6.849	11.182	75.4
10.00S	0.622	6.666	11.208	76.2
15.00S	0.928	6.216	11.276	78.6
20.00S	0.976	5.513	11.612	84.6
30.00S	-0.026	3.368	13.465	104.5
40.00S	-1.768	0.575	16.201	119.8
50.00S	-3.721	-3.056	19.959	129.2

Note: Drafts are measured at A.P. and F.P along ship's centerline

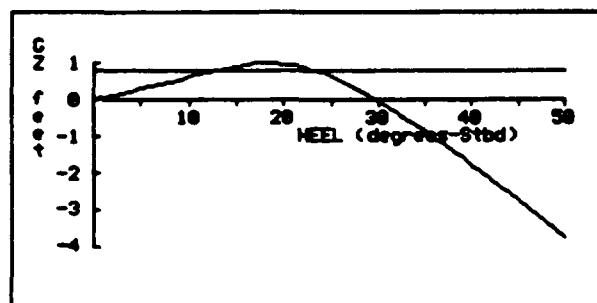

Static Heel = 0.0 deg
 Draft at AP = 7.030 ft
 Draft at FP = 11.146 ft

Gmt (upright damaged) = 3.501 ft
 Angle at Maximum GZ = 19.006 deg
 Maximum GZ = 1.082 ft
 Range of Positive GZ = 29.82 deg

Area to 22.0 degrees = 13.79 ft-deg

RTB1003A:
 175' FERRY

COMPARTMENT FLOODING SUMMARY

At 0.0o Heel	PERM.	FLOODED WTR LTons	% FULL (Damaged)	% FULL (Intact)	SP.VOL. ft3/LT	OUTFLOW LTons
BOW THRUSTER	0.95	52.1	FREE	0.0	----	----
Totals		52.1				

INTACT DATA

Draft at AP = 8.182 ft KMT = 23.013 ft LCG = 91.393A ft-FP
 Draft at FP = 8.550 ft VCG = 19.280 ft LCB = 91.364A ft-FP
 Displacement = 686.5 LTons GMT = 3.733 ft TCG = 0.000 ft-CL

DRAFT/GZ DATA

HEEL degrees	RIGHTING ARM ft	DRAFT AFT ft	DRAFT FWD ft	FLOODED WATER LTons
0.00	0.000	7.444	10.313	52.1
5.00S	0.309	7.358	10.325	52.4
7.00S	0.434	7.280	10.332	52.6
10.00S	0.620	7.113	10.343	53.2
15.00S	0.932	6.704	10.356	54.5
20.00S	1.063	6.081	10.514	57.7
30.00S	0.198	4.354	11.462	66.5
40.00S	-1.473	2.310	12.656	71.2
50.00S	-3.396	-0.201	14.162	73.8

Note: Drafts are measured at A.P. and F.P along ship's centerline

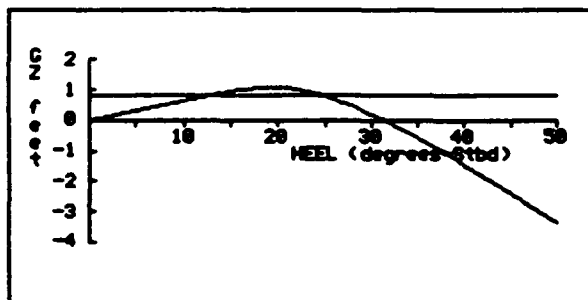

Static Heel = 0.0 deg
 Draft at AP = 7.444 ft
 Draft at FP = 10.313 ft

Gmt (upright damaged) = 3.516 ft
 Angle at Maximum GZ = 20.00S deg
 Maximum GZ = 1.066 ft
 Range of Positive GZ = 31.36 deg

Area to 22.0 degrees = 14.19 ft-deg

RTB1004A:
 175' FERRY

COMPARTMENT FLOODING SUMMARY

At 0.0o Heel	PERM.	FLOODED WTR LTons	% FULL (Damaged)	% FULL (Intact)	SP.VOL. ft3/LT	OUTFLOW LTons
VOID 1	0.95	75.6	FREE	0.0	----	----
Totals		75.6				

INTACT DATA

Draft at AP = 8.182 ft Kmt = 23.013 ft LCG = 91.393A ft-FP
 Draft at FP = 8.550 ft VCG = 19.280 ft LCB = 91.364A ft-FP
 Displacement = 686.5 LTons Gmt = 3.733 ft TCG = 0.000 ft-CL

DRAFT/GZ DATA

HEEL degrees	RIGHTING ARM ft	DRAFT AFT ft	DRAFT FWD ft	FLOODED WATER LTons
0.00	0.000	7.523	10.584	75.6
5.00S	0.280	7.443	10.590	76.0
7.00S	0.394	7.367	10.595	76.3
10.00S	0.562	7.209	10.600	76.9
15.00S	0.839	6.814	10.605	78.4
20.00S	0.931	6.241	10.723	80.1
30.00S	0.097	4.762	11.367	81.2
40.00S	-1.554	3.001	12.239	81.1
50.00S	-3.456	0.853	13.333	80.4

Note: Drafts are measured at A.P. and F.P along ship's centerline

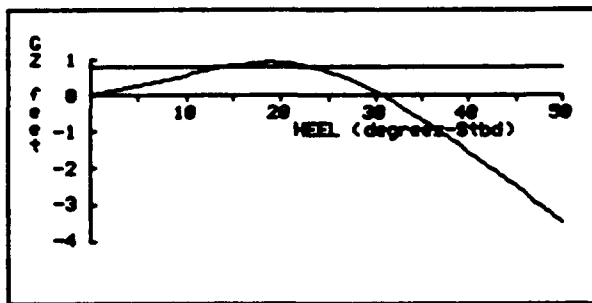

Static Heel = 0.0 deg
 Draft at AP = 7.523 ft
 Draft at FP = 10.584 ft

Gut (upright damaged) = 3.226 ft
 Angle at Maximum GZ = 20.00S deg
 Maximum GZ = 0.939 ft
 Range of Positive GZ = 30.69 deg

Area to 22.8 degrees = 12.69 ft-deg

RTB1005A:
 175' FERRY

COMPARTMENT FLOODING SUMMARY

At 0.0o Heel	PERM.	FLOODED WTR LTons	% FULL (Damaged)	% FULL (Intact)	SP.VOL. ft ³ /LT	OUTFLOW LTons
VOID 2	0.95	124.9	FREE	0.0	----	----
Totals		124.9				

INTACT DATA

Draft at AP = 8.182 ft Kmt = 23.013 ft LCG = 91.393A ft-FP
 Draft at FP = 8.550 ft VCG = 19.280 ft LCB = 91.364A ft-FP
 Displacement = 686.5 LTons GMT = 3.733 ft TCG = 0.000 ft-CL

DRAFT/GZ DATA

HEEL degrees	RIGHTING ARM ft	DRAFT AFT ft	DRAFT FWD ft	FLOODED WATER LTons
0.00	0.000	7.786	11.018	124.9
5.00S	0.255	7.719	11.010	125.1
7.00S	0.357	7.652	11.006	125.3
10.00S	0.511	7.512	10.993	125.8
15.00S	0.757	7.154	10.964	126.5
20.00S	0.795	6.647	11.057	125.4
30.00S	-0.103	5.370	11.660	120.9
40.00S	-1.747	3.902	12.439	116.6
50.00S	-3.619	2.065	13.485	113.0

Note: Drafts are measured at A.P. and F.P along ship's centerline

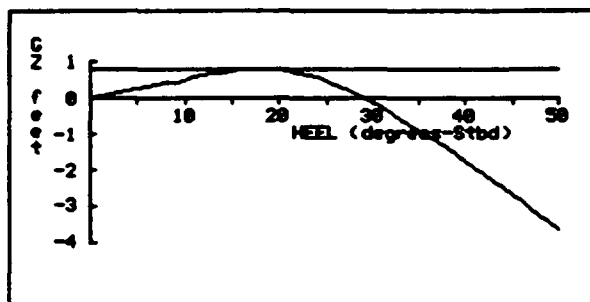

Static Heel = 0.0 deg
 Draft at AP = 7.786 ft
 Draft at FP = 11.018 ft

Gmt (upright damaged) = 3.888 ft
 Angle at Maximum GZ = 19.888 deg
 Maximum GZ = 0.818 ft
 Range of Positive GZ = 29.24 deg

Area to 22.8 degrees = 11.28 ft-deg

RTB1006A:
 175' FERRY

COMPARTMENT FLOODING SUMMARY

At 0.2oS Heel	PERM.	FLOODED WTR LTons	% FULL (Damaged)	% FULL (Intact)	SP.VOL. ft ³ /LT	OUTFLOW LTons
VOID 2	0.95	125.4	FREE	0.0	----	----
FRESH H2O ST	0.95	3.9	FREE	10.0	35.8800	0.9
Totals		129.4				0.9

INTACT DATA

Draft at AP = 8.182 ft KMT = 23.013 ft LCG = 91.393A ft-FP
 Draft at FP = 8.550 ft VCG = 19.280 ft LCB = 91.364A ft-FP
 Displacement = 686.5 LTons GMT = 3.733 ft TCG = 0.000 ft-CL

DRAFT/GZ DATA

HEEL degrees	RIGHTING ARM ft	DRAFT AFT ft	DRAFT FWD ft	FLOODED WATER LTons
0.00	-0.013	7.781	11.078	129.4
5.00S	0.244	7.714	11.075	129.9
7.00S	0.347	7.647	11.074	130.3
10.00S	0.504	7.507	11.062	130.9
15.00S	0.752	7.148	11.038	131.8
20.00S	0.786	6.643	11.141	130.8
30.00S	-0.120	5.373	11.783	127.1
40.00S	-1.772	3.912	12.630	123.8
50.00S	-3.653	2.082	13.791	121.3

Note: Drafts are measured at A.P. and F.P along ship's centerline

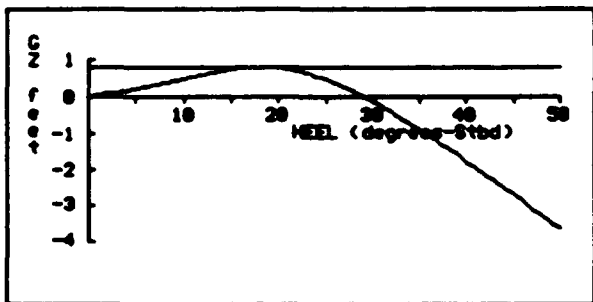

Static Heel = 0.25 deg
 Draft at AP = 7.779 ft
 Draft at FP = 11.078 ft

Angle at Maximum GZ = 19.000 deg
 Maximum GZ = 0.811 ft
 Range of Positive GZ = 28.87 deg

Area to 22.0 degrees = 11.09 ft-deg

RTB1007A:
 175' FERRY

COMPARTMENT FLOODING SUMMARY

At 0.0o Heel	PERM.	FLOODED WTR LTons	% FULL (Damaged)	% FULL (Intact)	SP.VOL. ft3/LT	OUTFLOW LTons
CREW QUARTER	0.95	113.5	FREE	0.0	----	----
Totals		113.5				

INTACT DATA

Draft at AP = 8.182 ft KMT = 23.013 ft LCG = 91.393A ft-FP
 Draft at FP = 8.550 ft VCG = 19.280 ft LCB = 91.364A ft-FP
 Displacement = 686.5 LTons GMT = 3.733 ft TCG = 0.000 ft-CL

DRAFT/GZ DATA

HEEL degrees	RIGHTING ARM ft	DRAFT AFT ft	DRAFT FWD ft	FLOODED WATER LTons
0.00	0.000	8.417	10.058	113.5
5.00S	0.283	8.368	10.033	113.4
7.00S	0.395	8.314	10.018	113.3
10.00S	0.568	8.197	9.978	113.1
15.00S	0.852	7.857	9.920	112.4
20.00S	0.940	7.388	9.933	110.3
30.00S	0.037	6.331	10.228	104.7
40.00S	-1.632	5.162	10.614	100.9
50.00S	-3.531	3.707	11.137	98.2

Note: Drafts are measured at A.P. and F.P along ship's centerline

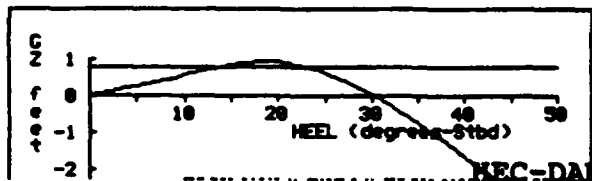

Static Heel = 0.0 deg
 Draft at AP = 8.417 ft
 Draft at FP = 10.058 ft

Gmt (upright damaged) = 3.240 ft
 Angle at Maximum GZ = 20.000 deg

RTB1008A:
 175' FERRY

COMPARTMENT FLOODING SUMMARY

At 0.0o Heel	PERM.	FLOODED WTR LTons	% FULL (Damaged)	% FULL (Intact)	SP.VOL. ft3/LT	OUTFLOW LTons
STORE ROOM	0.95	102.4	FREE	0.0	----	----
Totals		102.4				

INTACT DATA

Draft at AP = 8.182 ft KMT = 23.013 ft LCG = 91.393A ft-FP
 Draft at FP = 8.550 ft VCG = 19.280 ft LCB = 91.364A ft-FP
 Displacement = 686.5 LTons GMT = 3.733 ft TCG = 0.000 ft-CL

DRAFT/GZ DATA

HEEL degrees	RIGHTING ARM ft	DRAFT AFT ft	DRAFT FWD ft	FLOODED WATER LTons
0.00	0.000	8.848	9.328	102.4
5.00S	0.269	8.812	9.293	102.2
7.00S	0.377	8.765	9.273	102.1
10.00S	0.544	8.661	9.224	101.7
15.00S	0.824	8.329	9.163	100.4
20.00S	0.926	7.879	9.135	97.8
30.00S	0.018	6.963	9.257	92.8
40.00S	-1.648	6.009	9.410	90.6
50.00S	-3.548	4.826	9.634	89.4

Note: Drafts are measured at A.P. and F.P along ship's centerline

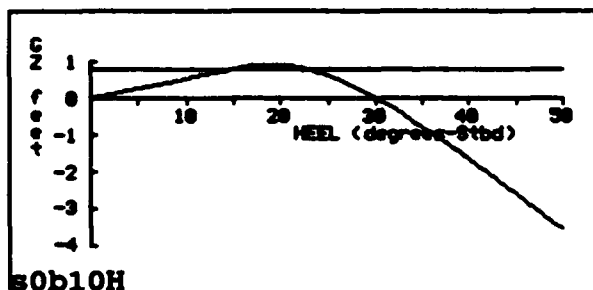

Static Heel = 0.0 deg
 Draft at AP = 8.848 ft
 Draft at FP = 9.328 ft

Gut (upright damaged) = 3.878 ft
 Angle at Maximum GZ = 20.00S deg
 Maximum GZ = 0.934 ft
 Range of Positive GZ = 30.12 deg

Area to 22.0 degrees = 12.43 ft-deg

RTB1009A:
 175' FERRY

COMPARTMENT FLOODING SUMMARY

At 0.0o Heel	PERM.	FLOODED WTR LTons	% FULL (Damaged)	% FULL (Intact)	SP.VOL. ft3/LT	OUTFLOW LTons
SEWAGE TANK	0.95	9.8	FREE	100.0	35.0063	9.8
STORE ROOM	0.95	102.4	FREE	0.0	----	----
Totals		112.1				9.8

INTACT DATA

Draft at AP = 8.182 ft Kmt = 23.013 ft LCG = 91.393A ft-FP
 Draft at FP = 8.550 ft VCG = 19.280 ft LCB = 91.364A ft-FP
 Displacement = 686.5 LTons Gmt = 3.733 ft TCG = 0.000 ft-CL

DRAFT/GZ DATA

HEEL degrees	RIGHTING ARM ft	DRAFT AFT ft	DRAFT FWD ft	FLOODED WATER LTons
0.00	0.000	8.848	9.328	112.1
5.00S	0.273	8.812	9.293	112.0
7.00S	0.383	8.765	9.273	111.8
10.00S	0.552	8.661	9.224	111.4
15.00S	0.836	8.329	9.163	110.2
20.00S	0.939	7.879	9.135	107.6
30.00S	0.009	6.948	9.252	101.7
40.00S	-1.695	5.949	9.393	98.0
50.00S	-3.632	4.697	9.602	95.4

Note: Drafts are measured at A.P. and F.P along ship's centerline

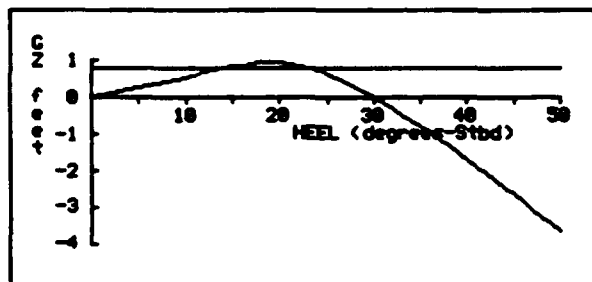

Static Heel = 0.0 deg
 Draft at AP = 8.848 ft
 Draft at FP = 9.328 ft

Gmt (upright damaged) = 3.122 ft
 Angle at Maximum GZ = 22.885 deg
 Maximum GZ = 0.947 ft
 Range of Positive GZ = 30.86 deg

Area to 22.8 degrees = 12.61 ft-deg

RTB1010A:
 175' FERRY

COMPARTMENT FLOODING SUMMARY

At 0.0o Heel	PERM.	FLOODED WTR LTons	% FULL (Damaged)	% FULL (Intact)	SP.VOL. ft ³ /LT	OUTFLOW LTons
ENGINE ROOM	0.85	138.4	FREE	0.0	----	----
Totals		138.4				

INTACT DATA

Draft at AP = 8.182 ft KMt = 23.013 ft LCG = 91.393A ft-FP
 Draft at FP = 8.550 ft VCG = 19.280 ft LCB = 91.364A ft-FP
 Displacement = 686.5 LTons GMT = 3.733 ft TCG = 0.000 ft-CL

DRAFT/GZ DATA

HEEL degrees	RIGHTING ARM ft	DRAFT AFT ft	DRAFT FWD ft	FLOODED WATER LTons
0.00	0.000	9.865	8.559	138.4
5.00S	0.245	9.839	8.516	138.3
7.00S	0.350	9.804	8.489	138.2
10.00S	0.519	9.728	8.420	137.9
15.00S	0.807	9.440	8.343	136.1
20.00S	0.849	9.135	8.255	132.2
30.00S	-0.112	8.754	8.131	127.1
40.00S	-1.788	8.452	7.968	124.3
50.00S	-3.679	8.136	7.760	122.4

Note: Drafts are measured at A.P. and F.P. along ship's centerline

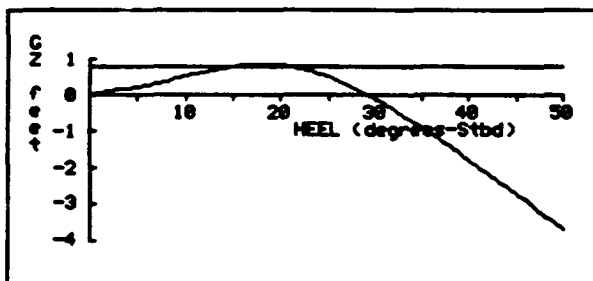

Static Heel = 0.0 deg
 Draft at AP = 9.865 ft
 Draft at FP = 8.559 ft

Gct (upright damaged) = 2.729 ft
 Angle at Maximum GZ = 19.885 deg
 Maximum GZ = 0.876 ft
 Range of Positive GZ = 29.21 deg

Area to 22.0 degrees = 11.75 ft-deg

RTB1011A:
 175' FERRY

COMPARTMENT FLOODING SUMMARY

At 0.0o Heel	PERM.	FLOODED WTR LTons	% FULL (Damaged)	% FULL (Intact)	SP.VOL. ft ³ /LT	OUTFLOW LTons
VOID 3	0.95	54.5	FREE	0.0	----	----
Totals		54.5				

INTACT DATA

Draft at AP = 8.182 ft Kmt = 23.013 ft LCG = 91.393A ft-FP
 Draft at FP = 8.550 ft VCG = 19.280 ft LCB = 91.364A ft-FP
 Displacement = 686.5 LTons GMT = 3.733 ft TCG = 0.000 ft-CL

DRAFT/GZ DATA

HEEL degrees	RIGHTING ARM ft	DRAFT AFT ft	DRAFT FWD ft	FLOODED WATER LTons
0.00	0.000	9.186	8.108	54.5
5.00S	0.230	9.161	8.068	54.6
7.00S	0.324	9.120	8.047	54.6
10.00S	0.470	9.003	8.025	54.4
15.00S	0.731	8.698	7.957	54.1
20.00S	0.925	8.298	7.880	55.1
30.00S	0.108	7.622	7.692	57.4
40.00S	-1.548	6.940	7.427	58.5
50.00S	-3.464	6.035	7.103	58.1

Note: Drafts are measured at A.P. and F.P along ship's centerline

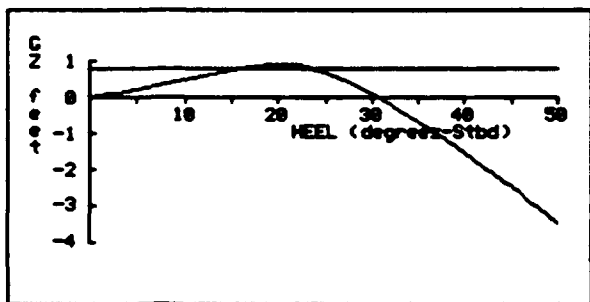

Static Heel = 0.0 deg
 Draft at AP = 9.186 ft
 Draft at FP = 8.108 ft

Gzt (upright damaged) = 2.585 ft
 Angle at Maximum GZ = 21.00S deg
 Maximum GZ = 0.925 ft
 Range of Positive GZ = 30.76 deg

Area to 22.0 degrees = 11.37 ft-deg

RTB1012A:
 175' FERRY

COMPARTMENT FLOODING SUMMARY

At 1.0oS Heel	PERM.	FLOODED WTR LTons	% FULL (Damaged)	% FULL (Intact)	SP.VOL. ft ³ /LT	OUTFLOW LTons
VOID 3	0.95	55.7	FREE	0.0	----	----
FO TANK STBD	0.95	8.6	FREE	10.0	40.6000	1.5
Totals		64.2				1.5

INTACT DATA

Draft at AP = 8.182 ft KMt = 23.013 ft LCG = 91.393A ft-FP
 Draft at FP = 8.550 ft VCG = 19.280 ft LCB = 91.364A ft-FP
 Displacement = 686.5 LTons GMT = 3.733 ft TCG = 0.000 ft-CL

DRAFT/GZ DATA

HEEL degrees	RIGHTING ARM ft	DRAFT AFT ft	DRAFT FWD ft	FLOODED WATER LTons
0.00	-0.046	9.330	8.048	64.1
5.00S	0.191	9.318	8.004	64.9
7.00S	0.290	9.285	7.978	65.2
10.00S	0.445	9.180	7.950	65.4
15.00S	0.724	8.893	7.872	65.4
20.00S	0.916	8.524	7.783	66.4
30.00S	0.087	7.984	7.548	69.4
40.00S	-1.576	7.514	7.211	71.8
50.00S	-3.500	6.955	6.768	73.2

Note: Drafts are measured at A.P. and F.P along ship's centerline

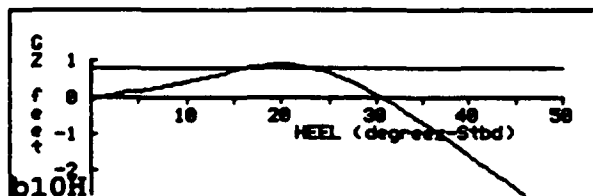

Static Heel = 1.0S deg
 Draft at AP = 9.329 ft
 Draft at FP = 8.048 ft

Angle at Maximum GZ = 21.00S deg
 Maximum GZ = 0.916 ft
 Range of Positive GZ = 29.61 deg

RTB1013A:
 175' FERRY

COMPARTMENT FLOODING SUMMARY

At 0.0o Heel	PERM.	FLOODED WTR LTons	% FULL (Damaged)	% FULL (Intact)	SP.VOL. ft3/LT	OUTFLOW LTons
VOID 4	0.95	46.8	FREE	0.0	----	----
Totals		46.8				

INTACT DATA

Draft at AP = 8.182 ft Kmt = 23.013 ft LCG = 91.393A ft-FP
 Draft at FP = 8.550 ft VCG = 19.280 ft LCB = 91.364A ft-FP
 Displacement = 686.5 LTons Gmt = 3.733 ft TCG = 0.000 ft-CL

DRAFT/GZ DATA

HEEL degrees	RIGHTING ARM ft	DRAFT AFT ft	DRAFT FWD ft	FLOODED WATER LTons
0.00	0.000	9.256	7.887	46.8
5.00S	0.236	9.232	7.847	46.9
7.00S	0.333	9.189	7.827	46.8
10.00S	0.487	9.071	7.808	46.5
15.00S	0.789	8.797	7.722	47.4
20.00S	1.003	8.438	7.610	49.3
30.00S	0.162	7.881	7.301	52.9
40.00S	-1.521	7.382	6.871	55.4
50.00S	-3.465	6.810	6.299	57.2

Note: Drafts are measured at A.P. and F.P along ship's centerline

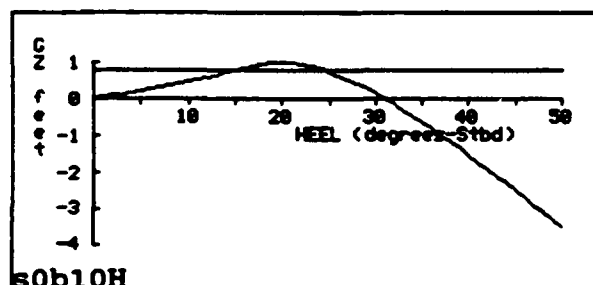

Static Heel = 0.0 deg
 Draft at AP = 9.256 ft
 Draft at FP = 7.887 ft

Gmt (upright damaged) = 2.647 ft
 Angle at Maximum GZ = 21.885 deg
 Maximum GZ = 1.883 ft
 Range of Positive GZ = 31.10 deg

Area to 22.0 degrees = 12.13 ft-deg

RTB1014A:
 175' FERRY

COMPARTMENT FLOODING SUMMARY

At 0.0o Heel	PERM.	FLOODED WTR LTons	% FULL (Damaged)	% FULL (Intact)	SP.VOL. ft3/LT	OUTFLOW LTons
LAZARETTE	0.95	11.1	FREE	0.0	----	----
Totals		11.1				

INTACT DATA

Draft at AP = 8.182 ft Kmt = 23.013 ft LCG = 91.393A ft-FP
 Draft at FP = 8.550 ft VCG = 19.280 ft LCB = 91.364A ft-FP
 Displacement = 686.5 LTons Gmt = 3.733 ft TCG = 0.000 ft-CL

DRAFT/GZ DATA

HEEL degrees	RIGHTING ARM ft	DRAFT AFT ft	DRAFT FWD ft	FLOODED WATER LTons
0.00	0.000	8.490	8.328	11.1
5.00S	0.261	8.469	8.286	12.1
7.00S	0.372	8.436	8.259	12.8
10.00S	0.545	8.361	8.196	14.2
15.00S	0.852	8.068	8.125	16.3
20.00S	1.093	7.638	8.026	18.5
30.00S	0.285	6.803	7.786	23.7
40.00S	-1.406	5.954	7.455	27.2
50.00S	-3.366	4.934	7.008	29.7

Note: Drafts are measured at A.P. and F.P along ship's centerline

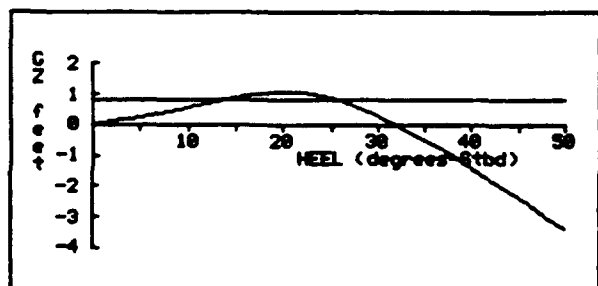

Static Heel = 0.0 deg
 Draft at AP = 8.490 ft
 Draft at FP = 8.328 ft

Gmt (upright damaged) = 2.887 ft
 Angle at Maximum GZ = 21.886 deg
 Maximum GZ = 1.093 ft
 Range of Positive GZ = 31.91 deg

Area to 22.0 degrees = 13.28 ft-deg

**APPENDIX B
HYDROSTATICS AND
DAMAGE STABILITY
OUTPUT**

192' FERRY

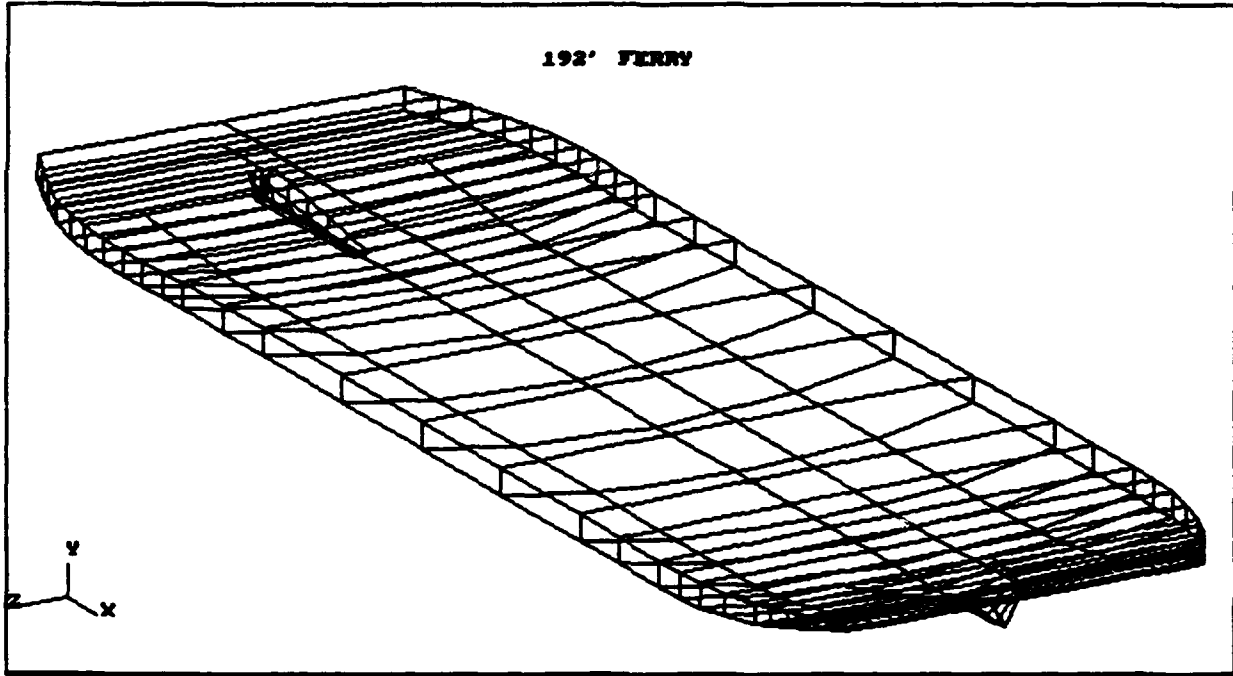

**DAMAGE STABILITY SUMMARY
 192' FERRY**

CAL. No.	FILE NAME	DAMAGED COMP. LISTING	---Intact Condition---			-----Equilibrium Condition After Damage-----					
			MN.DRAFT (ft)	VCG (ft)	GMT (ft)	HEEL (deg)	MAX.GZ (ft)	RANGE (deg)	AREA (ft-deg)	DAM.GMT (ft)	SURVIVAL
1	DPTA001A	1,2	6.380	17.340	74.445	0.5S	7.941	47.64	133.36	----	Yes
2	DPTA002A	1,2,3	6.380	17.340	74.445	0.7S	7.219	44.85	121.69	----	Yes
3	DPTA003A	2	6.380	17.340	74.445	0.4S	8.783	50.28	147.07	----	Yes
4	DPTA004A	6,2	6.380	17.340	74.445	1.0S	7.536	46.73	123.98	----	Yes
5	DPTA005A	6	6.380	17.340	74.445	0.4S	8.884	50.57	148.81	----	Yes
6	DPTA006A	6,9	6.380	17.340	74.445	0.9S	7.704	47.25	127.07	----	Yes
7	DPTA007A	9	6.380	17.340	74.445	0.4S	8.887	50.59	148.86	----	Yes
8	DPTA008A	9,11	6.380	17.340	74.445	1.6S	6.458	43.30	104.09	----	Yes
9	DPTA009A	11	6.380	17.340	74.445	1.0S	7.651	47.13	125.97	----	Yes
10	DPTA010A	11,13	6.380	17.340	74.445	1.7S	6.377	42.94	101.95	----	Yes
11	DPTA011A	13	6.380	17.340	74.445	0.5S	8.828	50.51	147.69	----	Yes
12	DPTA012A	13,15	6.380	17.340	74.445	0.7S	7.272	45.84	121.81	----	Yes
13	DPTA013A	15,16	6.380	17.340	74.445	0.0	7.705	46.86	133.06	59.835	Yes
14	DPTA014A	1,2,3,4	6.380	17.340	74.445	0.6S	7.343	44.58	124.38	----	Yes
15	DPTA015A	2,3,4,6,7	6.380	17.340	74.445	0.8S	7.673	44.54	128.17	----	Yes
16	DPTA016A	6,7,9,10	6.380	17.340	74.445	1.2S	7.307	43.97	120.05	----	Yes
17	DPTA017A	9,10,11	6.380	17.340	74.445	2.2S	5.586	39.72	88.46	----	Yes
18	DPTA018A	9,10,11,12	6.380	17.340	74.445	4.0S	1.320	16.96	14.62	----	No *F
19	DPTA019A	11,12,13	6.380	17.340	74.445	3.2S	2.327	23.48	32.52	----	No *F
20	DPTA020A	12,13,15	6.380	17.340	74.445	4.4S	0.137	3.04	0.26	----	No *F *C

*F WARNING: The required GMT for non-survival cases does not meet all survival criteria.

*C WARNING: Damage stability calculations did not converge at all angles.

**DAMAGE STABILITY SUMMARY
 192' FERRY**

C.A. No.	FILE NAME	DAMAGED COMP. LISTING	---Intact Condition---			-----Equilibrium Condition After Damage-----					
			MN.DRAFT (ft)	VCG (ft)	GMT (ft)	HEEL (deg)	MAX.GZ (ft)	RANGE (deg)	AREA (ft-deg)	DAM.GMT (ft)	SURVIVAL
1	DPTB001B	1,2	6.585	16.530	71.292	0.6S	7.566	48.05	127.87	----	Yes
2	DPTB002B	1,2,3	6.585	16.530	71.292	0.7S	6.815	44.94	115.39	----	Yes
3	DPTB003B	2	6.585	16.530	71.292	0.5S	8.423	50.90	142.04	----	Yes
4	DPTB004B	6,2	6.585	16.530	71.292	1.0S	7.203	47.20	119.17	----	Yes
5	DPTB005B	6	6.585	16.530	71.292	0.4S	8.524	51.20	143.76	----	Yes
6	DPTB006B	6,9	6.585	16.530	71.292	1.0S	7.352	47.74	122.05	----	Yes
7	DPTB007B	9	6.585	16.530	71.292	0.4S	8.524	51.20	143.75	----	Yes
8	DPTB008B	9,11	6.585	16.530	71.292	1.7S	6.120	43.54	99.01	----	Yes
9	DPTB009B	11	6.585	16.530	71.292	1.0S	7.296	47.56	120.75	----	Yes
10	DPTB010B	11,13	6.585	16.530	71.292	1.7S	6.044	43.12	96.87	----	Yes
11	DPTB011B	13	6.585	16.530	71.292	0.5S	8.474	51.09	142.57	----	Yes
12	DPTB012B	13,15	6.585	16.530	71.292	0.7S	6.850	45.91	115.31	----	Yes
13	DPTB013B	15,16	6.585	16.530	71.292	0.0	7.228	46.75	125.38	57.521	Yes
14	DPTB014B	1,2,3,4	6.585	16.530	71.292	0.6S	6.890	44.64	117.34	----	Yes
15	DPTB015B	2,3,4,6,7	6.585	16.530	71.292	0.9S	7.187	44.67	120.59	----	Yes
16	DPTB016B	6,7,9,10	6.585	16.530	71.292	1.3S	6.817	44.09	112.69	----	Yes
17	DPTB017B	9,10,11	6.585	16.530	71.292	2.3S	5.195	39.60	82.52	----	Yes
18	DPTB018B	9,10,11,12	6.585	16.530	71.292	5.0S	0.559	11.35	4.21	----	No *F
19	DPTB019B	11,12,13	6.585	16.530	71.292	3.6S	1.570	19.58	19.81	----	Yes
20	DPTB020B	12,13,15	6.585	16.530	71.292	0.0	0.000	0.00	0.00	51.696	Plunges *F *C

*F WARNING: The required GMT for non-survival cases does not meet all survival criteria.

*C WARNING: Damage stability calculations did not converge at all angles.

HYDROSTATIC TABLES
 192' FERRY

MOLDED DRAFT (ft)	4.000	4.500	5.000	5.500	6.000	6.500	7.000	7.500
DISP.MLD. (LTons-SW)	632.6	767.8	914.3	1,069.6	1,231.8	1,403.0	1,576.3	1,750.6
DISP.TOTAL (LTons-SW)	644.0	780.6	928.6	1,085.2	1,248.8	1,421.5	1,595.8	1,771.3
DISP.TOTAL (LTons-FW)	628.3	761.6	906.0	1,058.8	1,218.4	1,386.8	1,556.9	1,728.1
LCB (ft-FP)	90.999A	91.072A	91.248A	91.459A	91.854A	92.574A	93.114A	93.495A
TCB (ft-CL)	0.000	0.000	0.000	0.000	0.000	0.000	0.000	0.000
KB (ft)	2.499	2.806	3.116	3.425	3.729	4.036	4.333	4.622
BMt (ft)	110.122	111.989	115.494	104.158	94.630	86.008	77.224	69.993
KMt (ft)	112.621	114.795	118.610	107.583	98.360	90.044	81.557	74.616
BML (ft)	848.151	779.611	732.780	711.616	700.969	693.167	629.130	585.418
KML (ft)	850.650	782.416	735.896	715.040	704.699	697.203	633.463	590.040
TPI (LTons)	21.67	23.46	25.37	26.52	27.66	28.76	28.95	29.26
MTlin (ft-LTons)	233.1	260.1	291.1	330.7	375.2	422.5	430.9	445.3
MTlin (LTons)	-0.52	-0.50	-0.49	-0.26	-0.08	0.30	0.21	0.06
LL. (ft-FP)	91.330A	91.804A	92.234A	94.043A	95.366A	97.874A	97.272A	96.265A
W.P. AREA (ft2)	9,104.1	9,856.8	10,658.4	11,140.5	11,620.3	12,080.0	12,159.4	12,290.3
WETTED SUR. (ft2)	9,396.3	10,182.5	11,016.1	11,651.5	12,299.1	12,965.4	13,256.3	13,601.2
MAX. BEAM (ft)	58.219	62.030	65.891	65.965	65.965	65.965	65.965	65.965
LENGTH W.L. (ft)	181.258	181.455	181.652	181.850	186.543	191.816	192.059	192.309
Cb	0.4373	0.4718	0.5057	0.5378	0.5677	0.5969	0.6227	0.6455
Cm	0.5754	0.6127	0.6483	0.6801	0.7067	0.7291	0.7484	0.7650
Cp	0.7601	0.7702	0.7801	0.7908	0.8034	0.8187	0.8321	0.8437
Cwp	0.7192	0.7786	0.8420	0.8801	0.9180	0.9543	0.9606	0.9709
Cit	0.5307	0.6551	0.8045	0.8487	0.8880	0.9193	0.9273	0.9334

Assumes: Sea Water at 35.0063 ft3/LT
 Fresh Water at 35.8814 ft3/LT
 Ship floating at even keel (no heel or trim)

DPTA001A: DPTA1
 192' FERRY

Damaged Compartments:
 VOID1 BALLAST1

	DISPLACEMENT LTons	DRAFT AFT ft	DRAFT FWD ft	TRIM ft	HEEL deg.	UPRIGHT GMT ft
INTACT	1,382.9	6.750	6.010	0.740A	0.00	74.445
DAMAGED	1,461.3	6.347	6.866	0.519F	0.52S	65.082

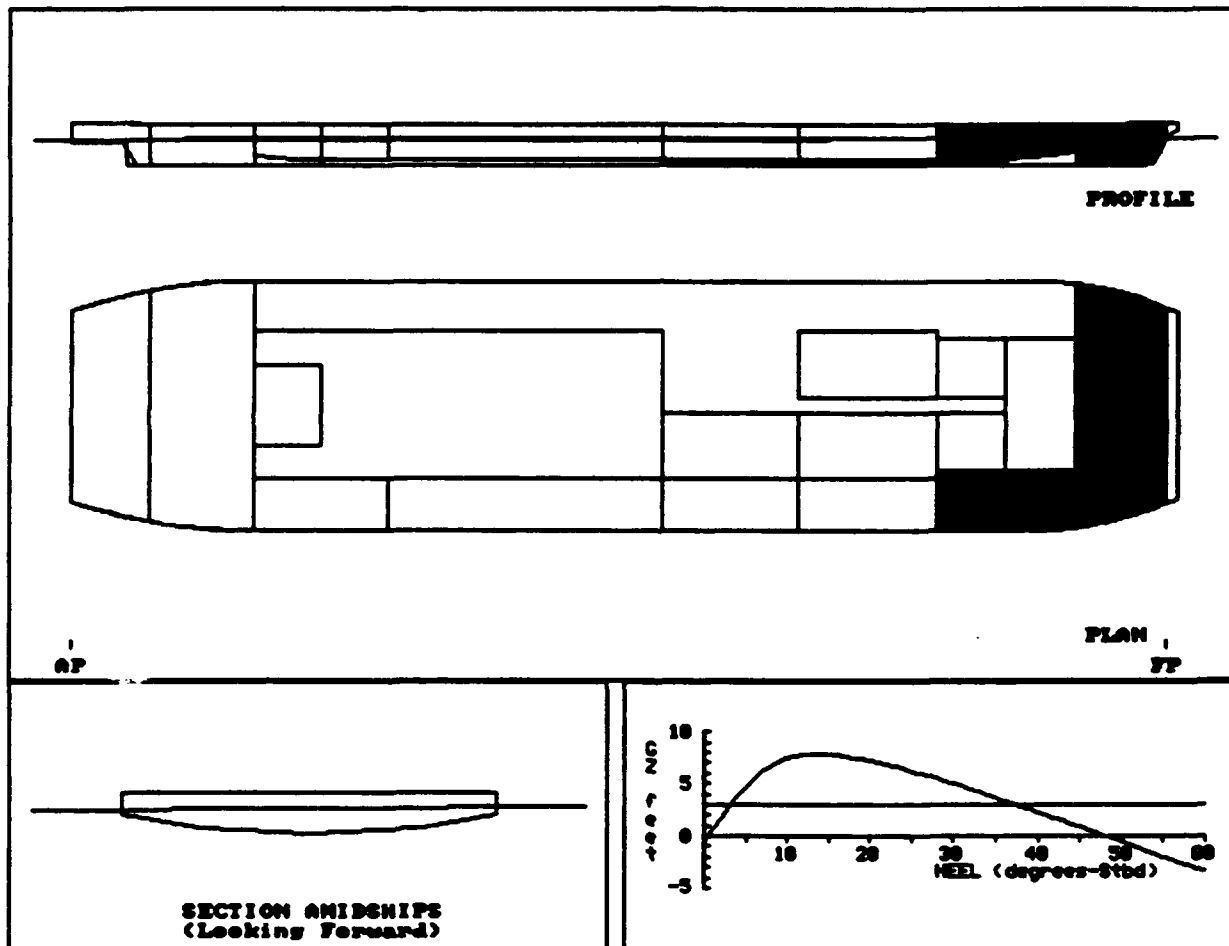

DPTA001A: DPRTA1
 192' FERRY

COMPARTMENT FLOODING SUMMARY

At 0.5oS Heel	PERM.	FLOODED WTR LTons	% FULL (Damaged)	% FULL (Intact)	SP.VOL. ft ³ /LT	OUTFLOW LTons
VOID1	0.95	42.0	FREE	0.0	----	----
BALLAST1	0.95	36.4	FREE	0.0	----	----
Totals		78.4				

INTACT DATA

Draft at AP = 6.750 ft Kmt = 91.785 ft LCG = 95.090A ft-FP
 Draft at FP = 6.010 ft VCG = 17.340 ft LCB = 95.142A ft-FP
 Displacement = 1382.9 LTons GMT = 74.445 ft TCG = 0.000 ft-CL

DRAFT/GZ DATA

HEEL degrees	RIGHTING ARM ft	DRAFT AFT ft	DRAFT FWD ft	FLOODED WATER LTons
0.00	-0.585	6.390	6.829	75.4
7.00S	6.143	5.744	7.348	128.5
10.00S	7.442	5.241	7.644	140.4
15.00S	7.828	4.498	8.368	147.9
20.00S	7.226	3.726	9.344	153.0
30.00S	5.030	2.047	11.662	158.7
40.00S	2.335	-0.061	14.707	162.3
50.00S	-0.530	-2.886	18.876	164.7
60.00S	-3.421	-7.324	25.363	166.6

Note: Drafts are measured at A.P. and F.P along ship's centerline

GZ SUMMARY (Evaluated per IMO (SOLAS'90) Rules for Passenger Ships)
 Available Required

Static Heel Angle	0.52S deg	7.00 deg
Angle at Maximum GZ	15.00S deg	
Maximum GZ	7.866 ft	3.000 ft
Range of Positive GZ	47.65 deg	15.00 deg
Righting Area (0.52-1.00)	133.033 ft-deg	2.820 ft-deg

DPTA002A: DPRTA2
 192' FERRY

Damaged Compartments:

VOID1 BALLAST1 BOWTHRUST

	DISPLACEMENT LTons	DRAFT AFT ft	DRAFT FWD ft	TRIM ft	HEEL deg.	UPRIGHT GMt ft
INTACT	1,382.9	6.750	6.010	0.740A	0.00	74.445
DAMAGED	1,560.4	5.886	7.894	2.009F	0.66S	62.361

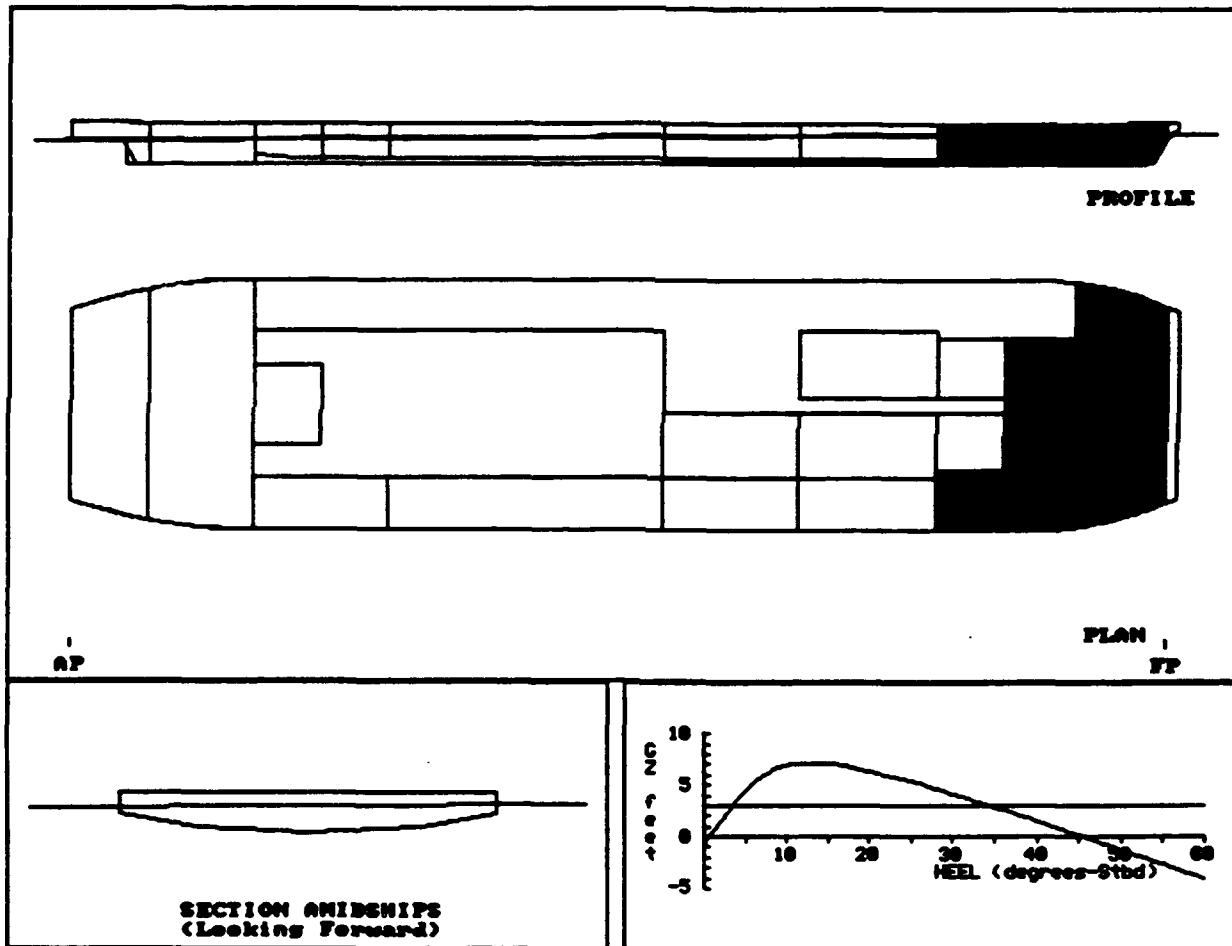

DPTA002A: DPRTA2
 192' FERRY

COMPARTMENT FLOODING SUMMARY

At 0.7oS Heel	PERM.	FLOODED WTR LTons	% FULL (Damaged)	% FULL (Intact)	SP.VOL. ft ³ /LT	OUTFLOW LTons
VOID1	0.95	62.8	FREE	0.0	----	----
BALLAST1	0.95	45.1	FREE	0.0	----	----
BOWTHRUST	0.95	69.6	FREE	0.0	----	----
Totals		177.5				

INTACT DATA

Draft at AP = 6.750 ft Kmt = 91.785 ft LCG = 95.090A ft-FP
 Draft at FP = 6.010 ft VCG = 17.340 ft LCB = 95.142A ft-FP
 Displacement = 1382.9 LTons GMT = 74.445 ft TCG = 0.000 ft-CL

DRAFT/GZ DATA

HEEL degrees	RIGHTING ARM ft	DRAFT AFT ft	DRAFT FWD ft	FLOODED WATER LTons
0.00	-0.728	5.959	7.824	172.3
7.00S	5.818	5.105	8.650	229.5
10.00S	6.900	4.436	9.334	240.4
15.00S	7.083	3.298	10.867	252.9
20.00S	6.414	2.069	12.734	261.6
30.00S	4.191	-0.768	17.284	273.0
40.00S	1.535	-4.458	23.246	280.5
50.00S	-1.251	-9.635	31.530	286.1
60.00S	-4.018	-17.527	44.188	290.0

Note: Drafts are measured at A.P. and F.P along ship's centerline

GZ SUMMARY (Evaluated per IMO (SOLAS'90) Rules for Passenger Ships)
 Available Required

Static Heel Angle	0.66S deg	7.00 deg
Angle at Maximum GZ	14.00S deg	
Maximum GZ	7.169 ft	3.000 ft
Range of Positive GZ	44.86 deg	15.00 deg
Righting Area (0.66-4.00)	121.385 ft-deg	2.820 ft-deg

DPTA003A:
 192' FERRY

aged Compartments:
 BALLAST

	DISPLACEMENT LTons	DRAFT AFT ft	DRAFT FWD ft	TRIM ft	HEEL deg.	UPRIGHT GMT ft
INTACT	1,382.9	6.750	6.010	0.740A	0.00	74.445
DAMAGED	1,414.7	6.626	6.320	0.305A	0.43S	68.617

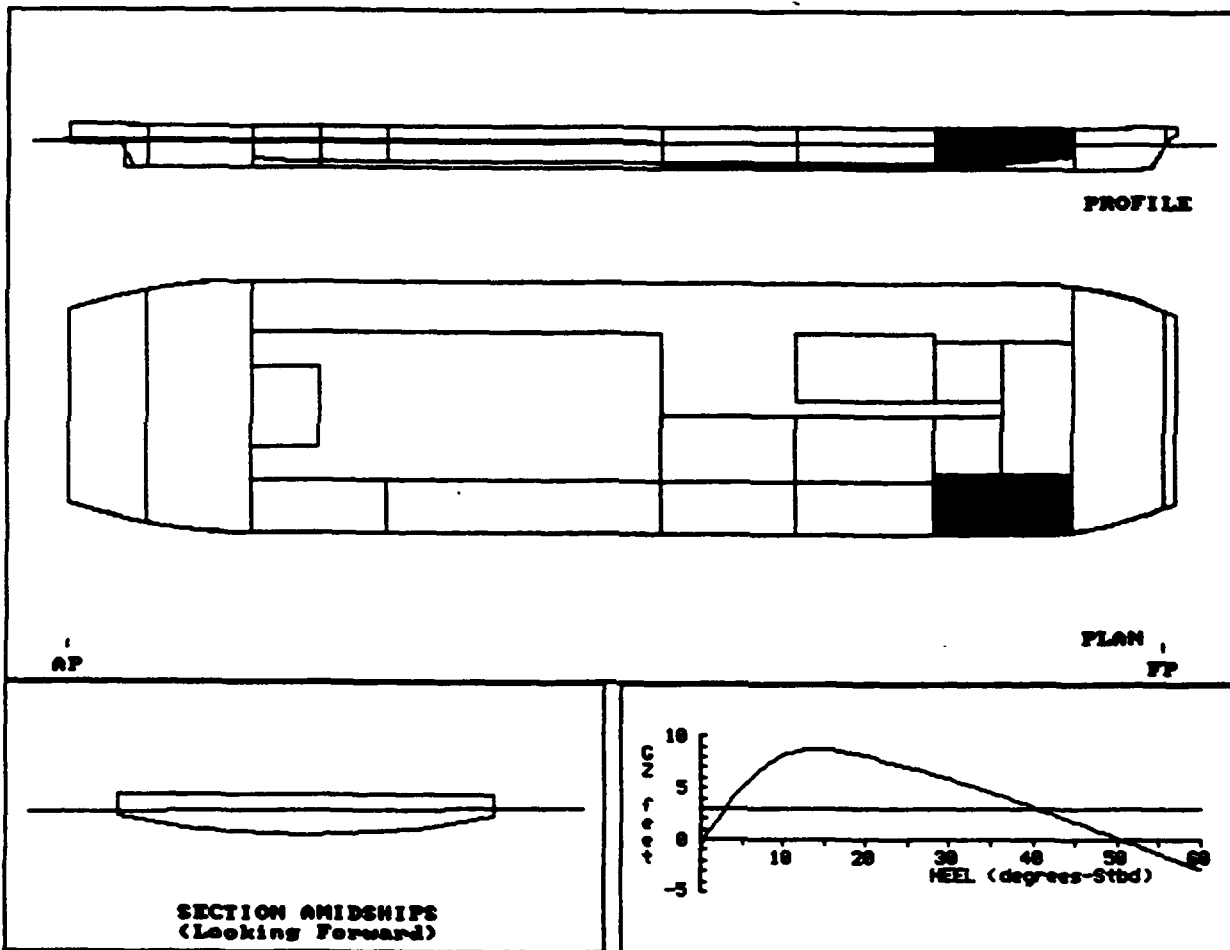

DPTA004A:
 192' FERRY

Managed Compartments:
 BALLAST2 BALLAST1

	DISPLACEMENT LTons	DRAFT AFT ft	DRAFT FWD ft	TRIM ft	HEEL deg.	UPRIGHT GMt ft
INTACT	1,382.9	6.750	6.010	0.740A	0.00	74.445
DAMAGED	1,452.8	6.539	6.623	0.084F	0.97S	63.895

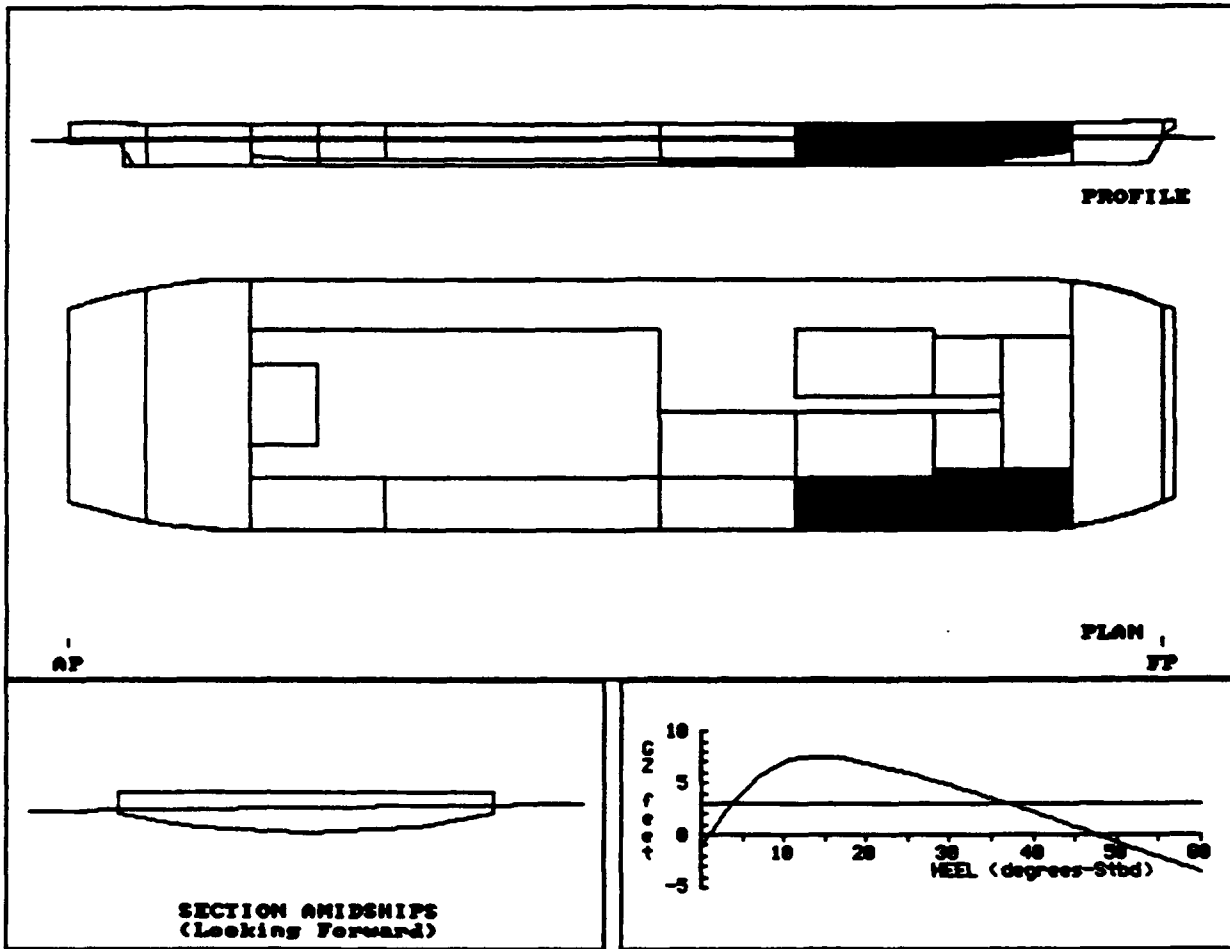

DPTA004A:
 192' FERRY

COMPARTMENT FLOODING SUMMARY

At 1.0oS Heel	PERM.	FLOODED WTR LTons	% FULL (Damaged)	% FULL (Intact)	SP.VOL. ft ³ /LT	OUTFLOW LTons
BALLAST2	0.95	33.3	FREE	0.0	----	----
BALLAST1	0.95	36.6	FREE	0.0	----	----
Totals		69.9				

INTACT DATA

Draft at AP = 6.750 ft	Kmt = 91.785 ft	LCG = 95.090A ft-FP
Draft at FP = 6.010 ft	VCG = 17.340 ft	LCB = 95.142A ft-FP
Displacement = 1382.9 LTons	Gmt = 74.445 ft	TCG = 0.000 ft-CL

DRAFT/GZ DATA

HEEL degrees	RIGHTING ARM ft	DRAFT AFT ft	DRAFT FWD ft	FLOODED WATER LTons
0.00	-1.072	6.580	6.548	60.8
5.00S	4.073	6.316	6.917	107.4
7.00S	5.595	6.068	7.010	124.4
10.00S	6.955	5.687	7.154	135.1
20.00S	6.912	4.852	7.964	135.9
30.00S	4.792	4.005	9.165	135.9
40.00S	2.160	2.989	10.735	135.9
50.00S	-0.653	1.635	12.922	135.9
60.00S	-3.488	-0.269	16.200	135.9

Note: Drafts are measured at A.P. and F.P along ship's centerline

GZ SUMMARY (Evaluated per IMO (SOLAS'90) Rules for Passenger Ships)
 Available Required

Static Heel Angle	0.97S deg	7.00 deg
Angle at Maximum GZ	15.00S deg	
Maximum GZ	7.536 ft	3.000 ft
Range of Positive GZ	46.73 deg	15.00 deg
Righting Area (0.97-1.00)	123.978 ft-deg	2.820 ft-deg

DPTA005A:
 192' FERRY

Damaged Compartments:
 BALLAST2

	DISPLACEMENT LTons	DRAFT AFT ft	DRAFT FWD ft	TRIM ft	HEEL deg.	UPRIGHT GMT ft
INTACT	1,382.9	6.750	6.010	0.740A	0.00	74.445
DAMAGED	1,411.8	6.702	6.223	0.479A	0.41S	68.966

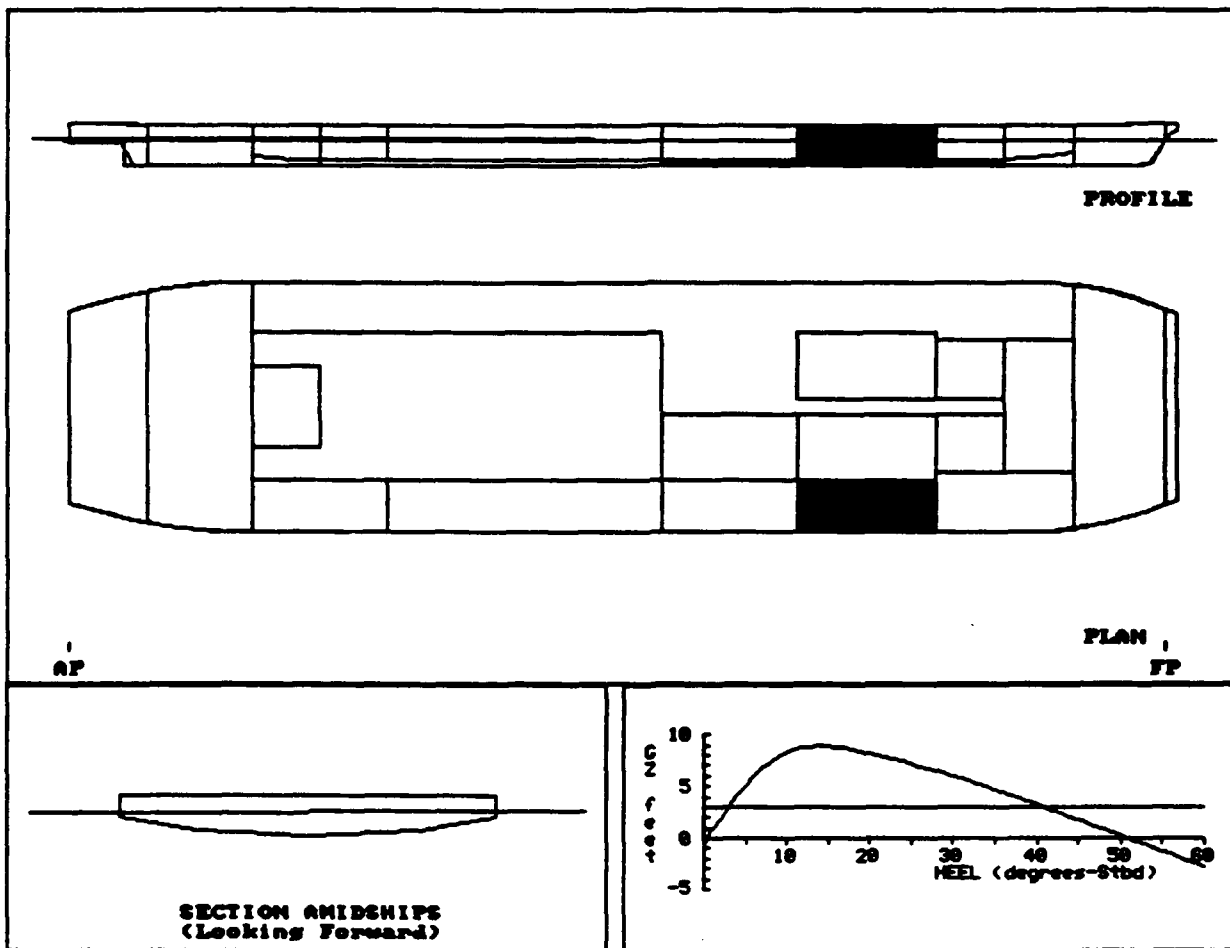

DPTA006A:
 192' FERRY

amaged Compartments:
 BALLAST2 BALLAST3

	DISPLACEMENT LTONS	DRAFT AFT ft	DRAFT FWD ft	TRIM ft	HEEL deg.	UPRIGHT GMT ft
INTACT	1,382.9	6.750	6.010	0.740A	0.00	74.445
DAMAGED	1,447.7	6.722	6.408	0.314A	0.92S	64.334

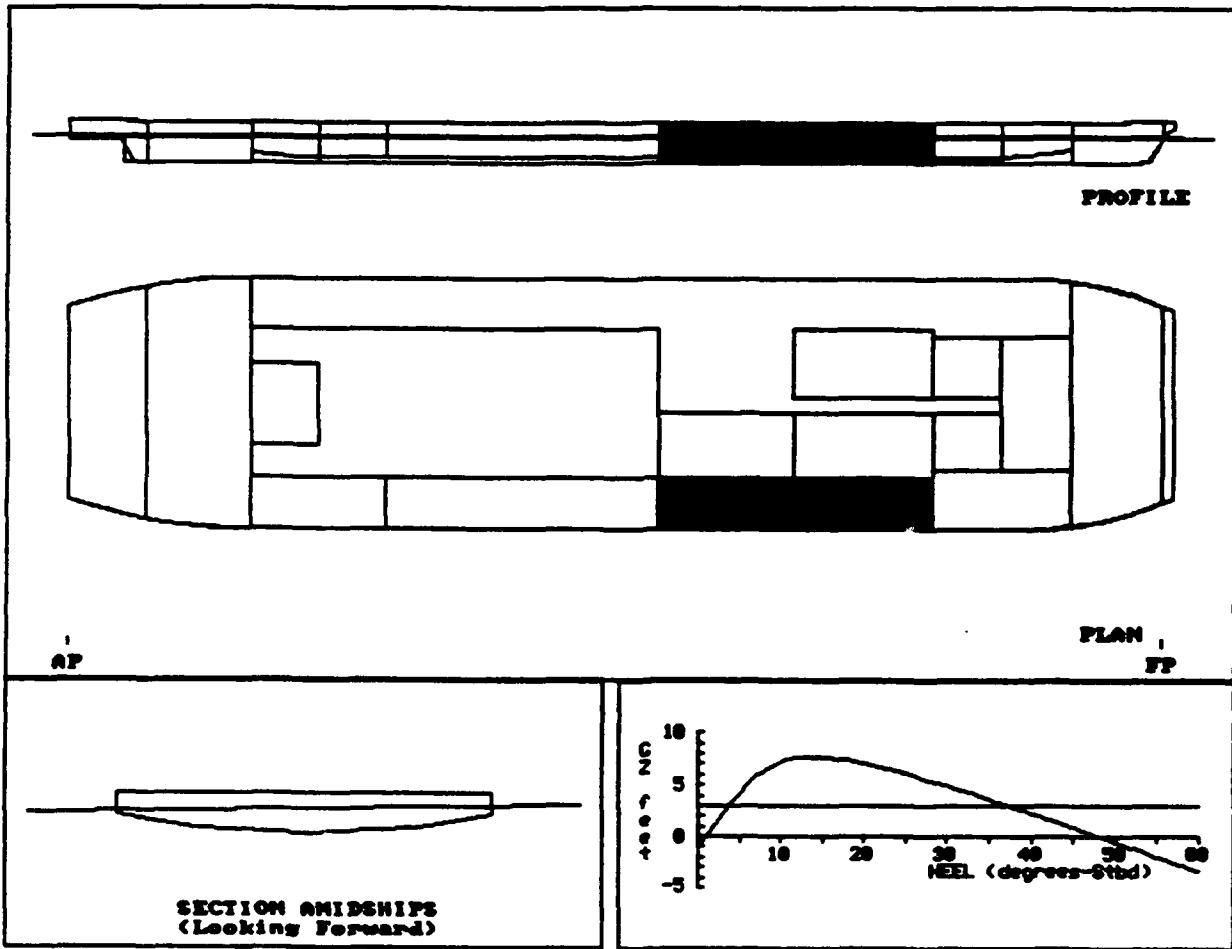

**DPTA006A:
 192' FERRY**

COMPARTMENT FLOODING SUMMARY

At 0.9oS Heel	PERM.	FLOODED WTR LTons	% FULL (Damaged)	% FULL (Intact)	SP.VOL. ft ³ /LT	OUTFLOW LTons
BALLAST2	0.95	32.2	FREE	0.0	----	----
BALLAST3	0.95	32.6	FREE	0.0	----	----
Totals		64.8				

INTACT DATA

Draft at AP = 6.750 ft KMT = 91.785 ft LCG = 95.090A ft-FP
 Draft at FP = 6.010 ft VCG = 17.340 ft LCB = 95.142A ft-FP
 Displacement = 1382.9 LTons GMT = 74.445 ft TCG = 0.000 ft-CL

DRAFT/GZ DATA

HEEL degrees	RIGHTING ARM ft	DRAFT AFT ft	DRAFT FWD ft	FLOODED WATER LTons
0.00	-1.029	6.735	6.365	56.9
5.00S	4.191	6.616	6.567	98.8
7.00S	5.742	6.449	6.573	114.1
10.00S	7.117	6.208	6.569	126.5
20.00S	7.081	5.875	6.846	128.1
30.00S	4.955	5.612	7.408	128.1
40.00S	2.310	5.329	8.172	128.1
50.00S	-0.523	4.962	9.260	128.1
60.00S	-3.387	4.439	10.950	128.1

Note: Drafts are measured at A.P. and F.P along ship's centerline

GZ SUMMARY (Evaluated per IMO (SOLAS'90) Rules for Passenger Ships)

	Available	Required
Static Heel Angle	0.92S deg	7.00 deg
Angle at Maximum GZ	15.00S deg	
Maximum GZ	7.704 ft	3.000 ft
Range of Positive GZ	47.25 deg	15.00 deg
Righting Area (0.92-8.00)	127.071 ft-deg	2.820 ft-deg

DPTA007A:
 192' FERRY

Damaged Compartments:
 BALLASTS

	DISPLACEMENT Ltons	DRAFT AFT ft	DRAFT FWD ft	TRIM ft	HEEL deg.	UPRIGHT GMT ft
INTACT	1,382.9	6.750	6.010	0.740A	0.00	74.445
DAMAGED	1,412.3	6.771	6.154	0.617A	0.42S	68.946

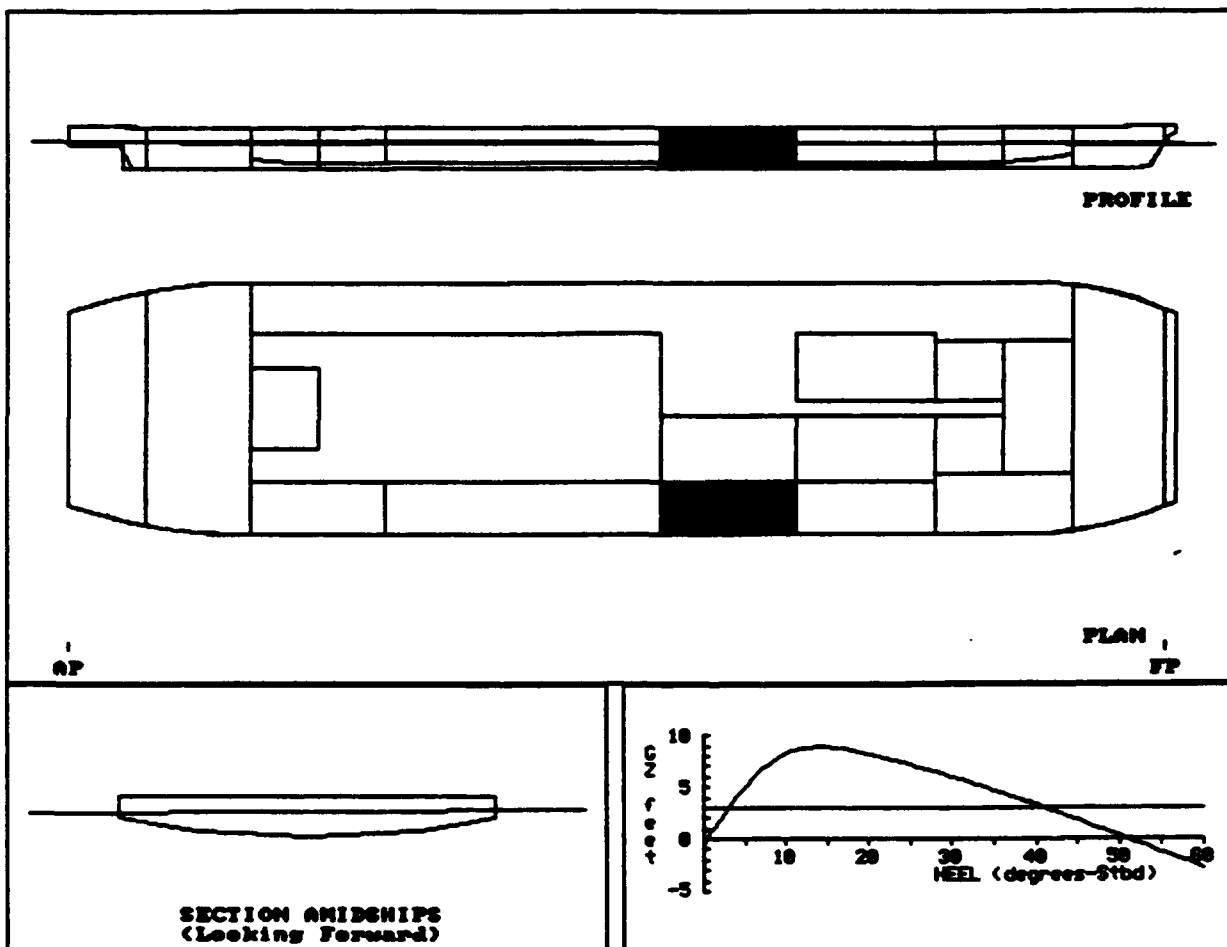

DPTA007A:
 192' FERRY

COMPARTMENT FLOODING SUMMARY

At 0.4oS Heel	PERM.	FLOODED WTR LTons	% FULL (Damaged)	% FULL (Intact)	SP.VOL. ft3/LT	OUTFLOW LTons
BALLAST3	0.95	29.4	FREE	0.0	----	----
Totals		29.4				

INTACT DATA

Draft at AP = 6.750 ft KMT = 91.785 ft LCG = 95.090A ft-FP
 Draft at FP = 6.010 ft VCG = 17.340 ft LCB = 95.142A ft-FP
 Displacement = 1382.9 LTons GMT = 74.445 ft TCG = 0.000 ft-CL

DRAFT/GZ DATA

HEEL degrees	RIGHTING ARM ft	DRAFT AFT ft	DRAFT FWD ft	FLOODED WATER LTons
0.00	-0.499	6.773	6.151	27.6
5.00S	5.037	6.702	6.158	47.5
7.00S	6.661	6.559	6.074	54.7
10.00S	8.198	6.371	5.887	62.1
20.00S	8.224	6.160	5.611	64.1
30.00S	6.033	6.111	5.473	64.1
40.00S	3.280	6.080	5.394	64.1
50.00S	0.304	6.050	5.348	64.1
60.00S	-2.731	6.011	5.333	64.1

Note: Drafts are measured at A.P. and F.P along ship's centerline

GZ SUMMARY (Evaluated per IMO (SOLAS'90) Rules for Passenger Ships)
 Available Required

Static Heel Angle	0.42S deg	7.00 deg
Angle at Maximum GZ	15.00S deg	
Maximum GZ	8.887 ft	3.000 ft
Range of Positive GZ	50.59 deg	15.00 deg
Righting Area (0.42-3.00)	148.861 ft-deg	2.820 ft-deg

DPTA008A:
192' FERRY

Managed Compartments:
BALLAST3 BALLAST4

	DISPLACEMENT LTons	DRAFT AFT ft	DRAFT FWD ft	TRIM ft	HEEL deg.	UPRIGHT GMT ft
INTACT	1,382.9	6.750	6.010	0.740A	0.00	74.445
DAMAGED	1,494.0	7.109	6.279	0.830A	1.58S	59.297

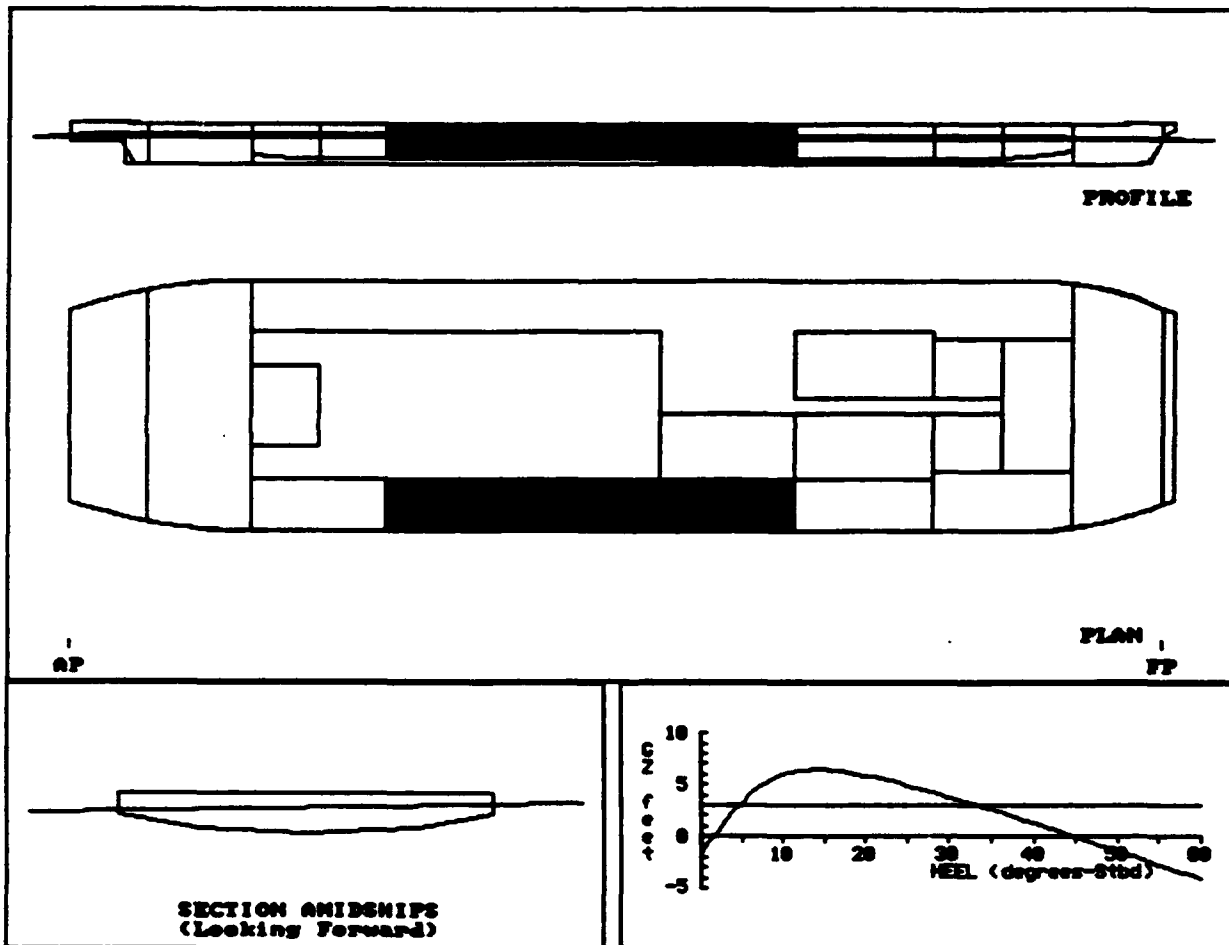

DPTA008A:
 192' FERRY

COMPARTMENT FLOODING SUMMARY

At 1.6oS Heel	PERM.	FLOODED WTR LTons	% FULL (Damaged)	% FULL (Intact)	SP.VOL. ft ³ /LT	OUTFLOW LTons
BALLAST3	0.95	35.9	FREE	0.0	----	----
BALLAST4	0.95	75.2	FREE	0.0	----	----
Totals		111.1				

INTACT DATA

Draft at AP = 6.750 ft KMT = 91.785 ft LCG = 95.090A ft-FP
 Draft at FP = 6.010 ft VCG = 17.340 ft LCB = 95.142A ft-FP
 Displacement = 1382.9 LTons GMT = 74.445 ft TCG = 0.000 ft-CL

DRAFT/GZ DATA

HEEL degrees	RIGHTING ARM ft	DRAFT AFT ft	DRAFT FWD ft	FLOODED WATER LTons
0.00	-1.640	7.039	6.247	90.5
5.00S	3.265	7.220	6.310	154.5
7.00S	4.729	7.212	6.241	177.5
10.00S	5.958	7.276	6.088	192.5
20.00S	5.870	7.882	5.913	193.5
30.00S	3.824	8.823	5.861	193.5
40.00S	1.301	10.014	5.886	193.5
50.00S	-1.374	11.638	5.970	193.5
60.00S	-4.051	14.114	6.167	193.5

Note: Drafts are measured at A.P. and F.P along ship's centerline

GZ SUMMARY (Evaluated per IMO (SOLAS'90) Rules for Passenger Ships)
 Available Required

Static Heel Angle	1.58S deg	7.00 deg
Angle at Maximum GZ	15.00S deg	
Maximum GZ	6.458 ft	3.000 ft
Range of Positive GZ	43.30 deg	15.00 deg
Righting Area (1.58-15.00)	104.095 ft-deg	2.820 ft-deg

DPTA009A:
 192' FERRY

aged Compartments:
 BALLAST

	DISPLACEMENT LTons	DRAFT AFT ft	DRAFT FWD ft	TRIM ft	HEEL deg.	UPRIGHT GMT ft
INTACT	1,382.9	6.750	6.010	0.740A	0.00	74.445
DAMAGED	1,451.2	7.046	6.091	0.955A	0.97S	64.008

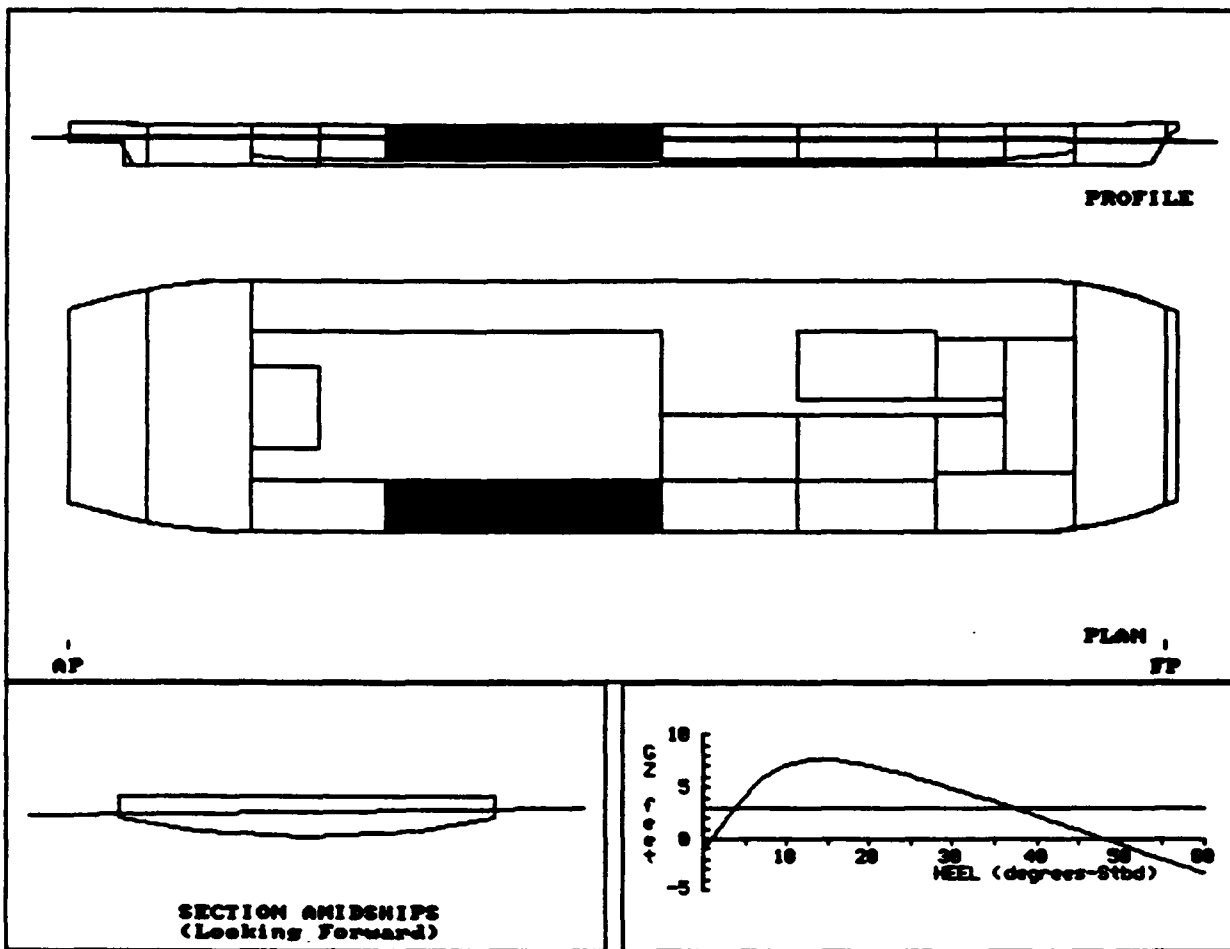

DPTA009A:
 192' FERRY

COMPARTMENT FLOODING SUMMARY

At 1.0oS Heel	PERM.	FLOODED WTR LTons	% FULL (Damaged)	% FULL (Intact)	SP.VOL. ft3/LT	OUTFLOW LTons
BALLAST4	0.95	68.3	FREE	0.0	----	----
Totals		68.3				

INTACT DATA

Draft at AP = 6.750 ft KMT = 91.785 ft LCG = 95.090A ft-FP
 Draft at FP = 6.010 ft VCG = 17.340 ft LCB = 95.142A ft-FP
 Displacement = 1382.9 LTons GMT = 74.445 ft TCG = 0.000 ft-CL

DRAFT/GZ DATA

HEEL degrees	RIGHTING ARM ft	DRAFT AFT ft	DRAFT FWD ft	FLOODED WATER LTons
0.00	-1.087	7.008	6.097	60.0
5.00S	4.141	7.166	6.031	101.8
7.00S	5.689	7.142	5.907	116.9
10.00S	7.062	7.180	5.646	128.2
20.00S	7.034	7.717	5.108	129.5
30.00S	4.916	8.581	4.638	129.5
40.00S	2.281	9.670	4.157	129.5
50.00S	-0.540	11.153	3.569	129.5
60.00S	-3.393	13.401	2.752	129.5

Note: Drafts are measured at A.P. and F.P along ship's centerline

GZ SUMMARY (Evaluated per IMO (SOLAS'90) Rules for Passenger Ships)
 Available Required

Static Heel Angle	0.97S deg	7.00 deg
Angle at Maximum GZ	15.00S deg	
Maximum GZ	7.651 ft	3.000 ft
Range of Positive GZ	47.13 deg	15.00 deg
Righting Area (0.97-1.00)	125.975 ft-deg	2.820 ft-deg

DPTA010A:
 192' FERRY

Damaged Compartments:

BALLAST4 BALLAST5

	DISPLACEMENT LTons	DRAFT AFT ft	DRAFT FWD ft	TRIM ft	HEEL deg.	UPRIGHT GMT ft
INTACT	1,382.9	6.750	6.010	0.740A	0.00	74.445
DAMAGED	1,499.2	7.397	6.008	1.389A	1.66S	58.638

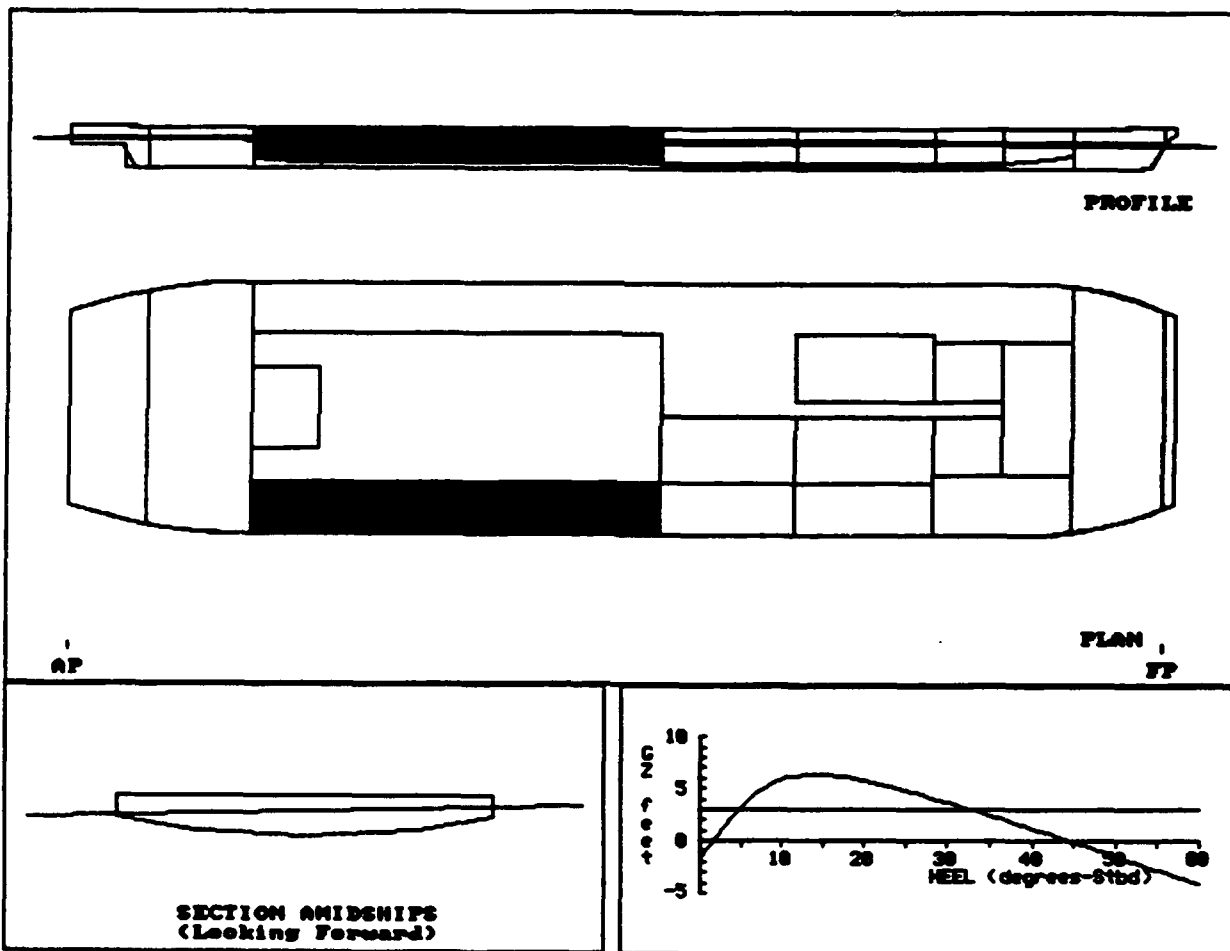

DPTA011A:
 192' FERRY

aged Compartments:
 BALLASTS

	DISPLACEMENT LTons	DRAFT AFT ft	DRAFT FWD ft	TRIM ft	HEEL deg.	UPRIGHT GMT ft
INTACT	1,382.9	6.750	6.010	0.740A	0.00	74.445
DAMAGED	1,414.7	6.998	5.930	1.068A	0.46S	68.513

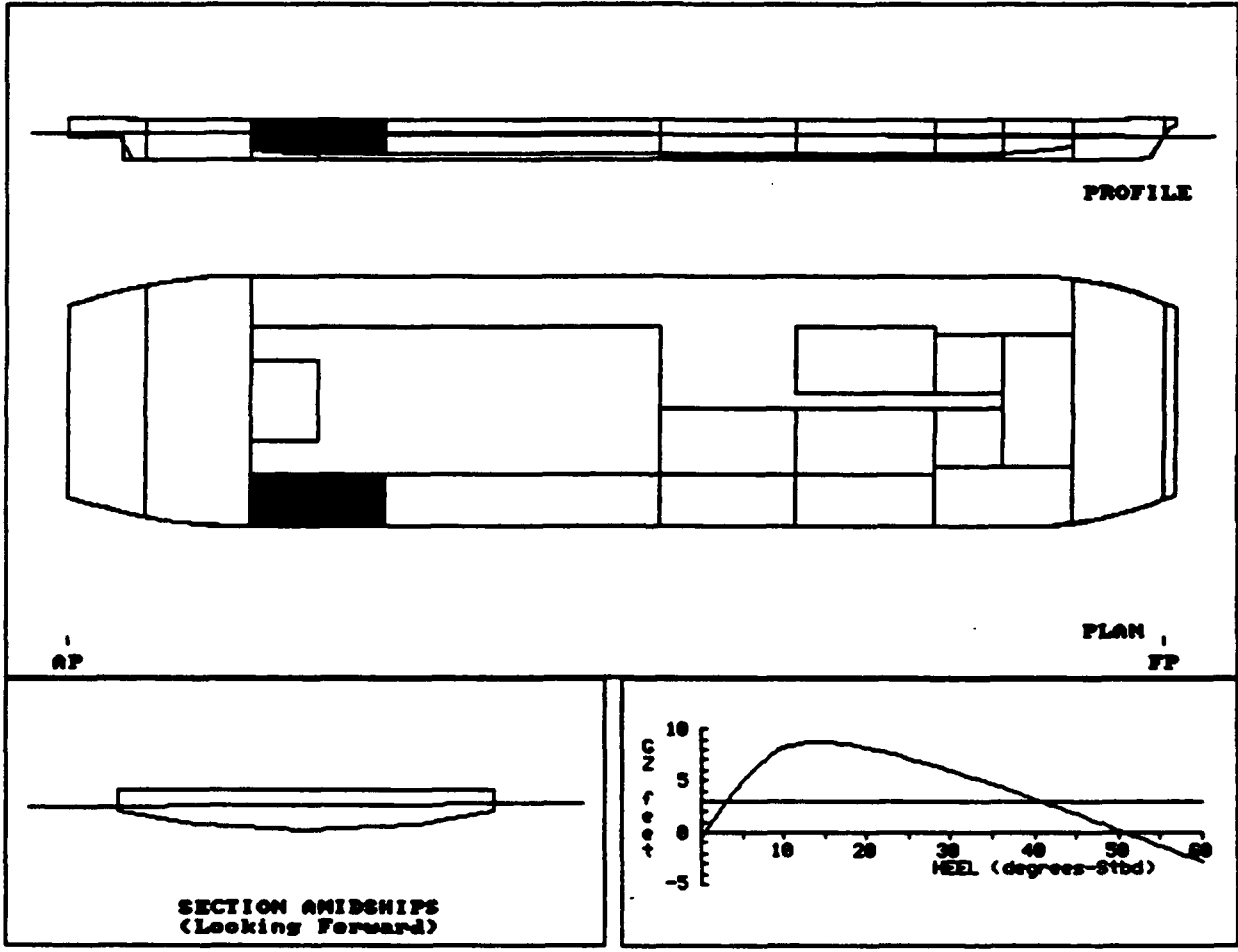

DPTA011A:
 192' FERRY

COMPARTMENT FLOODING SUMMARY

At 0.5oS Heel	PERM.	FLOODED WTR LTons	% FULL (Damaged)	% FULL (Intact)	SP.VOL. ft3/LT	OUTFLOW LTons
BALLAST5	0.95	31.8	FREE	0.0	----	----
Totals		31.8				

INTACT DATA

Draft at AP = 6.750 ft	Kmt = 91.785 ft	LCG = 95.090A ft-FP
Draft at FP = 6.010 ft	VCG = 17.340 ft	LCB = 95.142A ft-FP
Displacement = 1382.9 LTons	GMT = 74.445 ft	TCG = 0.000 ft-CL

DRAFT/GZ DATA

HEEL degrees	RIGHTING ARM ft	DRAFT AFT ft	DRAFT FWD ft	FLOODED WATER LTons
0.00	-0.543	6.982	5.945	29.9
5.00S	4.983	7.120	5.750	50.3
7.00S	6.605	7.081	5.569	57.6
10.00S	8.137	7.066	5.224	62.5
20.00S	8.178	7.530	4.309	62.9
30.00S	5.999	8.256	3.459	62.9
40.00S	3.255	9.206	2.492	62.9
50.00S	0.289	10.503	1.252	62.9
60.00S	-2.735	12.500	-0.595	62.9

Note: Drafts are measured at A.P. and F.P along ship's centerline

GZ SUMMARY (Evaluated per IMO (SOLAS'90) Rules for Passenger Ships)
 Available Required

Static Heel Angle	0.46S deg	7.00 deg
Angle at Maximum GZ	15.00S deg	
Maximum GZ	8.828 ft	3.000 ft
Range of Positive GZ	50.51 deg	15.00 deg
Righting Area (0.46-7.00)	147.691 ft-deg	2.820 ft-deg

DPTA012A:
 192' FERRY

Damaged Compartments:
 BALLASTS VOIDS

	DISPLACEMENT LTons	DRAFT AFT ft	DRAFT FWD ft	TRIM ft	HEEL deg.	UPRIGHT GMT ft
INTACT	1,382.9	6.750	6.010	0.740A	0.00	74.445
DAMAGED	1,551.6	8.336	5.328	3.008A	0.66S	59.633

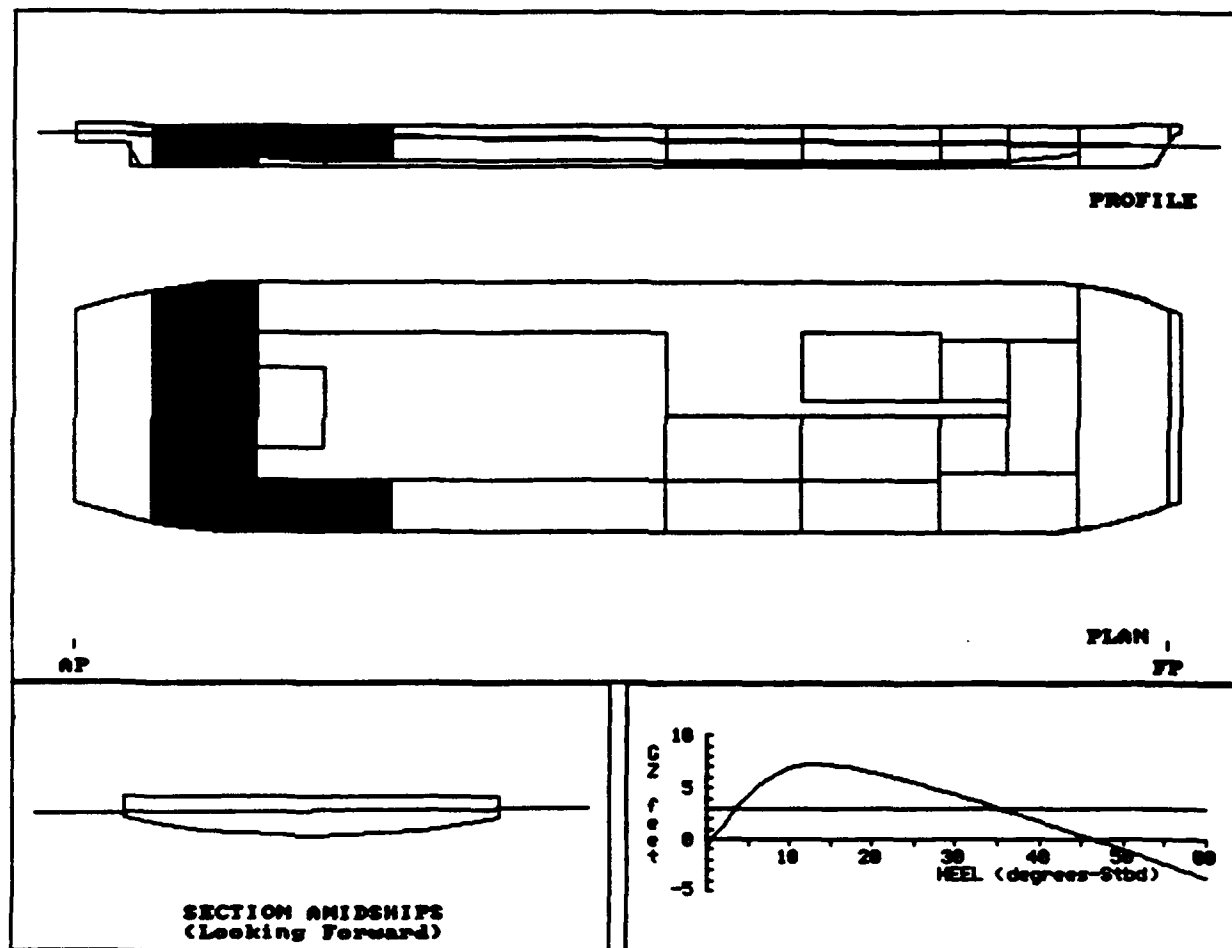

DPTA012A:
 192' FERRY

COMPARTMENT FLOODING SUMMARY

At 0.7oS Heel	PERM.	FLOODED WTR LTons	% FULL (Damaged)	% FULL (Intact)	SP.VOL. ft ³ /LT	OUTFLOW LTons
BALLAST5	0.95	40.3	FREE	0.0	----	----
VOID3	0.95	128.3	FREE	0.0	----	----
Totals		168.7				

INTACT DATA

Draft at AP = 6.750 ft KMT = 91.785 ft LCG = 95.090A ft-FP
 Draft at FP = 6.010 ft VCG = 17.340 ft LCB = 95.142A ft-FP
 Displacement = 1382.9 LTons GMT = 74.445 ft TCG = 0.000 ft-CL

DRAFT/GZ DATA

HEEL degrees	RIGHTING ARM ft	DRAFT AFT ft	DRAFT FWD ft	FLOODED WATER LTons
0.00	-0.688	8.296	5.358	165.1
5.00S	4.236	8.622	5.067	194.1
7.00S	5.668	8.829	4.774	198.4
10.00S	6.851	9.302	4.241	199.5
20.00S	6.564	11.871	2.390	205.4
30.00S	4.421	15.286	0.309	209.3
40.00S	1.798	19.781	-2.384	212.4
50.00S	-0.977	25.972	-6.098	214.7
60.00S	-3.757	35.468	-11.791	216.4

Note: Drafts are measured at A.P. and F.P along ship's centerline

GZ SUMMARY (Evaluated per IMO (SOLAS'90) Rules for Passenger Ships)

	Available	Required
Static Heel Angle	0.66S deg	7.00 deg
Angle at Maximum GZ	15.00S deg	
Maximum GZ	7.272 ft	3.000 ft
Range of Positive GZ	45.84 deg	15.00 deg
Righting Area (0.66-%.00)	121.812 ft-deg	2.820 ft-deg

DPTA013A:
192' FERRY

Damaged Compartments:
 VOID3 VOID4

	DISPLACEMENT LTons	DRAFT AFT ft	DRAFT FWD ft	TRIM ft	HEEL deg.	UPRIGHT GMT ft
INTACT	1,382.9	6.750	6.010	0.740A	0.00	74.445
DAMAGED	1,579.2	8.777	5.029	3.747A	0.00	59.835

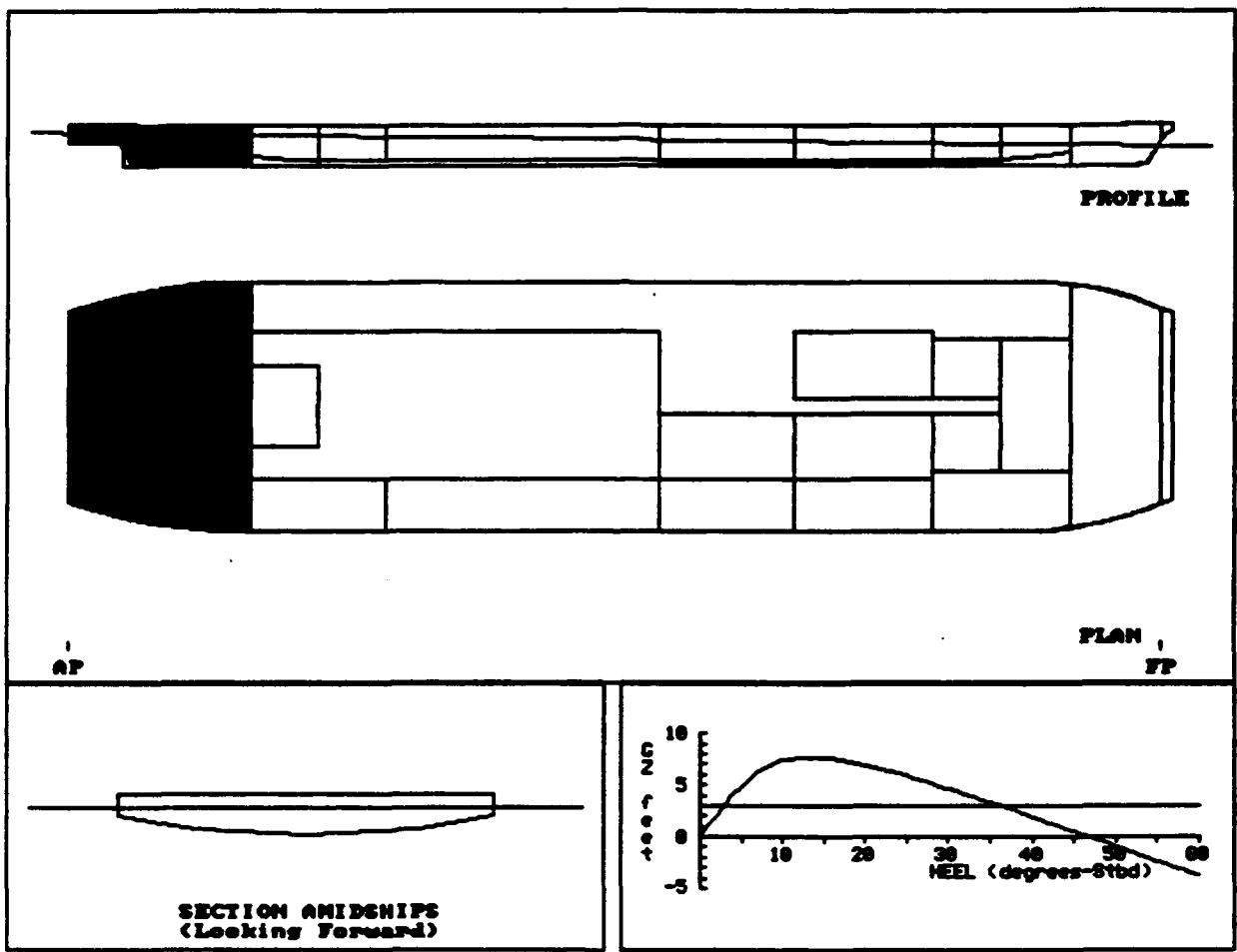

DPTA013A:
 192' FERRY

COMPARTMENT FLOODING SUMMARY

At 0.0o Heel	PERM.	FLOODED WTR LTons	% FULL (Damaged)	% FULL (Intact)	SP.VOL. ft3/LT	OUTFLOW LTons
VOID3	0.95	139.9	FREE	0.0	----	----
VOID4	0.95	56.5	FREE	0.0	----	----
Totals		196.3				

INTACT DATA

Draft at AP = 6.750 ft	KMT = 91.785 ft	LCG = 95.090A ft-FP
Draft at FP = 6.010 ft	VCG = 17.340 ft	LCB = 95.142A ft-FP
Displacement = 1382.9 LTons	GMT = 74.445 ft	TCG = 0.000 ft-CL

DRAFT/GZ DATA

HEEL degrees	RIGHTING ARM ft	DRAFT AFT ft	DRAFT FWD ft	FLOODED WATER LTons
0.00	0.000	8.777	5.029	196.3
5.00S	4.923	8.952	4.755	201.8
7.00S	6.290	9.182	4.447	202.3
10.00S	7.369	9.825	3.823	207.3
20.00S	6.930	13.281	1.422	225.7
30.00S	4.680	18.012	-1.515	237.8
40.00S	1.962	24.311	-5.421	246.7
50.00S	-0.903	33.172	-10.957	253.8
60.00S	-3.753	46.685	-19.388	259.0

Note: Drafts are measured at A.P. and F.P along ship's centerline

GZ SUMMARY (Evaluated per IMO (SOLAS'90) Rules for Passenger Ships)

	Available	Required
Static Heel Angle	0.00 deg	7.00 deg
Angle at Maximum GZ	14.00S deg	
Maximum GZ	7.705 ft	3.000 ft
Range of Positive GZ	46.86 deg	15.00 deg
Gmt (upright damaged)	59.835 ft	
Righting Area (0.00-%.00)	133.059 ft-deg	2.820 ft-deg

DFTA014A:
 192' FERRY

Damaged Compartments:

	VOID1	BALLAST1	BOATHRUST	FO #1 S			
	DISPLACEMENT	DRAFT AFT	DRAFT FWD	TRIM	HEEL	UPRIGHT	GMT
	Ltons	ft	ft	ft	deg.	ft	
INTACT	1,382.9	6.750	6.010	0.740A	0.00	74.445	
DAMAGED	1,546.3	5.959	7.759	1.800F	0.59S	63.902	

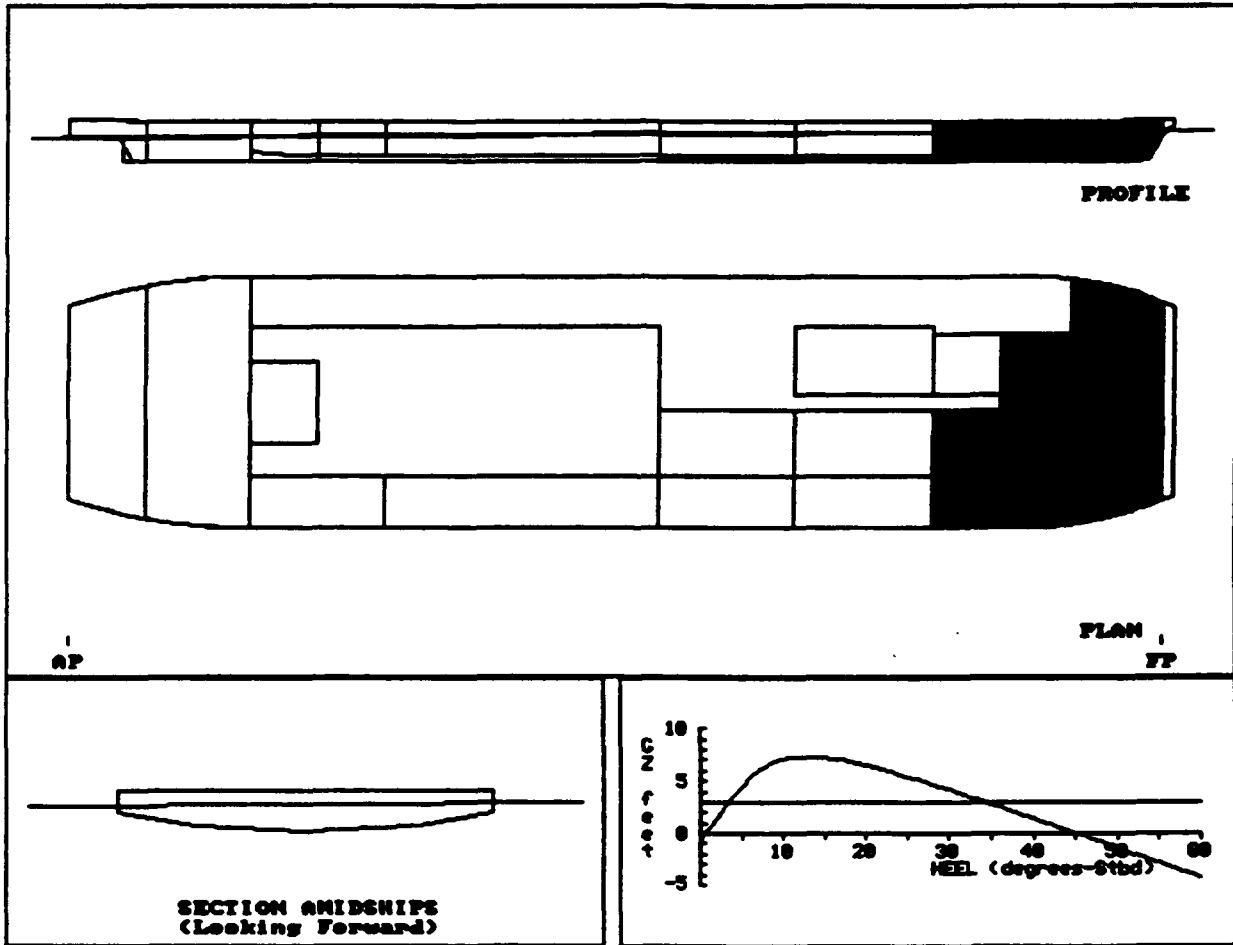

DPTA014A:
 192' FERRY

COMPARTMENT FLOODING SUMMARY

At 0.6oS Heel	PERM.	FLOODED WTR LTons	% FULL (Damaged)	% FULL (Intact)	SP.VOL. ft ³ /LT	OUTFLOW LTons
VOID1	0.95	59.8	FREE	0.0	----	----
BALLAST1	0.95	43.7	FREE	0.0	----	----
BOWTHRUST	0.95	68.4	FREE	0.0	----	----
FO #1 S	0.95	33.9	FREE	100.0	40.6000	42.4
Totals		205.8				42.4

INTACT DATA

Draft at AP = 6.750 ft KMT = 91.785 ft LCG = 95.090A ft-FP
 Draft at FP = 6.010 ft VCG = 17.340 ft LCB = 95.142A ft-FP
 Displacement = 1382.9 LTons GMT = 74.445 ft TCG = 0.000 ft-CL

DRAFT/GZ DATA

HEEL degrees	RIGHTING ARM ft	DRAFT AFT ft	DRAFT FWD ft	FLOODED WATER LTons
0.00	-0.663	6.013	7.687	200.0
5.00S	4.533	5.487	8.321	255.8
7.00S	5.985	5.091	8.672	272.6
10.00S	7.051	4.399	9.428	288.7
20.00S	6.502	1.941	13.021	313.4
30.00S	4.213	-0.962	17.714	324.6
40.00S	1.481	-4.752	23.870	332.1
50.00S	-1.383	-10.078	32.430	337.5
60.00S	-4.216	-18.108	45.402	341.1

Note: Drafts are measured at A.P. and F.P along ship's centerline

GZ SUMMARY (Evaluated per IMO (SOLAS'90) Rules for Passenger Ships)

	Available	Required
Static Heel Angle	0.59S deg	7.00 deg
Angle at Maximum GZ	14.00S deg	
Maximum GZ	7.343 ft	3.000 ft
Range of Positive GZ	44.58 deg	15.00 deg
Righting Area (0.59-14.00)	124.380 ft-deg	2.820 ft-deg

DFTA015A:
 192' FERRY

Damaged Compartments:

	BALLAST1	BOWTHRUST	FO #1 S	BALLAST2	FO #2 S		
	DISPLACEMENT		DRAFT AFT	DRAFT FWD	TRIM	HEEL	UPRIGHT GMT
	LTons		ft	ft	ft	deg.	ft
INTACT	1,382.9		6.750	6.010	0.740A	0.00	74.445
DAMAGED	1,481.1		6.326	7.007	0.681F	0.81S	67.190

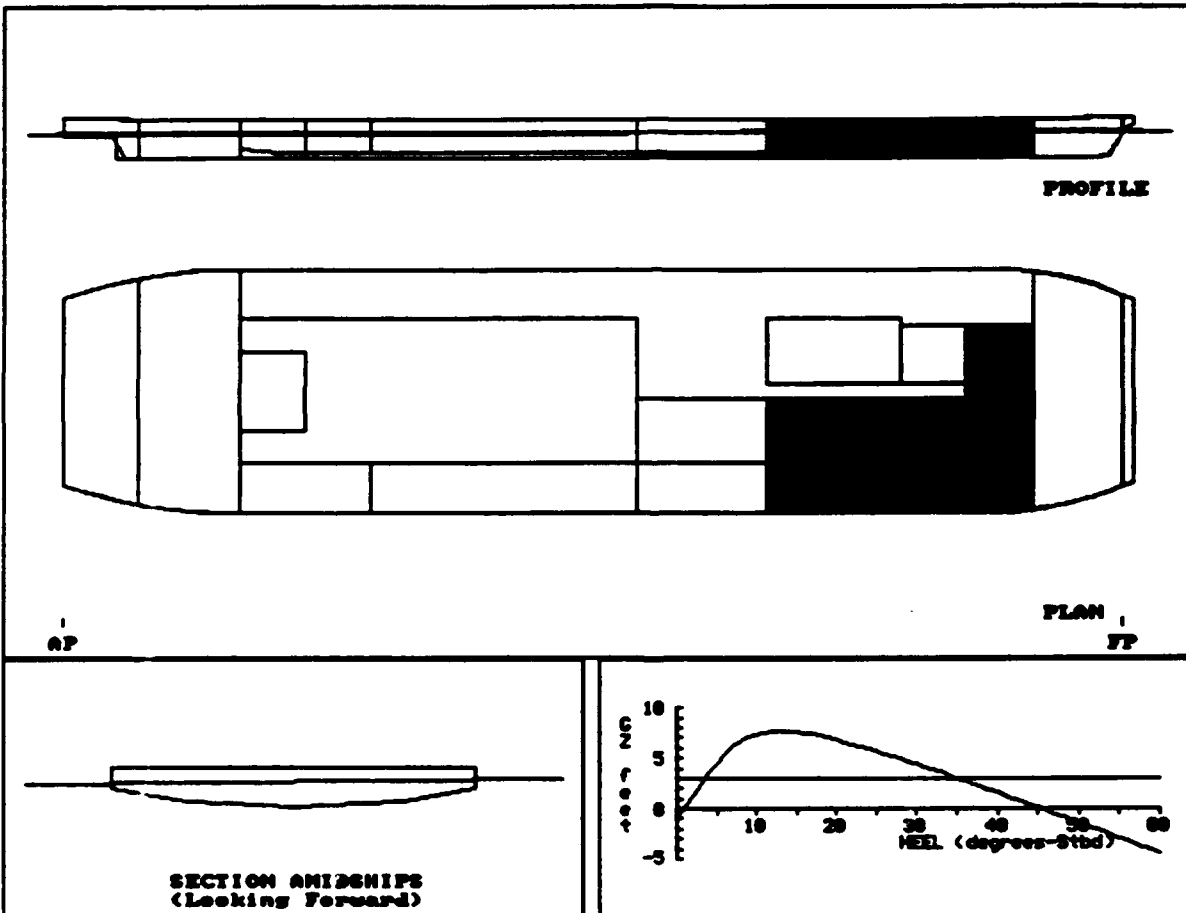

DPTA015A:
 192' FERRY

COMPARTMENT FLOODING SUMMARY

At 0.8oS Heel	PERM.	FLOODED WTR LTons	% FULL (Damaged)	% FULL (Intact)	SP.VOL. ft ³ /LT	OUTFLOW LTons
BALLAST1	0.95	38.8	FREE	0.0	----	----
BOWTHRUST	0.95	61.3	FREE	0.0	----	----
FO #1 S	0.95	31.3	FREE	100.0	40.6000	42.4
BALLAST2	0.95	34.6	FREE	0.0	----	----
FO #2 S	0.95	70.2	FREE	100.0	40.6000	95.7
Totals		236.2				138.0

INTACT DATA

Draft at AP = 6.750 ft KMT = 91.785 ft LCG = 95.090A ft-FP
 Draft at FP = 6.010 ft VCG = 17.340 ft LCB = 95.142A ft-FP
 Displacement = 1382.9 LTons GMT = 74.445 ft TCG = 0.000 ft-CL

DRAFT/GZ DATA

HEEL degrees	RIGHTING ARM ft	DRAFT AFT ft	DRAFT FWD ft	FLOODED WATER LTons
0.00	-0.941	6.383	6.893	223.4
5.00S	4.486	5.980	7.579	302.5
7.00S	6.081	5.681	7.821	327.9
10.00S	7.308	5.156	8.348	350.0
20.00S	6.816	3.528	10.872	376.5
30.00S	4.460	1.820	13.877	379.9
40.00S	1.604	-0.325	17.739	381.3
50.00S	-1.402	-3.184	22.992	382.3
60.00S	-4.411	-7.615	31.091	383.0

Note: Drafts are measured at A.P. and F.P along ship's centerline

GZ SUMMARY (Evaluated per IMO (SOLAS'90) Rules for Passenger Ships)
 Available Required

Static Heel Angle	0.81S deg	7.00 deg
Angle at Maximum GZ	14.00S deg	
Maximum GZ	7.673 ft	3.000 ft
Range of Positive GZ	44.54 deg	15.00 deg
Righting Area (0.81- 1.00)	128.172 ft-deg	2.820 ft-deg

DPTA016A:
 192' FERRY

Damaged Compartments:

	BALLAST2	PO #2 S	BALLAST3	VOID2			
	DISPLACEMENT	DRAFT AFT	DRAFT FWD	TRIM	HEEL	UPRIGHT	GMT
	LTons	ft	ft	ft	deg.	ft	
INTACT	1,382.9	6.750	6.010	0.740A	0.00	74.445	
DAMAGED	1,496.2	6.811	6.600	0.210A	1.24S	66.057	

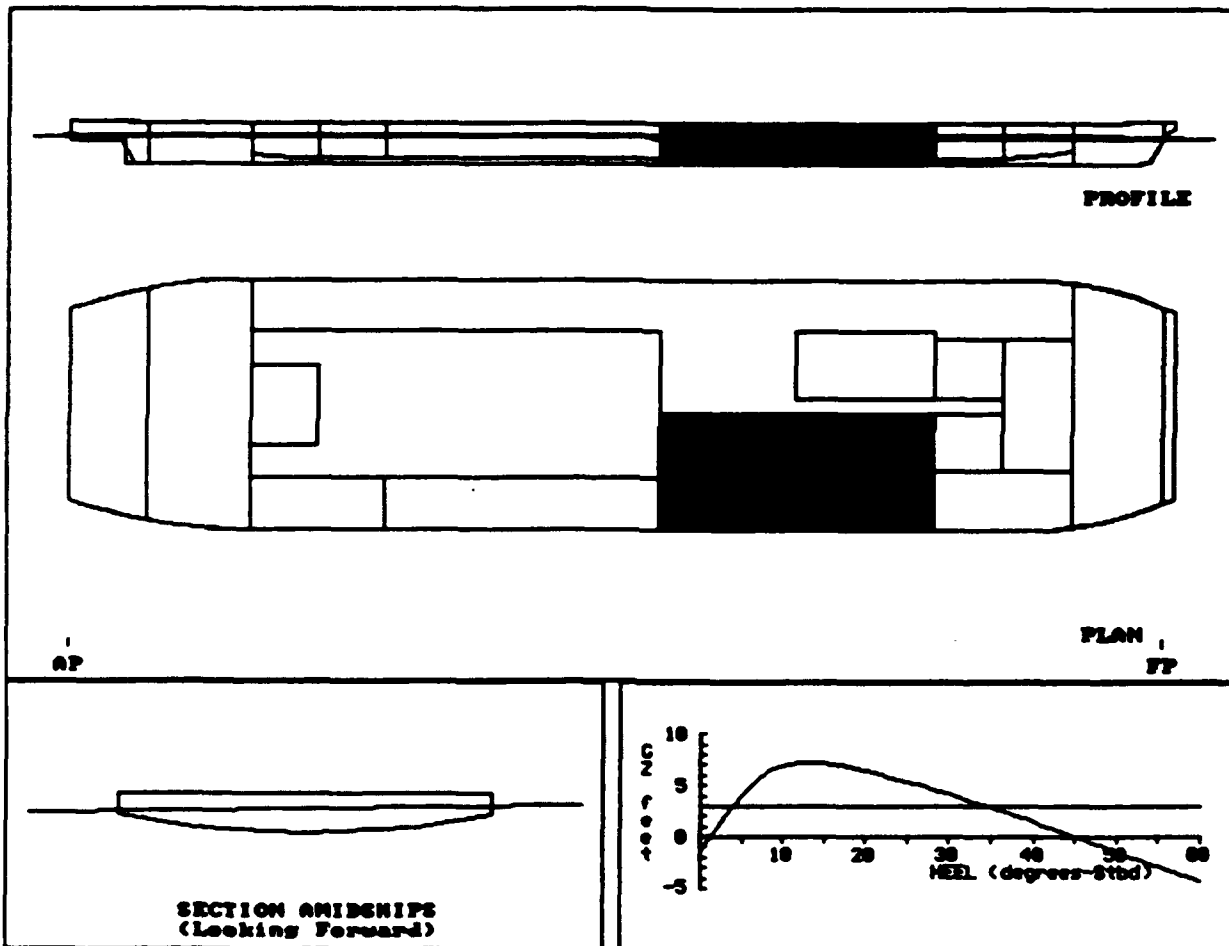

DPTA016A:
 192' FERRY

COMPARTMENT FLOODING SUMMARY

At 1.2oS Heel	PERM.	FLOODED WTR LTons	% FULL (Damaged)	% FULL (Intact)	SP.VOL. ft ³ /LT	OUTFLOW LTons
BALLAST2	0.95	34.9	FREE	0.0	----	----
FO #2 S	0.95	69.3	FREE	100.0	40.6000	95.7
BALLAST3	0.95	35.2	FREE	0.0	----	----
VOID2	0.95	69.6	FREE	0.0	----	----
Totals		209.0				95.7

INTACT DATA

Draft at AP = 6.750 ft Kmt = 91.785 ft LCG = 95.090A ft-FP
 Draft at FP = 6.010 ft VCG = 17.340 ft LCB = 95.142A ft-FP
 Displacement = 1382.9 LTons GMT = 74.445 ft TCG = 0.000 ft-CL

DRAFT/GZ DATA

HEEL degrees	RIGHTING ARM ft	DRAFT AFT ft	DRAFT FWD ft	FLOODED WATER LTons
0.00	-1.430	6.820	6.500	190.9
5.00S	4.029	6.726	6.876	261.4
7.00S	5.685	6.560	6.965	285.9
10.00S	6.935	6.353	7.167	309.7
20.00S	6.489	6.025	8.507	341.7
30.00S	4.219	5.796	10.188	349.4
40.00S	1.496	5.543	12.207	350.1
50.00S	-1.386	5.168	15.004	350.1
60.00S	-4.277	4.682	19.252	350.1

Note: Drafts are measured at A.P. and F.P along ship's centerline

GZ SUMMARY (Evaluated per IMO (SOLAS'90) Rules for Passenger Ships)
 Available Required

Static Heel Angle	1.24S deg	7.00 deg
Angle at Maximum GZ	14.00S deg	
Maximum GZ	7.307 ft	3.000 ft
Range of Positive GZ	43.97 deg	15.00 deg
Righting Area (1.24-3.00)	120.049 ft-deg	2.820 ft-deg

DPTA017A:
 192' FERRY

Damaged Compartments:

BALLAST3 VO102 BALLAST4

	DISPLACEMENT LTons	DRAFT AFT ft	DRAFT FWD ft	TRIM ft	HEEL deg.	UPRIGHT Gmt ft
INTACT	1,382.9	6.750	6.010	0.740A	0.00	74.445
DAMAGED	1,582.1	7.212	6.694	0.518A	2.20S	58.311

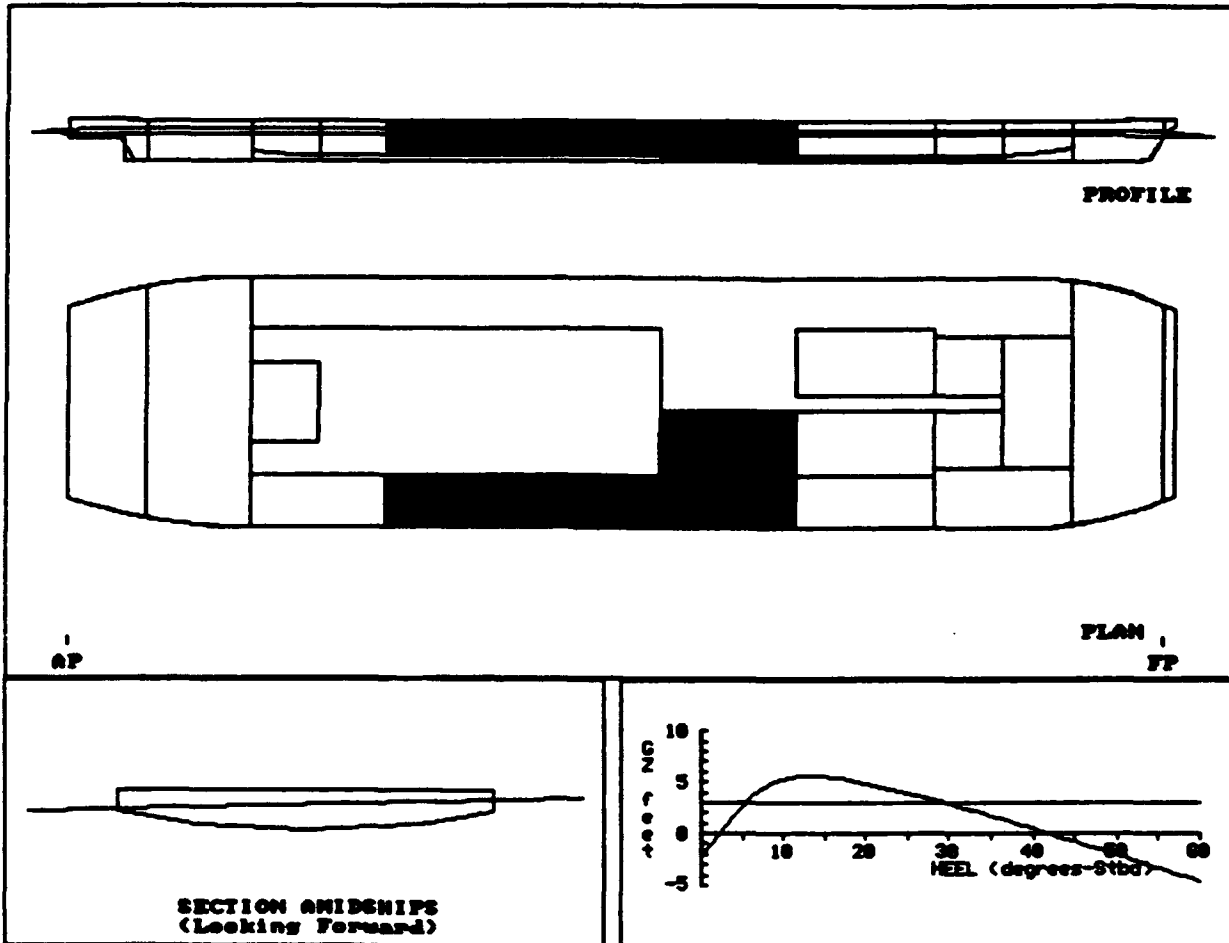

DPTA017A:
 192' FERRY

COMPARTMENT FLOODING SUMMARY

At 2.2oS Heel	PERM.	FLOODED WTR LTons	% FULL (Damaged)	% FULL (Intact)	SP.VOL. ft ³ /LT	OUTFLOW LTons
BALLAST3	0.95	40.9	FREE	0.0	----	----
VOID2	0.95	74.0	FREE	0.0	----	----
BALLAST4	0.95	84.3	FREE	0.0	----	----
Totals		199.2				

INTACT DATA

Draft at AP = 6.750 ft Kmt = 91.785 ft LCG = 95.090A ft-FP
 Draft at FP = 6.010 ft VCG = 17.340 ft LCB = 95.142A ft-FP
 Displacement = 1382.9 LTons GMT = 74.445 ft TCG = 0.000 ft-CL

DRAFT/GZ DATA

HEEL degrees	RIGHTING ARM ft	DRAFT AFT ft	DRAFT FWD ft	FLOODED WATER LTons
0.00	-2.258	7.100	6.613	164.2
5.00S	2.664	7.315	6.758	242.4
7.00S	4.151	7.326	6.737	268.7
10.00S	5.245	7.419	6.742	285.7
20.00S	4.923	8.150	7.278	300.1
30.00S	2.908	9.206	8.072	304.0
40.00S	0.486	10.547	9.051	304.5
50.00S	-2.058	12.373	10.404	304.5
60.00S	-4.590	15.176	12.522	304.5

Note: Drafts are measured at A.P. and F.P along ship's centerline

GZ SUMMARY (Evaluated per IMO (SOLAS'90) Rules for Passenger Ships)
 Available Required

Static Heel Angle	2.20S deg	7.00 deg
Angle at Maximum GZ	15.00S deg	
Maximum GZ	5.586 ft	3.000 ft
Range of Positive GZ	39.72 deg	15.00 deg
Righting Area (2.20-7.00)	88.457 ft-deg	2.820 ft-deg

DPTA018A:
 192' FERRY

Imaged Compartments:

	BALLAST3	VOID2	BALLAST4	ENG ROOM			
	DISPLACEMENT	DRAFT AFT	DRAFT FWD	TRIM	HEEL	UPRIGHT	GMT
	LTONS	ft	ft	ft	deg.	ft	
INTACT	1,382.9	6.750	6.010	0.740A	0.00	74.445	
DAMAGED	2,191.5	10.505	7.044	3.462A	4.00S	53.452	

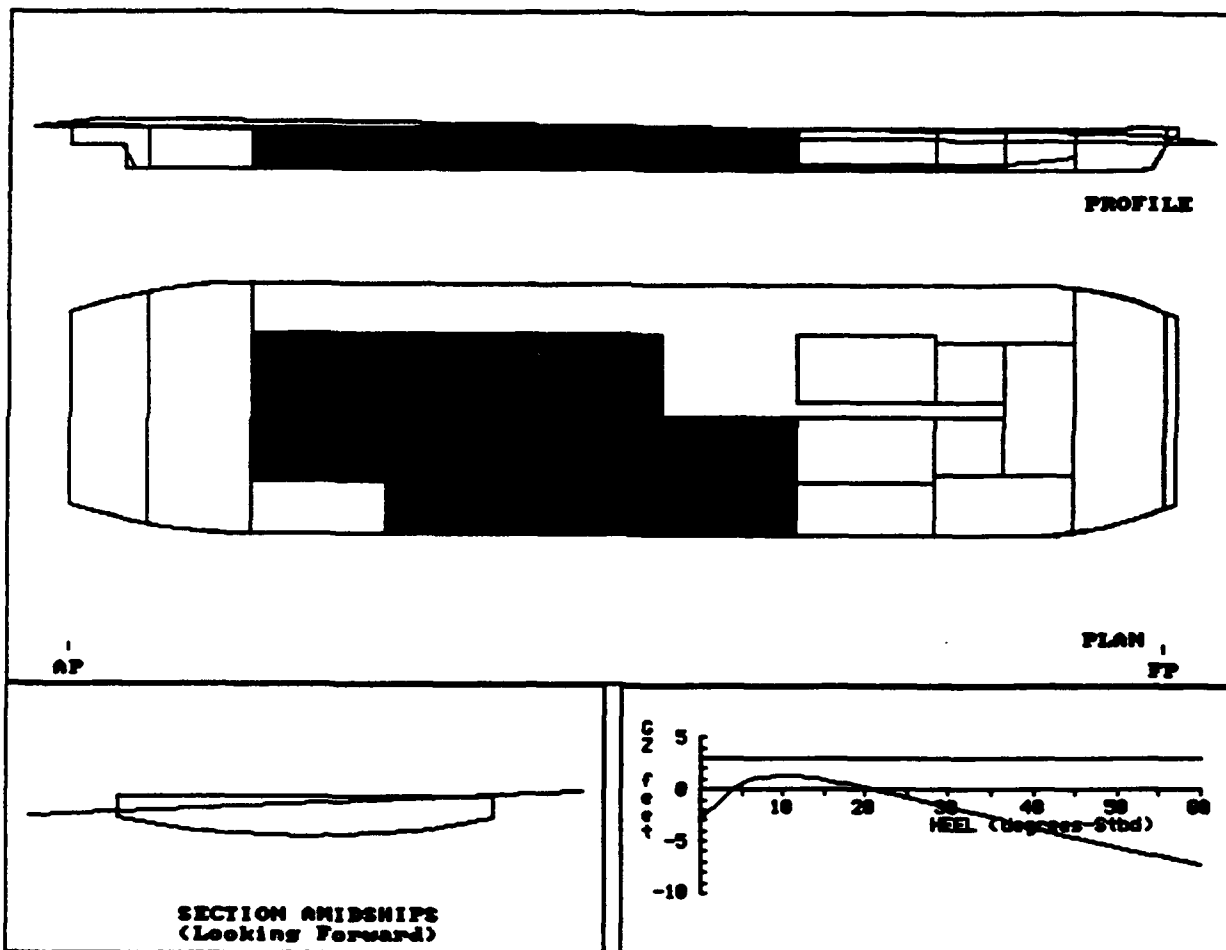

DPTA018A:
 192' FERRY

COMPARTMENT FLOODING SUMMARY

At 4.00S Heel	PERM.	FLOODED WTR LTons	% FULL (Damaged)	% FULL (Intact)	SP.VOL. ft ³ /LT	OUTFLOW LTons
BALLAST3	0.95	61.1	FREE	0.0	----	----
VOID2	0.95	95.1	FREE	0.0	----	----
BALLAST4	0.95	128.8	FREE	0.0	----	----
ENG ROOM	0.85	523.6	FREE	0.0	----	----
Totals		808.6				

INTACT DATA

Draft at AP = 6.750 ft	KMt = 91.785 ft	LCG = 95.090A ft-FP
Draft at FP = 6.010 ft	VCG = 17.340 ft	LCB = 95.142A ft-FP
Displacement = 1382.9 LTons	GMT = 74.445 ft	TCG = 0.000 ft-CL

DRAFT/GZ DATA

HEEL degrees	RIGHTING ARM ft	DRAFT AFT ft	DRAFT FWD ft	FLOODED WATER LTons
0.00	-3.198	9.863	7.016	723.0
5.00S	0.522	10.798	7.020	823.6
7.00S	1.110	11.664	6.922	844.3
10.00S	1.320	13.180	6.859	863.8
20.00S	0.167	19.160	6.939	890.2
30.00S	-1.668	26.265	7.195	897.4
40.00S	-3.637	35.370	7.458	903.6
50.00S	-5.512	47.466	7.933	905.7
60.00S	-7.227	65.726	8.924	906.9

Note: Drafts are measured at A.P. and F.P along ship's centerline

GZ SUMMARY (Evaluated per IMO (SOLAS'90) Rules for Passenger Ships)

	Available	Required
Static Heel Angle	4.00S deg	7.00 deg
Angle at Maximum GZ	11.00S deg	
*** Maximum GZ	1.320 ft	3.000 ft
Range of Positive GZ	16.96 deg	15.00 deg
Righting Area (4.00-1.95)	14.616 ft-deg	2.820 ft-deg

*** indicates failure to meet criterion

DPTA019A:
 192' FERRY

Imaged Compartments:

BALLAST4 ENG ROOM BALLAST5

	DISPLACEMENT LTons	DRAFT AFT ft	DRAFT FWD ft	TRIM ft	HEEL deg.	UPRIGHT GMT ft
INTACT	1,382.9	6.750	6.010	0.740A	0.00	74.445
DAMAGED	2,078.6	10.714	6.104	4.611A	3.16S	53.794

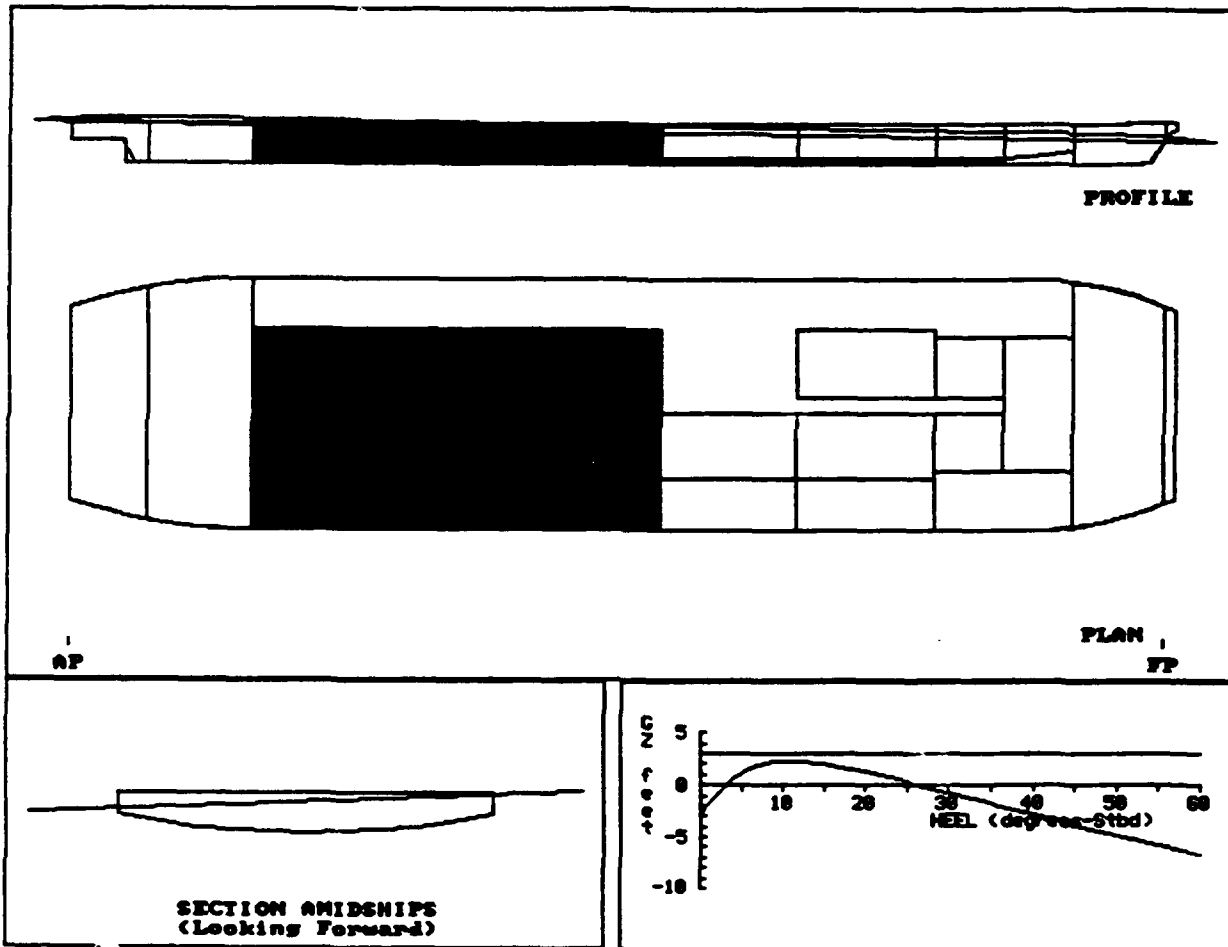

DPTA019A:
 192' FERRY

COMPARTMENT FLOODING SUMMARY

At 3.2oS Heel	PERM.	FLOODED WTR LTons	% FULL (Damaged)	% FULL (Intact)	SP.VOL. ft ³ /LT	OUTFLOW LTons
BALLAST4	0.95	122.6	FREE	0.0	----	----
ENG ROOM	0.85	510.2	FREE	0.0	----	----
BALLAST5	0.95	62.9	FREE	0.0	----	----
Totals		695.7				

INTACT DATA

Draft at AP = 6.750 ft Kmt = 91.785 ft LCG = 95.090A ft-FP
 Draft at FP = 6.010 ft VCG = 17.340 ft LCB = 95.142A ft-FP
 Displacement = 1382.9 LTons Gmt = 74.445 ft TCG = 0.000 ft-CL

DRAFT/GZ DATA

HEEL degrees	RIGHTING ARM ft	DRAFT AFT ft	DRAFT FWD ft	FLOODED WATER LTons
0.00	-2.675	10.127	6.247	638.0
5.00S	1.157	11.235	5.945	716.8
7.00S	1.918	12.147	5.644	730.4
10.00S	2.311	13.782	5.210	745.0
20.00S	1.257	20.462	3.884	771.1
30.00S	-0.671	28.504	2.491	780.0
40.00S	-2.760	38.703	0.725	784.9
50.00S	-4.785	52.330	-1.548	786.7
60.00S	-6.663	72.834	-4.748	787.5

Note: Drafts are measured at A.P. and F.P along ship's centerline

GZ SUMMARY (Evaluated per IMO (SOLAS'90) Rules for Passenger Ships)

	Available	Required
Static Heel Angle	3.16S deg	7.00 deg
Angle at Maximum GZ	12.00S deg	
*** Maximum GZ	2.327 ft	3.000 ft
Range of Positive GZ	23.48 deg	15.00 deg
Righting Area (3.16-12.00)	32.524 ft-deg	2.820 ft-deg

*** indicates failure to meet criterion

DPTA020A:
 192' FERRY

Damaged Compartments:

ENG ROOM BALLASTS VOID3

	DISPLACEMENT LTons	DRAFT AFT ft	DRAFT FWD ft	TRIM ft	HEEL deg.	UPRIGHT GMT ft
INTACT	1,382.9	6.750	6.010	0.740A	0.00	74.445
DAMAGED	2,267.1	24.591	0.765	23.826A	4.37S	19.123

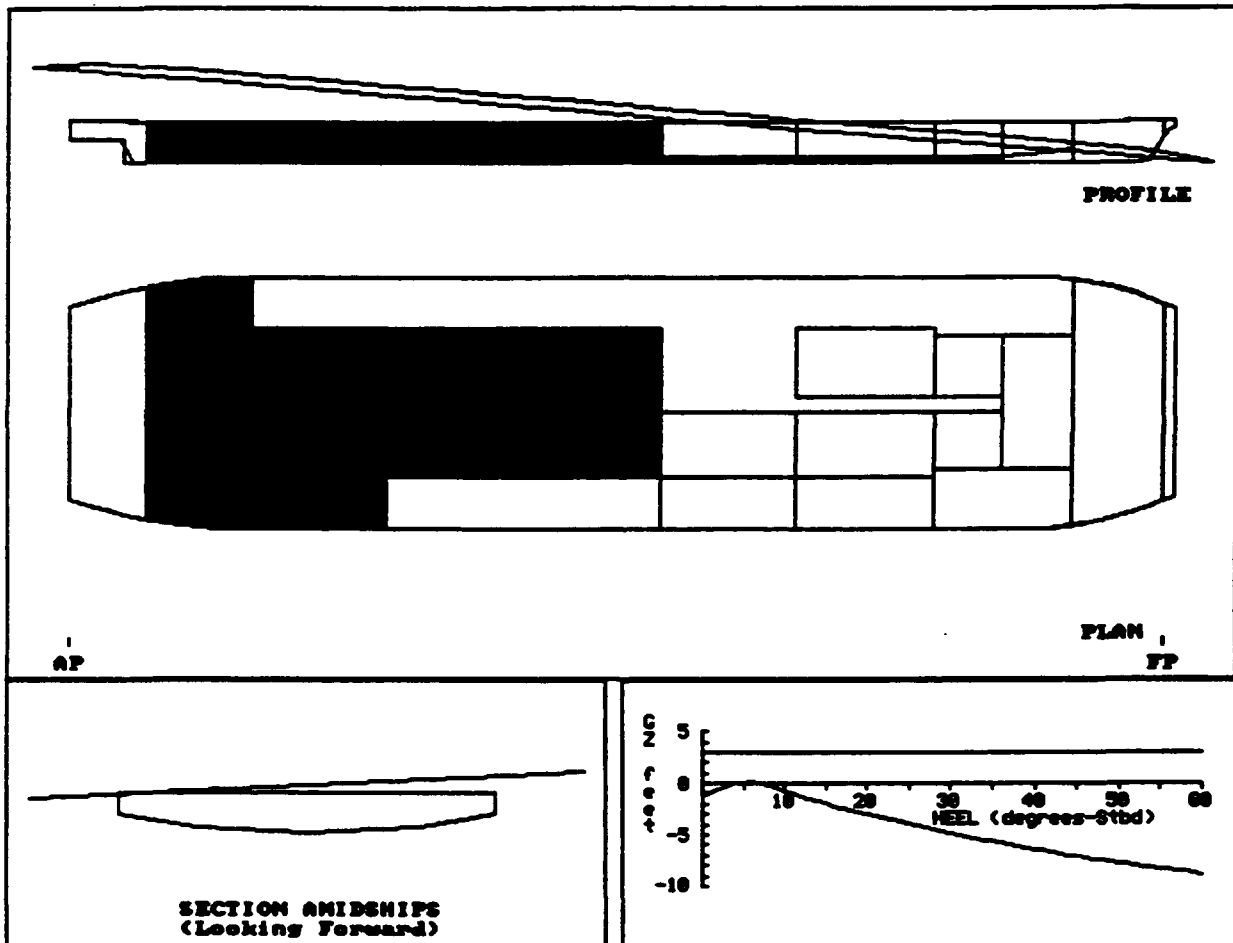

DPTA020A:
 192' FERRY

COMPARTMENT FLOODING SUMMARY

At 4.4oS Heel	PERM.	FLOODED WTR LTons	% FULL (Damaged)	% FULL (Intact)	SP.VOL. ft3/LT	OUTFLOW LTons
ENG ROOM	0.85	608.8	FREE	0.0	----	----
BALLAST5	0.95	62.9	FREE	0.0	----	----
VOID3	0.95	212.4	FREE	0.0	----	----
Totals		884.2				

INTACT DATA

Draft at AP = 6.750 ft KMT = 91.785 ft LCG = 95.090A ft-FP
 Draft at FP = 6.010 ft VCG = 17.340 ft LCB = 95.142A ft-FP
 Displacement = 1382.9 LTons GMT = 74.445 ft TCG = 0.000 ft-CL

DRAFT/GZ DATA

HEEL degrees	RIGHTING ARM ft	DRAFT AFT ft	DRAFT FWD ft	FLOOD WTR LTons	CONVERGENCE DISP(LT)	ERROR TRIM(ft)
0.00	-1.170	20.959	1.963	884.3		
5.00S	0.089	25.348	0.519	884.2		
7.00S	0.074	29.457	-0.808	884.3		
10.00S	-0.668	43.159	-5.202	884.3	0.1	>9999
20.00S	-2.907	109.553	-25.119	884.3	3.0	>9999
30.00S	-4.783	176.056	-44.926	884.3	-1.4	>9999
40.00S	-6.395	242.340	-64.952	884.3	-1.1	>9999
50.00S	-7.727	308.622	-84.980	884.3	-0.8	>9999
60.00S	-8.818	374.407	-105.505	884.3	0.4	>9999

Note: Drafts are measured at A.P. and F.P along ship's centerline

GZ SUMMARY (Evaluated per IMO (SOLAS'90) Rules for Passenger Ships)
 Available Required

Static Heel Angle	4.37S deg	7.00 deg
Angle at Maximum GZ	7.00S deg	
*** Maximum GZ	0.137 ft	3.000 ft
*** Range of Positive GZ	3.04 deg	15.00 deg
*** Righting Area (4.37-7.41)	0.262 ft-deg	2.820 ft-deg

*** indicates failure to meet criterion

DPTB001B:
 192' FERRY

aged Compartments:
 VOID1 BALLAST1

	DISPLACEMENT LTons	DRAFT AFT ft	DRAFT FWD ft	TRIM ft	HEEL deg.	UPRIGHT GMT ft
INTACT	1,453.8	6.960	6.210	0.750A	0.00	71.352
DAMAGED	1,540.3	6.539	7.147	0.608F	0.55S	62.439

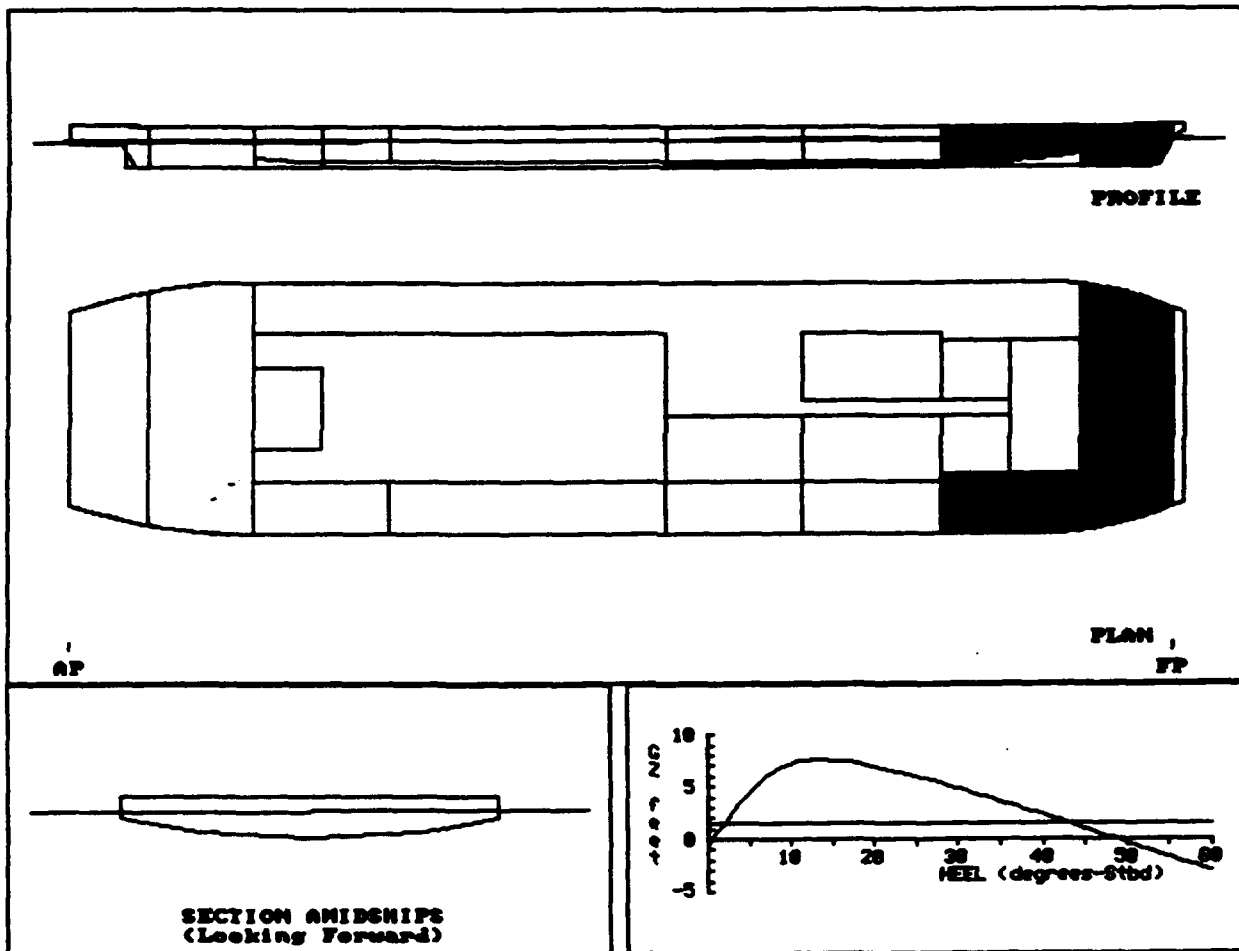

DPTB002B:
 192' FERRY

aged Compartments:

VOID1 BALLAST1 BOWTHRUST

	DISPLACEMENT LTons	DRAFT AFT ft	DRAFT FWD ft	TRIM ft	HEEL deg.	UPRIGHT GMT ft
INTACT	1,453.8	6.960	6.210	0.750A	0.00	71.352
DAMAGED	1,645.5	6.067	8.212	2.145F	0.70S	60.742

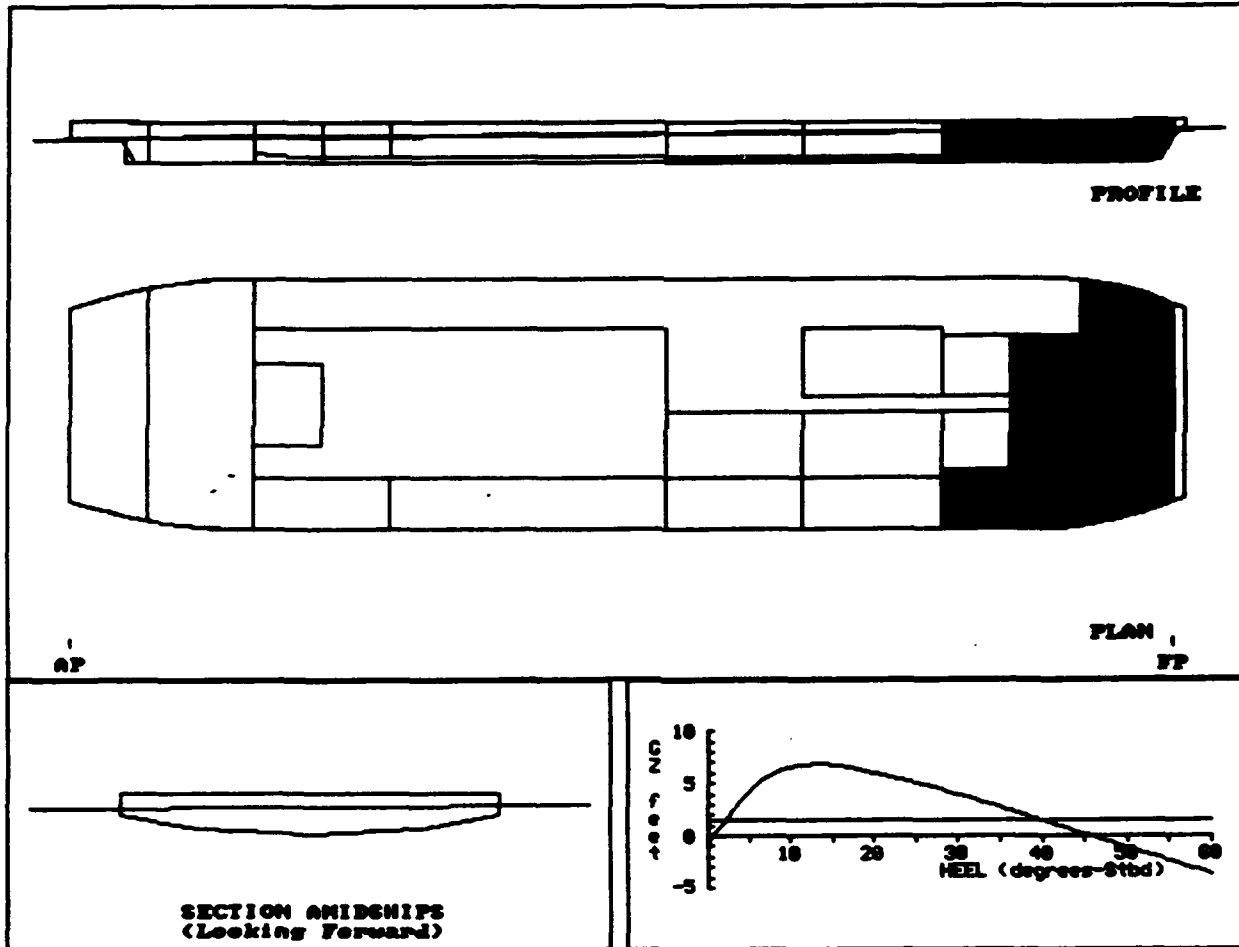

DPTB002B:
 192' FERRY

COMPARTMENT FLOODING SUMMARY

At 0.7oS Heel	PERM.	FLOODED WTR LTons	% FULL (Damaged)	% FULL (Intact)	SP.VOL. ft3/LT	OUTFLO' LTons
VOID1	0.95	70.4	FREE	0.0	----	----
BALLAST1	0.95	48.2	FREE	0.0	----	----
BOWTHRUST	0.95	73.1	FREE	0.0	----	----
Totals		191.7				

INTACT DATA

Draft at AP = 6.960 ft Kmt = 87.822 ft LCG = 95.282A ft-FP
 Draft at FP = 6.210 ft VCG = 16.470 ft LCB = 95.330A ft-FP
 Displacement = 1453.8 LTons GMT = 71.352 ft TCG = 0.000 ft-CL

DRAFT/GZ DATA

HEEL degrees	RIGHTING ARM ft	DRAFT AFT ft	DRAFT FWD ft	FLOODED WATER LTons
0.00	-0.745	6.114	8.150	186.6
5.00S	4.237	5.695	8.649	228.9
7.00S	5.600	5.322	9.012	239.4
10.00S	6.574	4.719	9.765	248.9
20.00S	6.046	2.542	13.534	269.6
30.00S	3.967	-0.054	18.489	280.4
40.00S	1.502	-3.362	24.876	287.2
50.00S	-1.090	-8.002	33.702	291.9
60.00S	-3.659	-15.049	47.132	294.7

Note: Drafts are measured at A.P. and F.P along ship's centerline

GZ SUMMARY (Evaluated per IMO (SOLAS'90) Rules for Passenger Ships)
 Available Required

Static Heel Angle	0.70S deg	7.00 deg
Angle at Maximum GZ	14.00S deg	
Maximum GZ	6.829 ft	1.500 ft
Range of Positive GZ	45.11 deg	15.00 deg
Righting Area (0.70-%.00)	115.643 ft-deg	2.820 ft-deg

DPTB003B:
 192' FERRY

Imaged Compartments:
 BALLAST1

	DISPLACEMENT LTons	DRAFT AFT ft	DRAFT FWD ft	TRIM ft	HEEL deg.	UPRIGHT GMT ft
INTACT	1,453.8	6.960	6.210	0.750A	0.00	71.292
DAMAGED	1,487.9	6.831	6.541	0.290A	0.45S	65.902

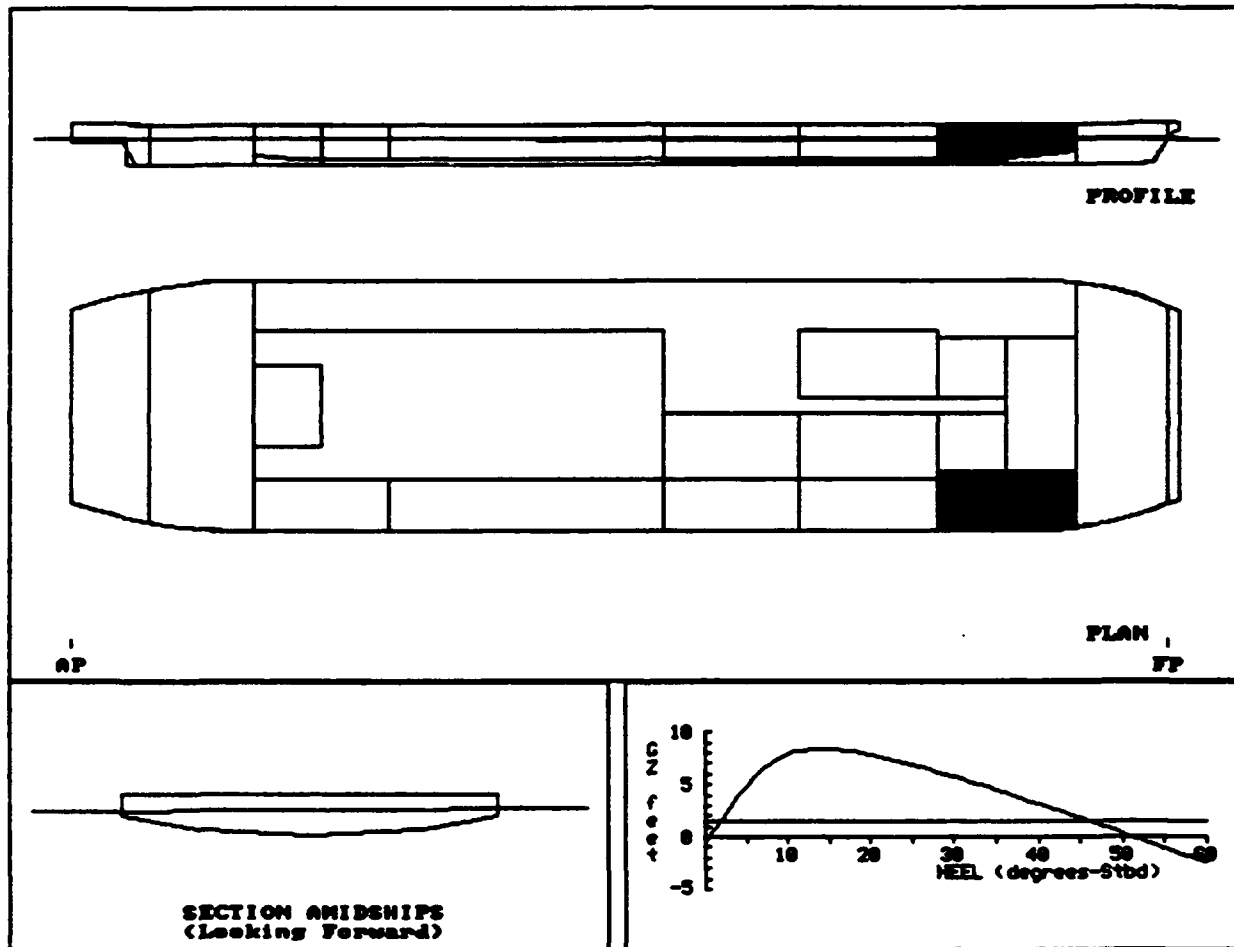

DPTB003B:
 192' FERRY

COMPARTMENT FLOODING SUMMARY

At 0.5oS Heel	PERM.	FLOODED WTR LTons	% FULL (Damaged)	% FULL (Intact)	SP.VOL. ft3/LT	OUTFLOW LTons
BALLAST1	0.95	34.1	FREE	0.0	----	----
Totals		34.1				

INTACT DATA

Draft at AP = 6.960 ft	KMt = 87.822 ft	LCG = 95.282A ft-FP
Draft at FP = 6.210 ft	VCG = 16.530 ft	LCB = 95.330A ft-FP
Displacement = 1453.8 LTons	GMT = 71.292 ft	TCG = 0.000 ft-CL

DRAFT/GZ DATA

HEEL degrees	RIGHTING ARM ft	DRAFT AFT ft	DRAFT FWD ft	FLOODED WATER LTons
0.00	-0.523	6.843	6.523	31.9
5.00S	4.871	6.662	6.692	55.1
7.00S	6.489	6.464	6.691	63.7
10.00S	7.860	6.195	6.706	70.5
20.00S	7.808	5.843	7.099	71.8
30.00S	5.750	5.537	7.819	71.8
40.00S	3.170	5.210	8.770	71.8
50.00S	0.383	4.779	10.111	71.8
60.00S	-2.459	4.125	12.225	71.8

Note: Drafts are measured at A.P. and F.P along ship's centerline

GZ SUMMARY (Evaluated per IMO (SOLAS'90) Rules for Passenger Ships)

	Available	Required
Static Heel Angle	0.45S deg	7.00 deg
Angle at Maximum GZ	15.00S deg	
Maximum GZ	8.423 ft	1.500 ft
Range of Positive GZ	50.90 deg	15.00 deg
Righting Area (0.45-%.00)	142.044 ft-deg	2.820 ft-deg

DPTB004B:
 192' FERRY

Loaded Compartments:
 BALLAST2 BALLAST1

	DISPLACEMENT LTons	DRAFT AFT ft	DRAFT FWD ft	TRIM ft	HEEL deg.	UPRIGHT Gmt ft
INTACT	1,453.8	6.960	6.210	0.750A	0.00	71.352
DAMAGED	1,528.5	6.748	6.854	0.106F	1.02S	61.413

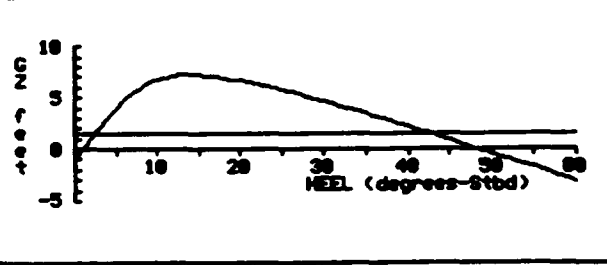
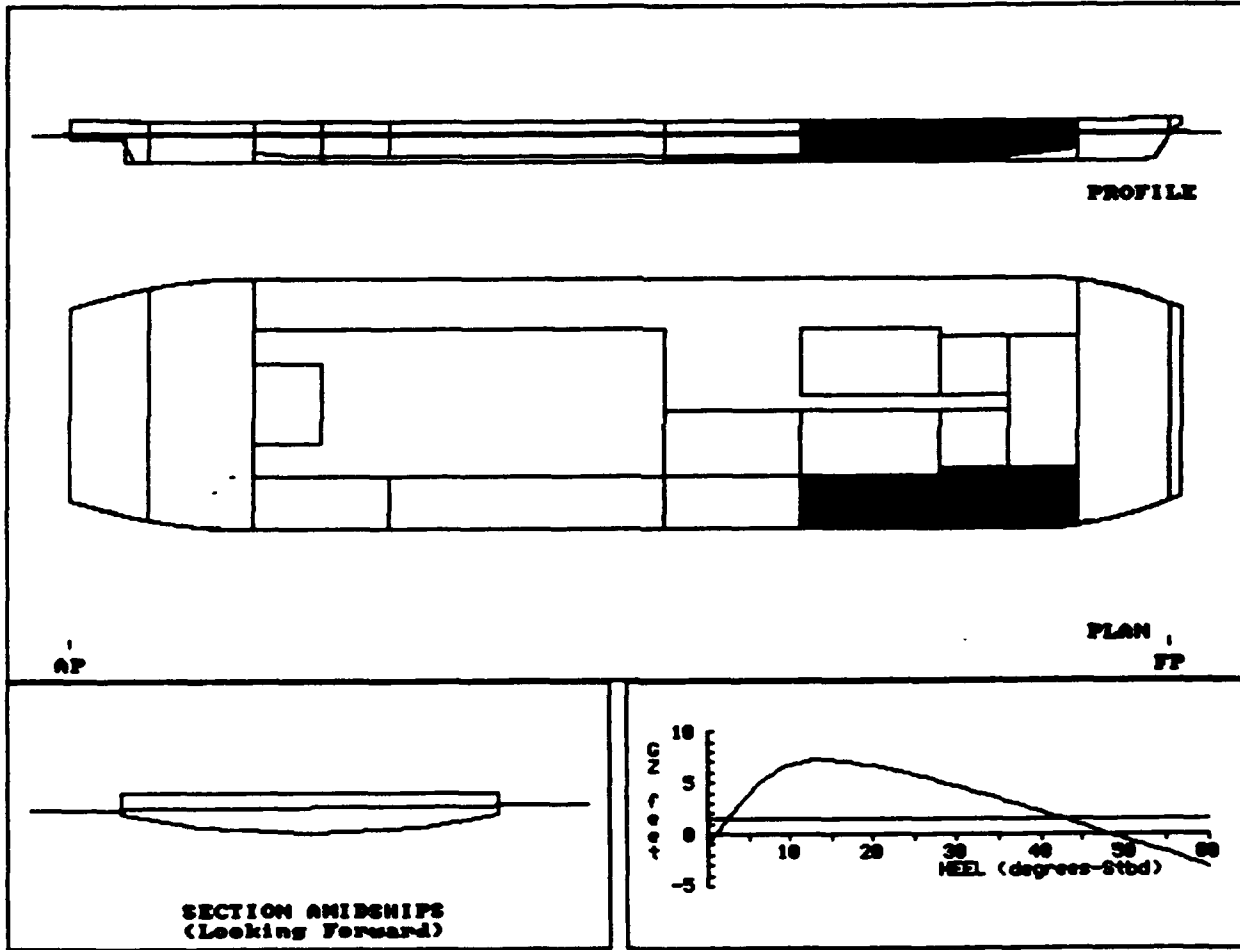

DPTB004B:
 192' FERRY

COMPARTMENT FLOODING SUMMARY

At 1.0oS Heel	PERM.	FLOODED WTR LTons	% FULL (Damaged)	% FULL (Intact)	SP.VOL. ft3/LT	OUTFLO' LTons
BALLAST2	0.95	35.5	FREE	0.0	----	----
BALLAST1	0.95	39.1	FREE	0.0	----	----
Totals		74.6				

INTACT DATA

Draft at AP = 6.960 ft	KMt = 87.822 ft	LCG = 95.282A ft-FP
Draft at FP = 6.210 ft	VCG = 16.470 ft	LCB = 95.330A ft-FP
Displacement = 1453.8 LTons	GMT = 71.352 ft	TCG = 0.000 ft-CL

DRAFT/GZ DATA

HEEL degrees	RIGHTING ARM ft	DRAFT AFT ft	DRAFT FWD ft	FLOODED WATER LTons
0.00	-1.094	6.781	6.778	65.0
5.00S	3.969	6.564	7.136	111.6
7.00S	5.489	6.336	7.240	127.8
10.00S	6.729	6.038	7.414	135.7
20.00S	6.635	5.487	8.427	135.9
30.00S	4.658	4.977	9.877	135.9
40.00S	2.201	4.361	11.757	135.9
50.00S	-0.429	3.510	14.382	135.9
60.00S	-3.083	2.324	18.353	135.9

Note: Drafts are measured at A.P. and F.P along ship's centerline

GZ SUMMARY (Evaluated per IMO (SOLAS'90) Rules for Passenger Ships)

	Available	Required
Static Heel Angle	1.02S deg	7.00 deg
Angle at Maximum GZ	15.00S deg	
Maximum GZ	7.217 ft	1.500 ft
Range of Positive GZ	47.37 deg	15.00 deg
Righting Area (1.02-3.00)	119.420 ft-deg	2.820 ft-deg

DPTB005B:
 192' FERRY

Damaged Compartments:
 BALLAST2

	DISPLACEMENT LTons	DRAFT AFT ft	DRAFT FWD ft	TRIM ft	HEEL deg.	UPRIGHT GMT ft
INTACT	1,453.8	6.960	6.210	0.750A	0.00	71.292
DAMAGED	1,484.7	6.913	6.437	0.477A	0.43S	66.192

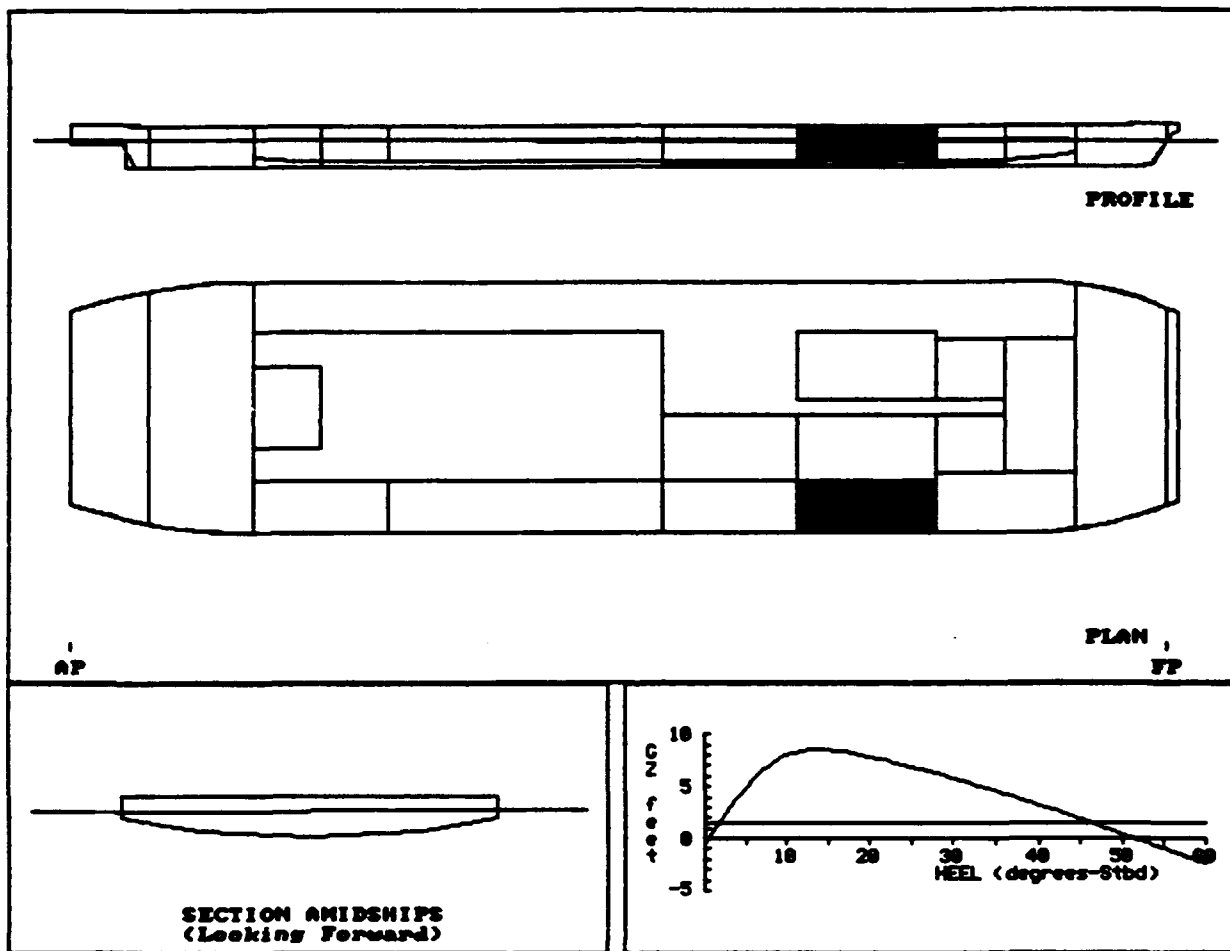

DPTB005B:
 192' FERRY

COMPARTMENT FLOODING SUMMARY

At 0.4oS Heel	PERM.	FLOODED WTR LTons	% FULL (Damaged)	% FULL (Intact)	SP.VOL. ft3/LT	OUTFLOW LTons
BALLAST2	0.95	30.9	FREE	0.0	----	----
Totals		30.9				

INTACT DATA

Draft at AP = 6.960 ft Kmt = 87.822 ft LCG = 95.282A ft-FP
 Draft at FP = 6.210 ft VCG = 16.530 ft LCB = 95.330A ft-FP
 Displacement = 1453.8 LTons GMT = 71.292 ft TCG = 0.000 ft-CL

DRAFT/GZ DATA

HEEL degrees	RIGHTING ARM ft	DRAFT AFT ft	DRAFT FWD ft	FLOODED WATER LTons
0.00	-0.501	6.918	6.428	29.1
5.00S	4.926	6.817	6.502	49.4
7.00S	6.553	6.661	6.454	56.8
10.00S	7.946	6.473	6.374	63.1
20.00S	7.908	6.376	6.468	64.1
30.00S	5.849	6.446	6.771	64.1
40.00S	3.263	6.502	7.278	64.1
50.00S	0.465	6.627	7.985	64.1
60.00S	-2.393	6.831	9.112	64.1

Note: Drafts are measured at A.P. and F.P along ship's centerline

GZ SUMMARY (Evaluated per IMO (SOLAS'90) Rules for Passenger Ships)
 Available Required

Static Heel Angle	0.43S deg	7.00 deg
Angle at Maximum GZ	15.00S deg	
Maximum GZ	8.524 ft	1.500 ft
Range of Positive GZ	51.20 deg	15.00 deg
Righting Area (0.43-1.00)	143.759 ft-deg	2.820 ft-deg

DPTB006B:
 192' FERRY

aged Compartments:
 BALLAST2 BALLAST3

	DISPLACEMENT LTons	DRAFT AFT ft	DRAFT FWD ft	TRIM ft	HEEL deg.	UPRIGHT Gmt ft
INTACT	1,453.8	6.960	6.210	0.750A	0.00	71.352
DAMAGED	1,522.8	6.938	6.631	0.308A	0.97S	61.891

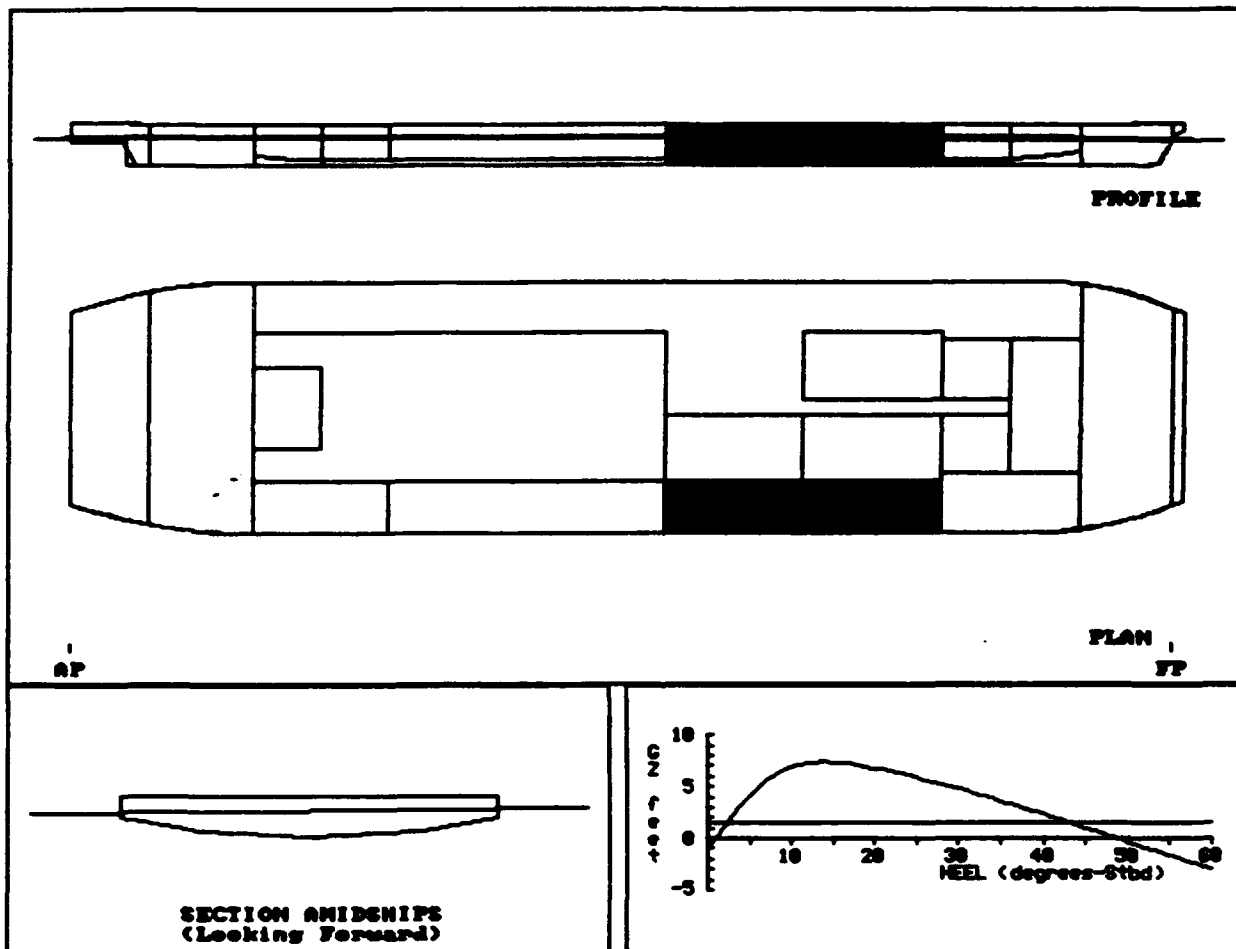

DPTB006B:
 192' FERRY

COMPARTMENT FLOODING SUMMARY

At 1.0oS Heel	PERM.	FLOODED WTR LTons	% FULL (Damaged)	% FULL (Intact)	SP.VOL. ft ³ /LT	OUTFLO LTons
BALLAST2	0.95	34.3	FREE	0.0	----	----
BALLAST3	0.95	34.7	FREE	0.0	----	----
Totals		69.0				

INTACT DATA

Draft at AP = 6.960 ft	KMt = 87.822 ft	LCG = 95.282A ft-FP
Draft at FP = 6.210 ft	VCG = 16.470 ft	LCB = 95.330A ft-FP
Displacement = 1453.8 LTons	GMT = 71.352 ft	TCG = 0.000 ft-CL

DRAFT/GZ DATA

HEEL degrees	RIGHTING ARM ft	DRAFT AFT ft	DRAFT FWD ft	FLOODED WATER LTons
0.00	-1.047	6.945	6.588	60.7
5.00S	4.083	6.865	6.785	102.7
7.00S	5.632	6.721	6.797	117.9
10.00S	6.876	6.564	6.827	127.6
20.00S	6.795	6.514	7.306	128.1
30.00S	4.814	6.623	8.085	128.1
40.00S	2.345	6.783	9.124	128.1
50.00S	-0.302	7.007	10.582	128.1
60.00S	-2.981	7.331	12.886	128.1

Note: Drafts are measured at A.P. and F.P along ship's centerline

GZ SUMMARY (Evaluated per IMO (SOLAS'90) Rules for Passenger Ships)

	Available	Required
Static Heel Angle	0.97S deg	7.00 deg
Angle at Maximum GZ	15.00S deg	
Maximum GZ	7.366 ft	1.500 ft
Range of Positive GZ	47.91 deg	15.00 deg
Righting Area (0.97-4.00)	122.300 ft-deg	2.820 ft-deg

DPTB007B:
 192' FERRY

Damaged Compartments:
 BALLASTS

	DISPLACEMENT LTons	DRAFT AFT ft	DRAFT FWD ft	TRIM ft	HEEL deg.	UPRIGHT GMT ft
INTACT	1,453.8	6.960	6.210	0.750A	0.00	71.292
DAMAGED	1,485.1	6.986	6.363	0.623A	0.44S	66.151

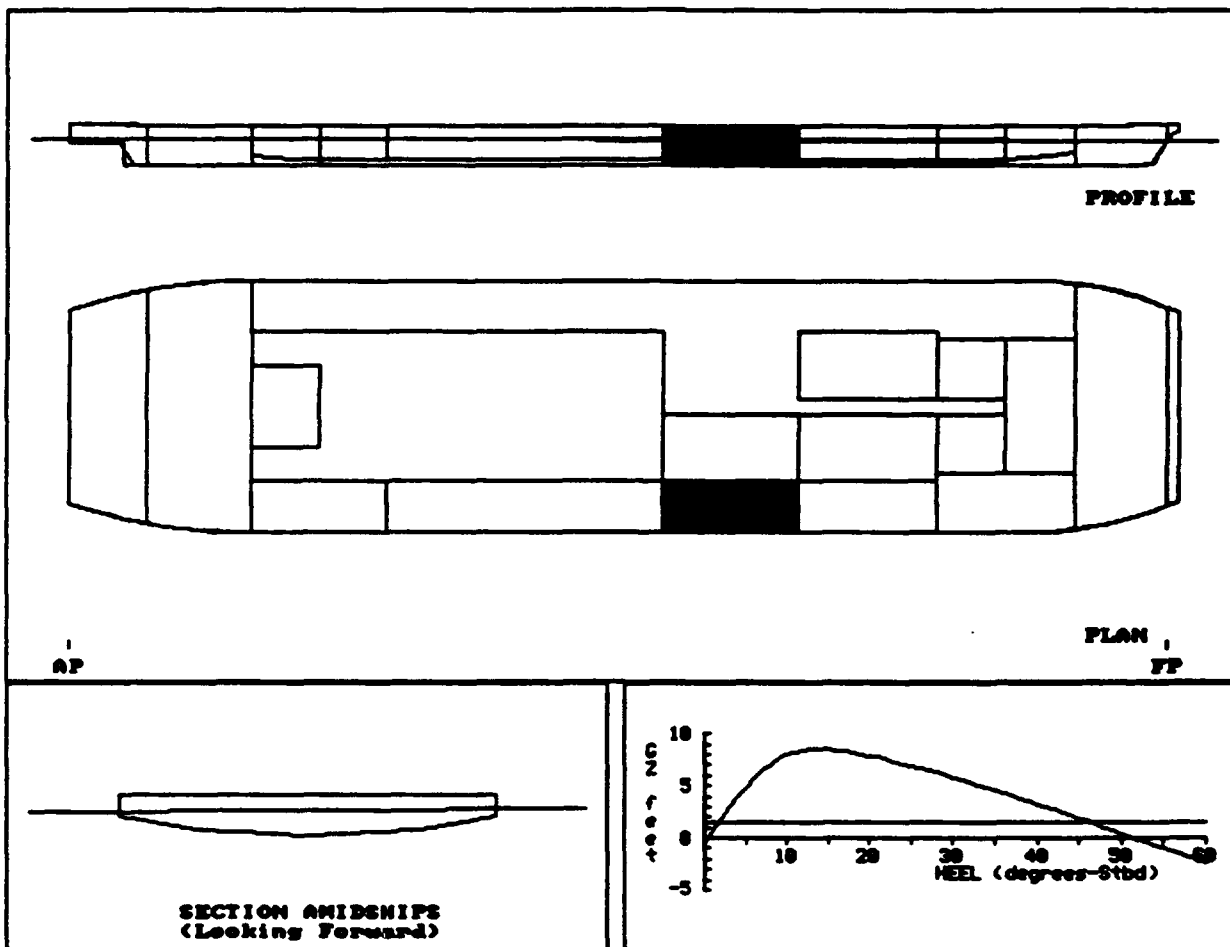

DPTB007B:
 192' FERRY

COMPARTMENT FLOODING SUMMARY

At 0.4oS Heel	PERM.	FLOODED WTR LTons	% FULL (Damaged)	% FULL (Intact)	SP.VOL. ft ³ /LT	OUTFLOW LTons
BALLAST3	0.95	31.3	FREE	0.0	----	----
Totals		31.3				

INTACT DATA

Draft at AP = 6.960 ft	Kmt = 87.822 ft	LCG = 95.282A ft-FP
Draft at FP = 6.210 ft	VCG = 16.530 ft	LCB = 95.330A ft-FP
Displacement = 1453.8 LTons	Gmt = 71.292 ft	TCG = 0.000 ft-CL

DRAFT/GZ DATA

HEEL degrees	RIGHTING ARM ft	DRAFT AFT ft	DRAFT FWD ft	FLOODED WATER LTons
0.00	-0.508	6.985	6.360	29.5
5.00S	4.925	6.950	6.369	49.5
7.00S	6.554	6.829	6.289	56.8
10.00S	7.947	6.711	6.143	63.0
20.00S	7.909	6.830	6.034	64.1
30.00S	5.850	7.154	6.100	64.1
40.00S	3.265	7.587	6.264	64.1
50.00S	0.468	8.184	6.539	64.1
60.00S	-2.389	9.101	7.015	64.1

Note: Drafts are measured at A.P. and F.P along ship's centerline

GZ SUMMARY (Evaluated per IMO (SOLAS'90) Rules for Passenger Ships)
 Available Required

Static Heel Angle	0.44S deg	7.00 deg
Angle at Maximum GZ	15.00S deg	
Maximum GZ	8.524 ft	1.500 ft
Range of Positive GZ	51.20 deg	15.00 deg
Righting Area (0.44-7.00)	143.749 ft-deg	2.820 ft-deg

DPTB008B:
 192' FERRY

Damaged Compartments:
 BALLAST3 BALLAST4

	DISPLACEMENT LTons	DRAFT AFT ft	DRAFT FWD ft	TRIM ft	HEEL deg.	UPRIGHT Gmt ft
INTACT	1,453.8	6.960	6.210	0.750A	0.00	71.352
DAMAGED	1,571.7	7.343	6.498	0.845A	1.65S	57.016

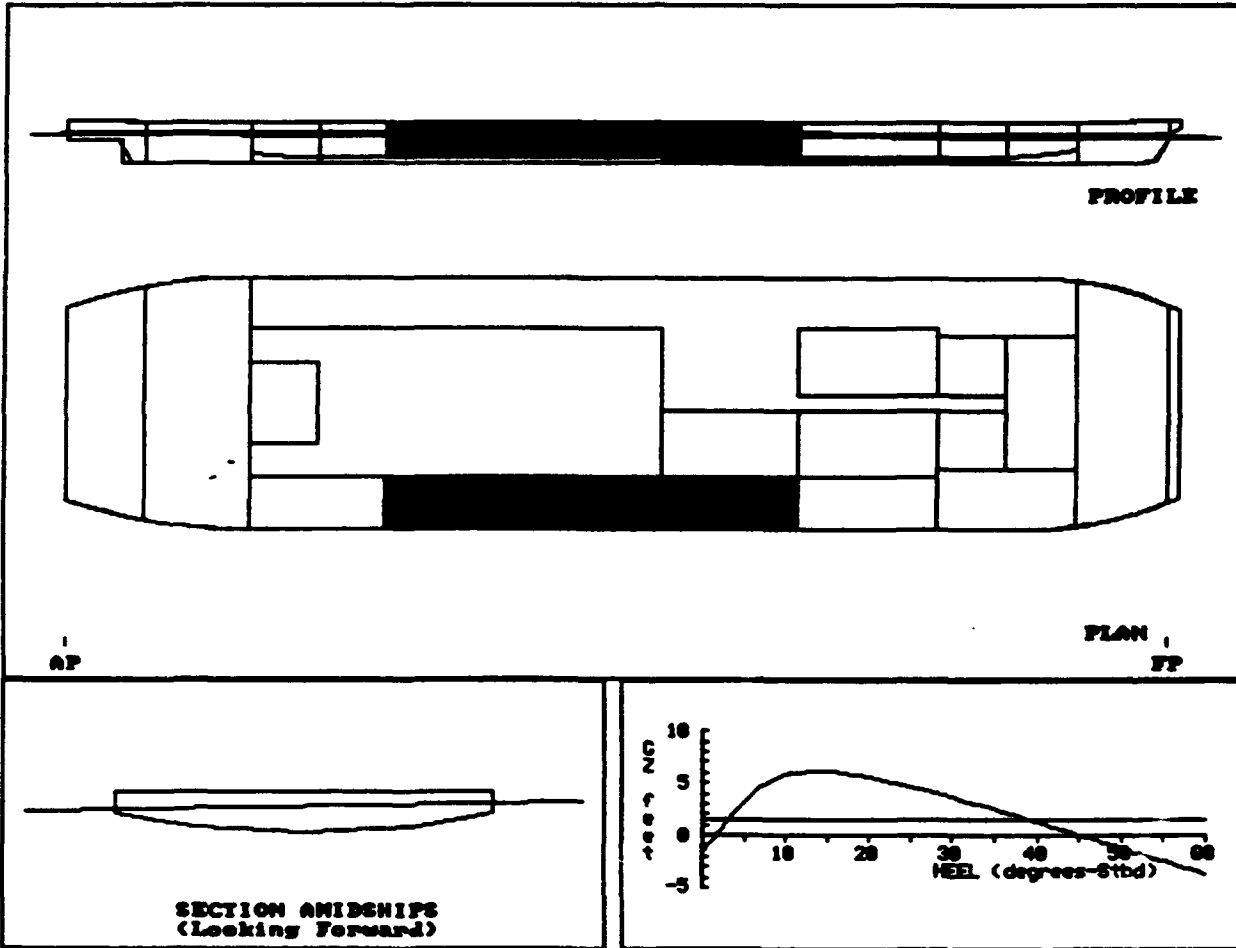

DPTB008B:
 192' FERRY

COMPARTMENT FLOODING SUMMARY

At 1.7oS Heel	PERM.	FLOODED WTR LTons	% FULL (Damaged)	% FULL (Intact)	SP.VOL. ft3/LT	OUTFLO LTons
BALLAST3	0.95	38.1	FREE	0.0	----	----
BALLAST4	0.95	79.8	FREE	0.0	----	----
Totals		117.9				

INTACT DATA

Draft at AP = 6.960 ft Kmt = 87.822 ft LCG = 95.282A ft-FP
 Draft at FP = 6.210 ft VCG = 16.470 ft LCB = 95.330A ft-FP
 Displacement = 1453.8 LTons GMT = 71.352 ft TCG = 0.000 ft-CL

DRAFT/GZ DATA

HEEL degrees	RIGHTING ARM ft	DRAFT AFT ft	DRAFT FWD ft	FLOODED WATER LTons
0.00	-1.665	7.263	6.462	96.3
5.00S	3.143	7.475	6.529	160.8
7.00S	4.583	7.506	6.461	182.8
10.00S	5.711	7.642	6.343	193.4
20.00S	5.576	8.547	6.357	193.5
30.00S	3.674	9.868	6.510	193.5
40.00S	1.330	11.530	6.784	193.5
50.00S	-1.158	13.794	7.198	193.5
60.00S	-3.661	17.252	7.893	193.5

Note: Drafts are measured at A.P. and F.P along ship's centerline

GZ SUMMARY (Evaluated per IMO (SOLAS'90) Rules for Passenger Ships)

	Available	Required
Static Heel Angle	1.65S deg	7.00 deg
Angle at Maximum GZ	15.00S deg	
Maximum GZ	6.134 ft	1.500 ft
Range of Positive GZ	43.72 deg	15.00 deg
Righting Area (1.65-7.00)	99.259 ft-deg	2.820 ft-deg

DPTB009B:
 192' FERRY

Used Compartments:
 BALLAST

	DISPLACEMENT LTons	DRAFT AFT ft	DRAFT FWD ft	TRIM ft	HEEL deg.	UPRIGHT GMT ft
INTACT	1,453.8	6.960	6.210	0.750A	0.00	71.292
DAMAGED	1,526.4	7.278	6.299	0.979A	1.02S	61.447

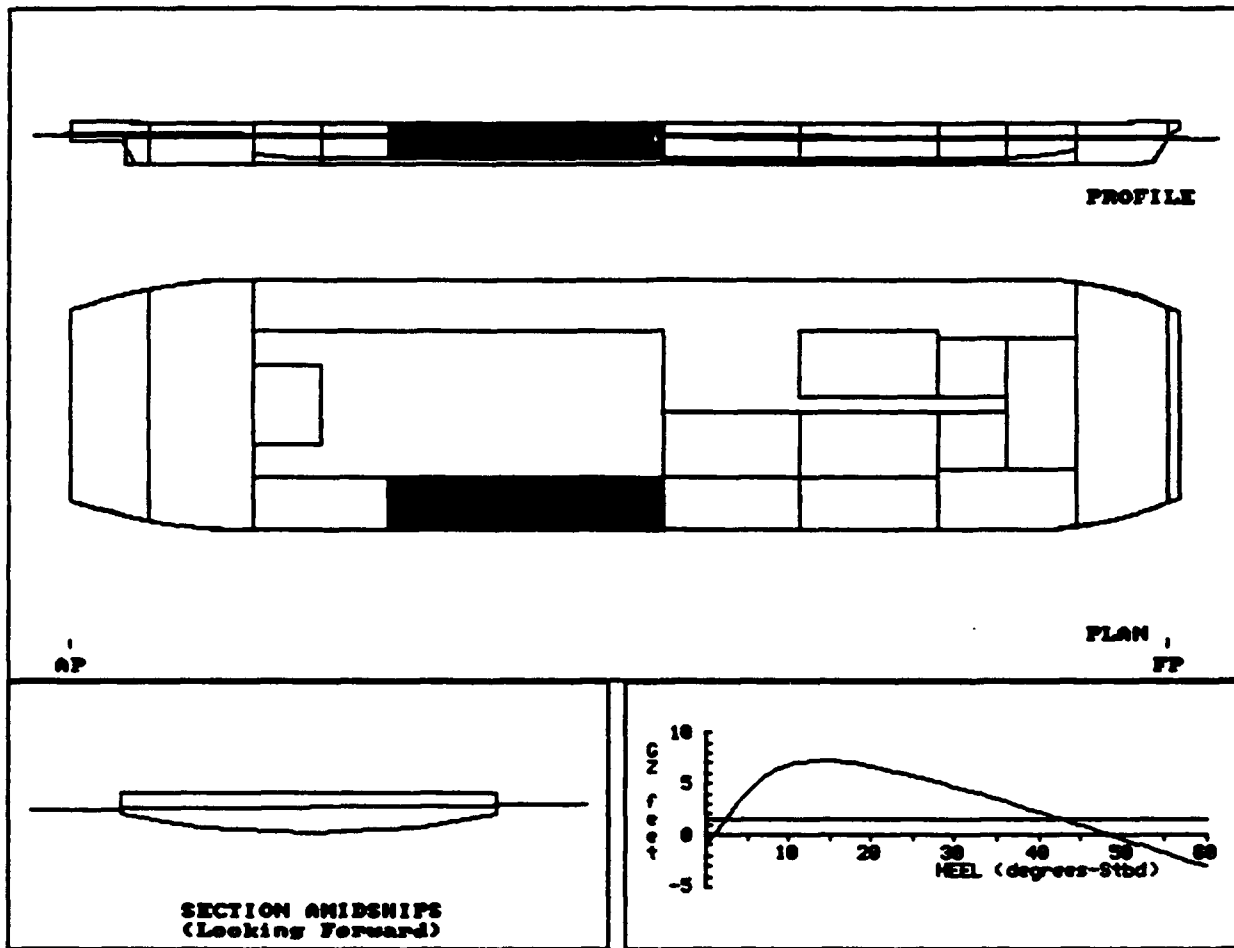

DPTB009B:
 192' FERRY

COMPARTMENT FLOODING SUMMARY

At 1.0oS Heel	PERM.	FLOODED WTR LTons	% FULL (Damaged)	% FULL (Intact)	SP.VOL. ft3/LT	OUTFLOW LTons
BALLAST4	0.95	72.6	FREE	0.0	----	----
Totals		72.6				

INTACT DATA

Draft at AP = 6.960 ft Kmt = 87.822 ft LCG = 95.282A ft-FP
 Draft at FP = 6.210 ft VCG = 16.530 ft LCB = 95.330A ft-FP
 Displacement = 1453.8 LTons GMT = 71.292 ft TCG = 0.000 ft-CL

DRAFT/GZ DATA

HEEL degrees	RIGHTING ARM ft	DRAFT AFT ft	DRAFT FWD ft	FLOODED WATER LTons
0.00	-1.103	7.234	6.303	63.8
5.00S	4.018	7.419	6.244	105.9
7.00S	5.549	7.430	6.120	120.7
10.00S	6.799	7.545	5.894	129.2
20.00S	6.713	8.409	5.514	129.5
30.00S	4.730	9.631	5.263	129.5
40.00S	2.263	11.198	5.014	129.5
50.00S	-0.379	13.334	4.727	129.5
60.00S	-3.051	16.617	4.336	129.5

Note: Drafts are measured at A.P. and F.P along ship's centerline

GZ SUMMARY (Evaluated per IMO (SOLAS'90) Rules for Passenger Ships)
 Available Required

Static Heel Angle	1.02S deg	7.00 deg
Angle at Maximum GZ	15.00S deg	
Maximum GZ	7.296 ft	1.500 ft
Range of Positive GZ	47.56 deg	15.00 deg
Righting Area (1.02-7.00)	120.753 ft-deg	2.820 ft-deg

DPTB010B:
 192' FERRY

aged Compartments:
 BALLAST4 BALLAST5

	DISPLACEMENT LTons	DRAFT AFT ft	DRAFT FWD ft	TRIM ft	HEEL deg.	UPRIGHT GMT ft
INTACT	1,453.8	6.960	6.210	0.750A	0.00	71.352
DAMAGED	1,577.1	7.647	6.211	1.436A	1.74S	56.408

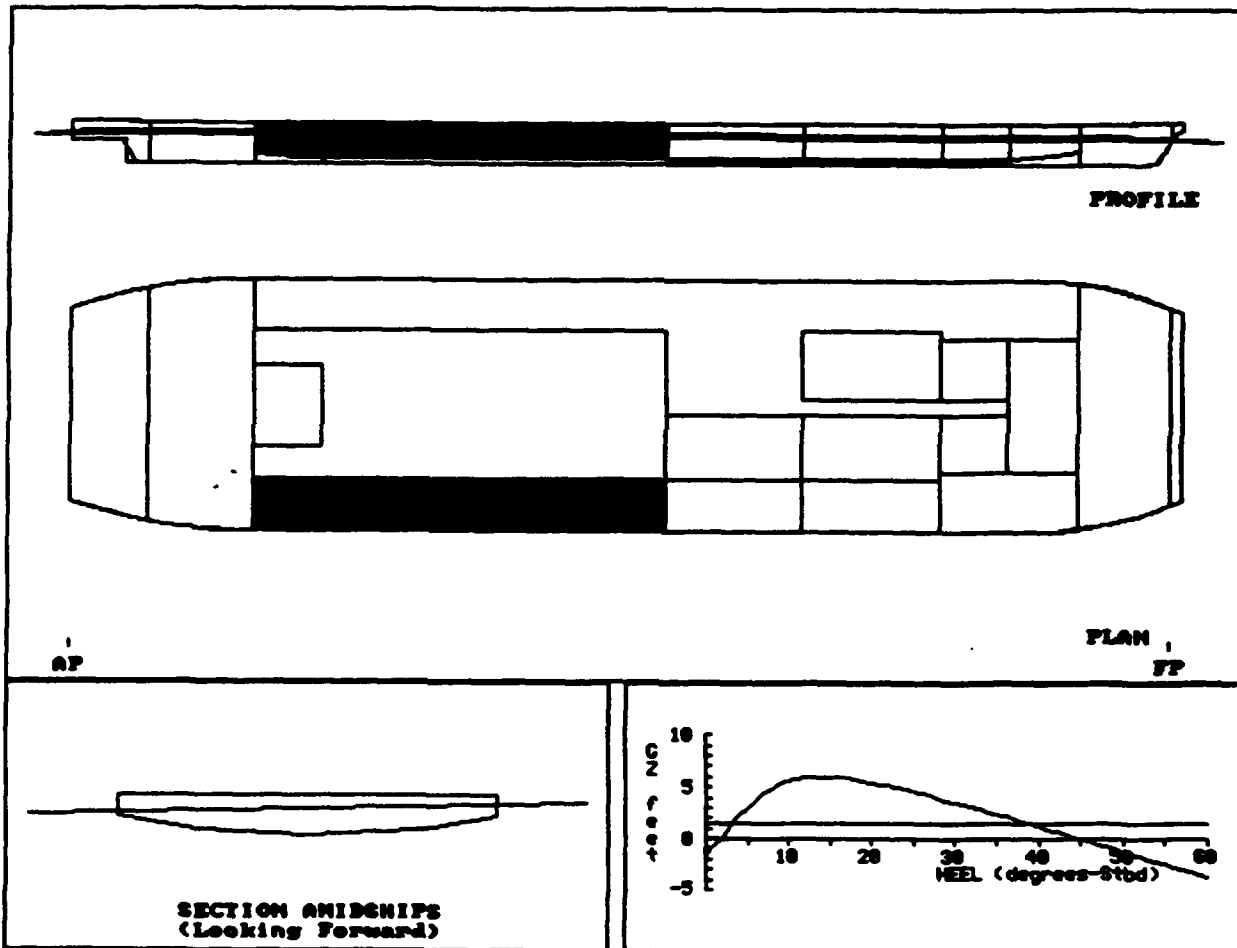

DPTB010B:
 192' FERRY

COMPARTMENT FLOODING SUMMARY

At 1.7oS Heel	PERM.	FLOODED WTR LTons	‡ FULL (Damaged)	‡ FULL (Intact)	SP.VOL. ft3/LT	OUTFLO' LTons
BALLAST4	0.95	81.5	FREE	0.0	----	----
BALLAST5	0.95	41.8	FREE	0.0	----	----
Totals		123.3				

INTACT DATA

Draft at AP = 6.960 ft	Kmt = 87.822 ft	LCG = 95.282A ft-FP
Draft at FP = 6.210 ft	VCG = 16.470 ft	LCB = 95.330A ft-FP
Displacement = 1453.8 LTons	GMT = 71.352 ft	TCG = 0.000 ft-CL

DRAFT/GZ DATA

HEEL degrees	RIGHTING ARM ft	DRAFT AFT ft	DRAFT FWD ft	FLOODED WATER LTons
0.00	-1.734	7.499	6.241	100.1
5.00S	3.017	7.913	6.105	166.4
7.00S	4.428	8.062	5.940	186.2
10.00S	5.602	8.365	5.649	192.4
20.00S	5.468	9.948	5.011	192.4
30.00S	3.572	12.048	4.456	192.4
40.00S	1.240	14.706	3.825	192.4
50.00S	-1.233	18.349	2.996	192.4
60.00S	-3.715	23.850	1.864	192.4

Note: Drafts are measured at A.P. and F.P along ship's centerline

GZ SUMMARY (Evaluated per IMO (SOLAS'90) Rules for Passenger Ships)

	Available	Required
Static Heel Angle	1.74S deg	7.00 deg
Angle at Maximum GZ	15.00S deg	
Maximum GZ	6.058 ft	1.500 ft
Range of Positive GZ	43.30 deg	15.00 deg
Righting Area (1.74-‡.00)	97.121 ft-deg	2.820 ft-deg

DPTB011B:
 192' FERRY

Loaded Compartments:
 BALLASTS

	DISPLACEMENT LTons	DRAFT AFT ft	DRAFT FWD ft	TRIM ft	HEEL deg.	UPRIGHT GMT ft
INTACT	1,453.8	6.960	6.210	0.750A	0.00	71.292
DAMAGED	1,487.6	7.225	6.127	1.098A	0.48S	65.788

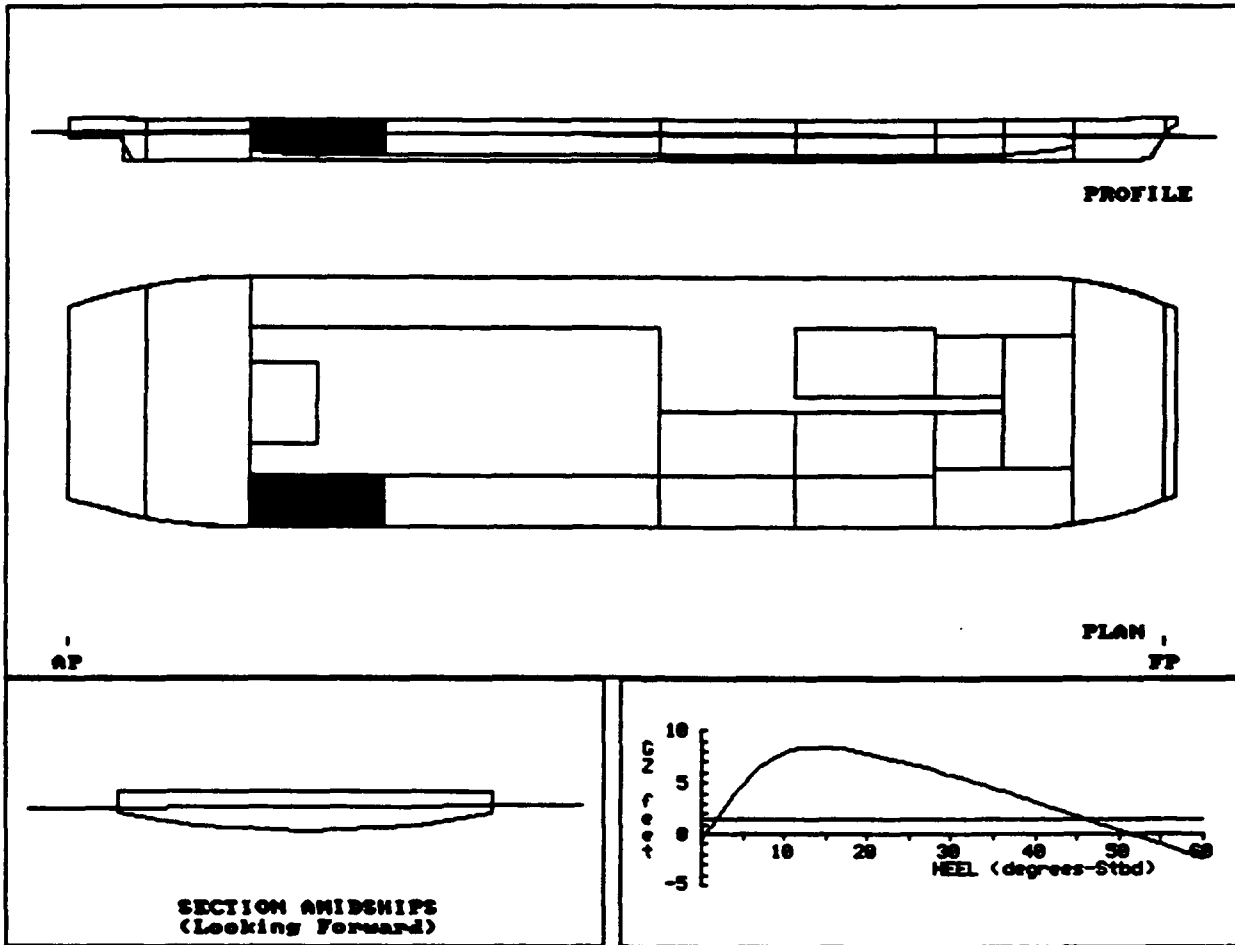

DPTB011B:
 192' FERRY

COMPARTMENT FLOODING SUMMARY

At 0.5oS Heel	PERM.	FLOODED WTR LTons	% FULL (Damaged)	% FULL (Intact)	SP.VOL. ft ³ /LT	OUTFLOW LTons
BALLASTS	0.95	33.8	FREE	0.0	----	----
Totals		33.8				

INTACT DATA

Draft at AP = 6.960 ft	KMt = 87.822 ft	LCG = 95.282A ft-FP
Draft at FP = 6.210 ft	VCG = 16.530 ft	LCB = 95.330A ft-FP
Displacement = 1453.8 LTons	GMT = 71.292 ft	TCG = 0.000 ft-CL

DRAFT/GZ DATA

HEEL degrees	RIGHTING ARM ft	DRAFT AFT ft	DRAFT FWD ft	FLOODED WATER LTons
0.00	-0.550	7.206	6.142	31.8
5.00S	4.865	7.372	5.956	52.4
7.00S	6.480	7.361	5.778	59.4
10.00S	7.883	7.430	5.453	62.9
20.00S	7.863	8.167	4.749	62.9
30.00S	5.808	9.307	4.066	62.9
40.00S	3.230	10.736	3.322	62.9
50.00S	0.443	12.685	2.378	62.9
60.00S	-2.401	15.681	0.987	62.9

Note: Drafts are measured at A.P. and F.P along ship's centerline

GZ SUMMARY (Evaluated per IMO (SOLAS'90) Rules for Passenger Ships)
 Available Required

Static Heel Angle	0.48S deg	7.00 deg
Angle at Maximum GZ	15.00S deg	
Maximum GZ	8.474 ft	1.500 ft
Range of Positive GZ	51.09 deg	15.00 deg
Righting Area (0.48-7.00)	142.566 ft-deg	2.820 ft-deg

DPTB012B:
 192' FERRY

Waged Compartments:
 BALLASTS VOID3

	DISPLACEMENT LTons	DRAFT AFT ft	DRAFT FWD ft	TRIM ft	HEEL deg.	UPRIGHT Gmt ft
INTACT	1,453.8	6.960	6.210	0.750A	0.00	71.352
DAMAGED	1,634.7	8.653	5.492	3.161A	0.69S	57.409

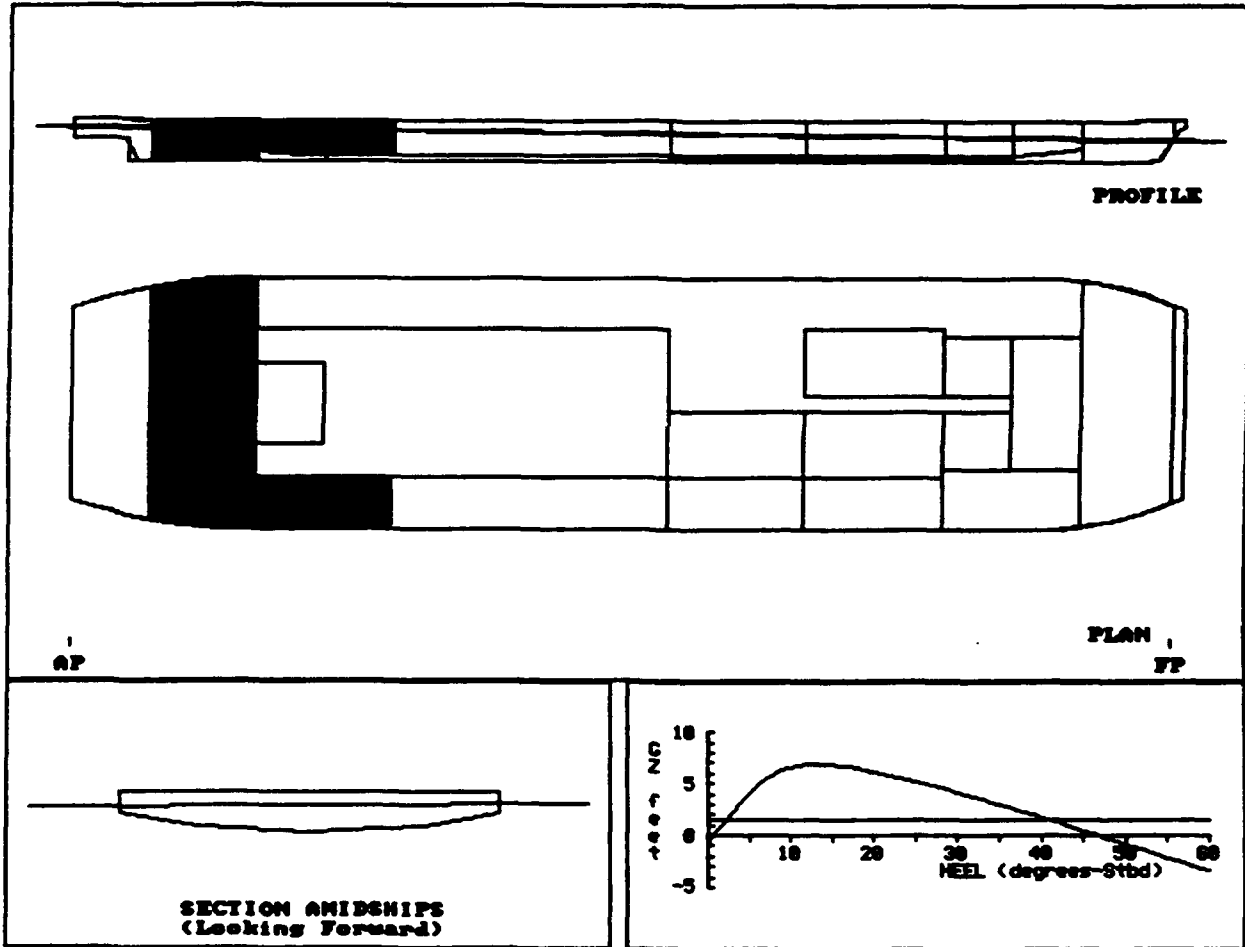

DPTB012B:
 192' FERRY

COMPARTMENT FLOODING SUMMARY

At 0.7oS Heel	PERM.	FLOODED WTR LTons	% FULL (Damaged)	% FULL (Intact)	SP.VOL. ft ³ /LT	OUTFLOW LTons
BALLAST5	0.95	42.9	FREE	0.0	----	----
VOID3	0.95	138.0	FREE	0.0	----	----
Totals		180.9				

INTACT DATA

Draft at AP = 6.960 ft	KMT = 87.822 ft	LCG = 95.282A ft-FP
Draft at FP = 6.210 ft	VCG = 16.470 ft	LCB = 95.330A ft-FP
Displacement = 1453.8 LTons	GMT = 71.352 ft	TCG = 0.000 ft-CL

DRAFT/GZ DATA

HEEL degrees	RIGHTING ARM ft	DRAFT AFT ft	DRAFT FWD ft	FLOODED WATER LTons
0.00	-0.699	8.614	5.520	177.2
5.00S	4.089	8.940	5.248	204.7
7.00S	5.456	9.213	4.951	206.7
10.00S	6.521	9.811	4.435	207.5
20.00S	6.180	12.834	2.681	213.2
30.00S	4.175	16.799	0.711	217.2
40.00S	1.742	21.906	-1.772	220.1
50.00S	-0.839	28.958	-5.223	222.3
60.00S	-3.424	39.772	-10.508	224.0

Note: Drafts are measured at A.P. and F.P along ship's centerline

GZ SUMMARY (Evaluated per IMO (SOLAS'90) Rules for Passenger Ships)

	Available	Required
Static Heel Angle	0.69S deg	7.00 deg
Angle at Maximum GZ	15.00S deg	
Maximum GZ	6.864 ft	1.500 ft
Range of Positive GZ	46.08 deg	15.00 deg
Righting Area (0.69-%.00)	115.566 ft-deg	2.820 ft-deg

DPTB013B:
 192' FERRY

Waged Compartments:
 VOID3 VOID4

	DISPLACEMENT LTons	DRAFT AFT ft	DRAFT FWD ft	TRIM ft	HEEL deg.	UPRIGHT GMT ft
INTACT	1,453.8	6.960	6.210	0.750A	0.00	71.352
DAMAGED	1,670.7	9.198	5.133	4.065A	0.00	57.581

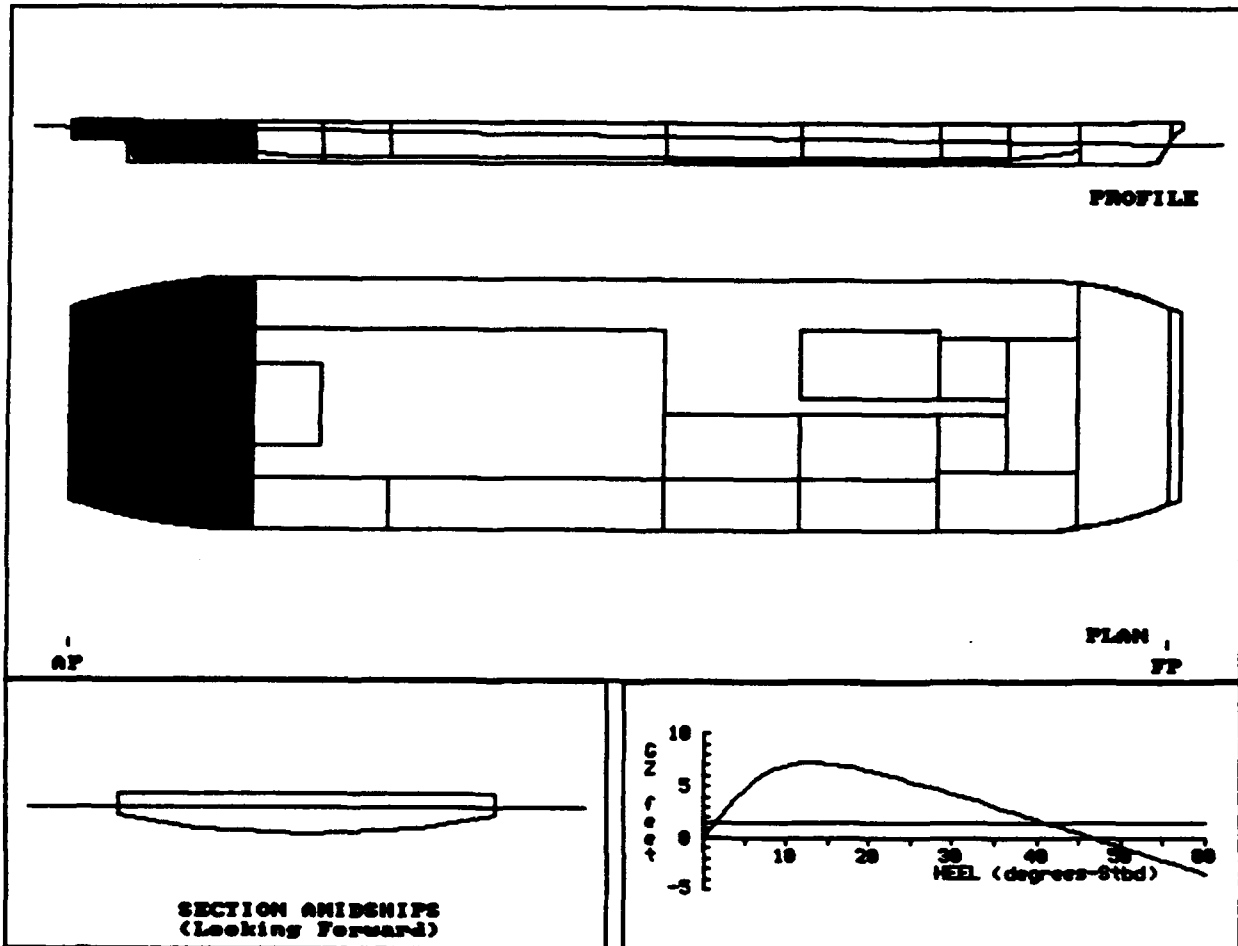

DPTB013B:
 192' FERRY

COMPARTMENT FLOODING SUMMARY

At 0.0o Heel	PERM.	FLOODED WTR LTons	% FULL (Damaged)	% FULL (Intact)	SP.VOL. ft ³ /LT	OUTFLO' LTons
VOID3	0.95	152.1	FREE	0.0	----	----
VOID4	0.95	64.8	FREE	0.0	----	----
Totals		216.9				

INTACT DATA

Draft at AP = 6.960 ft	KMt = 87.822 ft	LCG = 95.282A ft-FP
Draft at FP = 6.210 ft	VCG = 16.470 ft	LCB = 95.330A ft-FP
Displacement = 1453.8 LTons	GMT = 71.352 ft	TCG = 0.000 ft-CL

DRAFT/GZ DATA

HEEL degrees	RIGHTING ARM ft	DRAFT AFT ft	DRAFT FWD ft	FLOODED WATER LTons
0.00	0.000	9.198	5.133	216.9
5.00S	4.750	9.394	4.870	220.3
7.00S	6.014	9.717	4.552	220.3
10.00S	6.970	10.518	3.931	224.3
20.00S	6.467	14.611	1.532	242.1
30.00S	4.369	19.988	-1.319	253.3
40.00S	1.841	27.122	-5.125	261.9
50.00S	-0.824	37.144	-10.552	269.0
60.00S	-3.464	52.421	-18.798	274.0

Note: Drafts are measured at A.P. and F.P along ship's centerline

GZ SUMMARY (Evaluated per IMO (SOLAS'90) Rules for Passenger Ships)

	Available	Required
Static Heel Angle	0.00 deg	7.00 deg
Angle at Maximum GZ	14.00S deg	
Maximum GZ	7.242 ft	1.500 ft
Range of Positive GZ	46.91 deg	15.00 deg
Gmt (upright damaged)	57.581 ft	
Righting Area (0.00-7.00)	125.633 ft-deg	2.820 ft-deg

DPTB014B:
 192' FERRY

Waged Compartments:

	VOID1	BALLAST1	BOWTHRUST	FO #1 S			
	DISPLACEMENT	DRAFT AFT	DRAFT FWD	TRIM	HEEL	UPRIGHT	Gmt
	Ltons	ft	ft	ft	deg.	ft	
INTACT	1,453.8	6.960	6.210	0.750A	0.00	71.352	
DAMAGED	1,634.1	6.108	8.107	1.999F	0.64S	62.048	

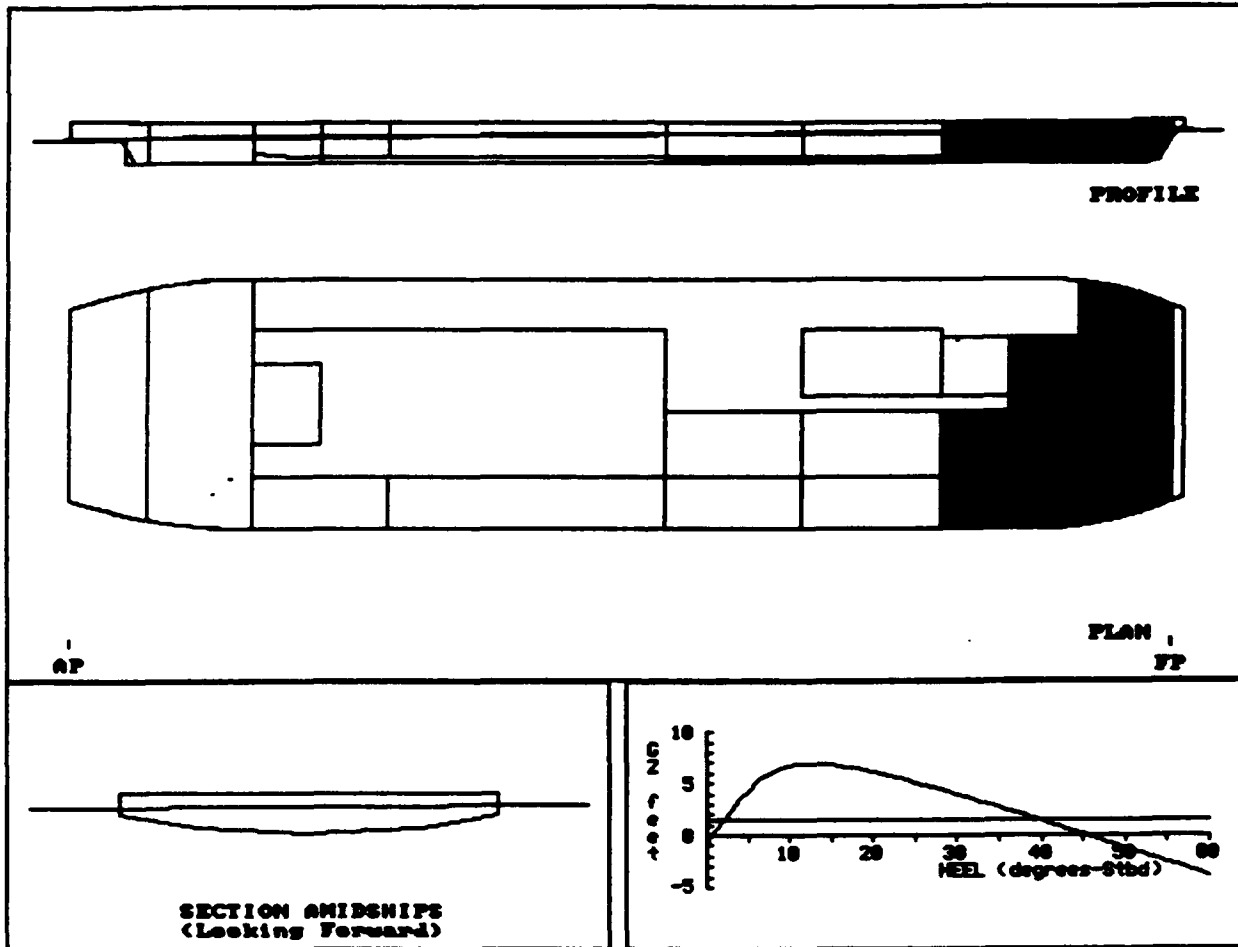

DPTB014B:
 192' FERRY

COMPARTMENT FLOODING SUMMARY

At 0.6oS Heel	PERM.	FLOODED WTR LTons	% FULL (Damaged)	% FULL (Intact)	SP.VOL. ft ³ /LT	OUTFLO LTons
VOID1	0.95	67.9	FREE	0.0	----	----
BALLAST1	0.95	47.1	FREE	0.0	----	----
BOWTHRUST	0.95	72.1	FREE	0.0	----	----
FO #1 S	0.95	35.5	FREE	100.0	40.6000	42.4
Totals		222.6				42.4

INTACT DATA

Draft at AP = 6.960 ft Kmt = 87.822 ft LCG = 95.282A ft-FP
 Draft at FP = 6.210 ft VCG = 16.470 ft LCB = 95.330A ft-FP
 Displacement = 1453.8 LTons GMT = 71.352 ft TCG = 0.000 ft-CL

DRAFT/GZ DATA

HEEL degrees	RIGHTING ARM ft	DRAFT AFT ft	DRAFT FWD ft	FLOODED WATER LTons
0.00	-0.698	6.158	8.037	216.8
5.00S	4.373	5.694	8.634	269.5
7.00S	5.742	5.312	9.040	284.2
10.00S	6.676	4.644	9.918	299.3
20.00S	6.111	2.411	13.826	321.3
30.00S	3.975	-0.244	18.915	331.8
40.00S	1.444	-3.642	25.482	338.4
50.00S	-1.211	-8.391	34.530	342.7
60.00S	-3.838	-15.580	48.269	345.2

Note: Drafts are measured at A.P. and F.P along ship's centerline

GZ SUMMARY (Evaluated per IMO (SOLAS'90) Rules for Passenger Ships)

	Available	Required
Static Heel Angle	0.64S deg	7.00 deg
Angle at Maximum GZ	14.00S deg	
Maximum GZ	6.904 ft	1.500 ft
Range of Positive GZ	44.81 deg	15.00 deg
Righting Area (0.64-1.00)	117.605 ft-deg	2.820 ft-deg

DPTB015B:
 192' FERRY

aged Compartments:

	BALLAST1	BOWTHRUST	FO #1 S	BALLAST2	FO #2 S		
	DISPLACEMENT	DRAFT AFT	DRAFT FWD	TRIM	HEEL	UPRIGHT	GMT
	Ltons	ft	ft	ft	deg.	ft	
INTACT	1,453.8	6.960	6.210	0.750A	0.00	71.352	
DAMAGED	1,566.6	6.506	7.321	0.815F	0.91S	64.706	

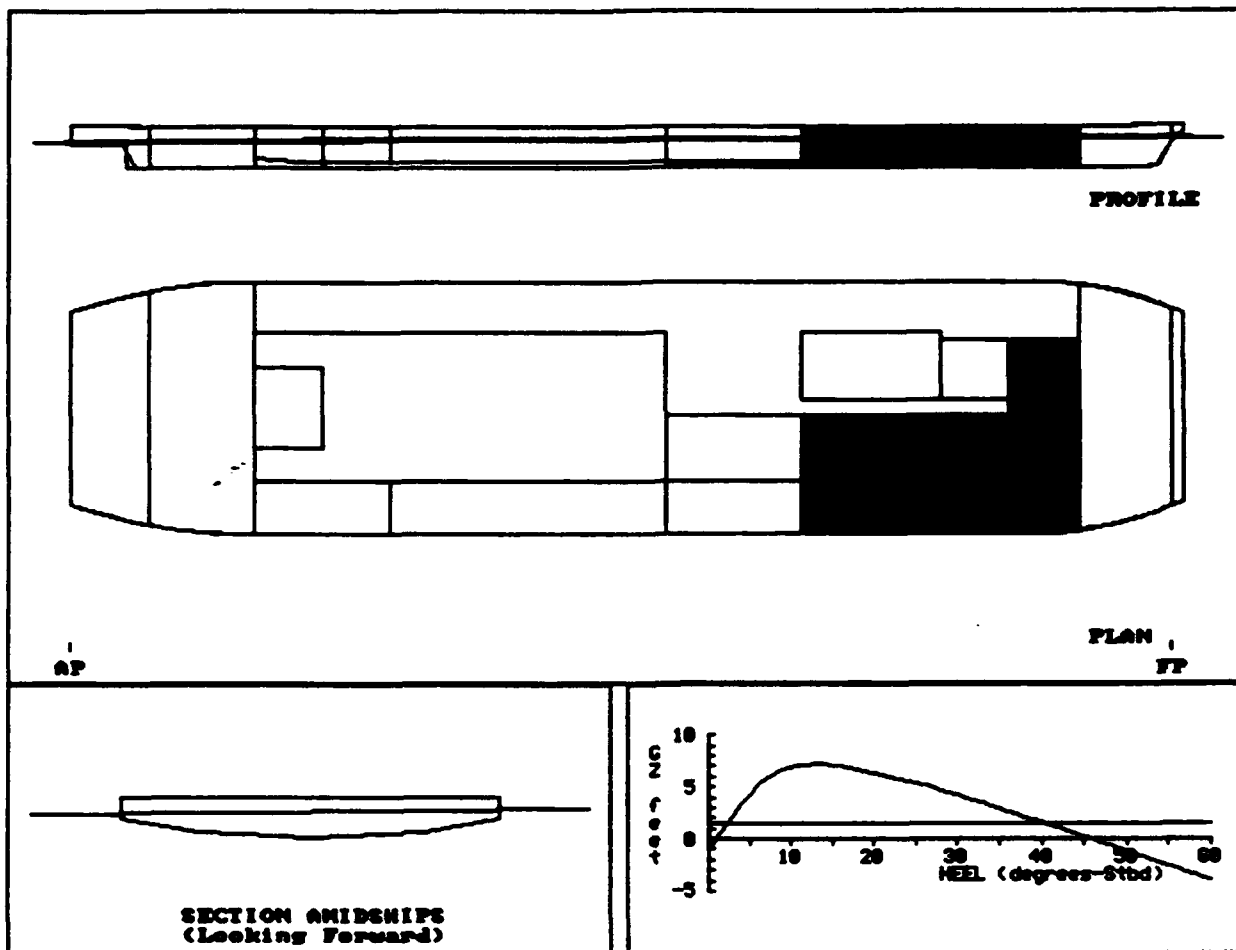

DPTB015B:
 192' FERRY

COMPARTMENT FLOODING SUMMARY

At 0.9oS Heel	PERM.	FLOODED WTR LTons	% FULL (Damaged)	% FULL (Intact)	SP.VOL. ft ³ /LT	OUTFLO LTons
BALLAST1	0.95	42.2	FREE	0.0	----	----
BOWTHRUST	0.95	64.7	FREE	0.0	----	----
FO #1 S	0.95	32.9	FREE	100.0	40.6000	42.4
BALLAST2	0.95	37.4	FREE	0.0	----	----
FO #2 S	0.95	73.6	FREE	100.0	40.6000	95.7
Totals		250.8				138.0

INTACT DATA

Draft at AP = 6.960 ft KMT = 87.822 ft LCG = 95.282A ft-FP
 Draft at FP = 6.210 ft VCG = 16.470 ft LCB = 95.330A ft-FP
 Displacement = 1453.8 LTons GMT = 71.352 ft TCG = 0.000 ft-CL

DRAFT/GZ DATA

HEEL degrees	RIGHTING ARM ft	DRAFT AFT ft	DRAFT FWD ft	FLOODED WATER LTons
0.00	-1.028	6.560	7.200	236.4
5.00S	4.292	6.210	7.863	315.3
7.00S	5.838	5.927	8.139	338.8
10.00S	6.918	5.467	8.740	358.9
20.00S	6.412	4.087	11.501	380.9
30.00S	4.235	2.649	14.853	384.0
40.00S	1.598	0.857	19.129	385.6
50.00S	-1.187	-1.506	24.929	386.6
60.00S	-3.974	-5.074	33.809	387.2

Note: Drafts are measured at A.P. and F.P along ship's centerline

GZ SUMMARY (Evaluated per IMO (SOLAS'90) Rules for Passenger Ships)

	Available	Required
Static Heel Angle	0.91S deg	7.00 deg
Angle at Maximum GZ	14.00S deg	
Maximum GZ	7.202 ft	1.500 ft
Range of Positive GZ	44.85 deg	15.00 deg
Righting Area (0.91- \pm .00)	120.873 ft-deg	2.820 ft-deg

DPTB016B:
 192' FERRY

Damaged Compartments:

	BALLAST2	FO #2 S	BALLAST3	VOID2			
	DISPLACEMENT	DRAFT AFT	DRAFT FWD	TRIM	HEEL	UPRIGHT GMT	
	Ltons	ft	ft	ft	deg.	ft	
INTACT	1,453.8	6.960	6.210	0.750A	0.00	71.352	
DAMAGED	1,578.0	7.028	6.858	0.170A	1.33S	63.330	

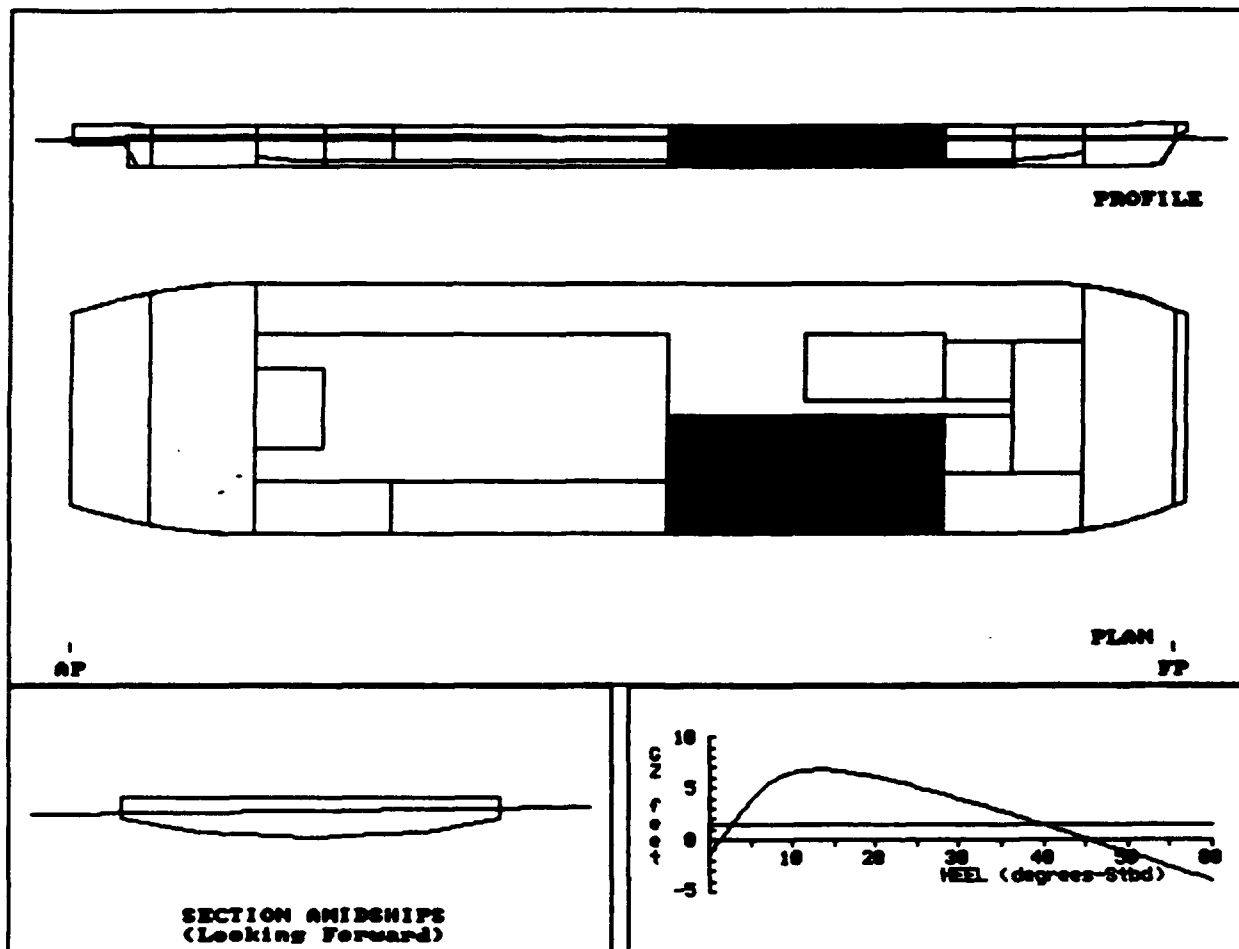

DPTB016B:
 192' FERRY

COMPARTMENT FLOODING SUMMARY

At 1.3oS Heel	PERM.	FLOODED WTR LTons	% FULL (Damaged)	% FULL (Intact)	SP.VOL. ft ³ /LT	OUTFLOW LTons
BALLAST2	0.95	37.4	FREE	0.0	----	----
FO #2 S	0.95	72.3	FREE	100.0	40.6000	95.7
BALLAST3	0.95	37.6	FREE	0.0	----	----
VOID2	0.95	72.5	FREE	0.0	----	----
Totals		219.8				95.7

INTACT DATA

Draft at AP = 6.960 ft Vmt = 87.822 ft LCG = 95.282A ft-FP
 Draft at FP = 6.210 ft VCG = 16.470 ft LCB = 95.330A ft-FP
 Displacement = 1453.8 LTons GMT = 71.352 ft TCG = 0.000 ft-CL

DRAFT/GZ DATA

HEEL degrees	RIGHTING ARM ft	DRAFT AFT ft	DRAFT FWD ft	FLOODED WATER LTons
0.00	-1.480	7.029	6.754	200.5
5.00S	3.861	6.971	7.127	271.4
7.00S	5.470	6.833	7.235	295.5
10.00S	6.554	6.709	7.498	317.5
20.00S	6.080	6.670	9.038	345.5
30.00S	4.000	6.807	10.913	350.0
40.00S	1.486	6.970	13.240	350.1
50.00S	-1.185	7.208	16.415	350.1
60.00S	-3.867	7.612	21.285	350.1

Note: Drafts are measured at A.P. and F.P along ship's centerline

GZ SUMMARY (Evaluated per IMO (SOLAS'90) Rules for Passenger Ships)
 Available Required

Static Heel Angle	1.33S deg	7.00 deg
Angle at Maximum GZ	14.00S deg	
Maximum GZ	6.832 ft	1.500 ft
Range of Positive GZ	44.26 deg	15.00 deg
Righting Area (1.33-7.00)	112.961 ft-deg	2.820 ft-deg

DPTB017B:
 192' FERRY

aged Compartments:

BALLAST3 VOID2 BALLAST4

	DISPLACEMENT LTons	DRAFT AFT ft	DRAFT FWD ft	TRIM ft	HEEL deg.	UPRIGHT Gmt ft
INTACT	1,453.8	6.960	6.210	0.750A	0.00	71.352
DAMAGED	1,662.9	7.454	6.918	0.536A	2.28S	56.091

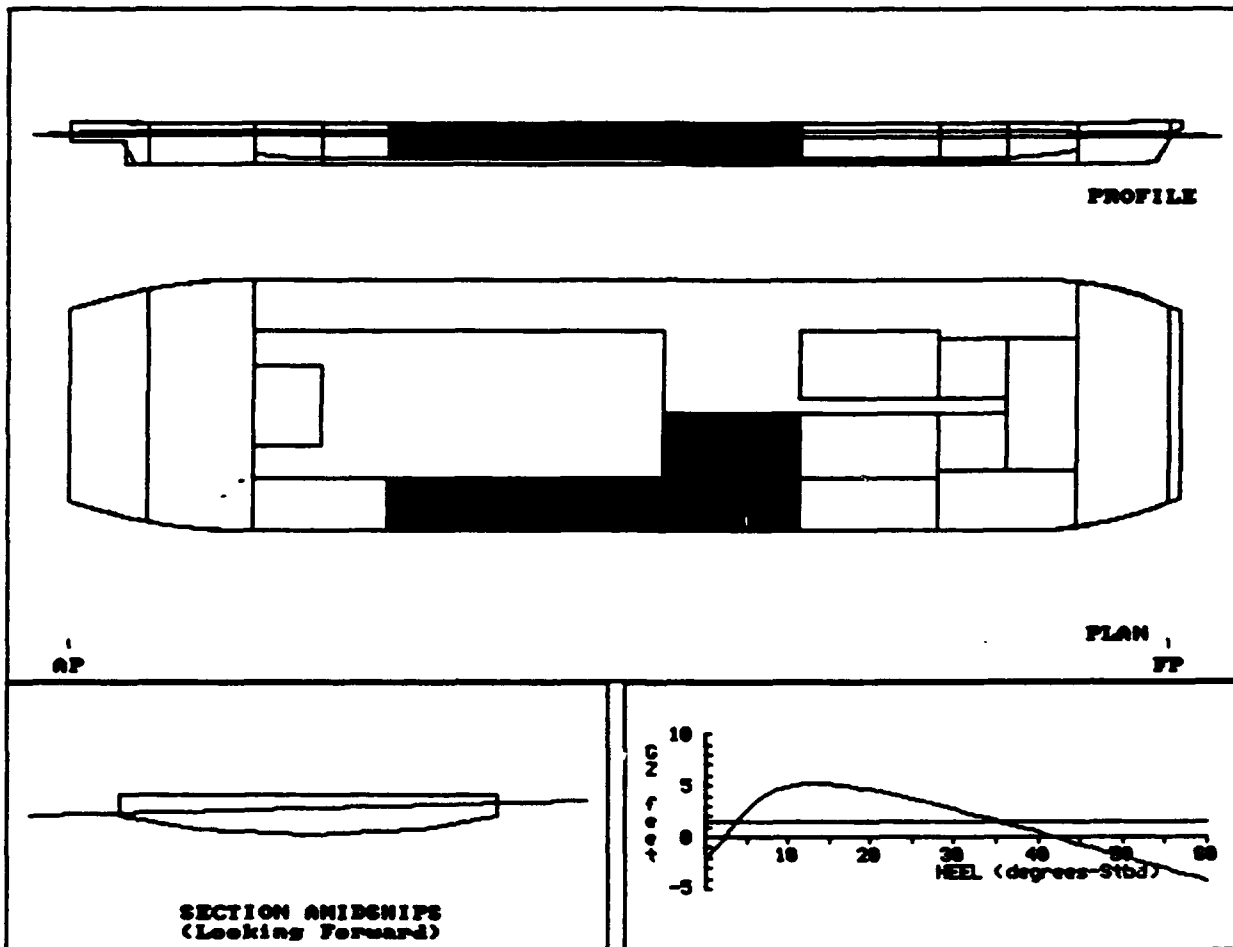

DPTB017B:
 192' FERRY

COMPARTMENT FLOODING SUMMARY

At 2.3oS Heel	PERM.	FLOODED WTR LTons	% FULL (Damaged)	% FULL (Intact)	SP.VOL. ft ³ /LT	OUTFLC LTons
BALLAST3	0.95	43.2	FREE	0.0	----	----
VOID2	0.95	76.8	FREE	0.0	----	----
BALLAST4	0.95	89.0	FREE	0.0	----	----
Totals		209.0				

INTACT DATA

Draft at AP = 6.960 ft	KMt = 87.822 ft	LCG = 95.282A ft-FP
Draft at FP = 6.210 ft	VCG = 16.470 ft	LCB = 95.330A ft-FP
Displacement = 1453.8 LTons	GMT = 71.352 ft	TCG = 0.000 ft-CL

DRAFT/GZ DATA

HEEL degrees	RIGHTING ARM ft	DRAFT AFT ft	DRAFT FWD ft	FLOODED WATER LTons
0.00	-2.276	7.334	6.834	172.8
5.00S	2.532	7.572	6.983	251.5
7.00S	3.958	7.625	6.975	275.9
10.00S	4.939	7.795	7.029	289.3
20.00S	4.573	8.821	7.762	302.1
30.00S	2.717	10.240	8.781	304.5
40.00S	0.480	12.034	10.041	304.5
50.00S	-1.878	14.478	11.773	304.5
60.00S	-4.222	18.228	14.468	304.5

Note: Drafts are measured at A.P. and F.P along ship's centerline

GZ SUMMARY (Evaluated per IMO (SOLAS'90) Rules for Passenger Ships)

	Available	Required
Static Heel Angle	2.28S deg	7.00 deg
Angle at Maximum GZ	14.00S deg	
Maximum GZ	5.208 ft	1.500 ft
Range of Positive GZ	39.77 deg	15.00 deg
Righting Area (2.28-1.00)	82.768 ft-deg	2.820 ft-deg

DPTB018B:
 192' FERRY

Damaged Compartments:

	BALLAST3	VOID2	BALLAST4	ENG ROOM			
	DISPLACEMENT	DRAFT AFT	DRAFT FWD	TRIM	HEEL	UPRIGHT	GMT
	Ltons	ft	ft	ft	deg.	ft	ft
INTACT	1,453.8	6.960	6.210	0.750A	0.00	71.352	
DAMAGED	2,303.3	11.425	7.180	4.244A	4.97S	51.596	

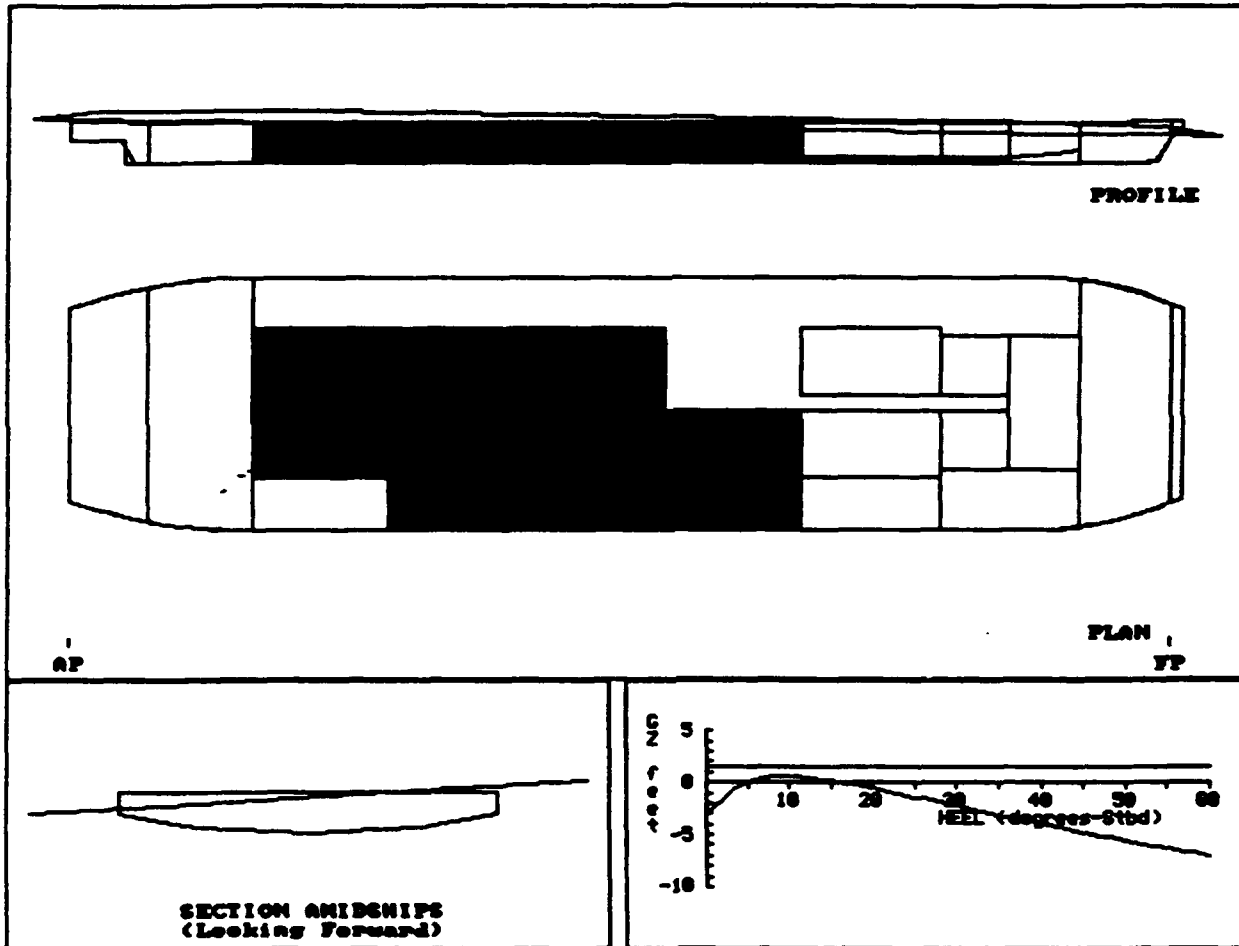

DPTB018B:
 192' FERRY

COMPARTMENT FLOODING SUMMARY

At 5.0oS Heel	PERM.	FLOODED WTR LTons	% FULL (Damaged)	% FULL (Intact)	SP.VOL. ft3/LT	OUTFLC LTons
BALLAST3	0.95	64.0	FREE	0.0	----	----
VOID2	0.95	102.3	FREE	0.0	----	----
BALLAST4	0.95	129.5	FREE	0.0	----	----
ENG ROOM	0.85	553.7	FREE	0.0	----	----
Totals		849.4				

INTACT DATA

Draft at AP = 6.960 ft Kmt = 87.822 ft LCG = 95.282A ft-FP
 Draft at FP = 6.210 ft VCG = 16.470 ft LCB = 95.330A ft-FP
 Displacement = 1453.8 LTons GMT = 71.352 ft TCG = 0.000 ft-CL

DRAFT/GZ DATA

HEEL degrees	RIGHTING ARM ft	DRAFT AFT ft	DRAFT FWD ft	FLOODED WATER LTons
0.00	-3.203	10.203	7.249	752.6
5.00S	0.014	11.437	7.179	849.7
7.00S	0.446	12.448	7.089	867.1
10.00S	0.563	14.150	7.053	882.7
20.00S	-0.535	20.640	7.292	899.5
30.00S	-2.223	28.613	7.623	907.3
40.00S	-3.939	38.434	8.106	909.8
50.00S	-5.572	51.710	8.831	911.1
60.00S	-7.042	71.742	10.204	911.9

Note: Drafts are measured at A.P. and F.P along ship's centerline

GZ SUMMARY (Evaluated per IMO (SOLAS'90) Rules for Passenger Ships)

	Available	Required
Static Heel Angle	4.97S deg	7.00 deg
Angle at Maximum GZ	10.00S deg	
*** Maximum GZ	0.569 ft	1.500 ft
*** Range of Positive GZ	11.49 deg	15.00 deg
*** Righting Area (4.97-11.46)	4.342 ft-deg	2.820 ft-deg

*** indicates failure to meet criterion

DPTB019B:
 192' FERRY

Waged Compartments:

BALLAST4 ENG ROOM BALLAST5

	DISPLACEMENT LTONS	DRAFT AFT ft	DRAFT FWD ft	TRIM ft	HEEL deg.	UPRIGHT GMT ft
INTACT	1,453.8	6.960	6.210	0.750A	0.00	71.352
DAMAGED	2,181.4	11.382	6.211	5.171A	3.61S	51.757

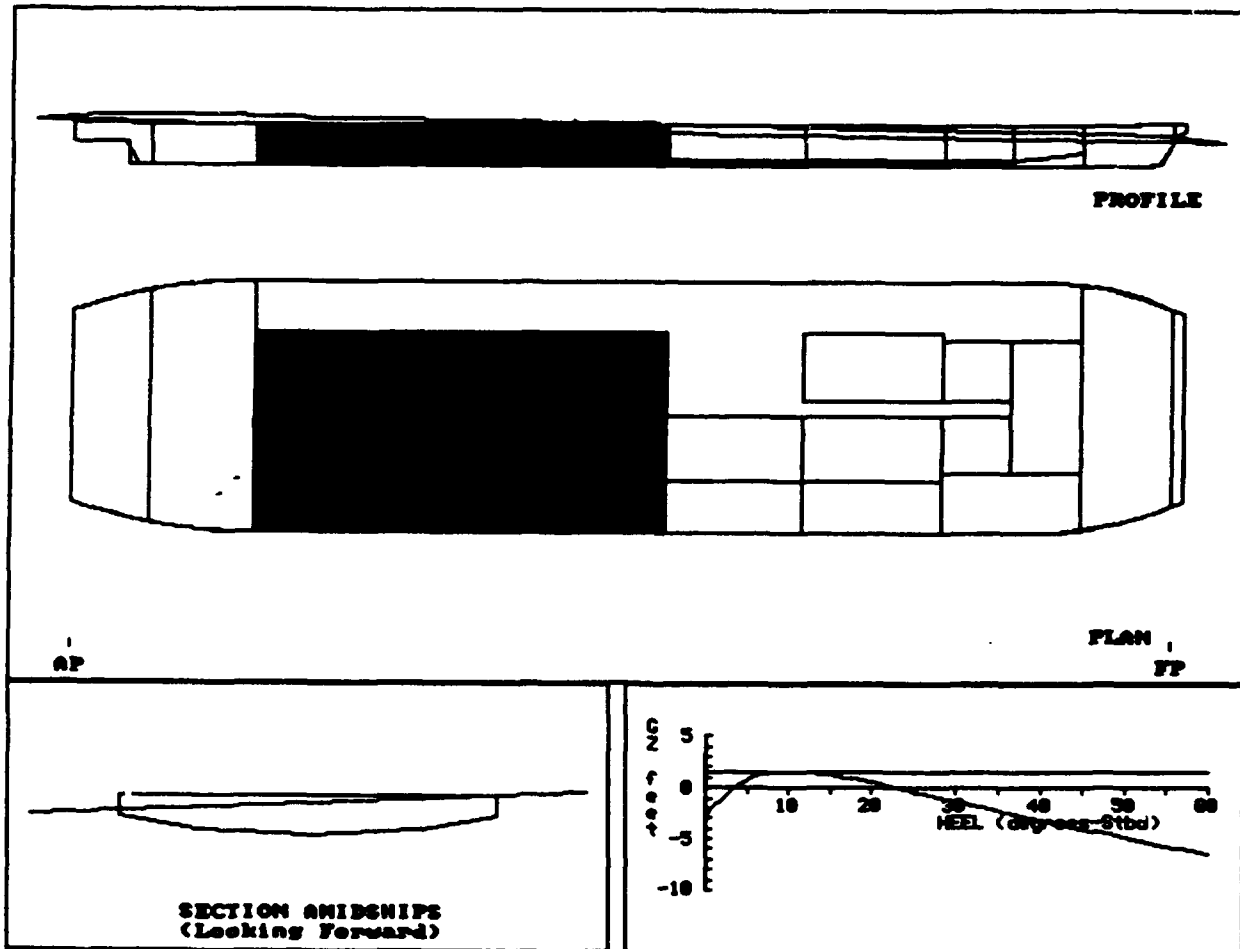

DPTB019B:
 192' FERRY

COMPARTMENT FLOODING SUMMARY

At 3.6oS Heel	PERM.	FLOODED WTR LTons	% FULL (Damaged)	% FULL (Intact)	SP.VOL. ft3/LT	OUTFLO LTons
BALLAST4	0.95	128.2	FREE	0.0	----	----
ENG ROOM	0.85	536.4	FREE	0.0	----	----
BALLAST5	0.95	62.9	FREE	0.0	----	----
Totals		727.6				

INTACT DATA

Draft at AP = 6.960 ft	KMt = 87.822 ft	LCG = 95.282A ft-FP
Draft at FP = 6.210 ft	VCG = 16.470 ft	LCB = 95.330A ft-FP
Displacement = 1453.8 LTons	Gmt = 71.352 ft	TCG = 0.000 ft-CL

DRAFT/GZ DATA

HEEL degrees	RIGHTING ARM ft	DRAFT AFT ft	DRAFT FWD ft	FLOODED WATER LTons
0.00	-2.688	10.481	6.451	664.6
5.00S	0.714	11.891	6.066	739.2
7.00S	1.320	12.973	5.756	751.6
10.00S	1.582	14.881	5.313	765.1
20.00S	0.568	22.282	4.061	784.1
30.00S	-1.207	31.410	2.633	791.3
40.00S	-3.068	42.852	0.887	794.4
50.00S	-4.855	58.243	-1.356	796.1
60.00S	-6.479	81.192	-4.417	796.8

Note: Drafts are measured at A.P. and F.P along ship's centerline

GZ SUMMARY (Evaluated per IMO (SOLAS'90) Rules for Passenger Ships)

	Available	Required
Static Heel Angle	3.61S deg	7.00 deg
Angle at Maximum GZ	11.00S deg	
Maximum GZ	1.582 ft	1.500 ft
Range of Positive GZ	19.73 deg	15.00 deg
Righting Area (3.61-11.00)	20.069 ft-deg	2.820 ft-deg

DPTB020B:
 192' FERRY

aged Compartments:

ENG ROOM BALLASTS VOID3

	DISPLACEMENT LTons	DRAFT AFT ft	DRAFT FWD ft	TRIM ft	HEEL deg.	UPRIGHT GMT ft
INTACT	1,453.8	6.960	6.210	0.750A	0.00	71.352
DAMAGED	2,181.4	0.000	0.000	0.000	0.00	51.757

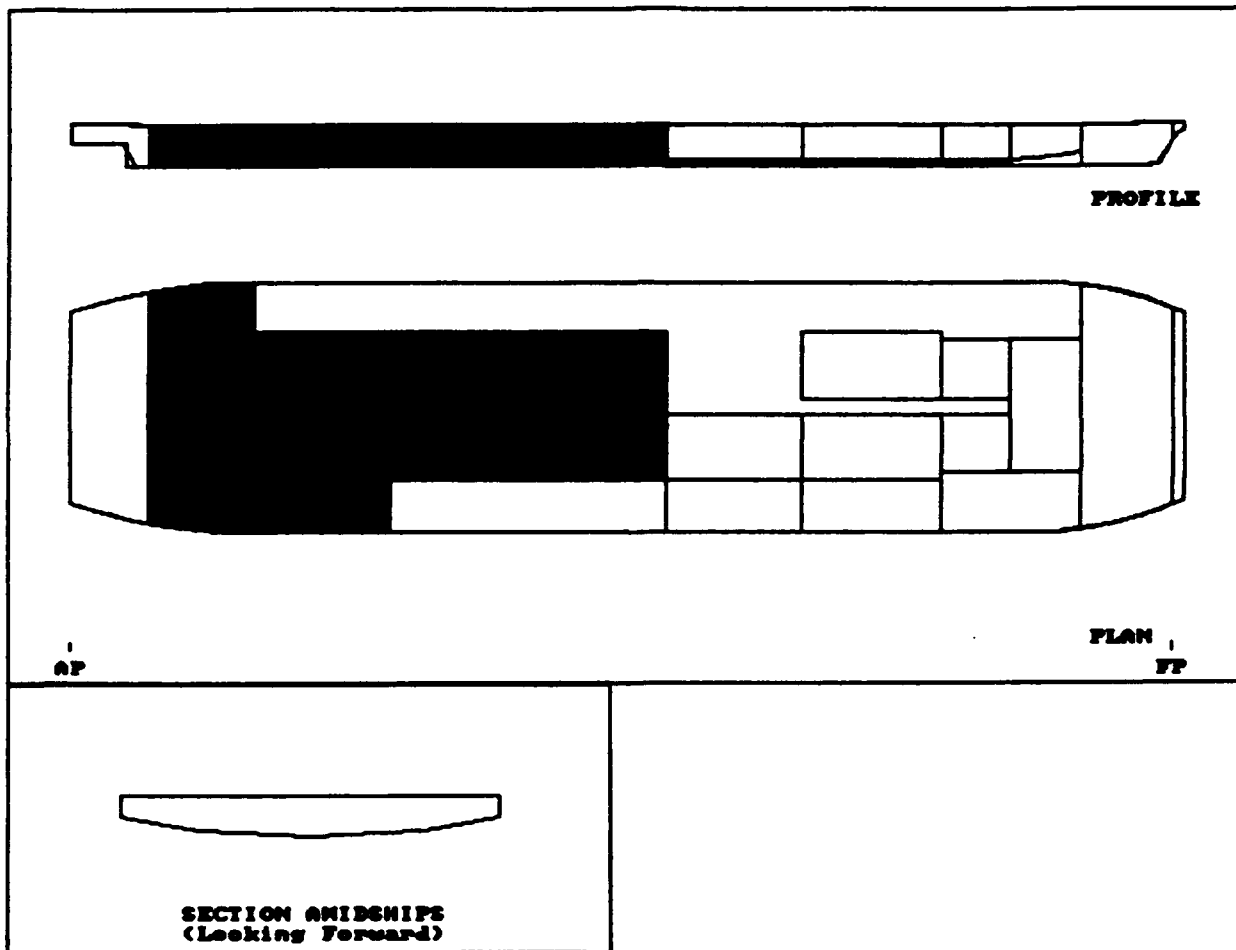

DPTB020B:
192' FERRY

COMPARTMENT FLOODING SUMMARY

At 0.0o Heel	PERM.	FLOODED WTR LTons	% FULL (Damaged)	% FULL (Intact)	SP.VOL. ft3/LT	OUTFLC LTons
ENG ROOM	0.85	XXXXX	FREE	0.0	----	----
BALLAST5	0.95	XXXXX	FREE	0.0	----	----
VOID3	0.95	XXXXX	FREE	0.0	----	----
Totals		XXXXX				

INTACT DATA

Draft at AP = 6.960 ft KMt = 87.822 ft LCG = 95.282A ft-FP
Draft at FP = 6.210 ft VCG = 16.470 ft LCB = 95.330A ft-FP
Displacement = 1453.8 LTons GMT = 71.352 ft TCG = 0.000 ft-CL

--- Vessel is Longitudinally Unstable ---
(Unable to Complete Calculations)