



PB94-102480



U. S. Department  
of Transportation  
Federal Railroad  
Administration

# Safety of High Speed Guided Ground Transportation Systems

Office of Research  
and Development  
Washington, D.C. 20590

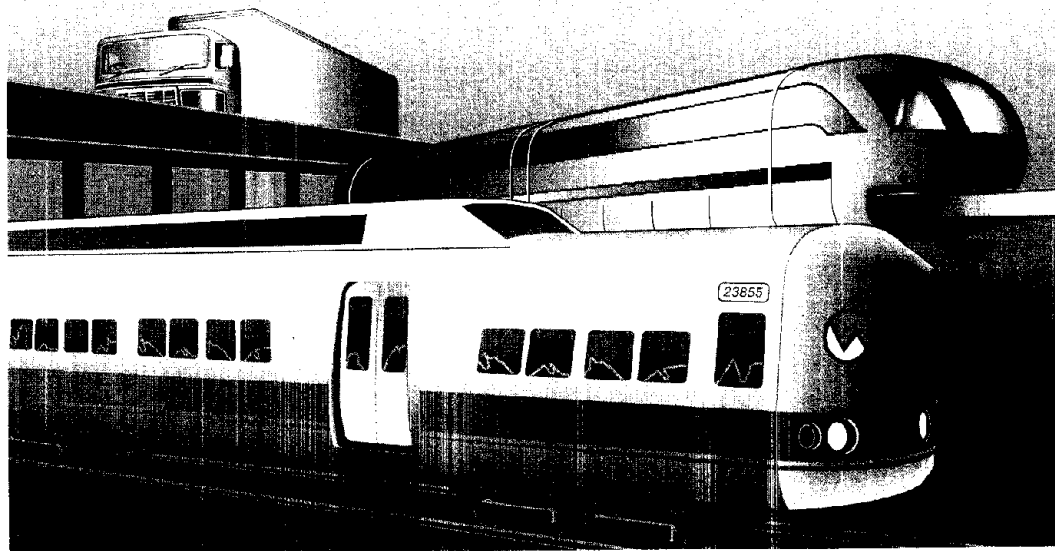

DOT/FRA/ORD-93/04.II  
DOT-VNTSC-FRA-93-8.II

Final Report  
June 1993

This document is available to the  
public through the National Technical  
Information Service, Springfield, VA 22161

### NOTICE

This document is disseminated under the sponsorship of the Department of Transportation in the interest of information exchange. The United States Government assumes no liability for its contents or use thereof.

### NOTICE

The United States Government does not endorse products or manufacturers. Trade or manufacturers' names appear herein solely because they are considered essential to the object of this report.

### NOTICE

In places, this report discusses whether various aspects of the technology that is the subject of this report comply with Federal safety laws and regulations. Those discussions, which reflect the seasoned judgement of commentators qualified in their fields, do not constitute rulings by the Federal Railroad Administration's Office of Safety or its Office of Chief Counsel concerning compliance with the law.

# REPORT DOCUMENTATION PAGE

Form Approved  
OMB No. 0704-0188

Public reporting burden for this collection of information is estimated to average 1 hour per response, including the time for reviewing instructions, searching existing data sources, gathering and maintaining the data needed, and completing and reviewing the collection of information. Send comments regarding this burden estimate or any other aspect of this collection of information, including suggestions for reducing this burden, to Washington Headquarters Services, Directorate for Information Operations and Reports, 1215 Jefferson Davis Highway, Suite 1204, Arlington, VA 22202-4302, and to the Office of Management and Budget, Paperwork Reduction Project (0704-0188), Washington, DC 20503.

1.  PB94-102480		2. REPORT DATE June 1993	3. REPORT TYPE AND DATES COVERED Final Report September 1992 - March 1993	
4. TITLE AND SUBTITLE Safety of High Speed Guided Ground Transportation Systems: Magnetic and Electric Field Testing of the Washington Metropolitan Transit (WMATA) System Volume II - Appendices			5. FUNDING NUMBERS R3010/RR393	
6. AUTHOR(S) William L. Jacobs, Fred M. Dietrich *				
7. PERFORMING ORGANIZATION NAME(S) AND ADDRESS(ES) Electric Research and Management, Inc. P.O. Box 165 State College, PA 16804			8. PERFORMING ORGANIZATION REPORT NUMBER DOT-VNTSC-FRA-93-8.11	
9. SPONSORING/MONITORING AGENCY NAME(S) AND ADDRESS(ES) U.S. Department of Transportation Federal Railroad Administration Office of Research and Development Washington, D.C. 20590			10. SPONSORING/MONITORING AGENCY REPORT NUMBER DOT/FRA/ORD-93/04.11	
11. SUPPLEMENTARY NOTES U.S. Department of Transportation Research and Special Programs Administration * Under contract to: John A. Volpe National Transportation Systems Center Kendall Square, Cambridge, MA 02142				
12a. DISTRIBUTION/AVAILABILITY STATEMENT This document is available to the public through the National Technical Information Service, Springfield, VA 22161			12b. DISTRIBUTION CODE	
13. ABSTRACT (Maximum 200 words) The safety of magnetically levitated (maglev) and high speed rail (HSR) trains proposed for application in the United States is the responsibility of the Federal Railroad Administration (FRA). Plans for near future US applications include maglev technology (e.g. in Orlando, FL and Pittsburgh, PA) and high speed rail (e.g. the French Train a Grande Vitesse (TGV) in the Texas Triangle, between Dallas-Fort Worth, Houston and San Antonio, and along five designated high speed corridors). Concerns exist regarding the potential safety, environmental and health effects on the public and on transportation workers due to electrification along new or existing rail corridors, and to maglev and high speed rail operations. Therefore, the characterization of electric and magnetic fields (EMF) produced by both steady (dc) and alternating currents (ac) at power frequency (50 Hz in Europe and 60 Hz in the U.S.) and above, in the Extreme Low Frequency (ELF) range (3-3000 Hz) is of interest. An EMF survey of the Washington Metrorail (WMATA) transit system was performed, as part of a comprehensive comparative EMF safety assessment of the German Transrapid (TR-07) maglev system with other existing and advanced rail systems. This report provides the Analysis (Vol. I) of results, and detailed data and statistical summaries (Vol. II, Appendices) of representative EMF profiles on vehicles and facilities typical of this transit electrotechnology (third rail dc). EMF data represent a range of train operating conditions and locations (in vehicles, stations and waysides), as well as in traffic control and electrical power supply facilities. A portable magnetic field monitoring system (augmented to include an electric fields probe) was used to sample, record and store 3 axis static and ac magnetic fields waveforms simultaneously, at multiple locations. A real time Digital Audio Tape (DAT) recorder able to capture EMF transients, and two personal power-frequency magnetic field monitors were used to collect complementary data. The statistical and Fourier analysis of results enable a comparative characterization of EMF intensities, and spatial and temporal variability, by frequency band, and by distance from the source. While dc fields recorded at some locations are above the normal range, EMF ELF levels for WMATA are comparable to those produced by common environmental sources at home, work, and under power lines, but have specific frequency signatures, and are more variable in time.				
14. SUBJECT TERMS Electric and Magnetic Fields (EMF); Static (dc) Magnetic Field; Alternating Field (ac); Extremely Low Frequency (ELF); Washington Metropolitan Area Transit Authority (WMATA); Rapid Rail Transit; Transit; Third Rail; Traffic Control Center; Passenger Stations; Power Substations; Power Frequency (PF); Harmonics; Transients; Fourier Analysis; EMDEX Personal Magnetic Field Exposure Monitor; Digital Audio Tape (DAT) Recorder; MultiWave Magnetic Field Recording System.			15. NUMBER OF PAGES 546	
			16. PRICE CODE	
17. SECURITY CLASSIFICATION OF REPORT Unclassified	18. SECURITY CLASSIFICATION OF THIS PAGE Unclassified	19. SECURITY CLASSIFICATION OF ABSTRACT Unclassified	20. LIMITATION OF ABSTRACT	

NSN 7540-01-280-5500

PROTECTED UNDER INTERNATIONAL COPYRIGHT  
ALL RIGHTS RESERVED.  
NATIONAL TECHNICAL INFORMATION SERVICE  
U.S. DEPARTMENT OF COMMERCE

Standard Form 298 (Rev. 2-89)  
Prescribed by ANSI Std. Z39-18  
298-102

**SYSTÈME INTERNATIONAL (SI) UNIT DEFINITIONS AND  
CONVERSIONS USED IN THIS REPORT**

**DISTANCE (ENGLISH-TO-SI CONVERSION):**

1 inch (in)	= 2.54 centimeters (cm)	= 0.025 meters (m)
1 foot (ft)	= 30.5 centimeters (cm)	= 0.305 meters (m)
1 yard (yd)	= 91.4 centimeters (cm)	= 0.914 meters (m)
1 mile (mi)	= 1.61 kilometers (km)	= 1,610 meters (m)

**ELECTRICAL QUANTITIES:**

**Electric Fields**

1 Volt/meter (V/m)	= 0.01 Volts/centimeter (V/cm)
1 kiloVolt/meter (kV/m)	= 1000 Volts/meter (V/m)
1 kiloVolt/meter (kV/m)	= 10 Volts/centimeter (V/cm)

**Magnetic Flux Densities (English-to-SI Conversion)**

10,000 Gauss (G)	= 1 Tesla (T)
10 milliGauss (mG)	= 1 microTesla ( $\mu$ T)
1 milliGauss (mG)	= .1 microTesla ( $\mu$ T)
0.01 milliGauss (mG)	= 1 nanoTesla (nT)

**Electromagnetic Frequency Bands**

1 cycle per second	= 1 Hertz (Hz)
1,000 cycles per second	= 1 kiloHertz (kHz)
Ultra Low Frequency (ULF) Band	= 0 Hz to 3 Hz
Extreme Low Frequency (ELF) Band	= 3 Hz to 3 kHz
Very Low Frequency (VLF) Band	= 3 kHz to 30 kHz
Low Frequency (LF) Band	= 30 kHz to 300 kHz

## PREFACE

The Federal Railroad Administration (FRA) has undertaken a series of studies to facilitate the introduction of advanced high speed guided ground transportation (HSGGT) technology to the U.S., including both magnetic levitation (maglev) and steel wheel on rail high speed alternatives, such as the French Train a Grande Vitesse (TGV), the Swedish Tilt Train (X2000), or the German Intercity Express (ICE). HSGGT technology options can be expected to undergo detailed public scrutiny and environmental assessment in order to convincingly establish their safety.

Timely development of technical information required for rulemaking initiatives is needed to ensure the public safety. An emerging concern related to environmental, workers', and to public health and safety is that of potentially adverse health effects of extra-low frequency (ELF) electric and magnetic fields (EMF) commonly associated with power transmission and distribution lines. Magnetic fields are of greater concern than electric fields, because they are pervasive, penetrate biological tissues without attenuation, and are more difficult to shield. Although no federal standards and guidelines on EMF/ELF exposure of workers and the public exist at present, international, state and professional associations have issued interim guidelines.

To enable informed assessments and comparisons to be made amongst emerging and existing technologies, a thorough EMF characterization (frequency, intensity, spatial and temporal variability, source analysis) of all representative existing and advanced electrical transportation systems is needed. This report is one of a comprehensive series of studies and reports addressing the ELF EMF safety issues for candidate HSGGT technologies and systems.

Electric Research and Management, Inc. (ERM) was engaged to measure, characterize and analyze the EMF for representative existing and advanced rail and transit systems.

This report presents data on both static (dc) and alternating (ac) magnetic fields and on ac electric fields obtained on the Washington Metropolitan Area Transit Authority (WMATA) system. Volume I, Analysis presents a summary of representative EMF data on transit system vehicles and facilities, over a full range of operating conditions, as well as their variability in time, space and frequency. A comparison of transit system magnetic field strengths with power frequency EMF produced by home appliances and common electric power distribution and transmission lines is also provided. Volume II, Appendices contains detailed EMF data files arranged by location, time, and frequency range, as well as statistics.

This report was prepared by a team of ERM personnel designated as authors for each volume, led by Fred M. Dietrich, Program Manager and William E. Feero, President. The technical monitor for this task and for the entire series of reports characterizing ELF and EMF for rail technologies was Dr. Aviva Brecher of the DOT/RSPA John A. Volpe National Transportation Systems Center (Volpe Center) who manages the FRA's EMF Research Program. Guidance and program support was provided by Robert Dorer, the HSGGT Safety Program Manager at the Volpe Center. Professor Ross Holmstrom of University of Massachusetts and Volpe Center assisted both in planning the measurements and reviewing the results. Arne Bang, Senior Manager of Special Programs and the FRA sponsor for this work is thanked for overall direction and oversight.

Mr. Ronald D. Kangas and Jeffrey G. Mora from the Federal Transit Administration's Office of Technical Assistance and Safety provided technical advice and review comments. Valuable assistance with the measurements and logistics, as well as review comments on the draft report were provided by Mr. Joseph F. Krempasky, Vehicle Engineering, Department of Rail Service at WMATA.

VOLUME I  
TABLE OF CONTENTS

Section	Page
1. EXECUTIVE SUMMARY . . . . .	1-1
1.1 Background . . . . .	1-1
1.2 Measurement Approach . . . . .	1-1
1.3 Summary of Metrorail Field Levels . . . . .	1-4
1.3.1 Metrorail Cars . . . . .	1-4
1.3.2 Operator's Compartment . . . . .	1-4
1.3.3 Metrorail Waysides . . . . .	1-5
1.3.4 Passenger Station Platforms . . . . .	1-6
1.3.5 Traction Power Supply Stations . . . . .	1-6
1.3.6 Control Facilities . . . . .	1-7
1.4 Comparison of Metrorail Fields to Other Electro-Technologies . . . . .	1-7
1.4.1 Static Fields . . . . .	1-7
1.4.2 Frequency Spectrum . . . . .	1-8
1.4.3 Time Characteristics . . . . .	1-8
1.4.4 Amplitude Characteristics . . . . .	1-8
1.4.4.1 Metrorail Cars . . . . .	1-8
1.4.4.2 Operator's Compartment . . . . .	1-11
1.4.4.3 Along the Wayside . . . . .	1-11
1.4.4.4 Passenger Stations . . . . .	1-11
1.4.4.5 Power Supply System Measurements . . . . .	1-11
1.4.4.6 Control Areas . . . . .	1-11
1.5 Conclusions . . . . .	1-17
2. OVERVIEW . . . . .	2-1
2.1 Report Organization . . . . .	2-1
2.2 Background . . . . .	2-2
2.2.1 Natural Magnetic Field Characteristics . . . . .	2-2
2.2.2 Technological Magnetic Field Perturbations . . . . .	2-3
2.2.3 Electric and Magnetic Fields and Biological Effects . . . . .	2-3
2.3 The WMATA Metrorail System . . . . .	2-5
2.4 An Approach to Organizing Electromagnetic Data . . . . .	2-6
2.5 Instrumentation . . . . .	2-7

VOLUME I  
TABLE OF CONTENTS (CONT'D)

Section	Page
2.5.1 Portable Waveform Capture System . . . . .	2-9
2.5.2 Digital Audio Tape Recorder . . . . .	2-9
2.5.3 EMDEX-II Recorders . . . . .	2-9
2.6 Repetitive Waveform Data . . . . .	2-10
2.7 DAT Waveform Data . . . . .	2-19
2.8 RMS Recorder Data . . . . .	2-19
3. MEASUREMENTS ONBOARD CAR . . . . .	3-1
3.1 Measurement Locations . . . . .	3-1
3.2 Repetitive Waveform Datasets . . . . .	3-3
3.3 Magnetic Field Characteristics . . . . .	3-5
3.4 DAT Waveform Data . . . . .	3-23
3.5 RMS Recorder Data . . . . .	3-27
3.6 Summary of Onboard Magnetic Field Levels . . . . .	3-27
3.7 Summary of Electric Field Sources and Levels . . . . .	3-38
4. MEASUREMENTS IN THE OPERATOR'S COMPARTMENT . . . . .	4-1
4.1 Measurement Locations . . . . .	4-1
4.2 Repetitive Waveform Datasets . . . . .	4-1
4.3 Magnetic Field Characteristics . . . . .	4-2
4.4 DAT Waveform Data . . . . .	4-2
4.5 RMS Recorder Data . . . . .	4-2
4.6 Summary of Magnetic Field Levels . . . . .	4-2
4.7 Summary of Electric Field Sources and Levels . . . . .	4-8
5. MEASUREMENTS ALONG THE WAYSIDE . . . . .	5-1
5.1 Measurement Locations . . . . .	5-1
5.2 Repetitive Waveform Datasets . . . . .	5-1
5.3 Magnetic Field Characteristics . . . . .	5-4
5.3.1 At Underpass . . . . .	5-4
5.3.2 At An Open Space . . . . .	5-7
5.4 DAT Waveform Data . . . . .	5-9
5.5 Summary of Magnetic Field Levels . . . . .	5-9
5.6 Summary of Electric Field Levels . . . . .	5-11
6. MEASUREMENTS IN PASSENGER STATIONS . . . . .	6-1
6.1 Measurement Locations . . . . .	6-1
6.2 Repetitive Waveform Datasets . . . . .	6-4
6.3 Magnetic Field Characteristics . . . . .	6-4



VOLUME I  
TABLE OF CONTENTS (CONT'D)

Section	Page
6.4 DAT Waveform Data . . . . .	6-13
6.5 RMS Recorder Data . . . . .	6-14
6.6 Summary of Magnetic Field Levels . . . . .	6-18
6.7 Summary of Electric Field Levels . . . . .	6-25
7. POWER SUPPLY SYSTEM MEASUREMENTS . . . . .	7-1
7.1 Measurement Locations . . . . .	7-1
7.2 Repetitive Waveform Datasets . . . . .	7-4
7.3 Magnetic Field Characteristics . . . . .	7-4
7.4 DAT Waveform Data . . . . .	7-9
7.5 RMS Recorder Data . . . . .	7-9
7.6 Summary of Magnetic Field Levels . . . . .	7-12
7.7 Summary of Electric Field Levels . . . . .	7-19
8. MEASUREMENTS IN CONTROL FACILITIES . . . . .	8-1
8.1 Measurement Locations . . . . .	8-1
8.2 Repetitive Waveform Datasets . . . . .	8-1
8.3 Magnetic Field Characteristics . . . . .	8-1
8.4 DAT Waveform Data . . . . .	8-8
8.5 RMS Recorder Data . . . . .	8-8
8.6 Summary of Magnetic Field Levels . . . . .	8-8
8.7 Summary of Electric Field Levels . . . . .	8-10
9. CONCLUSIONS . . . . .	9-1
9.1 Summary of Metrorail Field Levels . . . . .	9-2
9.1.1 Metrorail Cars . . . . .	9-2
9.1.2 Operator's Compartment . . . . .	9-3
9.1.3 Metrorail Waysides . . . . .	9-3
9.1.4 Passenger Station Platforms . . . . .	9-4
9.1.5 Traction Power Supply Stations . . . . .	9-4
9.1.6 Control Facilities . . . . .	9-5
9.2 Environmental Magnetic Field Levels . . . . .	9-5
9.3 Comparison of Metrorail Fields to Other Electro-Technologies . . . . .	9-9
9.3.1 Static Fields . . . . .	9-9
9.3.2 Frequency Spectrum . . . . .	9-11
9.3.3 Time Characteristics . . . . .	9-11
9.3.4 Amplitude Characteristics . . . . .	9-11
9.3.4.1 Cars . . . . .	9-11
9.3.4.2 Operator's Compartment . . . . .	9-14

VOLUME I  
TABLE OF CONTENTS (CONT'D)

Section	Page
9.3.4.3 Along the Wayside . . . . .	9-14
9.3.4.4 Passenger Stations . . . . .	9-14
9.3.4.5 Power Supply System Measurements . . . . .	9-14
9.3.4.6 Control Areas . . . . .	9-19
9.4 Comparison of Metrorail Fields to Existing Standards . . . . .	9-19
9.4.1 World Health Organization . . . . .	9-19
9.4.2 International Radiation Protection Association . . . . .	9-22
9.4.3 American Conference of Governmental Industrial Hygienists . . . . .	9-23
9.4.4 State Power Line Limits . . . . .	9-23
10. REFERENCES . . . . .	10-1

**VOLUME I  
LIST OF FIGURES**

<b>Figure</b>		<b>Page</b>
1-1	MAP OF A PORTION OF THE METRORAIL SYSTEM SHOWING THE LINES TRAVELED AND LOCATIONS OF MEASUREMENTS .....	1-3
1-2	THE RANGE OF TOTAL TIME VARYING MAGNETIC FIELD LEVELS IN THE METRORAIL CARS AT VARIOUS HEIGHTS ABOVE THE FLOOR COMPARED TO TYPICAL LEVELS OF POWER FREQUENCY MAGNETIC FIELDS PRODUCED BY COMMON SOURCES .....	1-9
1-3	THE RANGE OF TOTAL TIME VARYING MAGNETIC FIELD LEVELS IN THE CENTER OF THE 3000 SERIES METRORAIL CARS AT VARIOUS HEIGHTS ABOVE THE FLOOR COMPARED TO TYPICAL LEVELS OF POWER FREQUENCY MAGNETIC FIELDS PRODUCED BY COMMON SOURCES .....	1-10
1-4	THE RANGE OF TOTAL TIME VARYING MAGNETIC FIELD LEVELS IN THE OPERATOR'S COMPARTMENT OF THE METRORAIL CARS AT VARIOUS HEIGHTS ABOVE THE FLOOR COMPARED TO TYPICAL LEVELS OF POWER FREQUENCY MAGNETIC FIELDS PRODUCED BY COMMON SOURCES .....	1-12
1-5	THE RANGE OF TOTAL TIME VARYING MAGNETIC FIELD LEVELS AT A WAYSIDE AND A HIGHWAY UNDERPASS, AT VARIOUS DISTANCES FROM THE NEAREST TRACK, COMPARED TO TYPICAL LEVELS OF POWER FREQUENCY MAGNETIC FIELDS PRODUCED BY COMMON SOURCES .....	1-13
1-6	THE RANGE OF TOTAL TIME VARYING MAGNETIC FIELD LEVELS ON THE PLATFORMS, AT VARIOUS DISTANCES FROM THE PLATFORM EDGE, COMPARED TO TYPICAL LEVELS OF POWER FREQUENCY MAGNETIC FIELDS PRODUCED BY COMMON SOURCES .....	1-14
1-7	THE RANGE OF TOTAL TIME VARYING MAGNETIC FIELD LEVELS OUTSIDE TRACTION POWER SUPPLY STATIONS, AT VARIOUS DISTANCES FROM THE FENCE OR WALL, COMPARED TO TYPICAL LEVELS OF POWER FREQUENCY MAGNETIC FIELDS PRODUCED BY COMMON SOURCES .....	1-15
1-8	THE RANGE OF TOTAL TIME VARYING MAGNETIC FIELD LEVELS AT VARIOUS DISTANCES IN FRONT OF A DISPATCHER'S VIDEO DISPLAY TERMINAL COMPARED TO TYPICAL LEVELS OF POWER FREQUENCY MAGNETIC FIELDS PRODUCED BY COMMON SOURCES .....	1-16

VOLUME I  
LIST OF FIGURES (CONT'D)

Figure		Page
2-1	MAGNETIC FIELD FLUX DENSITIES GROUPED BY FREQUENCY PARTITIONS WITHIN THE ELF BAND AND ULF BAND .....	2-8
3-1	REPETITIVE WAVEFORM MEASUREMENT LOCATIONS WITHIN THE CARS AND OPERATOR'S COMPARTMENT .....	3-2
3-2	MAGNETIC FIELD 10 cm ABOVE THE FLOOR IN THE CENTER OF A 1000 SERIES CAR AS A FUNCTION OF FREQUENCY AND TIME. THE STATIC FIELD COMPONENT IS SUPPRESSED IN THE LOWER FRAME TO SHOW THE TIME VARYING COMPONENTS .....	3-6
3-3	MAGNETIC FIELD 160 cm ABOVE THE FLOOR IN THE CENTER OF A 1000 SERIES CAR AS A FUNCTION OF FREQUENCY AND TIME. THE STATIC FIELD COMPONENT IS SUPPRESSED IN THE LOWER FRAME TO SHOW THE TIME VARYING COMPONENTS .....	3-8
3-4	STATIC (TOP FRAME) AND LOW FREQUENCY TIME VARYING (BOTTOM FRAME) MAGNETIC FIELD IN THE CENTER OF A 1000 SERIES CAR AS A FUNCTION OF HEIGHT ABOVE THE FLOOR AND TIME .....	3-9
3-5	MAGNETIC FIELD 10 cm ABOVE THE FLOOR IN THE REAR OF A 1000 SERIES CAR AS A FUNCTION OF FREQUENCY AND TIME. THE STATIC FIELD COMPONENT IS SUPPRESSED IN THE LOWER FRAME TO SHOW THE TIME VARYING COMPONENTS .....	3-11
3-6	MAGNETIC FIELD 160 cm ABOVE THE FLOOR IN THE REAR OF A 1000 SERIES CAR AS A FUNCTION OF FREQUENCY AND TIME. THE STATIC FIELD COMPONENT IS SUPPRESSED IN THE LOWER FRAME TO SHOW THE TIME VARYING COMPONENTS .....	3-12
3-7	STATIC (TOP FRAME) AND LOW FREQUENCY TIME VARYING (BOTTOM FRAME) MAGNETIC FIELD IN THE REAR OF A 1000 SERIES CAR AS A FUNCTION OF HEIGHT ABOVE THE FLOOR AND TIME .....	3-13
3-8	GRAPHICAL COMPARISON OF STATIC MAGNETIC FIELD LEVELS 100 cm ABOVE THE FLOOR AT THE CENTER OF A 1000 SERIES CAR BASED ON STATISTICAL DESCRIPTORS .....	3-15

VOLUME I  
LIST OF FIGURES (CONT'D)

Figure		Page
3-9	TIME VARYING MAGNETIC FIELD 10 cm AND 160 cm ABOVE THE FLOOR AT THE CENTER OF A 2000 SERIES CAR AS A FUNCTION OF FREQUENCY AND TIME. THE TRAIN ACCELERATES AT 130 SECONDS .....	3-16
3-10	MAGNETIC FIELD 10 cm ABOVE THE FLOOR IN THE CENTER OF A 3000 SERIES CAR AS A FUNCTION OF FREQUENCY AND TIME. THE STATIC FIELD COMPONENT IS SUPPRESSED IN THE LOWER FRAME TO SHOW THE TIME VARYING COMPONENTS. DATA AT THE 6 SECOND DATA POINT ARE INVALID .....	3-18
3-11	MAGNETIC FIELD 160 cm ABOVE THE FLOOR IN THE CENTER OF A 3000 SERIES CAR AS A FUNCTION OF FREQUENCY AND TIME. THE STATIC FIELD COMPONENT IS SUPPRESSED IN THE LOWER FRAME TO SHOW THE TIME VARYING COMPONENTS .....	3-19
3-12	STATIC (TOP FRAME) TIME VARYING (BOTTOM FRAME) MAGNETIC FIELD IN THE CENTER OF A 3000 SERIES CAR AS A FUNCTION OF HEIGHT ABOVE THE FLOOR. DATA AT 10 AND 60 cm ABOVE THE FLOOR ARE INVALID AT THE 6 SECOND TIME POINT .....	3-20
3-13	TIME VARYING MAGNETIC FIELD 10 cm ABOVE THE FLOOR AT THE CENTER OF A 3000 SERIES CAR MEASURED WITH COIL-TYPE SENSORS .....	3-22
3-14	TIME DOMAIN PLOT OF THE CHANGING STATIC FIELD LEVEL IN A 1000 SERIES CAR SHOWING TIME-RATES-OF-CHANGE OF STATIC FIELD UP TO 4 GAUSS PER SECOND .....	3-25
3-15	TIME DOMAIN PLOT OF THE CHANGING STATIC FIELD LEVEL NEAR THE CENTER OF A 3000 SERIES CAR SHOWING AVERAGE RATES OF CHANGE, CHOPPER RIPPLE AND AN APPARENT TRANSIENT FIELD EPISODE .....	3-26
5-1	REPETITIVE WAVEFORM MEASUREMENT LOCATION AT HIGHWAY UNDERPASS AT ROCKVILLE .....	5-2
5-2	REPETITIVE WAVEFORM MEASUREMENT LOCATION AT WAYSIDE, SOUTH OF SHADY GROVE .....	5-3
5-3	MAGNETIC FIELD LEVEL, WITH AND WITHOUT THE STATIC COMPONENT, AT 110 cm HEIGHT ABOVE GROUND AT THE UNDERPASS AS A FUNCTION OF FREQUENCY AND TIME .....	5-5

VOLUME I  
LIST OF FIGURES (CONT'D)

Figure		Page
5-4	MAGNETIC FIELD LEVEL, WITH AND WITHOUT THE STATIC COMPONENT, AT 10 cm DISTANCE FROM THE FENCE AT THE WAYSIDE, SOUTH OF SHADY GROVE, AS A FUNCTION OF FREQUENCY AND TIME .....	5-8
5-5	ELECTRIC TIME VARYING FIELD LEVEL 1 m (3.3 ft) ABOVE GROUND, AT 6.1 m (20 ft) DISTANCE FROM THE FENCE AT THE WAYSIDE, SOUTH OF SHADY GROVE, AS A FUNCTION OF FREQUENCY AND TIME .....	5-13
6-1	REPETITIVE WAVEFORM MEASUREMENT LOCATIONS ON THE PASSENGER PLATFORM AT GROSVENOR .....	6-2
6-2	REPETITIVE WAVEFORM MEASUREMENT LOCATIONS AT THE GALLERY PASSENGER TRANSFER STATION PLATFORM AND MEZZANINE .....	6-3
6-3	MAGNETIC FIELD 10 cm ABOVE THE FLOOR AT THE EDGE OF THE GROSVENOR STATION PLATFORM AS A TRAIN ENTERS, STOPS, AND DEPARTS. THE STATIC FIELD IS SUPPRESSED IN THE LOWER FRAME TO SHOW THE TIME VARYING COMPONENTS .....	6-5
6-4	MAGNETIC FIELD 160 cm ABOVE THE FLOOR AT THE EDGE OF THE GROSVENOR STATION PLATFORM AS A TRAIN ENTERS, STOPS AND, DEPARTS. THE STATIC FIELD IS SUPPRESSED IN THE LOWER FRAME TO SHOW THE TIME VARYING COMPONENTS .....	6-6
6-5	CONTINUOUS MAGNETIC FIELD RECORDING AT THE EDGE OF THE GROSVENOR STATION PLATFORM AT THE ARRIVING END AS A TRAIN ENTERS, STOPS, AND DEPARTS .....	6-8
6-6	CONTINUOUS MAGNETIC FIELD RECORDING AT THE EDGE OF THE GROSVENOR STATION PLATFORM AT THE DEPARTING END AS A TRAIN ENTERS, STOPS, AND DEPARTS .....	6-11
6-7	CONTINUOUS MAGNETIC FIELD RECORDING AT THE EDGE OF THE GROSVENOR STATION PLATFORM MIDWAY ALONG THE PLATFORM AS A TRAIN ENTERS, STOPS, AND DEPARTS .....	6-12
6-8	MAGNETIC FIELD LEVEL RECORDED ON THE PASSENGER PLATFORM AT GROSVENOR USING THE RMS RECORDERS, AS A FUNCTION OF TIME .....	6-17

**VOLUME I  
LIST OF FIGURES (CONT'D)**

<b>Figure</b>		<b>Page</b>
7-1	REPETITIVE WAVEFORM MEASUREMENT LOCATIONS AT THE TRACTION POWER SUPPLY STATION SOUTH OF SHADY GROVE .....	7-2
7-2	REPETITIVE WAVEFORM MEASUREMENT LOCATIONS AT THE SHADY GROVE POWER SUPPLY STATION.....	7-3
7-3	MAGNETIC FIELD LEVEL, WITH AND WITHOUT THE STATIC COMPONENT, AT 110 cm DISTANCE FROM THE WALL AT THE SHADY GROVE TRACTION POWER SUPPLY STATION, AS A FUNCTION OF FREQUENCY AND TIME .....	7-5
7-4	MAGNETIC FIELD LEVEL VERSUS DISTANCE FROM STATION WALL AT 1 m (3.3 ft) HEIGHT, FOR THE POWER FREQUENCY (50-60 Hz) AND THE POWER FREQUENCY HARMONICS (65-300 Hz) COMPONENTS, AT THE TRACTION POWER SUPPLY STATION SOUTH OF SHADY GROVE, AS A FUNCTION OF TIME .....	7-6
7-5	MAGNETIC FIELD LEVEL, WITH AND WITHOUT THE STATIC COMPONENT, AT 110 cm DISTANCE FROM FENCE AND 1 m (3.3 ft) HEIGHT, AT THE SHADY GROVE TRACTION POWER SUPPLY STATION, AS A FUNCTION OF FREQUENCY AND TIME .....	7-8
7-6	MAGNETIC FIELD LEVELS RECORDED OUTSIDE THE TRACTION POWER SUPPLY STATION 4 km (2.5 mi) SOUTH OF SHADY GROVE USING THE RMS RECORDERS, AS A FUNCTION OF TIME .....	7-10
7-7	MAGNETIC FIELD LEVELS RECORDED OUTSIDE THE SHADY GROVE TRACTION POWER SUPPLY STATION USING THE RMS RECORDERS, AS A FUNCTION OF TIME.....	7-11
7-8	ELECTRIC TIME VARYING FIELD LEVEL 1 m (3.3 ft) ABOVE THE GROUND, 1.7 m (5.6 ft) FROM THE WEST WALL AT THE TRACTION POWER SUPPLY STATION SOUTH OF SHADY GROVE, AS A FUNCTION OF FREQUENCY AND TIME .....	7-19
8-1	REPETITIVE WAVEFORM MEASUREMENT LOCATIONS INSIDE THE DISPATCHER'S ROOM AT SHADY GROVE .....	8-2
8-2	MAGNETIC FIELD LEVEL, WITH AND WITHOUT THE STATIC COMPONENT, AT 10 cm HEIGHT ABOVE THE FLOOR BY THE DISPATCHER'S SEAT INSIDE THE DISPATCHER'S ROOM AT SHADY GROVE, AS A FUNCTION OF FREQUENCY AND TIME .....	8-4

VOLUME I  
LIST OF FIGURES (CONT'D)

Figure		Page
8-3	MAGNETIC FIELD LEVEL VERSUS HEIGHT ABOVE THE FLOOR FOR THE STATIC AND TIME VARYING (5-2560 Hz) COMPONENTS, AT THE DISPATCHER'S SEAT INSIDE THE DISPATCHER'S ROOM AT SHADY GROVE, AS A FUNCTION OF TIME .....	8-5
8-4	MAGNETIC FIELD LEVEL, WITH AND WITHOUT THE STATIC COMPONENT, AT 10 cm DISTANCE FROM THE DISPATCHER'S VIDEO DISPLAY MONITOR AND 1.25 m (4.1 ft) HEIGHT, INSIDE THE DISPATCHER'S ROOM AT SHADY GROVE, AS A FUNCTION OF FREQUENCY AND TIME .....	8-6
8-5	MAGNETIC FIELD LEVEL VERSUS DISTANCE FROM THE DISPATCHER'S VIDEO DISPLAY MONITOR AND 1.25 m (4.1 ft) HEIGHT FOR THE STATIC AND TIME VARYING (5-2560 Hz) COMPONENTS, INSIDE THE DISPATCHER'S ROOM AT SHADY GROVE, AS A FUNCTION OF TIME .....	8-7
8-6	MAGNETIC FIELD LEVELS RECORDED INSIDE THE SHADY GROVE DISPATCHER'S ROOM USING THE RMS RECORDERS, AS A FUNCTION OF TIME .....	8-9
8-7	ELECTRIC TIME VARYING FIELD LEVEL 1.8 m (5.9 ft) ABOVE THE FLOOR, AT THE DISPATCHER'S SEAT AT SHADY GROVE, AS A FUNCTION OF FREQUENCY AND TIME .....	8-12
9-1	ILLUSTRATION OF HOW THE MAGNETIC FIELD INTENSITY AT GROUND LEVEL CHANGES WITH HORIZONTAL DISTANCE FROM THREE COMMON SOURCES OF POWER-FREQUENCY MAGNETIC FIELDS. THE BANDS REPRESENT VARIATION ACROSS INDIVIDUAL SOURCES IN EACH GROUP. ADAPTED FROM NAIR, ET AL .....	9-7
9-2	MAGNETIC FIELD 30 cm FROM A SHOP VAC .....	9-8
9-3	ILLUSTRATION OF HOW ELECTRIC FIELD INTENSITY NEAR GROUND LEVEL WILL CHANGE WITH HORIZONTAL DISTANCE FROM THREE COMMON SOURCES OF POWER-FREQUENCY ELECTRIC FIELDS. THE BANDS REPRESENT VARIATION ACROSS INDIVIDUAL SOURCES IN EACH GROUP. ADAPTED FROM NAIR, ET AL .....	9-10
9-4	THE RANGE OF TOTAL TIME VARYING MAGNETIC FIELD LEVELS IN THE METRORAIL CARS AT VARIOUS HEIGHTS ABOVE THE FLOOR COMPARED TO TYPICAL LEVELS OF POWER FREQUENCY MAGNETIC FIELDS PRODUCED BY COMMON SOURCES .....	9-12



VOLUME I  
LIST OF FIGURES (CONT'D)

Figure		Page
9-5	THE RANGE OF TOTAL TIME VARYING MAGNETIC FIELD LEVELS IN THE CENTER OF THE 3000 SERIES METRORAIL CARS AT VARIOUS HEIGHTS ABOVE THE FLOOR COMPARED TO TYPICAL LEVELS OF POWER FREQUENCY MAGNETIC FIELDS PRODUCED BY COMMON SOURCES .....	9-13
9-6	THE RANGE OF TOTAL TIME VARYING MAGNETIC FIELD LEVELS IN THE OPERATOR'S COMPARTMENT OF THE METRORAIL CARS AT VARIOUS HEIGHTS ABOVE THE FLOOR COMPARED TO TYPICAL LEVELS OF POWER FREQUENCY MAGNETIC FIELDS PRODUCED BY COMMON SOURCES .....	9-15
9-7	THE RANGE OF TOTAL TIME VARYING MAGNETIC FIELD LEVELS AT A WAYSIDE AND A HIGHWAY UNDERPASS, AT VARIOUS DISTANCES FROM THE NEAREST TRACK, COMPARED TO TYPICAL LEVELS OF POWER FREQUENCY MAGNETIC FIELDS PRODUCED BY COMMON SOURCES .....	9-16
9-8	THE RANGE OF TOTAL TIME VARYING MAGNETIC FIELD LEVELS ON THE PLATFORMS, AT VARIOUS DISTANCES FROM THE PLATFORM EDGE, COMPARED TO TYPICAL LEVELS OF POWER FREQUENCY MAGNETIC FIELDS PRODUCED BY COMMON SOURCES .....	9-17
9-9	THE RANGE OF TOTAL TIME VARYING MAGNETIC FIELD LEVELS OUTSIDE TRACTION POWER SUPPLY STATIONS, AT VARIOUS DISTANCES FROM THE FENCE OR WALL, COMPARED TO TYPICAL LEVELS OF POWER FREQUENCY MAGNETIC FIELDS PRODUCED BY COMMON SOURCES .....	9-18
9-10	THE RANGE OF TOTAL TIME VARYING MAGNETIC FIELD LEVELS IN FRONT OF A DISPATCHER'S VIDEO DISPLAY TERMINAL COMPARED TO TYPICAL LEVELS OF POWER FREQUENCY MAGNETIC FIELDS PRODUCED BY COMMON SOURCES .....	9-20
9-11	COMPARISON OF MAXIMUM AND AVERAGE MAGNETIC FIELD LEVELS MEASURED 60 cm ABOVE THE FLOOR IN THE CENTER OF A METRORAIL 3000 SERIES CAR TO EXISTING STANDARDS .....	9-21

**VOLUME I  
LIST OF TABLES**

<b>Table</b>		<b>Page</b>
2-1	INDEX OF REPETITIVE WAVEFORM DATA WMATA METRORAIL MAY 19 - MAY 20, 1992 .....	2-11
2-2	INDEX OF CONTINUOUS WAVEFORM (DAT) DATA WMATA METRORAIL MEASUREMENTS MAY 19 & 20, 1992 .....	2-20
3-1	REPETITIVE MAGNETIC FIELD WAVEFORM DATASETS MEASURED ONBOARD METRORAIL CARS CLASSIFIED BY TYPE AND STAFF LOCATION .....	3-4
3-2	SUMMARY OF STATIC MAGNETIC FIELD LEVELS RECORDED IN A PASSENGER SEAT OF A METRORAIL CAR RECORDED WITH THE DIGITAL AUDIO TAPE RECORDER (DAT) .....	3-24
3-3	STATISTICAL SUMMARY OF MAGNETIC FIELD LEVELS RECORDED IN 3000 SERIES CARS USING RMS RECORDERS .....	3-28
3-4	SUMMARY STATISTICS FOR MAGNETIC FIELD LEVELS MEASURED IN THE CENTER OF A 1000 SERIES CAR .....	3-30
3-5	SUMMARY STATISTICS FOR MAGNETIC FIELD LEVELS MEASURED IN THE REAR OF A 1000 SERIES CAR .....	3-31
3-6	SUMMARY STATISTICS FOR MAGNETIC FIELD LEVELS MEASURED IN THE CENTER OF A 2000 SERIES CAR .....	3-32
3-7	SUMMARY STATISTICS FOR MAGNETIC FIELD LEVELS MEASURED IN THE REAR OF A 2000 SERIES CAR .....	3-33
3-8	SUMMARY STATISTICS FOR MAGNETIC FIELD LEVELS IN THE REAR OF A 3000 SERIES CAR .....	3-34
3-9	SUMMARY STATISTICS FOR MAGNETIC FIELD LEVELS IN THE CENTER AND REAR OF ALL CARS EXCEPT CENTER OF THE 3000 SERIES CAR .....	3-35
3-10	SUMMARY STATISTICS FOR STATIC MAGNETIC FIELD LEVELS MEASURED IN THE CENTER OF A 3000 SERIES CAR (CORRECTED FOR SENSOR SATURATION AS DISCUSSED IN TEXT) .....	3-36
3-11	SUMMARY STATISTICS FOR TIME VARYING MAGNETIC FIELD LEVELS MEASURED IN THE CENTER OF A 3000 SERIES CAR .....	3-37

VOLUME I  
LIST OF TABLES (CONT'D)

Table		Page
4-1	SUMMARY OF STATIC MAGNETIC FIELD LEVELS RECORDED IN THE OPERATOR'S SEAT OF A METRORAIL CAR RECORDED WITH THE DIGITAL AUDIO TAPE RECORDER (DAT) .....	4-3
4-2	SUMMARY STATISTICS FOR MAGNETIC FIELD LEVELS MEASURED IN THE OPERATOR'S COMPARTMENT OF A 1000 SERIES CAR .....	4-4
4-3	SUMMARY STATISTICS FOR MAGNETIC FIELD LEVELS MEASURED IN THE OPERATOR'S COMPARTMENT OF A 2000 SERIES CAR .....	4-5
4-4	SUMMARY STATISTICS FOR MAGNETIC FIELD LEVELS MEASURED IN THE OPERATOR'S COMPARTMENT OF A 3000 SERIES CAR .....	4-6
4-5	SUMMARY STATISTICS FOR MAGNETIC FIELD LEVELS MEASURED IN THE OPERATOR'S COMPARTMENT OF ALL TYPES OF CARS .....	4-7
5-1	REPETITIVE MAGNETIC FIELD WAVEFORM DATASETS MEASURED ALONG THE WAYSIDE .....	5-4
5-2	STATISTICAL SUMMARY OF THE MAGNETIC FIELD LEVEL AT VARIOUS HEIGHTS ABOVE THE ROAD SURFACE BENEATH THE METRORAIL AT THE HIGHWAY UNDERPASS AT ROCKVILLE (DATASETS MET054 AND MET055) .....	5-10
5-3	STATISTICAL SUMMARY OF THE MAGNETIC FIELD LEVEL AT VARIOUS DISTANCES FROM THE TRAIN TRACK FENCE, ALONG THE WAYSIDE SOUTH OF SHADY GROVE (DATASET MET056) .....	5-12
6-1	SUMMARY OF STATIC MAGNETIC FIELD LEVELS RECORDED AT THE EDGE OF STATION PLATFORMS WITH THE DIGITAL AUDIO TAPE RECORDER (DAT) AS TRAINS PASS .....	6-15
6-2	SUMMARY OF STATIC MAGNETIC FIELD LEVELS RECORDED ON A STATION MEZZANINE WITH THE DIGITAL AUDIO TAPE RECORDER (DAT) AS TRAINS PASS BELOW .....	6-16
6-3	SUMMARY OF MAGNETIC FIELD LEVELS RECORDED ON THE GROSVENOR PASSENGER PLATFORM USING RMS DATA RECORDERS .....	6-16

VOLUME I  
LIST OF TABLES (CONT'D)

Table		Page
6-4	STATISTICAL SUMMARY OF THE MAGNETIC FIELD LEVEL OF COMBINED VERTICAL DATASETS AT THE SAFETY LINE AT THE GROSVENOR PASSENGER STATION PLATFORM (DATASETS MET015, 017, 022 AND MET024) .....	6-19
6-5	STATISTICAL SUMMARY OF THE MAGNETIC FIELD LEVEL AT VARIOUS HEIGHTS ABOVE THE FLOOR AT THE BOTTOM OF ESCALATOR AT THE GROSVENOR PASSENGER STATION PLATFORM (DATASET MET019) .....	6-21
6-6	STATISTICAL SUMMARY OF THE MAGNETIC FIELD LEVEL AT VARIOUS HEIGHTS ABOVE THE MOVING STEPS WHILE RIDING UP AND DOWN ON THE ESCALATOR AT THE GROSVENOR PASSENGER STATION PLATFORM (DATASET MET021) .....	6-22
6-7	STATISTICAL SUMMARY OF THE MAGNETIC FIELD LEVEL OF COMBINED VERTICAL DATASETS AT THE SAFETY LINE OF THE LOWER PLATFORM AT THE GALLERY PASSENGER TRANSFER STATION (DATASETS MET031 AND MET033) ...	6-23
6-8	STATISTICAL SUMMARY OF THE MAGNETIC FIELD LEVEL OF COMBINED VERTICAL DATASETS AT THE MEZZANINE OF THE GALLERY PASSENGER TRANSFER STATION (DATASETS MET035 AND MET037) .....	6-24
7-1	STATISTICAL SUMMARY OF MAGNETIC FIELDS IN mG RECORDED AT TRACTION POWER SUPPLY STATIONS USING RMS DATA RECORDERS .....	7-12
7-2	STATISTICAL SUMMARY OF THE MAGNETIC FIELD LEVEL AT VARIOUS DISTANCES FROM THE NORTH WALL, OUTSIDE THE TRACTION POWER SUPPLY STATION 4 km (2.5 mi) SOUTH OF SHADY GROVE (DATASET MET038) .....	7-13
7-3	STATISTICAL SUMMARY OF THE MAGNETIC FIELD LEVEL AT VARIOUS DISTANCES FROM THE WALLS, OF COMBINED DATASETS OUTSIDE THE TRACTION POWER SUPPLY STATION OF SHADY GROVE (DATASETS MET038 THROUGH MET042) .....	7-14
7-4	STATISTICAL SUMMARY OF THE MAGNETIC FIELD LEVEL AT VARIOUS DISTANCES FROM THE SOUTH FENCE, OUTSIDE THE SHADY GROVE TRACTION POWER SUPPLY STATION (DATASET MET043) .....	7-15

VOLUME I  
LIST OF TABLES (CONT'D)

Table		Page
7-5	STATISTICAL SUMMARY OF THE MAGNETIC FIELD LEVEL AT VARIOUS DISTANCES FROM THE SOUTH WALL, OUTSIDE THE SHADY GROVE TRACTION POWER SUPPLY STATION (DATASET MET044) .....	7-16
7-6	STATISTICAL SUMMARY OF THE MAGNETIC FIELD LEVEL AT VARIOUS DISTANCES FROM THE WEST WALL, OUTSIDE THE SHADY GROVE TRACTION POWER SUPPLY STATION (DATASET MET045) .....	7-17
8-1	STATISTICAL SUMMARY OF MAGNETIC FIELDS IN mG RECORDED INSIDE THE DISPATCHER'S ROOM USING RMS DATA RECORDERS .....	8-8
8-2	STATISTICAL SUMMARY OF THE MAGNETIC FIELD LEVEL AT VARIOUS HEIGHTS ABOVE THE FLOOR INSIDE THE DISPATCHER'S ROOM AT SHADY GROVE (DATASET MET046) .....	8-11

**VOLUME II  
TABLE OF CONTENTS**

<b>Section</b>	<b>Page</b>
APPENDIX A DESCRIPTION OF APPENDED DATA .....	A-1
APPENDIX B DATASET MET001 - CENTER OF AISLE, CENTER OF CAR #1173 .....	B-1
APPENDIX C DATASET MET002 - CENTER OF AISLE, REAR OF CAR #1173 .....	C-1
APPENDIX D DATASET MET003 - IN FRONT OF OPERATOR'S SEAT, CAR #1173 .....	D-1
APPENDIX E DATASET MET004 - CENTER OF AISLE, CENTER OF CAR #3012 .....	E-1
APPENDIX F DATASET MET006 - CENTER OF AISLE, CENTER OF CAR #3012 .....	F-1
APPENDIX G DATASET MET007 - CENTER OF AISLE, CENTER OF CAR #3012 .....	G-1
APPENDIX H DATASET MET008 - CENTER OF AISLE, REAR OF CAR #3012 .....	H-1
APPENDIX I DATASET MET009 - IN FRONT OF OPERATOR'S SEAT, CAR #3012 .....	I-1
APPENDIX J DATASET MET010 - AXIAL PROFILE AT REAR OF CAR #3012 .....	J-1
APPENDIX K DATASET MET011 - TRANSVERSE PROFILE AT REAR OF CAR #3012 .....	K-1
APPENDIX L DATASET MET012 - TRANSVERSE PROFILE IN CENTER OF CAR #3090 .....	L-1
APPENDIX M DATASET MET013 - AXIAL PROFILE IN CENTER OF CAR #3090 .....	M-1
APPENDIX N DATASET MET014 - NEAR LEFT CENTER DOOR OF CAR #3090 .....	N-1
APPENDIX O DATASET MET015 - GROSVENOR STATION, NORTH BOUND SIDE OF PLATFORM .....	O-1
APPENDIX P DATASET MET017 - GROSVENOR STATION, SOUTH BOUND SIDE OF PLATFORM .....	P-1

**VOLUME II  
TABLE OF CONTENTS (CONT'D)**

<b>Section</b>	<b>Page</b>
APPENDIX Q DATASET MET018 - GROSVENOR STATION, SOUTH BOUND SIDE OF PLATFORM .....	Q-1
APPENDIX R DATASET MET019 - GROSVENOR STATION, BOTTOM OF ESCALATOR .....	R-1
APPENDIX S DATASET MET021 - GROSVENOR STATION, ON THE ESCALATOR .....	S-1
APPENDIX T DATASET MET022 - GROSVENOR STATION, NORTH BOUND SIDE OF PLATFORM .....	T-1
APPENDIX U DATASET MET024 - GROSVENOR STATION, NORTH BOUND SIDE OF PLATFORM .....	U-1
APPENDIX V DATASET MET025 - GROSVENOR STATION, NORTH BOUND SIDE OF PLATFORM .....	V-1
APPENDIX W DATASET MET026 - IN FRONT OF OPERATOR'S SEAT IN A 2000 SERIES CAR .....	W-1
APPENDIX X DATASET MET027 - CENTER OF AISLE, REAR OF A 2000 SERIES CAR .....	X-1
APPENDIX Y DATASET MET028 - CENTER OF AISLE, CENTER OF A 2000 SERIES CAR .....	Y-1
APPENDIX Z DATASET MET029 - AXIAL PROFILE IN CENTER OF A 2000 SERIES CAR .....	Z-1
APPENDIX AA DATASET MET030 - TRANSVERSE PROFILE IN CENTER OF A 2000 SERIES CAR .....	AA-1
APPENDIX AB DATASET MET031 - GALLERY PLACE PLATFORM, SOUTH BOUND SIDE .....	AB-1
APPENDIX AC DATASET MET032 - GALLERY PLACE PLATFORM, SOUTH BOUND SIDE .....	AC-1
APPENDIX AD DATASET MET033 - GALLERY PLACE PLATFORM, NORTH BOUND SIDE .....	AD-1
APPENDIX AE DATASET MET034 - GALLERY PLACE PLATFORM, NORTH BOUND SIDE .....	AE-1
APPENDIX AF DATASET MET035 - ON MEZZANINE AT GALLERY PLACE STATION .....	AF-1

**VOLUME II  
TABLE OF CONTENTS (CONT'D)**

<b>Section</b>	<b>Page</b>
APPENDIX AG DATASET MET037 - ON MEZZANINE AT GALLERY PLACE STATION .....	AG-1
APPENDIX AH DATASET MET038 - AT TRACTION POWER SUPPLY STATION SOUTH OF SHADY GROVE .....	AH-1
APPENDIX AI DATASET MET039 - AT TRACTION POWER SUPPLY STATION SOUTH OF SHADY GROVE .....	AI-1
APPENDIX AJ DATASET MET040 - AT TRACTION POWER SUPPLY STATION SOUTH OF SHADY GROVE .....	AJ-1
APPENDIX AK DATASET MET041 - AT TRACTION POWER SUPPLY STATION SOUTH OF SHADY GROVE .....	AK-1
APPENDIX AL DATASET MET042 - AT TRACTION POWER SUPPLY STATION SOUTH OF SHADY GROVE .....	AL-1
APPENDIX AM DATASET MET043 - AT SHADY GROVE TRACTION POWER SUPPLY STATION .....	AM-1
APPENDIX AN DATASET MET044 - AT SHADY GROVE TRACTION POWER SUPPLY STATION .....	AN-1
APPENDIX AO DATASET MET045 - AT SHADY GROVE TRACTION POWER SUPPLY STATION .....	AO-1
APPENDIX AP DATASET MET046 - SHADY GROVE DISPATCHER'S ROOM, AT DISPATCHER'S CHAIR .....	AP-1
APPENDIX AQ DATASET MET047 - SHADY GROVE DISPATCHER'S ROOM, FROM MONITORS .....	AQ-1
APPENDIX AR DATASET MET048 - SHADY GROVE DISPATCHER'S ROOM, FROM MOCK-UP PANEL .....	AR-1
APPENDIX AS DATASET MET049 - CENTER OF AISLE, CENTER OF A 3000 SERIES CAR .....	AS-1
APPENDIX AT DATASET MET050 - AXIAL PROFILE IN CENTER OF A 3000 SERIES CAR, FLOOR LEVEL .....	AT-1
APPENDIX AU DATASET MET051 - TRANSVERSE PROFILE IN CENTER OF A 3000 SERIES CAR, FLOOR LEVEL ...	AU-1
APPENDIX AV DATASET MET052 - TRANSVERSE PROFILE IN CENTER OF A 3000 SERIES CAR, 1 m (3.3 ft) ABOVE FLOOR .....	AV-1



VOLUME II  
TABLE OF CONTENTS (CONT'D)

Section	Page
APPENDIX AW DATASET MET053 - AXIAL PROFILE IN CENTER OF A 3000 SERIES CAR, 1 m (3.3 ft) ABOVE FLOOR .....	AW-1
APPENDIX AX DATASET MET054 - BENEATH METRORAIL AT HIGHWAY UNDERPASS .....	AX-1
APPENDIX AY DATASET MET055 - BENEATH METRORAIL AT HIGHWAY UNDERPASS .....	AY-1
APPENDIX AZ DATASET MET056 - ALONG WAYSIDE SOUTH OF SHADY GROVE .....	AZ-1

**VOLUME II  
LIST OF FIGURES**

<b>Figure</b>		<b>Page</b>
A-1	CAR LAYOUT .....	A-10
A-2	HIGHWAY UNDERPASS AT ROCKVILLE .....	A-11
A-3	AT WAYSIDE, SOUTH OF SHADY GROVE .....	A-12
A-4	PLATFORM AT GROSVENOR .....	A-13
A-5	GALLERY PLACE PLATFORM AND MEZZANINE .....	A-14
A-6	TRACTION POWER SUPPLY STATION SOUTH OF SHADY GROVE .....	A-15
A-7	SHADY GROVE TRACTION POWER SUPPLY STATION .....	A-16
A-8	DISPATCHER'S ROOM AT SHADY GROVE .....	A-17

**VOLUME II  
LIST OF TABLES**

<b>Table</b>		<b>Page</b>
A-1	INDEX OF REPETITIVE WAVEFORM DATA WMATA METRORAIL MAY 19 - MAY 20, 1992 .....	A-2

## APPENDIX A

### DESCRIPTION OF APPENDED DATA

The following 51 appendices contain a detailed reporting of the magnetic field characteristics measured onboard the WMATA Metrorail and near associated facilities. The data have been consolidated and presented as efficiently as possible without resorting to summary measures which obscure the temporal or frequency characteristics of the magnetic fields. The analysis of summary data obtained by collapsing the frequency spectra into a small number of relatively broad bands or by collapsing the time distributions into statistical parameters is found in the body of the report.

One appendix is provided for each of the 51 repetitive waveform datasets collected during the May 19 and 20, 1992 measurement program. Table A-1 provides a list of the datasets and the relevant parameters, and the appendix where each dataset may be found. Appendices may contain the following material:

- Table of measurement parameters
- Field by frequency and time plots for each field sensor
- Field by distance and time plot for six frequency bands
- Summary statistics

Each of these items is described below.

#### Table of Measurement Parameters

Each appendix begins with a table of measurement parameters. It identifies the dataset by number and title and gives measurement setup code which refers to the sensor staff and reference probe locations on the appropriate sketch of the measurement setup. (Copies of the setup sketches are included in this appendix as Figures A-1 through A-8.) The vehicle status entry indicates whether the trains were operating during the test and includes general comments on the mode of operation.

The next group of data on the table of measurement parameters identifies the time during which repetitive waveform measurements were made. Start and stop time are merely clock times for the first and last waveform samples, respectively. During that time period, the indicated number of waveform samples were taken. The programmed sample interval and actual sample interval represent the requested and actual time between successive waveform samples. These should agree. However, during the tests, the test engineers wanted the waveform capture system to sample as frequently as possible. In this mode, samples are sometimes delayed if the system is automatically adjusting its programmable amplifiers in response to a sudden change in field intensity.

TABLE A-1.

INDEX OF REPETITIVE WAVEFORM DATA WMATA METRORAIL  
 May 19 - May 20, 1992

DATA FILE NUMBER	APPENDIX CONTAINING DATA	DATE/TIME	PROBE LOCATION FIG. STAFF REF.	SAMPLE INTERVAL, SECONDS	NUMBER OF SAMPLES	LOCATION AND TYPE OF MEASUREMENT
		MAY 19				
MET001	B	08:25-08:29	3-1 1	5	18	CENTER OF AISLE IN CENTER OF CAR #1173 ON RED LINE. STAFF IN VERTICAL POSITION.
MET002	C	08:32-08:35	3-1 5	5	14	CENTER OF AISLE AT REAR OF CAR #1173 ON RED LINE. STAFF IN VERTICAL POSITION.
MET003	D	08:36-08:40	3-1 8	5	27	IN FRONT OF OPERATOR'S SEAT AT REAR OF CAR #1173 ON RED LINE. STAFF IN VERTICAL POSITION.
MET004	E	10:00-10:00	3-1 1	5	2	CENTER OF AISLE IN CENTER OF CAR #3012 ON RED LINE. STAFF IN VERTICAL POSITION.
MET006	F	10:04-10:05	3-1 1	5	10	SAME POSITION AS MET004.
MET007	G	10:07-10:09	3-1 1	5	12	SAME POSITION AS MET004.
MET008	H	10:12-10:15	3-1 5	5	16	CENTER OF AISLE AT REAR OF CAR #3012 ON RED LINE. STAFF IN VERTICAL POSITION.

**TABLE A-1.**  
**INDEX OF REPETITIVE WAVEFORM DATA WMATA METRO RAIL**  
**May 19 - May 20, 1992 (CONT'D)**

DATA FILE NUMBER	APPENDIX CONTAINING DATA	DATE/TIME	PROBE LOCATION FIG. STAFF REF.	SAMPLE INTERVAL, SECONDS	NUMBER OF SAMPLES	LOCATION AND TYPE OF MEASUREMENT
MET009	I	10:16-10:18	3-1 8 11	5	10	IN FRONT OF OPERATOR'S SEAT AT REAR OF CAR #3012 ON RED LINE. STAFF IN VERTICAL POSITION.
MET010	J	10:18-10:20	3-1 6 10	5	13	REAR OF CAR #3012 ON RED LINE. STAFF IN HORIZONTAL POSITION ALONG THE AXIS OF THE CAR WITH THE REAR DOOR AS THE REFERENCE.
MET011	K	10:21-10:22	3-1 7 10	5	10	REAR OF CAR #3012 ON RED LINE. STAFF IN HORIZONTAL POSITION TRANSVERSE TO THE AXIS OF THE CAR WITH CENTER OF AISLE AS THE REFERENCE.
MET012	L	10:34-10:35	3-1 3 -	5	9	CENTER OF CAR #3090 ON RED LINE. STAFF IN HORIZONTAL POSITION TRANSVERSE TO THE AXIS OF THE CAR WITH CENTER OF AISLE AS THE REFERENCE.
MET013	M	10:35-10:38	3-1 2 -	5	18	CENTER OF CAR #3090 ON RED LINE. STAFF IN HORIZONTAL POSITION ALONG THE AXIS OF THE CAR WITH THE CENTER OF THE CAR AS THE REFERENCE.
MET014	N	10:39-10:40	3-1 4 -	5	6	NEAR DOORS AT LEFT CENTER OF CAR #3090 ON RED LINE. STAFF IN VERTICAL POSITION.

**TABLE A-1.**  
**INDEX OF REPETITIVE WAVEFORM DATA WMATA METRO RAIL**  
**May 19 - May 20, 1992 (CONT'D)**

DATA FILE NUMBER	APPENDIX CONTAINING DATA	DATE/TIME	PROBE LOCATION FIG. STAFF REF.	SAMPLE INTERVAL, SECONDS	NUMBER OF SAMPLES	LOCATION AND TYPE OF MEASUREMENT
MET015	O	10:56-10:57	6-1 16 17	5	11	ON DEPARTING END OF NORTH BOUND SIDE OF GROSVENOR STATION PLATFORM AT SAFETY LINE. STAFF IN VERTICAL POSITION.
MET017	P	11:00-11:02	6-1 18 19	5	23	ON ARRIVING END OF SOUTH BOUND SIDE OF GROSVENOR STATION PLATFORM AT SAFETY LINE. STAFF IN VERTICAL POSITION.
MET018	Q	11:05-11:08	6-1 20 17	5	34	ON ARRIVING END OF GROSVENOR STATION PLATFORM AT SAFETY LINE. STAFF IN HORIZONTAL POSITION 1 m (3.3 ft) ABOVE PLATFORM WITH SAFETY LINE AS REFERENCE.
MET019	R	11:10-11:11	6-1 21 -	5	6	AT GROSVENOR STATION, BOTTOM OF ESCALATOR. STAFF IN VERTICAL POSITION.
MET021	S	11:16-11:17	6-1 22, 23 -	5	13	AT GROSVENOR STATION, UP AND DOWN THE ESCALATOR. STAFF IN VERTICAL POSITION WITH ESCALATOR STEP AS REFERENCE.
MET022	T	11:20-11:21	6-1 24 25	5	11	CENTER OF GROSVENOR STATION PLATFORM AT SAFETY LINE. STAFF IN VERTICAL POSITION.
MET024	U	11:24-11:25	6-1 24 25	5	10	SAME AS MET022.

TABLE A-1.

INDEX OF REPETITIVE WAVEFORM DATA WMATA METRORAIL  
 May 19 - May 20, 1992 (CONT'D)

DATA FILE NUMBER	APPENDIX CONTAINING DATA	DATE/TIME	PROBE LOCATION FIG. STAFF REF.	SAMPLE INTERVAL, SECONDS	NUMBER OF SAMPLES	LOCATION AND TYPE OF MEASUREMENT
MET025	V	11:27-11:31	6-1 26 27	5	41	CENTER OF GROSVENOR STATION PLATFORM. STAFF IN HORIZONTAL POSITION WITH SAFETY LINE AS REFERENCE.
MET026	W	15:31-15:33	3-1 8 -	5	9	IN FRONT OF OPERATOR'S SEAT AT REAR OF A 2000 SERIES CAR ON GREEN LINE. STAFF IN VERTICAL POSITION.
MET027	X	15:34-15:35	3-1 5 -	5	11	CENTER OF AISLE AT REAR OF A 2000 SERIES CAR ON GREEN LINE. STAFF IN VERTICAL POSITION.
MET028	Y	15:38-15:41	3-1 1 -	5	24	CENTER OF AISLE IN CENTER OF A 2000 SERIES CAR ON GREEN LINE. STAFF IN VERTICAL POSITION.
MET029	Z	15:41-15:42	3-1 2 -	5	7	CENTER OF A 2000 SERIES CAR ON GREEN LINE. STAFF IN HORIZONTAL POSITION ALONG THE AXIS OF THE CAR WITH THE CENTER OF THE CAR AS THE REFERENCE.
MET030	AA	15:43-15:43	3-1 3 -	5	4	CENTER OF A 2000 SERIES CAR ON GREEN LINE. STAFF IN HORIZONTAL POSITION TRANSVERSE TO AXIS OF THE CAR WITH CENTER OF AISLE AS THE REFERENCE.
MET031	AB	15:49-15:51	6-2 28 -	5	26	ON SOUTH BOUND SIDE OF GALLERY PLACE GREEN/YELLOW LINE PLATFORM. STAFF IN VERTICAL POSITION AT PLATFORM EDGE.

TABLE A-1.

INDEX OF REPETITIVE WAVEFORM DATA WMATA METRO RAIL  
 May 19 - May 20, 1992 (CONT'D)

DATA FILE NUMBER	APPENDIX CONTAINING DATA	DATE/TIME	PROBE LOCATION FIG. STAFF REF.	SAMPLE INTERVAL, SECONDS	NUMBER OF SAMPLES	LOCATION AND TYPE OF MEASUREMENT
MET032	AC	15:52-15:53	6-2 30	5	15	ON SOUTH BOUND SIDE OF GALLERY PLACE GREEN/YELLOW LINE PLATFORM. STAFF IN HORIZONTAL POSITION WITH EDGE OF PLATFORM AS THE REFERENCE.
MET033	AD	15:56-15:58	6-2 31	5	11	ON NORTH BOUND SIDE OF GALLERY PLACE GREEN/YELLOW LINE PLATFORM. STAFF IN VERTICAL POSITION AT PLATFORM EDGE.
MET034	AE	15:59-16:01	6-2 33	5	16	ON NORTH BOUND SIDE OF GALLERY PLACE GREEN/YELLOW LINE PLATFORM. STAFF IN HORIZONTAL POSITION WITH EDGE OF PLATFORM AS THE REFERENCE.
MET035	AF	16:05-16:05	6-2 34	5	4	ON MEZZANINE AT GALLERY PLACE STATION. STAFF IN VERTICAL POSITION DIRECTLY OVER CENTER GREEN/YELLOW LINE TRACK.
MET037	AG	16:11-16:13	6-2 35	5	18	SAME AS MET035.
MET038	AH	08:39-08:42	7-1 36	5	38	TRACTION POWER SUPPLY STATION SOUTH OF SHADY GROVE. STAFF IN HORIZONTAL POSITION 1 m (3.3 ft) ABOVE GROUND WITH NORTH WALL AS THE REFERENCE.



TABLE A-1.

INDEX OF REPETITIVE WAVEFORM DATA WMATA METRORAIL  
 May 19 - May 20, 1992 (CONT'D)

DATA FILE NUMBER	APPENDIX CONTAINING DATA	DATE/TIME	PROBE LOCATION FIG. STAFF REF.	SAMPLE INTERVAL, SECONDS	NUMBER OF SAMPLES	LOCATION AND TYPE OF MEASUREMENT
MET039	AI	08:44-08:48	7-1 38	5	38	TRACTION POWER SUPPLY STATION SOUTH OF SHADY GROVE. STAFF IN HORIZONTAL POSITION 1 m (3.3 ft) ABOVE GROUND WITH WEST WALL AS THE REFERENCE.
MET040	AJ	08:50-08:56	7-1 40	5	62	SAME AS MET039.
MET041	AK	08:59-09:02	7-1 42	5	39	SAME AS MET039.
MET042	AL	09:05-09:09	7-1 44	5	37	TRACTION POWER SUPPLY STATION SOUTH OF SHADY GROVE. STAFF IN HORIZONTAL POSITION 1 m (3.3 ft) ABOVE GROUND WITH SOUTH WALL AS THE REFERENCE.
MET043	AM	09:42-09:45	7-2 46	5	38	SHADY GROVE TRACTION POWER SUPPLY STATION. STAFF IN HORIZONTAL POSITION WITH SOUTH EDGE OF FENCE AS THE REFERENCE.
MET044	AN	09:53-09:57	7-2 48	5	38	SHADY GROVE TRACTION POWER SUPPLY STATION. STAFF IN HORIZONTAL POSITION WITH SOUTH WALL OF BRICK BUILDING AS THE REFERENCE.
MET045	AO	10:01-10:05	7-2 50	5	43	SHADY GROVE TRACTION POWER SUPPLY STATION. STAFF IN HORIZONTAL POSITION WITH WEST WALL OF BRICK BUILDING AS THE REFERENCE.

**TABLE A-1.**  
**INDEX OF REPETITIVE WAVEFORM DATA WMATA METRORAIL**  
**May 19 - May 20, 1992 (CONT'D)**

DATA FILE NUMBER	APPENDIX CONTAINING DATA	DATE/TIME	PROBE LOCATION FIG. STAFF REF.	SAMPLE INTERVAL, SECONDS	NUMBER OF SAMPLES	LOCATION AND TYPE OF MEASUREMENT
MET046	AP	11:11-11:12	8-1 52	5	19	IN THE DISPATCHER'S ROOM AT SHADY GROVE. STAFF IN VERTICAL POSITION AT DISPATCHER'S CHAIR.
MET047	AQ	11:13-11:15	8-1 53	5	19	IN THE DISPATCHER'S ROOM AT SHADY GROVE. STAFF IN HORIZONTAL POSITION 1.25 m (4.1 ft) ABOVE FLOOR WITH MONITORS AS THE REFERENCE.
MET048	AR	11:15-11:17	8-1 54	5	18	IN THE DISPATCHER'S ROOM AT SHADY GROVE. STAFF IN HORIZONTAL POSITION 1.25 m (4.1 ft) ABOVE FLOOR WITH MOCK-UP PANEL AS THE REFERENCE.
MET049	AS	12:05-12:07	3-1 1	5	34	CENTER OF AISLE IN CENTER OF A 3000 SERIES CAR ON RED LINE FROM ROCKVILLE. STAFF IN VERTICAL POSITION.
MET050	AT	12:08-12:08	3-1 2	5	11	CENTER OF A 3000 SERIES CAR. STAFF IN HORIZONTAL POSITION AT FLOOR LEVEL ALONG THE AXIS OF THE CAR.
MET051	AU	12:10-12:10	3-1 3	5	9	CENTER OF A 3000 SERIES CAR ON RED LINE. STAFF IN HORIZONTAL POSITION AT FLOOR LEVEL TRANSVERSE TO THE AXIS OF THE CAR.

TABLE A-1.

INDEX OF REPETITIVE WAVEFORM DATA WMATA METRORAIL  
 May 19 - May 20, 1992 (CONT'D)

DATA FILE NUMBER	APPENDIX CONTAINING DATA	DATE/TIME	PROBE LOCATION FIG. STAFF REF.	SAMPLE INTERVAL, SECONDS	NUMBER OF SAMPLES	LOCATION AND TYPE OF MEASUREMENT
MET052	AV	12:11-12:11	3-1 3	5	3	CENTER OF A 3000 SERIES CAR ON RED LINE. STAFF IN HORIZONTAL POSITION 1 m (3.3 ft) ABOVE THE FLOOR, TRANSVERSE TO THE AXIS OF THE CAR.
MET053	AW	12:11-12:14	3-1 2	5	28	CENTER OF A 3000 SERIES CAR. STAFF IN HORIZONTAL POSITION 1 m (3.3 ft) ABOVE THE FLOOR, ALONG THE AXIS OF THE CAR.
MET054	AX	14:17-14:28	5-1 12	5	133	BENEATH METRORAIL AT HIGHWAY UNDERPASS NEAR ROCKVILLE. STAFF IN VERTICAL POSITION.
MET055	AY	14:33-14:33	5-1 12	5	6	SAME AS MET054.
MET056	AZ	14:53-14:57	5-2 14	5	15	ALONG WAYSIDE 4.4 km (2.75 mi) SOUTH OF ROCKVILLE. STAFF IN A HORIZONTAL POSITION 1 m (3.3 ft) ABOVE GROUND WITH FENCE AS THE REFERENCE.

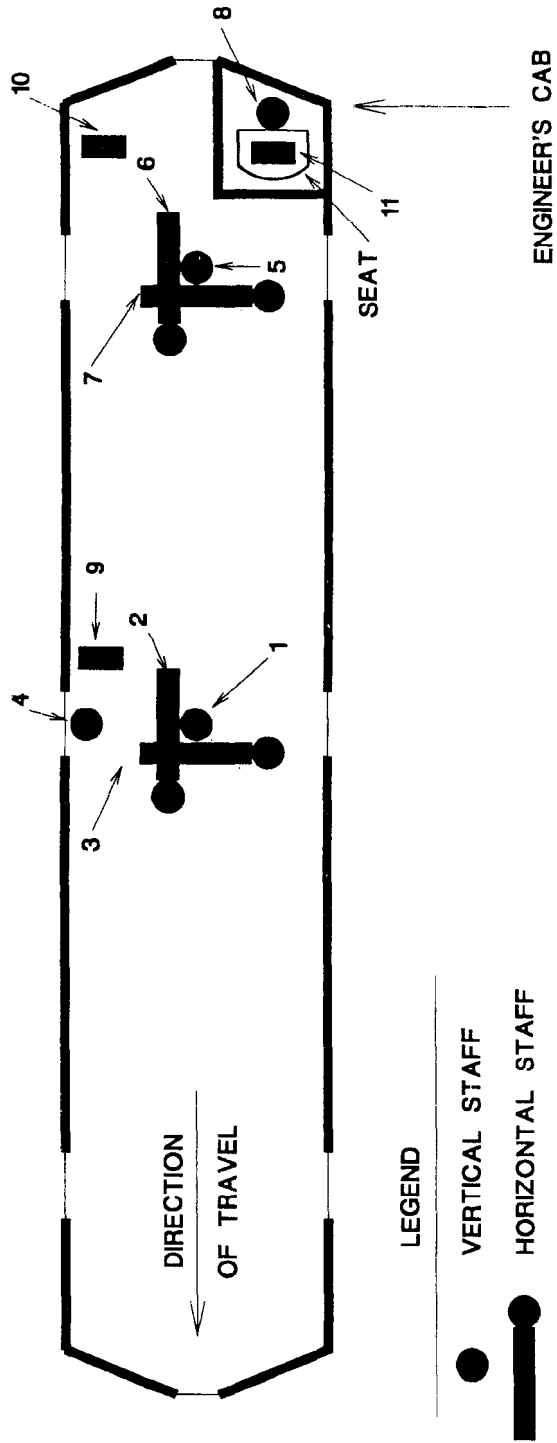

## CAR LAYOUT

FIGURE A-1. CAR LAYOUT

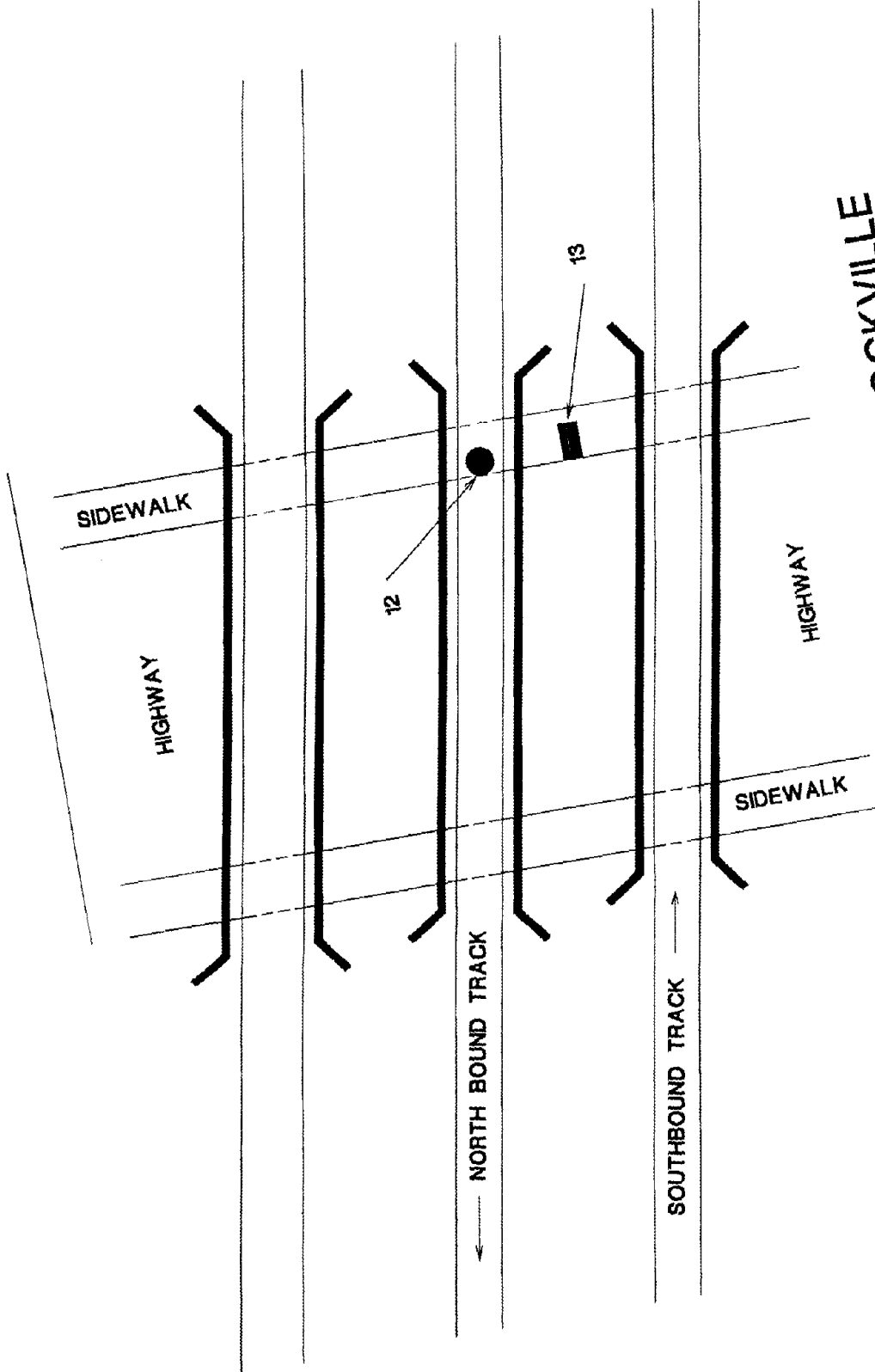

**HIGHWAY UNDERPASS AT ROCKVILLE**

**FIGURE A-2. HIGHWAY UNDERPASS AT ROCKVILLE**

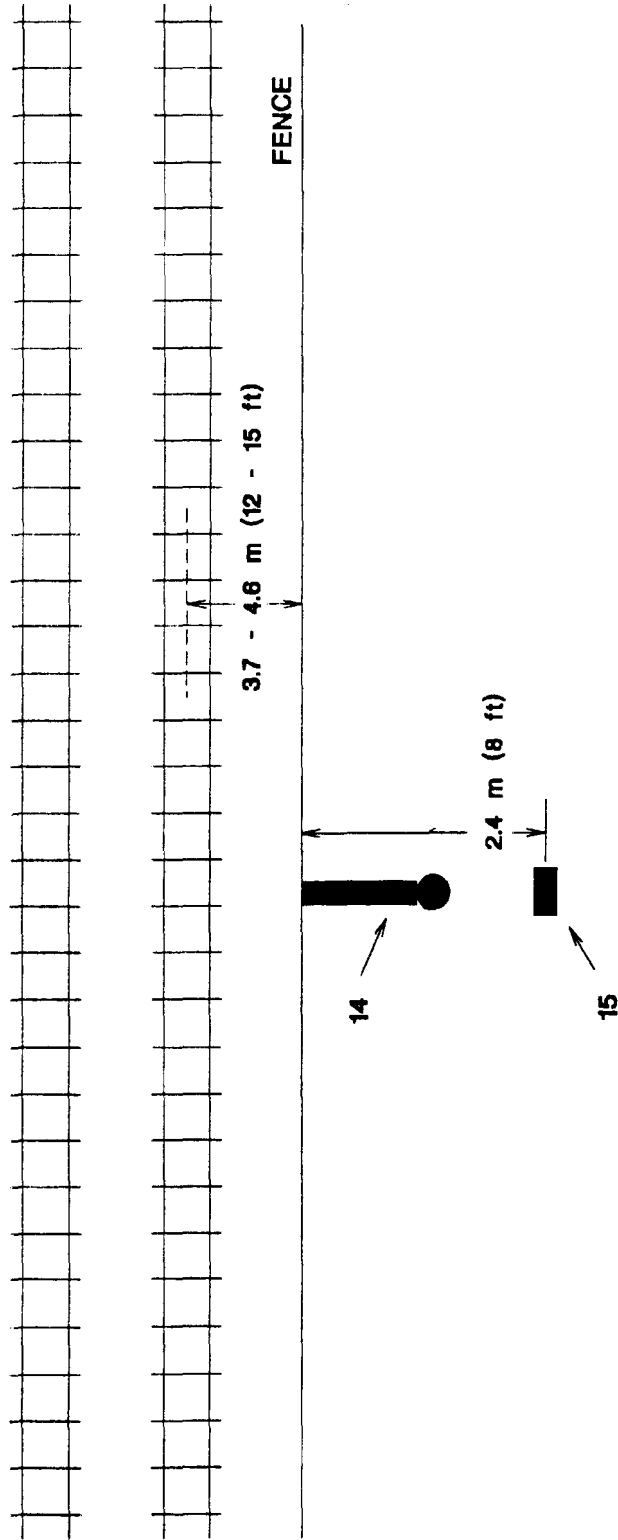

# AT WAYSIDE, SOUTH OF SHADY GROVE

FIGURE A-3. AT WAYSIDE, SOUTH OF SHADY GROVE

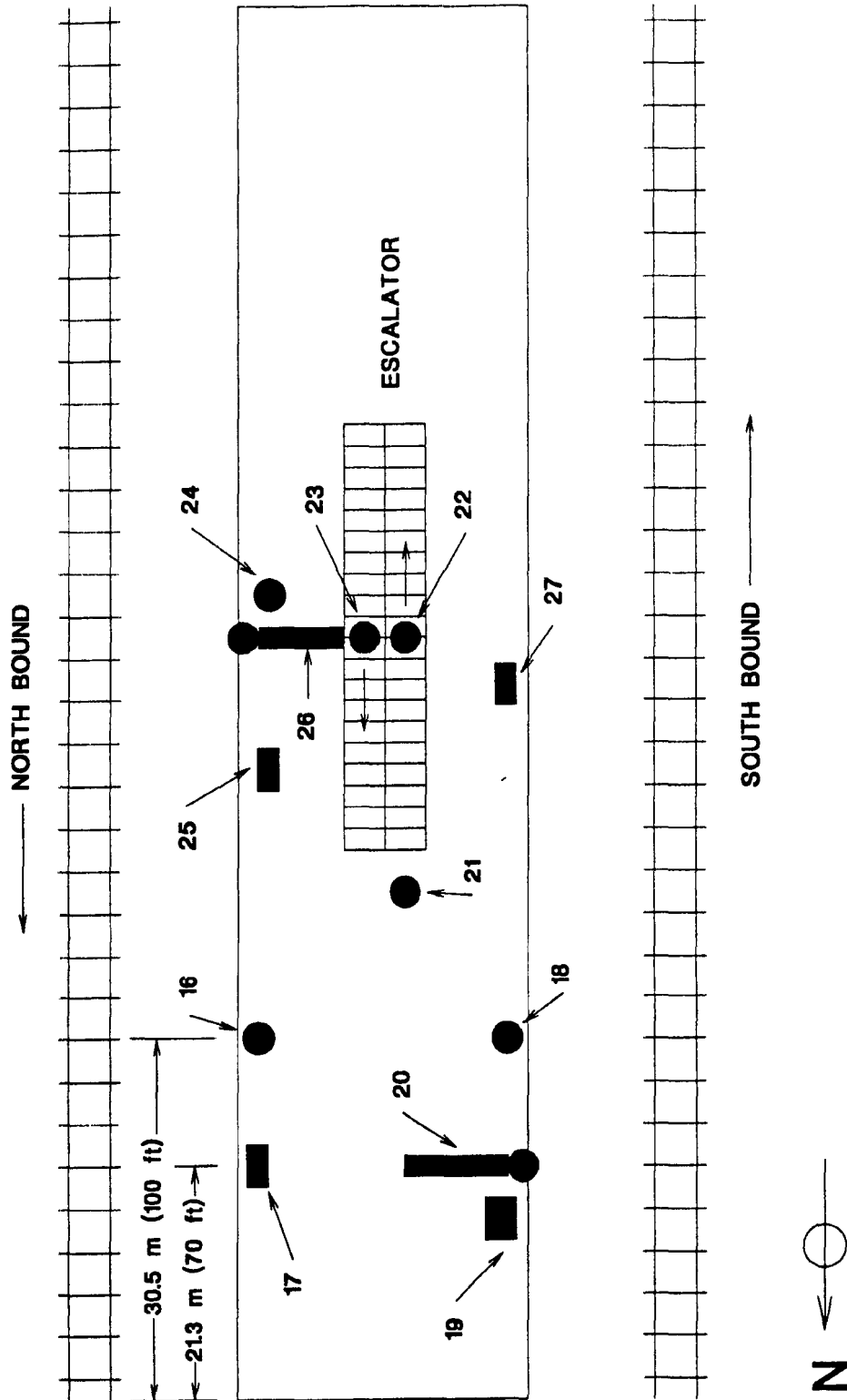

# PLATFORM AT GROSVENOR

FIGURE A-4. PLATFORM AT GROSVENOR

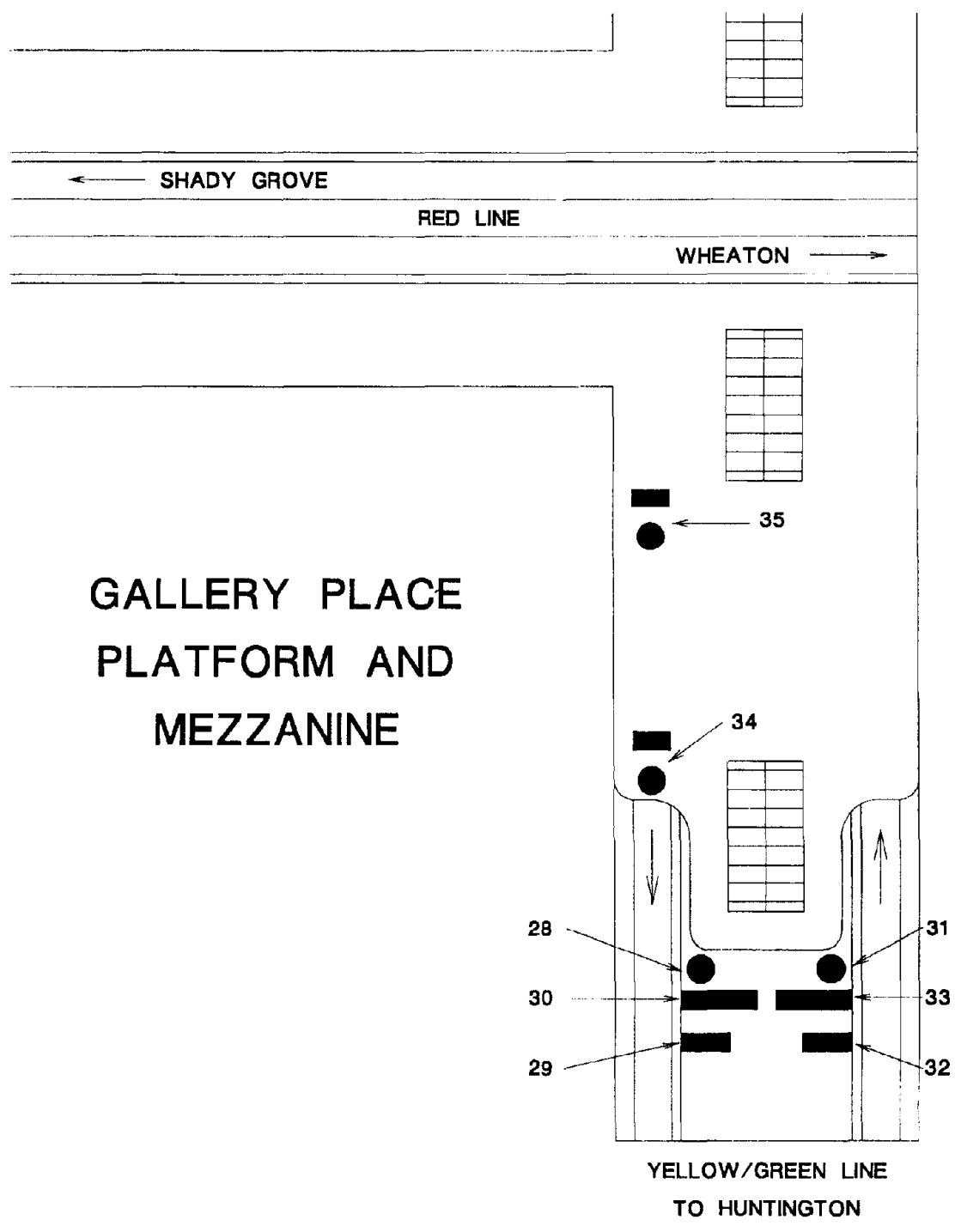

**FIGURE A-5. GALLERY PLACE PLATFORM AND MEZZANINE**



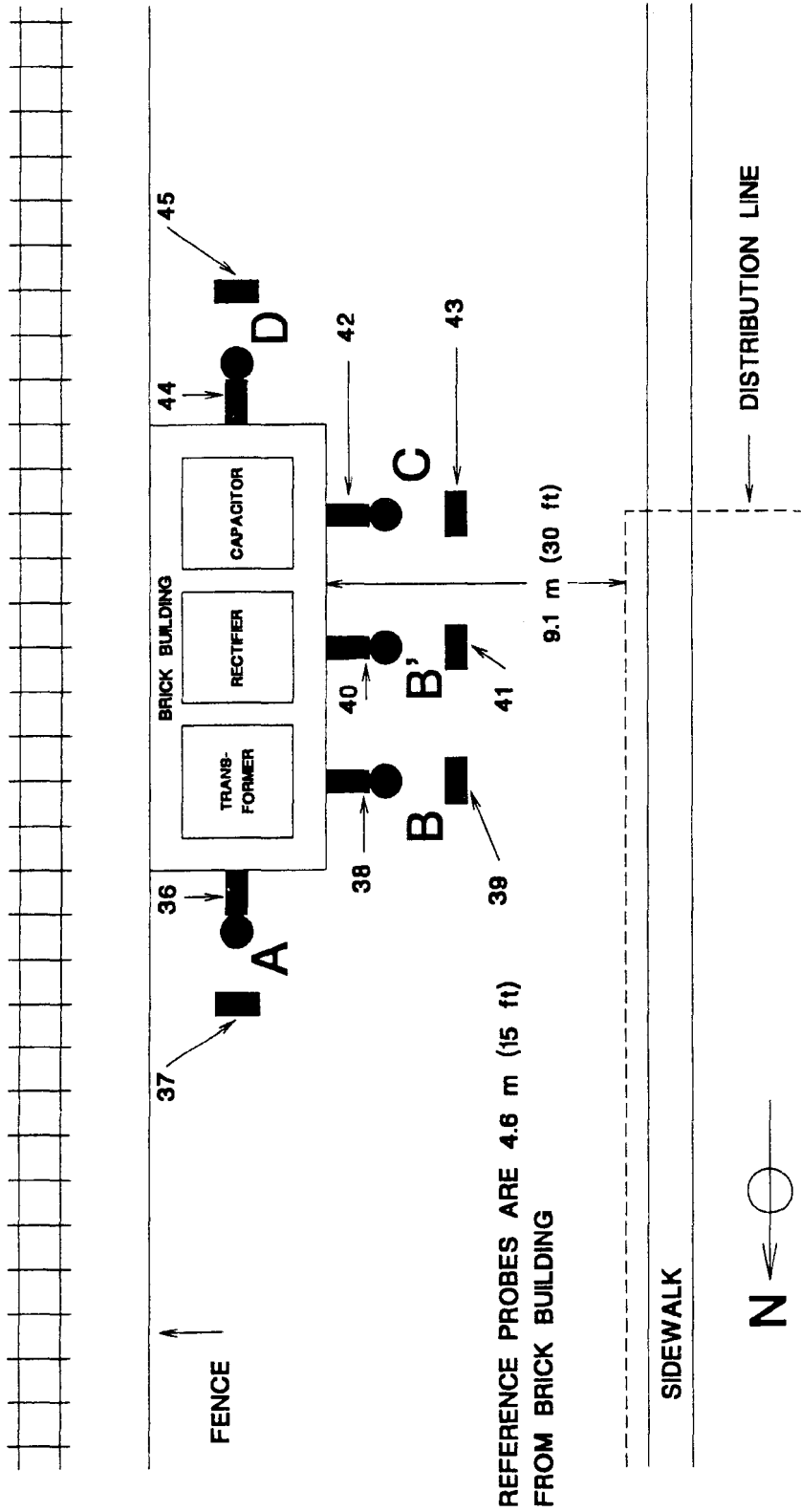

# TRACTION POWER SUPPLY STATION SOUTH OF SHADY GROVE

FIGURE A-6. TRACTION POWER SUPPLY STATION SOUTH OF SHADY GROVE

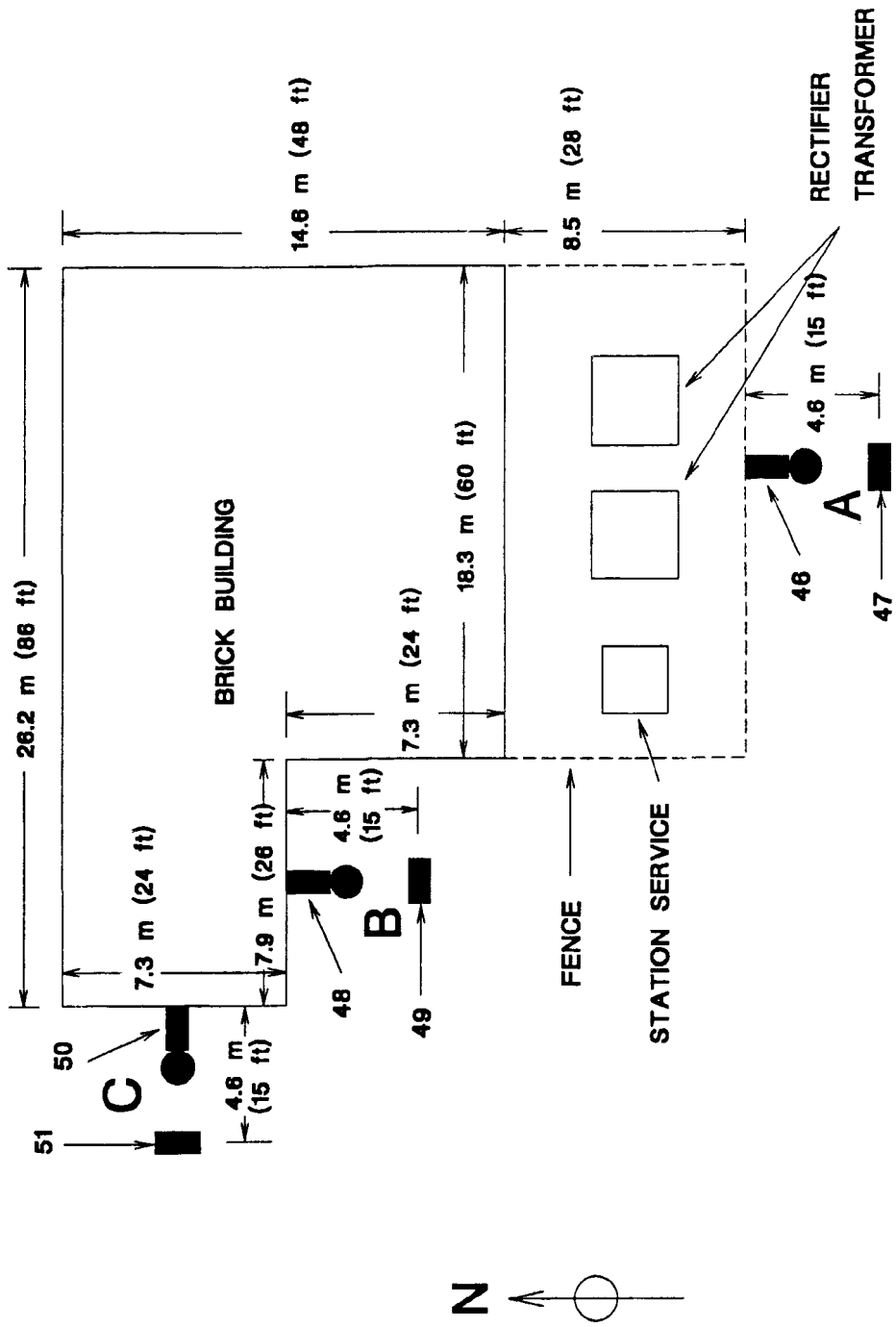

# SHADY GROVE TRACTION POWER SUPPLY STATION

FIGURE A-7. SHADY GROVE TRACTION POWER SUPPLY STATION

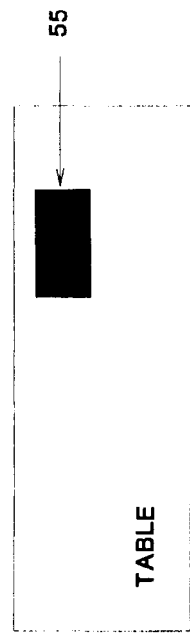
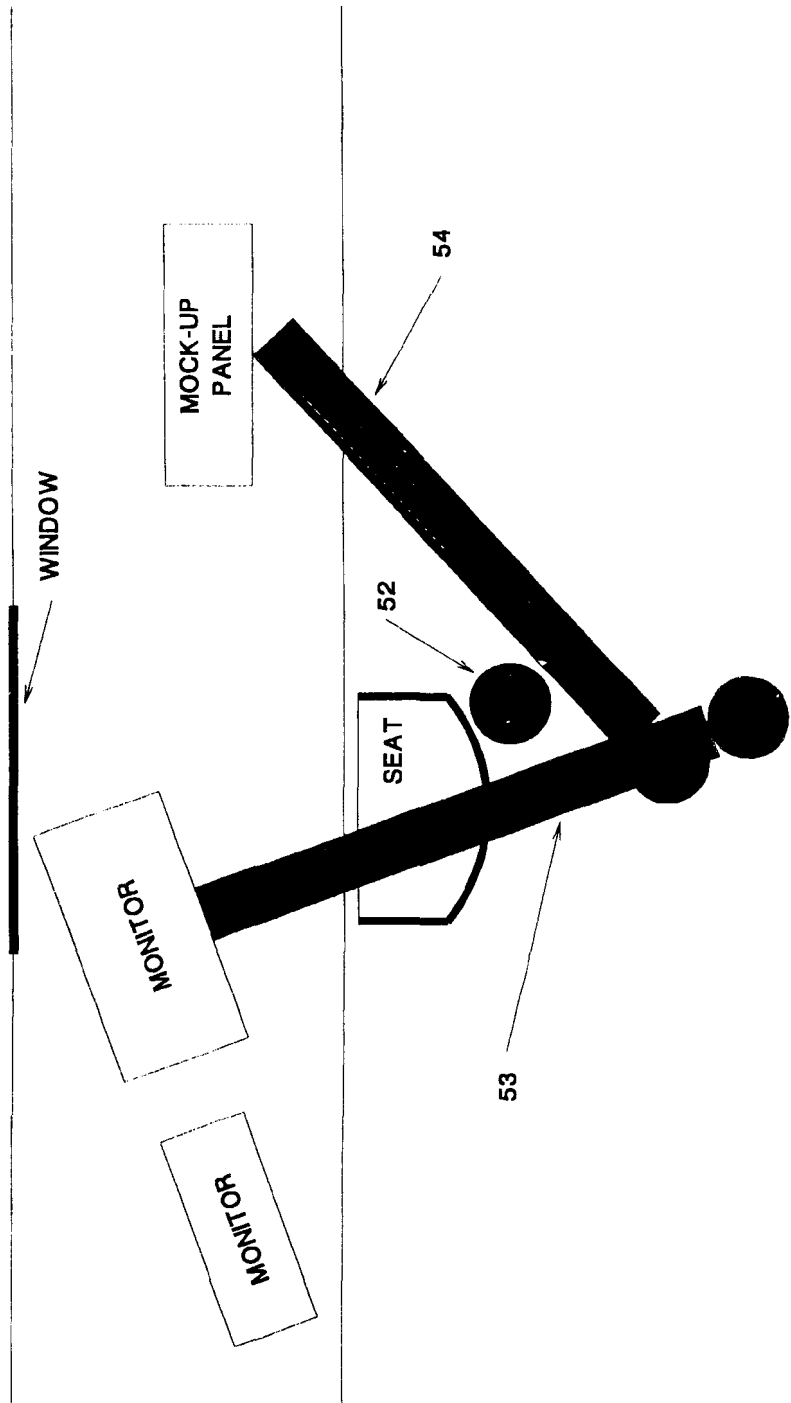

DISPATCHER'S ROOM AT SHADY GROVE

FIGURE A-8. DISPATCHER'S ROOM AT SHADY GROVE

The table of measurement parameters also contains various parameters from the waveform sampling and subsequent Fourier transformation of the waveform data that affect the interpretation of the magnetic field frequency spectra. The tabulated maximum frequency and minimum frequency are center frequencies of the upper and lower components of the Fourier transform. The spectral bandwidth is the interval between frequency components in the Fourier transform and is effectively the smallest increment in frequency that can be resolved in the frequency spectrum. The spectral bandwidth parameter is also important to the reader because the intensity of broadband magnetic field components (as opposed to fields at unique discrete frequencies) is proportional to the square root of the bandwidth. Consequently, to compare the spectral data for broadband signals contained in these appendices to values reported by others, one must make the appropriate bandwidth adjustments to the data.

The final items on the table of measurement parameters are listings of any missing data or saturated data within that particular dataset. If a sensor was known to be inoperative or was inadvertently not connected, the faulty data was deleted and identified as "missing data." In a relatively small number of cases, the total magnetic field level at a measurement point exceeded the measurement capability of a fluxgate magnetometer. Those cases are identified as "saturated data" if even one of the three orthogonal components exceeded the 5 Gauss capability of the sensor. Since the time varying field measurements were in most cases derived from the same sensor as the static field measurement, saturation of the sensor from high static field levels also compromises the time varying magnetic field measurement. A somewhat more frequent occurrence was the failure of the programmable gain amplifiers in the portable waveform capture system unit to achieve the optimal gain settings when the magnetic field levels were fluctuating rapidly from one sample point to the next. (The system is programmed in this way so that it does not totally miss a sample interval while "hunting" for the appropriate gain settings.) While these autoranging failures compromise the validity of the measurement along one of the three orthogonal axes, that effect is not necessarily fatal to the validity of the resultant field measurement. Nevertheless, autoranging failures are listed in the table of saturated data.

#### Field by Frequency and Time Plots for Each Sensor

The first set of data plots in each appendix is the field by frequency and time plots for each magnetic field sensor. These plots are described in more detail in Section 2 of this report. The top frame of each page shows the static magnetic field component and time varying components up to 100 Hz. The lower frame has the static field suppressed to show the time varying magnetic field components in more detail. Although all of the time varying magnetic measurements extended out to a maximum frequency of 2560 Hz, only that portion of the spectrum containing fields of significant amplitude were plotted.

### Field by Distance and Time Plots

The next group of graphs in each appendix show the intensity of the field in each of six frequency bands as a function of distance from some reference point (such as floor of the vehicle, etc.) over the time of the measurements. These graphs were created for each set of measurements whether the spatial distribution was expected to help identify the source of the magnetic field or establish an attenuation rate which would be useful for predicting field intensities at other distances from the source.

The spatial sampling of the magnetic field level is by necessity limited to only the few points where magnetic field sensors were placed (see the sketches of sensor locations in this appendix). From this relatively sparse sample, the contours of the field by distance and time plots were generated by a computer program which attempts to fit a surface to the available data points. These plots are therefore very accurate at the sensor locations but represent a "best fit" approximation of the field levels between sensor locations. In those cases where the attenuation data are orderly and consistent, the contours are expected to be a good approximation of reality. However, in the cases where field values are erratic or inconsistent between probe locations, the validity of the contour is more uncertain at places other than the sample locations. In evaluating these curves, the reader should be cognizant of the actual measurement locations and place the most credibility in the data at those locations.

### Summary Statistics

Statistical summaries of individual datasets are also included in the appendix. Those summaries consist of tables of field strength and variability parameters.



APPENDIX B

DATASET MET001  
CENTER OF AISLE, CENTER OF CAR #1173

Measurement Setup Code:        Staff:    1    Reference: -  
   Drawing: A-1

Vehicle Status:                    Traveling on the Red Line

Measurement Date:                May 19, 1992

Measurement Time:                Start:    08:25:01  
   End:        08:28:48

Number of Samples:                18

Programmed Sample Interval:    5 sec

Actual Sample Interval:         13.4 sec

Frequency Spectrum Parameters

<u>Probe Type:</u>	<u>Wideband</u>	<u>Static</u>
Maximum Frequency (Hz)	2560	100
Minimum Frequency (Hz)	5	0
Spectral Bandwidth (Hz)	5	1

Missing Data: No reference probe

Saturated Data - Wideband:	<u>Sensor</u>	<u>Sample</u>	<u>Time (sec)</u>
	10cm	1	0
	10cm	11	134
	10cm	16	201
	60cm	8	94
	60cm	11	134
	110cm	7	80
	110cm	11	134
	110cm	15	188

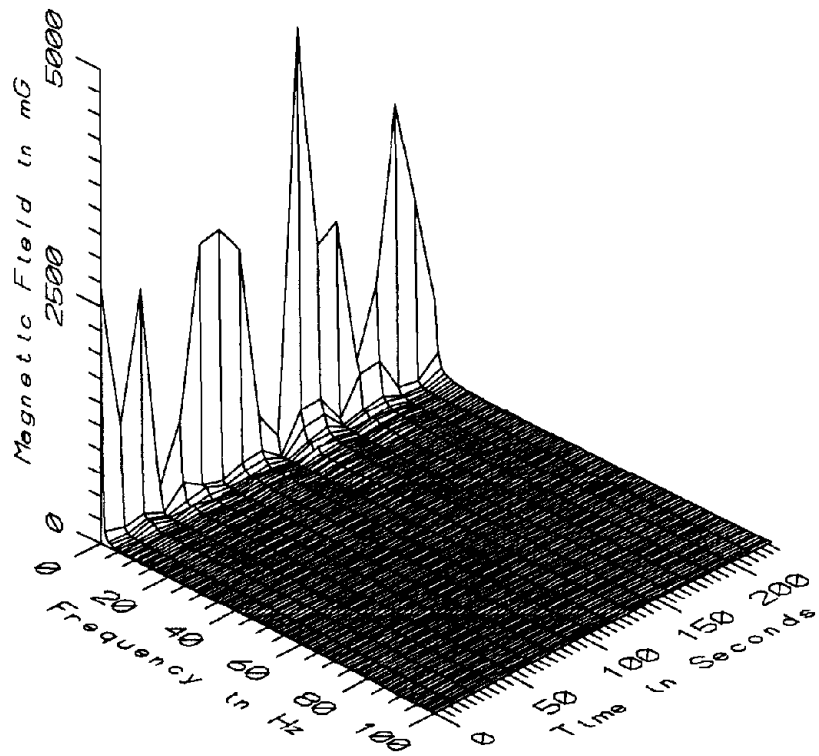

MET001 - 10cm ABOVE FLOOR, CENTER OF AISLE, CENTER OF CAR 1173

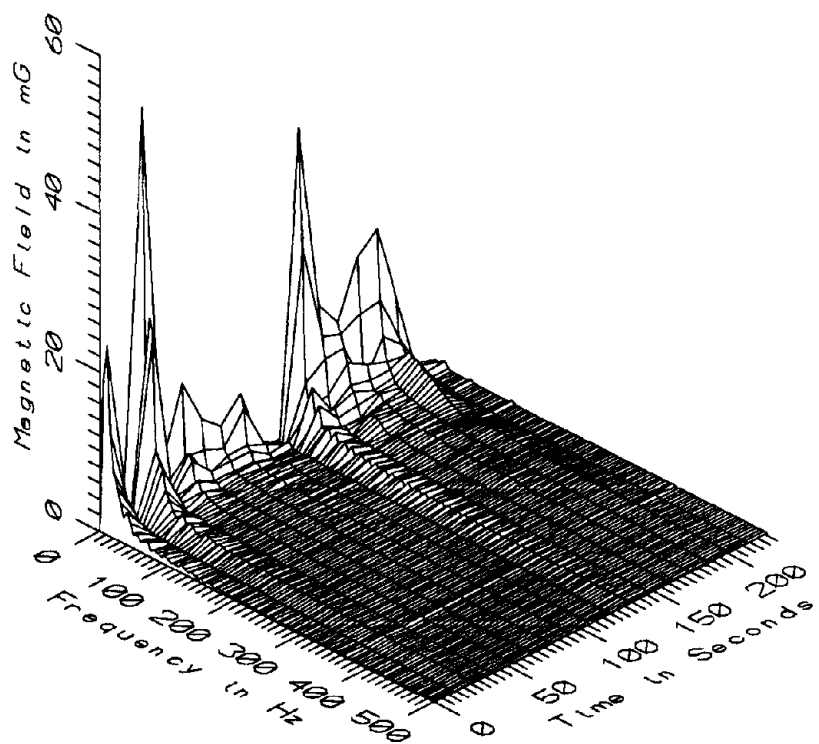

MET001 - 10cm ABOVE FLOOR, CENTER OF AISLE, CENTER OF CAR 1173



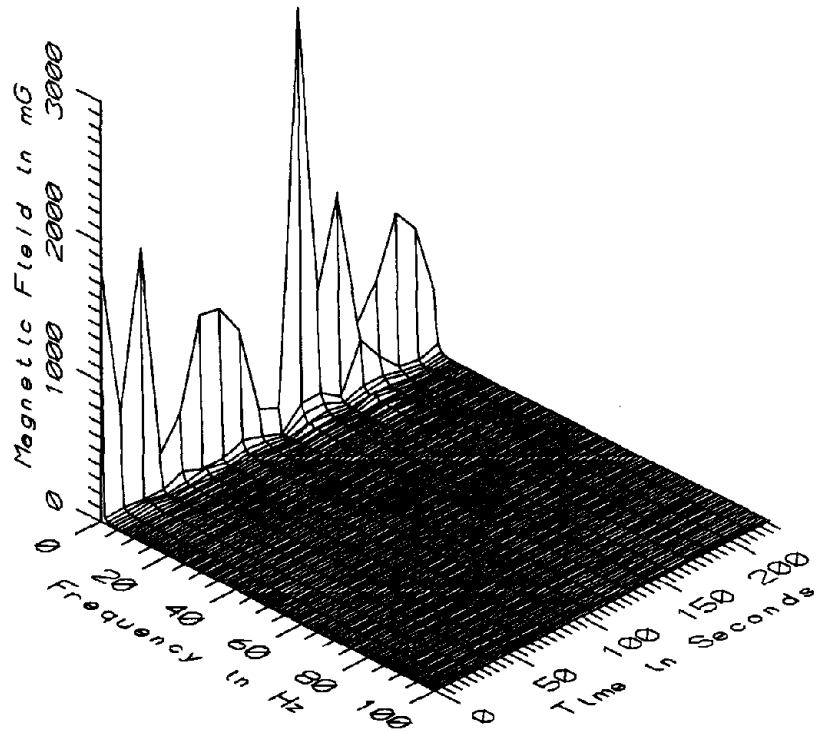

MET001 - 60cm ABOVE FLOOR, CENTER OF AISLE, CENTER OF CAR 1173

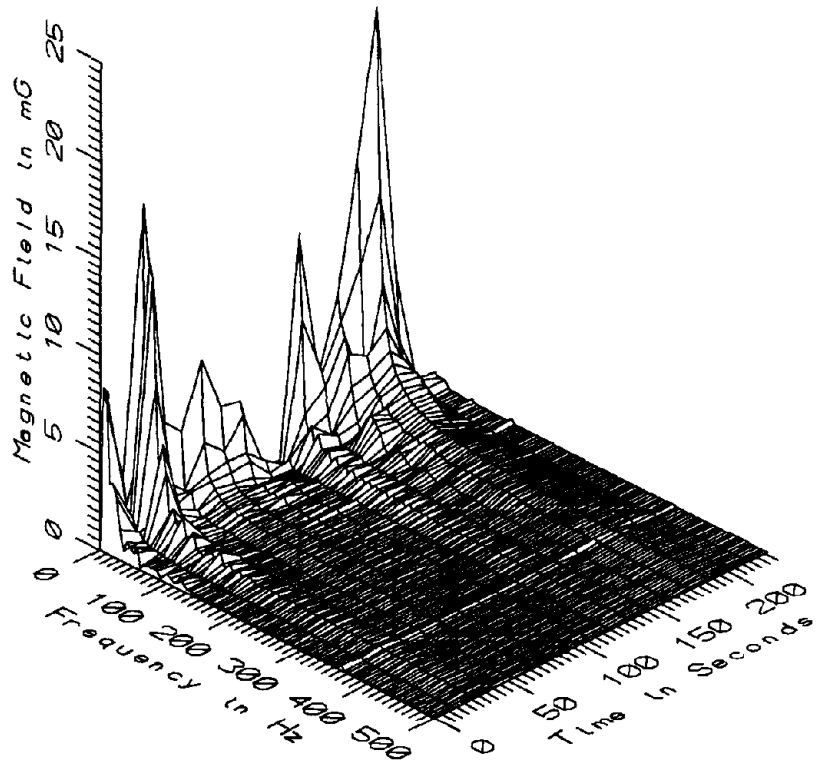

MET001 - 60cm ABOVE FLOOR, CENTER OF AISLE, CENTER OF CAR 1173

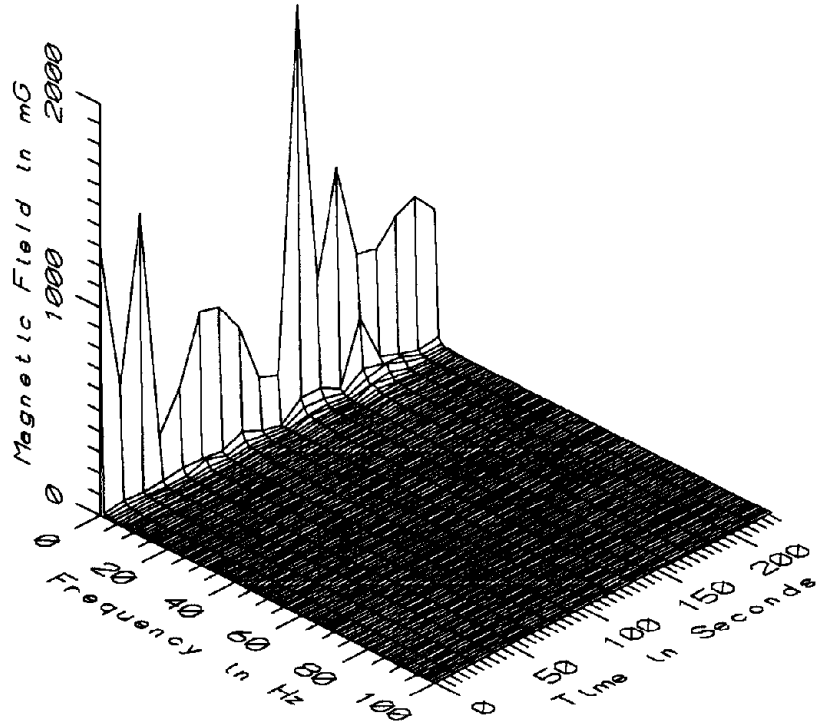

MET001 - 110cm ABOVE FLOOR, CENTER OF AISLE, CENTER OF CAR 1173

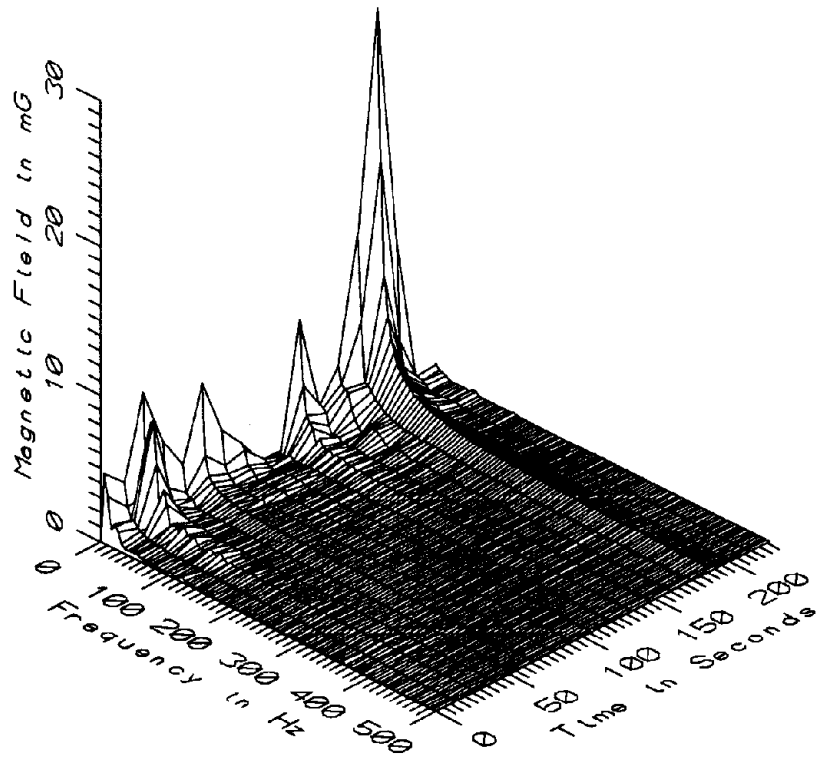

MET001 - 110cm ABOVE FLOOR, CENTER OF AISLE, CENTER OF CAR 1173

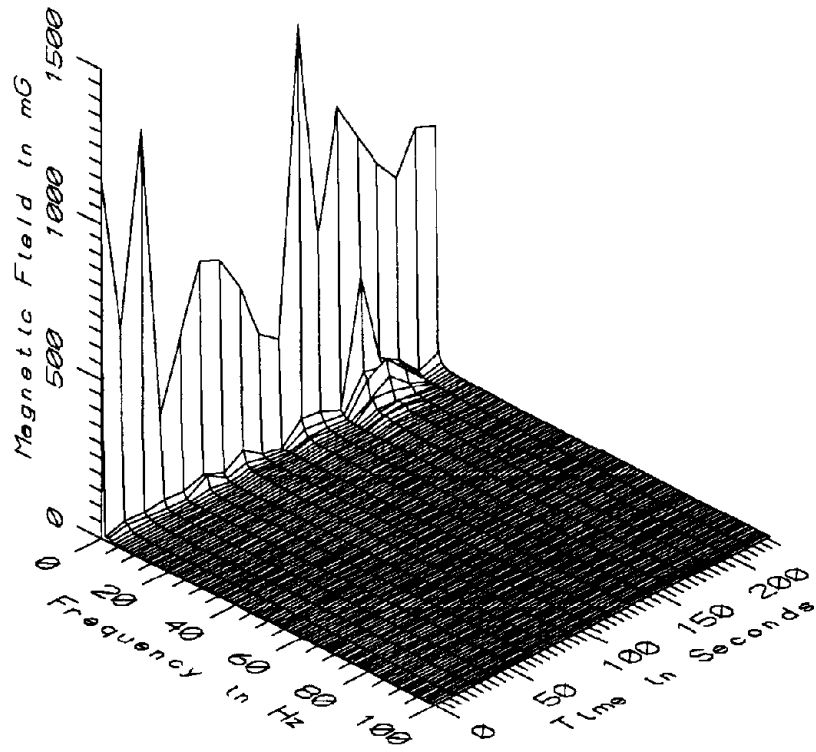

MET001 - 160cm ABOVE FLOOR, CENTER OF AISLE, CENTER OF CAR 1173

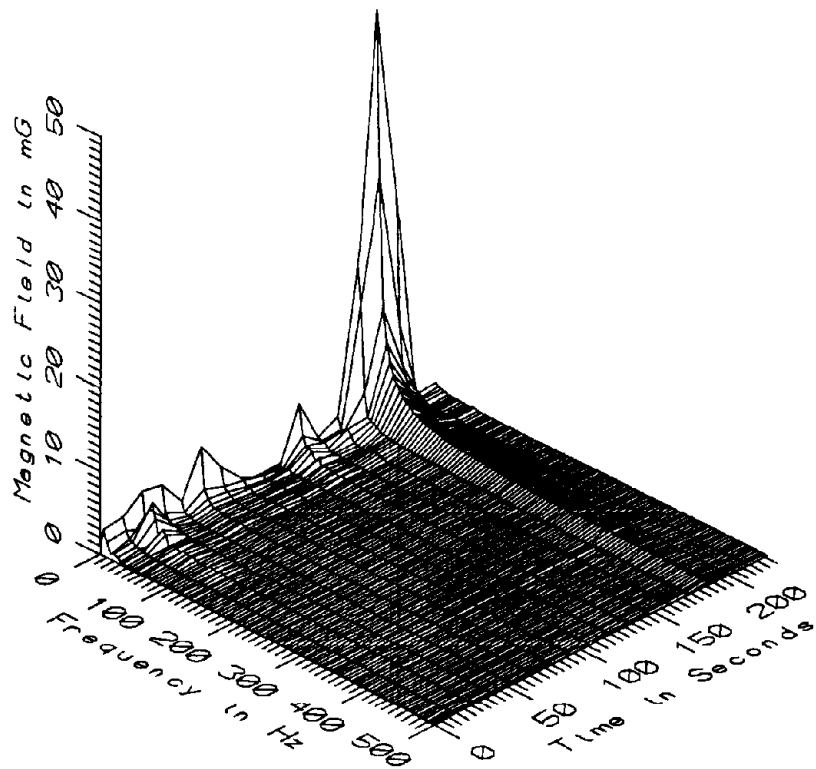

MET001 - 160cm ABOVE FLOOR, CENTER OF AISLE, CENTER OF CAR 1173

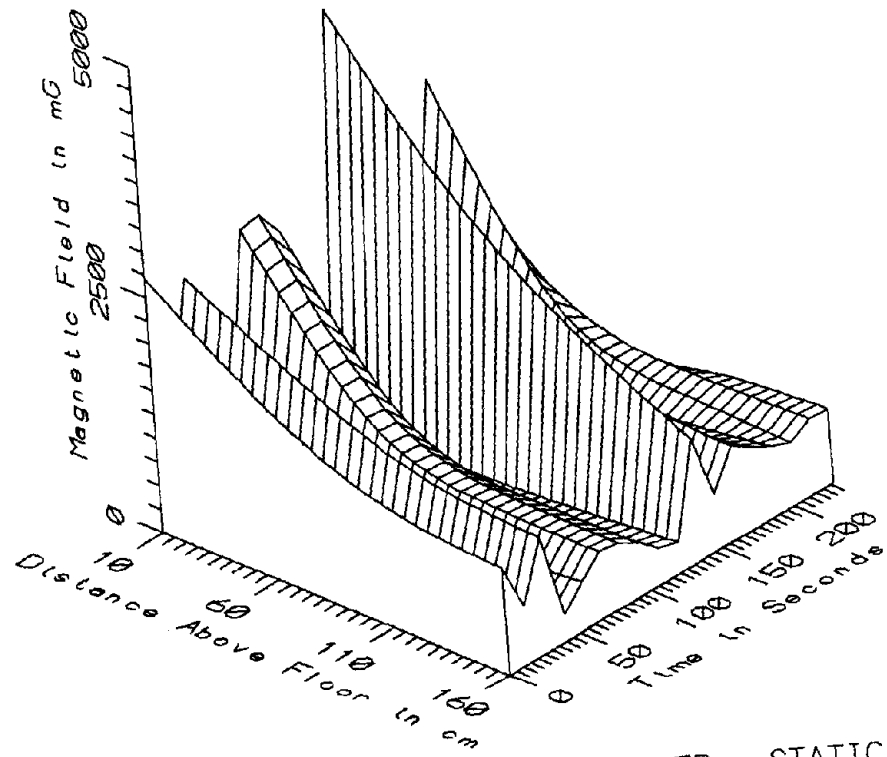

MET001 - CENTER OF AISLE, CENTER OF CAR 1173 - STATIC

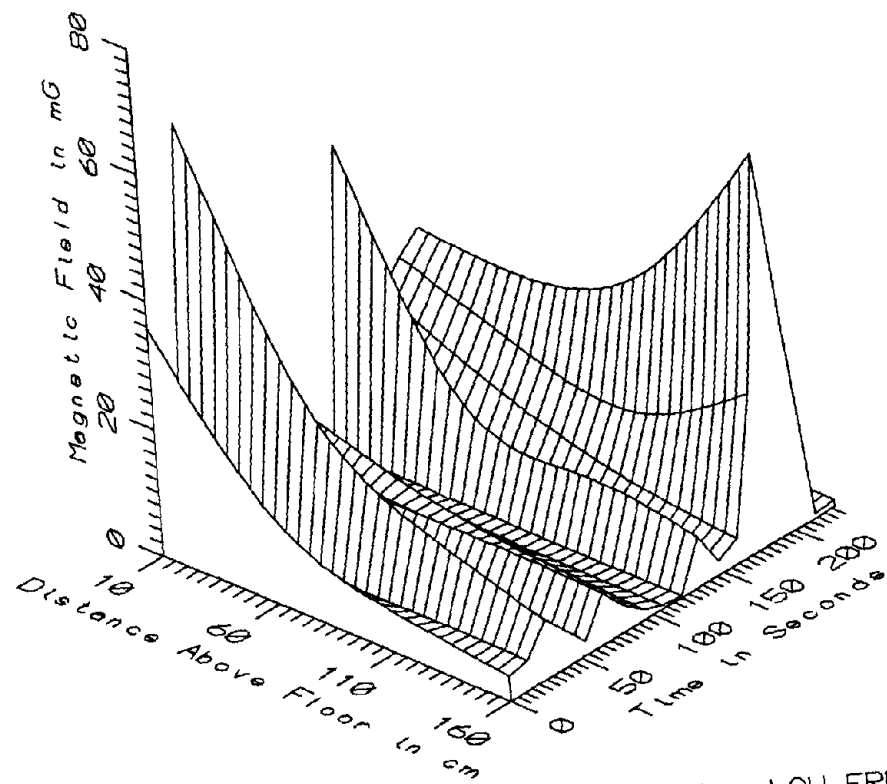

MET001 - CENTER OF AISLE, CENTER OF CAR 1173 - LOW FREQ, 5-45Hz

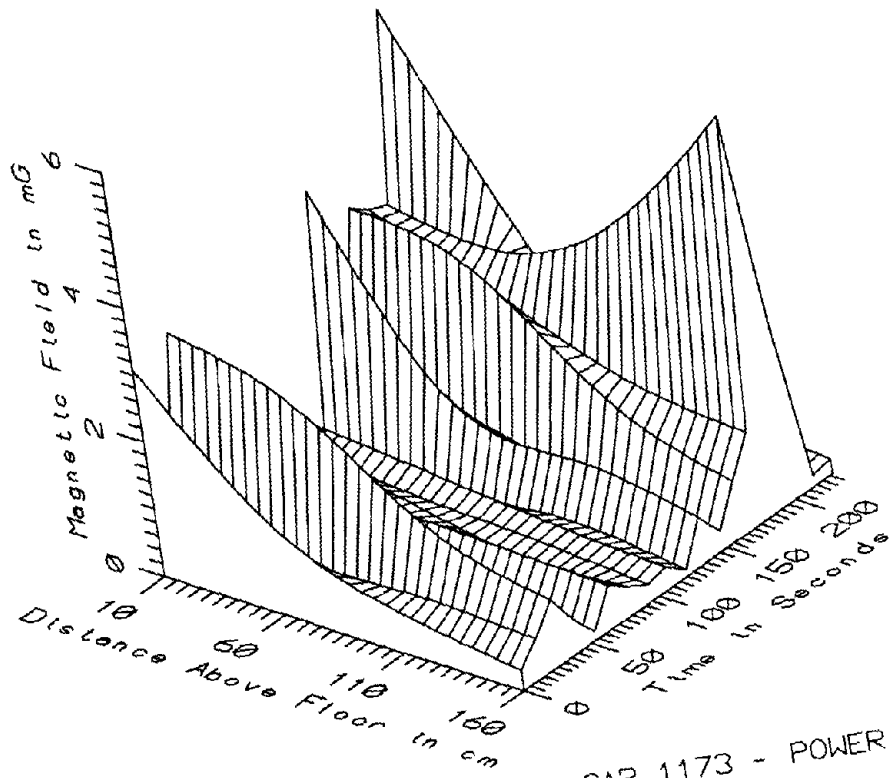

MET001 - CENTER OF AISLE, CENTER OF CAR 1173 - POWER FREQ, 50-60Hz

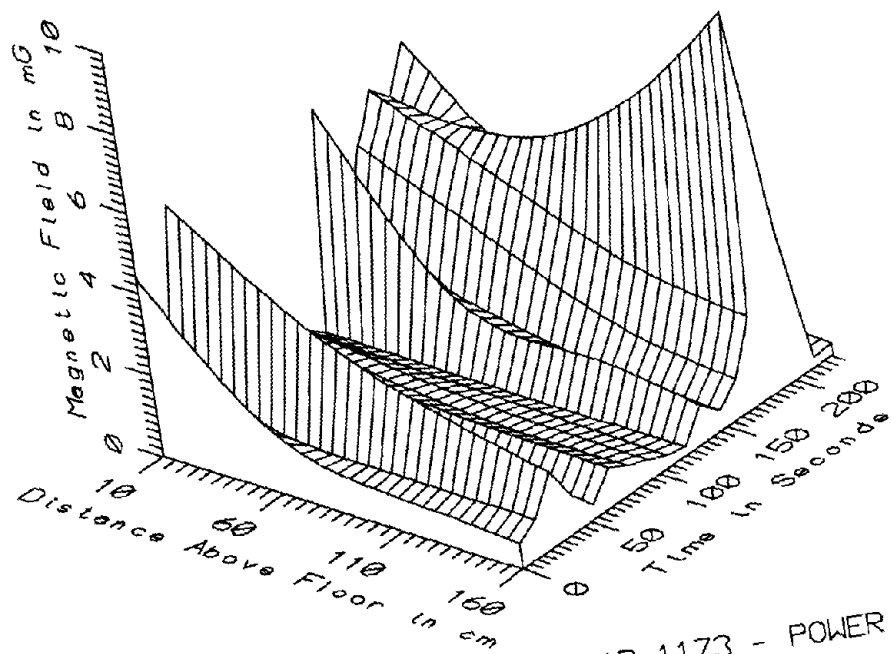

MET001 - CENTER OF AISLE, CENTER OF CAR 1173 - POWER HARM, 65-300Hz

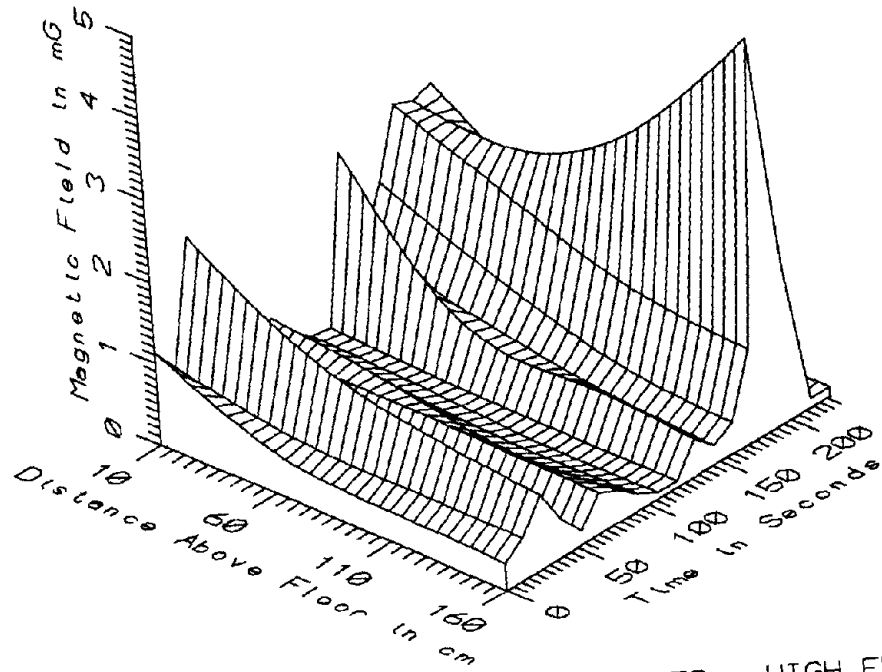

MET001 - CENTER OF AISLE, CENTER OF CAR 1173 - HIGH FREQ, 305-2560Hz

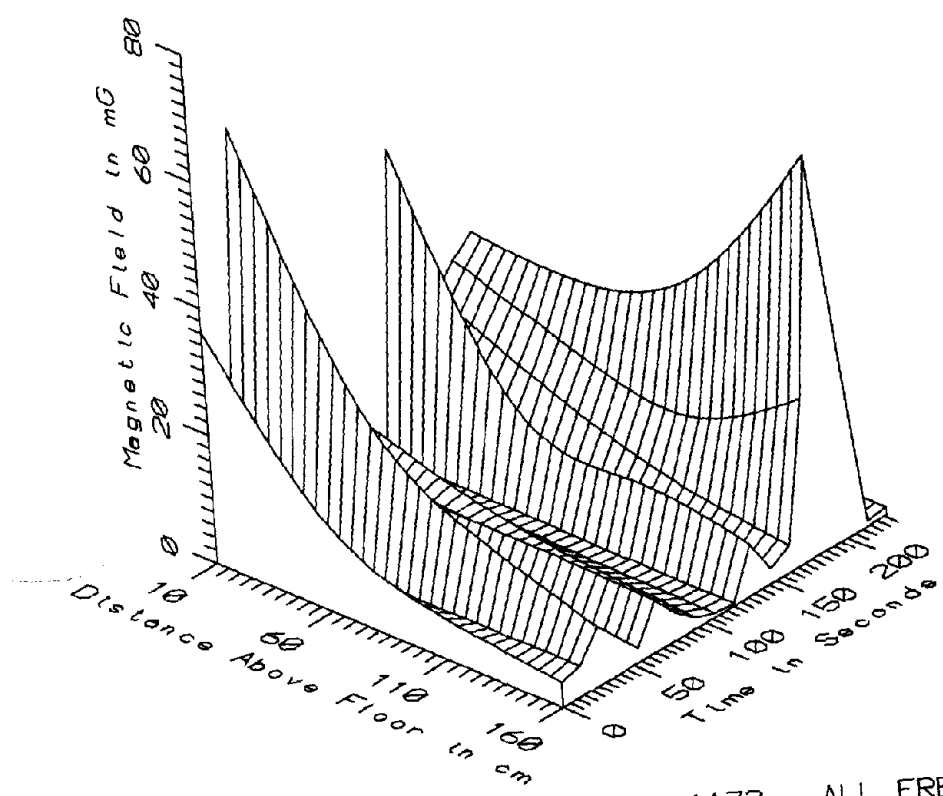

MET001 - CENTER OF AISLE, CENTER OF CAR 1173 - ALL FREQ, 5-2560Hz

IMET001 - CENTER OF AISLE, CENTER OF CAR #1173		TOTAL OF 18 SAMPLES				
FREQUENCY BAND	HEIGHT ABOVE FLOOR (cm)	MINIMUM MAGNETIC FIELD (mG)	MAXIMUM MAGNETIC FIELD (mG)	AVERAGE MAGNETIC FIELD (mG)	STANDARD DEVIATION (mG)	COEFFICIENT OF VARIATION (%)
STATIC	10	205.11	4395.54	1779.76	1134.12	63.72
	60	172.01	2964.69	984.82	699.25	71.00
	110	233.17	1988.68	749.85	443.06	59.09
	160	290.89	1319.42	742.89	291.48	39.24
5-45Hz	10	0.84	64.48	17.89	17.05	95.32
LOW FREQ	60	0.53	28.06	9.23	8.01	86.80
	110	0.33	34.65	7.48	8.16	109.10
	160	0.39	60.79	9.54	15.09	158.29
50-60Hz	10	0.25	5.59	1.89	1.50	79.04
PWR FREQ	60	0.13	2.86	1.20	0.98	82.11
	110	0.27	3.77	0.90	0.85	94.87
	160	0.10	5.87	0.90	1.37	152.13
65-300Hz	10	0.22	5.58	2.53	2.04	80.48
PWR HARM	60	0.22	4.40	1.59	1.30	81.73
	110	0.20	6.13	1.27	1.39	109.52
	160	0.22	9.43	1.42	2.17	153.27
305-2560Hz	10	0.18	2.37	1.09	0.85	77.55
HIGH FREQ	60	0.12	2.24	0.71	0.61	85.96
	110	0.08	3.12	0.58	0.72	123.80
	160	0.07	4.79	0.70	1.11	159.58
5-2560Hz	10	0.93	64.84	18.28	17.17	93.93
ALL FREQ	60	0.60	28.46	9.51	8.16	85.84
	110	0.49	35.53	7.68	8.33	108.42
	160	0.47	61.98	9.73	15.34	157.69





APPENDIX C

DATASET MET002  
CENTER OF AISLE, REAR OF CAR #1173

Measurement Setup Code:        Staff:     5     Reference: 10  
   Drawing:  A-1

Vehicle Status:                Traveling on the Red Line

Measurement Date:             May 19, 1992

Measurement Time:            Start:     08:32:05  
   End:        08:34:55

Number of Samples:            14

Programmed Sample Interval:   5 sec

Actual Sample Interval:       13.1 sec

Frequency Spectrum Parameters

<u>Probe Type:</u>	<u>Wideband</u>	<u>Static</u>
Maximum Frequency (Hz)	2560	100
Minimum Frequency (Hz)	5	0
Spectral Bandwidth (Hz)	5	1

Missing Data: Wideband data from the reference probe

Saturated Data - Wideband:	<u>Sensor</u>	<u>Sample</u>	<u>Time (sec)</u>
	10cm	8	105
	60cm	8	105
	160cm	7	92

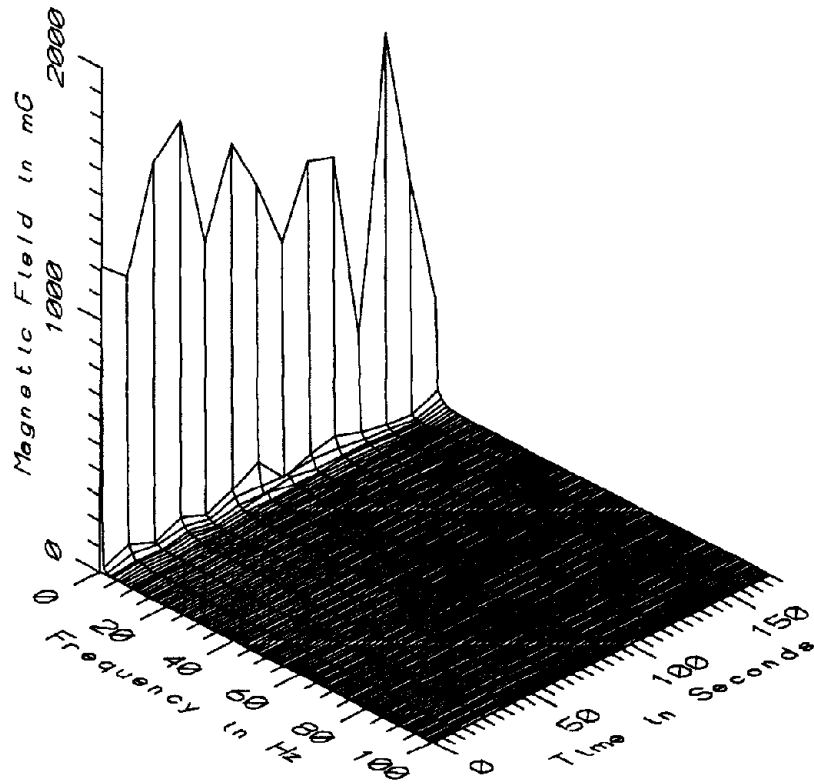

MET002 - 10cm ABOVE FLOOR, CENTER OF AISLE, REAR OF CAR 1173

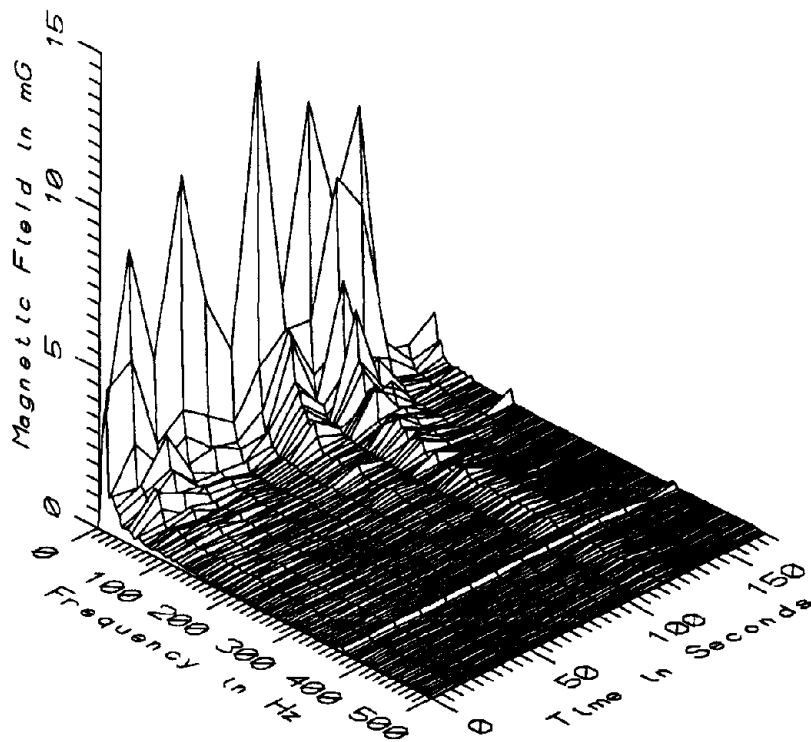

MET002 - 10cm ABOVE FLOOR, CENTER OF AISLE, REAR OF CAR 1173

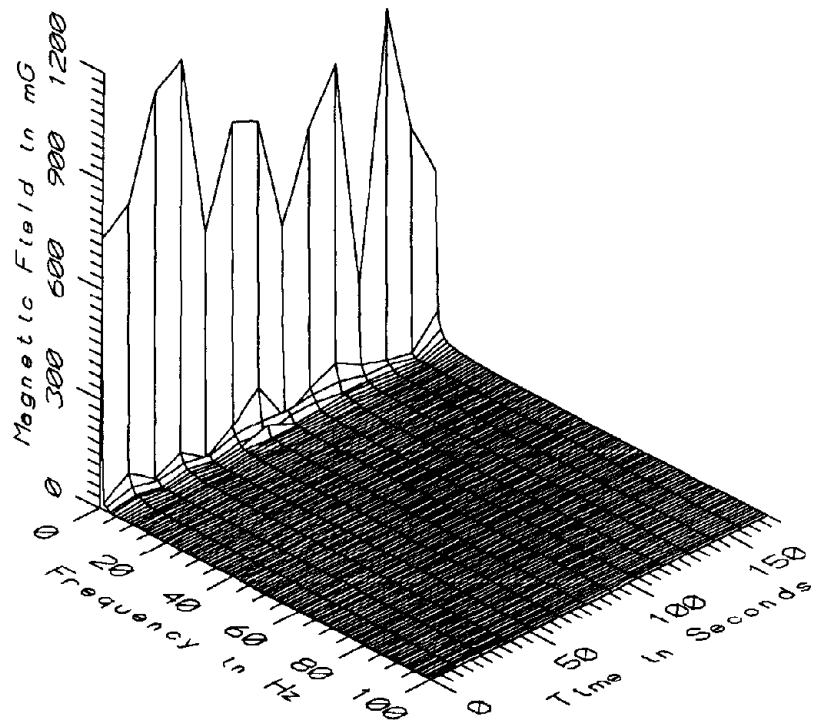

MET002 - 60cm ABOVE FLOOR, CENTER OF AISLE, REAR OF CAR 1173

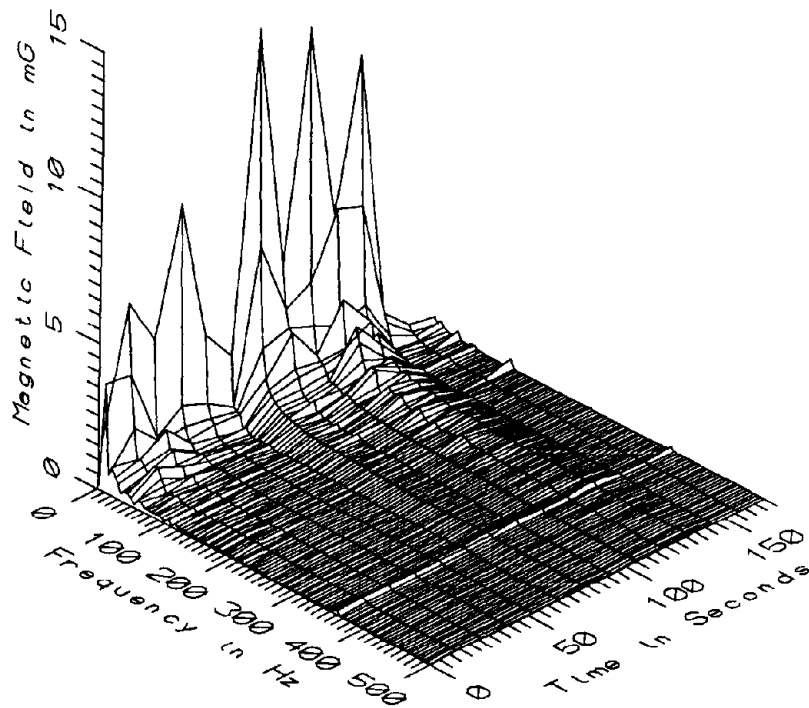

MET002 - 60cm ABOVE FLOOR, CENTER OF AISLE, REAR OF CAR 1173

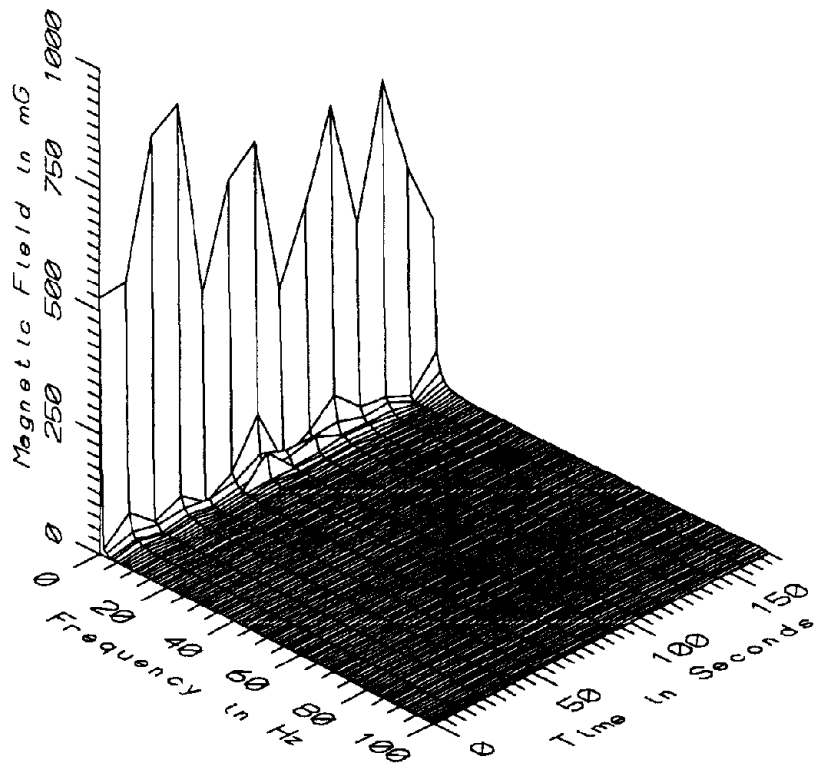

MET002 - 110cm ABOVE FLOOR, CENTER OF AISLE, REAR OF CAR 1173

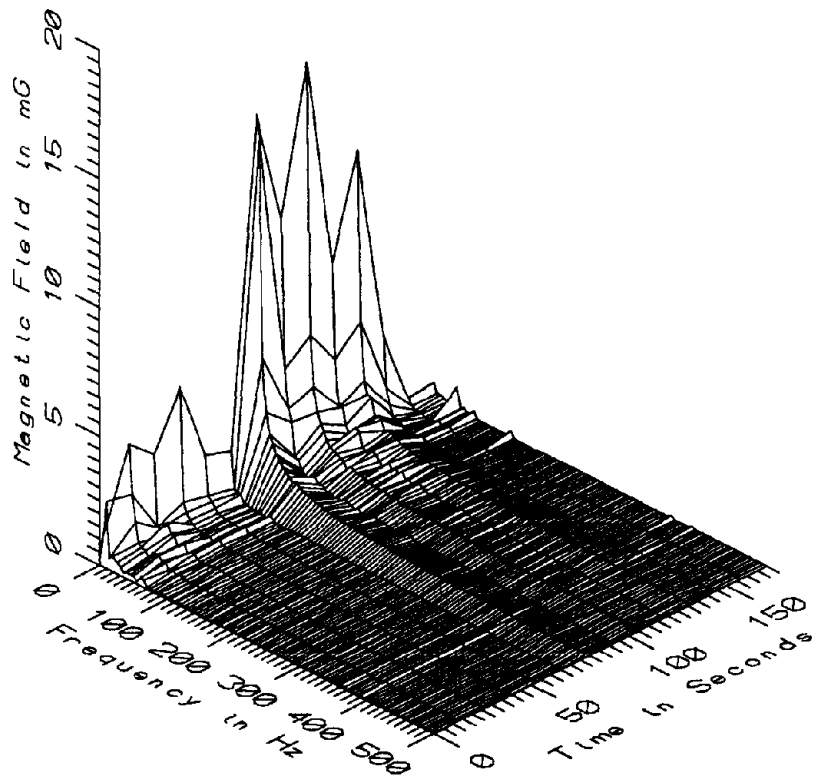

MET002 - 110cm ABOVE FLOOR, CENTER OF AISLE, REAR OF CAR 1173

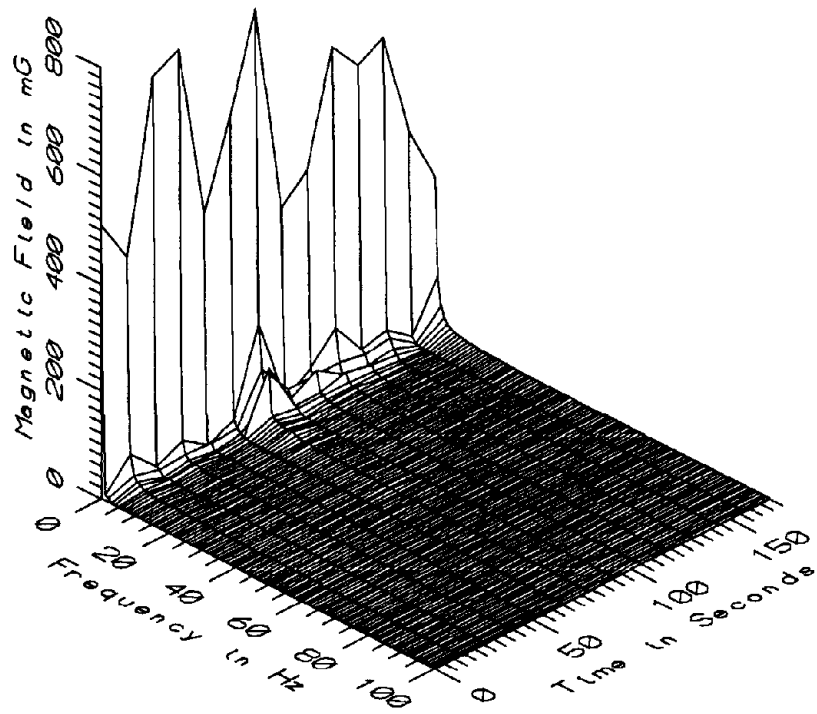

MET002 - 160cm ABOVE FLOOR, CENTER OF AISLE, REAR OF CAR 1173

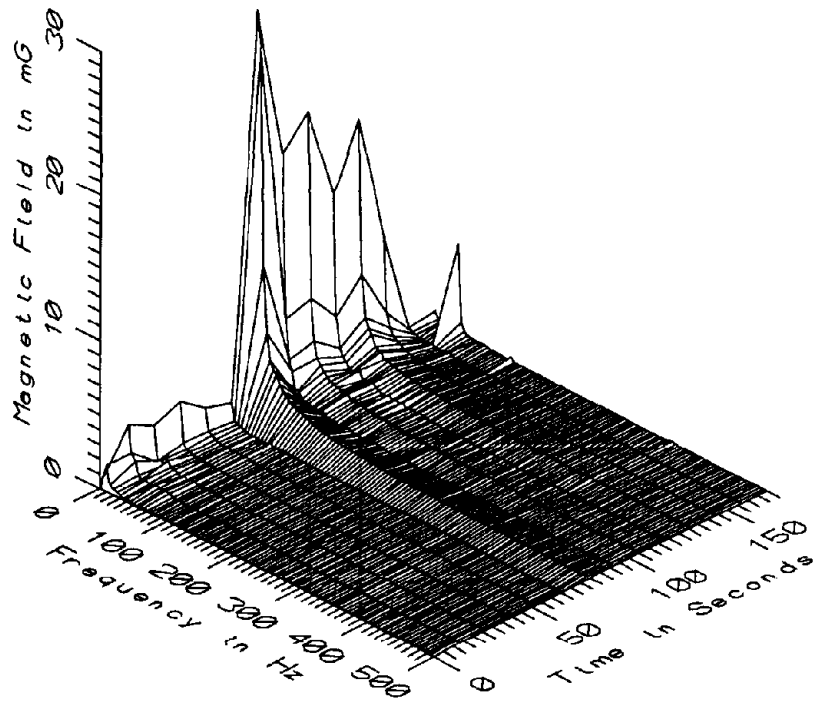

MET002 - 160cm ABOVE FLOOR, CENTER OF AISLE, REAR OF CAR 1173

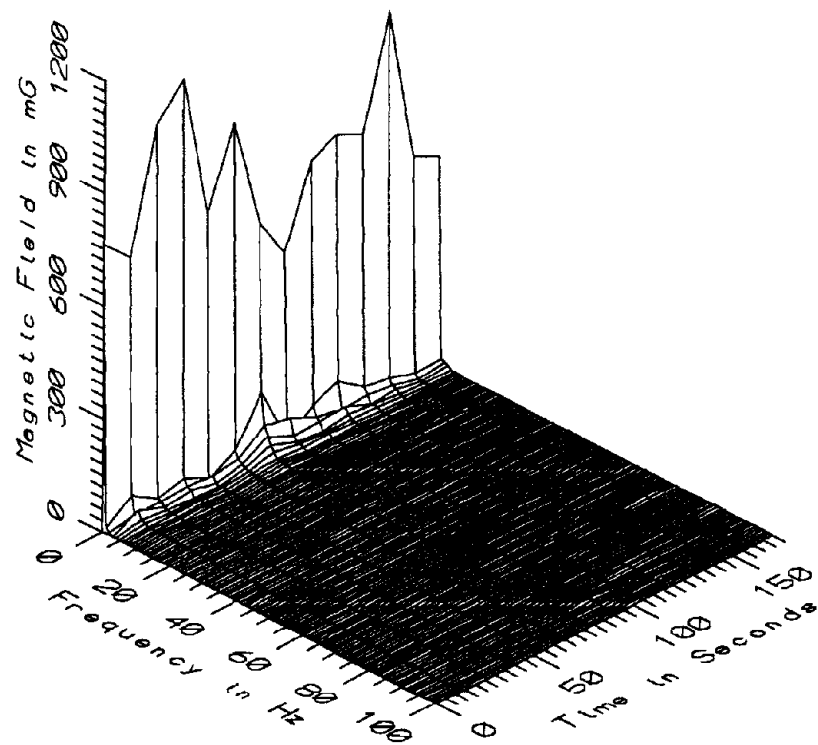

MET002 - REFERENCE PROBE - WINDOW SEAT AT REAR OF CAR 1173

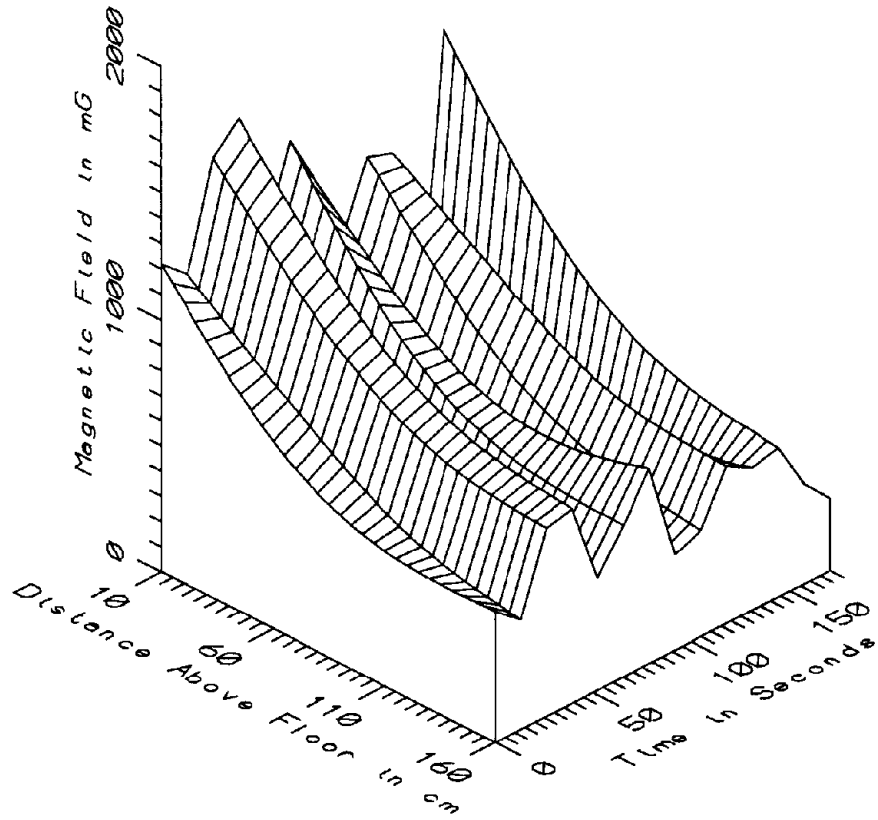

MET002 - CENTER OF AISLE, REAR OF CAR 1173 - STATIC

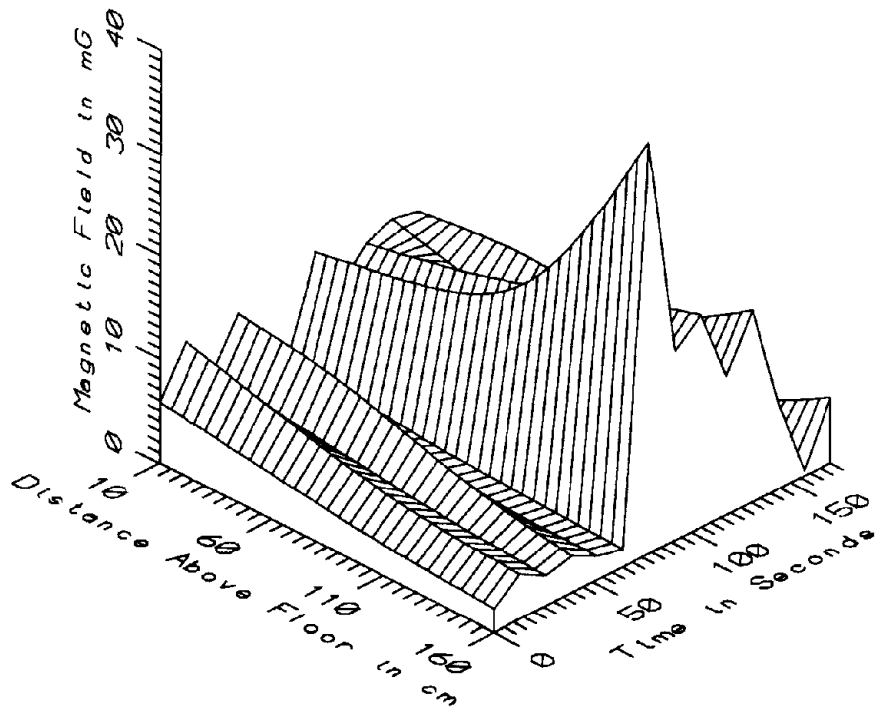

MET002 - CENTER OF AISLE, REAR OF CAR 1173 - LOW FREQ, 5-45Hz

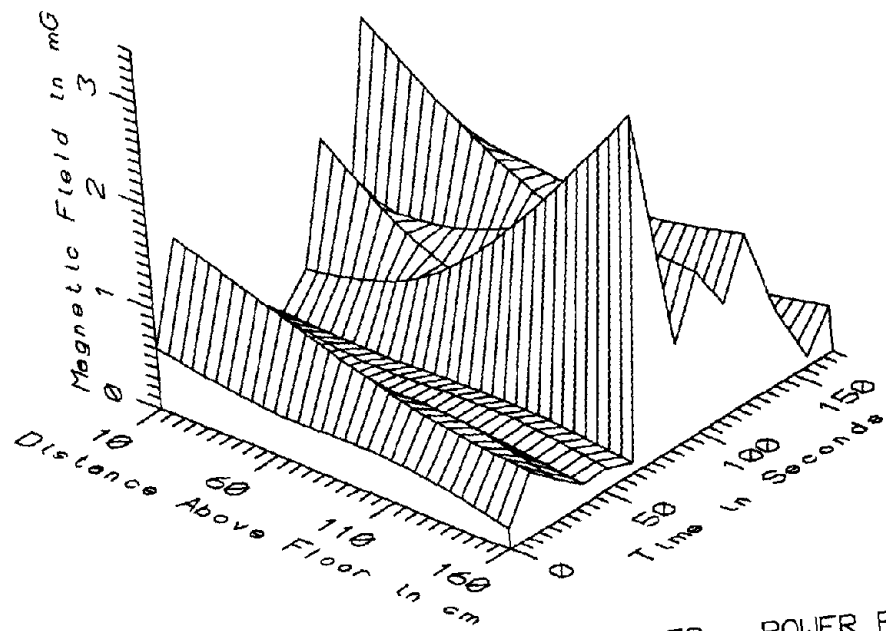

MET002 - CENTER OF AISLE, REAR OF CAR 1173 - POWER FREQ. 50-60Hz

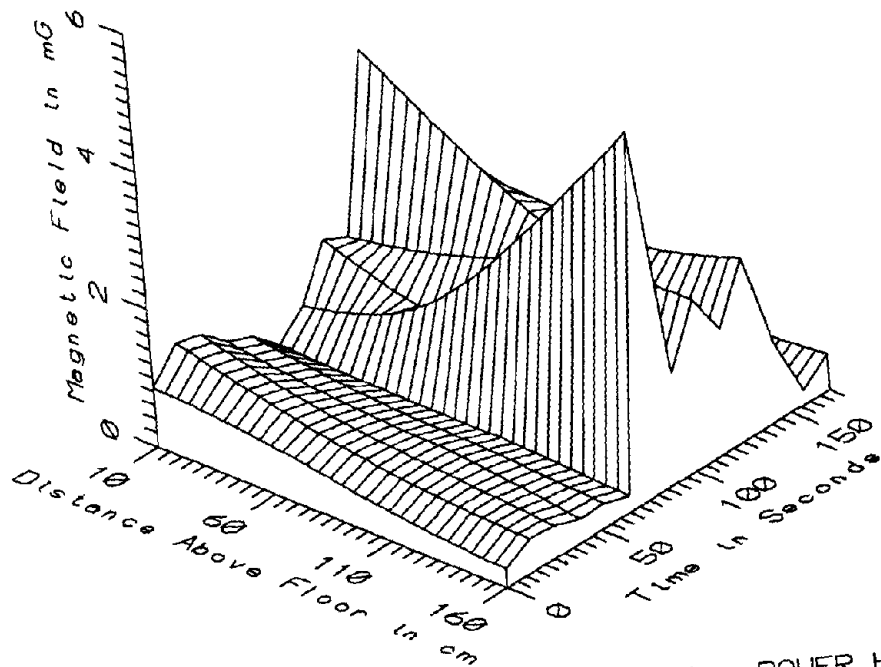

MET002 - CENTER OF AISLE, REAR OF CAR 1173 - POWER HARM, 65-300Hz



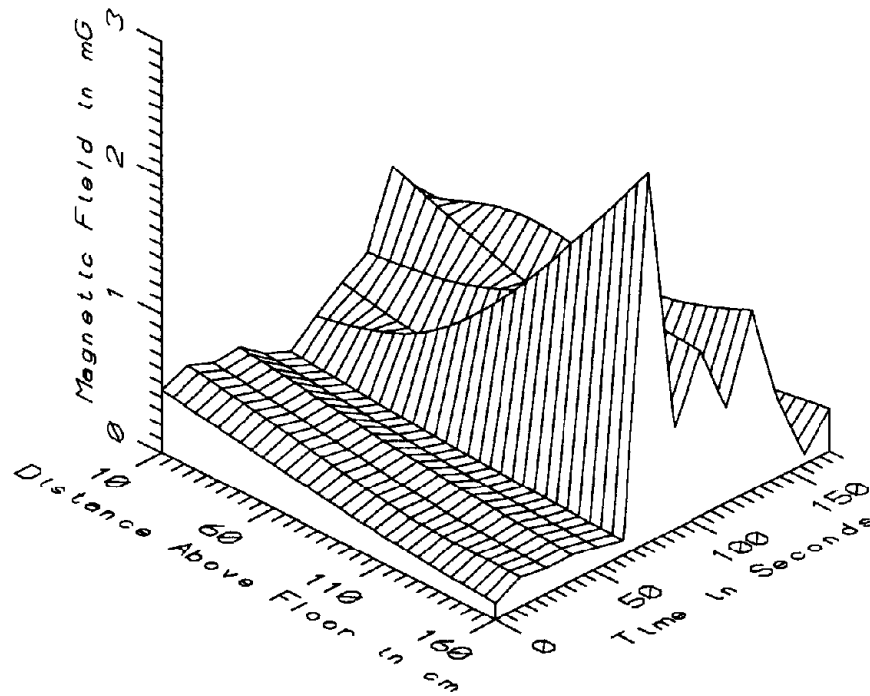

MET002 - CENTER OF AISLE, REAR OF CAR 1173 - HIGH FREQ, 305-2560Hz

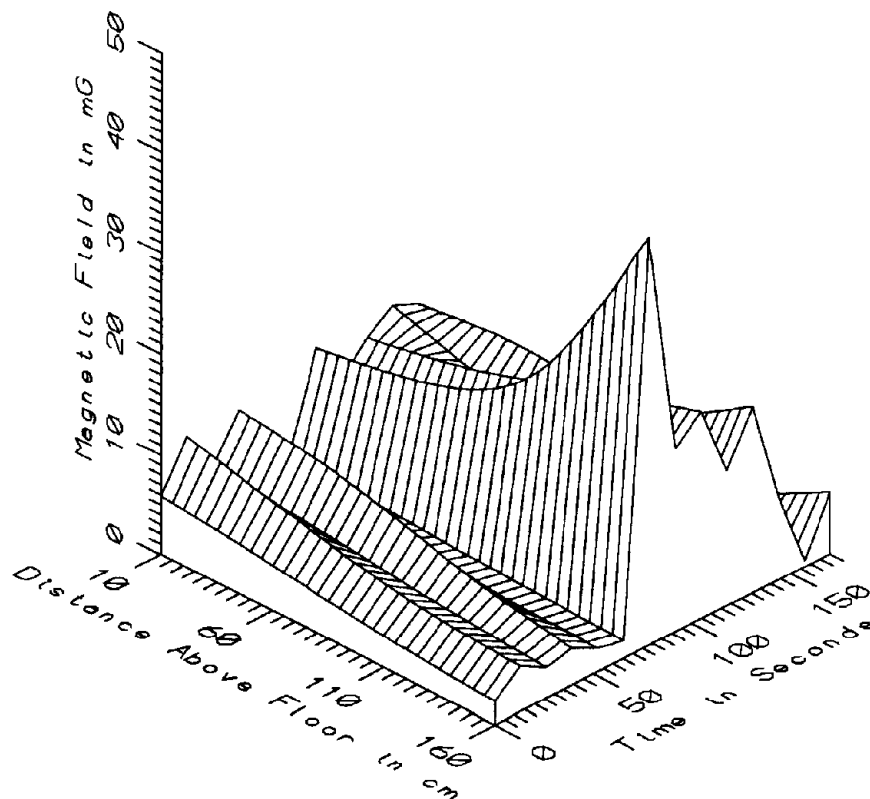

MET002 - CENTER OF AISLE, REAR OF CAR 1173 - ALL FREQ, 5-2560Hz

MET002 - CENTER OF AISLE, REAR OF CAR #1173				TOTAL OF 14 SAMPLES			
FREQUENCY BAND	HEIGHT ABOVE FLOOR (cm)	MINIMUM MAGNETIC FIELD (mG)	MAXIMUM MAGNETIC FIELD (mG)	AVERAGE MAGNETIC FIELD (mG)	STANDARD DEVIATION (mG)	COEFFICIENT OF VARIATION (%)	
STATIC	10	428.08	1637.63	1147.56	371.76	32.40	
	60	263.70	1133.03	762.76	241.95	31.72	
	110	339.92	846.04	565.79	160.71	28.41	
	160	286.04	765.78	533.94	152.66	28.59	
5-45Hz LOW FREQ	10	1.22	12.82	7.50	4.05	53.94	
	60	0.78	14.92	6.73	4.67	69.45	
	110	0.64	21.33	7.12	6.33	88.89	
	160	0.60	39.95	10.19	11.01	108.02	
50-60Hz PWR FREQ	10	0.21	2.50	0.88	0.68	78.08	
	60	0.14	1.68	0.67	0.51	76.83	
	110	0.21	1.92	0.74	0.55	74.72	
	160	0.10	3.34	0.82	0.88	108.43	
65-300Hz PWR HARM	10	0.31	3.81	1.12	0.89	79.99	
	60	0.29	2.75	0.99	0.76	77.18	
	110	0.23	3.09	1.06	0.92	86.99	
	160	0.22	5.29	1.25	1.42	113.15	
305-2560Hz HIGH FREQ	10	0.16	1.22	0.51	0.28	53.97	
	60	0.11	1.16	0.47	0.31	67.11	
	110	0.08	1.55	0.49	0.46	93.11	
	160	0.08	2.68	0.61	0.72	117.74	
5-2560Hz ALL FREQ	10	1.30	13.09	7.69	4.14	53.87	
	60	0.91	15.02	6.87	4.73	68.92	
	110	0.75	21.69	7.26	6.42	88.39	
	160	0.65	40.53	10.32	11.15	108.03	

APPENDIX D

DATASET MET003  
IN FRONT OF OPERATOR'S SEAT, CAR #1173

Measurement Setup Code:        Staff:     8     Reference: 10,11  
   Drawing:  A-1

Vehicle Status:                    Traveling on the Red Line

Measurement Date:                May 19, 1992

Measurement Time:                Start:     08:35:36  
   End:        08:39:42

Number of Samples:                27

Programmed Sample Interval:     5 sec

Actual Sample Interval:         9.5 sec

Frequency Spectrum Parameters

<u>Probe Type:</u>	<u>Wideband</u>	<u>Static</u>
Maximum Frequency (Hz)	2560	100
Minimum Frequency (Hz)	5	0
Spectral Bandwidth (Hz)	5	1

Missing Data: Wideband data from the reference probe

Saturated Data - Wideband:	<u>Sensor</u>	<u>Sample</u>	<u>Time (sec)</u>
	10cm	26	238
	110cm	25	228
	160cm	26	238

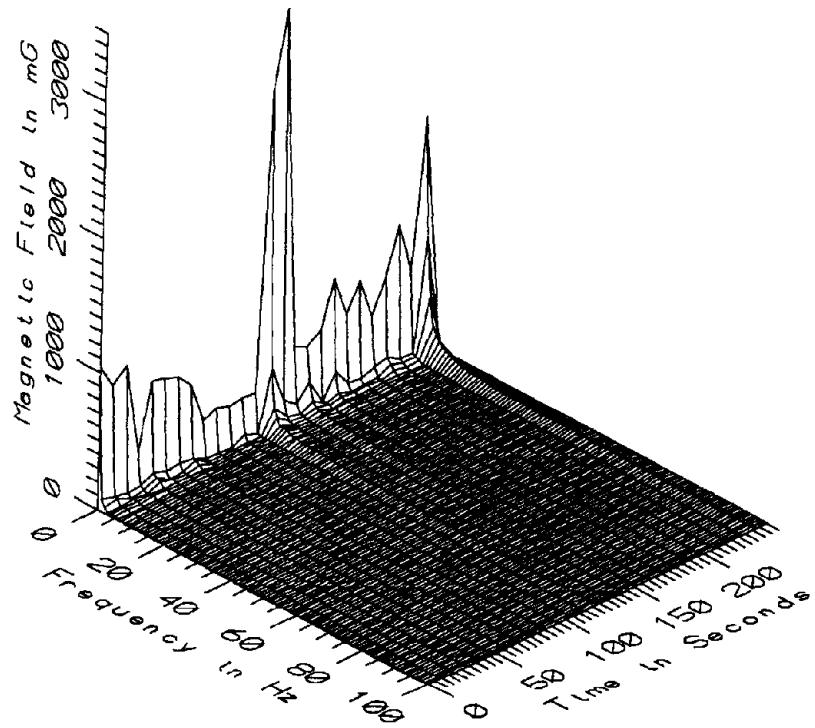

MET003 - 10cm ABOVE FLOOR, IN FRONT OF OPERATOR'S SEAT, CAR 1173

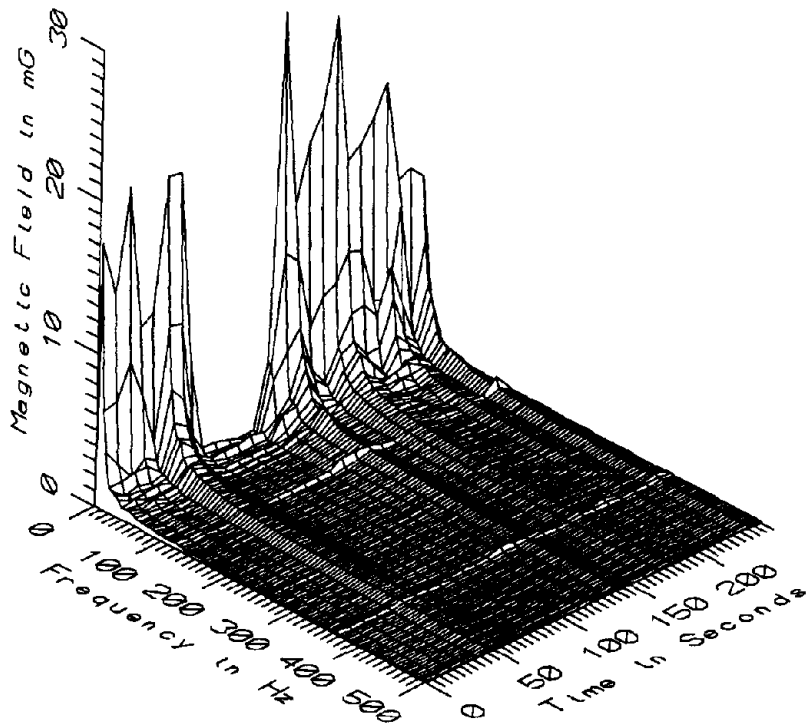

MET003 - 10cm ABOVE FLOOR, IN FRONT OF OPERATOR'S SEAT, CAR 1173

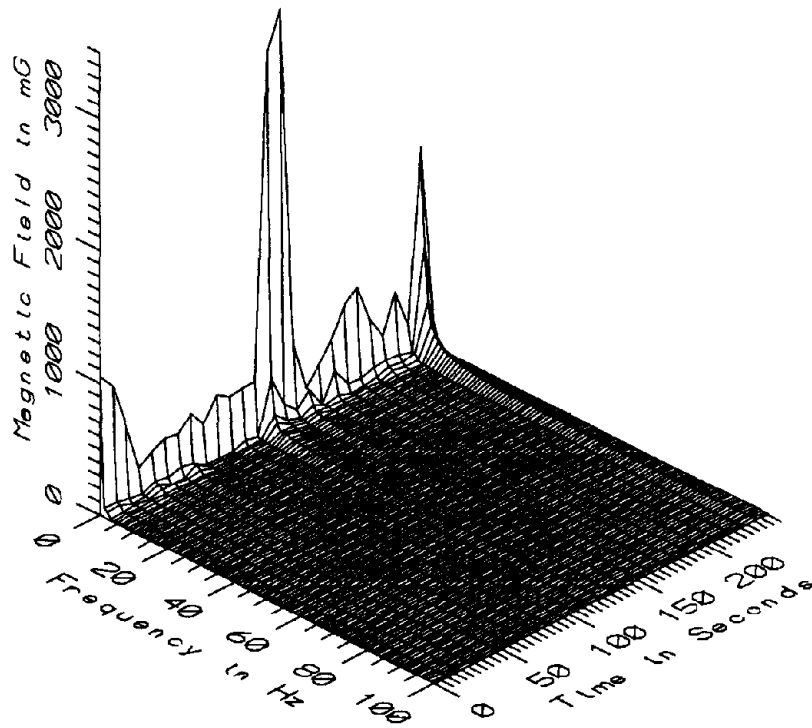

MET003 - 60cm ABOVE FLOOR, IN FRONT OF OPERATOR'S SEAT, CAR 1173

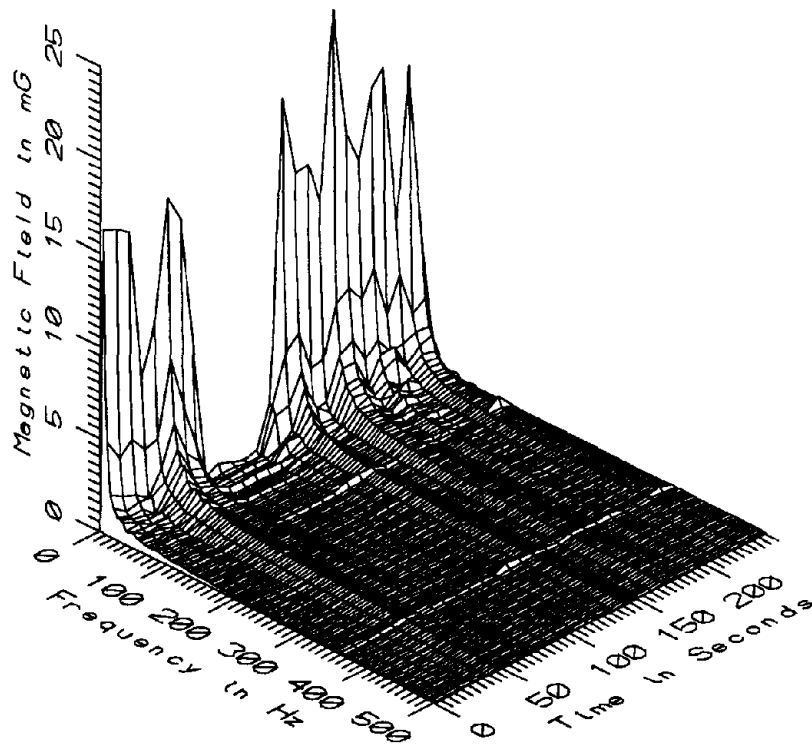

MET003 - 60cm ABOVE FLOOR, IN FRONT OF OPERATOR'S SEAT, CAR 1173

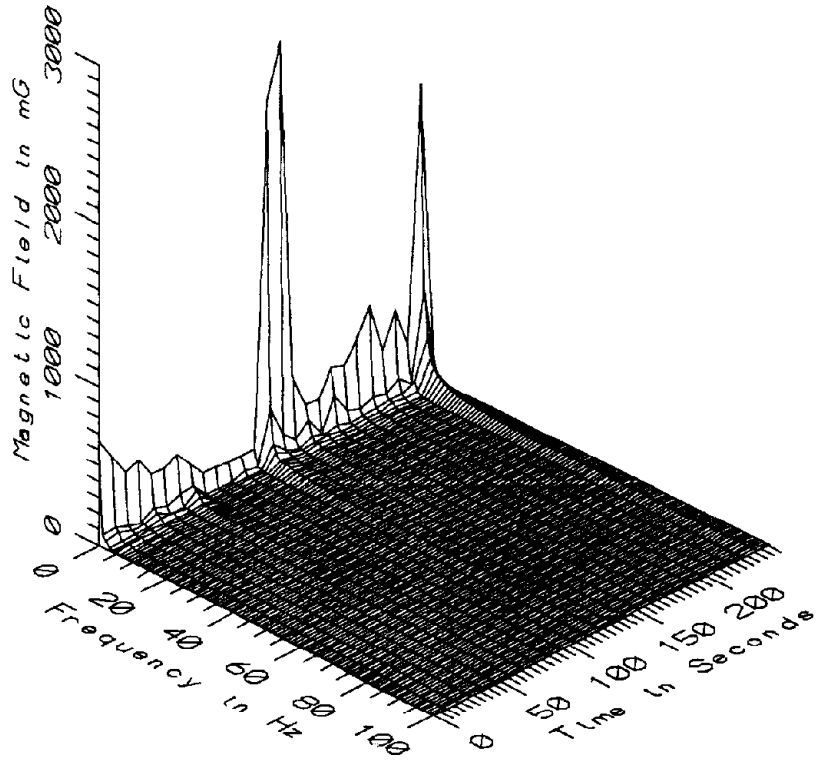

MET003 - 110cm ABOVE FLOOR, IN FRONT OF OPERATOR'S SEAT, CAR 1173

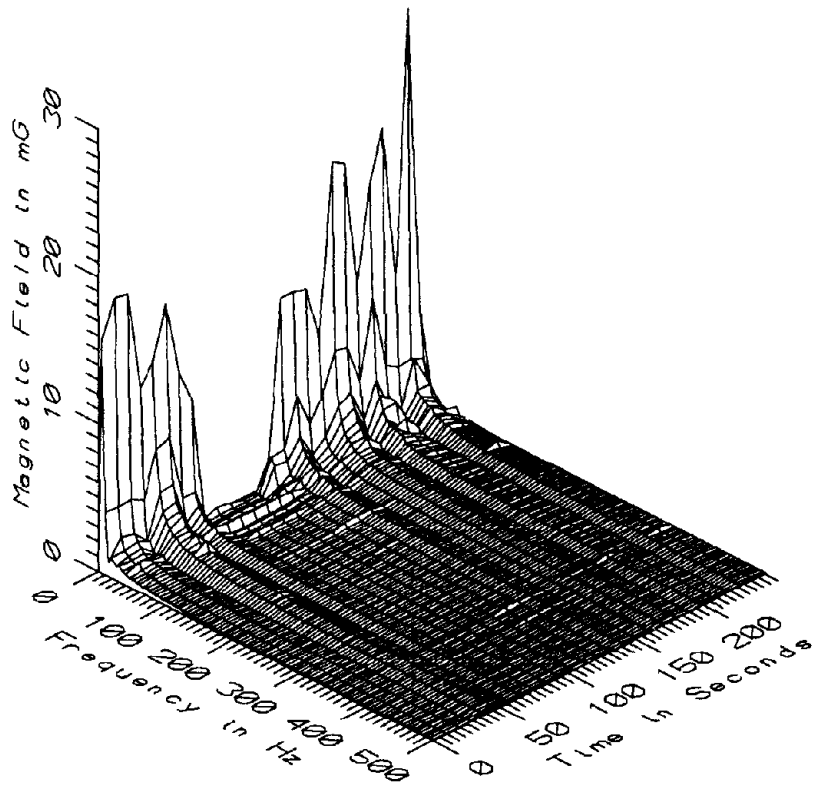

MET003 - 110cm ABOVE FLOOR, IN FRONT OF OPERATOR'S SEAT, CAR 1173

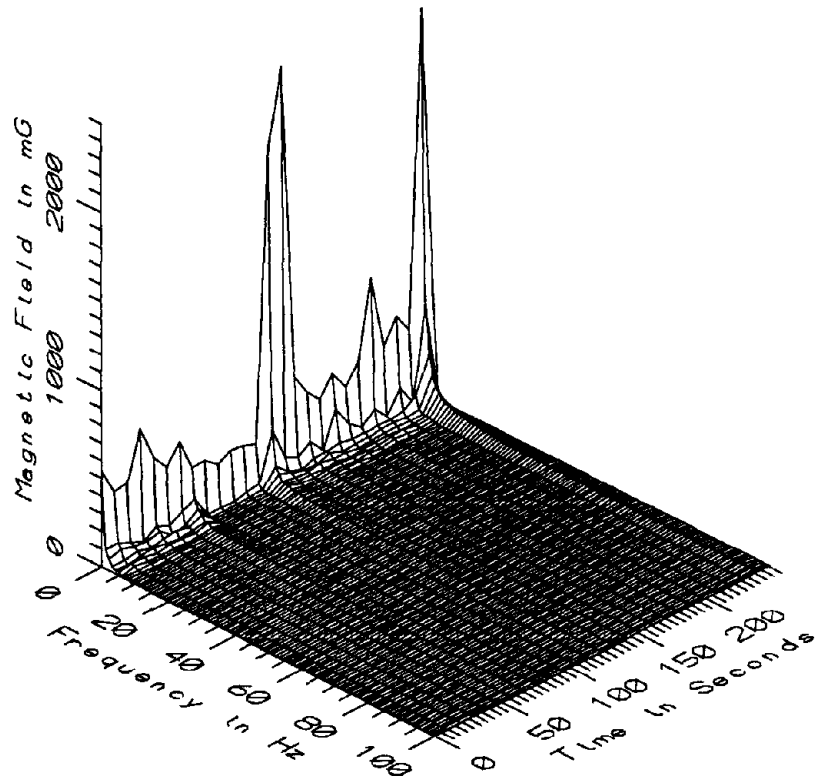

MET003 - 160cm ABOVE FLOOR, IN FRONT OF OPERATOR'S SEAT, CAR 1173

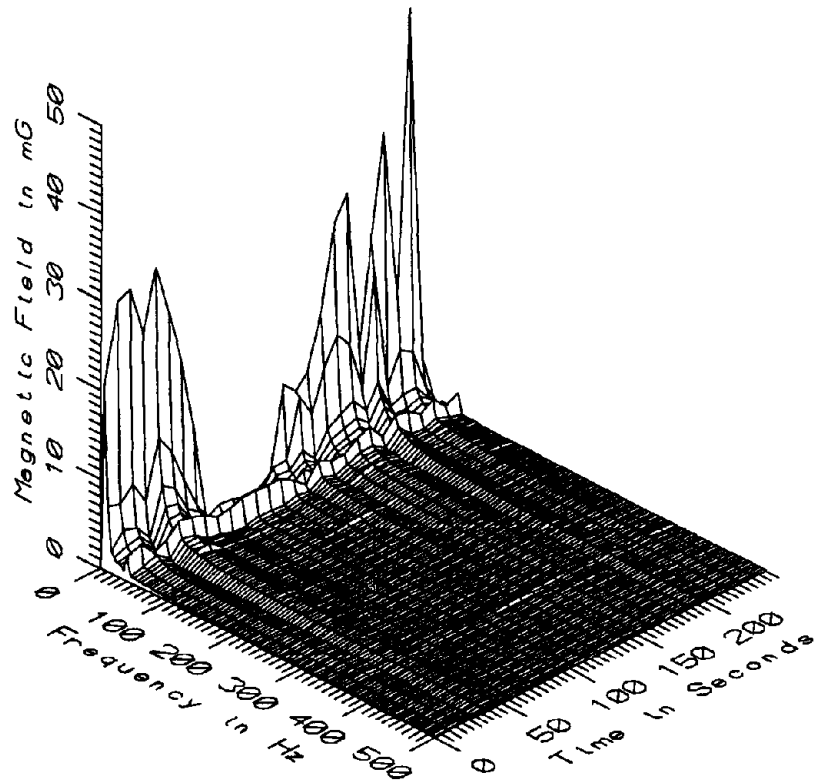

MET003 - 160cm ABOVE FLOOR, IN FRONT OF OPERATOR'S SEAT, CAR 1173

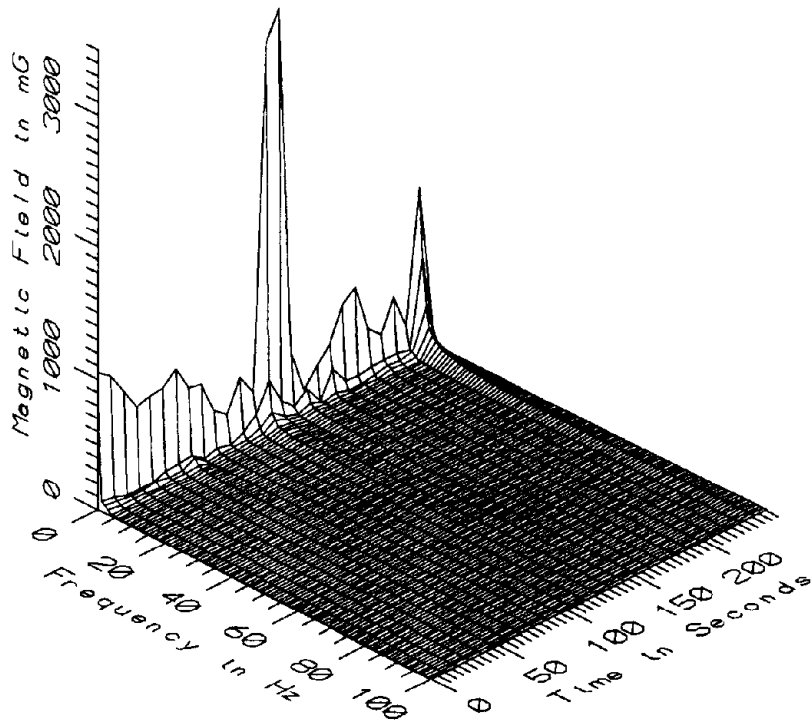

MET003 - REFERENCE PROBE - WINDOW SEAT AT REAR OF CAR 1173



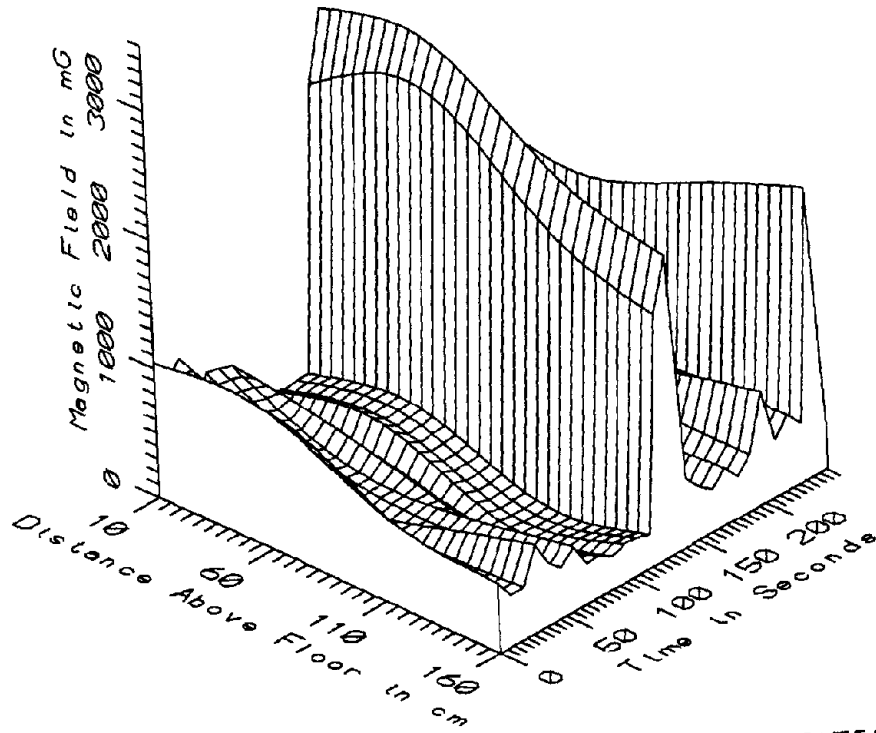

MET003 - IN FRONT OF OPERATOR'S SEAT, CAR 1173 - STATIC

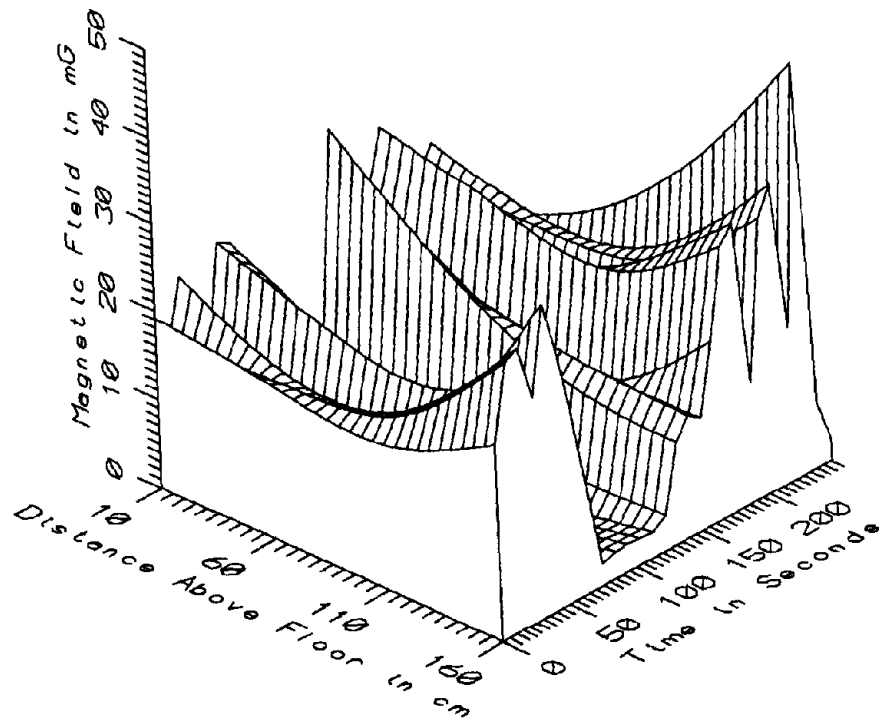

MET003 - IN FRONT OF OPERATOR'S SEAT, CAR 1173 - LOW FREQ, 5-45Hz

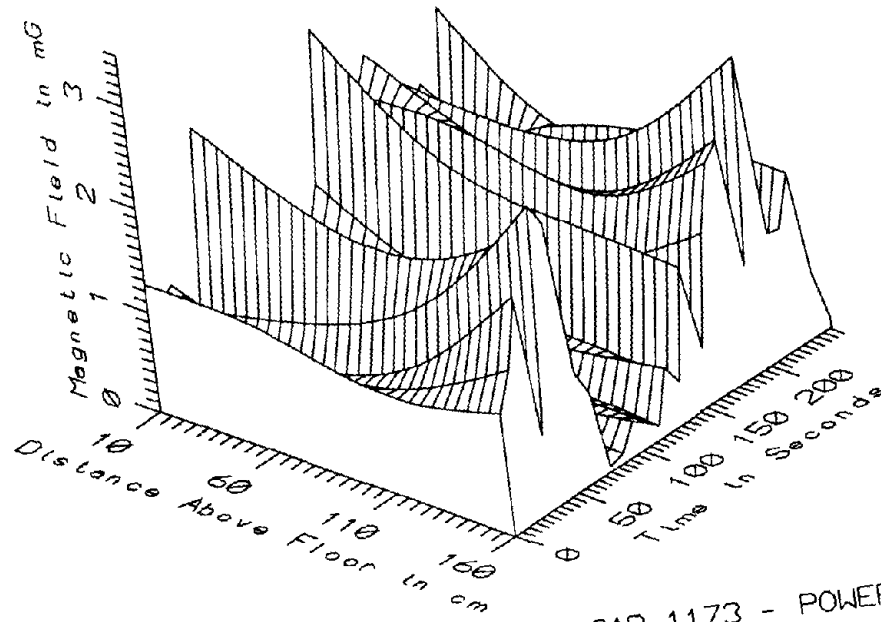

MET003 - IN FRONT OF OPERATOR'S SEAT, CAR 1173 - POWER FREQ, 50-60Hz

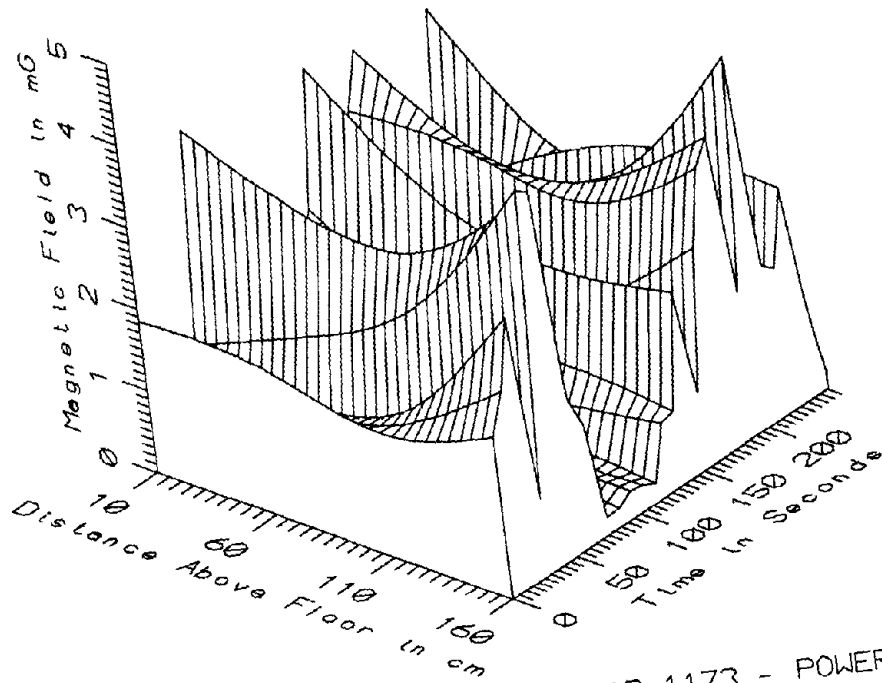

MET003 - IN FRONT OF OPERATOR'S SEAT, CAR 1173 - POWER HARM, 65-300Hz

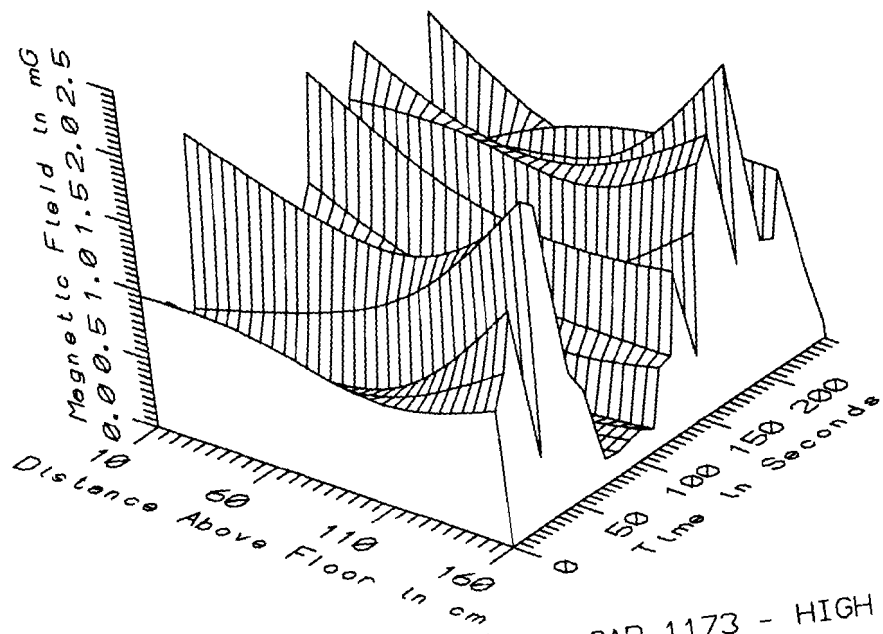

MET003 - IN FRONT OF OPERATOR'S SEAT, CAR 1173 - HIGH FREQ, 305-2560Hz

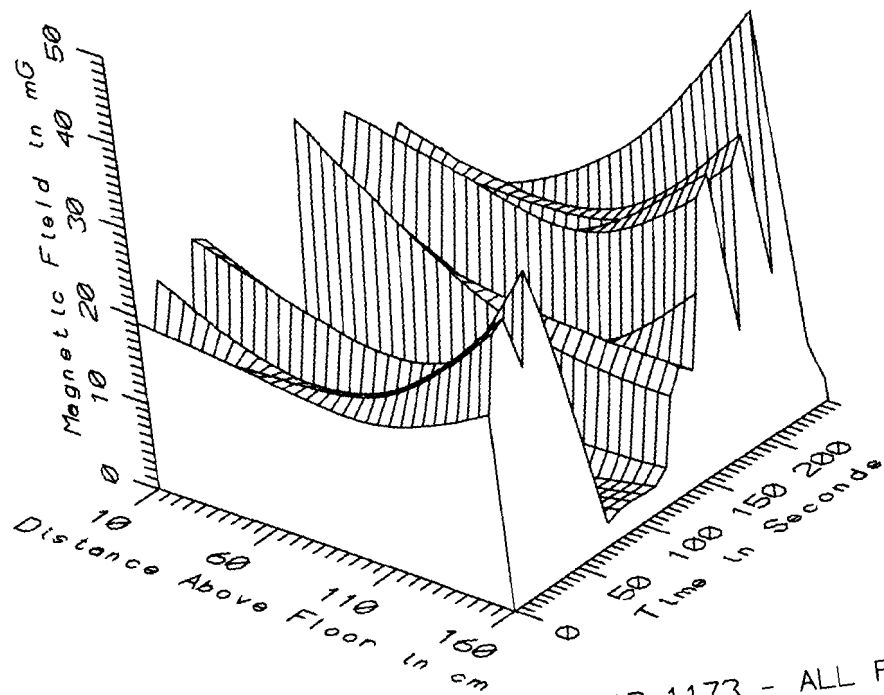

MET003 - IN FRONT OF OPERATOR'S SEAT, CAR 1173 - ALL FREQ, 5-2560Hz

MET003 - IN FRONT OF OPERATORS SEAT, CAR #1173		TOTAL OF 27 SAMPLES				
FREQUENCY BAND	HEIGHT ABOVE FLOOR (cm)	MINIMUM MAGNETIC FIELD (mG)	MAXIMUM MAGNETIC FIELD (mG)	AVERAGE MAGNETIC FIELD (mG)	STANDARD DEVIATION (mG)	COEFFICIENT OF VARIATION (%)
STATIC	10	274.28	3042.39	805.31	655.14	81.35
	60	169.70	3148.44	680.01	734.84	108.06
	110	114.25	2582.07	540.46	637.31	117.92
	160	249.88	2310.96	616.54	571.48	92.69
5-45Hz	10	0.62	29.66	14.33	8.90	62.13
LOW FREQ	60	0.45	23.60	11.78	7.32	62.19
	110	0.69	28.68	12.07	8.02	66.46
	160	2.44	46.79	18.53	12.88	69.52
50-60Hz	10	0.19	2.58	1.06	0.71	67.36
PWR FREQ	60	0.06	1.90	0.82	0.55	67.58
	110	0.17	1.93	0.87	0.57	66.32
	160	0.06	3.05	1.21	0.90	74.91
65-300Hz	10	0.16	3.68	1.55	1.09	70.12
PWR HARM	60	0.19	3.16	1.30	0.86	66.22
	110	0.16	3.22	1.32	0.94	71.32
	160	0.21	4.59	1.88	1.40	74.34
305-2560Hz	10	0.12	1.87	0.82	0.53	64.63
HIGH FREQ	60	0.11	1.57	0.69	0.42	61.05
	110	0.09	1.55	0.67	0.48	71.61
	160	0.12	2.32	0.98	0.69	70.54
5-2560Hz	10	0.74	29.76	14.51	8.96	61.75
ALL FREQ	60	0.53	23.85	11.92	7.37	61.85
	110	0.76	28.87	12.21	8.07	66.08
	160	2.46	46.91	18.71	12.97	69.36

APPENDIX E

DATASET MET004  
CENTER OF AISLE, CENTER OF CAR #3012

Measurement Setup Code:      Staff:    1      Reference: -  
   Drawing: A-1

Vehicle Status:                    Traveling on the Red Line

Measurement Date:                May 19, 1992

Measurement Time:                Start:    09:59:55  
   End:      10:00:08

Number of Samples:                2

Programmed Sample Interval:      5 sec

Actual Sample Interval:          13.0 sec

Frequency Spectrum Parameters

<u>Probe Type:</u>	<u>Wideband</u>	<u>Static</u>
Maximum Frequency (Hz)	2560	100
Minimum Frequency (Hz)	5	0
Spectral Bandwidth (Hz)	5	1

Missing Data: No reference probe

Saturated Data - Wideband:	<u>Sensor</u>	<u>Sample</u>	<u>Time (sec)</u>
	10cm	1	0
	10cm	2	13
	60cm	2	13

Saturated Data - Static:	<u>Sensor</u>	<u>Sample</u>	<u>Time (sec)</u>
	10cm	1	0
	10cm	2	13
	60cm	1	0
	60cm	2	13
	110cm	1	0

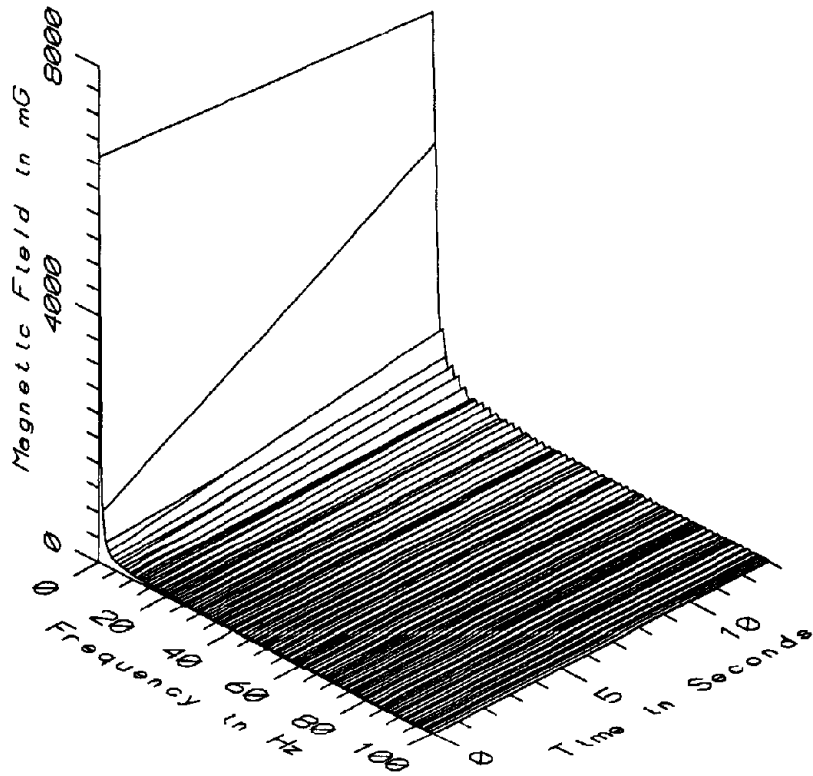

MET004 - 10cm ABOVE FLOOR, CENTER OF AISLE, CENTER OF CAR 3012

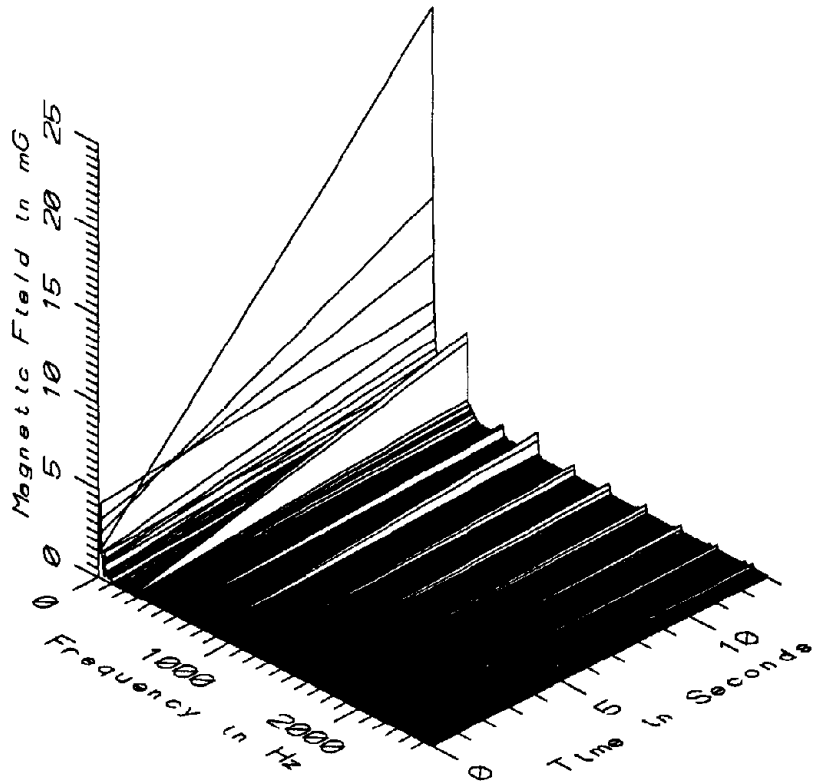

MET004 - 10cm ABOVE FLOOR, CENTER OF AISLE, CENTER OF CAR 3012

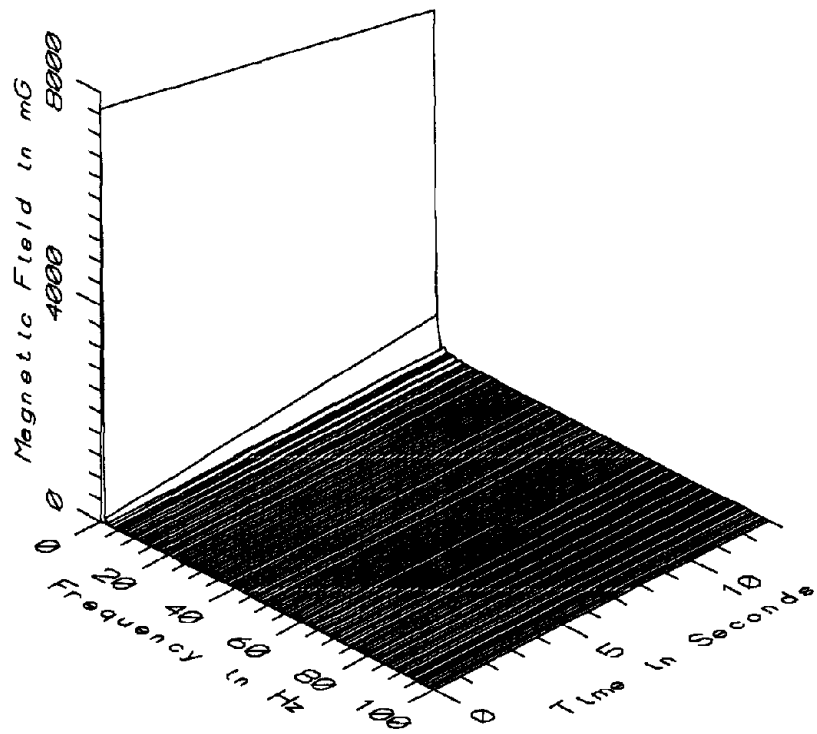

MET004 - 60cm ABOVE FLOOR, CENTER OF AISLE, CENTER OF CAR 3012

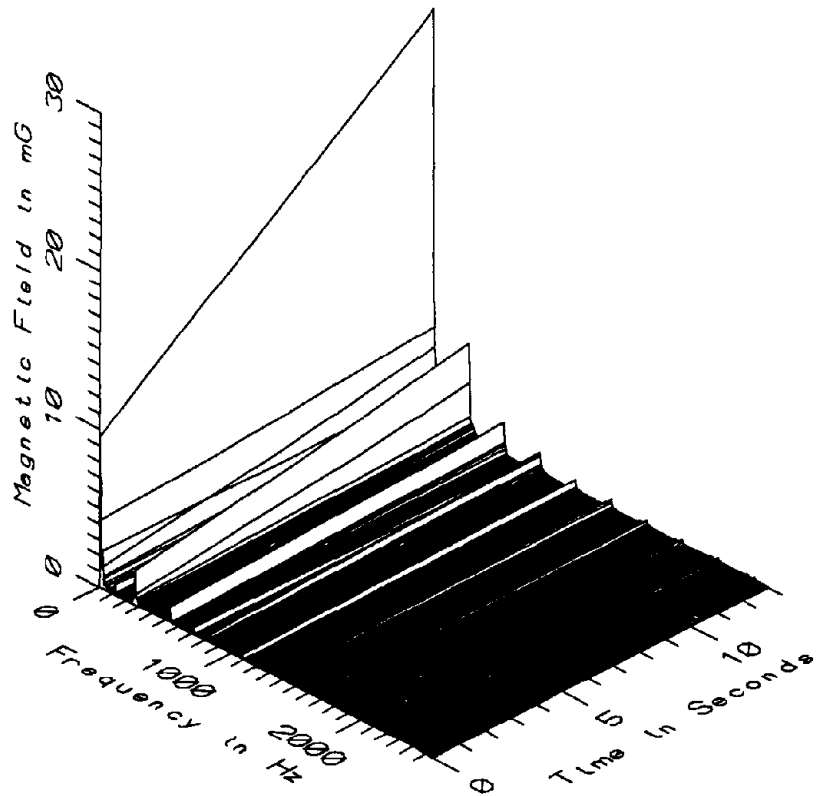

MET004 - 60cm ABOVE FLOOR, CENTER OF AISLE, CENTER OF CAR 3012

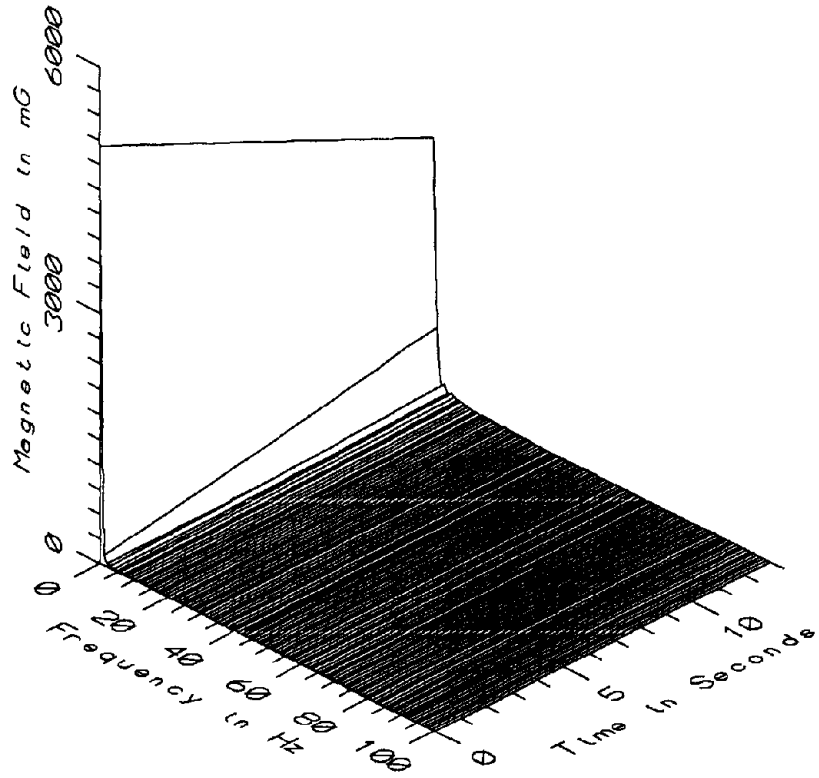

MET004 - 110cm ABOVE FLOOR, CENTER OF AISLE, CENTER OF CAR 3012

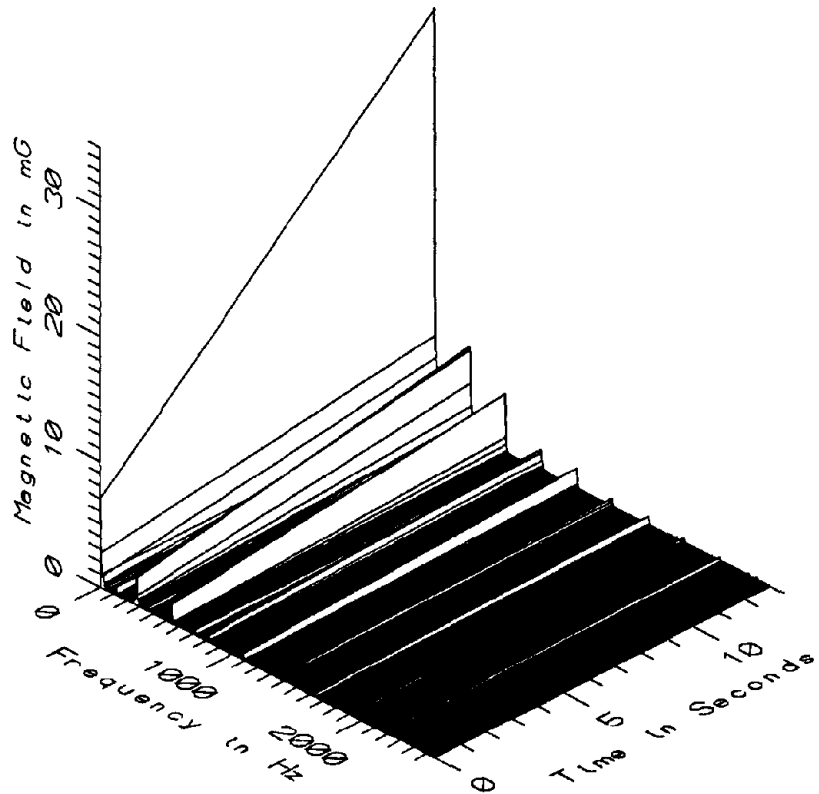

MET004 - 110cm ABOVE FLOOR, CENTER OF AISLE, CENTER OF CAR 3012



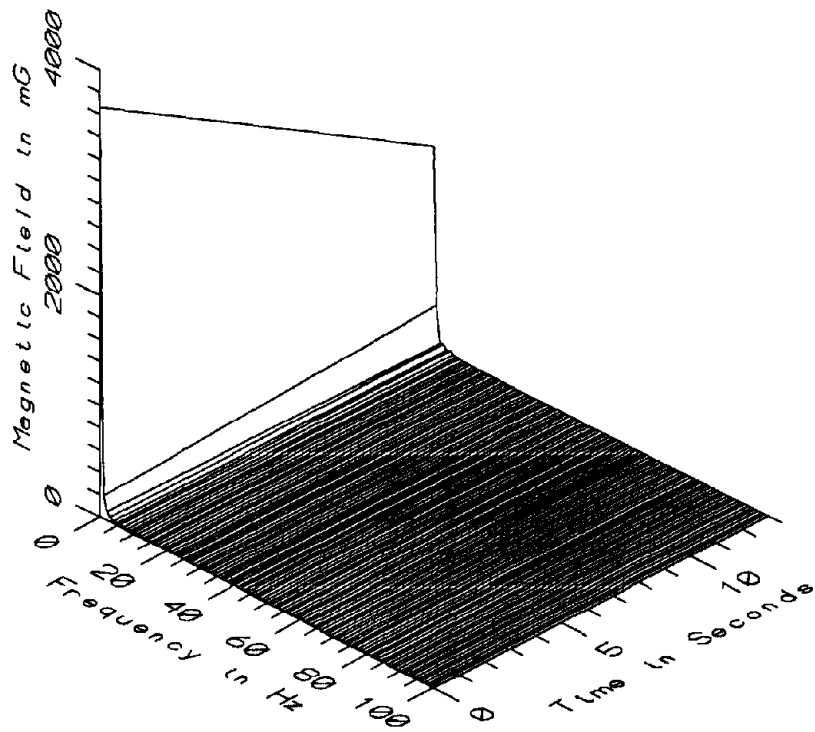

MET004 - 160cm ABOVE FLOOR, CENTER OF AISLE, CENTER OF CAR 3012

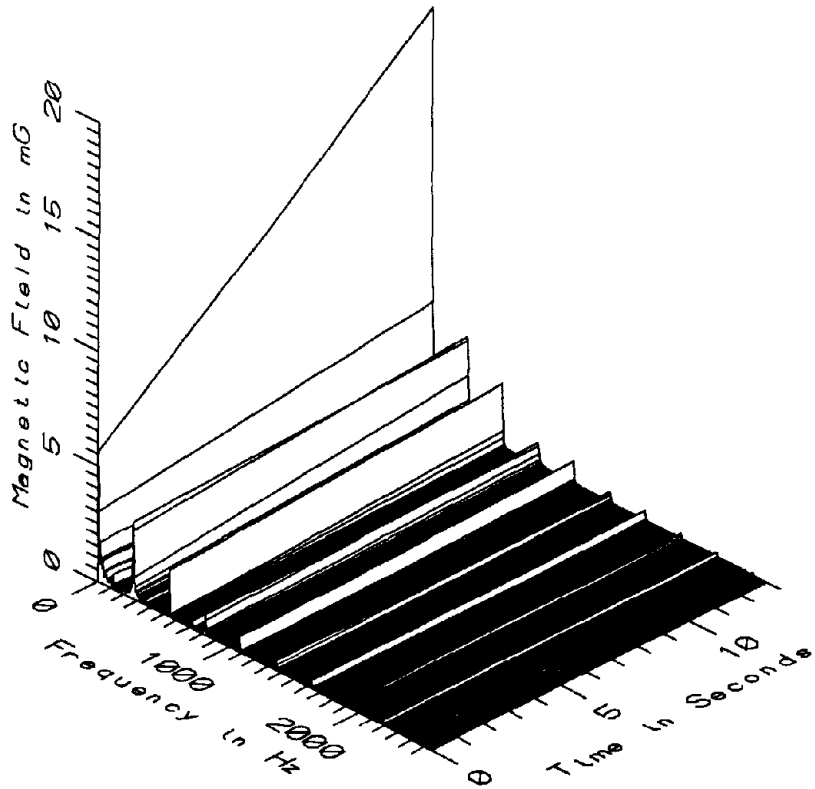

MET004 - 160cm ABOVE FLOOR, CENTER OF AISLE, CENTER OF CAR 3012

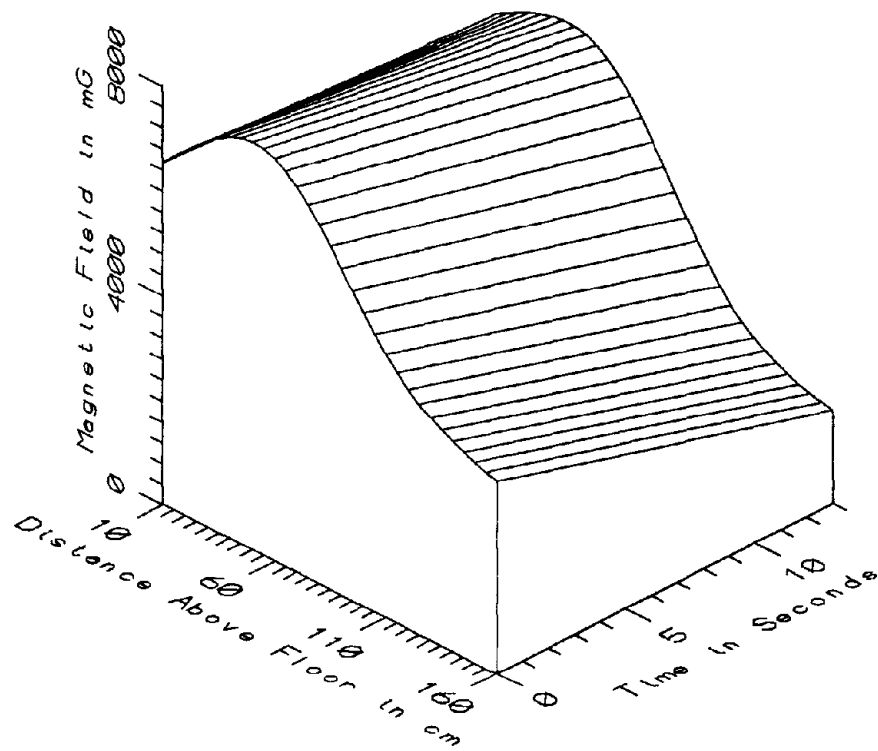

MET004 - CENTER OF AISLE, CENTER OF CAR 3012 - STATIC

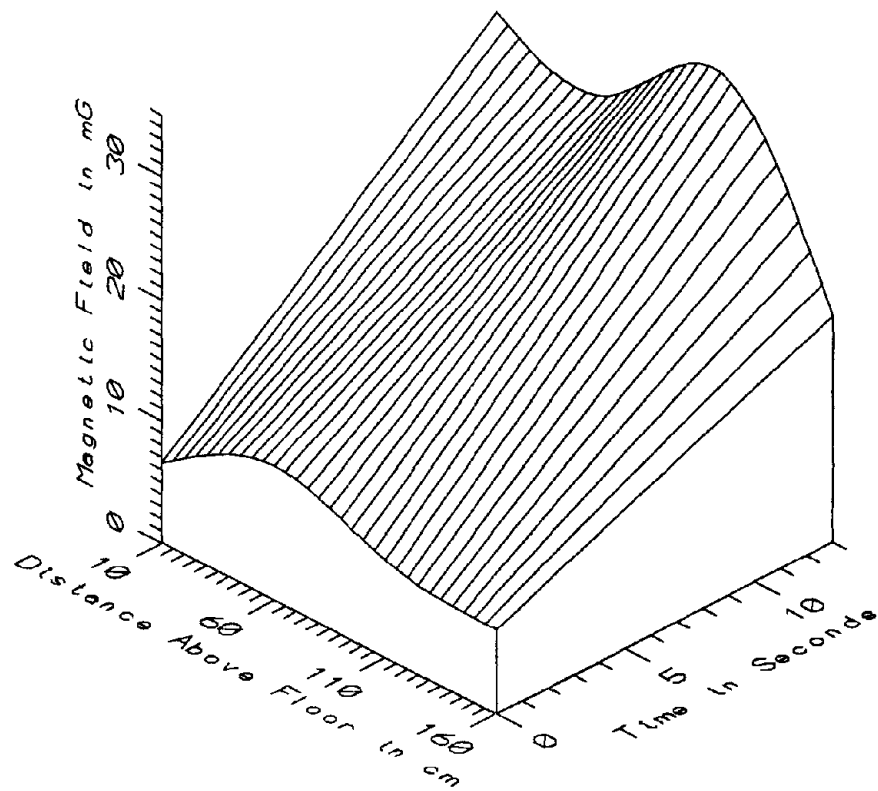

MET004 - CENTER OF AISLE, CENTER OF CAR 3012 - LOW FREQ, 5-45Hz

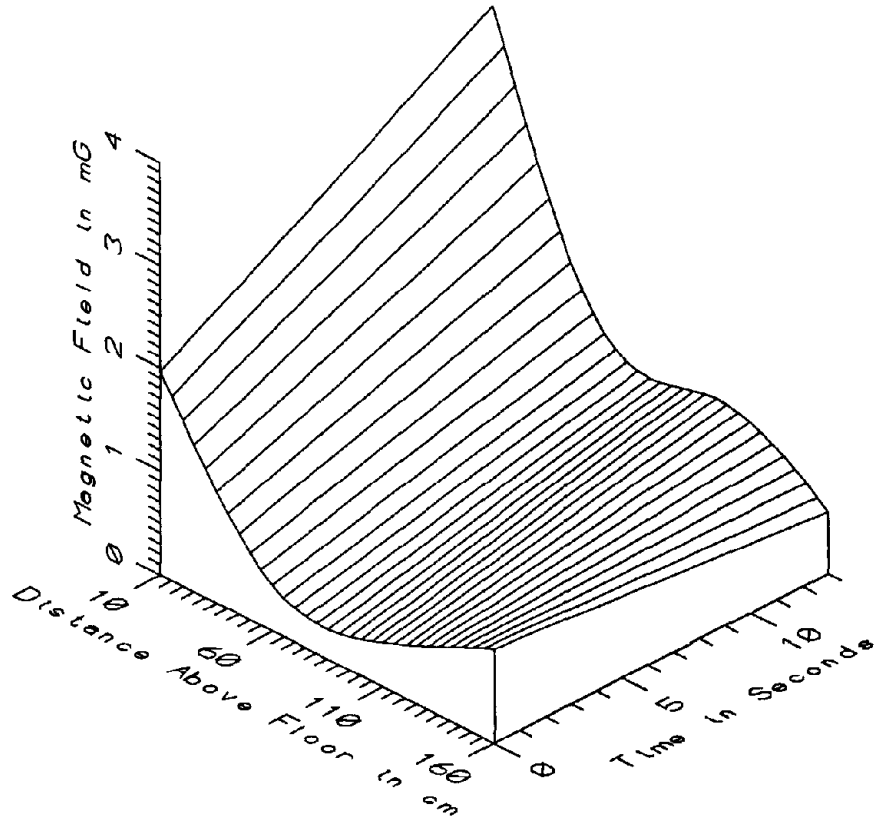

MET004 - CENTER OF AISLE, CENTER OF CAR 3012 - POWER FREQ, 50-60Hz

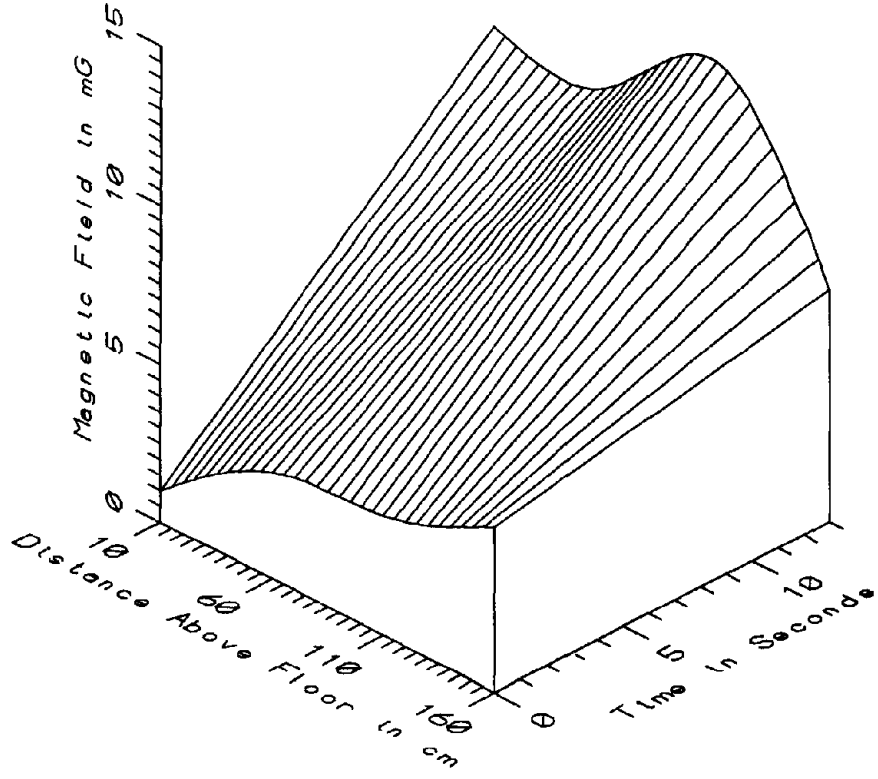

MET004 - CENTER OF AISLE, CENTER OF CAR 3012 - POWER HARM, 65-300Hz

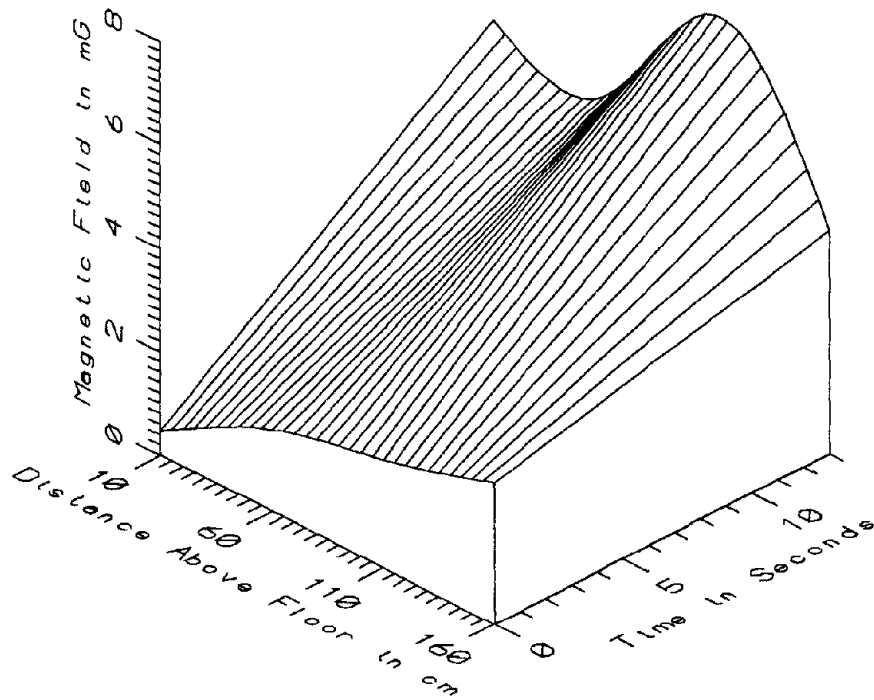

MET004 - CENTER OF AISLE, CENTER OF CAR 3012 - HIGH FREQ, 305-2560Hz

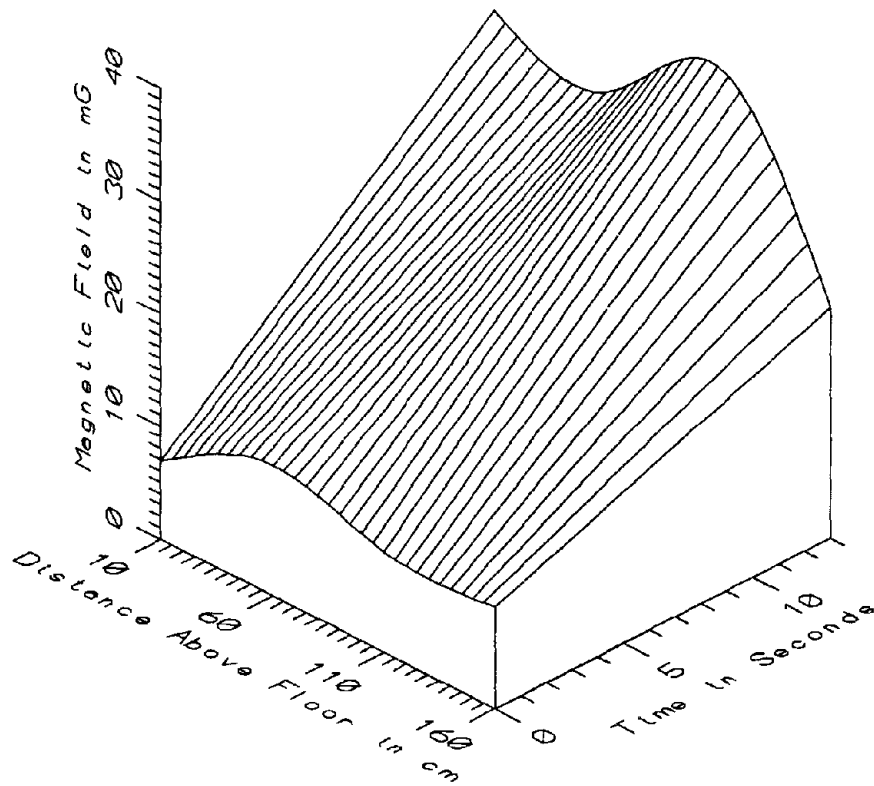

MET004 - CENTER OF AISLE, CENTER OF CAR 3012 - ALL FREQ, 5-2560Hz

MET004 - CENTER OF AISLE, CENTER OF CAR 3012		TOTAL OF 2 SAMPLES				
FREQUENCY BAND	HEIGHT ABOVE FLOOR (cm)	MINIMUM MAGNETIC FIELD (mG)	MAXIMUM MAGNETIC FIELD (mG)	AVERAGE MAGNETIC FIELD (mG)	STANDARD DEVIATION (mG)	COEFFICIENT OF VARIATION (%)
STATIC	10	49926.00	131469.00	90697.50	57659.61	63.57
	60	9012.00	23732.00	16372.00	10408.61	63.58
	110	3093.52	8038.00	5565.76	3496.28	62.82
	160	1803.03	3666.61	2734.82	1317.75	48.18
5-45Hz LOW FREQ	10	6.53	29.46	17.99	16.22	90.13
	60	10.94	27.26	19.10	11.54	60.42
	110	7.83	33.80	20.82	18.36	88.20
50-60Hz PWR FREQ	160	6.89	18.56	12.73	8.25	64.82
	10	1.97	3.86	2.91	1.34	45.93
	60	0.45	1.24	0.84	0.56	65.93
65-300Hz PWR HARM	110	0.43	1.14	0.79	0.50	64.23
	160	0.59	0.92	0.76	0.23	30.23
	10	1.01	10.32	5.66	6.58	116.27
	60	3.36	10.10	6.73	4.77	70.85
305-2560Hz HIGH FREQ	110	3.74	12.71	8.23	6.34	77.05
	160	5.17	7.32	6.24	1.52	24.38
	10	0.47	5.14	2.81	3.30	117.55
	60	1.59	4.75	3.17	2.24	70.64
5-2560Hz ALL FREQ	110	2.09	7.40	4.75	3.76	79.20
	160	2.73	4.32	3.52	1.12	31.88
	10	6.91	31.87	19.39	17.65	91.04
	60	11.56	29.48	20.52	12.67	61.75
110	110	8.94	36.88	22.91	19.75	86.22
	160	9.08	20.42	14.75	8.02	54.35



APPENDIX F

DATASET MET006  
CENTER OF AISLE, CENTER OF CAR #3012

Measurement Setup Code:        Staff:     1     Reference:   9  
   Drawing:  A-1

Vehicle Status:                Traveling on the Red Line

Measurement Date:              May 19, 1992

Measurement Time:              Start:     10:04:26  
   End:        10:05:24

Number of Samples:             10

Programmed Sample Interval:   5 sec

Actual Sample Interval:        6.4 sec

Frequency Spectrum Parameters

<u>Probe Type:</u>	<u>Wideband</u>	<u>Static</u>
Maximum Frequency (Hz)	2560	100
Minimum Frequency (Hz)	5	0
Spectral Bandwidth (Hz)	5	1

Missing Data: Wideband data from the reference probe

Saturated Data - Wideband:	<u>Sensor</u>	<u>Sample</u>	<u>Time (sec)</u>
	10cm	10	58
	60cm	10	58

Saturated Data - Static:	<u>Sensor</u>	<u>Sample</u>	<u>Time (sec)</u>
	10cm	2	13
	60cm	2	13

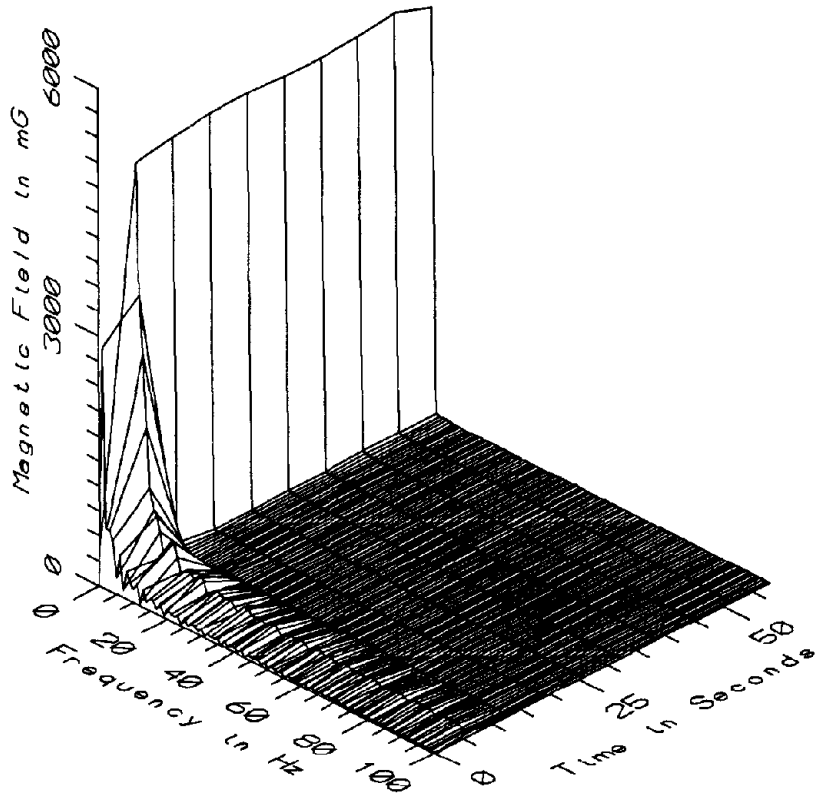

MET006 - 10cm ABOVE FLOOR, CENTER OF AISLE, CENTER OF CAR 3012

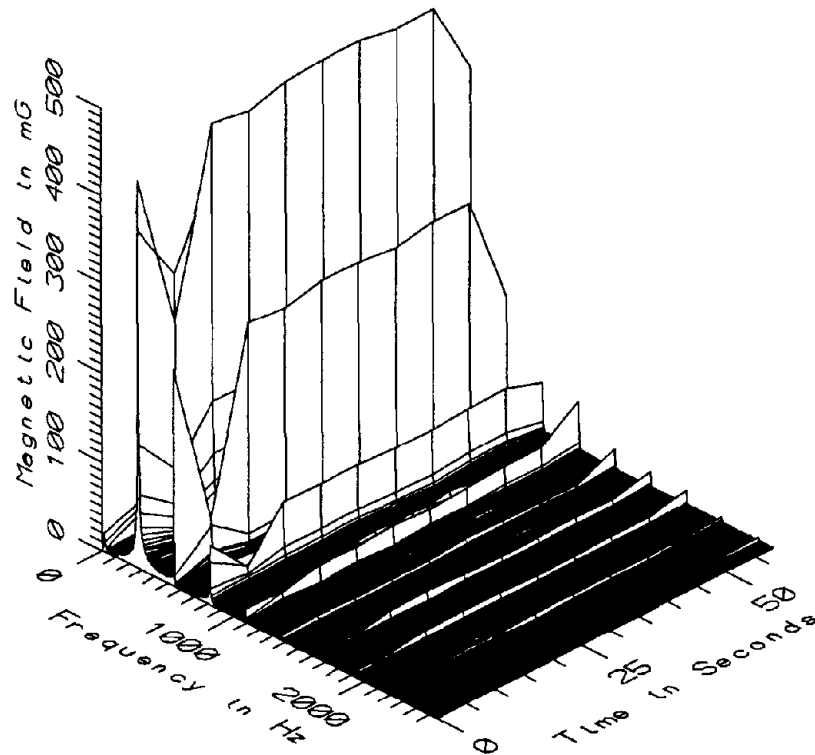

MET006 - 10cm ABOVE FLOOR, CENTER OF AISLE, CENTER OF CAR 3012



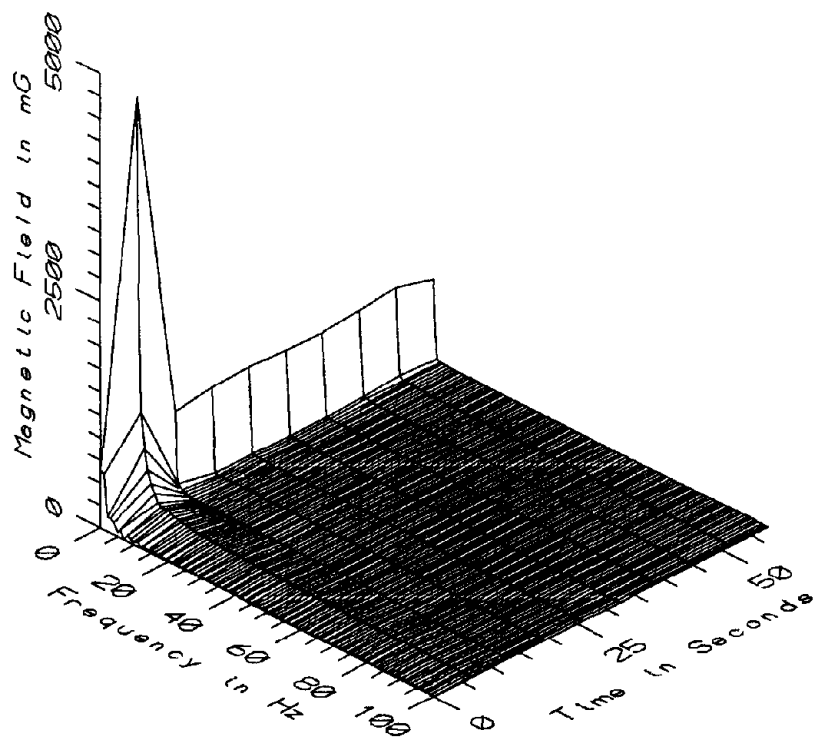

MET006 - 60cm ABOVE FLOOR, CENTER OF AISLE, CENTER OF CAR 3012

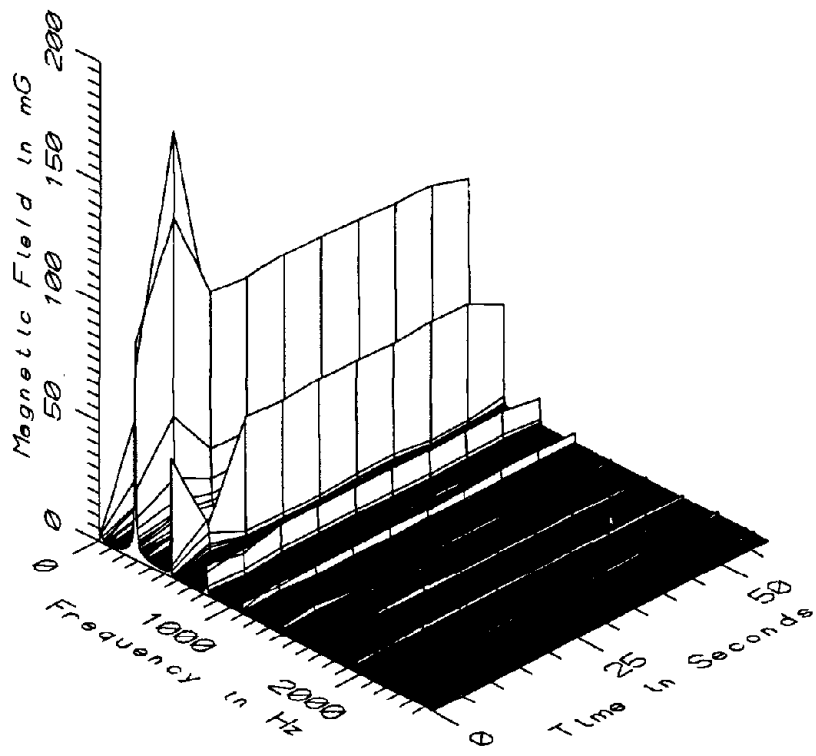

MET006 - 60cm ABOVE FLOOR, CENTER OF AISLE, CENTER OF CAR 3012

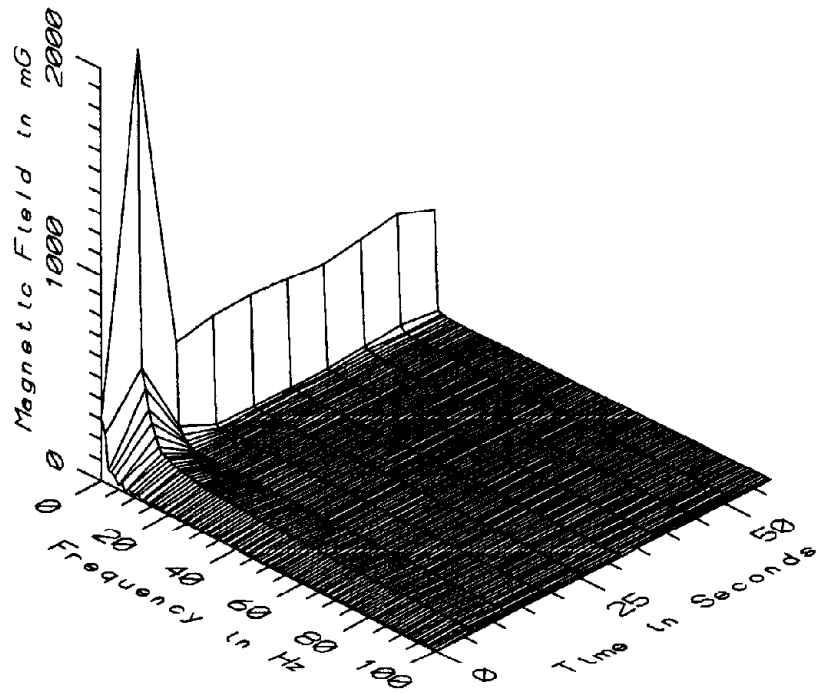

MET006 - 110cm ABOVE FLOOR, CENTER OF AISLE, CENTER OF CAR 3012

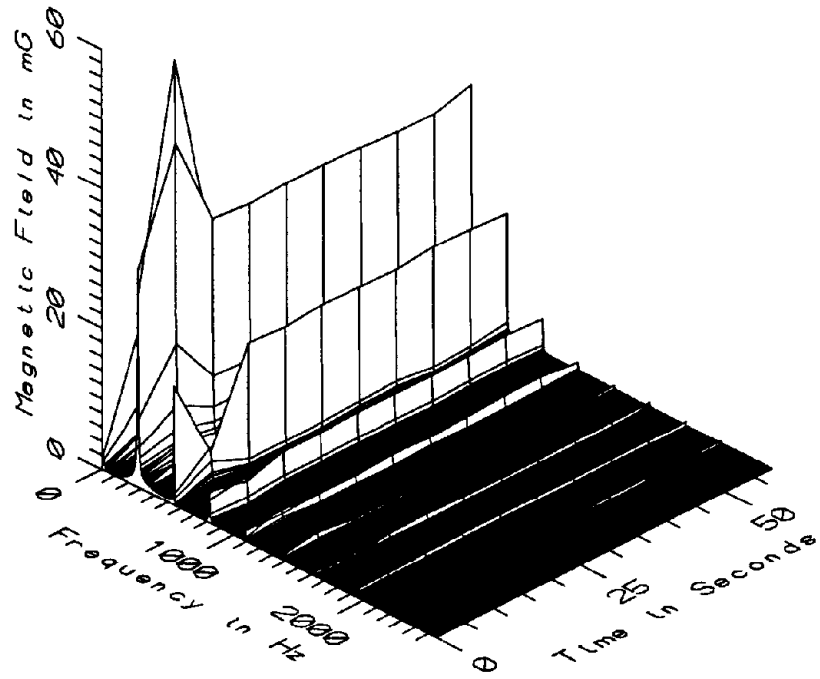

MET006 - 110cm ABOVE FLOOR, CENTER OF AISLE, CENTER OF CAR 3012

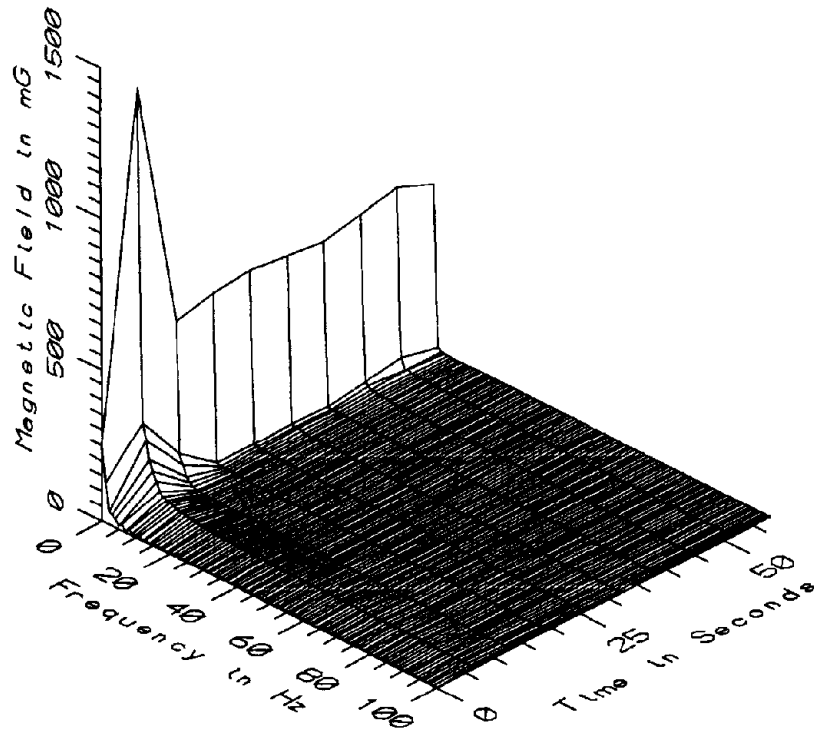

MET006 - 160cm ABOVE FLOOR, CENTER OF AISLE, CENTER OF CAR 3012

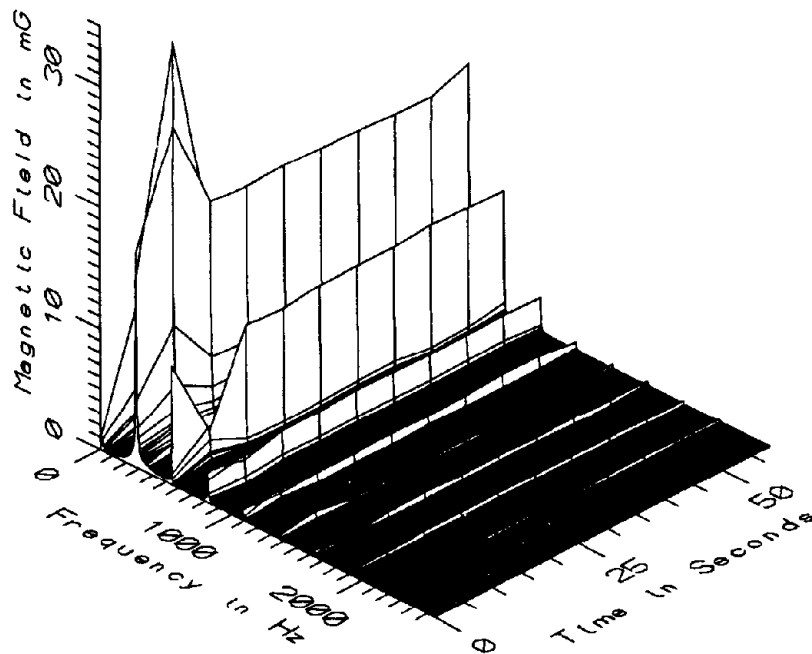

MET006 - 160cm ABOVE FLOOR, CENTER OF AISLE, CENTER OF CAR 3012

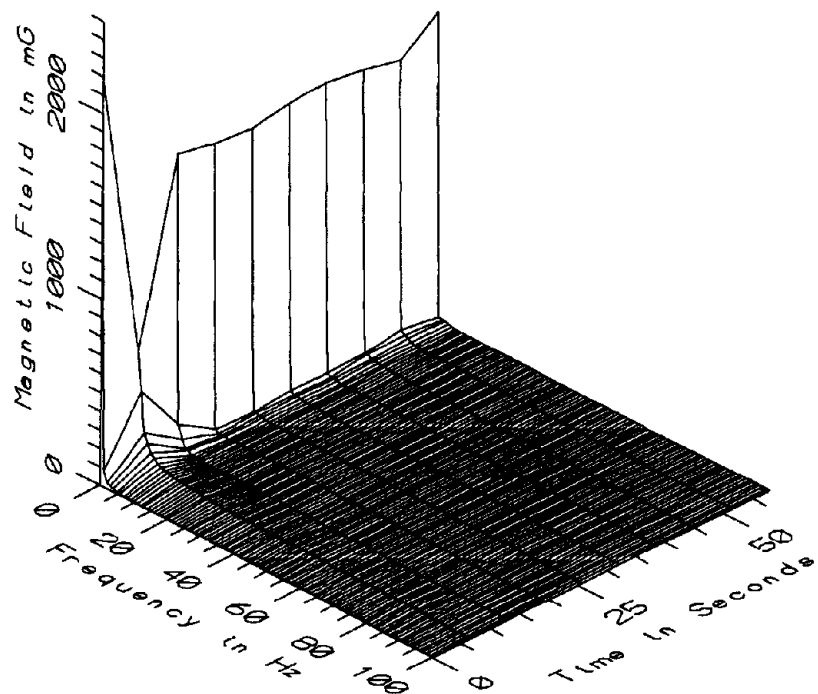

MET006 - REFERENCE PROBE - WINDOW SEAT NEAR CENTER OF CAR 3012

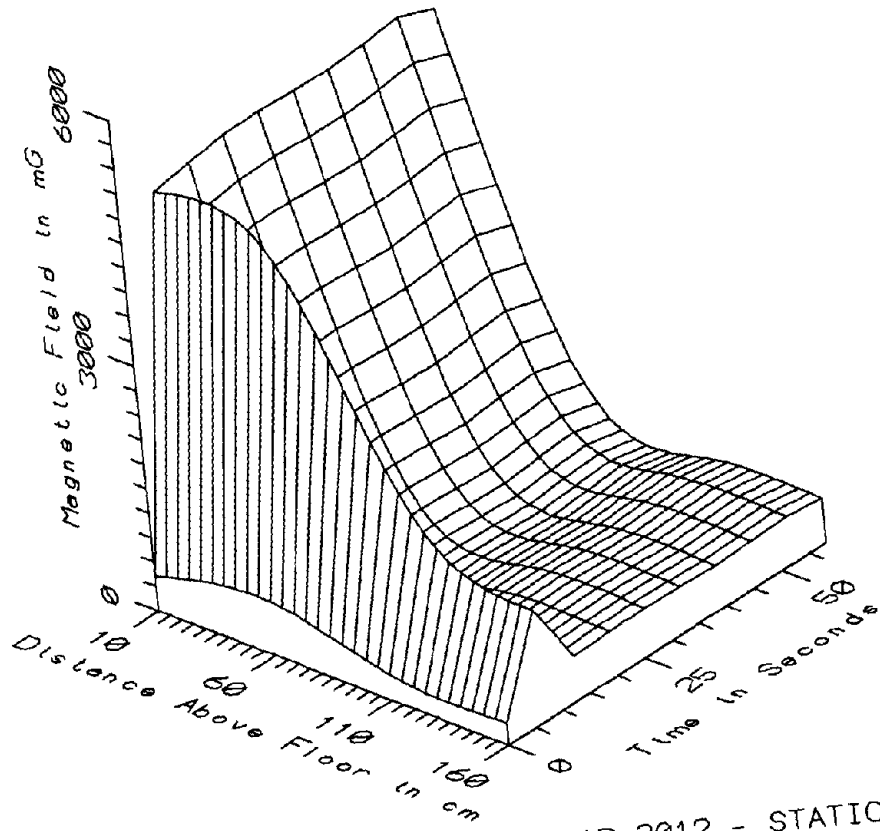

MET006 - CENTER OF AISLE, CENTER OF CAR 3012 - STATIC

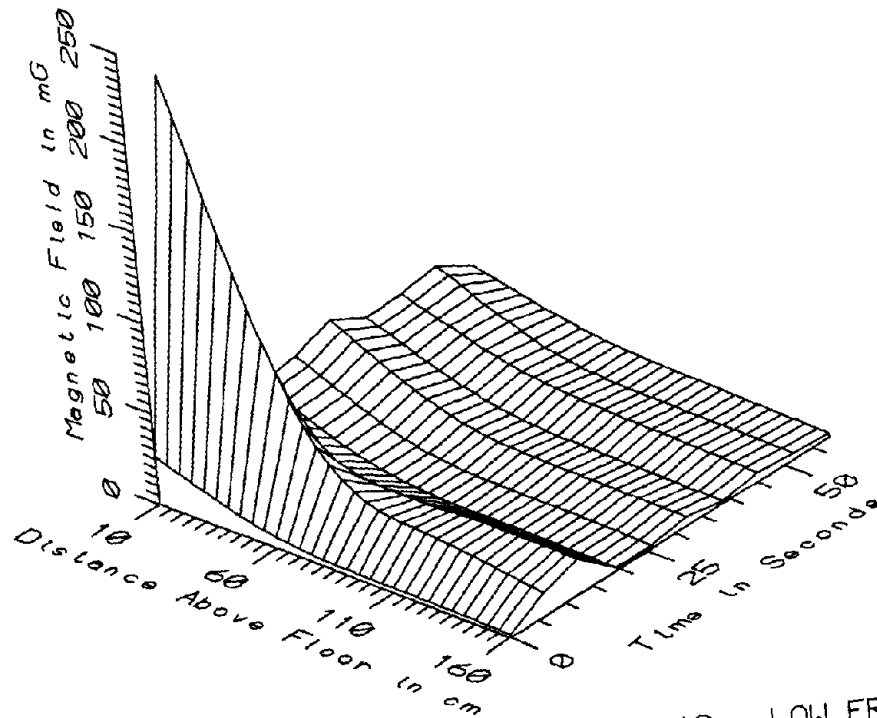

MET006 - CENTER OF AISLE, CENTER OF CAR 3012 - LOW FREQ, 5-45Hz

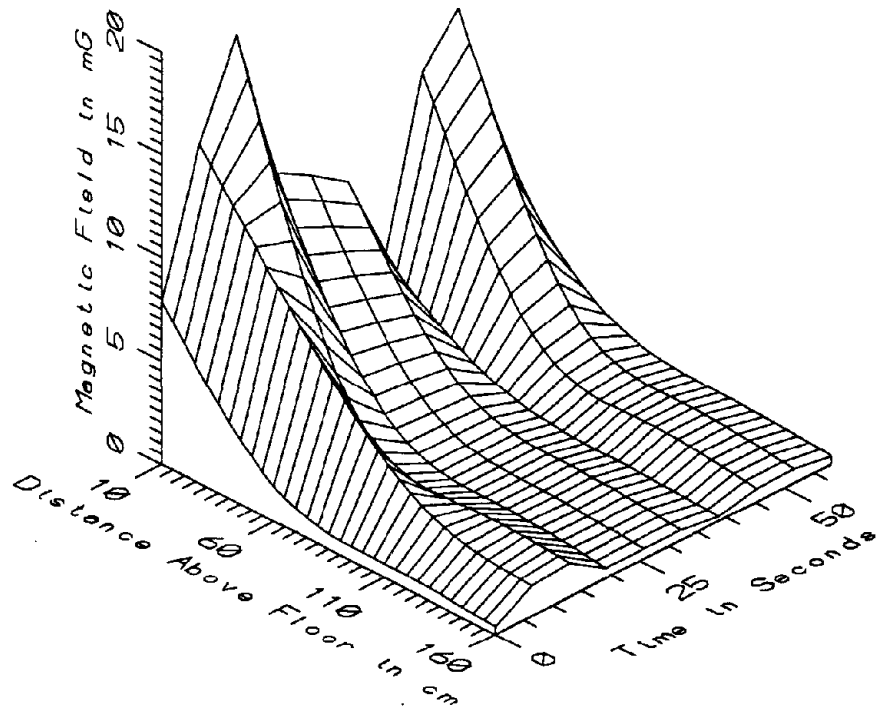

MET006 - CENTER OF AISLE, CENTER OF CAR 3012 - POWER FREQ, 50-60Hz

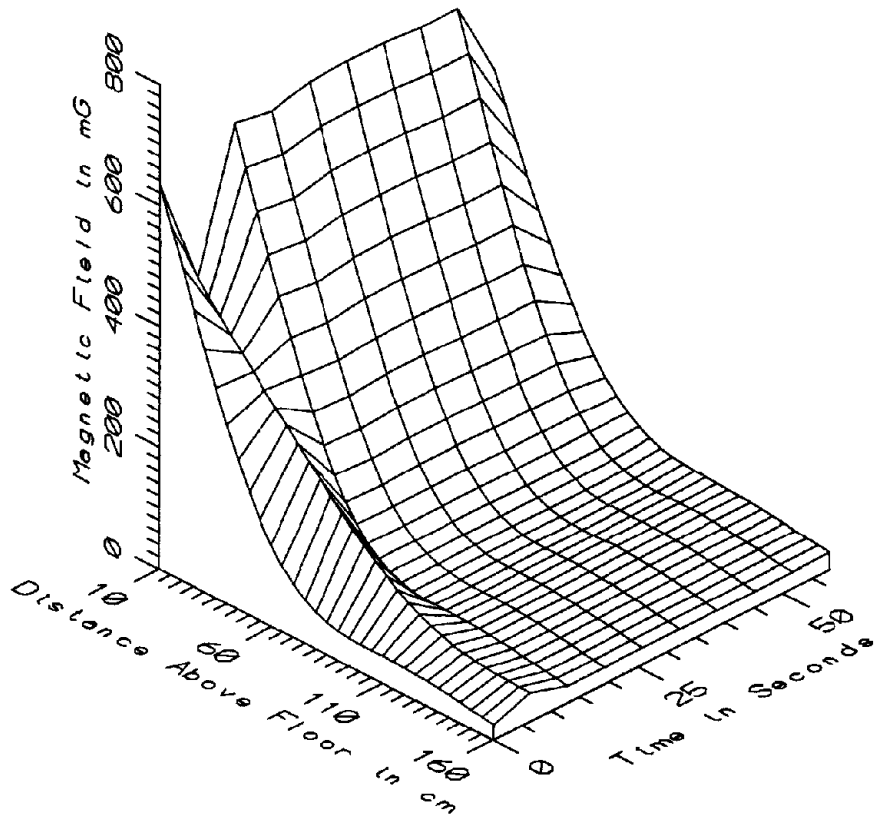

MET006 - CENTER OF AISLE, CENTER OF CAR 3012 - POWER HARM, 65-300Hz

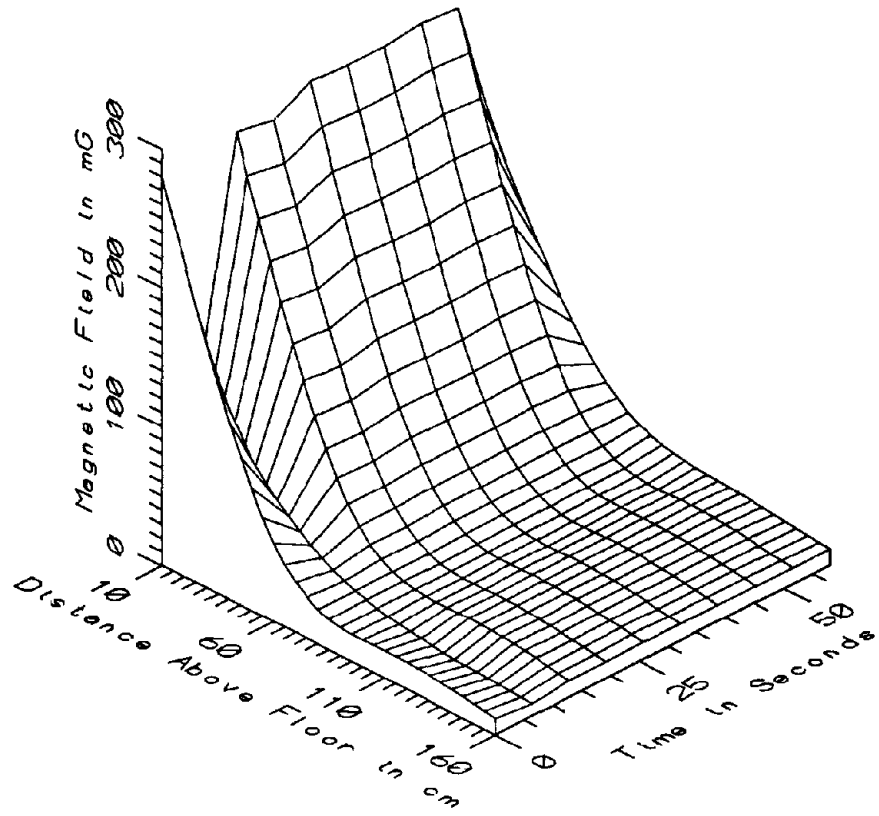

MET006 - CENTER OF AISLE, CENTER OF CAR 3012 - HIGH FREQ, 305-2560Hz

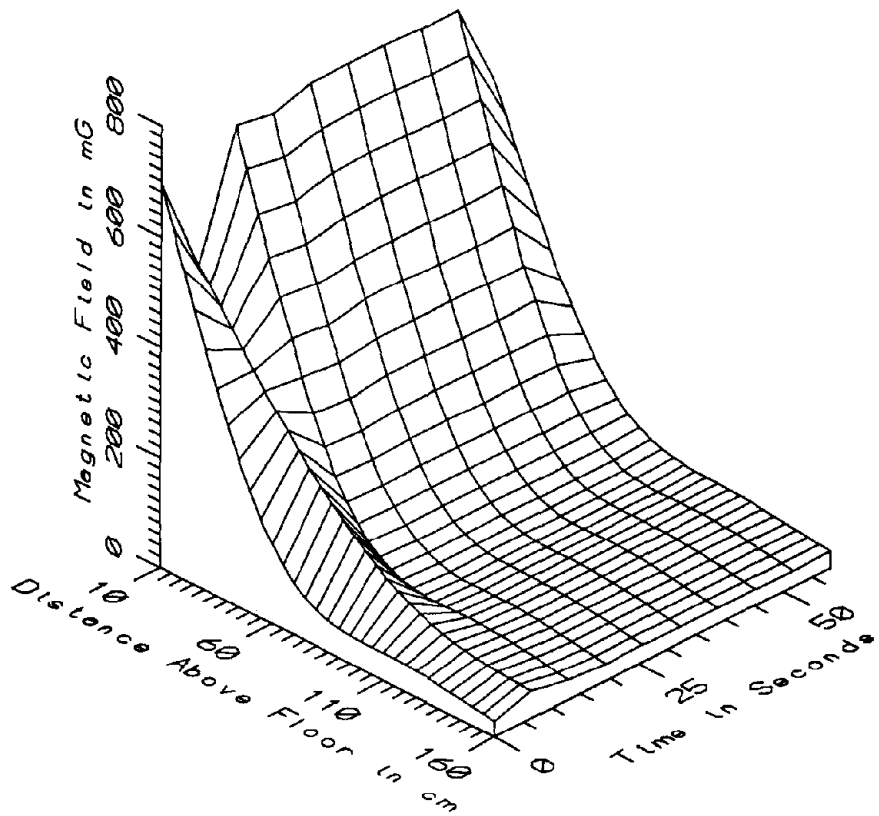

MET006 - CENTER OF AISLE, CENTER OF CAR 3012 - ALL FREQ, 5-2560Hz

MET006 - CENTER OF AISLE, CENTER OF CAR 3012		TOTAL OF 10 SAMPLES				
FREQUENCY BAND	HEIGHT ABOVE FLOOR (cm)	MINIMUM MAGNETIC FIELD (mG)	MAXIMUM MAGNETIC FIELD (mG)	AVERAGE MAGNETIC FIELD (mG)	STANDARD DEVIATION (mG)	COEFFICIENT OF VARIATION (%)
STATIC	10	435.56	31741.00	7215.32	8735.98	121.08
	60	655.65	5712.00	1379.42	1525.10	110.56
	110	308.10	1998.64	651.89	478.68	73.43
	160	266.97	1368.24	613.54	281.54	45.89
5-45HZ	10	20.92	226.34	51.34	61.85	120.47
LOW FREQ	60	6.26	55.73	14.37	15.11	105.10
	110	2.73	20.72	7.32	6.69	91.39
	160	1.71	18.99	5.53	5.76	104.23
50-60HZ	10	4.51	19.02	11.13	4.30	38.64
PWR FREQ	60	1.18	7.55	2.90	1.82	62.92
	110	0.45	2.57	1.11	0.62	56.00
	160	0.24	1.63	0.69	0.46	67.13
65-300HZ	10	446.70	683.69	636.14	79.01	12.42
PWR HARM	60	128.80	238.26	147.74	32.05	21.70
	110	44.82	81.29	50.64	10.82	21.36
	160	25.80	46.72	29.04	6.24	21.49
305-2560HZ	10	123.54	295.60	262.64	58.50	22.27
HIGH FREQ	60	41.65	59.33	55.66	5.49	9.87
	110	14.42	20.55	19.46	1.81	9.30
	160	8.41	12.05	11.35	1.06	9.37
5-2560HZ	10	515.99	744.79	694.73	81.08	11.67
ALL FREQ	60	138.69	248.32	159.38	31.60	19.82
	110	48.90	85.15	55.18	10.66	19.31
	160	28.20	49.11	32.15	6.27	19.52



APPENDIX G

DATASET MET007  
CENTER OF AISLE, CENTER OF CAR #3012

Measurement Setup Code:        Staff:     1     Reference:   9  
   Drawing:   A-1

Vehicle Status:                    Traveling on the Red Line

Measurement Date:                May 19, 1992

Measurement Time:                Start:     10:06:56  
   End:        10:08:36

Number of Samples:                12

Programmed Sample Interval:     5 sec

Actual Sample Interval:         9.1 sec

Frequency Spectrum Parameters

<u>Probe Type:</u>	<u>Wideband</u>	<u>Static</u>
Maximum Frequency (Hz)	2560	100
Minimum Frequency (Hz)	5	0
Spectral Bandwidth (Hz)	5	1

Missing Data: Wideband data from the reference probe

Saturated Data - Wideband:	<u>Sensor</u>	<u>Sample</u>	<u>Time (sec)</u>
	10cm	1	0
	10cm	2	9
	10cm	5	36
	10cm	9	73
	60cm	1	0
	60cm	9	73
	60cm	10	82
	60cm	11	91

Saturated Data - Static:	<u>Sensor</u>	<u>Sample</u>	<u>Time (sec)</u>
	10cm	10	82
	10cm	11	91

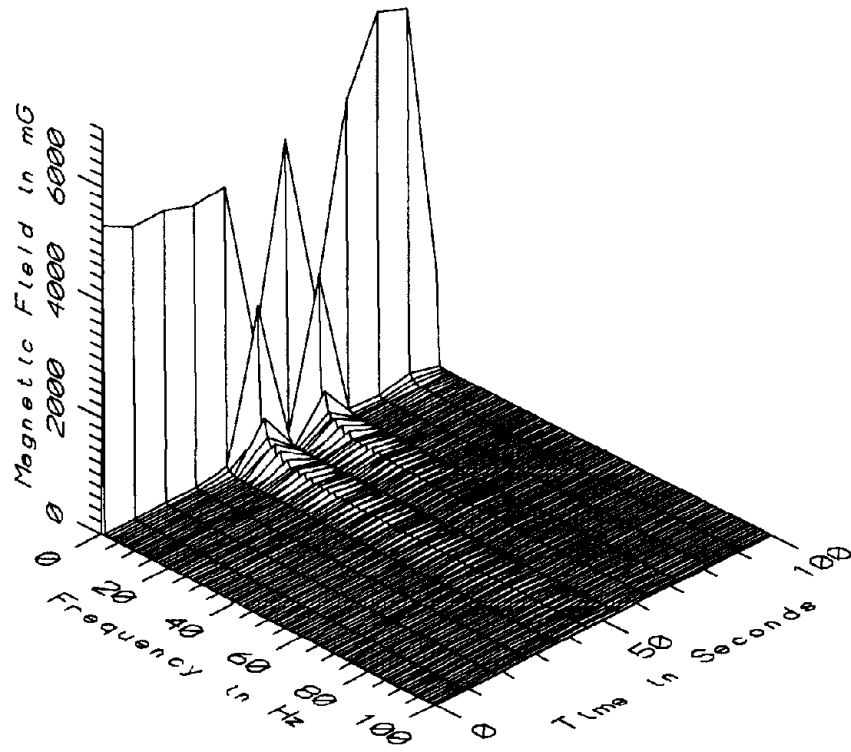

MET007 - 10cm ABOVE FLOOR, CENTER OF AISLE, CENTER OF CAR 3012

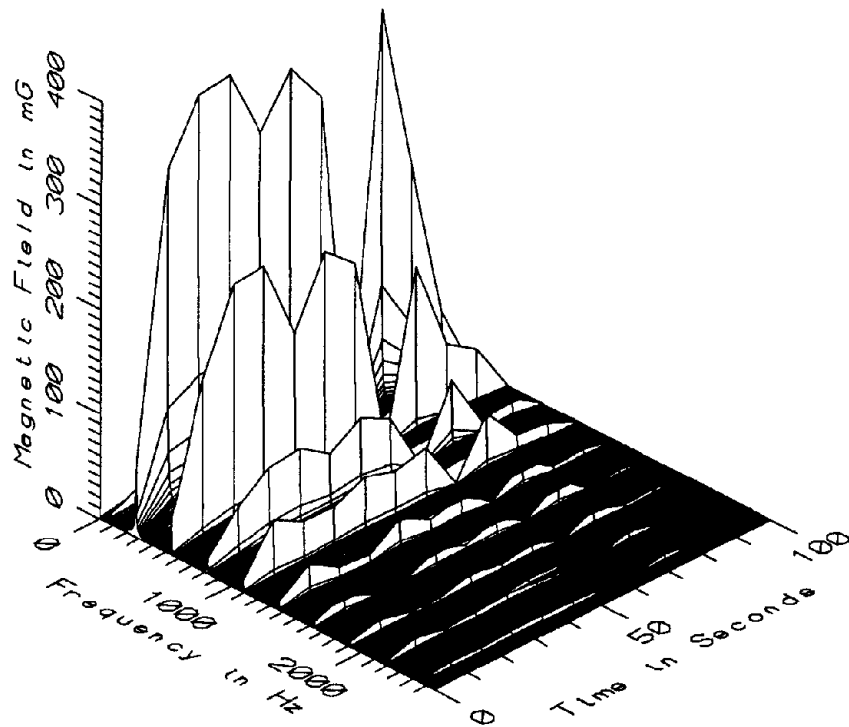

MET007 - 10cm ABOVE FLOOR, CENTER OF AISLE, CENTER OF CAR 3012

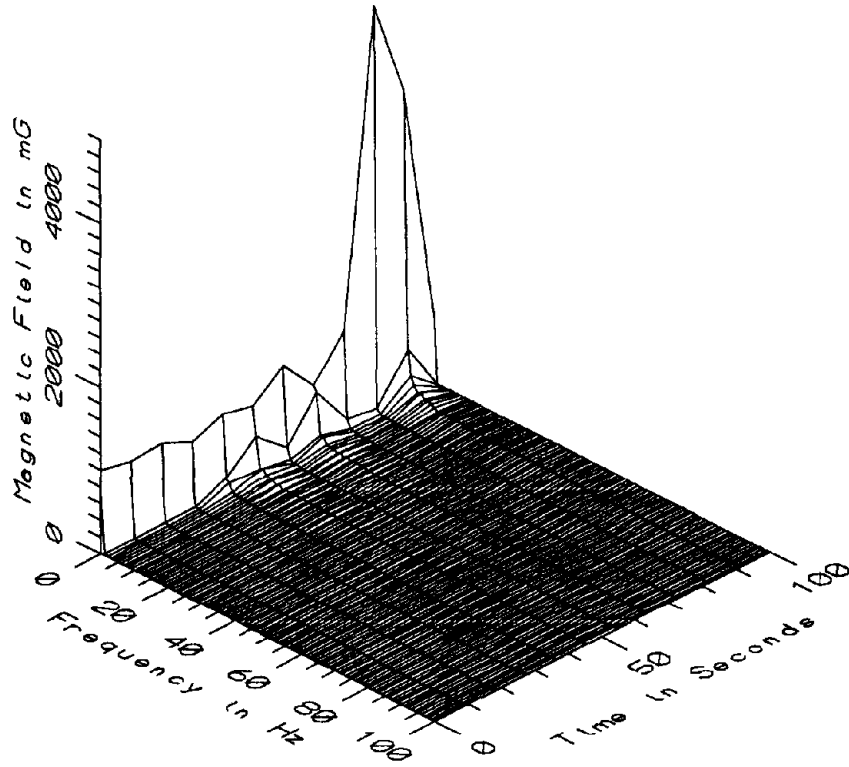

MET007 - 60cm ABOVE FLOOR, CENTER OF AISLE, CENTER OF CAR 3012

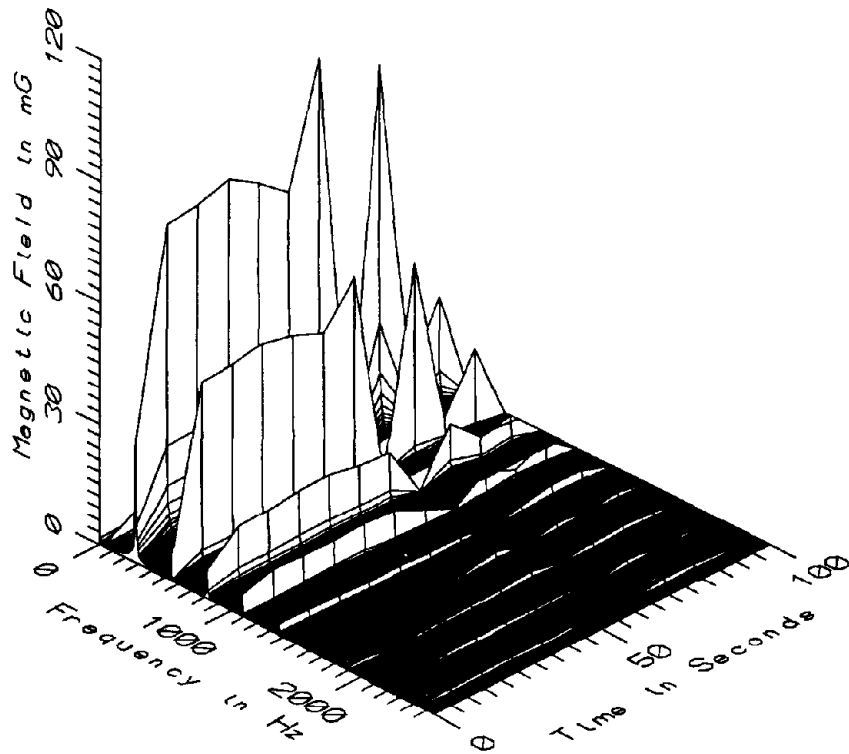

MET007 - 60cm ABOVE FLOOR, CENTER OF AISLE, CENTER OF CAR 3012

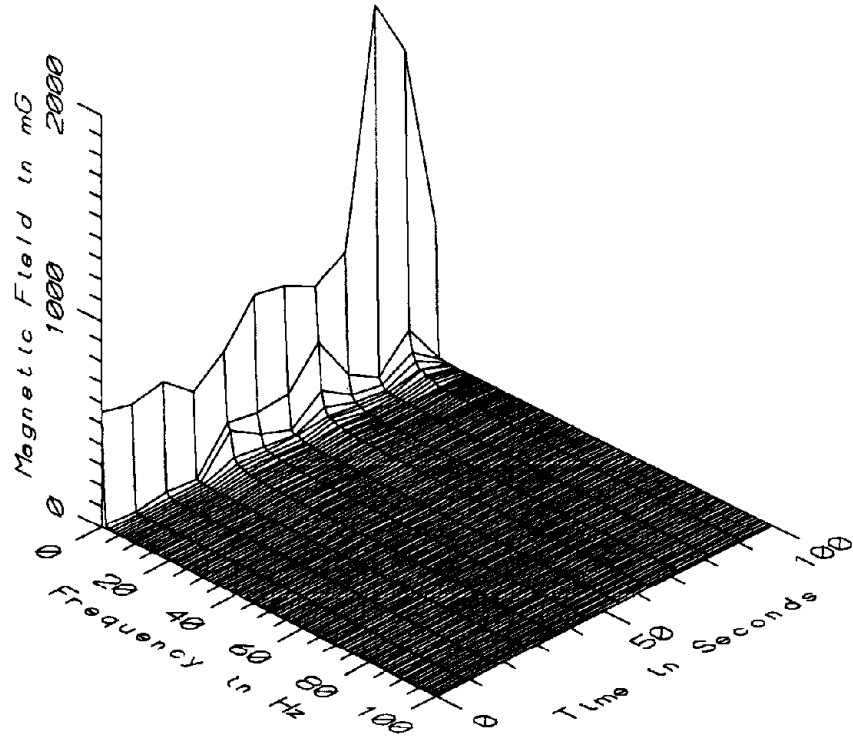

MET007 - 110cm ABOVE FLOOR, CENTER OF AISLE, CENTER OF CAR 3012

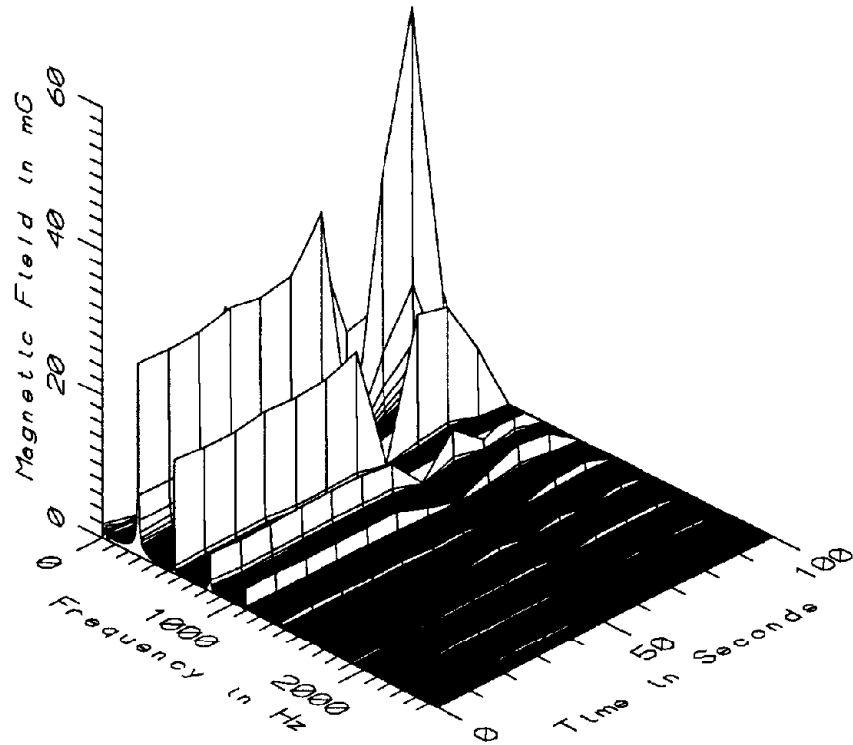

MET007 - 110cm ABOVE FLOOR, CENTER OF AISLE, CENTER OF CAR 3012

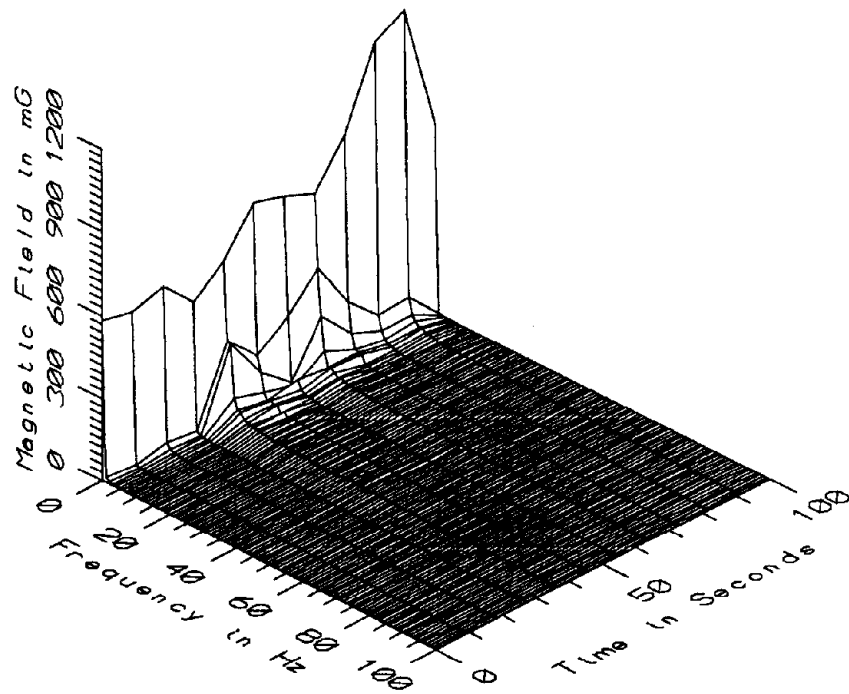

MET007 - 160cm ABOVE FLOOR, CENTER OF AISLE, CENTER OF CAR 3012

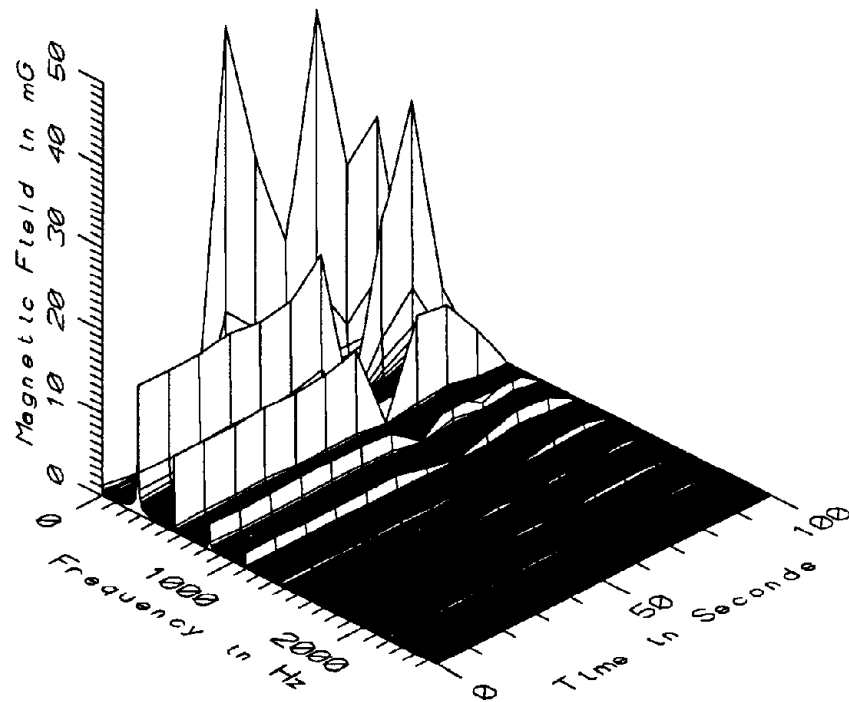

MET007 - 160cm ABOVE FLOOR, CENTER OF AISLE, CENTER OF CAR 3012

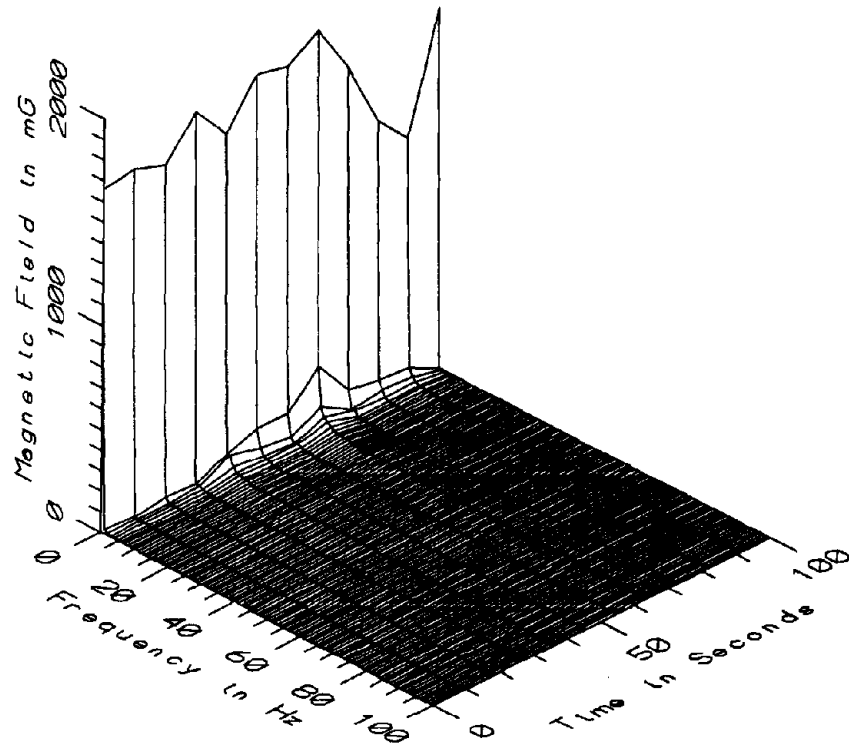

MET007 - REFERENCE PROBE - WINDOW SEAT NEAR CENTER OF CAR 3012

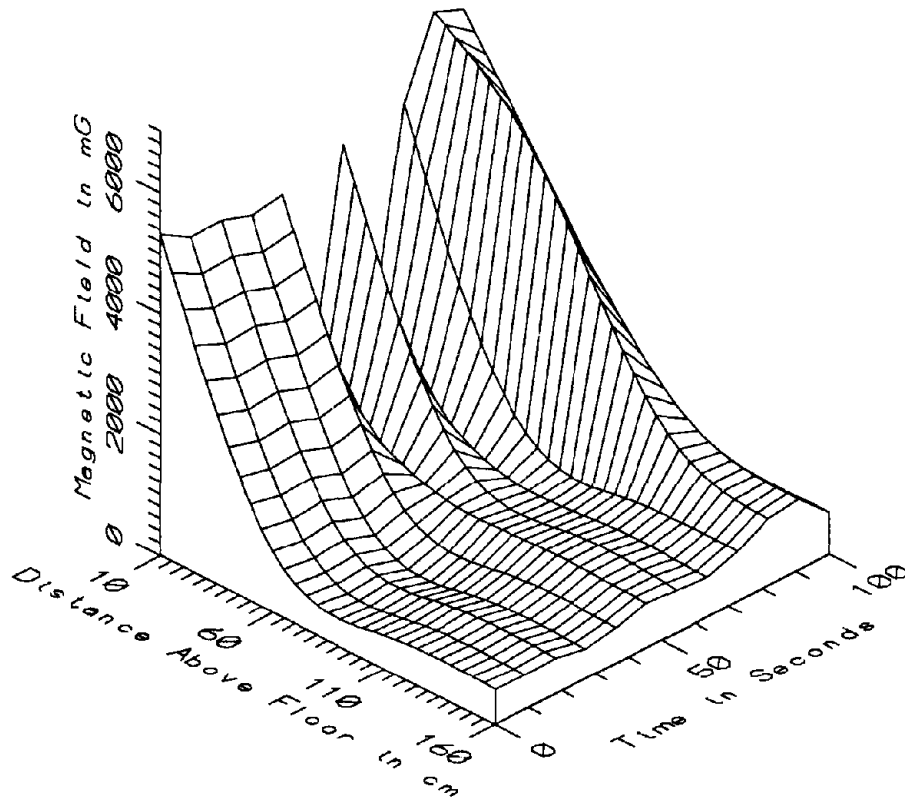

MET007 - CENTER OF AISLE, CENTER OF CAR 3012 - STATIC

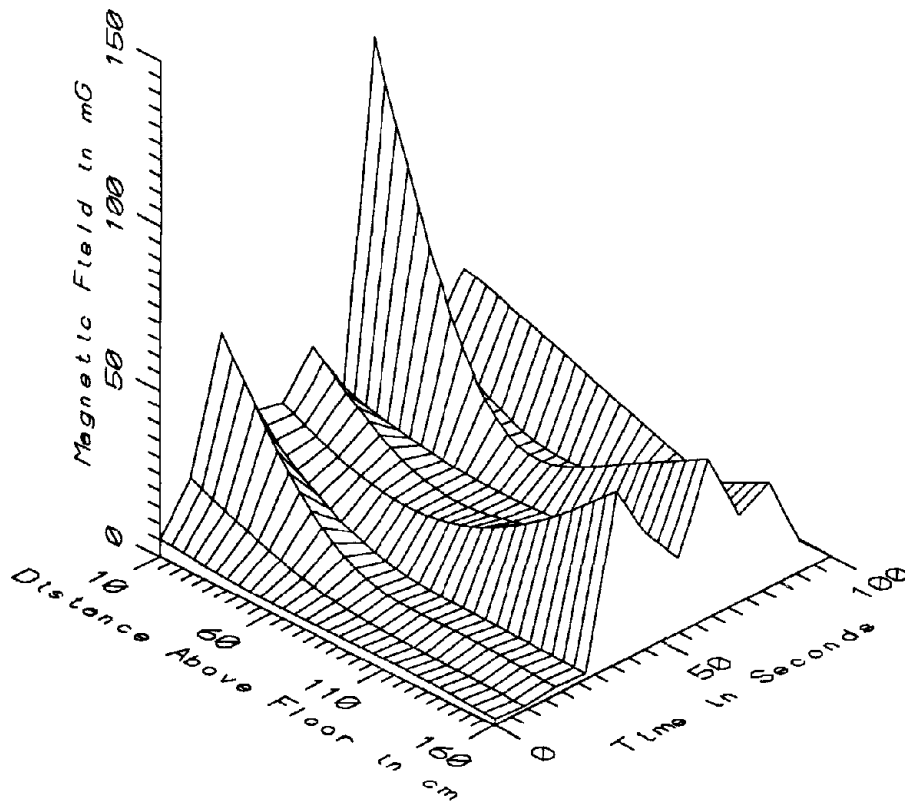

MET007 - CENTER OF AISLE, CENTER OF CAR 3012 - LOW FREQ, 5-45Hz

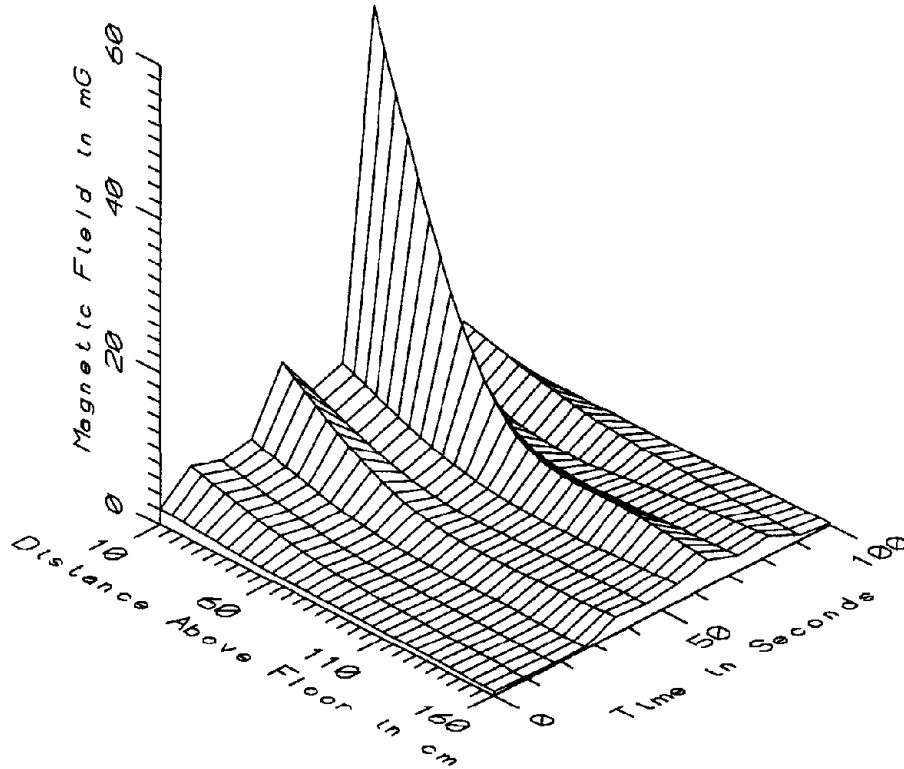

MET007 - CENTER OF AISLE, CENTER OF CAR 3012 - POWER FREQ, 50-60Hz

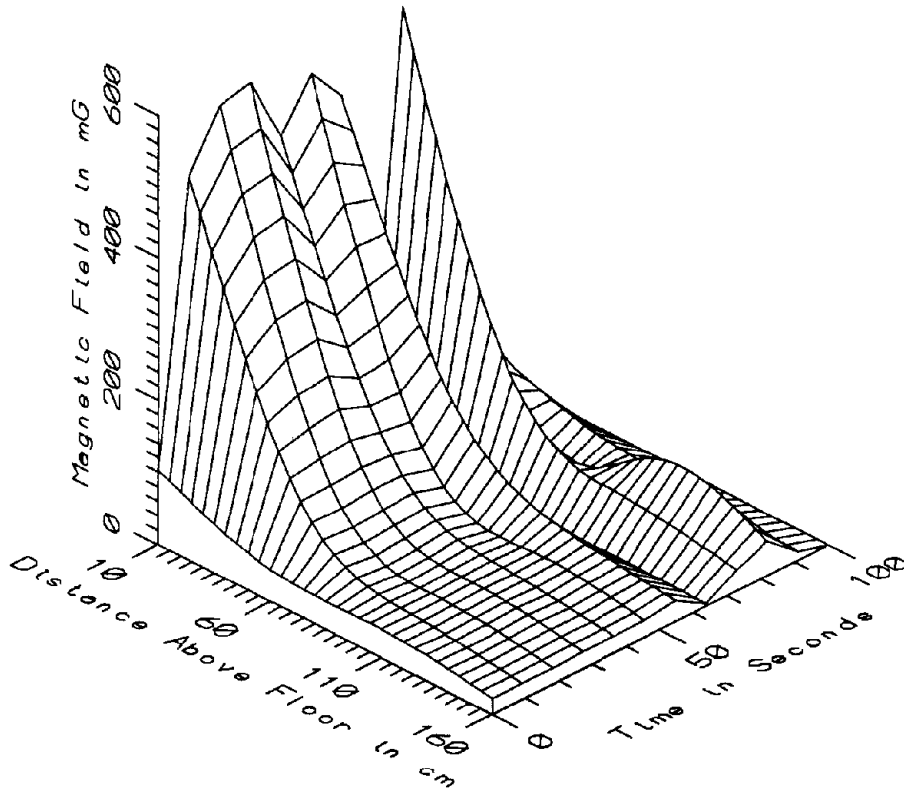

MET007 - CENTER OF AISLE, CENTER OF CAR 3012 - POWER HARM, 65-300Hz



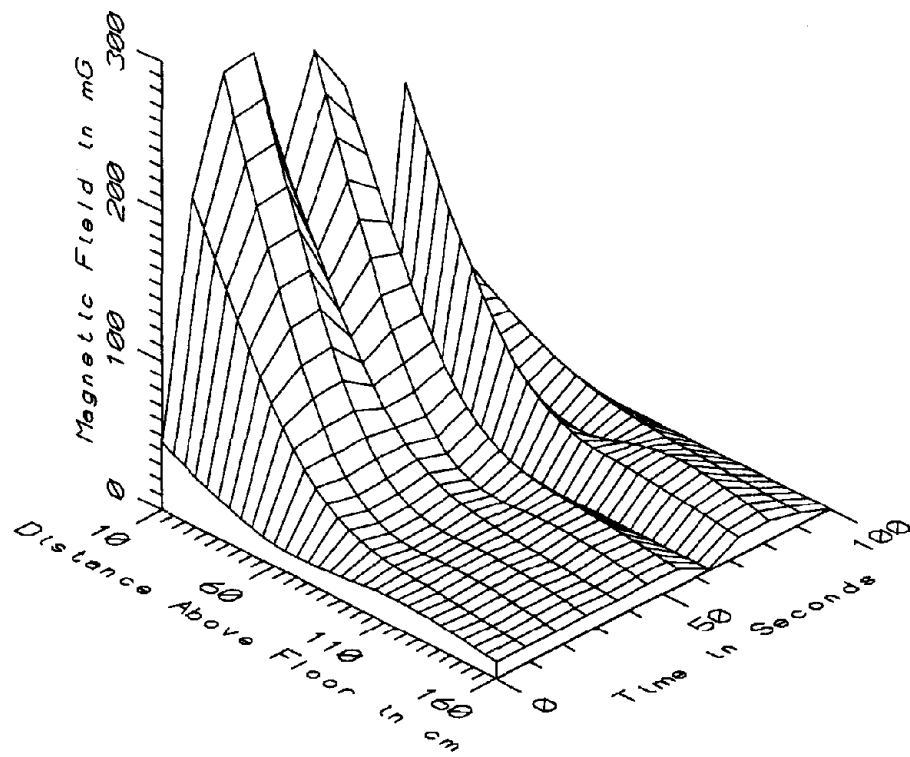

MET007 - CENTER OF AISLE, CENTER OF CAR 3012 - HIGH FREQ, 305-2560Hz

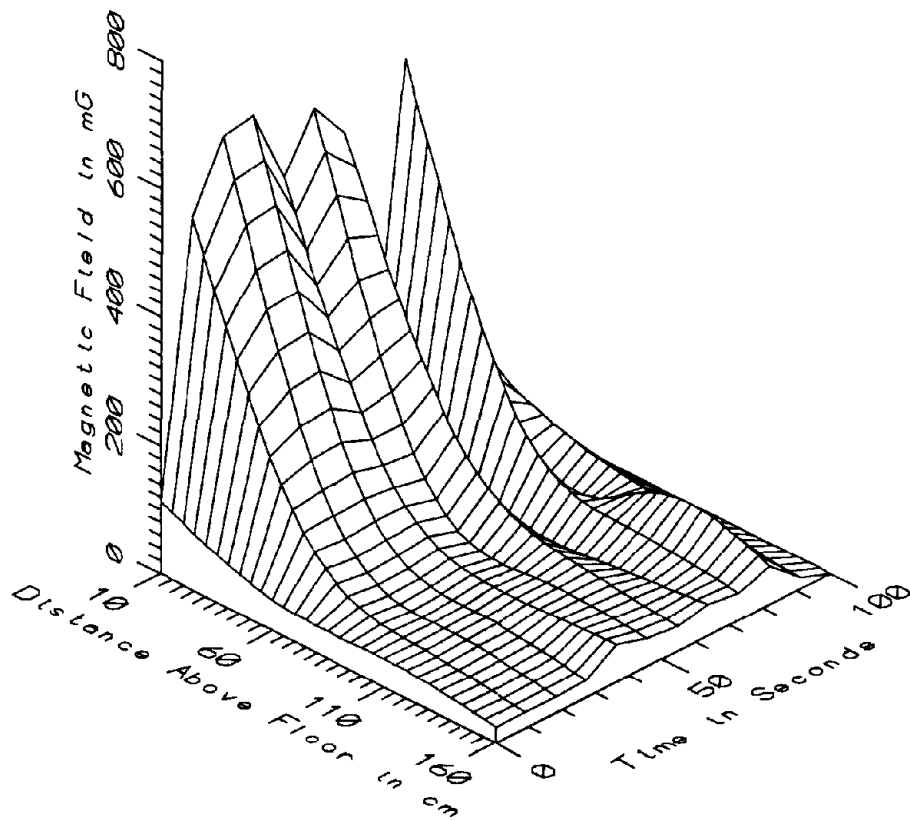

MET007 - CENTER OF AISLE, CENTER OF CAR 3012 - ALL FREQ, 5-2560Hz

MET007 - CENTER OF AISLE, CENTER OF CAR 3012		TOTAL OF 12 SAMPLES				
FREQUENCY BAND	HEIGHT ABOVE FLOOR (cm)	MINIMUM MAGNETIC FIELD (mG)	MAXIMUM MAGNETIC FIELD (mG)	AVERAGE MAGNETIC FIELD (mG)	STANDARD DEVIATION (mG)	COEFFICIENT OF VARIATION (%)
STATIC	10	1628.73	40471.00	9108.43	11975.14	131.47
	60	714.34	4934.77	1490.98	1359.05	91.15
	110	431.69	1857.24	795.86	443.11	55.68
	160	483.10	1148.73	715.84	206.52	28.85
5-45HZ	10	0.85	124.35	35.12	31.97	91.02
LOW FREQ	60	0.41	32.10	12.93	9.67	74.81
	110	0.22	28.95	12.31	9.64	78.29
	160	0.29	52.12	19.41	19.21	98.99
50-60HZ	10	0.55	53.78	10.57	14.15	133.81
PWR FREQ	60	0.35	12.30	2.78	3.20	115.43
	110	0.32	4.91	1.38	1.22	88.40
	160	0.20	3.49	1.39	1.13	81.58
65-300HZ	10	0.84	581.23	363.53	228.07	62.74
PWR HARM	60	0.28	149.68	82.07	53.31	64.95
	110	0.33	83.12	37.91	21.60	56.96
	160	0.21	48.62	22.07	12.51	56.68
305-2560HZ	10	1.51	275.91	152.54	103.91	68.12
HIGH FREQ	60	0.30	58.32	36.06	23.10	64.05
	110	0.15	22.47	15.94	7.46	46.79
	160	0.08	13.17	9.44	4.25	44.98
5-2560HZ	10	2.00	644.11	403.00	240.57	59.69
ALL FREQ	60	0.68	161.50	92.77	55.20	59.50
	110	0.53	87.48	45.02	20.45	45.42
	160	0.44	59.68	34.30	17.42	50.78

**APPENDIX H**  
**DATASET MET008**  
**CENTER OF AISLE, REAR OF CAR #3012**

Measurement Setup Code:           Staff:     5     Reference:  11  
   Drawing:  A-1

Vehicle Status:                    Traveling on the Red Line

Measurement Date:                 May 19, 1992

Measurement Time:                 Start:     10:12:21  
   End:       10:15:10

Number of Samples:                 16

Programmed Sample Interval:       5 sec

Actual Sample Interval:            11.3 sec

**Frequency Spectrum Parameters**

<u>Probe Type:</u>	<u>Wideband</u>	<u>Static</u>
Maximum Frequency (Hz)	2560	100
Minimum Frequency (Hz)	5	0
Spectral Bandwidth (Hz)	5	1

Missing Data:  None

Saturated Data - Wideband:	<u>Sensor</u>	<u>Sample</u>	<u>Time (sec)</u>
	10cm	15	158
	60cm	15	158
	110cm	11	113
	Ref	8	79

Saturated Data - Static:	<u>Sensor</u>	<u>Sample</u>	<u>Time (sec)</u>
	10cm	2	11

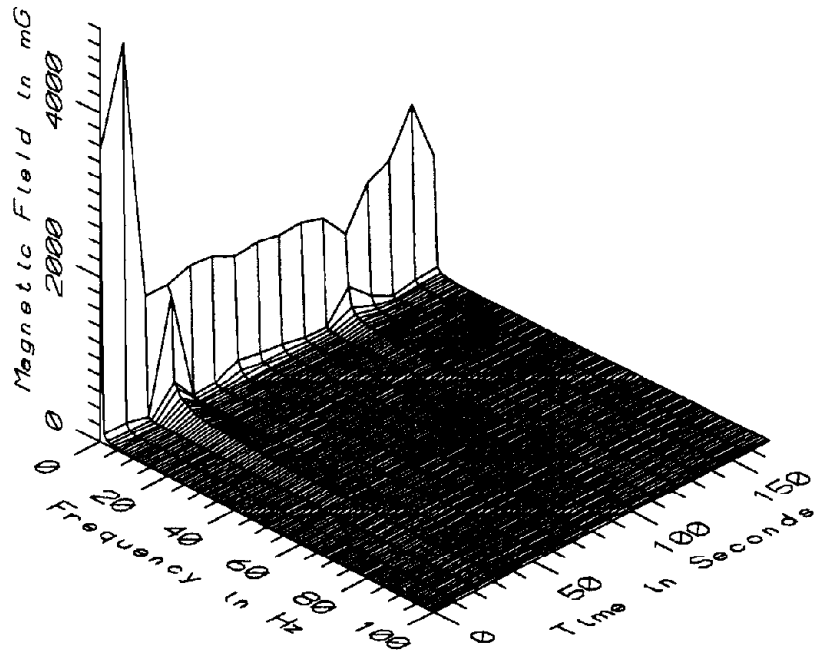

MET008 - 10cm ABOVE FLOOR, CENTER OF AISLE, REAR OF CAR 3012

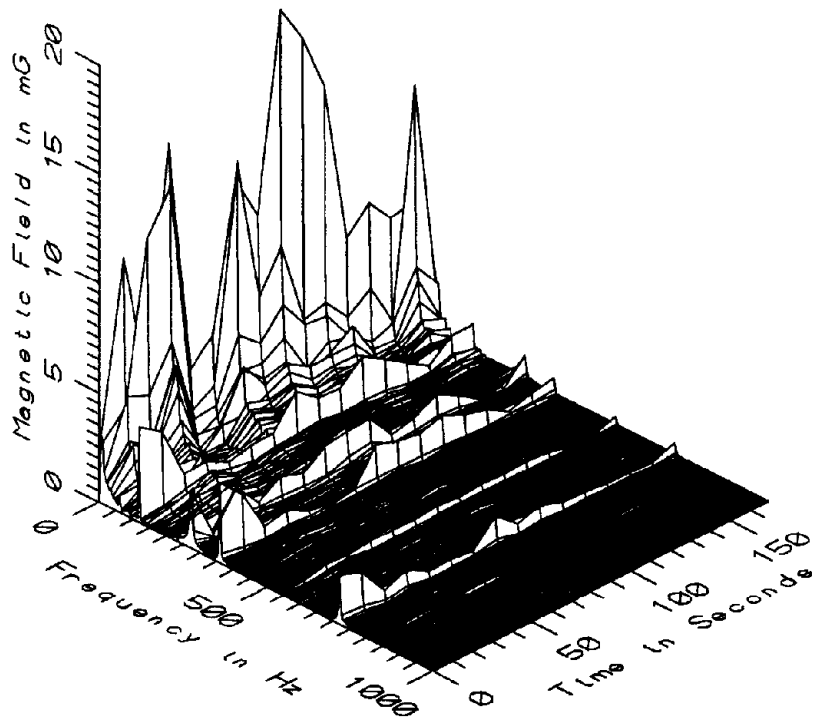

MET008 - 10cm ABOVE FLOOR, CENTER OF AISLE, REAR OF CAR 3012

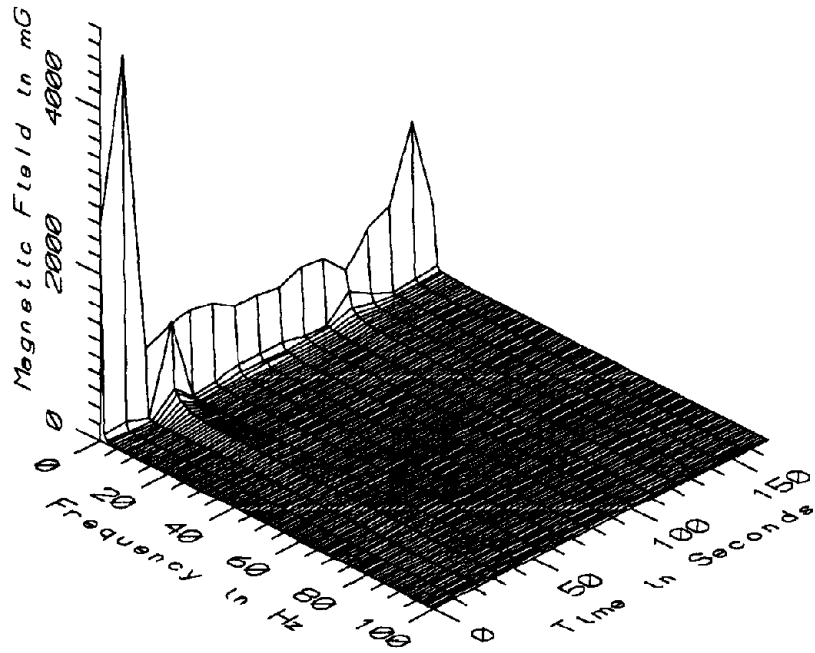

MET008 - 60cm ABOVE FLOOR, CENTER OF AISLE, REAR OF CAR 3012

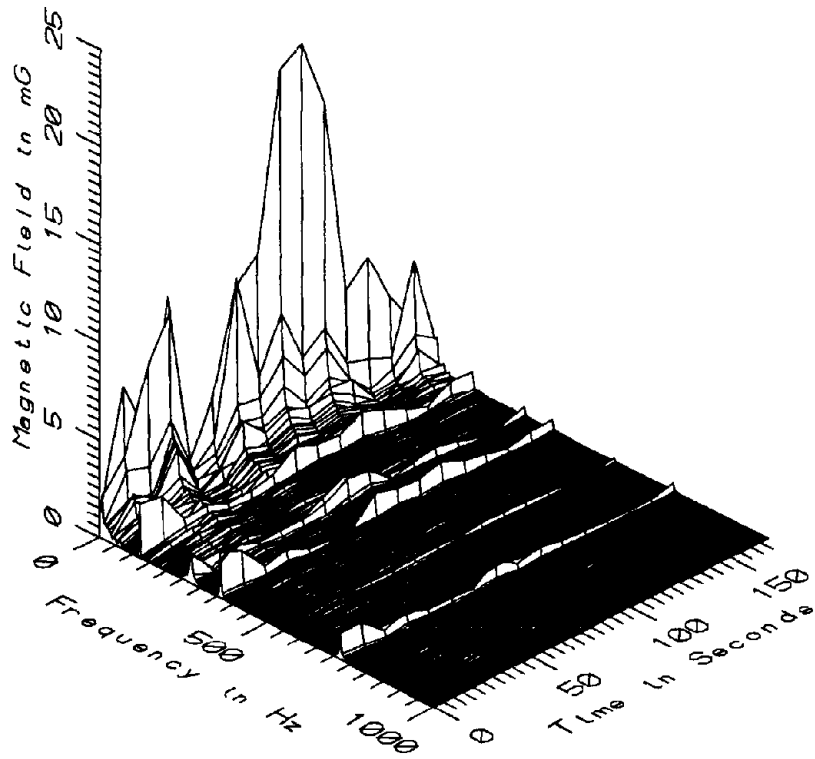

MET008 - 60cm ABOVE FLOOR, CENTER OF AISLE, REAR OF CAR 3012

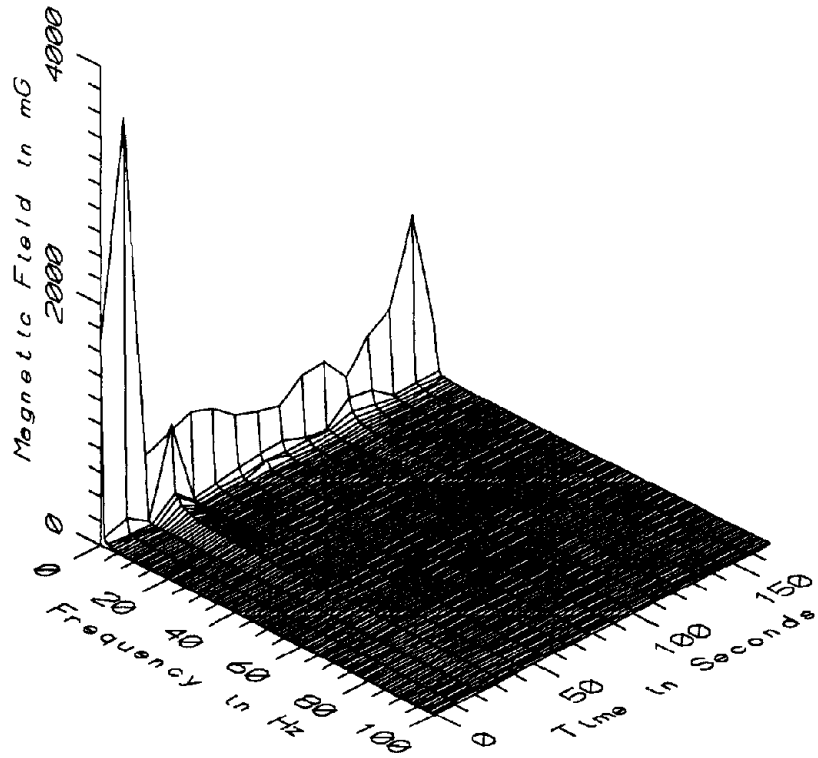

MET008 - 110cm ABOVE FLOOR, CENTER OF AISLE, REAR OF CAR 3012

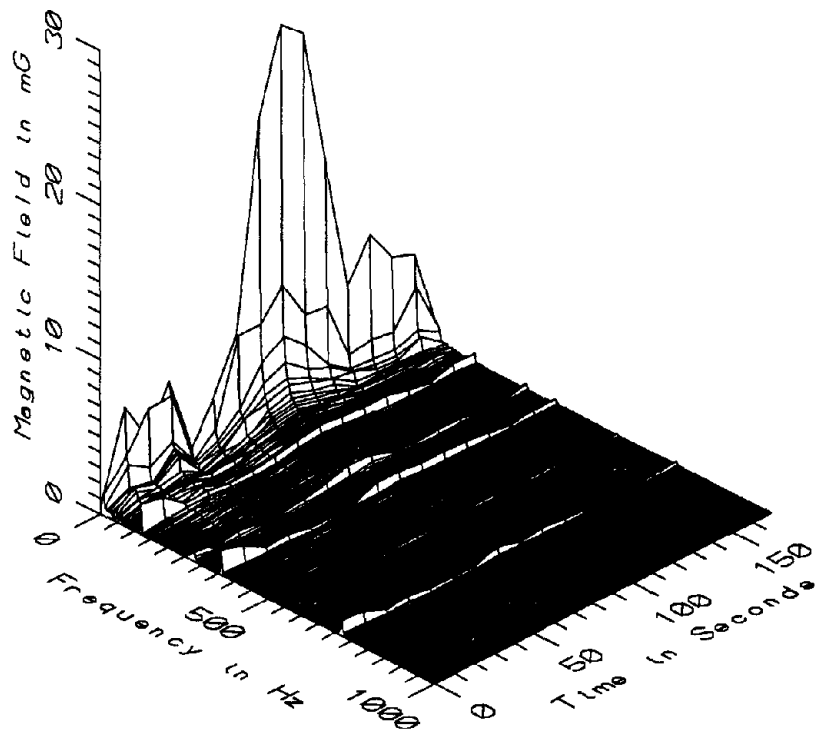

MET008 - 110cm ABOVE FLOOR, CENTER OF AISLE, REAR OF CAR 3012

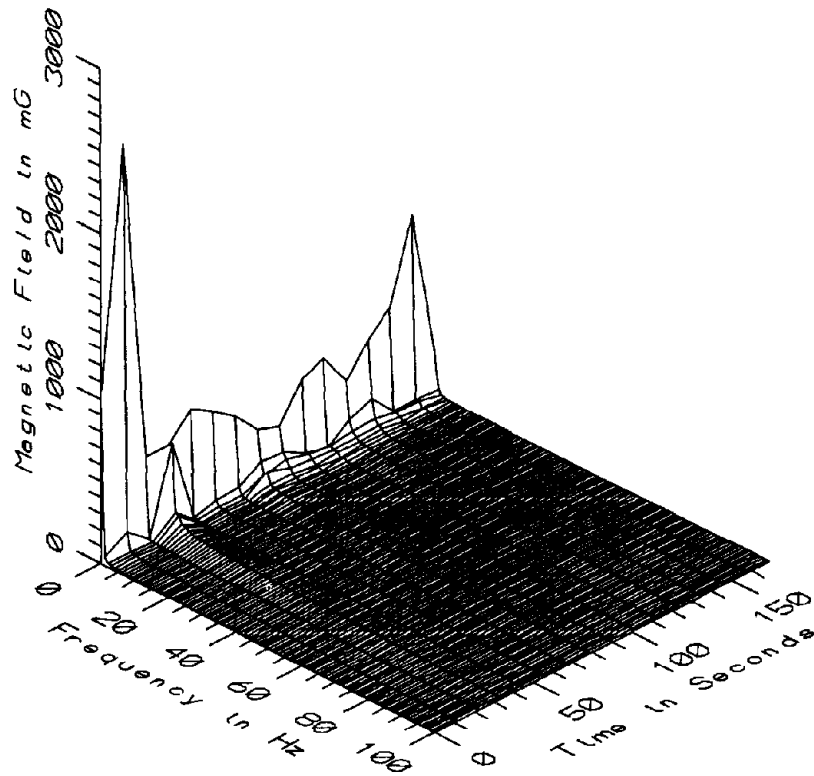

MET008 - 160cm ABOVE FLOOR, CENTER OF AISLE, REAR OF CAR 3012

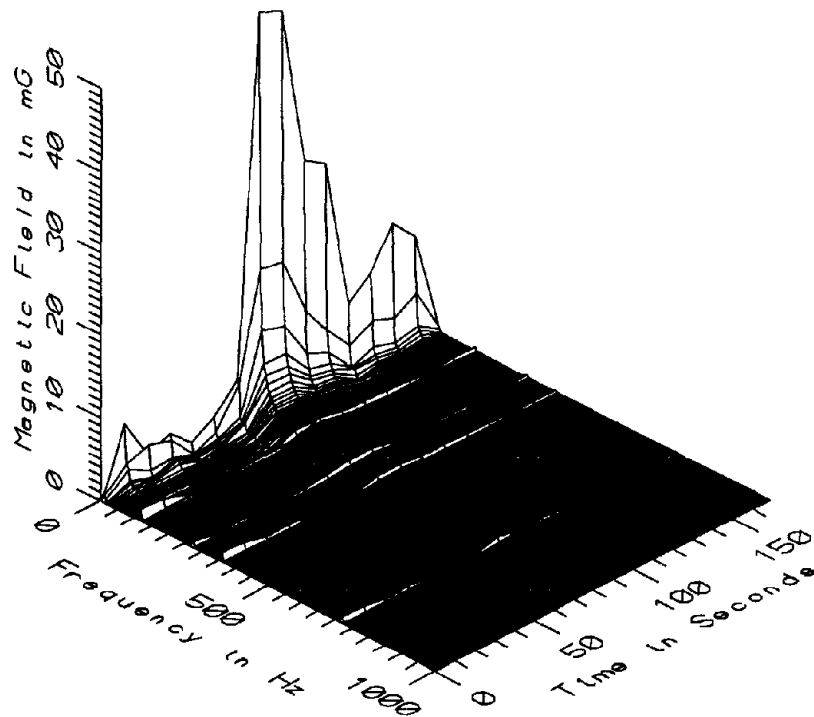

MET008 - 160cm ABOVE FLOOR, CENTER OF AISLE, REAR OF CAR 3012

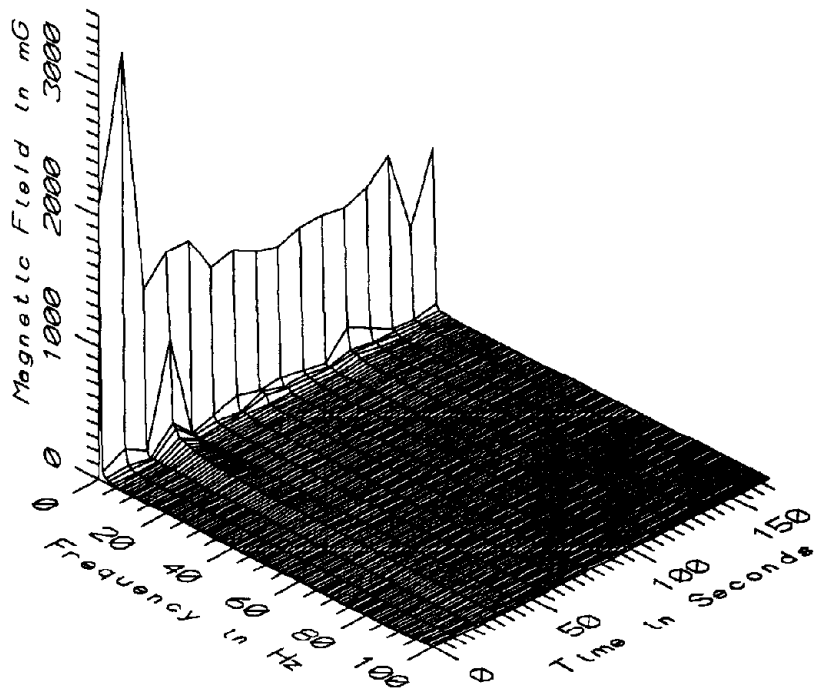

MET008 - REFERENCE PROBE - OPERATOR'S SEAT, CAR 3012

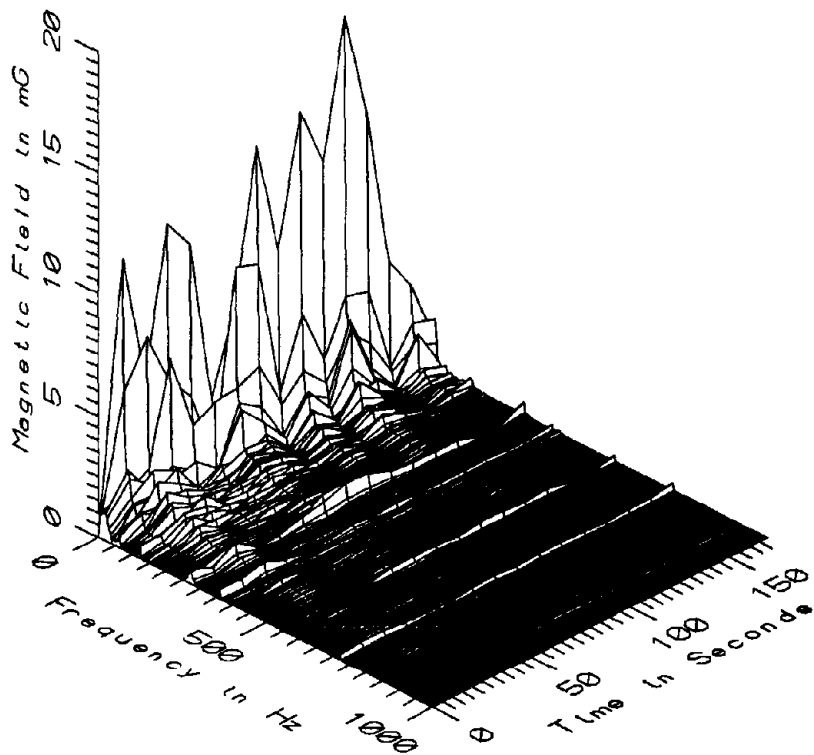

MET008 - REFERENCE PROBE - OPERATOR'S SEAT, CAR 3012



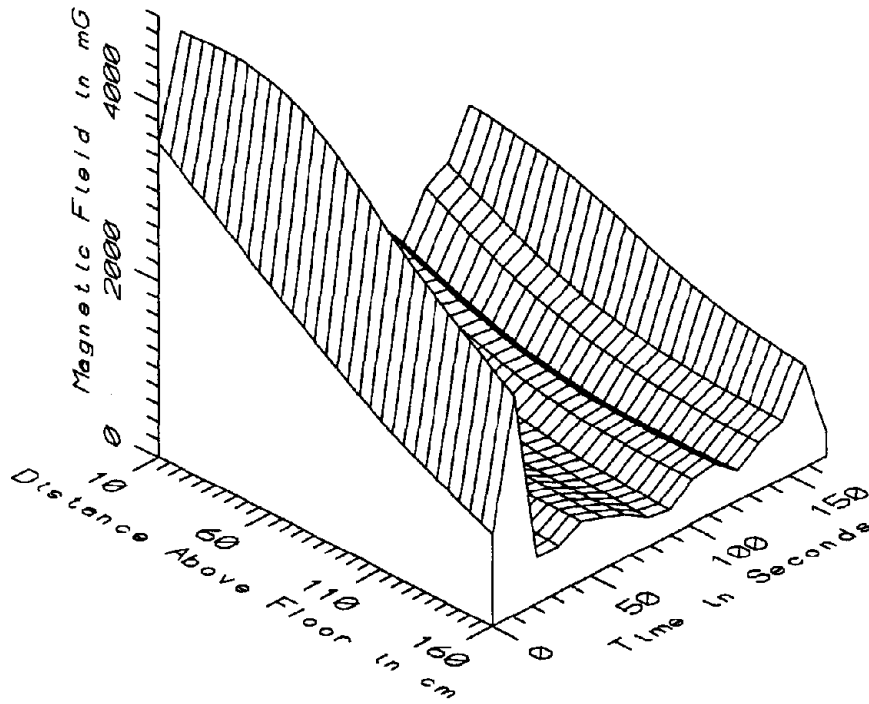

MET008 - CENTER OF AISLE, REAR OF CAR 3012 - STATIC

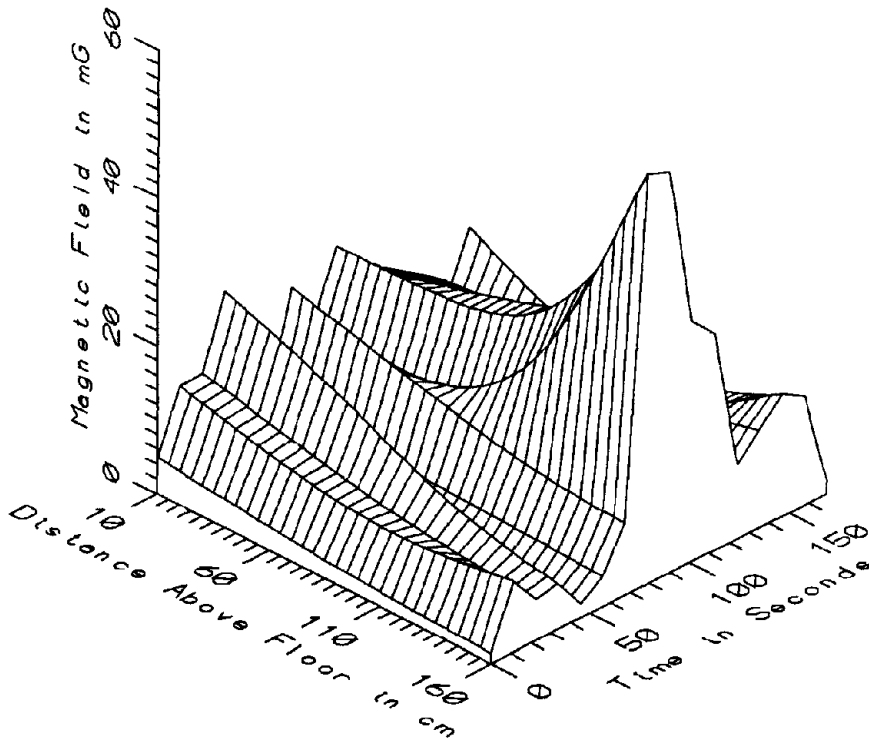

MET008 - CENTER OF AISLE, REAR OF CAR 3012 - LOW FREQ, 5-45Hz

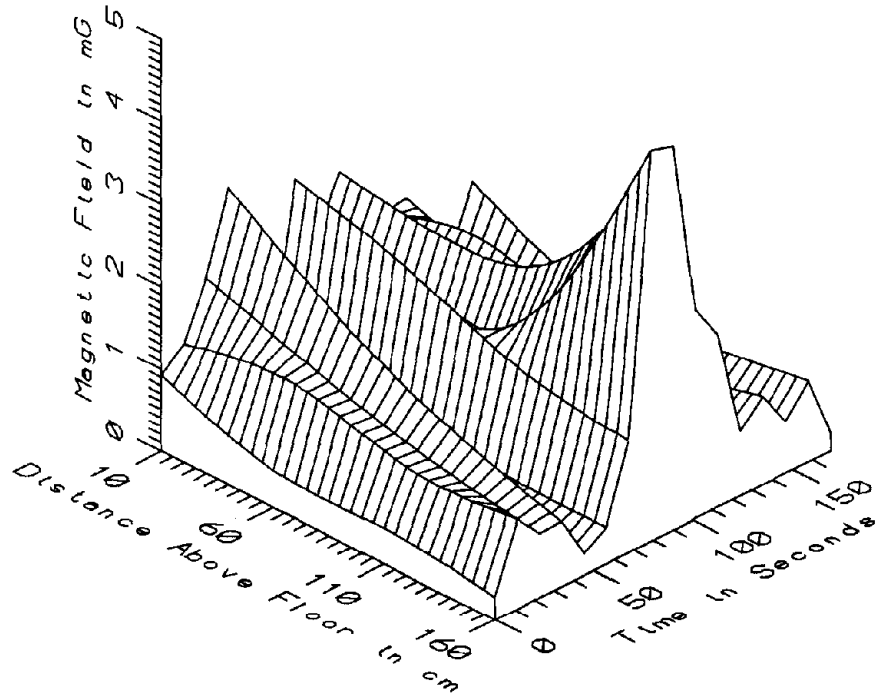

MET008 - CENTER OF AISLE, REAR OF CAR 3012 - POWER FREQ, 50-60Hz

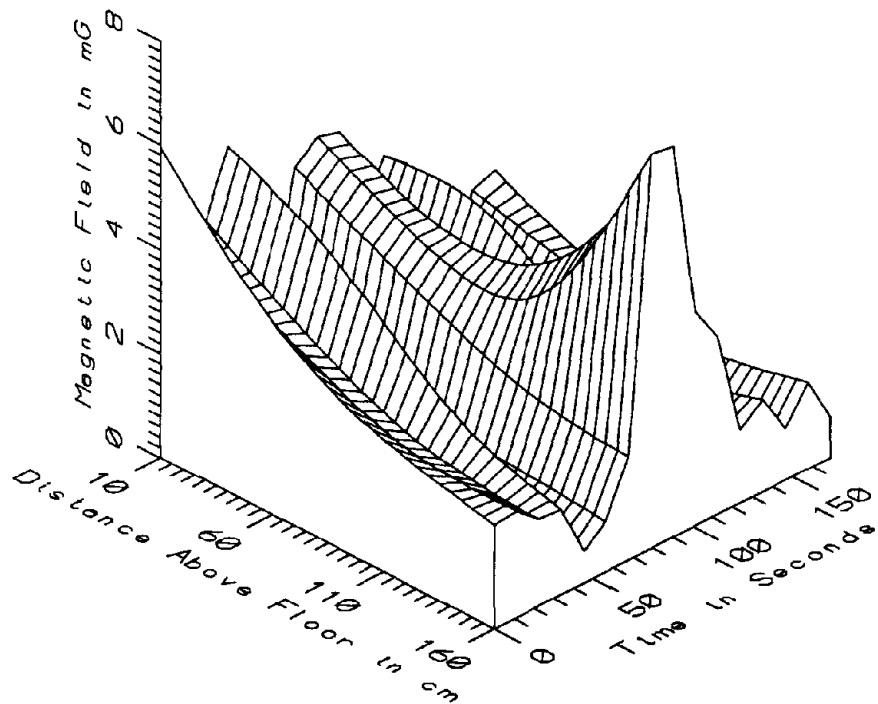

MET008 - CENTER OF AISLE, REAR OF CAR 3012 - POWER HARM, 65-300Hz

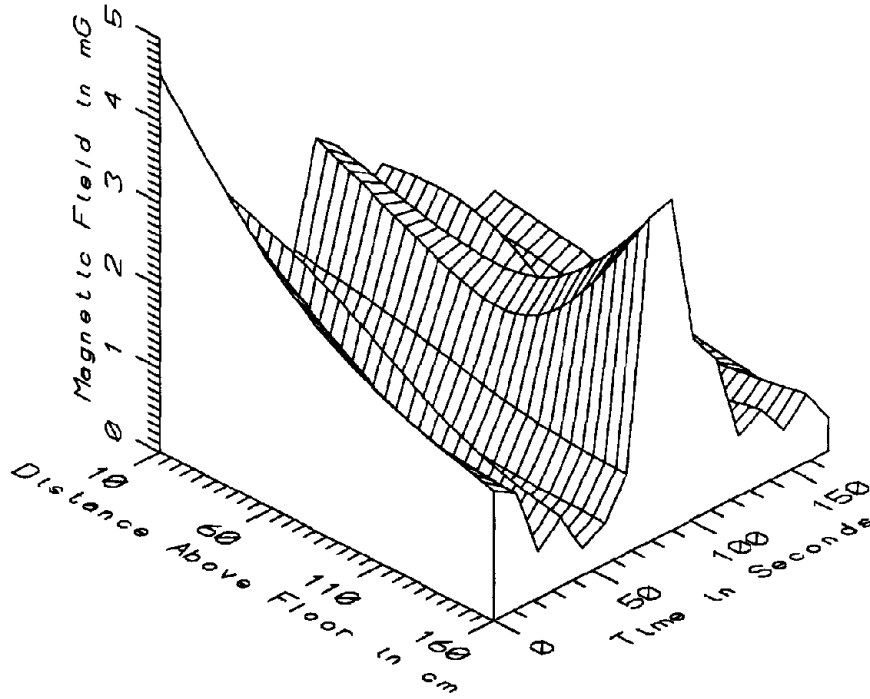

MET008 - CENTER OF AISLE, REAR OF CAR 3012 - HIGH FREQ, 305-2560Hz

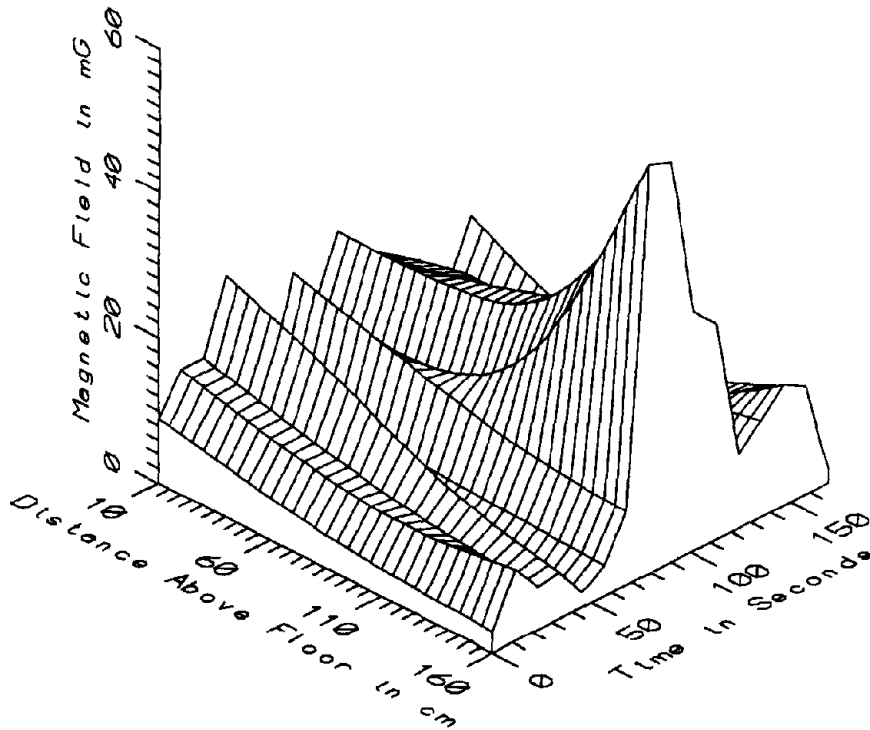

MET008 - CENTER OF AISLE, REAR OF CAR 3012 - ALL FREQ, 5-2560Hz

MET008 - CENTER OF AISLE, REAR OF CAR #3012		TOTAL OF 16 SAMPLES				
FREQUENCY BAND	HEIGHT ABOVE FLOOR (cm)	MINIMUM MAGNETIC FIELD (mG)	MAXIMUM MAGNETIC FIELD (mG)	AVERAGE MAGNETIC FIELD (mG)	STANDARD DEVIATION (mG)	COEFFICIENT OF VARIATION (%)
STATIC	10	1026.45	4708.21	1837.37	948.33	51.61
	60	543.36	4538.66	1254.32	1012.84	80.75
	110	355.19	3462.37	858.29	783.37	91.27
	160	262.81	2467.74	683.72	533.51	78.03
5-45Hz LOW FREQ	10	4.32	22.79	12.14	5.98	49.27
	60	2.67	21.84	10.53	6.35	60.37
	110	1.73	28.79	10.93	8.49	77.71
	160	1.29	55.66	16.64	17.46	104.93
50-60Hz PWR FREQ	10	0.57	2.79	1.40	0.70	49.74
	60	0.40	2.14	1.14	0.61	53.75
	110	0.30	2.60	1.09	0.68	62.39
	160	0.23	4.74	1.42	1.42	100.38
65-300Hz PWR HARM	10	1.06	5.94	3.38	1.38	40.77
	60	1.02	4.16	2.51	1.08	43.15
	110	0.82	4.28	2.05	1.05	51.43
	160	0.60	7.56	2.51	2.15	85.94
305-2560Hz HIGH FREQ	10	0.59	4.57	1.90	1.08	56.83
	60	0.56	2.91	1.45	0.77	52.84
	110	0.40	2.38	1.13	0.65	57.79
	160	0.33	3.98	1.34	1.14	85.26
5-2560Hz ALL FREQ	10	5.03	23.72	13.01	5.84	44.85
	60	3.06	22.36	11.10	6.29	56.60
	110	2.00	29.32	11.34	8.46	74.61
	160	1.97	56.50	17.04	17.58	103.16

APPENDIX I

DATASET MET009  
IN FRONT OF OPERATOR'S SEAT, CAR #3012

Measurement Setup Code:        Staff:     8     Reference: 11  
   Drawing:  A-1

Vehicle Status:                    Traveling on the Red Line

Measurement Date:                May 19, 1992

Measurement Time:                Start:     10:15:48  
   End:        10:17:33

Number of Samples:                10

Programmed Sample Interval:     5 sec

Actual Sample Interval:         11.7 sec

Frequency Spectrum Parameters

<u>Probe Type:</u>	<u>Wideband</u>	<u>Static</u>
Maximum Frequency (Hz)	2560	100
Minimum Frequency (Hz)	5	0
Spectral Bandwidth (Hz)	5	1

Missing Data: None

<u>Saturated Data - Wideband:</u>	<u>Sensor</u>	<u>Sample</u>	<u>Time (sec)</u>
	Ref	5	47
	Ref	6	59

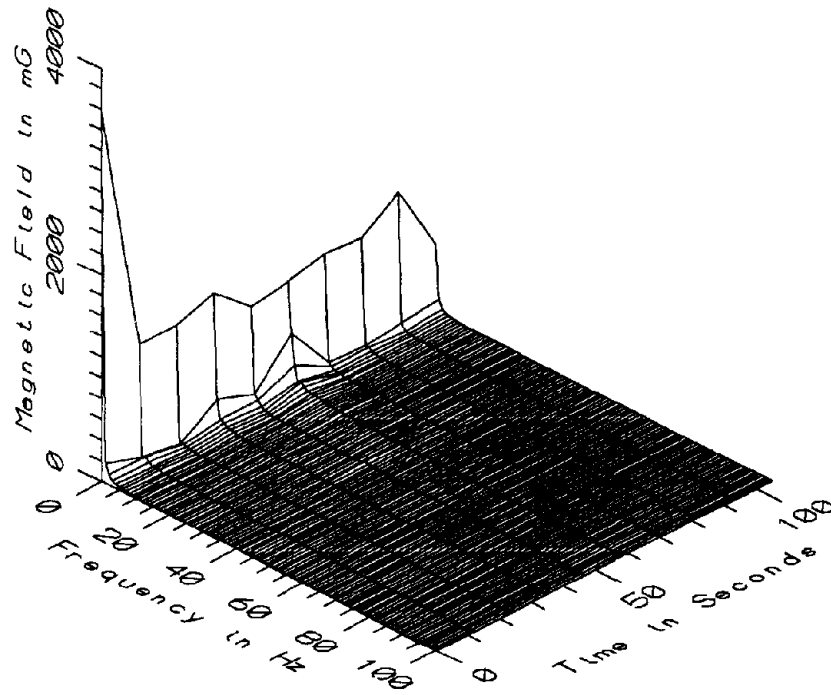

MET009 - 10cm ABOVE FLOOR, IN FRONT OF OPERATOR'S SEAT, CAR 3012

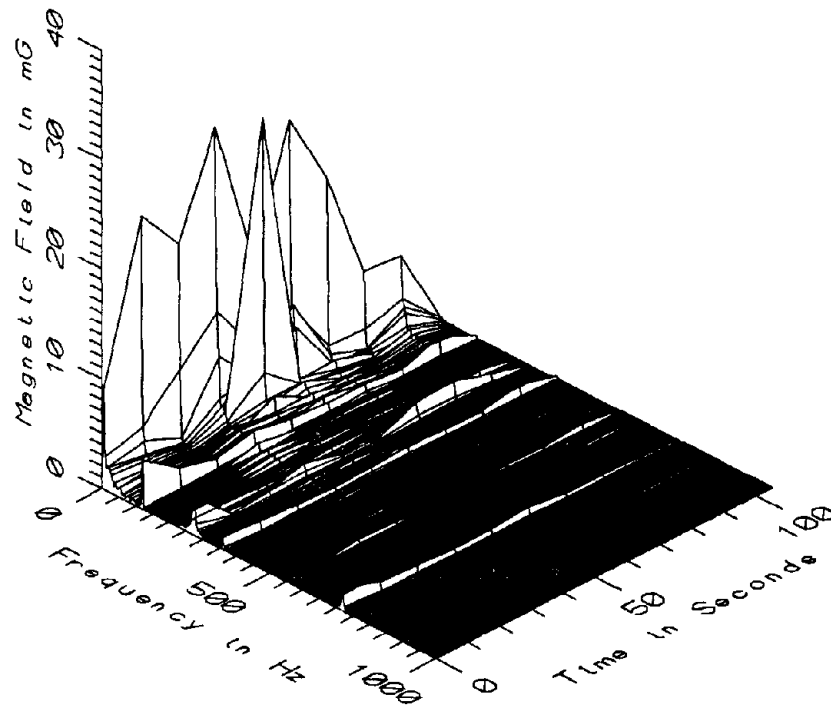

MET009 - 10cm ABOVE FLOOR, IN FRONT OF OPERATOR'S SEAT, CAR 3012

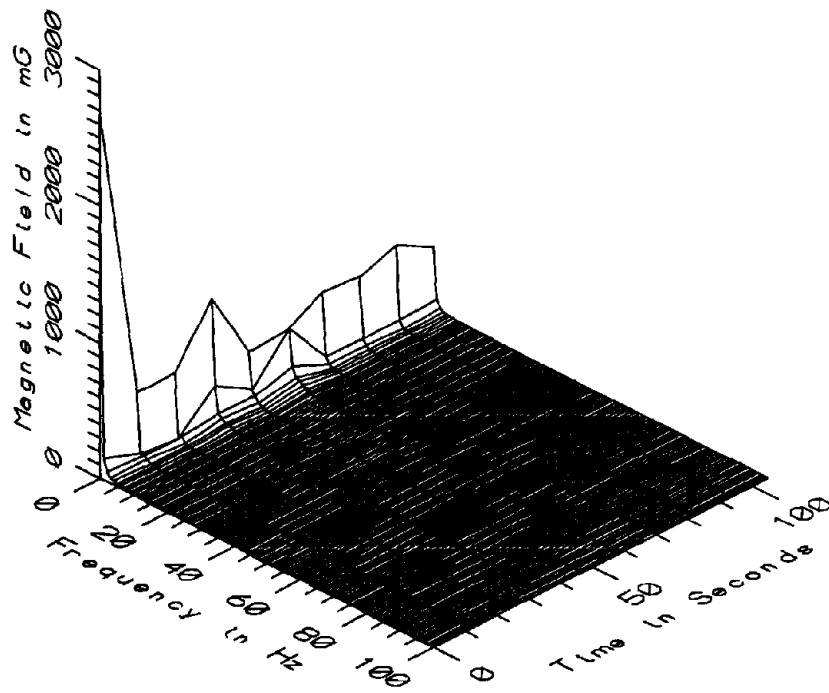

MET009 - 60cm ABOVE FLOOR, IN FRONT OF OPERATOR'S SEAT, CAR 3012

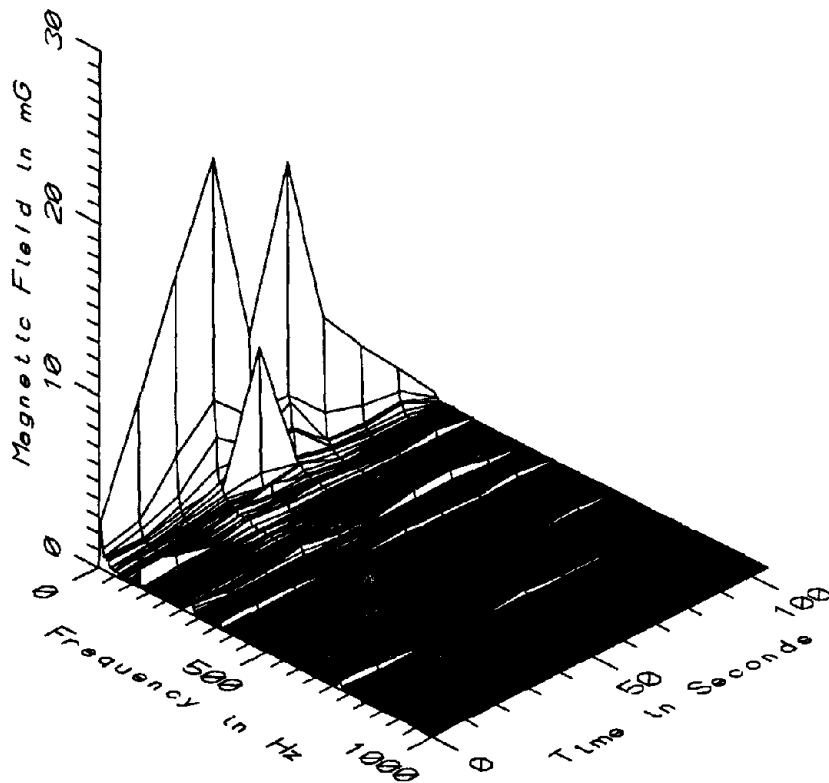

MET009 - 60cm ABOVE FLOOR, IN FRONT OF OPERATOR'S SEAT, CAR 3012

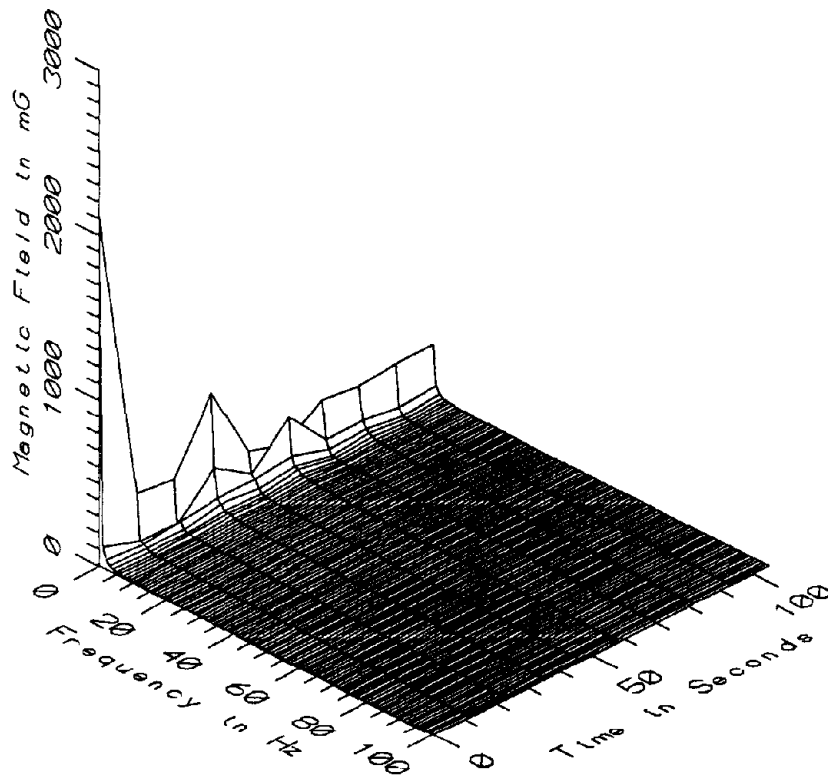

MET009 - 110cm ABOVE FLOOR, IN FRONT OF OPERATOR'S SEAT, CAR 3012

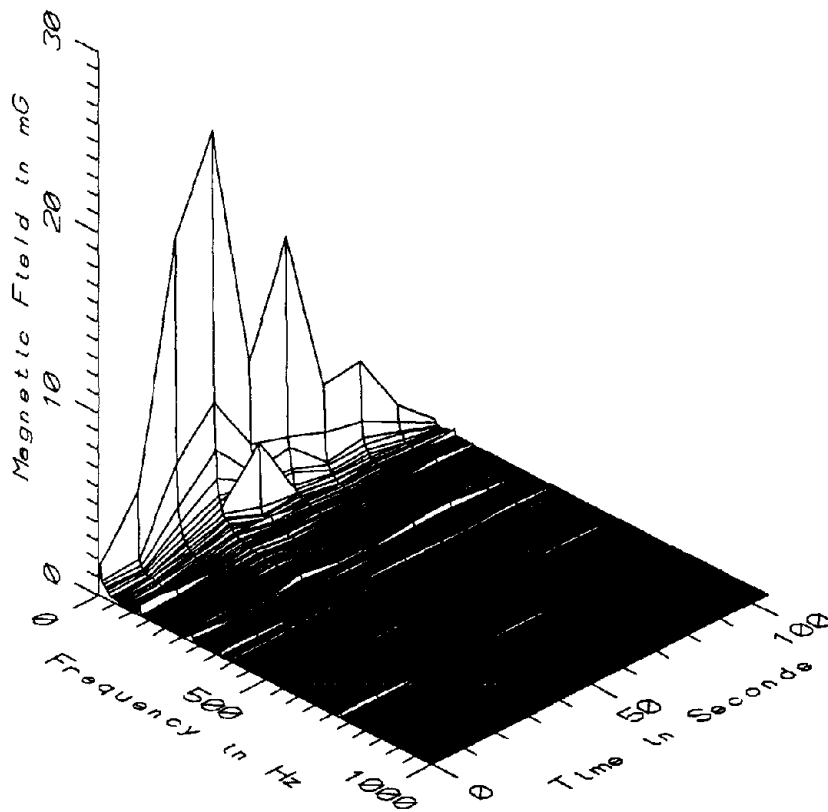

MET009 - 110cm ABOVE FLOOR, IN FRONT OF OPERATOR'S SEAT, CAR 3012



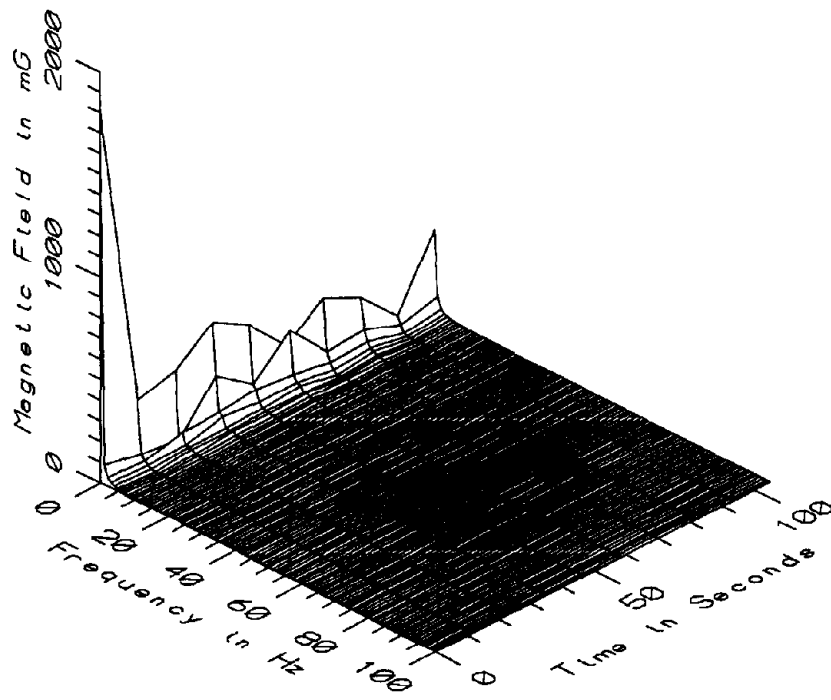

MET009 - 160cm ABOVE FLOOR, IN FRONT OF OPERATOR'S SEAT, CAR 3012

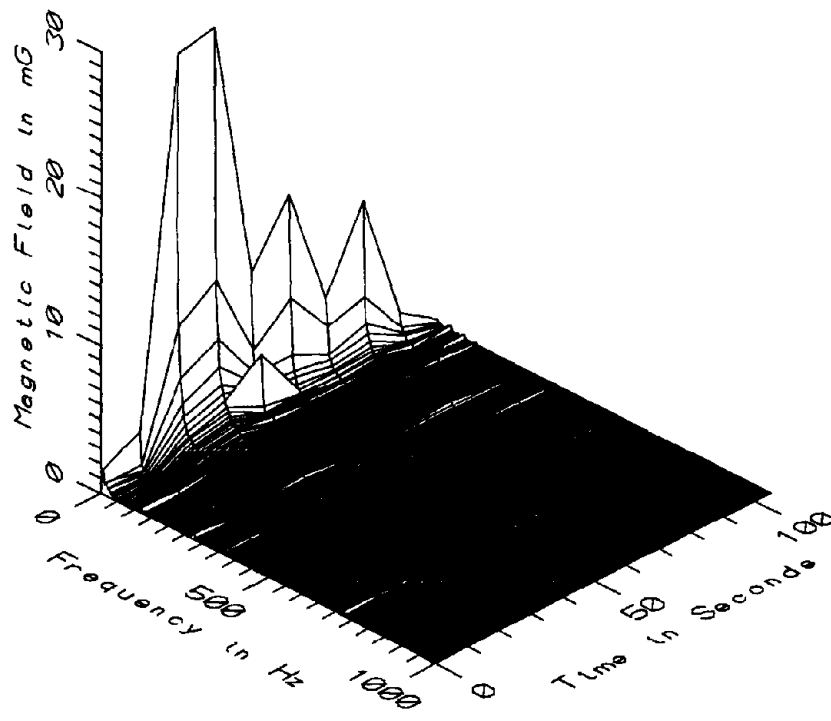

MET009 - 160cm ABOVE FLOOR, IN FRONT OF OPERATOR'S SEAT, CAR 3012

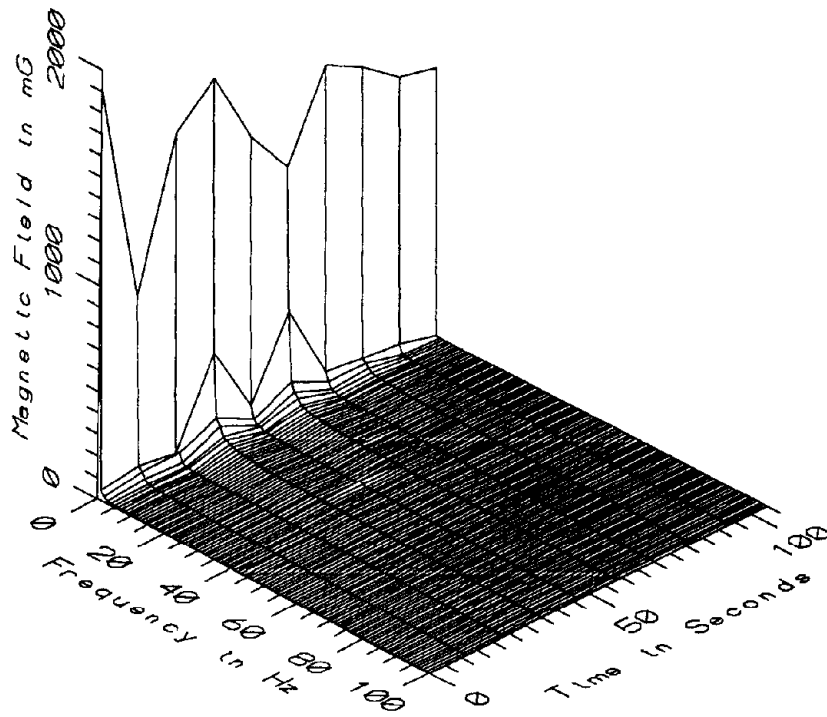

MET009 - REFERENCE PROBE - OPERATOR'S SEAT, CAR 3012

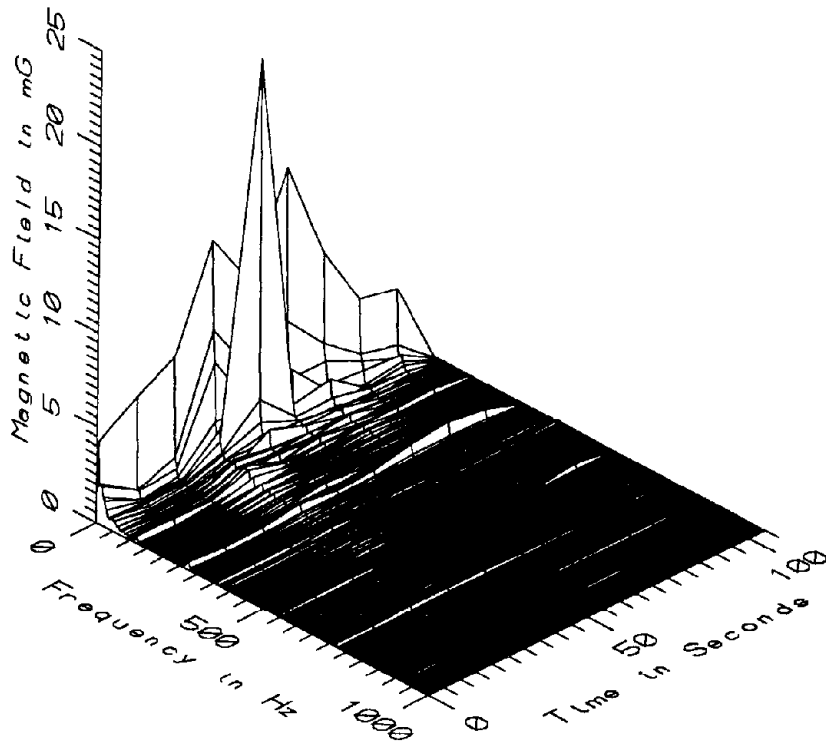

MET009 - REFERENCE PROBE - OPERATOR'S SEAT, CAR 3012

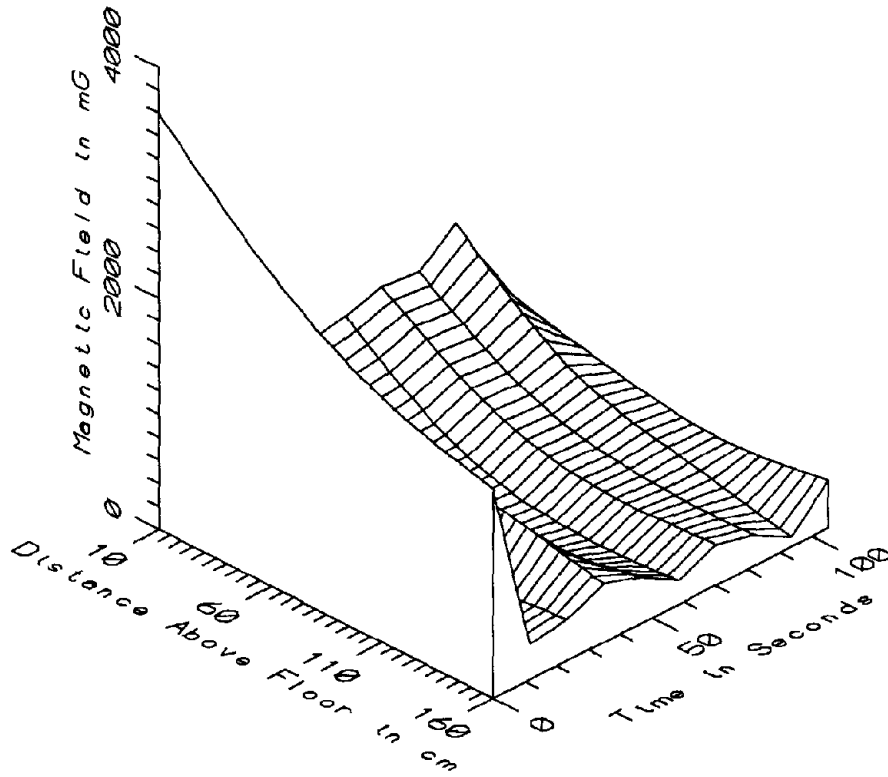

MET009 - IN FRONT OF OPERATOR'S SEAT, CAR 3012 - STATIC

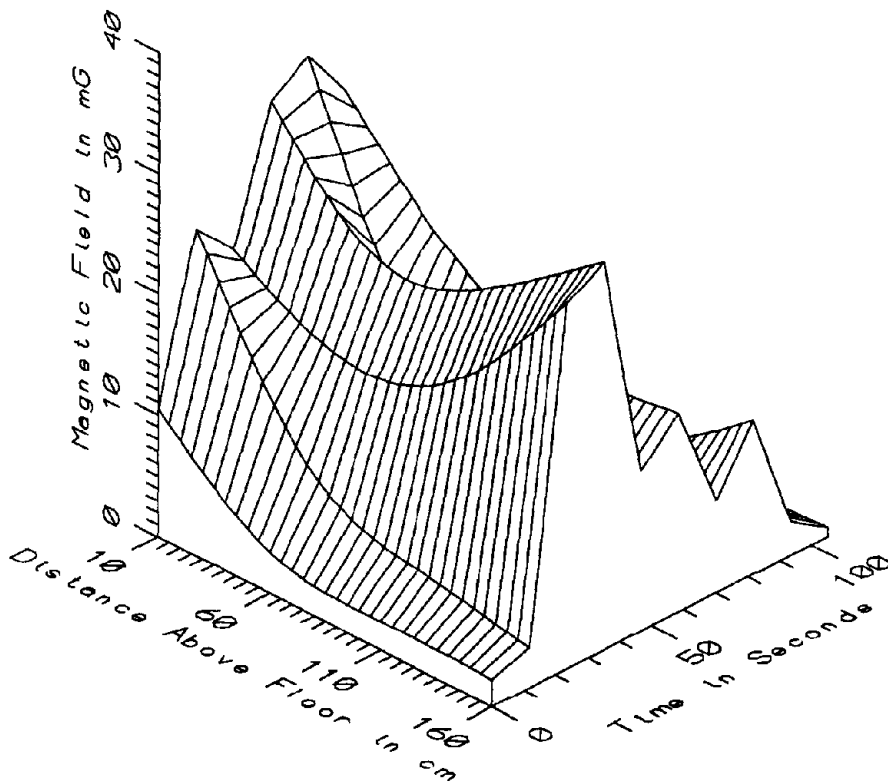

MET009 - IN FRONT OF OPERATOR'S SEAT, CAR 3012 - LOW FREQ, 5-45Hz

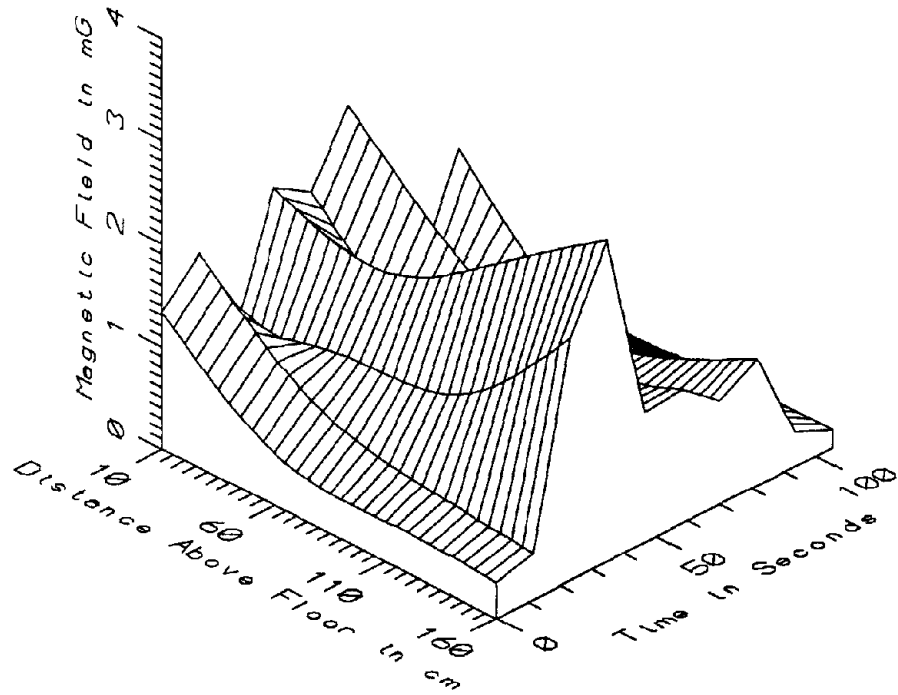

MET009 - IN FRONT OF OPERATOR'S SEAT, CAR 3012 - POWER FREQ, 50-60Hz

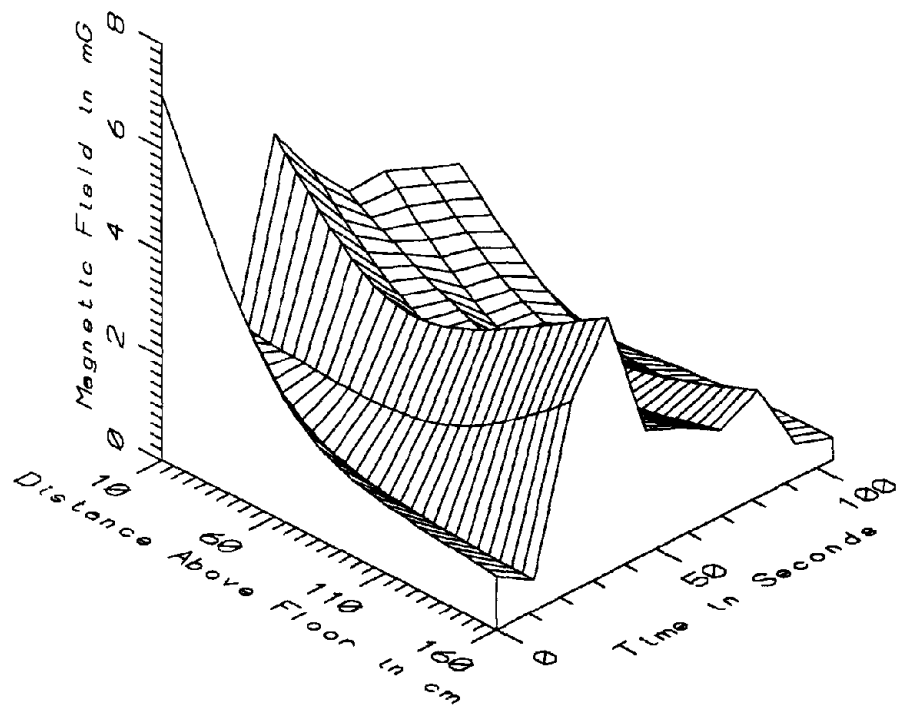

MET009 - IN FRONT OF OPERATOR'S SEAT, CAR 3012 - POWER HARM, 65-300Hz

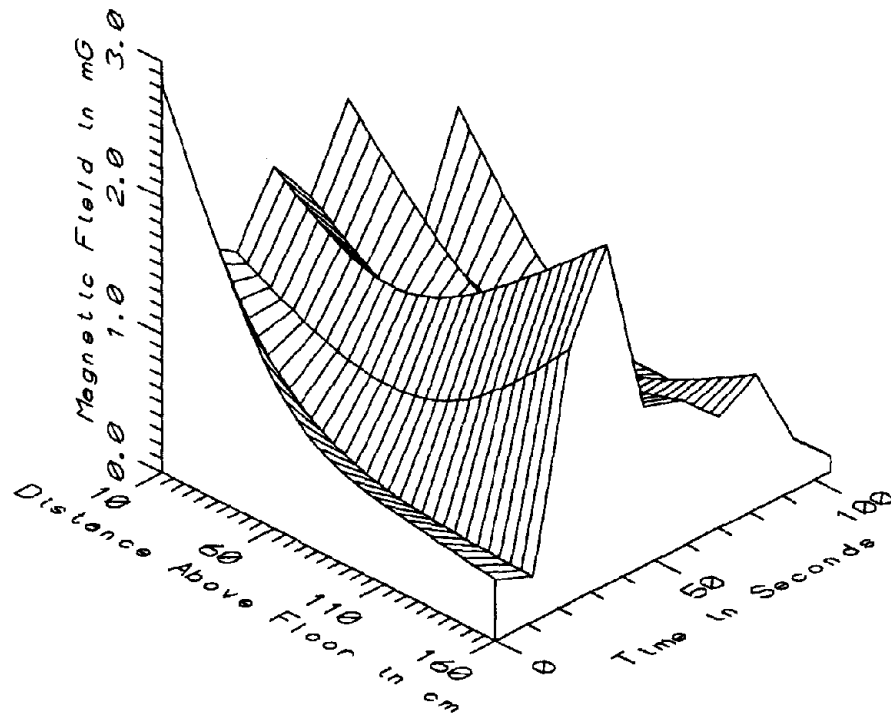

MET009 - IN FRONT OF OPERATOR'S SEAT, CAR 3012 - HIGH FREQ, 305-2560Hz

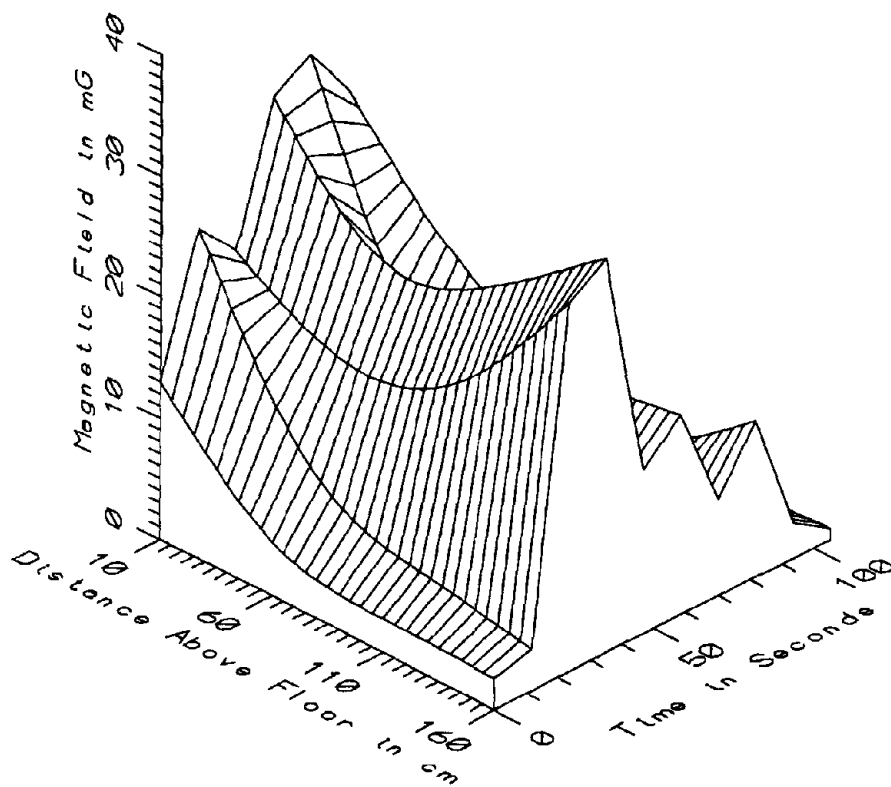

MET009 - IN FRONT OF OPERATOR'S SEAT, CAR 3012 - ALL FREQ, 5-2560Hz

MET009 - IN FRONT OF OPERATOR'S SEAT, CAR #3012		TOTAL OF 10 SAMPLES				
FREQUENCY BAND	HEIGHT ABOVE FLOOR (cm)	MINIMUM MAGNETIC FIELD (mG)	MAXIMUM MAGNETIC FIELD (mG)	AVERAGE MAGNETIC FIELD (mG)	STANDARD DEVIATION (mG)	COEFFICIENT OF VARIATION (%)
STATIC	10	661.86	3589.36	1336.16	813.27	60.87
	60	380.00	2695.17	749.46	699.23	93.30
	110	170.14	2107.86	507.83	579.16	114.05
	160	85.30	1802.29	470.56	482.36	102.51
5-45Hz	10	0.73	33.48	18.59	11.06	59.48
LOW FREQ	60	0.54	22.48	10.38	7.44	71.66
	110	0.44	25.08	9.47	8.11	85.64
	160	0.79	31.74	12.05	11.21	92.98
50-60Hz	10	0.18	2.43	1.32	0.69	52.35
PWR FREQ	60	0.12	1.72	0.83	0.49	58.59
	110	0.17	2.35	0.86	0.62	71.63
	160	0.18	3.12	1.16	0.95	82.11
65-300Hz	10	0.28	7.04	3.40	1.82	53.54
PWR HARM	60	0.18	3.15	1.73	0.86	50.07
	110	0.35	3.61	1.51	0.94	62.44
	160	0.42	4.93	1.94	1.44	74.29
305-2560Hz	10	0.35	2.83	1.49	0.68	45.67
HIGH FREQ	60	0.11	1.37	0.79	0.39	48.53
	110	0.09	1.74	0.72	0.47	65.27
	160	0.12	2.47	0.96	0.73	76.54
5-2560Hz	10	0.87	33.81	19.18	10.90	56.83
ALL FREQ	60	0.59	22.81	10.66	7.40	69.46
	110	0.60	25.50	9.69	8.15	84.10
	160	0.92	32.37	12.33	11.34	91.97

APPENDIX J

DATASET MET010  
AXIAL PROFILE AT REAR OF CAR #3012

Measurement Setup Code:      Staff:    6      Reference: 10  
   Drawing: A-1

Vehicle Status:                    Traveling on the Red Line

Measurement Date:                May 19, 1992

Measurement Time:                Start:    10:18:12  
   End:      10:20:18

Number of Samples:                13

Programmed Sample Interval:    5 sec

Actual Sample Interval:         10.5 sec

Frequency Spectrum Parameters

<u>Probe Type:</u>	<u>Wideband</u>	<u>Static</u>
Maximum Frequency (Hz)	2560	100
Minimum Frequency (Hz)	5	0
Spectral Bandwidth (Hz)	5	1

Missing Data: None

Saturated Data - Wideband:	<u>Sensor</u>	<u>Sample</u>	<u>Time (sec)</u>
	Ref	9	84

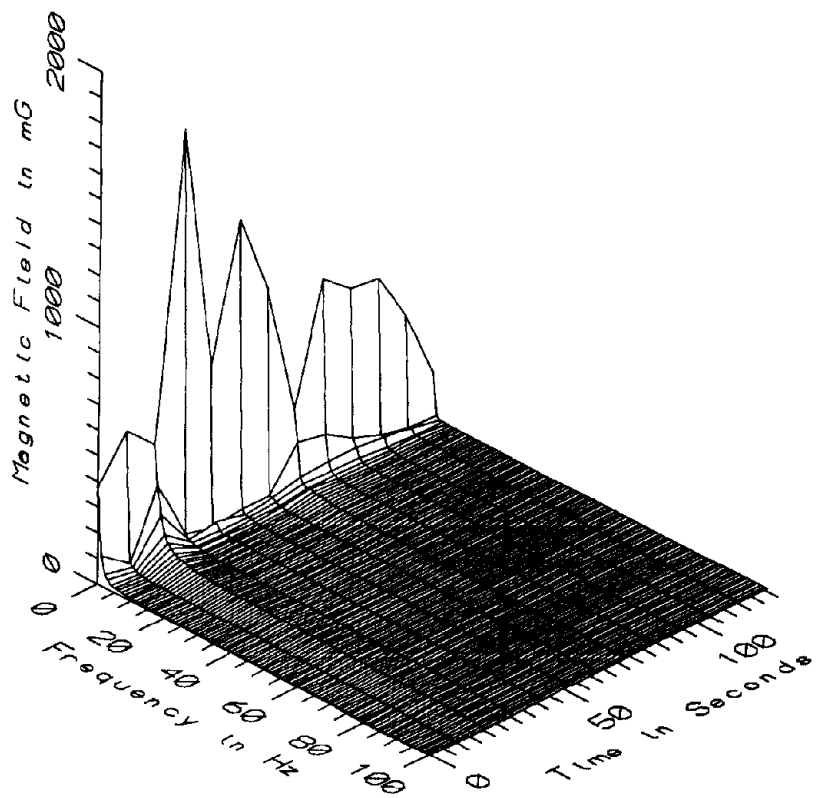

MET010 - -75cm FROM CENTERLINE OF REAR DOORS ALONG AXIS OF CAR 3012

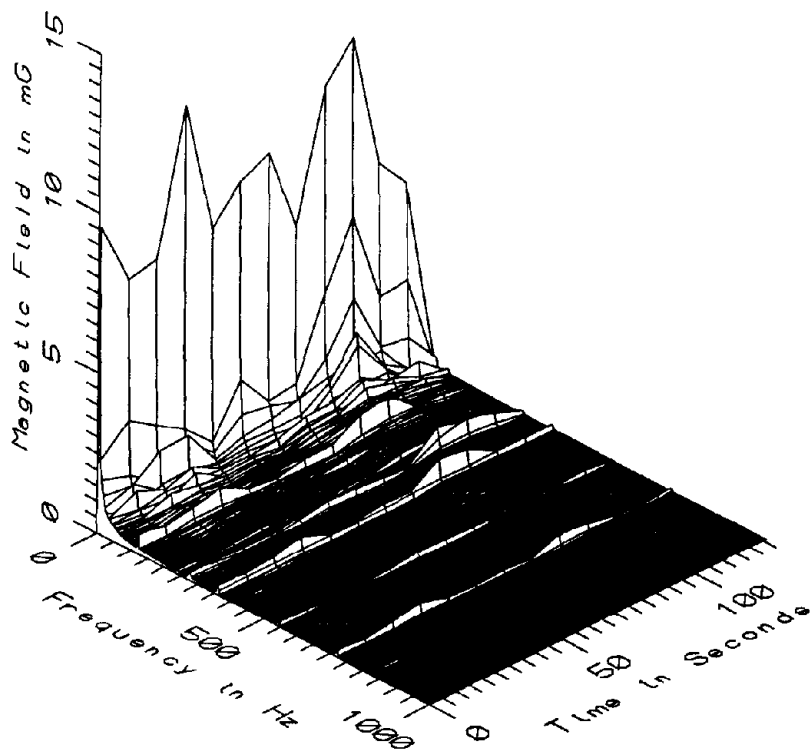

MET010 - -75cm FROM CENTERLINE OF REAR DOORS ALONG AXIS OF CAR 3012



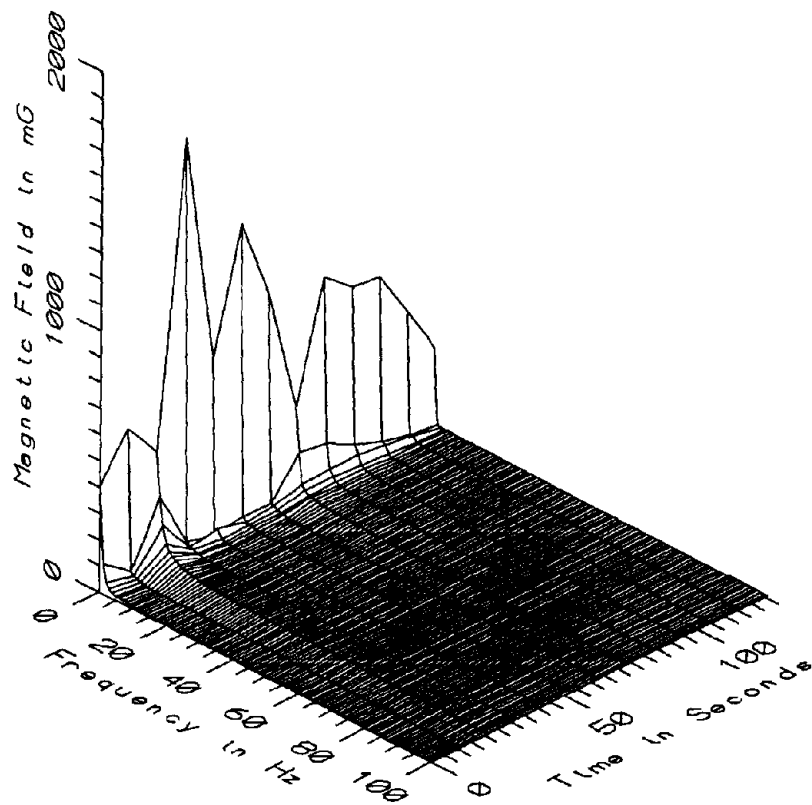

MET010 - -25cm FROM CENTERLINE OF REAR DOORS ALONG AXIS OF CAR 3012

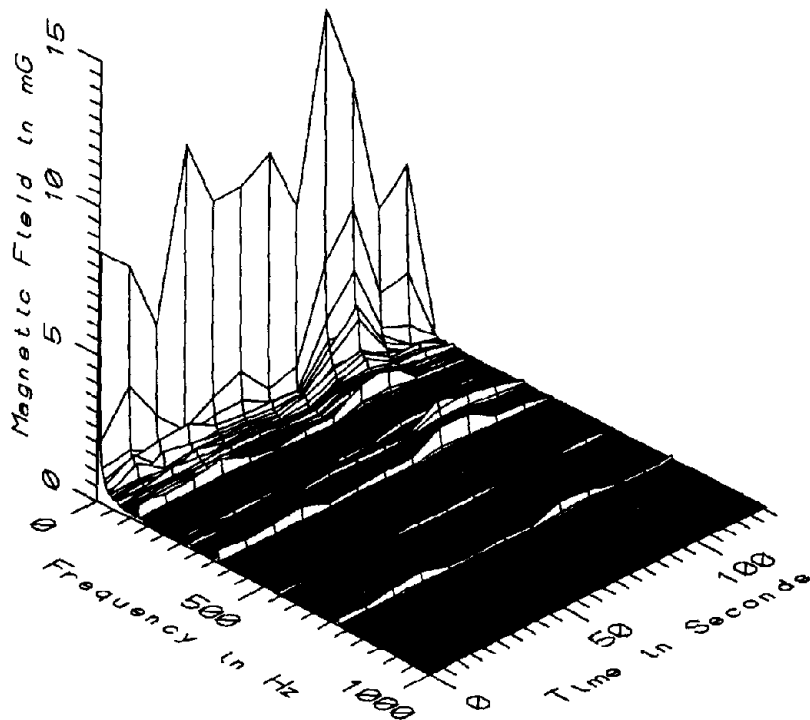

MET010 - -25cm FROM CENTERLINE OF REAR DOORS ALONG AXIS OF CAR 3012

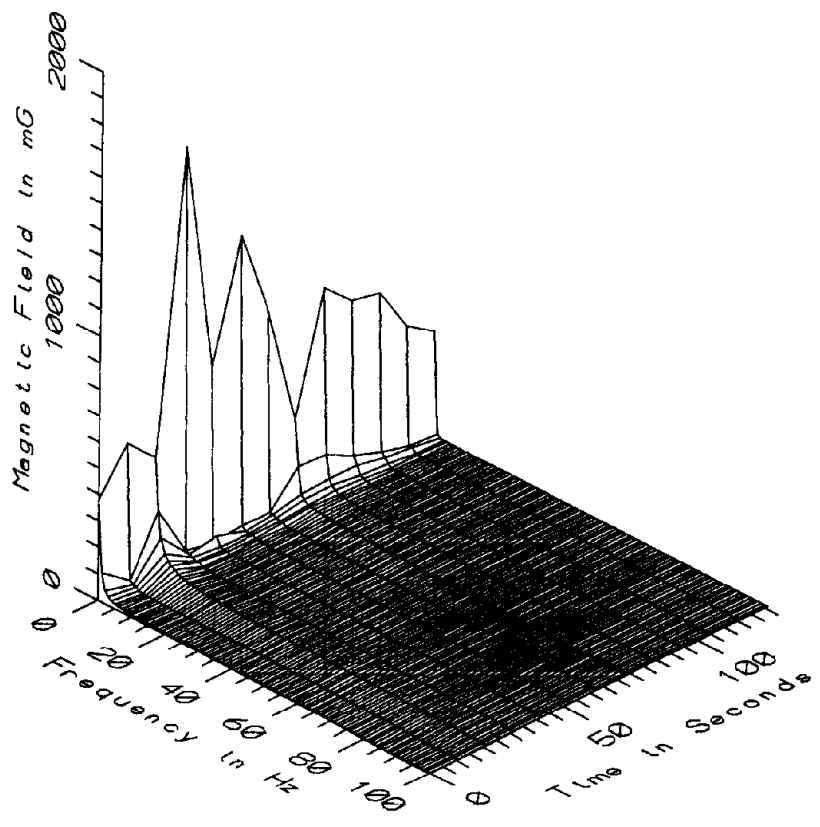

MET010 - 25cm FROM CENTERLINE OF REAR DOORS ALONG AXIS OF CAR 3012

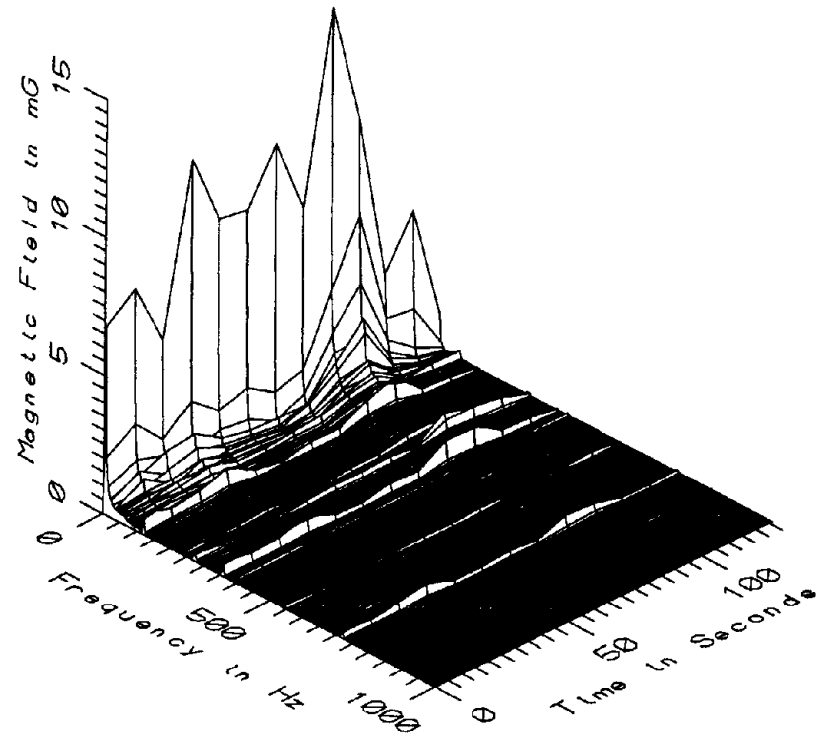

MET010 - 25cm FROM CENTERLINE OF REAR DOORS ALONG AXIS OF CAR 3012

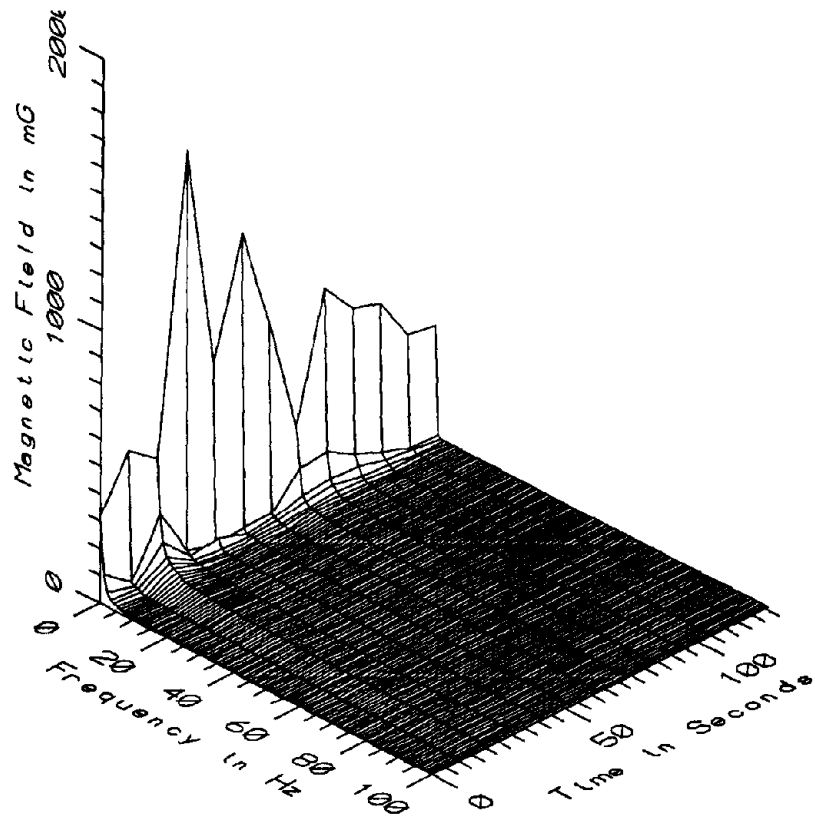

MET010 - 75cm FROM CENTERLINE OF REAR DOORS ALONG AXIS OF CAR 3012

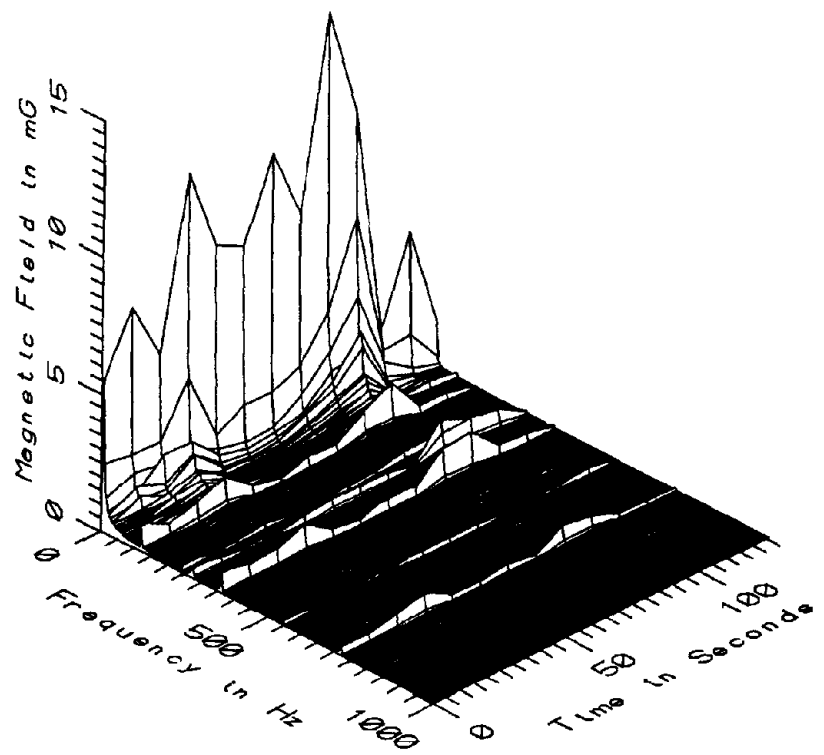

MET010 - 75cm FROM CENTERLINE OF REAR DOORS ALONG AXIS OF CAR 3012

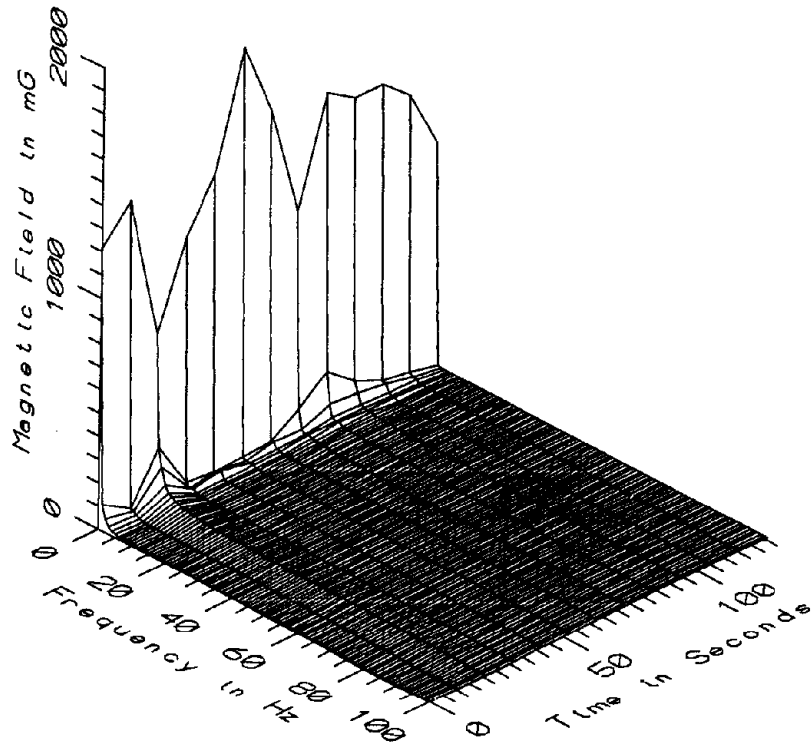

MET010 - REFERENCE PROBE - WINDOW SEAT AT REAR OF CAR 3012

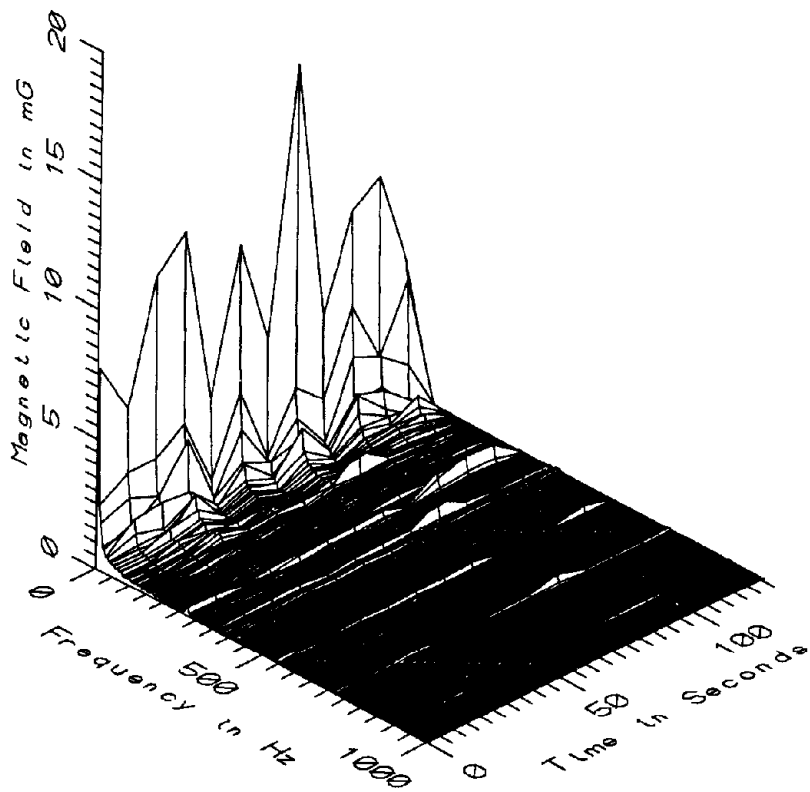

MET010 - REFERENCE PROBE - WINDOW SEAT AT REAR OF CAR 3012

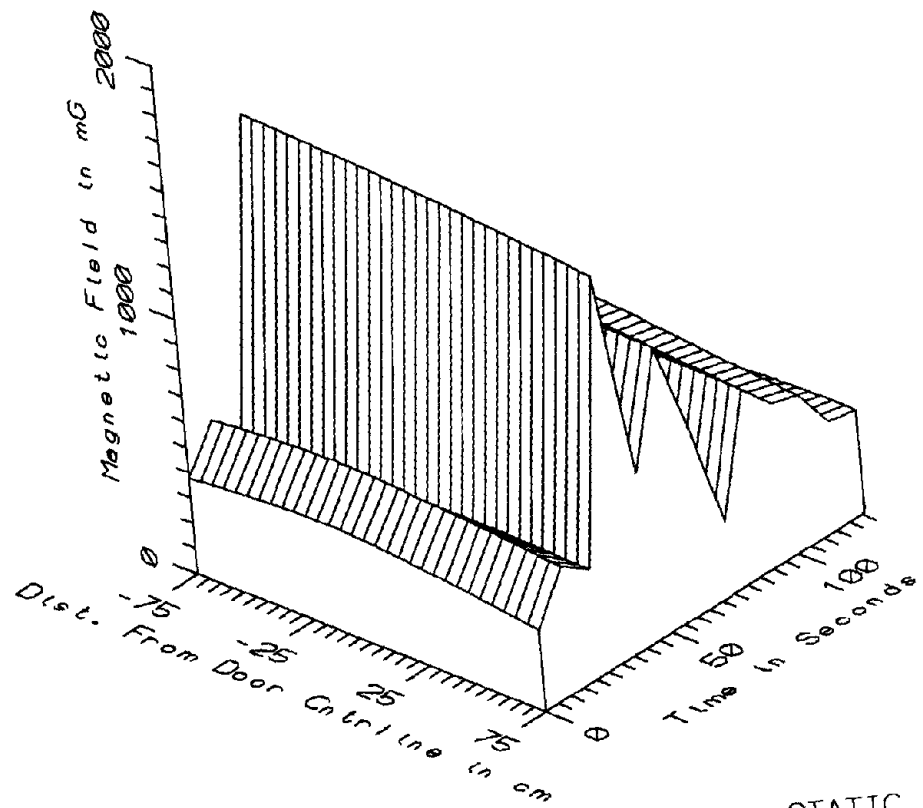

MET010 - AXIAL PROFILE AT REAR OF CAR 3012 - STATIC

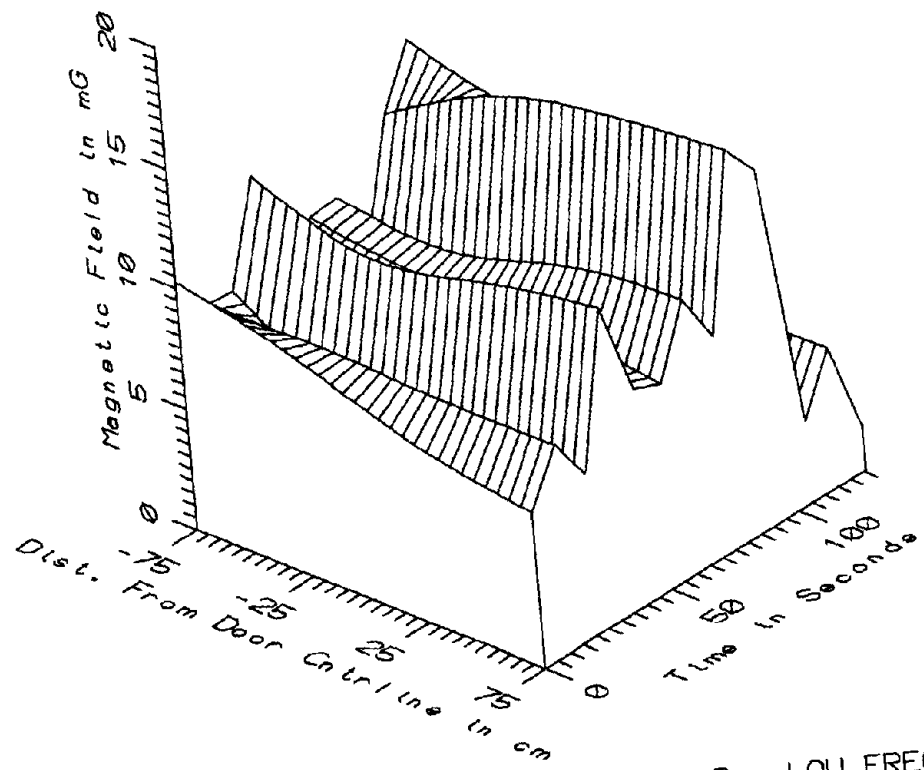

MET010 - AXIAL PROFILE AT REAR OF CAR 3012 - LOW FREQ. 5-45Hz

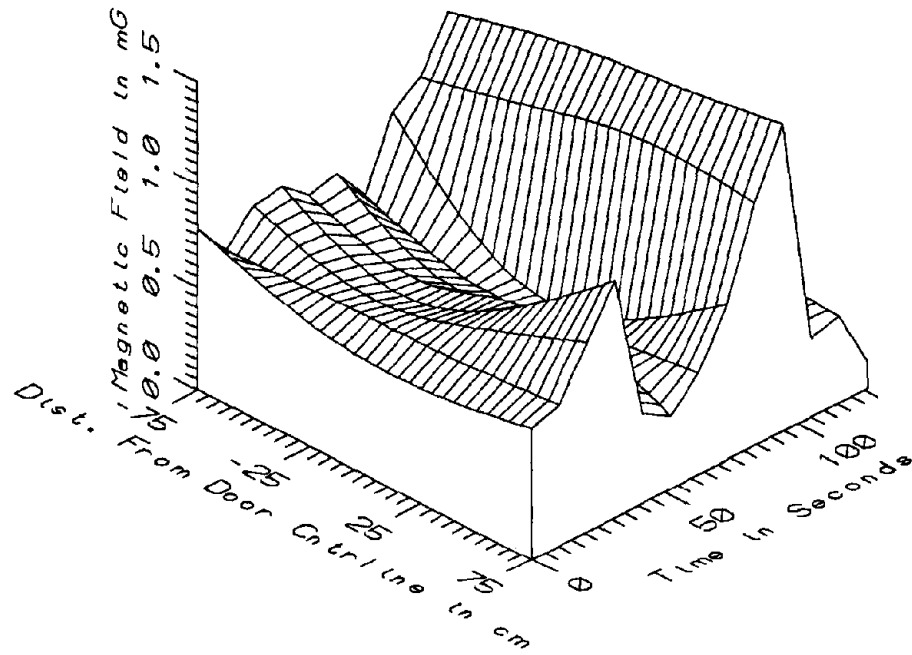

MET010 - AXIAL PROFILE AT REAR OF CAR 3012 - POWER FREQ, 50-60Hz

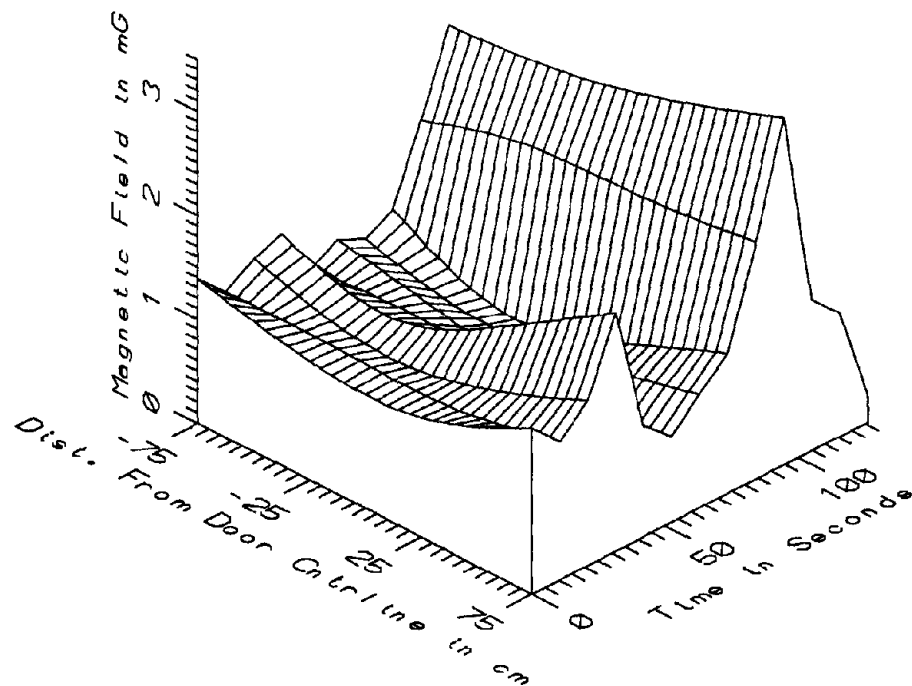

MET010 - AXIAL PROFILE AT REAR OF CAR 3012 - POWER HARM, 65-300Hz

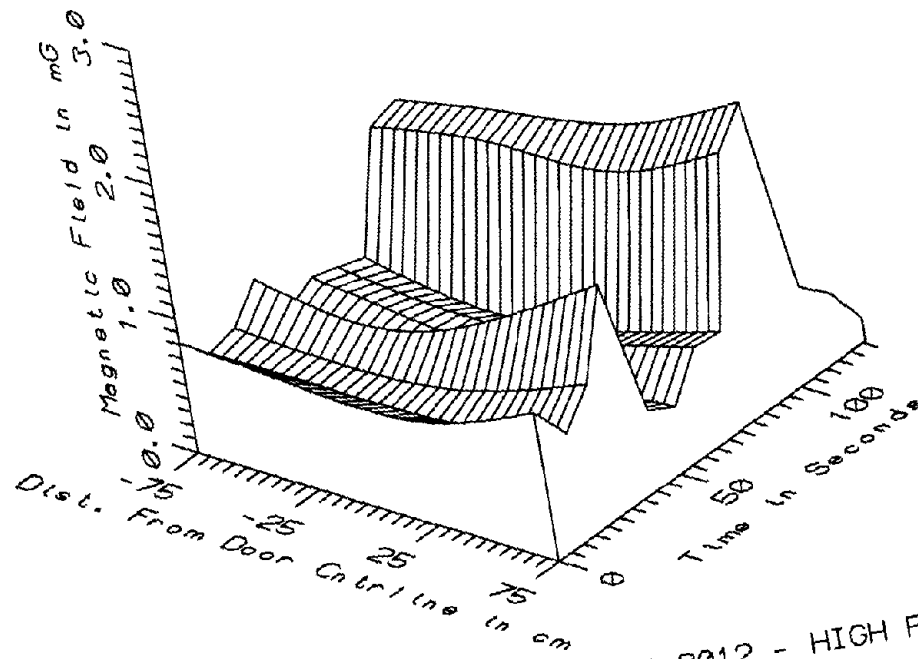

MET010 - AXIAL PROFILE AT REAR OF CAR 3012 - HIGH FREQ. 305-2560Hz

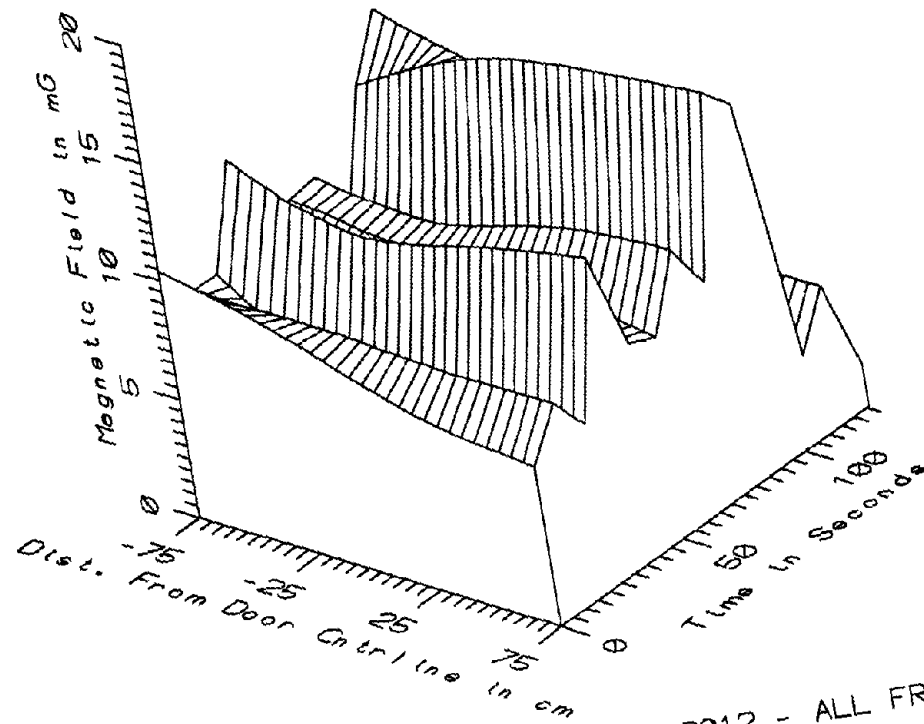

MET010 - AXIAL PROFILE AT REAR OF CAR 3012 - ALL FREQ. 5-2560Hz

MET010 - AXIAL PROFILE AT REAR OF CAR 3012		TOTAL OF 13 SAMPLES				
FREQUENCY BAND	DIST ALONG STAFF (cm)	MINIMUM MAGNETIC FIELD (mG)	MAXIMUM MAGNETIC FIELD (mG)	AVERAGE MAGNETIC FIELD (mG)	STANDARD DEVIATION (mG)	COEFFICIENT OF VARIATION (%)
STATIC	-75	172.61	1615.68	660.35	380.94	57.69
	-25	296.89	1590.22	687.24	357.60	52.03
	25	328.01	1557.72	673.14	341.68	50.76
	75	291.39	1512.39	644.09	339.99	52.79
5-45HZ	-75	0.75	14.18	8.98	3.25	36.20
LOW FREQ	-25	0.76	14.43	8.46	3.40	40.24
	25	1.30	15.55	8.54	3.75	43.94
	75	1.77	16.06	8.68	4.14	47.74
50-60HZ	-75	0.20	1.22	0.75	0.27	35.40
PWR FREQ	-25	0.09	1.36	0.61	0.32	52.46
	25	0.19	1.42	0.66	0.33	49.70
	75	0.13	1.49	0.69	0.39	56.71
65-300HZ	-75	0.19	2.61	1.30	0.58	44.69
PWR HARM	-25	0.25	2.71	1.16	0.64	54.91
	25	0.36	2.97	1.23	0.68	55.31
	75	0.26	3.34	1.51	0.77	51.13
305-2560HZ	-75	0.22	1.40	0.72	0.34	47.92
HIGH FREQ	-25	0.15	1.58	0.69	0.42	60.65
	25	0.17	1.75	0.74	0.46	62.51
	75	0.18	2.19	0.98	0.60	61.78
5-2560HZ	-75	0.83	14.53	9.14	3.30	36.08
ALL FREQ	-25	0.82	14.70	8.60	3.47	40.29
	25	1.37	15.82	8.70	3.81	43.82
	75	1.81	16.38	8.92	4.22	47.29



APPENDIX K

DATASET MET011  
TRANSVERSE PROFILE AT REAR OF CAR #3012

Measurement Setup Code:        Staff:     7     Reference: 10  
   Drawing:  A-1

Vehicle Status:                Traveling on the Red Line

Measurement Date:              May 19, 1992

Measurement Time:              Start:     10:20:38  
   End:        10:22:13

Number of Samples:              10

Programmed Sample Interval:    5 sec

Actual Sample Interval:        10.5 sec

Frequency Spectrum Parameters

<u>Probe Type:</u>	<u>Wideband</u>	<u>Static</u>
Maximum Frequency (Hz)	2560	100
Minimum Frequency (Hz)	5	0
Spectral Bandwidth (Hz)	5	1

Missing Data: None

Saturated Data: None

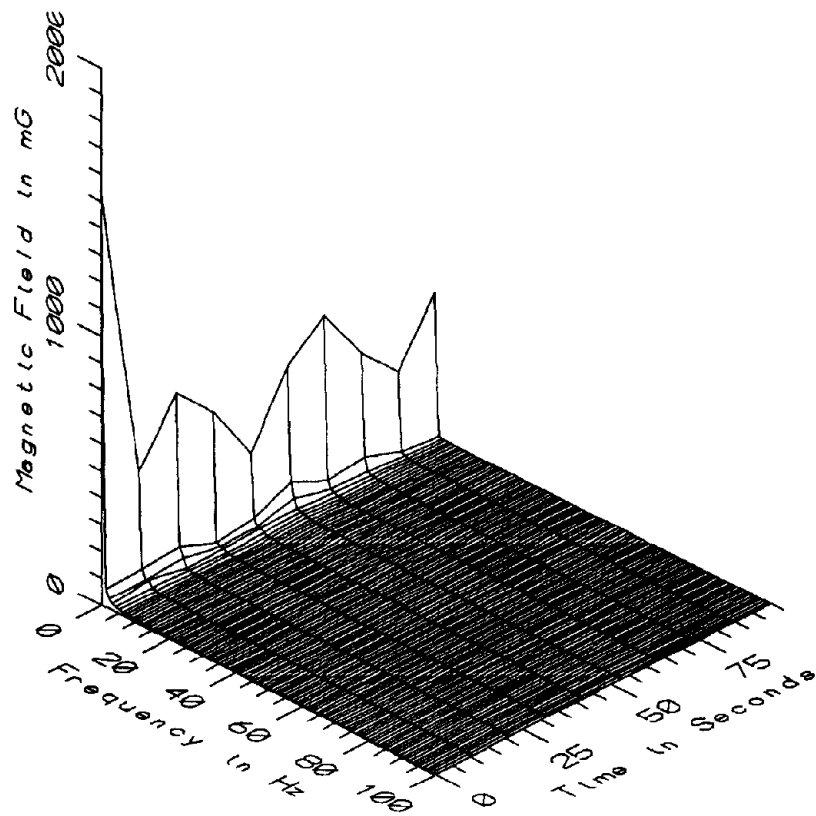

MET011 - -75cm FROM CAR CENTERLINE, REAR OF CAR 3012

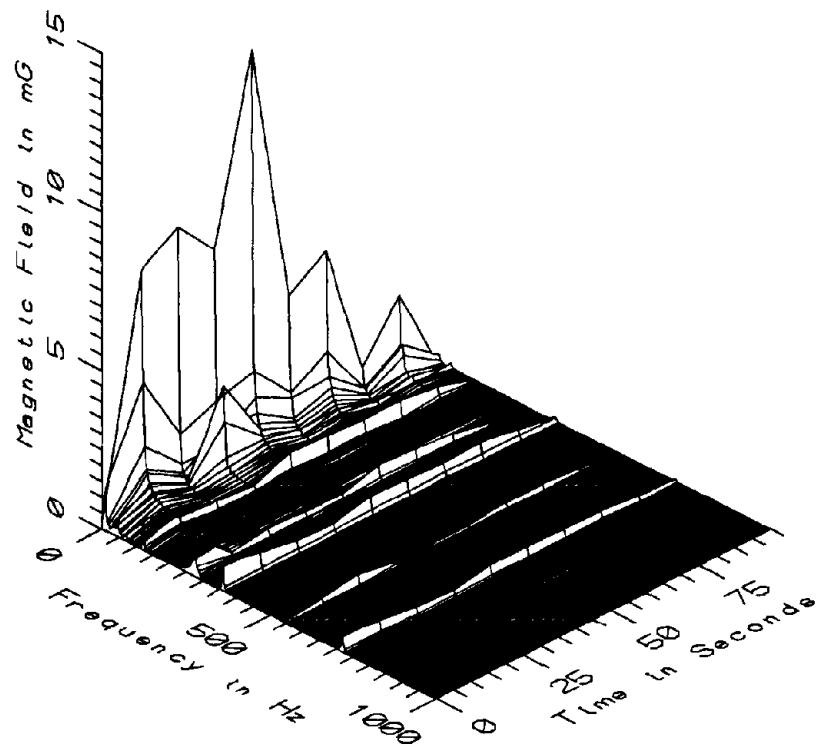

MET011 - -75cm FROM CAR CENTERLINE, REAR OF CAR 3012

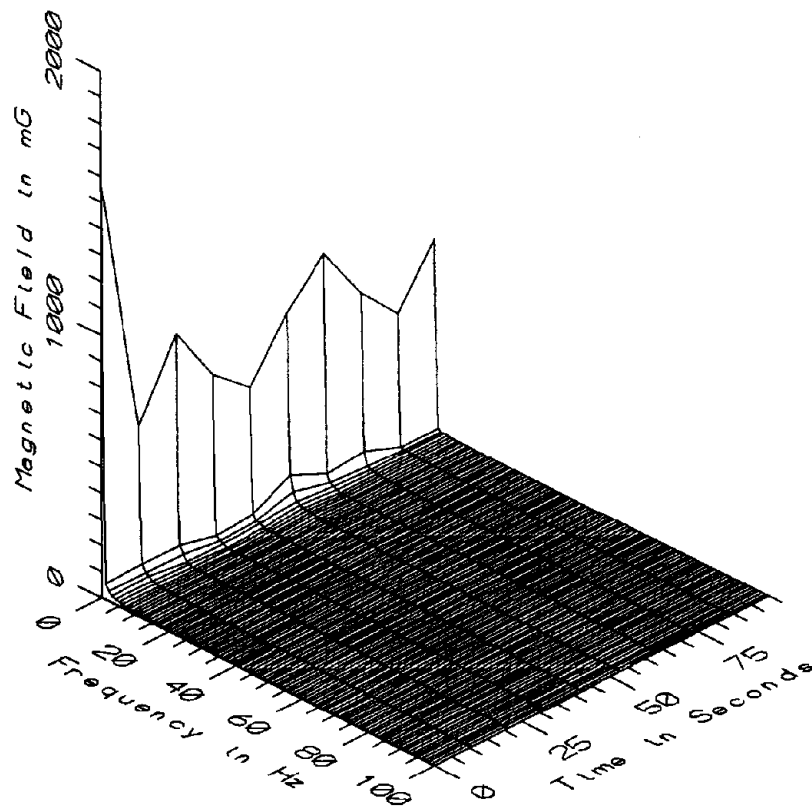

MET011 - -25cm FROM CAR CENTERLINE, REAR OF CAR 3012

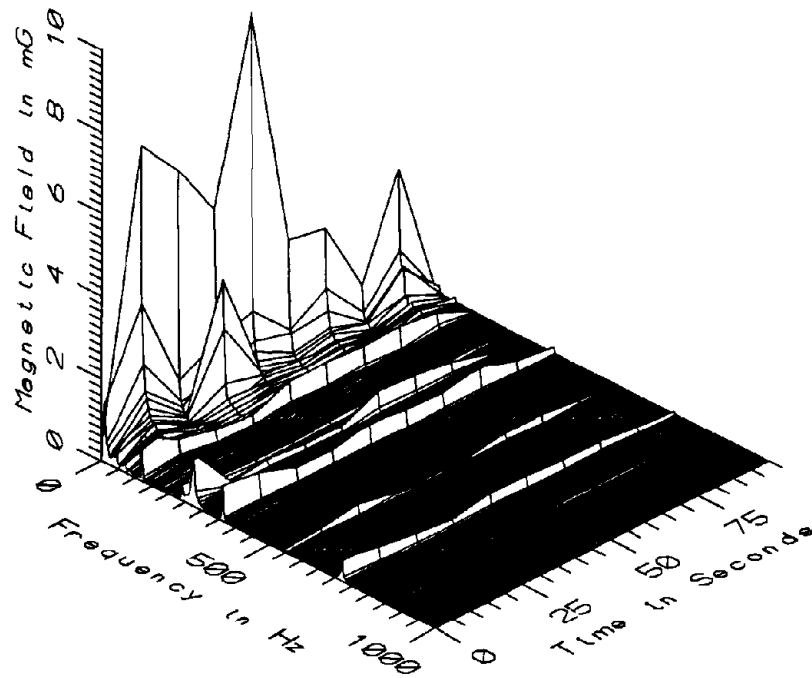

MET011 - -25cm FROM CAR CENTERLINE, REAR OF CAR 3012

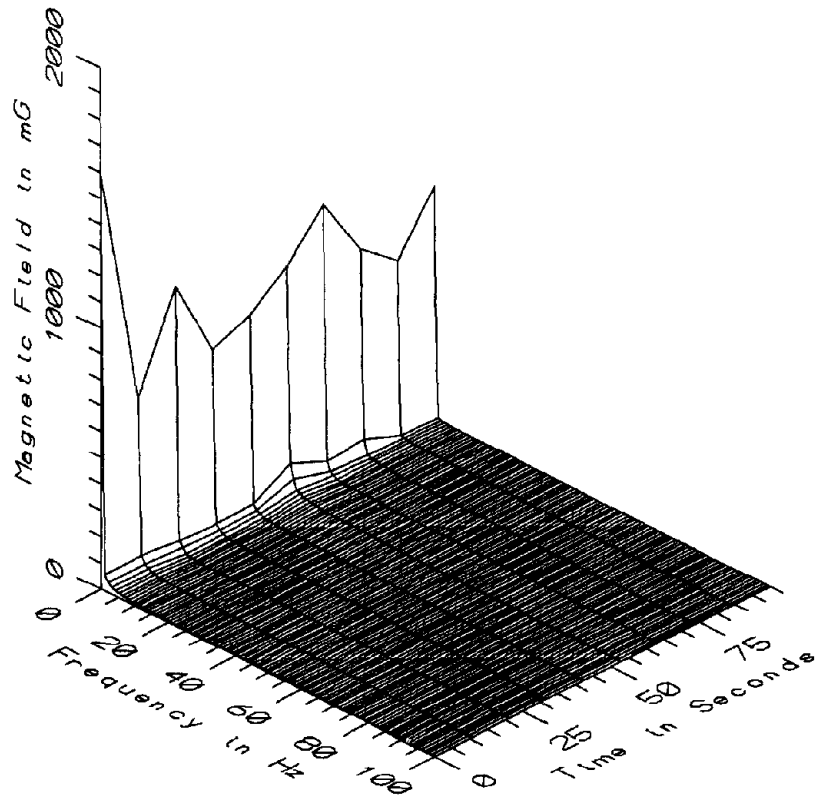

MET011 - 25cm FROM CAR CENTERLINE, REAR OF CAR 3012

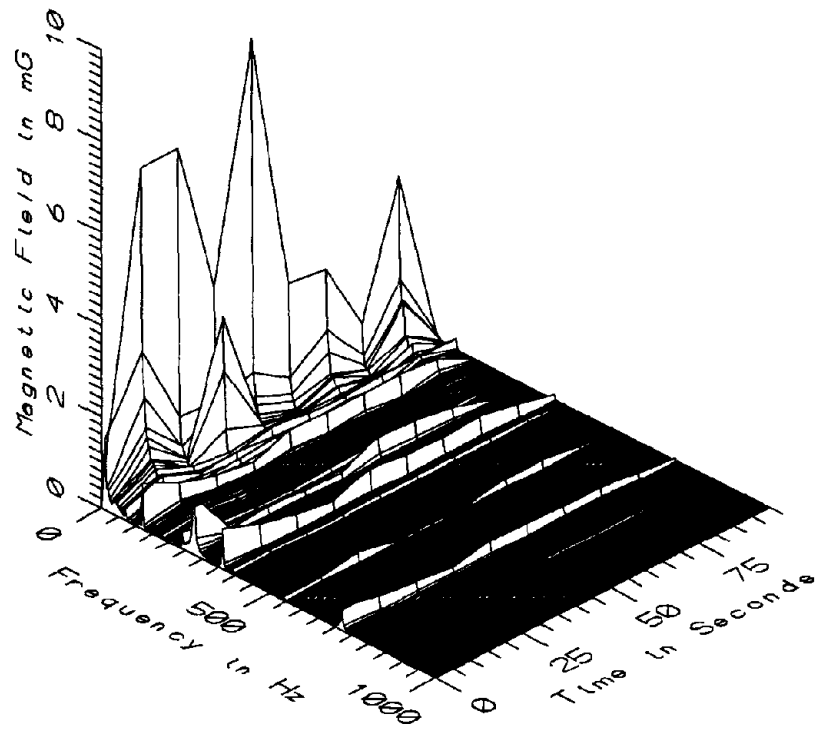

MET011 - 25cm FROM CAR CENTERLINE, REAR OF CAR 3012

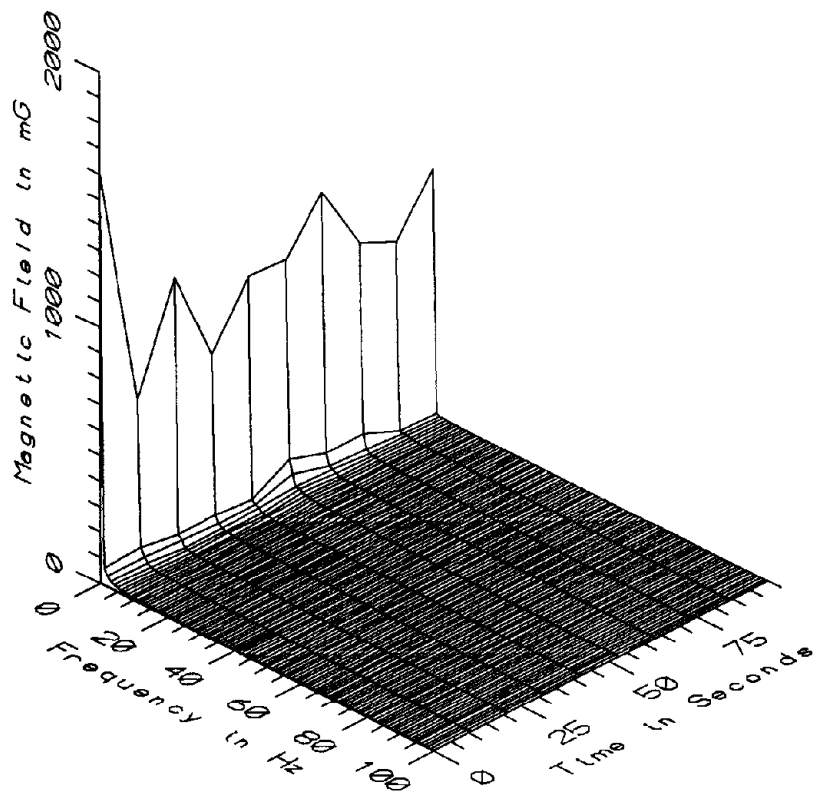

MET011 - 75cm FROM CAR CENTERLINE, REAR OF CAR 3012

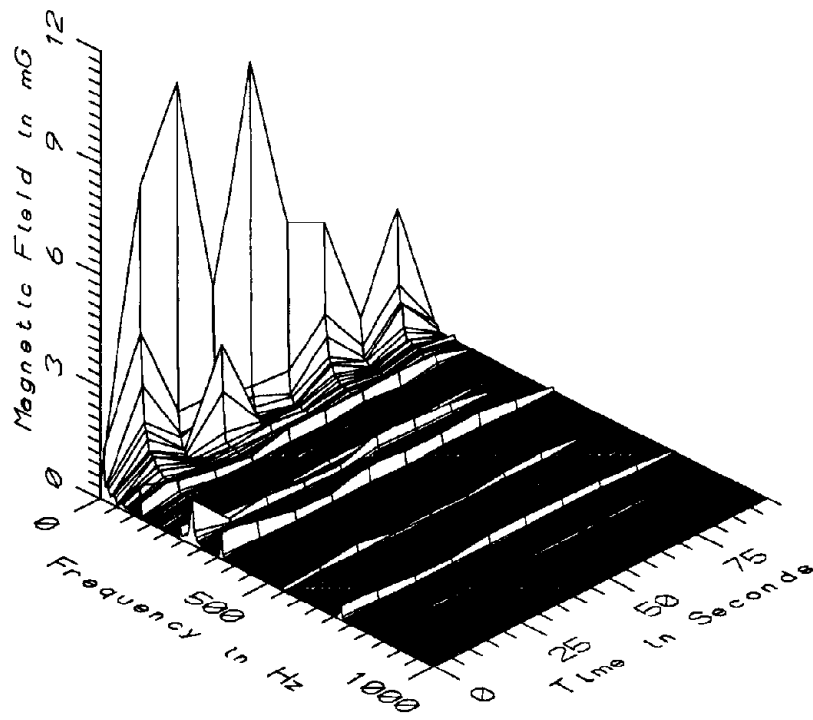

MET011 - 75cm FROM CAR CENTERLINE, REAR OF CAR 3012

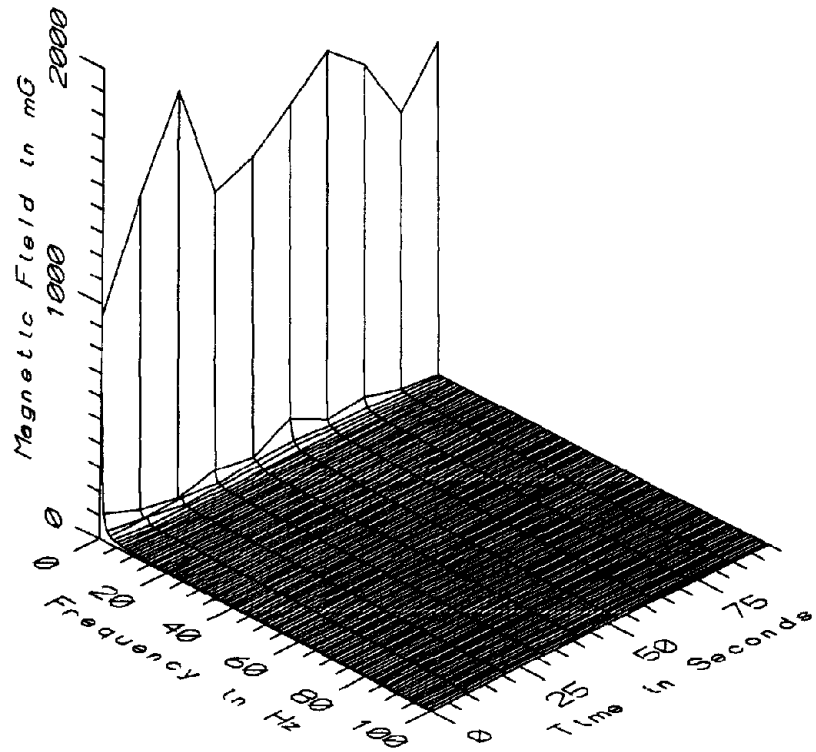

MET011 - REFERENCE PROBE - WINDOW SEAT AT REAR OF CAR 3012

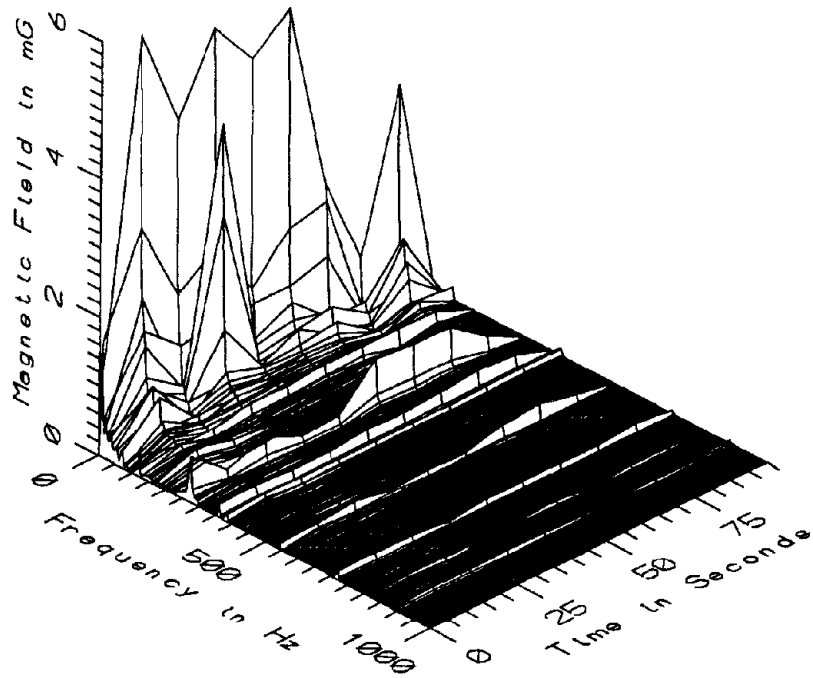

MET011 - REFERENCE PROBE - WINDOW SEAT AT REAR OF CAR 3012

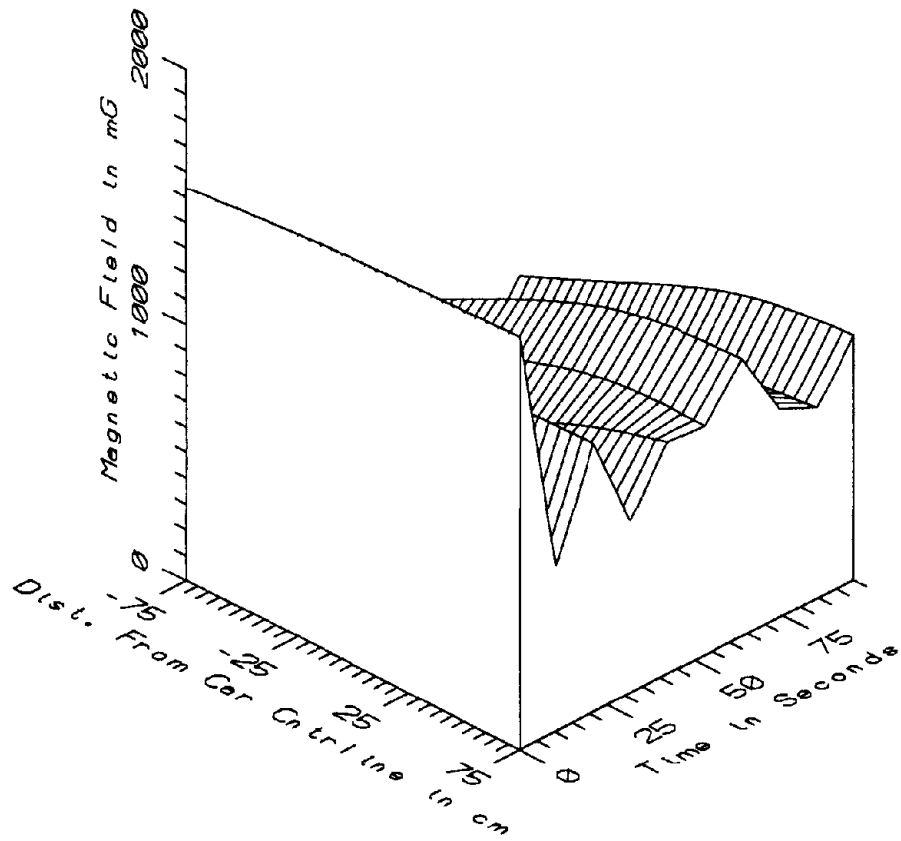

MET011 - TRANSVERSE PROFILE AT REAR OF CAR 3012 - STATIC

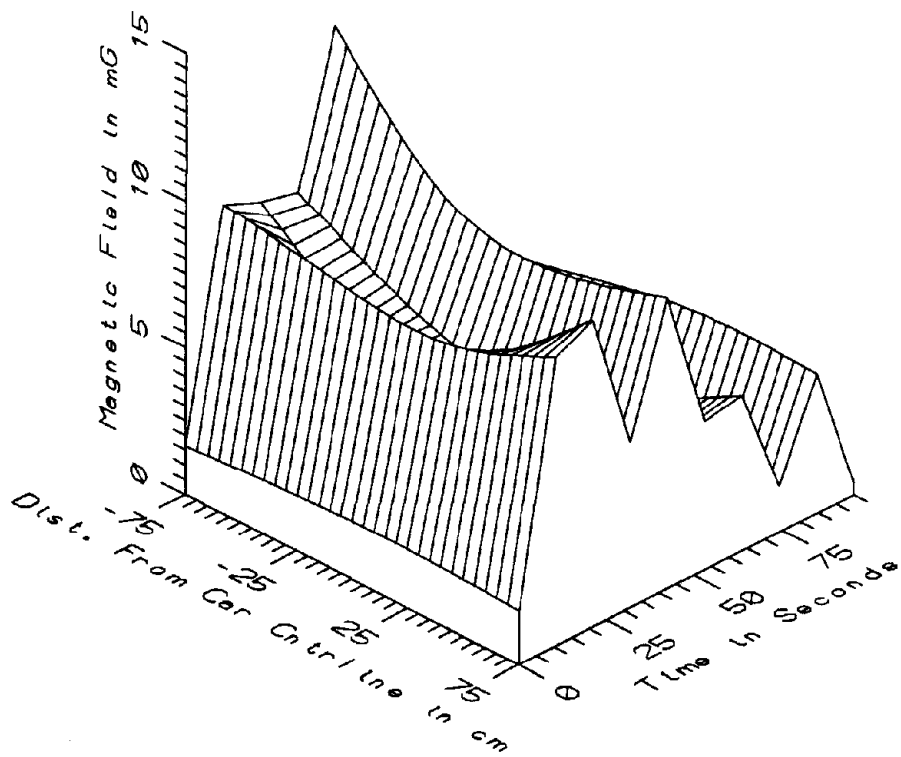

MET011 - TRANSVERSE PROFILE AT REAR OF CAR 3012 - LOW FREQ, 5-45Hz

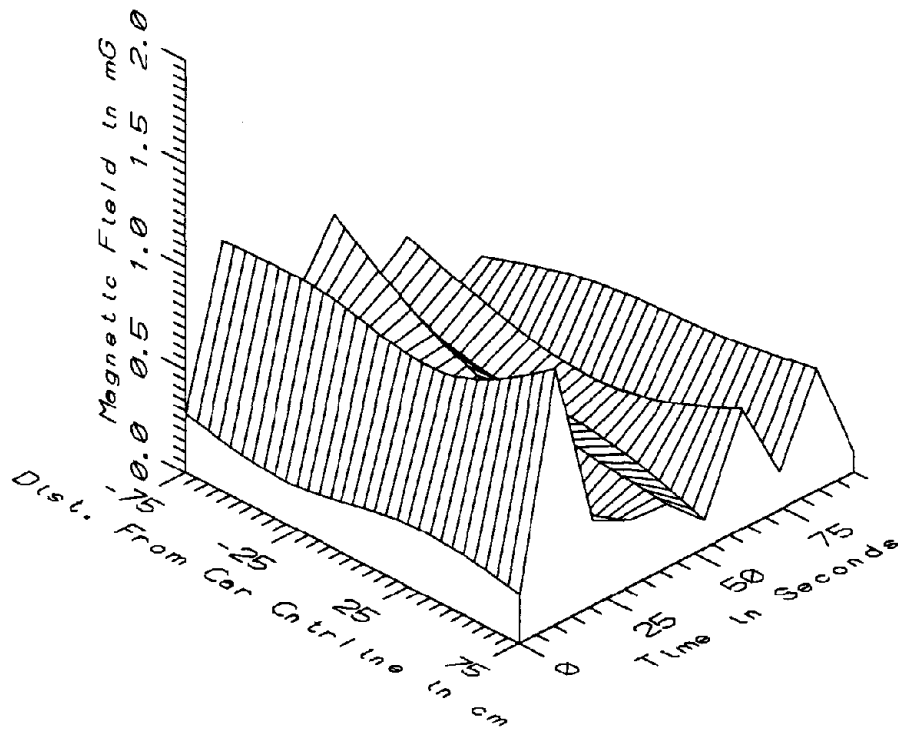

MET011 - TRANSVERSE PROFILE AT REAR OF CAR 3012 - POWER FREQ, 50-60Hz

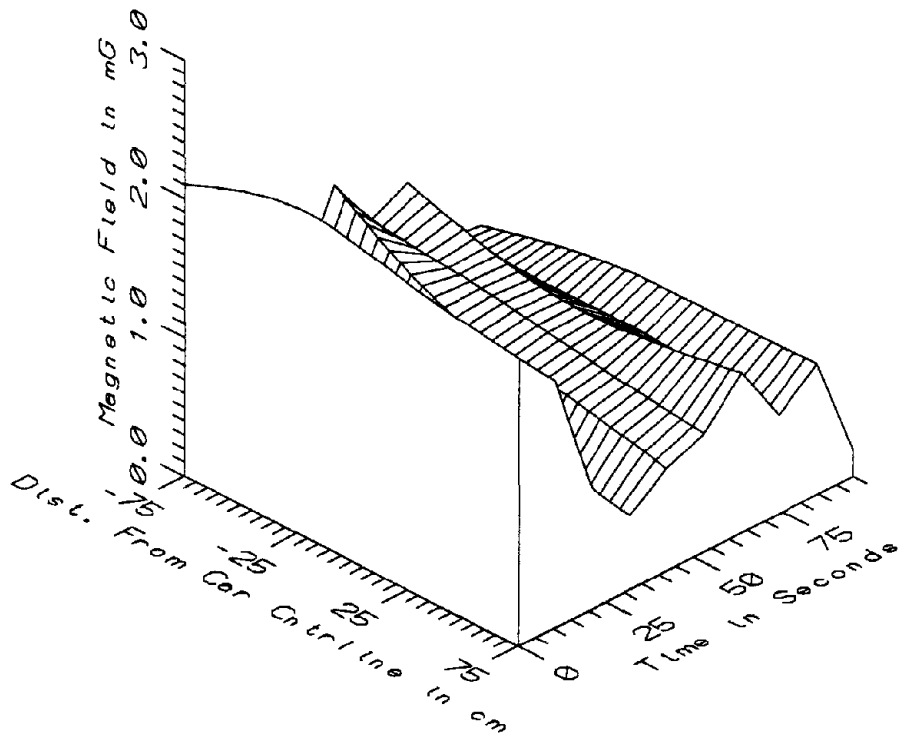

MET011 - TRANSVERSE PROFILE AT REAR OF CAR 3012 - POWER HARM, 65-300Hz



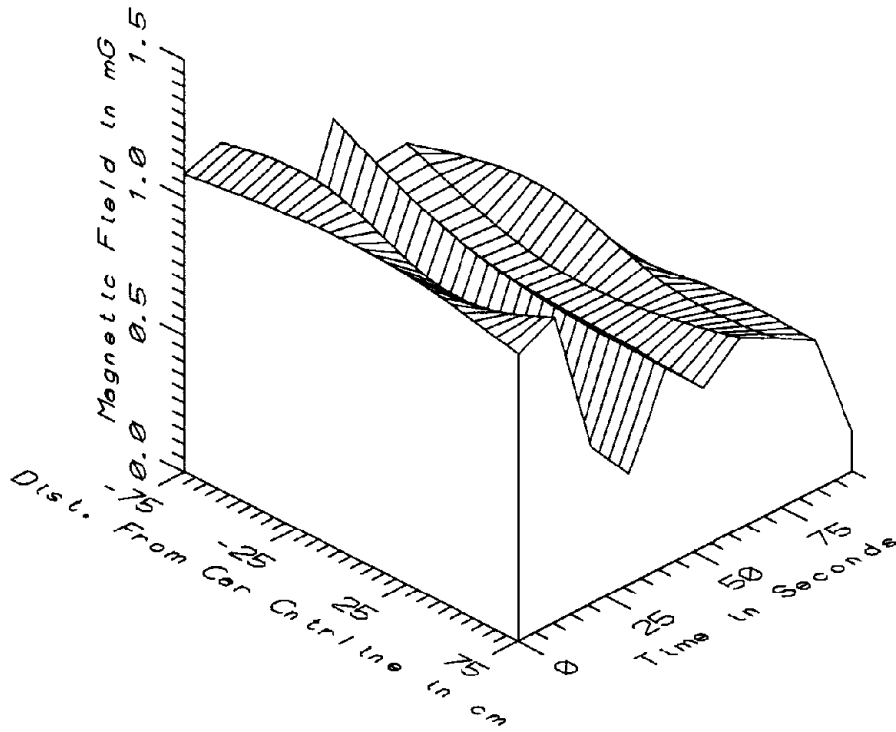

MET011 - TRANSVERSE PROFILE AT REAR OF CAR 3012 - HIGH FREQ, 305-2560Hz

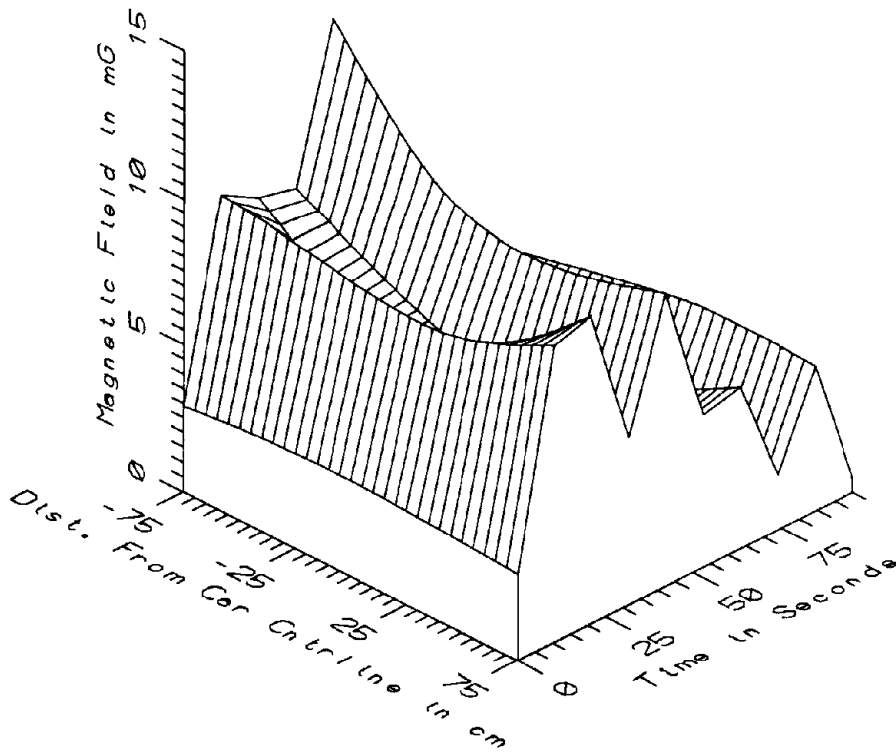

MET011 - TRANSVERSE PROFILE AT REAR OF CAR 3012 - ALL FREQ, 5-2560Hz

MET011 - TRANSVERSE PROFILE AT REAR OF CAR 3012		TOTAL OF 10 SAMPLES				
FREQUENCY BAND	DIST ALONG STAFF (cm)	MINIMUM MAGNETIC FIELD (mG)	MAXIMUM MAGNETIC FIELD (mG)	AVERAGE MAGNETIC FIELD (mG)	STANDARD DEVIATION (mG)	COEFFICIENT OF VARIATION (%)
STATIC	-75	286.12	1536.70	588.10	355.63	60.47
	-25	510.90	1571.96	766.55	309.72	40.40
	25	663.72	1594.80	902.46	276.93	30.69
	75	646.15	1609.41	938.63	277.86	29.60
5-45Hz	-75	0.28	13.38	5.71	4.22	73.93
LOW FREQ	-25	0.29	9.50	4.54	3.08	67.92
	25	0.30	8.83	4.48	2.95	65.90
	75	0.43	10.38	5.44	3.60	66.14
50-60Hz	-75	0.18	1.04	0.50	0.29	56.79
PWR FREQ	-25	0.11	1.02	0.41	0.26	64.15
	25	0.20	0.94	0.39	0.22	56.31
	75	0.10	1.23	0.41	0.34	82.02
65-300Hz	-75	0.06	2.10	1.11	0.59	52.70
PWR HARM	-25	0.15	2.34	1.04	0.59	57.04
	25	0.27	2.21	1.00	0.54	54.32
	75	0.19	2.08	0.99	0.56	57.00
305-2560Hz	-75	0.23	1.13	0.75	0.28	36.94
HIGH FREQ	-25	0.19	1.15	0.69	0.29	42.04
	25	0.15	1.13	0.64	0.28	44.28
	75	0.14	1.11	0.64	0.28	43.71
5-2560Hz	-75	0.41	13.54	6.00	4.09	68.21
ALL FREQ	-25	0.39	9.61	4.84	2.96	61.20
	25	0.48	8.92	4.76	2.83	59.46
	75	0.50	10.44	5.69	3.49	61.39

APPENDIX L

DATASET MET012  
TRANSVERSE PROFILE IN CENTER OF CAR #3090

Measurement Setup Code:      Staff:    3      Reference: -  
   Drawing: A-1

Vehicle Status:                    Traveling on the Red Line

Measurement Date:                May 19, 1992

Measurement Time:                Start:    10:33:46  
   End:      10:34:54

Number of Samples:                9

Programmed Sample Interval:    5 sec

Actual Sample Interval:         8.5 sec

Frequency Spectrum Parameters

<u>Probe Type:</u>	<u>Wideband</u>	<u>Static</u>
Maximum Frequency (Hz)	2560	100
Minimum Frequency (Hz)	5	0
Spectral Bandwidth (Hz)	5	1

Missing Data: No reference probe

Saturated Data - Static:	<u>Sensor</u>	<u>Sample</u>	<u>Time (sec)</u>
	25cm	8	60

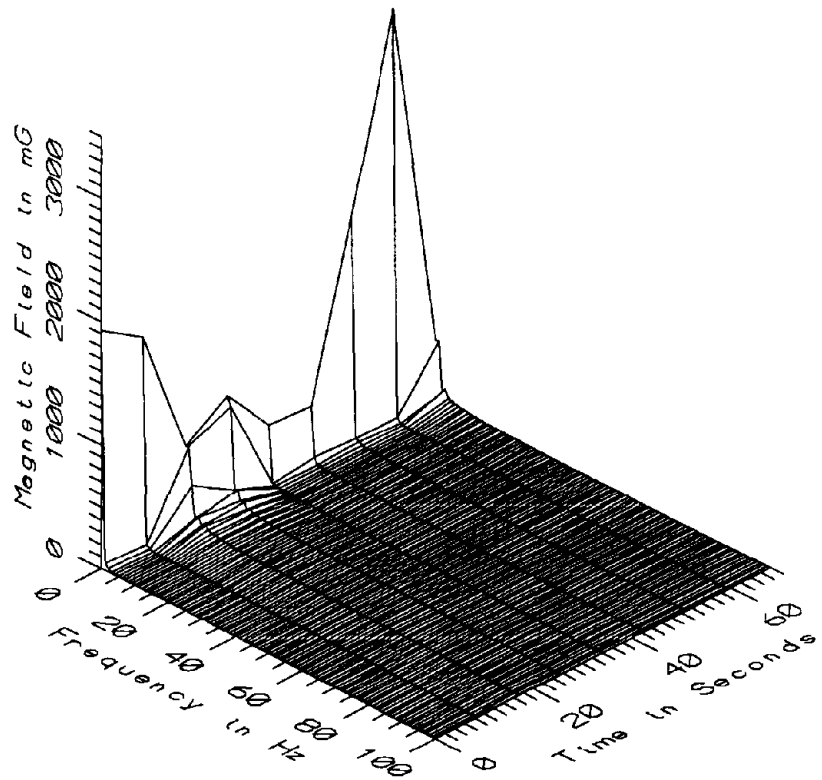

MET012 - -75cm FROM CAR CENTERLINE, CENTER OF CAR 3090

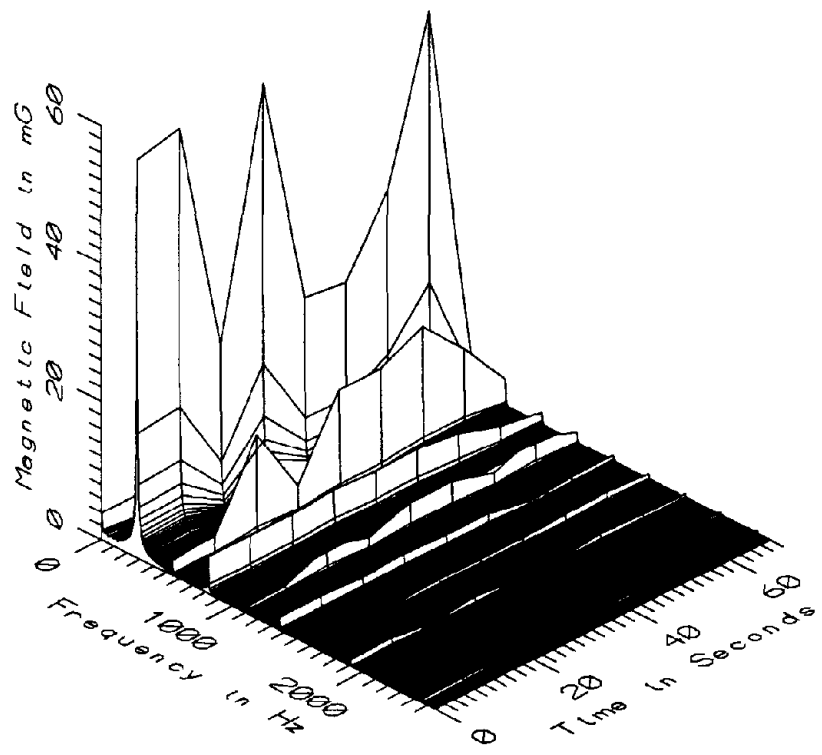

MET012 - -75cm FROM CAR CENTERLINE, CENTER OF CAR 3090

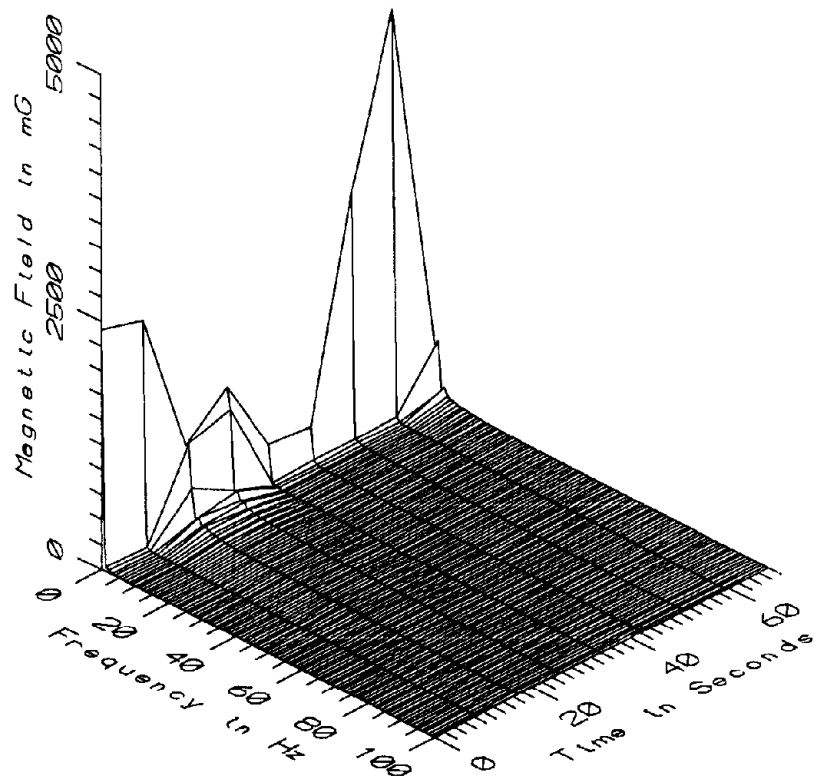

MET012 - -25cm FROM CAR CENTERLINE, CENTER OF CAR 3090

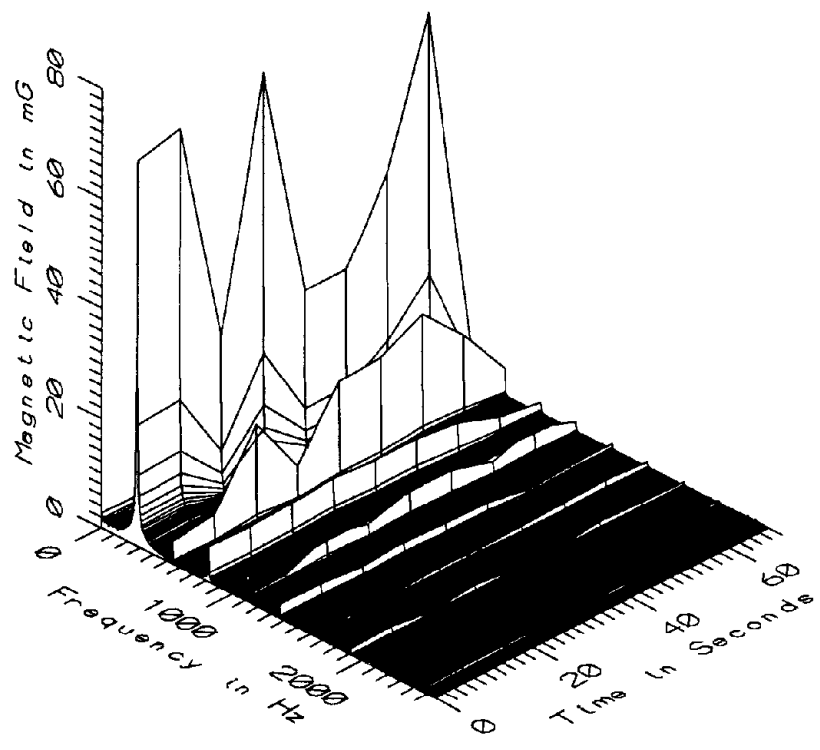

MET012 - -25cm FROM CAR CENTERLINE, CENTER OF CAR 3090

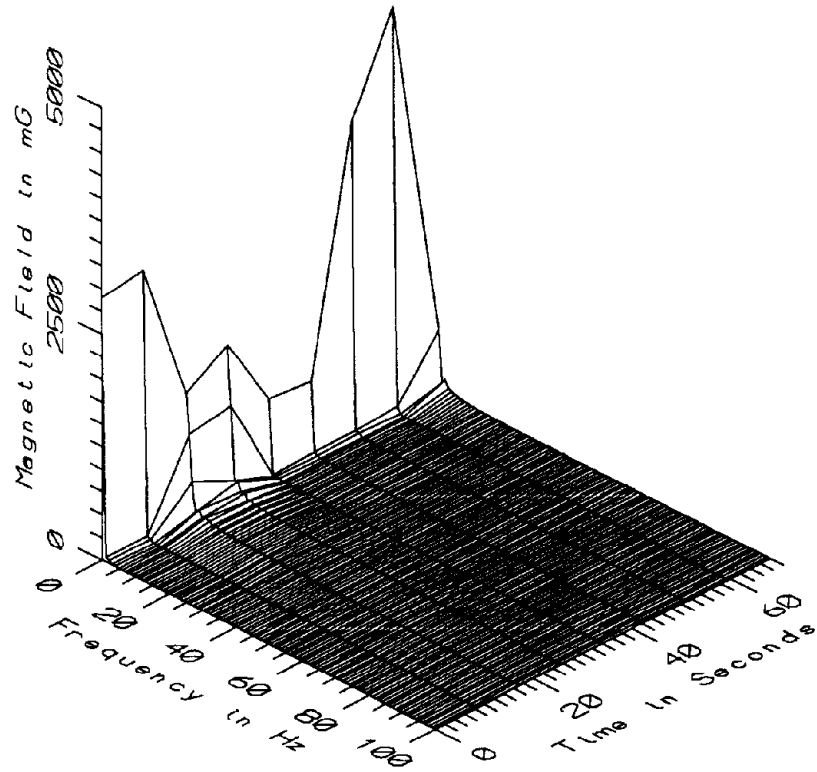

MET012 - 25cm FROM CAR CENTERLINE, CENTER OF CAR 3090

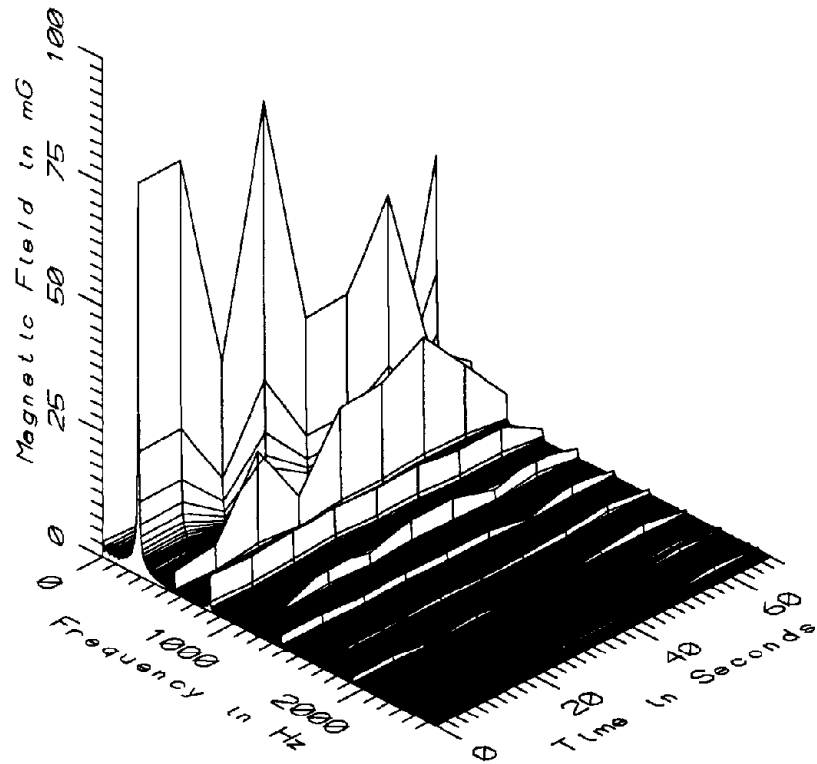

MET012 - 25cm FROM CAR CENTERLINE, CENTER OF CAR 3090

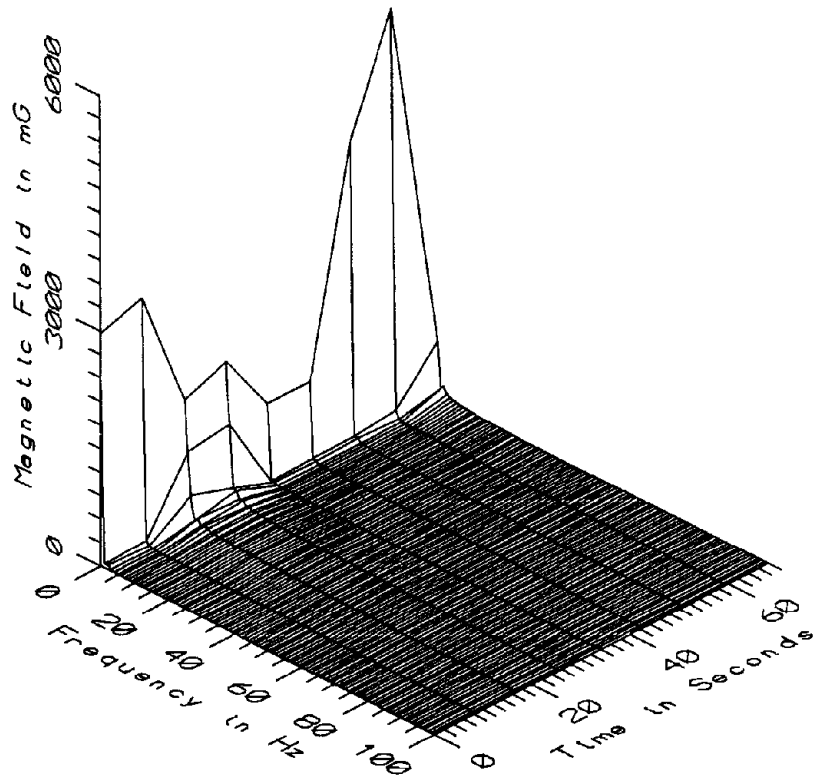

MET012 - 75cm FROM CAR CENTERLINE, CENTER OF CAR 3090

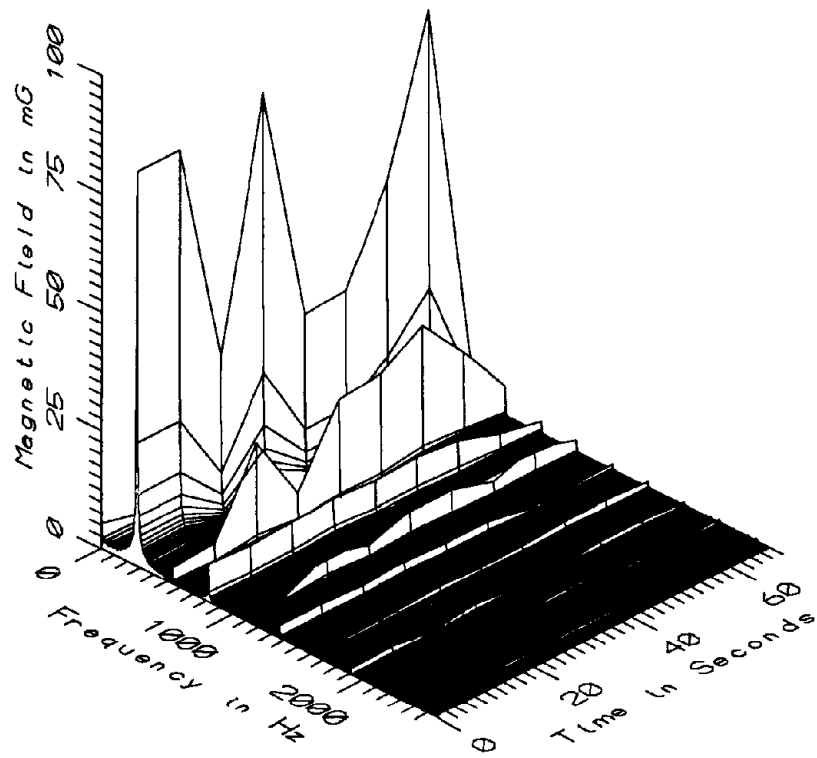

MET012 - 75cm FROM CAR CENTERLINE, CENTER OF CAR 3090

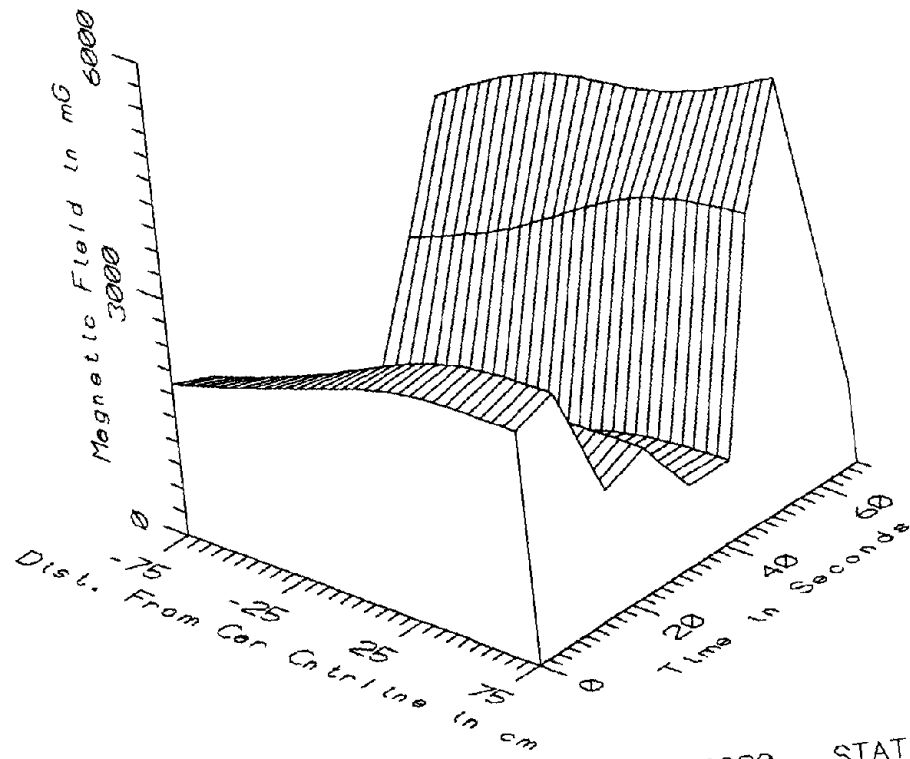

MET012 - TRANSVERSE PROFILE, CENTER OF CAR 3090 - STATIC

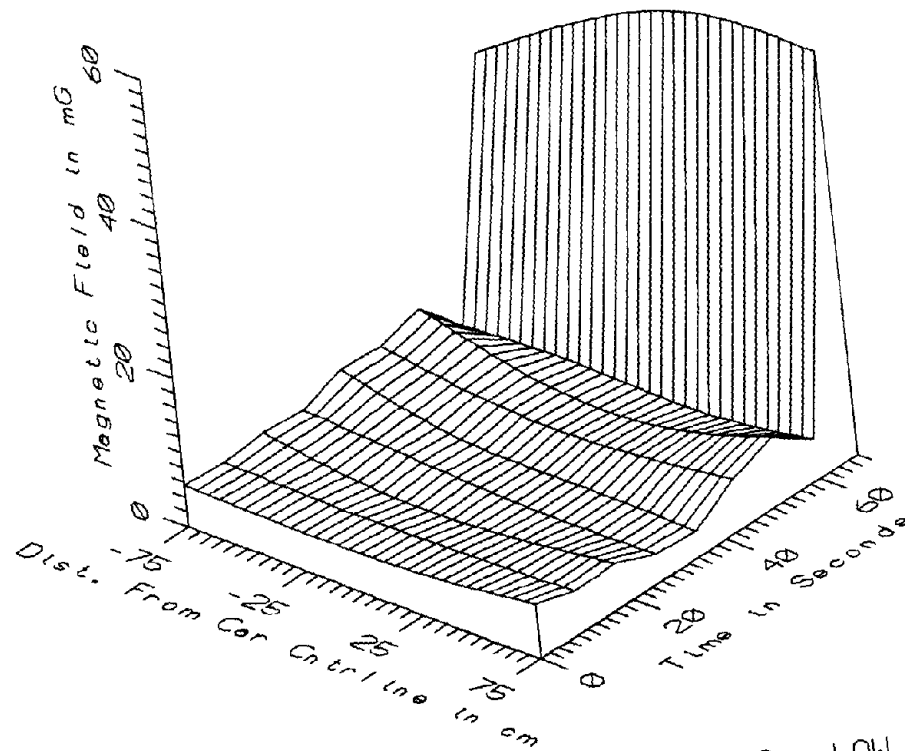

MET012 - TRANSVERSE PROFILE, CENTER OF CAR 3090 - LOW FREQ. 5-45Hz



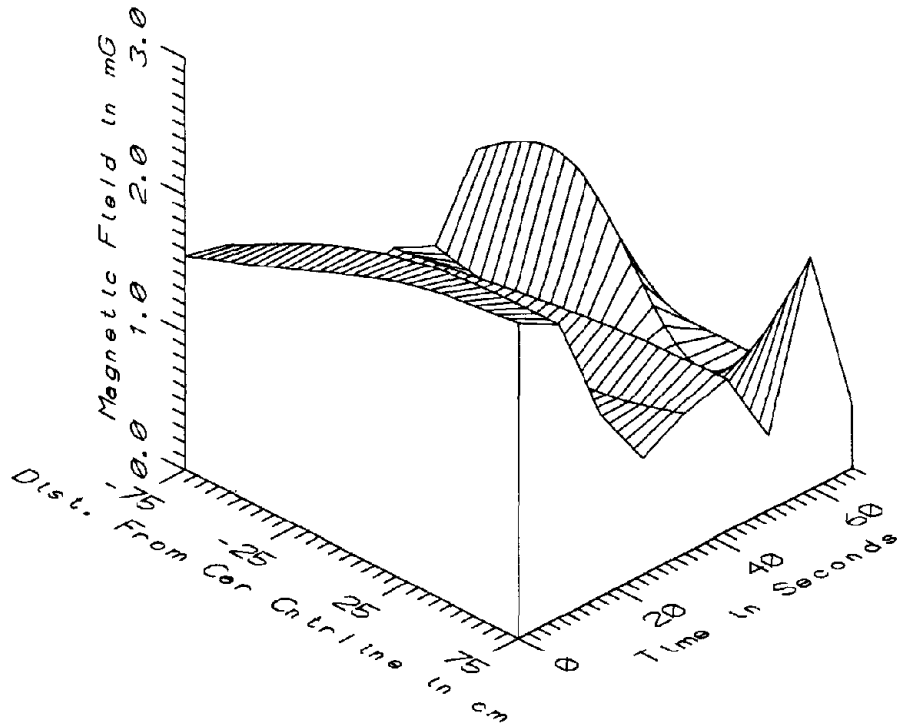

MET012 - TRANSVERSE PROFILE, CENTER OF CAR 3090 - POWER FREQ, 50-60Hz

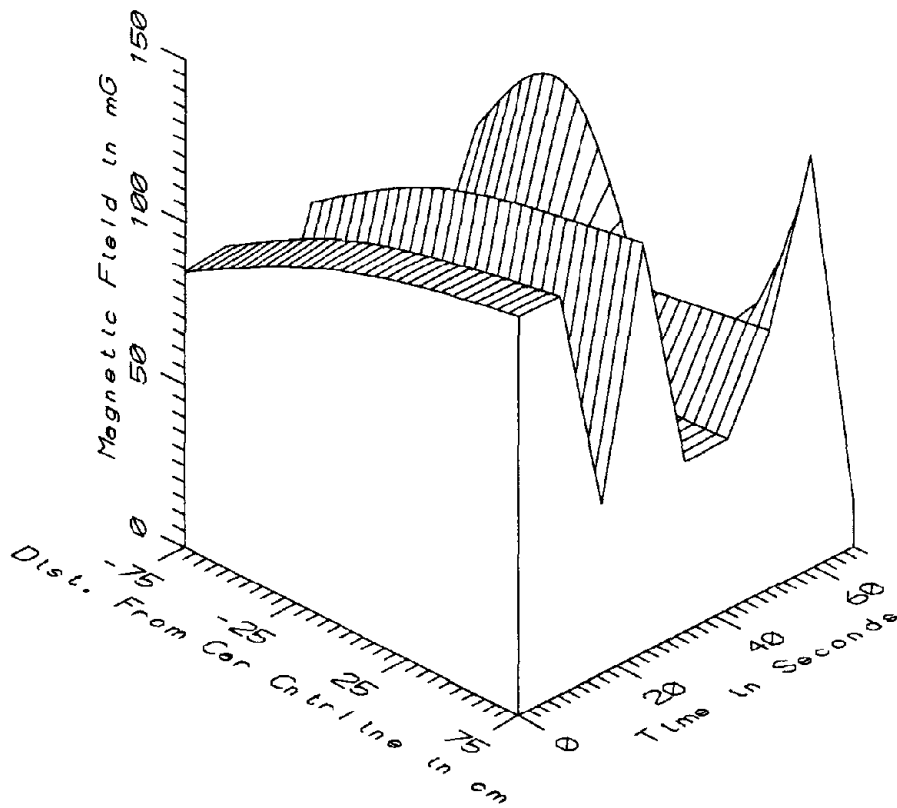

MET012 - TRANSVERSE PROFILE, CENTER OF CAR 3090 - POWER HARM, 65-300Hz

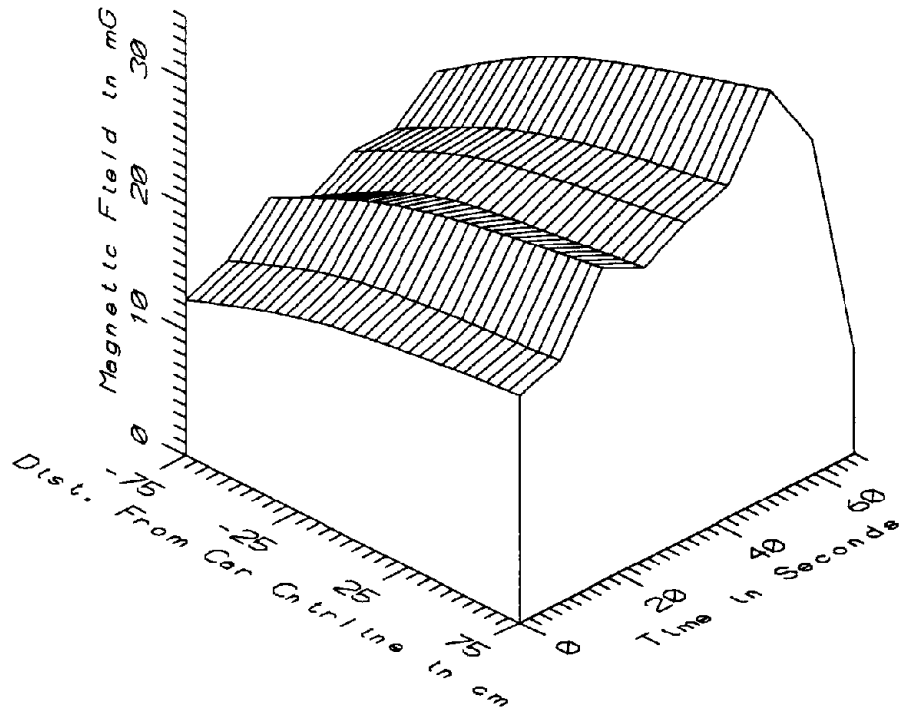

MET012 - TRANSVERSE PROFILE, CENTER OF CAR 3090 - HIGH FREQ, 305-2560Hz

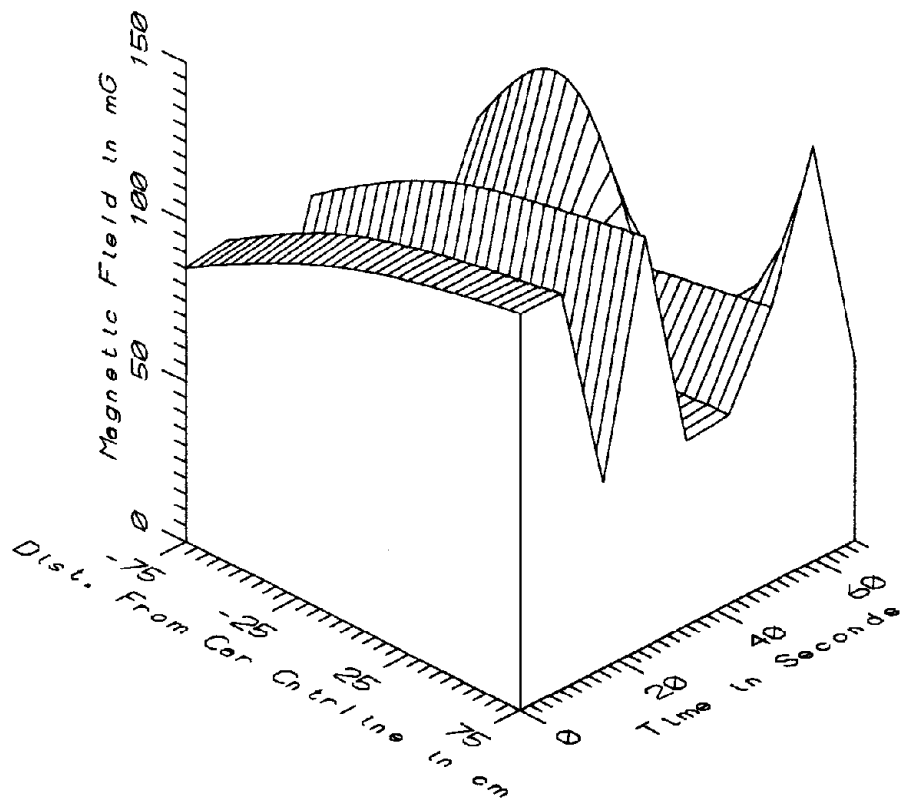

MET012 - TRANSVERSE PROFILE, CENTER OF CAR 3090 - ALL FREQ, 5-2560Hz

MET012 - TRANSVERSE PROFILE IN CENTER OF CAR 3090		TOTAL OF 9 SAMPLES				
FREQUENCY BAND	DIST ALONG STAFF (cm)	MINIMUM MAGNETIC FIELD (mG)	MAXIMUM MAGNETIC FIELD (mG)	AVERAGE MAGNETIC FIELD (mG)	STANDARD DEVIATION (mG)	COEFFICIENT OF VARIATION (%)
STATIC	-75	466.14	3340.44	1312.90	977.36	74.44
	-25	363.45	4169.84	1637.60	1299.81	79.37
	25	819.92	4487.64	2161.93	1332.73	61.65
	75	994.70	5209.65	2393.14	1483.17	61.98
5-45HZ LOW FREQ	-75	3.16	36.27	9.46	10.18	107.66
	-25	3.65	46.48	9.15	14.01	153.20
	25	3.49	53.25	9.86	16.29	165.11
	75	3.48	53.85	11.32	16.04	141.71
50-60HZ PWR FREQ	-75	0.56	1.55	1.03	0.34	33.37
	-25	0.50	1.87	1.14	0.50	44.12
	25	0.47	2.16	1.10	0.64	58.42
	75	0.46	2.28	1.26	0.65	51.30
65-300HZ PWR HARM	-75	9.05	86.50	56.69	29.15	51.43
	-25	11.78	108.58	70.44	35.61	50.55
	25	13.30	119.36	67.87	40.49	59.66
	75	14.16	126.89	83.09	42.45	51.09
305-2560HZ HIGH FREQ	-75	5.31	20.45	15.25	4.40	28.87
	-25	6.70	26.12	19.16	5.59	29.17
	25	7.54	29.60	20.80	6.18	29.69
	75	8.32	32.42	22.78	6.85	30.06
5-2560HZ ALL FREQ	-75	37.76	88.07	62.56	23.44	37.47
	-25	48.42	110.53	77.57	28.57	36.84
	25	30.72	121.45	76.52	33.69	44.03
	75	56.30	129.81	91.53	34.33	37.51



APPENDIX M

DATASET MET013  
AXIAL PROFILE IN CENTER OF CAR #3090

Measurement Setup Code:           Staff:    2     Reference:  -  
  Drawing:  A-1

Vehicle Status:                    Traveling on the Red Line

Measurement Date:                 May 19, 1992

Measurement Time:                 Start:     10:35:25  
  End:       10:37:53

Number of Samples:                 18

Programmed Sample Interval:       5 sec

Actual Sample Interval:           8.7 sec

Frequency Spectrum Parameters

<u>Probe Type:</u>	<u>Wideband</u>	<u>Static</u>
Maximum Frequency (Hz)	2560	100
Minimum Frequency (Hz)	5	0
Spectral Bandwidth (Hz)	5	1

Missing Data: No reference probe

Saturated Data - Wideband:	<u>Sensor</u>	<u>Sample</u>	<u>Time (sec)</u>
	75cm	2	9
Saturated Data - Static:	<u>Sensor</u>	<u>Sample</u>	<u>Time (sec)</u>
	-25cm	1	0
	25cm	1	0
	75cm	1	0

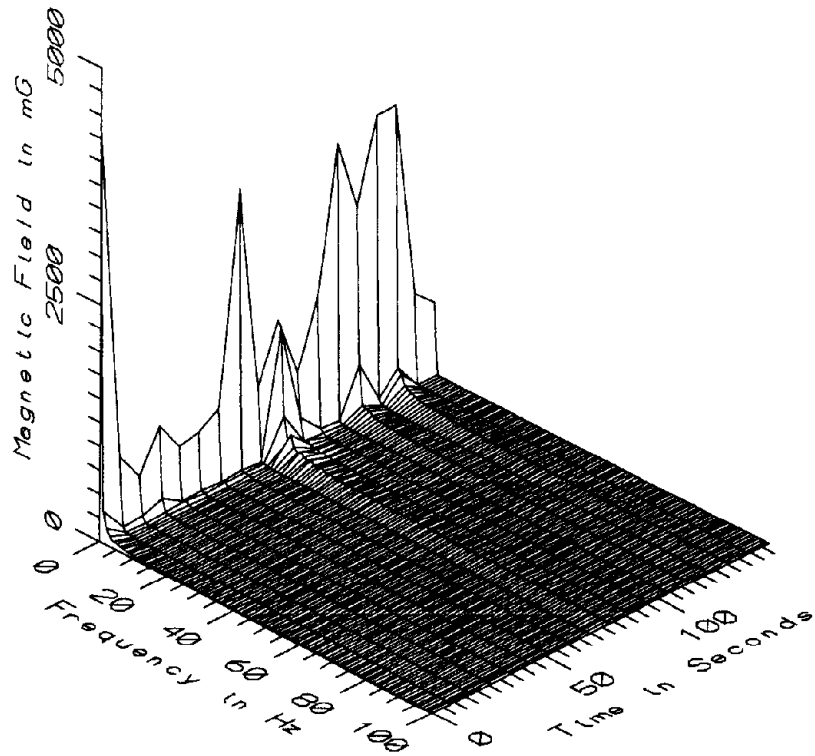

MET013 - -75cm FROM CENTERLINE OF MID DOORS ALONG AXIS OF CAR 3090

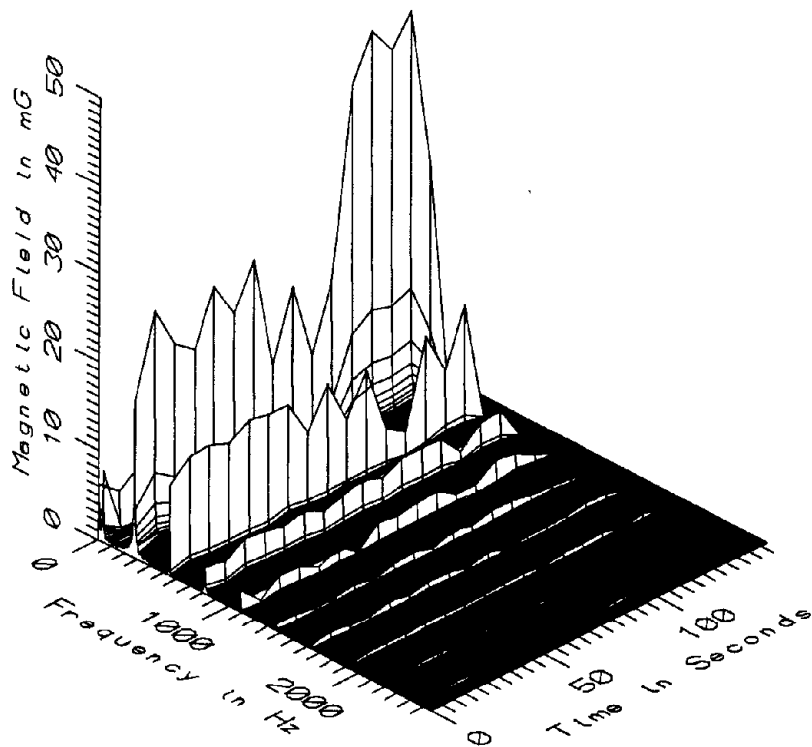

MET013 - -75cm FROM CENTERLINE OF MID DOORS ALONG AXIS OF CAR 3090

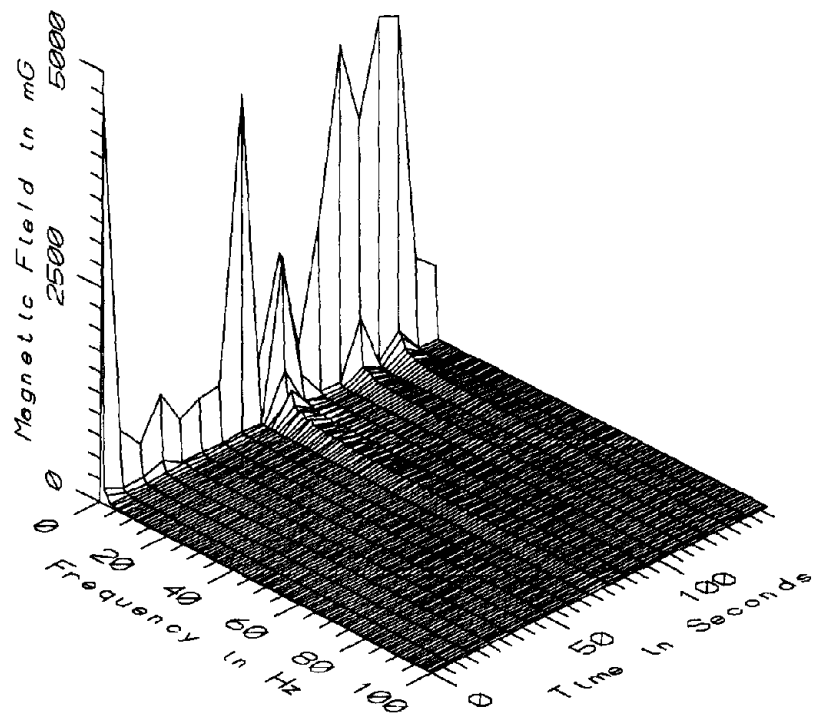

MET013 - -25cm FROM CENTERLINE OF MID DOORS ALONG AXIS OF CAR 3090

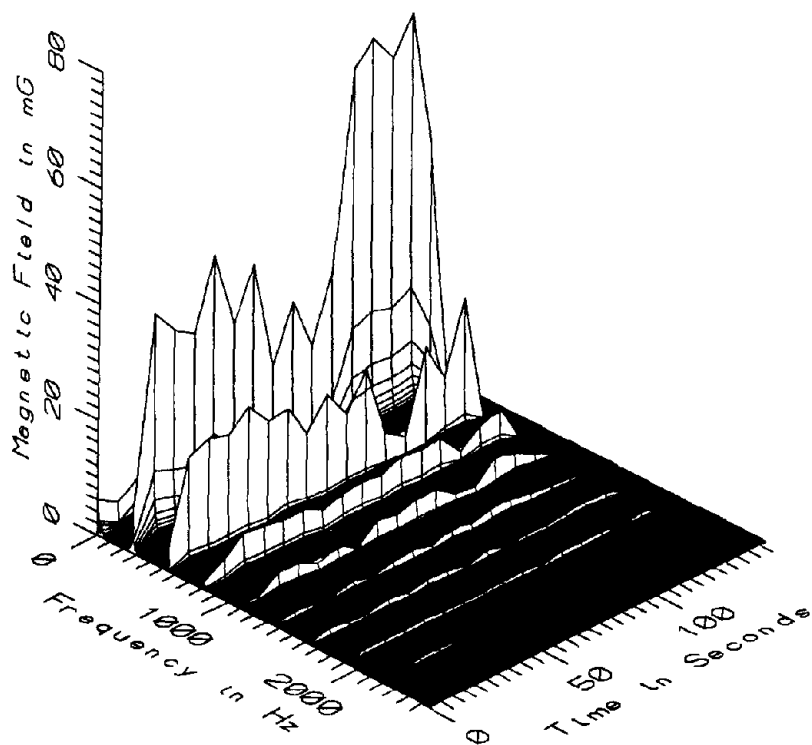

MET013 - -25cm FROM CENTERLINE OF MID DOORS ALONG AXIS OF CAR 3090

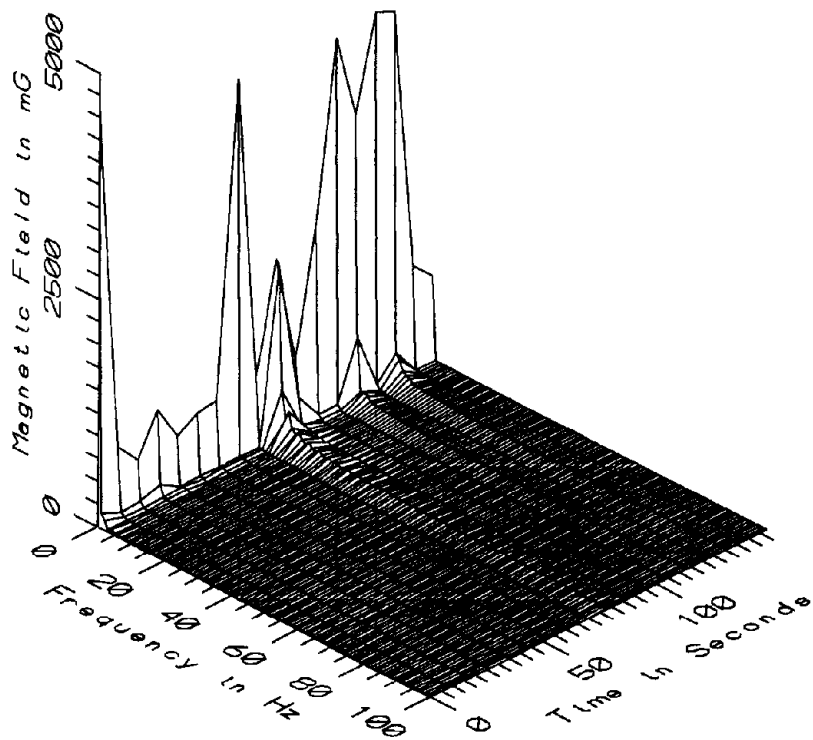

MET013 - 25cm FROM CENTERLINE OF MID DOORS ALONG AXIS OF CAR 3090

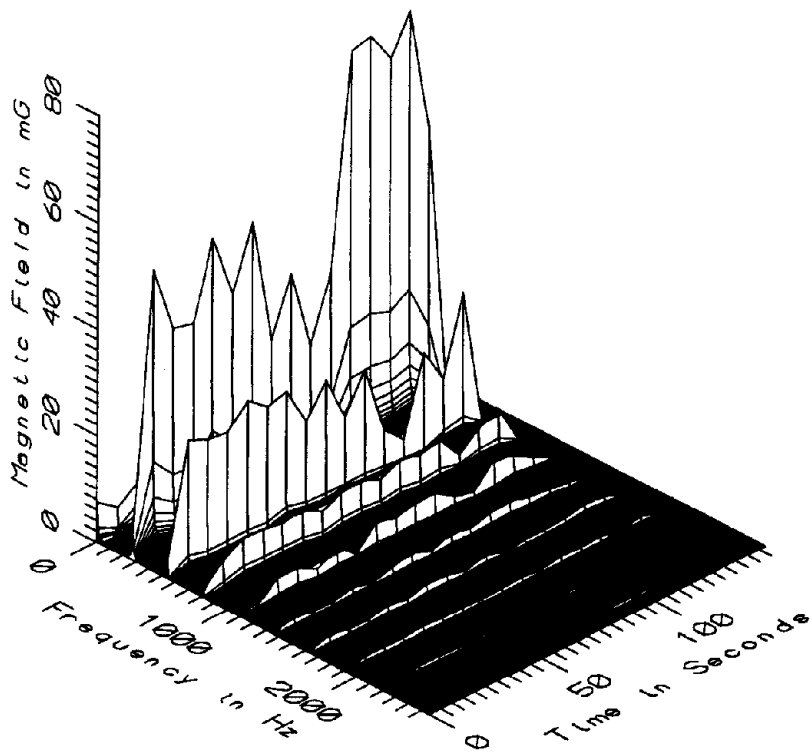

MET013 - 25cm FROM CENTERLINE OF MID DOORS ALONG AXIS OF CAR 3090



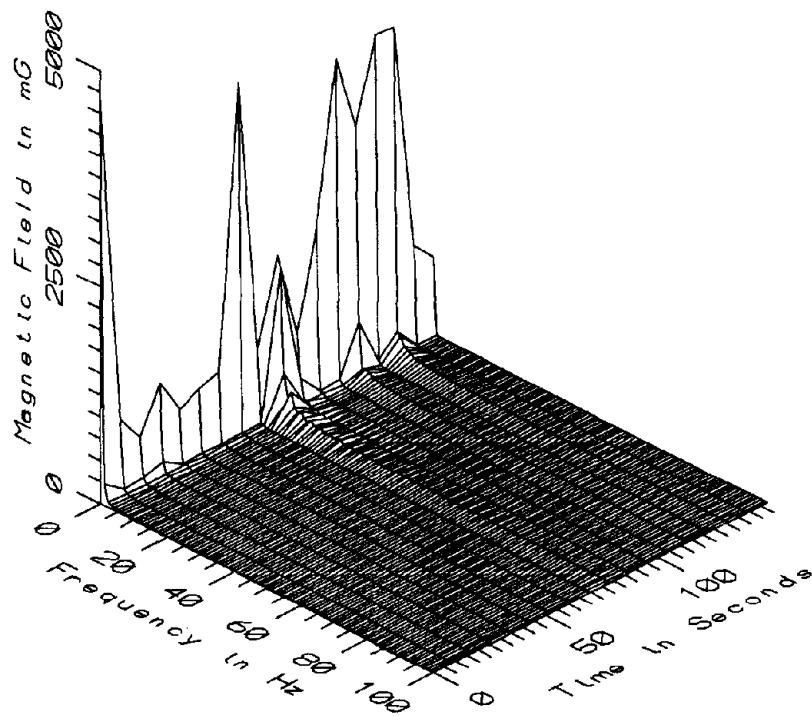

MET013 - 75cm FROM CENTERLINE OF MID DOORS ALONG AXIS OF CAR 3090

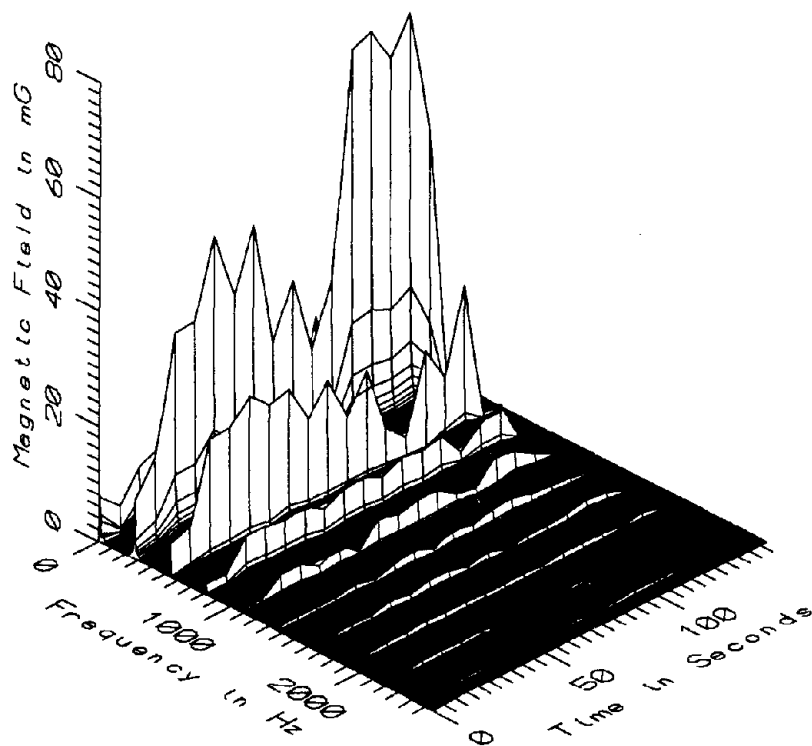

MET013 - 75cm FROM CENTERLINE OF MID DOORS ALONG AXIS OF CAR 3090

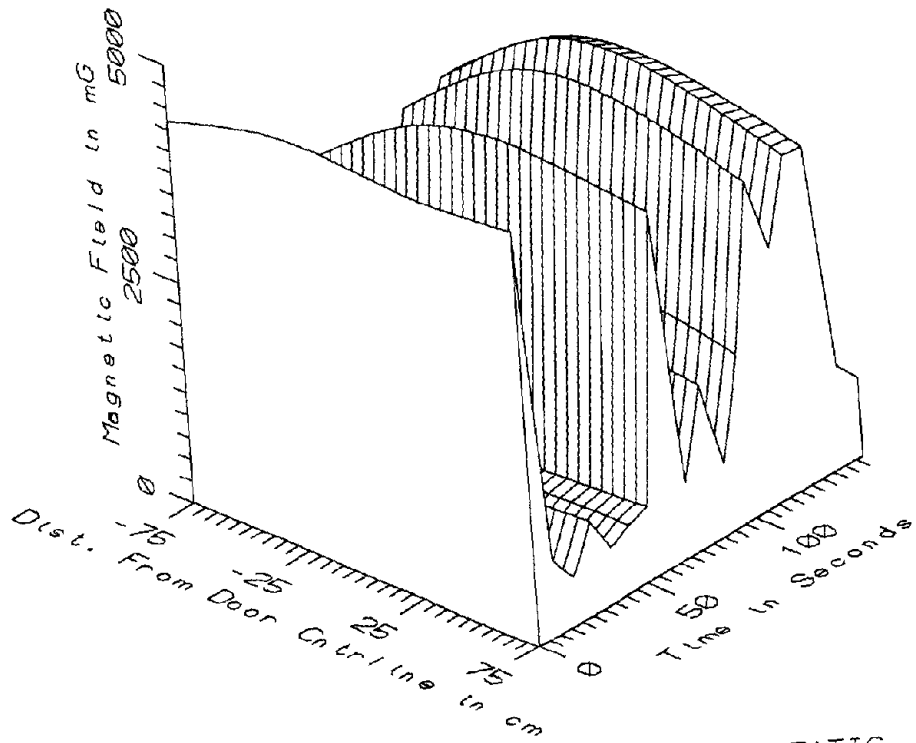

MET013 - AXIAL PROFILE, CENTER OF CAR 3090 - STATIC

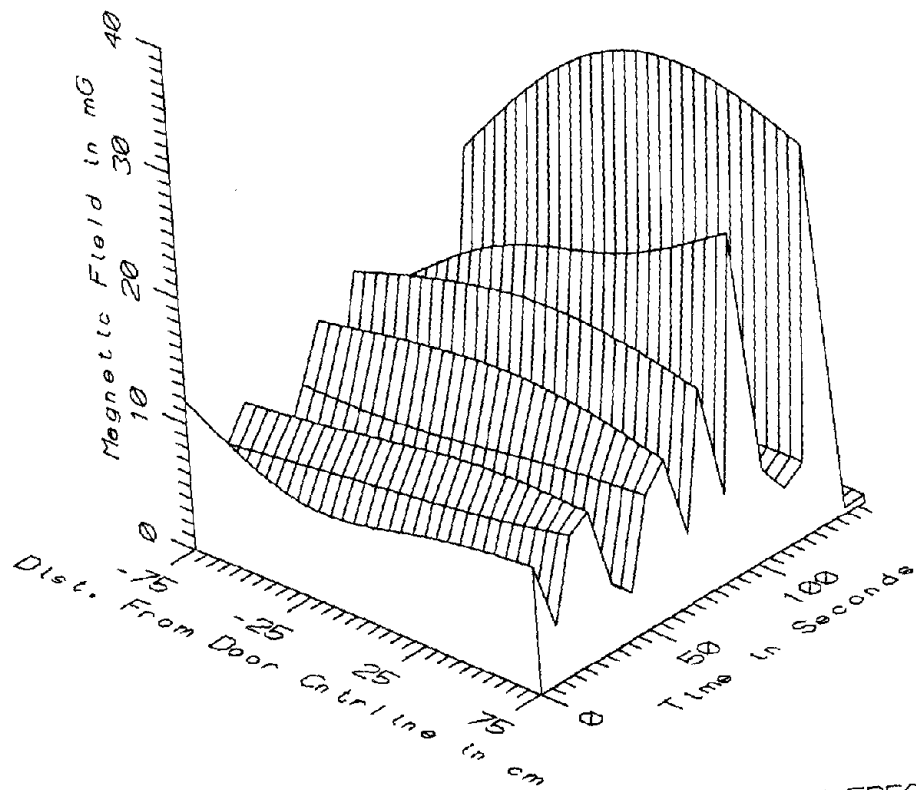

MET013 - AXIAL PROFILE, CENTER OF CAR 3090 - LOW FREQ. 5-45Hz

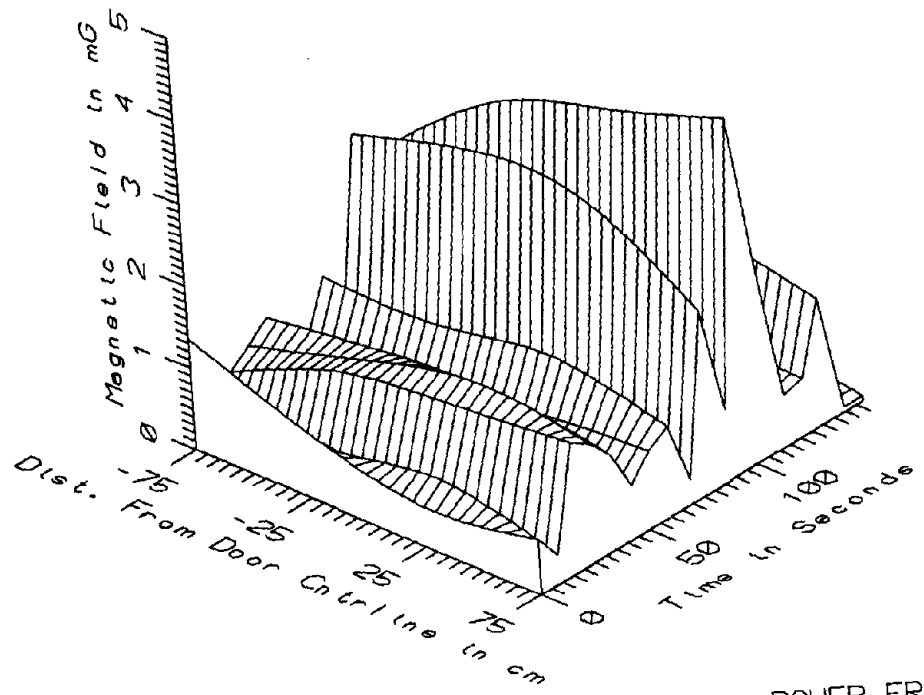

MET013 - AXIAL PROFILE, CENTER OF CAR 3090 - POWER FREQ, 50-60Hz

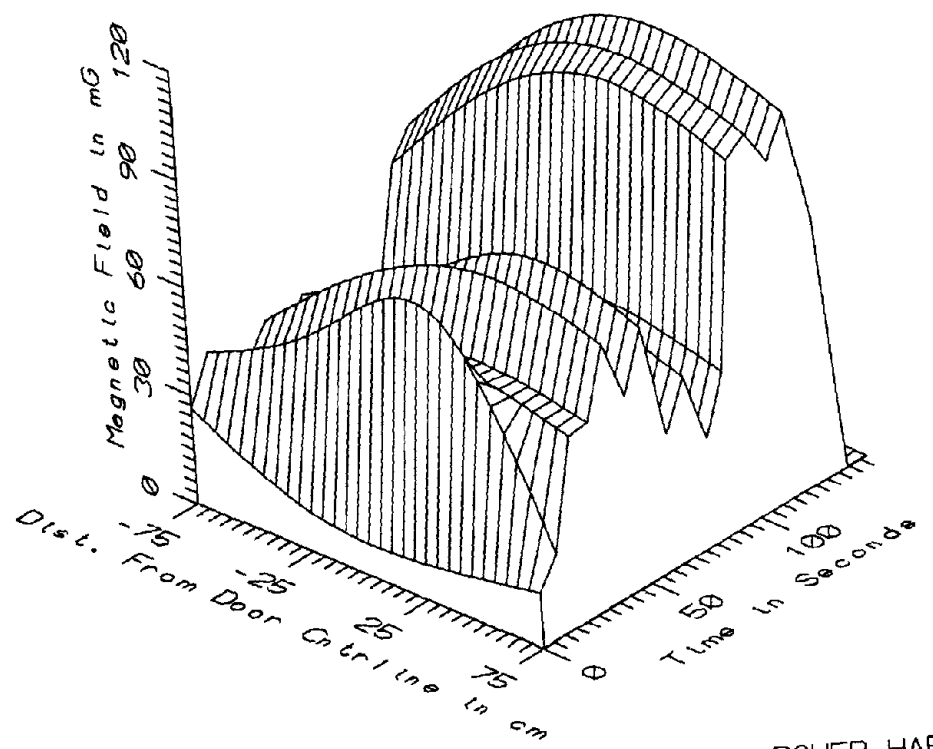

MET013 - AXIAL PROFILE, CENTER OF CAR 3090 - POWER HARM, 65-300Hz

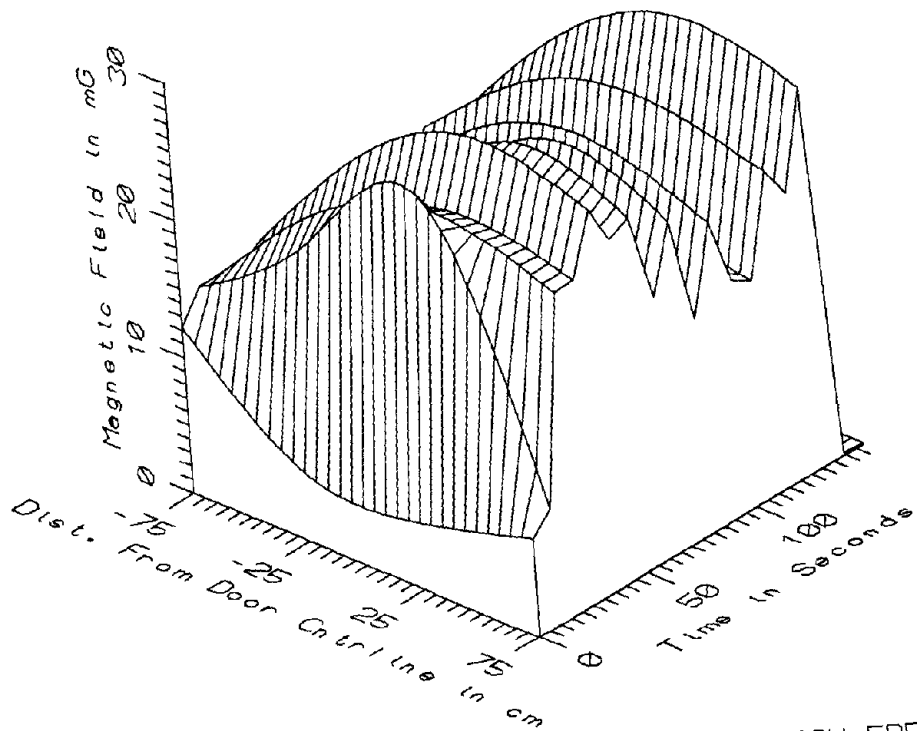

MET013 - AXIAL PROFILE, CENTER OF CAR 3090 - HIGH FREQ, 305-2560Hz

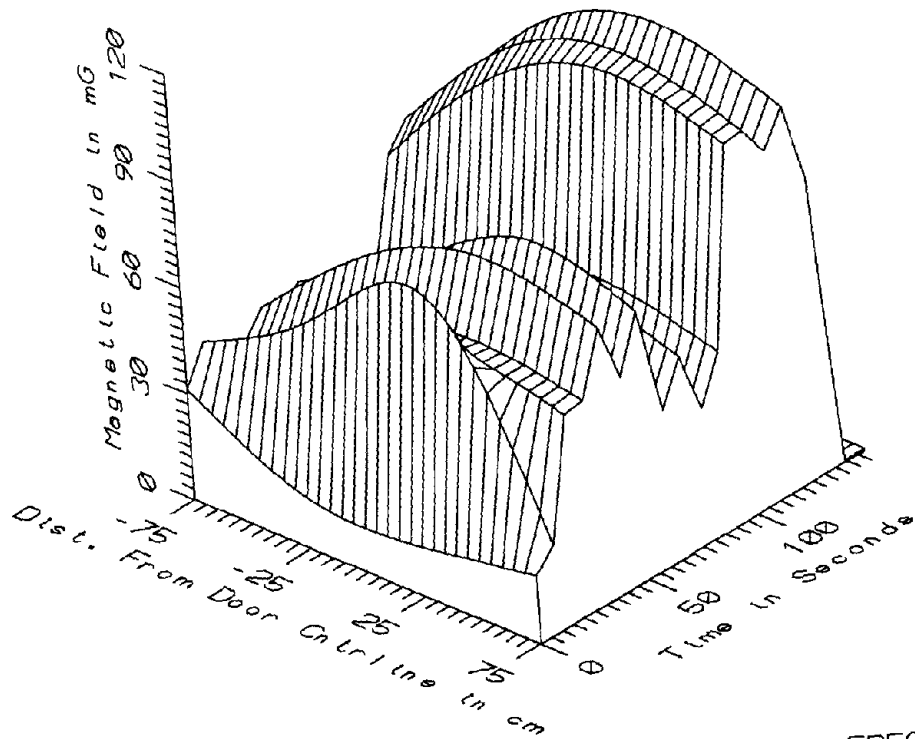

MET013 - AXIAL PROFILE, CENTER OF CAR 3090 - ALL FREQ, 5-2560Hz

MET013 - AXIAL PROFILE IN CENTER OF CAR 3090				TOTAL OF 18 SAMPLES			
FREQUENCY BAND	DIST ALONG STAFF (cm)	MINIMUM MAGNETIC FIELD (mG)	MAXIMUM MAGNETIC FIELD (mG)	AVERAGE MAGNETIC FIELD (mG)	STANDARD DEVIATION (mG)	COEFFICIENT OF VARIATION (%)	
STATIC	-75	477.17	4343.61	1601.53	1175.14	73.38	
	-25	445.37	4681.48	1921.42	1543.91	80.35	
	25	516.73	4628.13	2010.27	1556.31	77.42	
	75	536.63	4722.76	1949.68	1448.61	74.30	
5-45HZ	-75	0.42	18.50	7.57	4.62	61.06	
LOW FREQ	-25	0.37	29.22	8.60	7.06	82.11	
	25	0.45	32.93	9.44	8.03	85.09	
	75	0.53	30.26	9.69	8.01	82.72	
50-60HZ	-75	0.15	2.60	0.88	0.68	76.99	
PWR FREQ	-25	0.09	3.30	1.09	0.92	84.50	
	25	0.21	3.79	1.23	1.00	81.42	
	75	0.06	4.27	1.15	1.01	88.21	
65-300HZ	-75	0.10	67.84	35.20	19.81	56.28	
PWR HARM	-25	0.16	102.44	52.61	31.77	60.38	
	25	0.20	113.89	62.02	35.83	57.77	
	75	0.22	105.21	54.45	33.58	61.68	
305-2560HZ	-75	0.09	16.02	11.81	4.70	39.81	
HIGH FREQ	-25	0.12	25.00	17.11	7.78	45.46	
	25	0.13	29.72	20.52	9.52	46.39	
	75	0.14	27.93	18.23	8.76	48.08	
5-2560HZ	-75	0.47	68.93	38.53	19.62	50.92	
ALL FREQ	-25	0.44	104.51	56.83	31.95	56.21	
	25	0.59	116.25	66.97	36.14	53.96	
	75	0.63	106.92	59.11	34.08	57.65	



APPENDIX N

DATASET MET014  
NEAR LEFT CENTER DOOR OF CAR #3090

Measurement Setup Code:      Staff:    4    Reference: -  
   Drawing: A-1

Vehicle Status:                    Traveling on the Red Line

Measurement Date:                May 19, 1992

Measurement Time:                Start:    10:38:48  
   End:      10:39:55

Number of Samples:                6

Programmed Sample Interval:    5 sec

Actual Sample Interval:         13.4 sec

Frequency Spectrum Parameters

<u>Probe Type:</u>	<u>Wideband</u>	<u>Static</u>
Maximum Frequency (Hz)	2560	100
Minimum Frequency (Hz)	5	0
Spectral Bandwidth (Hz)	5	1

Missing Data: No reference probe

Saturated Data - Wideband:	<u>Sensor</u>	<u>Sample</u>	<u>Time (sec)</u>
	10cm	1	0
	10cm	2	13
	10cm	4	40
	60cm	4	40
	110cm	4	40

Saturated Data - Static:	<u>Sensor</u>	<u>Sample</u>	<u>Time (sec)</u>
	10cm	1	0
	10cm	2	13
	10cm	3	27
	10cm	4	40
	10cm	5	54
	60cm	2	13
	60cm	5	54

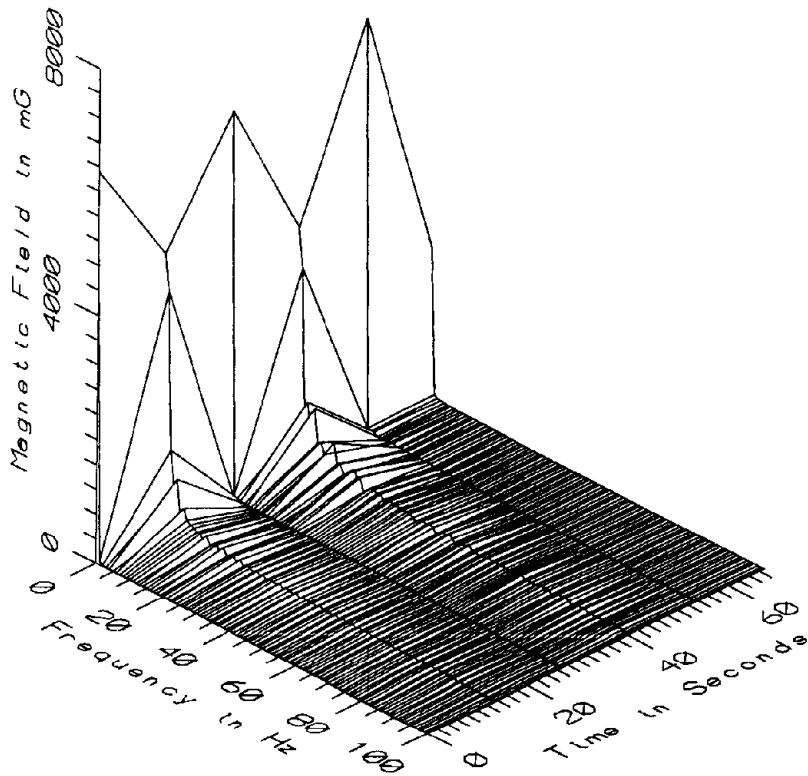

MET014 - 10cm ABOVE FLOOR, NEAR LEFT CENTER DOOR OF CAR 3090

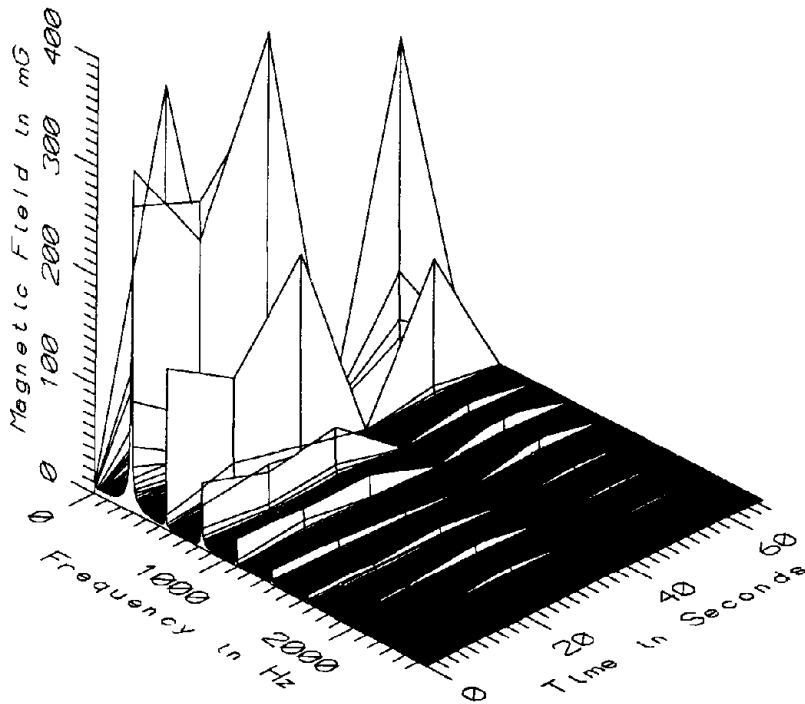

MET014 - 10cm ABOVE FLOOR, NEAR LEFT CENTER DOOR OF CAR 3090



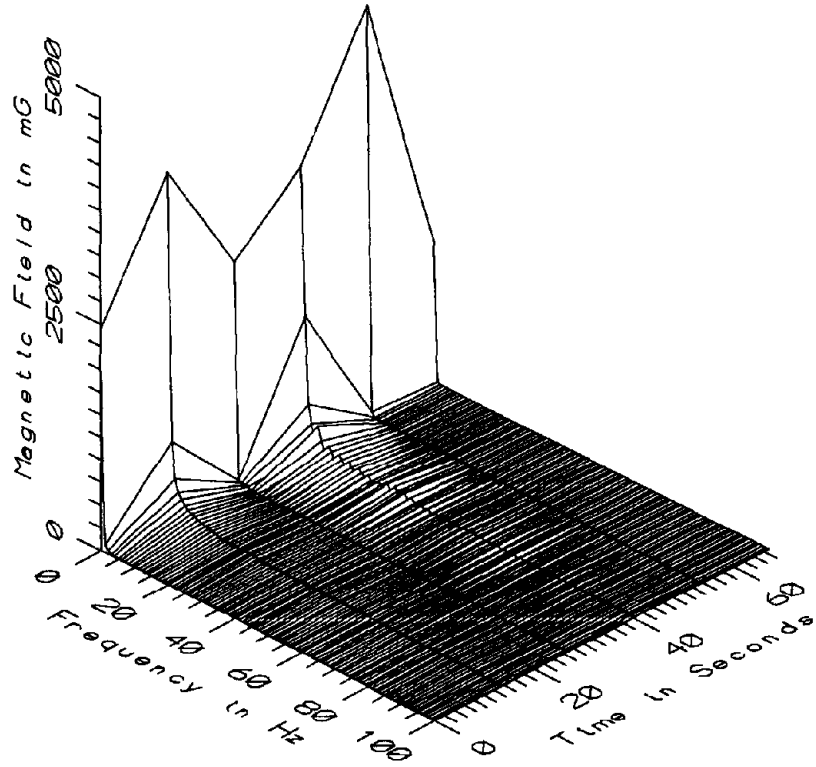

MET014 - 60cm ABOVE FLOOR, NEAR LEFT CENTER DOOR OF CAR 3090

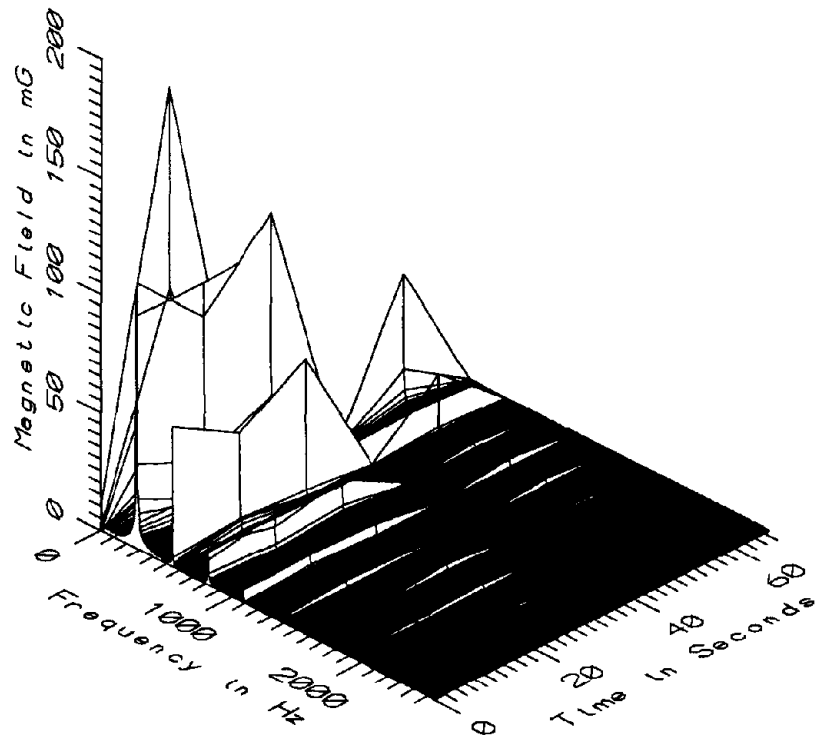

MET014 - 60cm ABOVE FLOOR, NEAR LEFT CENTER DOOR OF CAR 3090

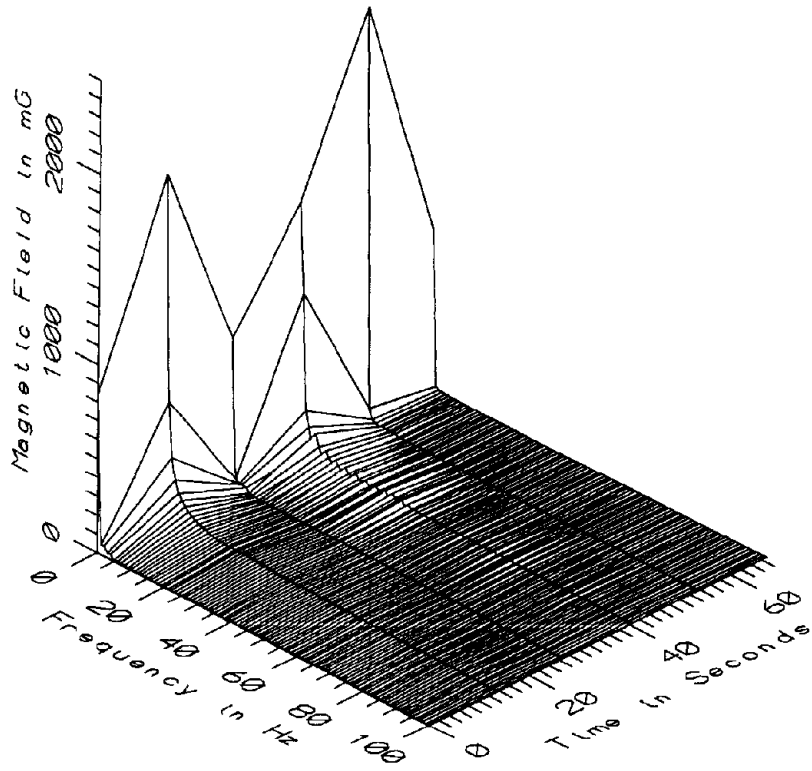

MET014 - 110cm ABOVE FLOOR, NEAR LEFT CENTER DOOR OF CAR 3090

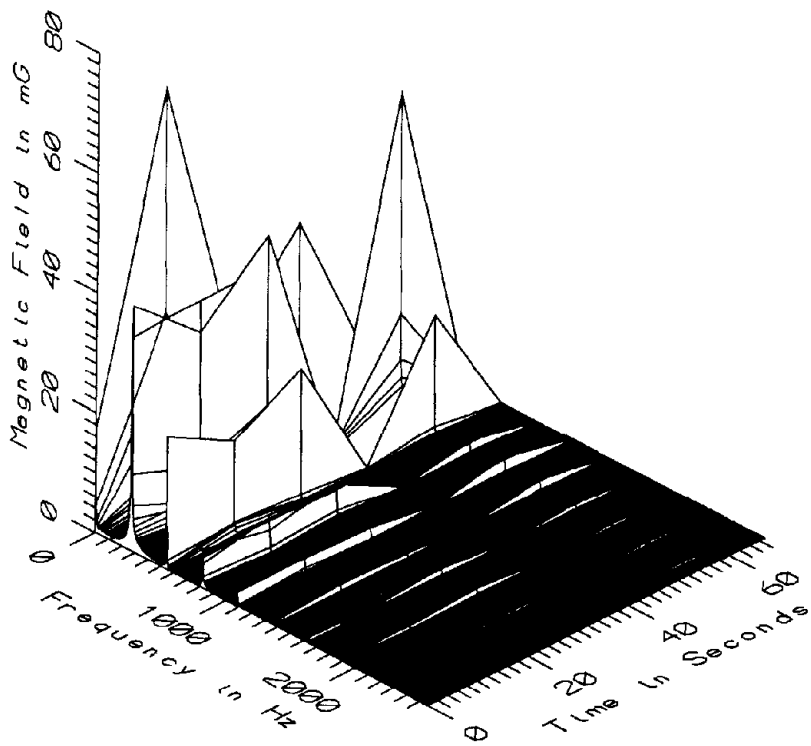

MET014 - 110cm ABOVE FLOOR, NEAR LEFT CENTER DOOR OF CAR 3090

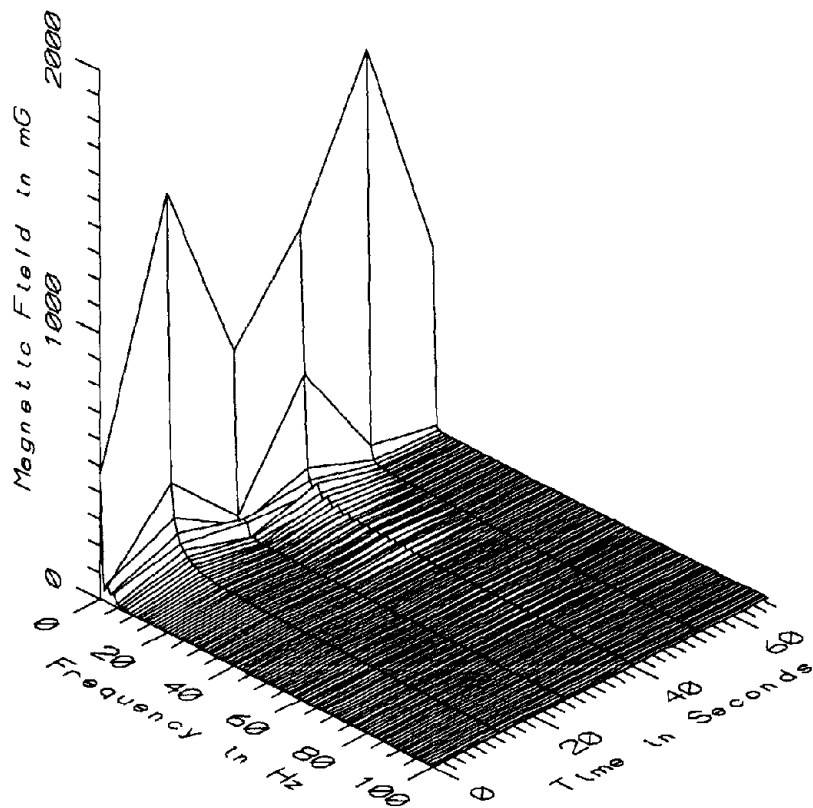

MET014 - 160<sub>cm</sub> ABOVE FLOOR, NEAR LEFT CENTER DOOR OF CAR 3090

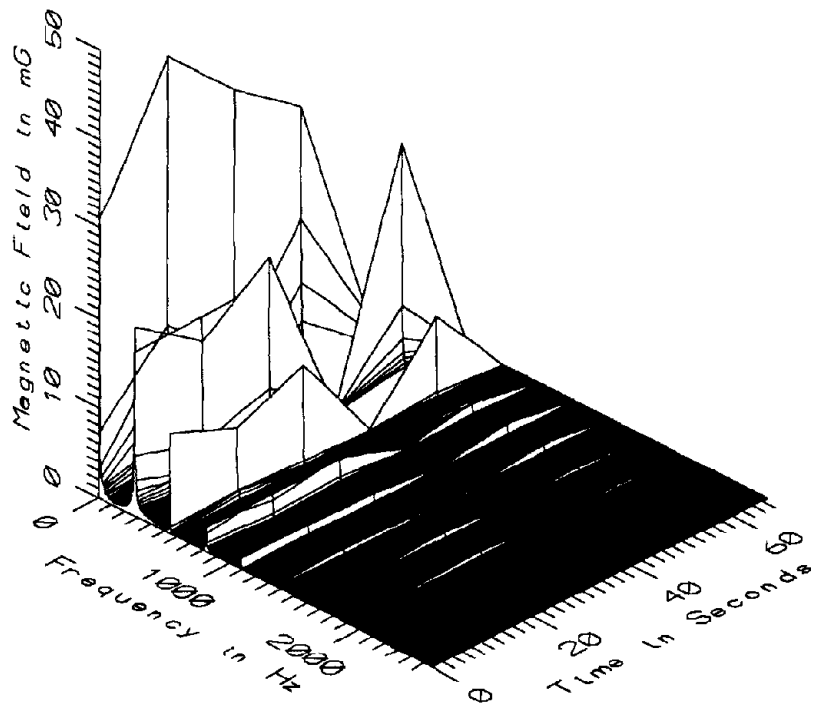

MET014 - 160<sub>cm</sub> ABOVE FLOOR, NEAR LEFT CENTER DOOR OF CAR 3090

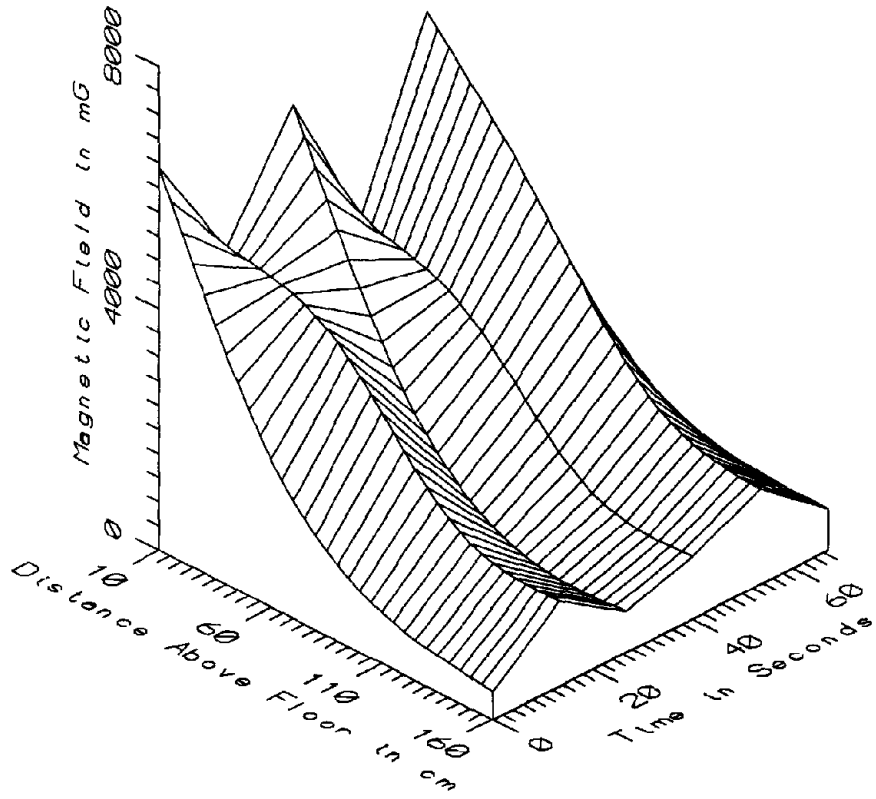

MET014 - NEAR LEFT CENTER DOOR OF CAR 3090 - STATIC

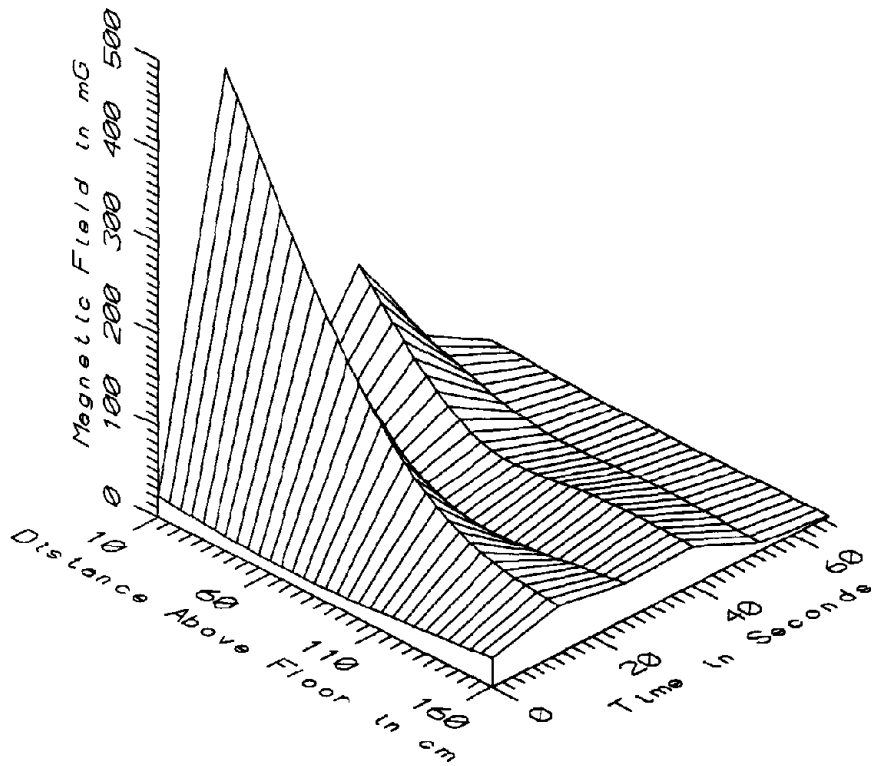

MET014 - NEAR LEFT CENTER DOOR OF CAR 3090 - LOW FREQ, 5-45Hz

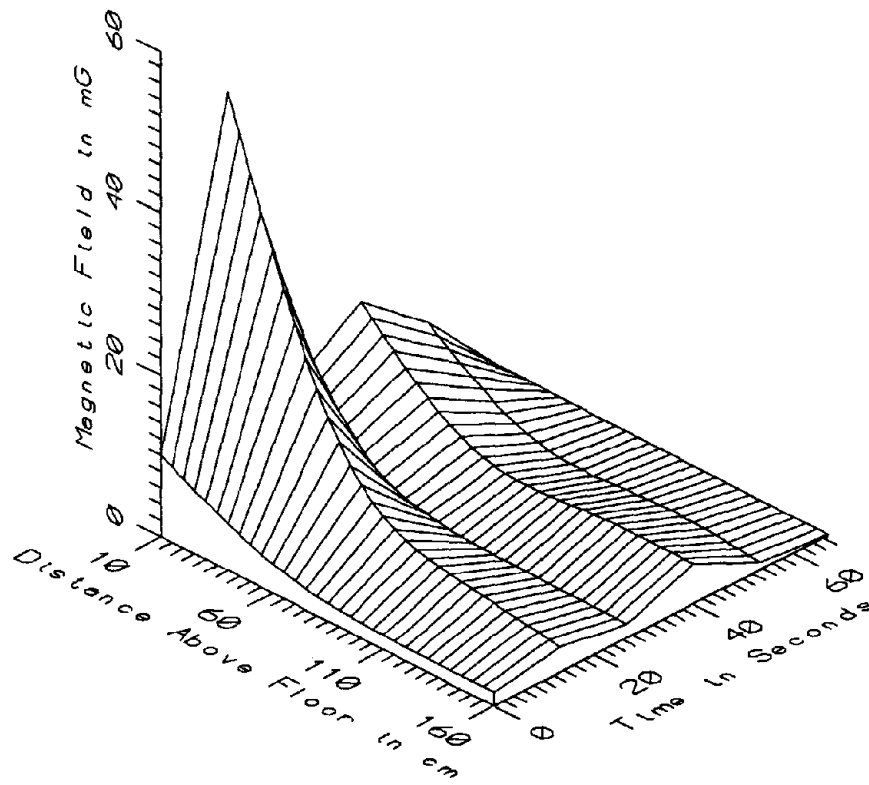

MET014 - NEAR LEFT CENTER DOOR OF CAR 3090 - POWER FREQ, 50-60Hz

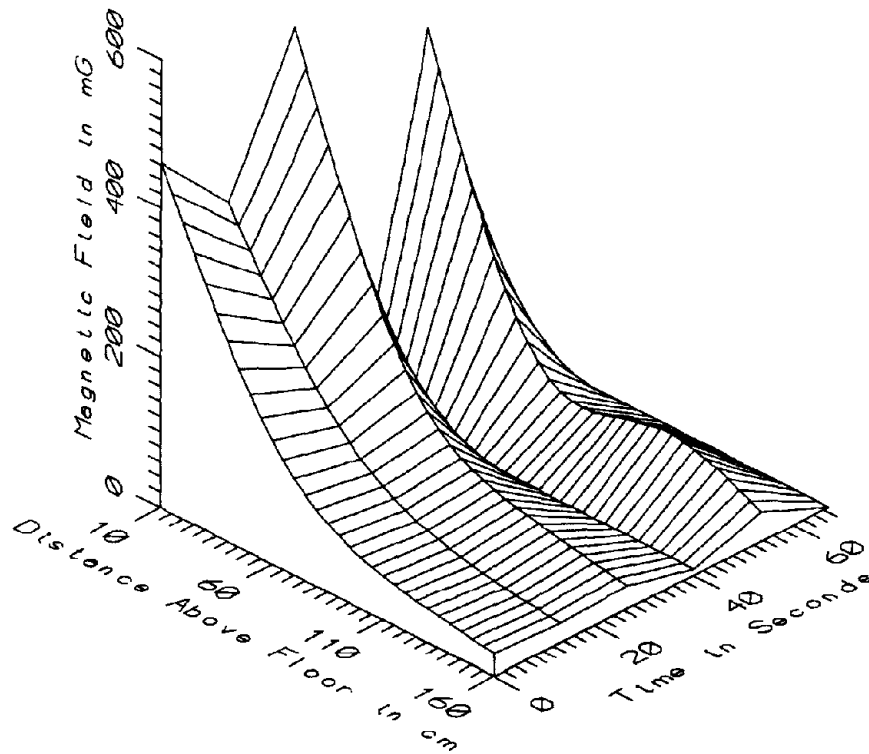

MET014 - NEAR LEFT CENTER DOOR OF CAR 3090 - POWER HARM, 65-300Hz

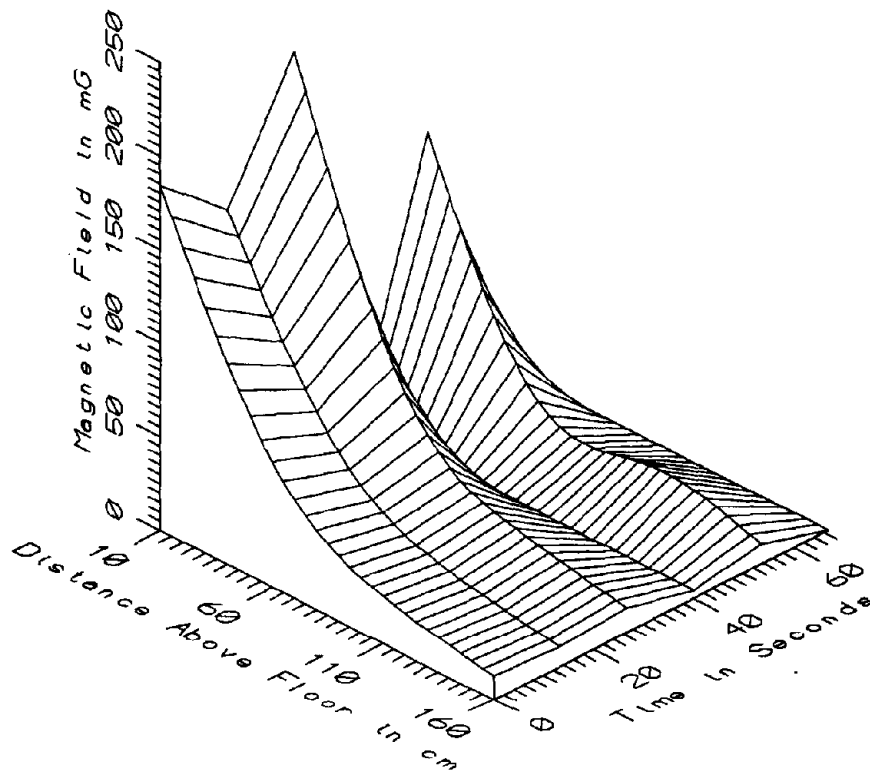

MET014 - NEAR LEFT CENTER DOOR OF CAR 3090 - HIGH FREQ, 305-2560Hz

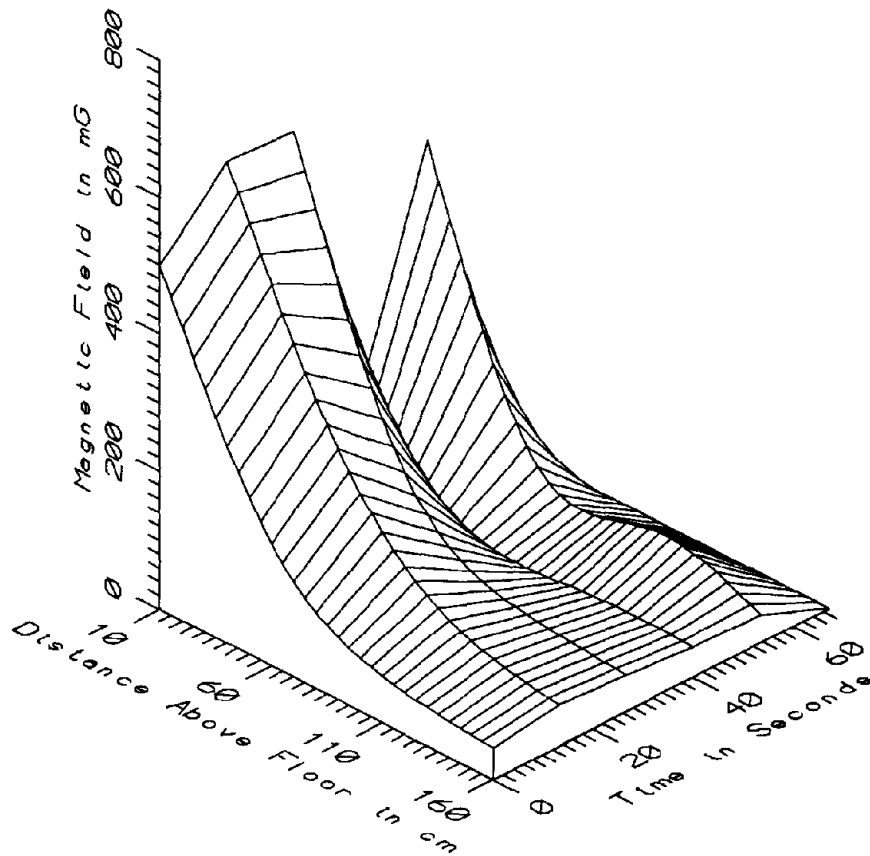

MET014 - NEAR LEFT CENTER DOOR OF CAR 3090 - ALL FREQ, 5-2560Hz

MET014 - NEAR LEFT CENTER DOOR OF CAR 3090				TOTAL OF 6 SAMPLES			
FREQUENCY BAND	HEIGHT ABOVE FLOOR (cm)	MINIMUM MAGNETIC FIELD (mG)	MAXIMUM MAGNETIC FIELD (mG)	AVERAGE MAGNETIC FIELD (mG)	STANDARD DEVIATION (mG)	COEFFICIENT OF VARIATION (%)	
STATIC	10	2431.74	6671.26	4991.41	1695.61	33.97	
	60	1544.30	4536.54	2982.17	1073.39	35.99	
	110	791.07	2186.02	1303.05	591.03	45.36	
	160	470.90	1565.13	971.07	438.45	45.15	
5-45Hz	10	7.66	453.97	124.58	170.63	136.96	
LOW FREQ	60	2.45	219.95	52.50	83.24	158.54	
	110	1.72	83.28	30.35	29.02	95.63	
	160	2.09	52.17	29.59	19.73	66.70	
50-60Hz	10	0.68	50.74	16.39	17.58	107.24	
PWR FREQ	60	0.38	14.35	4.81	4.97	103.21	
	110	0.22	5.10	2.54	1.91	75.13	
	160	0.15	4.91	2.06	1.69	82.36	
65-300Hz	10	0.82	552.39	310.79	238.88	76.86	
PWR HARM	60	0.48	167.92	94.50	75.08	79.45	
	110	0.35	79.75	43.21	31.65	73.25	
	160	0.30	38.89	22.57	14.90	66.01	
305-2560Hz	10	0.82	219.72	118.32	91.13	77.03	
HIGH FREQ	60	0.36	67.27	36.66	30.11	82.12	
	110	0.21	25.02	16.23	11.08	68.30	
	160	0.23	12.99	8.55	5.16	60.37	
5-2560Hz	10	7.78	603.11	393.25	246.72	62.74	
ALL FREQ	60	2.55	265.42	127.67	98.00	76.76	
	110	1.78	99.76	60.86	34.57	56.79	
	160	2.13	59.27	40.78	19.99	49.02	





APPENDIX O

DATASET MET015  
GROSVENOR STATION, NORTH BOUND SIDE OF PLATFORM

Measurement Setup Code:        Staff:     16    Reference: 17  
   Drawing:  A-4

Vehicle Status:                 NA

Measurement Date:               May 19, 1992

Measurement Time:               Start:     10:55:45  
   End:       10:56:55

Number of Samples:               11

Programmed Sample Interval:     5 sec

Actual Sample Interval:         7.0 sec

Frequency Spectrum Parameters

<u>Probe Type:</u>	<u>Wideband</u>	<u>Static</u>
Maximum Frequency (Hz)	2560	100
Minimum Frequency (Hz)	5	0
Spectral Bandwidth (Hz)	5	1

Missing Data: Wideband data from the reference probe

Saturated Data: None

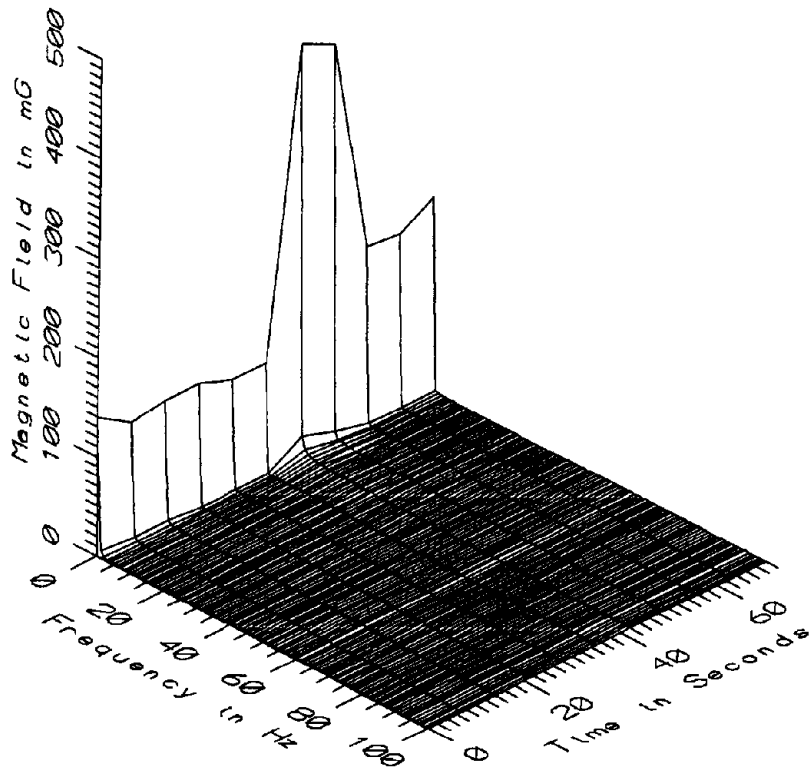

MET015 - 10cm ABOVE PLATFORM AT SAFETY LINE, NORTH BOUND SIDE

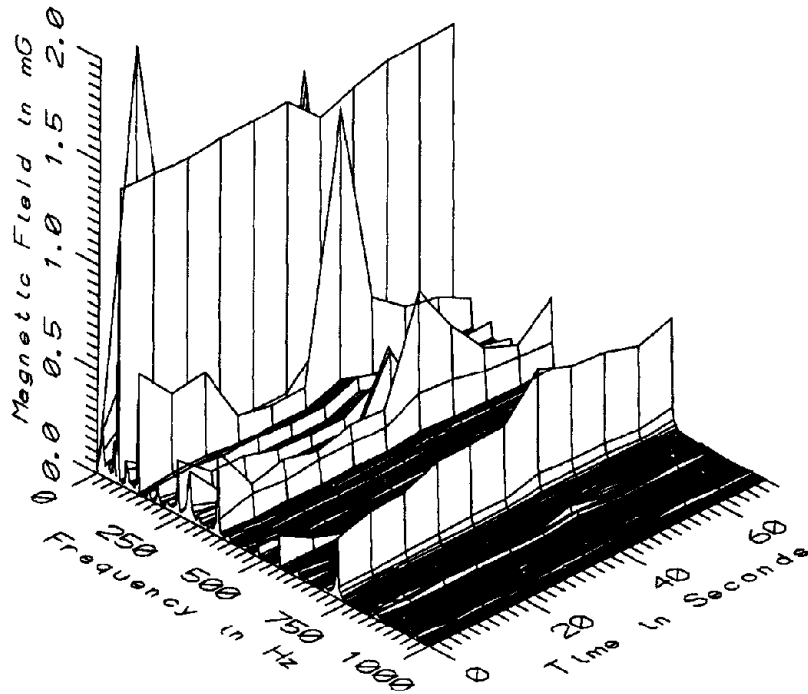

MET015 - 10cm ABOVE PLATFORM AT SAFETY LINE, NORTH BOUND SIDE

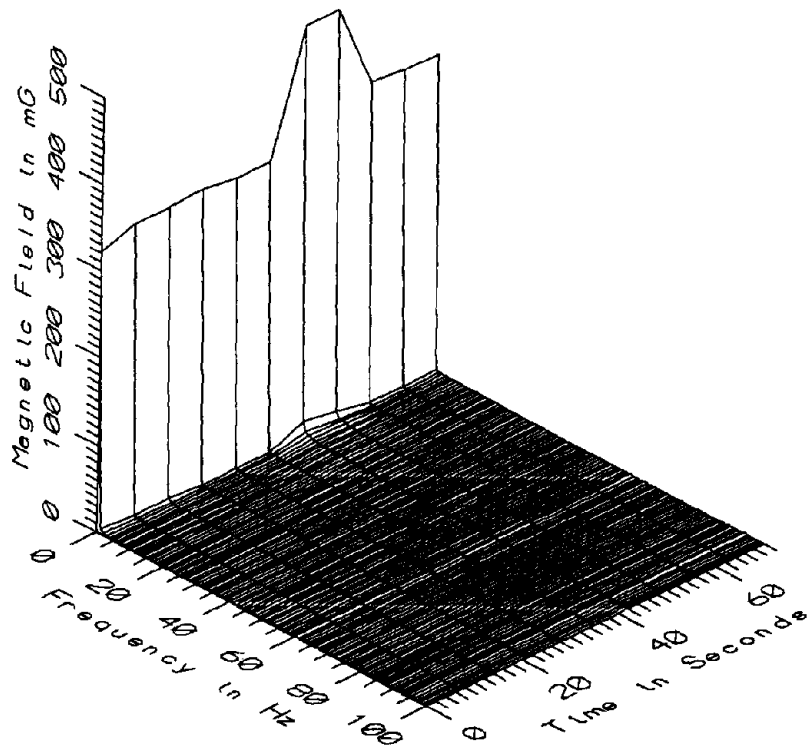

MET015 - 60cm ABOVE PLATFORM AT SAFETY LINE, NORTH BOUND SIDE

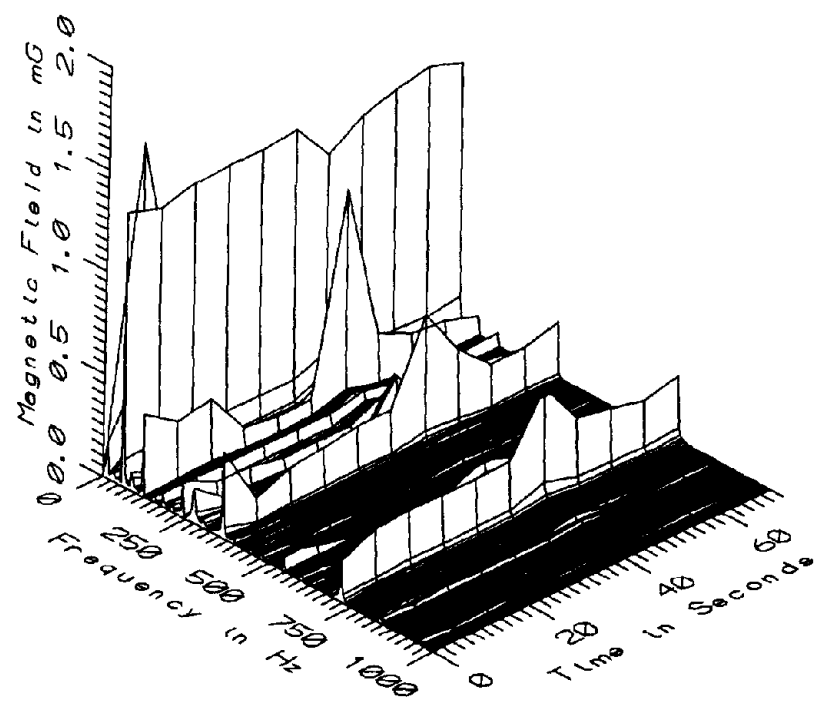

MET015 - 60cm ABOVE PLATFORM AT SAFETY LINE, NORTH BOUND SIDE

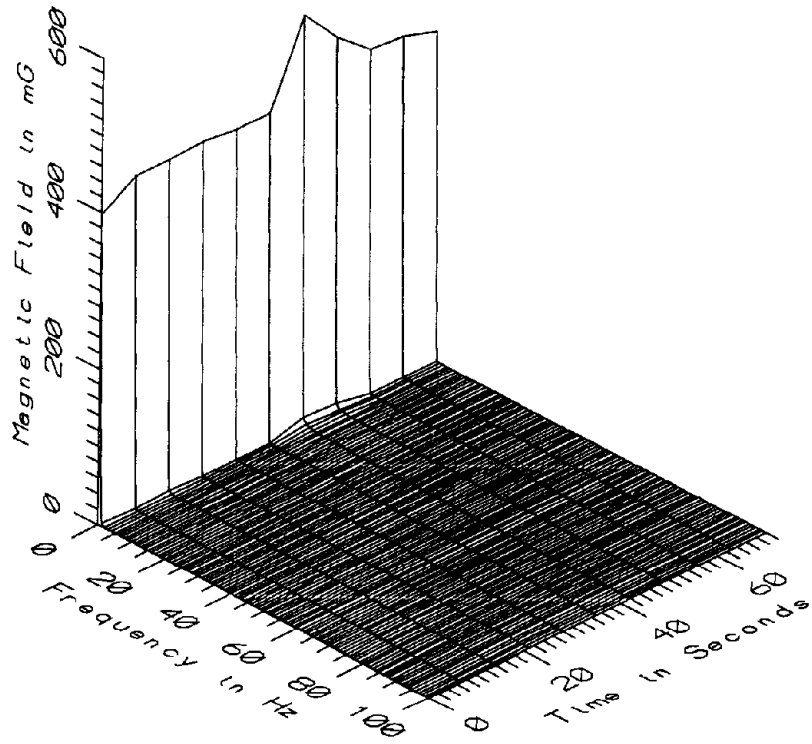

MET015 - 110cm ABOVE PLATFORM AT SAFETY LINE, NORTH BOUND SIDE

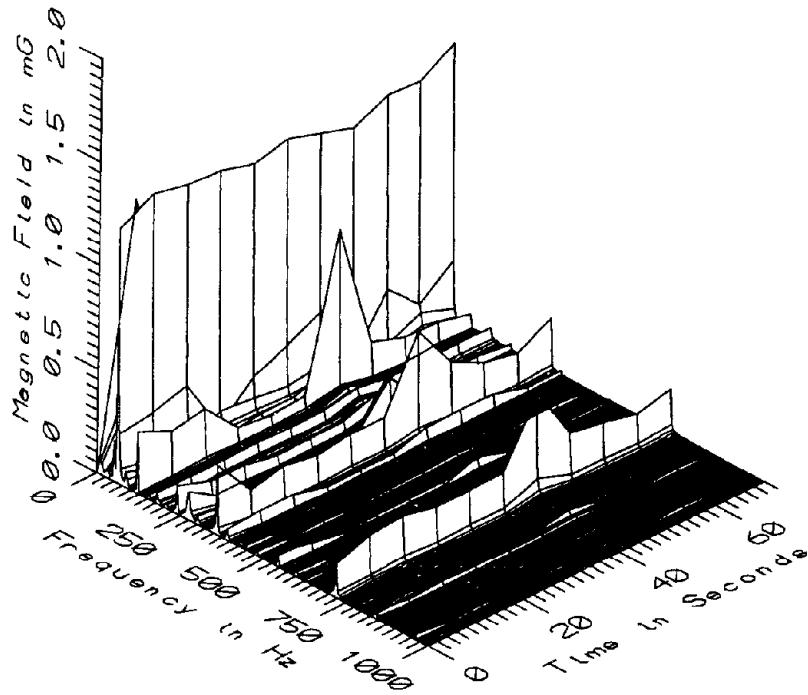

MET015 - 110cm ABOVE PLATFORM AT SAFETY LINE, NORTH BOUND SIDE

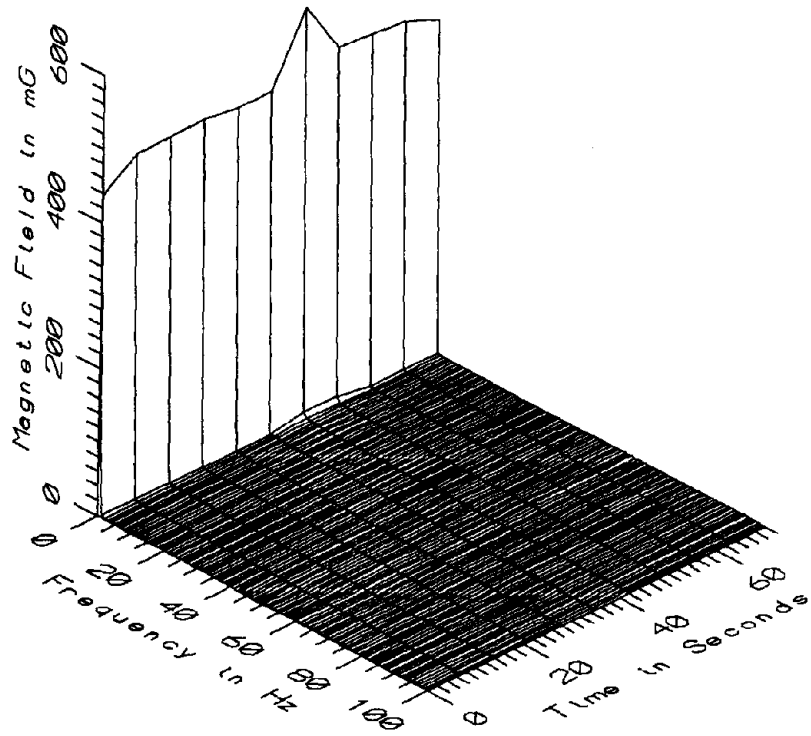

MET015 - 160cm ABOVE PLATFORM AT SAFETY LINE, NORTH BOUND SIDE

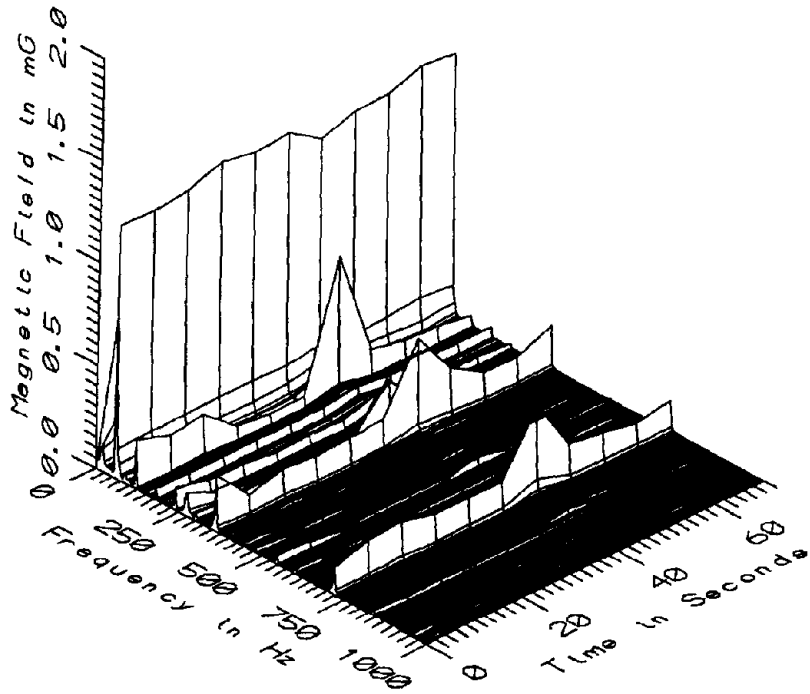

MET015 - 160cm ABOVE PLATFORM AT SAFETY LINE, NORTH BOUND SIDE

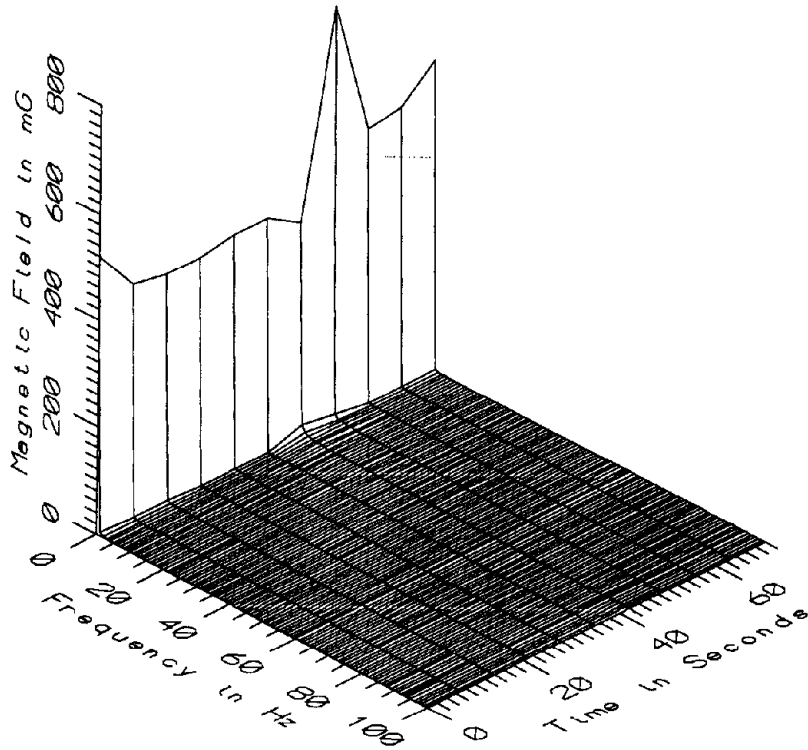

MET015 - REFERENCE PROBE - AT SAFETY LINE, NORTH BOUND SIDE

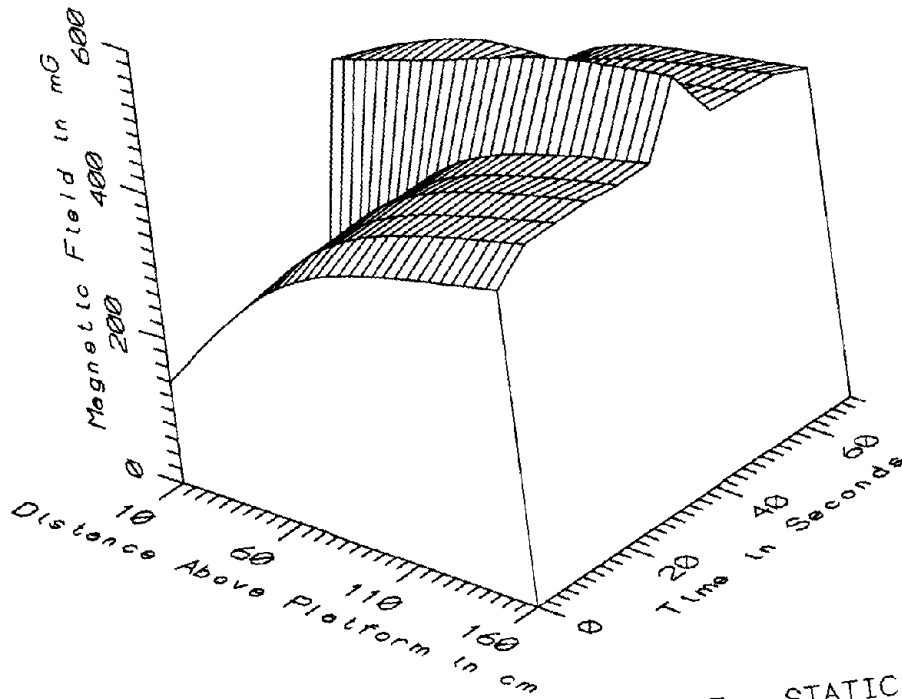

MET015 - AT SAFETY LINE, NORTH BOUND SIDE - STATIC

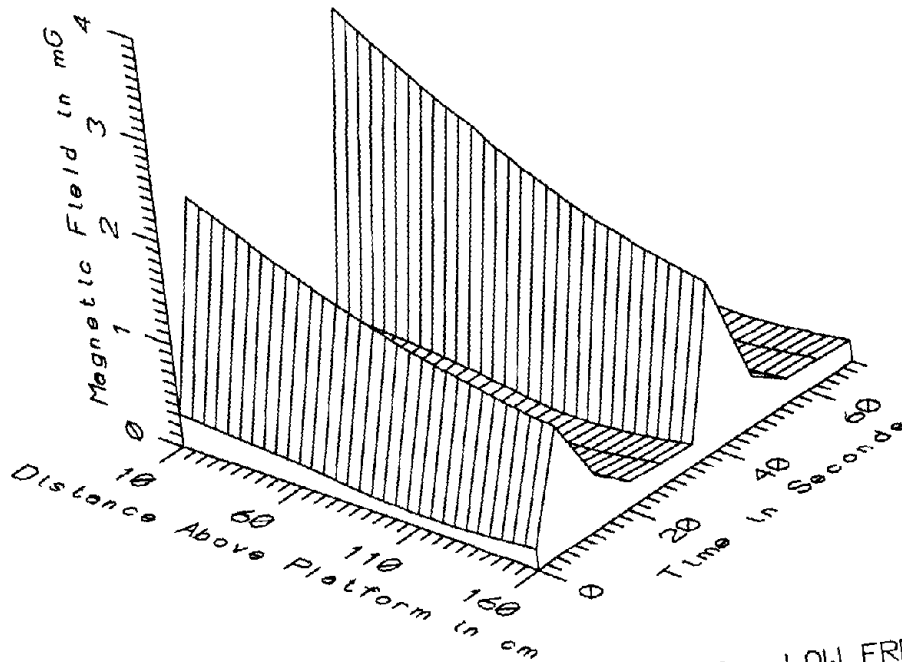

MET015 - AT SAFETY LINE, NORTH BOUND SIDE - LOW FREQ, 5-45Hz

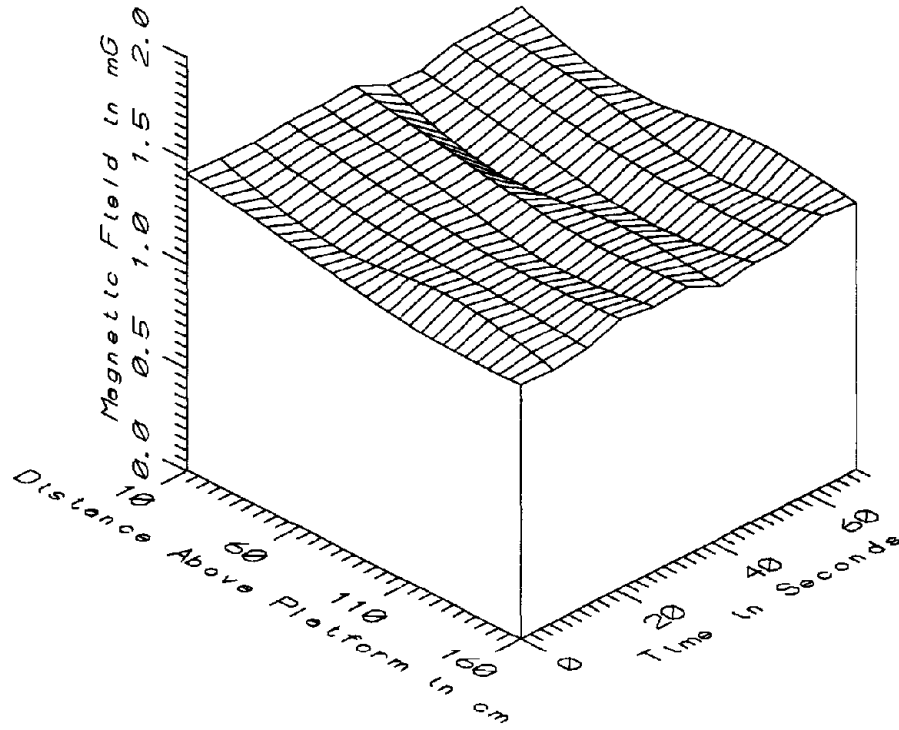

MET015 - AT SAFETY LINE, NORTH BOUND SIDE - POWER FREQ, 50-60Hz

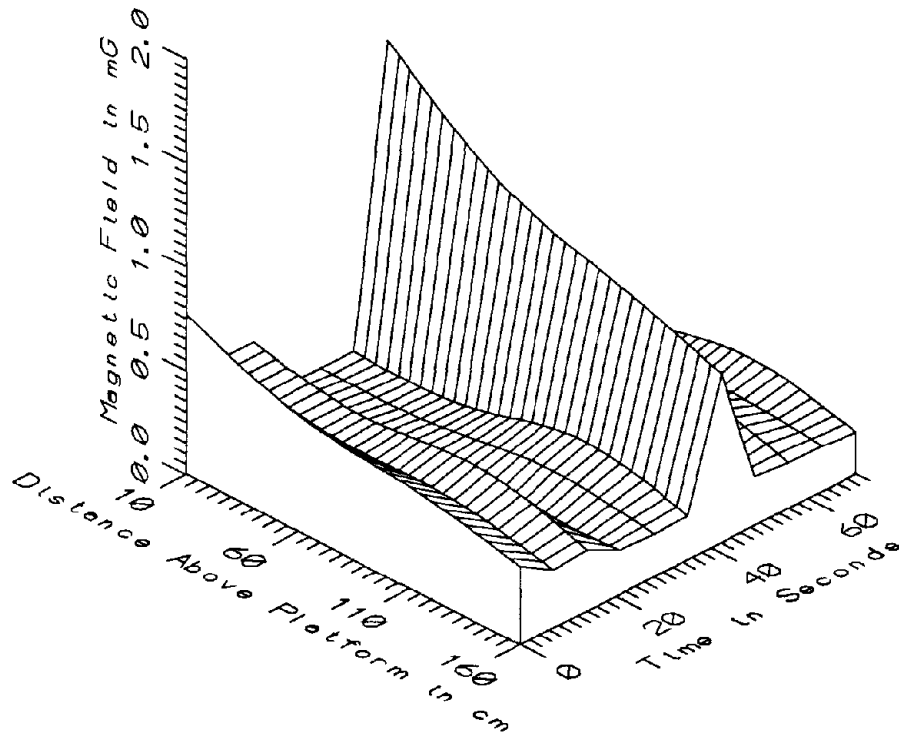

MET015 - AT SAFETY LINE, NORTH BOUND SIDE - POWER HARM, 65-300Hz



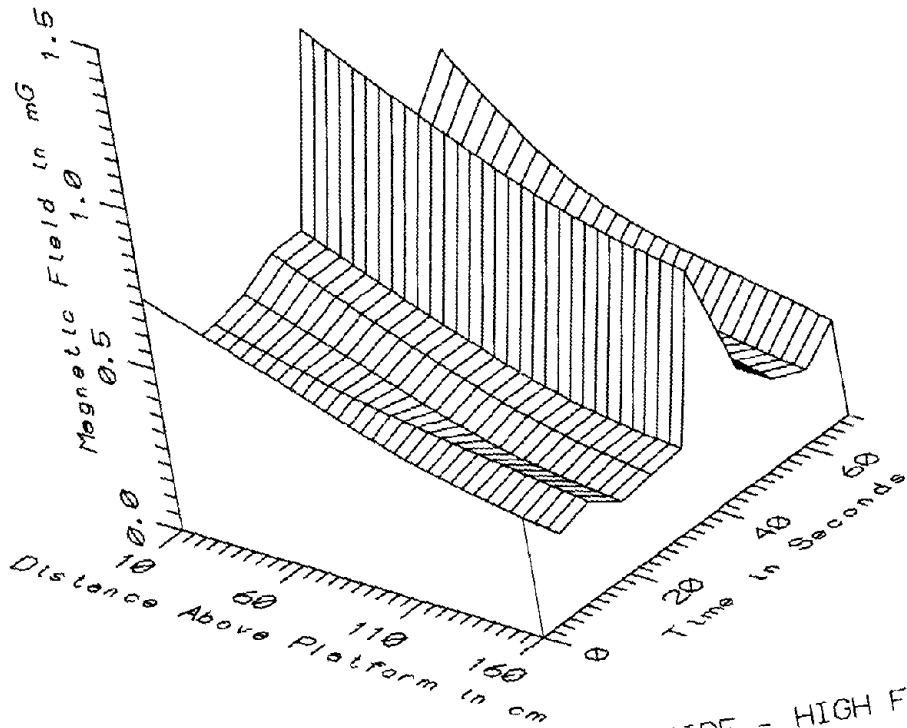

MET015 - AT SAFETY LINE, NORTH BOUND SIDE - HIGH FREQ, 305-2560Hz

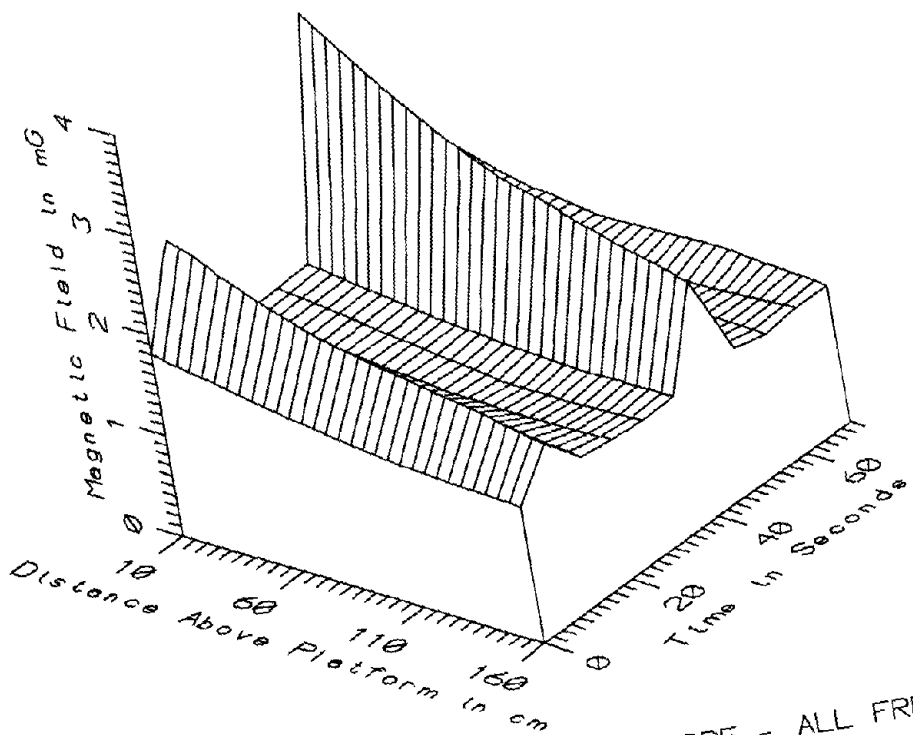

MET015 - AT SAFETY LINE, NORTH BOUND SIDE - ALL FREQ, 5-2560Hz

MET015 - GROSVENOR PLATFORM, NORTH BOUND SIDE		TOTAL OF 11 SAMPLES				
FREQUENCY BAND	HEIGHT ABOVE FLOOR (cm)	MINIMUM MAGNETIC FIELD (mG)	MAXIMUM MAGNETIC FIELD (mG)	AVERAGE MAGNETIC FIELD (mG)	STANDARD DEVIATION (mG)	COEFFICIENT OF VARIATION (%)
STATIC	10	110.95	414.97	189.97	110.97	58.42
	60	322.37	470.42	366.94	53.23	14.51
	110	397.68	528.56	440.08	35.35	8.03
	160	437.43	560.32	476.70	30.50	6.40
5-45HZ LOW FREQ	10	0.24	3.07	0.86	0.96	111.99
	60	0.18	2.40	0.65	0.75	115.31
	110	0.07	1.88	0.48	0.61	128.01
	160	0.20	1.59	0.48	0.47	97.24
50-60HZ PWR FREQ	10	1.36	1.45	1.42	0.03	1.91
	60	1.22	1.35	1.31	0.04	3.23
	110	1.18	1.34	1.27	0.04	3.43
	160	1.22	1.31	1.26	0.03	2.62
65-300HZ PWR HARM	10	0.18	1.60	0.46	0.42	91.77
	60	0.19	1.19	0.37	0.30	79.63
	110	0.19	1.00	0.38	0.22	59.32
	160	0.20	0.81	0.30	0.18	60.64
305-2560HZ HIGH FREQ	10	0.49	1.15	0.69	0.19	28.00
	60	0.36	0.96	0.50	0.17	34.12
	110	0.27	0.81	0.38	0.15	40.37
	160	0.21	0.72	0.31	0.15	46.87
5-2560HZ ALL FREQ	10	1.56	3.90	2.00	0.71	35.61
	60	1.40	3.10	1.70	0.52	30.53
	110	1.30	2.60	1.54	0.40	25.86
	160	1.32	2.28	1.48	0.29	19.65

APPENDIX P

DATASET MET017  
GROSVENOR STATION, SOUTH BOUND SIDE OF PLATFORM

Measurement Setup Code:        Staff:    18    Reference: 19  
   Drawing:  A-4

Vehicle Status:                    NA

Measurement Date:                May 19, 1992

Measurement Time:                Start:    10:59:44  
   End:      11:02:08

Number of Samples:                23

Programmed Sample Interval:    5 sec

Actual Sample Interval:         6.5 sec

Frequency Spectrum Parameters

<u>Probe Type:</u>	<u>Wideband</u>	<u>Static</u>
Maximum Frequency (Hz)	2560	100
Minimum Frequency (Hz)	5	0
Spectral Bandwidth (Hz)	5	1

Missing Data: Wideband data from the reference probe

Saturated Data - Wideband:	<u>Sensor</u>	<u>Sample</u>	<u>Time (sec)</u>
	60cm	2	7
	160cm	2	7

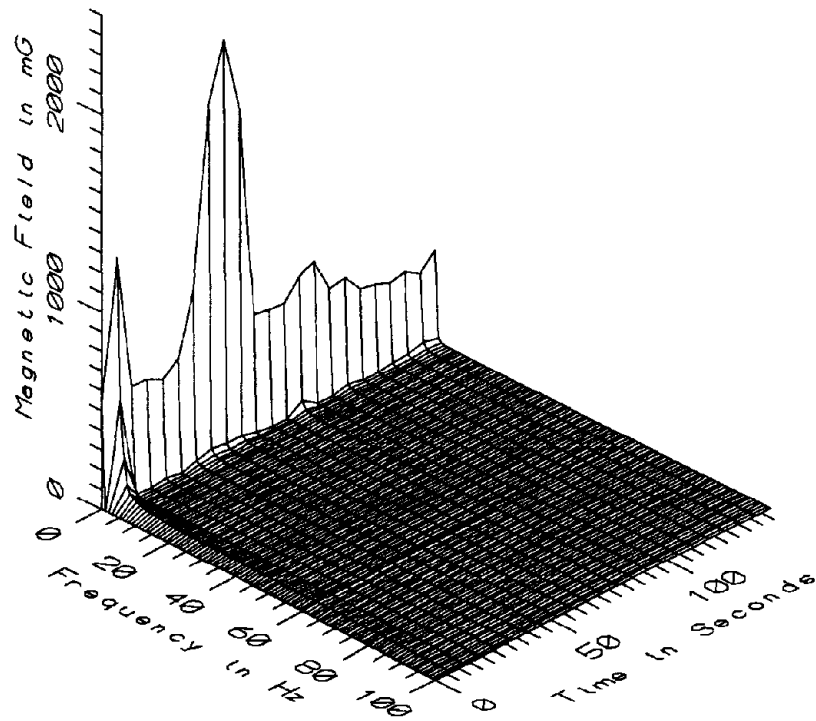

MET017 - 10cm ABOVE PLATFORM AT SAFETY LINE, SOUTH BOUND SIDE

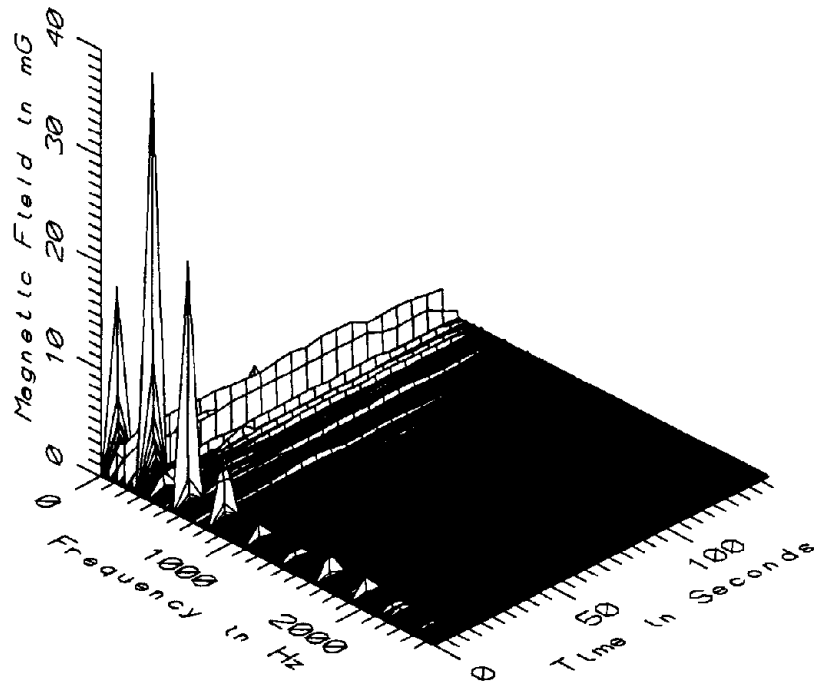

MET017 - 10cm ABOVE PLATFORM AT SAFETY LINE, SOUTH BOUND SIDE

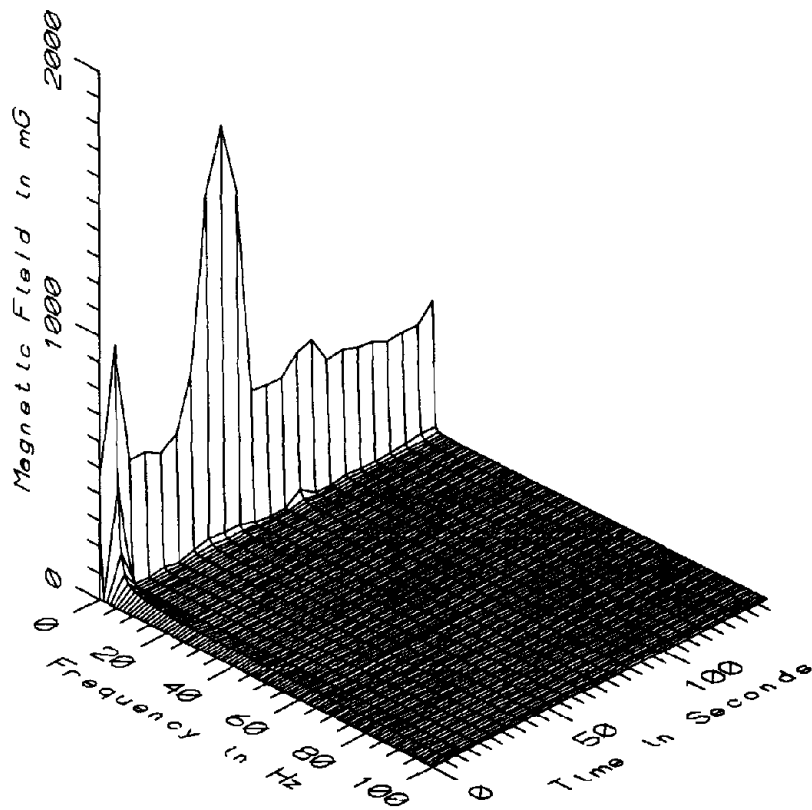

MET017 - 60cm ABOVE PLATFORM AT SAFETY LINE, SOUTH BOUND SIDE

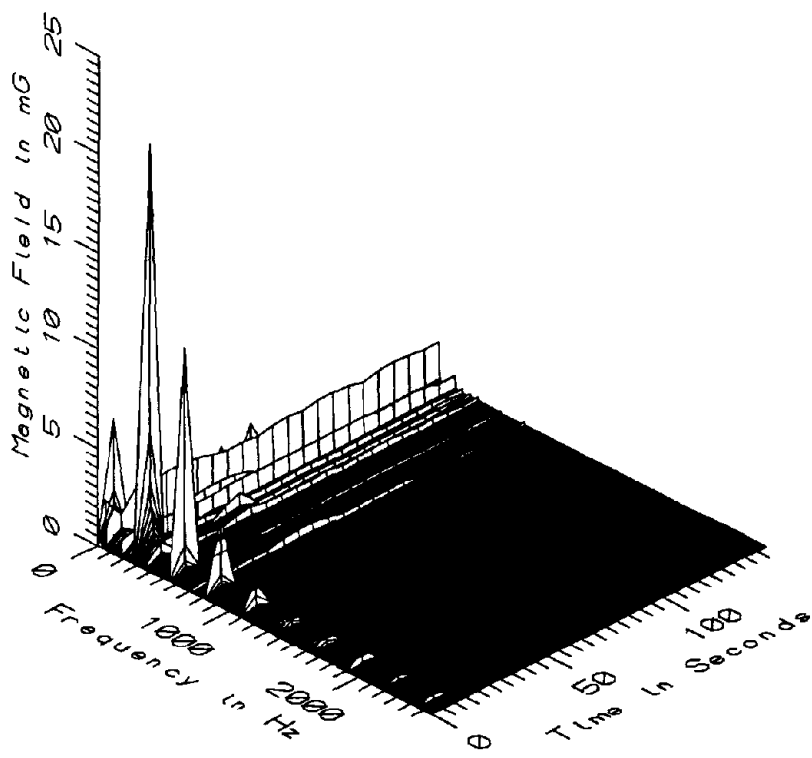

MET017 - 60cm ABOVE PLATFORM AT SAFETY LINE, SOUTH BOUND SIDE

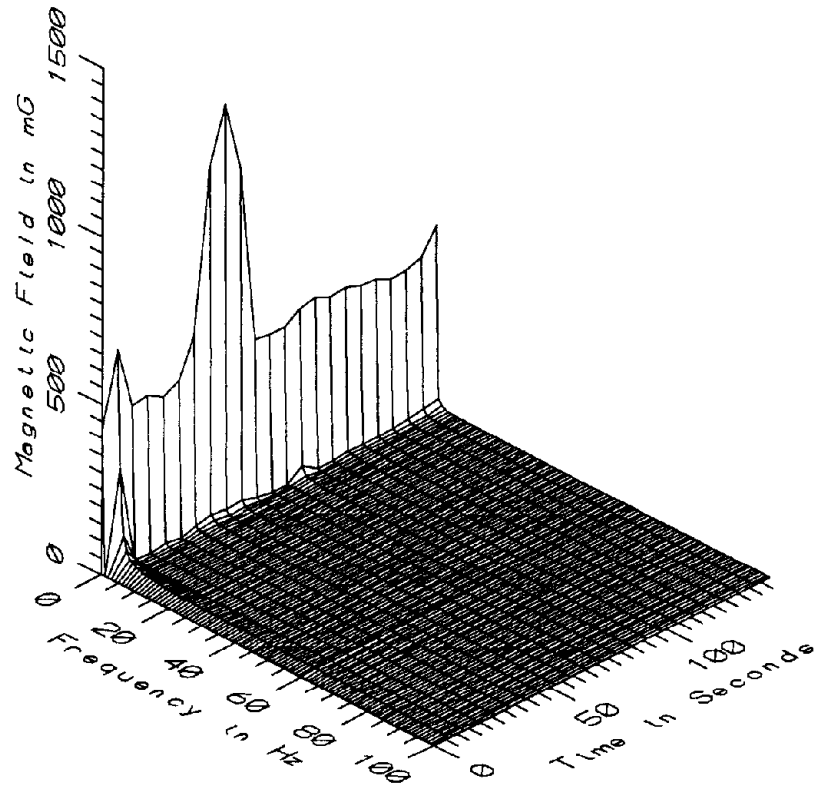

MET017 - 110cm ABOVE PLATFORM AT SAFETY LINE, SOUTH BOUND SIDE

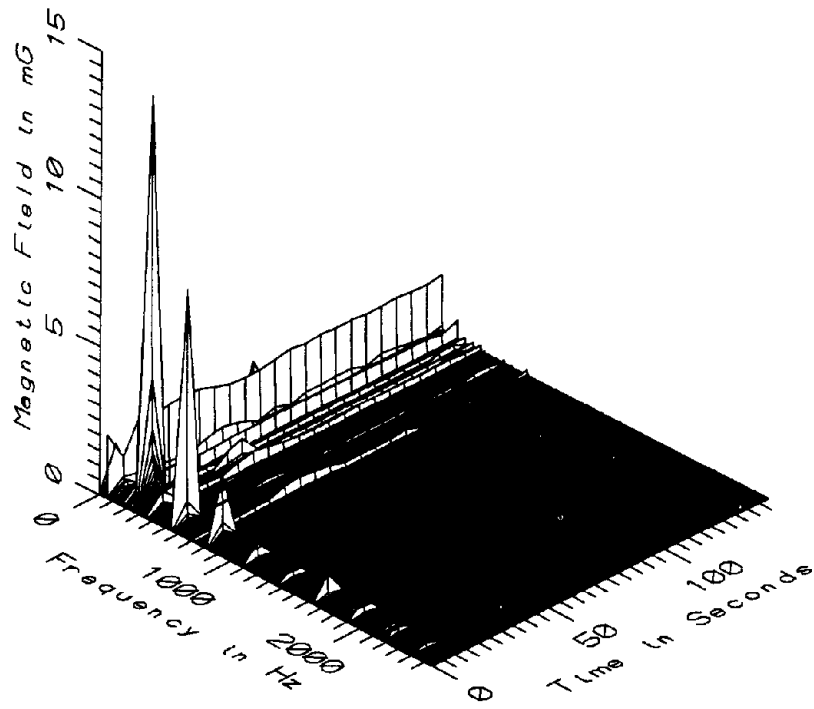

MET017 - 110cm ABOVE PLATFORM AT SAFETY LINE, SOUTH BOUND SIDE

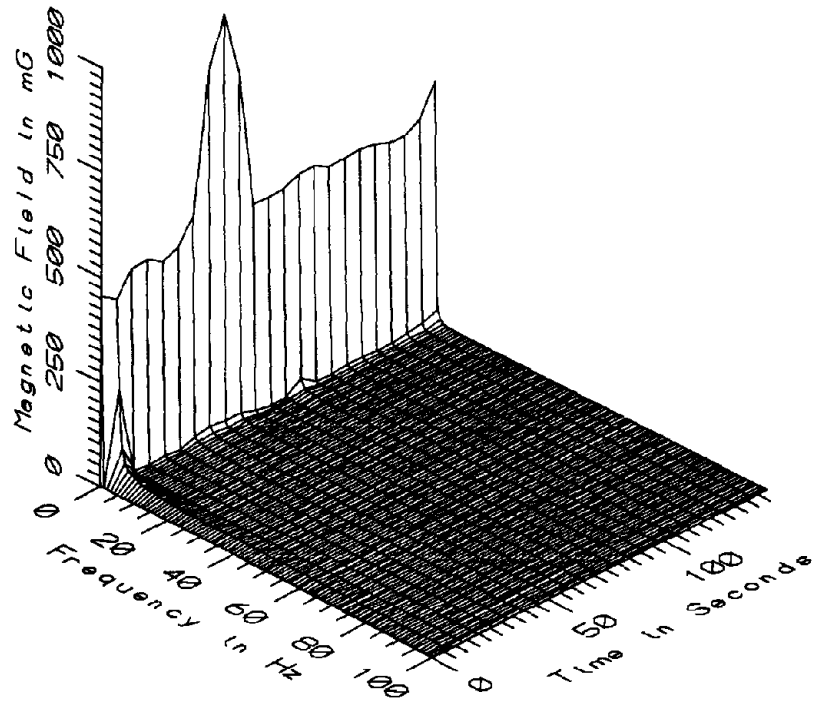

MET017 - 160cm ABOVE PLATFORM AT SAFETY LINE, SOUTH BOUND SIDE

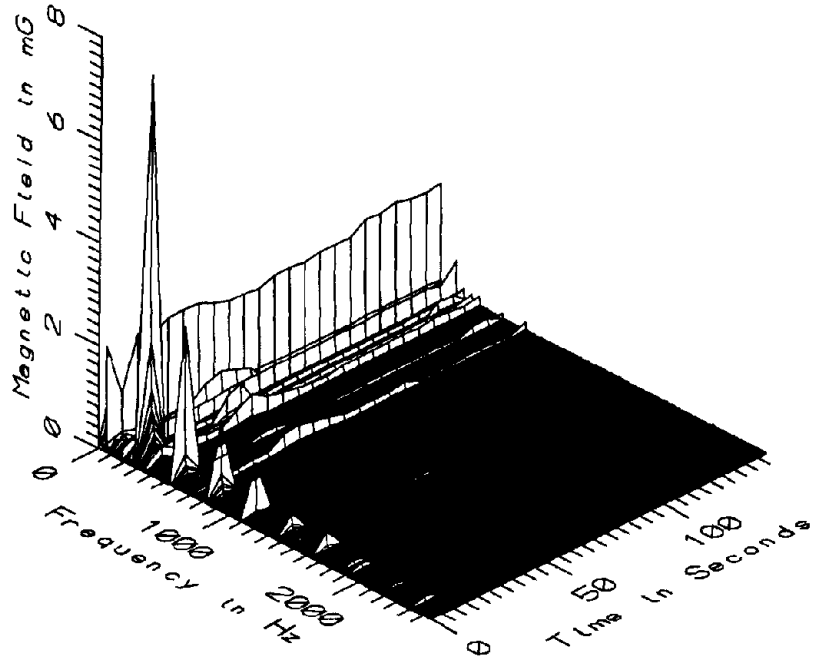

MET017 - 160cm ABOVE PLATFORM AT SAFETY LINE, SOUTH BOUND SIDE

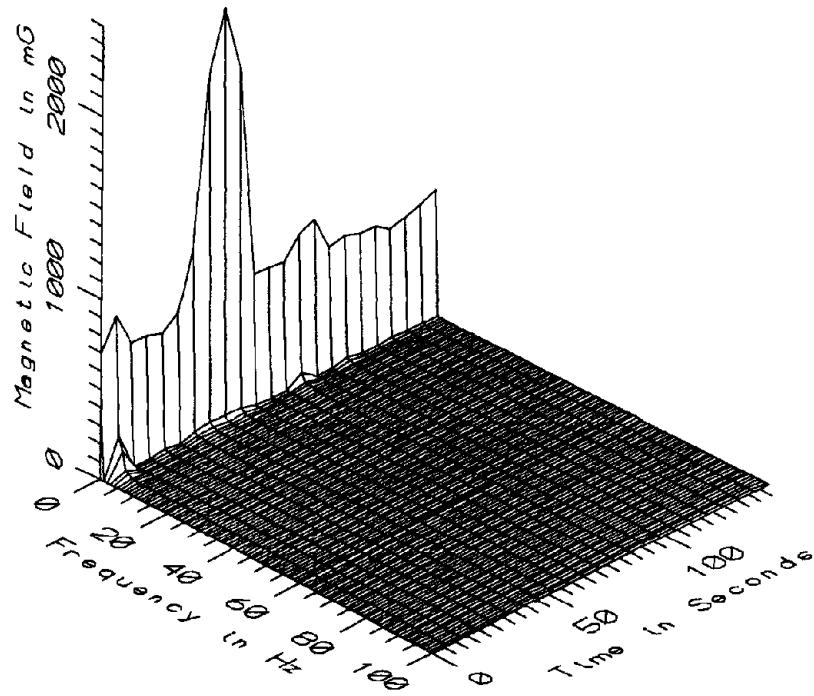

MET017 - REFERENCE PROBE - AT SAFETY LINE, SOUTH BOUND SIDE



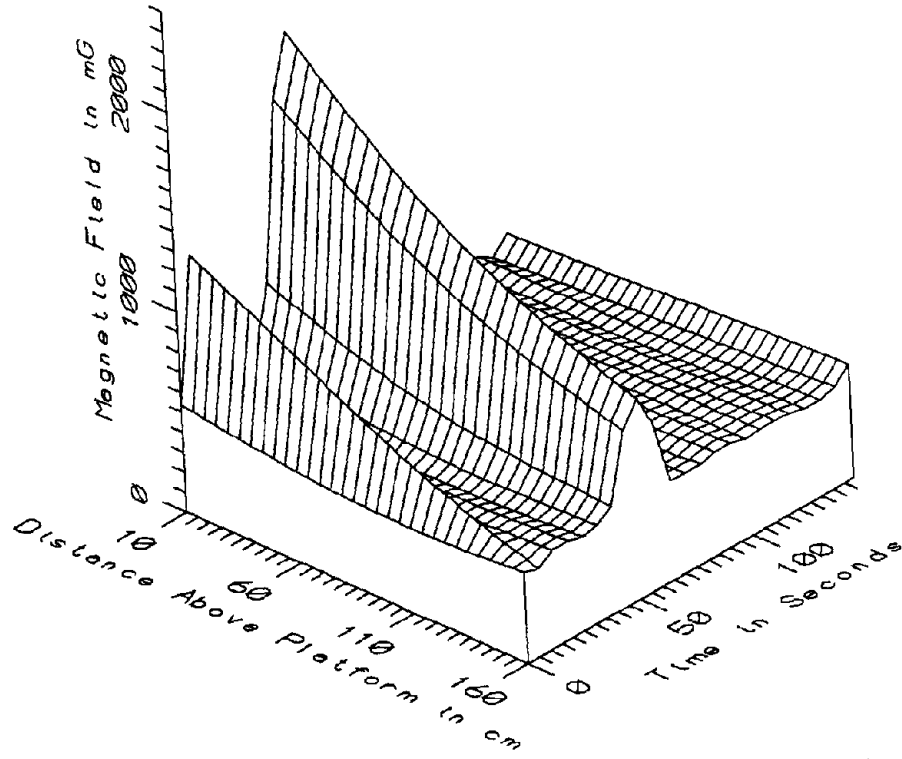

MET017 - AT SAFETY LINE, SOUTH BOUND SIDE - STATIC

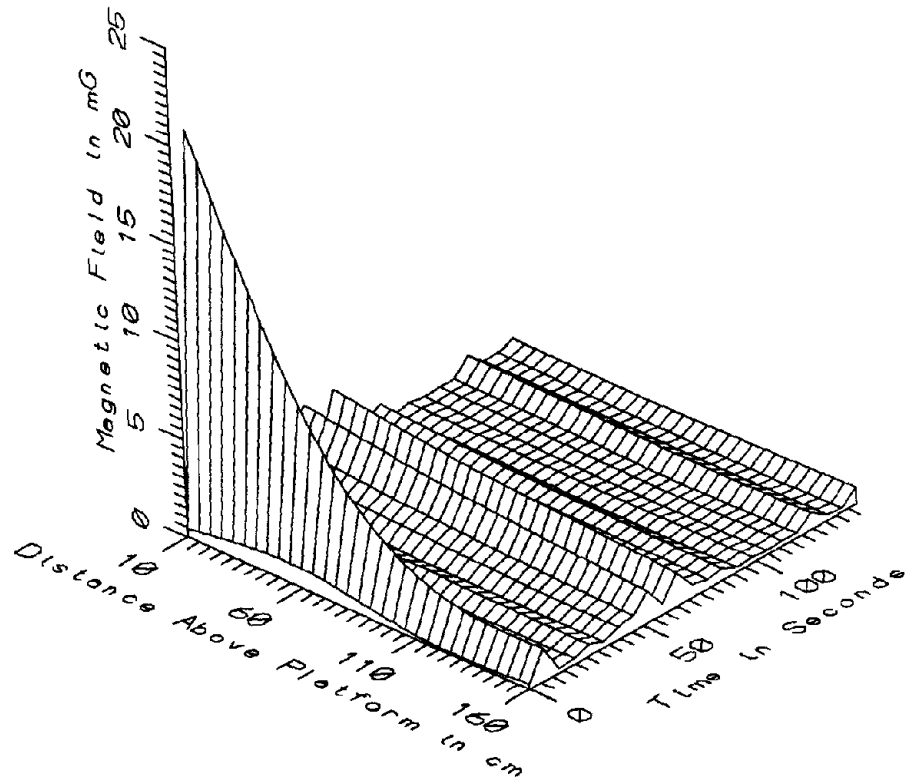

MET017 - AT SAFETY LINE, SOUTH BOUND SIDE - LOW FREQ, 5-45Hz

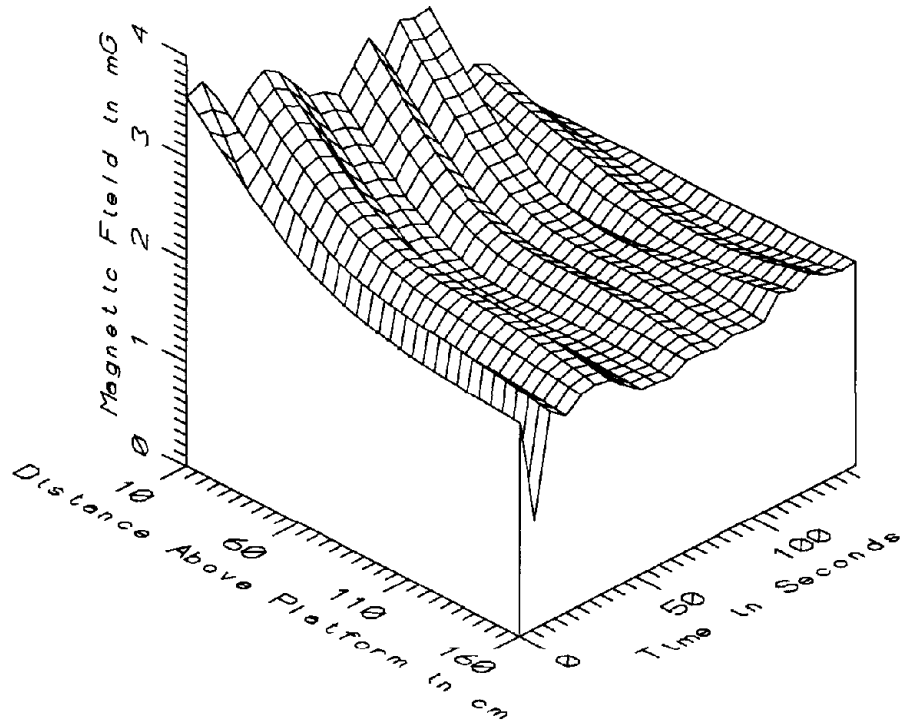

MET017 - AT SAFETY LINE, SOUTH BOUND SIDE - POWER FREQ, 50-60Hz

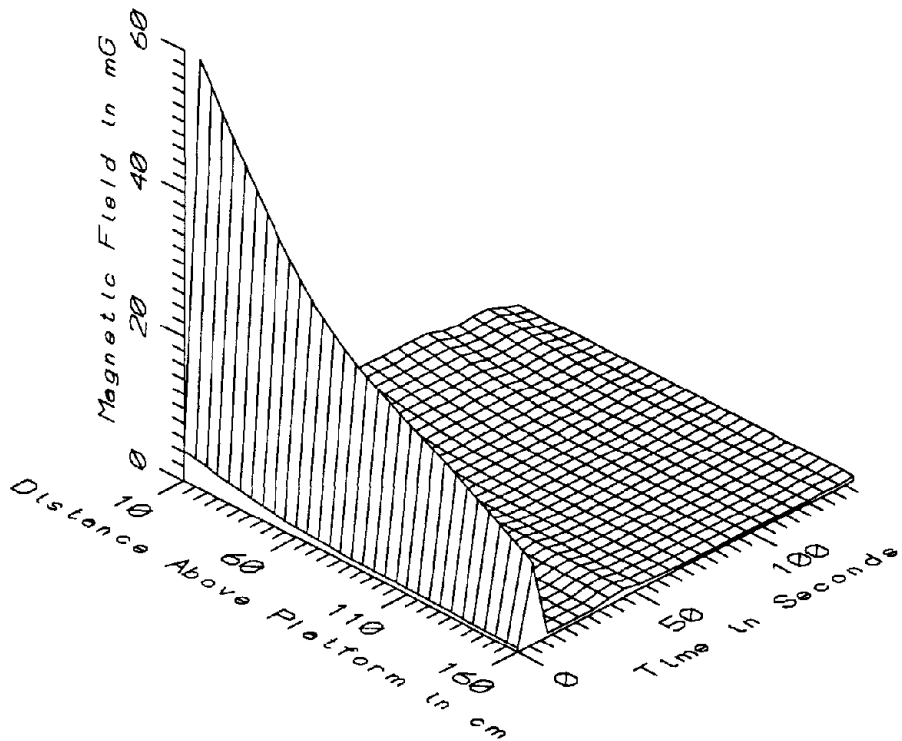

MET017 - AT SAFETY LINE, SOUTH BOUND SIDE - POWER HARM, 65-300Hz

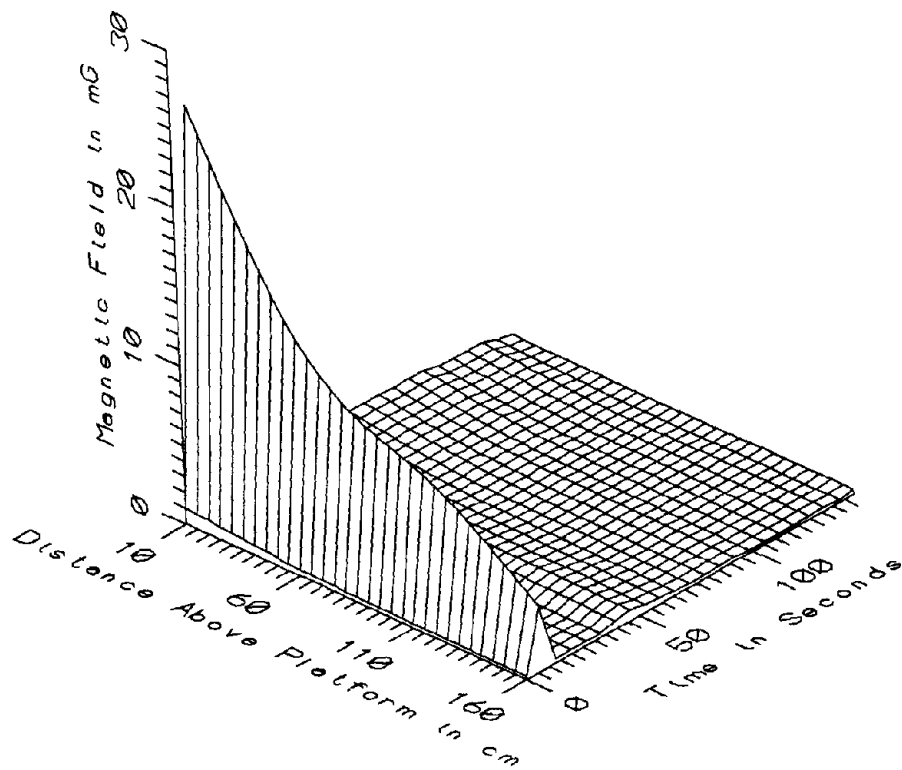

MET017 - AT SAFETY LINE, SOUTH BOUND SIDE - HIGH FREQ, 305-2560Hz

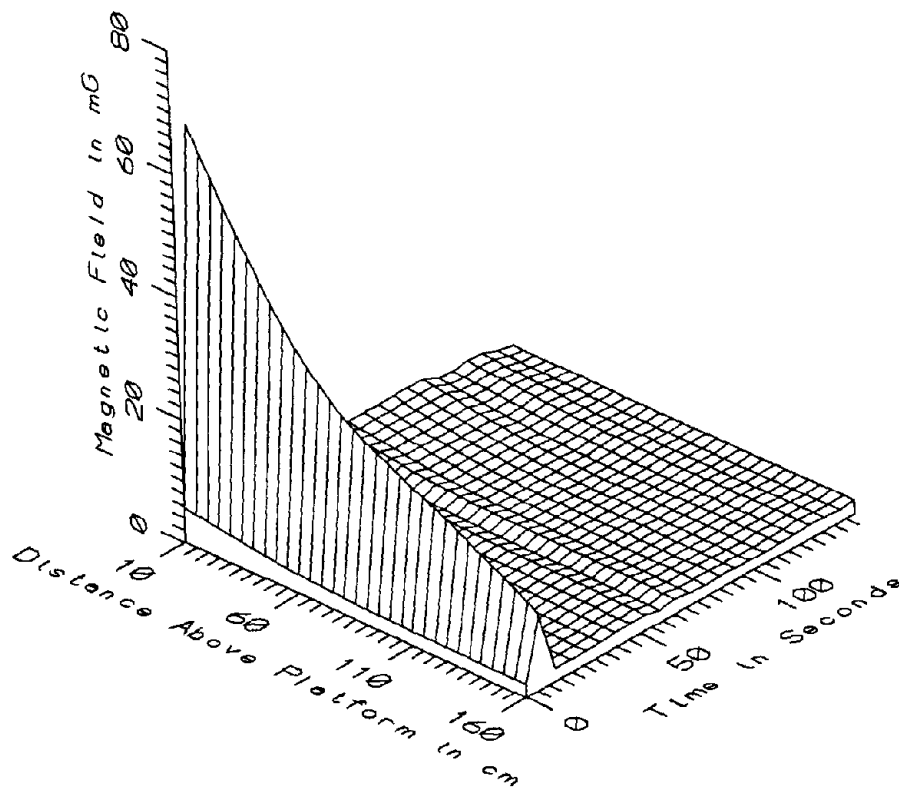

MET017 - AT SAFETY LINE, SOUTH BOUND SIDE - ALL FREQ, 5-2560Hz

MET017 - GROSVENOR PLATFORM, SOUTH BOUND SIDE		TOTAL OF 23 SAMPLES				
FREQUENCY BAND	HEIGHT ABOVE FLOOR (cm)	MINIMUM MAGNETIC FIELD (mG)	MAXIMUM MAGNETIC FIELD (mG)	AVERAGE MAGNETIC FIELD (mG)	STANDARD DEVIATION (mG)	COEFFICIENT OF VARIATION (%)
STATIC	10	384.32	2065.36	749.57	472.84	63.08
	60	424.06	1562.41	626.72	326.61	52.11
	110	424.42	1217.60	562.90	218.02	38.73
	160	431.80	983.98	544.17	142.62	26.21
5-45Hz LOW FREQ	10	0.32	20.41	1.83	4.13	226.15
	60	0.23	7.63	1.06	1.56	147.26
	110	0.13	2.25	0.65	0.63	95.57
	160	0.22	1.67	0.61	0.46	75.27
50-60Hz PWR FREQ	10	1.96	3.67	3.01	0.47	15.66
	60	1.85	2.56	2.13	0.20	9.57
	110	1.26	2.24	1.93	0.20	10.24
	160	1.04	2.08	1.88	0.21	11.34
65-300Hz PWR HARM	10	0.78	57.74	5.59	11.41	204.00
	60	0.77	31.96	2.53	6.42	253.55
	110	0.56	20.71	1.62	4.17	256.79
	160	0.44	11.22	1.03	2.23	215.62
305-2560Hz HIGH FREQ	10	0.44	25.97	2.24	5.18	230.79
	60	0.32	13.19	1.05	2.65	252.28
	110	0.25	9.00	0.74	1.80	242.29
	160	0.20	4.03	0.47	0.79	167.66
5-2560Hz ALL FREQ	10	2.28	66.62	7.41	12.95	174.62
	60	2.16	35.45	4.11	6.84	166.33
	110	1.96	22.73	3.16	4.27	135.32
	160	1.92	12.08	2.58	2.08	80.76

APPENDIX Q

DATASET MET018  
GROSVENOR STATION, SOUTH BOUND SIDE OF PLATFORM

Measurement Setup Code:        Staff:    20    Reference: 17  
   Drawing:  A-4

Vehicle Status:                NA

Measurement Date:              May 19, 1992

Measurement Time:              Start:    11:04:45  
   End:      11:08:20

Number of Samples:              34

Programmed Sample Interval:    5 sec

Actual Sample Interval:        6.5 sec

Frequency Spectrum Parameters

<u>Probe Type:</u>	<u>Wideband</u>	<u>Static</u>
Maximum Frequency (Hz)	2560	100
Minimum Frequency (Hz)	5	0
Spectral Bandwidth (Hz)	5	1

Missing Data: Wideband data from the reference probe

Saturated Data: None

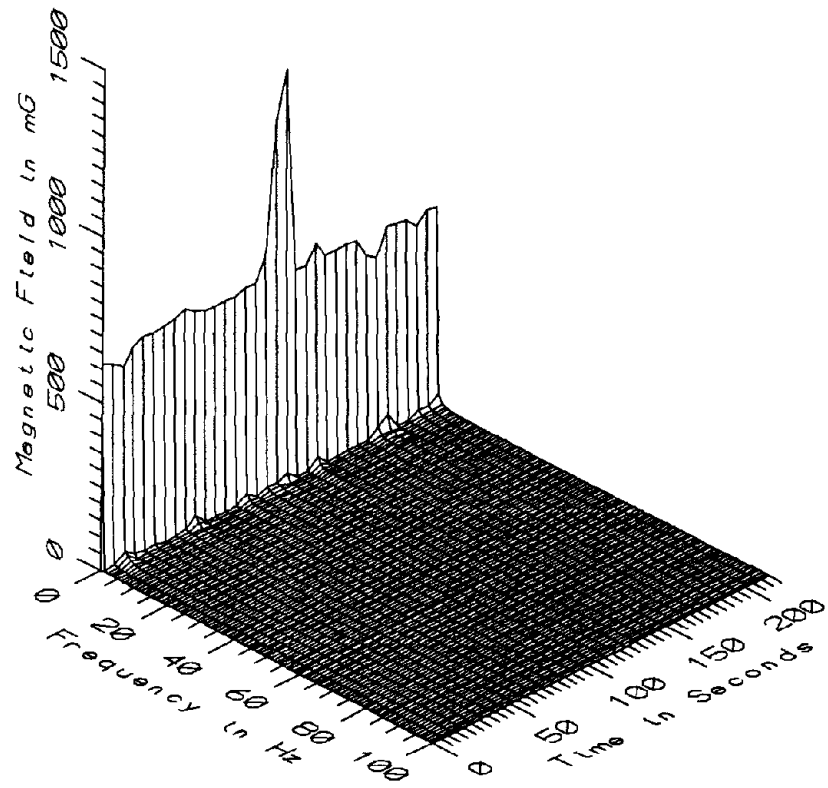

MET018 - 0cm FROM SAFETY LINE, 1M ABOVE PLATFORM, SOUTH BOUND SIDE

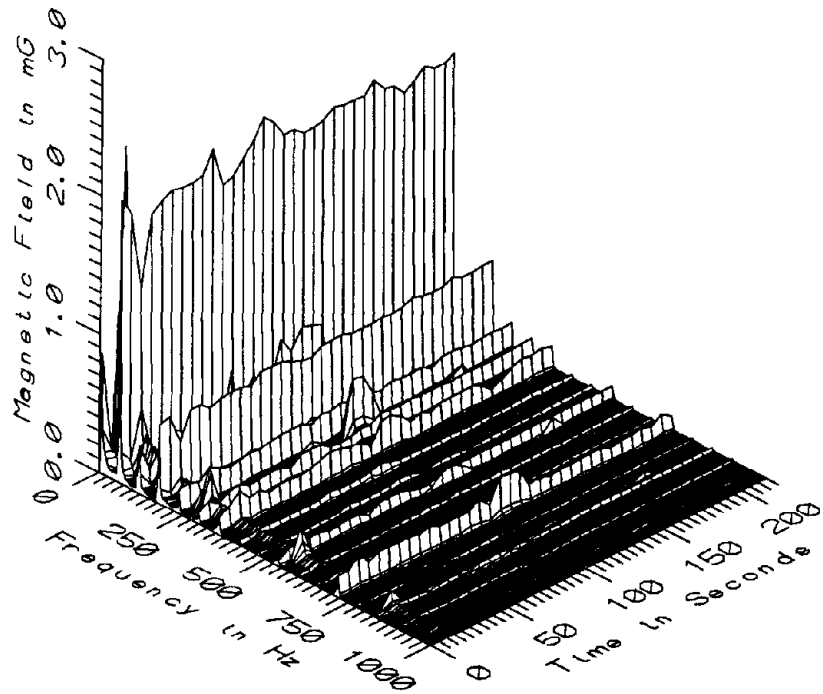

MET018 - 0cm FROM SAFETY LINE, 1M ABOVE PLATFORM, SOUTH BOUND SIDE

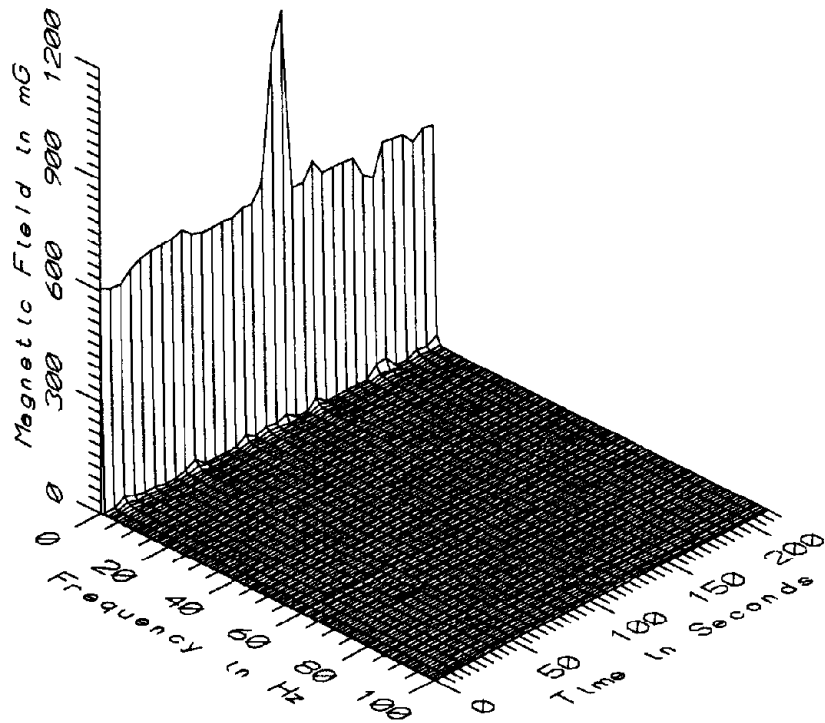

MET018 - 50cm FROM SAFETY LINE, 1M ABOVE PLATFORM, SOUTH BOUND SIDE

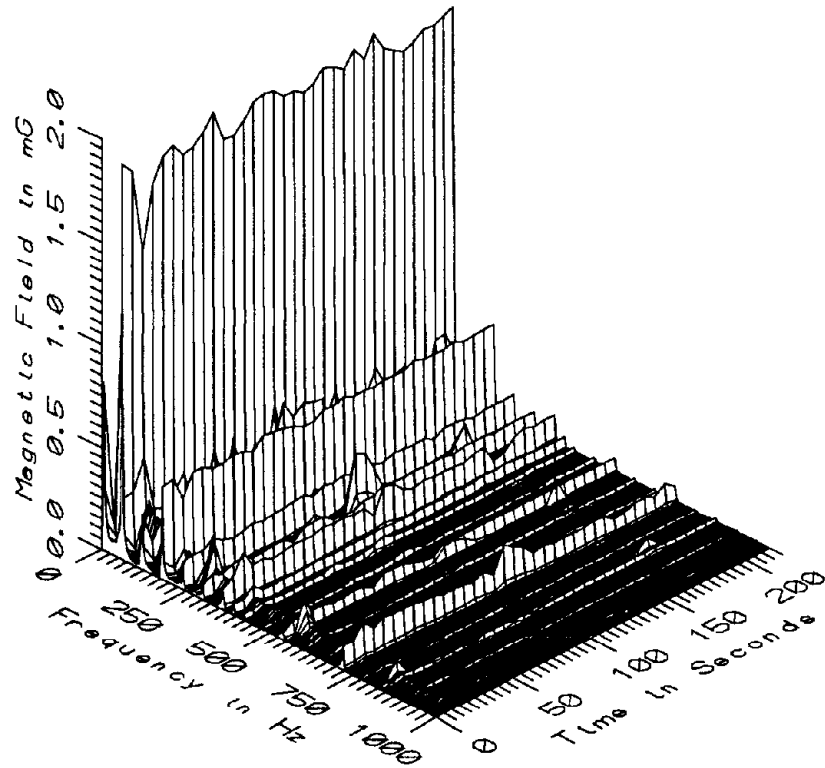

MET018 - 50cm FROM SAFETY LINE, 1M ABOVE PLATFORM, SOUTH BOUND SIDE

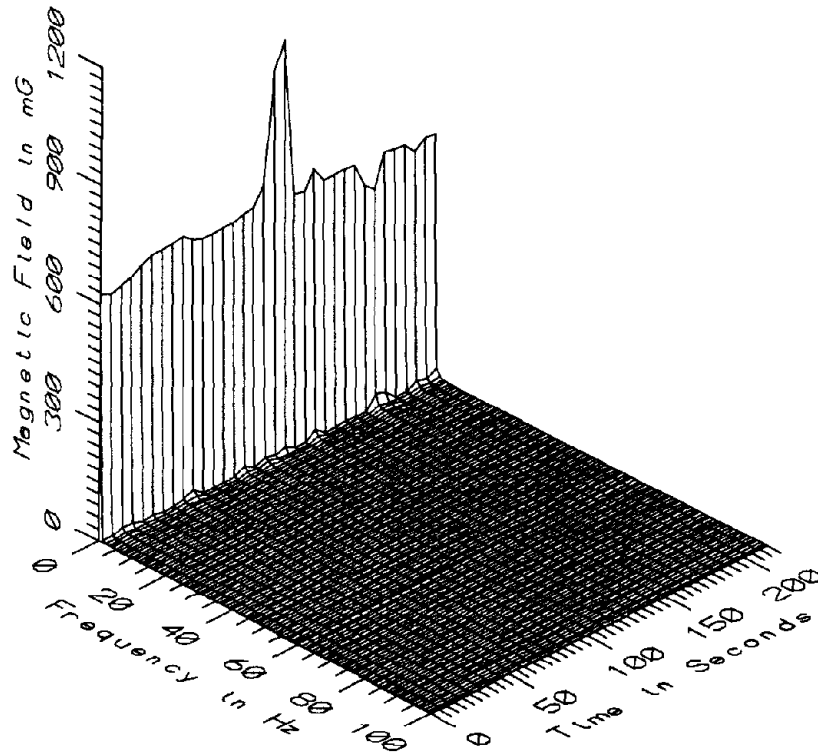

MET018 - 100cm FROM SAFETY LINE, 1M ABOVE PLATFORM, SOUTH BOUND SIDE

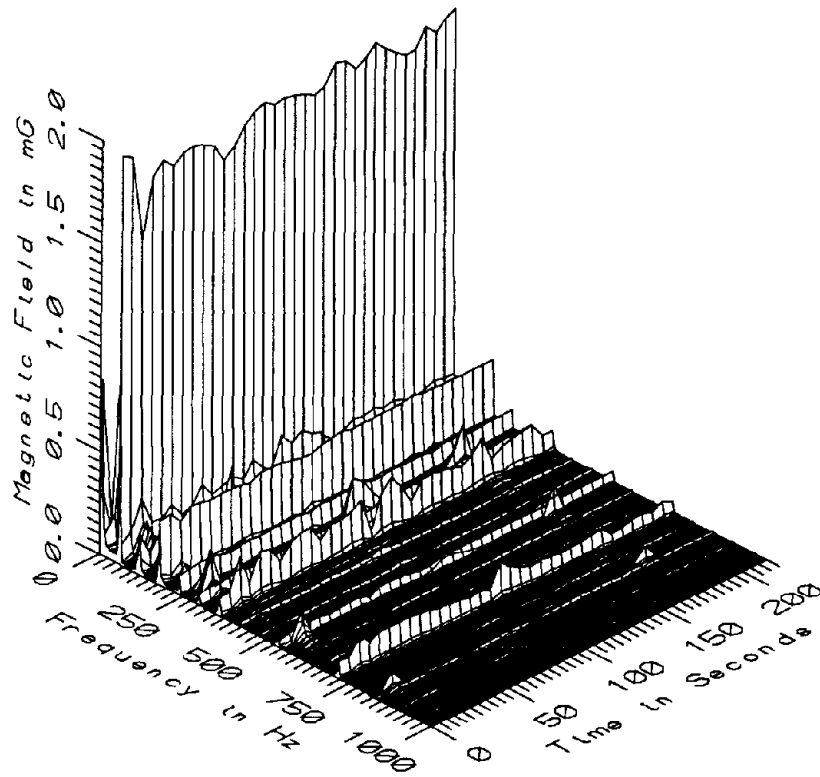

MET018 - 100cm FROM SAFETY LINE, 1M ABOVE PLATFORM, SOUTH BOUND SIDE



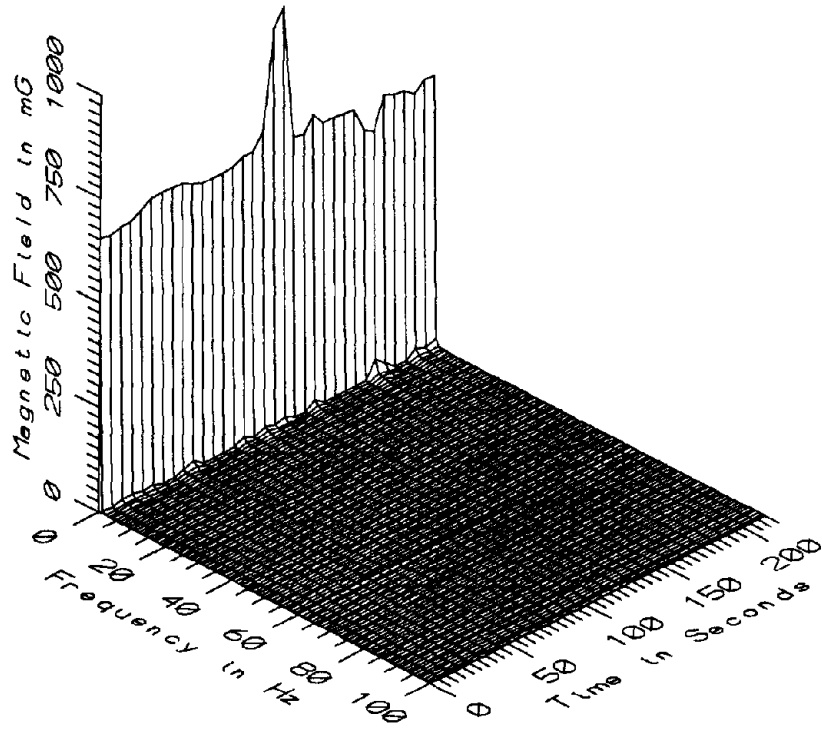

MET018 - 150cm FROM SAFETY LINE, 1M ABOVE PLATFORM, SOUTH BOUND SIDE

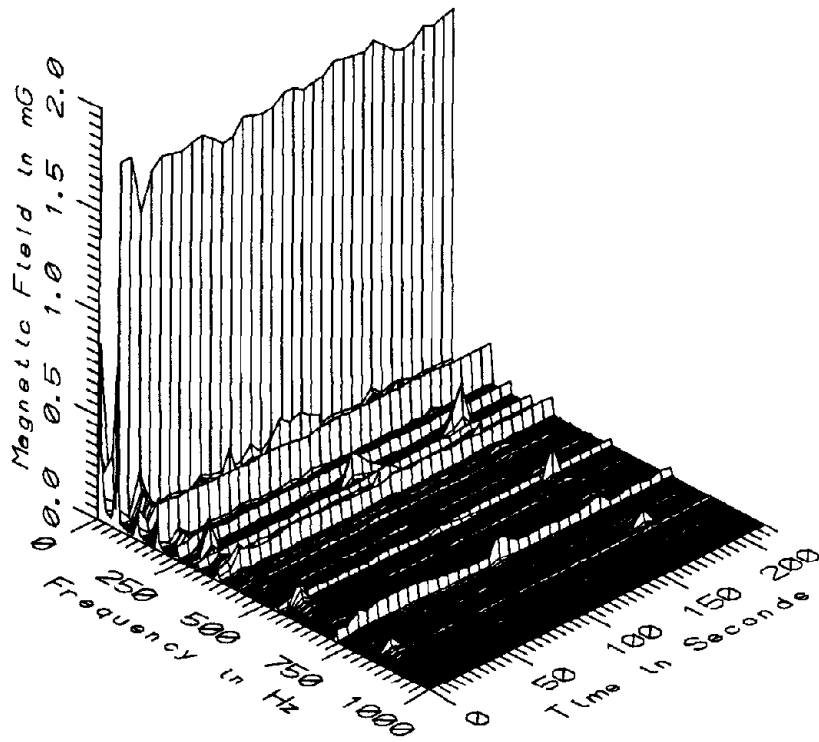

MET018 - 150cm FROM SAFETY LINE, 1M ABOVE PLATFORM, SOUTH BOUND SIDE

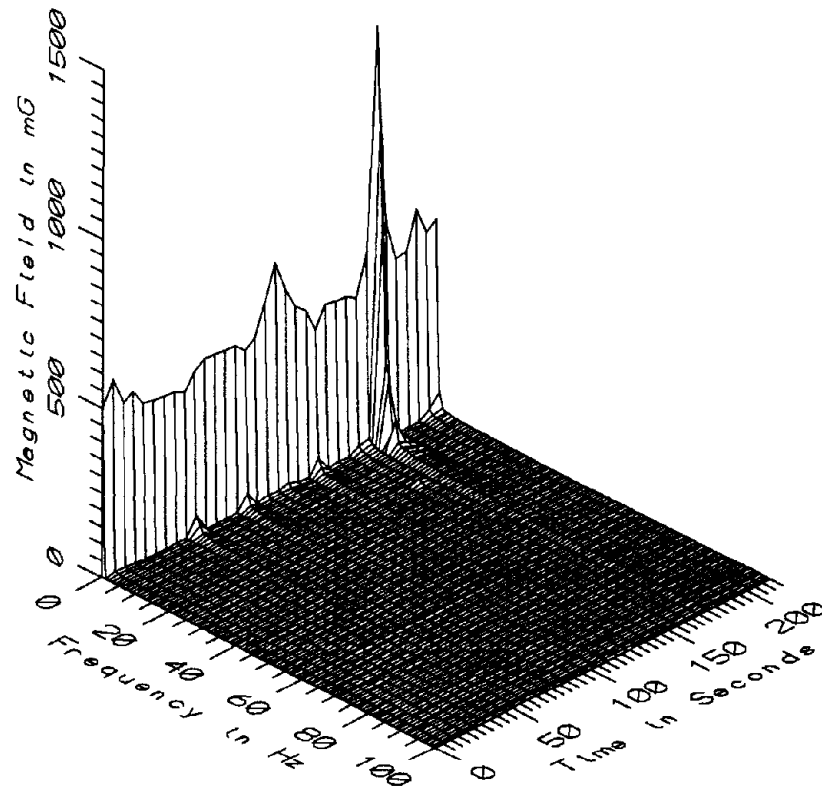

MET018 - REFERENCE PROBE - AT SAFETY LINE, NORTH BOUND SIDE

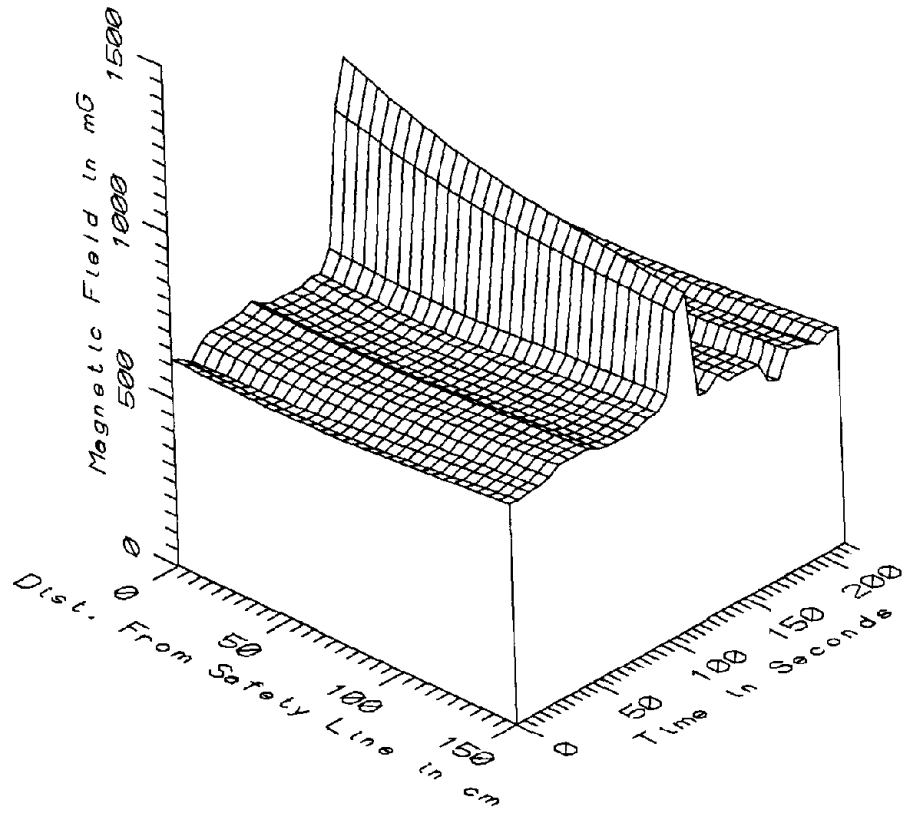

MET018 - 1M ABOVE PLATFORM, SOUTH BOUND SIDE - STATIC

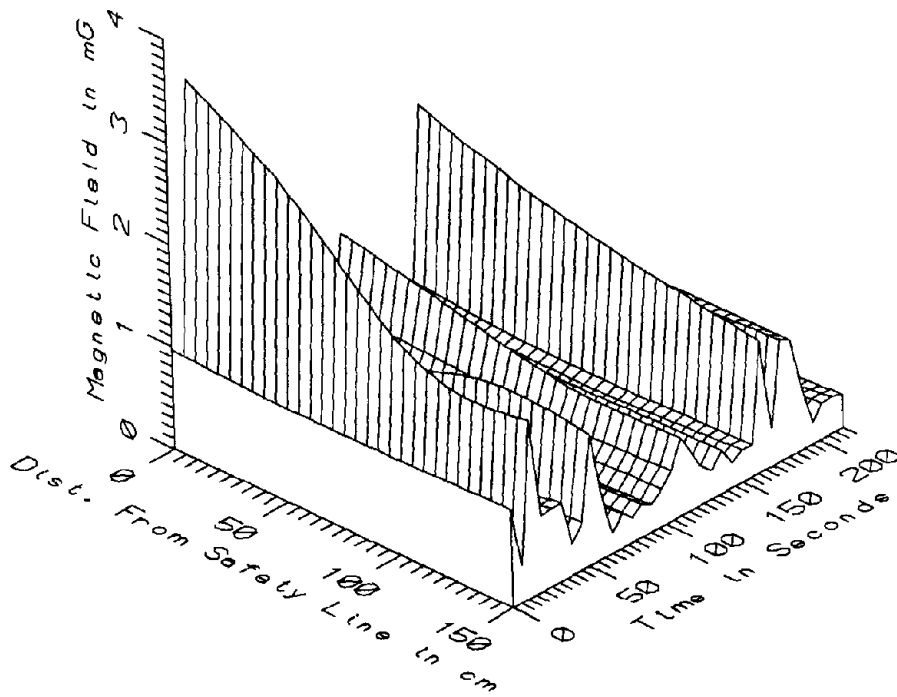

MET018 - 1M ABOVE PLATFORM, SOUTH BOUND SIDE - LOW FREQ. 5-45Hz

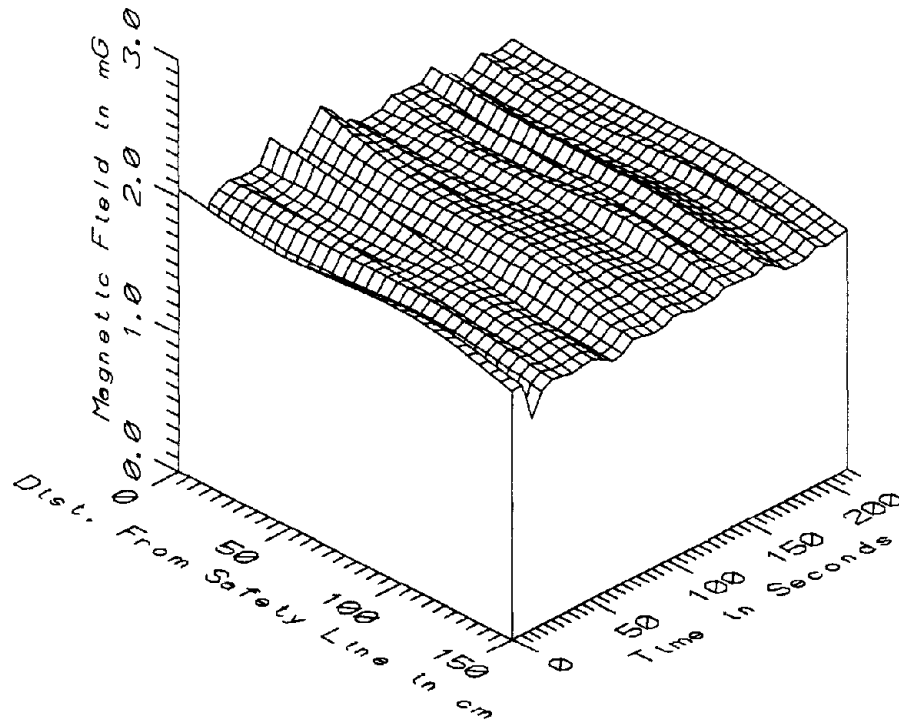

MET018 - 1M ABOVE PLATFORM, SOUTH BOUND SIDE - POWER FREQ, 50-60Hz

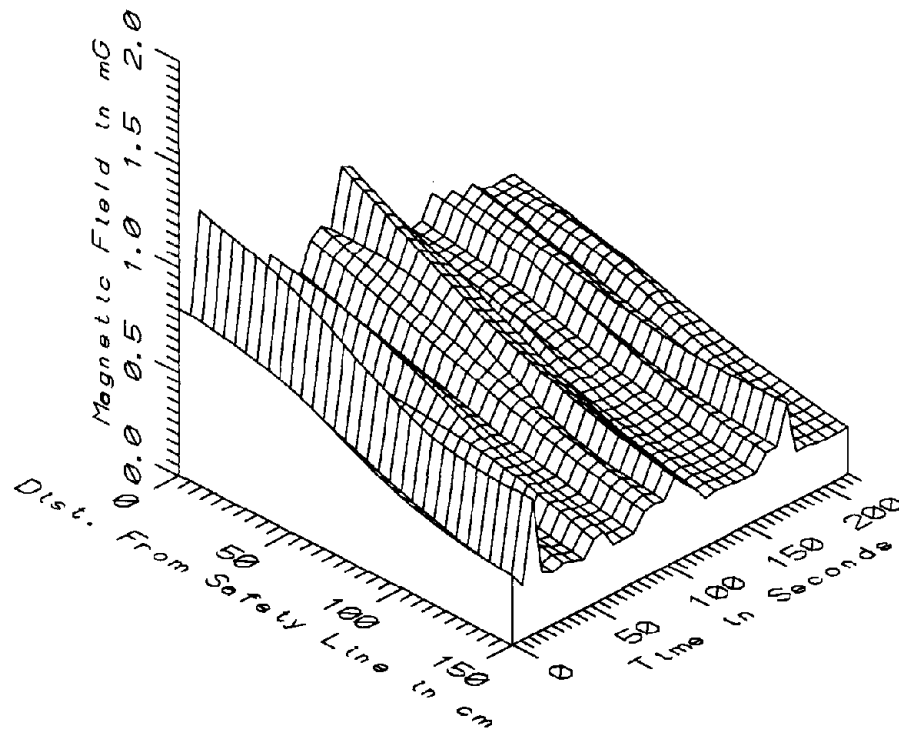

MET018 - 1M ABOVE PLATFORM, SOUTH BOUND SIDE - POWER HARM, 65-300Hz

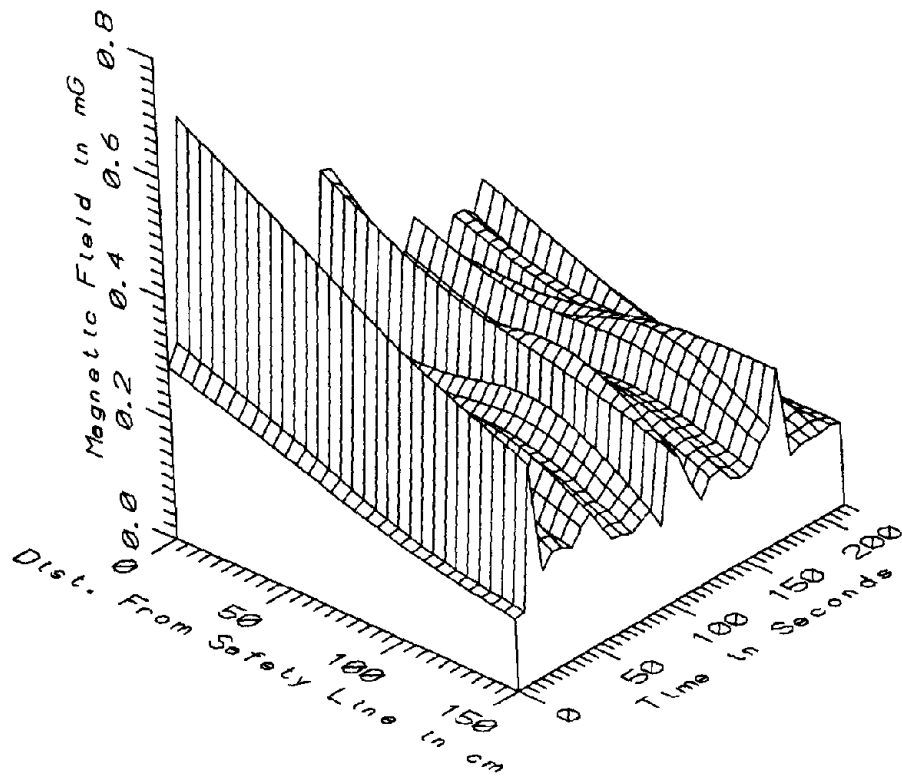

MET018 - 1M ABOVE PLATFORM, SOUTH BOUND SIDE - HIGH FREQ, 305-2560Hz

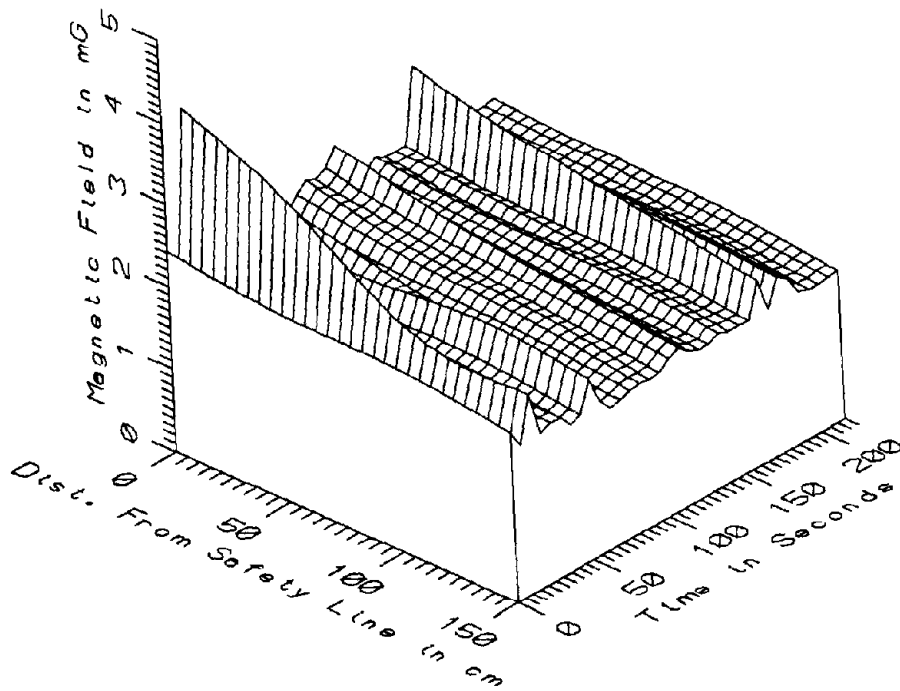

MET018 - 1M ABOVE PLATFORM, SOUTH BOUND SIDE - ALL FREQ, 5-2560Hz

MET018 - GROSVENOR PLATFORM, SOUTH BOUND SIDE		TOTAL OF 34 SAMPLES				
FREQUENCY BAND	DIST FROM LINE (cm)	MINIMUM MAGNETIC FIELD (mG)	MAXIMUM MAGNETIC FIELD (mG)	AVERAGE MAGNETIC FIELD (mG)	STANDARD DEVIATION (mG)	COEFFICIENT OF VARIATION (%)
STATIC	0	532.88	1233.85	650.39	134.74	20.72
	50	529.93	1105.18	639.58	110.17	17.23
	100	548.72	1041.24	656.37	93.67	14.27
	150	587.06	994.44	681.96	78.17	11.46
5-45HZ	0	0.21	3.50	0.71	0.66	92.09
LOW FREQ	50	0.08	2.75	0.56	0.54	95.78
	100	0.19	1.77	0.53	0.41	77.06
	150	0.21	1.69	0.56	0.37	65.94
50-60HZ	0	1.45	2.14	1.92	0.11	5.89
PWR FREQ	50	1.54	1.97	1.86	0.07	3.95
	100	1.55	1.98	1.84	0.07	4.00
	150	1.53	1.80	1.72	0.05	2.89
65-300HZ	0	0.61	1.22	0.73	0.15	20.63
PWR HARM	50	0.49	1.03	0.60	0.11	18.70
	100	0.34	0.72	0.41	0.08	19.70
	150	0.22	0.65	0.29	0.09	30.21
305-2560HZ	0	0.22	0.68	0.30	0.09	28.89
HIGH FREQ	50	0.16	0.56	0.24	0.07	27.90
	100	0.14	0.45	0.23	0.06	26.81
	150	0.12	0.36	0.17	0.05	28.33
5-2560HZ	0	1.96	4.04	2.26	0.38	16.70
ALL FREQ	50	1.90	3.36	2.10	0.27	12.82
	100	1.78	2.50	2.01	0.16	8.05
	150	1.68	2.40	1.87	0.16	8.43

APPENDIX R

DATASET MET019  
GROSVENOR STATION, BOTTOM OF ESCALATOR

Measurement Setup Code:           Staff:     21   Reference:  -  
  Drawing:  A-4

Vehicle Status:                    NA

Measurement Date:                 May 19, 1992

Measurement Time:                 Start:     11:10:10  
  End:       11:10:36

Number of Samples:                6

Programmed Sample Interval:       5 sec

Actual Sample Interval:           5.2 sec

Frequency Spectrum Parameters

<u>Probe Type:</u>	<u>Wideband</u>	<u>Static</u>
Maximum Frequency (Hz)	2560	100
Minimum Frequency (Hz)	5	0
Spectral Bandwidth (Hz)	5	1

Missing Data:  No reference probe

Saturated Data:  None

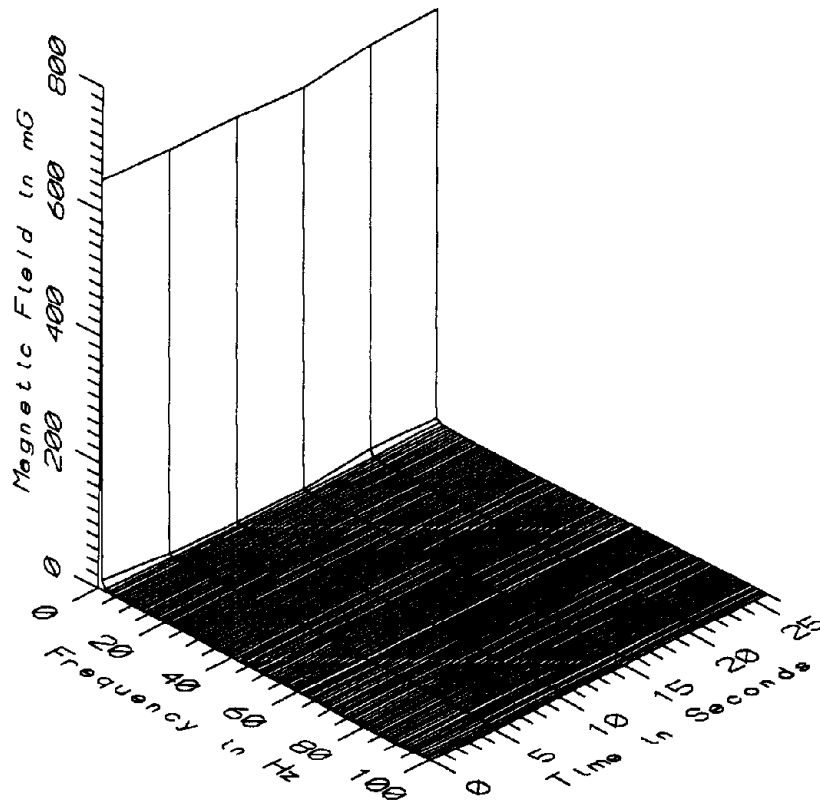

MET019 - 10cm ABOVE FLOOR, BOTTOM OF GROSVENOR STATION ESCALATOR

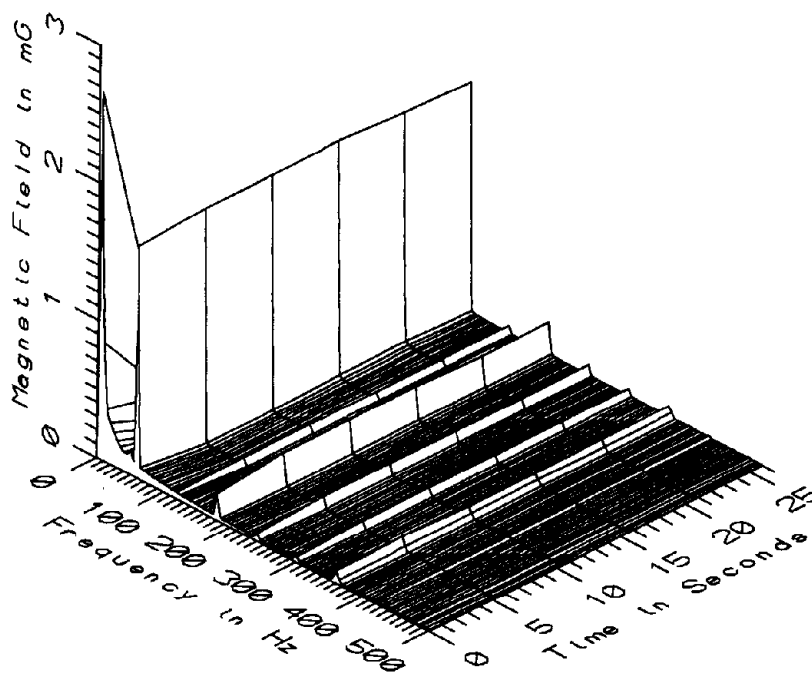

MET019 - 10cm ABOVE FLOOR, BOTTOM OF GROSVENOR STATION ESCALATOR



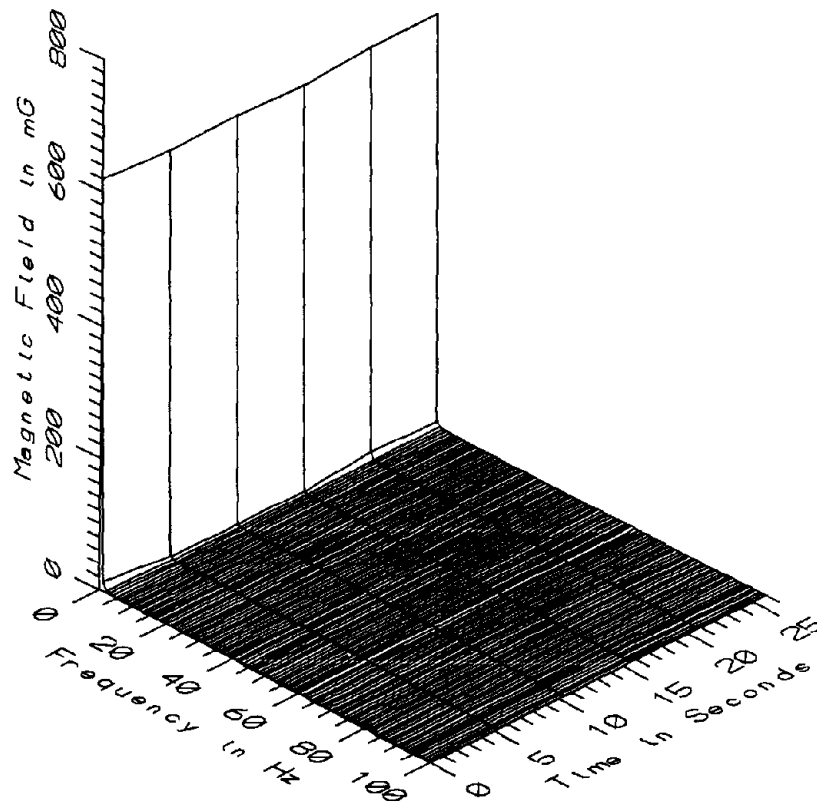

MET019 - 60cm ABOVE FLOOR, BOTTOM OF GROSVENOR STATION ESCALATOR

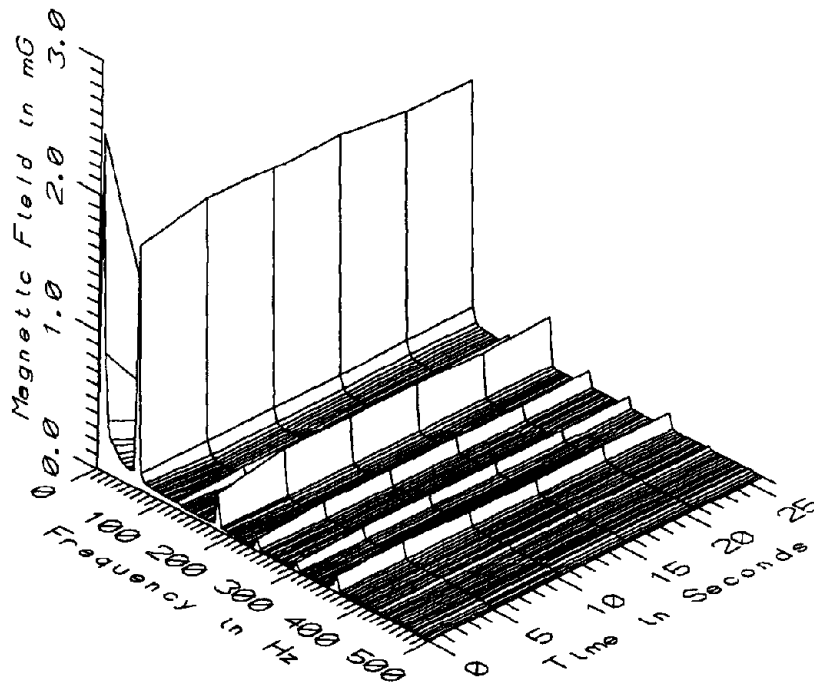

MET019 - 60cm ABOVE FLOOR, BOTTOM OF GROSVENOR STATION ESCALATOR

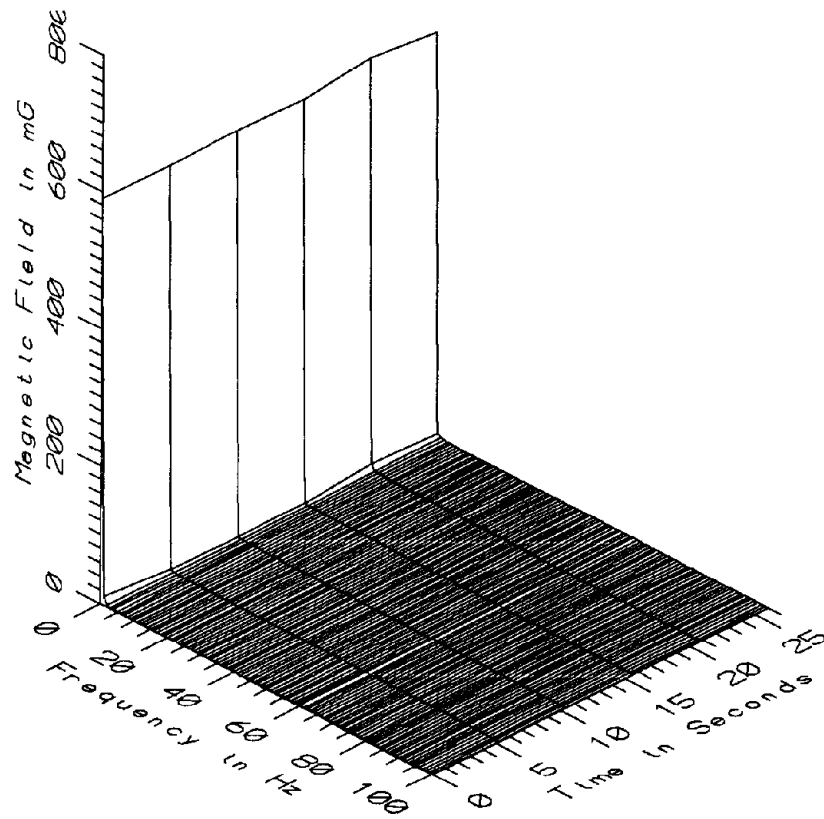

MET019 - 110cm ABOVE FLOOR, BOTTOM OF GROSVENOR STATION ESCALATOR

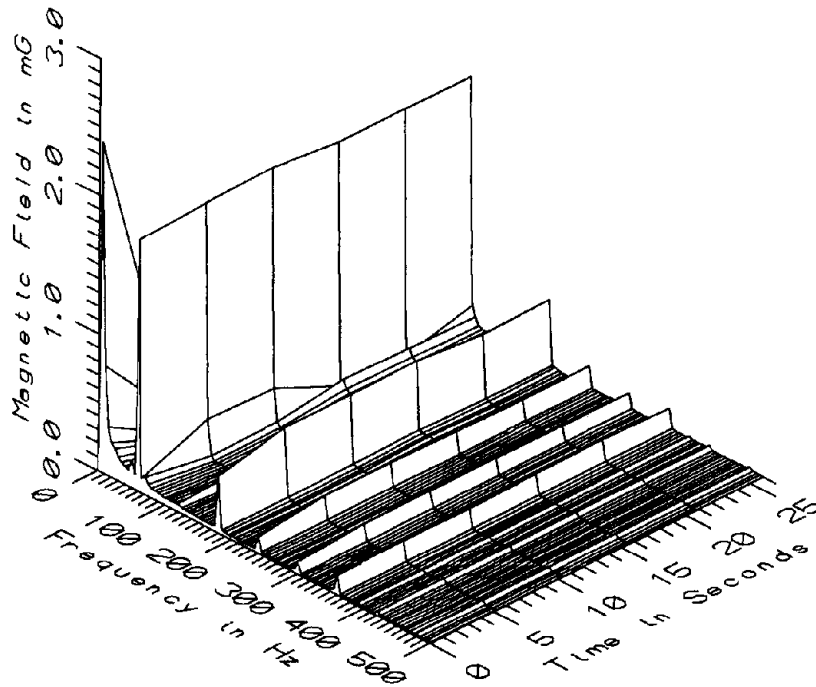

MET019 - 110cm ABOVE FLOOR, BOTTOM OF GROSVENOR STATION ESCALATOR

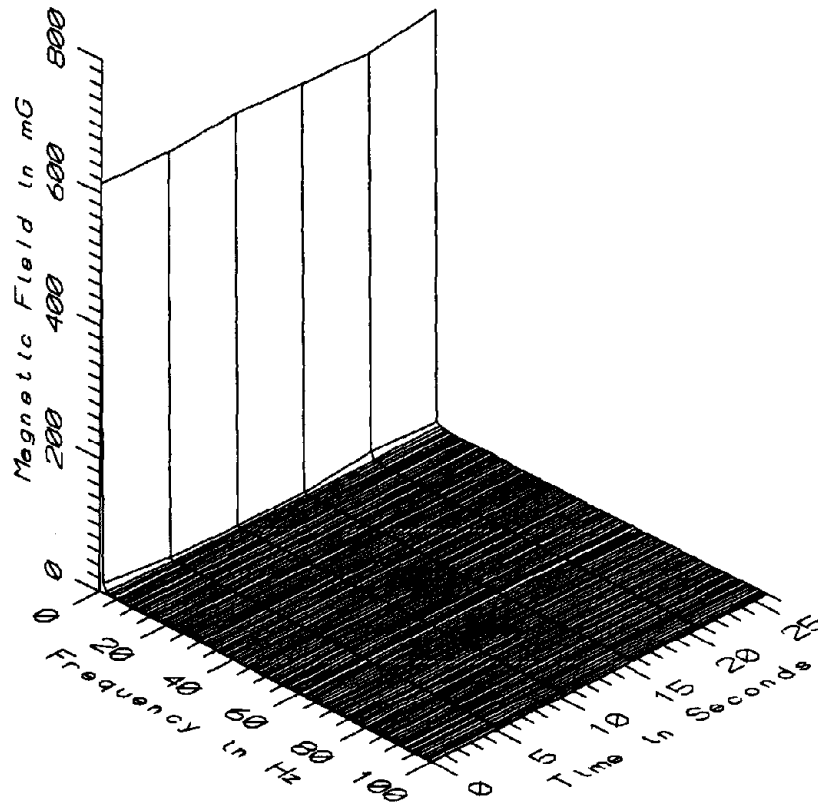

MET019 - 160cm ABOVE FLOOR, BOTTOM OF GROSVENOR STATION ESCALATOR

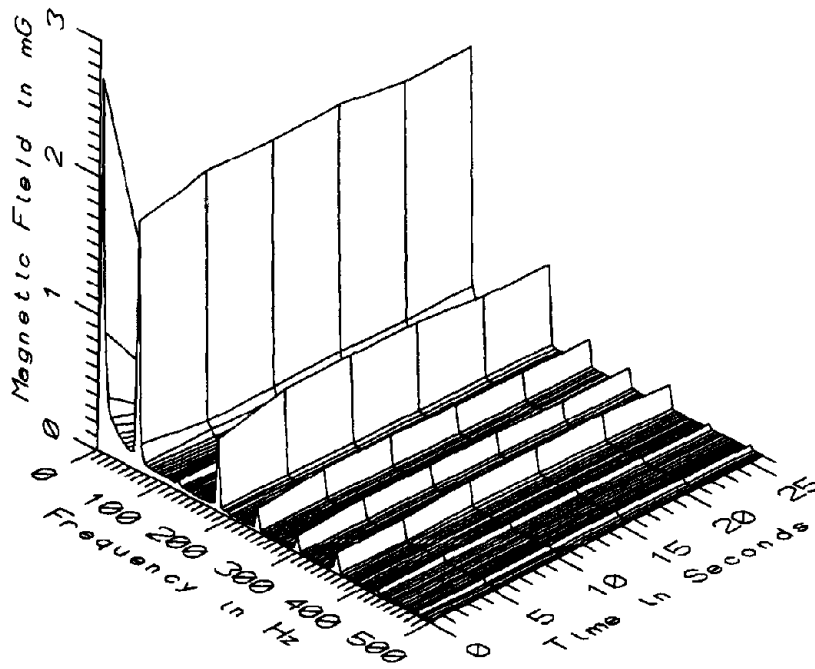

MET019 - 160cm ABOVE FLOOR, BOTTOM OF GROSVENOR STATION ESCALATOR

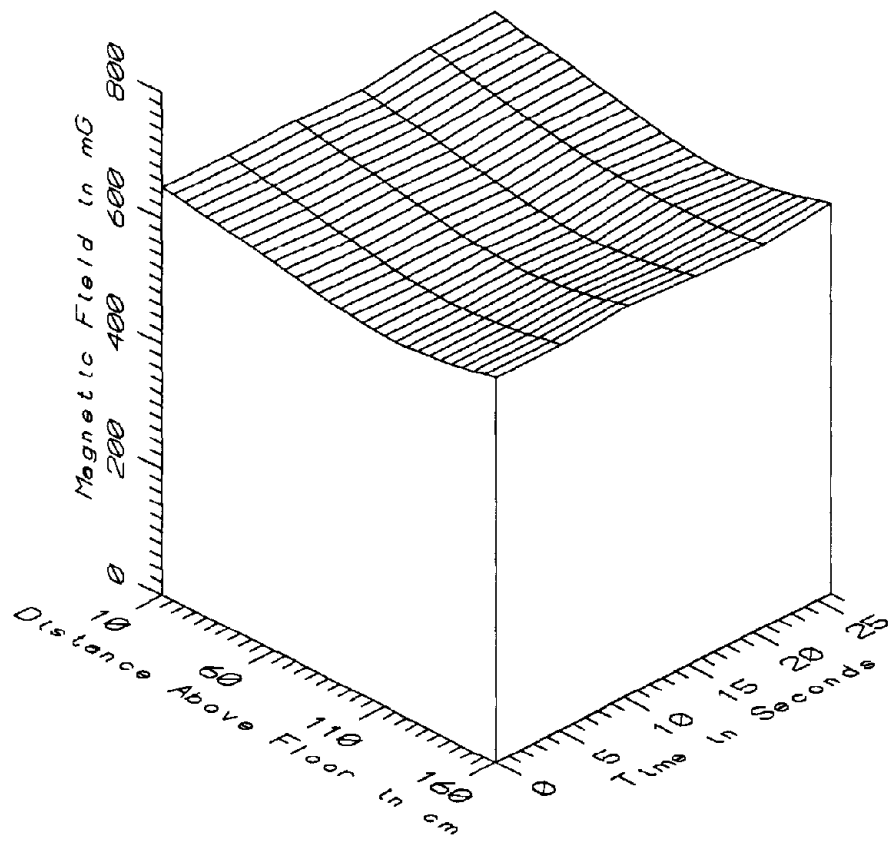

MET019 - BOTTOM OF GROSVENOR STATION ESCALATOR - STATIC

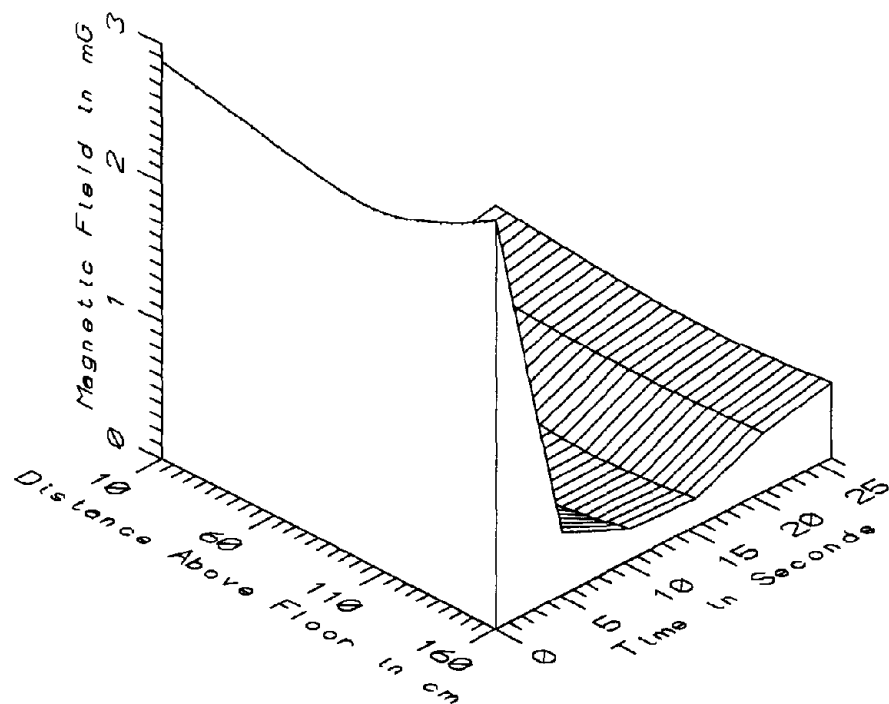

MET019 - BOTTOM OF GROSVENOR STATION ESCALATOR - LOW FREQ, 5-45Hz

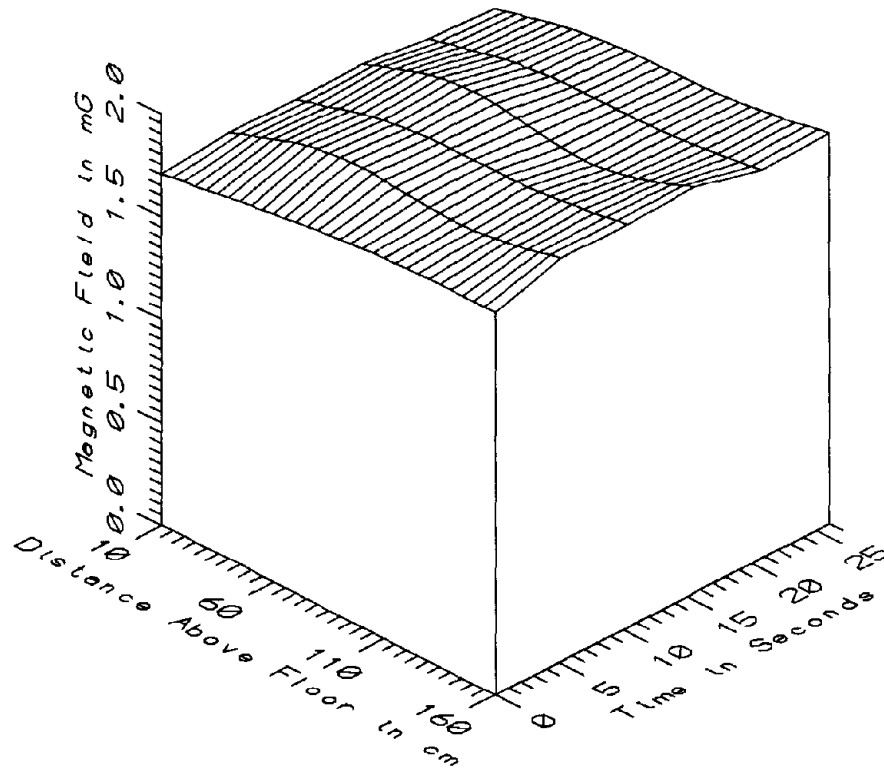

MET019 - BOTTOM OF GROSVENOR STATION ESCALATOR - POWER FREQ, 50-60Hz

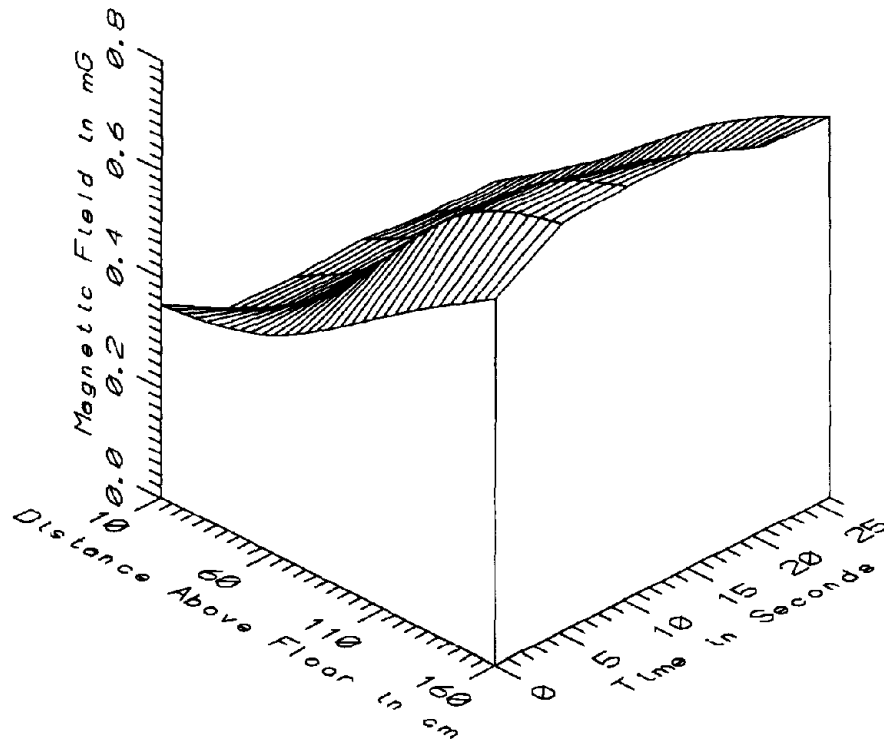

MET019 - BOTTOM OF GROSVENOR STATION ESCALATOR - POWER HARM, 65-300Hz

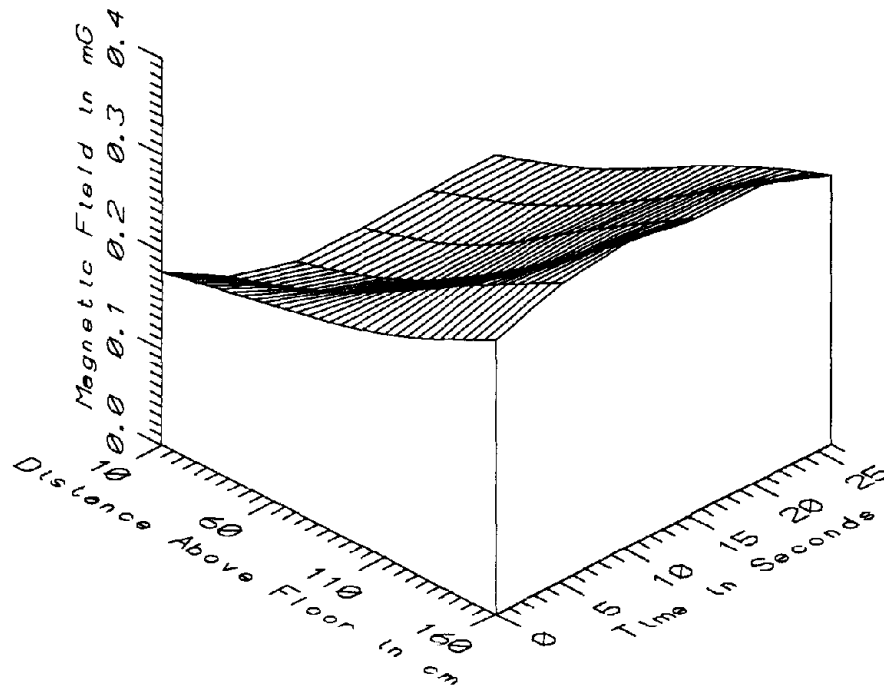

MET019 - BOTTOM OF GROSVENOR STATION ESCALATOR - HIGH FREQ, 305-2560Hz

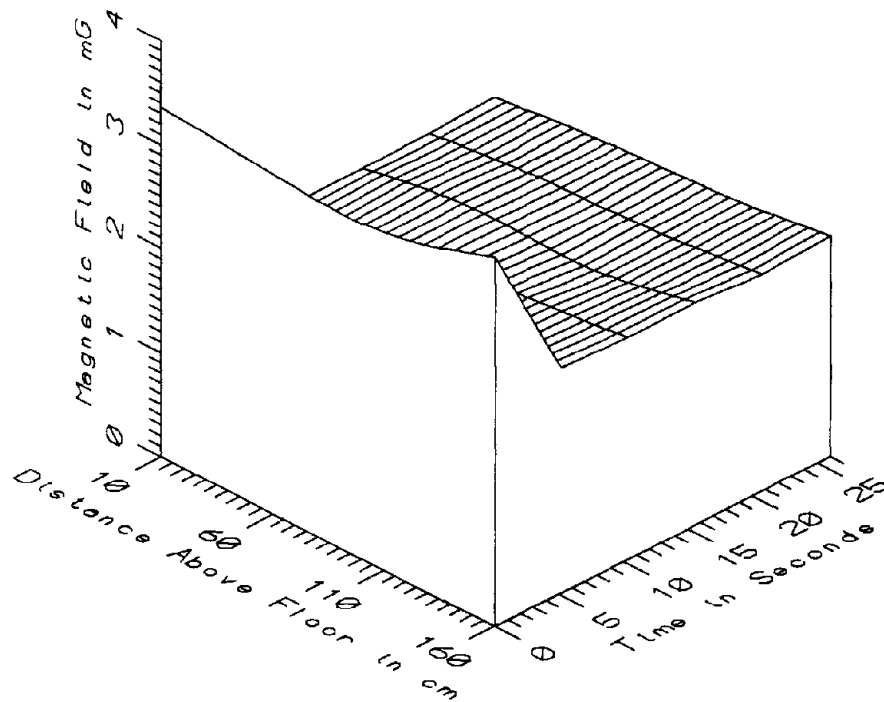

MET019 - BOTTOM OF GROSVENOR STATION ESCALATOR - ALL FREQ, 5-2560Hz

MET019 - BOTTOM OF ESCALATOR, GROSVENOR STATION		TOTAL OF 6 SAMPLES				
FREQUENCY BAND	HEIGHT ABOVE FLOOR (cm)	MINIMUM MAGNETIC FIELD (mG)	MAXIMUM MAGNETIC FIELD (mG)	AVERAGE MAGNETIC FIELD (mG)	STANDARD DEVIATION (mG)	COEFFICIENT OF VARIATION (%)
STATIC	10	641.79	658.72	649.99	6.42	0.99
	60	611.36	621.15	617.05	3.95	0.64
	110	588.16	601.82	592.08	4.99	0.84
	160	608.97	622.39	615.28	5.07	0.82
5-45Hz LOW FREQ	10	0.22	2.87	0.83	1.01	122.07
	60	0.20	2.69	0.74	0.96	129.68
	110	0.12	2.60	0.69	0.95	136.91
50-60Hz PWR FREQ	160	0.20	2.94	0.80	1.06	132.53
	10	1.69	1.75	1.72	0.02	1.37
	60	1.79	1.89	1.84	0.05	2.53
65-300Hz PWR HARM	110	1.82	1.88	1.84	0.02	1.34
	160	1.85	1.96	1.91	0.05	2.45
	10	0.27	0.35	0.29	0.03	10.47
305-2560Hz HIGH FREQ	60	0.40	0.42	0.41	0.01	2.33
	110	0.53	0.65	0.60	0.05	8.09
	160	0.67	0.76	0.72	0.04	5.00
	10	0.12	0.18	0.13	0.02	17.39
5-2560Hz ALL FREQ	60	0.16	0.20	0.17	0.02	9.64
	110	0.23	0.25	0.23	0.01	2.73
	160	0.28	0.32	0.30	0.01	4.86
	10	1.79	3.36	2.07	0.64	30.74
5-2560Hz ALL FREQ	60	1.92	3.26	2.16	0.54	24.85
	110	1.94	3.24	2.19	0.51	23.33
	160	2.08	3.55	2.36	0.58	24.75





APPENDIX 8

DATASET MET021  
GROSVENOR STATION, ON THE ESCALATOR

Measurement Setup Code:        Staff:    22,23    Reference: -  
   Drawing:  A-4

Vehicle Status:                NA

Measurement Date:              May 19, 1992

Measurement Time:              Start:    11:15:52  
   End:      11:17:20

Number of Samples:             13

Programmed Sample Interval:    5 sec

Actual Sample Interval:        7.3 sec

Frequency Spectrum Parameters

<u>Probe Type:</u>	<u>Wideband</u>	<u>Static</u>
Maximum Frequency (Hz)	2560	100
Minimum Frequency (Hz)	5	0
Spectral Bandwidth (Hz)	5	1

Missing Data: No reference probe

Saturated Data: None

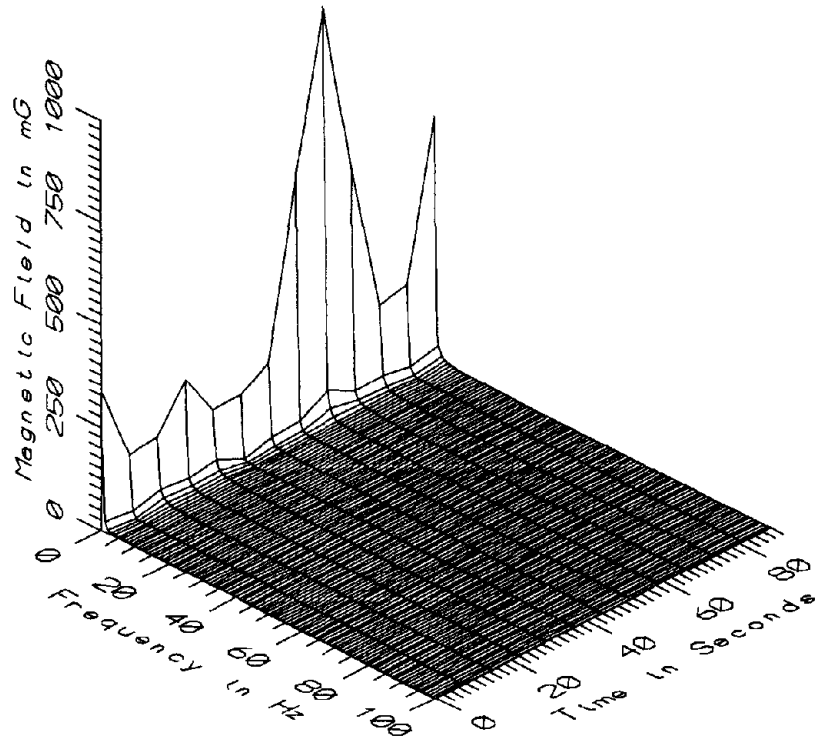

MET021 - 10cm ABOVE STEP, ESCALATOR AT GROSVENOR STATION

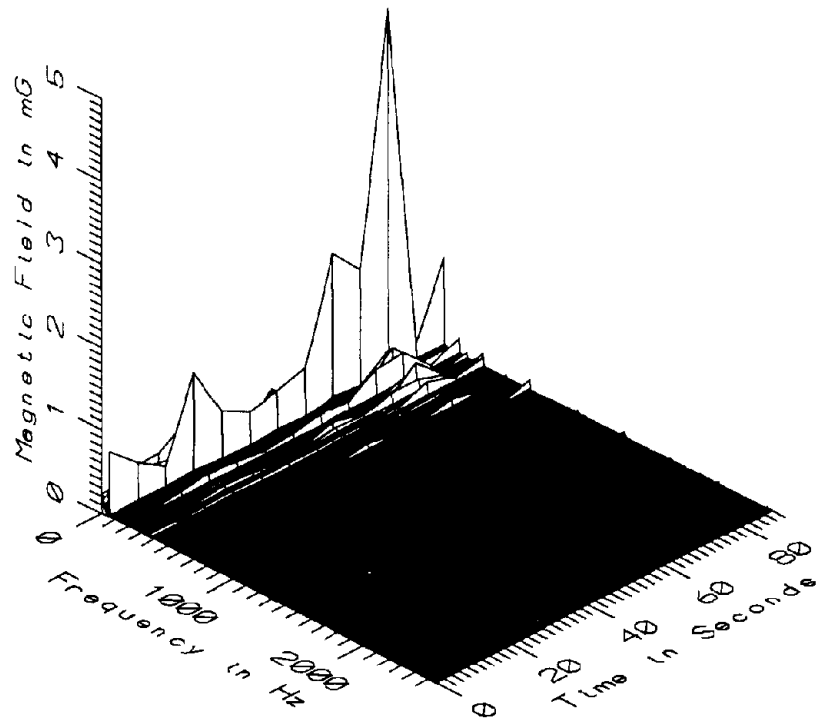

MET021 - 10cm ABOVE STEP, ESCALATOR AT GROSVENOR STATION

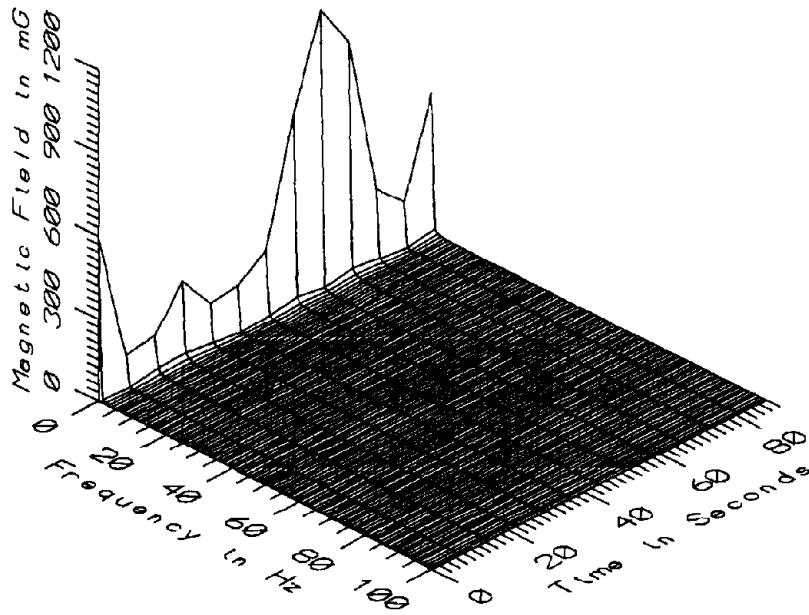

MET021 - 60cm ABOVE STEP, ESCALATOR AT GROSVENOR STATION

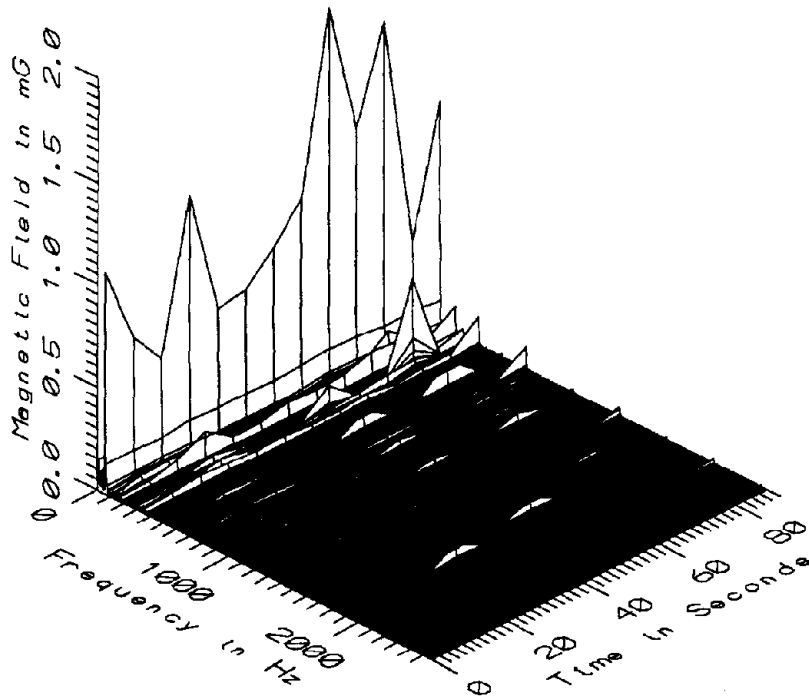

MET021 - 60cm ABOVE STEP, ESCALATOR AT GROSVENOR STATION

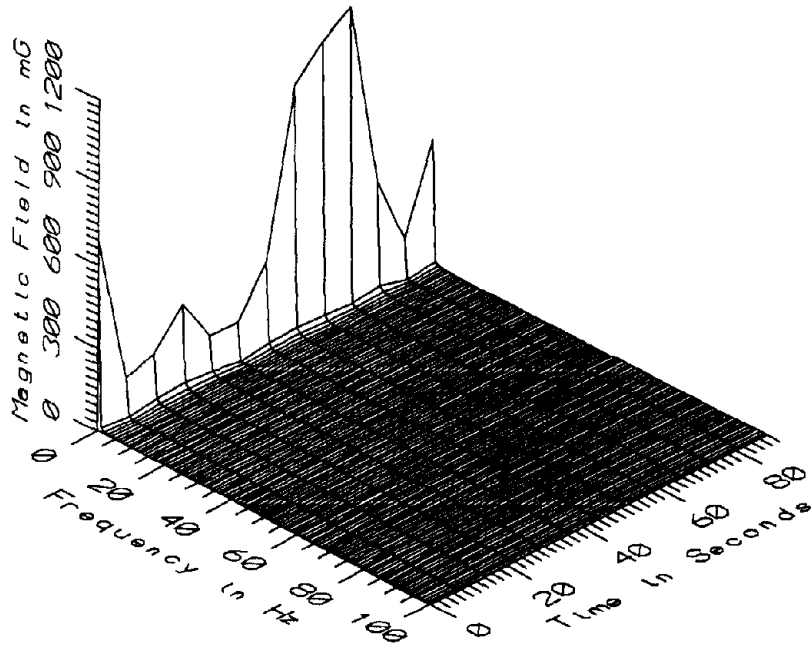

MET021 - 110cm ABOVE STEP, ESCALATOR AT GROSVENOR STATION

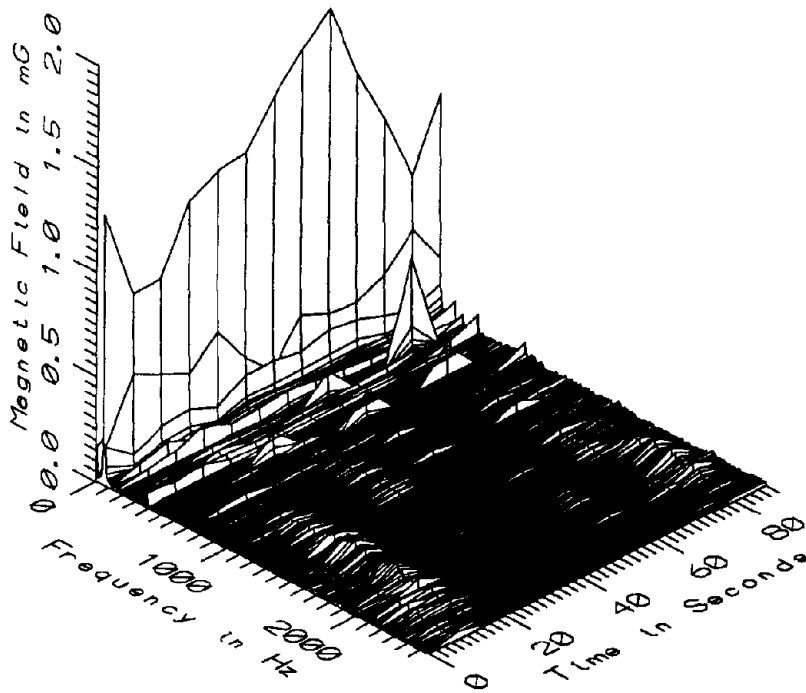

MET021 - 110cm ABOVE STEP, ESCALATOR AT GROSVENOR STATION

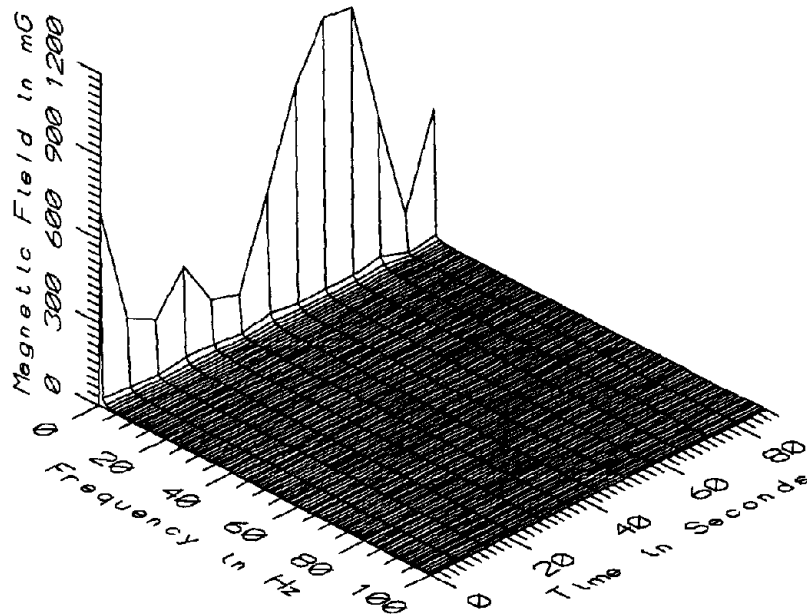

MET021 - 160cm ABOVE STEP, ESCALATOR AT GROSVENOR STATION

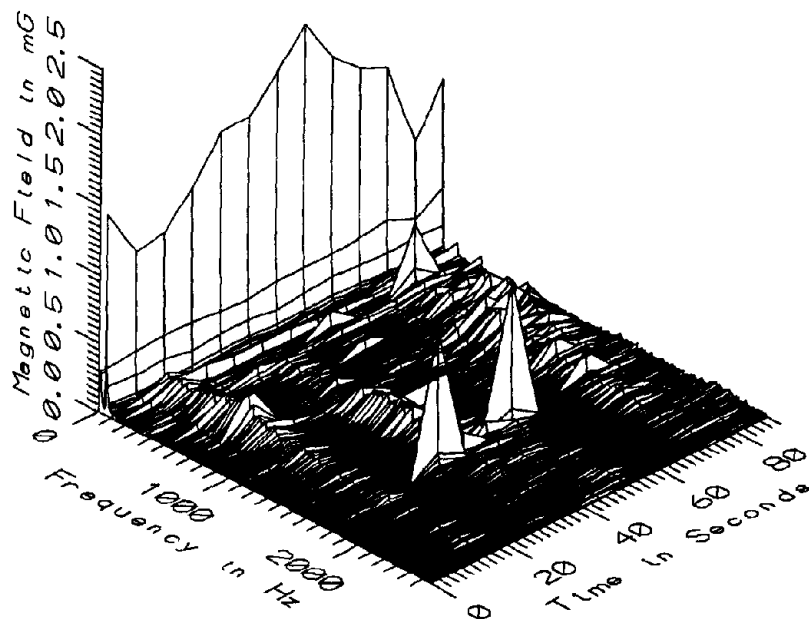

MET021 - 160cm ABOVE STEP, ESCALATOR AT GROSVENOR STATION

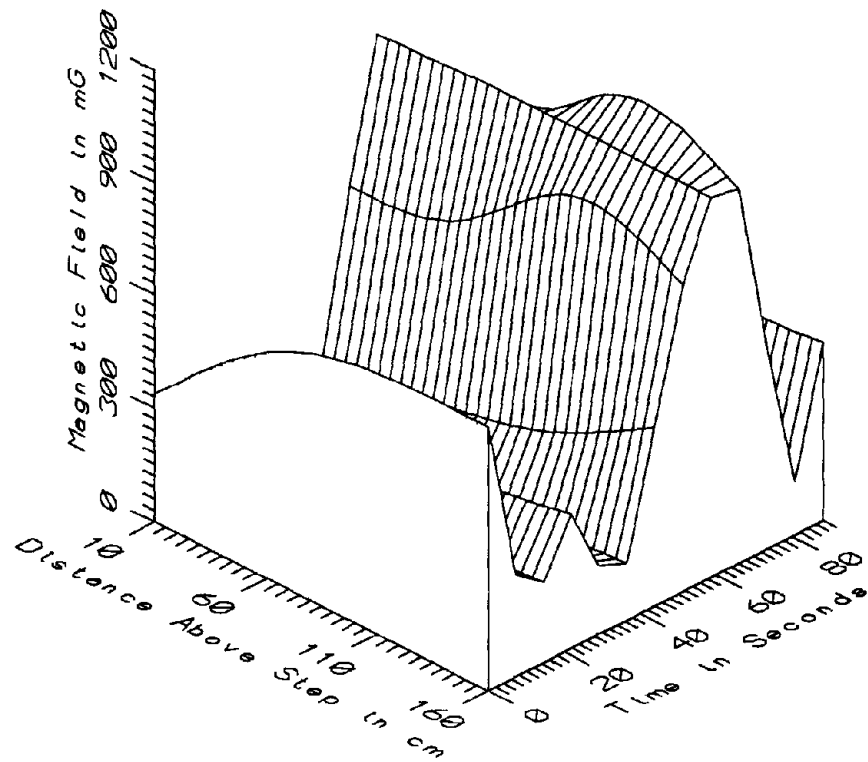

MET021 - ESCALATOR AT GROSVENOR STATION - STATIC

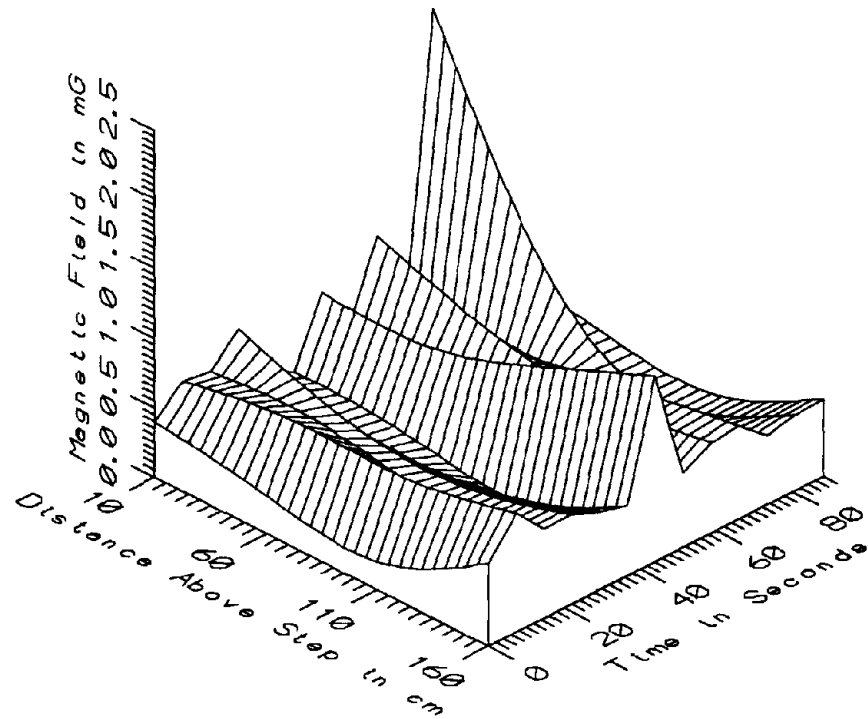

MET021 - ESCALATOR AT GROSVENOR STATION - LOW FREQ, 5-45Hz

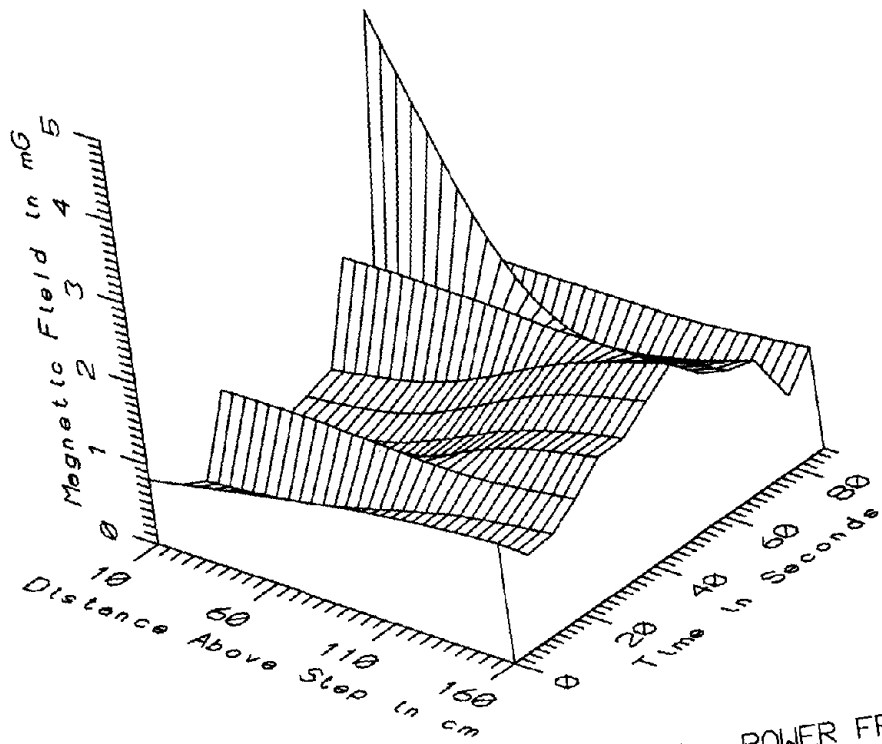

MET021 - ESCALATOR AT GROSVENOR STATION - POWER FREQ, 50-60Hz

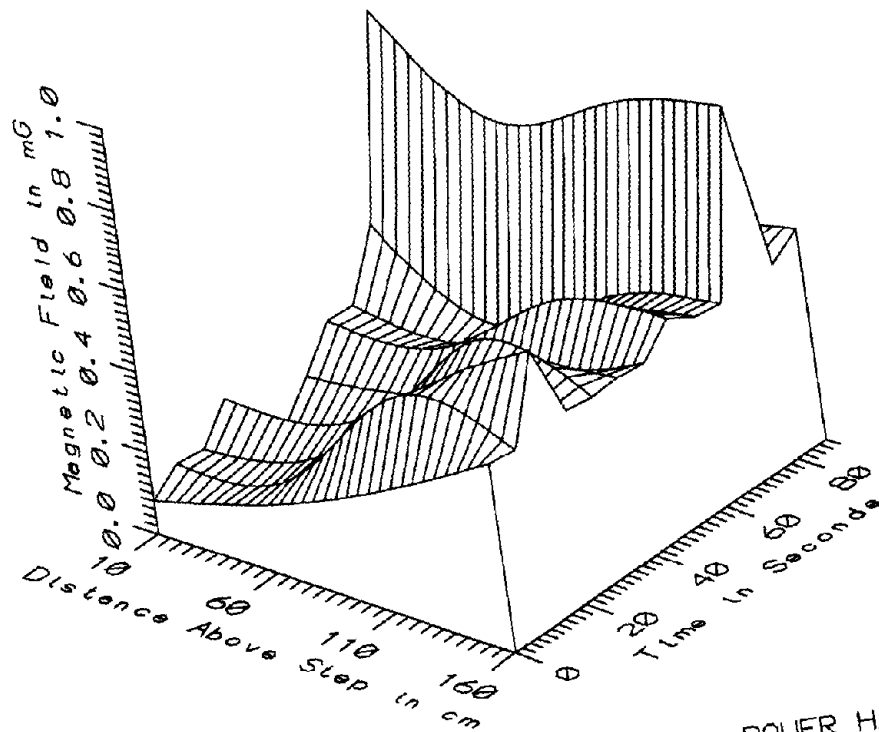

MET021 - ESCALATOR AT GROSVENOR STATION - POWER HARM, 65-300Hz

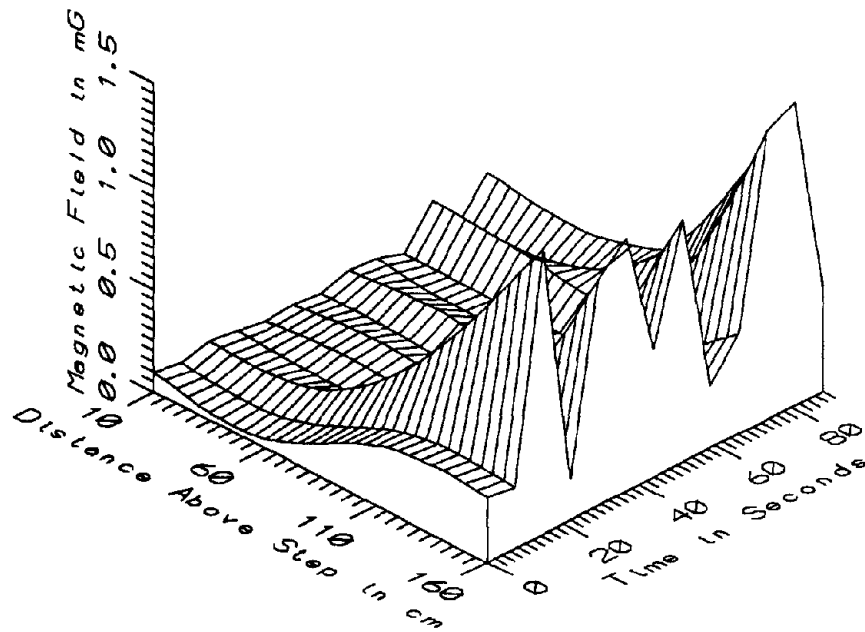

MET021 - ESCALATOR AT GROSVENOR STATION - HIGH FREQ, 305-2560Hz

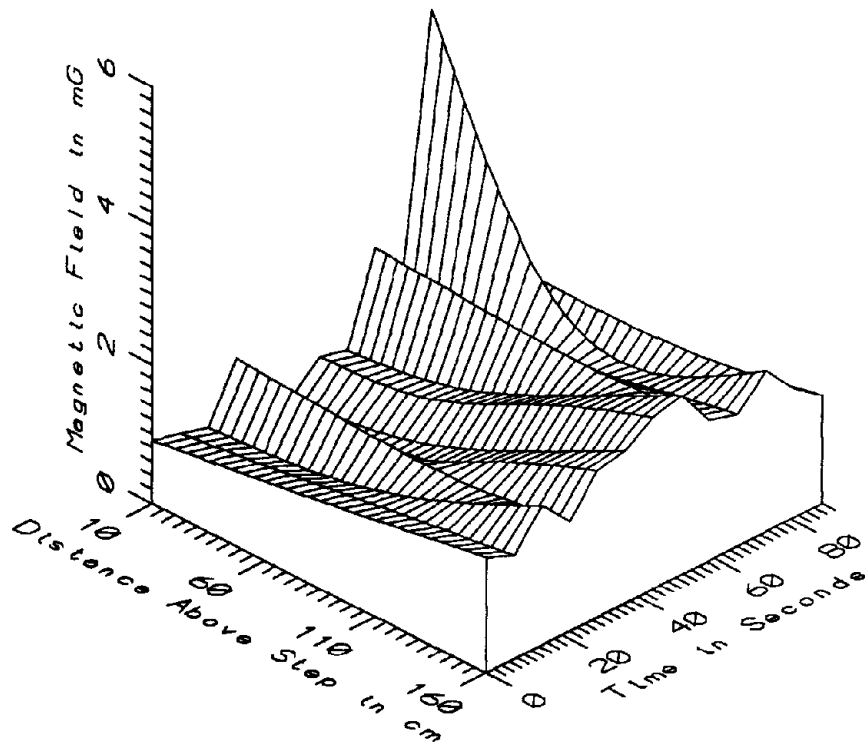

MET021 - ESCALATOR AT GROSVENOR STATION - ALL FREQ, 5-2560Hz



MET021 - ON ESCALATOR, GROSVENOR STATION				TOTAL OF 13 SAMPLES			
FREQUENCY BAND	HEIGHT ABOVE STEP (cm)	MINIMUM MAGNETIC FIELD (mG)	MAXIMUM MAGNETIC FIELD (mG)	AVERAGE MAGNETIC FIELD (mG)	STANDARD DEVIATION (mG)	COEFFICIENT OF VARIATION (%)	
STATIC	10	148.19	996.22	356.64	262.65	73.65	
	60	117.78	1009.35	398.03	298.68	75.04	
	110	141.30	1089.70	455.26	350.49	76.99	
	160	142.83	1006.46	484.23	308.10	63.63	
5-45Hz	10	0.25	2.36	0.64	0.55	86.54	
LOW FREQ	60	0.21	0.90	0.46	0.23	49.64	
	110	0.14	1.00	0.41	0.25	59.09	
	160	0.50	1.34	0.66	0.23	33.90	
50-60Hz	10	0.31	4.43	1.09	1.10	101.08	
PWR FREQ	60	0.48	1.82	0.98	0.41	41.97	
	110	0.80	1.77	1.25	0.29	23.26	
	160	0.88	2.15	1.51	0.35	23.54	
65-300Hz	10	0.05	0.85	0.21	0.21	97.84	
PWR HARM	60	0.16	0.68	0.23	0.14	58.77	
	110	0.30	0.82	0.45	0.13	29.08	
	160	0.45	0.91	0.52	0.13	25.00	
305-2560Hz	10	0.06	0.26	0.11	0.06	57.58	
HIGH FREQ	60	0.05	0.21	0.11	0.06	52.16	
	110	0.11	0.60	0.27	0.16	56.93	
	160	0.20	1.47	0.80	0.49	60.90	
5-2560Hz	10	0.51	5.09	1.32	1.22	92.45	
ALL FREQ	60	0.59	1.98	1.14	0.43	37.69	
	110	1.11	1.91	1.46	0.24	16.47	
	160	1.50	2.56	1.98	0.34	17.38	



APPENDIX T

DATASET MET022  
GROSVENOR STATION, NORTH BOUND SIDE OF PLATFORM

Measurement Setup Code:        Staff:    24    Reference: 25  
   Drawing: A-4

Vehicle Status:                    NA

Measurement Date:                May 19, 1992

Measurement Time:                Start:    11:19:59  
   End:      11:20:55

Number of Samples:                11

Programmed Sample Interval:    5 sec

Actual Sample Interval:         5.6 sec

Frequency Spectrum Parameters

<u>Probe Type:</u>	<u>Wideband</u>	<u>Static</u>
Maximum Frequency (Hz)	2560	100
Minimum Frequency (Hz)	5	0
Spectral Bandwidth (Hz)	5	1

Missing Data: Wideband data from the reference probe

Saturated Data: None

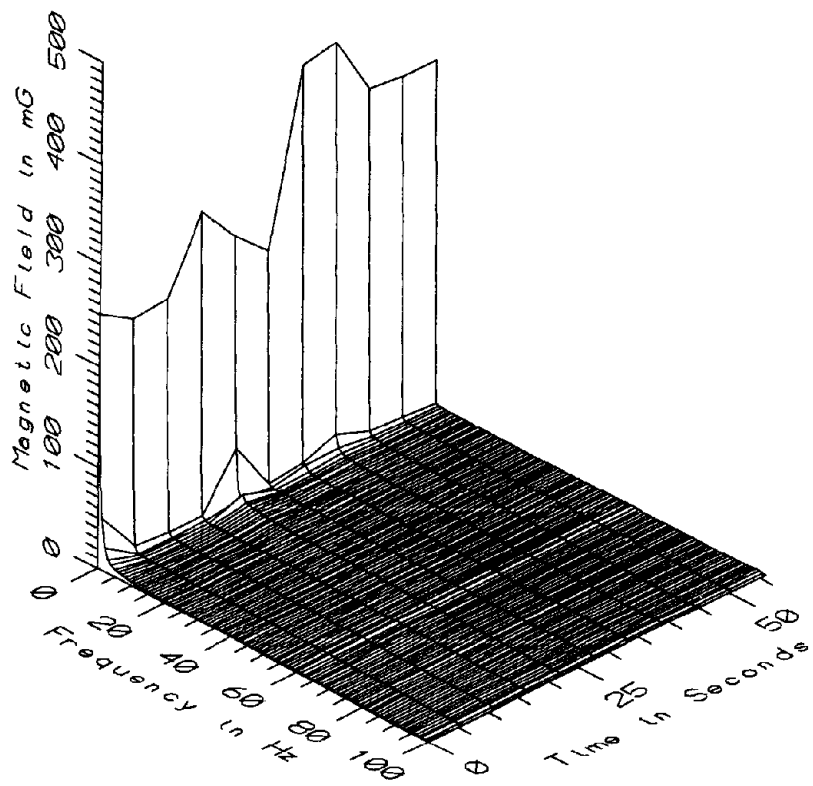

MET022 - 10cm ABOVE FLOOR, CENTER OF PLATFORM AT SAFETY LINE

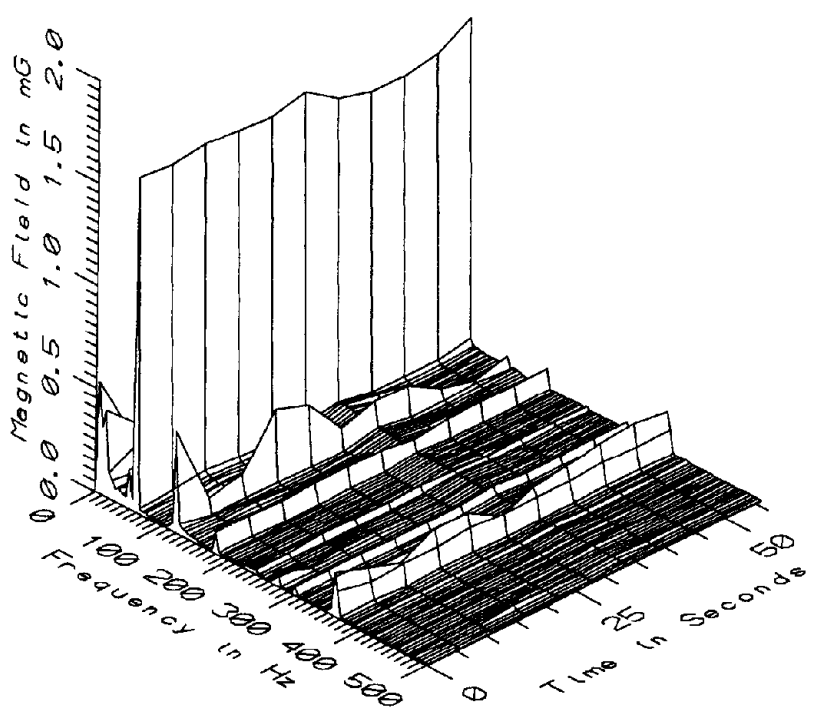

MET022 - 10cm ABOVE FLOOR, CENTER OF PLATFORM AT SAFETY LINE

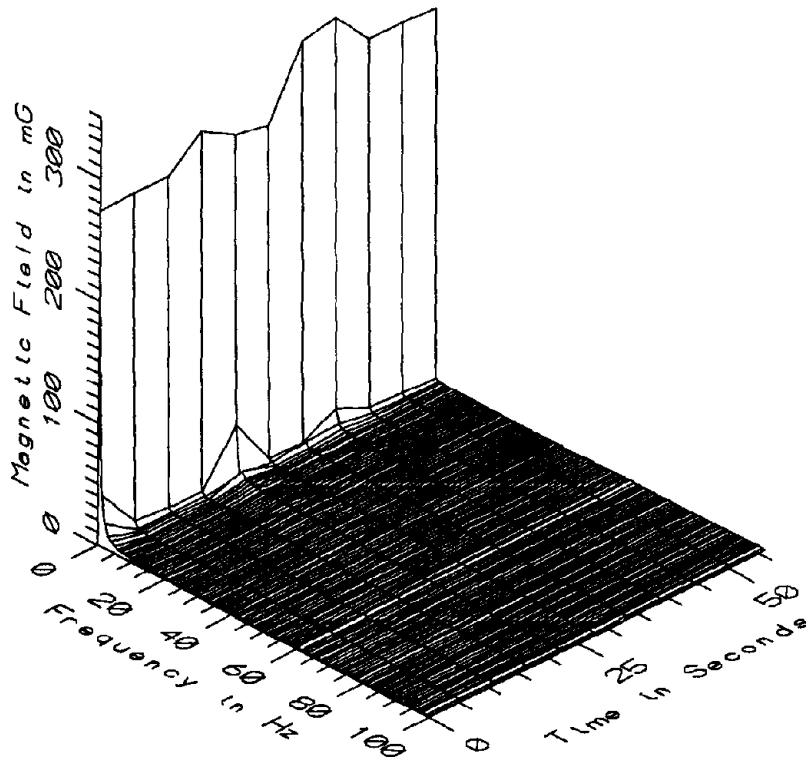

MET022 - 60cm ABOVE FLOOR, CENTER OF PLATFORM AT SAFETY LINE

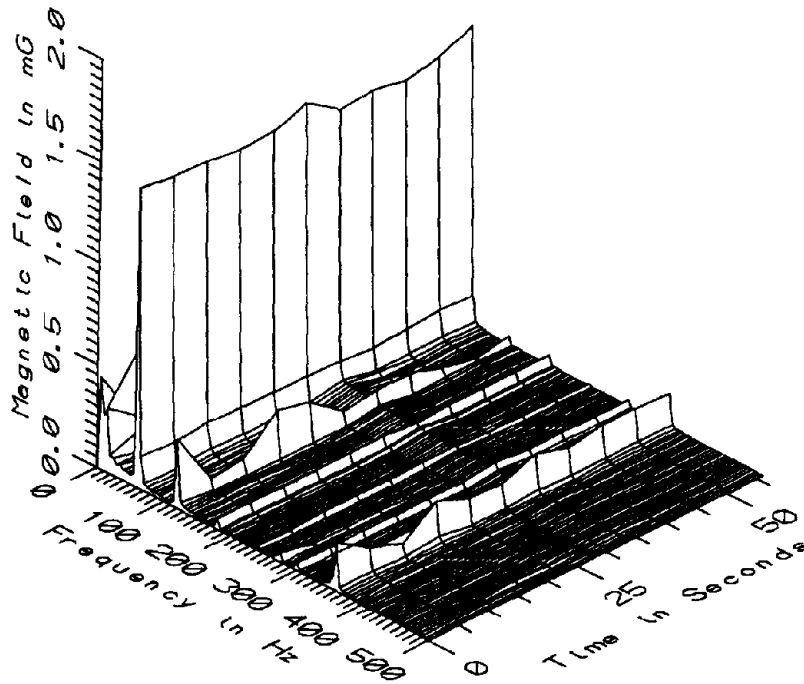

MET022 - 60cm ABOVE FLOOR, CENTER OF PLATFORM AT SAFETY LINE

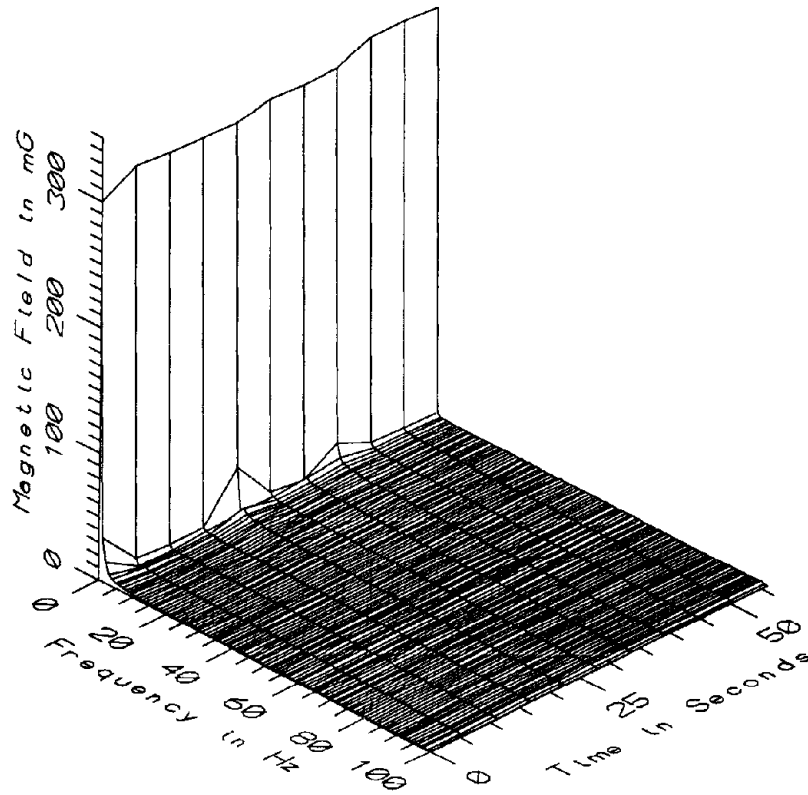

MET022 - 110cm ABOVE FLOOR, CENTER OF PLATFORM AT SAFETY LINE

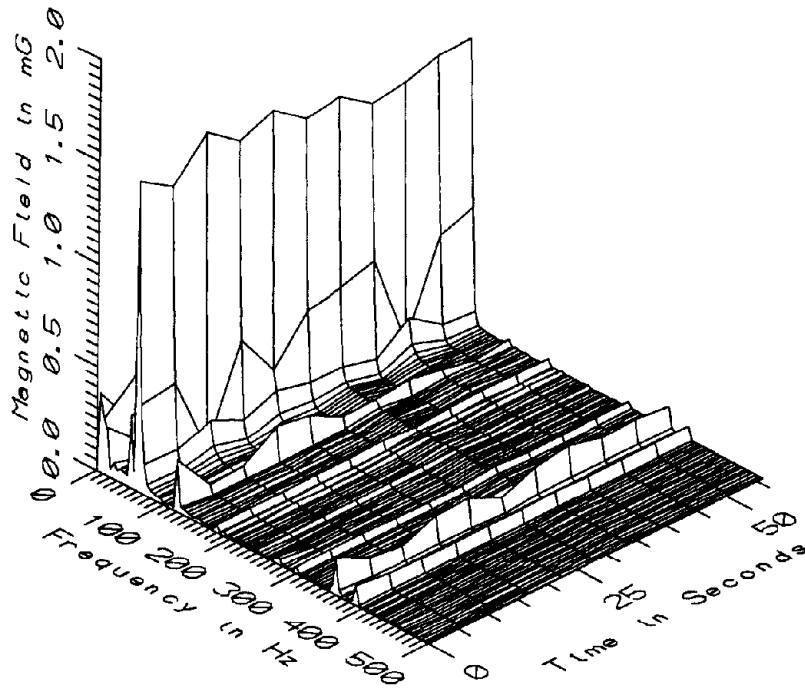

MET022 - 110cm ABOVE FLOOR, CENTER OF PLATFORM AT SAFETY LINE

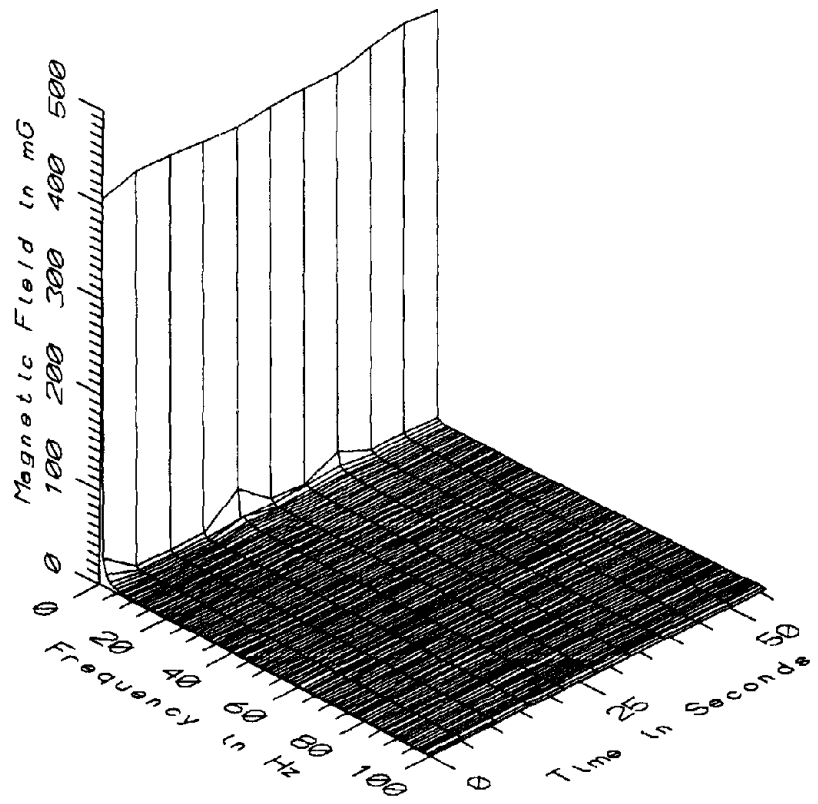

MET022 - 160cm ABOVE FLOOR, CENTER OF PLATFORM AT SAFETY LINE

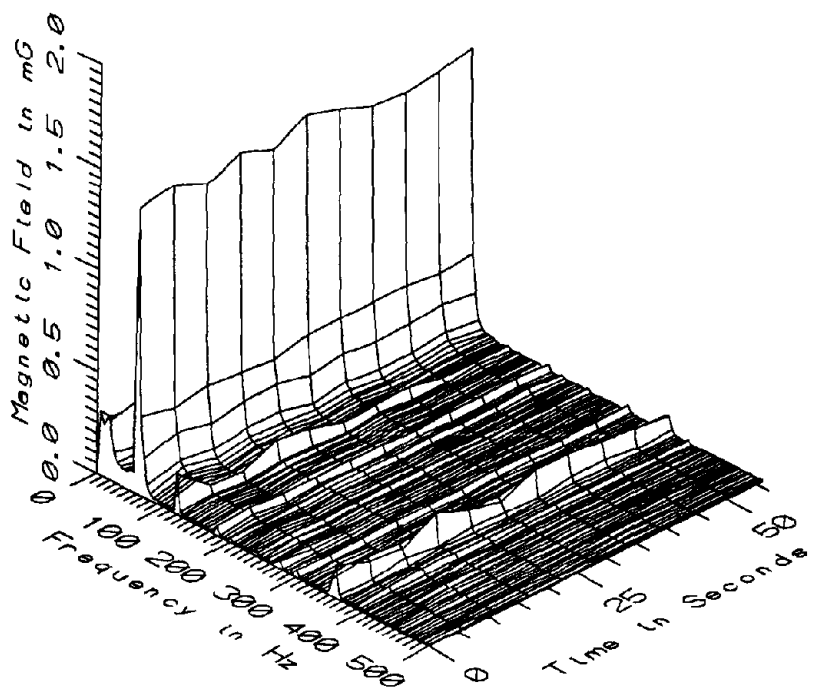

MET022 - 160cm ABOVE FLOOR, CENTER OF PLATFORM AT SAFETY LINE

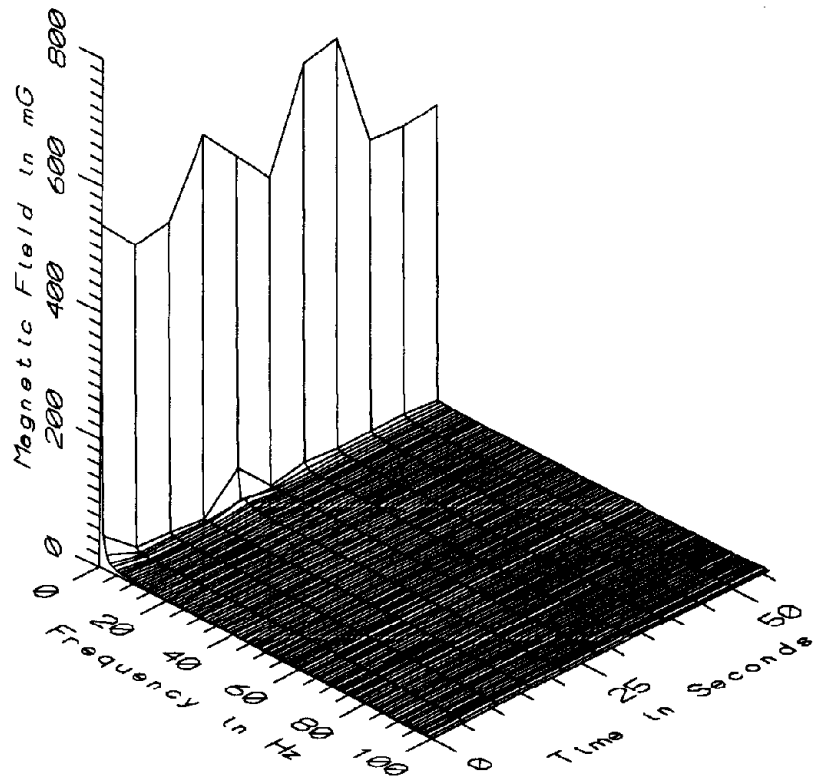

MET022 - REFERENCE PROBE - AT SAFETY LINE, NORTH BOUND SIDE



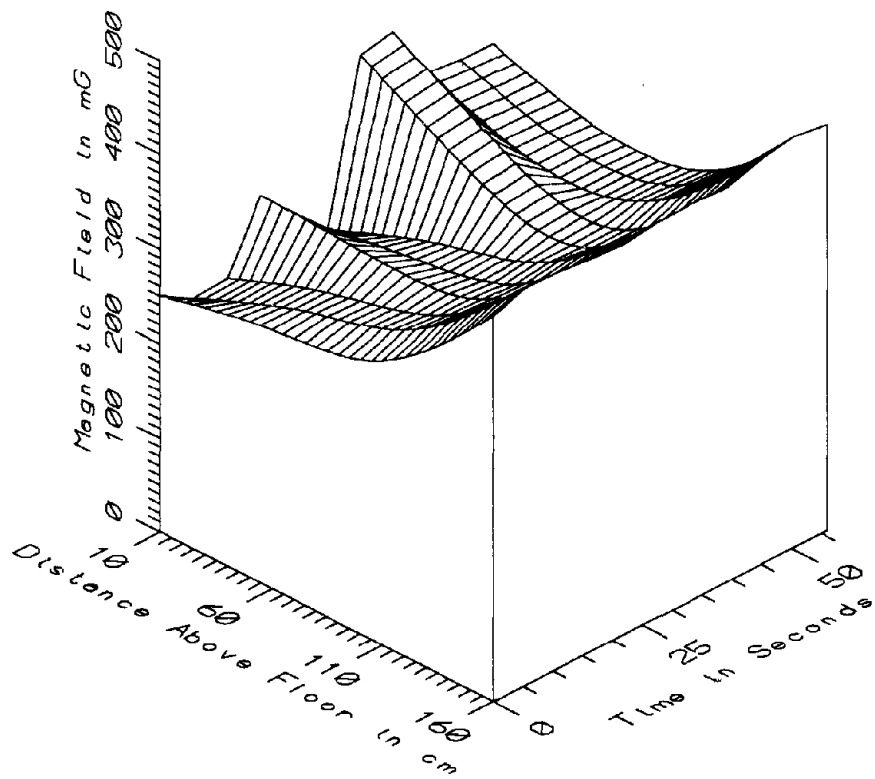

MET022 - CENTER OF PLATFORM AT SAFETY LINE - STATIC

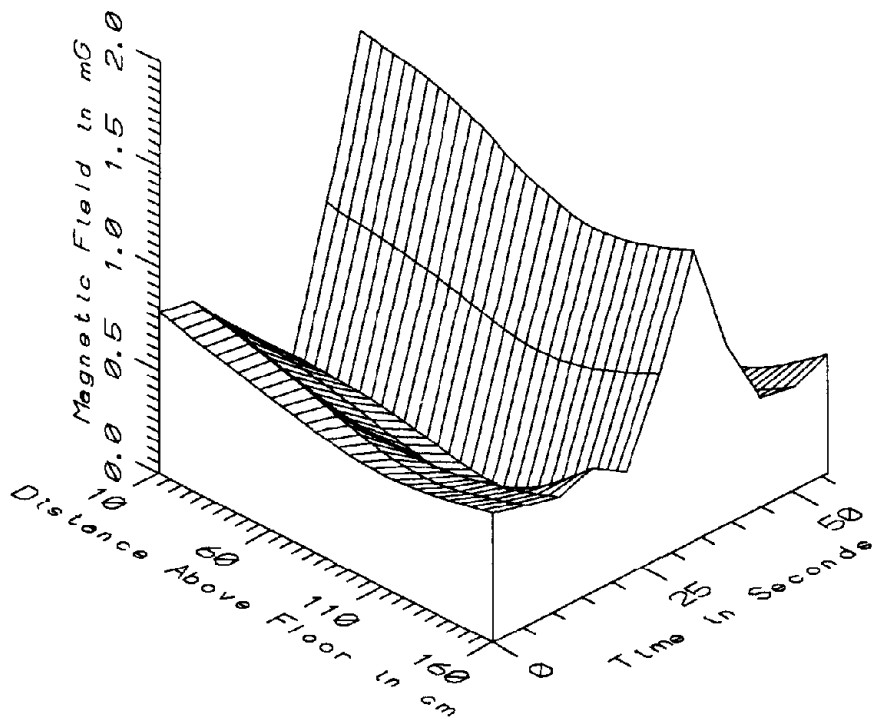

MET022 - CENTER OF PLATFORM AT SAFETY LINE - LOW FREQ. 5-45Hz

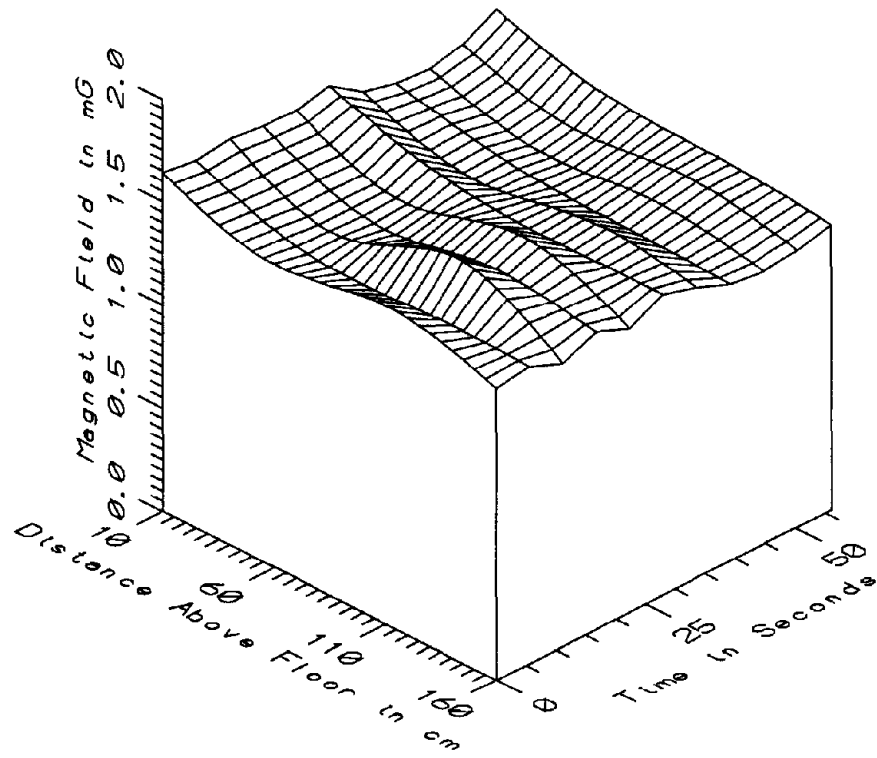

MET022 - CENTER OF PLATFORM AT SAFETY LINE - POWER FREQ, 50-60Hz

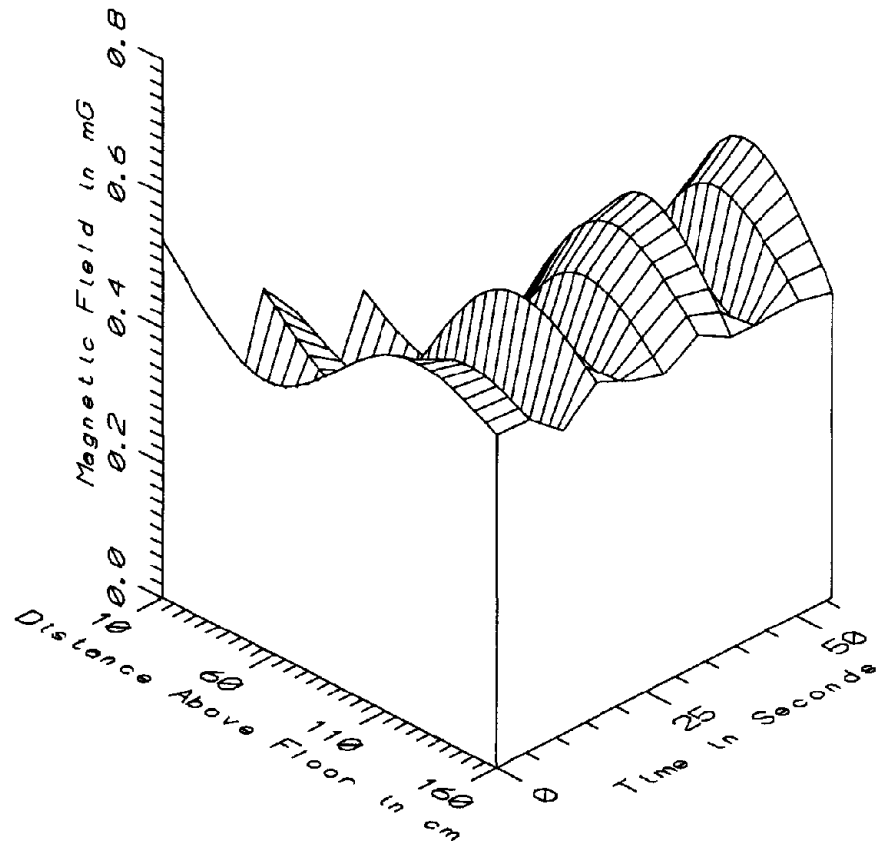

MET022 - CENTER OF PLATFORM AT SAFETY LINE - POWER HARM, 65-300Hz

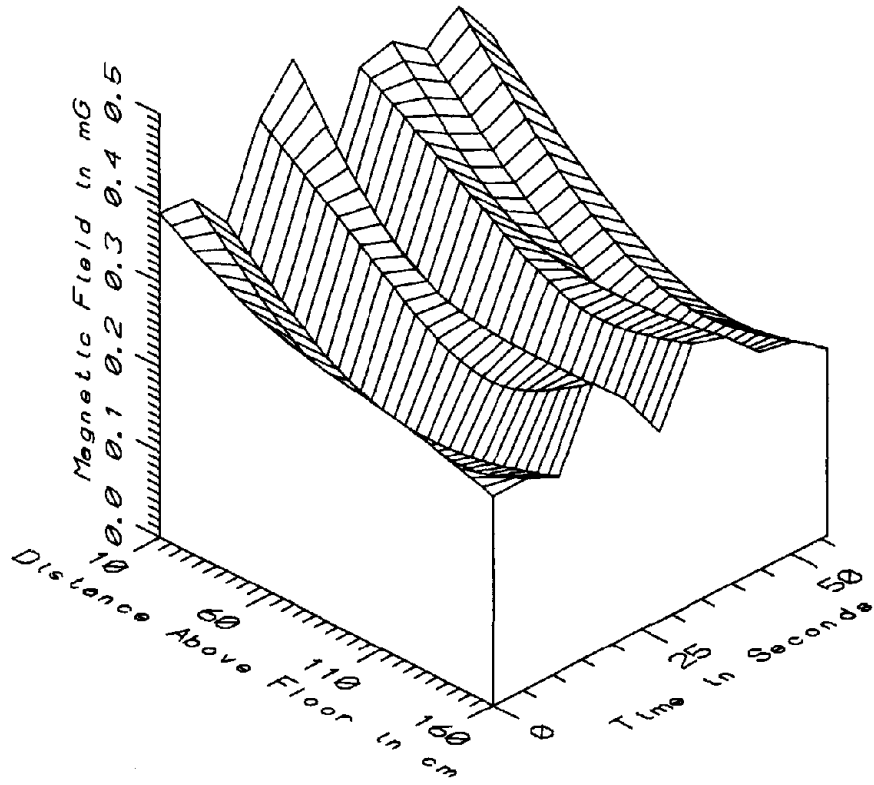

MET022 - CENTER OF PLATFORM AT SAFETY LINE - HIGH FREQ, 305-2560Hz

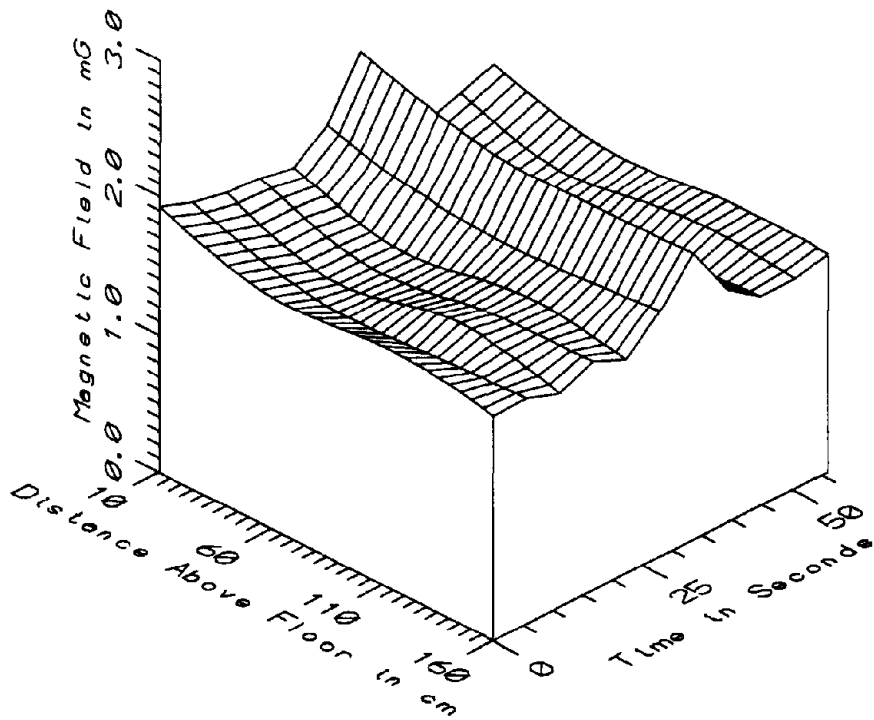

MET022 - CENTER OF PLATFORM AT SAFETY LINE - ALL FREQ, 5-2560Hz

MET022 - CENTER OF GROSVENOR PLATFORM, N. BOUND SIDE		TOTAL OF 11 SAMPLES				
FREQUENCY BAND	HEIGHT ABOVE FLOOR (cm)	MINIMUM MAGNETIC FIELD (mG)	MAXIMUM MAGNETIC FIELD (mG)	AVERAGE MAGNETIC FIELD (mG)	STANDARD DEVIATION (mG)	COEFFICIENT OF VARIATION (%)
STATIC	10	230.25	405.52	303.56	66.21	21.81
	60	273.69	336.83	296.76	22.98	7.74
	110	300.04	325.96	315.15	7.56	2.40
	160	405.62	434.30	419.36	8.39	2.00
5-45Hz	10	0.22	1.66	0.69	0.42	60.68
LOW FREQ	60	0.19	1.52	0.56	0.39	69.46
	110	0.09	1.28	0.46	0.34	75.01
	160	0.50	1.41	0.69	0.27	39.50
50-60Hz	10	1.49	1.65	1.59	0.06	3.76
PWR FREQ	60	1.36	1.49	1.43	0.04	2.82
	110	1.36	1.62	1.47	0.07	5.05
	160	1.32	1.46	1.39	0.04	3.16
65-300Hz	10	0.12	0.53	0.25	0.13	51.08
PWR HARM	60	0.17	0.40	0.24	0.07	30.70
	110	0.26	0.59	0.48	0.12	24.38
	160	0.45	0.50	0.47	0.02	3.74
305-2560Hz	10	0.33	0.49	0.41	0.05	12.17
HIGH FREQ	60	0.22	0.35	0.29	0.04	13.03
	110	0.20	0.28	0.24	0.04	15.65
	160	0.22	0.32	0.26	0.03	13.06
5-2560Hz	10	1.57	2.33	1.84	0.20	10.82
ALL FREQ	60	1.42	2.11	1.61	0.19	11.66
	110	1.45	2.05	1.67	0.15	9.01
	160	1.52	2.08	1.66	0.16	9.64

APPENDIX U

DATASET MET024  
GROSVENOR STATION, NORTH BOUND SIDE OF PLATFORM

Measurement Setup Code:        Staff:     24    Reference: 25  
   Drawing:  A-4

Vehicle Status:                NA

Measurement Date:              May 19, 1992

Measurement Time:            Start:     11:24:16  
   End:        11:25:12

Number of Samples:            10

Programmed Sample Interval:   5 sec

Actual Sample Interval:       6.2 sec

Frequency Spectrum Parameters

<u>Probe Type:</u>	<u>Wideband</u>	<u>Static</u>
Maximum Frequency (Hz)	2560	100
Minimum Frequency (Hz)	5	0
Spectral Bandwidth (Hz)	5	1

Missing Data: Wideband data from the reference probe

Saturated Data: None

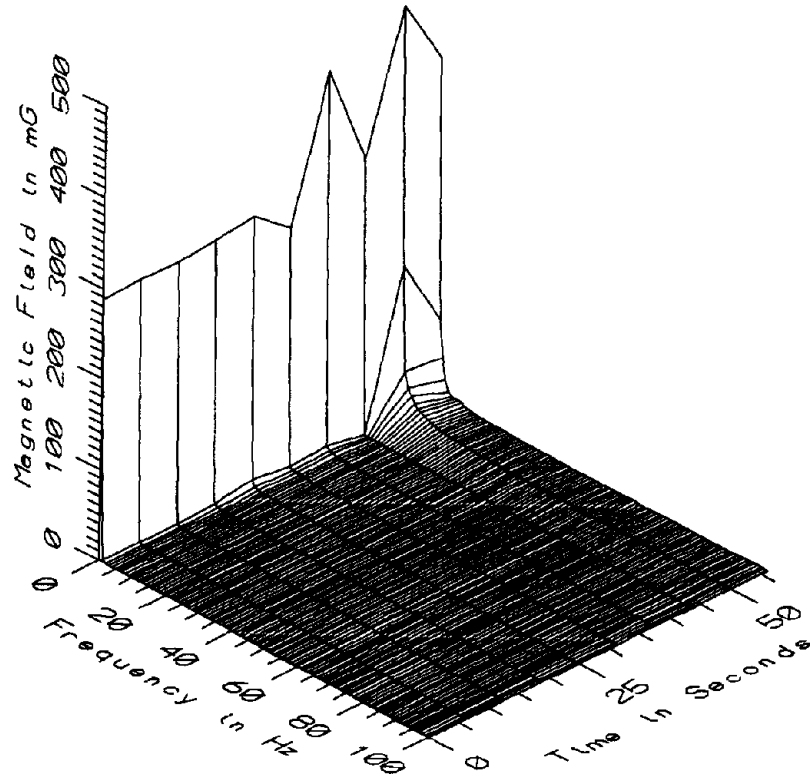

MET024 - 10cm ABOVE FLOOR, CENTER OF PLATFORM AT SAFETY LINE

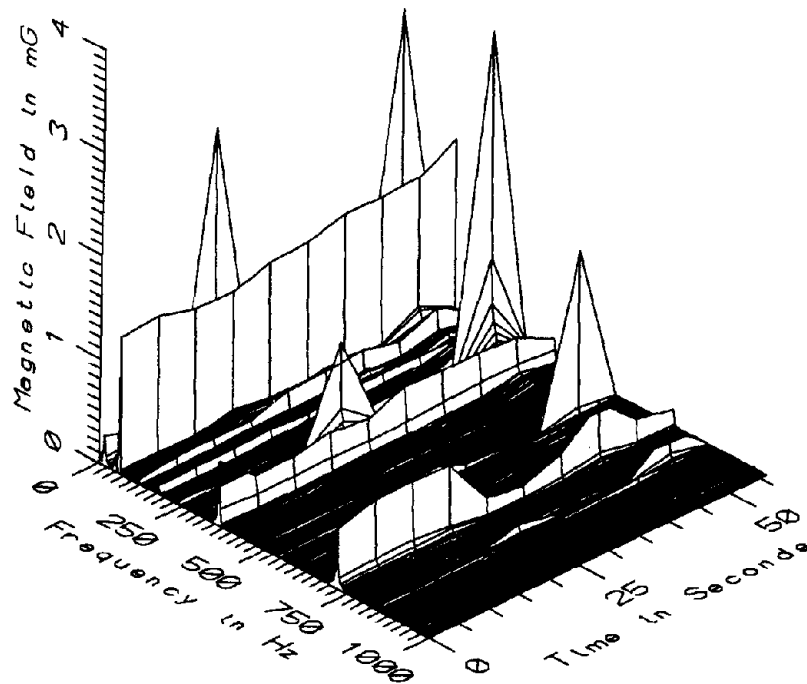

MET024 - 10cm ABOVE FLOOR, CENTER OF PLATFORM AT SAFETY LINE

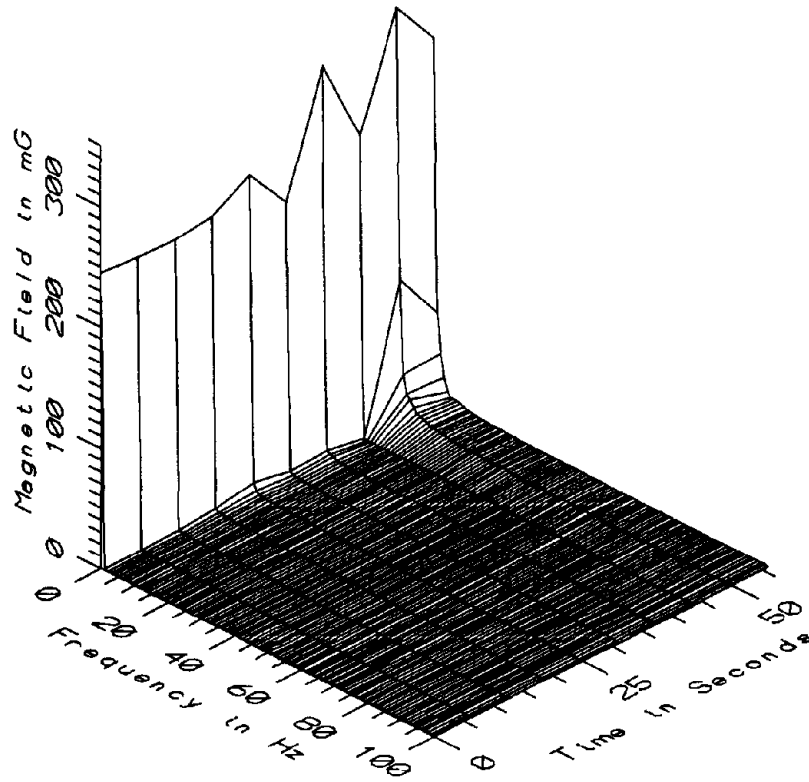

MET024 - 60cm ABOVE FLOOR, CENTER OF PLATFORM AT SAFETY LINE

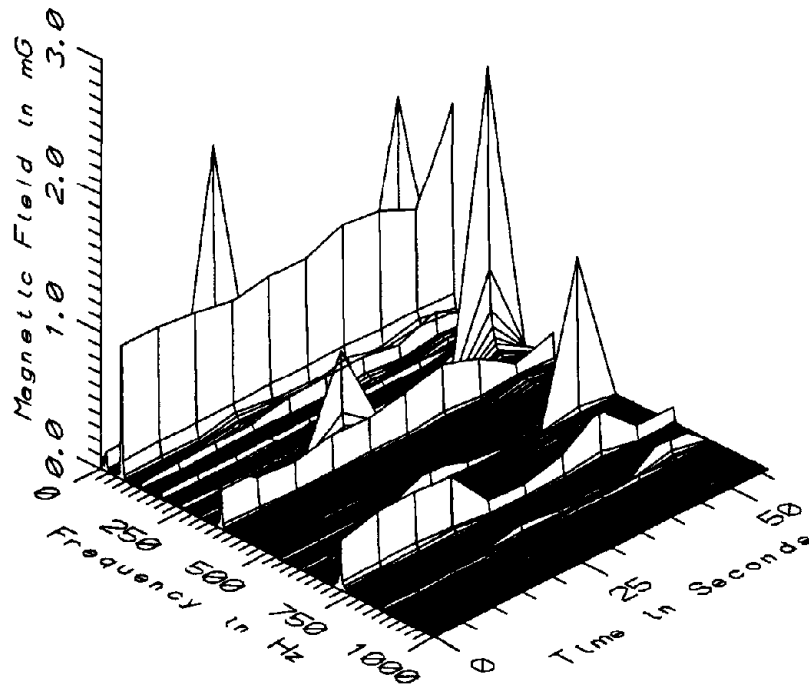

MET024 - 60cm ABOVE FLOOR, CENTER OF PLATFORM AT SAFETY LINE

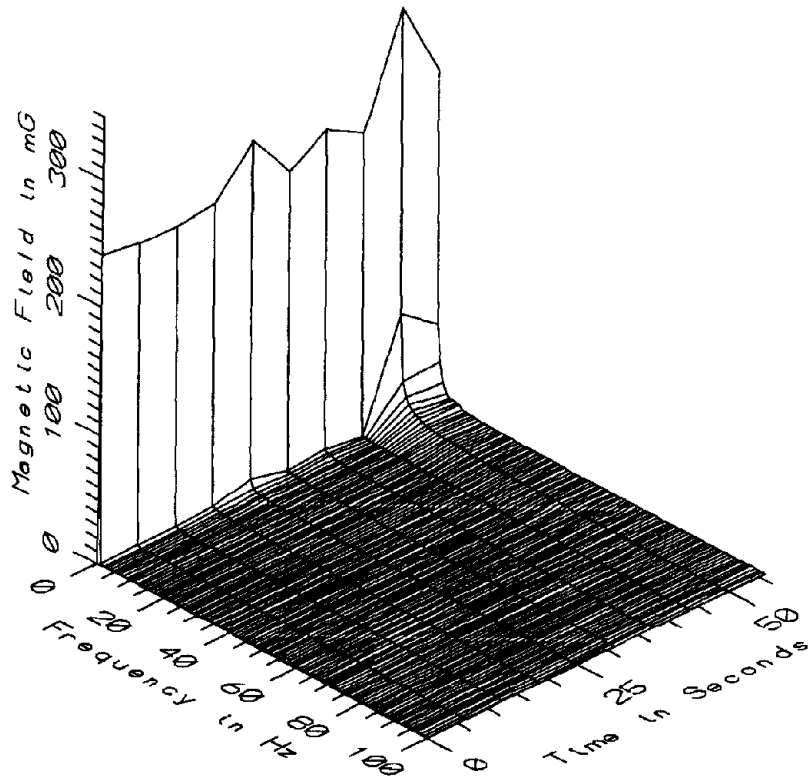

MET024 - 110cm ABOVE FLOOR, CENTER OF PLATFORM AT SAFETY LINE

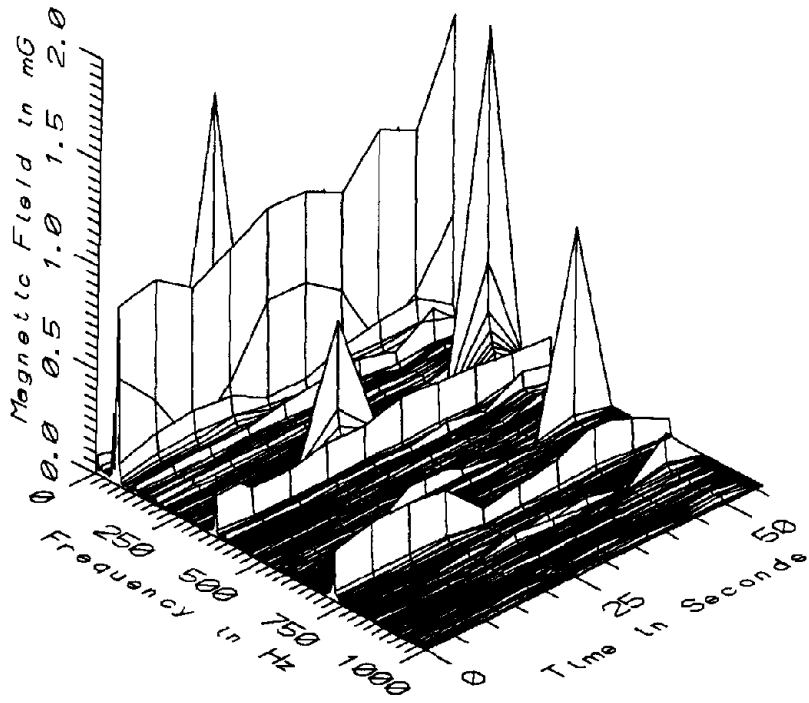

MET024 - 110cm ABOVE FLOOR, CENTER OF PLATFORM AT SAFETY LINE



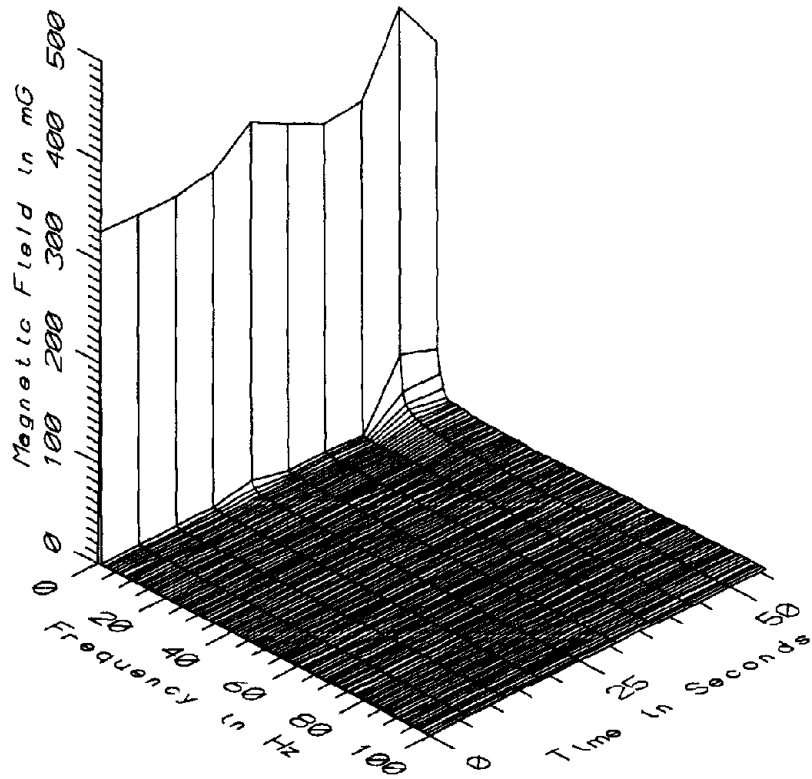

MET024 - 160cm ABOVE FLOOR, CENTER OF PLATFORM AT SAFETY LINE

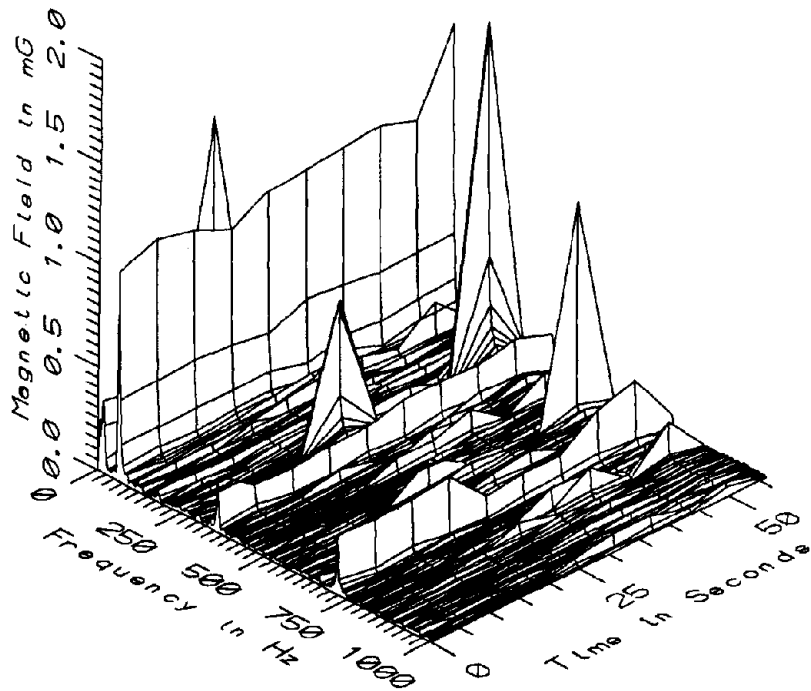

MET024 - 160cm ABOVE FLOOR, CENTER OF PLATFORM AT SAFETY LINE

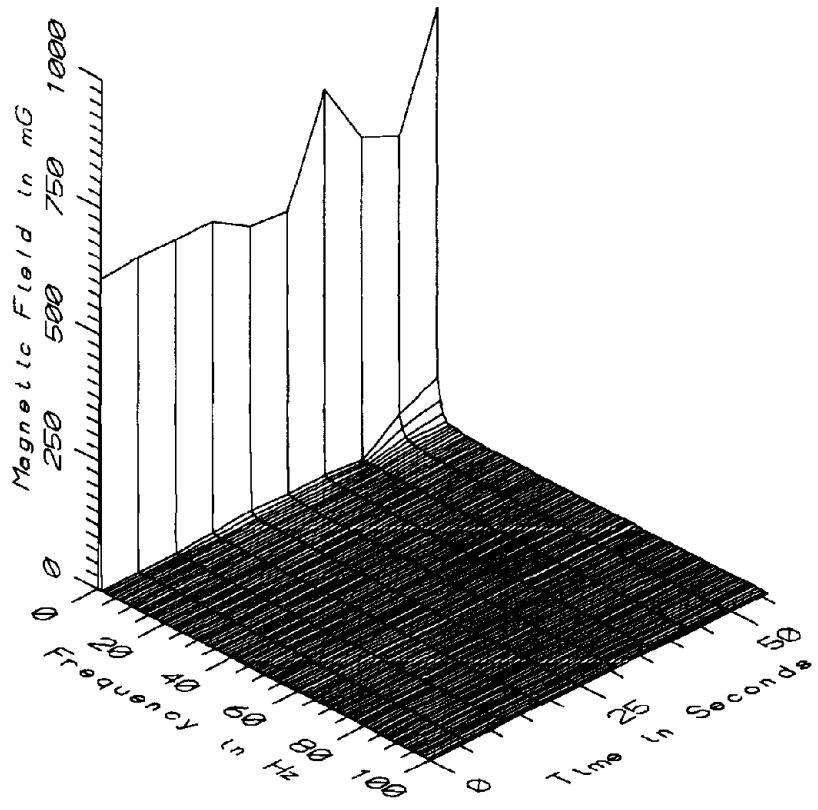

MET024 - REFERENCE PROBE - AT SAFETY LINE, NORTH BOUND SIDE

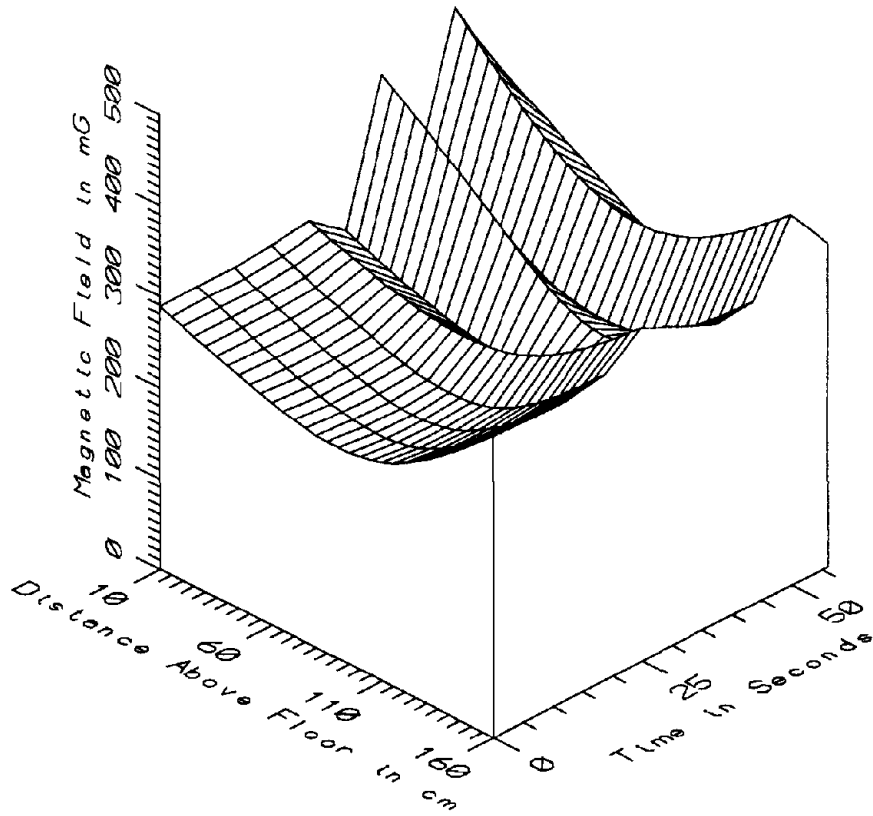

MET024 - CENTER OF PLATFORM AT SAFETY LINE - STATIC

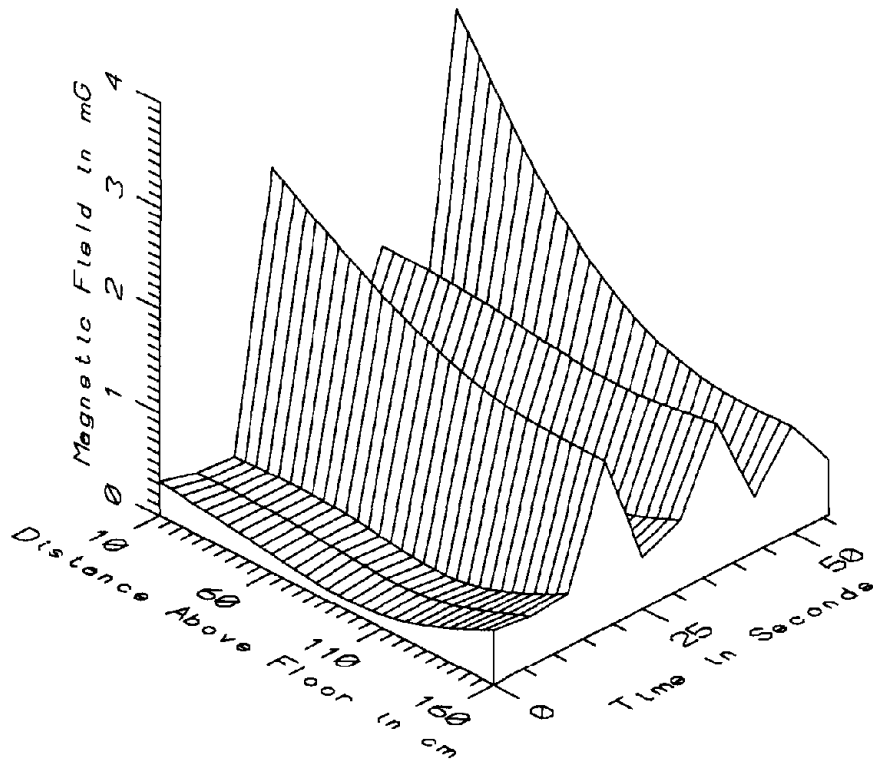

MET024 - CENTER OF PLATFORM AT SAFETY LINE - LOW FREQ, 5-45Hz

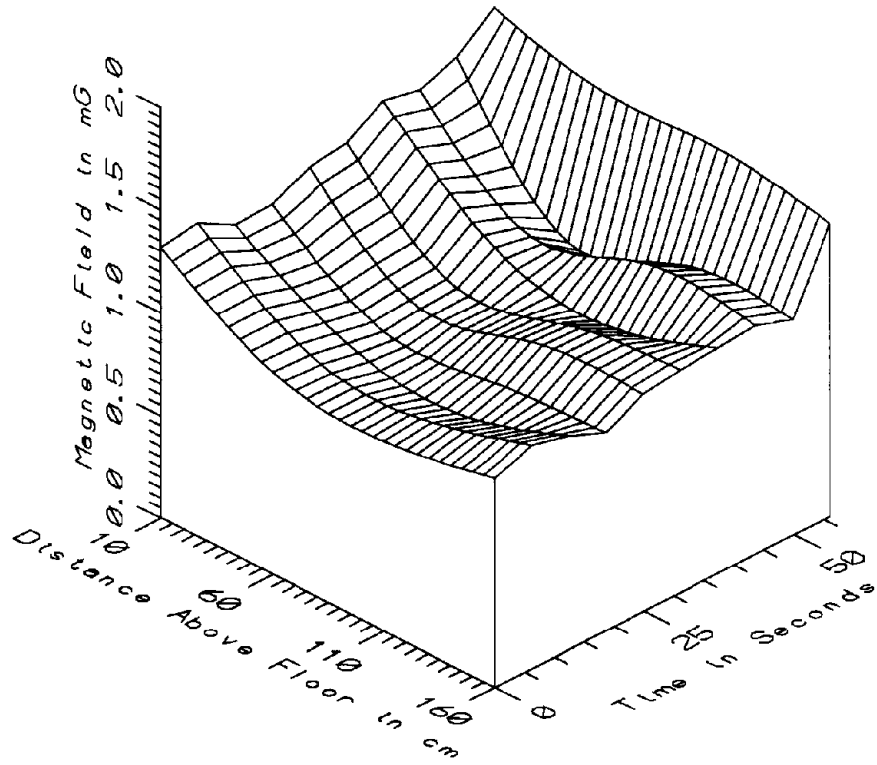

MET024 - CENTER OF PLATFORM AT SAFETY LINE - POWER FREQ, 50-60Hz

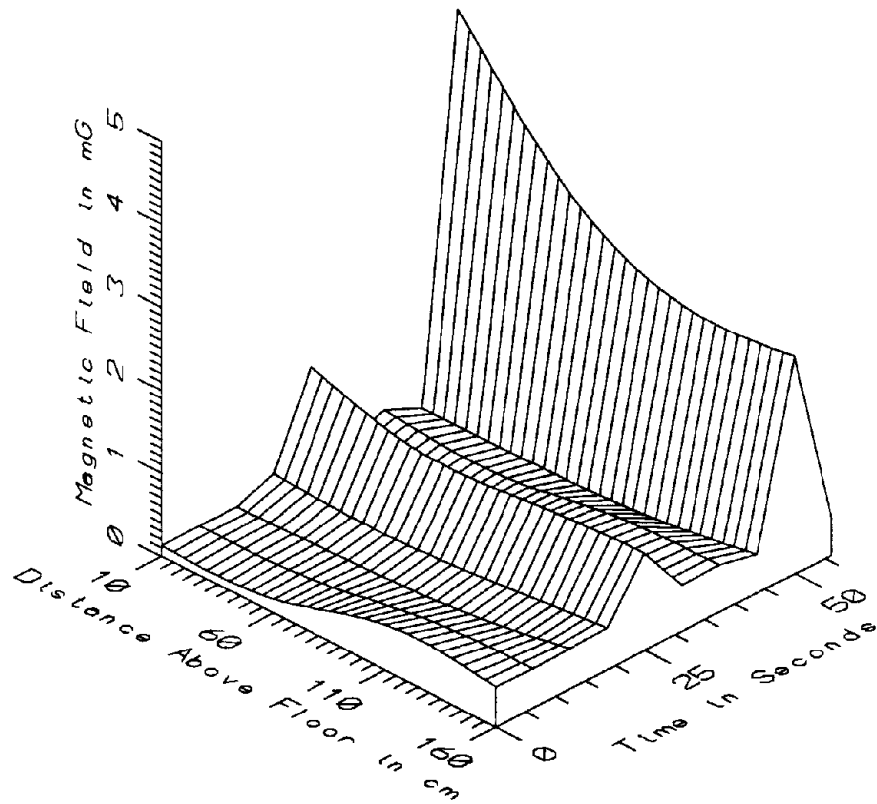

MET024 - CENTER OF PLATFORM AT SAFETY LINE - POWER HARM, 65-300Hz

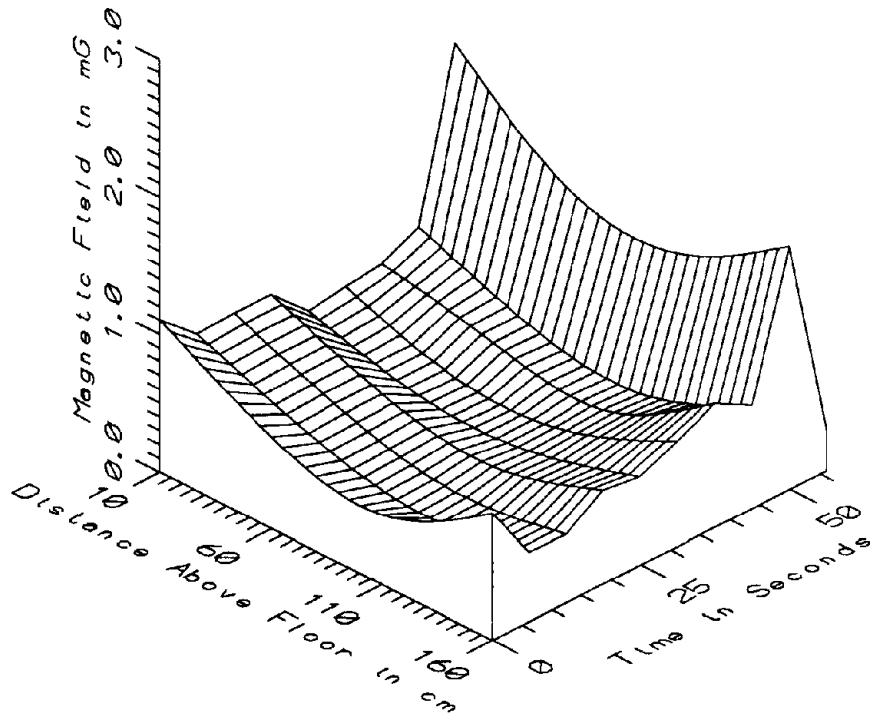

MET024 - CENTER OF PLATFORM AT SAFETY LINE - HIGH FREQ, 305-2560Hz

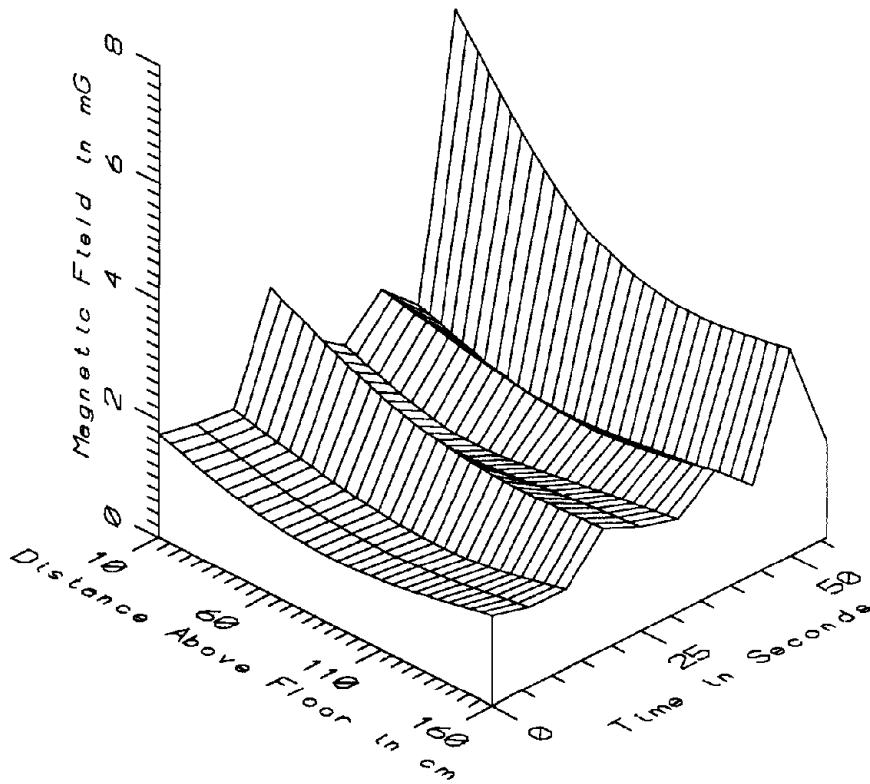

MET024 - CENTER OF PLATFORM AT SAFETY LINE - ALL FREQ, 5-2560Hz

MET024 - CENTER OF GROSVENOR PLATFORM, N. BOUND SIDE		TOTAL OF 10 SAMPLES				
FREQUENCY BAND	HEIGHT ABOVE FLOOR (cm)	MINIMUM MAGNETIC FIELD (mG)	MAXIMUM MAGNETIC FIELD (mG)	AVERAGE MAGNETIC FIELD (mG)	STANDARD DEVIATION (mG)	COEFFICIENT OF VARIATION (%)
STATIC	10	267.75	452.42	328.23	63.87	19.46
	60	226.00	340.70	267.73	39.35	14.70
	110	234.84	322.10	253.65	27.38	10.80
	160	328.16	407.32	346.02	25.13	7.26
5-45Hz LOW FREQ	10	0.21	3.45	1.06	1.18	111.37
	60	0.17	2.12	0.74	0.77	103.43
	110	0.10	1.69	0.56	0.59	105.95
	160	0.48	1.62	0.78	0.42	54.02
50-60Hz PWR FREQ	10	1.25	1.66	1.40	0.13	9.22
	60	0.89	1.52	1.01	0.18	18.22
	110	0.87	1.52	1.04	0.19	18.21
	160	0.96	1.43	1.09	0.13	11.60
65-300Hz PWR HARM	10	0.13	4.78	0.79	1.45	182.86
	60	0.17	3.24	0.60	0.96	159.68
	110	0.26	2.57	0.71	0.70	97.81
	160	0.47	2.64	0.78	0.69	88.03
305-2560Hz HIGH FREQ	10	0.41	2.02	0.90	0.44	48.89
	60	0.31	1.39	0.59	0.30	50.34
	110	0.25	1.31	0.50	0.29	57.68
	160	0.30	1.77	0.78	0.40	51.08
5-2560Hz ALL FREQ	10	1.55	6.41	2.41	1.49	61.90
	60	1.13	4.09	1.73	0.93	53.80
	110	1.00	3.27	1.61	0.67	41.25
	160	1.35	3.50	1.84	0.64	34.53

APPENDIX V

DATASET MET025  
GROSVENOR STATION, NORTH BOUND SIDE OF PLATFORM

Measurement Setup Code:        Staff:    26    Reference: 27  
   Drawing: A-4

Vehicle Status:                NA

Measurement Date:              May 19, 1992

Measurement Time:              Start:    11:27:03  
   End:      11:30:43

Number of Samples:            41

Programmed Sample Interval:   5 sec

Actual Sample Interval:       5.5 sec

Frequency Spectrum Parameters

<u>Probe Type:</u>	<u>Wideband</u>	<u>Static</u>
Maximum Frequency (Hz)	2560	100
Minimum Frequency (Hz)	5	0
Spectral Bandwidth (Hz)	5	1

Missing Data: Wideband data from the reference probe

Saturated Data: None

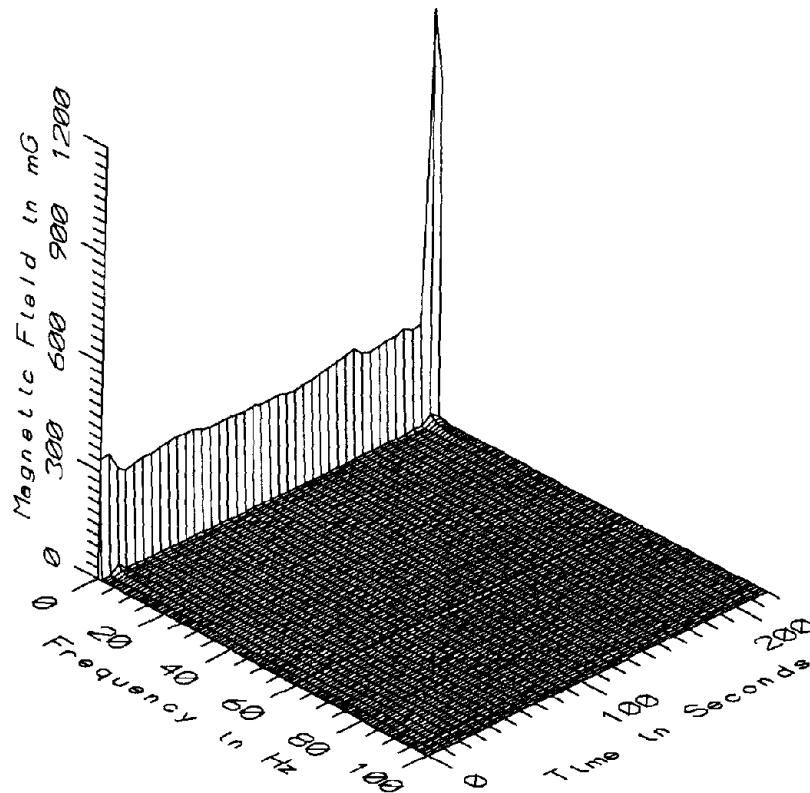

MET025 - 0cm FROM SAFETY LINE, 1M ABOVE CENTER OF PLATFORM

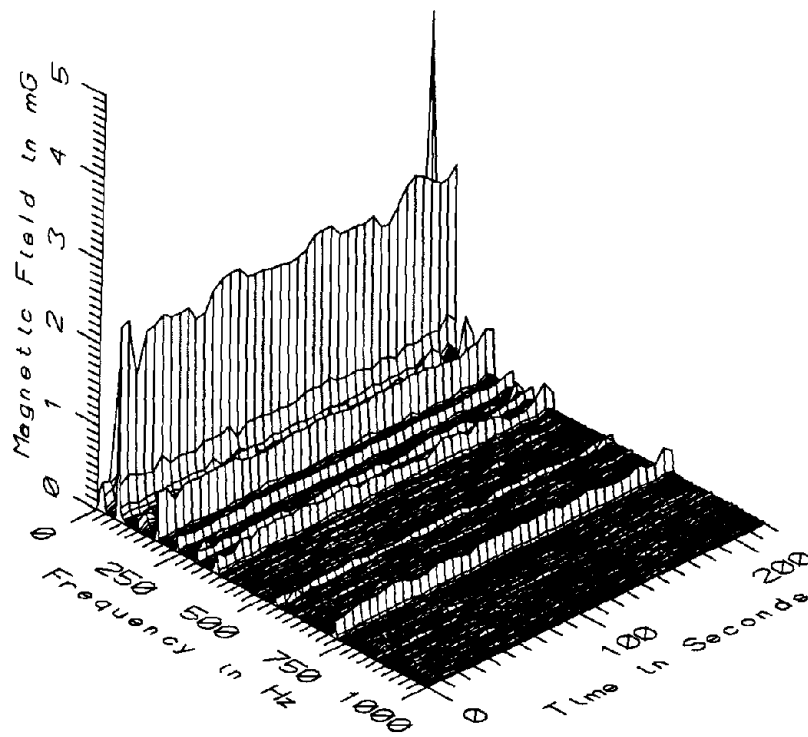

MET025 - 0cm FROM SAFETY LINE, 1M ABOVE CENTER OF PLATFORM



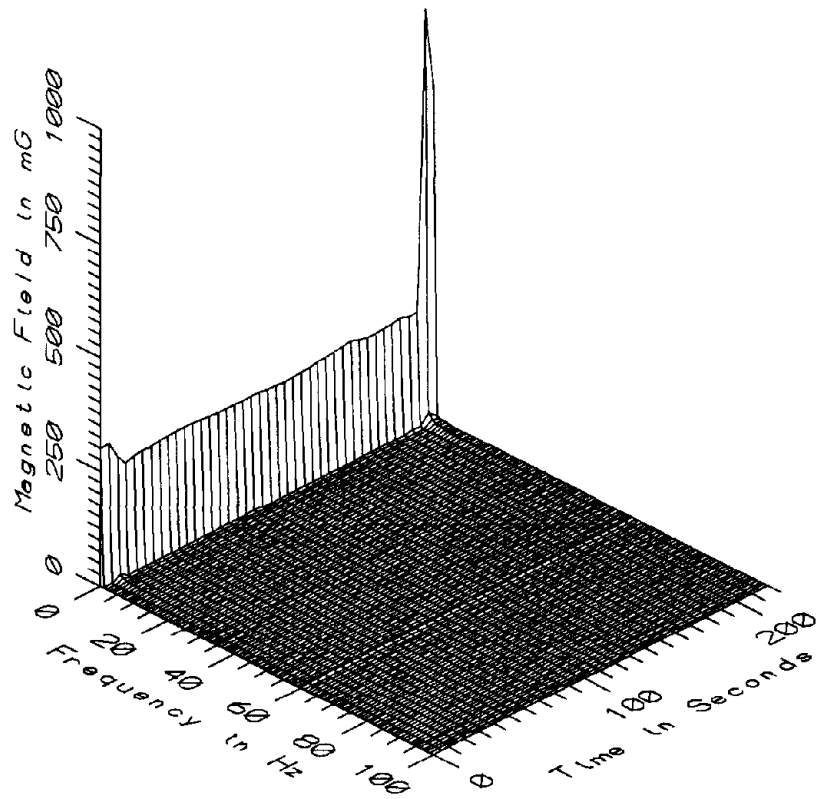

MET025 - 50cm FROM SAFETY LINE, 1M ABOVE CENTER OF PLATFORM

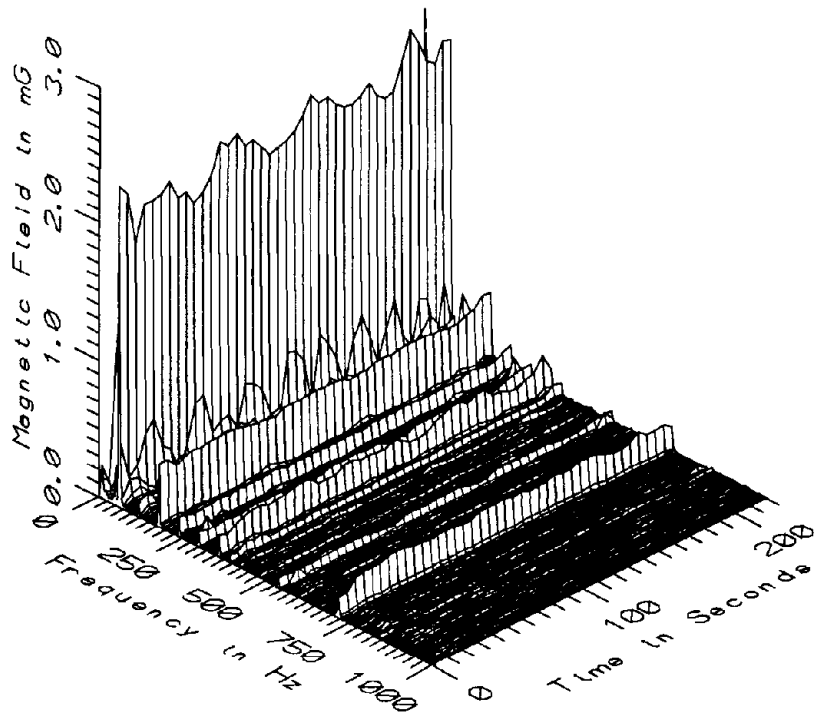

MET025 - 50cm FROM SAFETY LINE, 1M ABOVE CENTER OF PLATFORM

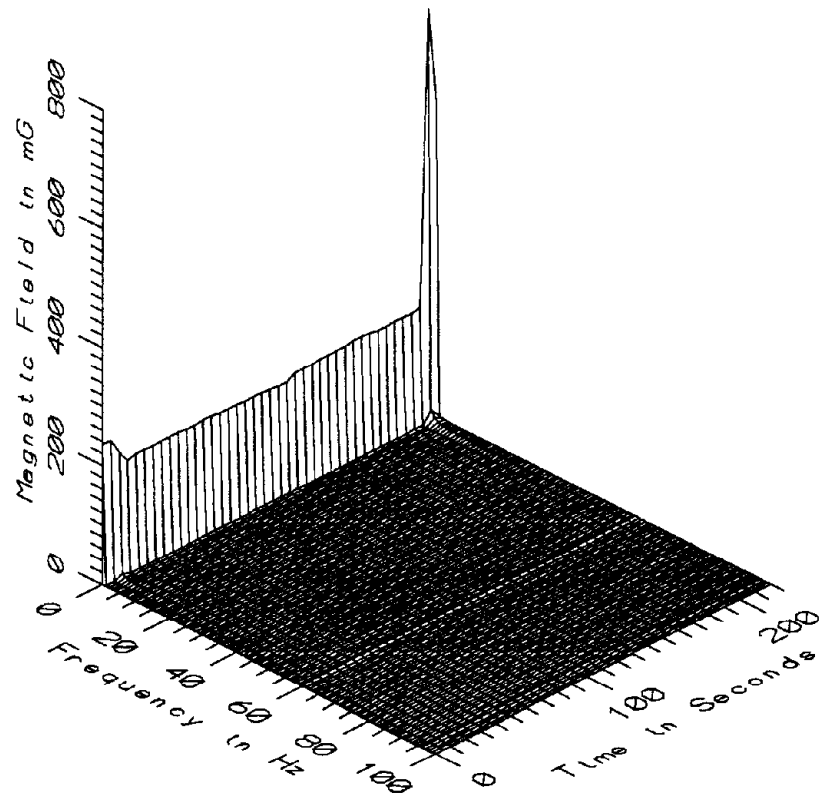

MET025 - 100cm FROM SAFETY LINE, 1M ABOVE CENTER OF PLATFORM

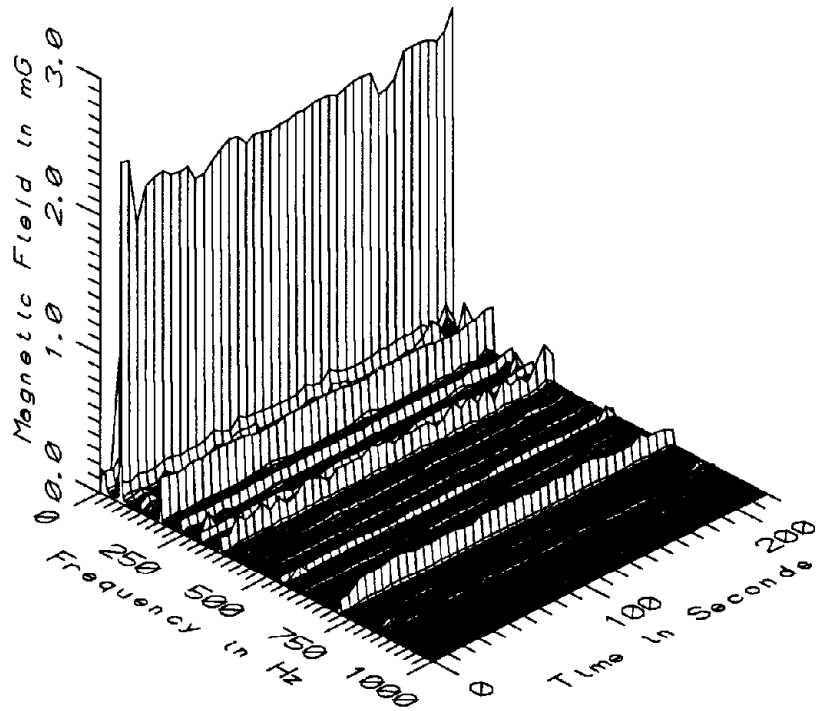

MET025 - 100cm FROM SAFETY LINE, 1M ABOVE CENTER OF PLATFORM

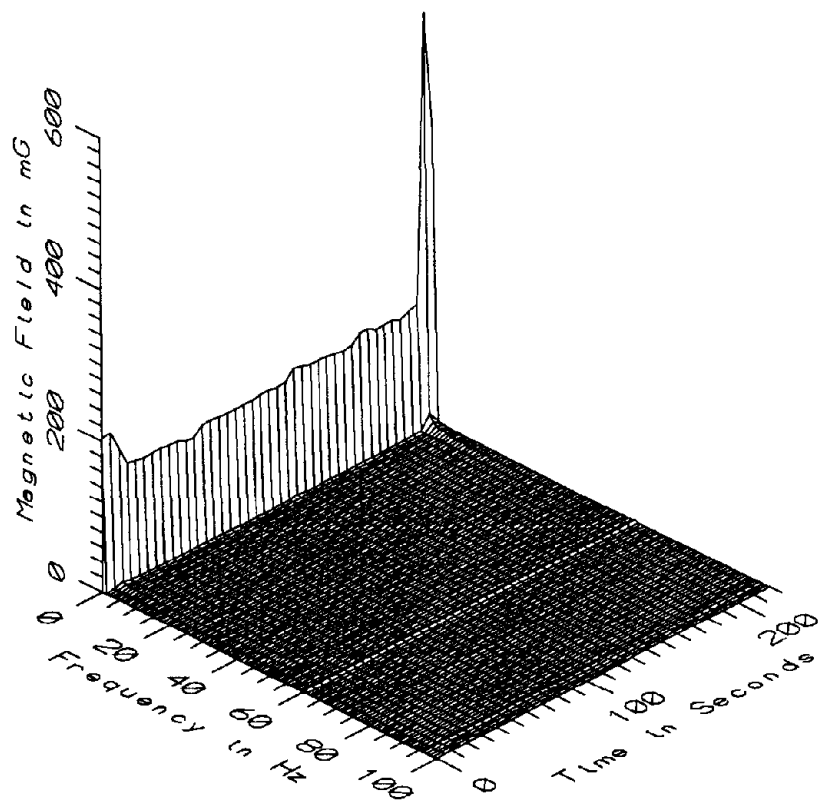

MET025 - 150cm FROM SAFETY LINE, 1M ABOVE CENTER OF PLATFORM

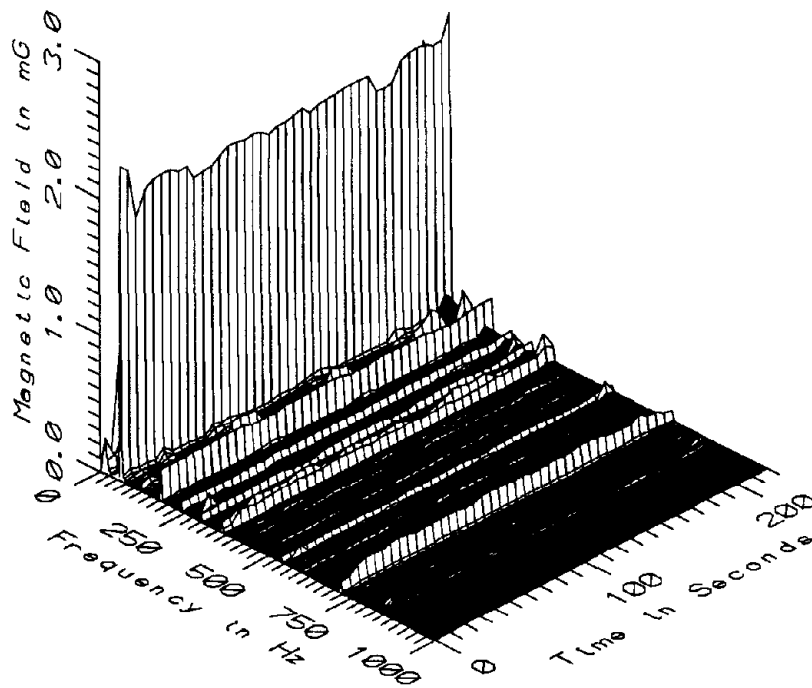

MET025 - 150cm FROM SAFETY LINE, 1M ABOVE CENTER OF PLATFORM

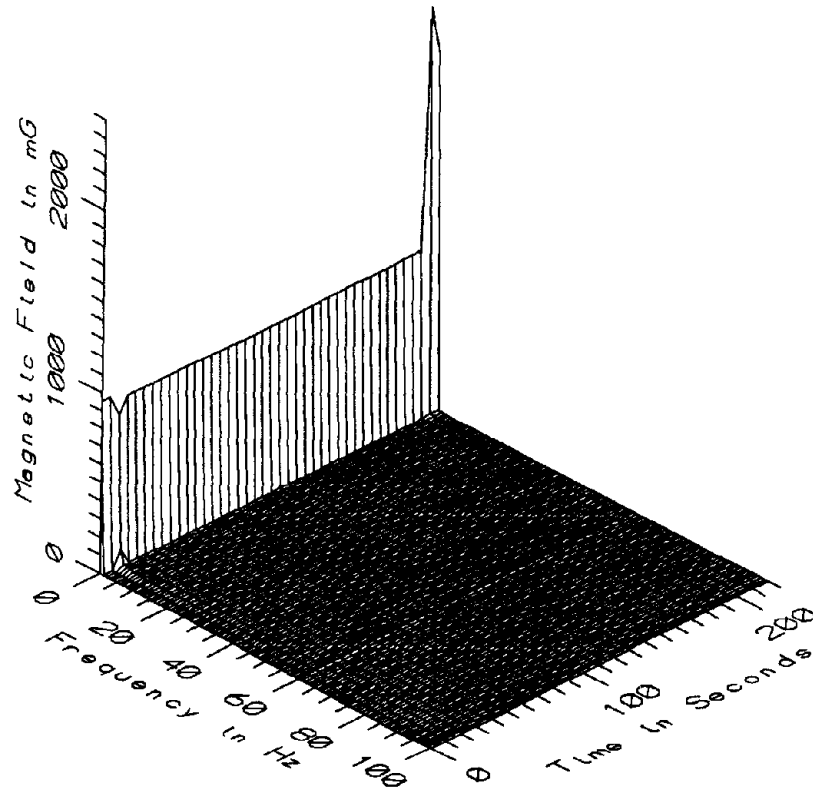

MET025 - REFERENCE PROBE - AT SAFETY LINE, SOUTH BOUND SIDE

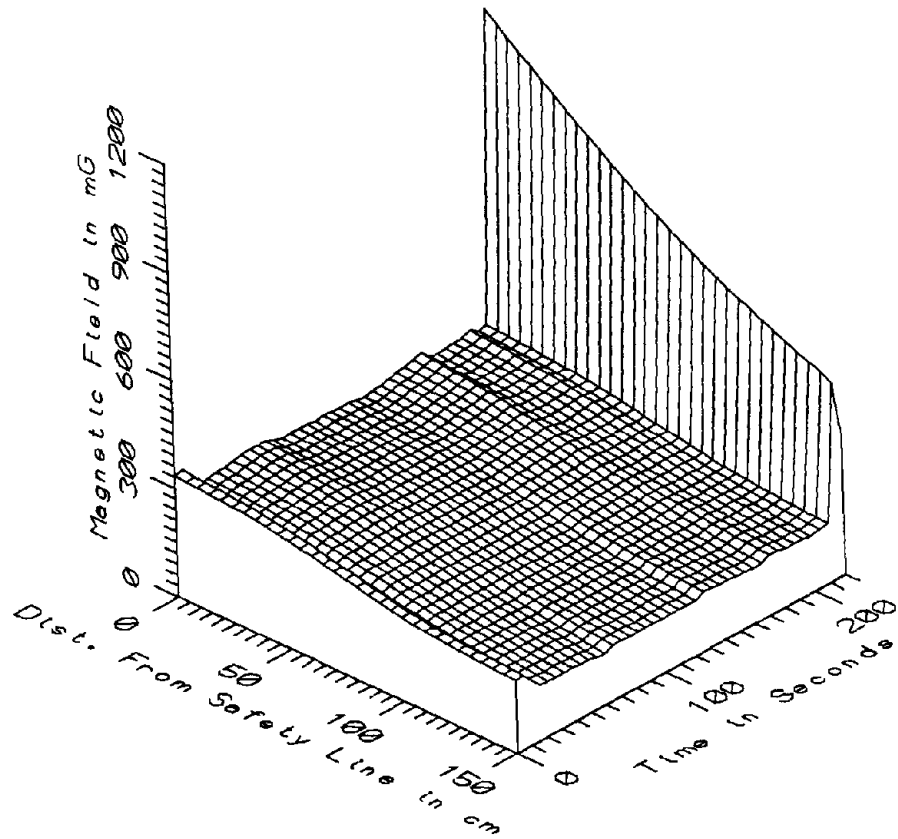

MET025 - 1M ABOVE CENTER OF PLATFORM - STATIC

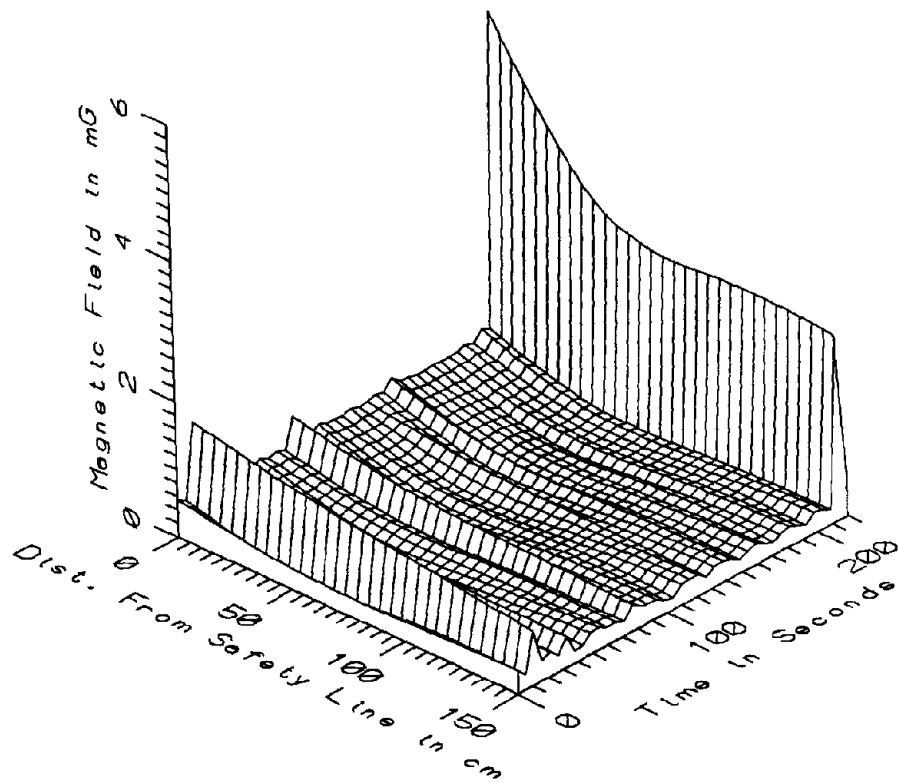

MET025 - 1M ABOVE CENTER OF PLATFORM - LOW FREQ. 5-45Hz

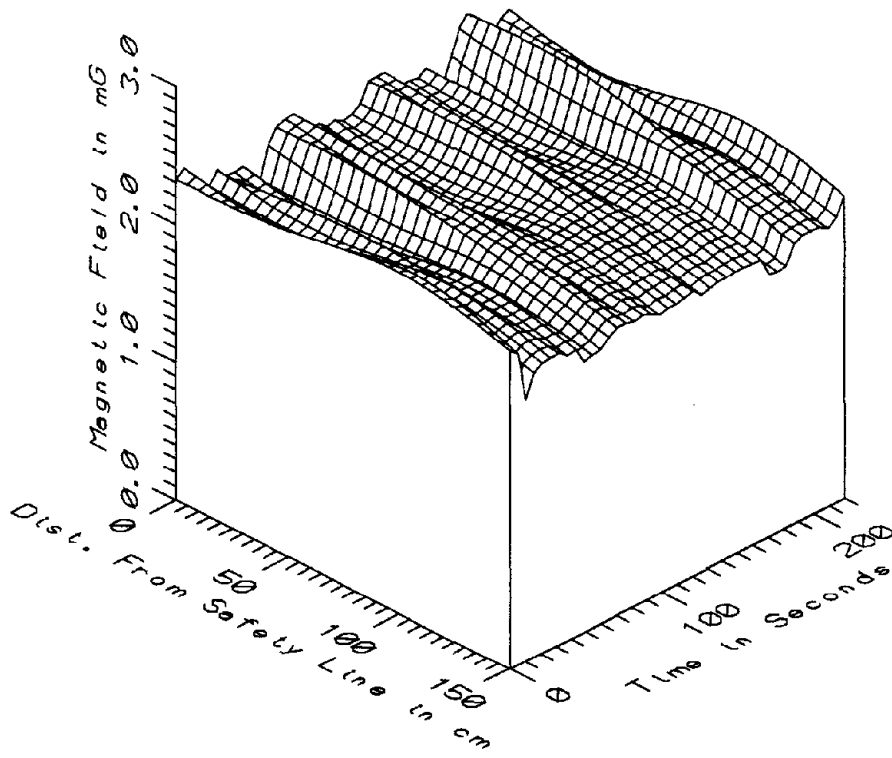

MET025 - 1M ABOVE CENTER OF PLATFORM - POWER FREQ, 50-60Hz

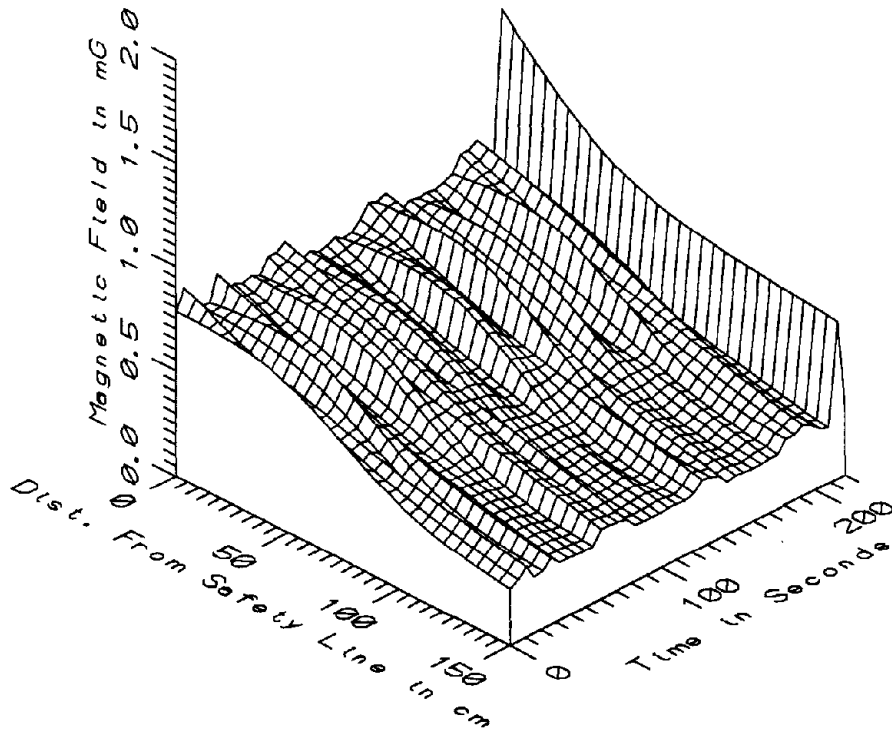

MET025 - 1M ABOVE CENTER OF PLATFORM - POWER HARM, 65-300Hz

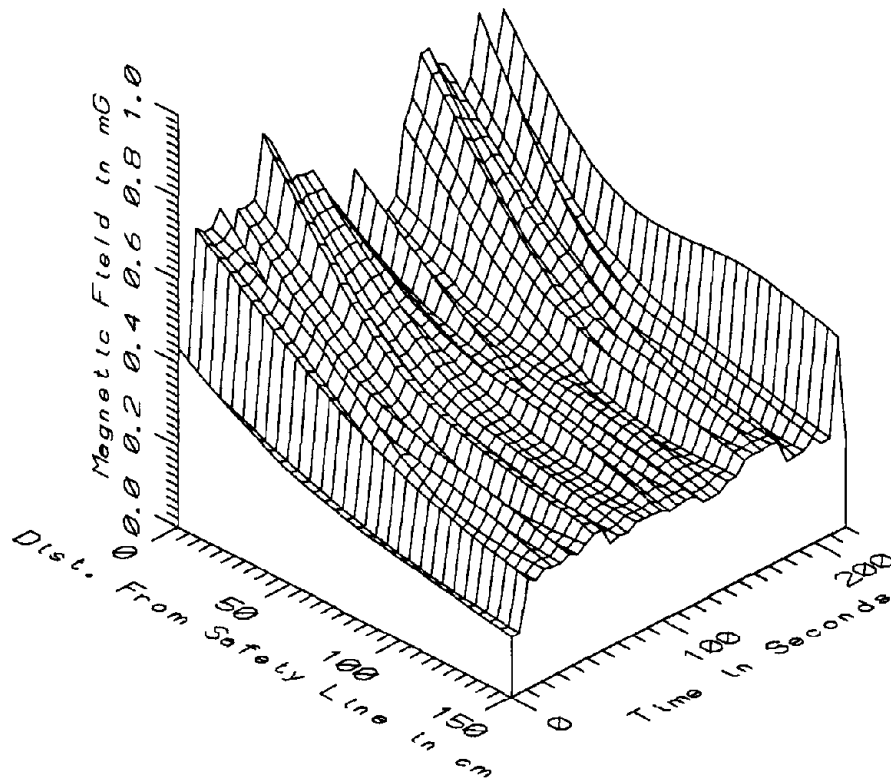

MET025 - 1M ABOVE CENTER OF PLATFORM - HIGH FREQ, 305-2560Hz

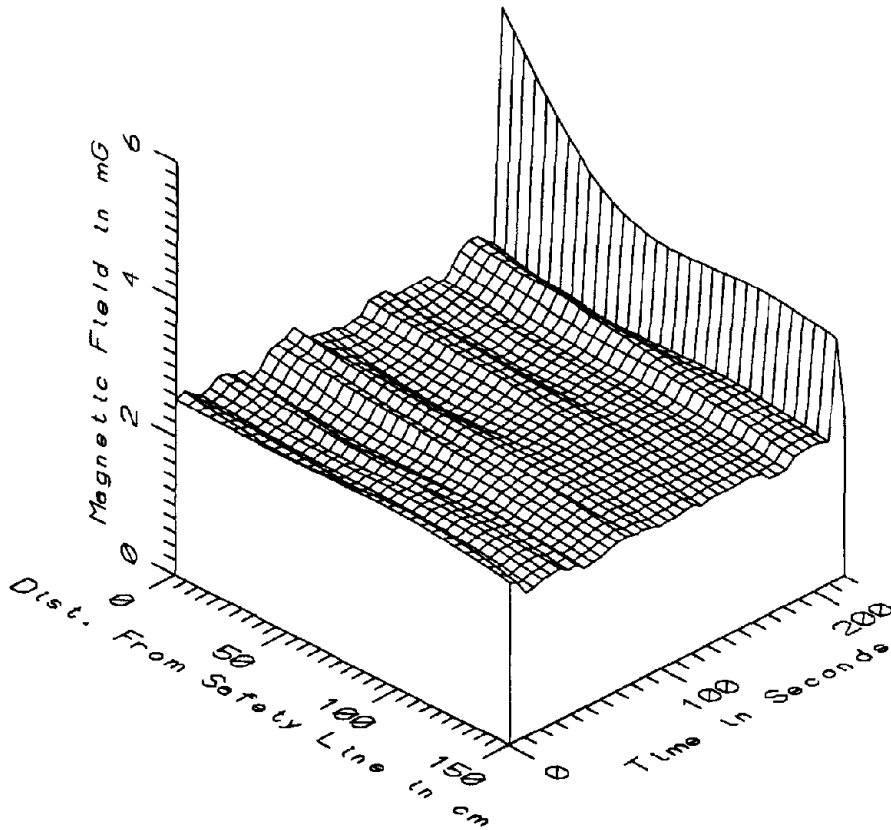

MET025 - 1M ABOVE CENTER OF PLATFORM - ALL FREQ, 5-2560Hz

MET025 - CENTER OF GROSVENOR PLATFORM, N. BOUND SIDE TOTAL OF 41 SAMPLES						
FREQUENCY BAND	DIST FROM LINE (cm)	MINIMUM MAGNETIC FIELD (mG)	MAXIMUM MAGNETIC FIELD (mG)	AVERAGE MAGNETIC FIELD (mG)	STANDARD DEVIATION (mG)	COEFFICIENT OF VARIATION (%)
STATIC	0	264.90	1144.56	320.38	167.70	52.34
	50	240.40	899.01	279.88	123.35	44.07
	100	186.44	695.18	215.62	93.30	43.27
	150	142.01	543.27	173.65	70.08	40.36
5-45Hz LOW FREQ	0	0.44	5.12	0.70	0.75	107.57
	50	0.05	2.93	0.29	0.49	169.56
	100	0.16	2.73	0.32	0.42	132.83
	150	0.17	2.70	0.35	0.39	111.73
50-60Hz PWR FREQ	0	1.65	2.45	2.21	0.14	6.43
	50	1.88	2.44	2.17	0.11	5.23
	100	1.95	2.47	2.19	0.10	4.34
	150	1.88	2.30	2.04	0.08	3.92
65-300Hz PWR HARM	0	0.72	1.45	0.80	0.12	14.66
	50	0.50	0.97	0.64	0.08	13.25
	100	0.37	0.82	0.42	0.07	17.01
	150	0.26	0.75	0.30	0.08	25.59
305-2560Hz HIGH FREQ	0	0.39	0.88	0.68	0.12	17.66
	50	0.26	0.56	0.43	0.06	13.88
	100	0.18	0.53	0.31	0.05	16.83
	150	0.14	0.47	0.26	0.05	17.91
5-2560Hz ALL FREQ	0	2.29	5.86	2.60	0.54	20.67
	50	2.15	3.86	2.36	0.26	11.18
	100	2.09	3.67	2.31	0.24	10.32
	150	1.95	3.51	2.14	0.23	10.95



APPENDIX W

DATASET MET026  
IN FRONT OF OPERATOR'S SEAT IN A 2000 SERIES CAR

Measurement Setup Code:      Staff:    8      Reference: -  
   Drawing: A-1

Vehicle Status:                    Traveling on the Green Line

Measurement Date:                May 19, 1992

Measurement Time:                Start:    15:31:20  
   End:      15:32:53

Number of Samples:                9

Programmed Sample Interval:    5 sec

Actual Sample Interval:         11.6 sec

Frequency Spectrum Parameters

<u>Probe Type:</u>	<u>Wideband</u>	<u>Static</u>
Maximum Frequency (Hz)	2560	100
Minimum Frequency (Hz)	5	0
Spectral Bandwidth (Hz)	5	1

Missing Data: No reference probe

Saturated Data - Wideband:	<u>Sensor</u>	<u>Sample</u>	<u>Time (sec)</u>
	10cm	5	46
	60cm	4	35
	110cm	4	35
	160cm	4	35

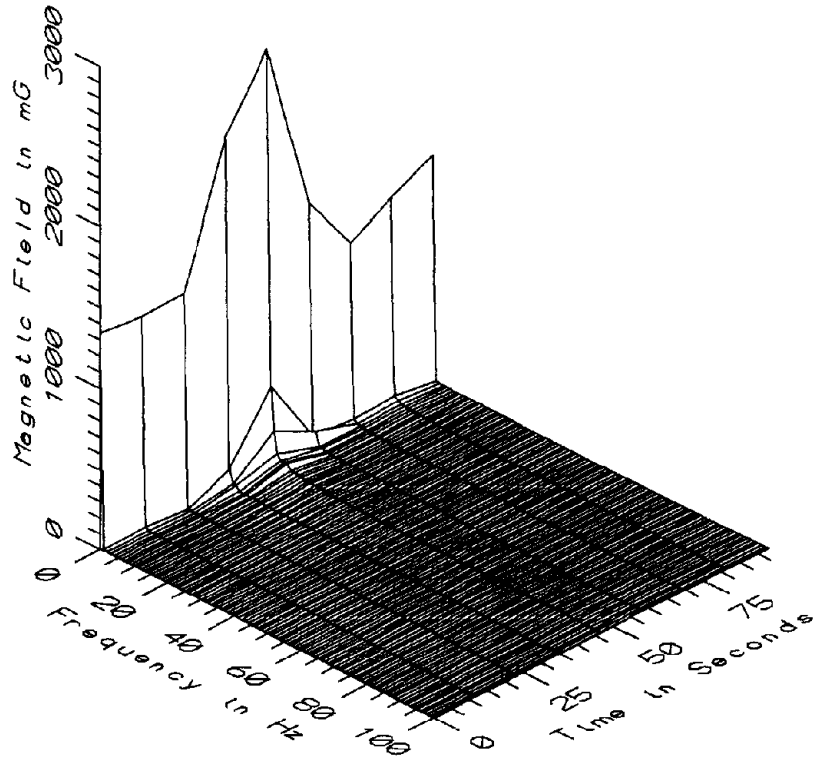

MET026 - 10cm ABOVE FLOOR, IN FRONT OF OPERATOR'S SEAT, CAR 2XXX

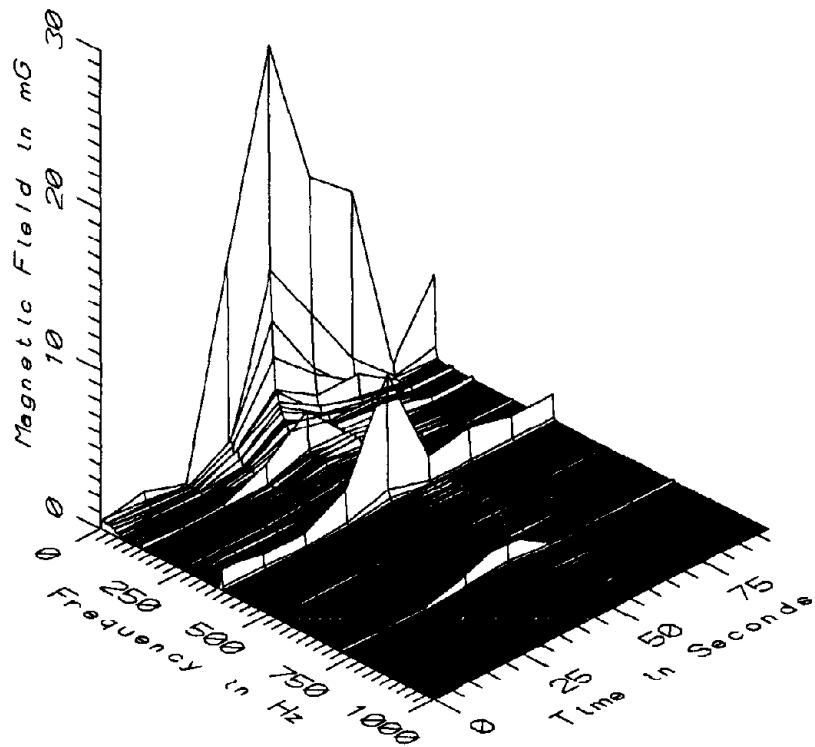

MET026 - 10cm ABOVE FLOOR, IN FRONT OF OPERATOR'S SEAT, CAR 2XXX

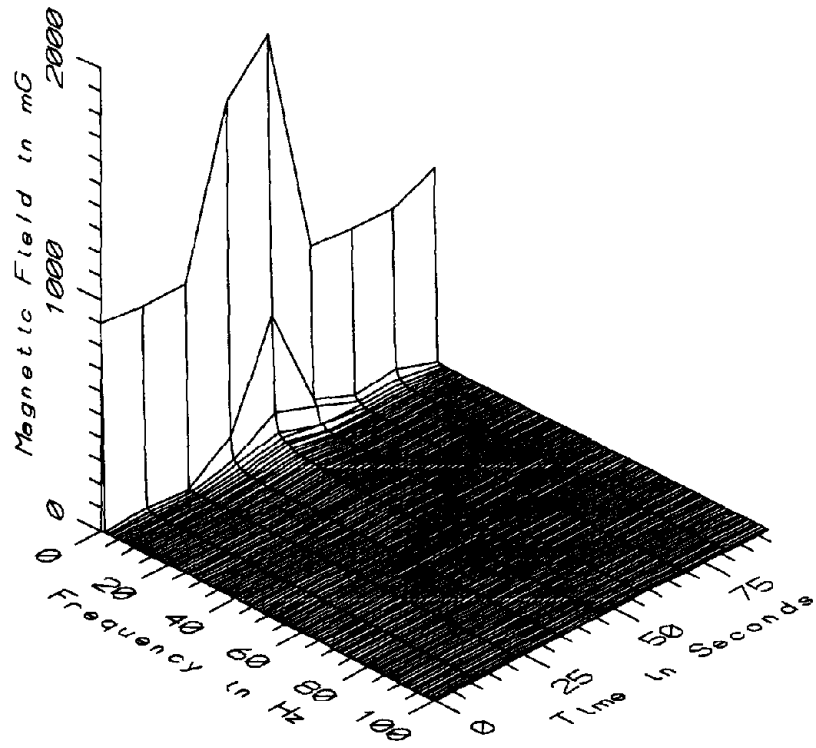

MET026 - 60cm ABOVE FLOOR, IN FRONT OF OPERATOR'S SEAT, CAR 2XXX

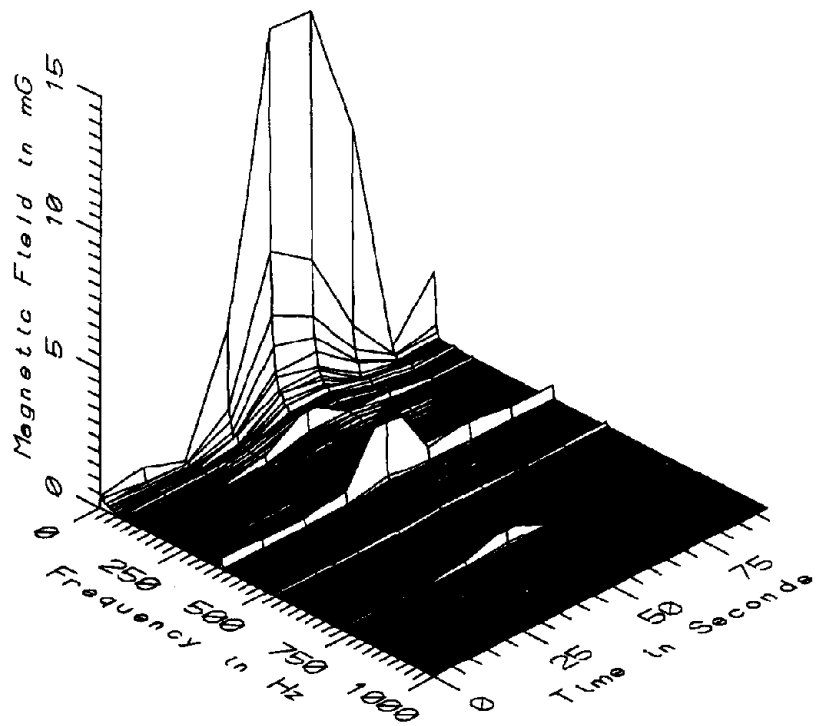

MET026 - 60cm ABOVE FLOOR, IN FRONT OF OPERATOR'S SEAT, CAR 2XXX

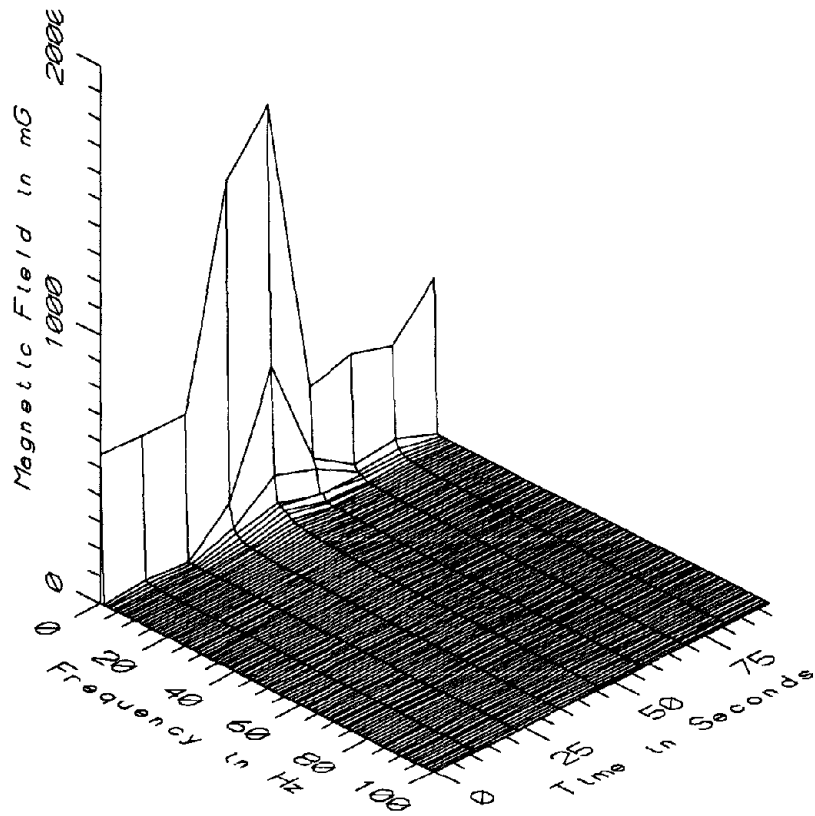

MET026 - 110cm ABOVE FLOOR, IN FRONT OF OPERATOR'S SEAT, CAR 2XXX

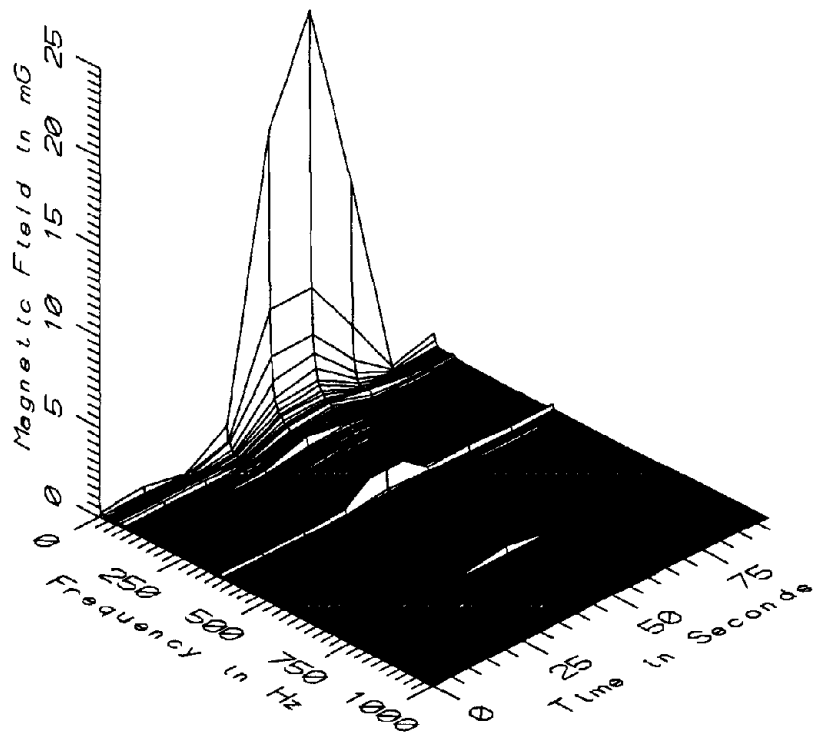

MET026 - 110cm ABOVE FLOOR, IN FRONT OF OPERATOR'S SEAT, CAR 2XXX

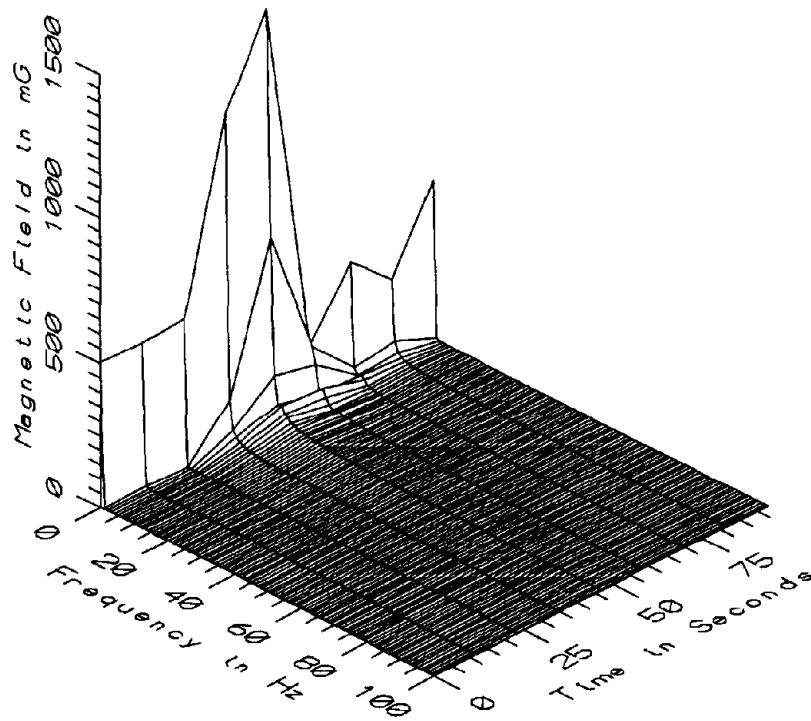

MET026 - 160cm ABOVE FLOOR, IN FRONT OF OPERATOR'S SEAT, CAR 2XXX

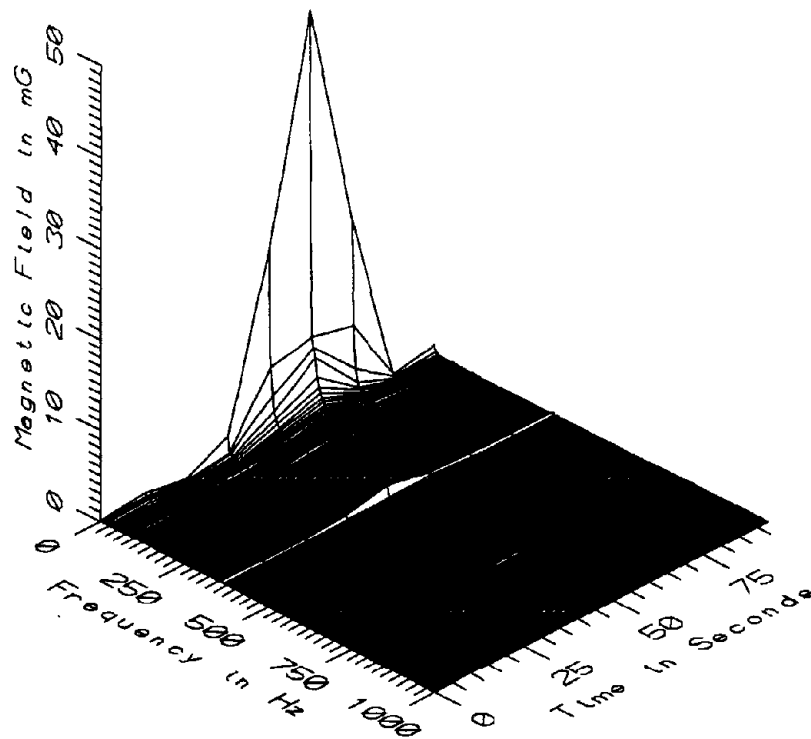

MET026 - 160cm ABOVE FLOOR, IN FRONT OF OPERATOR'S SEAT, CAR 2XXX

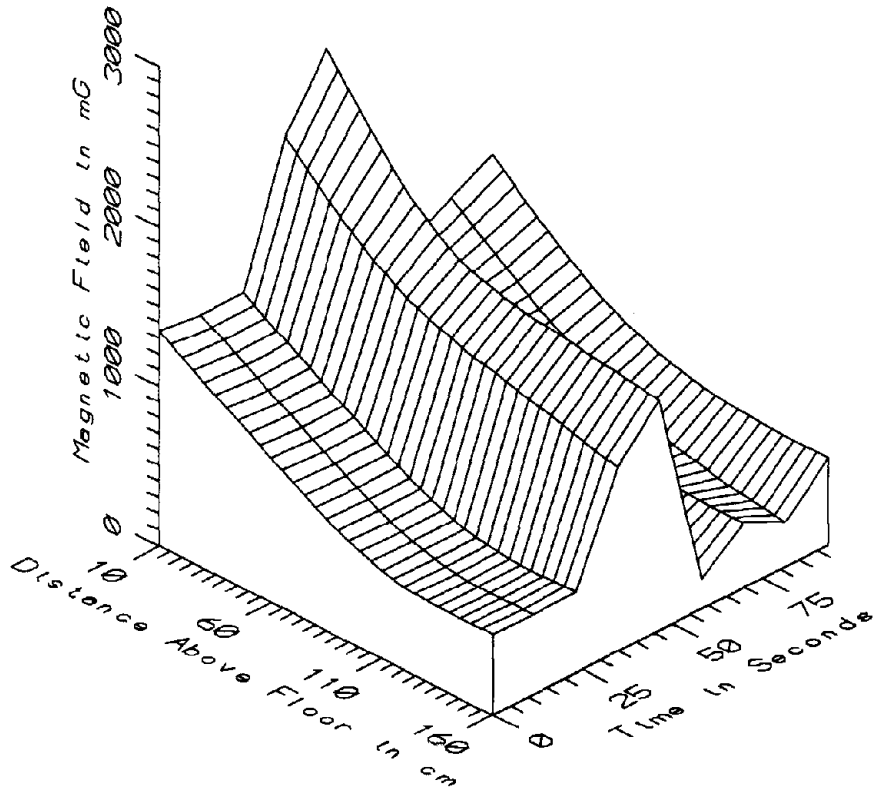

MET026 - IN FRONT OF OPERATOR'S SEAT, CAR 2XXX - STATIC

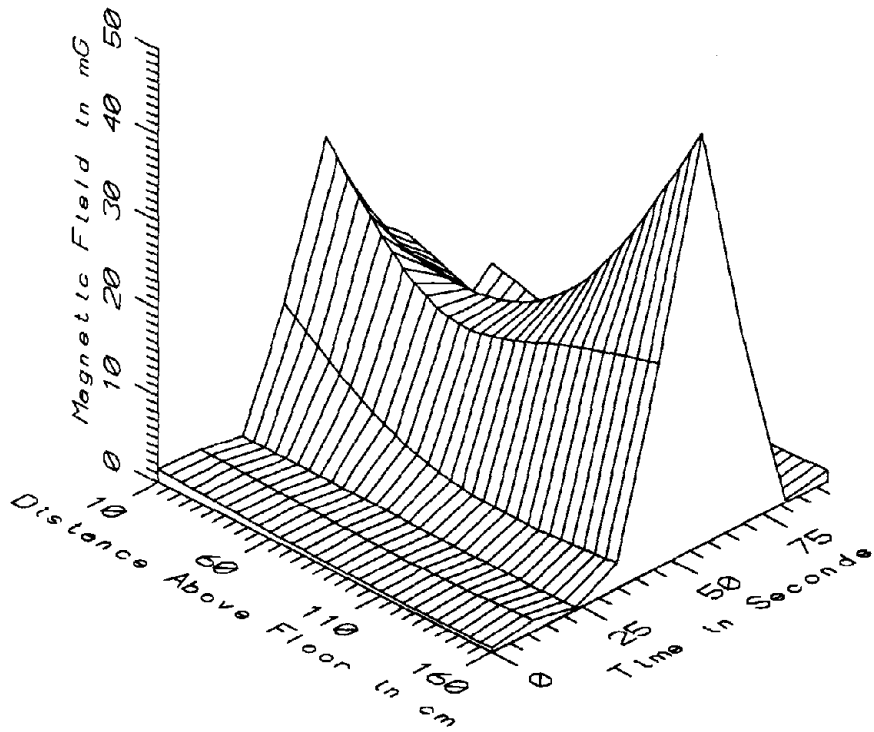

MET026 - IN FRONT OF OPERATOR'S SEAT, CAR 2XXX - LOW FREQ, 5-45Hz

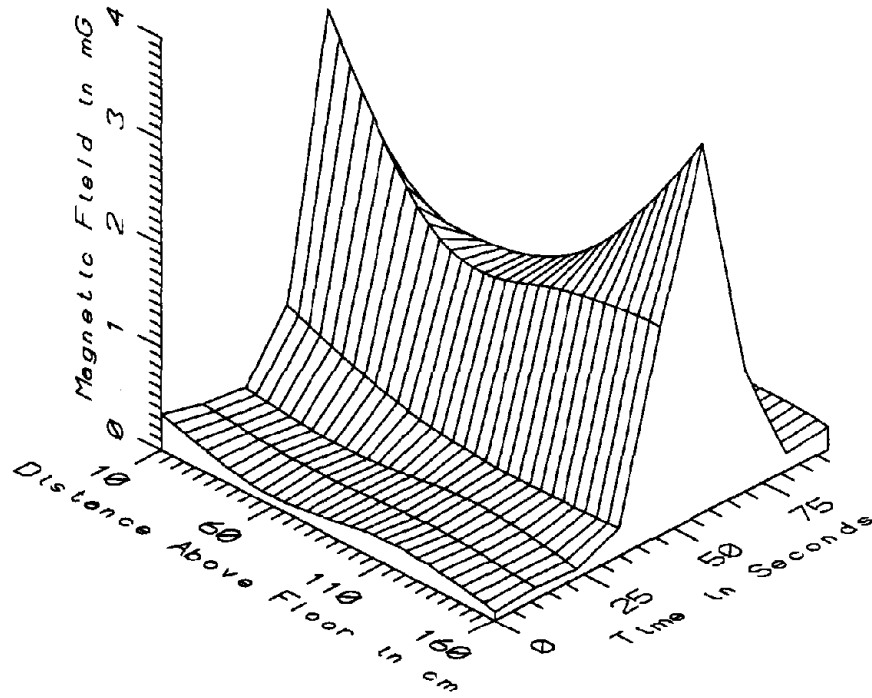

MET026 - IN FRONT OF OPERATOR'S SEAT, CAR 2XXX - POWER FREQ, 50-60Hz

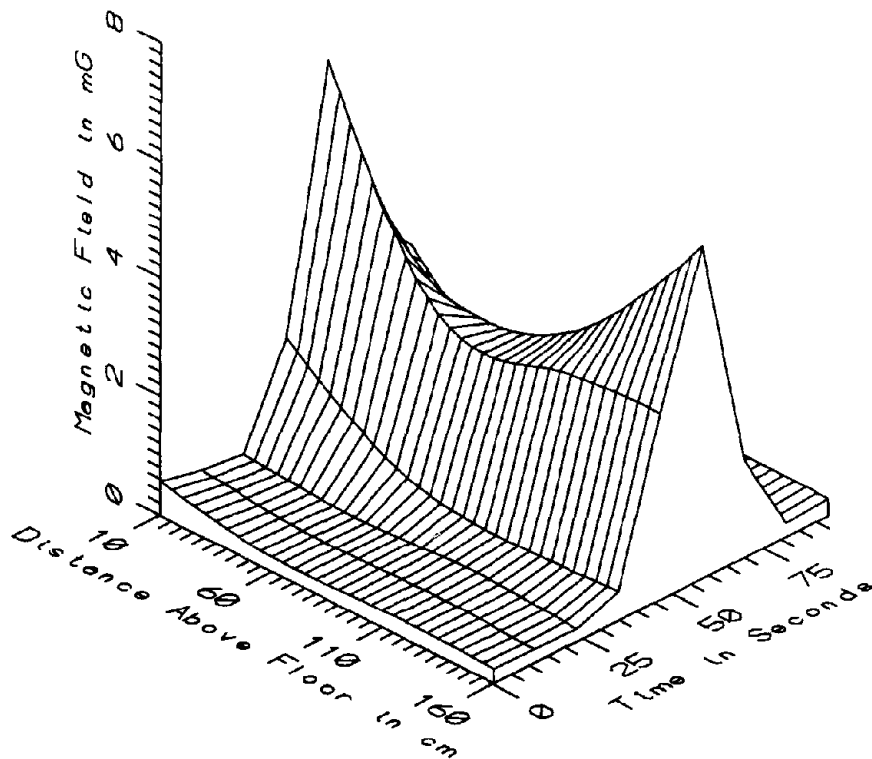

MET026 - IN FRONT OF OPERATOR'S SEAT, CAR 2XXX - POWER HARM, 65-300Hz

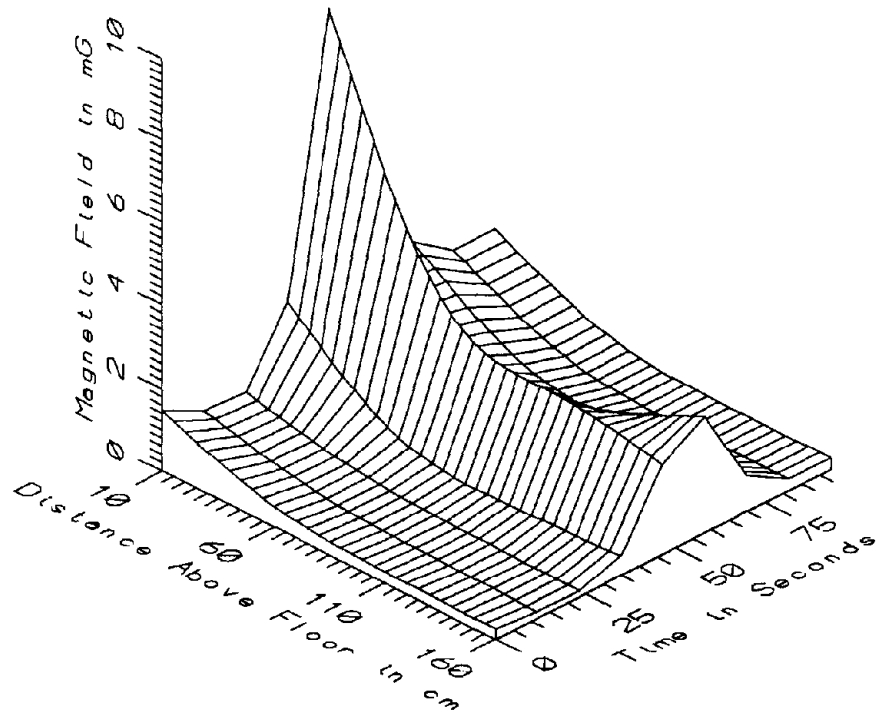

MET026 - IN FRONT OF OPERATOR'S SEAT, CAR 2XXX - HIGH FREQ, 305-2560Hz

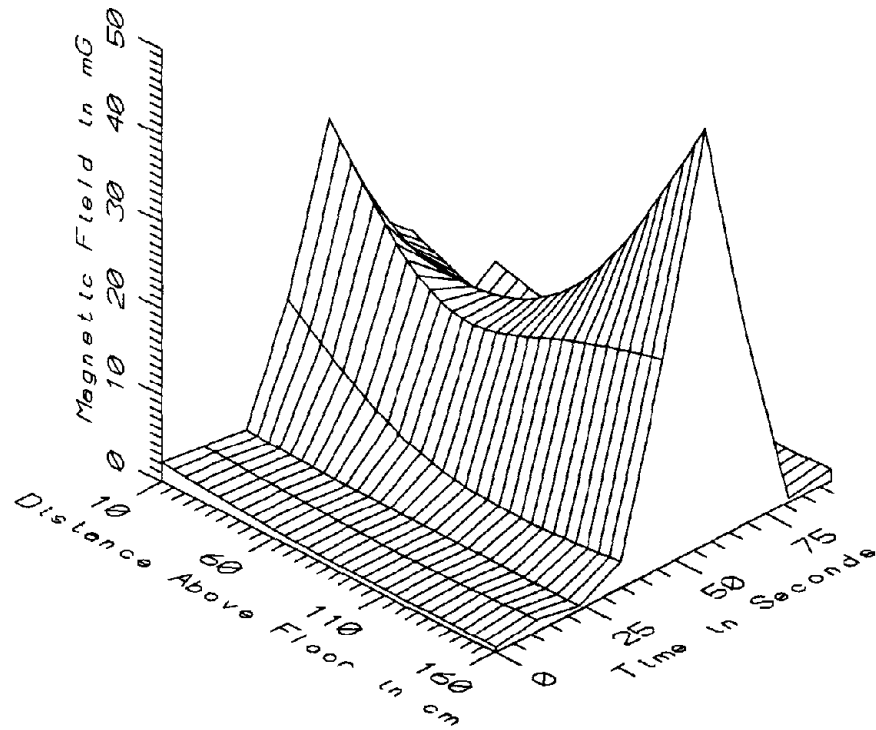

MET026 - IN FRONT OF OPERATOR'S SEAT, CAR 2XXX - ALL FREQ, 5-2560Hz



MET026 - IN FRONT OF OPERATOR'S SEAT IN A 2000 SERIES CAR TOTAL OF 9 SAMPLES						
FREQUENCY BAND	HEIGHT ABOVE FLOOR (cm)	MINIMUM MAGNETIC FIELD (mG)	MAXIMUM MAGNETIC FIELD (mG)	AVERAGE MAGNETIC FIELD (mG)	STANDARD DEVIATION (mG)	COEFFICIENT OF VARIATION (%)
STATIC	10	1110.41	2585.42	1554.05	487.82	31.39
	60	748.75	1781.85	1017.48	385.09	37.85
	110	408.40	1542.02	708.69	421.52	59.48
	160	192.13	1437.13	611.32	408.53	66.83
5-45Hz LOW FREQ	10	0.45	30.01	9.47	10.12	106.94
	60	0.32	16.87	5.83	6.72	115.33
	110	0.15	24.51	6.75	9.49	140.59
	160	0.31	47.40	11.03	16.52	149.80
50-60Hz PWR FREQ	10	0.20	3.45	0.88	1.06	119.94
	60	0.10	1.78	0.55	0.66	118.99
	110	0.18	2.03	0.68	0.74	109.73
	160	0.08	3.57	0.86	1.21	141.49
65-300Hz PWR HARM	10	0.31	6.27	1.75	1.99	113.82
	60	0.20	2.90	0.90	1.05	116.87
	110	0.23	3.31	1.01	1.22	121.45
	160	0.22	5.60	1.35	1.88	139.51
305-2560Hz HIGH FREQ	10	0.90	9.17	2.58	2.54	98.47
	60	0.35	3.48	0.96	0.99	103.27
	110	0.18	2.59	0.72	0.84	117.03
	160	0.14	2.85	0.84	0.99	118.54
5-2560Hz ALL FREQ	10	1.07	32.19	10.18	10.49	103.12
	60	0.53	17.56	6.06	6.86	113.14
	110	0.45	24.87	6.97	9.58	137.35
	160	0.41	47.94	11.21	16.67	148.68



APPENDIX X

DATASET MET027  
CENTER OF AISLE, REAR OF A 2000 SERIES CAR

Measurement Setup Code:      Staff:      5      Reference: -  
   Drawing:    A-1

Vehicle Status:                Traveling on the Green Line

Measurement Date:             May 19, 1992

Measurement Time:             Start:      15:33:35  
   End:        15:35:25

Number of Samples:            11

Programmed Sample Interval:   5 sec

Actual Sample Interval:       11.0 sec

Frequency Spectrum Parameters

<u>Probe Type:</u>	<u>Wideband</u>	<u>Static</u>
Maximum Frequency (Hz)	2560	100
Minimum Frequency (Hz)	5	0
Spectral Bandwidth (Hz)	5	1

Missing Data: No reference probe

Saturated Data - Wideband:	<u>Sensor</u>	<u>Sample</u>	<u>Time (sec)</u>
	10cm	5	44
	110cm	8	77
	160cm	8	77

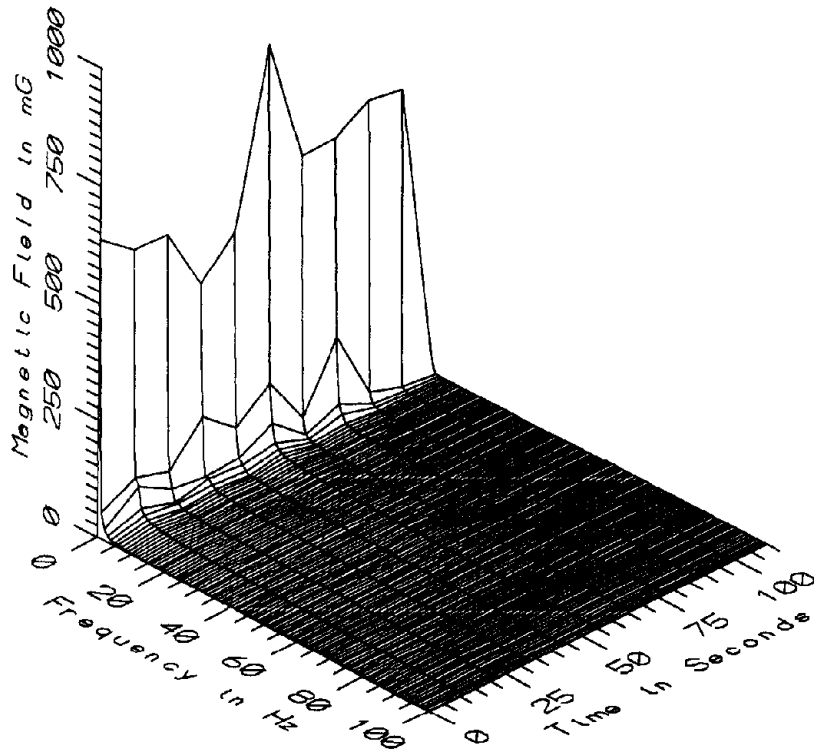

MET027 - 160cm ABOVE FLOOR, CENTER OF AISLE, REAR OF CAR 2XXX

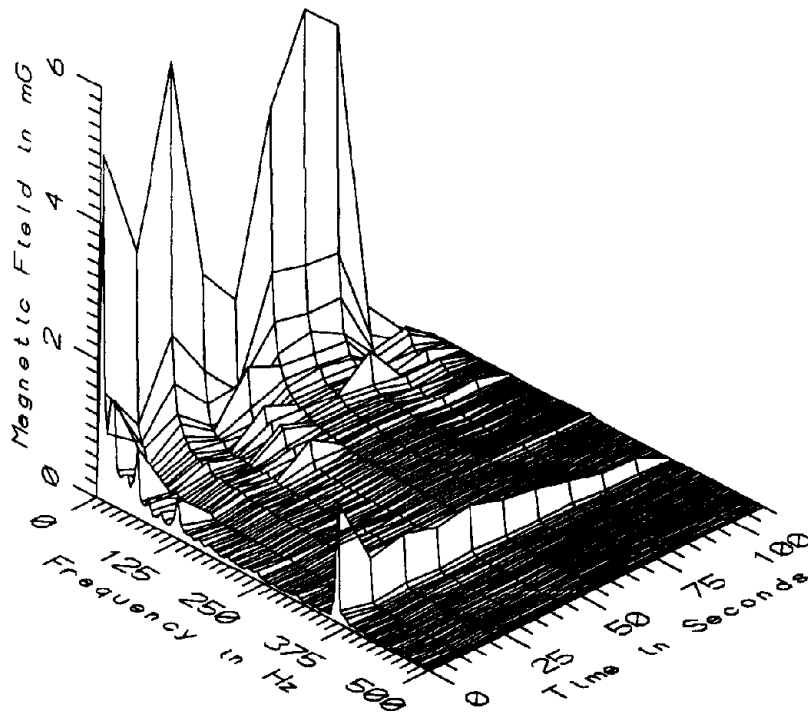

MET027 - 160cm ABOVE FLOOR, CENTER OF AISLE, REAR OF CAR 2XXX

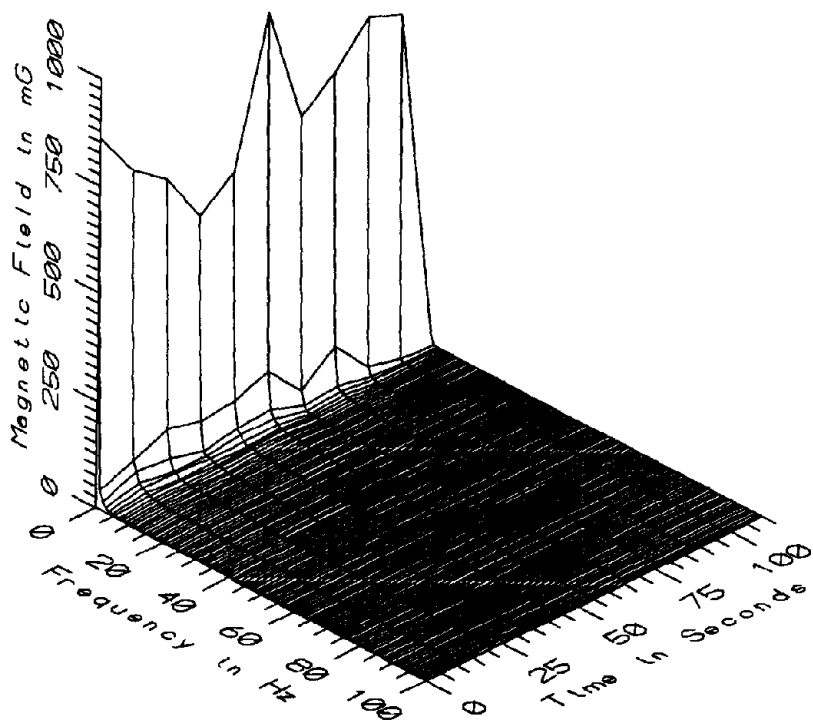

MET027 - 110cm ABOVE FLOOR, CENTER OF AISLE, REAR OF CAR 2XXX

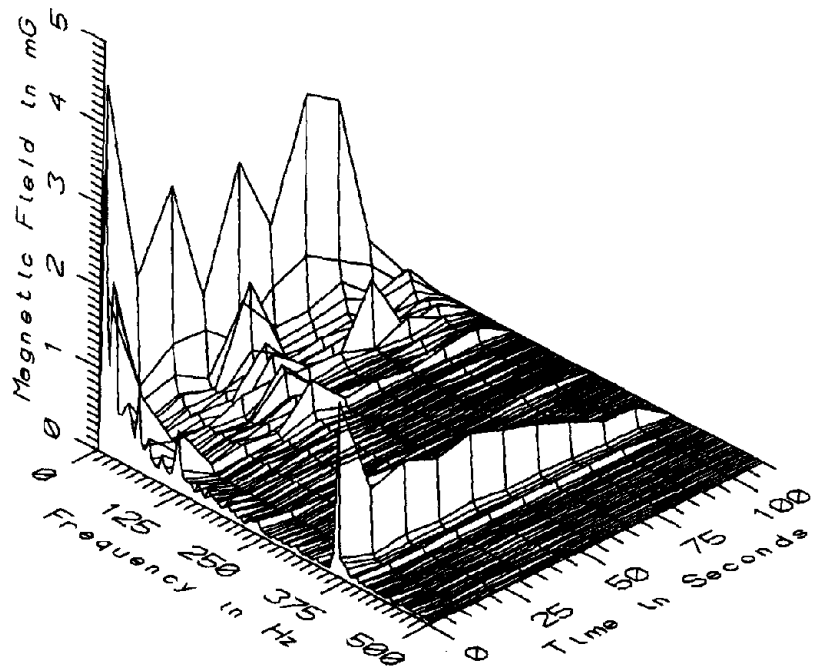

MET027 - 110cm ABOVE FLOOR, CENTER OF AISLE, REAR OF CAR 2XXX

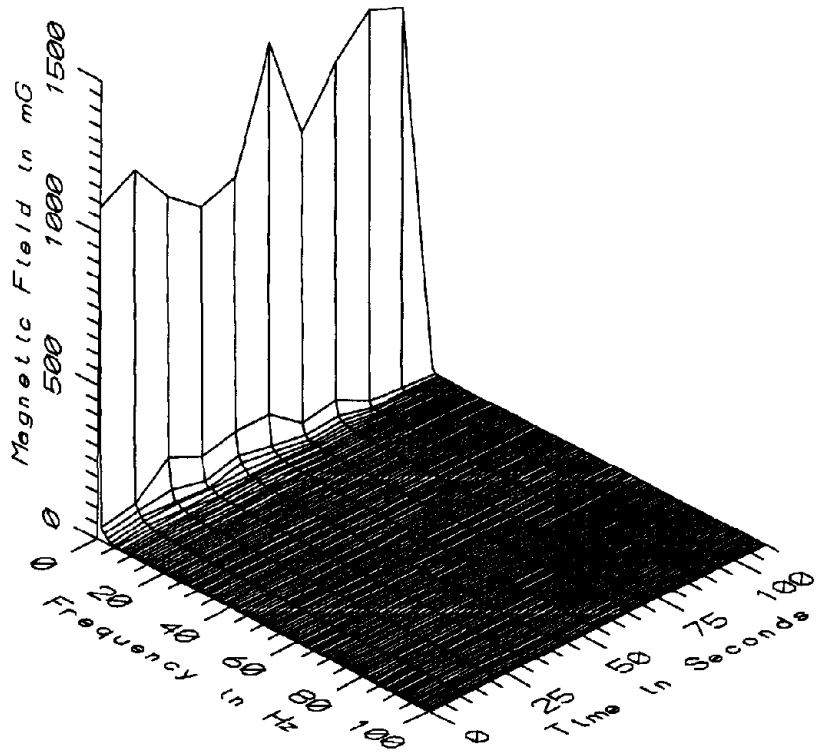

MET027 - 60cm ABOVE FLOOR, CENTER OF AISLE, REAR OF CAR 2XXX

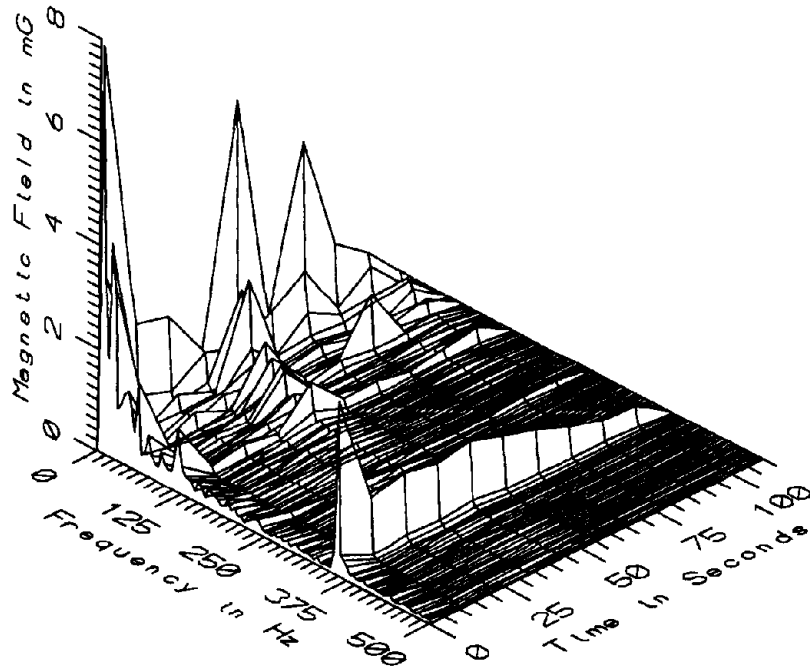

MET027 - 60cm ABOVE FLOOR, CENTER OF AISLE, REAR OF CAR 2XXX

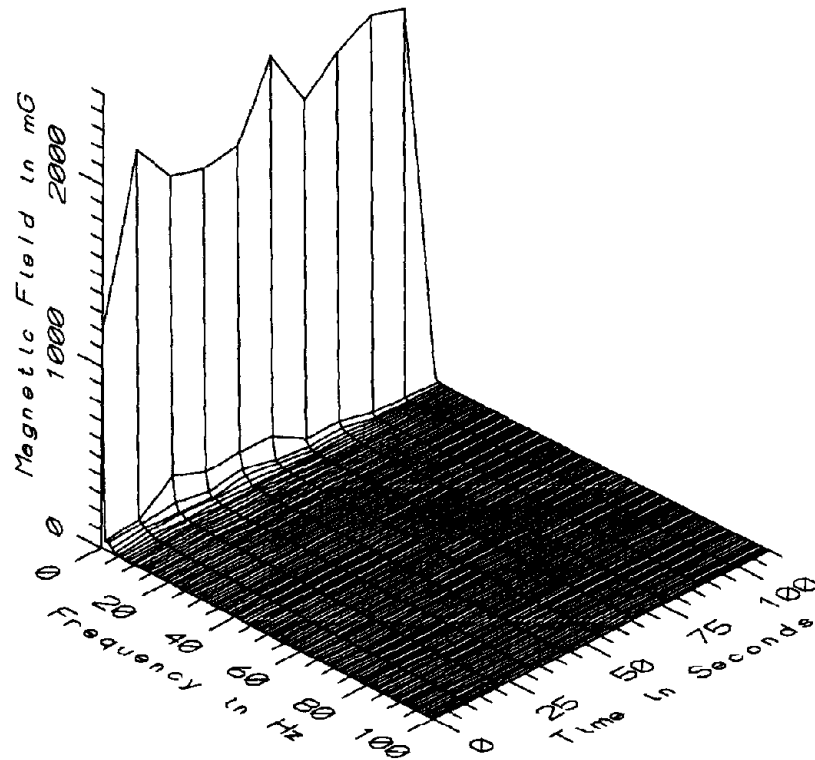

MET027 - 10cm ABOVE FLOOR, CENTER OF AISLE, REAR OF CAR 2XXX

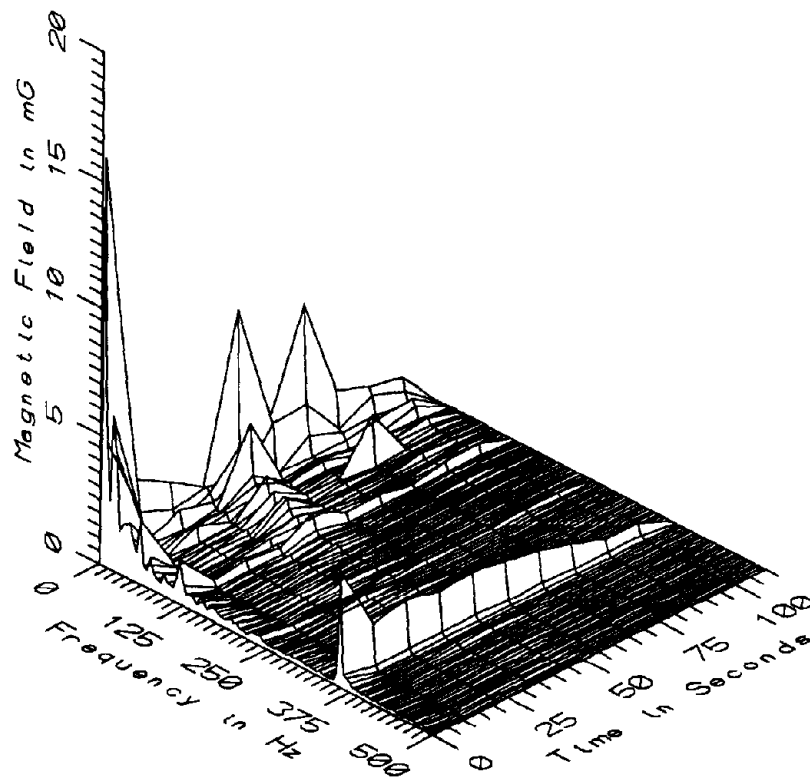

MET027 - 10cm ABOVE FLOOR, CENTER OF AISLE, REAR OF CAR 2XXX

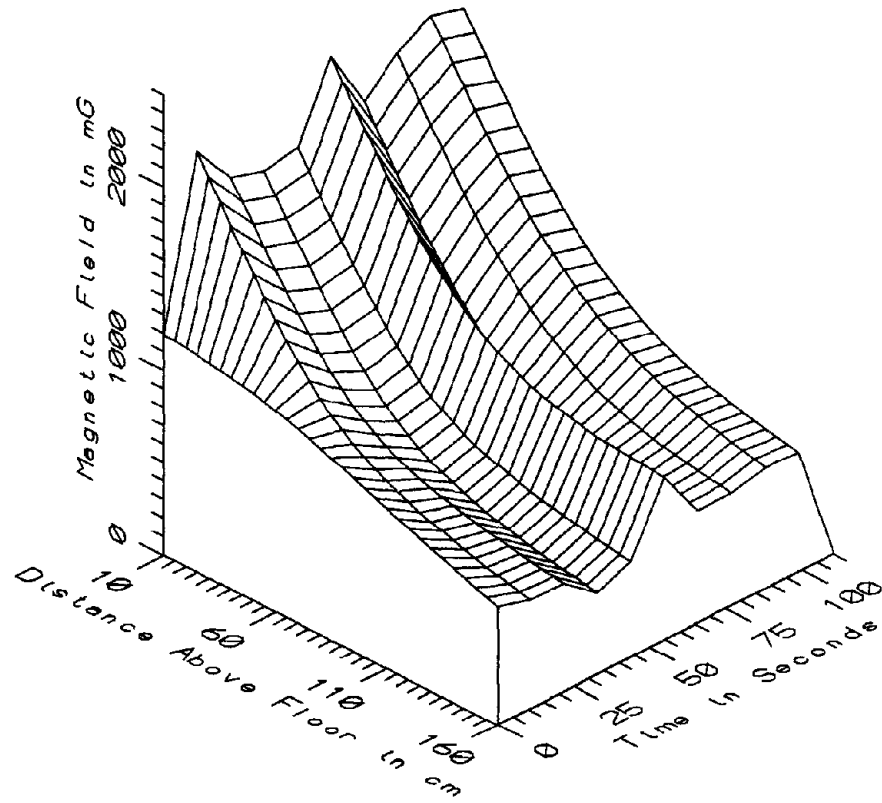

MET027 - CENTER OF AISLE, REAR OF CAR 2XXX - STATIC

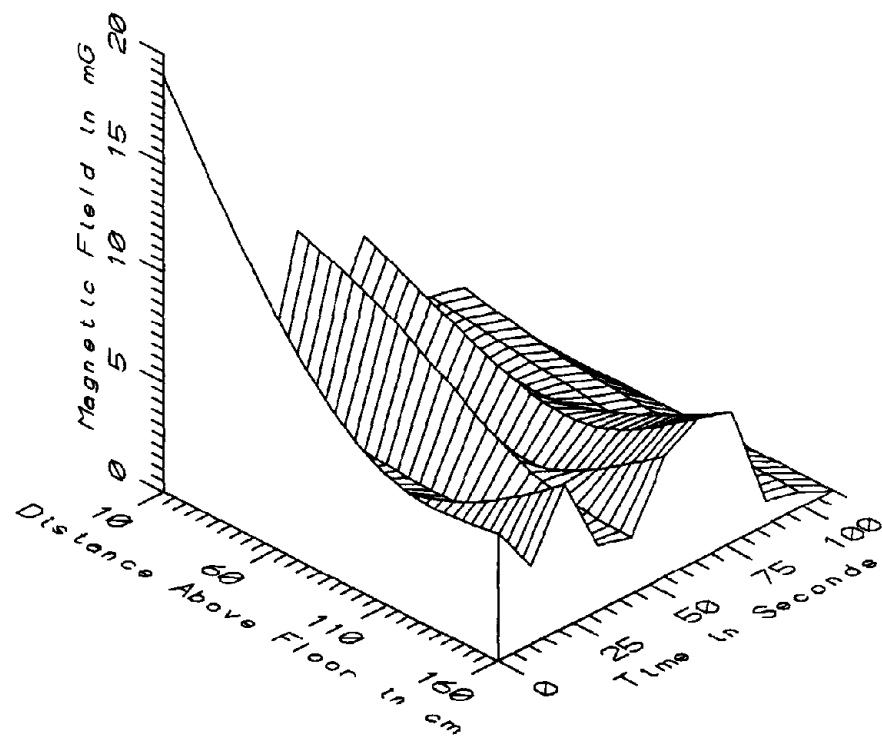

MET027 - CENTER OF AISLE, REAR OF CAR 2XXX - LOW FREQ, 5-45Hz



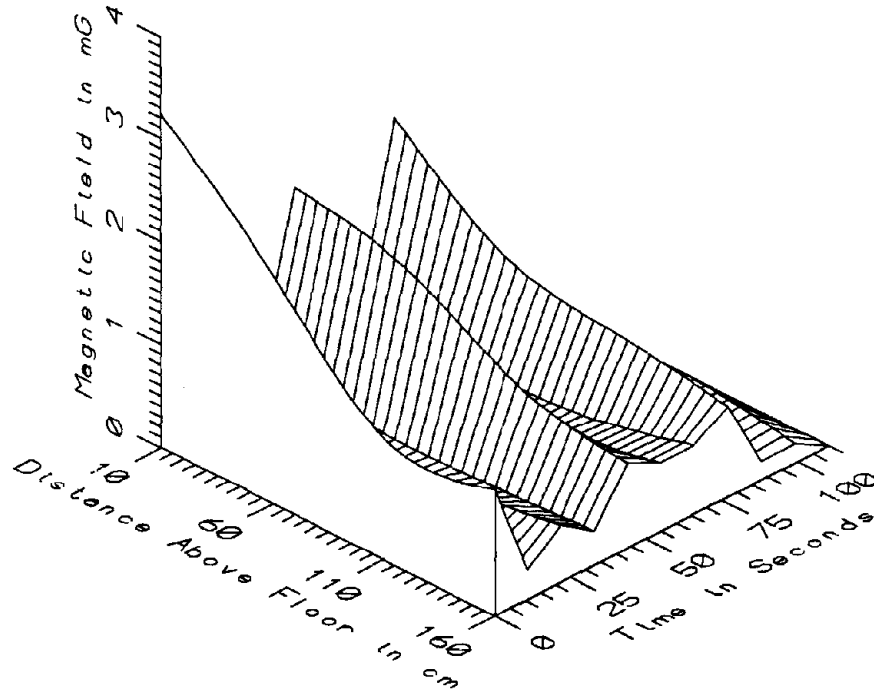

MET027 - CENTER OF AISLE, REAR OF CAR 2XXX - POWER FREQ, 50-60Hz

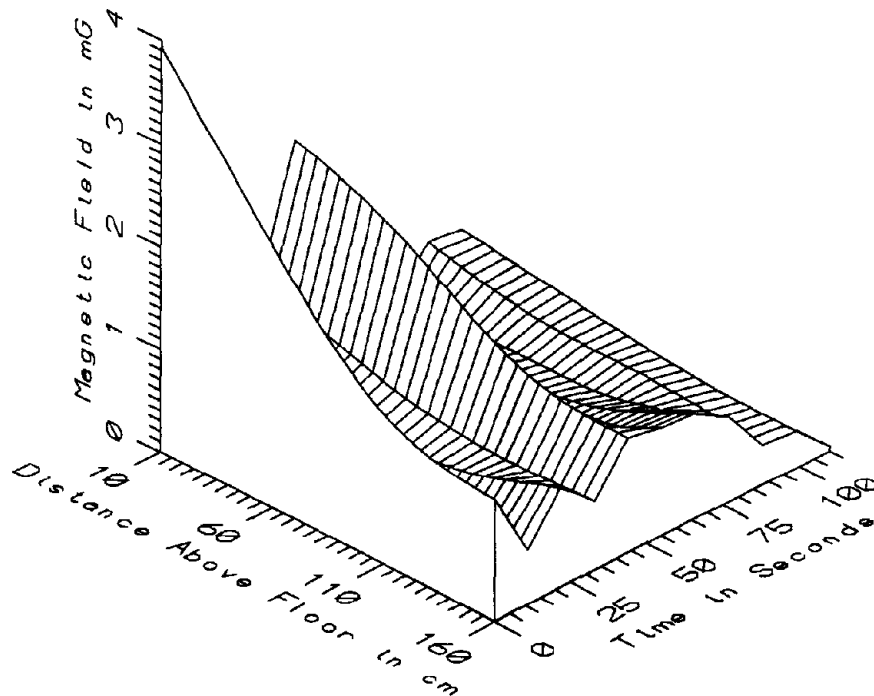

MET027 - CENTER OF AISLE, REAR OF CAR 2XXX - POWER HARM, 65-300Hz

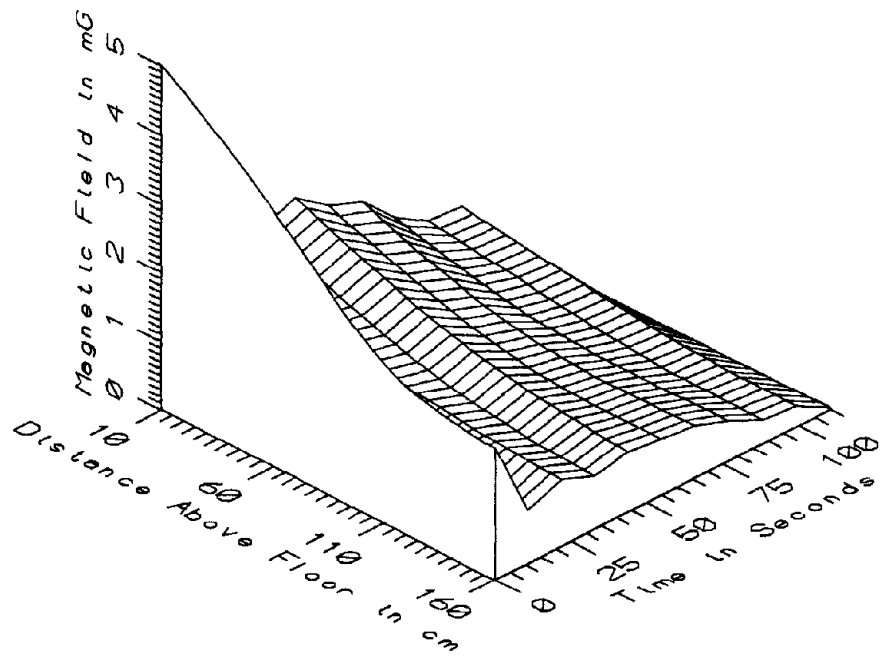

MET027 - CENTER OF AISLE, REAR OF CAR 2XXX - HIGH FREQ, 305-2560Hz

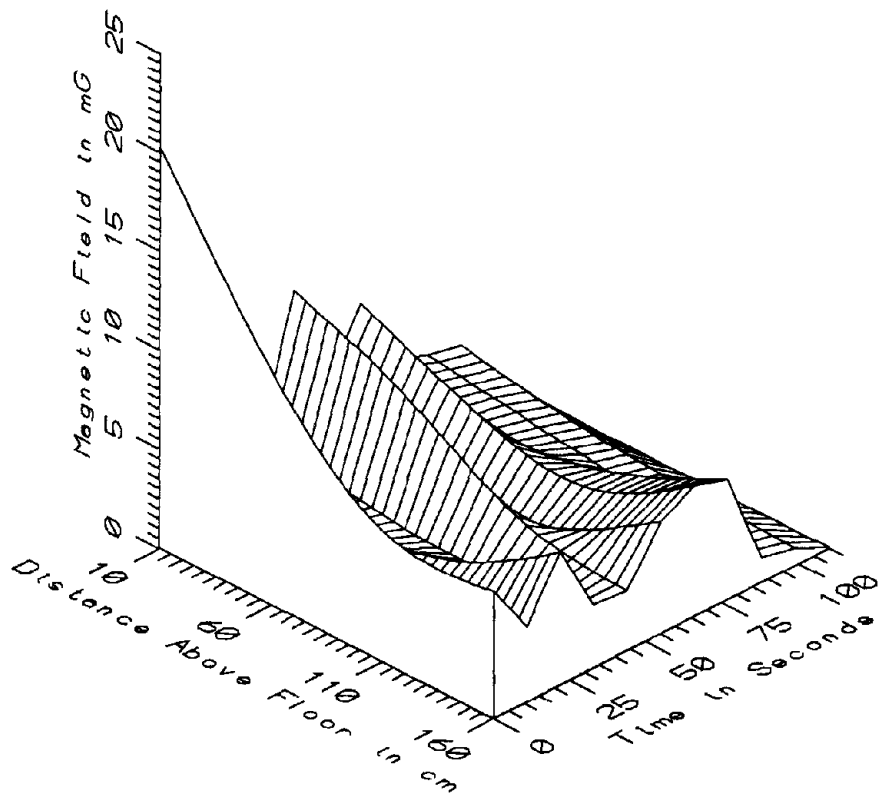

MET027 - CENTER OF AISLE, REAR OF CAR 2XXX - ALL FREQ, 5-2560Hz

MET027- CENTER OF AISLE, REAR OF A 2000 SERIES CAR		TOTAL OF 11 SAMPLES				
FREQUENCY BAND	HEIGHT ABOVE FLOOR (cm)	MINIMUM MAGNETIC FIELD (mG)	MAXIMUM MAGNETIC FIELD (mG)	AVERAGE MAGNETIC FIELD (mG)	STANDARD DEVIATION (mG)	COEFFICIENT OF VARIATION (%)
STATIC	10	14.06	2249.66	1765.59	649.05	36.76
	60	18.57	1351.63	1023.53	361.22	35.29
	110	21.86	965.25	686.67	247.50	36.04
	160	19.92	873.61	557.55	207.87	37.28
5-45Hz	10	0.01	18.95	4.93	5.23	105.98
LOW FREQ	60	0.00	10.66	3.22	3.01	93.33
	110	0.02	5.91	2.53	1.59	62.94
	160	0.00	6.51	3.75	2.43	64.80
50-60Hz	10	0.00	3.23	0.91	1.01	111.18
PWR FREQ	60	0.00	2.22	0.63	0.72	113.85
	110	0.00	1.18	0.52	0.38	74.25
	160	0.00	1.22	0.52	0.37	69.92
65-300Hz	10	0.01	3.94	1.12	1.11	99.12
PWR HARM	60	0.00	2.56	0.81	0.75	92.01
	110	0.01	1.46	0.62	0.41	65.40
	160	0.05	1.16	0.74	0.37	49.81
305-2560Hz	10	0.04	5.00	1.74	1.28	73.15
HIGH FREQ	60	0.02	3.74	1.20	0.95	79.42
	110	0.03	2.31	0.84	0.59	70.14
	160	0.03	1.90	0.73	0.48	64.99
5-2560Hz	10	0.04	20.25	5.54	5.47	98.65
ALL FREQ	60	0.02	11.79	3.65	3.25	89.17
	110	0.04	6.62	2.81	1.74	62.14
	160	0.06	6.68	3.96	2.47	62.37



APPENDIX Y

DATASET MET028  
CENTER OF AISLE, CENTER OF A 2000 SERIES CAR

Measurement Setup Code:        Staff:    1     Reference: -  
   Drawing: A-1

Vehicle Status:                    Traveling on the Green Line

Measurement Date:                May 19, 1992

Measurement Time:                Start:    15:37:44  
   End:      15:40:33

Number of Samples:                24

Programmed Sample Interval:    5 sec

Actual Sample Interval:         7.3 sec

Frequency Spectrum Parameters

<u>Probe Type:</u>	<u>Wideband</u>	<u>Static</u>
Maximum Frequency (Hz)	2560	100
Minimum Frequency (Hz)	5	0
Spectral Bandwidth (Hz)	5	1

Missing Data: No reference probe

Saturated Data - Wideband:	<u>Sensor</u>	<u>Sample</u>	<u>Time (sec)</u>
	10cm	19	131
	10cm	21	146
	60cm	19	131
	110cm	19	131
	160cm	19	131

Saturated Data - Static:	<u>Sensor</u>	<u>Sample</u>	<u>Time (sec)</u>
	10cm	19	131

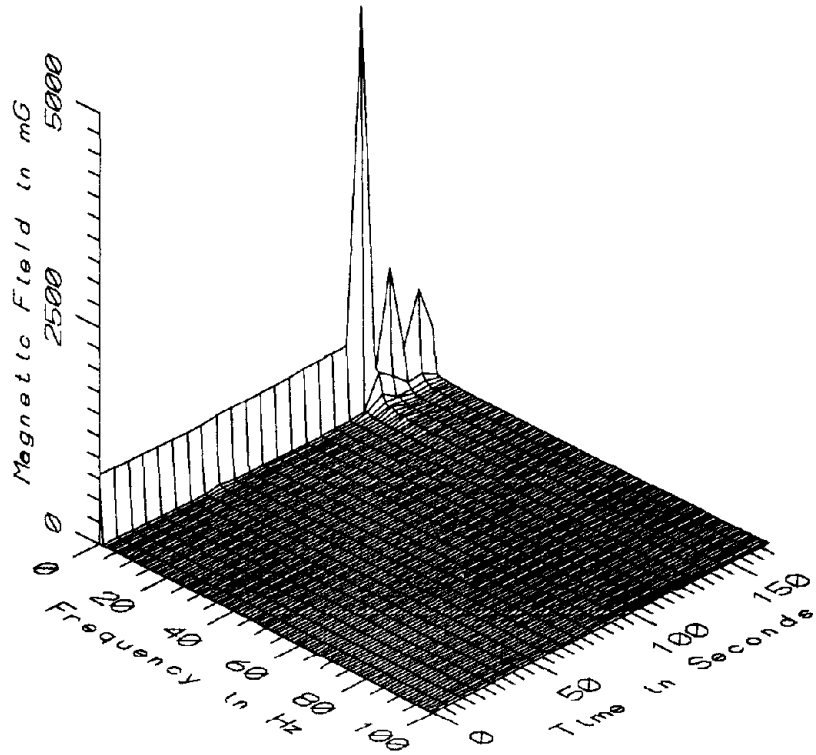

MET028 - 10cm ABOVE FLOOR, CENTER OF AISLE, CENTER OF CAR 2XXX

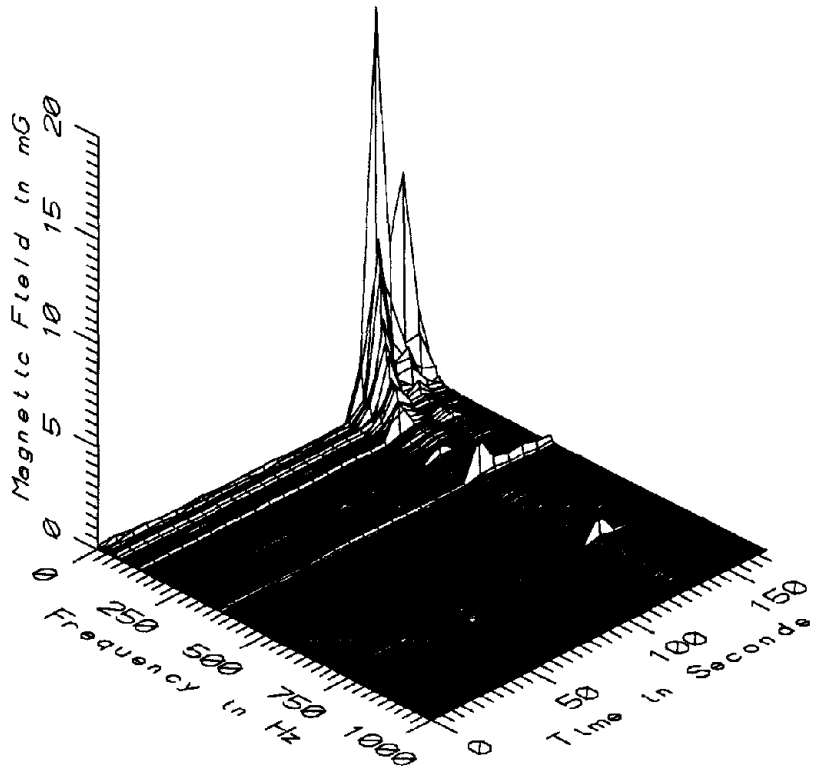

MET028 - 10cm ABOVE FLOOR, CENTER OF AISLE, CENTER OF CAR 2XXX

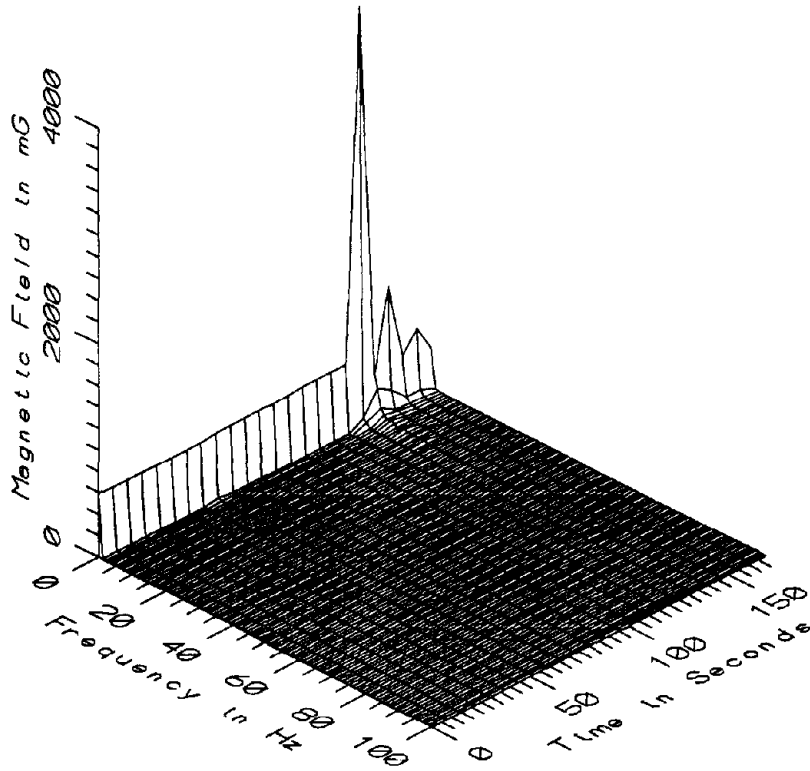

MET028 - 60cm ABOVE FLOOR, CENTER OF AISLE, CENTER OF CAR 2XXX

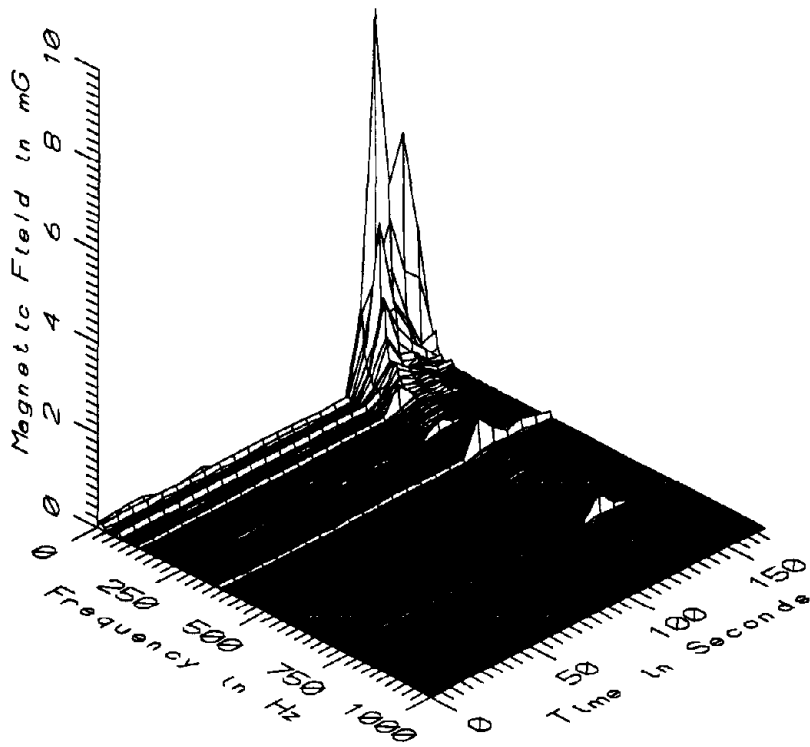

MET028 - 60cm ABOVE FLOOR, CENTER OF AISLE, CENTER OF CAR 2XXX

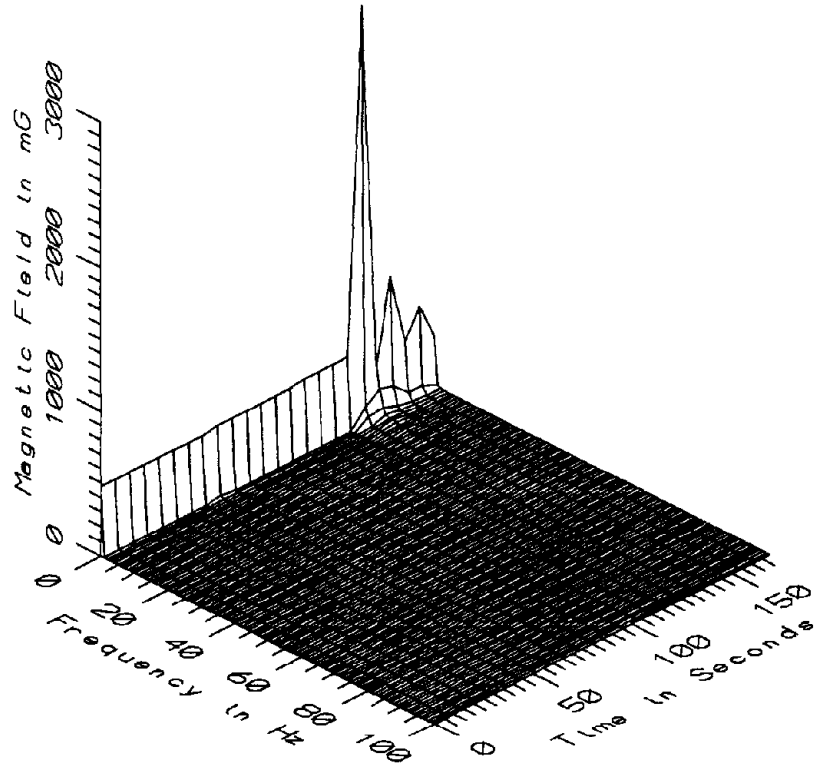

MET028 - 110cm ABOVE FLOOR, CENTER OF AISLE, CENTER OF CAR 2XXX

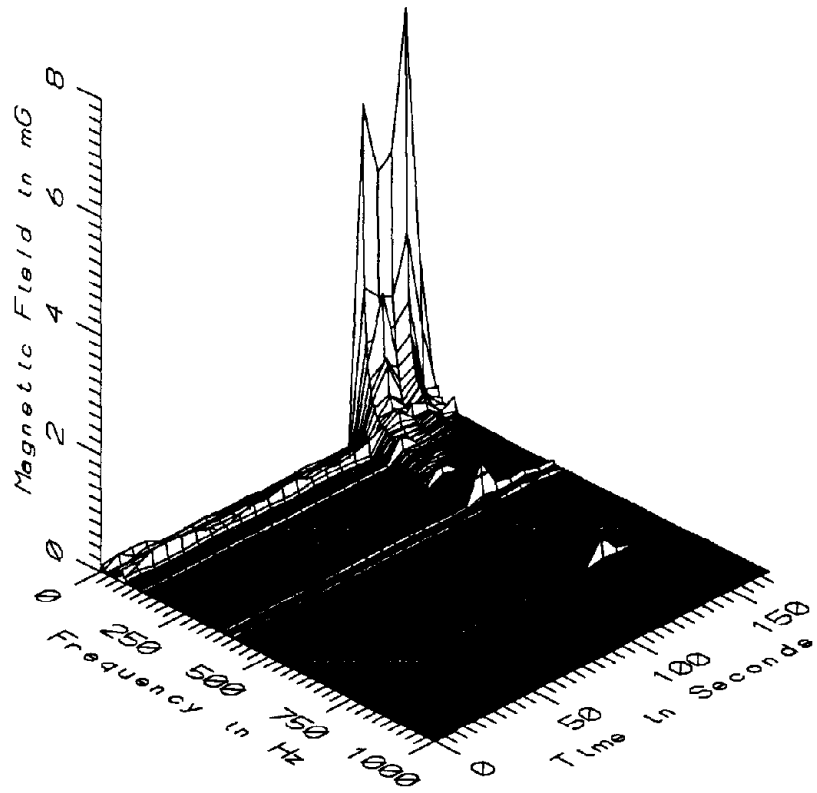

MET028 - 110cm ABOVE FLOOR, CENTER OF AISLE, CENTER OF CAR 2XXX



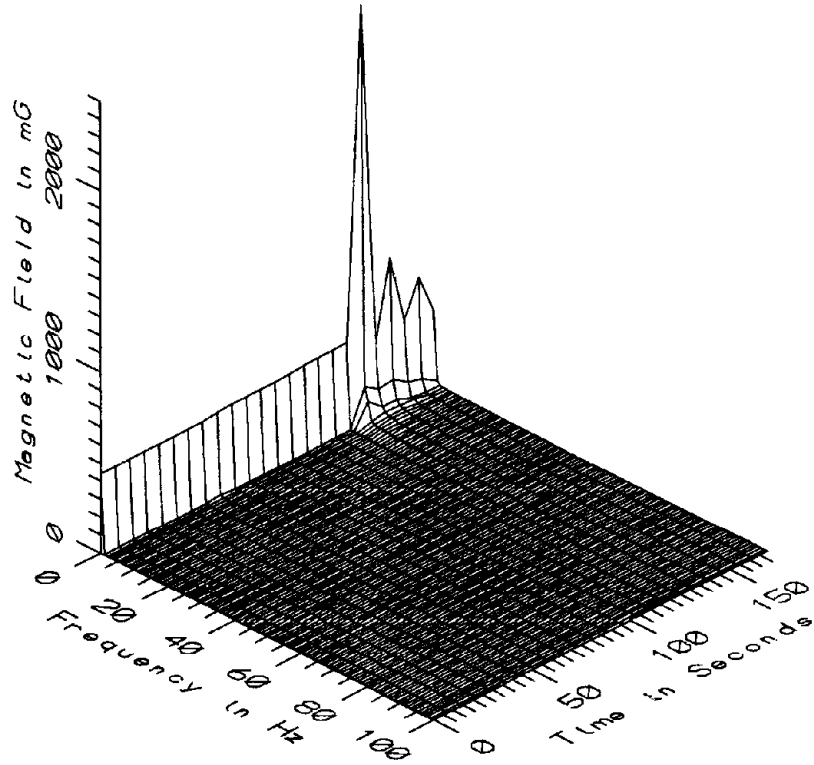

MET028 - 160cm ABOVE FLOOR, CENTER OF AISLE, CENTER OF CAR 2XXX

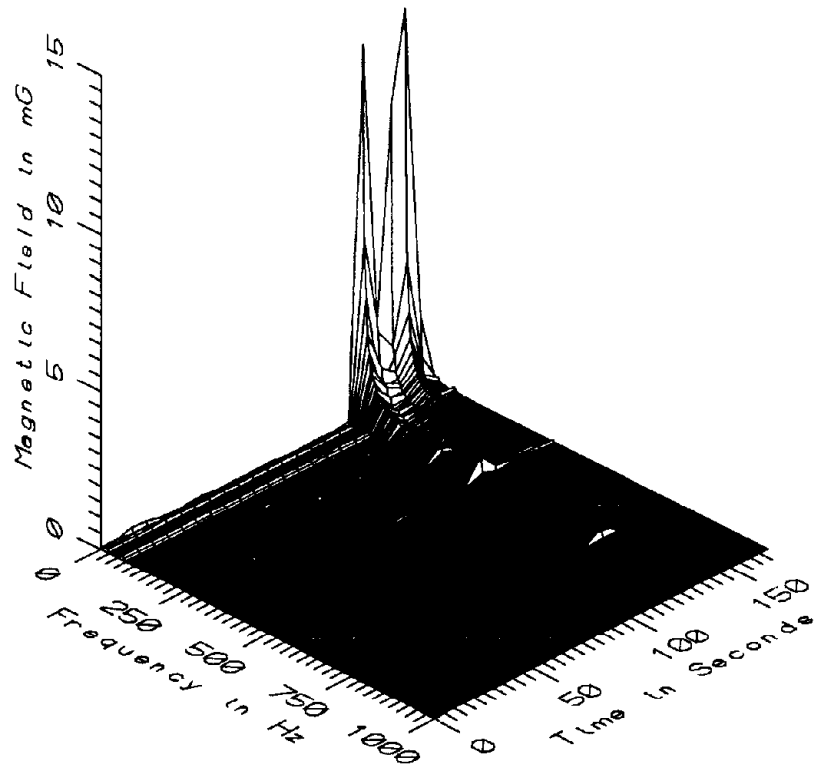

MET028 - 160cm ABOVE FLOOR, CENTER OF AISLE, CENTER OF CAR 2XXX

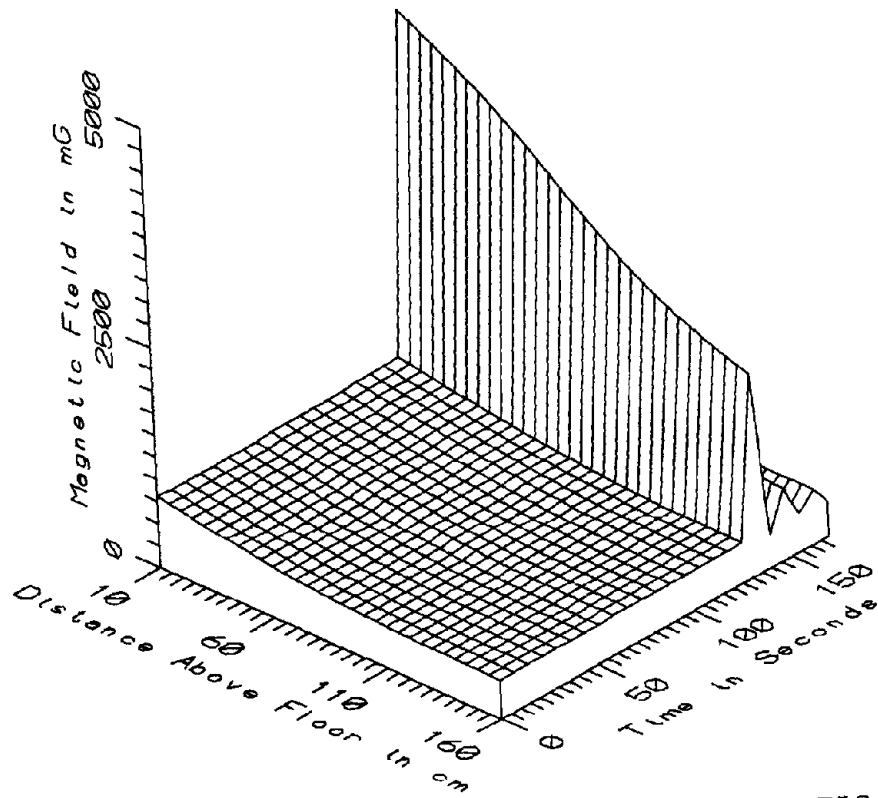

MET028 - CENTER OF AISLE, CENTER OF CAR 2XXX - STATIC

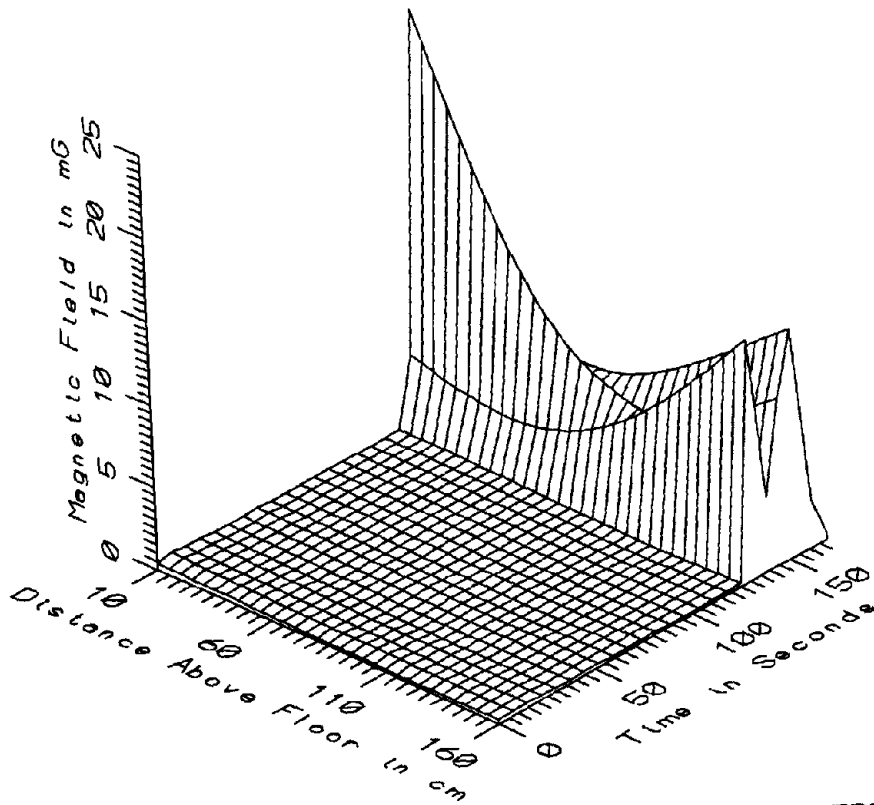

MET028 - CENTER OF AISLE, CENTER OF CAR 2XXX - LOW FREQ. 5-45Hz

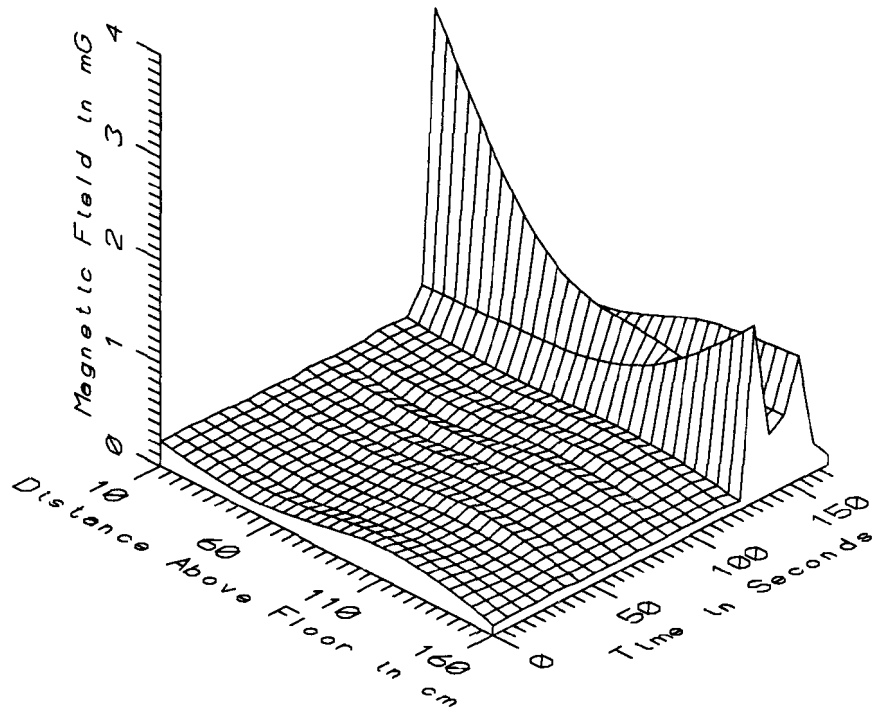

MET028 - CENTER OF AISLE, CENTER OF CAR 2XXX - POWER FREQ, 50-60Hz

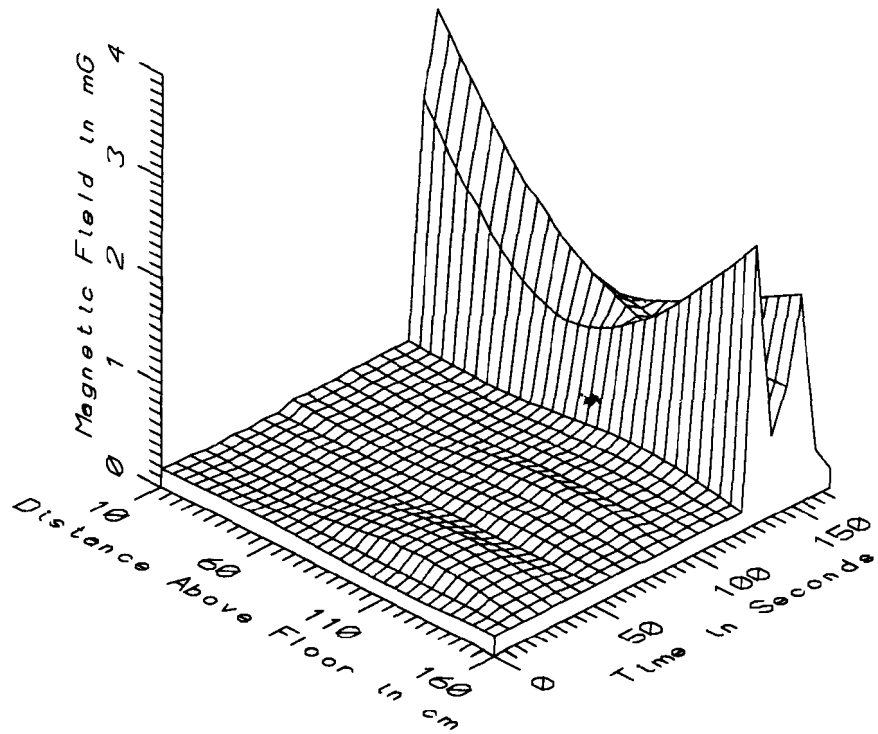

MET028 - CENTER OF AISLE, CENTER OF CAR 2XXX - POWER HARM, 65-300Hz

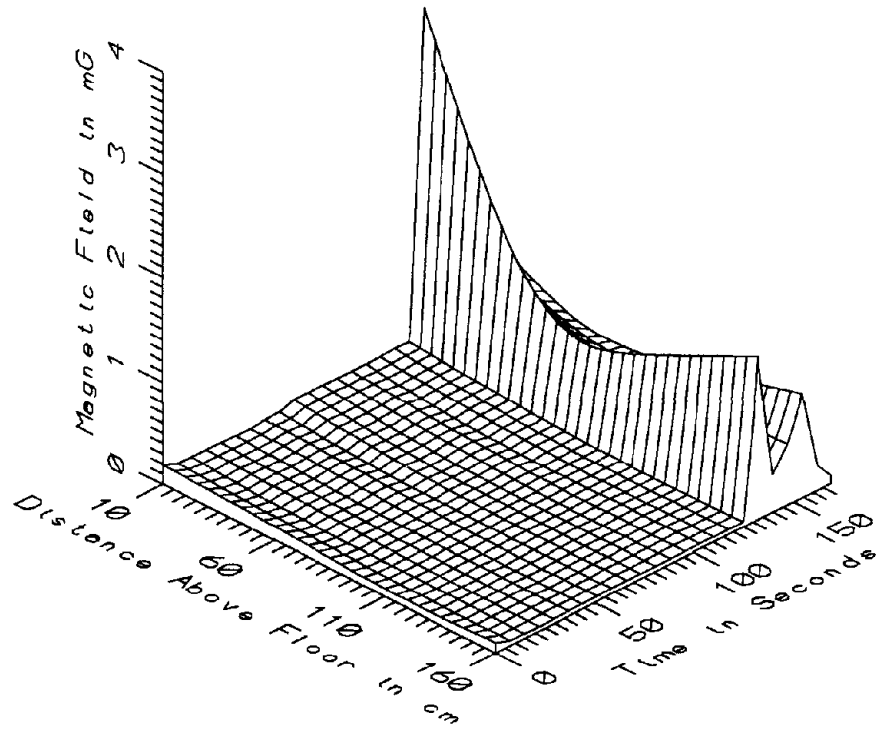

MET028 - CENTER OF AISLE, CENTER OF CAR 2XXX - HIGH FREQ, 305-2560Hz

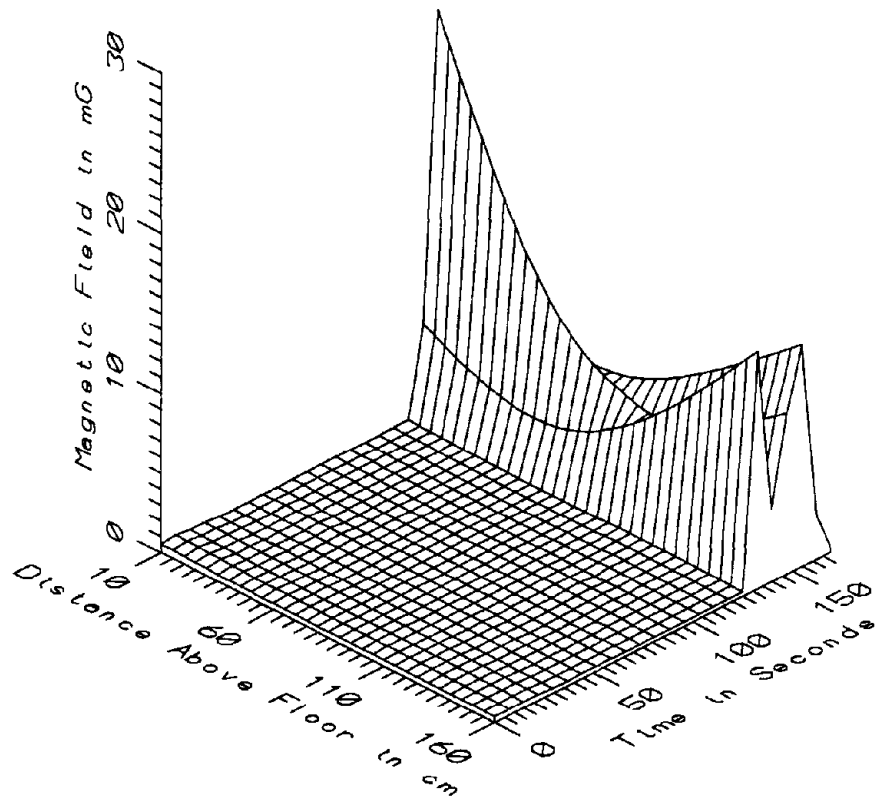

MET028 - CENTER OF AISLE, CENTER OF CAR 2XXX - ALL FREQ, 5-2560Hz

MET028 - CENTER OF A 2000 SERIES CAR - ALL SAMPLES		TOTAL OF 24 SAMPLES				
FREQUENCY BAND	HEIGHT ABOVE FLOOR (cm)	MINIMUM MAGNETIC FIELD (mG)	MAXIMUM MAGNETIC FIELD (mG)	AVERAGE MAGNETIC FIELD (mG)	STANDARD DEVIATION (mG)	COEFFICIENT OF VARIATION (%)
STATIC	10	415.08	4713.82	971.54	820.88	84.49
	60	370.75	3912.45	744.70	688.41	92.44
	110	357.05	2890.56	596.59	498.98	83.64
	160	382.52	2293.28	545.88	381.60	69.91
5-45Hz	10	0.23	24.73	2.68	5.70	212.20
LOW FREQ	60	0.18	10.45	1.47	2.70	183.26
	110	0.03	8.27	1.36	2.58	190.15
	160	0.18	14.50	2.08	4.29	206.27
50-60Hz	10	0.19	3.09	0.46	0.65	141.64
PWR FREQ	60	0.12	1.27	0.27	0.28	103.81
	110	0.17	1.02	0.34	0.24	71.34
	160	0.09	1.70	0.27	0.40	149.51
65-300Hz	10	0.14	3.29	0.59	0.90	151.52
PWR HARM	60	0.17	1.80	0.39	0.46	118.79
	110	0.16	1.42	0.43	0.40	92.39
	160	0.18	2.68	0.44	0.64	143.64
305-2560Hz	10	0.12	3.35	0.44	0.71	159.99
HIGH FREQ	60	0.06	1.11	0.22	0.29	133.41
	110	0.04	1.06	0.17	0.27	158.25
	160	0.04	1.59	0.20	0.37	184.37
5-2560Hz	10	0.41	25.16	2.91	5.80	198.94
ALL FREQ	60	0.31	10.71	1.61	2.74	170.33
	110	0.32	8.48	1.60	2.56	159.76
	160	0.29	14.93	2.19	4.35	198.74

MET028 - CENTER OF A 2000 SERIES CAR - NOT MOVING		TOTAL OF 18 SAMPLES				
FREQUENCY BAND	HEIGHT ABOVE FLOOR (cm)	MINIMUM MAGNETIC FIELD (mG)	MAXIMUM MAGNETIC FIELD (mG)	AVERAGE MAGNETIC FIELD (mG)	STANDARD DEVIATION (mG)	COEFFICIENT OF VARIATION (%)
STATIC	10	786.70	843.74	809.20	19.36	2.39
	60	584.86	639.02	607.25	19.71	3.25
	110	471.65	508.49	487.62	14.21	2.91
	160	440.57	469.90	452.60	10.54	2.33
5-45Hz LOW FREQ	10	0.23	0.58	0.33	0.08	24.25
	60	0.18	0.34	0.22	0.05	20.74
	110	0.03	0.28	0.11	0.06	58.36
	160	0.18	0.31	0.23	0.04	16.72
50-60Hz PWR FREQ	10	0.21	0.25	0.23	0.01	4.43
	60	0.12	0.19	0.16	0.02	13.31
	110	0.20	0.31	0.24	0.03	11.08
	160	0.09	0.12	0.10	0.01	6.99
65-300Hz PWR HARM	10	0.14	0.21	0.18	0.02	13.15
	60	0.17	0.20	0.18	0.01	4.15
	110	0.16	0.32	0.25	0.05	20.88
	160	0.18	0.19	0.19	0.00	1.72
305-2560Hz HIGH FREQ	10	0.12	0.19	0.15	0.03	16.59
	60	0.06	0.14	0.08	0.02	23.21
	110	0.04	0.07	0.05	0.01	15.56
	160	0.04	0.10	0.05	0.01	23.00
5-2560Hz ALL FREQ	10	0.41	0.66	0.47	0.06	12.42
	60	0.31	0.43	0.34	0.03	9.35
	110	0.32	0.45	0.37	0.04	10.23
	160	0.29	0.38	0.32	0.03	9.12

MET028 - CENTER OF A 2000 SERIES CAR - IN MOTION		TOTAL OF 6 SAMPLES				
FREQUENCY BAND	HEIGHT ABOVE FLOOR (cm)	MINIMUM MAGNETIC FIELD (mG)	MAXIMUM MAGNETIC FIELD (mG)	AVERAGE MAGNETIC FIELD (mG)	STANDARD DEVIATION (mG)	COEFFICIENT OF VARIATION (%)
STATIC	10	415.08	4713.82	1458.56	1648.91	113.05
	60	370.75	3912.45	1157.03	1380.80	119.34
	110	357.05	2890.56	923.47	986.74	106.85
	160	382.52	2293.28	825.69	737.70	89.34
5-45HZ	10	1.57	24.73	9.74	8.33	85.55
LOW FREQ	60	1.02	10.45	5.24	3.31	63.13
	110	0.53	8.27	5.11	2.84	55.55
	160	0.40	14.50	7.64	5.94	77.75
50-60HZ	10	0.19	3.09	1.14	1.08	95.07
PWR FREQ	60	0.14	1.27	0.59	0.42	70.12
	110	0.17	1.02	0.65	0.35	53.73
	160	0.11	1.70	0.76	0.59	77.74
65-300HZ	10	0.38	3.29	1.83	1.11	60.92
PWR HARM	60	0.29	1.80	1.02	0.59	58.06
	110	0.33	1.42	0.99	0.50	50.47
	160	0.19	2.68	1.21	0.96	78.96
305-2560HZ	10	0.44	3.35	1.31	1.06	80.70
HIGH FREQ	60	0.18	1.11	0.63	0.35	56.04
	110	0.09	1.06	0.54	0.35	65.77
	160	0.08	1.59	0.65	0.56	86.41
5-2560HZ	10	1.68	25.16	10.24	8.28	80.89
ALL FREQ	60	1.09	10.71	5.43	3.36	61.81
	110	0.65	8.48	5.28	2.90	54.83
	160	0.46	14.93	7.81	6.06	77.57





APPENDIX Z

DATASET MET029  
AXIAL PROFILE IN CENTER OF A 2000 SERIES CAR

Measurement Setup Code:        Staff:    2     Reference: -  
   Drawing: A-1

Vehicle Status:                Traveling on the Green Line

Measurement Date:              May 19, 1992

Measurement Time:              Start:     15:41:09  
   End:        15:42:09

Number of Samples:              7

Programmed Sample Interval:    5 sec

Actual Sample Interval:        10.0 sec

Frequency Spectrum Parameters

<u>Probe Type:</u>	<u>Wideband</u>	<u>Static</u>
Maximum Frequency (Hz)	2560	100
Minimum Frequency (Hz)	5	0
Spectral Bandwidth (Hz)	5	1

Missing Data: No reference probe

Saturated Data - Wideband:	<u>Sensor</u> 60cm	<u>Sample</u> 6	<u>Time (sec)</u> 50
----------------------------	-----------------------	--------------------	-------------------------

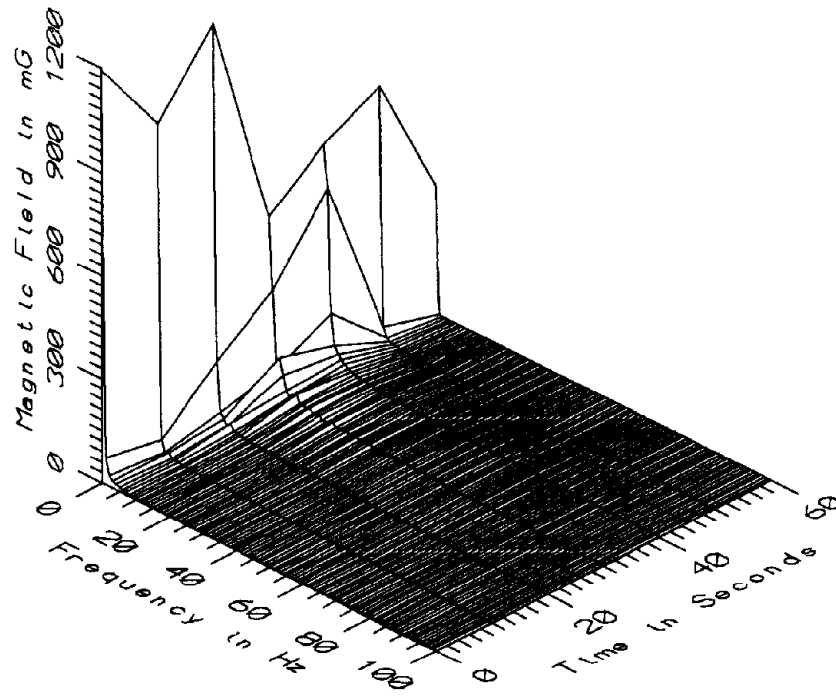

MET029 - -75cm FROM CENTERLINE OF MID DOORS ALONG AXIS OF CAR 2XXX

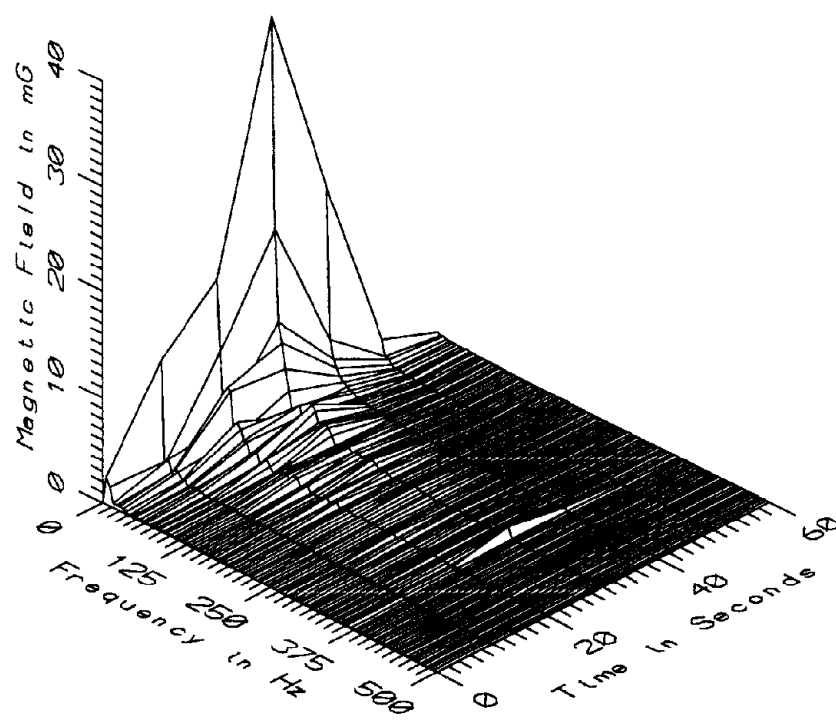

MET029 - -75cm FROM CENTERLINE OF MID DOORS ALONG AXIS OF CAR 2XXX

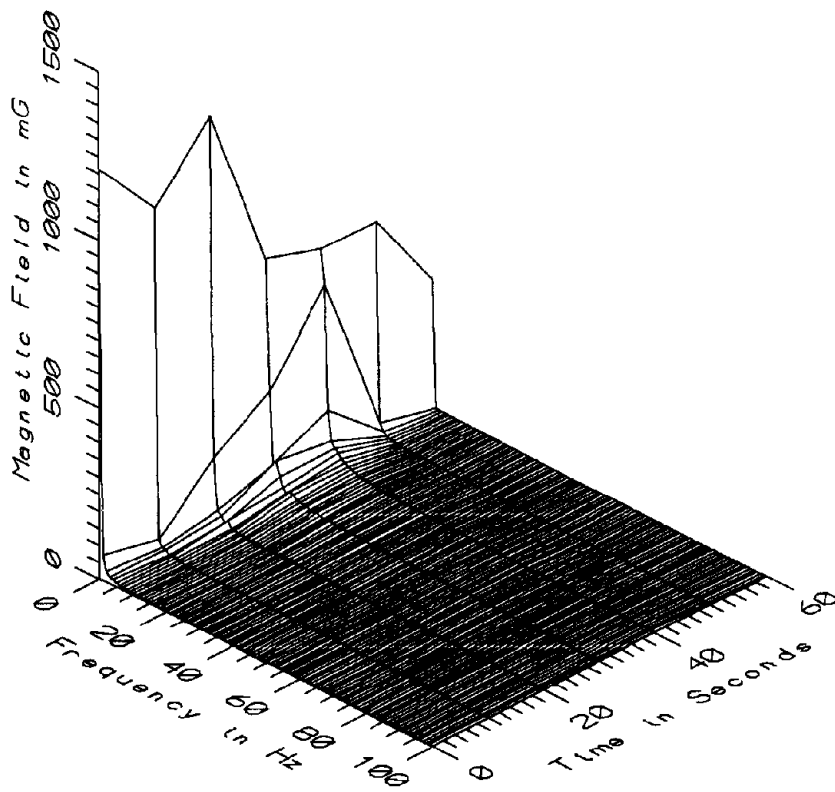

MET029 - -25cm FROM CENTERLINE OF MID DOORS ALONG AXIS OF CAR 2XXX

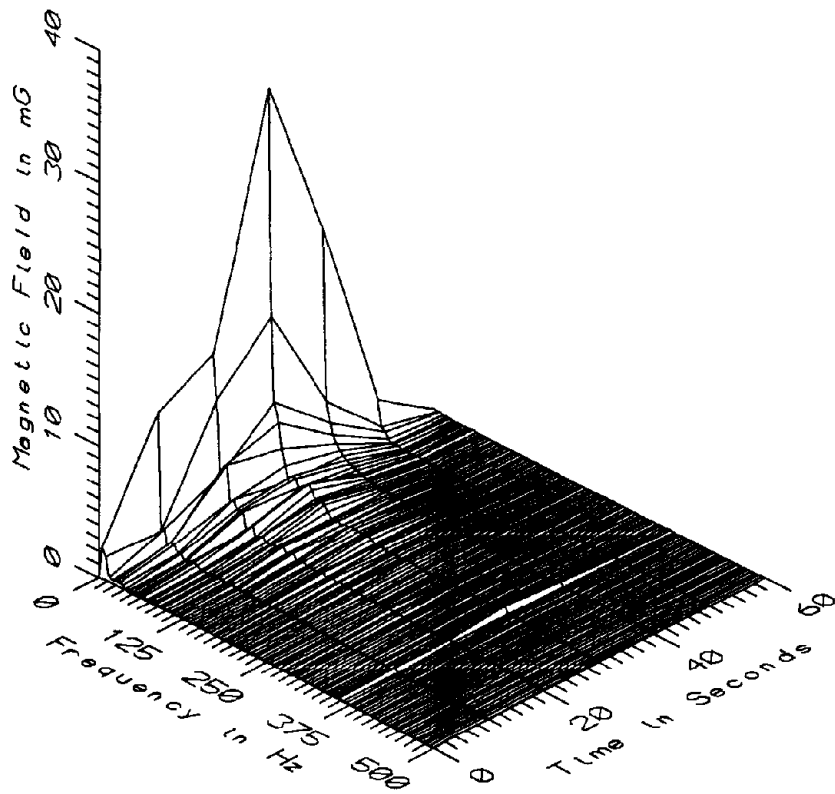

MET029 - -25cm FROM CENTERLINE OF MID DOORS ALONG AXIS OF CAR 2XXX

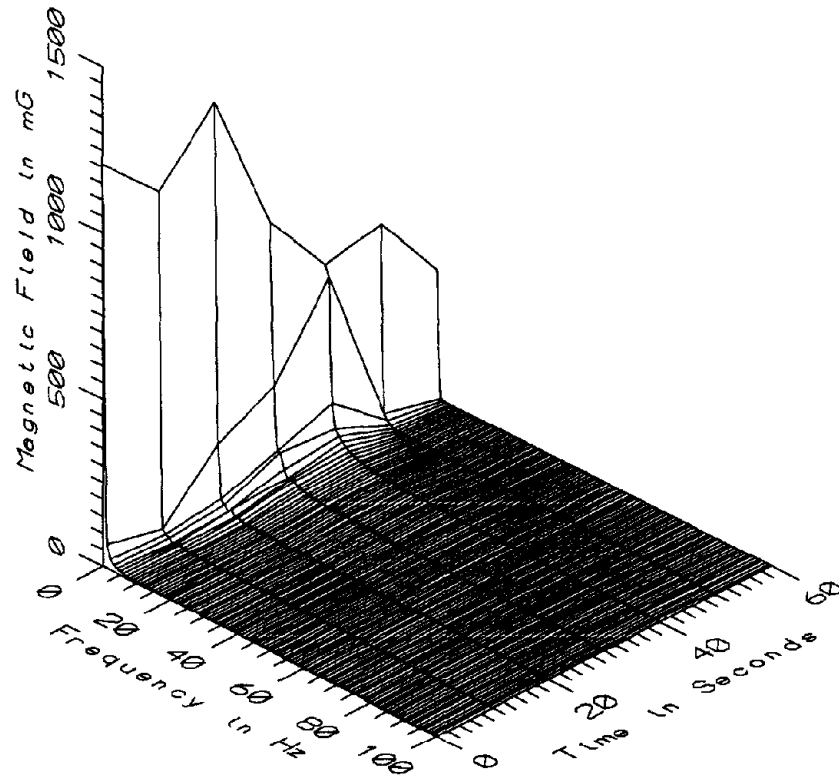

MET029 - 25cm FROM CENTERLINE OF MID DOORS ALONG AXIS OF CAR 2XXX

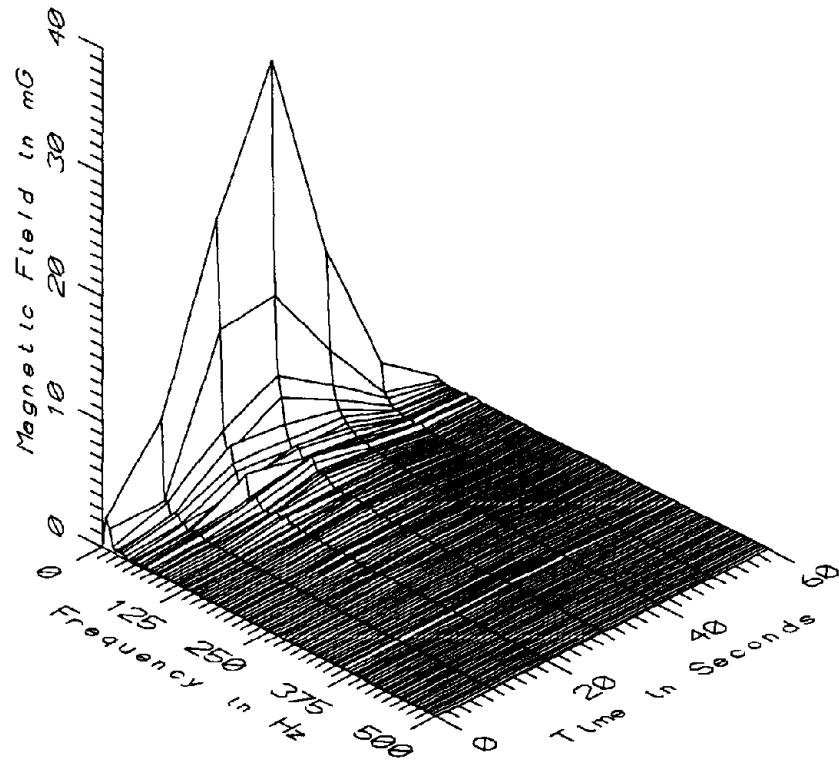

MET029 - 25cm FROM CENTERLINE OF MID DOORS ALONG AXIS OF CAR 2XXX

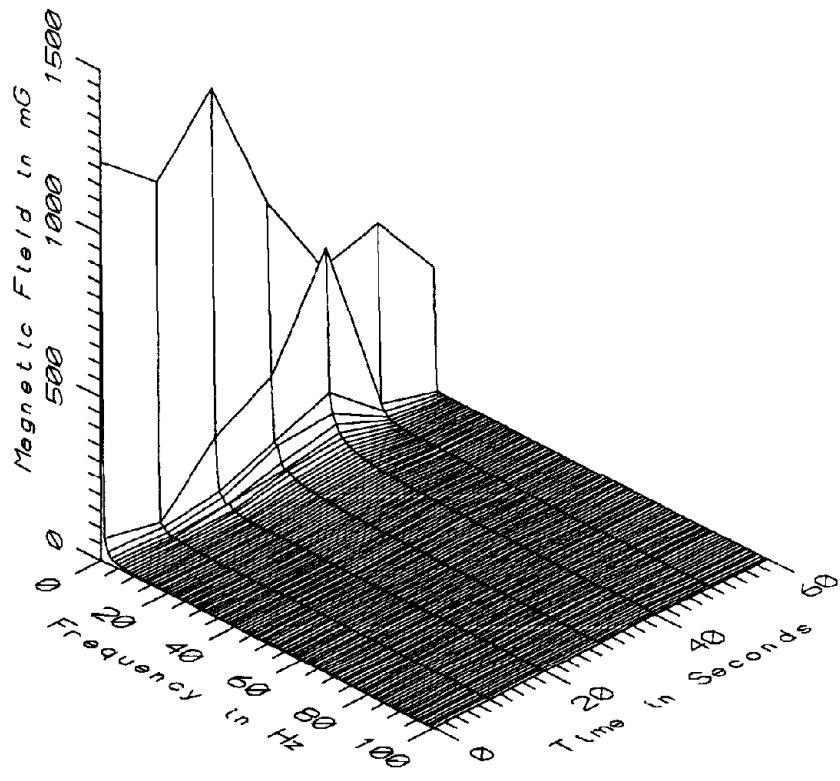

MET029 - 75cm FROM CENTERLINE OF MID DOORS ALONG AXIS OF CAR 2XXX

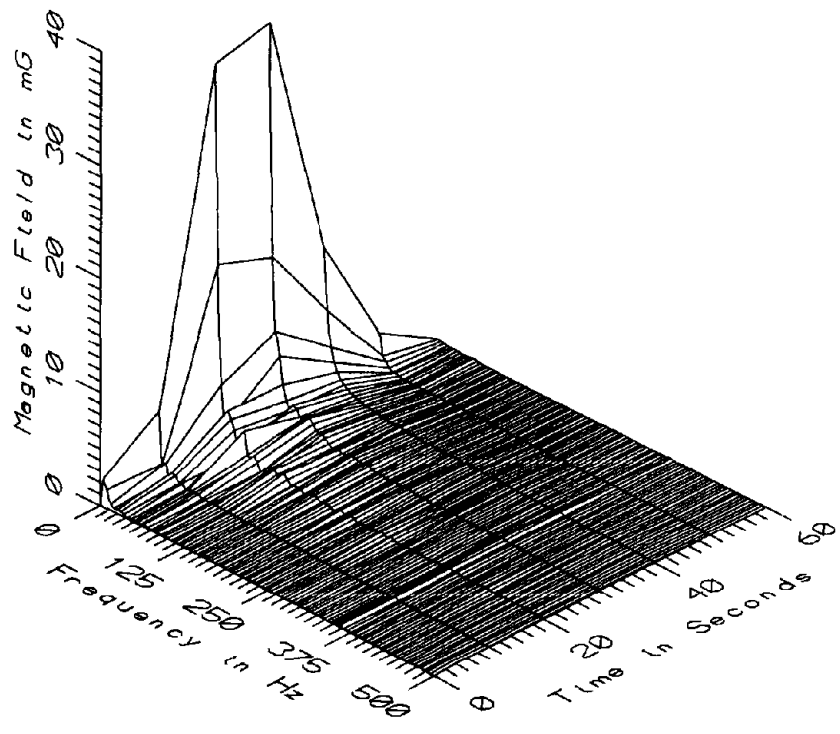

MET029 - 75cm FROM CENTERLINE OF MID DOORS ALONG AXIS OF CAR 2XXX

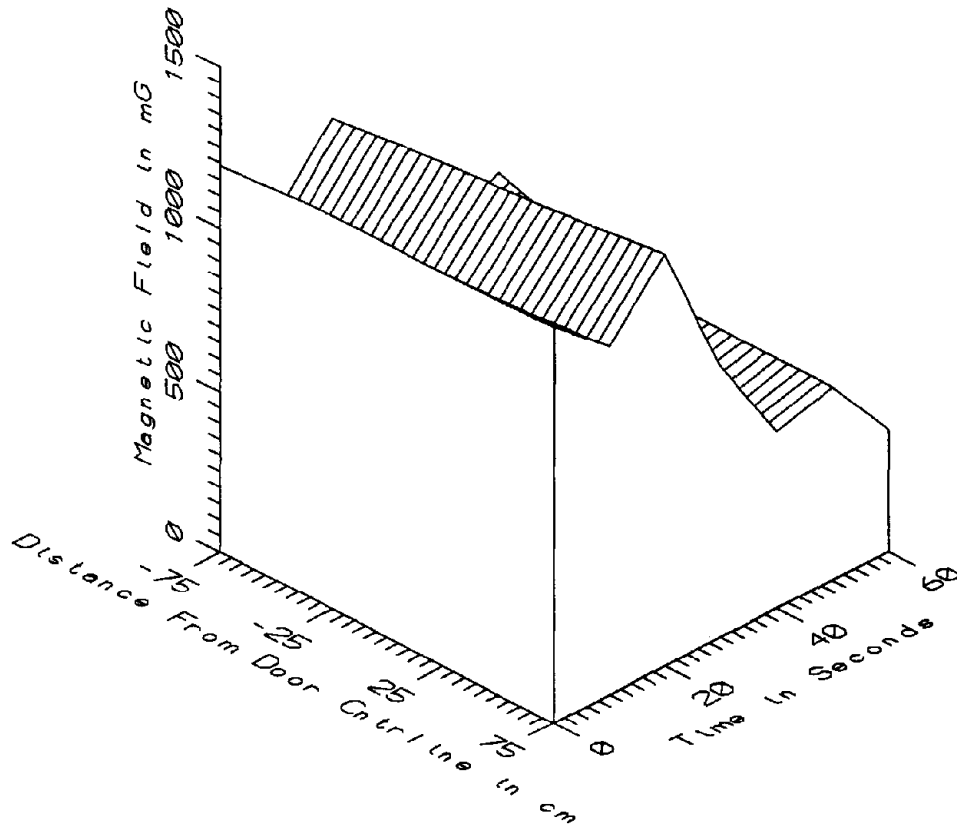

MET029 - AXIAL PROFILE, CENTER OF CAR 2XXX - STATIC

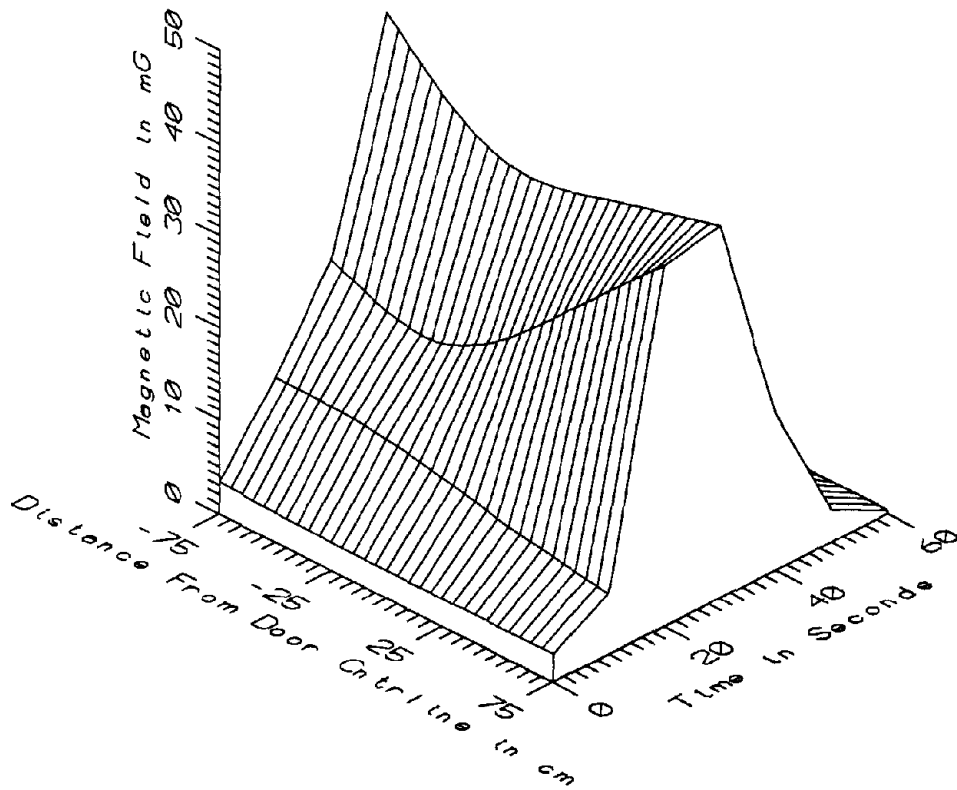

MET029 - AXIAL PROFILE, CENTER OF CAR 2XXX - LOW FREQ, 5-45Hz

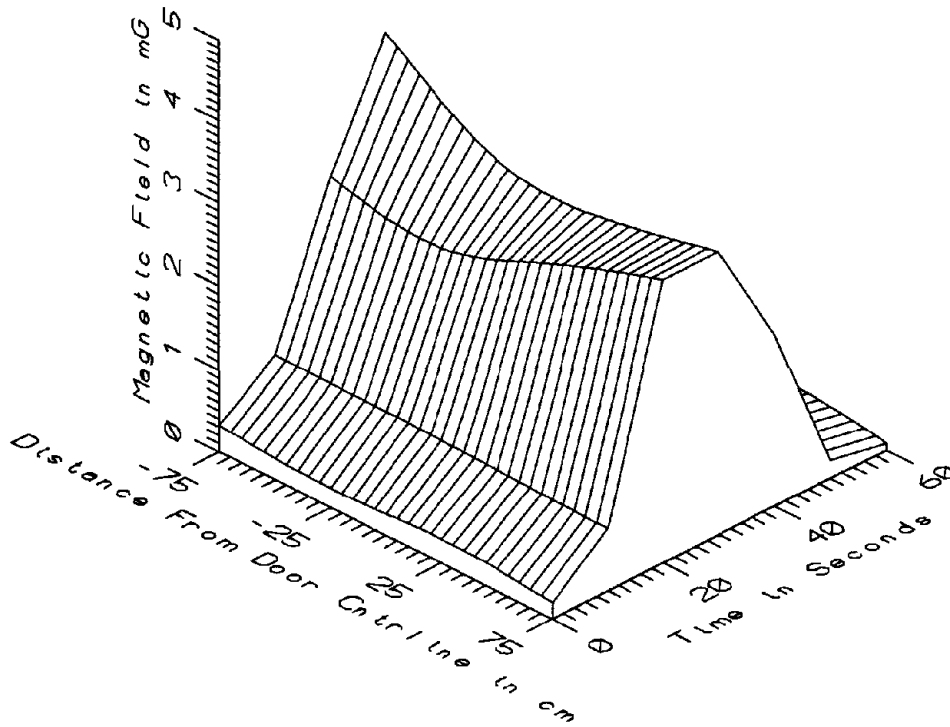

MET029 - AXIAL PROFILE, CENTER OF CAR 2XXX - POWER FREQ, 50-60Hz

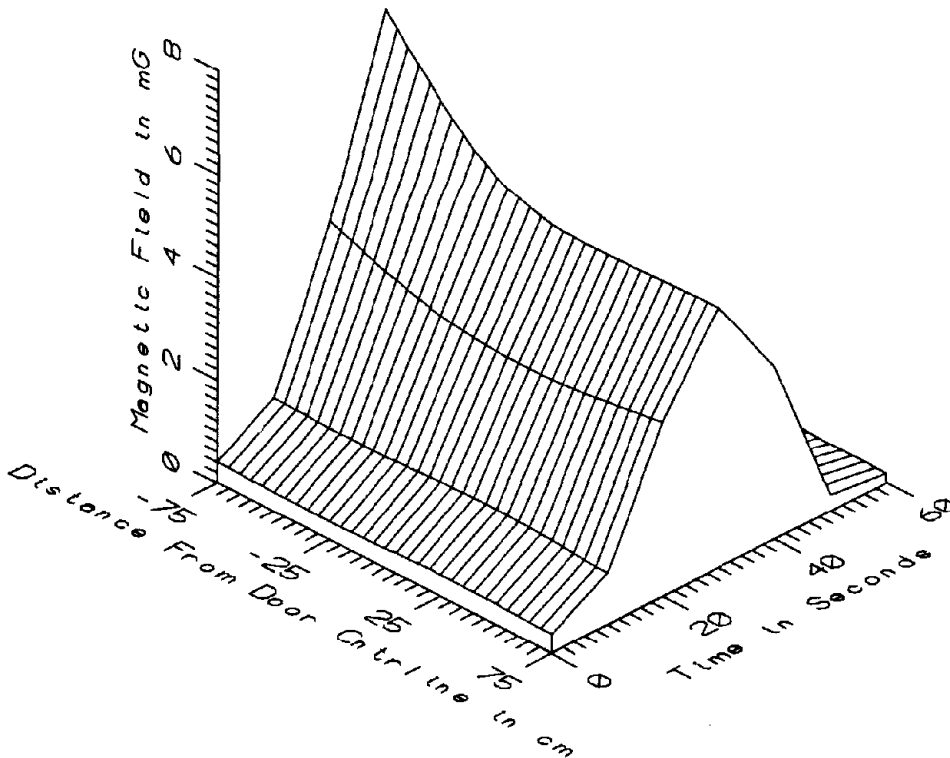

MET029 - AXIAL PROFILE, CENTER OF CAR 2XXX - POWER HARM, 65-300Hz

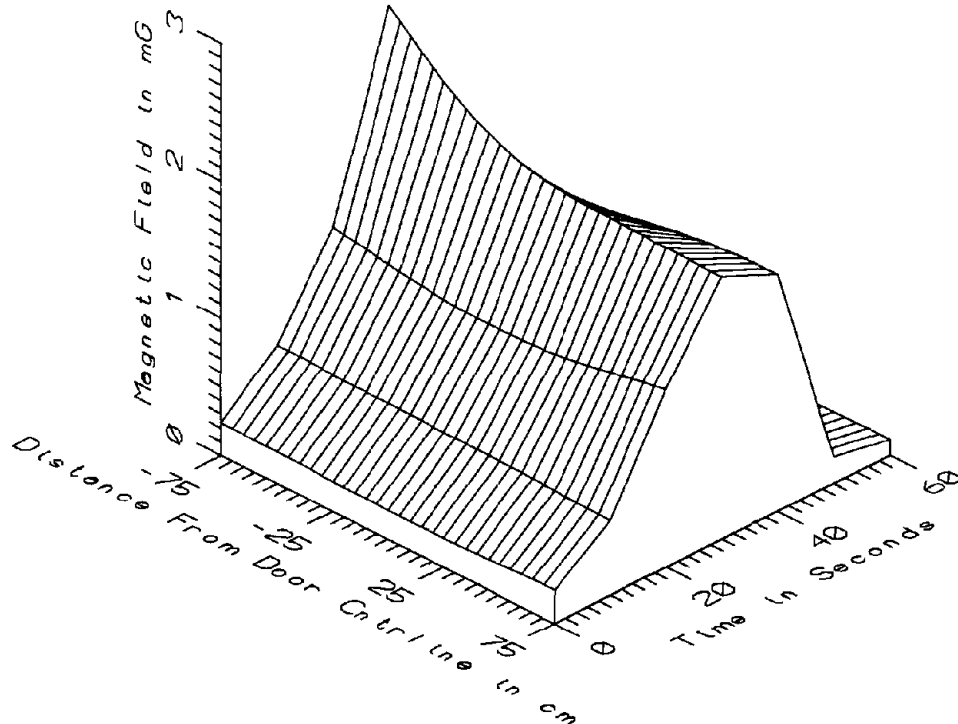

MET029 - AXIAL PROFILE, CENTER OF CAR 2XXX - HIGH FREQ, 305-2560Hz

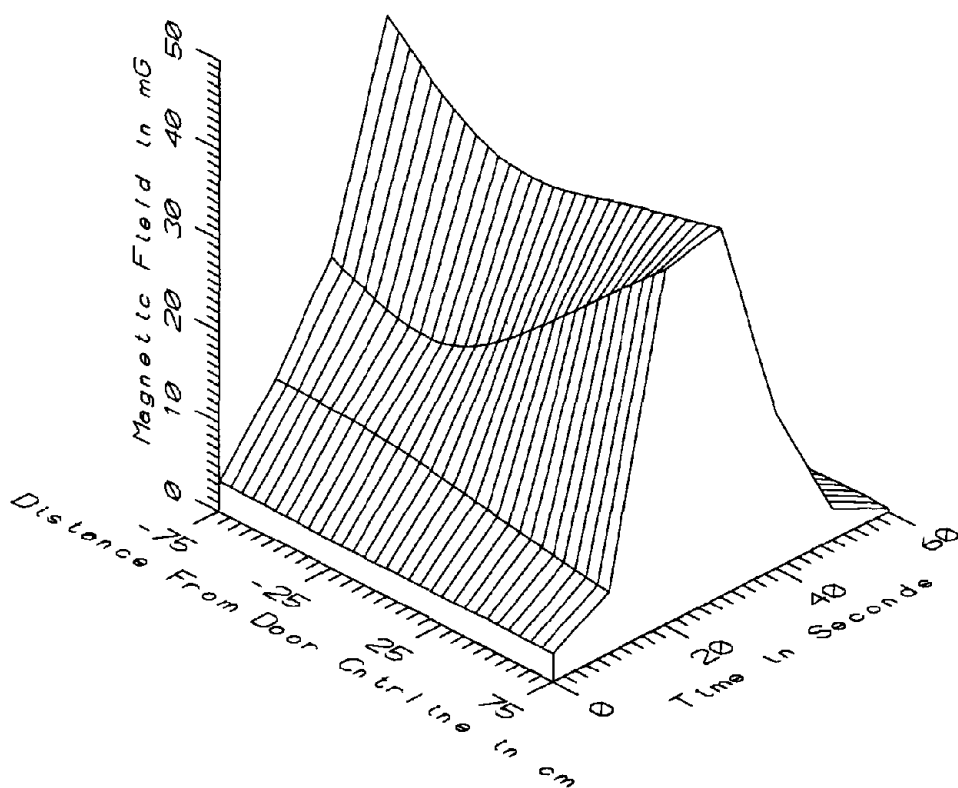

MET029 - AXIAL PROFILE, CENTER OF CAR 2XXX - ALL FREQ, 5-2560Hz



MET029 - AXIAL PROFILE IN CENTER OF A 2000 SERIES CAR		TOTAL OF 7 SAMPLES				
FREQUENCY BAND	DIST ALONG STAFF (cm)	MINIMUM MAGNETIC FIELD (mG)	MAXIMUM MAGNETIC FIELD (mG)	AVERAGE MAGNETIC FIELD (mG)	STANDARD DEVIATION (mG)	COEFFICIENT OF VARIATION (%)
STATIC	-75	372.09	1192.37	802.14	314.76	39.24
	-25	381.65	1212.93	825.17	319.58	38.73
	25	385.69	1229.15	831.38	333.36	40.10
	75	378.94	1269.17	846.68	350.47	41.39
5-45Hz	-75	0.50	44.84	15.04	15.69	104.33
LOW FREQ	-25	0.38	35.55	13.07	12.50	95.64
	25	0.38	36.94	14.03	13.81	98.43
	75	0.36	40.15	15.64	17.17	109.80
50-60Hz	-75	0.20	4.07	1.41	1.47	103.66
PWR FREQ	-25	0.07	3.16	1.25	1.22	97.70
	25	0.23	3.12	1.39	1.27	90.95
	75	0.09	3.42	1.45	1.50	103.37
65-300Hz	-75	0.10	7.56	2.30	2.73	118.73
PWR HARM	-25	0.19	5.40	1.93	1.97	102.18
	25	0.23	4.99	1.95	1.84	94.07
	75	0.19	5.06	1.94	1.95	100.65
305-2560Hz	-75	0.12	2.66	0.92	0.93	100.59
HIGH FREQ	-25	0.11	2.07	0.83	0.75	91.11
	25	0.10	1.93	0.83	0.75	90.34
	75	0.12	1.91	0.86	0.77	88.82
5-2560Hz	-75	0.56	45.73	15.32	16.00	104.47
ALL FREQ	-25	0.45	36.15	13.30	12.72	95.61
	25	0.51	37.46	14.27	13.98	97.99
	75	0.43	40.65	15.87	17.34	109.24



APPENDIX AA

DATASET MET030  
TRANSVERSE PROFILE IN CENTER OF A 2000 SERIES CAR

Measurement Setup Code:        Staff:    3     Reference: -  
   Drawing:  A-1

Vehicle Status:                Traveling on the Green Line

Measurement Date:             May 19, 1992

Measurement Time:            Start:     15:42:41  
   End:       15:43:27

Number of Samples:            4

Programmed Sample Interval:   5 sec

Actual Sample Interval:       15.3 sec

**Frequency Spectrum Parameters**

<u>Probe Type:</u>	<u>Wideband</u>	<u>Static</u>
Maximum Frequency (Hz)	2560	100
Minimum Frequency (Hz)	5	0
Spectral Bandwidth (Hz)	5	1

Missing Data: No reference probe

Saturated Data: None

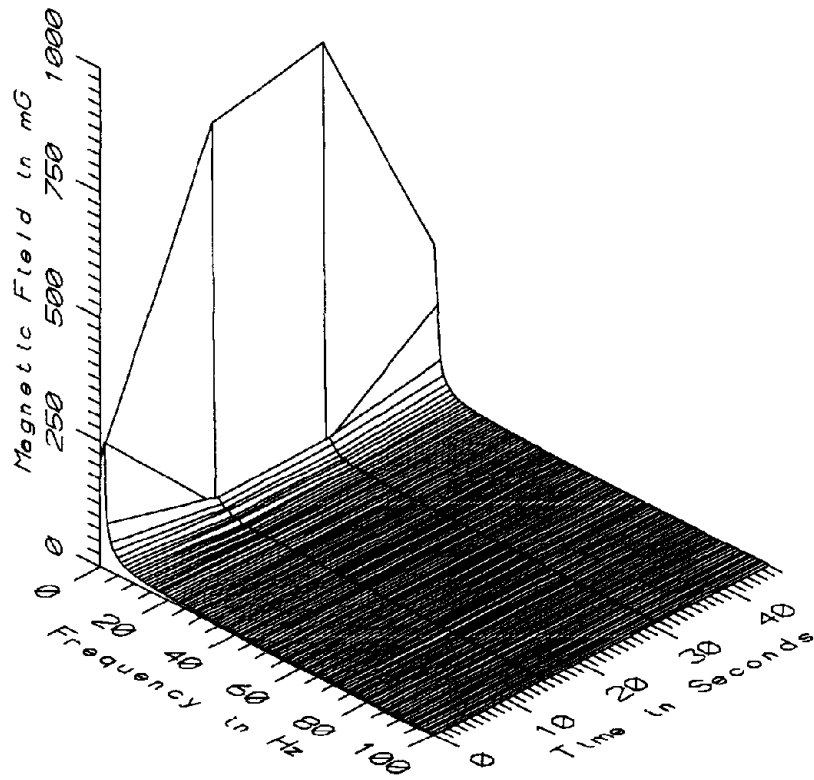

MET030 - -75cm FROM CAR CENTERLINE, CENTER OF CAR 2XXX

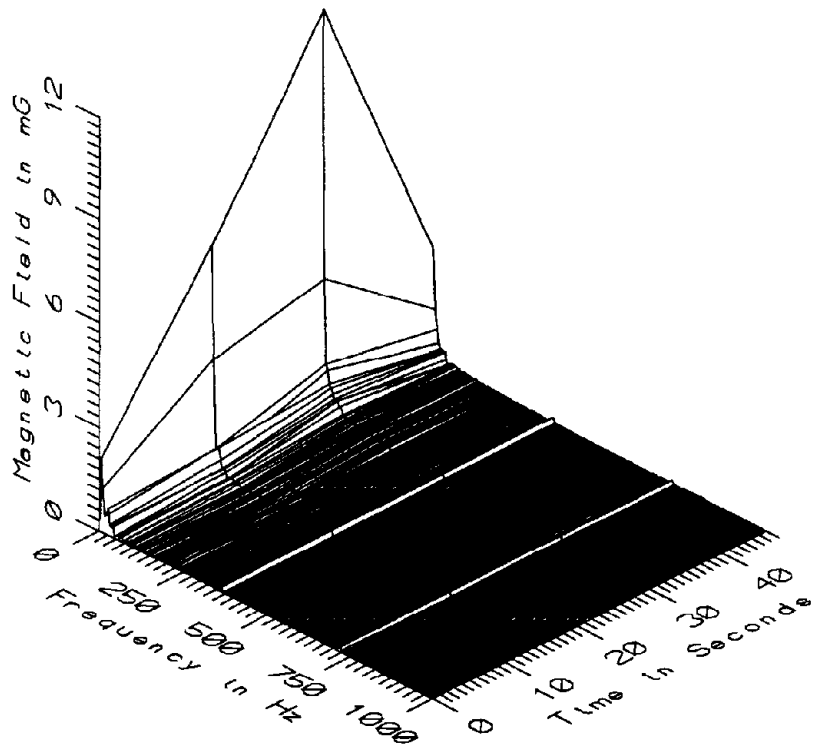

MET030 - -75cm FROM CAR CENTERLINE, CENTER OF CAR 2XXX

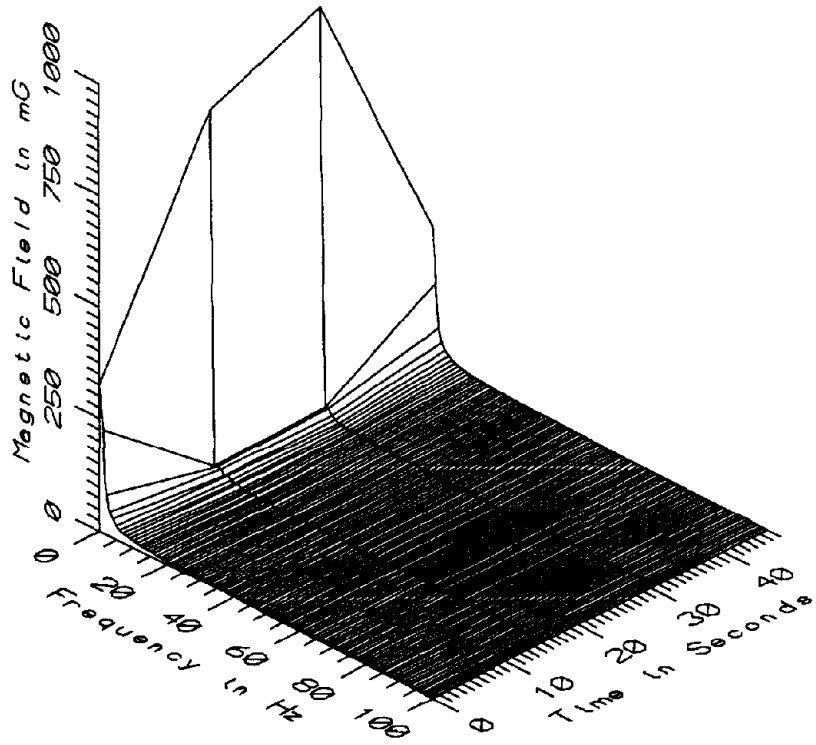

MET030 - -25cm FROM CAR CENTERLINE, CENTER OF CAR 2XXX

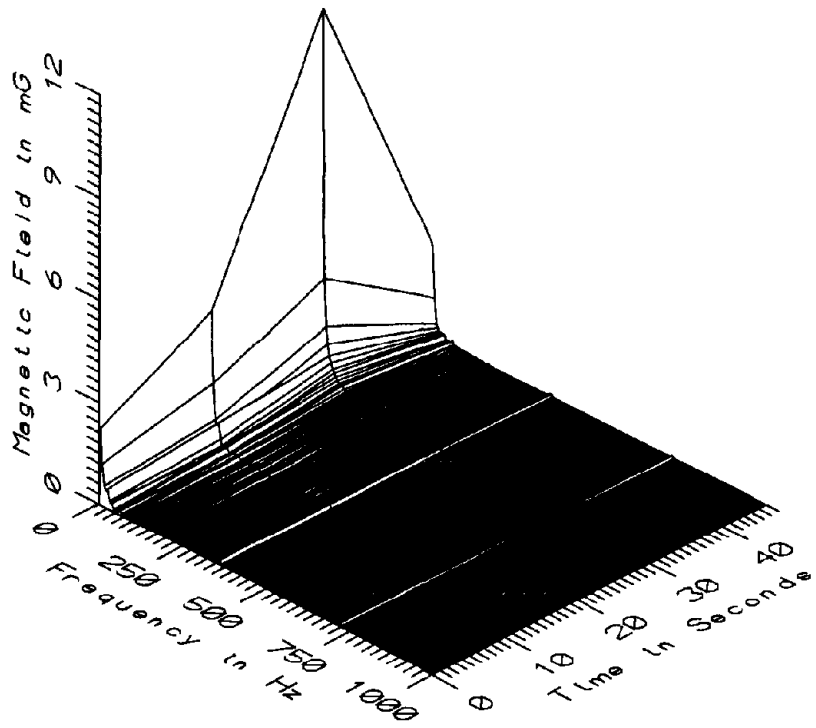

MET030 - -25cm FROM CAR CENTERLINE, CENTER OF CAR 2XXX

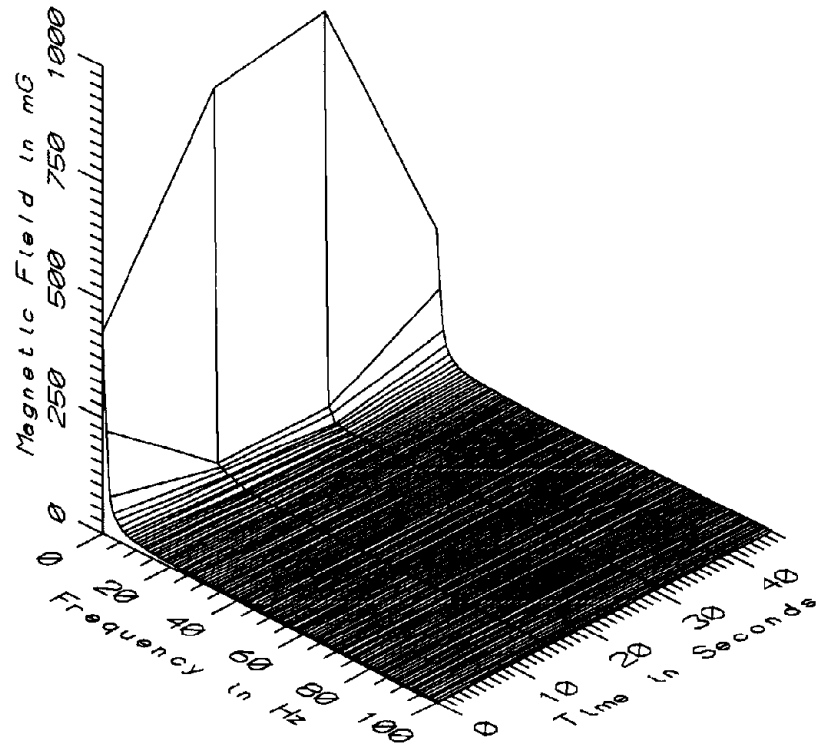

MET030 - 25cm FROM CAR CENTERLINE, CENTER OF CAR 2XXX

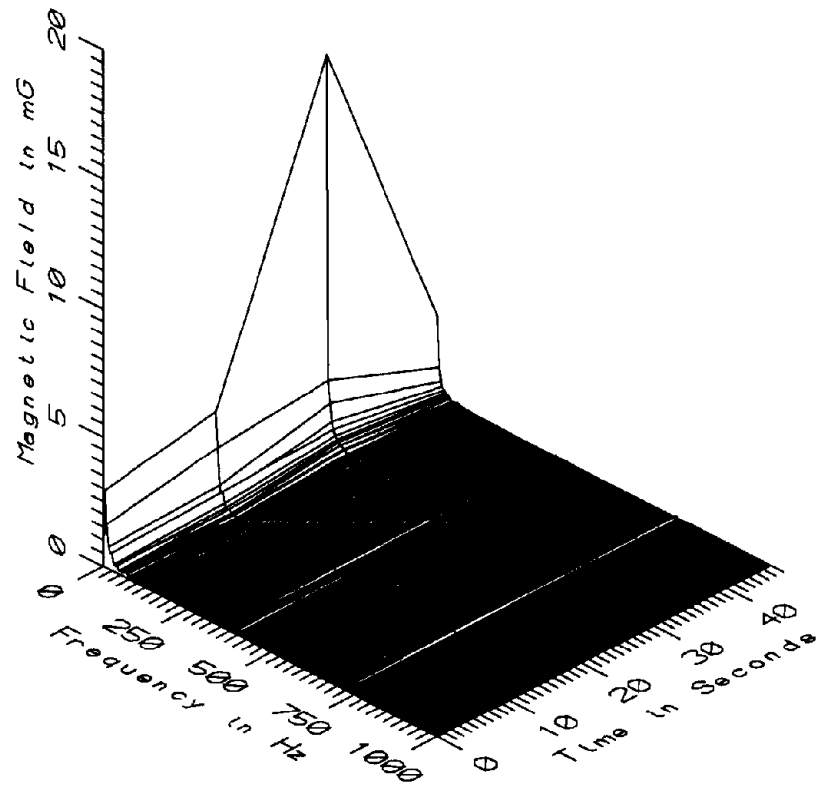

MET030 - 25cm FROM CAR CENTERLINE, CENTER OF CAR 2XXX

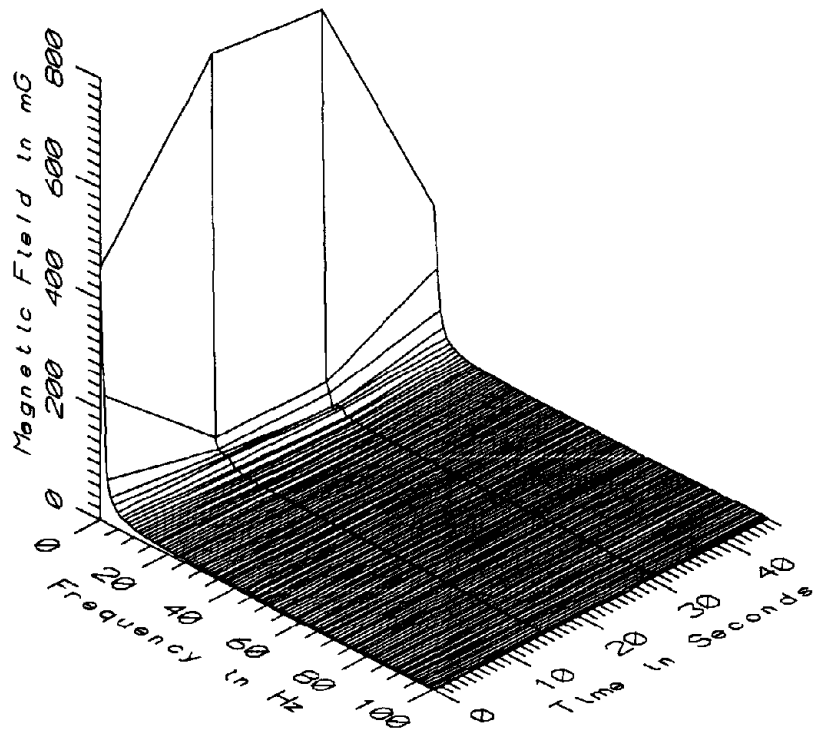

MET030 - 75cm FROM CAR CENTERLINE, CENTER OF CAR 2XXX

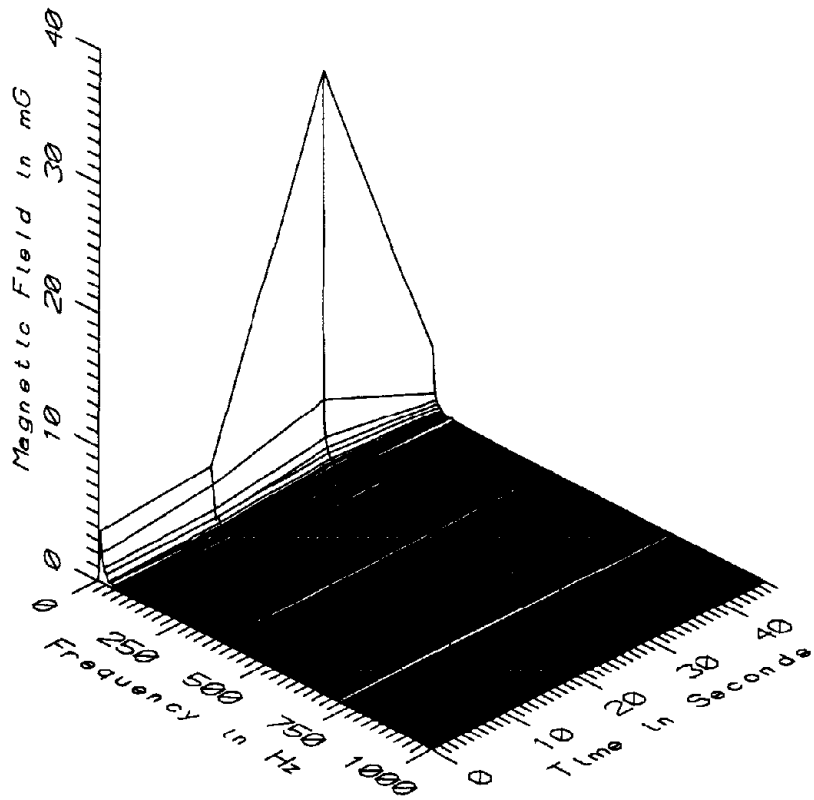

MET030 - 75cm FROM CAR CENTERLINE, CENTER OF CAR 2XXX

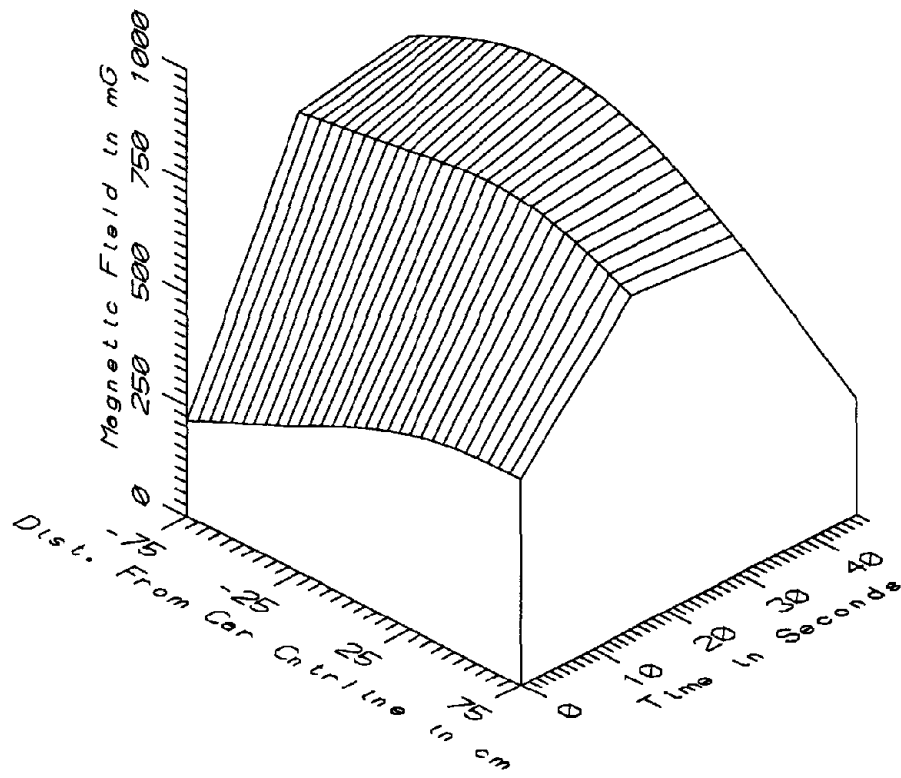

MET030 - TRANSVERSE PROFILE, CENTER OF CAR 2XXX - STATIC

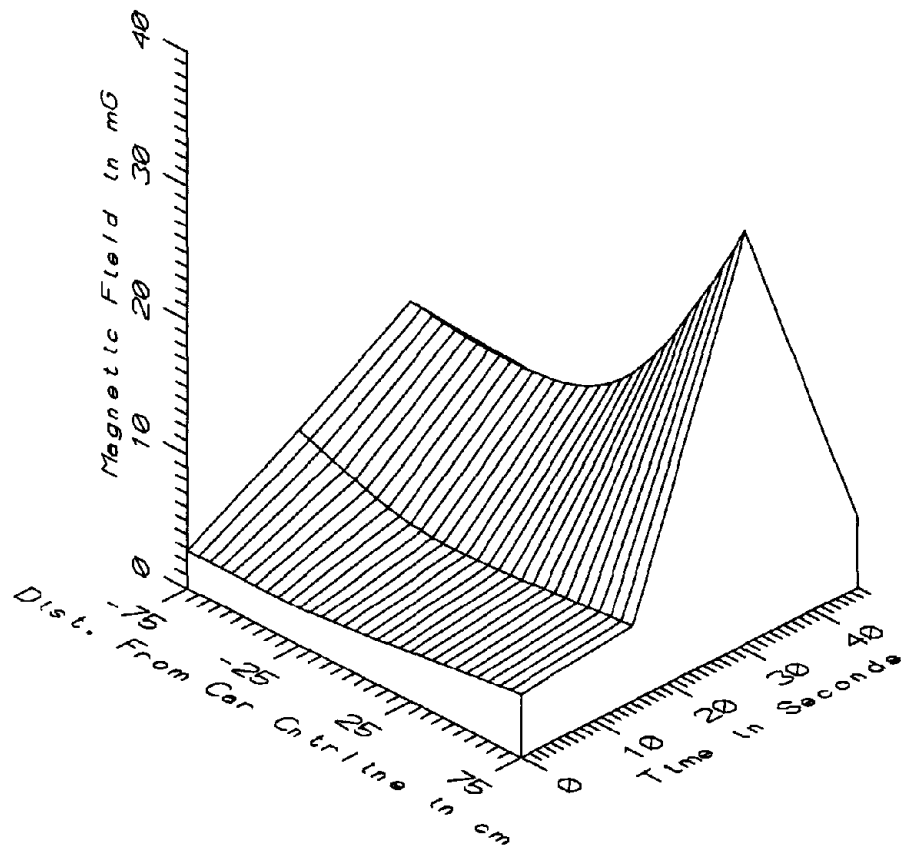

MET030 - TRANSVERSE PROFILE, CENTER OF CAR 2XXX - LOW FREQ, 5-45Hz



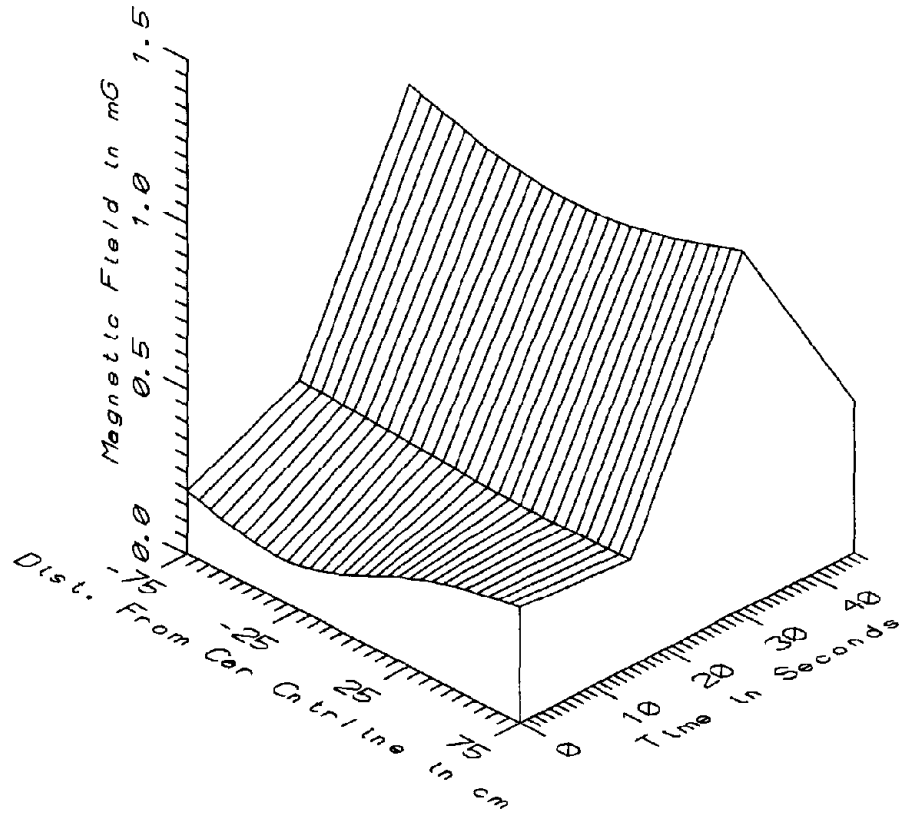

MET030 - TRANSVERSE PROFILE, CENTER OF CAR 2XXX - POWER FREQ, 50-60Hz

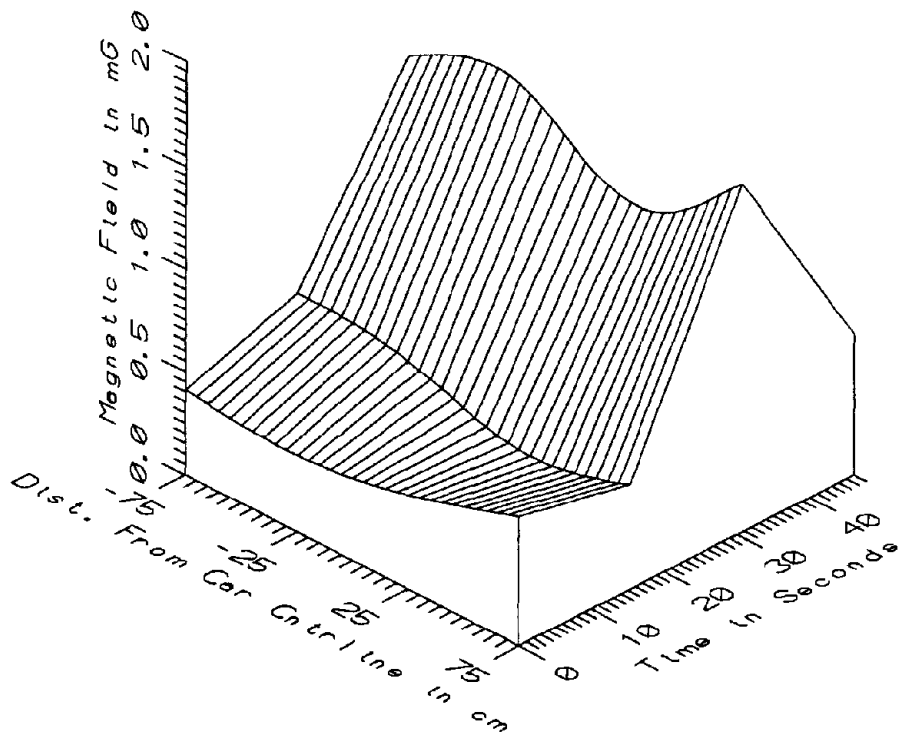

MET030 - TRANSVERSE PROFILE, CENTER OF CAR 2XXX - POWER HARM, 65-300Hz

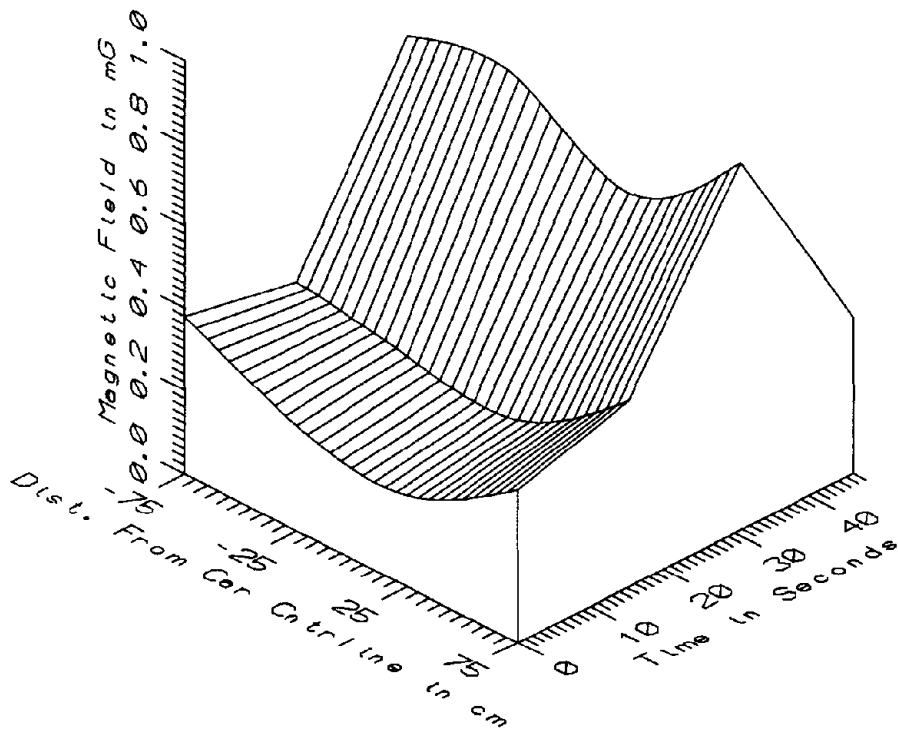

MET030 - TRANSVERSE PROFILE, CENTER OF CAR 2XXX - HIGH FREQ, 305-2560Hz

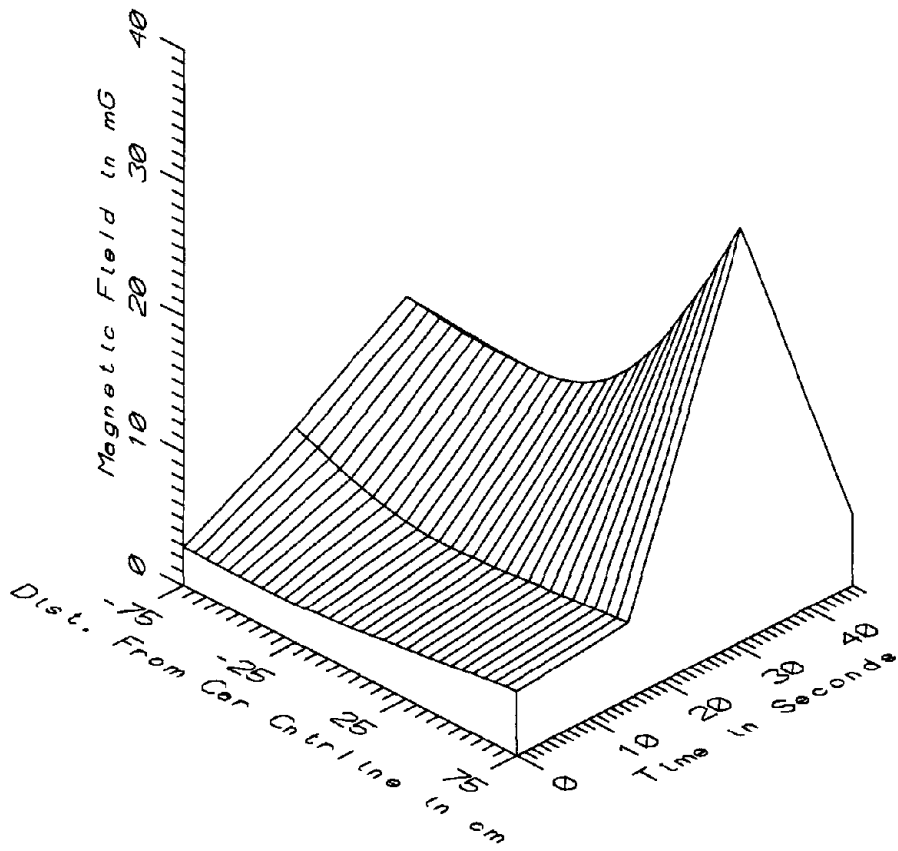

MET030 - TRANSVERSE PROFILE, CENTER OF CAR 2XXX - ALL FREQ, 5-2560Hz

MET030 - TRANSVERSE PROFILE, CENTER OF 2000 SERIES CAR TOTAL OF 4 SAMPLES										
FREQUENCY BAND	DIST ALONG STAFF (cm)	MINIMUM MAGNETIC FIELD (mG)	MAXIMUM MAGNETIC FIELD (mG)	AVERAGE MAGNETIC FIELD (mG)	STANDARD DEVIATION (mG)	COEFFICIENT OF VARIATION (%)				
STATIC	-75	215.23	824.96	531.60	314.30	59.12				
	-25	303.18	916.72	590.73	321.34	54.40				
	25	289.63	877.98	607.99	291.77	47.99				
	75	262.17	743.91	546.49	229.38	41.97				
5-45Hz	-75	2.81	12.91	6.80	4.55	66.93				
LOW FREQ	-25	2.80	12.26	5.73	4.43	77.33				
	25	3.64	16.04	7.05	6.01	85.24				
	75	4.74	30.79	11.61	12.79	110.20				
50-60Hz	-75	0.20	1.09	0.48	0.41	84.28				
PWR FREQ	-25	0.14	0.99	0.43	0.38	87.79				
	25	0.27	0.99	0.46	0.35	76.54				
	75	0.32	1.09	0.55	0.36	64.79				
65-300Hz	-75	0.41	1.49	0.79	0.48	60.30				
PWR HARM	-25	0.37	1.62	0.76	0.58	75.40				
	25	0.39	1.32	0.68	0.43	63.69				
	75	0.50	1.68	0.87	0.55	62.79				
305-2560Hz	-75	0.33	0.79	0.48	0.21	44.02				
HIGH FREQ	-25	0.25	0.82	0.41	0.27	66.07				
	25	0.22	0.68	0.37	0.21	57.62				
	75	0.37	0.89	0.52	0.25	47.70				
5-2560Hz	-75	2.87	13.06	6.89	4.59	66.61				
ALL FREQ	-25	2.84	12.43	5.82	4.49	77.25				
	25	3.70	16.14	7.11	6.04	84.88				
	75	4.80	30.87	11.68	12.80	109.61				



APPENDIX AB

DATASET MET031  
GALLERY PLACE PLATFORM, SOUTH BOUND SIDE

Measurement Setup Code:        Staff:     28    Reference: -  
   Drawing:  A-5

Vehicle Status:                NA

Measurement Date:              May 19, 1992

Measurement Time:              Start:     15:48:49  
   End:        15:51:20

Number of Samples:              26

Programmed Sample Interval:    5 sec

Actual Sample Interval:        6.0 sec

Frequency Spectrum Parameters

<u>Probe Type:</u>	<u>Wideband</u>	<u>Static</u>
Maximum Frequency (Hz)	2560	100
Minimum Frequency (Hz)	5	0
Spectral Bandwidth (Hz)	5	1

Missing Data: No reference probe

Saturated Data: None

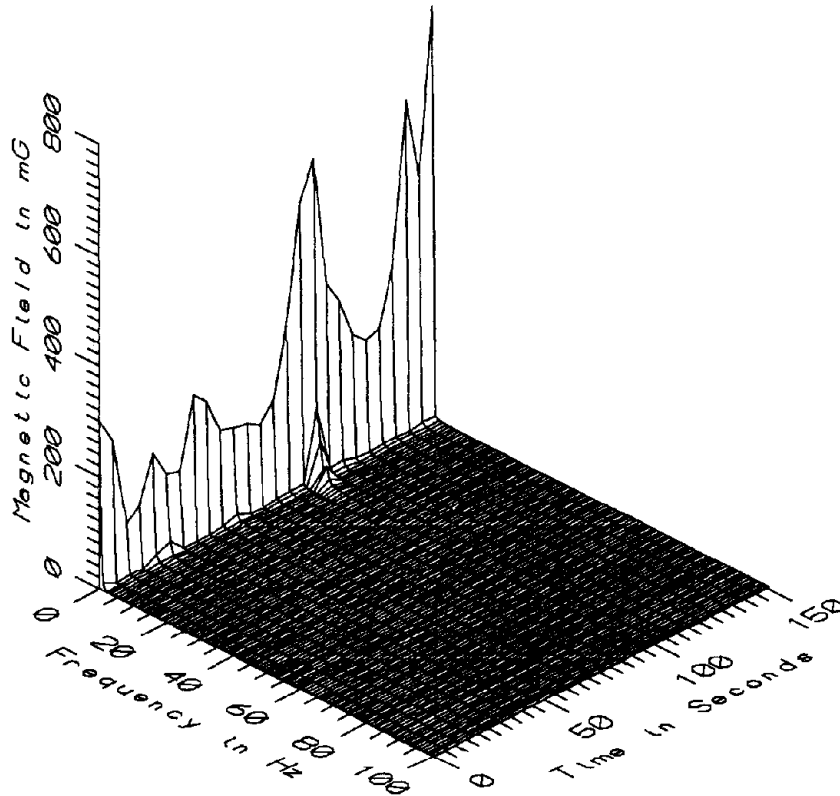

MET031 - 10cm ABOVE PLATFORM AT SAFETY LINE, SOUTH BOUND SIDE

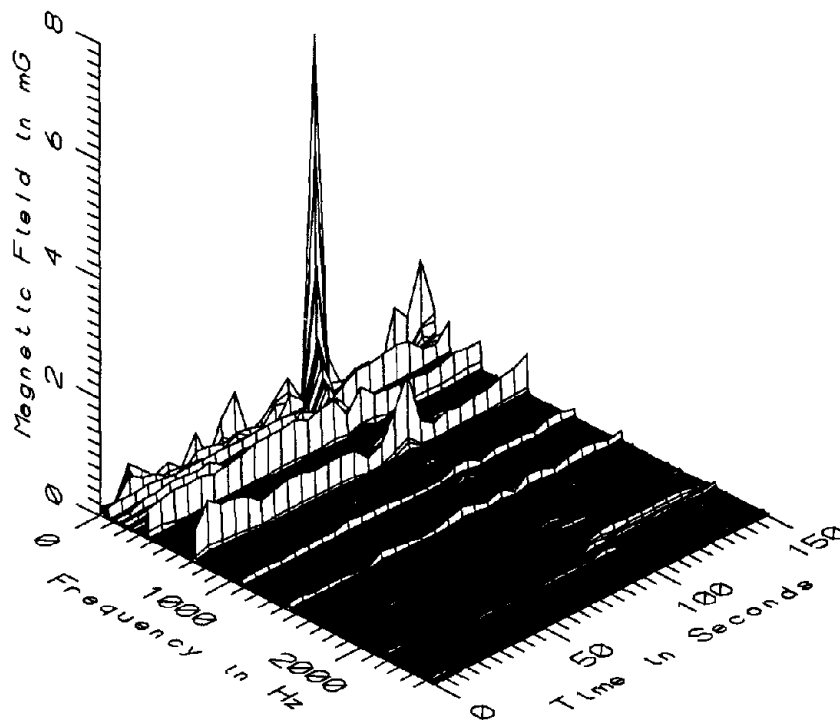

MET031 - 10cm ABOVE PLATFORM AT SAFETY LINE, SOUTH BOUND SIDE

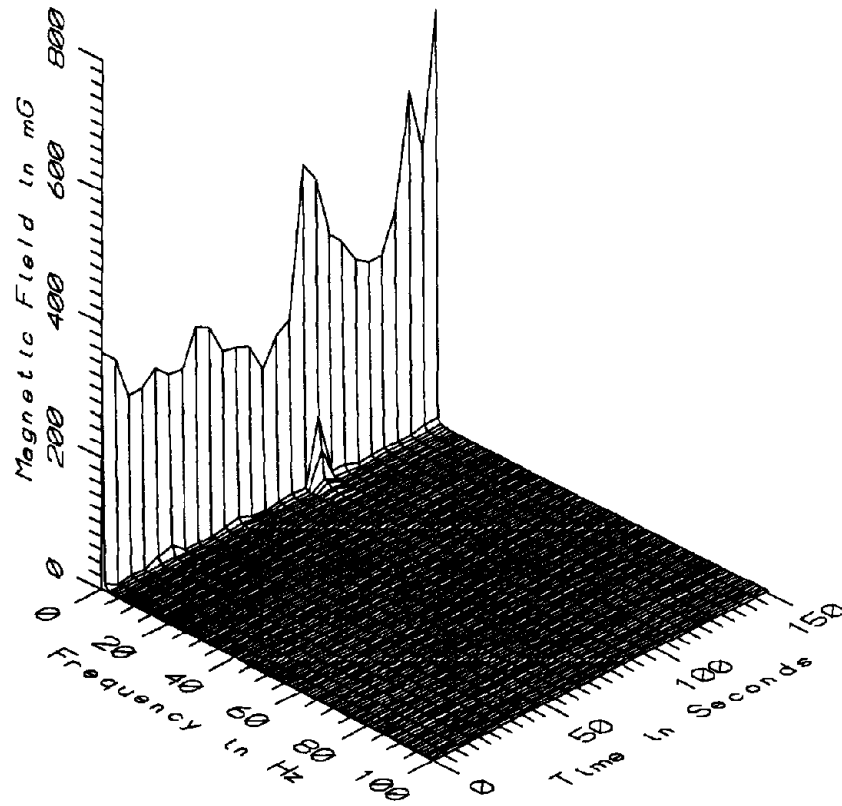

MET031 - 60cm ABOVE PLATFORM AT SAFETY LINE, SOUTH BOUND SIDE

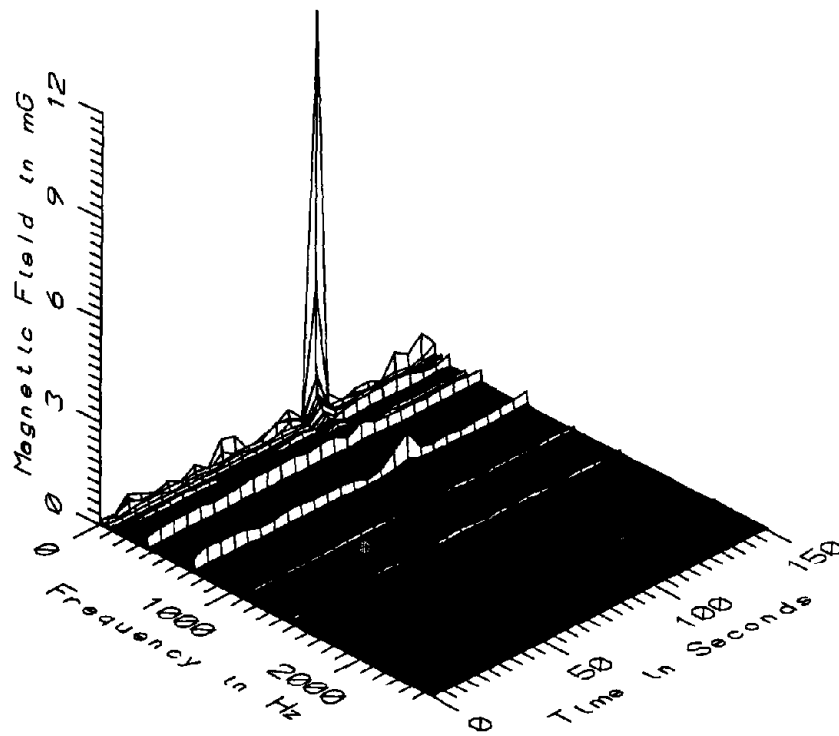

MET031 - 60cm ABOVE PLATFORM AT SAFETY LINE, SOUTH BOUND SIDE

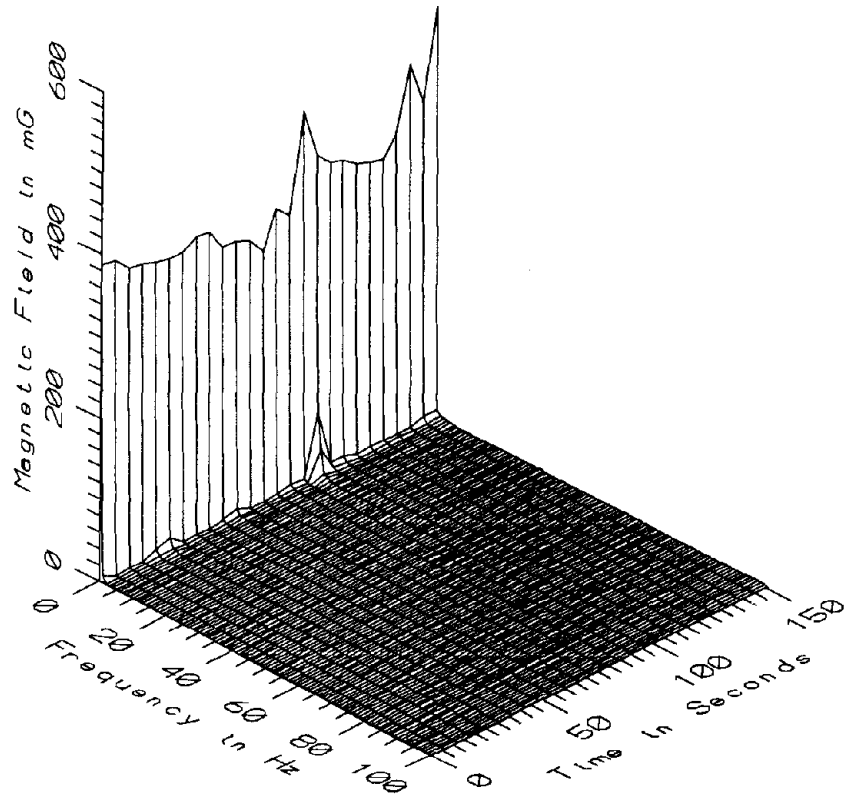

MET031 - 110cm ABOVE PLATFORM AT SAFETY LINE, SOUTH BOUND SIDE

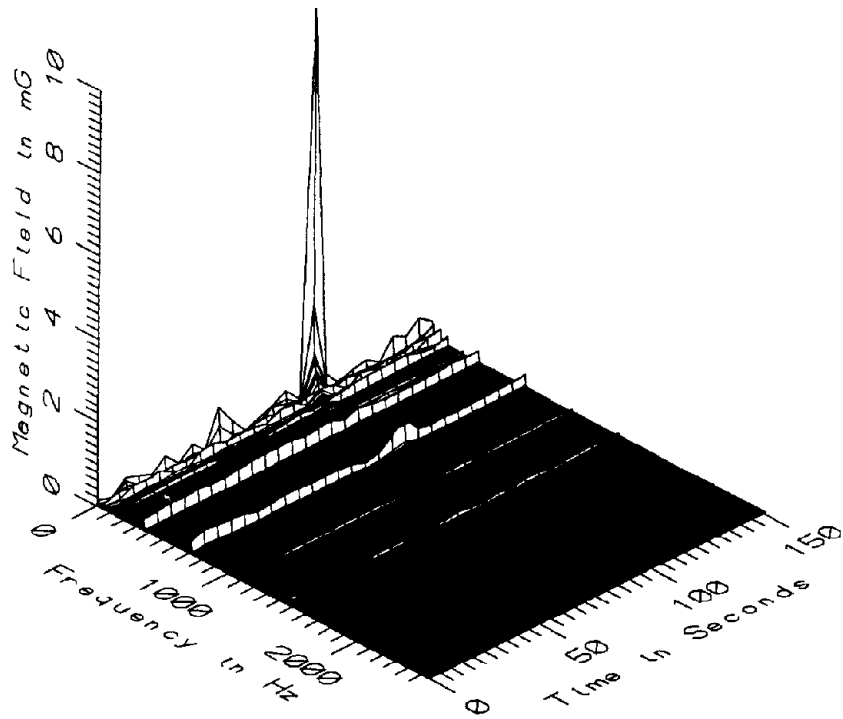

MET031 - 110cm ABOVE PLATFORM AT SAFETY LINE, SOUTH BOUND SIDE



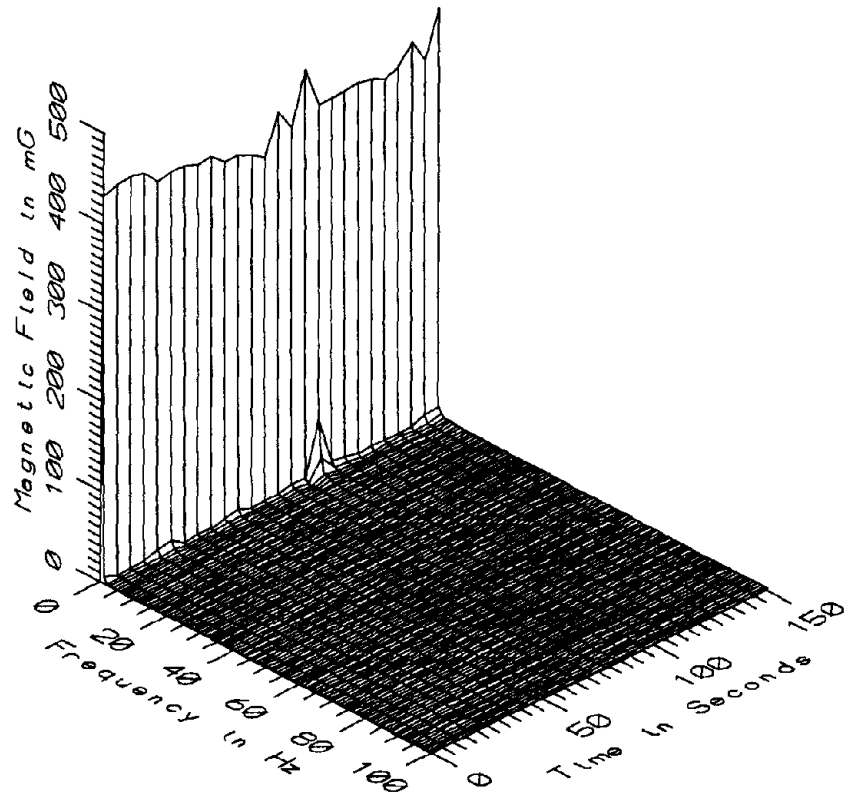

MET031 - 160cm ABOVE PLATFORM AT SAFETY LINE, SOUTH BOUND SIDE

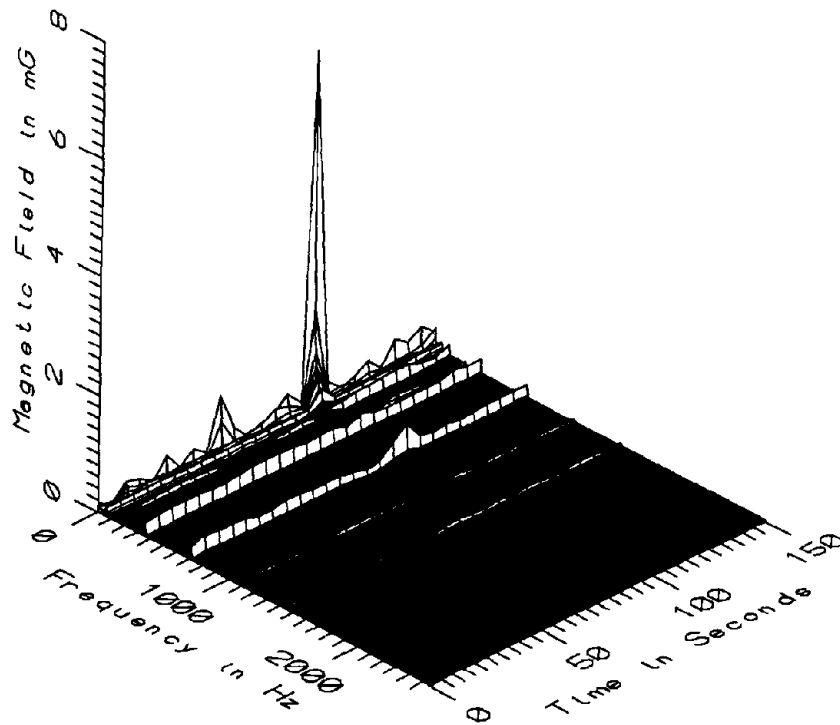

MET031 - 160cm ABOVE PLATFORM AT SAFETY LINE, SOUTH BOUND SIDE

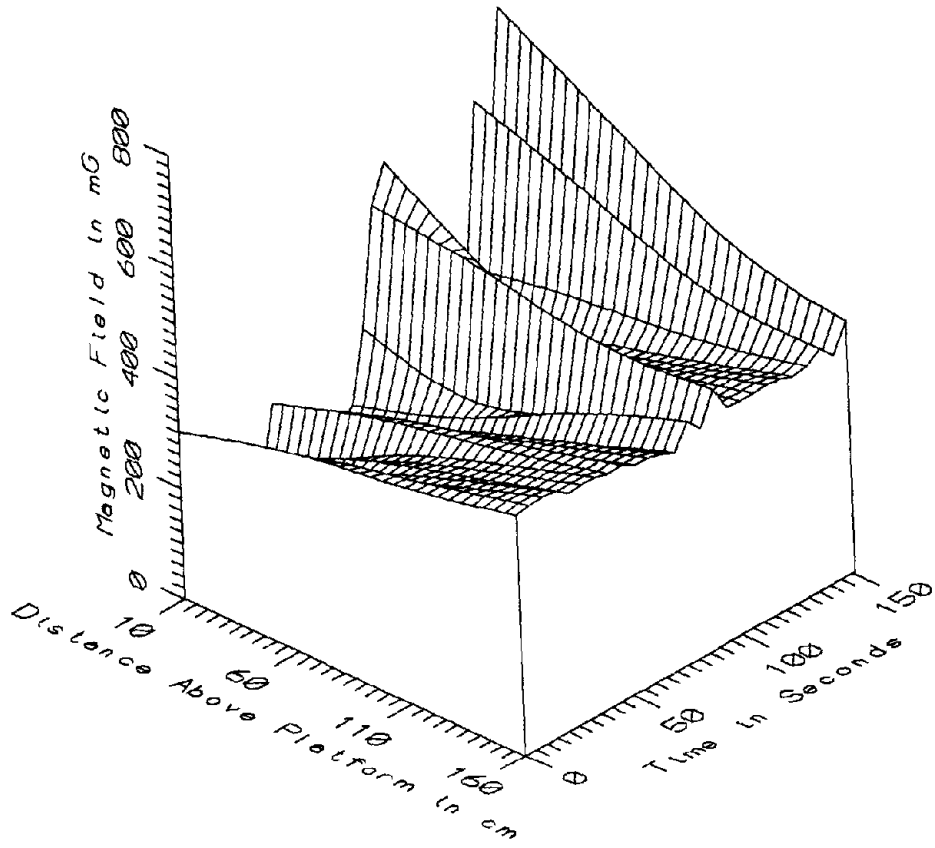

MET031 - AT SAFETY LINE, SOUTH BOUND SIDE - STATIC

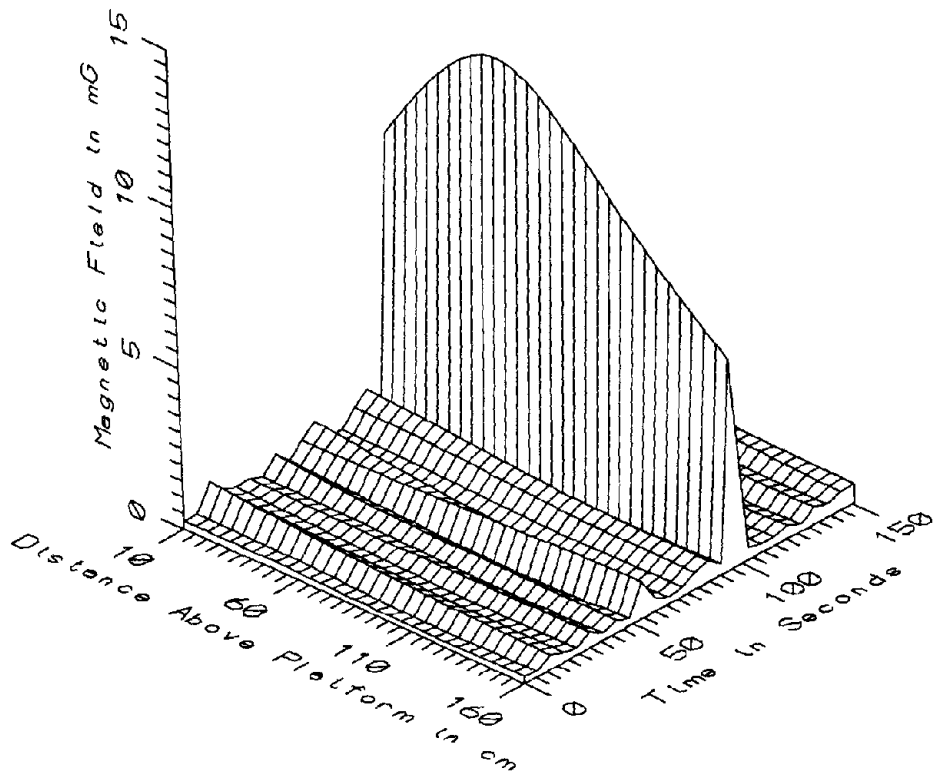

MET031 - AT SAFETY LINE, SOUTH BOUND SIDE - LOW FREQ. 5-45Hz

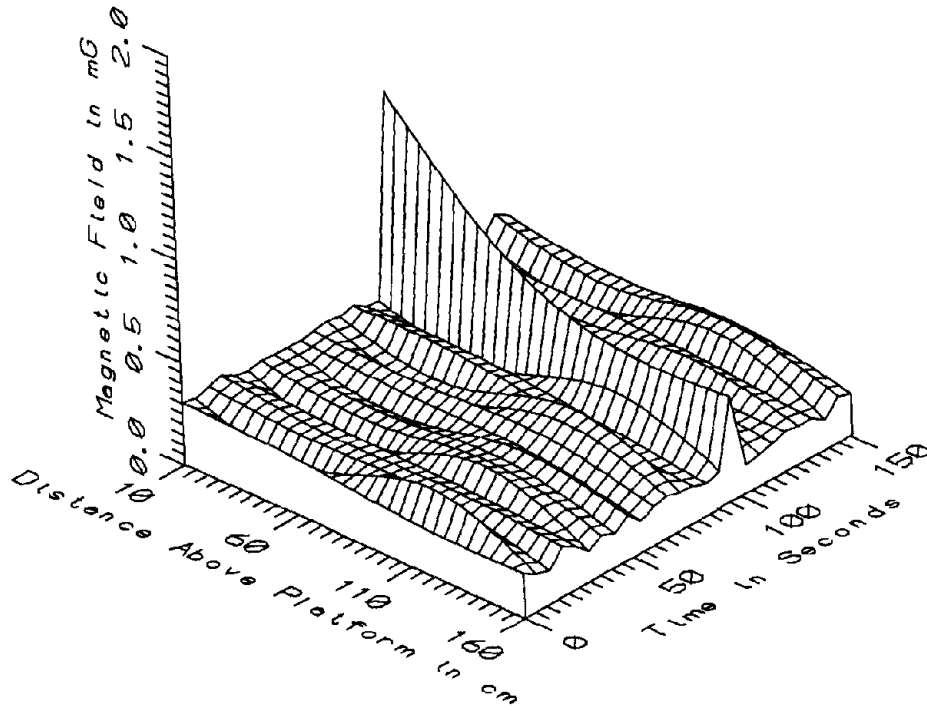

MET031 - AT SAFETY LINE, SOUTH BOUND SIDE - POWER FREQ, 50-60Hz

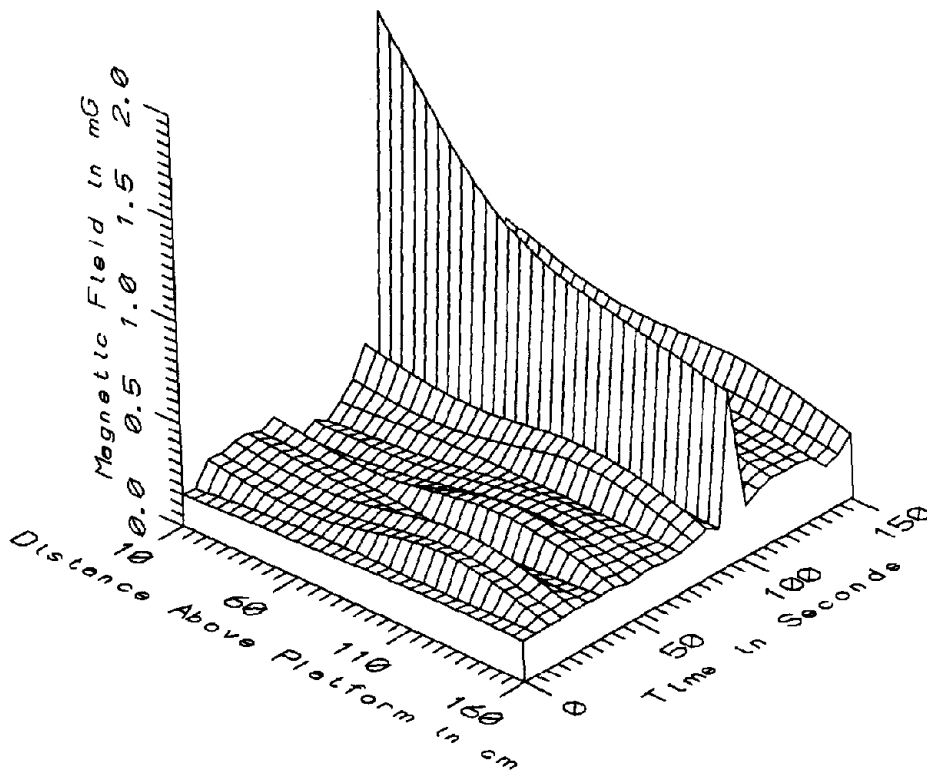

MET031 - AT SAFETY LINE, SOUTH BOUND SIDE - POWER HARM, 65-300Hz

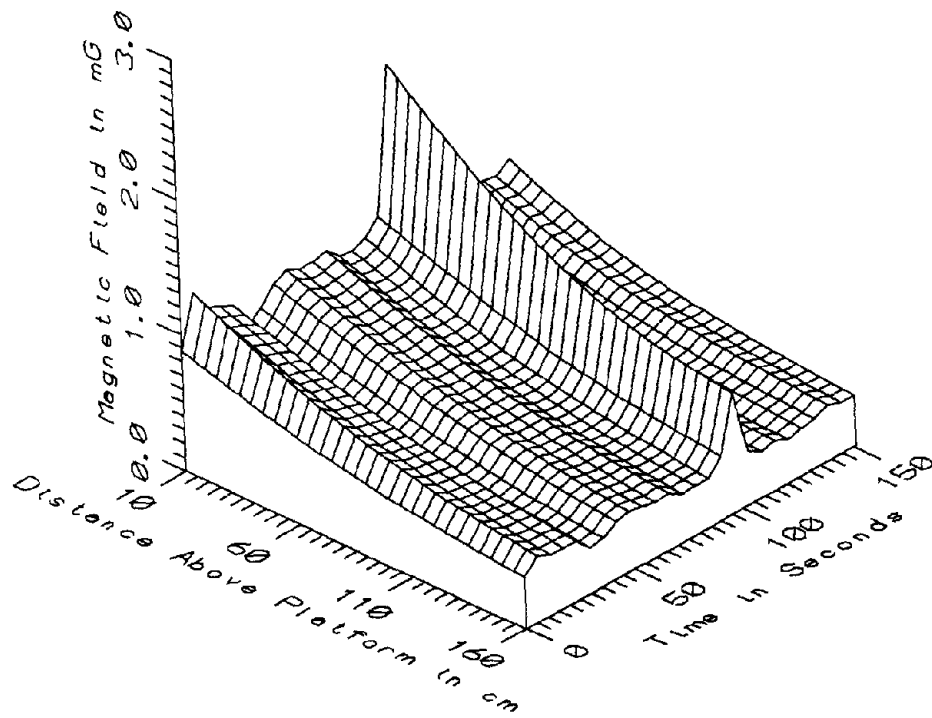

MET031 - AT SAFETY LINE, SOUTH BOUND SIDE - HIGH FREQ, 305-2560Hz

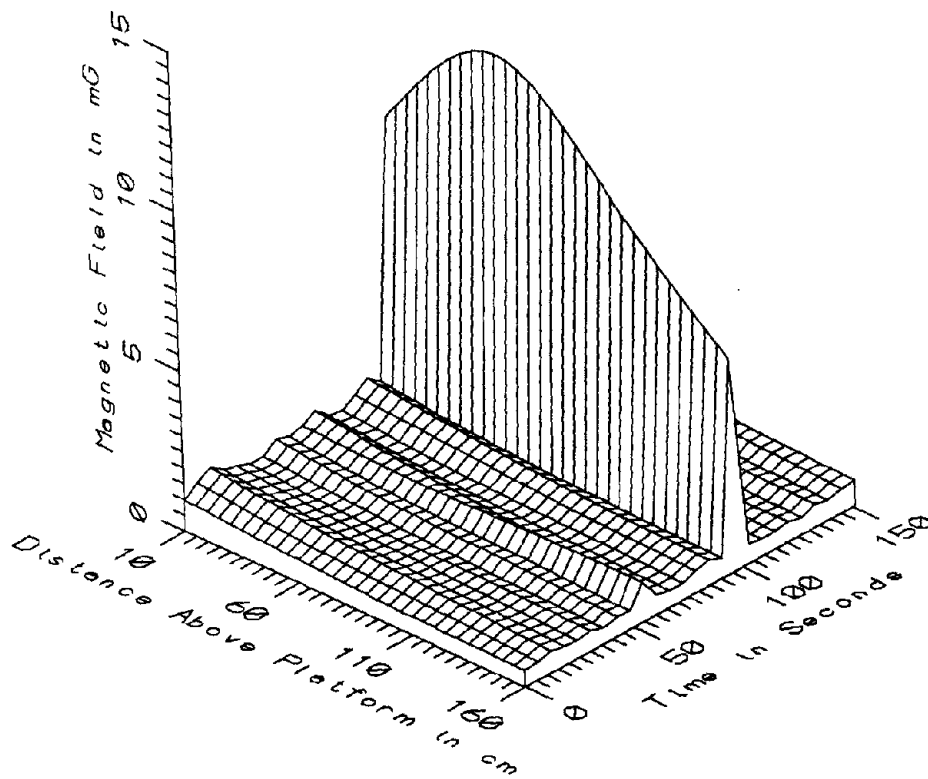

MET031 - AT SAFETY LINE, SOUTH BOUND SIDE - ALL FREQ, 5-2560Hz

MET031 - GALLERY PLACE PLATFORM, SOUTH BOUND SIDE		TOTAL OF 26 SAMPLES				
FREQUENCY BAND	HEIGHT ABOVE FLOOR (cm)	MINIMUM MAGNETIC FIELD (mG)	MAXIMUM MAGNETIC FIELD (mG)	AVERAGE MAGNETIC FIELD (mG)	STANDARD DEVIATION (mG)	COEFFICIENT OF VARIATION (%)
STATIC	10	93.73	741.39	282.52	165.78	58.68
	60	210.80	620.25	333.30	96.01	28.81
	110	306.48	503.00	370.97	41.70	11.24
	160	384.51	459.93	418.56	17.12	4.09
5-45Hz LOW FREQ	10	0.25	8.74	0.97	1.63	167.94
	60	0.18	12.74	0.97	2.41	247.99
	110	0.07	9.89	0.75	1.88	251.60
	160	0.18	6.52	0.65	1.21	188.14
50-60Hz PWR FREQ	10	0.26	1.26	0.33	0.19	57.41
	60	0.16	0.71	0.26	0.10	39.57
	110	0.22	0.50	0.30	0.06	20.43
	160	0.14	0.51	0.20	0.07	35.67
65-300Hz PWR HARM	10	0.12	1.94	0.40	0.37	90.94
	60	0.17	1.21	0.32	0.21	66.84
	110	0.17	0.97	0.32	0.15	46.92
	160	0.19	0.84	0.25	0.13	50.02
305-2560Hz HIGH FREQ	10	0.73	2.13	0.98	0.26	26.68
	60	0.52	1.48	0.69	0.18	26.32
	110	0.37	1.04	0.50	0.12	24.85
	160	0.31	0.86	0.40	0.10	25.81
5-2560Hz ALL FREQ	10	0.98	9.29	1.59	1.59	99.96
	60	0.73	12.90	1.40	2.35	167.73
	110	0.57	10.01	1.13	1.82	161.15
	160	0.50	6.64	0.88	1.18	134.29



APPENDIX AC

DATASET MET032  
GALLERY PLACE PLATFORM, SOUTH BOUND SIDE

Measurement Setup Code:        Staff:    30    Reference: -  
   Drawing:  A-5

Vehicle Status:                NA

Measurement Date:              May 19, 1992

Measurement Time:              Start:    15:51:47  
   End:      15:53:15

Number of Samples:             15

Programmed Sample Interval:    5 sec

Actual Sample Interval:        6.3 sec

Frequency Spectrum Parameters

<u>Probe Type:</u>	<u>Wideband</u>	<u>Static</u>
Maximum Frequency (Hz)	2560	100
Minimum Frequency (Hz)	5	0
Spectral Bandwidth (Hz)	5	1

Missing Data: No reference probe

Saturated Data: None

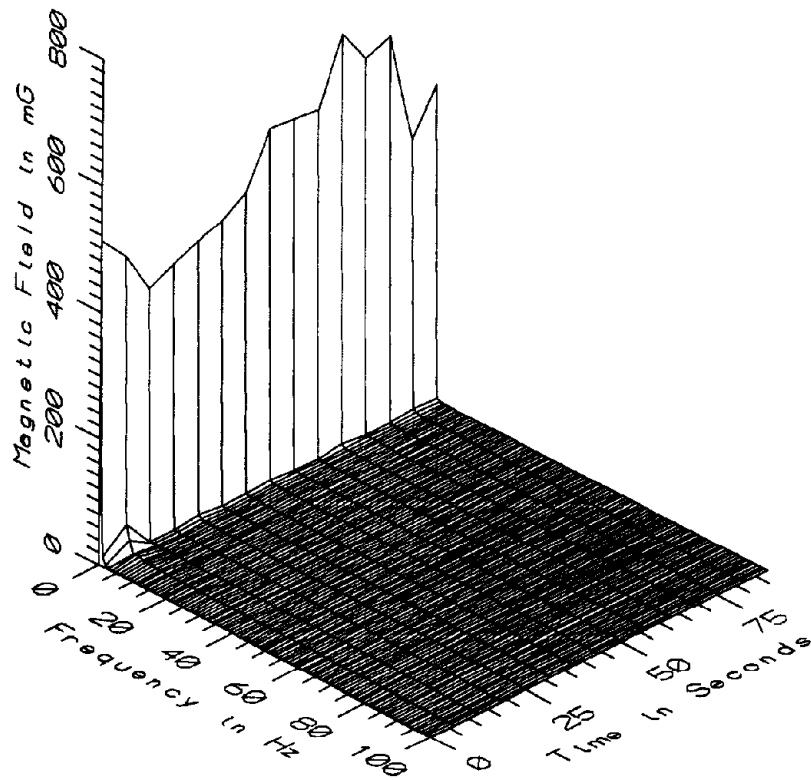

MET032 - 0cm FROM SAFETY LINE, 1M ABOVE PLATFORM, SOUTH BOUND SIDE

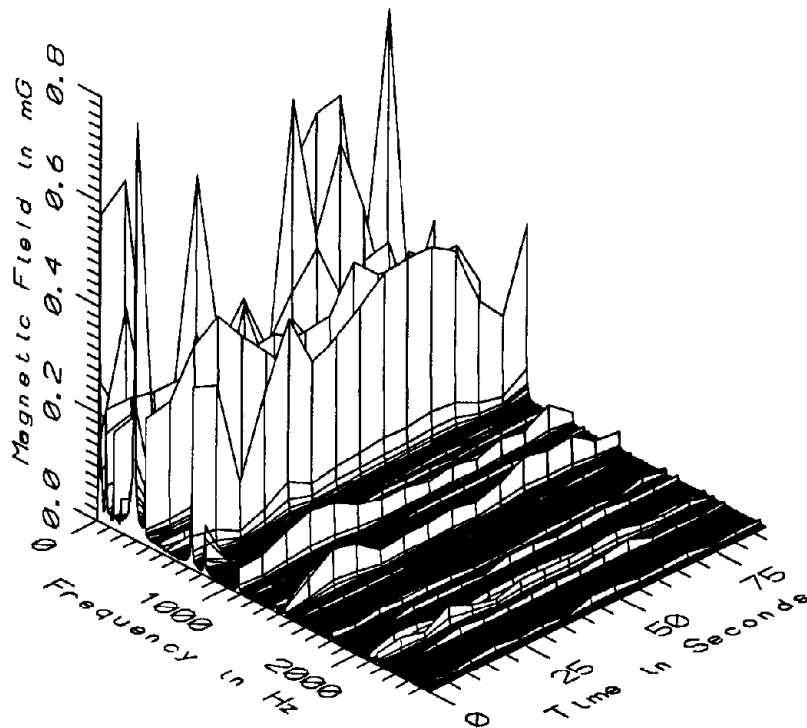

MET032 - 0cm FROM SAFETY LINE, 1M ABOVE PLATFORM, SOUTH BOUND SIDE



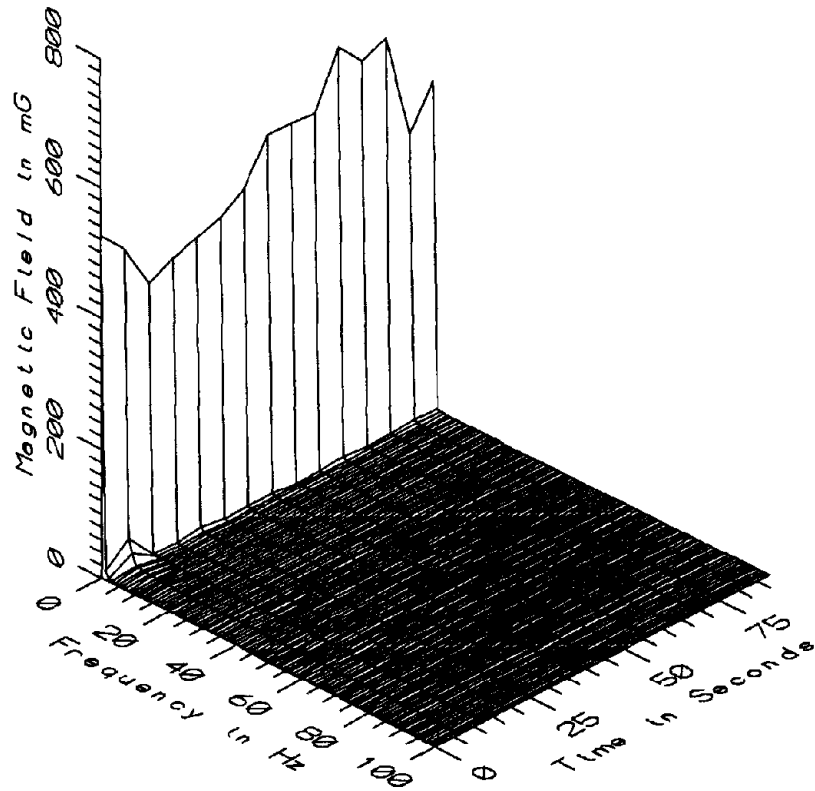

MET032 - 50cm FROM SAFETY LINE, 1M ABOVE PLATFORM, SOUTH BOUND SIDE

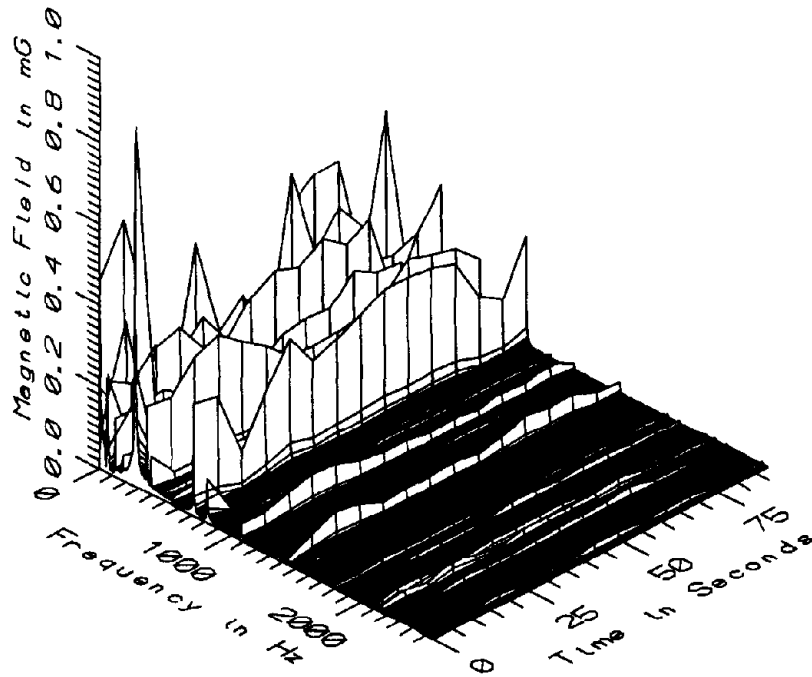

MET032 - 50cm FROM SAFETY LINE, 1M ABOVE PLATFORM, SOUTH BOUND SIDE

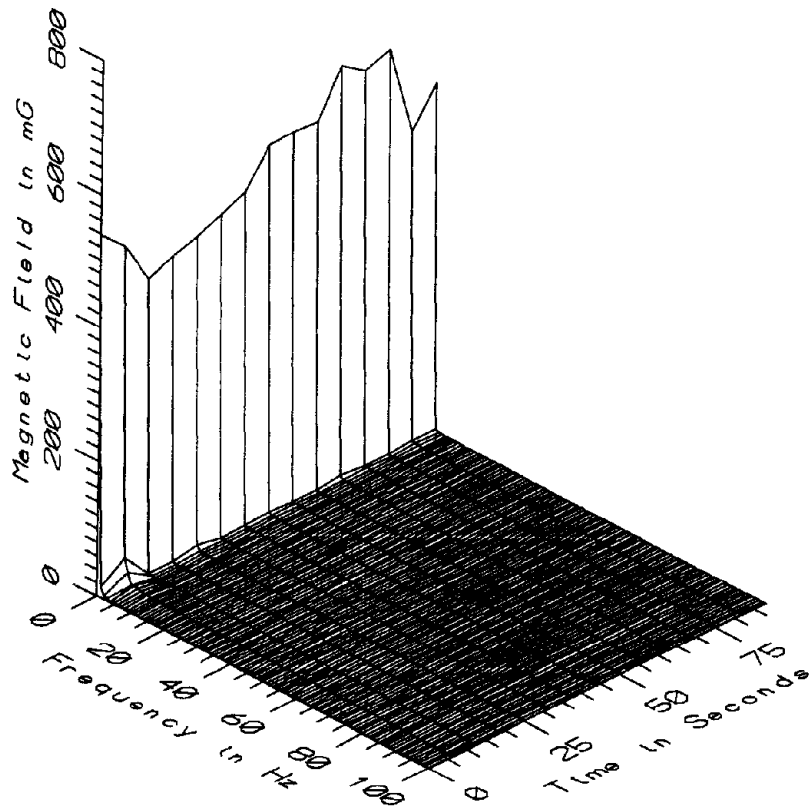

MET032 - 100<sub>cm</sub> FROM SAFETY LINE, 1M ABOVE PLATFORM, SOUTH BOUND SIDE

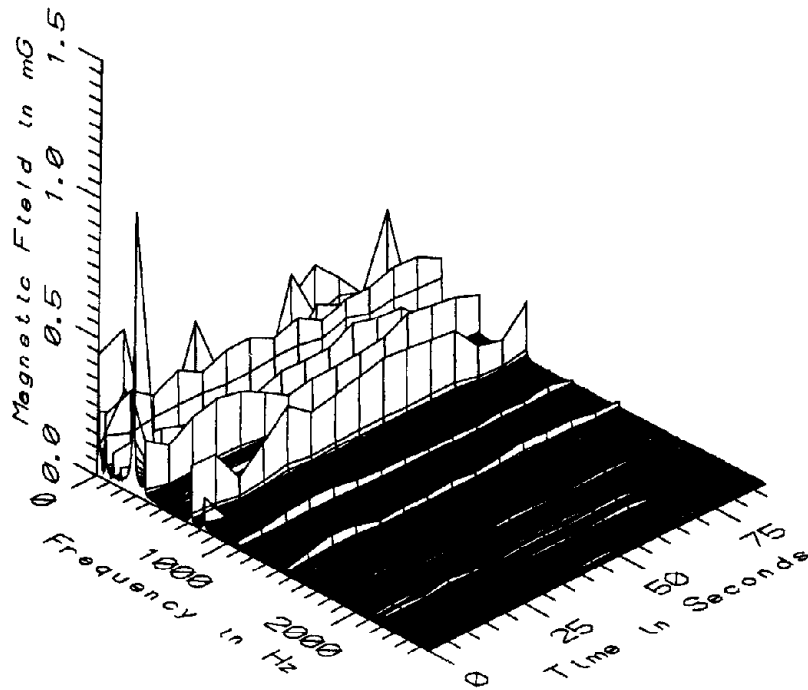

MET032 - 100<sub>cm</sub> FROM SAFETY LINE, 1M ABOVE PLATFORM, SOUTH BOUND SIDE

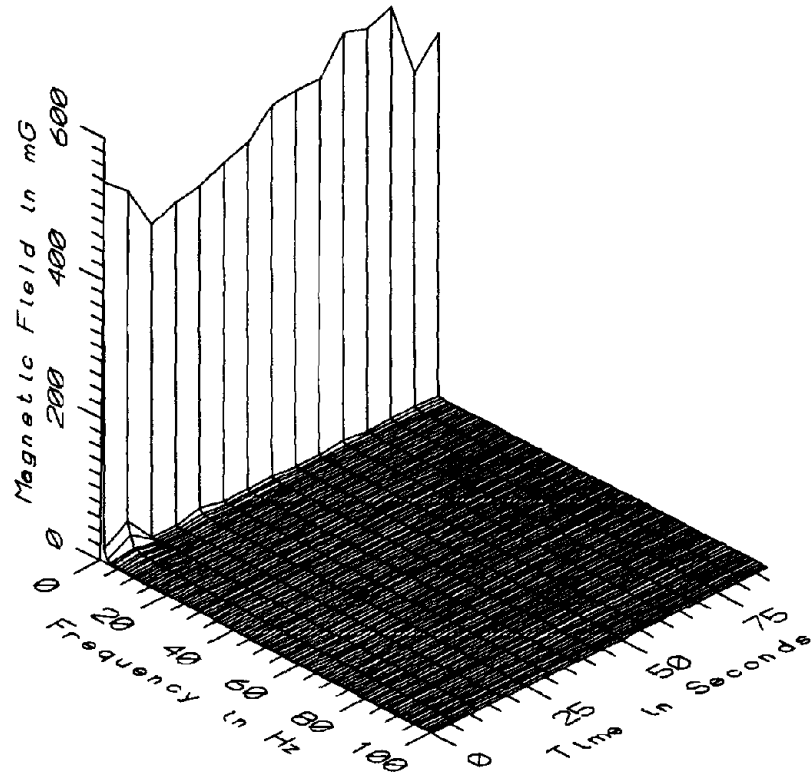

MET032 - 150cm FROM SAFETY LINE, 1M ABOVE PLATFORM, SOUTH BOUND SIDE

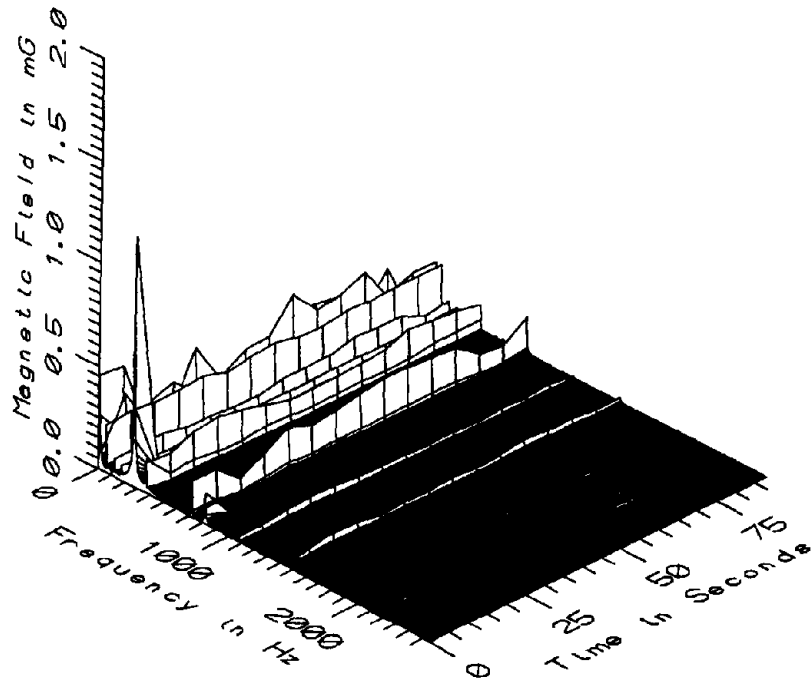

MET032 - 150cm FROM SAFETY LINE, 1M ABOVE PLATFORM, SOUTH BOUND SIDE

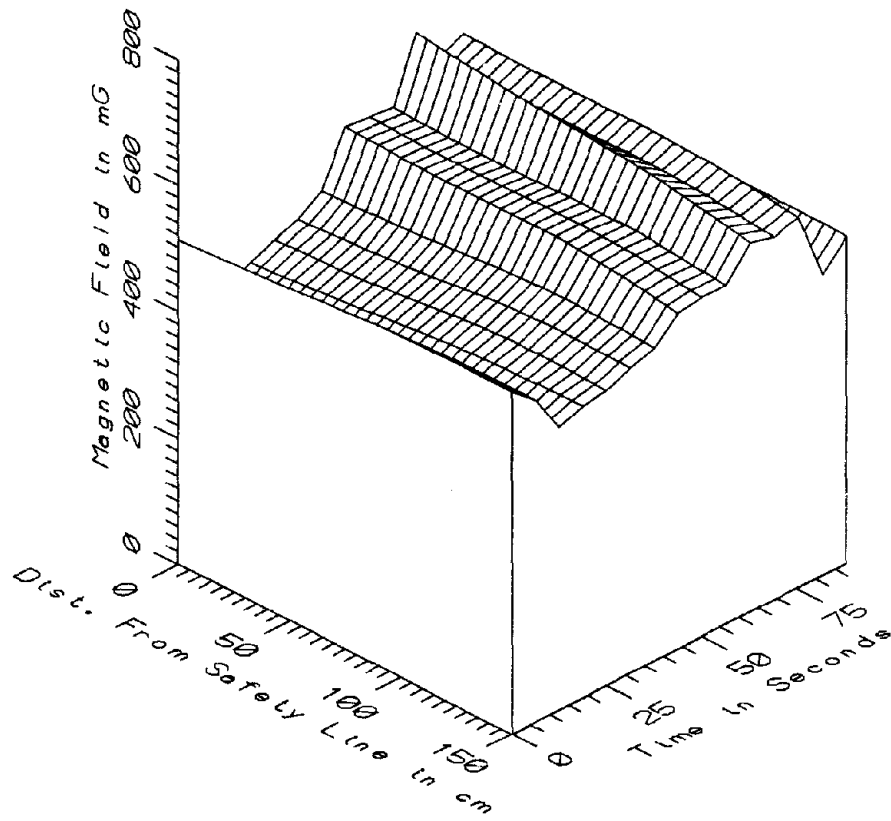

MET032 - 1M ABOVE PLATFORM, SOUTH BOUND SIDE - STATIC

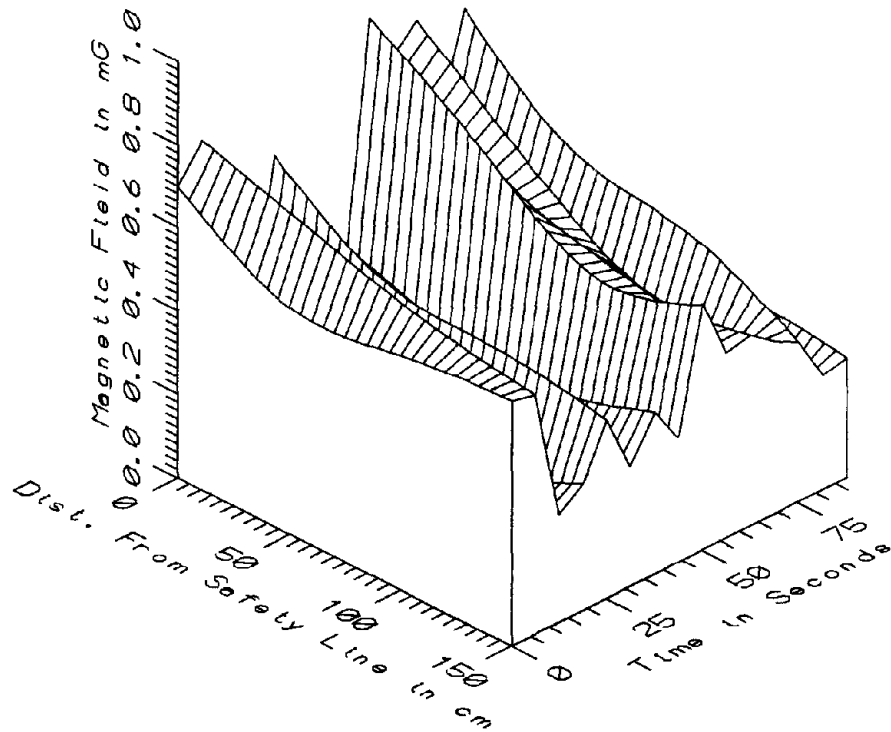

MET032 - 1M ABOVE PLATFORM, SOUTH BOUND SIDE - LOW FREQ, 5-45Hz

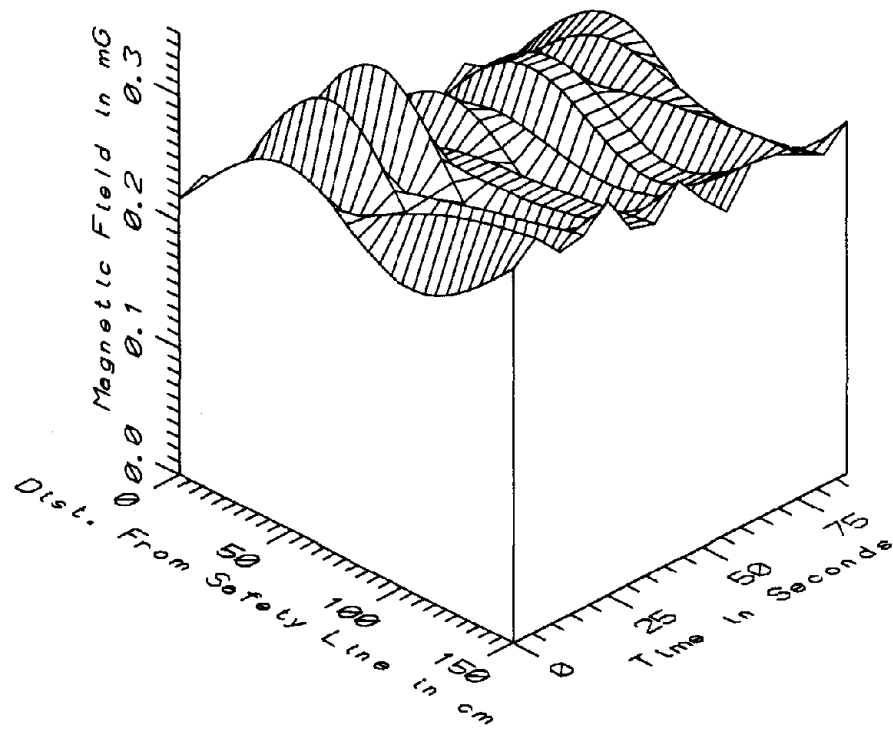

MET032 - 1M ABOVE PLATFORM, SOUTH BOUND SIDE - POWER FREQ, 50-60Hz

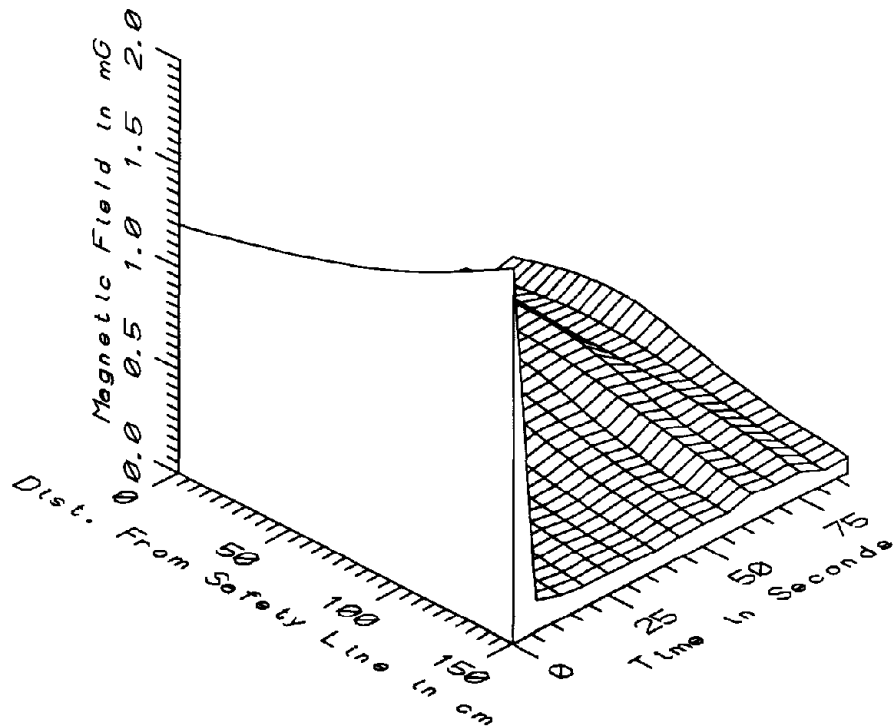

MET032 - 1M ABOVE PLATFORM, SOUTH BOUND SIDE - POWER HARM, 65-300Hz

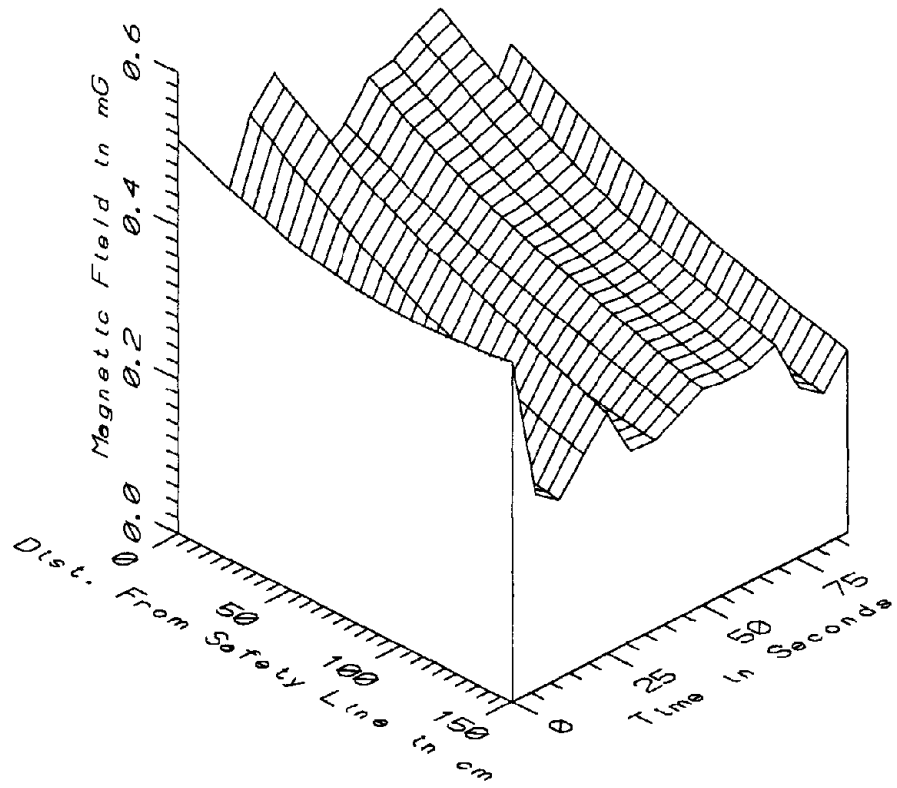

MET032 - 1M ABOVE PLATFORM, SOUTH BOUND SIDE - HIGH FREQ, 305-2560Hz

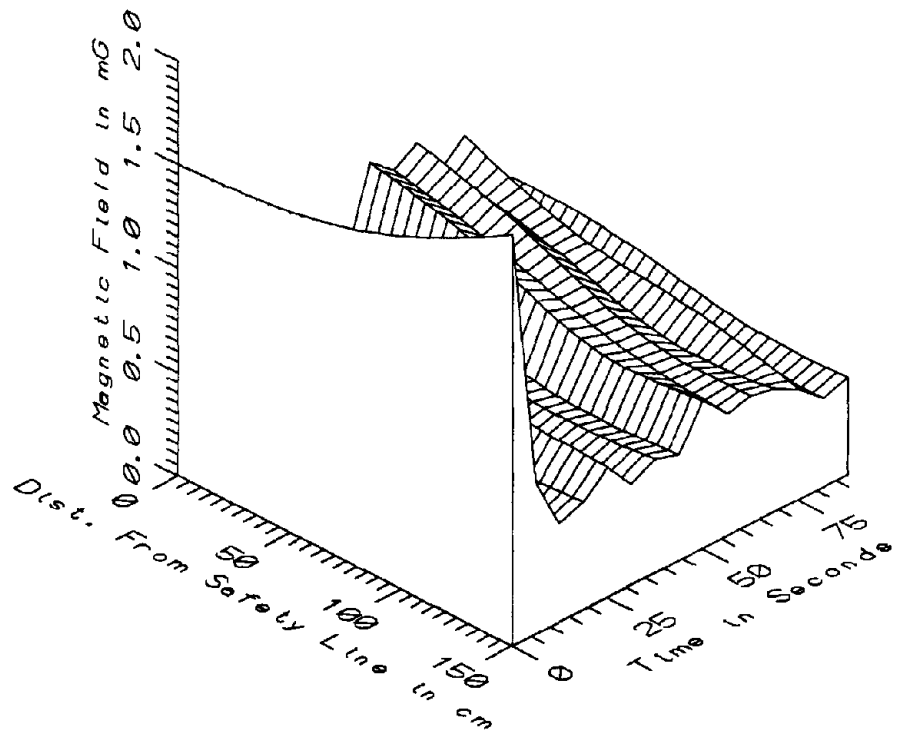

MET032 - 1M ABOVE PLATFORM, SOUTH BOUND SIDE - ALL FREQ, 5-2560Hz

IMET032 - GALLERY PLACE PLATFORM, SOUTH BOUND SIDE		TOTAL OF 15 SAMPLES				
FREQUENCY BAND	DIST FROM LINE (cm)	MINIMUM MAGNETIC FIELD (mG)	MAXIMUM MAGNETIC FIELD (mG)	AVERAGE MAGNETIC FIELD (mG)	STANDARD DEVIATION (mG)	COEFFICIENT OF VARIATION (%)
STATIC	0	400.02	652.89	507.87	77.06	15.17
	50	415.95	630.68	512.51	66.60	13.00
	100	437.19	615.78	522.46	55.98	10.71
	150	445.39	585.30	515.23	44.54	8.65
5-45Hz	0	0.19	0.87	0.53	0.25	47.26
LOW FREQ	50	0.06	0.70	0.39	0.23	58.21
	100	0.17	0.62	0.37	0.15	40.93
	150	0.26	0.59	0.40	0.12	29.18
50-60Hz	0	0.16	0.23	0.20	0.02	8.21
PWR FREQ	50	0.22	0.33	0.27	0.03	10.55
	100	0.20	0.29	0.24	0.02	10.09
	150	0.26	0.31	0.28	0.02	5.69
65-300Hz	0	0.20	1.21	0.33	0.25	74.74
PWR HARM	50	0.24	1.34	0.37	0.27	73.92
	100	0.16	1.53	0.28	0.34	122.05
	150	0.07	1.81	0.22	0.44	200.26
305-2560Hz	0	0.36	0.54	0.45	0.05	11.99
HIGH FREQ	50	0.29	0.45	0.37	0.05	12.78
	100	0.24	0.43	0.31	0.05	15.75
	150	0.20	0.44	0.27	0.06	20.78
5-2560Hz	0	0.50	1.50	0.82	0.26	32.17
ALL FREQ	50	0.47	1.54	0.74	0.26	35.05
	100	0.42	1.70	0.65	0.31	47.71
	150	0.43	1.97	0.65	0.38	57.71





APPENDIX AD

DATASET MET033  
GALLERY PLACE PLATFORM, NORTH BOUND SIDE

Measurement Setup Code:        Staff:    31    Reference: -  
   Drawing:  A-5

Vehicle Status:                    NA

Measurement Date:                May 19, 1992

Measurement Time:                Start:     15:56:28  
   End:        15:57:46

Number of Samples:                11

Programmed Sample Interval:     5 sec

Actual Sample Interval:         7.8 sec

Frequency Spectrum Parameters

<u>Probe Type:</u>	<u>Wideband</u>	<u>Static</u>
Maximum Frequency (Hz)	2560	100
Minimum Frequency (Hz)	5	0
Spectral Bandwidth (Hz)	5	1

Missing Data: No reference probe

Saturated Data: None

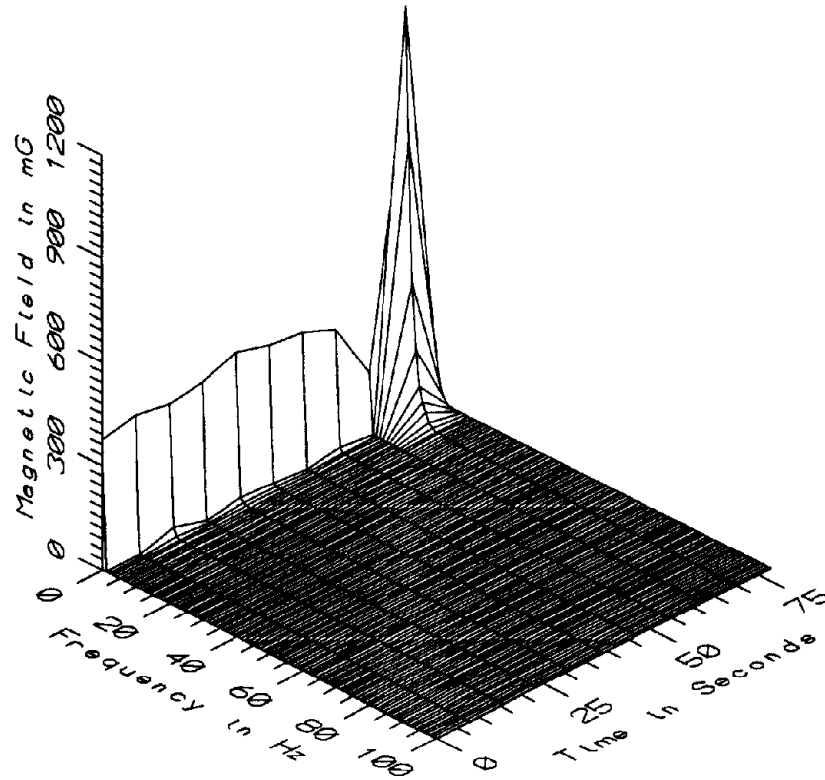

MET033 - 10cm ABOVE PLATFORM AT SAFETY LINE, NORTH BOUND SIDE

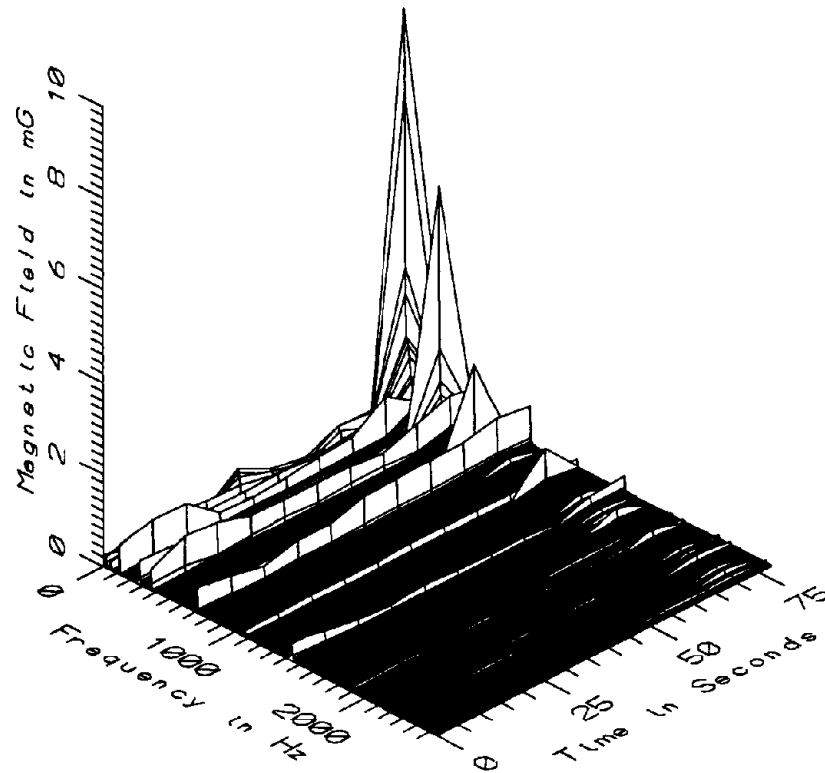

MET033 - 10cm ABOVE PLATFORM AT SAFETY LINE, NORTH BOUND SIDE

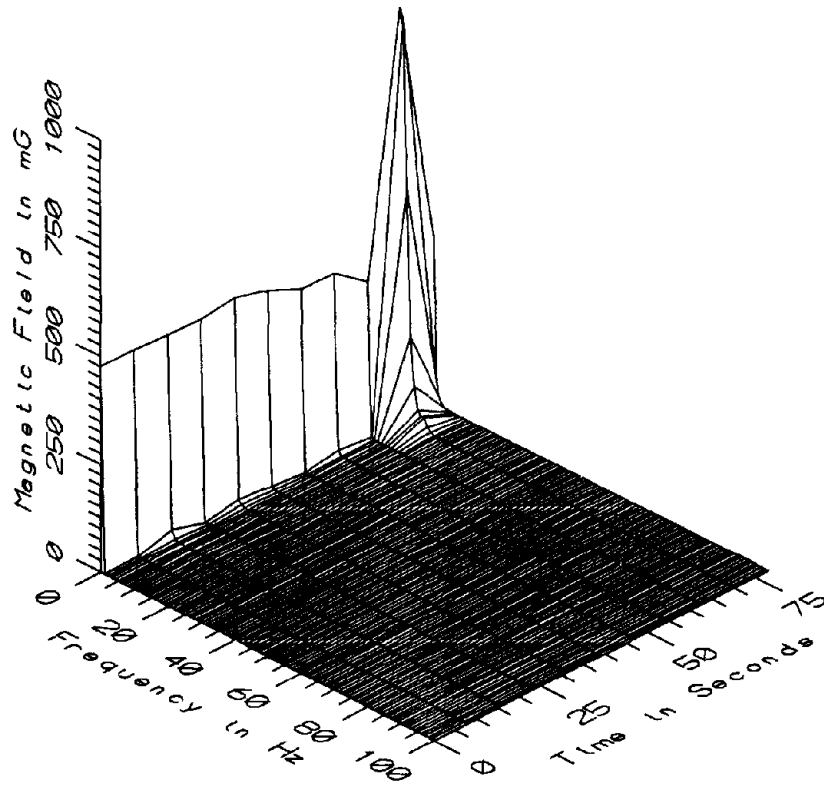

MET033 - 60cm ABOVE PLATFORM AT SAFETY LINE, NORTH BOUND SIDE

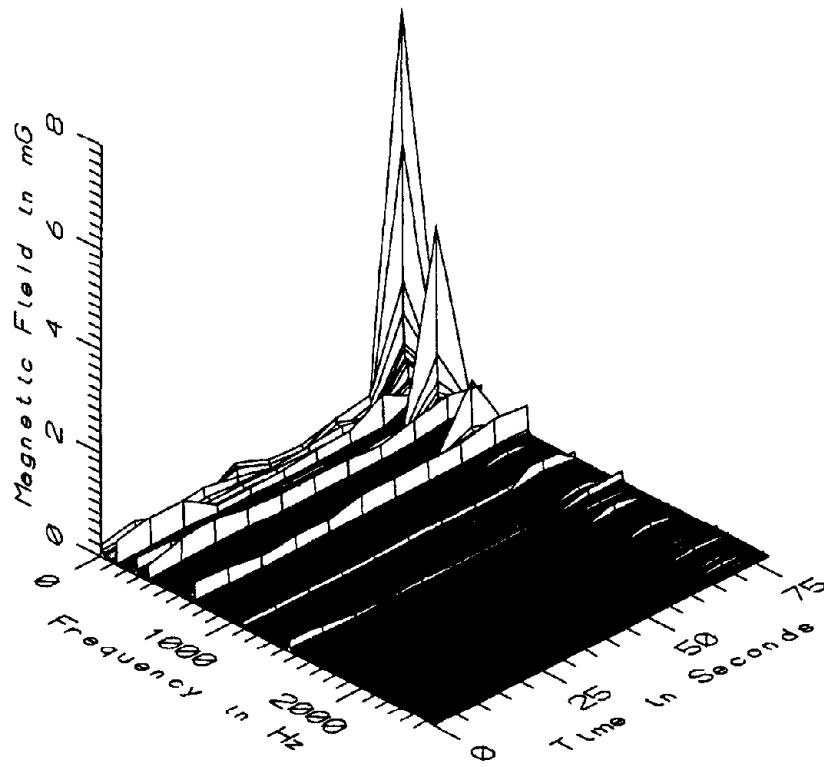

MET033 - 60cm ABOVE PLATFORM AT SAFETY LINE, NORTH BOUND SIDE

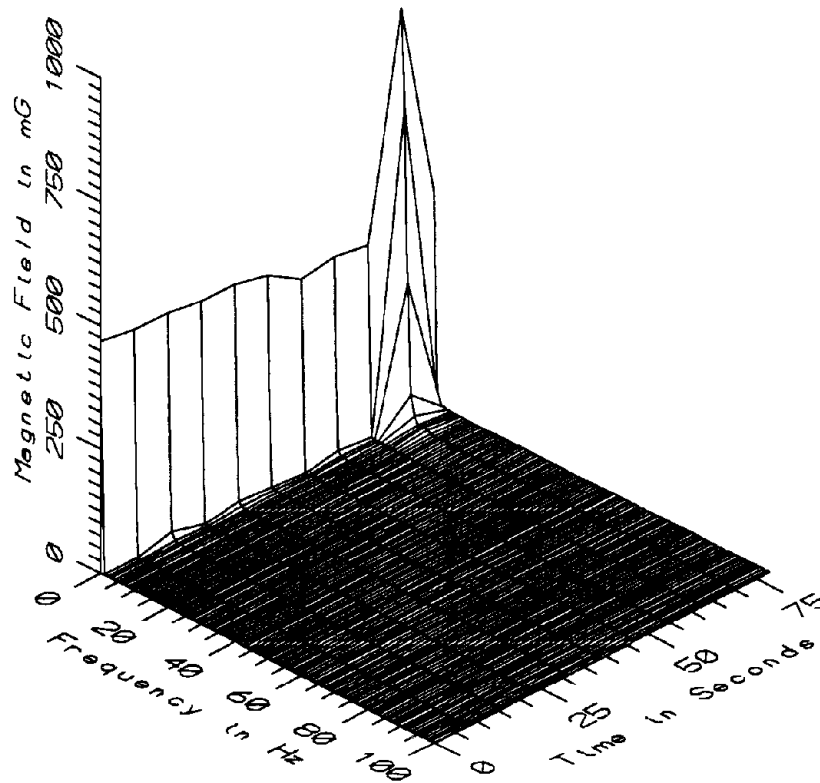

MET033 - 110cm ABOVE PLATFORM AT SAFETY LINE, NORTH BOUND SIDE

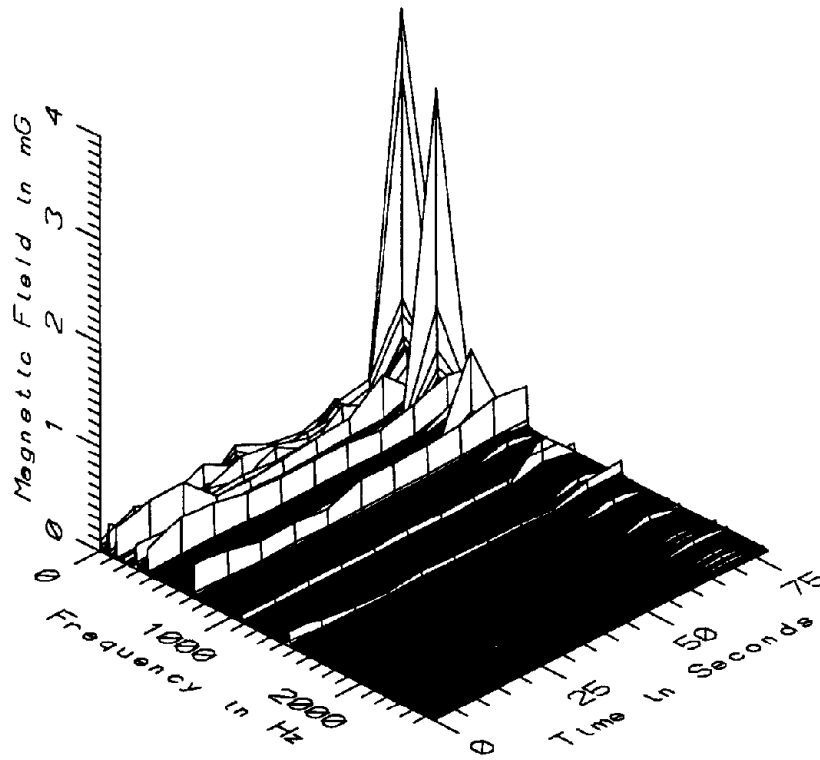

MET033 - 110cm ABOVE PLATFORM AT SAFETY LINE, NORTH BOUND SIDE

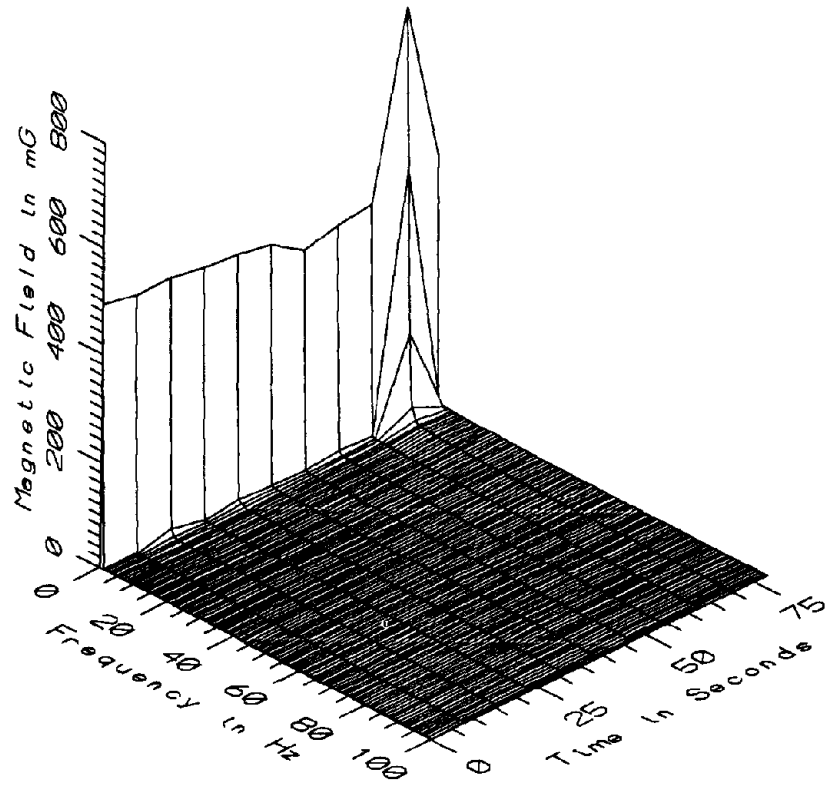

MET033 - 160cm ABOVE PLATFORM AT SAFETY LINE, NORTH BOUND SIDE

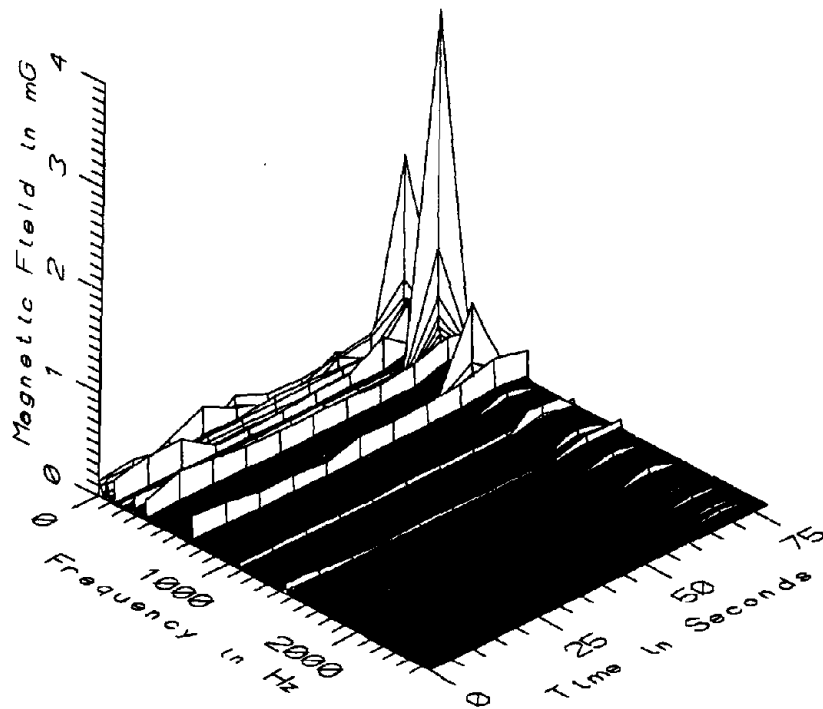

MET033 - 160cm ABOVE PLATFORM AT SAFETY LINE, NORTH BOUND SIDE

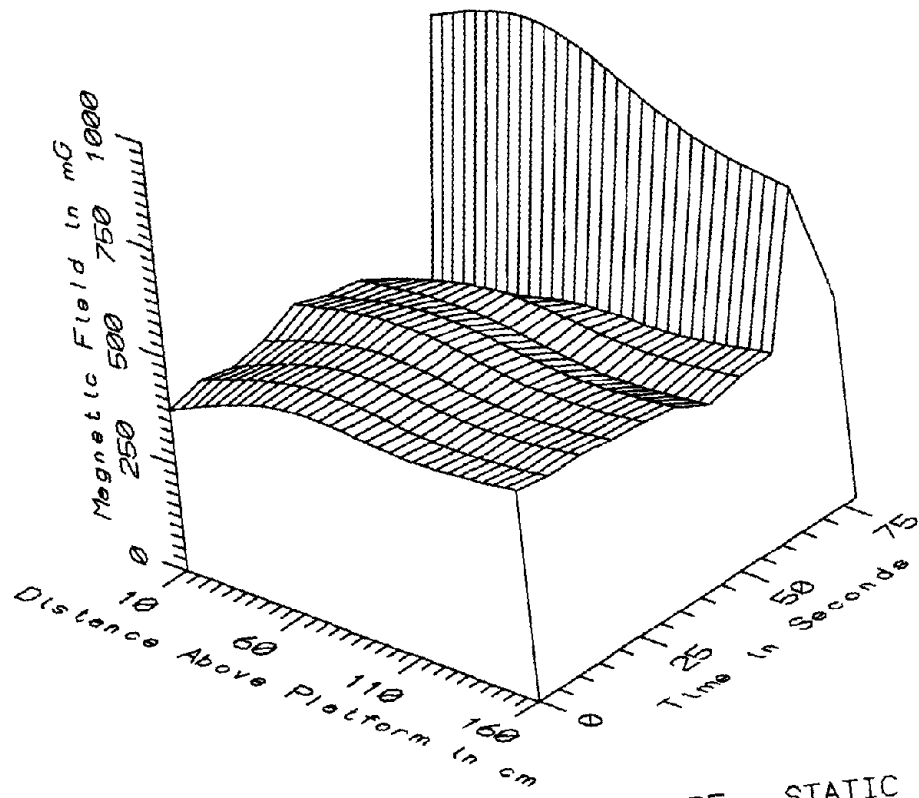

MET033 - AT SAFETY LINE, NORTH BOUND SIDE - STATIC

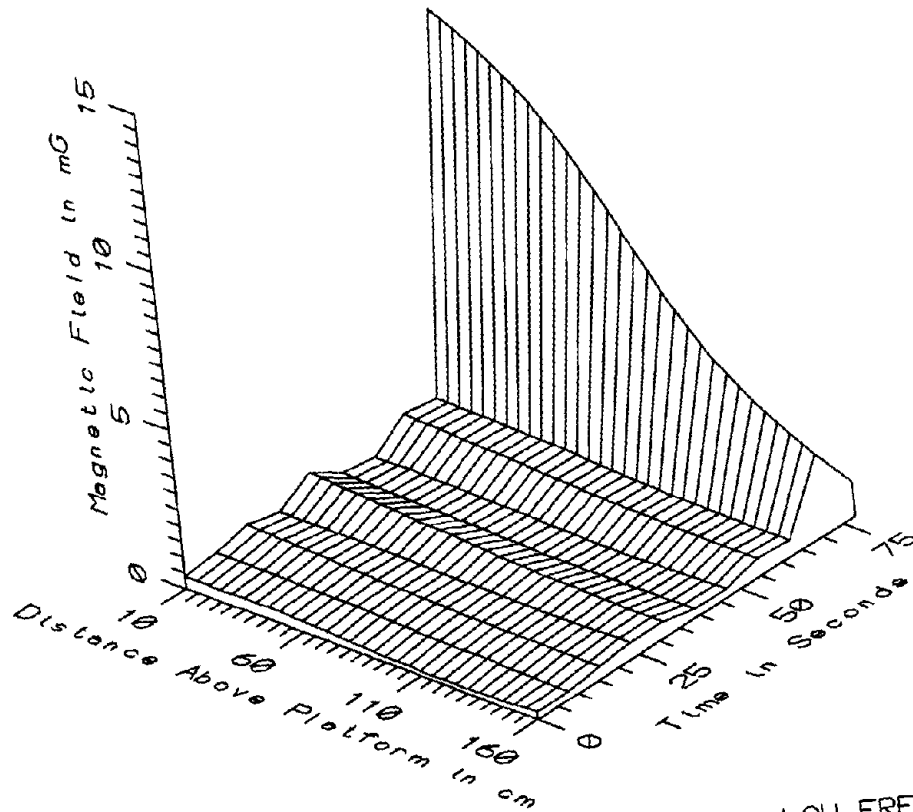

MET033 - AT SAFETY LINE, NORTH BOUND SIDE - LOW FREQ, 5-45Hz

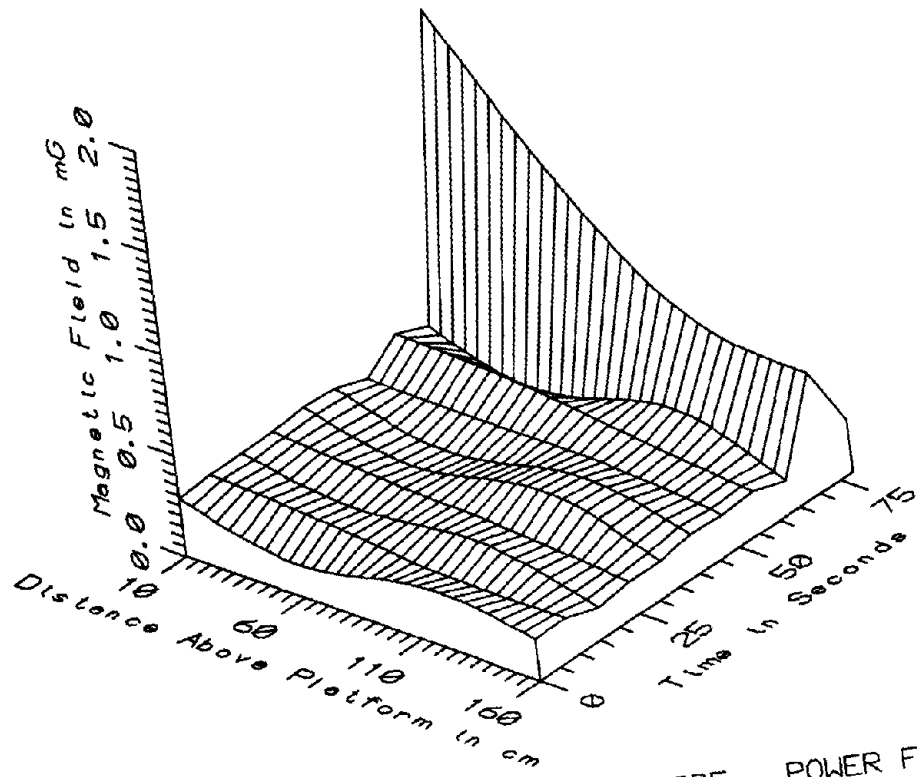

MET033 - AT SAFETY LINE, NORTH BOUND SIDE - POWER FREQ. 50-60Hz

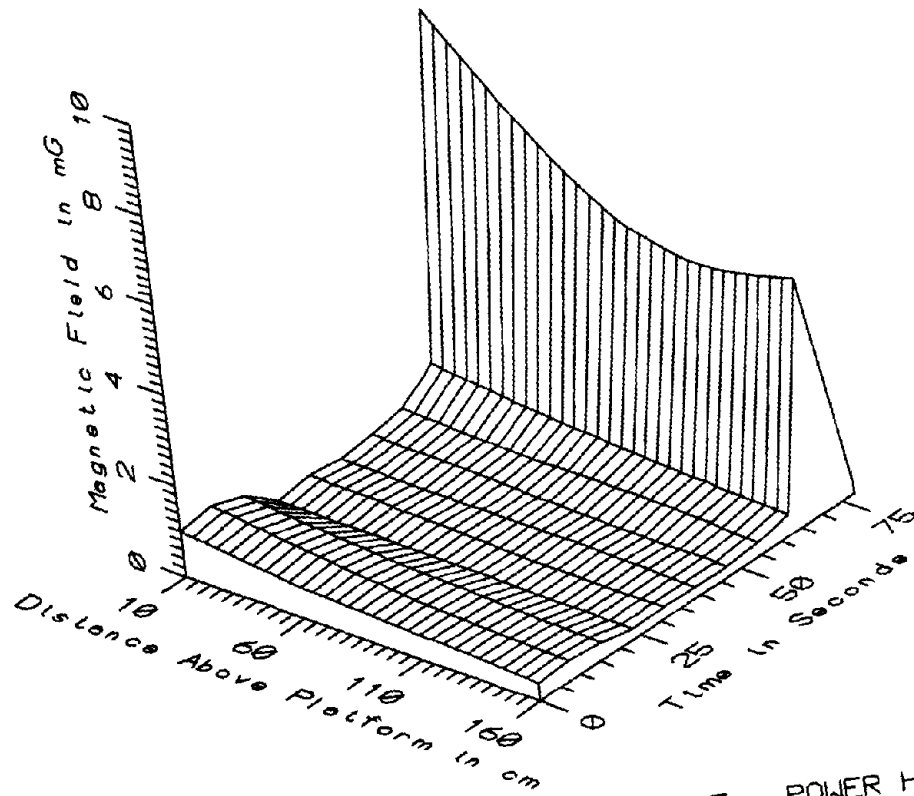

MET033 - AT SAFETY LINE, NORTH BOUND SIDE - POWER HARM. 65-300Hz

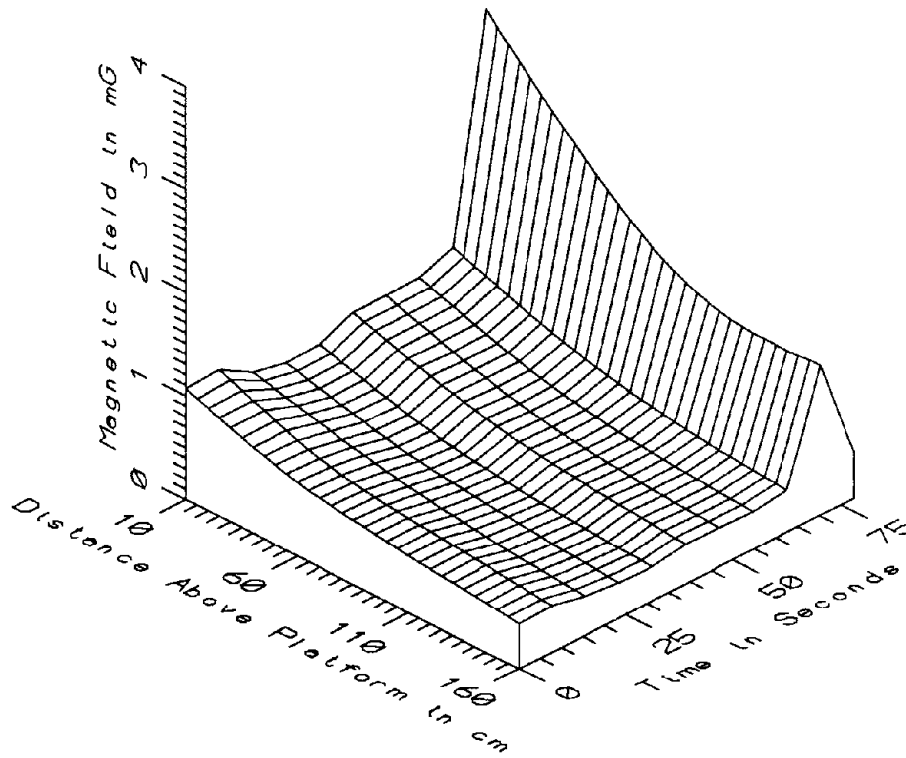

MET033 - AT SAFETY LINE, NORTH BOUND SIDE - HIGH FREQ, 305-2560Hz

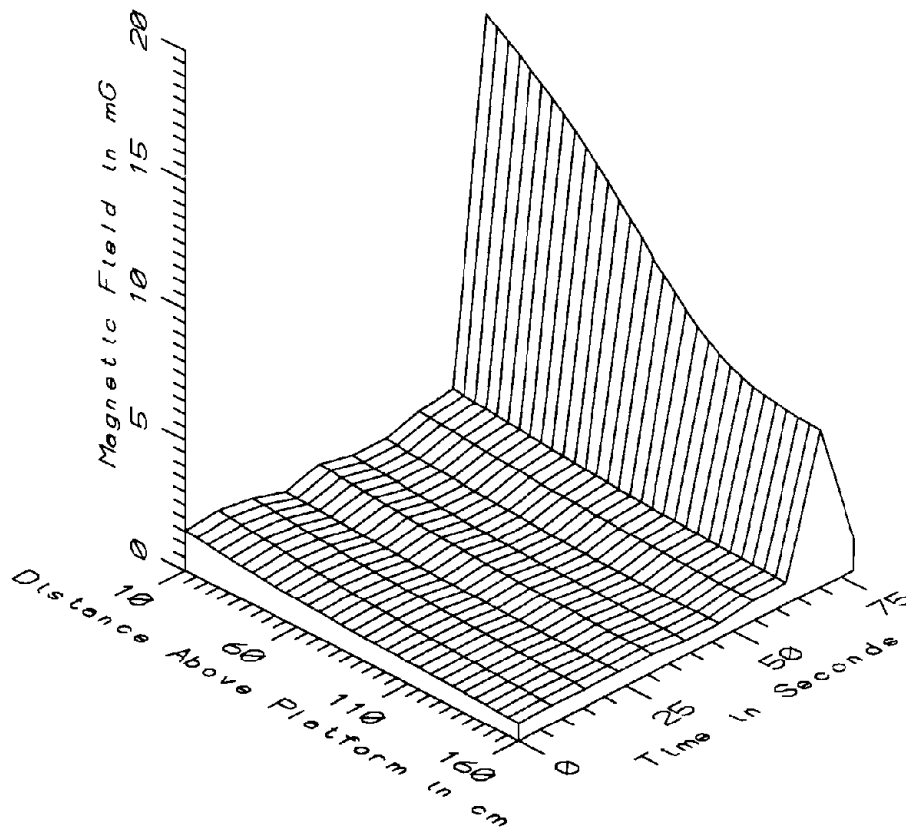

MET033 - AT SAFETY LINE, NORTH BOUND SIDE - ALL FREQ, 5-2560Hz



MET033 - GALLERY PLACE PLATFORM, NORTH BOUND SIDE							TOTAL OF 101 SAMPLES	
FREQUENCY BAND	HEIGHT ABOVE FLOOR (cm)	MINIMUM MAGNETIC FIELD (mG)	MAXIMUM MAGNETIC FIELD (mG)	AVERAGE MAGNETIC FIELD (mG)	STANDARD DEVIATION (mG)	COEFFICIENT OF VARIATION (%)		
STATIC	10	165.35	874.66	395.61	182.65	46.17		
	60	360.46	952.79	488.25	159.30	32.63		
	110	389.32	833.28	467.95	124.35	26.57		
	160	410.11	775.02	486.88	98.84	20.30		
5-45HZ LOW FREQ	10	0.30	12.53	1.87	3.58	191.91		
	60	0.27	9.97	1.49	2.83	190.37		
	110	0.15	5.21	0.91	1.46	160.11		
	160	0.24	2.61	0.67	0.69	103.30		
50-60HZ PWR FREQ	10	0.27	1.77	0.45	0.44	97.90		
	60	0.16	1.13	0.32	0.28	87.21		
	110	0.20	0.68	0.31	0.13	41.12		
	160	0.15	0.59	0.23	0.12	52.70		
65-300HZ PWR HARM	10	0.28	8.41	1.34	2.37	177.05		
	60	0.26	6.06	0.98	1.70	172.72		
	110	0.24	4.80	0.79	1.34	168.21		
	160	0.23	5.21	0.76	1.48	193.43		
305-2560HZ HIGH FREQ	10	0.83	3.27	1.22	0.69	56.97		
	60	0.55	2.21	0.82	0.47	57.60		
	110	0.40	1.51	0.59	0.31	53.17		
	160	0.33	1.45	0.49	0.32	66.15		
5-2560HZ ALL FREQ	10	1.05	15.54	2.82	4.24	150.71		
	60	0.81	11.92	2.10	3.27	155.89		
	110	0.61	7.28	1.46	1.94	133.14		
	160	0.56	6.03	1.22	1.60	131.27		



APPENDIX AE

DATASET MET034  
GALLERY PLACE PLATFORM, NORTH BOUND SIDE

Measurement Setup Code:        Staff:    33    Reference: -  
   Drawing:  A-5

Vehicle Status:                NA

Measurement Date:              May 19, 1992

Measurement Time:              Start:    15:59:29  
   End:      16:01:08

Number of Samples:             16

Programmed Sample Interval:    5 sec

Actual Sample Interval:        6.6 sec

Frequency Spectrum Parameters

<u>Probe Type:</u>	<u>Wideband</u>	<u>Static</u>
Maximum Frequency (Hz)	2560	100
Minimum Frequency (Hz)	5	0
Spectral Bandwidth (Hz)	5	1

Missing Data: No reference probe

Saturated Data: None

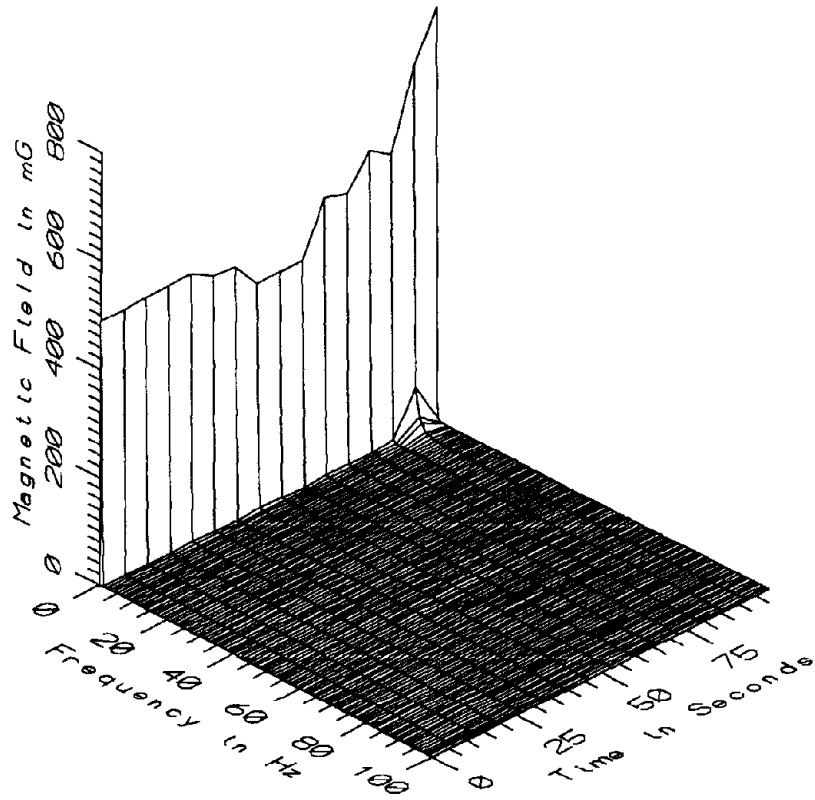

MET034 - 0cm FROM SAFETY LINE, 1M ABOVE PLATFORM, NORTH BOUND SIDE

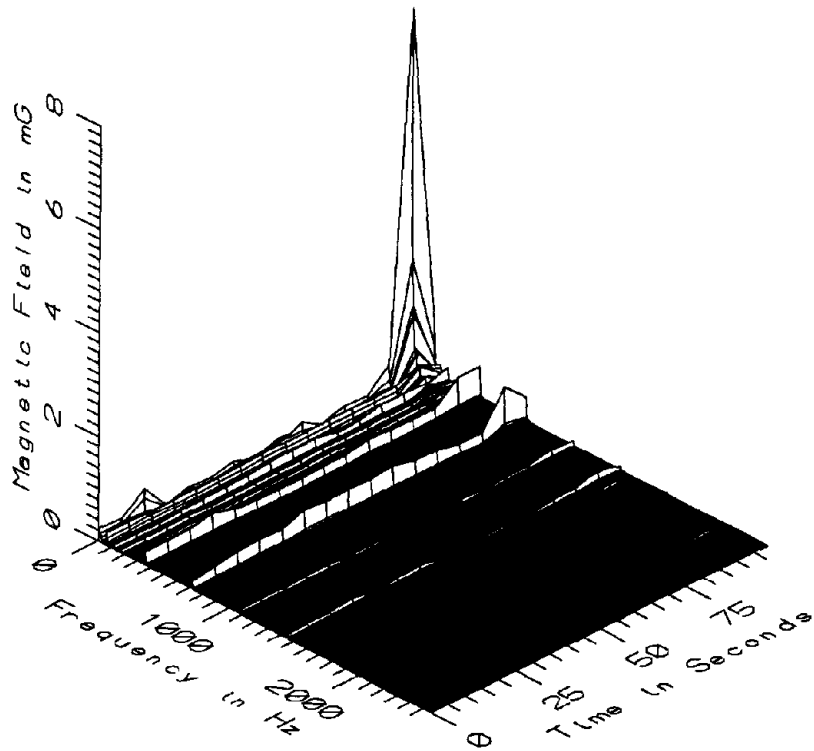

MET034 - 0cm FROM SAFETY LINE, 1M ABOVE PLATFORM, NORTH BOUND SIDE

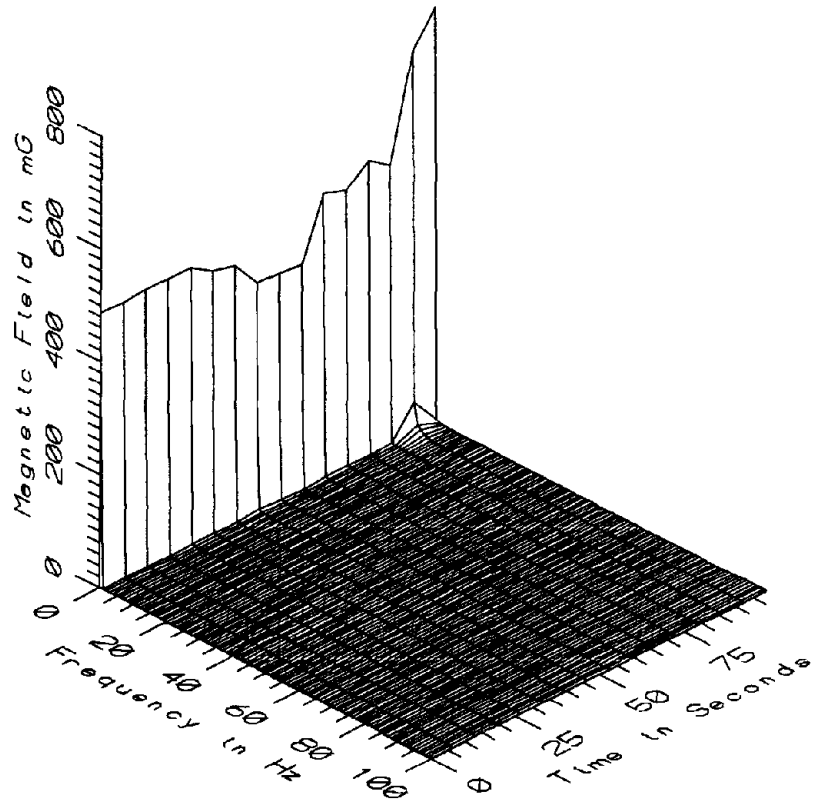

MET034 - 50cm FROM SAFETY LINE, 1M ABOVE PLATFORM, NORTH BOUND SIDE

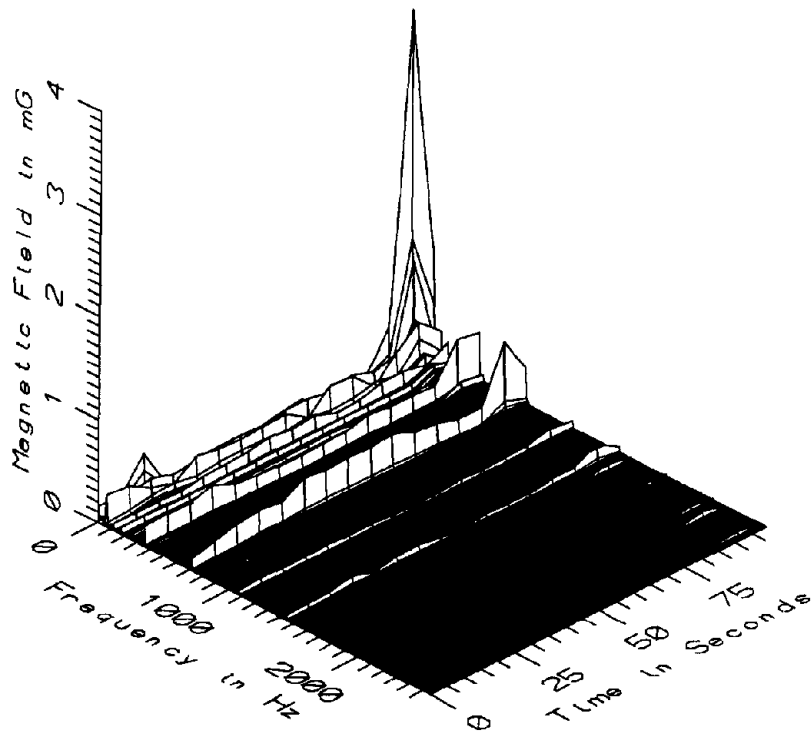

MET034 - 50cm FROM SAFETY LINE, 1M ABOVE PLATFORM, NORTH BOUND SIDE

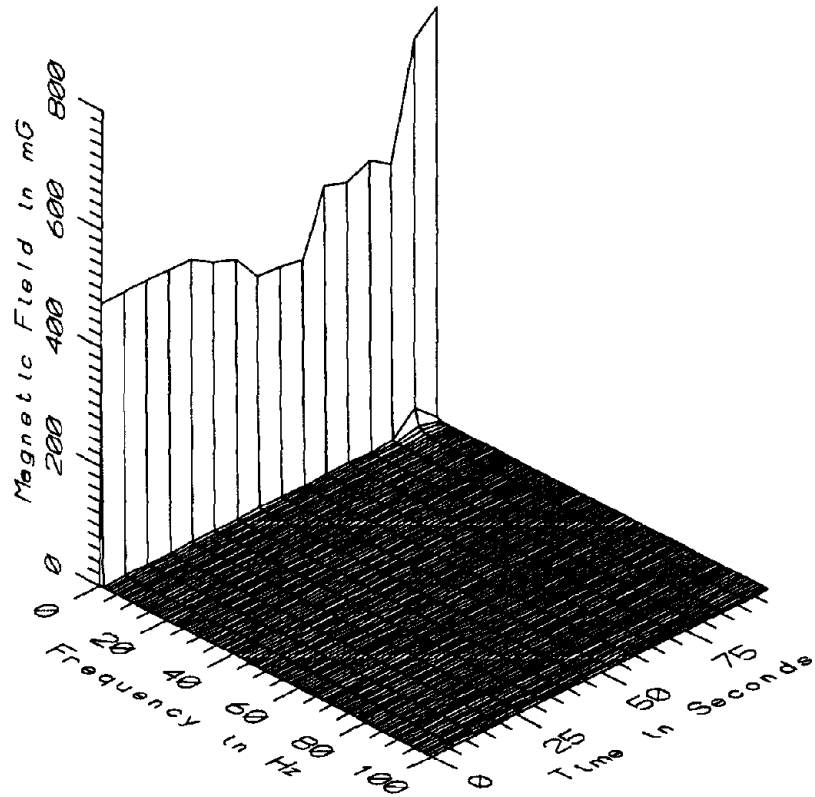

MET034 - 100cm FROM SAFETY LINE, 1M ABOVE PLATFORM, NORTH BOUND SIDE

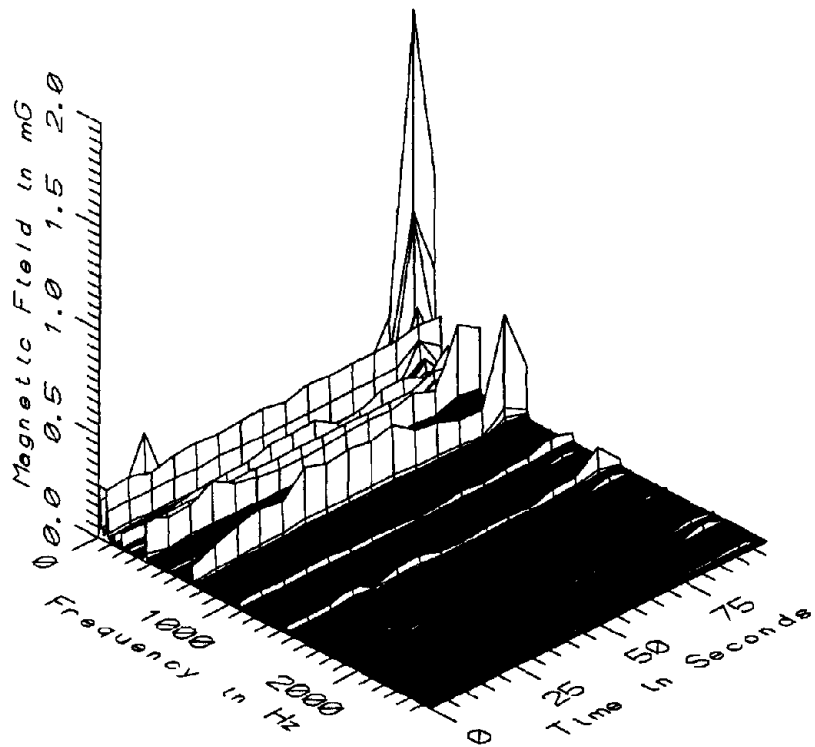

MET034 - 100cm FROM SAFETY LINE, 1M ABOVE PLATFORM, NORTH BOUND SIDE

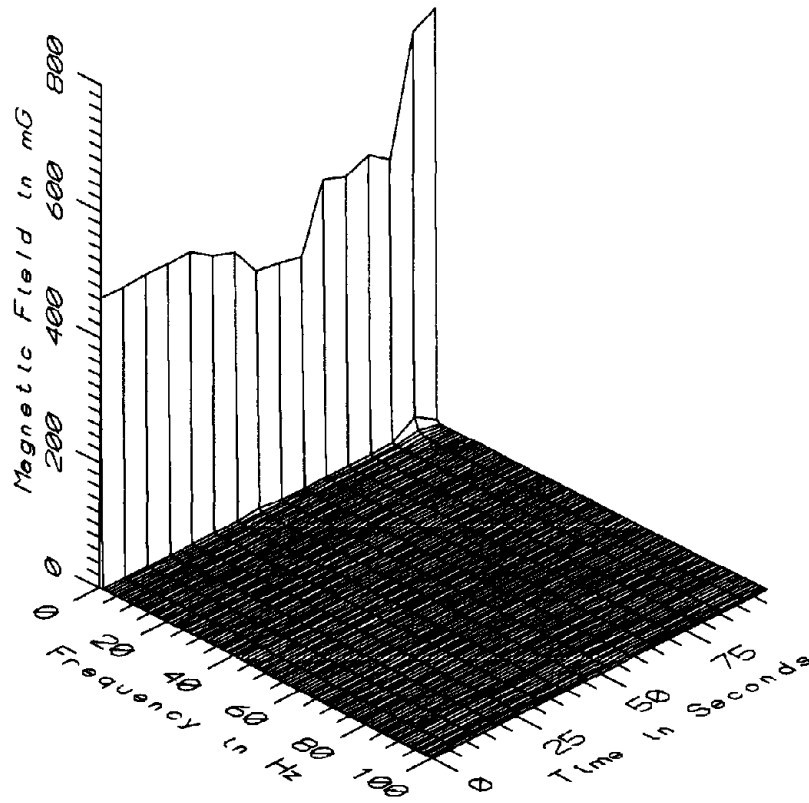

MET034 - 150cm FROM SAFETY LINE, 1M ABOVE PLATFORM, NORTH BOUND SIDE

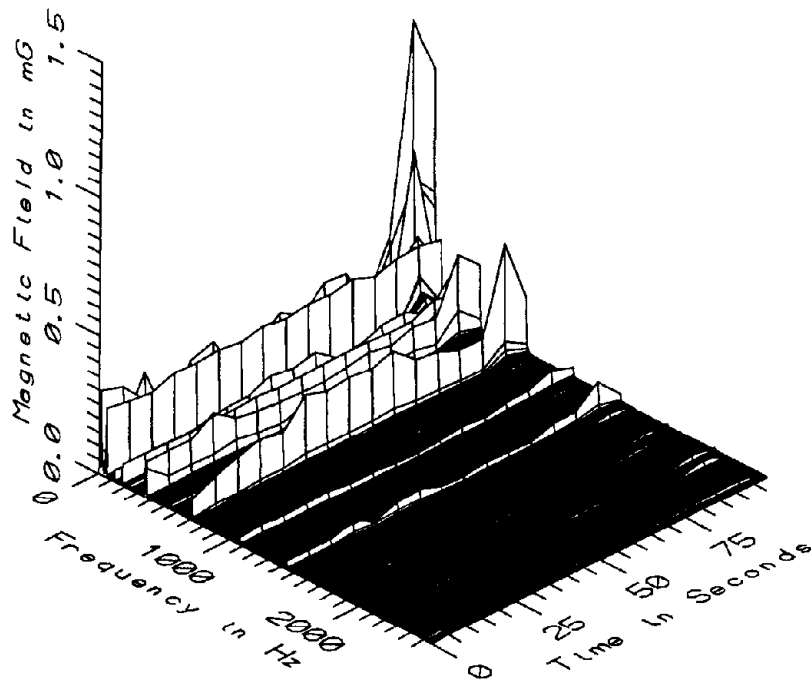

MET034 - 150cm FROM SAFETY LINE, 1M ABOVE PLATFORM, NORTH BOUND SIDE

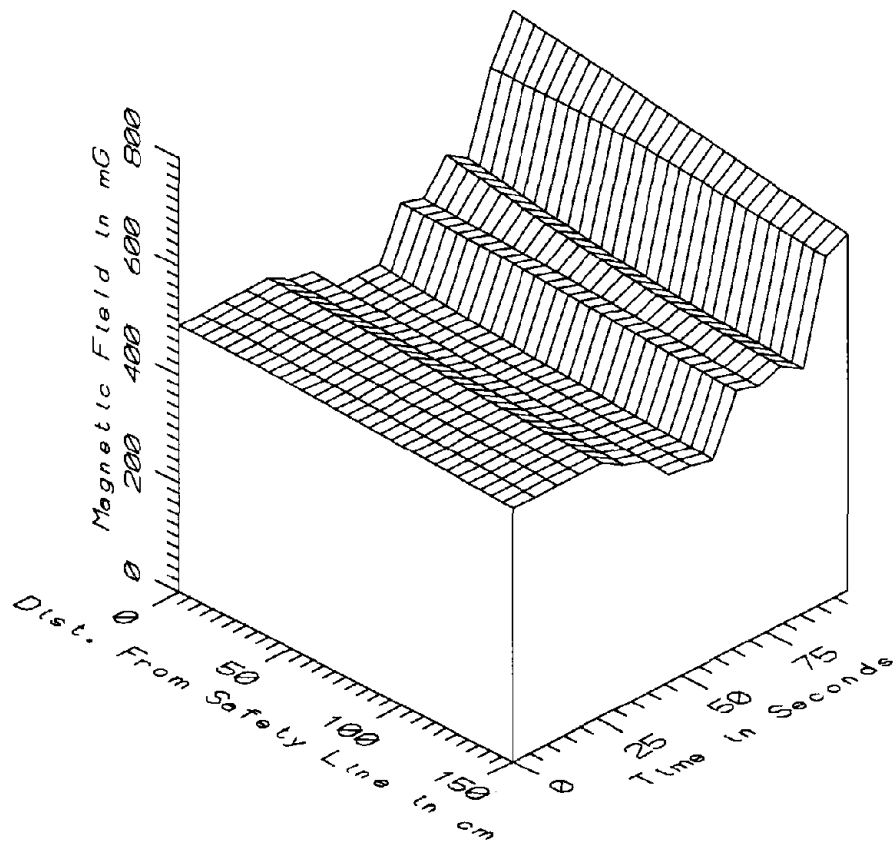

MET034 - 1M ABOVE PLATFORM, NORTH BOUND SIDE - STATIC

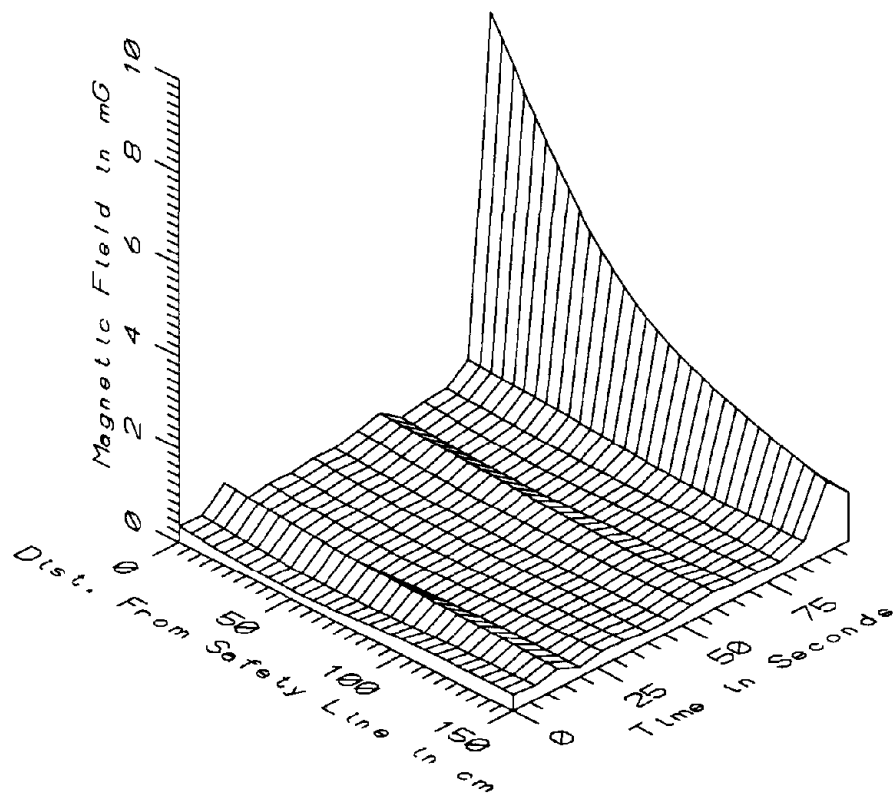

MET034 - 1M ABOVE PLATFORM, NORTH BOUND SIDE - LOW FREQ, 5-45Hz



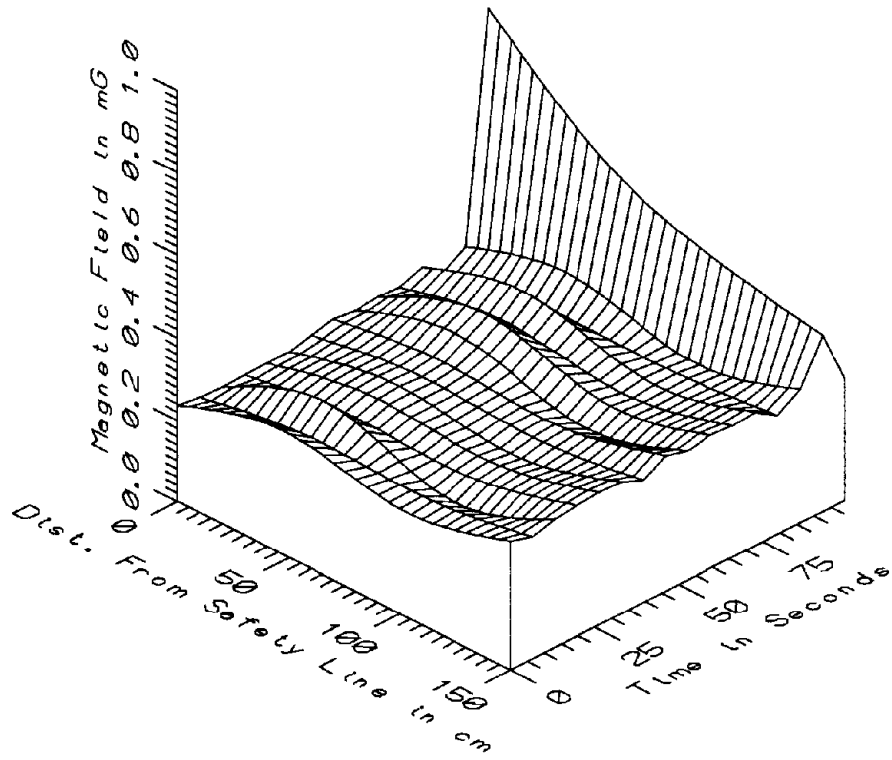

MET034 - 1M ABOVE PLATFORM, NORTH BOUND SIDE - POWER FREQ, 50-60Hz

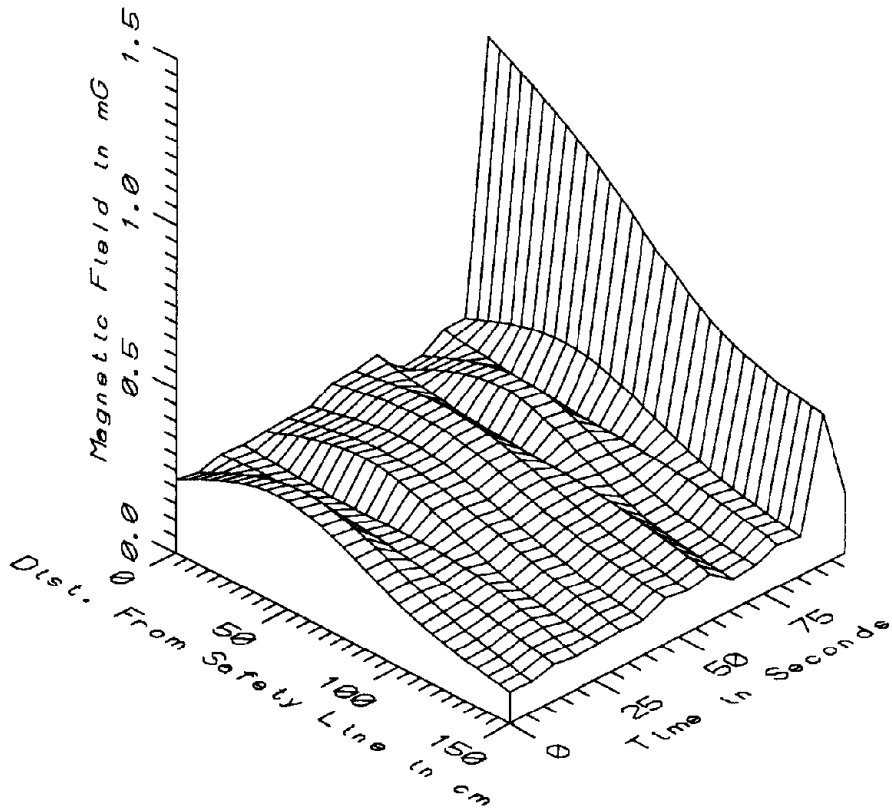

MET034 - 1M ABOVE PLATFORM, NORTH BOUND SIDE - POWER HARM, 65-300Hz

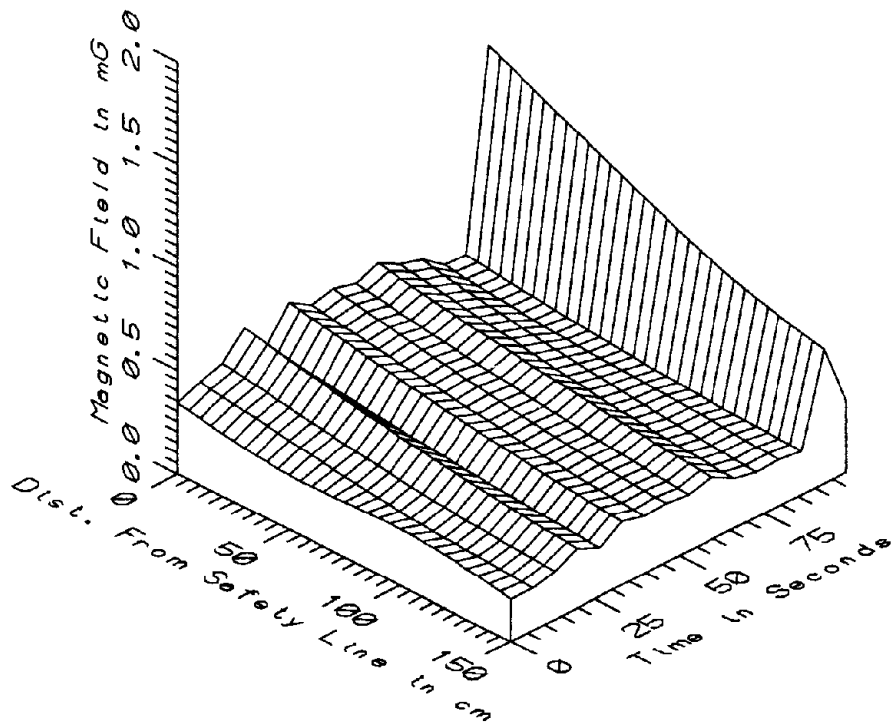

MET034 - 1M ABOVE PLATFORM, NORTH BOUND SIDE - HIGH FREQ, 305-2560Hz

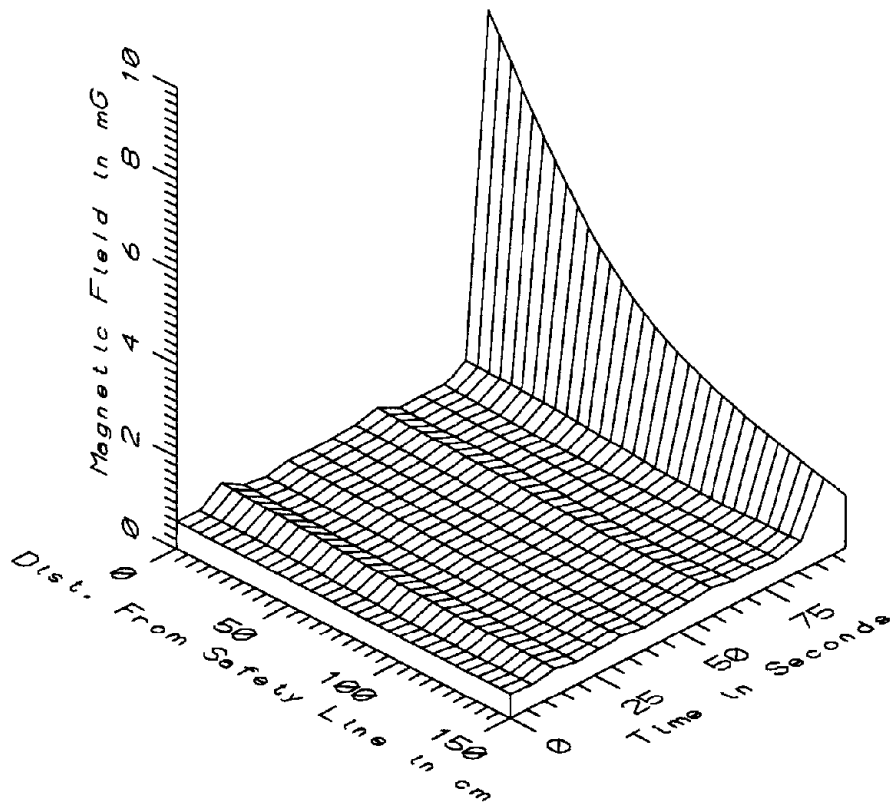

MET034 - 1M ABOVE PLATFORM, NORTH BOUND SIDE - ALL FREQ, 5-2560Hz

MET034 - GALLERY PLACE PLATFORM, NORTH BOUND SIDE		TOTAL OF 16 SAMPLES				
FREQUENCY BAND	DIST FROM LINE (cm)	MINIMUM MAGNETIC FIELD (mG)	MAXIMUM MAGNETIC FIELD (mG)	AVERAGE MAGNETIC FIELD (mG)	STANDARD DEVIATION (mG)	COEFFICIENT OF VARIATION (%)
STATIC	0	414.31	762.19	510.76	91.52	17.92
	50	394.79	730.03	496.88	89.40	17.99
	100	379.77	693.58	480.98	84.83	17.64
	150	366.89	656.77	466.23	78.93	16.93
5-45Hz LOW FREQ	0	0.20	8.03	0.92	1.92	208.65
	50	0.10	4.07	0.55	0.97	176.18
	100	0.19	2.31	0.46	0.54	116.62
50-60Hz PWR FREQ	150	0.22	1.51	0.45	0.34	76.05
	0	0.23	0.82	0.28	0.14	51.67
	50	0.26	0.60	0.32	0.08	25.08
65-300Hz PWR HARM	100	0.23	0.49	0.28	0.06	20.88
	150	0.29	0.43	0.32	0.03	9.89
	0	0.21	1.09	0.31	0.21	69.16
305-2560Hz HIGH FREQ	50	0.20	0.87	0.33	0.15	46.09
	100	0.17	0.57	0.22	0.10	43.83
	150	0.09	0.46	0.14	0.09	64.69
5-2560Hz ALL FREQ	0	0.34	1.31	0.52	0.24	45.65
	50	0.27	1.06	0.42	0.19	45.13
	100	0.24	0.81	0.34	0.14	39.74
150	0.20	0.65	0.28	0.11	37.53	
	0	0.58	8.25	1.23	1.89	153.80
	50	0.53	4.33	0.91	0.94	103.60
100	0.47	2.56	0.70	0.53	74.81	
	0.49	1.76	0.65	0.34	51.60	



**APPENDIX AF**  
**DATASET MET035**  
**ON MEZZANINE AT GALLERY PLACE STATION**

Measurement Setup Code:            Staff:     34    Reference:   -  
   Drawing:   A-5

Vehicle Status:                    NA

Measurement Date:                May 19, 1992

Measurement Time:                Start:     16:04:58  
   End:        16:05:24

Number of Samples:                4

Programmed Sample Interval:     5 sec

Actual Sample Interval:         8.7 sec

**Frequency Spectrum Parameters**

<u>Probe Type:</u>	<u>Wideband</u>	<u>Static</u>
Maximum Frequency (Hz)	2560	100
Minimum Frequency (Hz)	5	0
Spectral Bandwidth (Hz)	5	1

Missing Data: No reference probe

Saturated Data: None

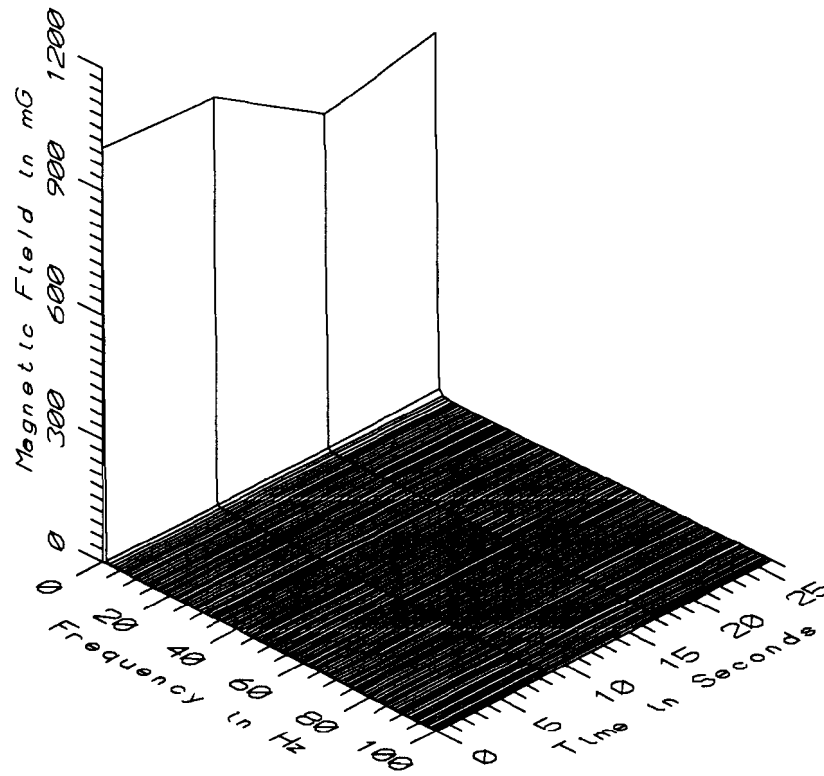

MET035 - 10cm ABOVE FLOOR OF MEZZANINE AT GALLERY PLACE

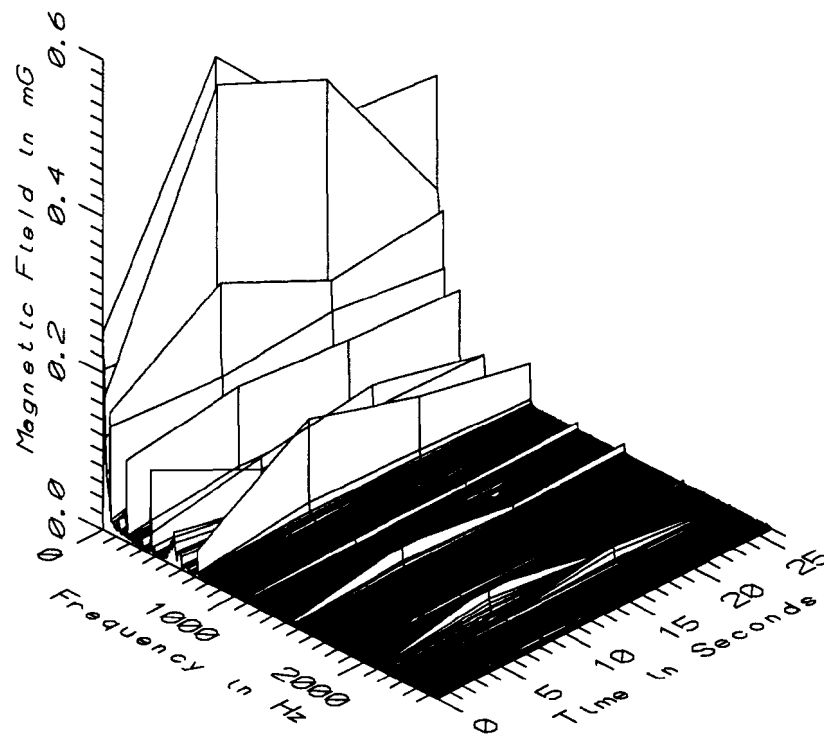

MET035 - 10cm ABOVE FLOOR OF MEZZANINE AT GALLERY PLACE

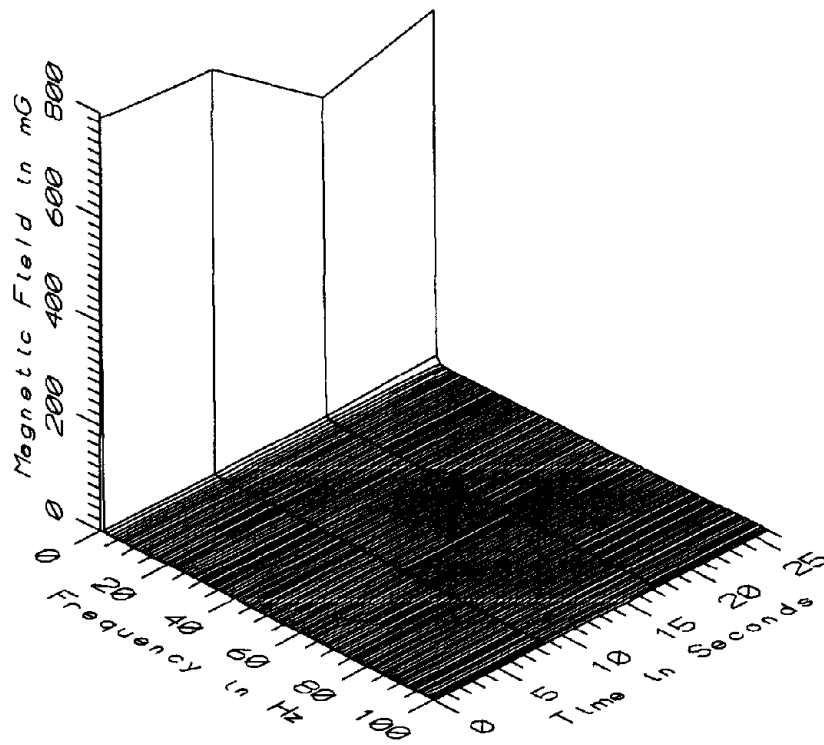

MET035 - 60cm ABOVE FLOOR OF MEZZANINE AT GALLERY PLACE

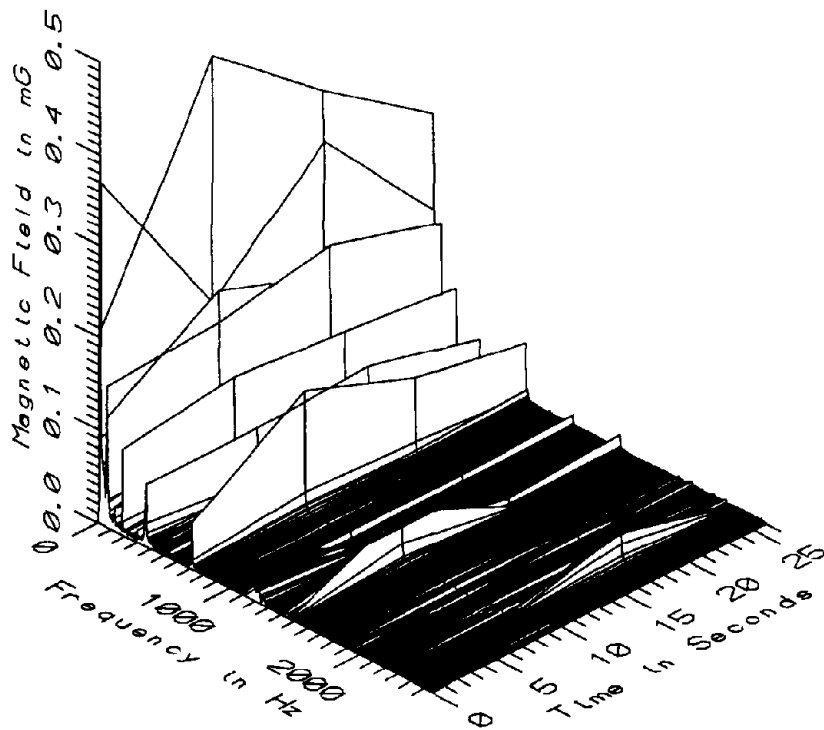

MET035 - 60cm ABOVE FLOOR OF MEZZANINE AT GALLERY PLACE

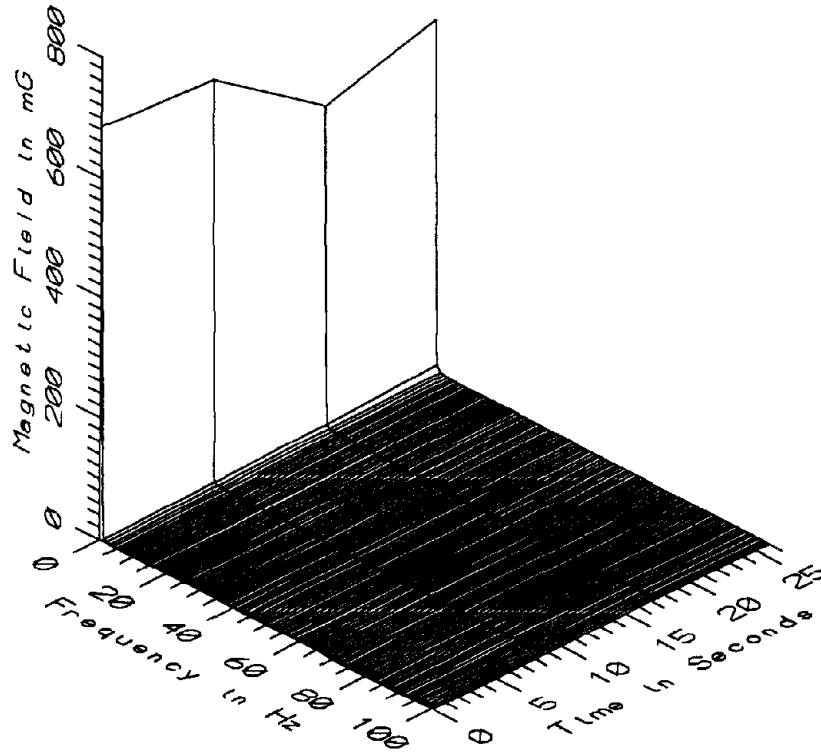

MET035 - 110cm ABOVE FLOOR OF MEZZANINE AT GALLERY PLACE

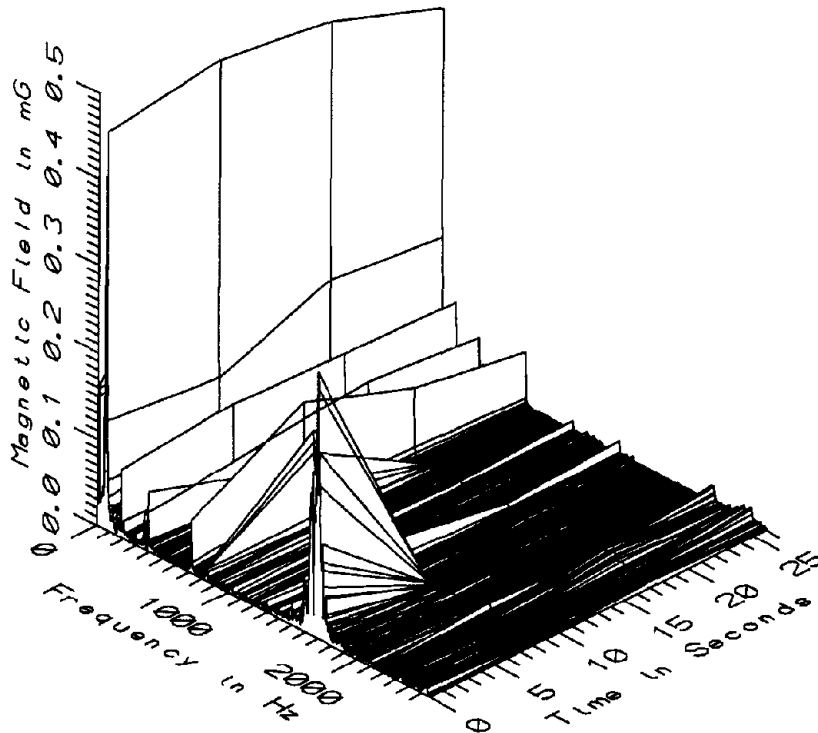

MET035 - 110cm ABOVE FLOOR OF MEZZANINE AT GALLERY PLACE



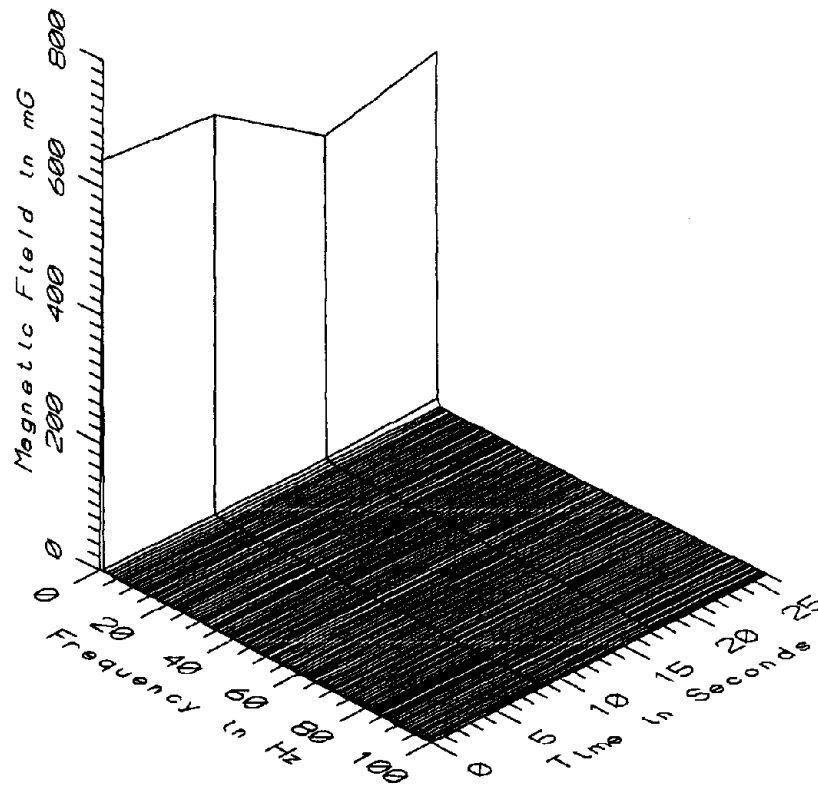

MET035 - 160cm ABOVE FLOOR OF MEZZANINE AT GALLERY PLACE

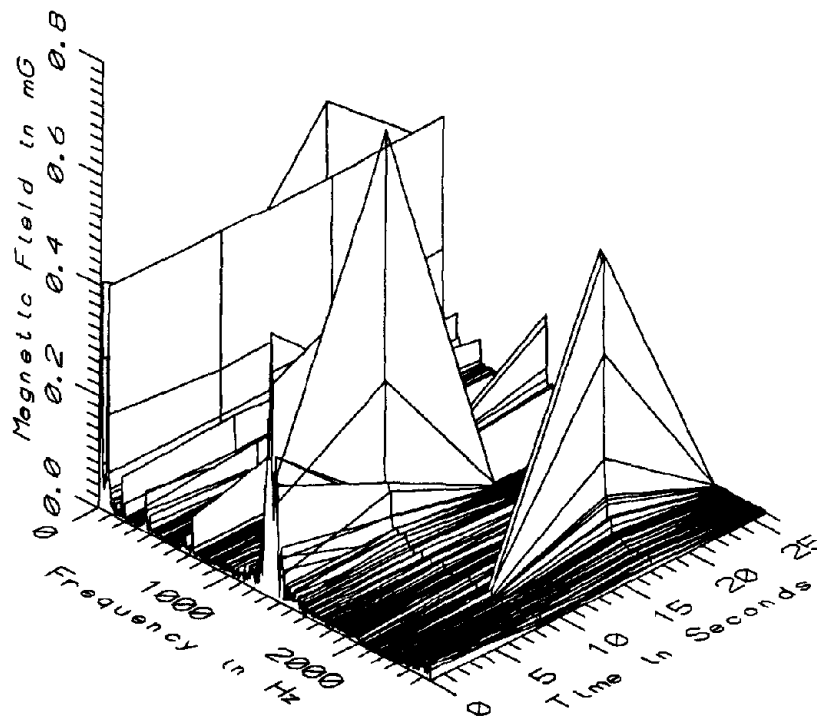

MET035 - 160cm ABOVE FLOOR OF MEZZANINE AT GALLERY PLACE

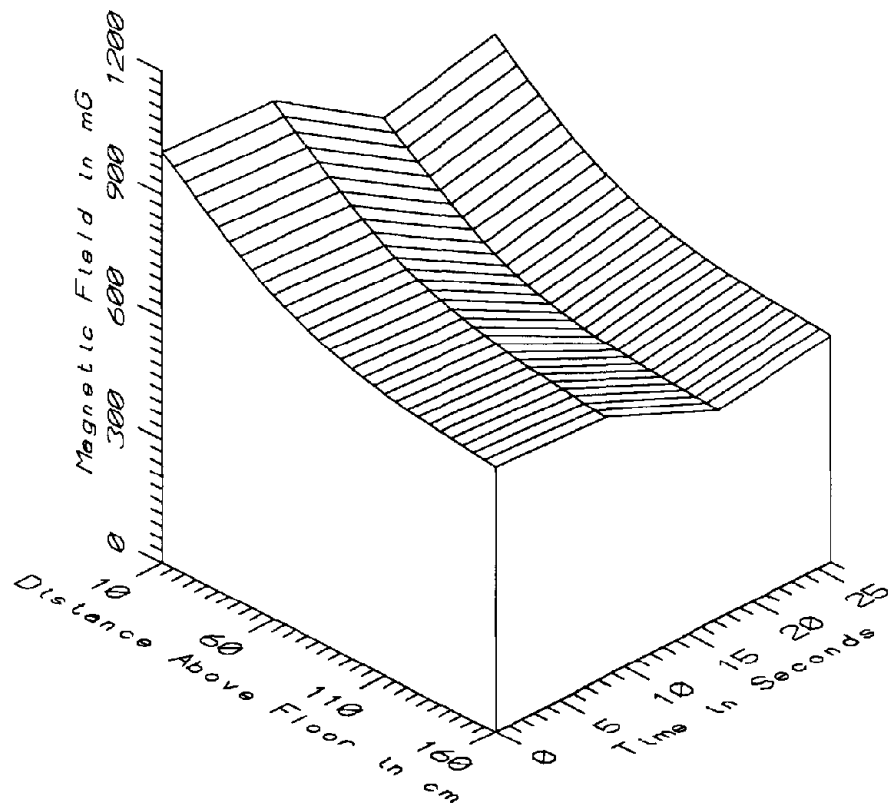

MET035 - ON MEZZANINE AT GALLERY PLACE - STATIC

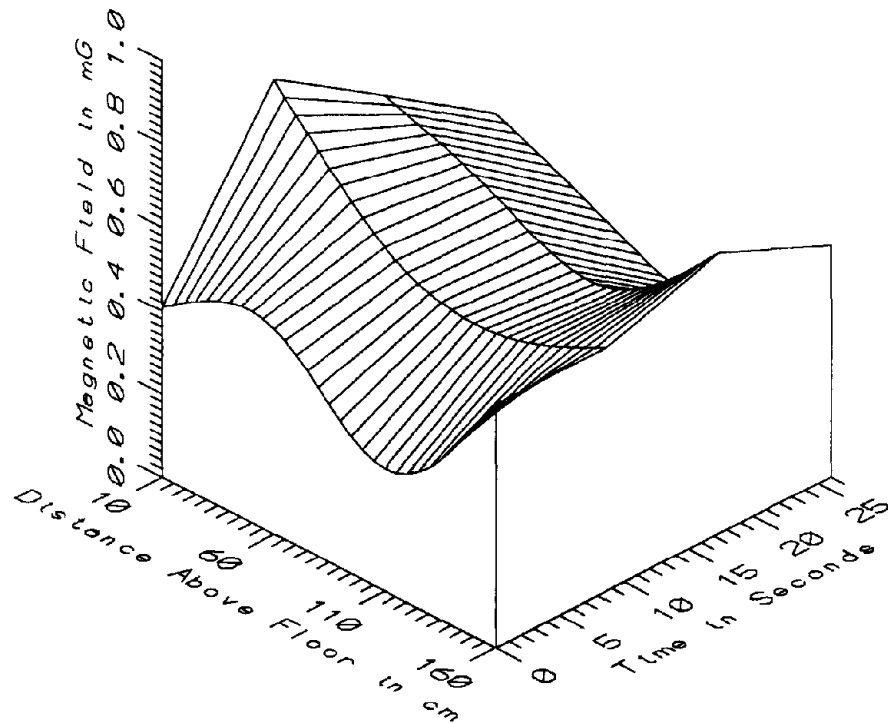

MET035 - ON MEZZANINE AT GALLERY PLACE - LOW FREQ, 5-45Hz

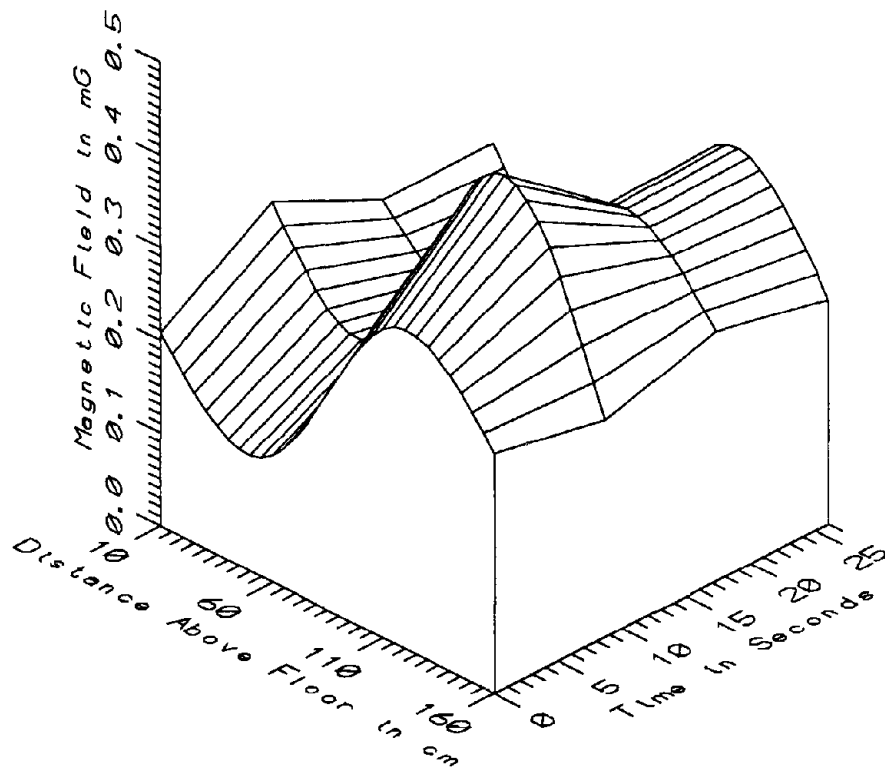

MET035 - ON MEZZANINE AT GALLERY PLACE - POWER FREQ, 50-60Hz

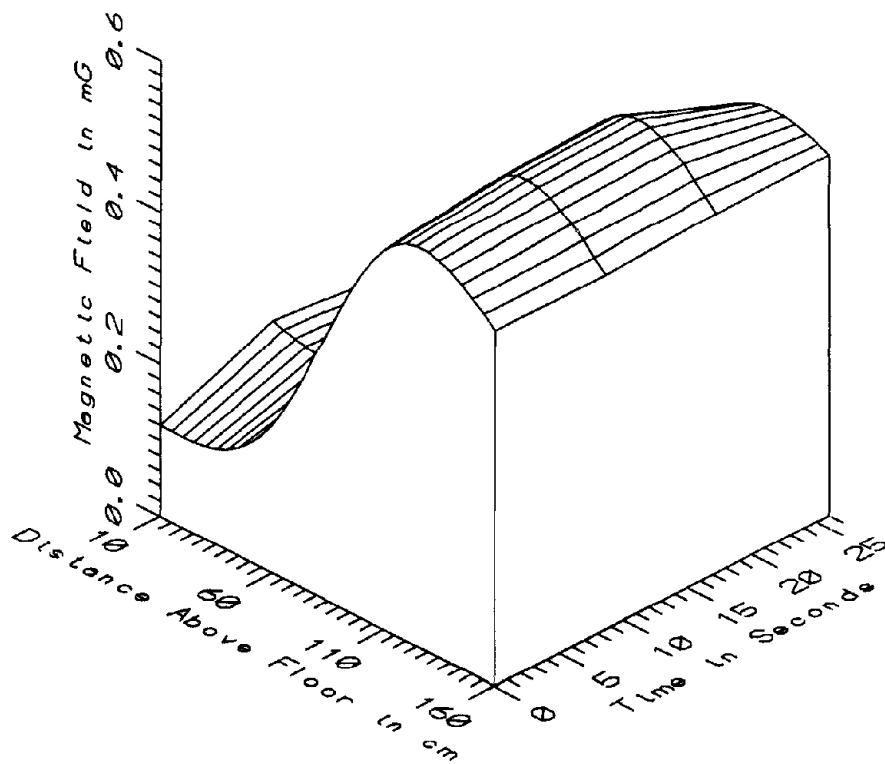

MET035 - ON MEZZANINE AT GALLERY PLACE - POWER HARM, 65-300Hz

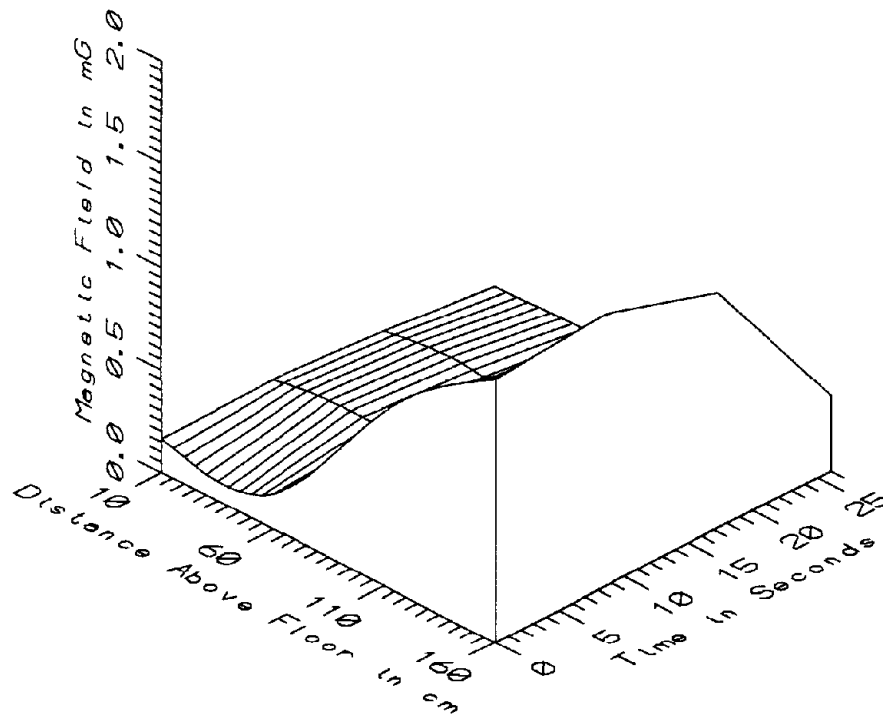

MET035 - ON MEZZANINE AT GALLERY PLACE - HIGH FREQ, 305-2560Hz

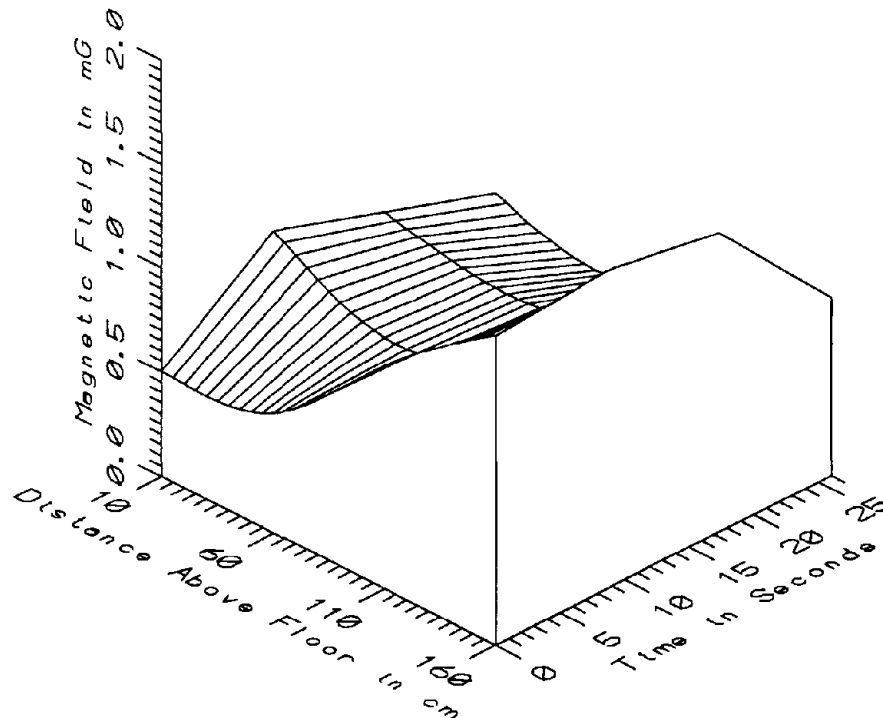

MET035 - ON MEZZANINE AT GALLERY PLACE - ALL FREQ, 5-2560Hz

MET035 - ON MEZZANINE AT GALLERY PLACE		TOTAL OF 4 SAMPLES				
FREQUENCY BAND	HEIGHT ABOVE FLOOR (cm)	MINIMUM MAGNETIC FIELD (mG)	MAXIMUM MAGNETIC FIELD (mG)	AVERAGE MAGNETIC FIELD (mG)	STANDARD DEVIATION (mG)	COEFFICIENT OF VARIATION (%)
STATIC	10	812.51	1003.71	920.69	92.12	10.01
	60	615.16	789.56	712.99	83.47	11.71
	110	535.44	685.80	619.15	71.48	11.54
	160	508.85	643.94	583.72	63.76	10.92
5-45HZ LOW FREQ	10	0.41	0.82	0.58	0.19	31.86
	60	0.34	0.55	0.48	0.10	19.97
	110	0.28	0.48	0.38	0.11	28.04
	160	0.56	0.68	0.60	0.05	8.65
50-60HZ PWR FREQ	10	0.21	0.29	0.24	0.03	14.52
	60	0.14	0.20	0.16	0.03	20.06
	110	0.33	0.44	0.37	0.05	13.73
	160	0.23	0.27	0.25	0.02	6.36
65-300HZ PWR HARM	10	0.11	0.18	0.15	0.03	23.27
	60	0.18	0.24	0.21	0.03	13.18
	110	0.46	0.52	0.50	0.03	5.95
	160	0.46	0.47	0.47	0.01	1.21
305-2560HZ HIGH FREQ	10	0.09	0.18	0.14	0.04	28.79
	60	0.10	0.20	0.15	0.04	29.06
	110	0.12	0.84	0.35	0.34	97.10
	160	0.37	1.31	1.02	0.44	43.16
5-2560HZ ALL FREQ	10	0.50	0.91	0.67	0.19	27.89
	60	0.42	0.66	0.57	0.11	18.77
	110	0.65	1.07	0.85	0.18	20.84
	160	0.85	1.53	1.33	0.32	23.90



APPENDIX AG

DATASET MET037  
ON MEZZANINE AT GALLERY PLACE STATION

Measurement Setup Code:        Staff:    35    Reference: -  
   Drawing:  A-5

Vehicle Status:                NA

Measurement Date:              May 19, 1992

Measurement Time:              Start:    16:11:13  
   End:      16:12:45

Number of Samples:             18

Programmed Sample Interval:    5 sec

Actual Sample Interval:        5.4 sec

Frequency Spectrum Parameters

<u>Probe Type:</u>	<u>Wideband</u>	<u>Static</u>
Maximum Frequency (Hz)	2560	100
Minimum Frequency (Hz)	5	0
Spectral Bandwidth (Hz)	5	1

Missing Data: No reference probe

Saturated Data: None

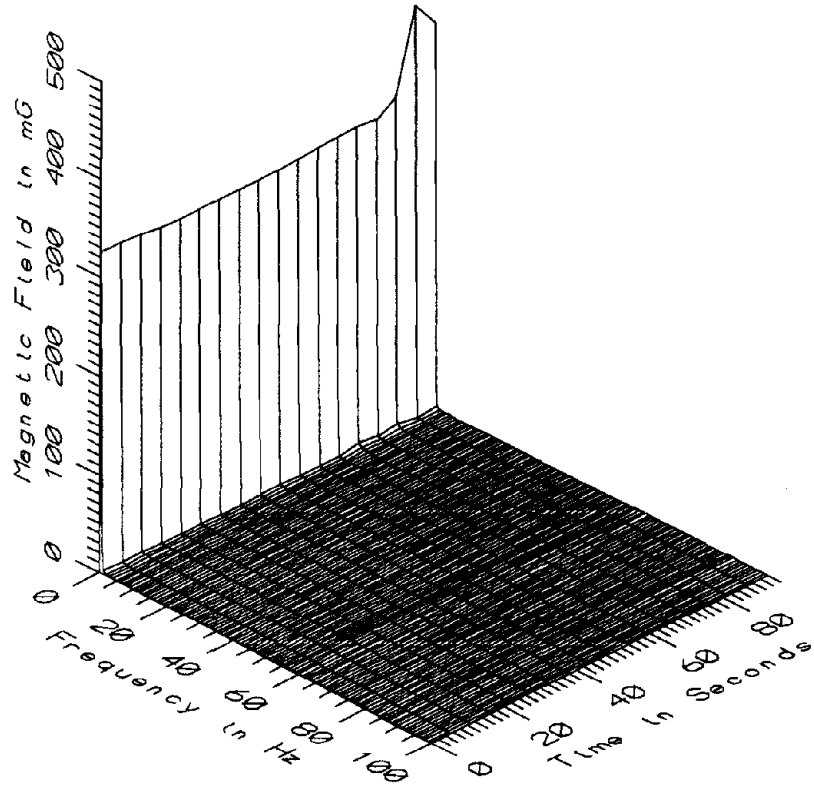

MET037 - 10cm ABOVE FLOOR OF MEZZANINE AT GALLERY PLACE

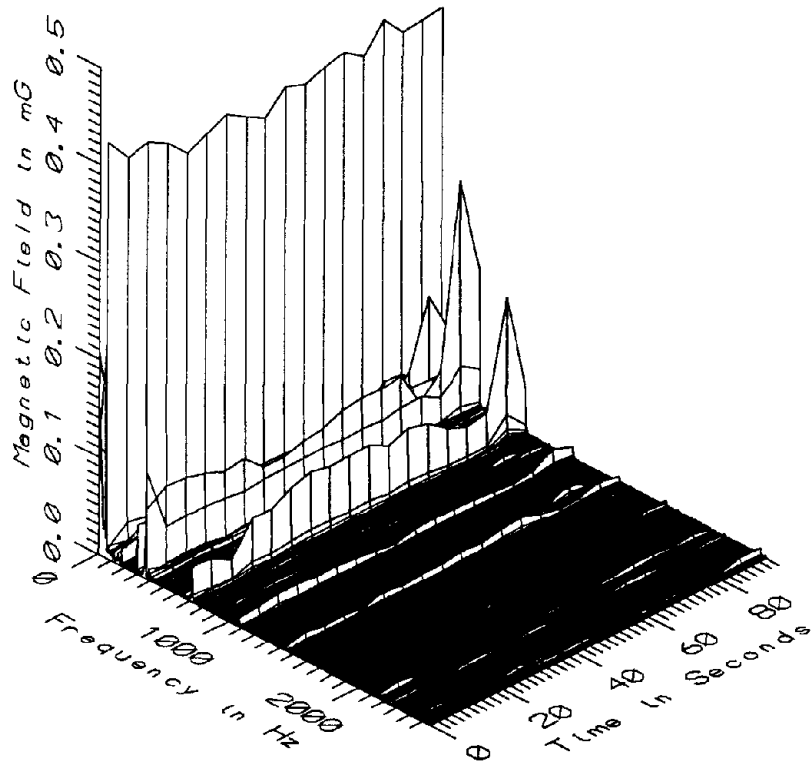

MET037 - 10cm ABOVE FLOOR OF MEZZANINE AT GALLERY PLACE



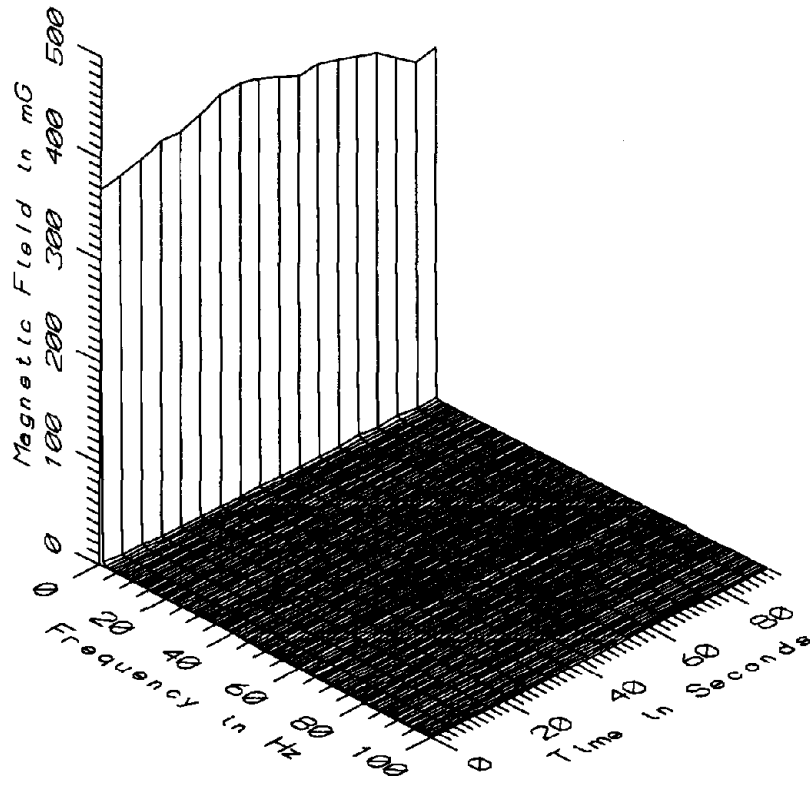

MET037 - 60cm ABOVE FLOOR OF MEZZANINE AT GALLERY PLACE

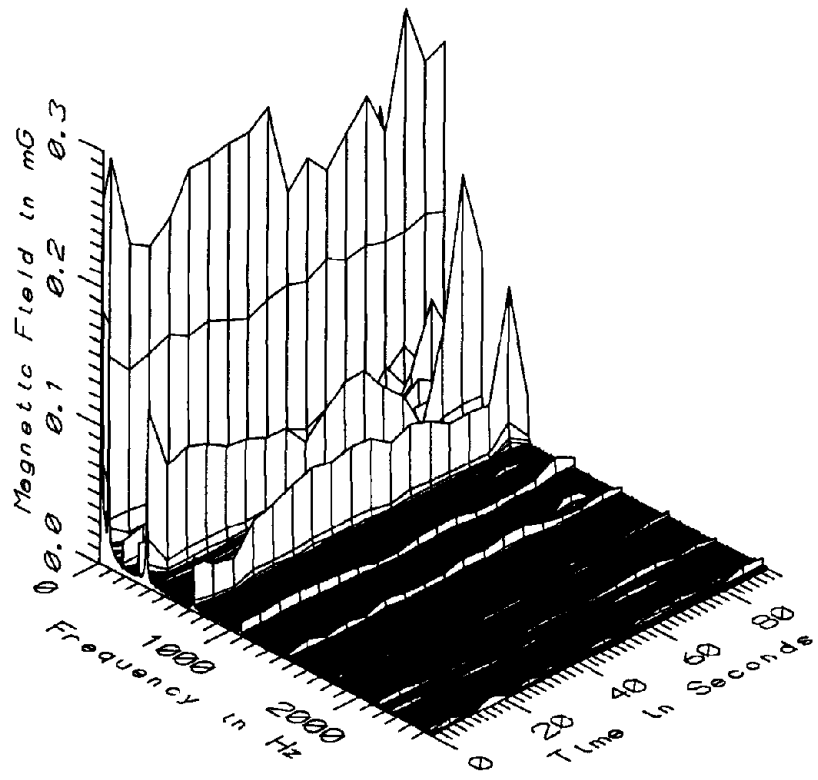

MET037 - 60cm ABOVE FLOOR OF MEZZANINE AT GALLERY PLACE

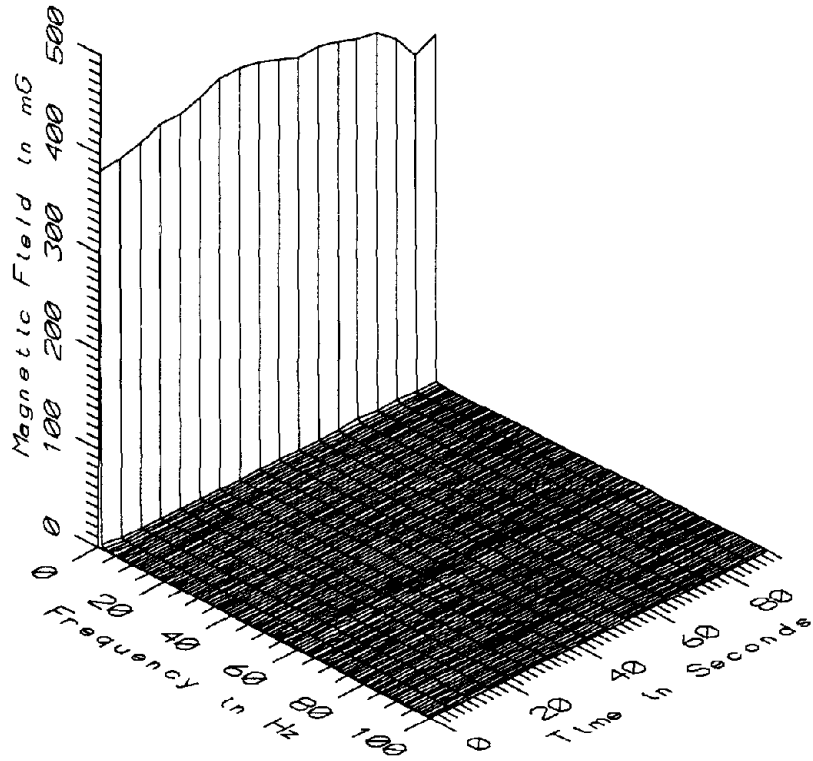

MET037 - 110cm ABOVE FLOOR OF MEZZANINE AT GALLERY PLACE

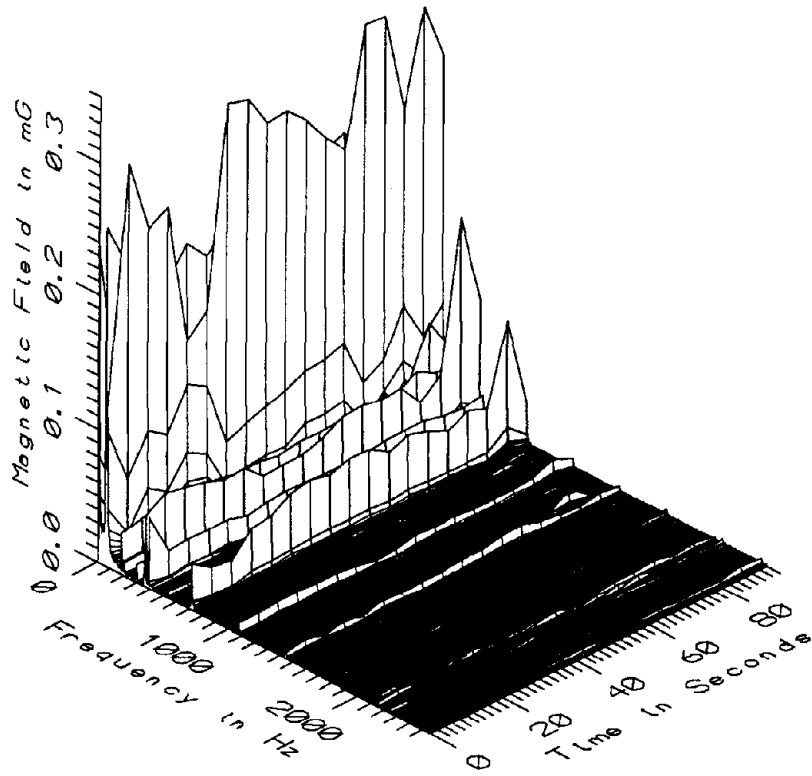

MET037 - 110cm ABOVE FLOOR OF MEZZANINE AT GALLERY PLACE

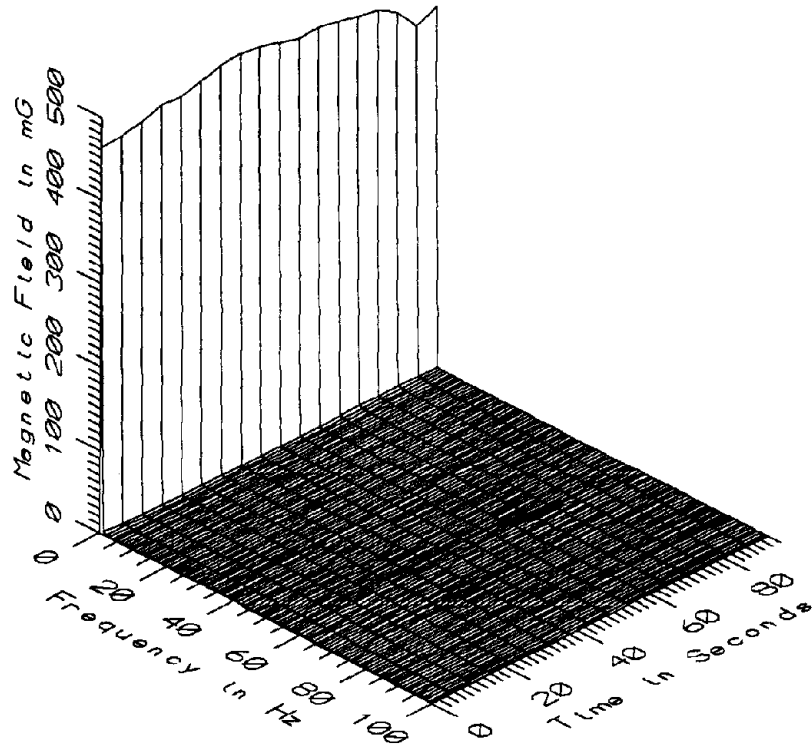

MET037 - 160cm ABOVE FLOOR OF MEZZANINE AT GALLERY PLACE

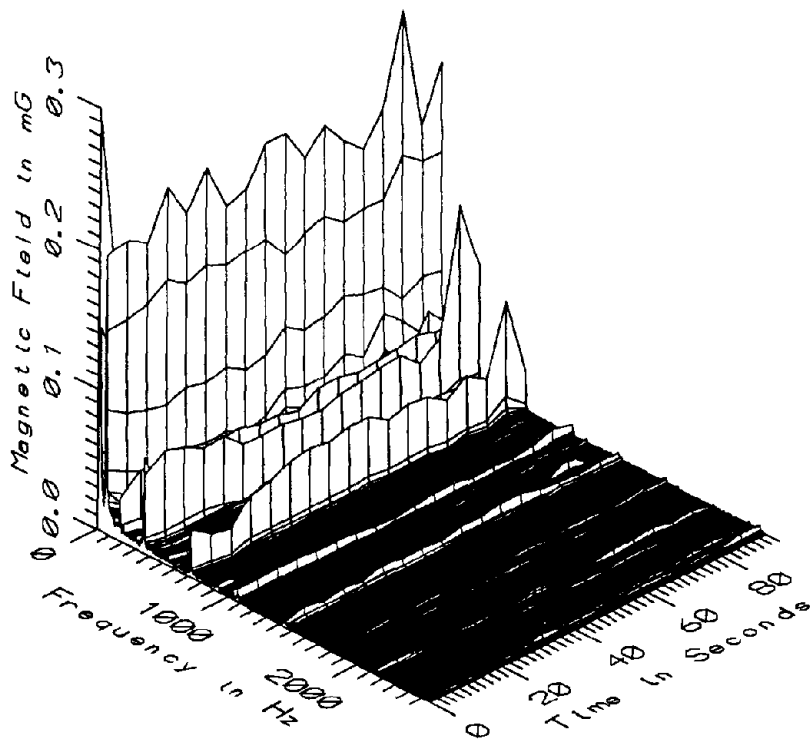

MET037 - 160cm ABOVE FLOOR OF MEZZANINE AT GALLERY PLACE

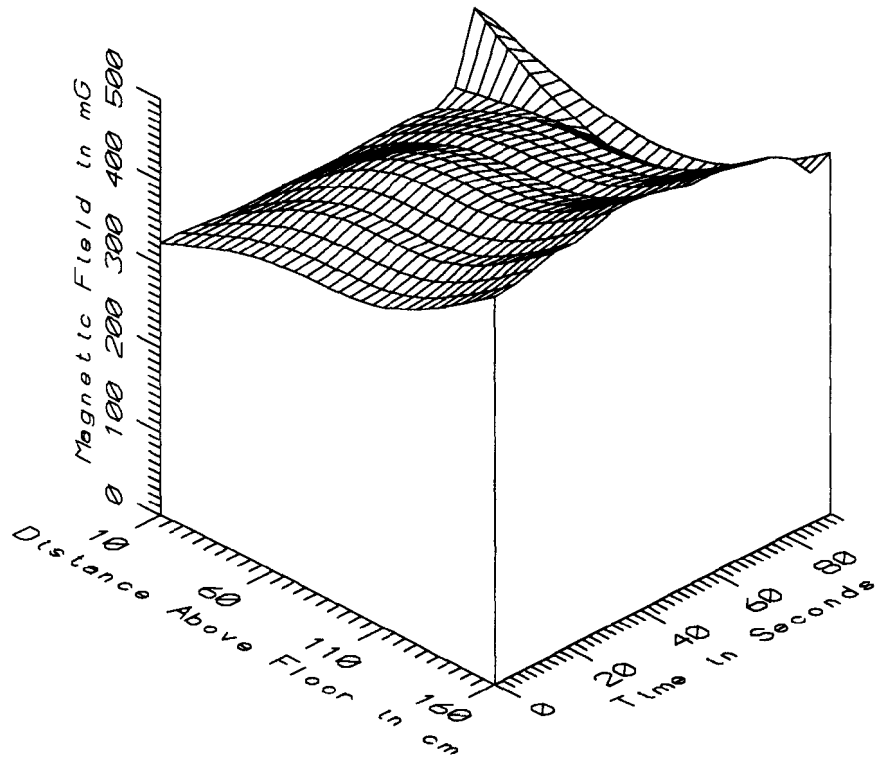

MET037 - ON MEZZANINE AT GALLERY PLACE - STATIC

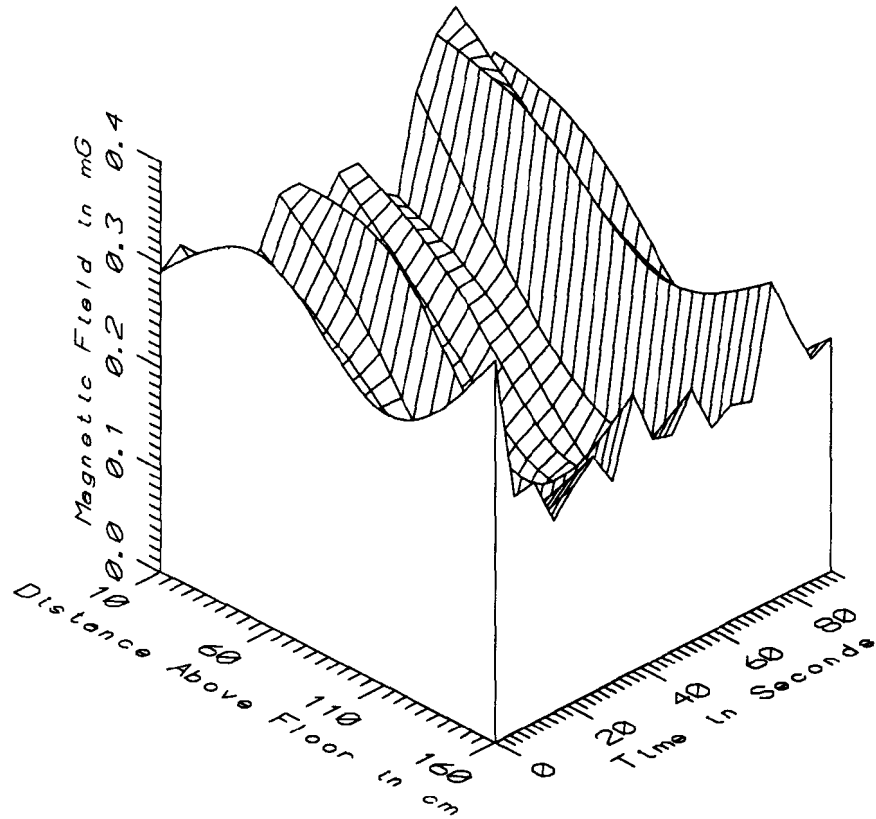

MET037 - ON MEZZANINE AT GALLERY PLACE - LOW FREQ, 5-45Hz

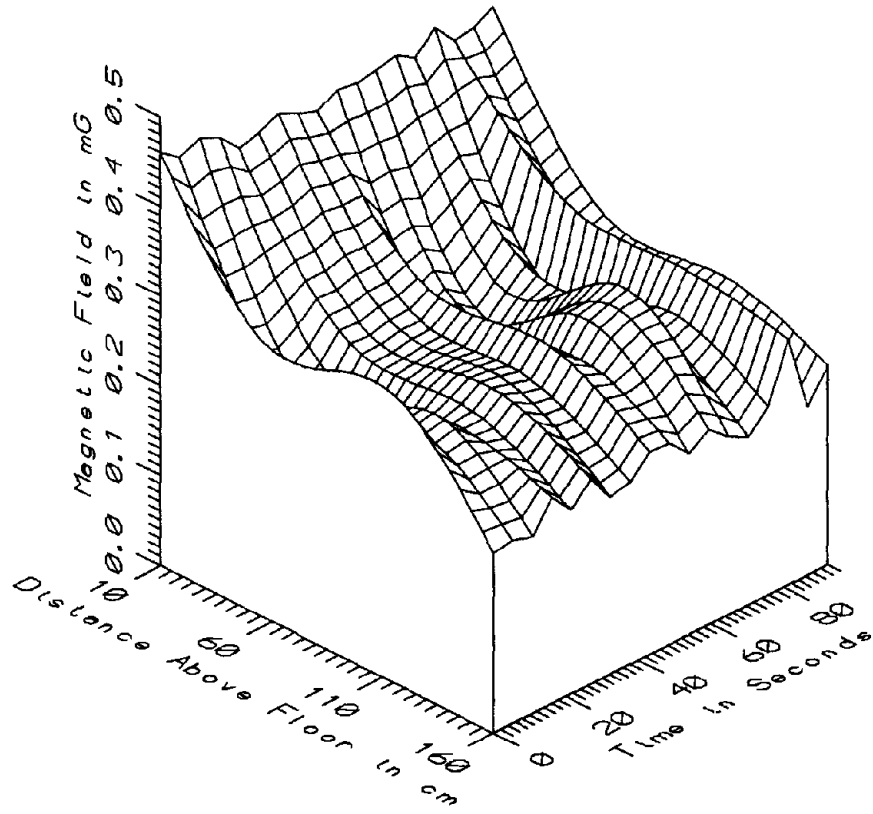

MET037 - ON MEZZANINE AT GALLERY PLACE - POWER FREQ, 50-60Hz

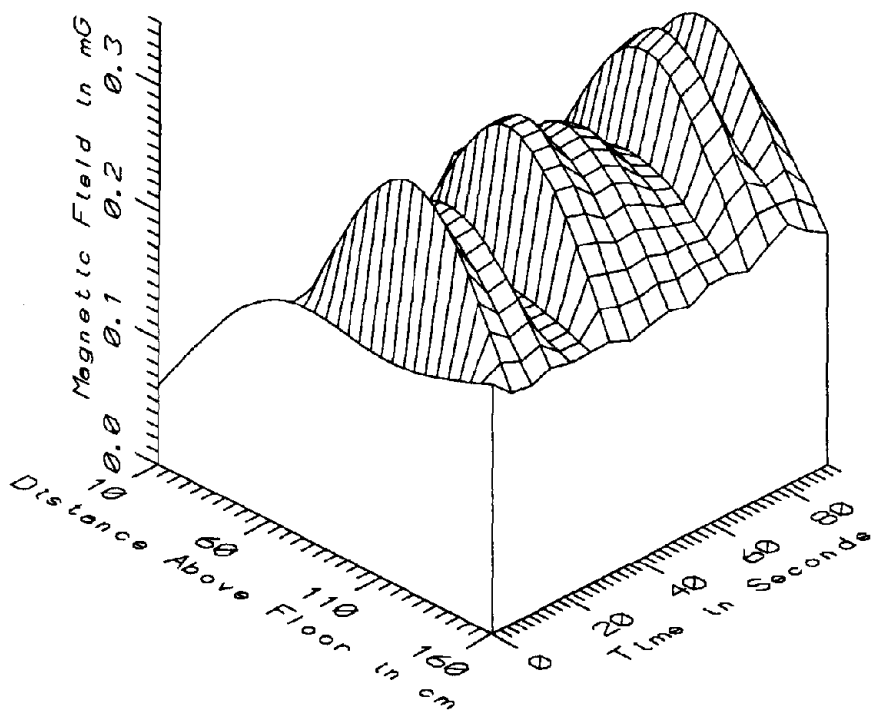

MET037 - ON MEZZANINE AT GALLERY PLACE - POWER HARM, 65-300Hz

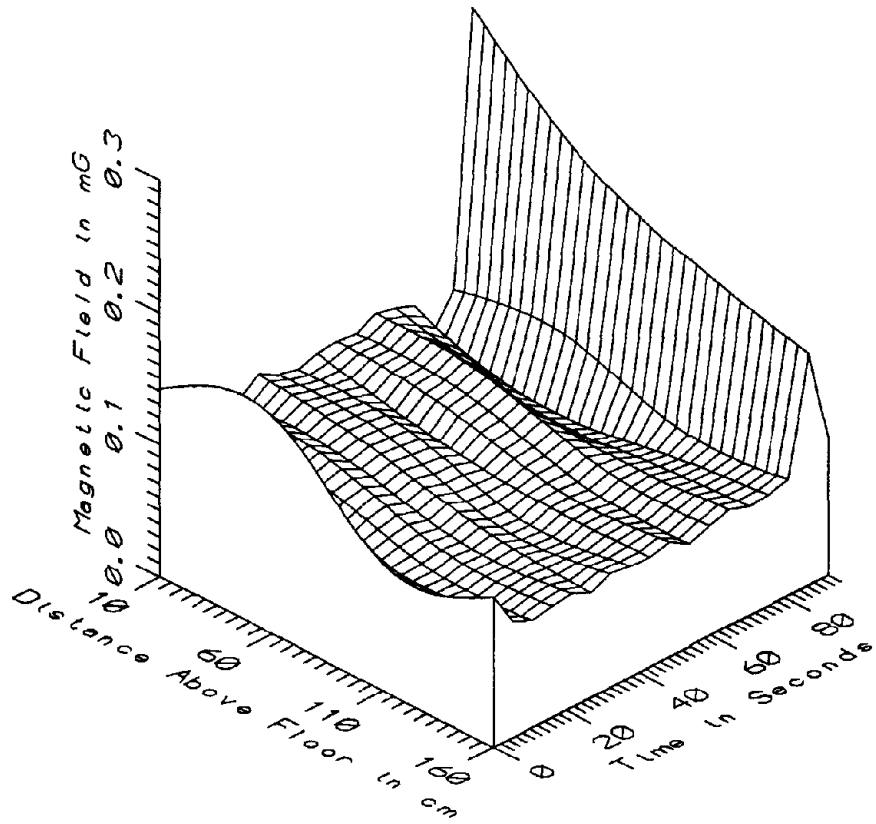

MET037 - ON MEZZANINE AT GALLERY PLACE - HIGH FREQ, 305-2560Hz

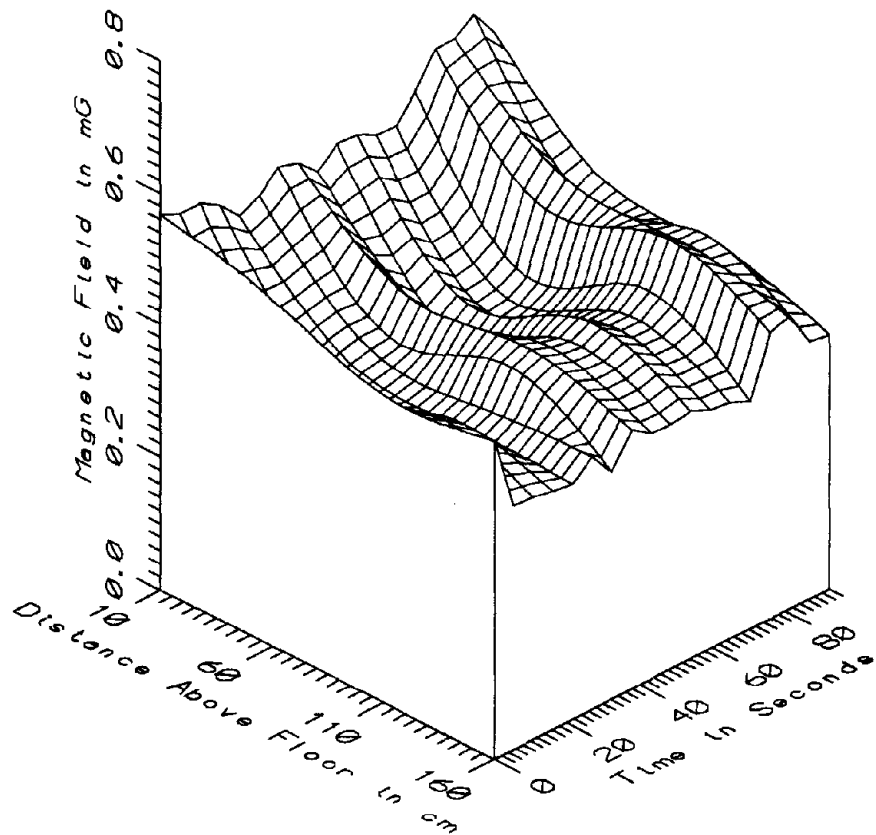

MET037 - ON MEZZANINE AT GALLERY PLACE - ALL FREQ, 5-2560Hz

MET037 - ON MEZZANINE AT GALLERY PLACE		TOTAL OF 4 SAMPLES				
FREQUENCY BAND	HEIGHT ABOVE FLOOR (cm)	MINIMUM MAGNETIC FIELD (mG)	MAXIMUM MAGNETIC FIELD (mG)	AVERAGE MAGNETIC FIELD (mG)	STANDARD DEVIATION (mG)	COEFFICIENT OF VARIATION (%)
STATIC	10	318.95	417.47	331.28	27.14	8.19
	60	340.37	406.92	380.05	19.19	5.05
	110	341.50	418.42	391.86	20.94	5.34
	160	420.70	494.63	470.40	19.64	4.17
5-45Hz LOW FREQ	10	0.25	0.41	0.30	0.04	14.35
	60	0.17	0.35	0.22	0.06	27.90
	110	0.06	0.27	0.13	0.07	51.56
50-60Hz PWR FREQ	160	0.19	0.37	0.24	0.05	19.35
	10	0.42	0.46	0.43	0.01	2.82
	60	0.21	0.30	0.25	0.03	11.00
65-300Hz PWR HARM	110	0.25	0.32	0.28	0.02	7.31
	160	0.19	0.27	0.21	0.02	9.63
	10	0.06	0.13	0.08	0.02	31.44
305-2560Hz HIGH FREQ	60	0.15	0.18	0.16	0.01	6.86
	110	0.17	0.33	0.27	0.04	15.75
	160	0.18	0.21	0.19	0.01	3.79
5-2560Hz ALL FREQ	10	0.08	0.31	0.12	0.05	39.97
	60	0.07	0.24	0.11	0.04	34.11
	110	0.07	0.20	0.09	0.03	32.07
	160	0.08	0.18	0.09	0.02	25.26
	10	0.51	0.63	0.55	0.04	6.35
	60	0.34	0.52	0.39	0.05	13.91
	110	0.36	0.50	0.42	0.04	8.31
	160	0.34	0.48	0.38	0.04	9.39

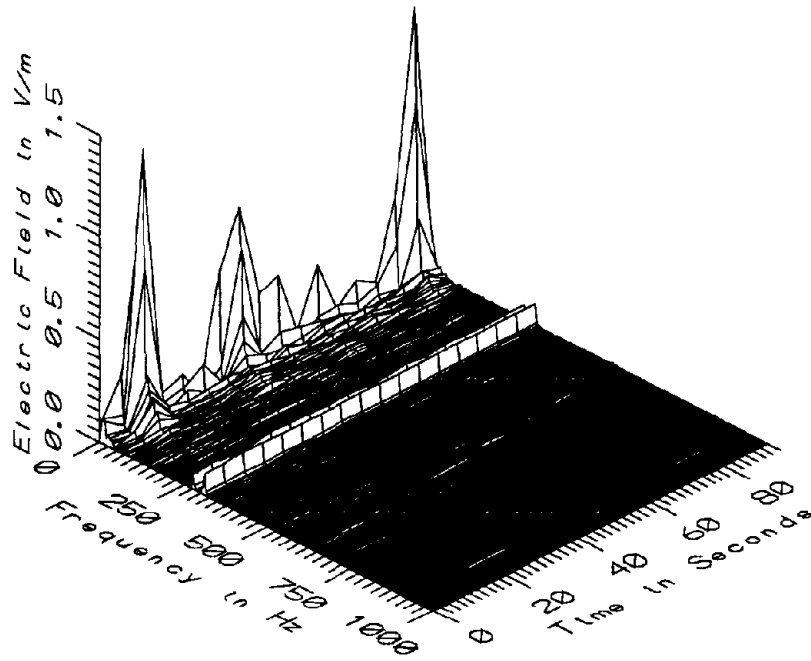

MET037 - ELECTRIC FIELD ON MEZZANINE AT GALLERY PLACE



APPENDIX AH

DATASET MET038

AT TRACTION POWER SUPPLY STATION SOUTH OF SHADY GROVE

Measurement Setup Code:        Staff:     36    Reference: -  
   Drawing:  A-6

Vehicle Status:                 NA

Measurement Date:               May 20, 1992

Measurement Time:               Start:     08:38:58  
   End:        08:42:06

Number of Samples:              38

Programmed Sample Interval:    5 sec

Actual Sample Interval:         5.1 sec

Frequency Spectrum Parameters

<u>Probe Type:</u>	<u>Wideband</u>	<u>Static</u>
Maximum Frequency (Hz)	2560	100
Minimum Frequency (Hz)	5	0
Spectral Bandwidth (Hz)	5	1

Missing Data: No reference probe

Saturated Data: None

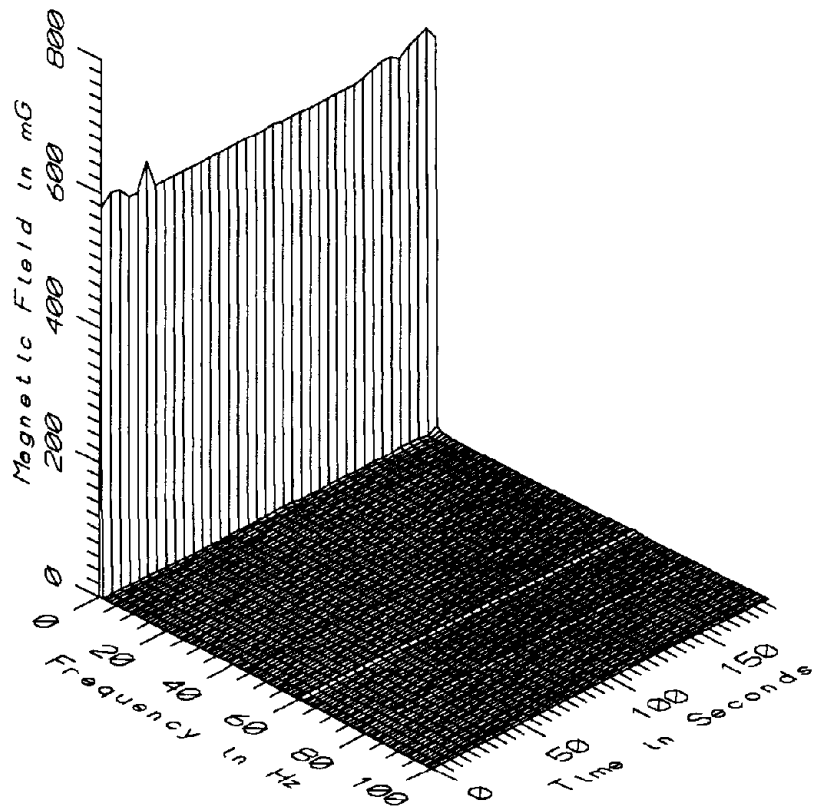

MET038 - 10cm FROM NORTH WALL OF TRACTION POWER SUPPLY STATION

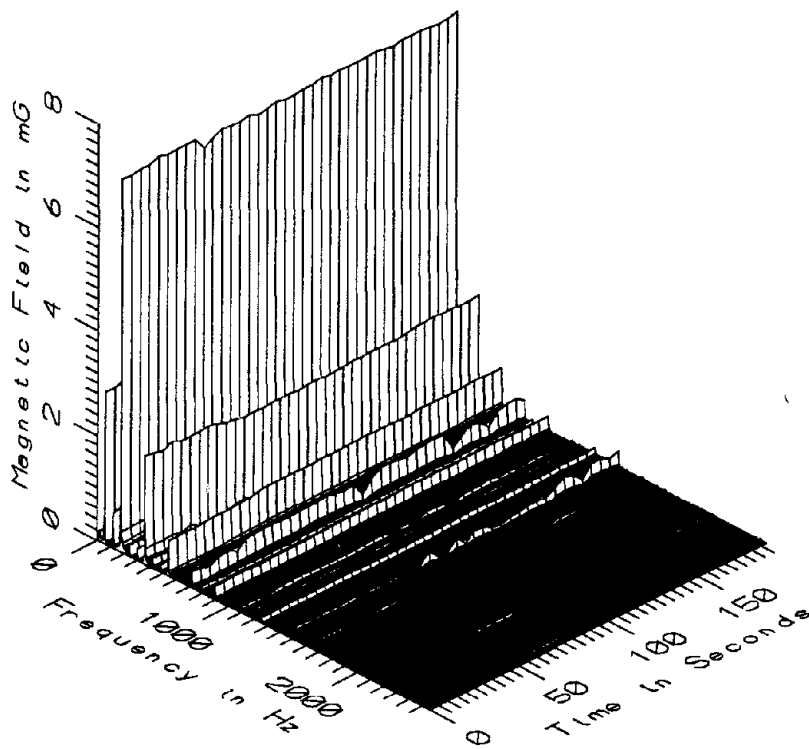

MET038 - 10cm FROM NORTH WALL OF TRACTION POWER SUPPLY STATION

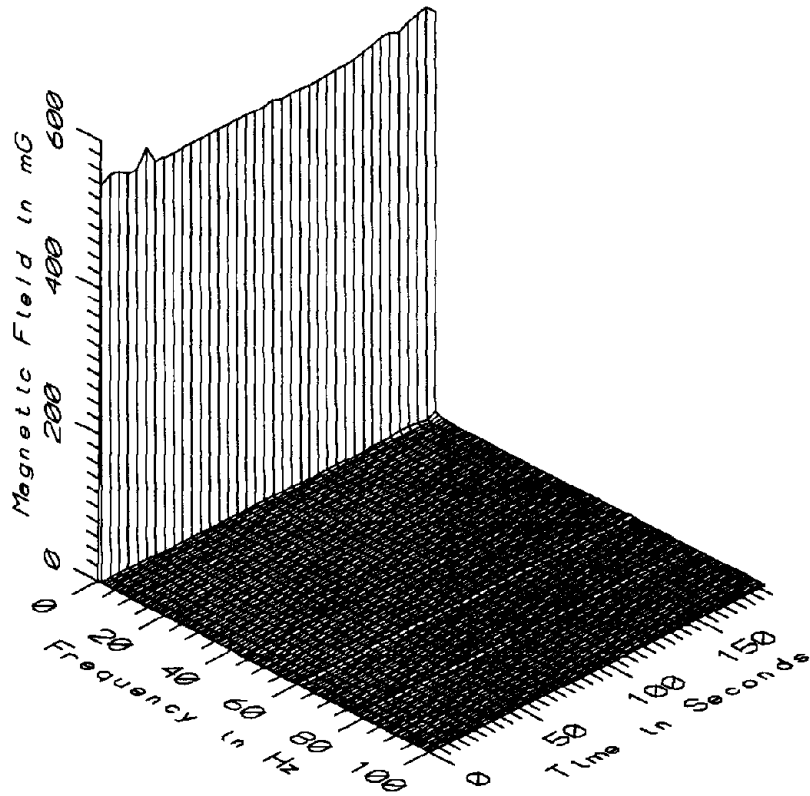

MET038 - 60cm FROM NORTH WALL OF TRACTION POWER SUPPLY STATION

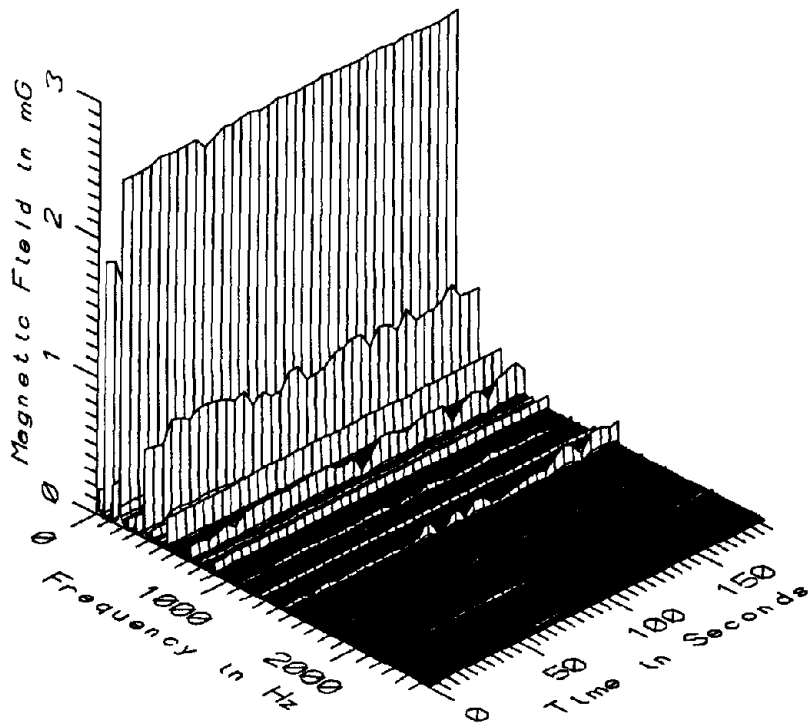

MET038 - 60cm FROM NORTH WALL OF TRACTION POWER SUPPLY STATION

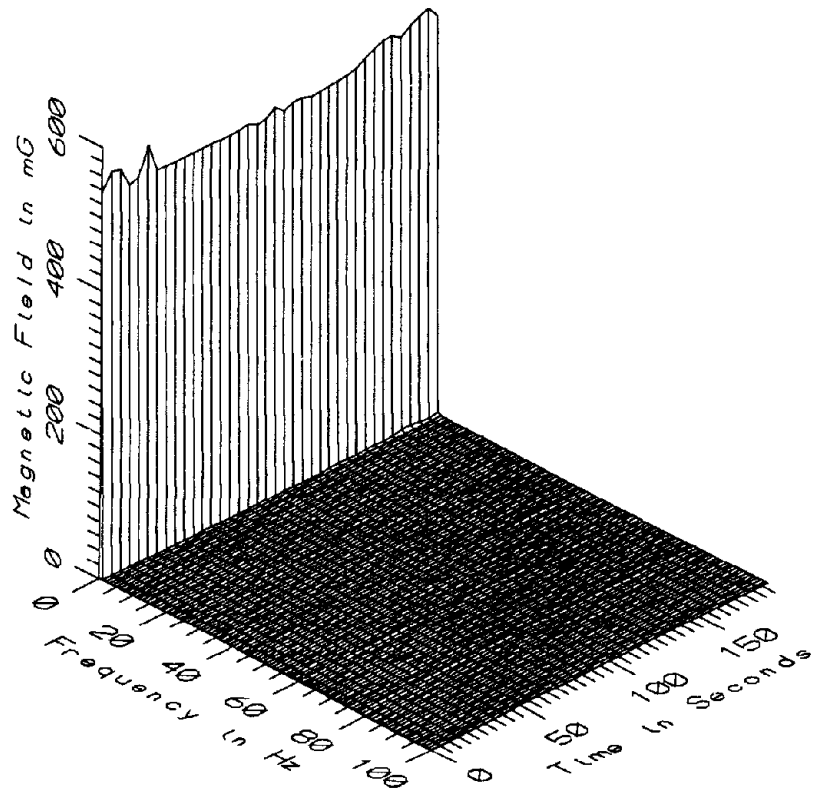

MET038 - 110cm FROM NORTH WALL OF TRACTION POWER SUPPLY STATION

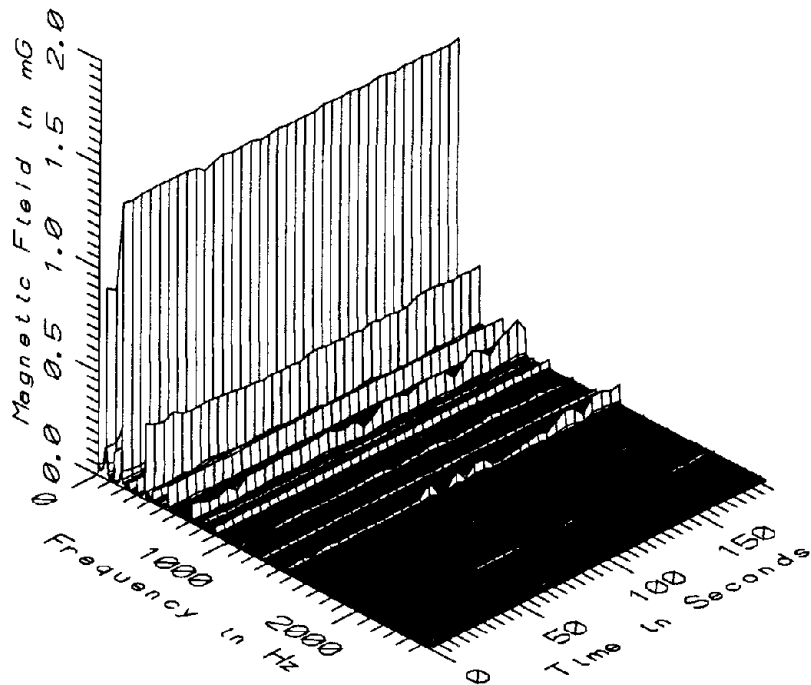

MET038 - 110cm FROM NORTH WALL OF TRACTION POWER SUPPLY STATION

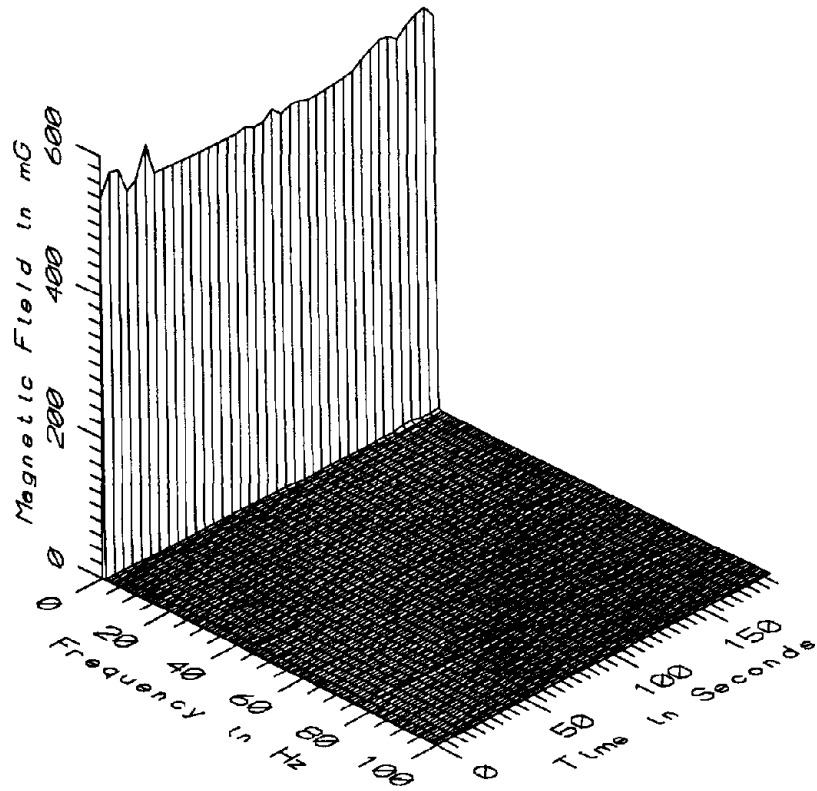

MET038 - 160cm FROM NORTH WALL OF TRACTION POWER SUPPLY STATION

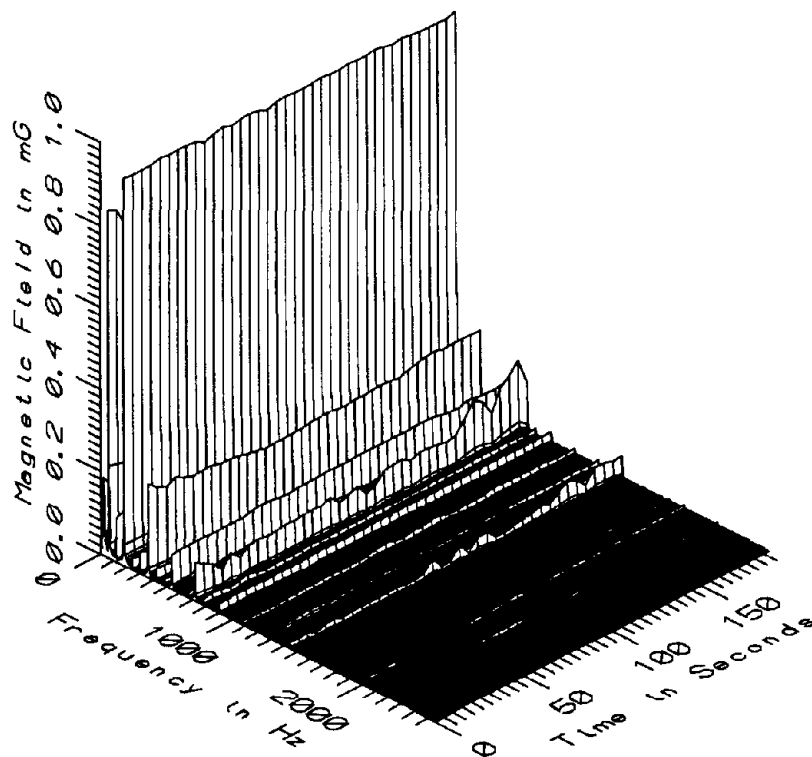

MET038 - 160cm FROM NORTH WALL OF TRACTION POWER SUPPLY STATION

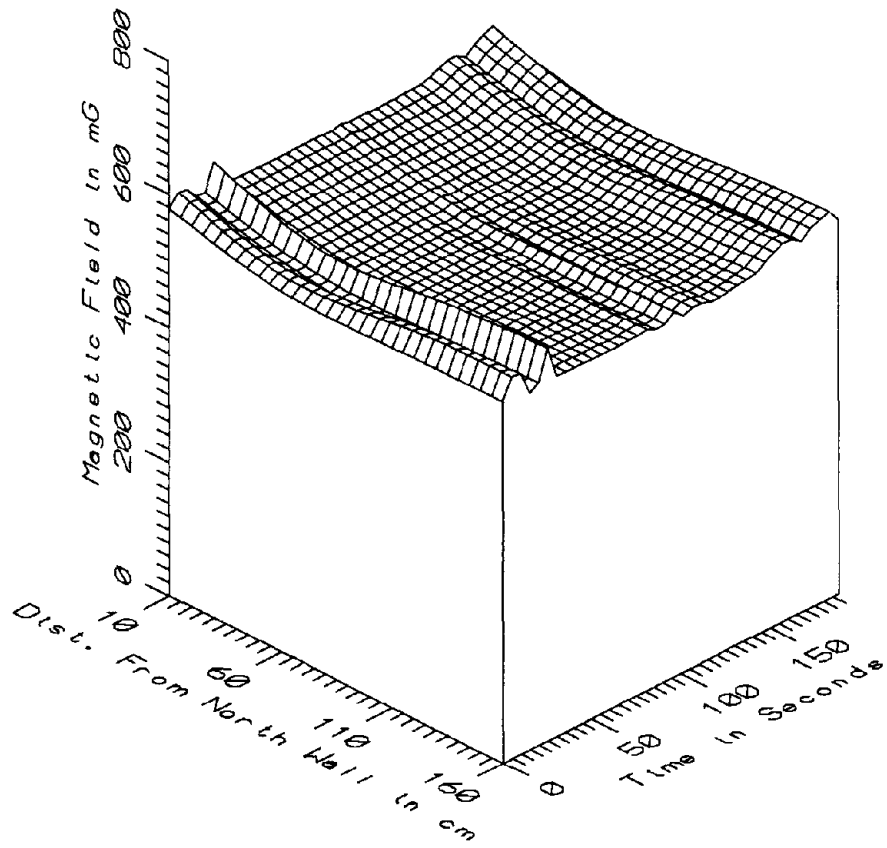

MET038 - TRACTION POWER SUPPLY STATION - STATIC

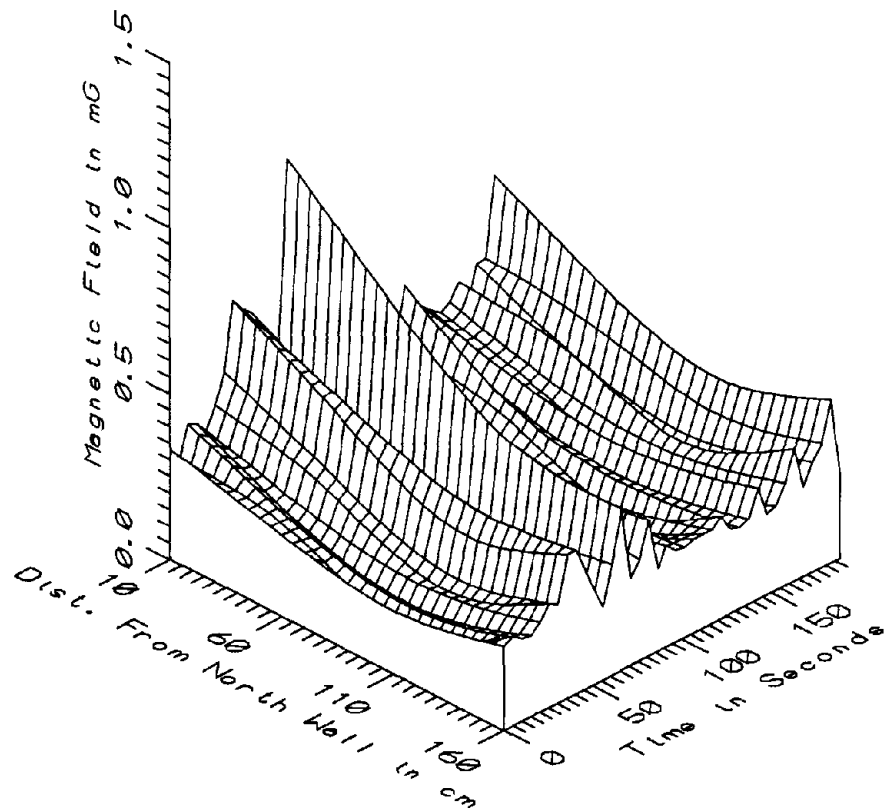

MET038 - TRACTION POWER SUPPLY STATION - LOW FREQ, 5-45Hz

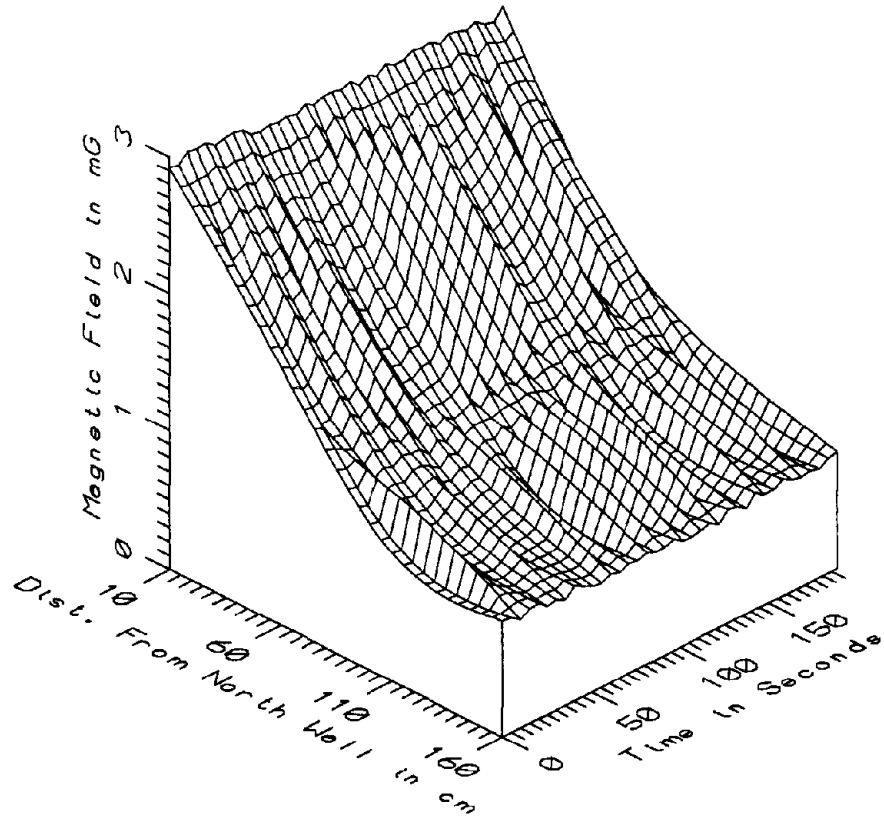

MET038 - TRACTION POWER SUPPLY STATION - POWER FREQ, 50-60Hz

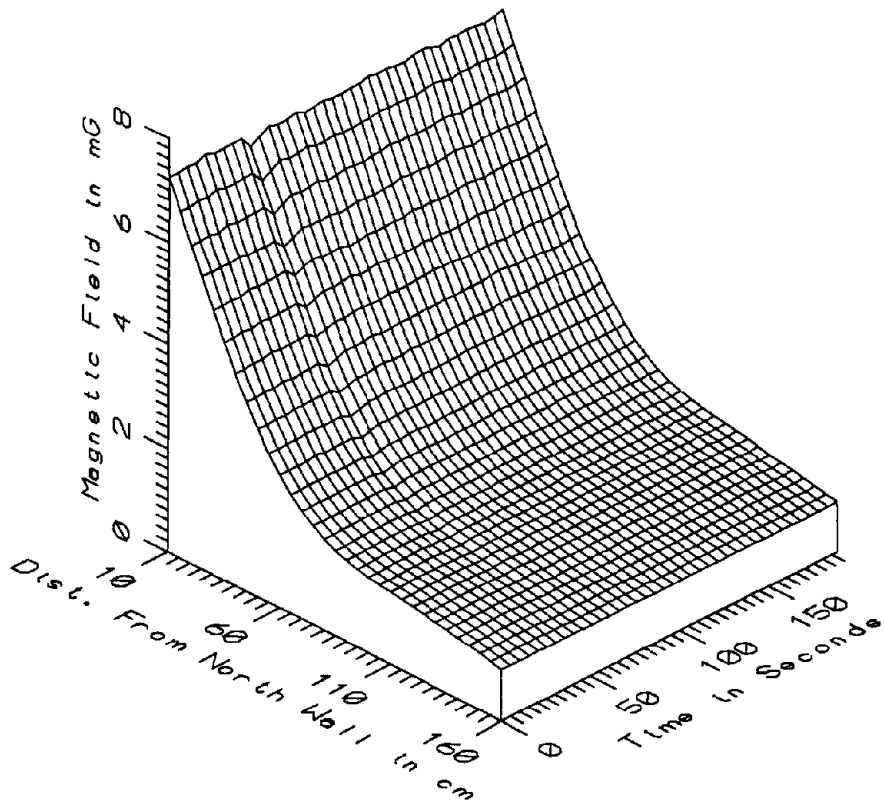

MET038 - TRACTION POWER SUPPLY STATION - POWER HARM, 65-300Hz

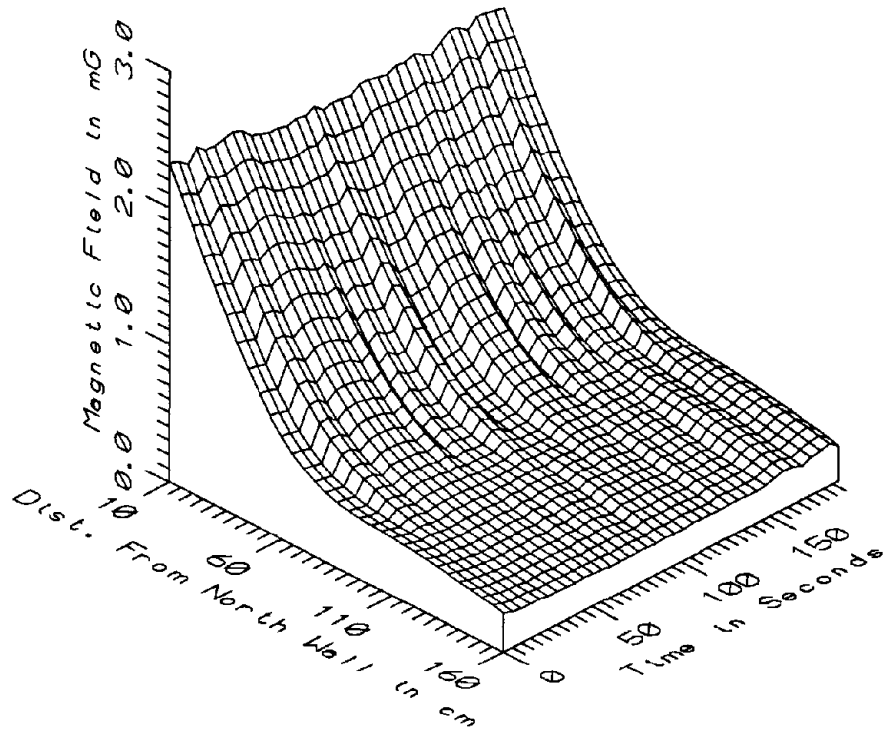

MET038 - TRACTION POWER SUPPLY STATION - HIGH FREQ, 305-2560Hz

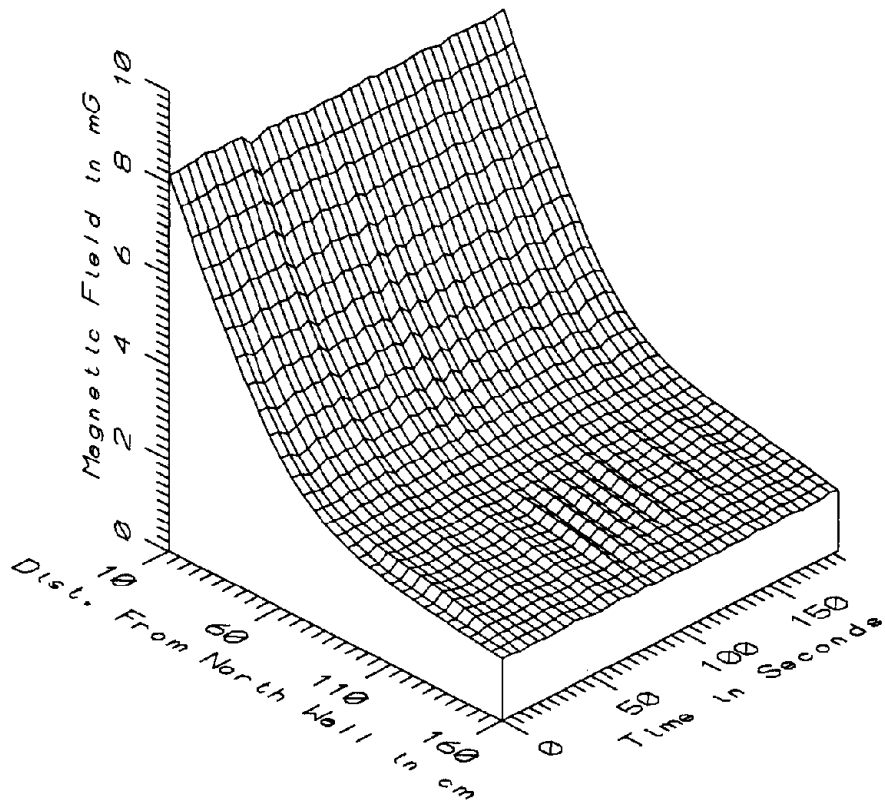

MET038 - TRACTION POWER SUPPLY STATION - ALL FREQ, 5-2560Hz



MET038 - T.P.S.S. SOUTH OF SHADY GROVE, FROM NORTH WALL TOTAL OF 38 SAMPLES						
FREQUENCY BAND	DIST FROM WALL (cm)	MINIMUM MAGNETIC FIELD (mG)	MAXIMUM MAGNETIC FIELD (mG)	AVERAGE MAGNETIC FIELD (mG)	STANDARD DEVIATION (mG)	COEFFICIENT OF VARIATION (%)
STATIC	10	572.41	614.11	579.22	10.41	1.80
	60	534.24	562.01	540.66	7.91	1.46
	110	526.56	572.97	538.86	13.13	2.44
	160	529.74	583.83	544.10	15.50	2.85
5-45Hz	10	0.29	1.03	0.44	0.14	33.02
LOW FREQ	60	0.18	0.73	0.30	0.11	36.43
	110	0.12	0.51	0.23	0.08	36.39
	160	0.22	0.49	0.30	0.07	22.65
50-60Hz	10	2.79	2.97	2.87	0.04	1.52
PWR FREQ	60	1.52	1.86	1.71	0.11	6.48
	110	0.89	1.20	1.02	0.09	8.58
	160	0.75	0.85	0.80	0.03	3.32
65-300Hz	10	7.04	7.34	7.22	0.05	0.73
PWR HARM	60	2.50	2.61	2.58	0.02	0.69
	110	1.38	1.42	1.40	0.01	0.78
	160	0.96	0.98	0.97	0.01	0.60
305-2560Hz	10	2.15	2.34	2.23	0.05	2.38
HIGH FREQ	60	0.70	0.91	0.80	0.06	7.39
	110	0.37	0.45	0.40	0.02	5.61
	160	0.23	0.31	0.24	0.02	8.26
5-2560Hz	10	7.95	8.25	8.10	0.07	0.81
ALL FREQ	60	3.10	3.31	3.21	0.06	1.96
	110	1.71	1.90	1.79	0.05	2.80
	160	1.28	1.39	1.32	0.03	2.02

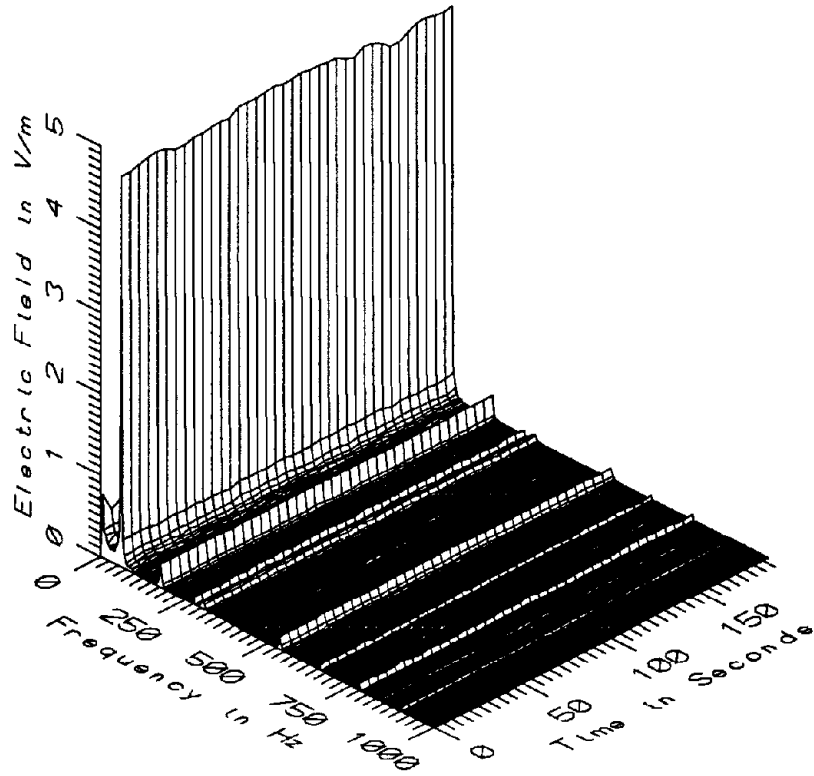

MET038 - ELECTRIC FIELD AT TRACTION POWER SUPPLY STATION

APPENDIX AI

DATASET MET039  
AT TRACTION POWER SUPPLY STATION SOUTH OF SHADY GROVE

Measurement Setup Code:        Staff:     38    Reference: -  
   Drawing:  A-6

Vehicle Status:                NA

Measurement Date:              May 20, 1992

Measurement Time:              Start:     08:44:29  
   End:        08:47:56

Number of Samples:             38

Programmed Sample Interval:    5 sec

Actual Sample Interval:        5.6 sec

**Frequency Spectrum Parameters**

<u>Probe Type:</u>	<u>Wideband</u>	<u>Static</u>
Maximum Frequency (Hz)	2560	100
Minimum Frequency (Hz)	5	0
Spectral Bandwidth (Hz)	5	1

Missing Data: No reference probe

Saturated Data: None

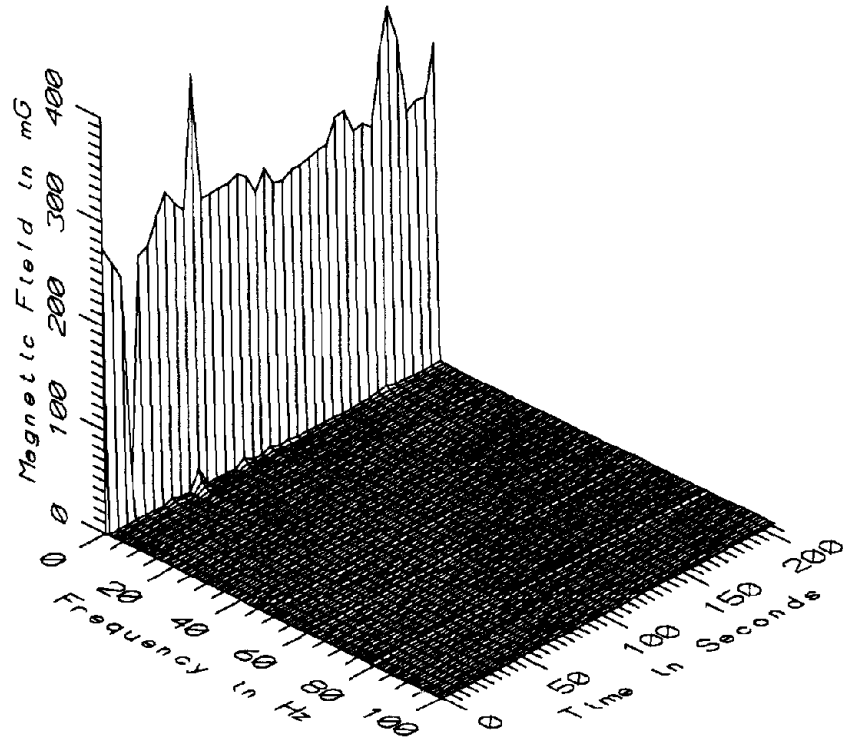

MET039 - 10cm FROM WEST WALL OF TRACTION POWER SUPPLY STATION

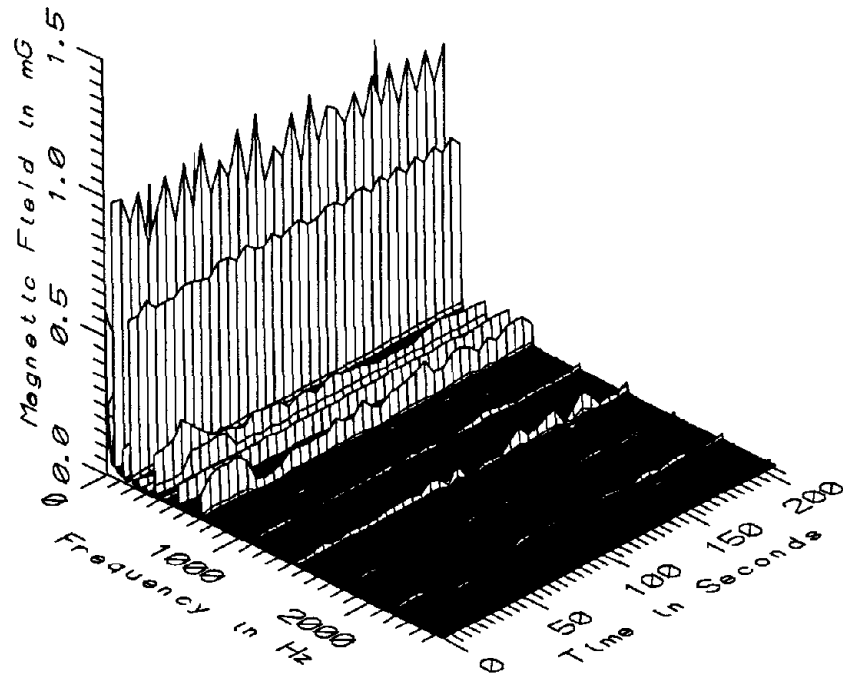

MET039 - 10cm FROM WEST WALL OF TRACTION POWER SUPPLY STATION

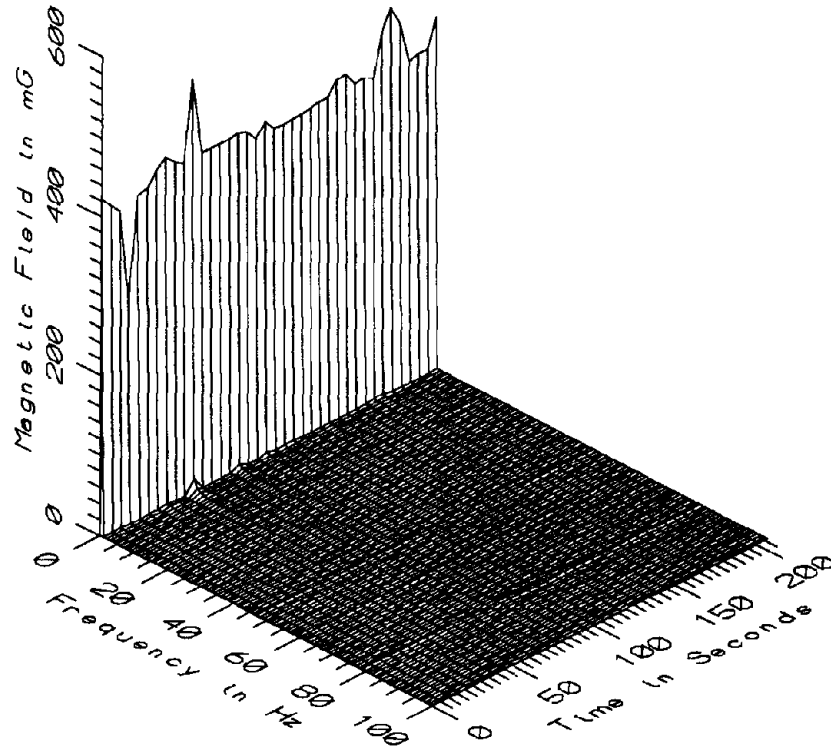

MET039 - 60cm FROM WEST WALL OF TRACTION POWER SUPPLY STATION

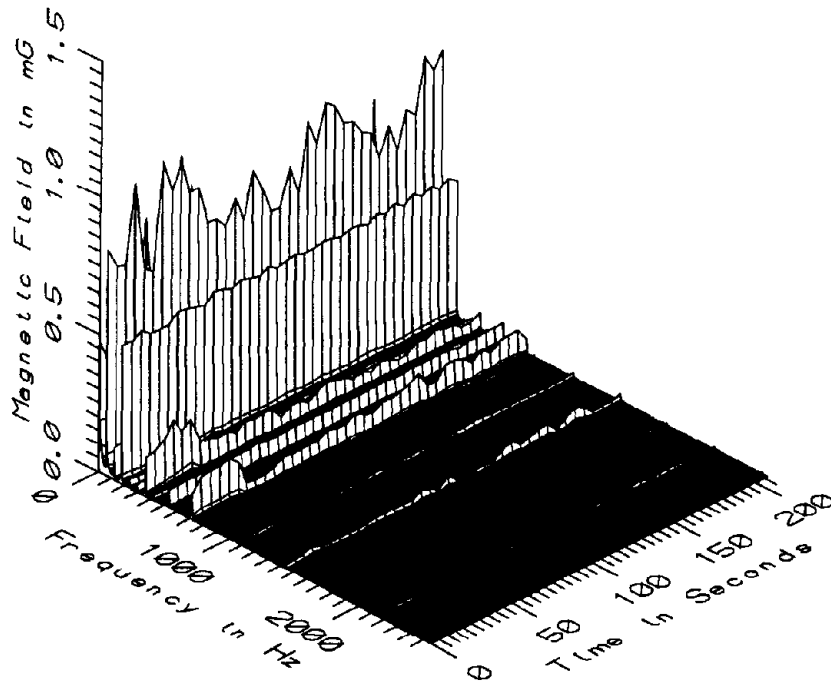

MET039 - 60cm FROM WEST WALL OF TRACTION POWER SUPPLY STATION

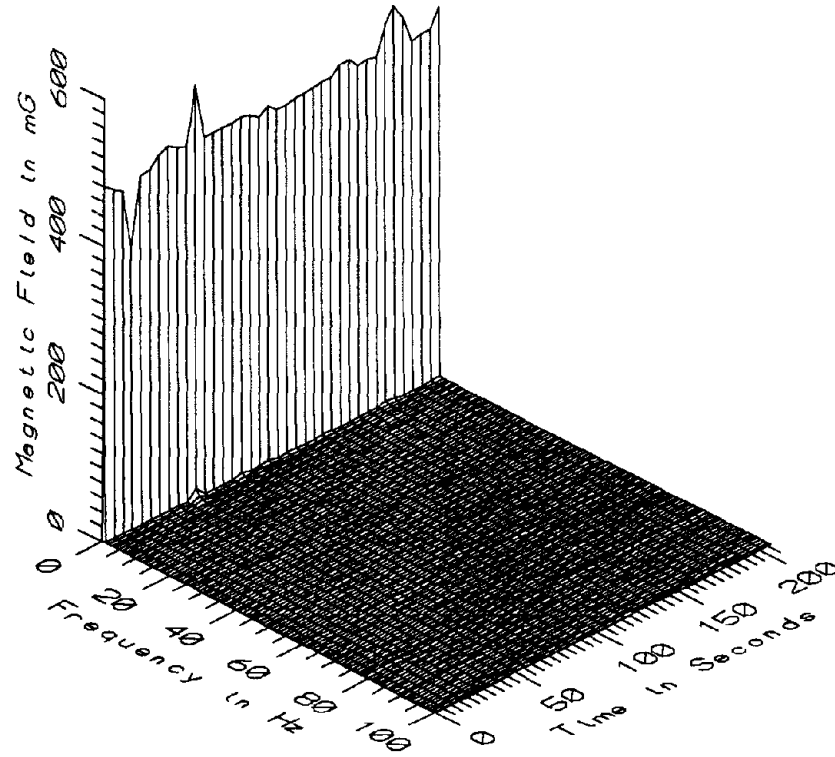

MET039 - 110cm FROM WEST WALL OF TRACTION POWER SUPPLY STATION

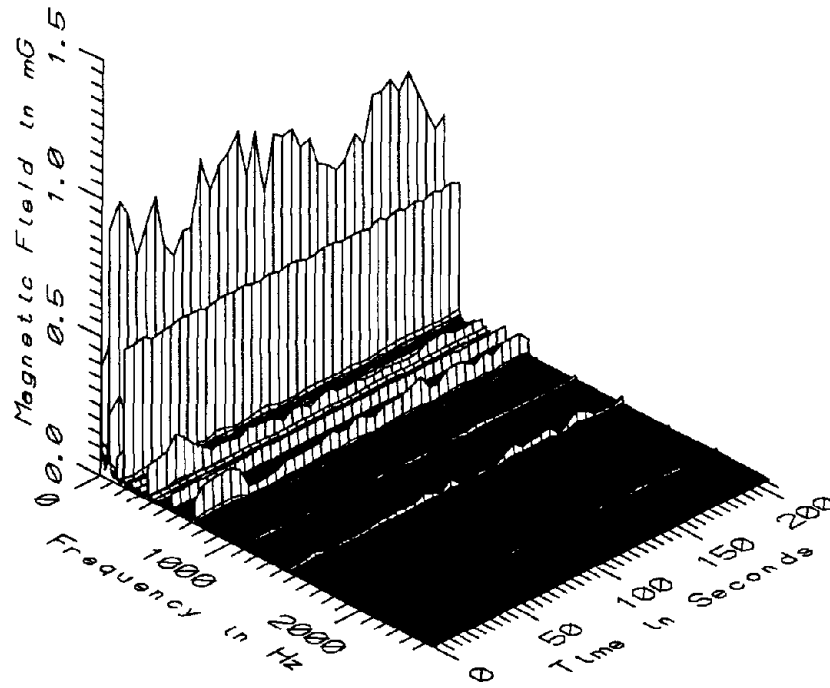

MET039 - 110cm FROM WEST WALL OF TRACTION POWER SUPPLY STATION

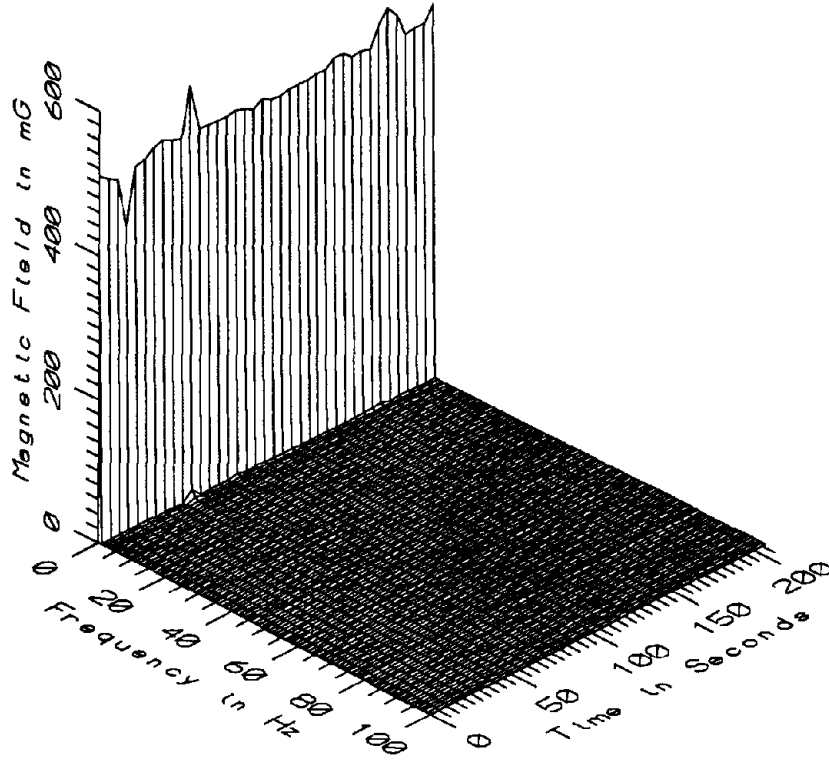

MET039 - 160cm FROM WEST WALL OF TRACTION POWER SUPPLY STATION

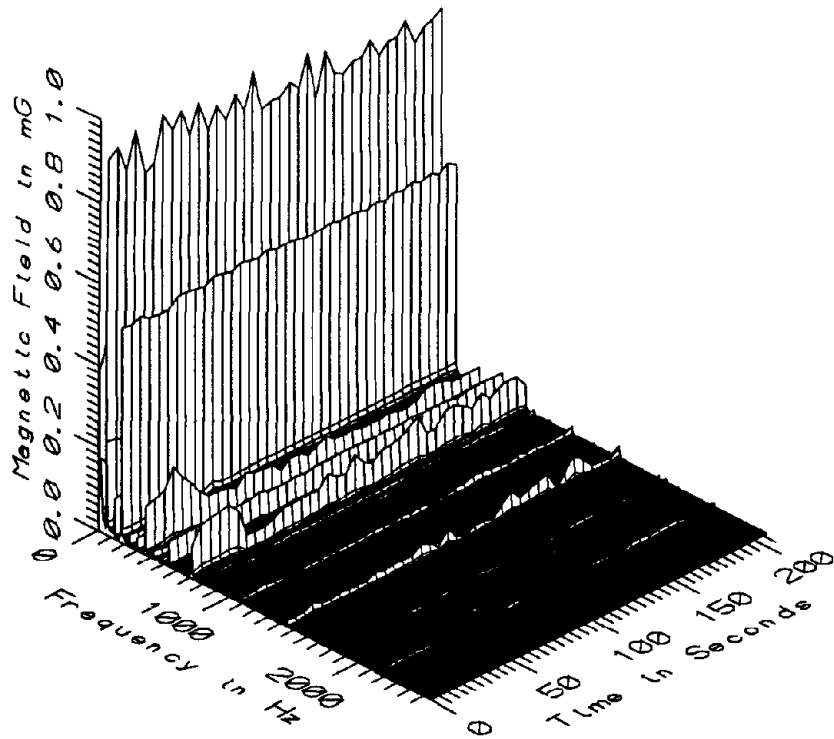

MET039 - 160cm FROM WEST WALL OF TRACTION POWER SUPPLY STATION

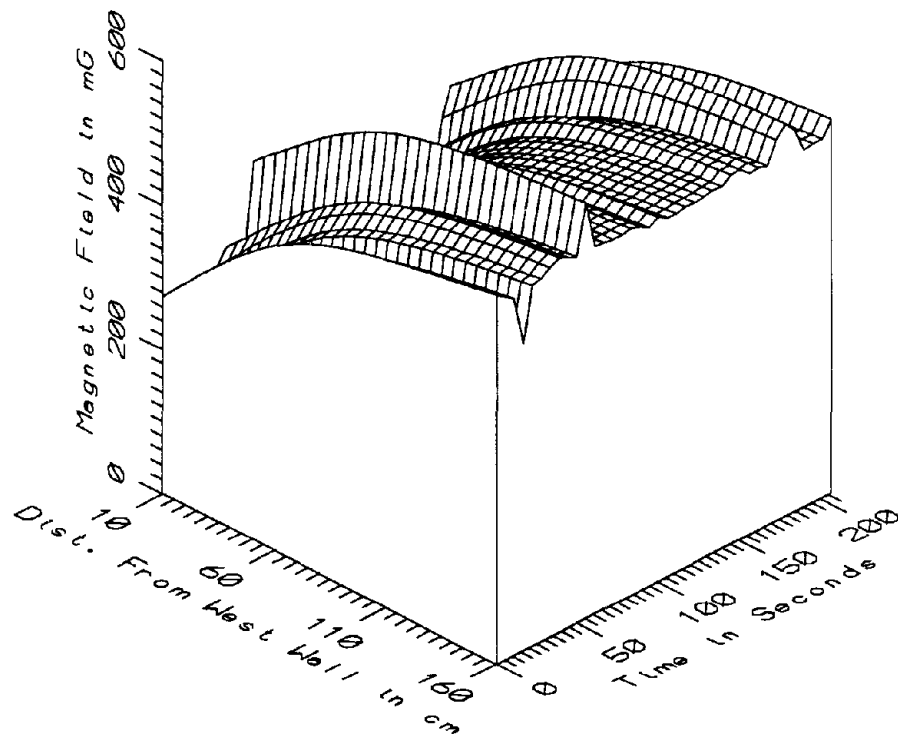

MET039 - TRACTION POWER SUPPLY STATION - STATIC

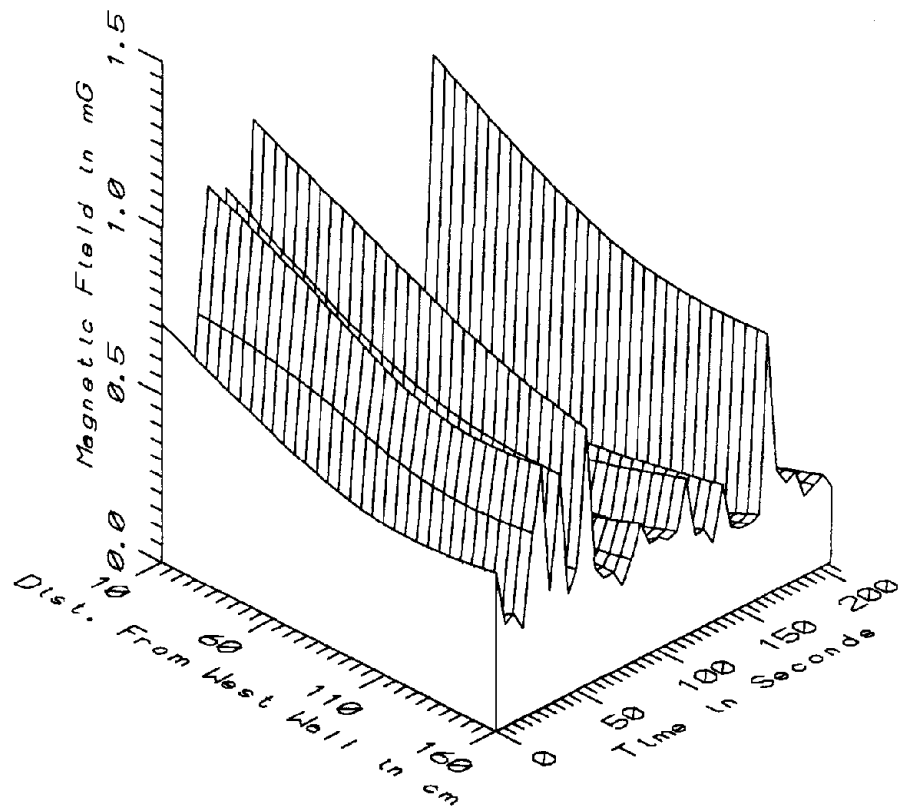

MET039 - TRACTION POWER SUPPLY STATION - LOW FREQ, 5-45Hz



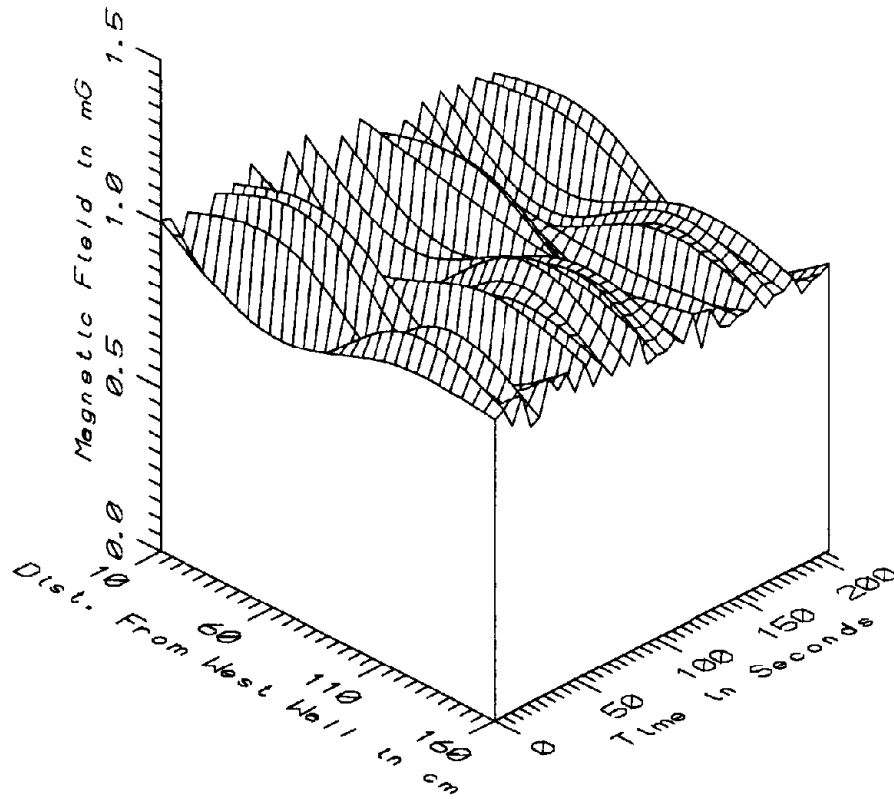

MET039 - TRACTION POWER SUPPLY STATION - POWER FREQ, 50-60Hz

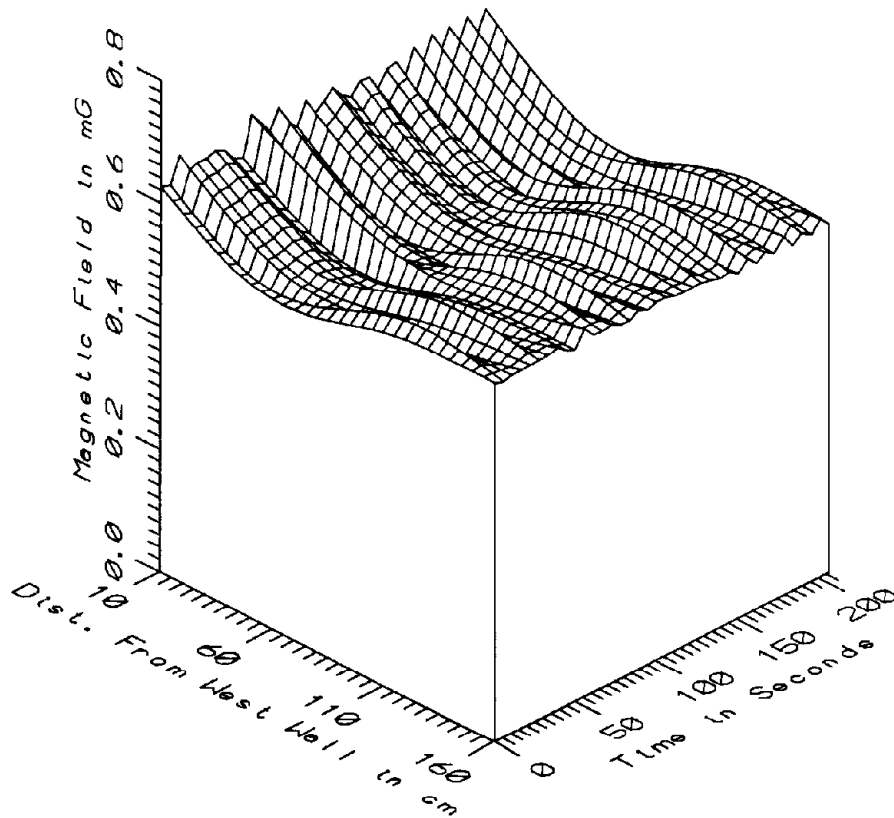

MET039 - TRACTION POWER SUPPLY STATION - POWER HARM, 65-300Hz

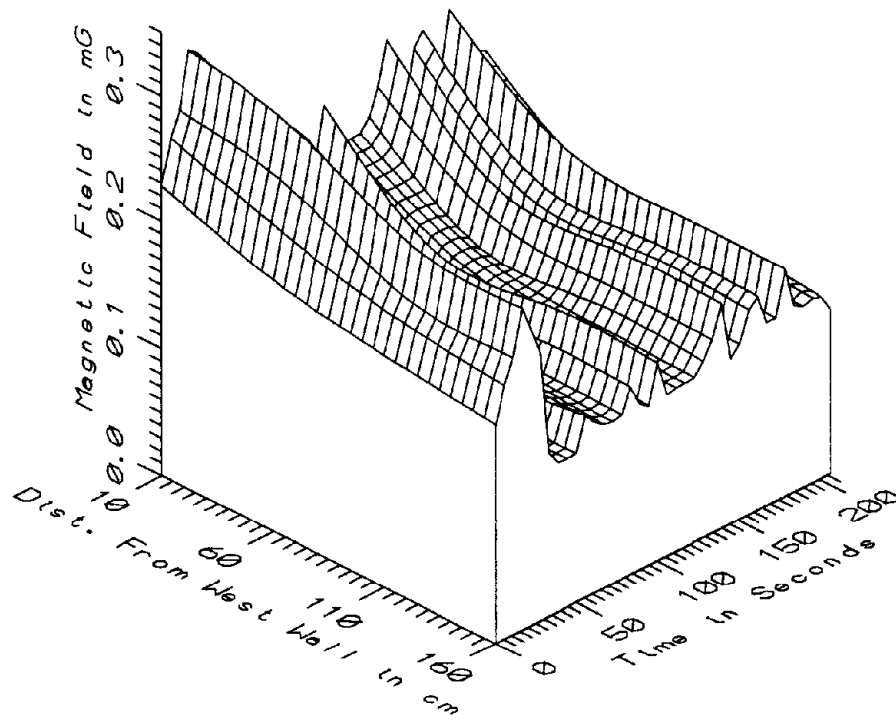

MET039 - TRACTION POWER SUPPLY STATION - HIGH FREQ, 305-2560Hz

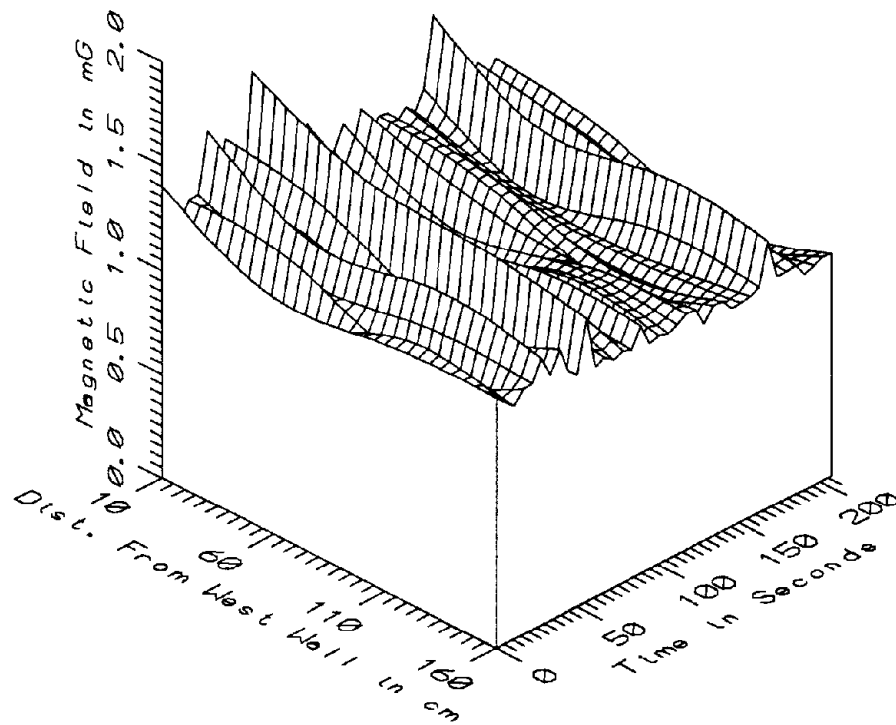

MET039 - TRACTION POWER SUPPLY STATION - ALL FREQ, 5-2560Hz

MET039 - T.P.S.S. SOUTH OF SHADY GROVE, FROM WEST WALL TOTAL OF 38 SAMPLES						
FREQUENCY BAND	DIST FROM WALL (cm)	MINIMUM MAGNETIC FIELD (mG)	MAXIMUM MAGNETIC FIELD (mG)	AVERAGE MAGNETIC FIELD (mG)	STANDARD DEVIATION (mG)	COEFFICIENT OF VARIATION (%)
STATIC	10	42.32	396.79	269.43	49.39	18.33
	60	280.45	516.33	416.59	32.48	7.80
	110	380.67	558.55	481.01	24.49	5.09
	160	423.29	572.71	504.95	20.26	4.01
5-45HZ	10	0.31	1.19	0.49	0.23	47.16
LOW FREQ	60	0.21	1.03	0.37	0.21	56.08
	110	0.14	0.87	0.30	0.18	61.96
	160	0.22	0.78	0.36	0.15	40.92
50-60HZ	10	0.80	1.05	0.91	0.08	8.86
PWR FREQ	60	0.67	1.05	0.82	0.11	13.80
	110	0.70	1.04	0.87	0.10	11.14
	160	0.81	0.96	0.88	0.04	4.45
65-300HZ	10	0.61	0.67	0.63	0.02	2.69
PWR HARM	60	0.51	0.58	0.53	0.01	2.48
	110	0.53	0.59	0.56	0.02	3.04
	160	0.56	0.60	0.58	0.01	1.22
305-2560HZ	10	0.17	0.33	0.22	0.04	16.54
HIGH FREQ	60	0.12	0.30	0.16	0.05	27.68
	110	0.12	0.26	0.15	0.03	22.03
	160	0.12	0.25	0.15	0.03	21.74
5-2560HZ	10	1.11	1.73	1.25	0.14	10.90
ALL FREQ	60	0.91	1.49	1.07	0.13	11.93
	110	0.92	1.44	1.10	0.12	10.53
	160	1.04	1.36	1.13	0.07	6.39

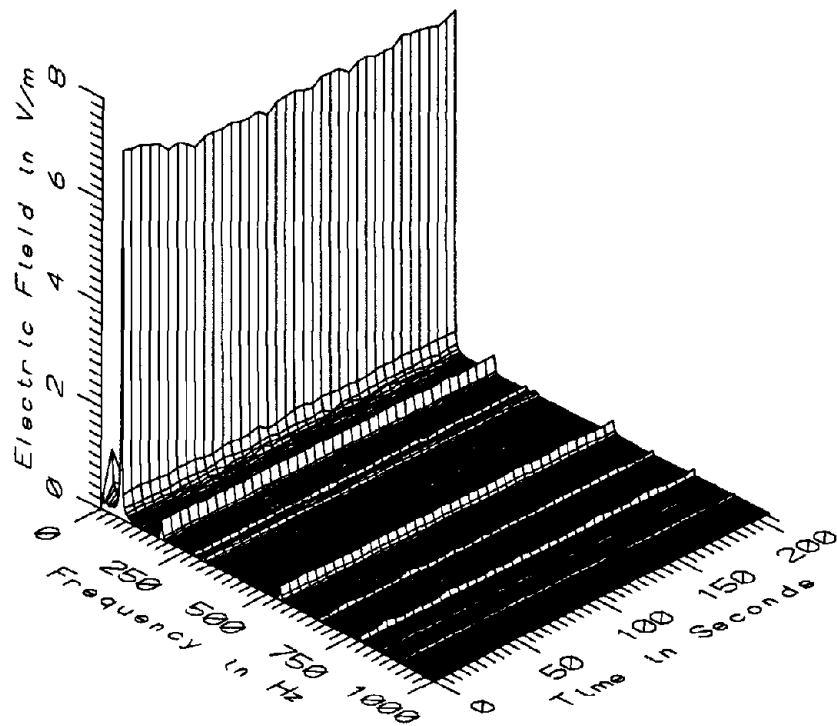

MET039 - ELECTRIC FIELD AT TRACTION POWER SUPPLY STATION

APPENDIX AJ

DATASET MET040

AT TRACTION POWER SUPPLY STATION SOUTH OF SHADY GROVE

Measurement Setup Code:        Staff:     40    Reference: -  
   Drawing:  A-6

Vehicle Status:                NA

Measurement Date:             May 20, 1992

Measurement Time:            Start:     08:49:40  
   End:        08:55:56

Number of Samples:            62

Programmed Sample Interval:   5 sec

Actual Sample Interval:       6.2 sec

Frequency Spectrum Parameters

<u>Probe Type:</u>	<u>Wideband</u>	<u>Static</u>
Maximum Frequency (Hz)	2560	100
Minimum Frequency (Hz)	5	0
Spectral Bandwidth (Hz)	5	1

Missing Data: No reference probe

Saturated Data: None

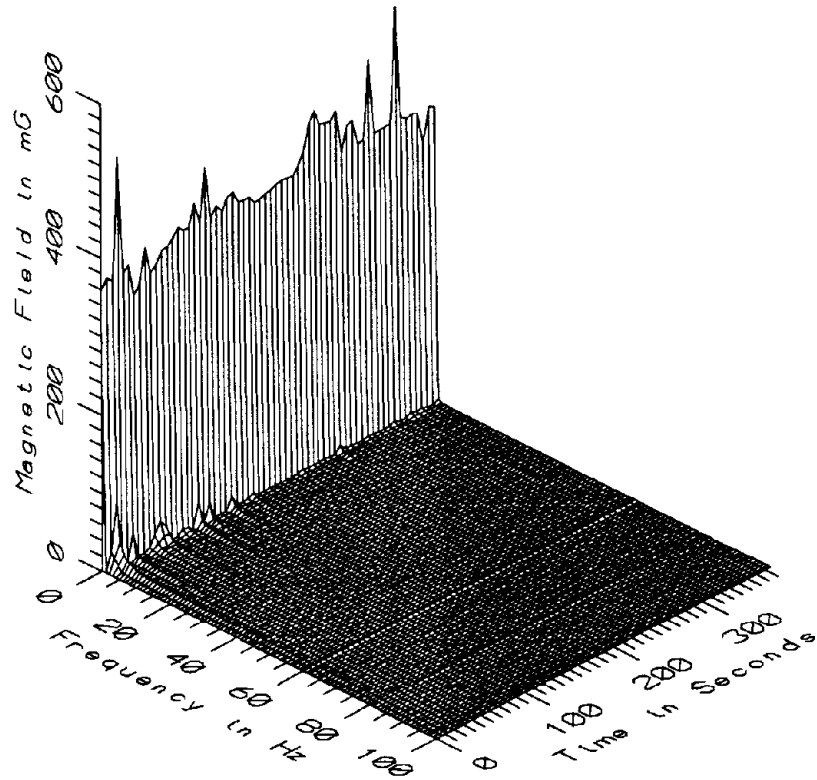

MET040 - 10cm FROM WEST WALL OF TRACTION POWER SUPPLY STATION

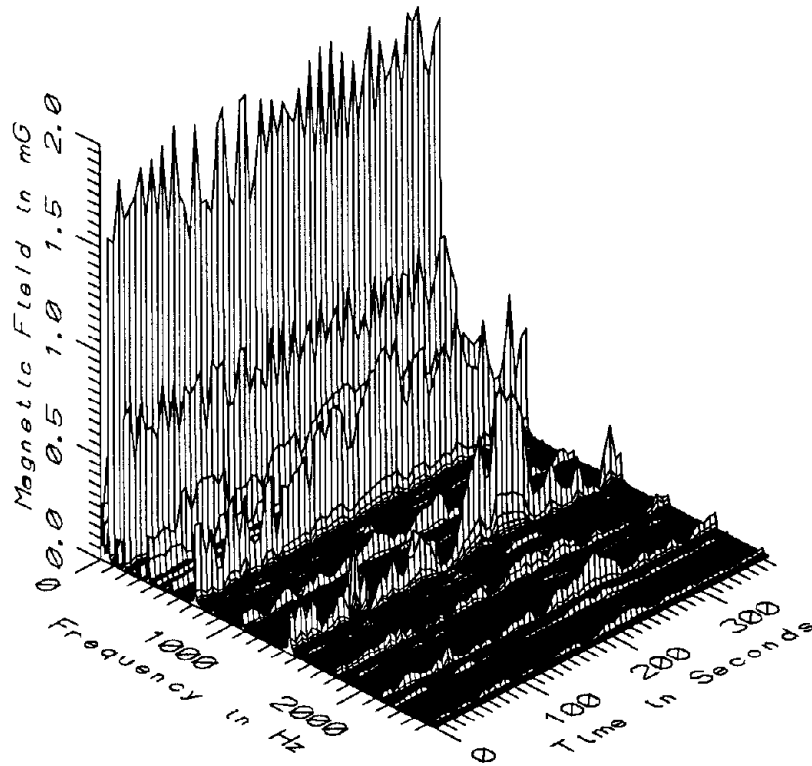

MET040 - 10cm FROM WEST WALL OF TRACTION POWER SUPPLY STATION

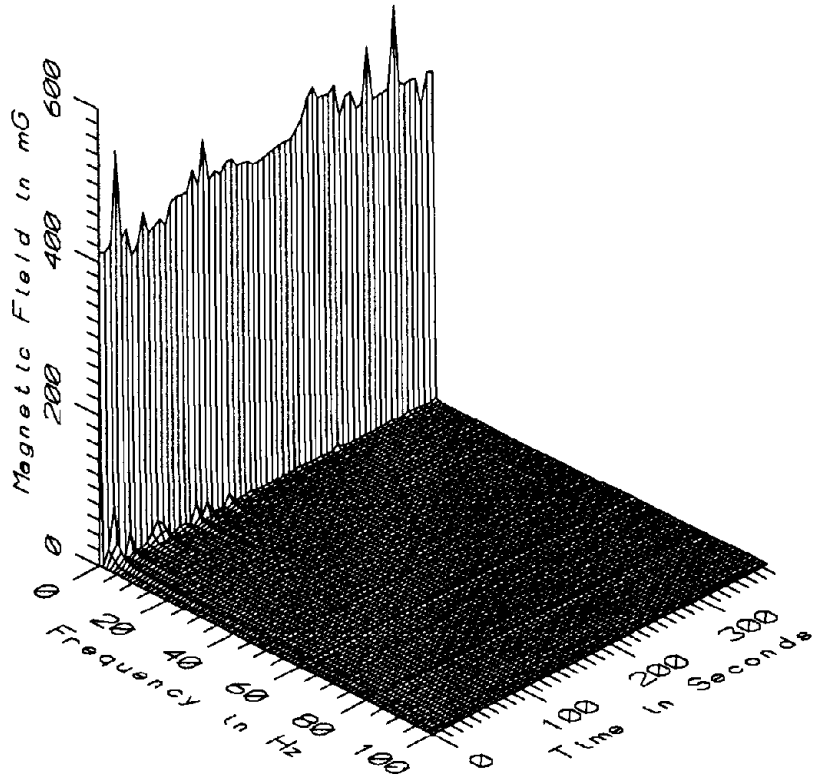

MET040 - 60cm FROM WEST WALL OF TRACTION POWER SUPPLY STATION

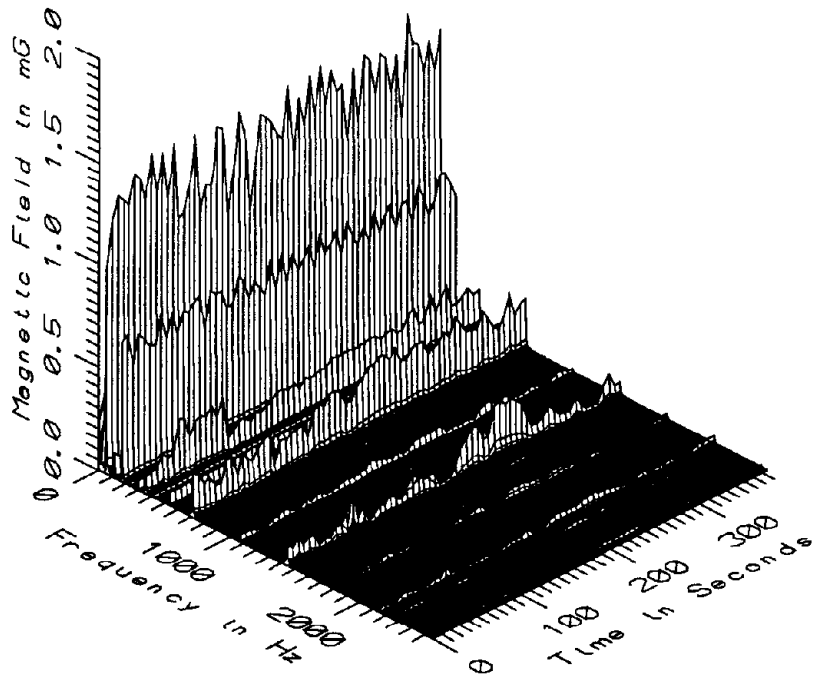

MET040 - 60cm FROM WEST WALL OF TRACTION POWER SUPPLY STATION

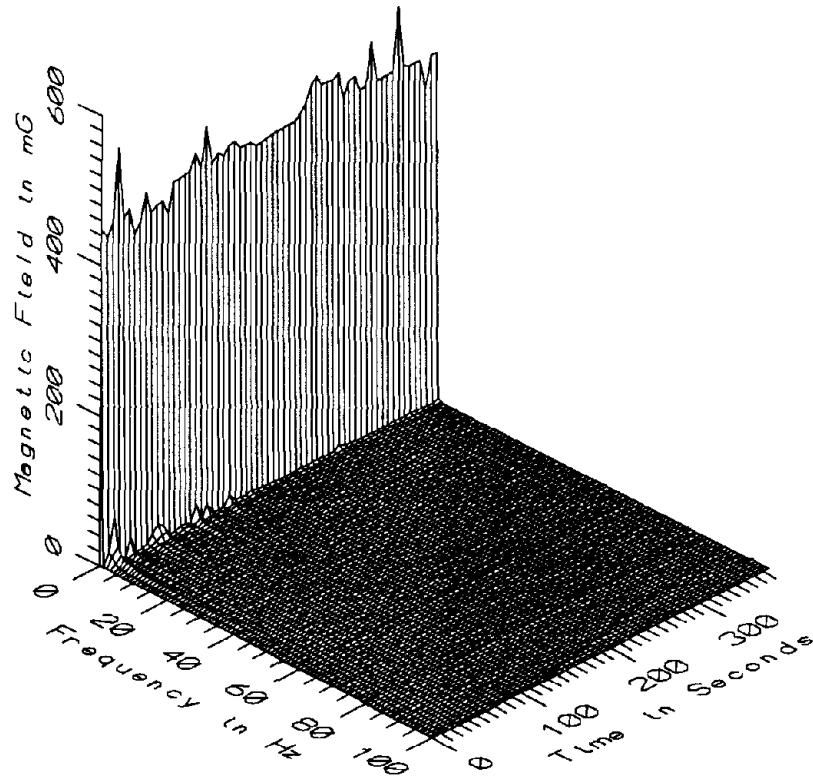

MET040 - 110cm FROM WEST WALL OF TRACTION POWER SUPPLY STATION

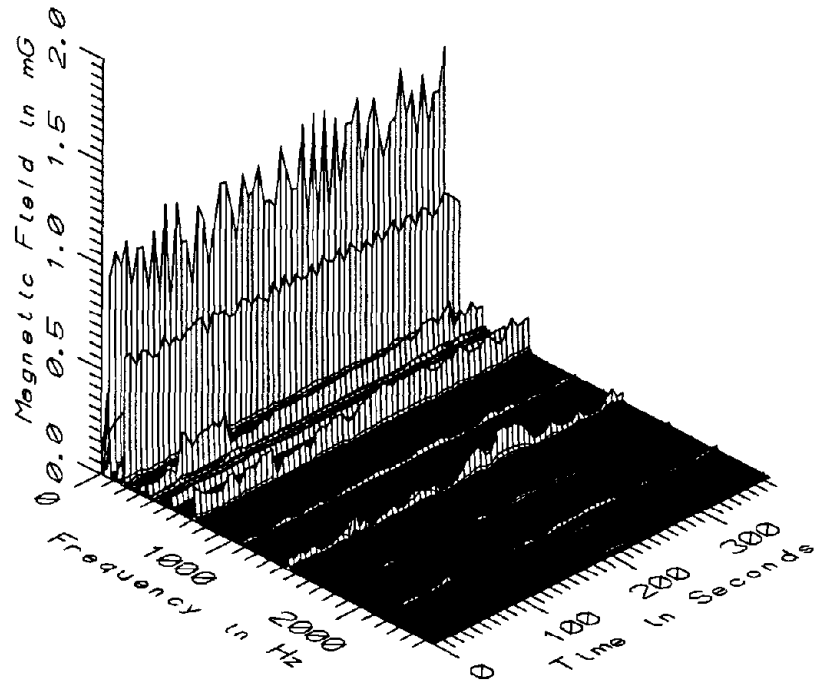

MET040 - 110cm FROM WEST WALL OF TRACTION POWER SUPPLY STATION



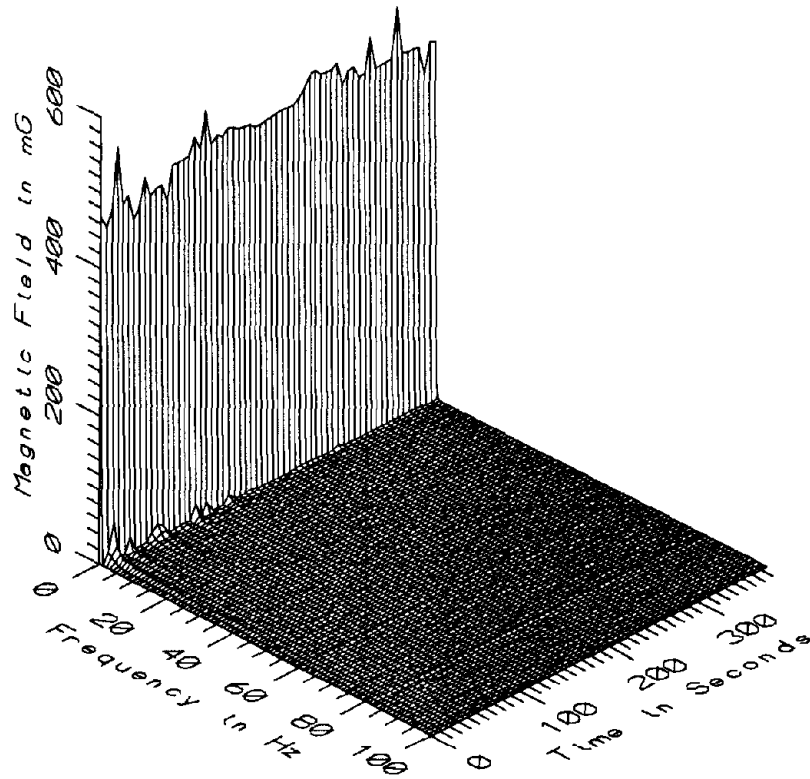

MET040 - 160cm FROM WEST WALL OF TRACTION POWER SUPPLY STATION

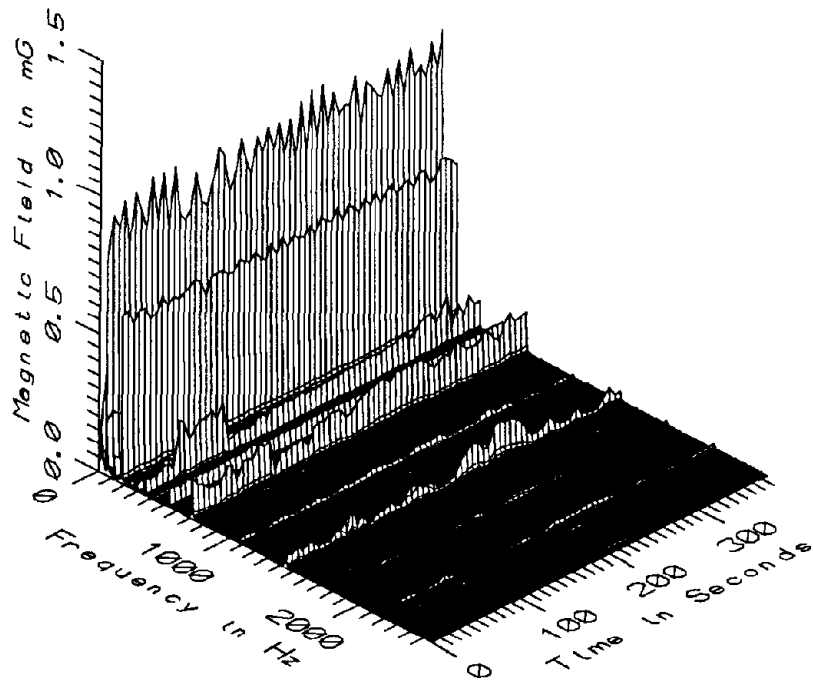

MET040 - 160cm FROM WEST WALL OF TRACTION POWER SUPPLY STATION

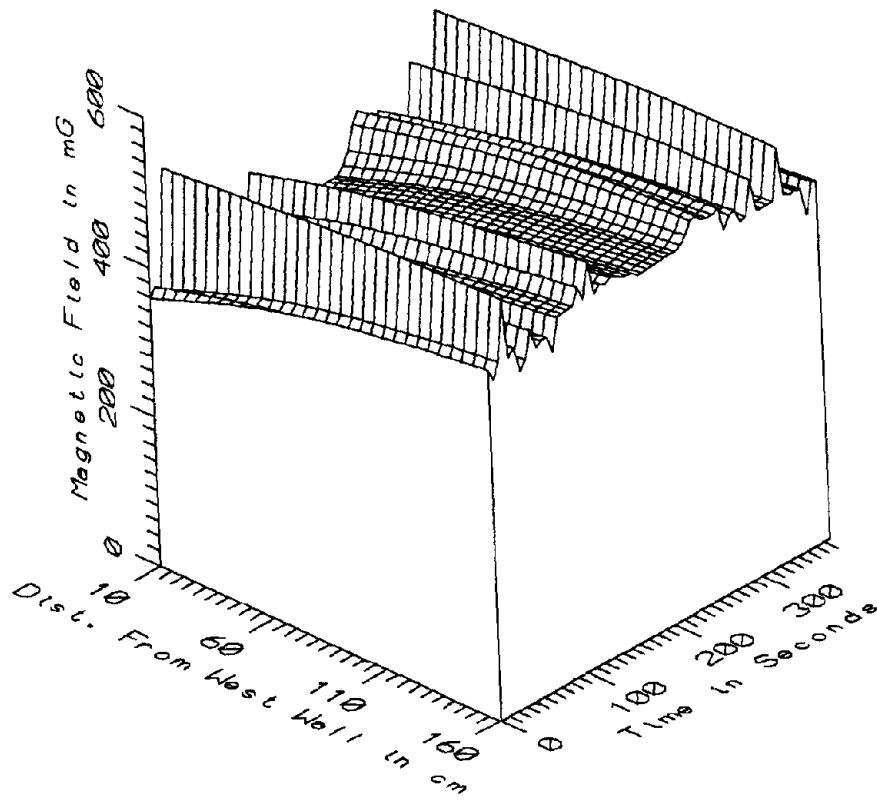

MET040 - TRACTION POWER SUPPLY STATION - STATIC

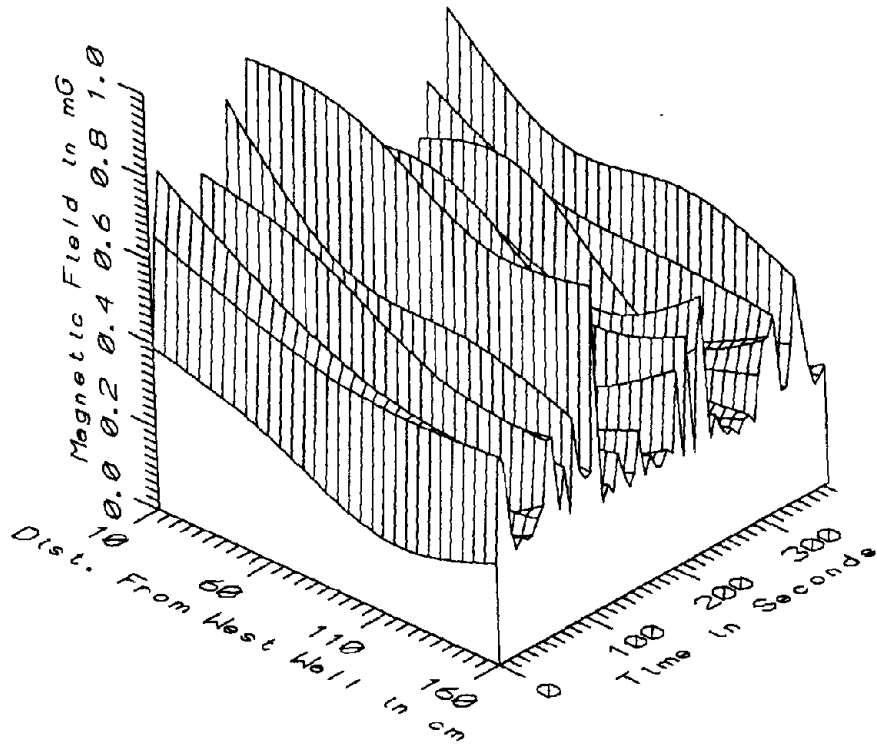

MET040 - TRACTION POWER SUPPLY STATION - LOW FREQ. 5-45Hz

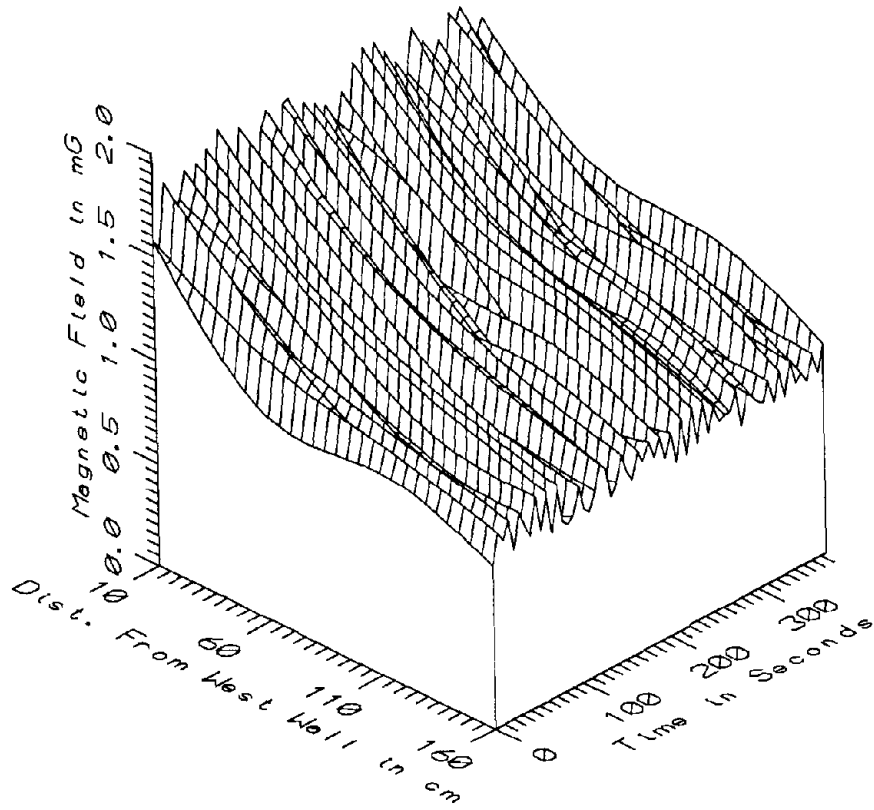

MET040 - TRACTION POWER SUPPLY STATION - POWER FREQ, 50-60Hz

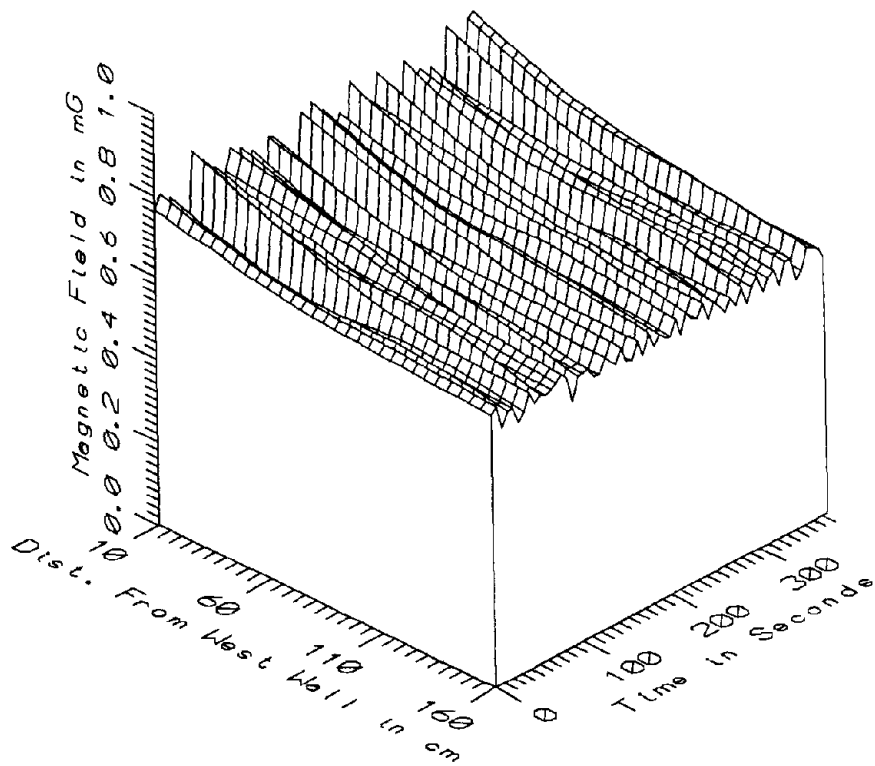

MET040 - TRACTION POWER SUPPLY STATION - POWER HARM, 65-300Hz

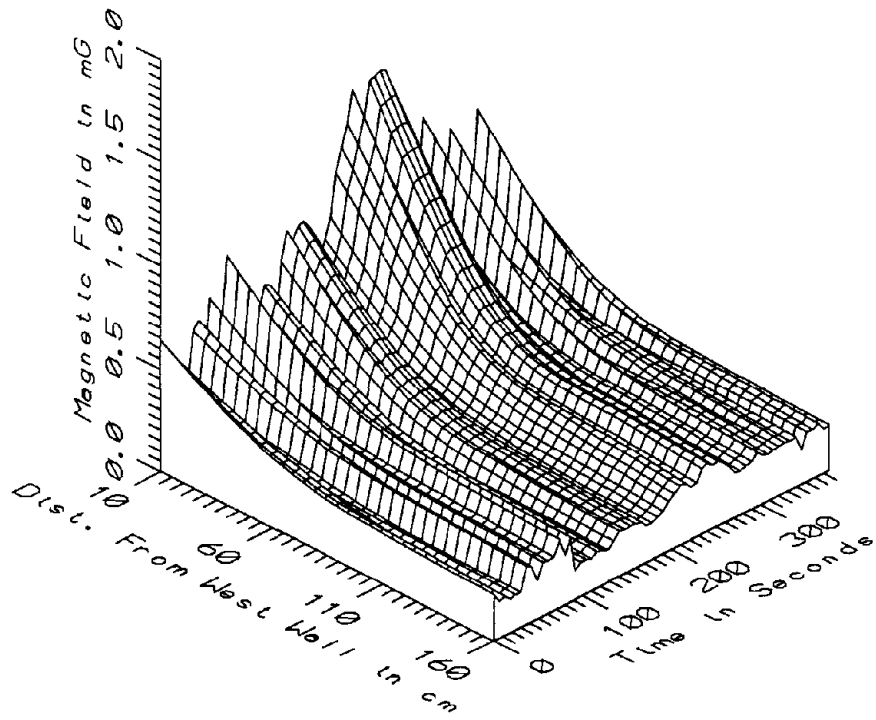

MET040 - TRACTION POWER SUPPLY STATION - HIGH FREQ, 305-2560Hz

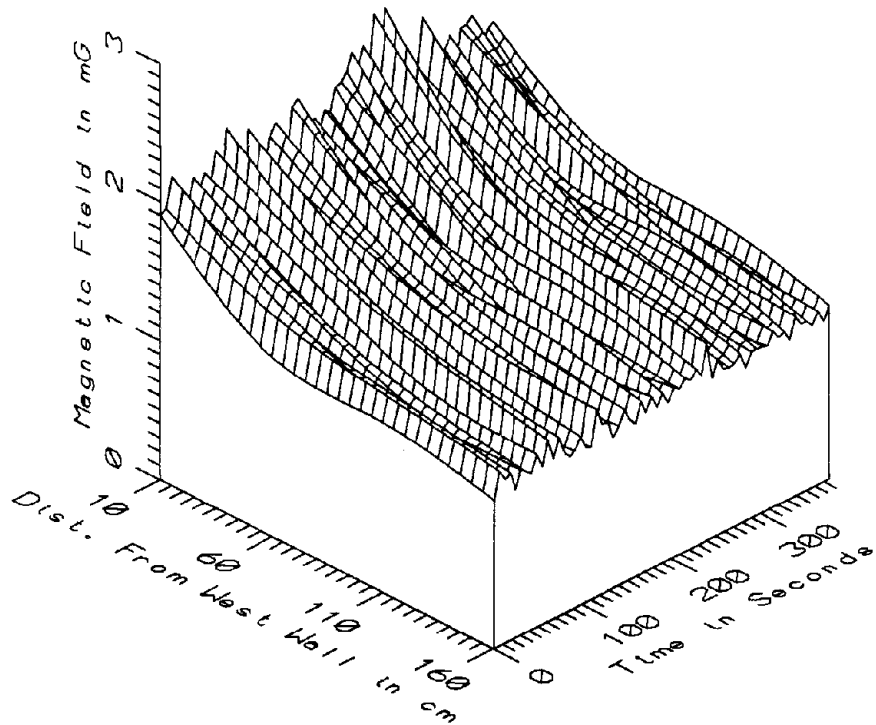

MET040 - TRACTION POWER SUPPLY STATION - ALL FREQ, 5-2560Hz

MET040 - T.P.S.S. SOUTH OF SHADY GROVE, FROM WEST WALL TOTAL OF 62 SAMPLES						
FREQUENCY BAND	DIST FROM WALL (cm)	MINIMUM MAGNETIC FIELD (mG)	MAXIMUM MAGNETIC FIELD (mG)	AVERAGE MAGNETIC FIELD (mG)	STANDARD DEVIATION (mG)	COEFFICIENT OF VARIATION (%)
STATIC	10	331.72	529.01	391.90	36.15	9.22
	60	387.63	539.44	439.28	28.58	6.51
	110	421.59	548.71	469.60	24.84	5.29
	160	442.89	551.05	489.73	21.74	4.44
5-45Hz	10	0.30	0.95	0.45	0.15	32.41
LOW FREQ	60	0.21	0.92	0.34	0.14	41.60
	110	0.15	0.76	0.27	0.13	48.68
	160	0.24	0.78	0.34	0.11	32.18
50-60Hz	10	1.35	1.97	1.69	0.18	10.83
PWR FREQ	60	0.94	1.50	1.27	0.14	11.05
	110	0.71	1.28	1.03	0.15	14.65
	160	0.78	1.04	0.91	0.07	8.15
65-300Hz	10	0.51	0.86	0.69	0.11	16.12
PWR HARM	60	0.56	0.75	0.66	0.06	9.14
	110	0.58	0.71	0.65	0.04	5.40
	160	0.59	0.67	0.63	0.02	3.16
305-2560Hz	10	0.28	1.40	0.79	0.28	36.01
HIGH FREQ	60	0.15	0.56	0.37	0.09	25.36
	110	0.14	0.38	0.26	0.06	22.02
	160	0.14	0.33	0.23	0.05	21.18
5-2560Hz	10	1.72	2.58	2.07	0.18	8.75
ALL FREQ	60	1.20	1.81	1.53	0.12	7.78
	110	1.05	1.55	1.29	0.12	9.06
	160	1.07	1.41	1.19	0.07	5.55

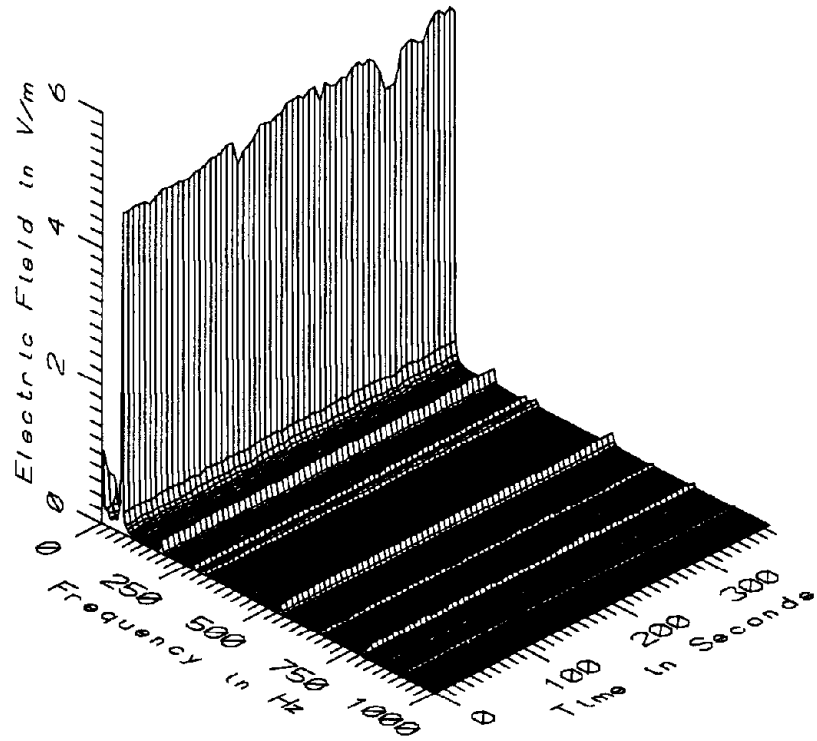

MET040 - ELECTRIC FIELD AT TRACTION POWER SUPPLY STATION

APPENDIX AK

DATASET MET041

AT TRACTION POWER SUPPLY STATION SOUTH OF SHADY GROVE

Measurement Setup Code:      Staff:    42    Reference: -  
   Drawing:  A-6

Vehicle Status:                NA

Measurement Date:             May 20, 1992

Measurement Time:            Start:    08:58:42  
   End:      09:02:21

Number of Samples:            39

Programmed Sample Interval:   5 sec

Actual Sample Interval:       5.6 sec

Frequency Spectrum Parameters

<u>Probe Type:</u>	<u>Wideband</u>	<u>Static</u>
Maximum Frequency (Hz)	2560	100
Minimum Frequency (Hz)	5	0
Spectral Bandwidth (Hz)	5	1

Missing Data: No reference probe

Saturated Data: None

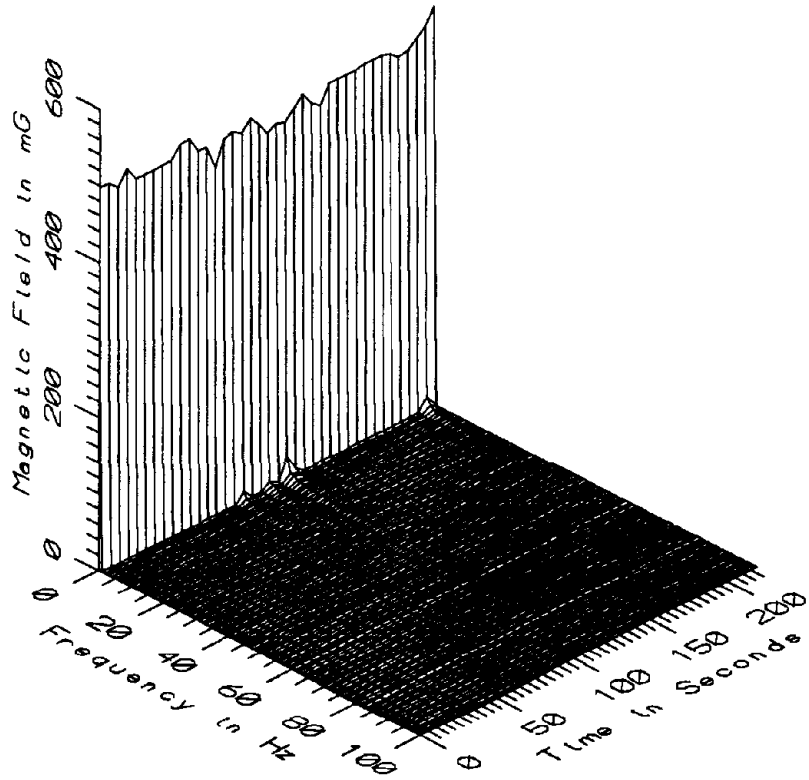

MET041 - 10cm FROM WEST WALL OF TRACTION POWER SUPPLY STATION

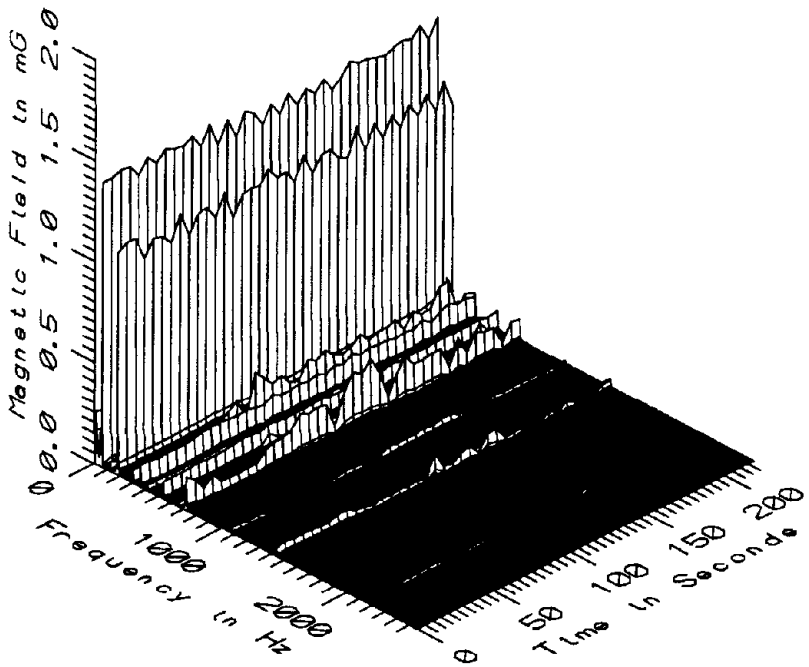

MET041 - 10cm FROM WEST WALL OF TRACTION POWER SUPPLY STATION



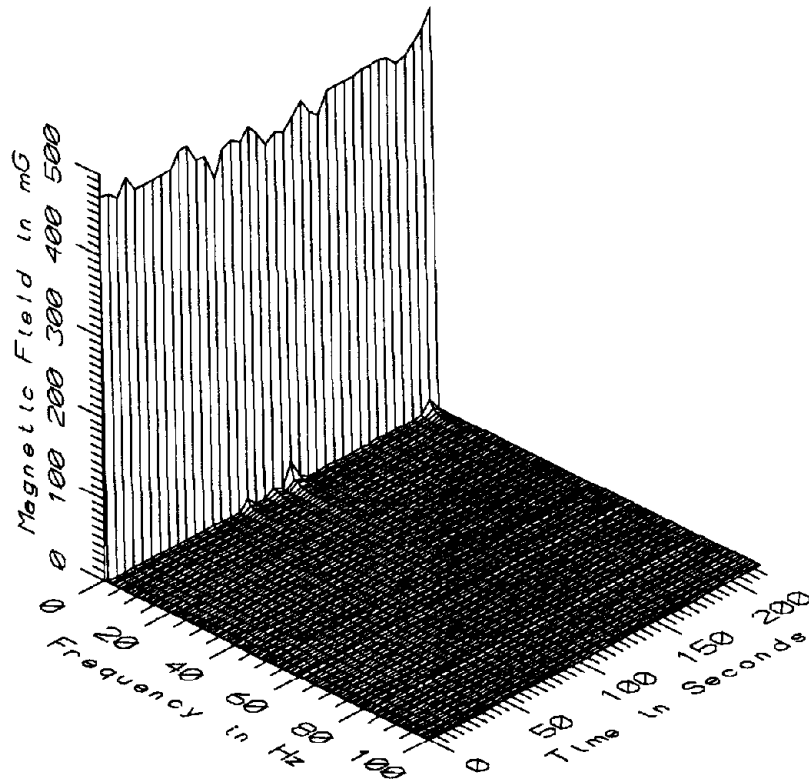

MET041 - 60cm FROM WEST WALL OF TRACTION POWER SUPPLY STATION

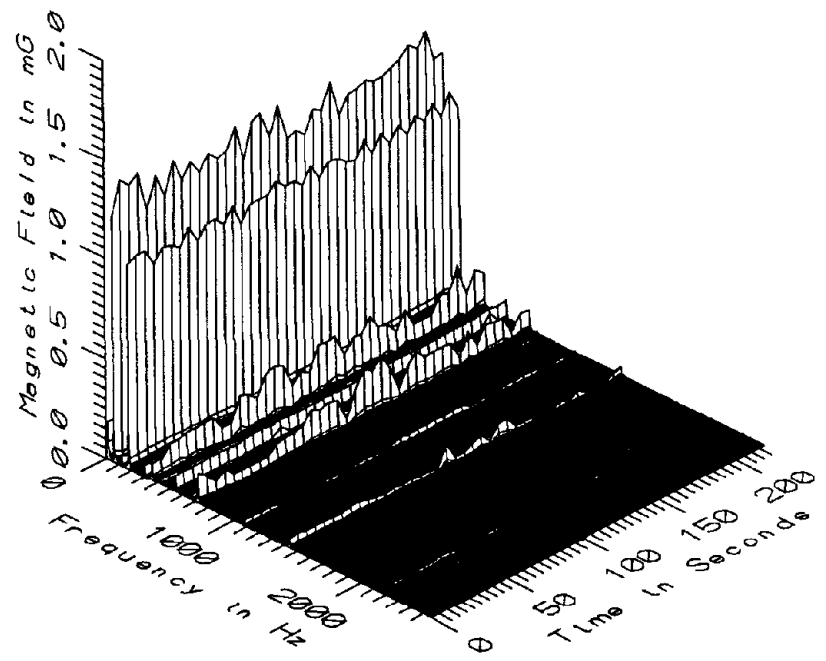

MET041 - 60cm FROM WEST WALL OF TRACTION POWER SUPPLY STATION

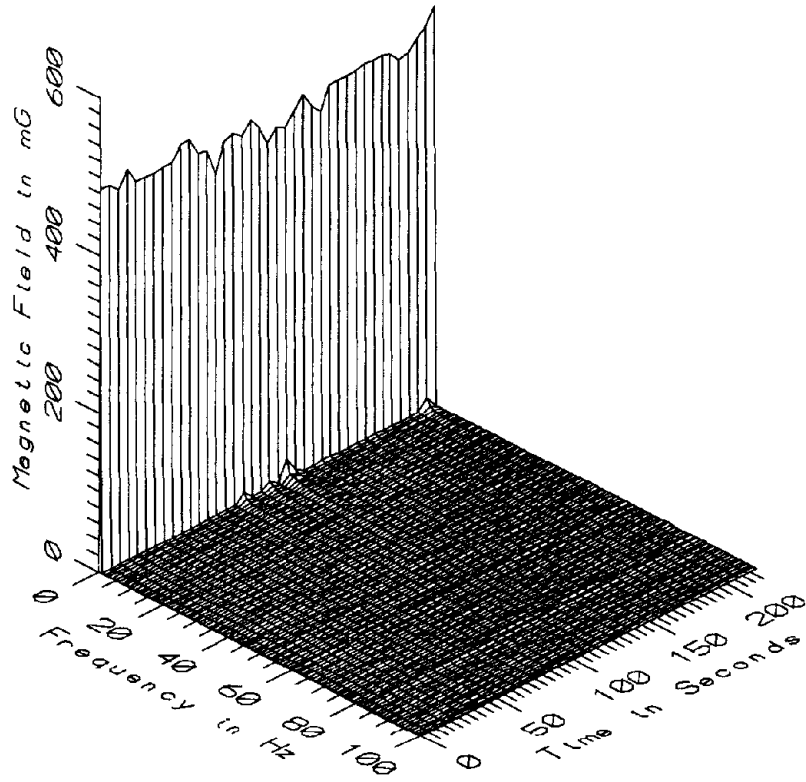

MET041 - 110cm FROM WEST WALL OF TRACTION POWER SUPPLY STATION

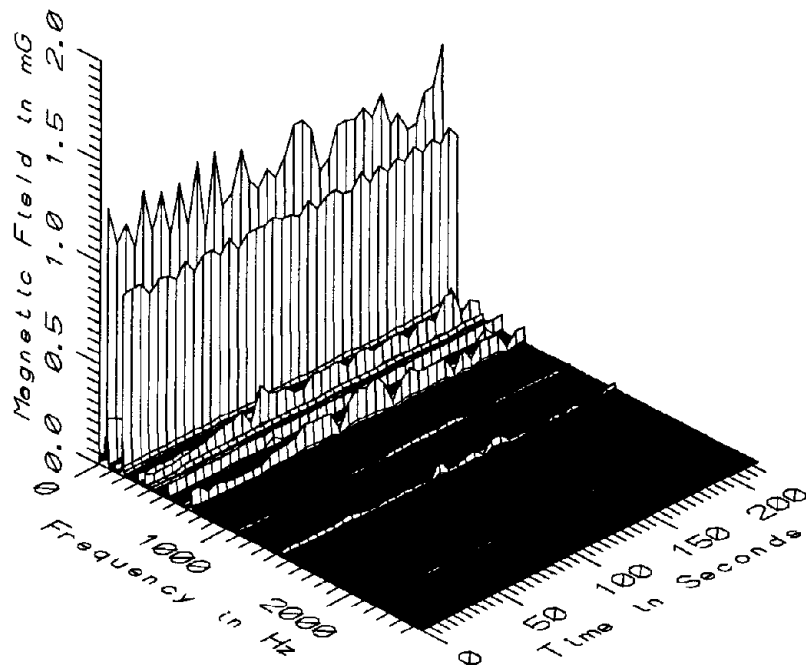

MET041 - 110cm FROM WEST WALL OF TRACTION POWER SUPPLY STATION

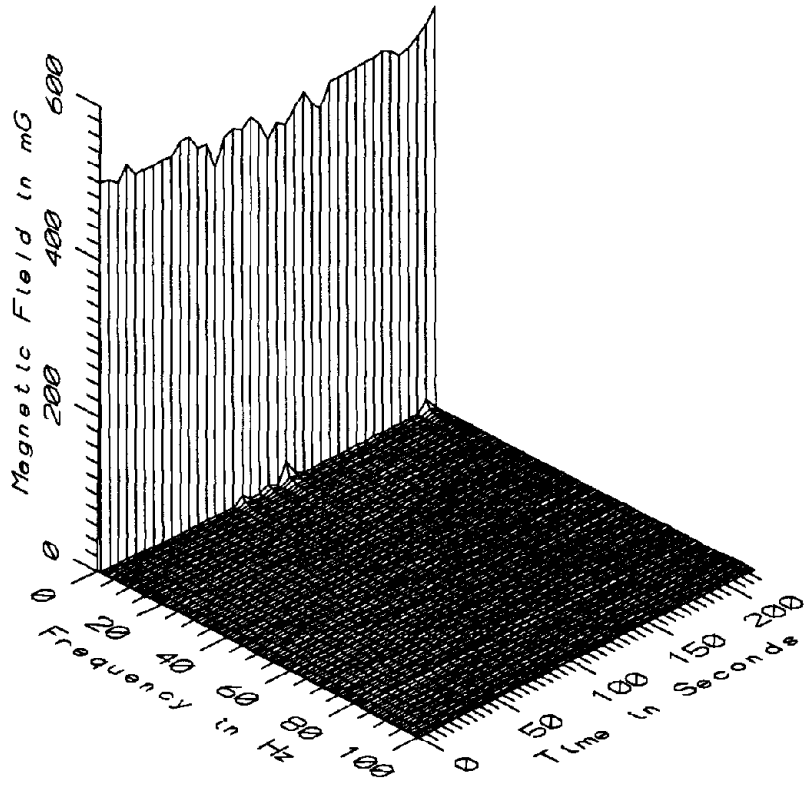

MET041 - 160cm FROM WEST WALL OF TRACTION POWER SUPPLY STATION

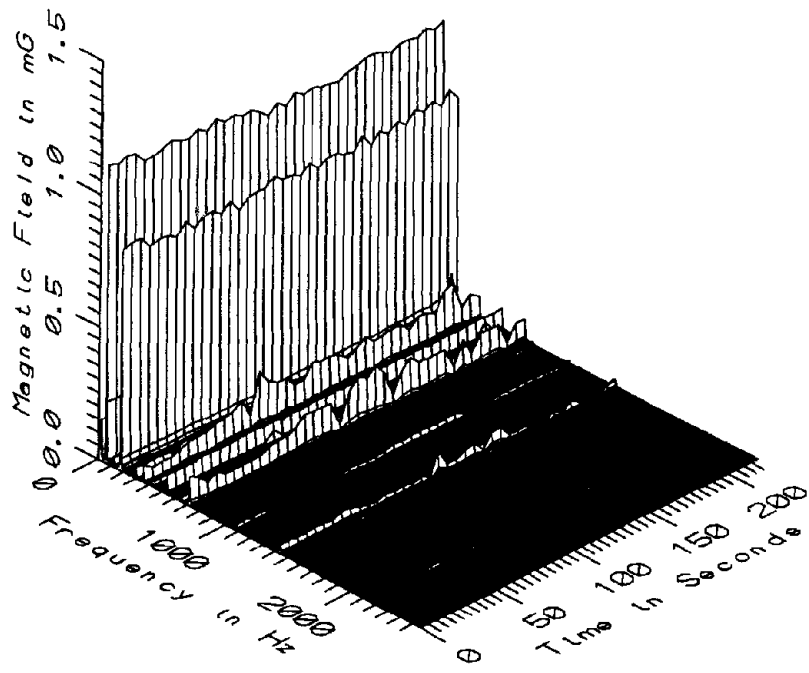

MET041 - 160cm FROM WEST WALL OF TRACTION POWER SUPPLY STATION

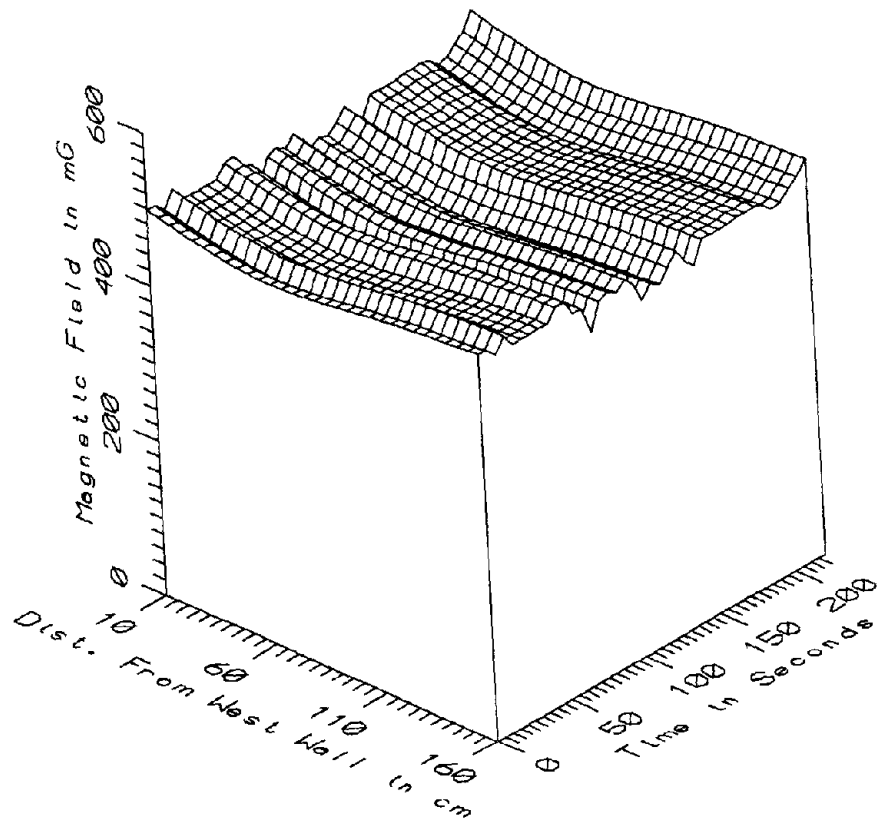

MET041 - TRACTION POWER SUPPLY STATION - STATIC

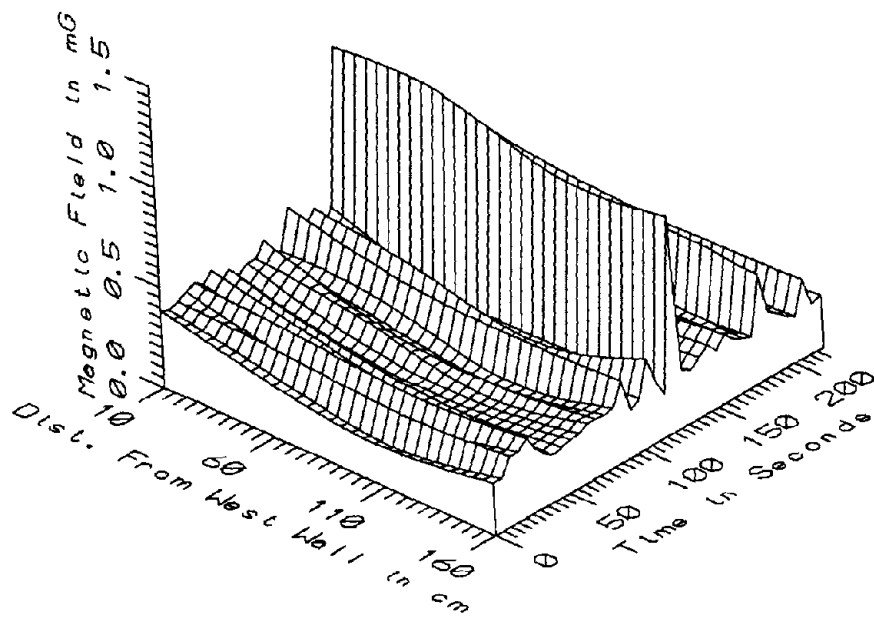

MET041 - TRACTION POWER SUPPLY STATION - LOW FREQ, 5-45Hz

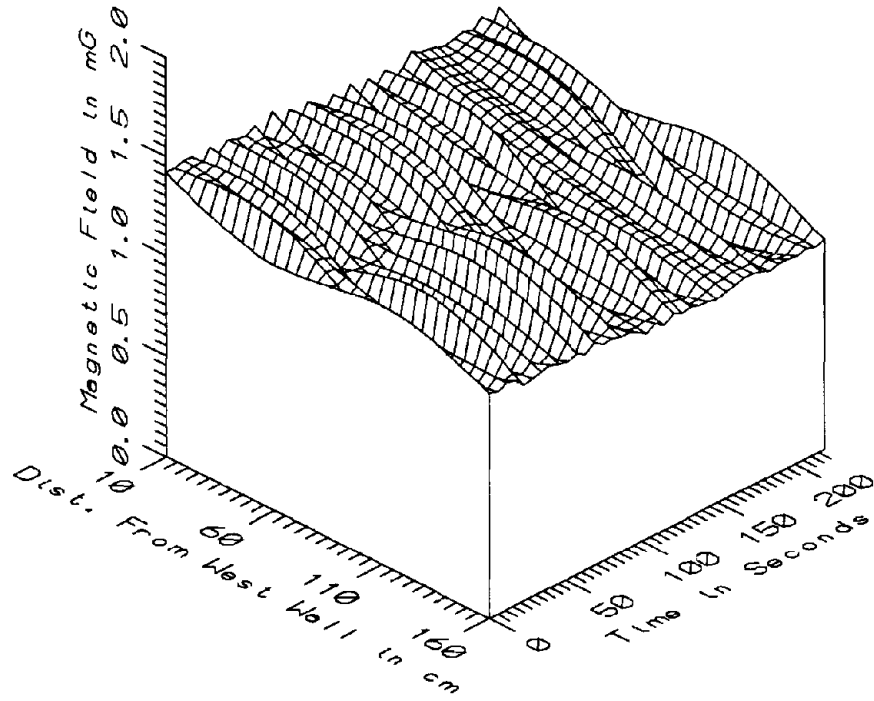

MET041 - TRACTION POWER SUPPLY STATION - POWER FREQ, 50-60Hz

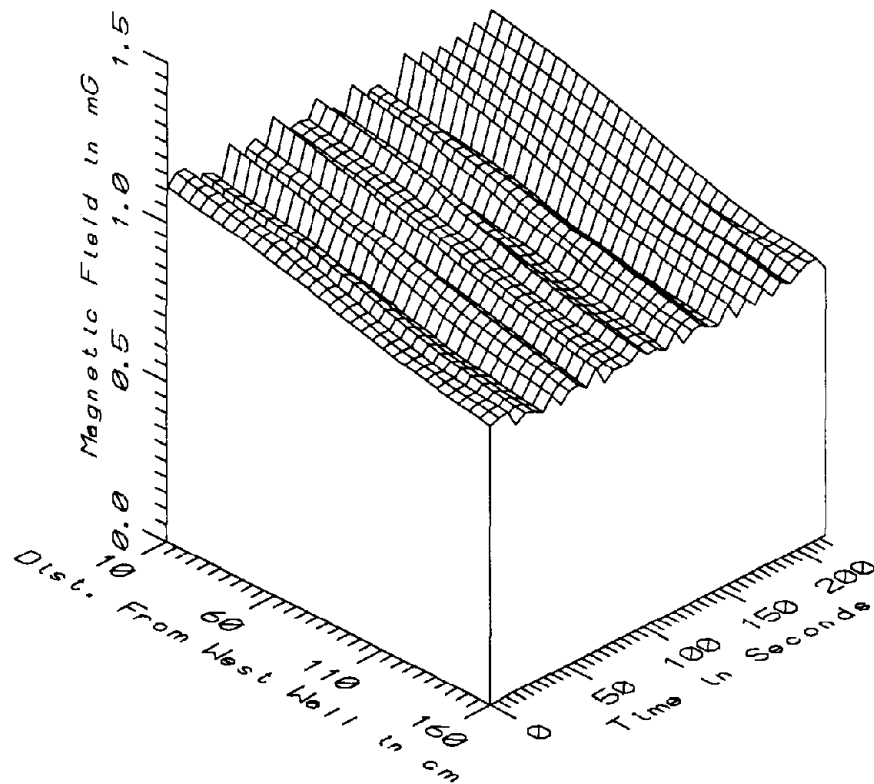

MET041 - TRACTION POWER SUPPLY STATION - POWER HARM, 65-300Hz

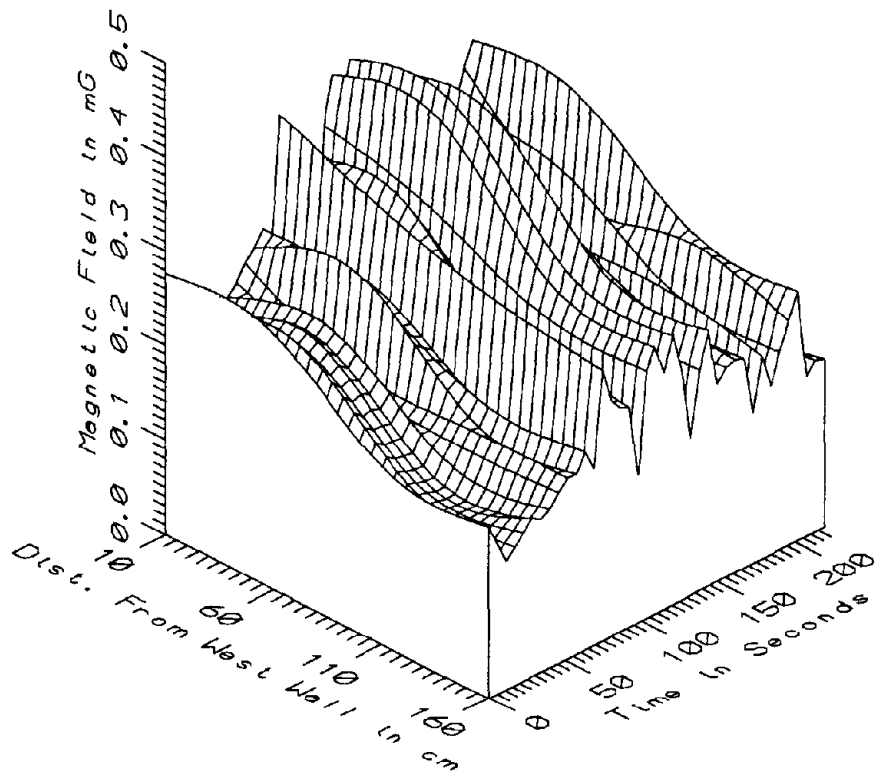

MET041 - TRACTION POWER SUPPLY STATION - HIGH FREQ, 305-2560Hz

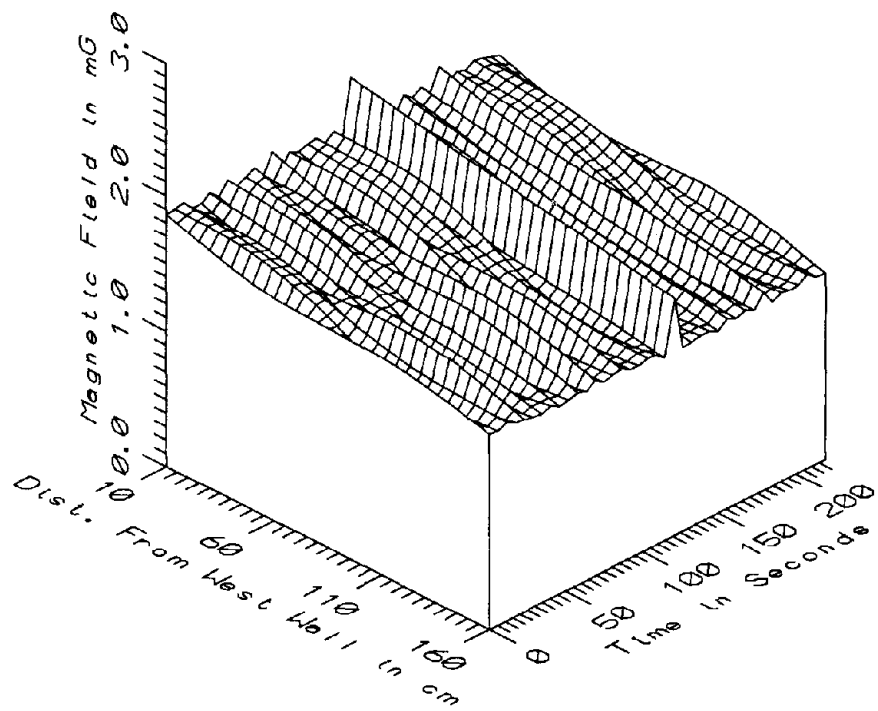

MET041 - TRACTION POWER SUPPLY STATION - ALL FREQ, 5-2560Hz

MET041 - T.P.S.S. SOUTH OF SHADY GROVE, FROM WEST WALL TOTAL OF 39 SAMPLES						
FREQUENCY BAND	DIST FROM WALL (cm)	MINIMUM MAGNETIC FIELD (mG)	MAXIMUM MAGNETIC FIELD (mG)	AVERAGE MAGNETIC FIELD (mG)	STANDARD DEVIATION (mG)	COEFFICIENT OF VARIATION (%)
STATIC	10	450.14	517.88	483.97	13.24	2.73
	60	421.26	490.41	456.48	13.86	3.04
	110	432.24	503.75	470.15	14.75	3.14
	160	447.02	512.36	483.73	14.36	2.97
5-45Hz LOW FREQ	10	0.31	1.18	0.43	0.14	33.05
	60	0.20	1.19	0.31	0.16	52.72
	110	0.17	1.03	0.26	0.15	57.04
	160	0.21	1.07	0.32	0.14	44.29
50-60Hz PWR FREQ	10	1.31	1.46	1.38	0.04	2.99
	60	1.15	1.39	1.26	0.07	5.46
	110	0.92	1.32	1.11	0.11	10.18
	160	1.01	1.13	1.06	0.03	3.26
65-300Hz PWR HARM	10	1.01	1.16	1.09	0.05	4.52
	60	0.96	1.07	1.02	0.03	3.43
	110	0.87	0.96	0.92	0.02	2.60
	160	0.82	0.89	0.85	0.02	2.30
305-2560Hz HIGH FREQ	10	0.20	0.41	0.28	0.06	21.16
	60	0.17	0.41	0.27	0.06	22.25
	110	0.14	0.30	0.21	0.05	22.86
	160	0.14	0.28	0.20	0.04	20.68
5-2560Hz ALL FREQ	10	1.72	2.19	1.83	0.08	4.11
	60	1.55	2.03	1.68	0.08	4.99
	110	1.33	1.90	1.49	0.11	7.48
	160	1.35	1.76	1.42	0.07	4.62

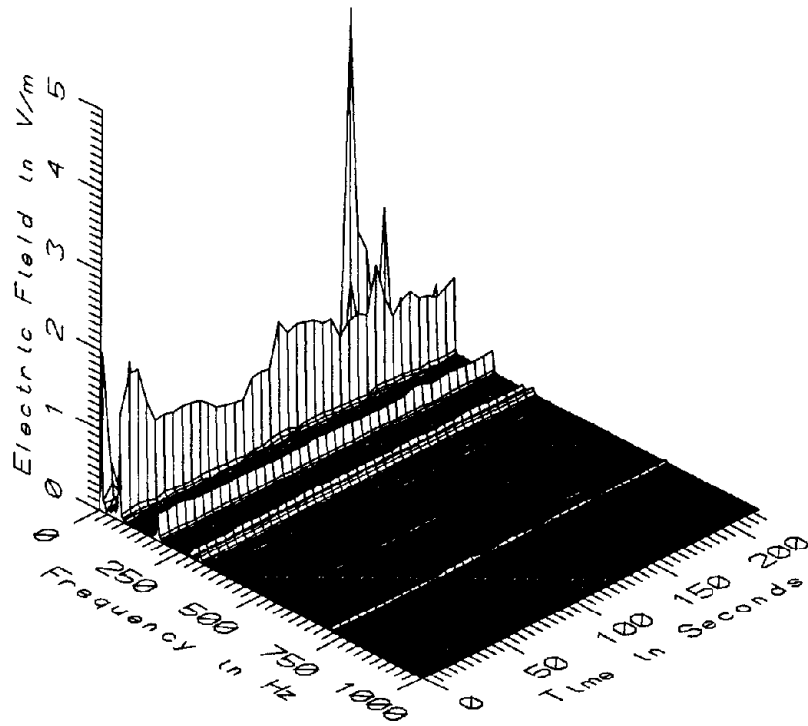

MET041 - ELECTRIC FIELD AT TRACTION POWER SUPPLY STATION



**APPENDIX AL**

**DATASET MET042**

**AT TRACTION POWER SUPPLY STATION SOUTH OF SHADY GROVE**

Measurement Setup Code:           Staff:     44   Reference:  -  
  Drawing:  A-6

Vehicle Status:                    NA

Measurement Date:                 May 20, 1992

Measurement Time:                 Start:     09:05:11  
  End:       09:08:36

Number of Samples:                 37

Programmed Sample Interval:       5 sec

Actual Sample Interval:            5.7 sec

**Frequency Spectrum Parameters**

<u>Probe Type:</u>	<u>Wideband</u>	<u>Static</u>
Maximum Frequency (Hz)	2560	100
Minimum Frequency (Hz)	5	0
Spectral Bandwidth (Hz)	5	1

Missing Data: No reference probe

Saturated Data: None

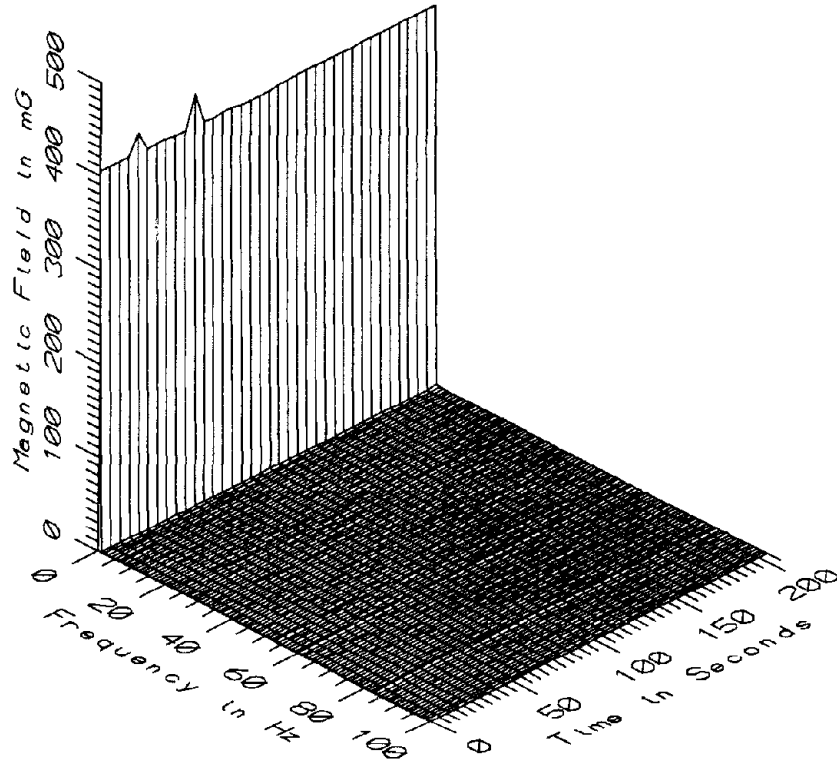

MET042 - 10cm FROM SOUTH WALL OF TRACTION POWER SUPPLY STATION

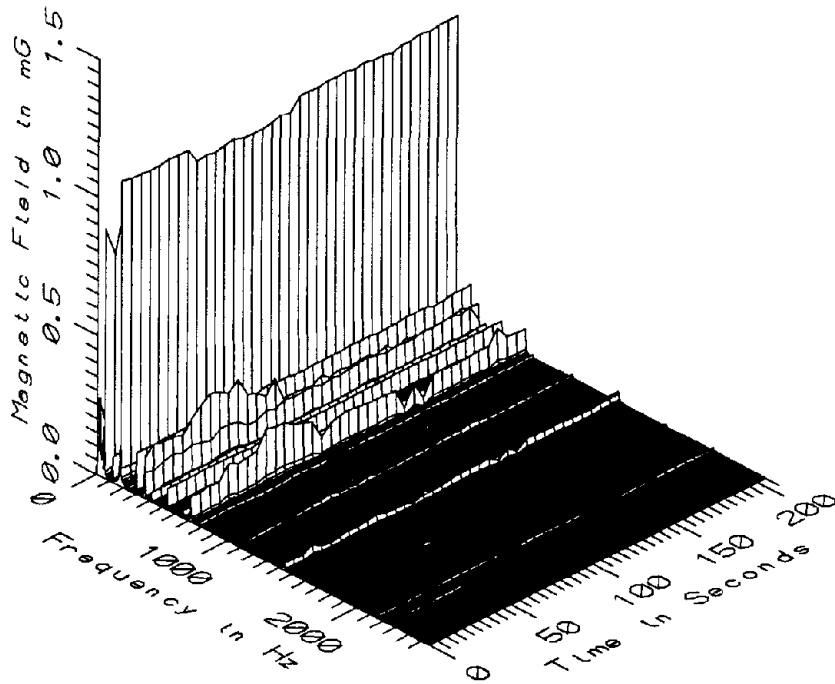

MET042 - 10cm FROM SOUTH WALL OF TRACTION POWER SUPPLY STATION

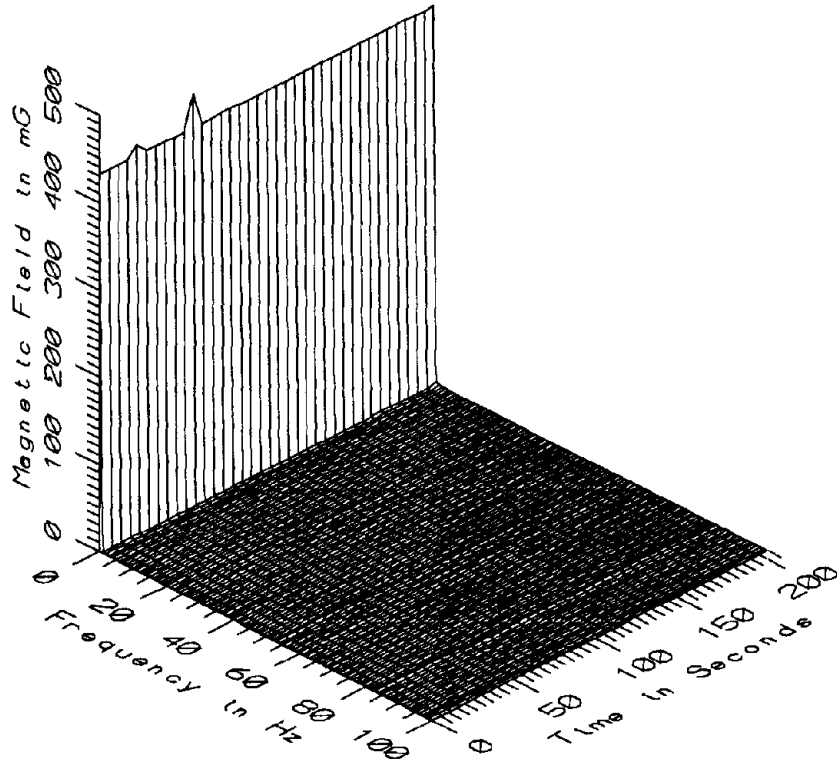

MET042 - 60cm FROM SOUTH WALL OF TRACTION POWER SUPPLY STATION

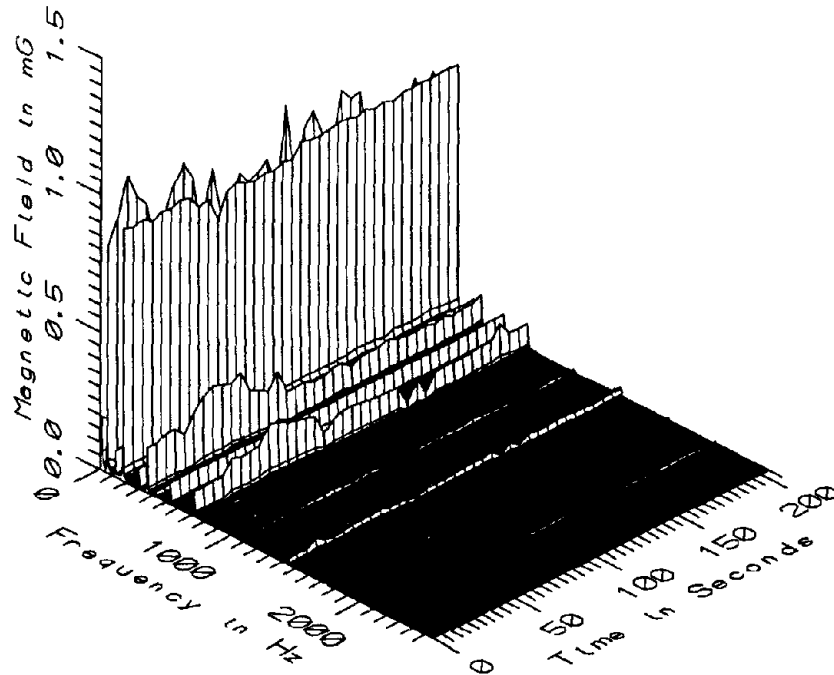

MET042 - 60cm FROM SOUTH WALL OF TRACTION POWER SUPPLY STATION

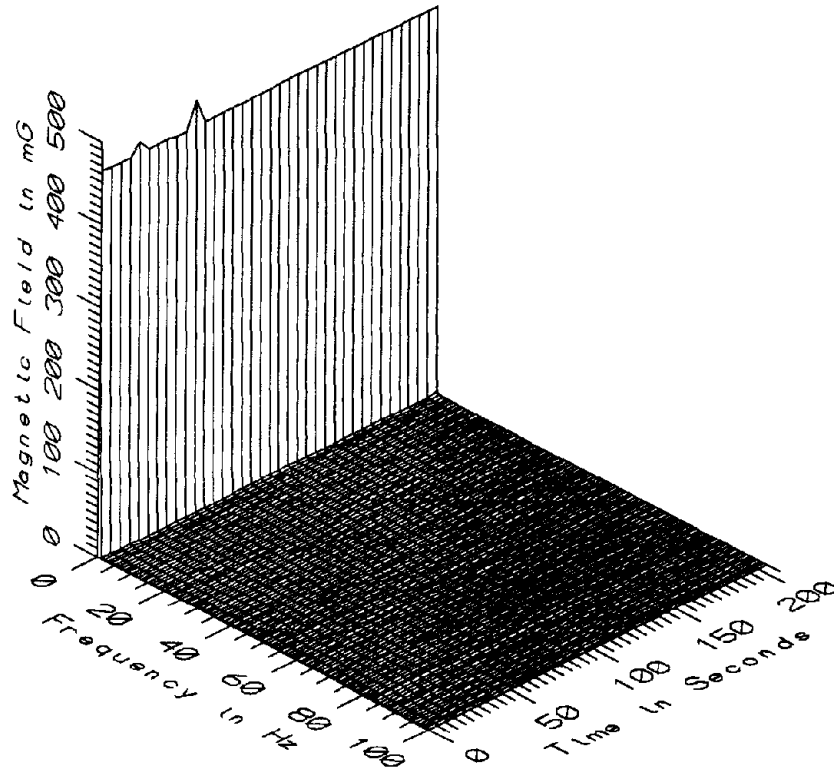

MET042 - 110cm FROM SOUTH WALL OF TRACTION POWER SUPPLY STATION

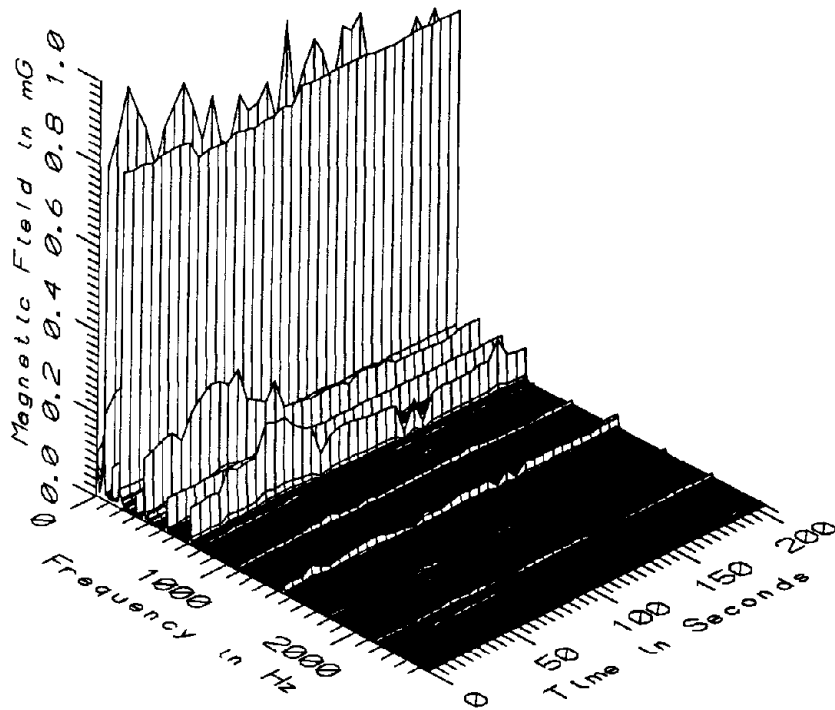

MET042 - 110cm FROM SOUTH WALL OF TRACTION POWER SUPPLY STATION

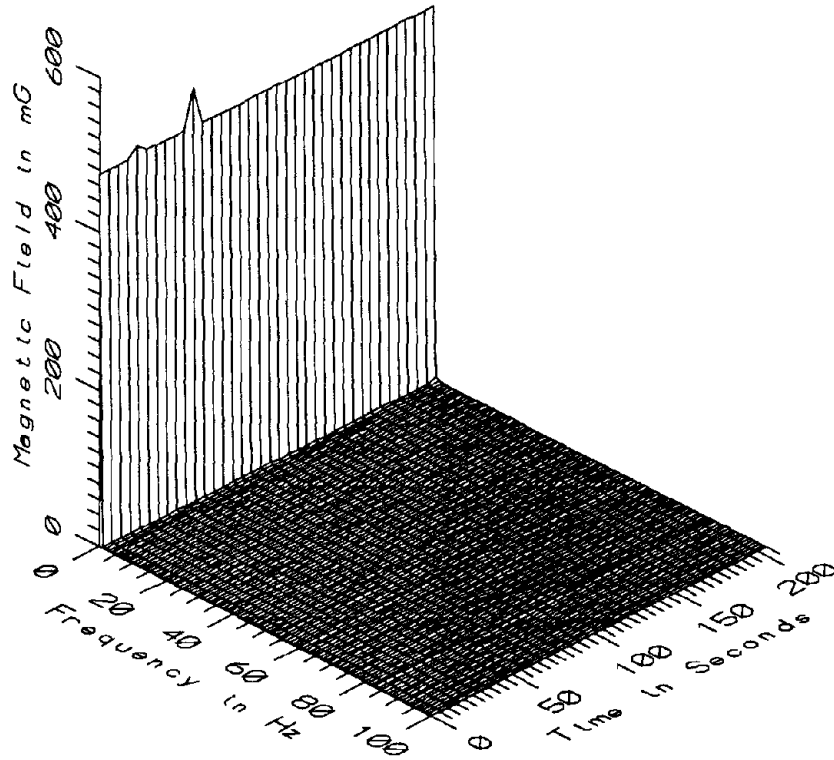

MET042 - 160cm FROM SOUTH WALL OF TRACTION POWER SUPPLY STATION

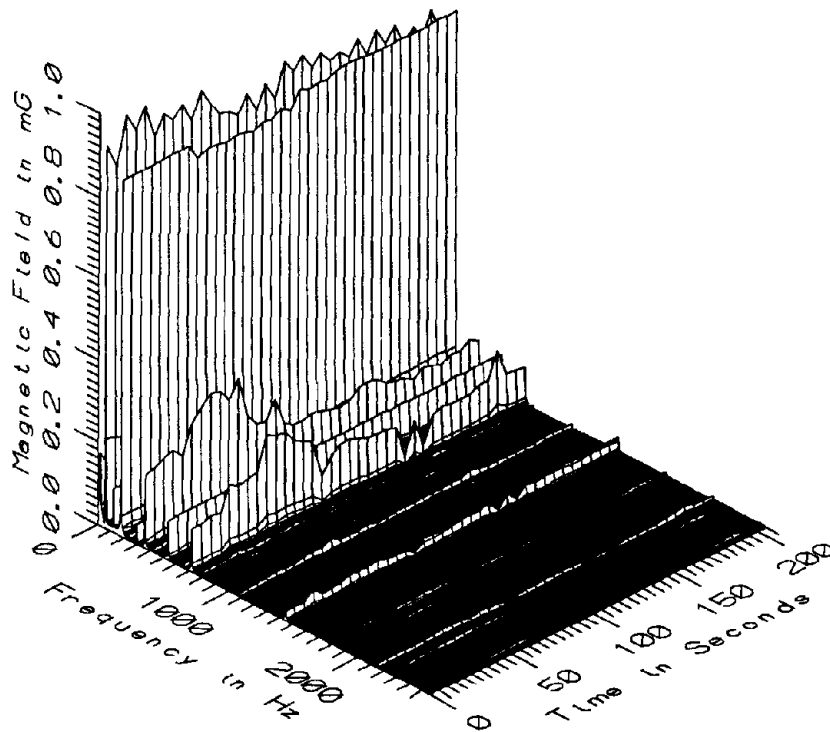

MET042 - 160cm FROM SOUTH WALL OF TRACTION POWER SUPPLY STATION

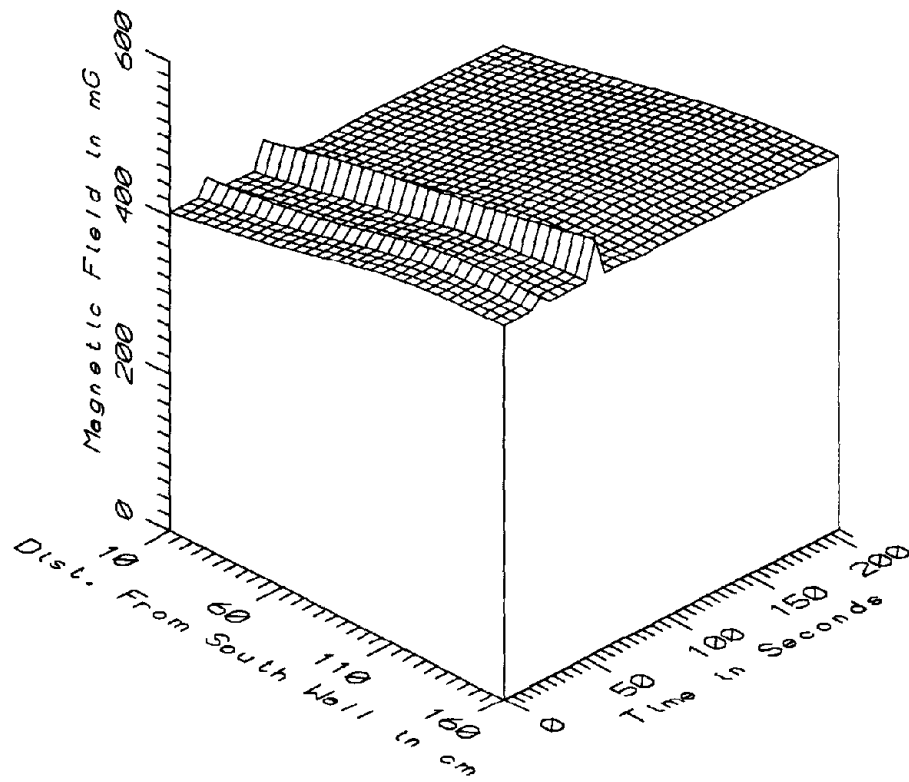

MET042 - TRACTION POWER SUPPLY STATION - STATIC

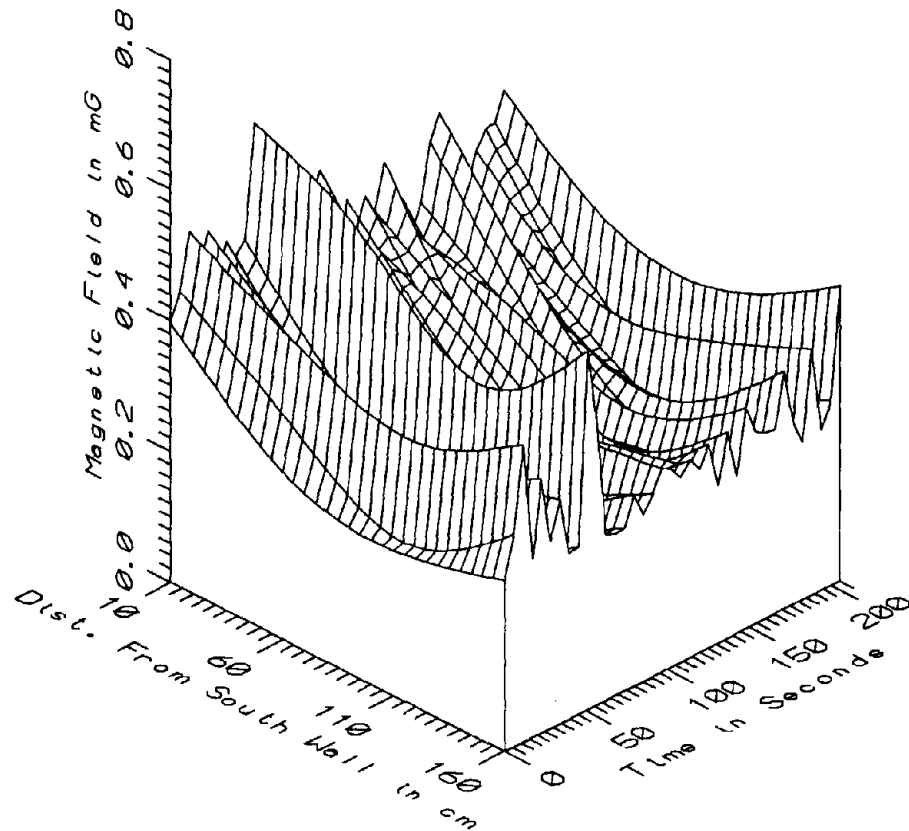

MET042 - TRACTION POWER SUPPLY STATION - LOW FREQ. 5-45Hz

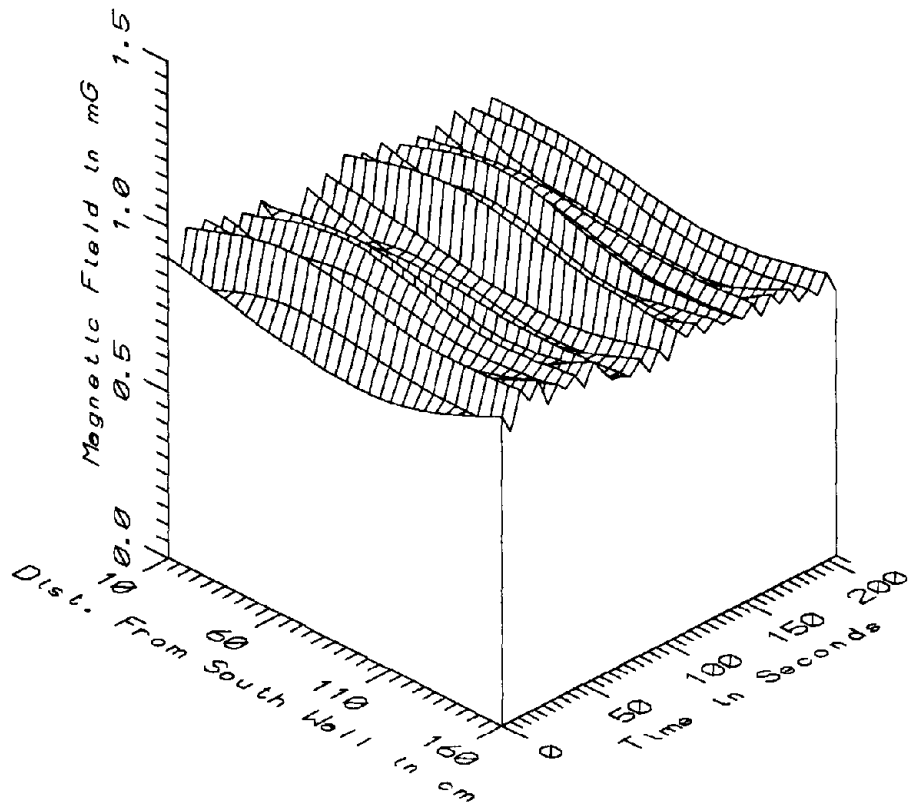

MET042 - TRACTION POWER SUPPLY STATION - POWER FREQ, 50-60Hz

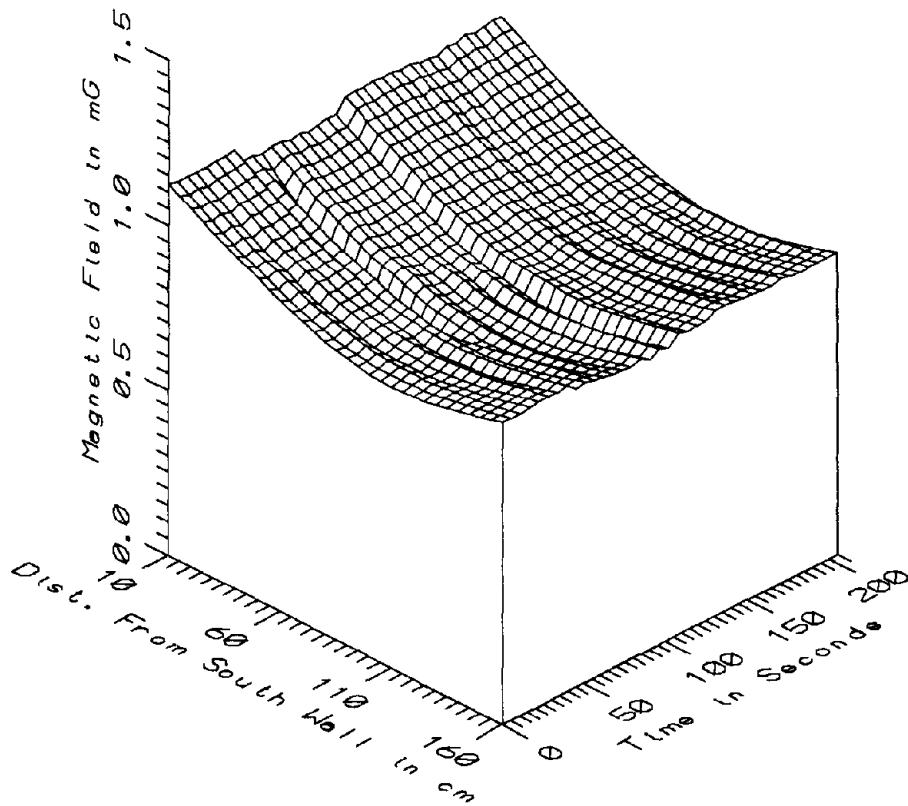

MET042 - TRACTION POWER SUPPLY STATION - POWER HARM, 65-300Hz

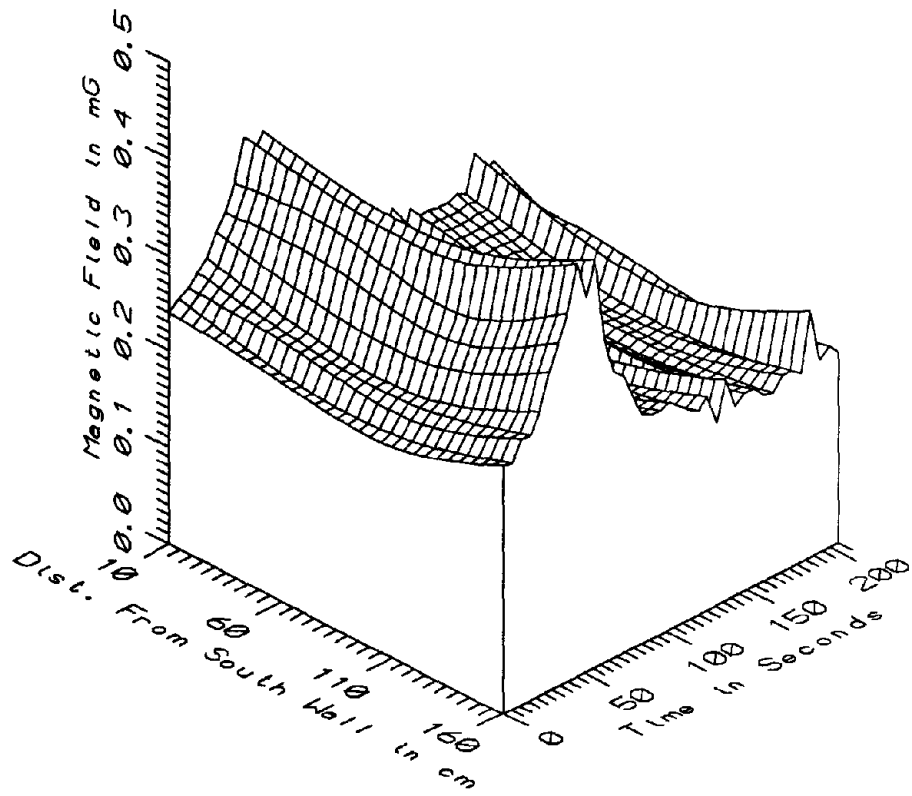

MET042 - TRACTION POWER SUPPLY STATION - HIGH FREQ, 305-2560Hz

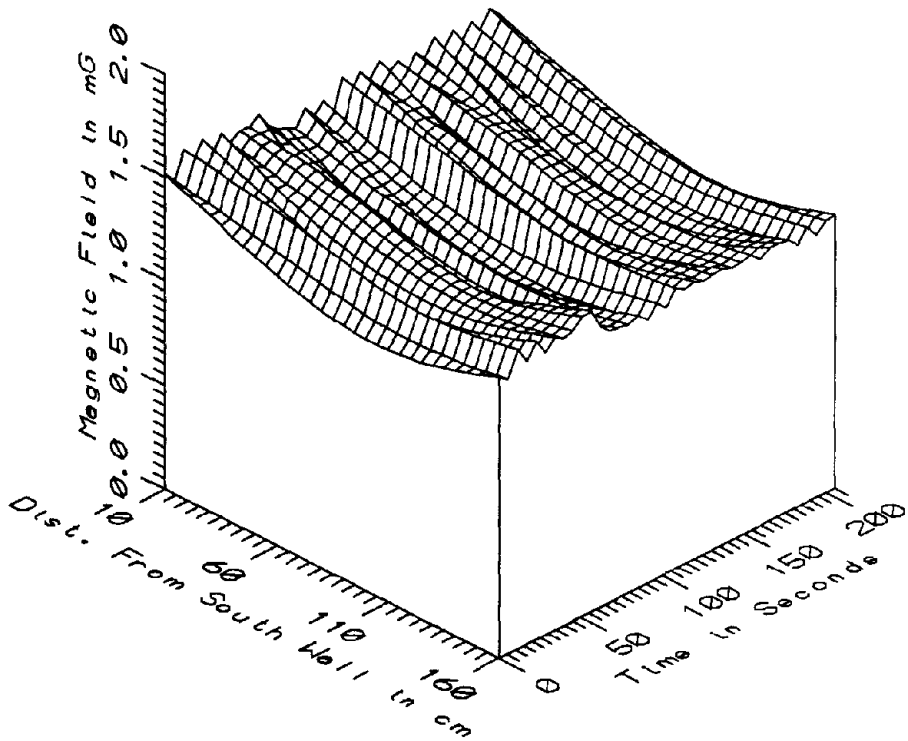

MET042 - TRACTION POWER SUPPLY STATION - ALL FREQ, 5-2560Hz



MET042 - T.P.S.S. SOUTH OF SHADY GROVE, FROM SOUTH WALL TOTAL OF 37 SAMPLES						
FREQUENCY BAND	DIST FROM WALL (cm)	MINIMUM MAGNETIC FIELD (mG)	MAXIMUM MAGNETIC FIELD (mG)	AVERAGE MAGNETIC FIELD (mG)	STANDARD DEVIATION (mG)	COEFFICIENT OF VARIATION (%)
STATIC	10	401.87	437.92	405.68	6.59	1.62
	60	431.43	470.47	433.85	6.55	1.51
	110	462.77	495.08	465.47	5.56	1.19
	160	474.40	525.21	477.65	8.25	1.73
5-45Hz LOW FREQ	10	0.33	0.64	0.44	0.06	13.89
	60	0.21	0.54	0.29	0.06	22.36
	110	0.16	0.41	0.23	0.06	27.30
	160	0.24	0.55	0.31	0.07	22.72
50-60Hz PWR FREQ	10	0.76	0.97	0.86	0.06	7.41
	60	0.70	1.05	0.85	0.09	11.03
	110	0.69	0.98	0.81	0.07	8.92
	160	0.80	0.98	0.89	0.04	4.99
65-300Hz PWR HARM	10	1.07	1.13	1.10	0.02	1.74
	60	0.82	0.94	0.91	0.02	2.56
	110	0.81	0.87	0.85	0.02	2.17
	160	0.88	0.92	0.91	0.01	1.42
305-2560Hz HIGH FREQ	10	0.19	0.38	0.25	0.05	20.30
	60	0.16	0.37	0.23	0.06	25.39
	110	0.15	0.37	0.22	0.06	26.42
	160	0.19	0.43	0.26	0.07	26.42
5-2560Hz ALL FREQ	10	1.39	1.59	1.49	0.05	3.30
	60	1.19	1.49	1.31	0.07	5.66
	110	1.13	1.38	1.22	0.06	5.06
	160	1.26	1.44	1.33	0.05	3.70

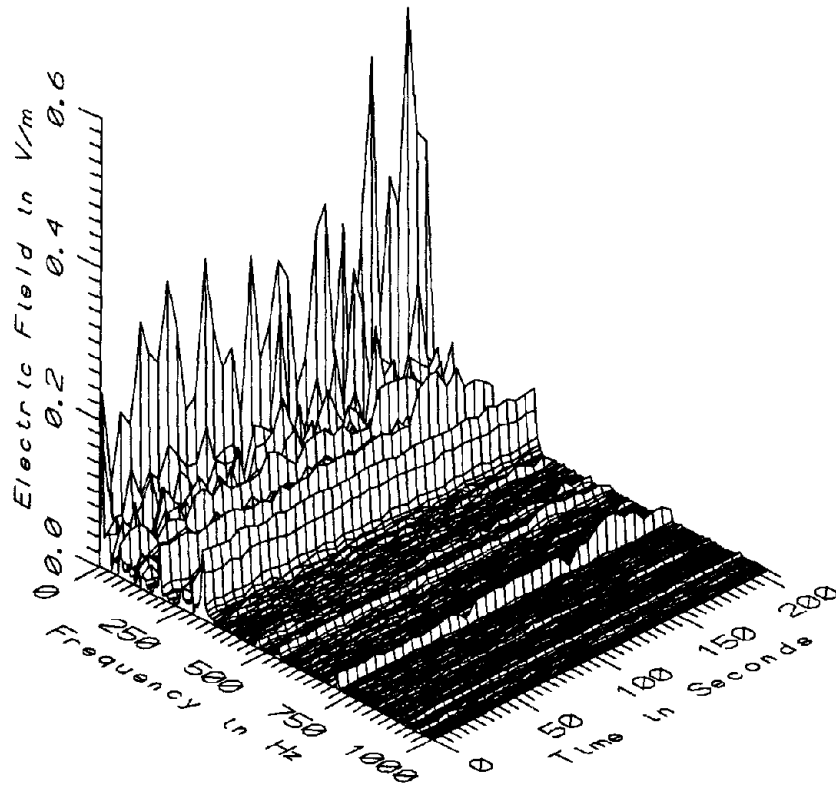

MET042 - ELECTRIC FIELD AT TRACTION POWER SUPPLY STATION

APPENDIX AM

DATASET MET043  
AT SHADY GROVE TRACTION POWER SUPPLY STATION

Measurement Setup Code:        Staff:    46    Reference: -  
   Drawing: A-7

Vehicle Status:                    NA

Measurement Date:                May 20, 1992

Measurement Time:                Start:    09:41:33  
   End:      09:44:53

Number of Samples:                38

Programmed Sample Interval:    5 sec

Actual Sample Interval:         5.4 sec

Frequency Spectrum Parameters

<u>Probe Type:</u>	<u>Wideband</u>	<u>Static</u>
Maximum Frequency (Hz)	2560	100
Minimum Frequency (Hz)	5	0
Spectral Bandwidth (Hz)	5	1

Missing Data: No reference probe

Saturated Data: None

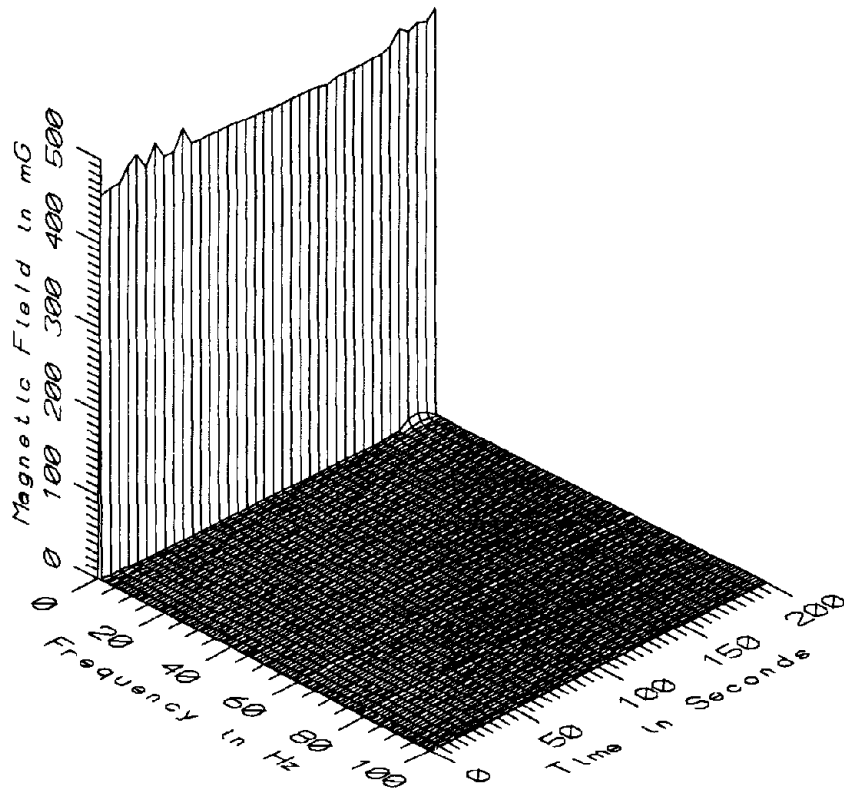

MET043 - 10cm FROM SOUTH FENCE OF TRACTION POWER SUPPLY STATION

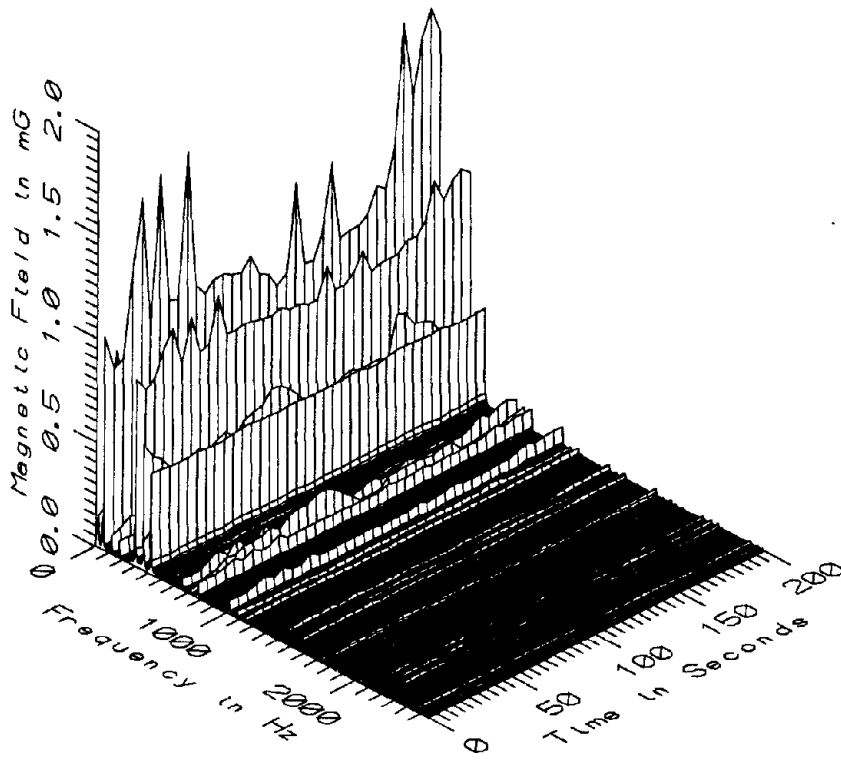

MET043 - 10cm FROM SOUTH FENCE OF TRACTION POWER SUPPLY STATION

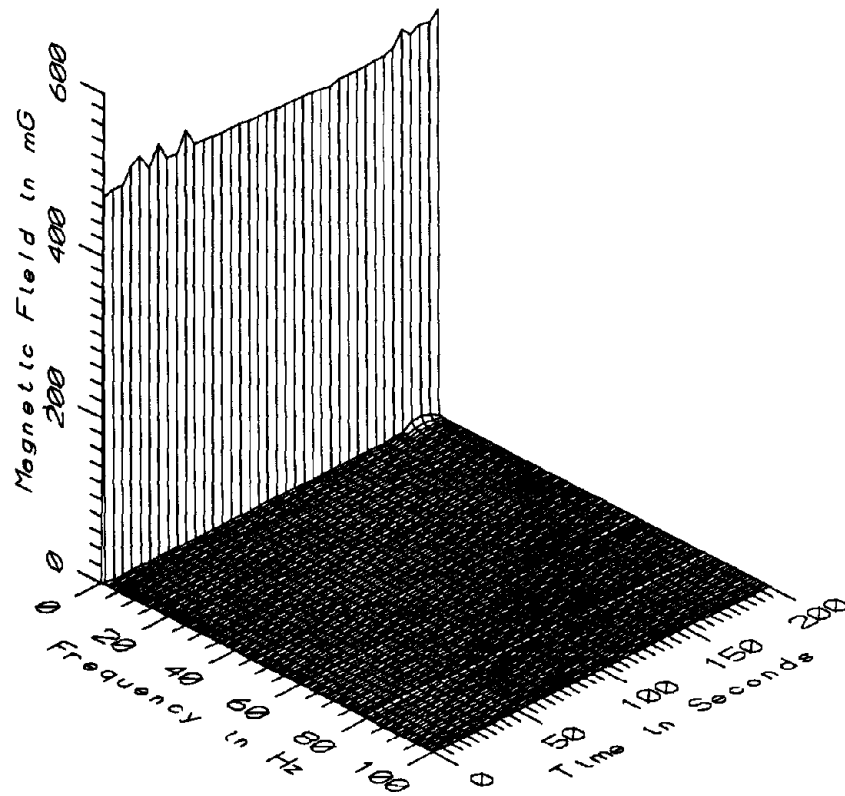

MET043 - 60cm FROM SOUTH FENCE OF TRACTION POWER SUPPLY STATION

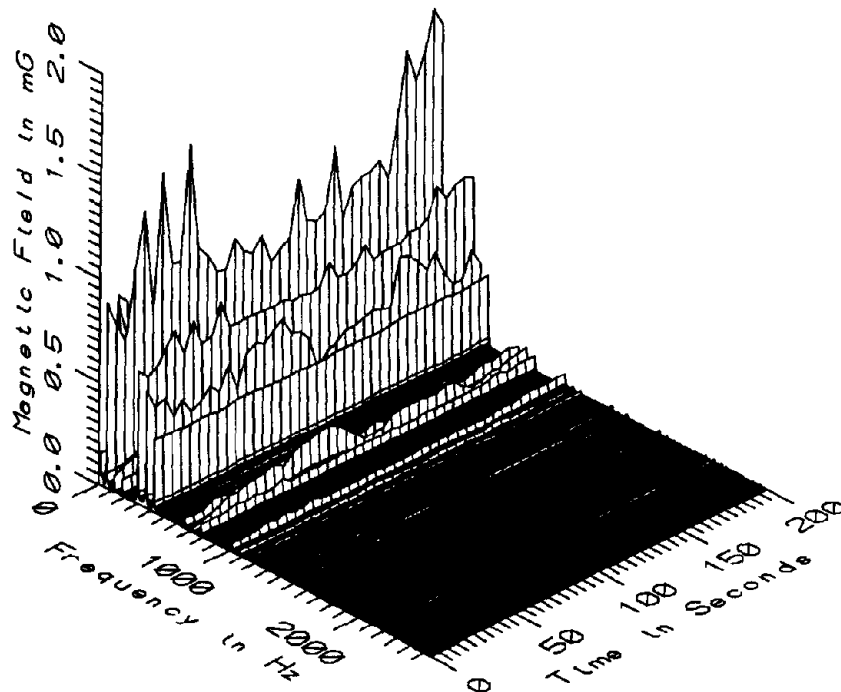

MET043 - 60cm FROM SOUTH FENCE OF TRACTION POWER SUPPLY STATION

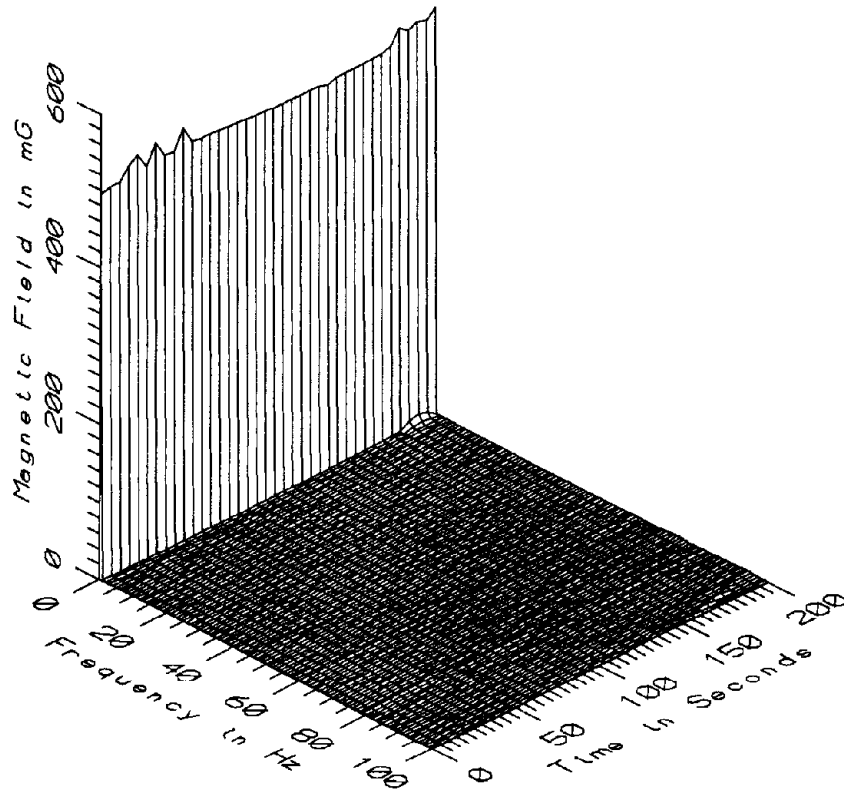

MET043 - 110cm FROM SOUTH FENCE OF TRACTION POWER SUPPLY STATION

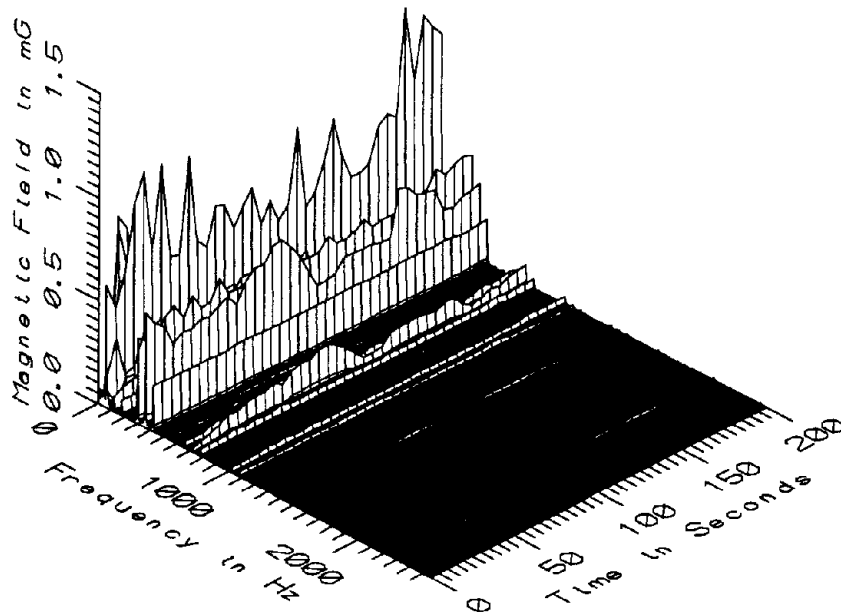

MET043 - 110cm FROM SOUTH FENCE OF TRACTION POWER SUPPLY STATION

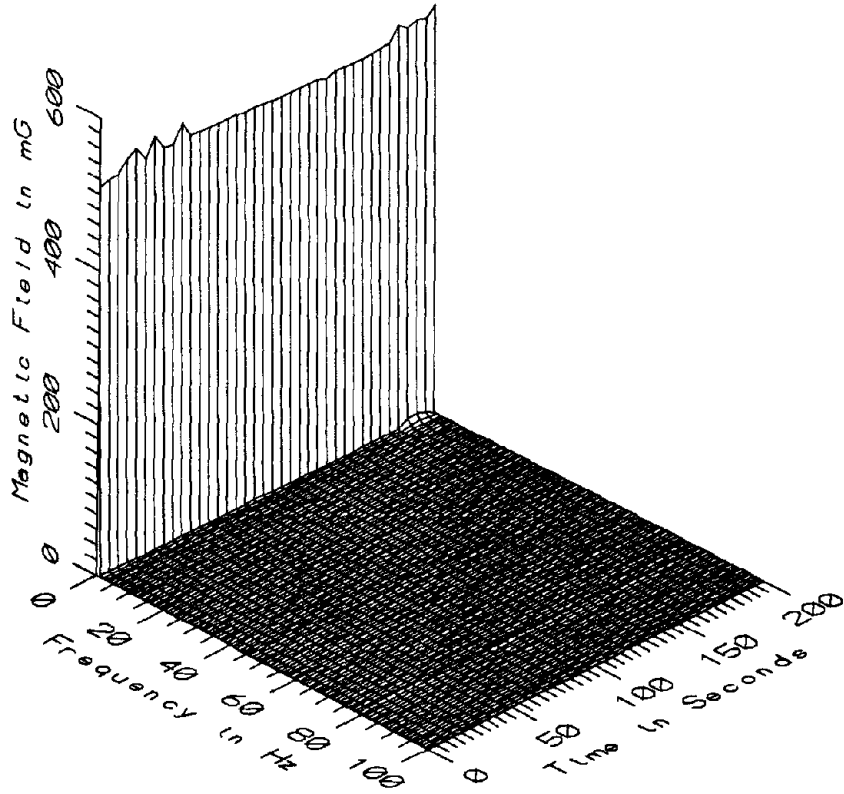

MET043 - 160cm FROM SOUTH FENCE OF TRACTION POWER SUPPLY STATION

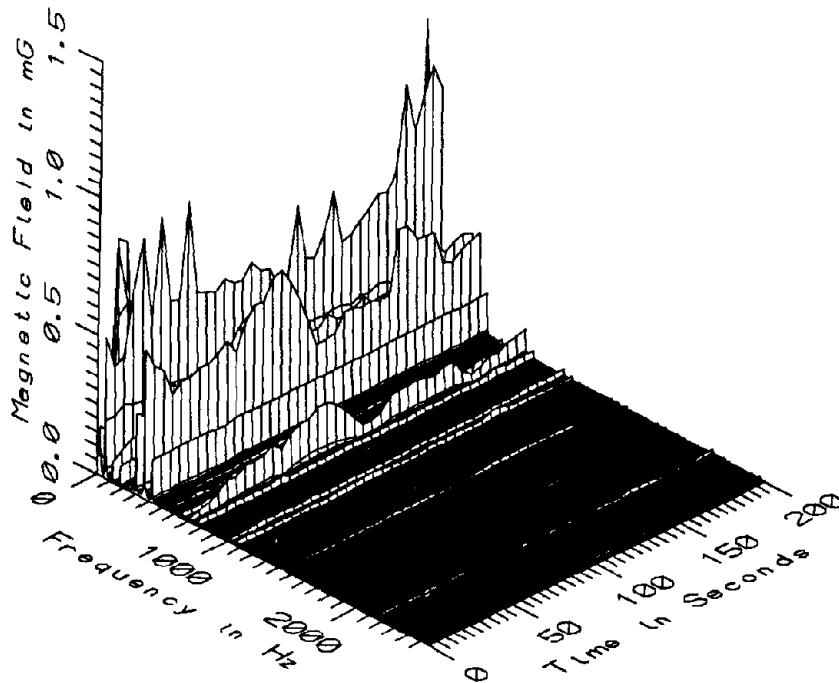

MET043 - 160cm FROM SOUTH FENCE OF TRACTION POWER SUPPLY STATION

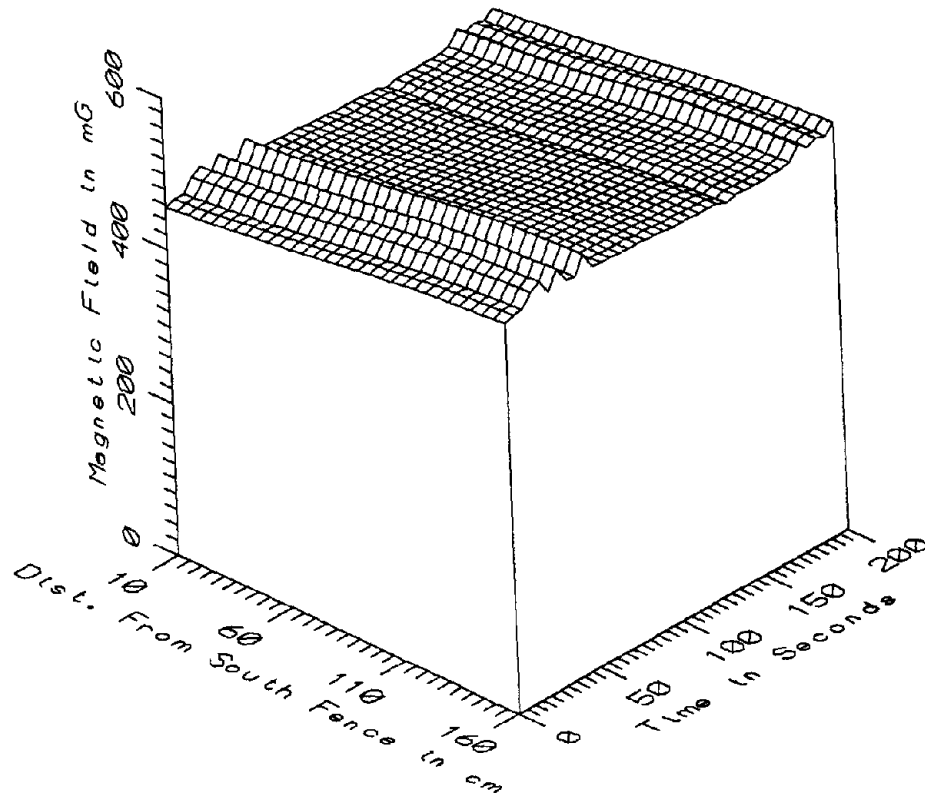

MET043 - TRACTION POWER SUPPLY STATION - STATIC

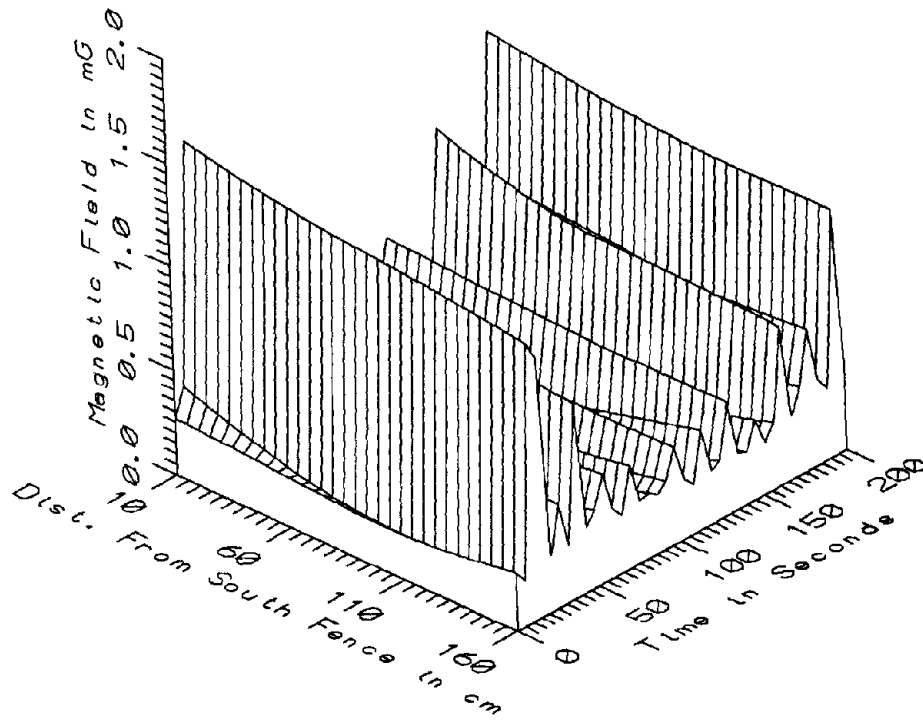

MET043 - TRACTION POWER SUPPLY STATION - LOW FREQ, 5-45Hz



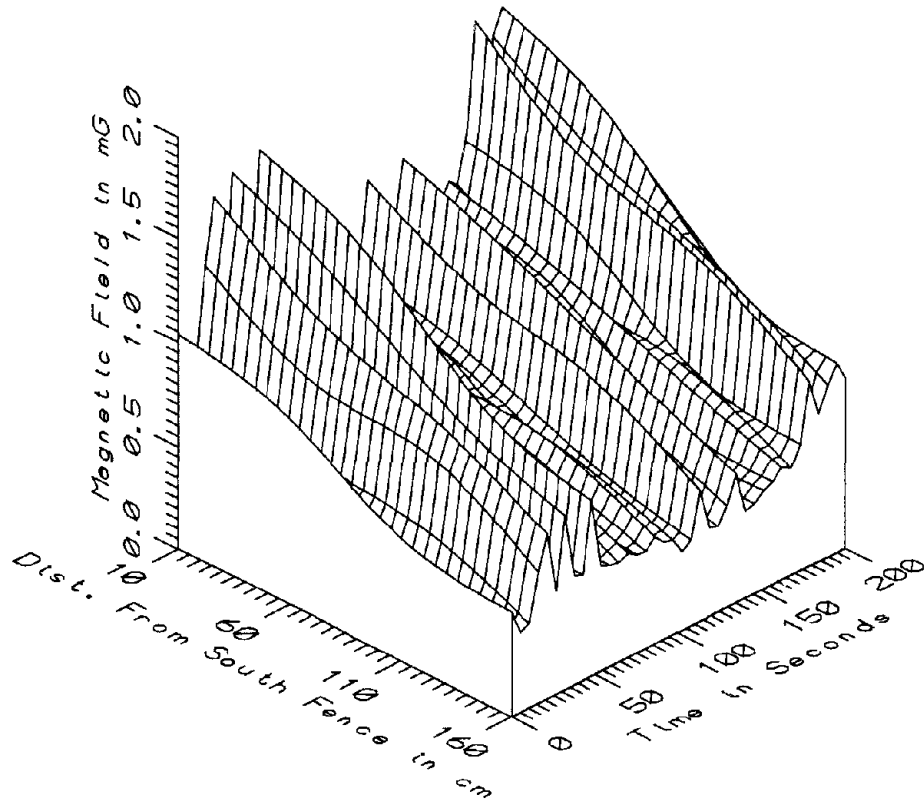

MET043 - TRACTION POWER SUPPLY STATION - POWER FREQ, 50-60Hz

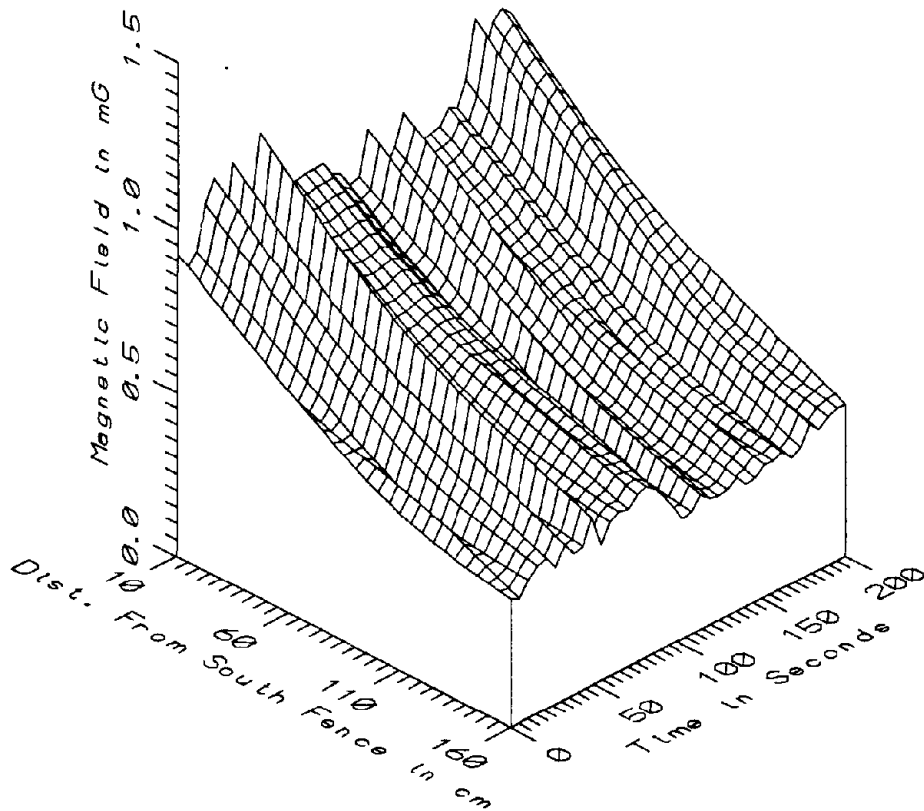

MET043 - TRACTION POWER SUPPLY STATION - POWER HARM, 65-300Hz

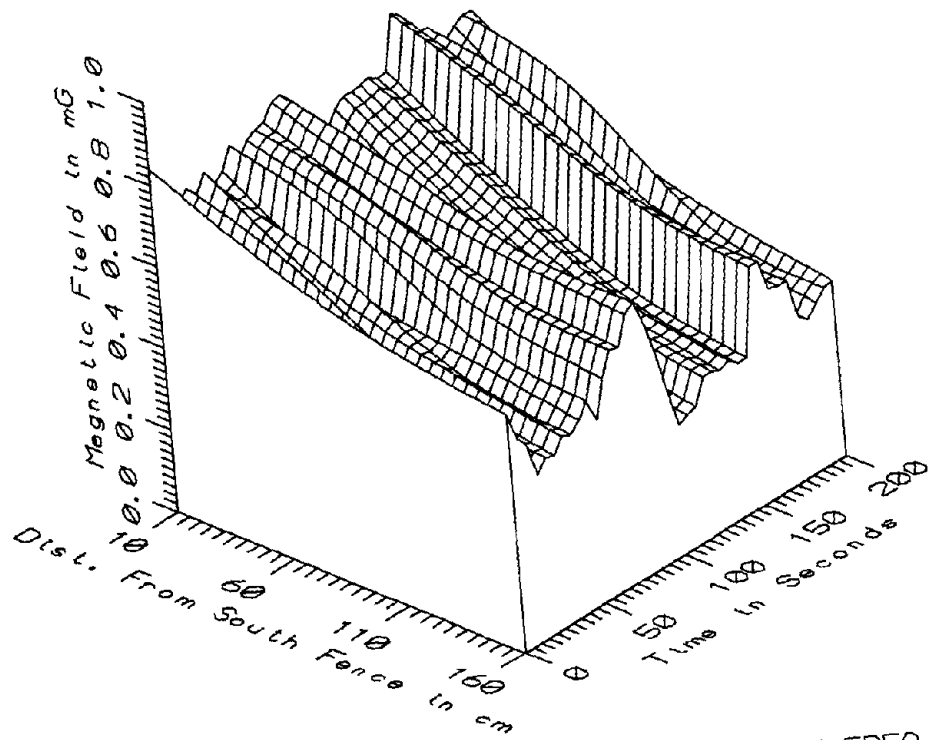

MET043 - TRACTION POWER SUPPLY STATION - HIGH FREQ, 305-2560Hz

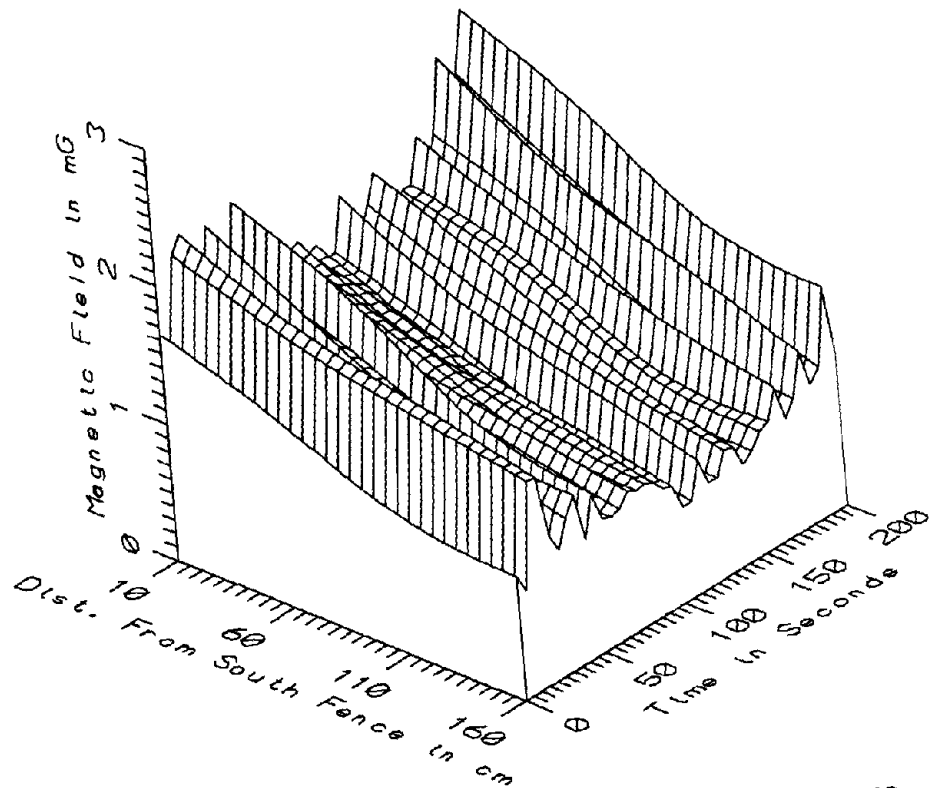

MET043 - TRACTION POWER SUPPLY STATION - ALL FREQ, 5-2560Hz

MET043 - SHADY GROVE T.P.S.S, FROM SOUTH EDGE OF FENCE TOTAL OF 38 SAMPLES						
FREQUENCY BAND	DIST FROM FENCE (cm)	MINIMUM MAGNETIC FIELD (mG)	MAXIMUM MAGNETIC FIELD (mG)	AVERAGE MAGNETIC FIELD (mG)	STANDARD DEVIATION (mG)	COEFFICIENT OF VARIATION (%)
STATIC	10	454.21	488.25	465.31	8.95	1.92
	60	469.67	505.41	481.33	9.44	1.96
	110	492.07	529.30	504.21	9.59	1.90
	160	505.80	540.88	517.57	9.15	1.77
5-45HZ	10	0.27	1.56	0.51	0.32	62.62
LOW FREQ	60	0.20	1.45	0.43	0.32	74.00
	110	0.10	1.40	0.38	0.33	86.76
	160	0.22	1.33	0.45	0.28	62.57
50-60HZ	10	0.87	1.83	1.18	0.30	25.47
PWR FREQ	60	0.69	1.55	0.98	0.24	24.93
	110	0.48	1.22	0.74	0.20	27.38
	160	0.39	0.92	0.57	0.16	27.51
65-300HZ	10	0.85	1.18	0.97	0.09	9.63
PWR HARM	60	0.63	0.86	0.73	0.07	8.99
	110	0.45	0.65	0.54	0.05	10.12
	160	0.36	0.52	0.43	0.04	10.04
305-2560HZ	10	0.67	0.85	0.75	0.04	5.74
HIGH FREQ	60	0.47	0.76	0.62	0.07	11.55
	110	0.37	0.68	0.51	0.08	16.03
	160	0.31	0.66	0.46	0.09	19.85
5-2560HZ	10	1.44	2.63	1.81	0.30	16.61
ALL FREQ	60	1.11	2.25	1.47	0.26	17.76
	110	0.82	1.75	1.15	0.24	20.90
	160	0.68	1.62	0.99	0.22	22.14

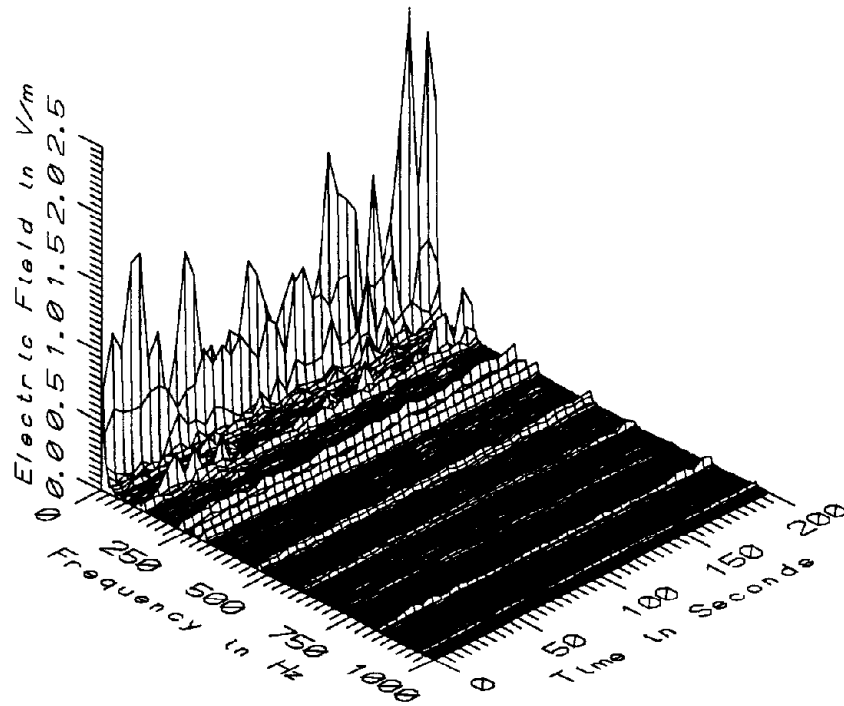

MET043 - ELECTRIC FIELD AT TRACTION POWER SUPPLY STATION

**APPENDIX AN**  
**DATASET MET044**  
**AT SHADY GROVE TRACTION POWER SUPPLY STATION**

Measurement Setup Code:           Staff:     48   Reference:  -  
  Drawing:  A-7

Vehicle Status:                    NA

Measurement Date:                 May 20, 1992

Measurement Time:                 Start:     09:52:56  
  End:       09:56:56

Number of Samples:                38

Programmed Sample Interval:      5 sec

Actual Sample Interval:          6.5 sec

**Frequency Spectrum Parameters**

<u>Probe Type:</u>	<u>Wideband</u>	<u>Static</u>
Maximum Frequency (Hz)	2560	100
Minimum Frequency (Hz)	5	0
Spectral Bandwidth (Hz)	5	1

Missing Data:  No reference probe

Saturated Data:  None

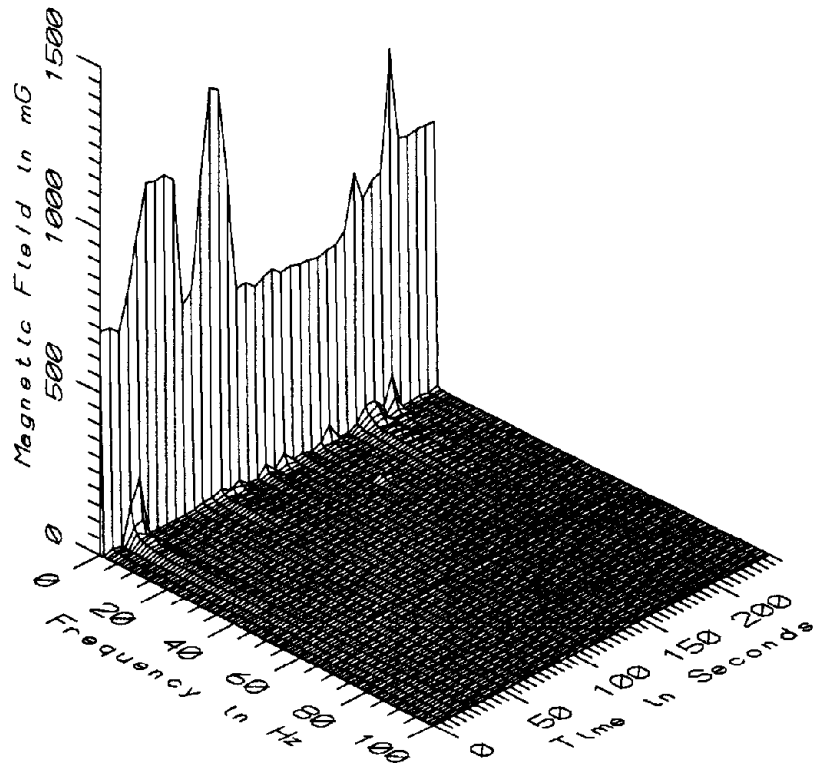

MET044 - 10cm FROM SOUTH WALL OF TRACTION POWER SUPPLY STATION

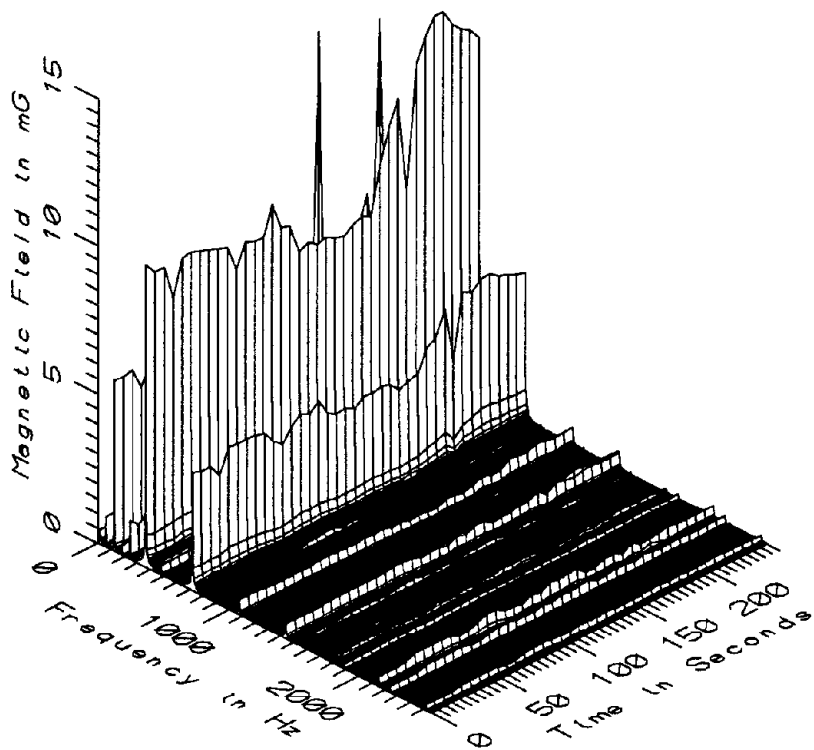

MET044 - 10cm FROM SOUTH WALL OF TRACTION POWER SUPPLY STATION

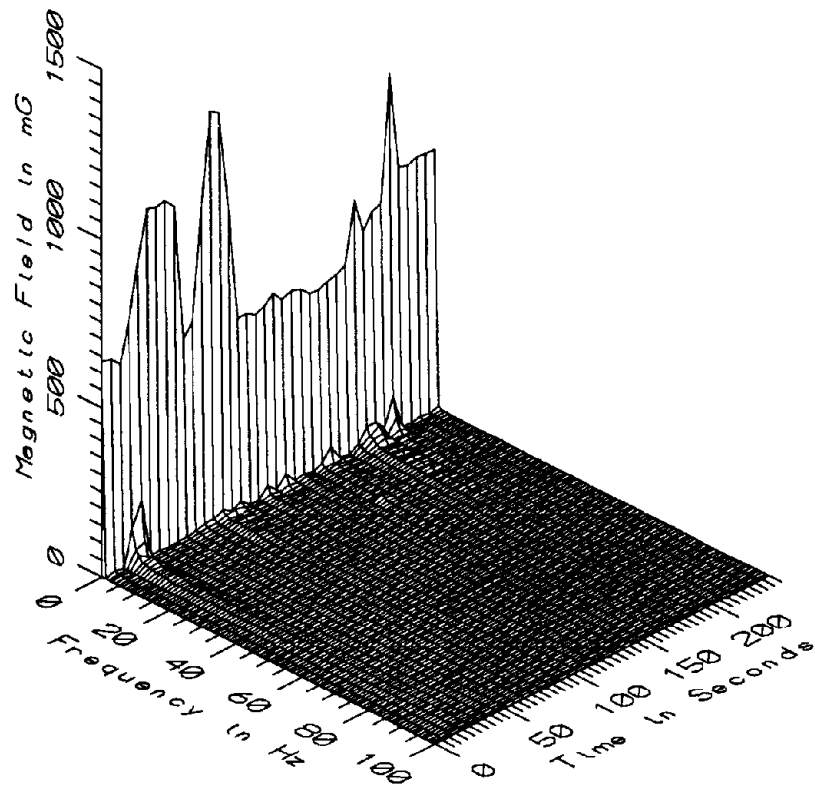

MET044 - 60cm FROM SOUTH WALL OF TRACTION POWER SUPPLY STATION

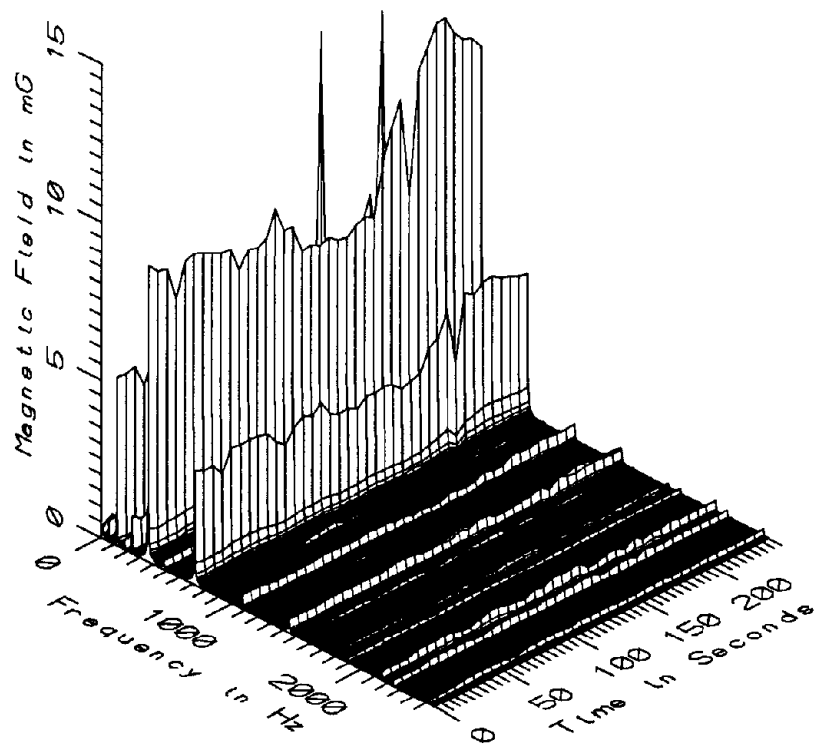

MET044 - 60cm FROM SOUTH WALL OF TRACTION POWER SUPPLY STATION

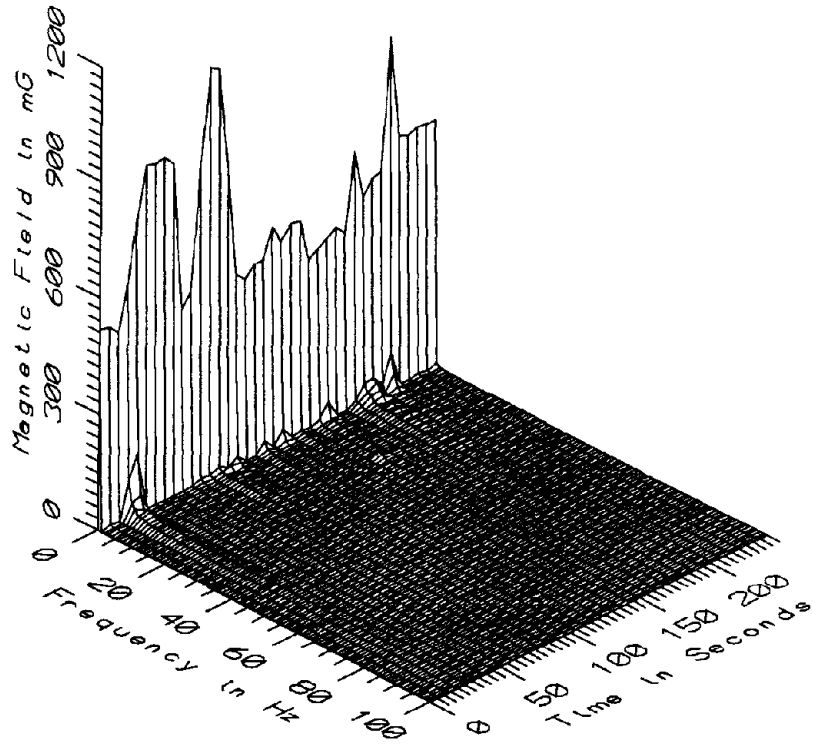

MET044 - 110cm FROM SOUTH WALL OF TRACTION POWER SUPPLY STATION

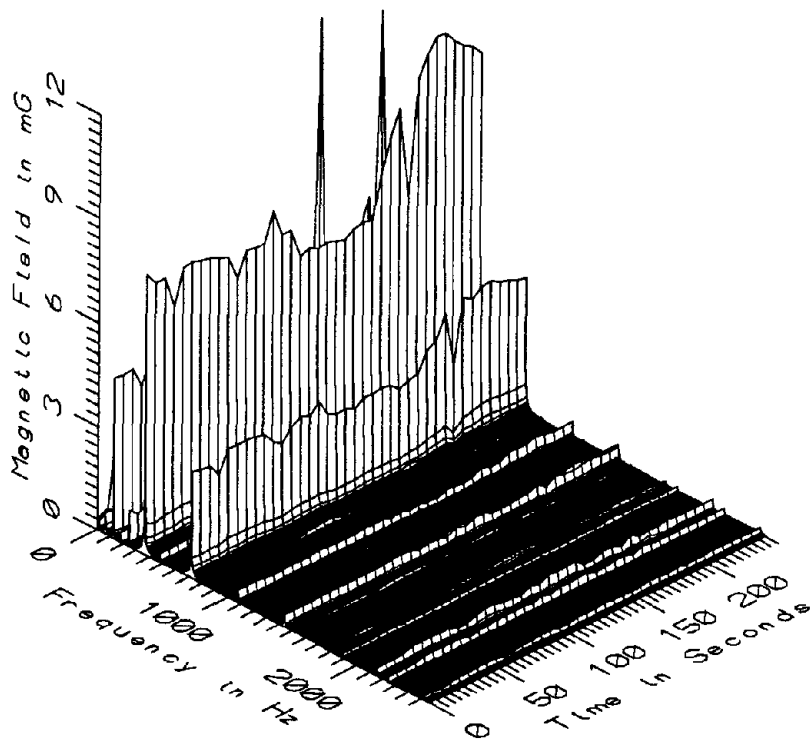

MET044 - 110cm FROM SOUTH WALL OF TRACTION POWER SUPPLY STATION



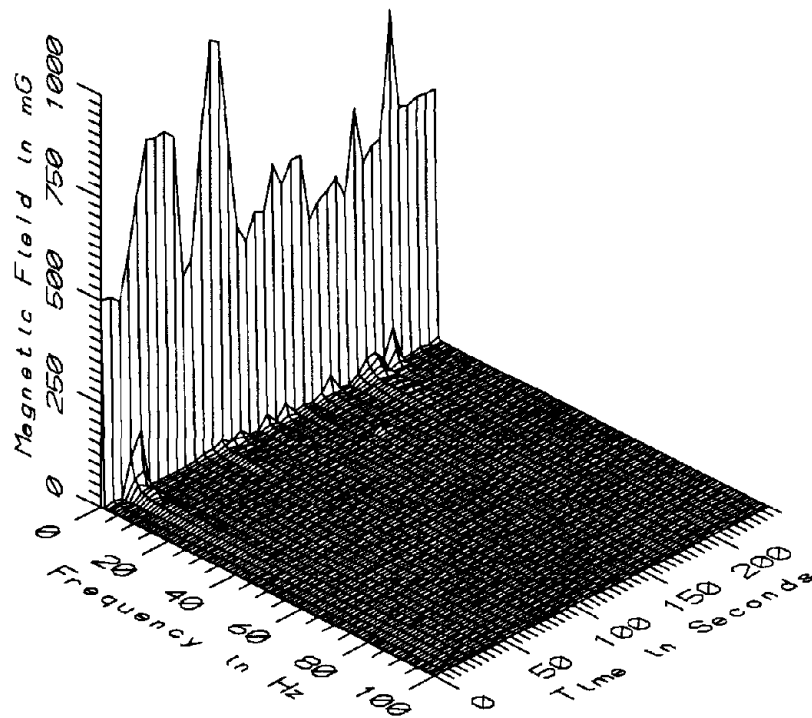

MET044 - 160cm FROM SOUTH WALL OF TRACTION POWER SUPPLY STATION

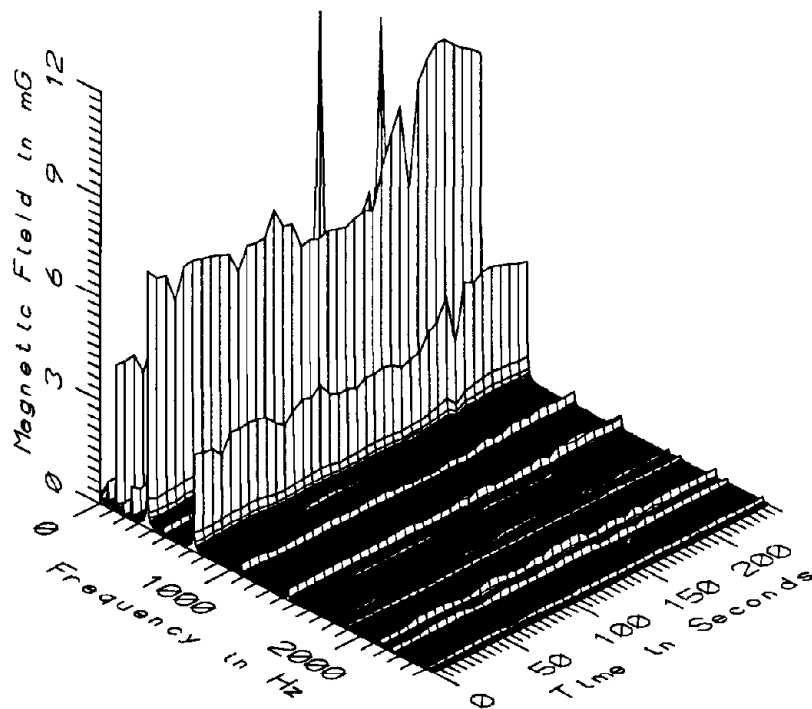

MET044 - 160cm FROM SOUTH WALL OF TRACTION POWER SUPPLY STATION

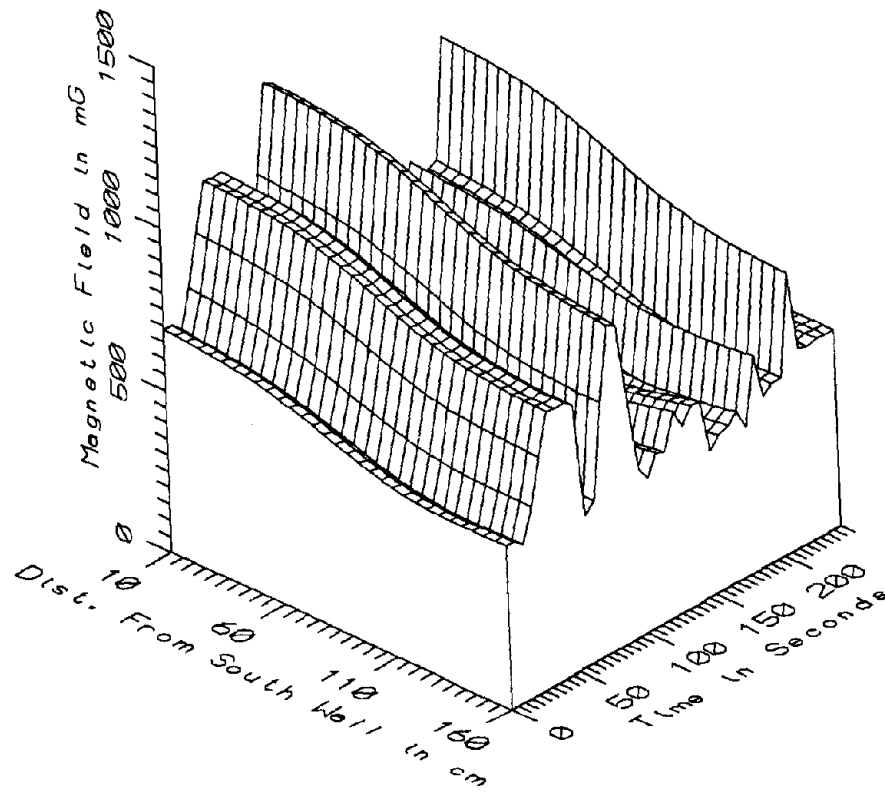

MET044 - TRACTION POWER SUPPLY STATION - STATIC

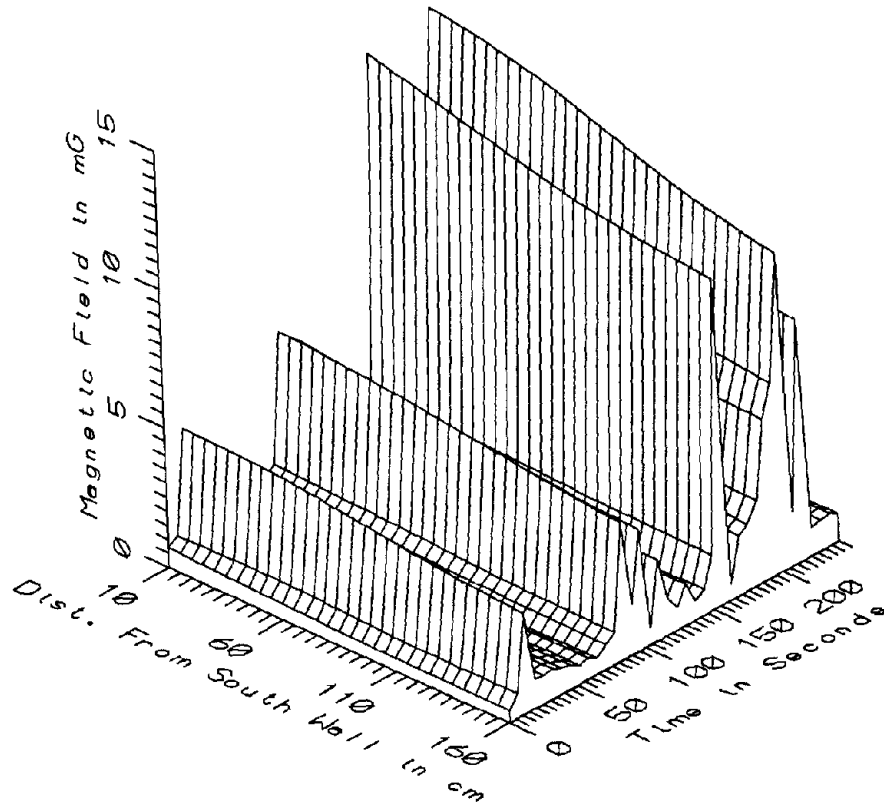

MET044 - TRACTION POWER SUPPLY STATION - LOW FREQ, 5-45Hz

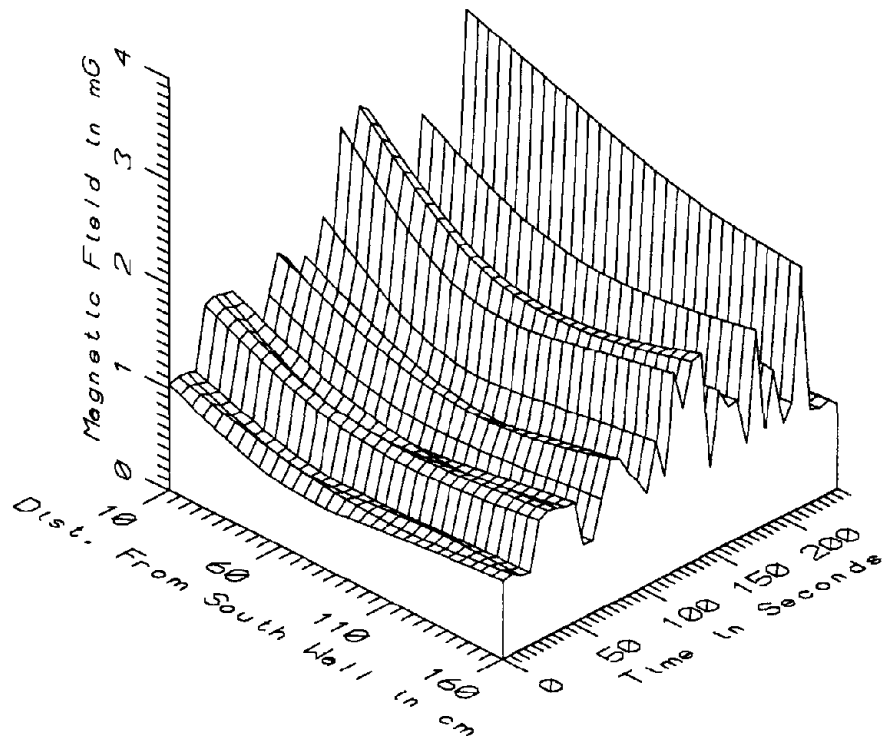

MET044 - TRACTION POWER SUPPLY STATION - POWER FREQ, 50-60Hz

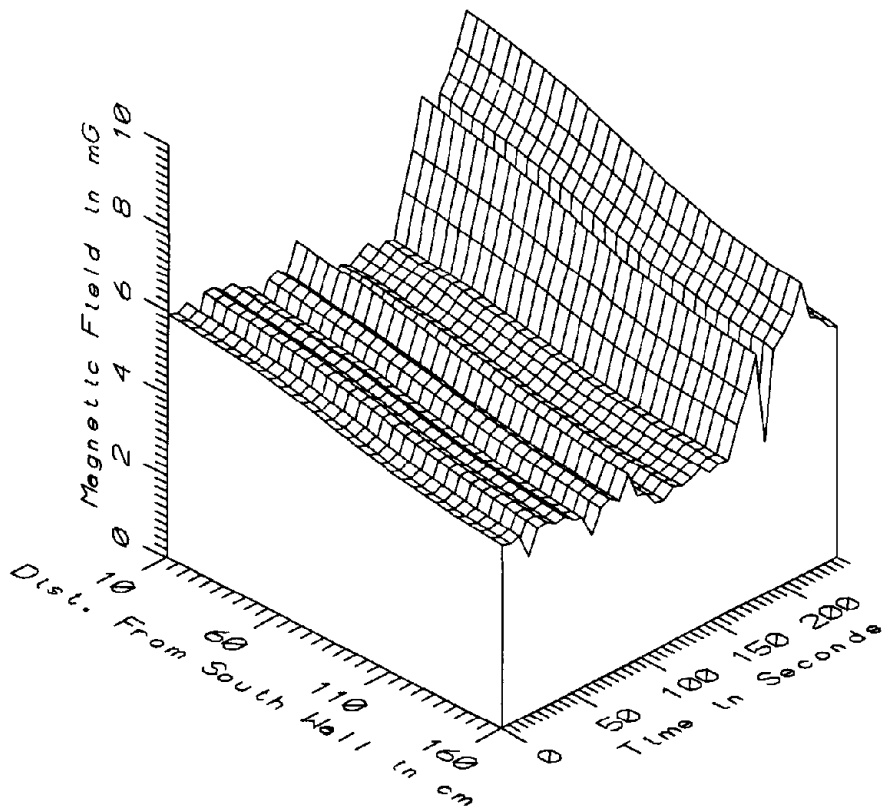

MET044 - TRACTION POWER SUPPLY STATION - POWER HARM, 65-300Hz

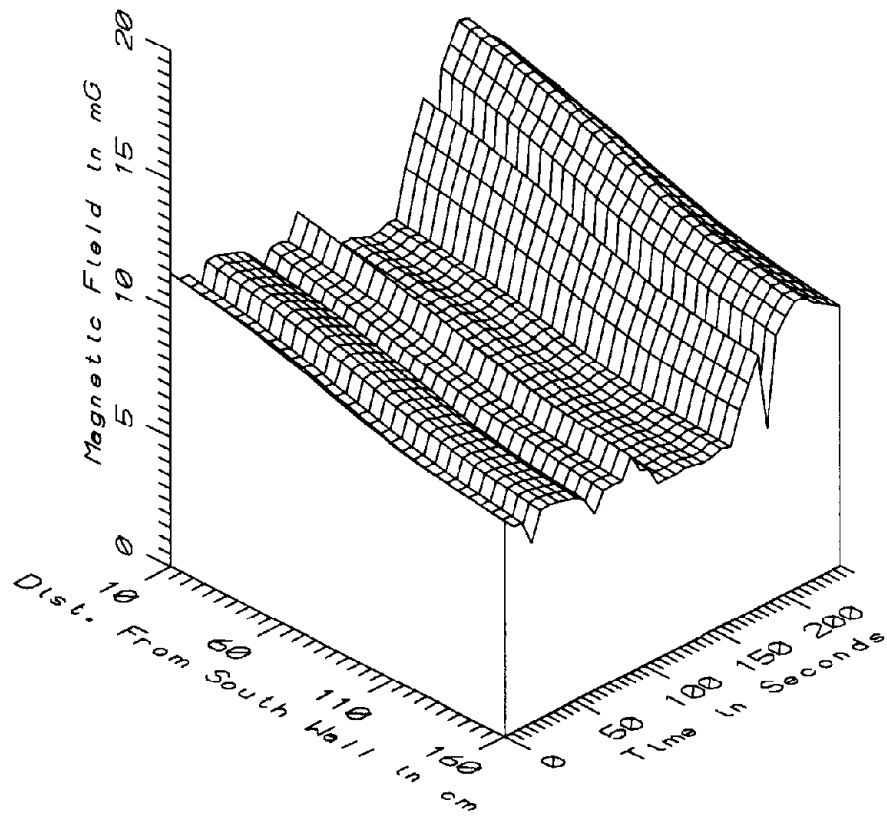

MET044 - TRACTION POWER SUPPLY STATION - HIGH FREQ, 305-2560Hz

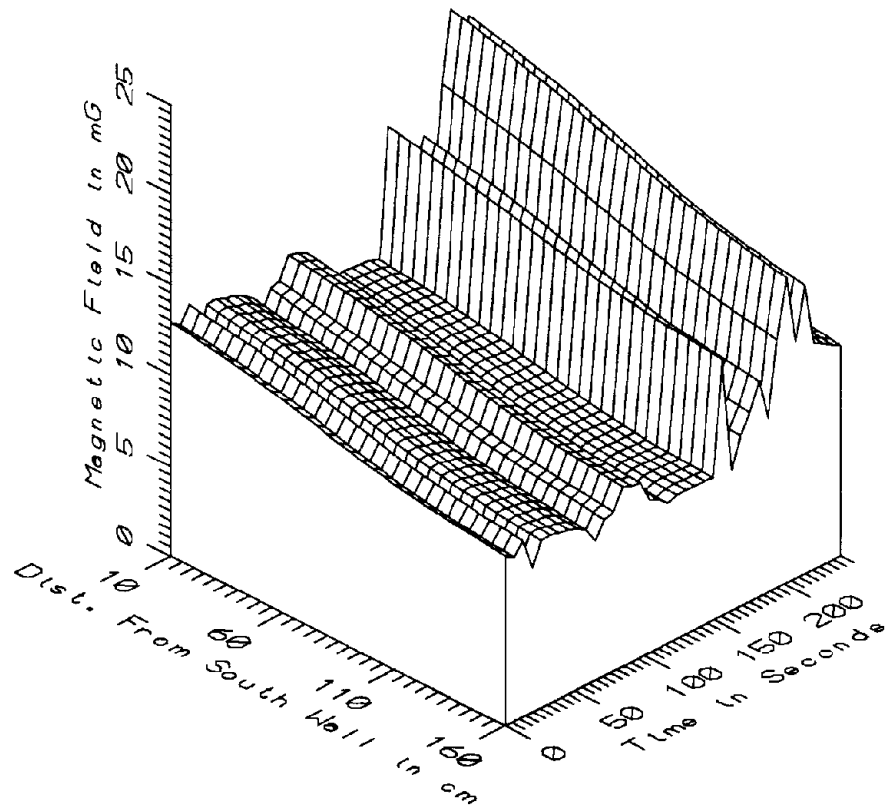

MET044 - TRACTION POWER SUPPLY STATION - ALL FREQ, 5-2560Hz

MET044 - SHADY GROVE T.P.S.S. FROM SOUTH WALL		TOTAL OF 38 SAMPLES				
FREQUENCY BAND	DIST FROM WALL (cm)	MINIMUM MAGNETIC FIELD (mG)	MAXIMUM MAGNETIC FIELD (mG)	AVERAGE MAGNETIC FIELD (mG)	STANDARD DEVIATION (mG)	COEFFICIENT OF VARIATION (%)
STATIC	10	578.03	1270.14	780.40	201.12	25.77
	60	522.05	1213.19	728.07	200.85	27.59
	110	433.06	1062.49	626.71	174.35	27.82
	160	443.10	1000.07	617.99	150.22	24.31
5-45Hz	10	0.56	14.65	3.11	3.61	116.27
LOW FREQ	60	0.58	13.85	2.94	3.39	115.35
	110	0.48	12.48	2.65	3.08	116.54
	160	0.47	11.73	2.49	2.87	114.97
50-60Hz	10	0.95	3.21	1.64	0.54	33.16
PWR FREQ	60	0.62	2.82	1.13	0.44	39.23
	110	0.64	2.47	1.08	0.39	36.64
	160	0.70	2.34	1.19	0.41	34.80
65-300Hz	10	4.78	9.61	6.14	1.32	21.54
PWR HARM	60	4.40	8.87	5.66	1.22	21.54
	110	3.83	7.72	4.95	1.07	21.63
	160	3.50	7.08	4.52	0.98	21.66
305-2560Hz	10	8.92	15.52	11.19	2.05	18.30
HIGH FREQ	60	8.17	14.07	10.18	1.83	17.95
	110	7.14	12.26	8.88	1.61	18.18
	160	6.64	11.14	8.14	1.46	17.87
5-2560Hz	10	10.53	22.46	13.60	3.06	22.48
ALL FREQ	60	9.58	20.69	12.40	2.83	22.85
	110	8.38	18.42	10.88	2.54	23.33
	160	7.71	16.85	10.01	2.32	23.21

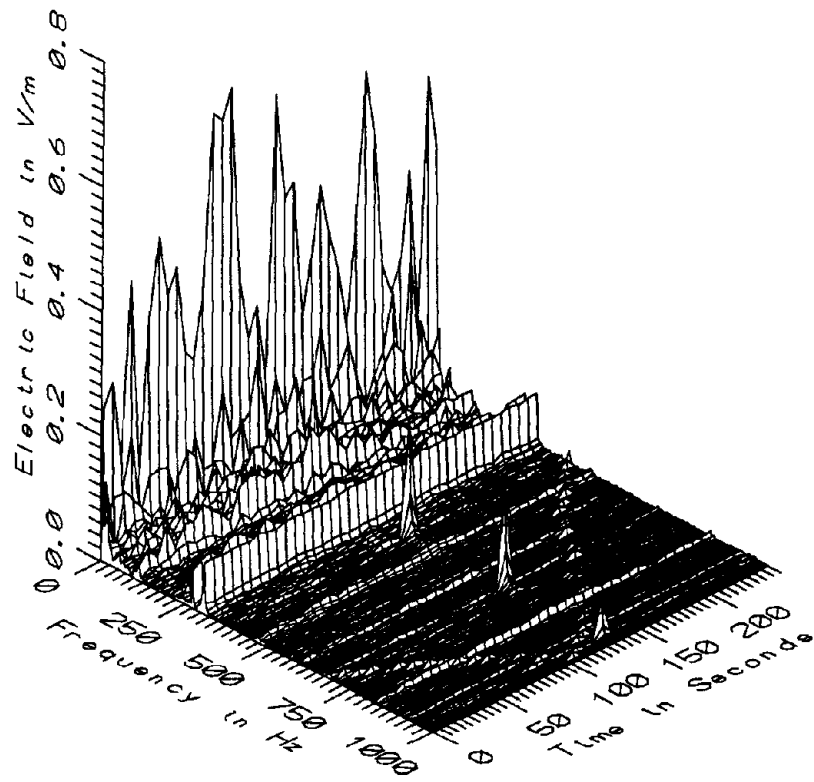

MET044 - ELECTRIC FIELD AT TRACTION POWER SUPPLY STATION

**APPENDIX A0**  
**DATASET MET045**  
**AT SHADY GROVE TRACTION POWER SUPPLY STATION**

Measurement Setup Code:        Staff:    50    Reference: -  
   Drawing:  A-7

Vehicle Status:                NA

Measurement Date:             May 20, 1992

Measurement Time:            Start:    10:00:56  
   End:      10:04:58

Number of Samples:            43

Programmed Sample Interval:   5 sec

Actual Sample Interval:      5.8 sec

**Frequency Spectrum Parameters**

<u>Probe Type:</u>	<u>Wideband</u>	<u>Static</u>
Maximum Frequency (Hz)	2560	100
Minimum Frequency (Hz)	5	0
Spectral Bandwidth (Hz)	5	1

Missing Data: No reference probe

Saturated Data: None

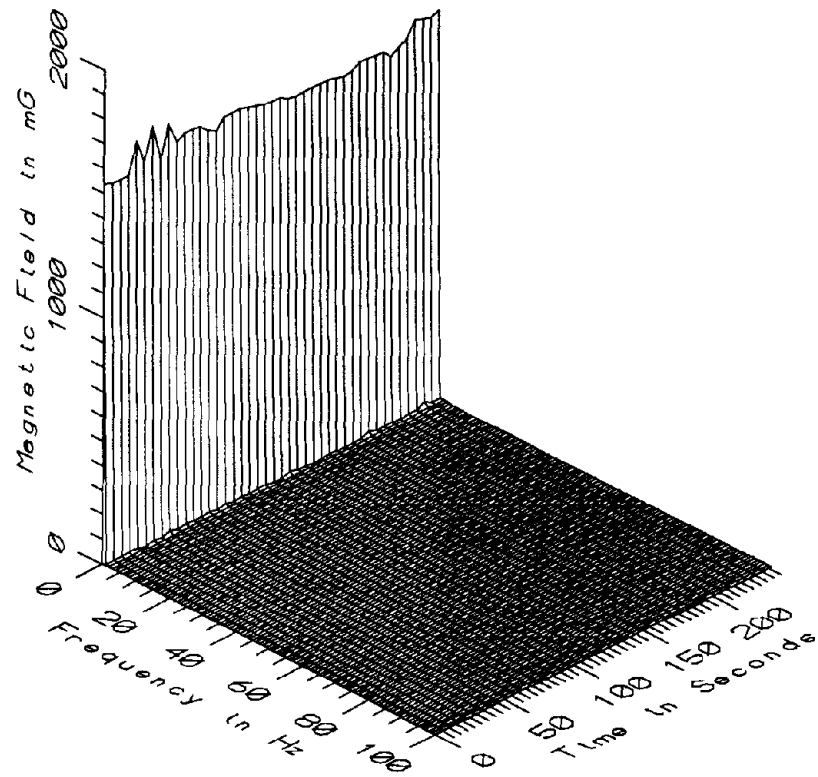

MET045 - 10cm FROM WEST WALL OF TRACTION POWER SUPPLY STATION

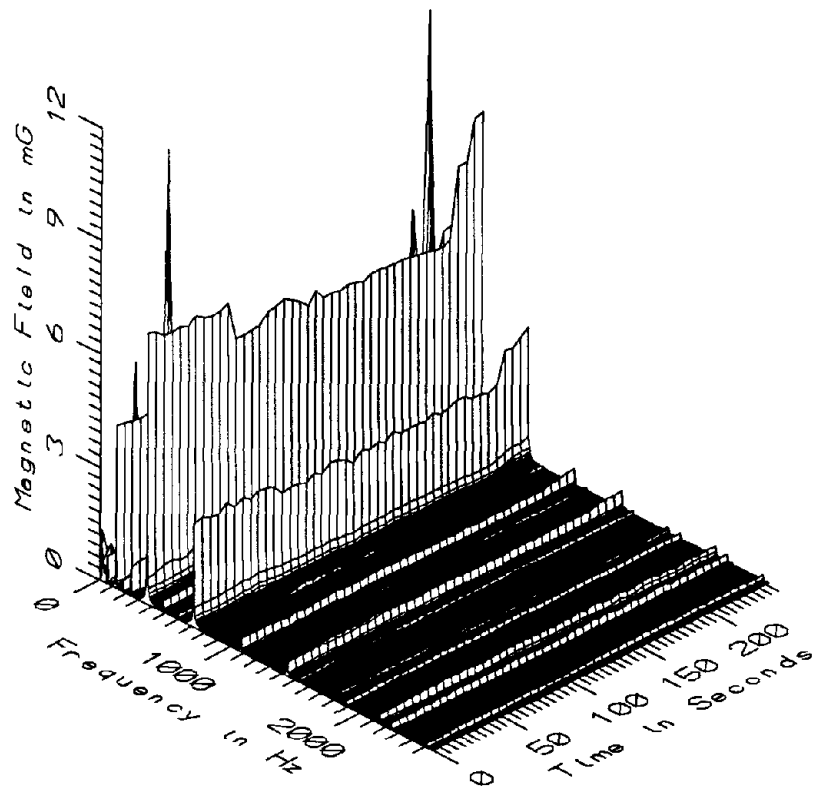

MET045 - 10cm FROM WEST WALL OF TRACTION POWER SUPPLY STATION



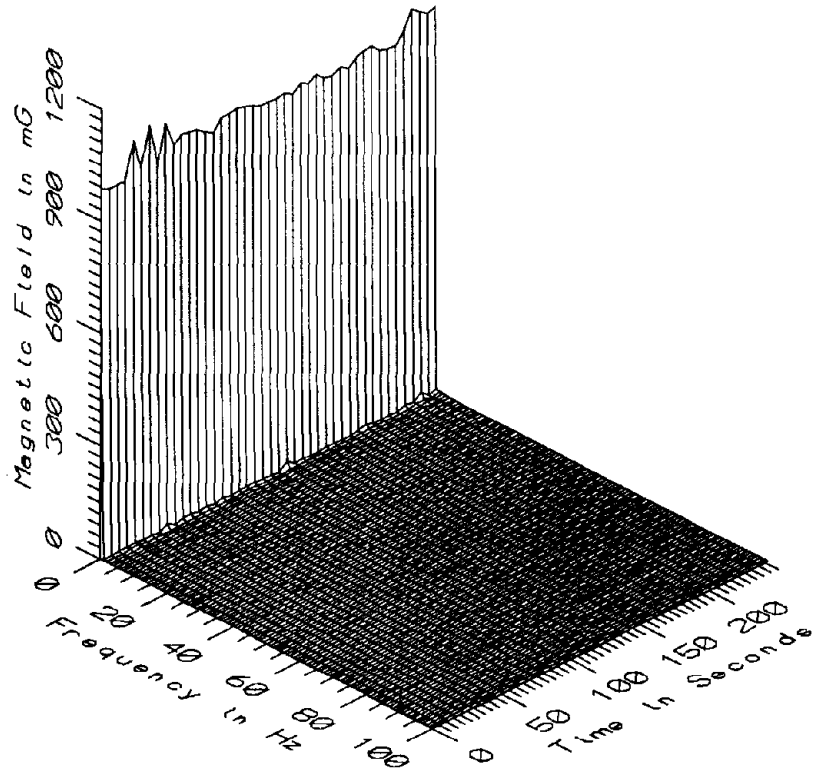

MET045 - 60cm FROM WEST WALL OF TRACTION POWER SUPPLY STATION

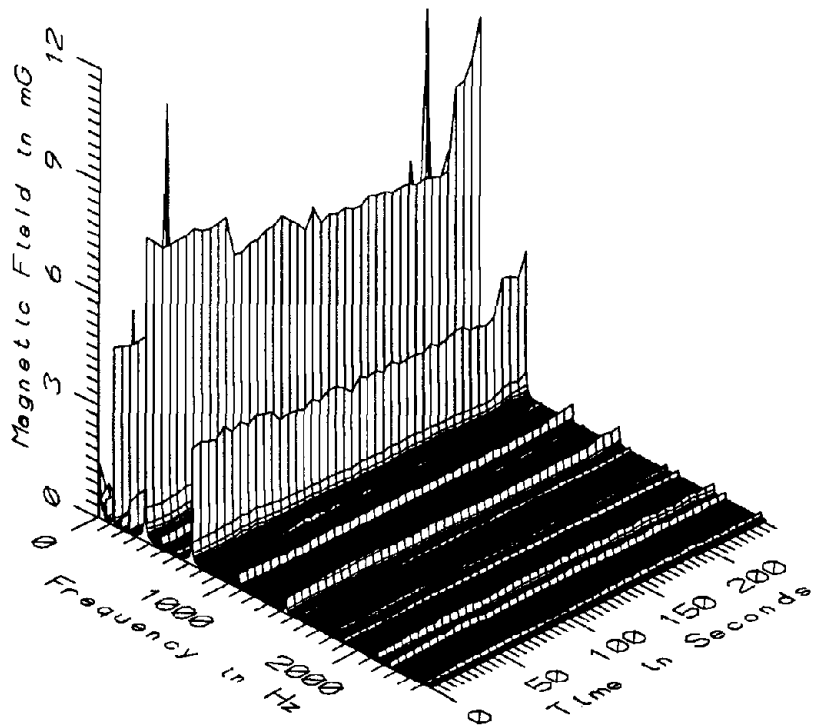

MET045 - 60cm FROM WEST WALL OF TRACTION POWER SUPPLY STATION

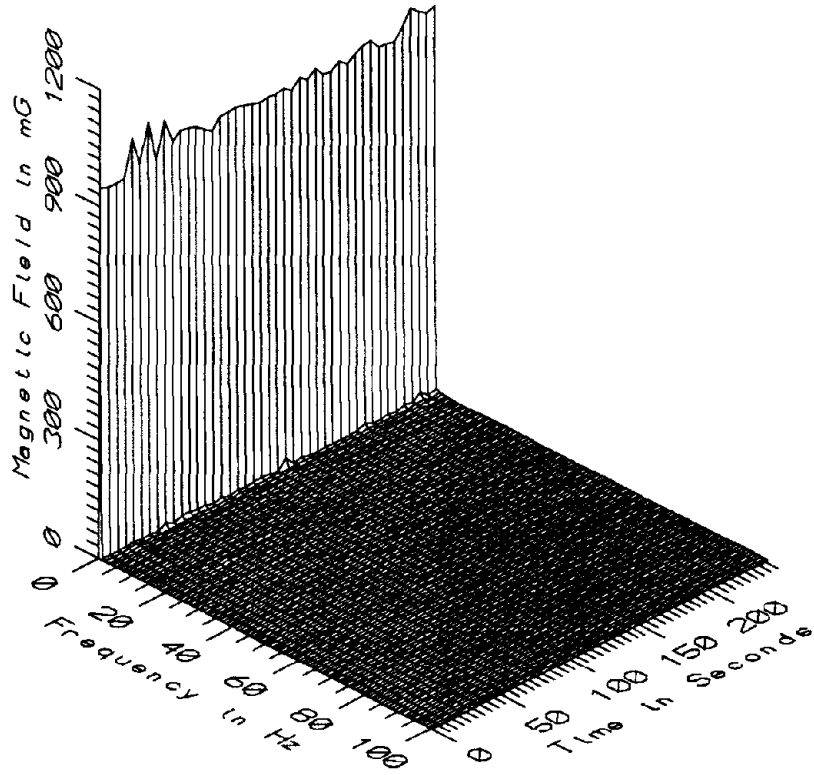

MET045 - 110cm FROM WEST WALL OF TRACTION POWER SUPPLY STATION

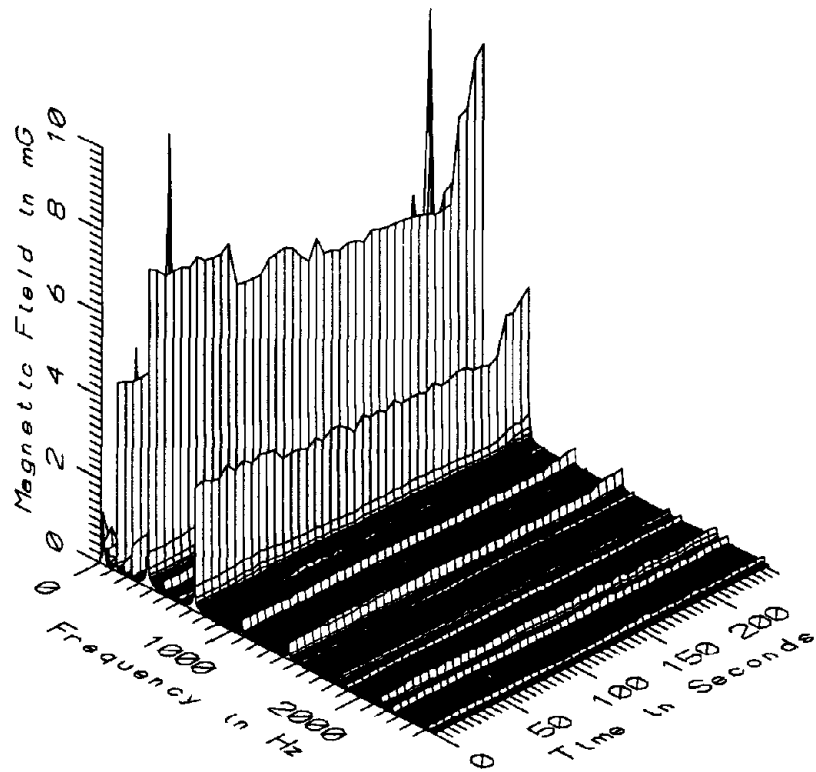

MET045 - 110cm FROM WEST WALL OF TRACTION POWER SUPPLY STATION

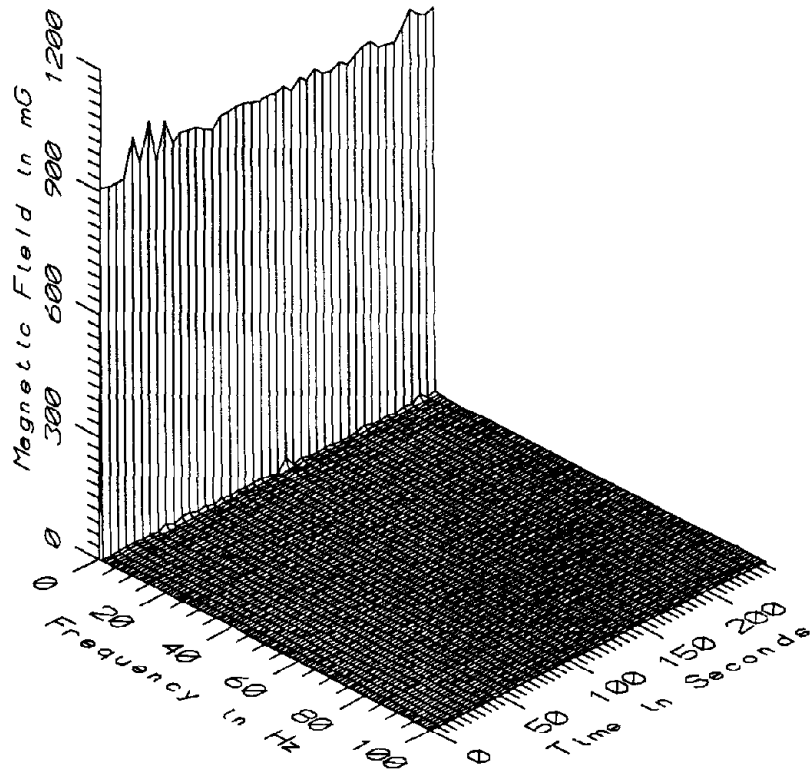

MET045 - 160cm FROM WEST WALL OF TRACTION POWER SUPPLY STATION

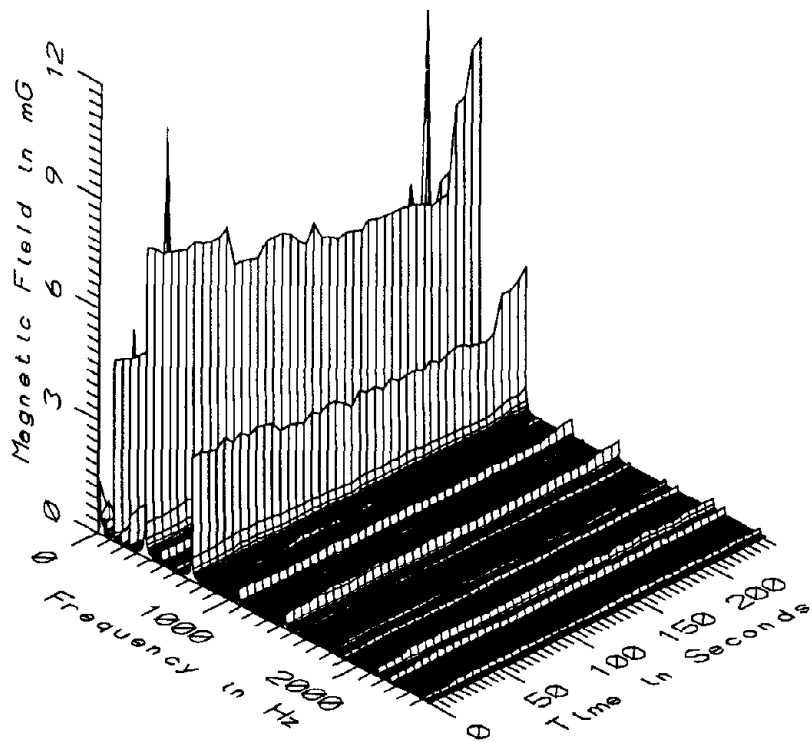

MET045 - 160cm FROM WEST WALL OF TRACTION POWER SUPPLY STATION

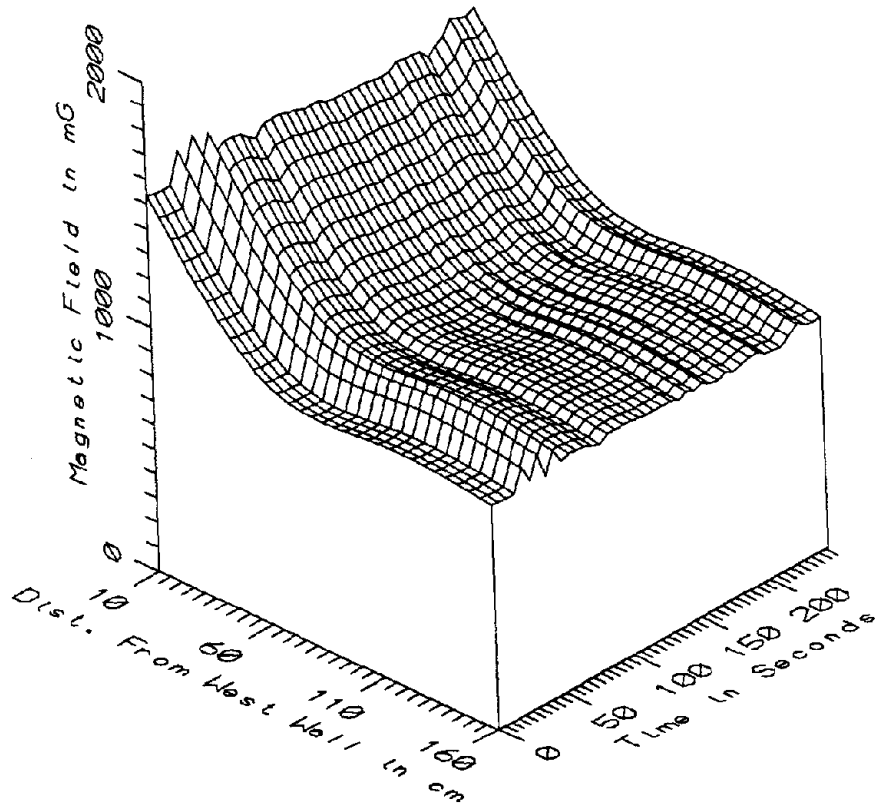

MET045 - TRACTION POWER SUPPLY STATION - STATIC

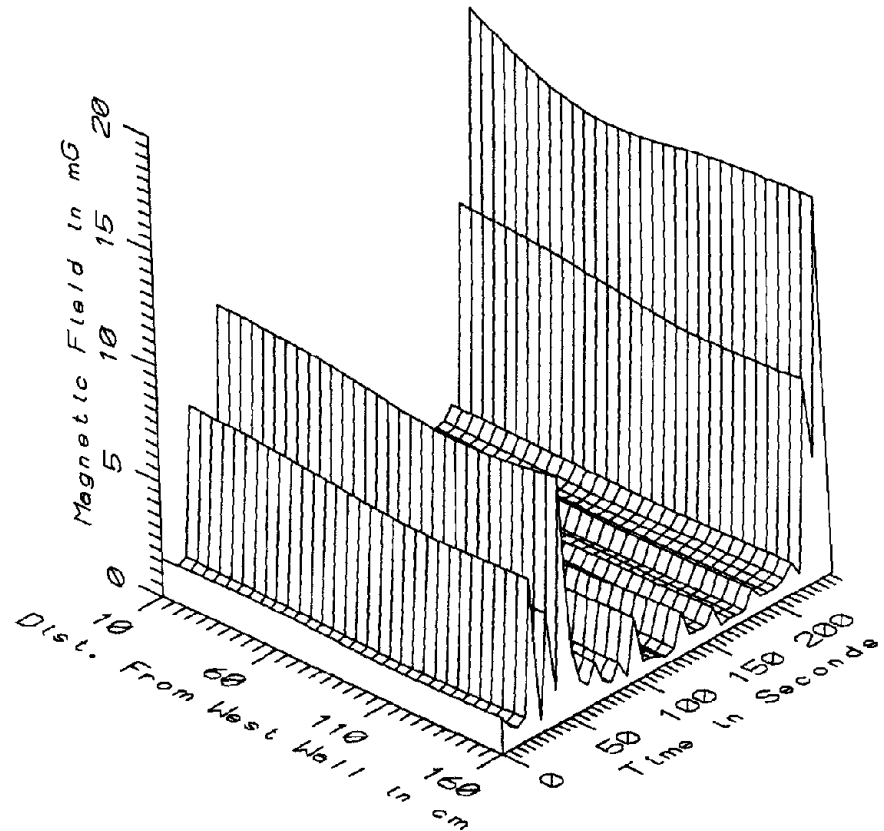

MET045 - TRACTION POWER SUPPLY STATION - LOW FREQ, 5-45Hz

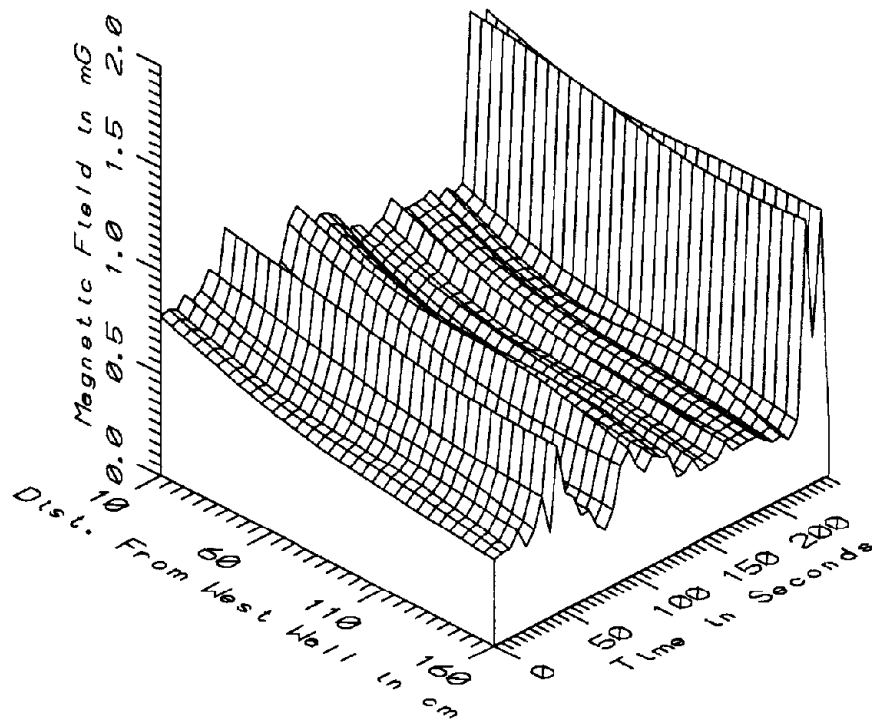

MET045 - TRACTION POWER SUPPLY STATION - POWER FREQ, 50-60Hz

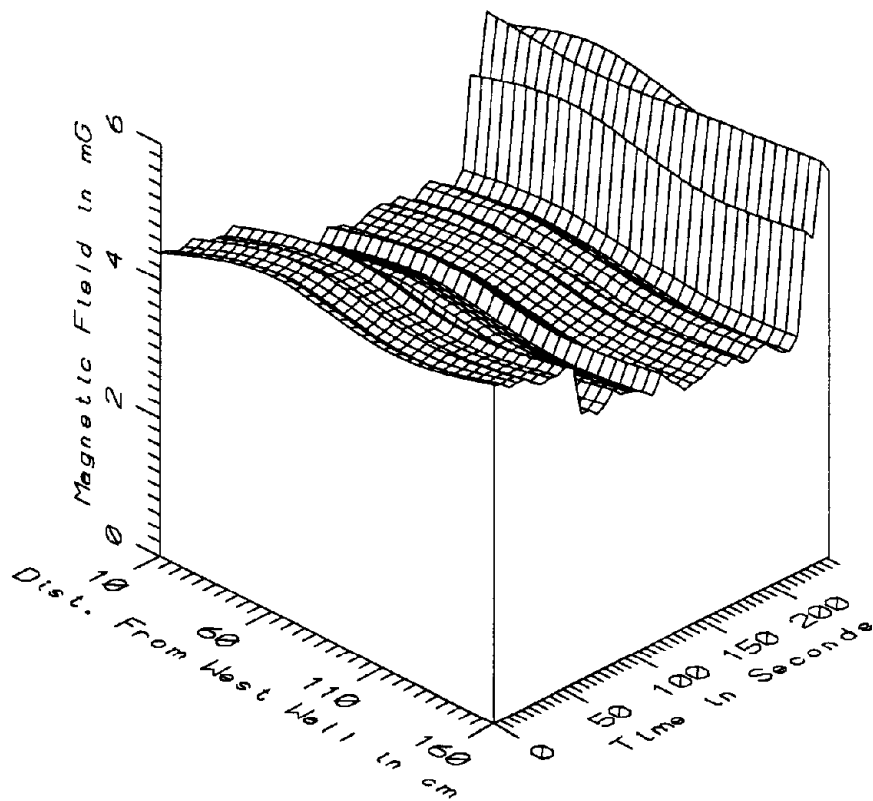

MET045 - TRACTION POWER SUPPLY STATION - POWER HARM, 65-300Hz

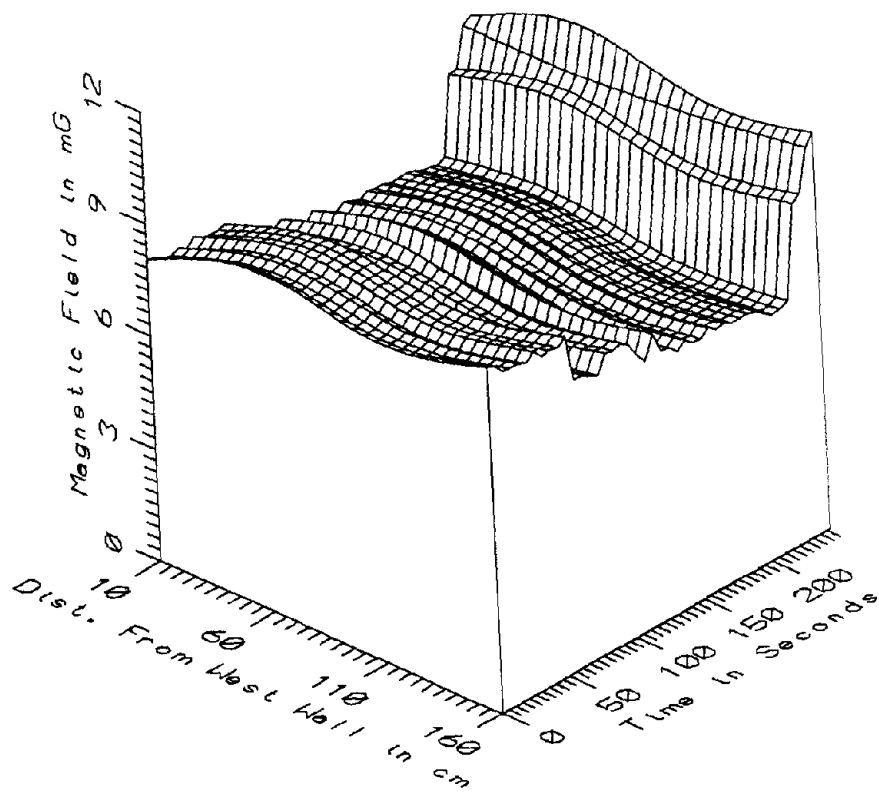

MET045 - TRACTION POWER SUPPLY STATION - HIGH FREQ, 305-2560Hz

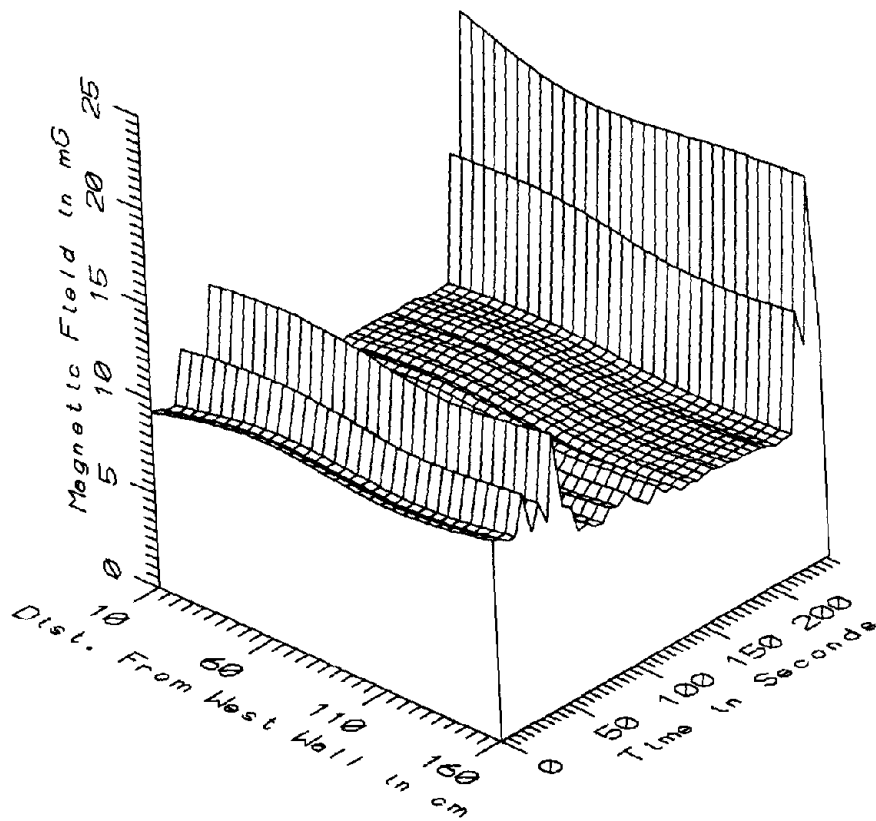

MET045 - TRACTION POWER SUPPLY STATION - ALL FREQ, 5-2560Hz

MET045 - SHADY GROVE T.P.S.S. FROM WEST WALL		TOTAL OF 43 SAMPLES				
FREQUENCY BAND	DIST FROM WALL (cm)	MINIMUM MAGNETIC FIELD (mG)	MAXIMUM MAGNETIC FIELD (mG)	AVERAGE MAGNETIC FIELD (mG)	STANDARD DEVIATION (mG)	COEFFICIENT OF VARIATION (%)
STATIC	10	1473.28	1675.71	1541.76	42.20	2.74
	60	973.29	1093.30	1005.66	27.55	2.74
	110	939.32	1054.16	971.62	25.26	2.60
	160	901.08	1012.87	931.88	24.09	2.58
5-45HZ LOW FREQ	10	0.34	17.90	2.16	3.47	160.82
	60	0.32	15.71	2.02	3.18	157.55
	110	0.25	16.10	1.99	3.11	156.71
	160	0.35	16.50	2.08	3.19	153.02
50-60HZ PWR FREQ	10	0.65	1.51	0.82	0.18	21.73
	60	0.42	1.42	0.62	0.20	32.80
	110	0.35	1.31	0.55	0.20	36.92
	160	0.28	1.32	0.47	0.22	46.54
65-300HZ PWR HARM	10	3.22	5.54	3.82	0.55	14.47
	60	3.39	5.75	4.11	0.60	14.50
	110	3.18	5.62	3.90	0.61	15.53
	160	3.27	5.80	4.07	0.65	16.04
305-2560HZ HIGH FREQ	10	6.21	9.65	7.13	0.85	11.90
	60	6.57	10.73	7.78	0.96	12.34
	110	6.20	10.15	7.39	0.98	13.32
	160	6.43	10.57	7.80	1.09	13.91
5-2560HZ ALL FREQ	10	7.16	21.07	8.79	2.56	29.11
	60	7.52	19.22	9.38	2.30	24.53
	110	7.07	19.73	8.91	2.35	26.36
	160	7.30	20.34	9.37	2.44	26.07

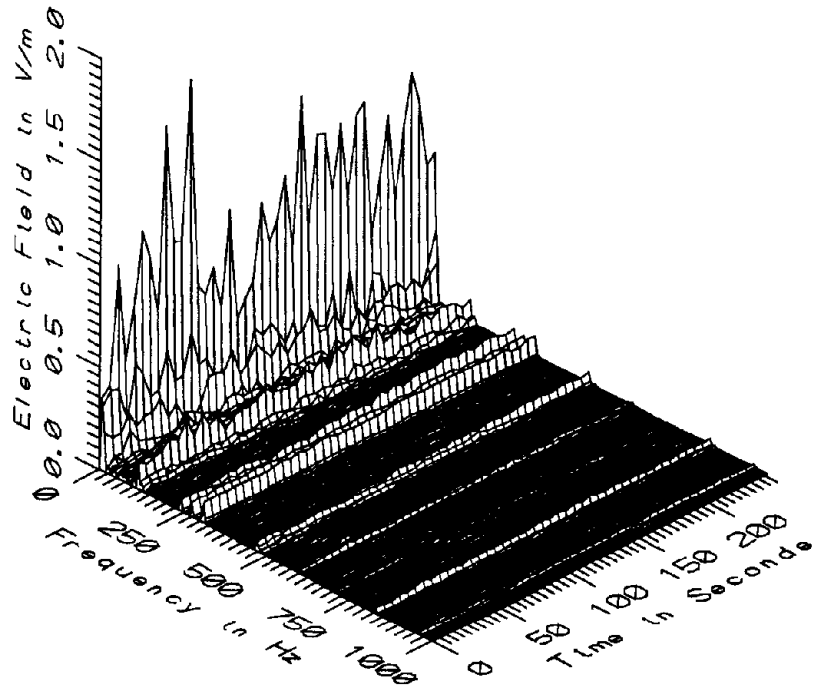

MET045 - ELECTRIC FIELD AT TRACTION POWER SUPPLY STATION



APPENDIX AP

DATASET MET046  
SHADY GROVE DISPATCHER'S ROOM, AT DISPATCHER'S CHAIR

Measurement Setup Code:        Staff:    52    Reference: -  
   Drawing:  A-8

Vehicle Status:                NA

Measurement Date:              May 20, 1992

Measurement Time:              Start:    11:10:47  
   End:      11:12:16

Number of Samples:             19

Programmed Sample Interval:    5 sec

Actual Sample Interval:        4.9 sec

**Frequency Spectrum Parameters**

<u>Probe Type:</u>	<u>Wideband</u>	<u>Static</u>
Maximum Frequency (Hz)	2560	100
Minimum Frequency (Hz)	5	0
Spectral Bandwidth (Hz)	5	1

Missing Data: No reference probe

Saturated Data: None

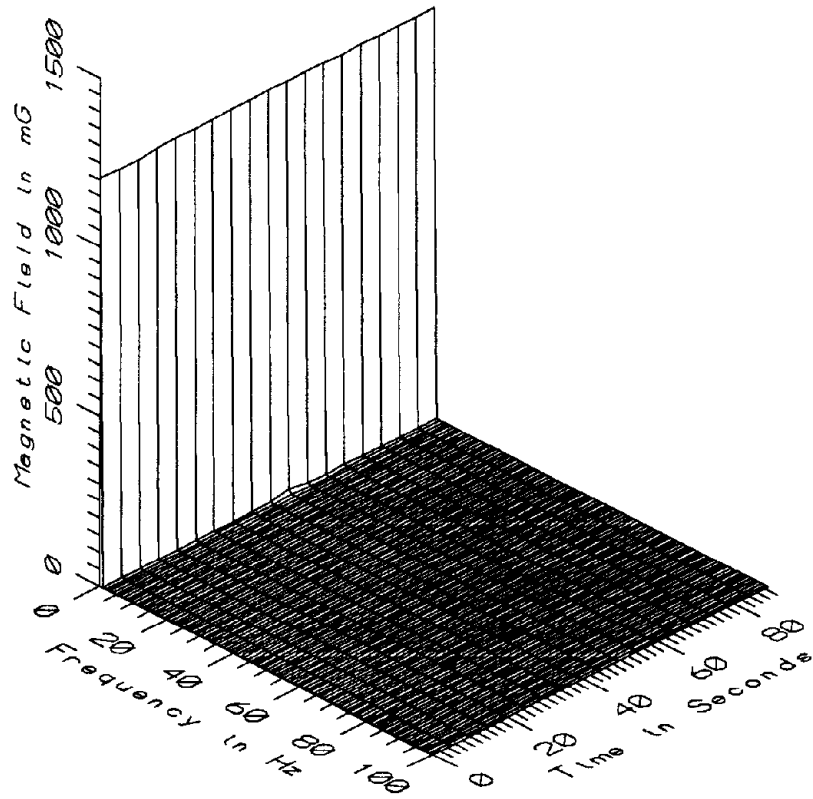

MET046 - 10cm ABOVE FLOOR AT SHADY GROVE DISPATCHER'S SEAT

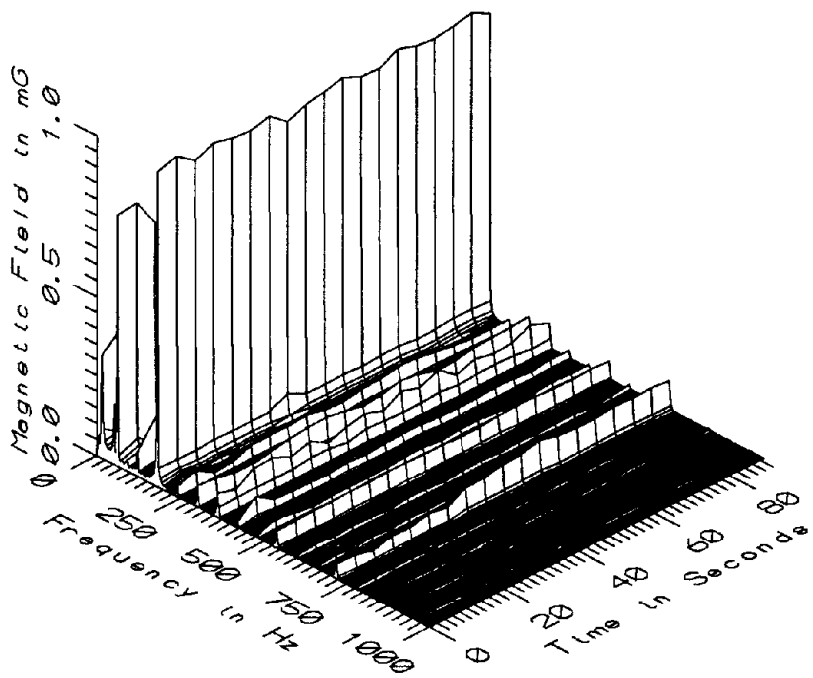

MET046 - 10cm ABOVE FLOOR AT SHADY GROVE DISPATCHER'S SEAT

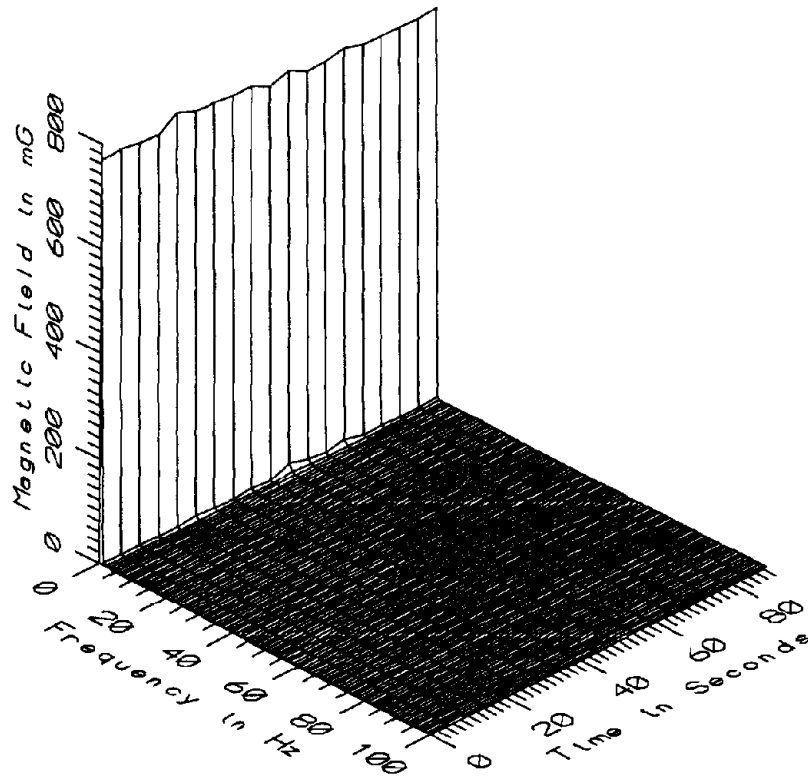

MET046 - 60cm ABOVE FLOOR AT SHADY GROVE DISPATCHER'S SEAT

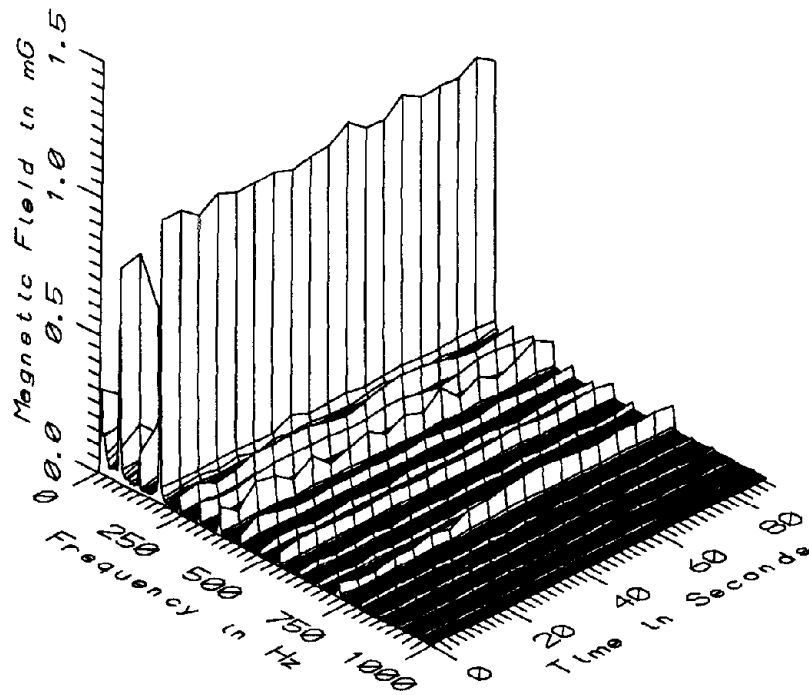

MET046 - 60cm ABOVE FLOOR AT SHADY GROVE DISPATCHER'S SEAT

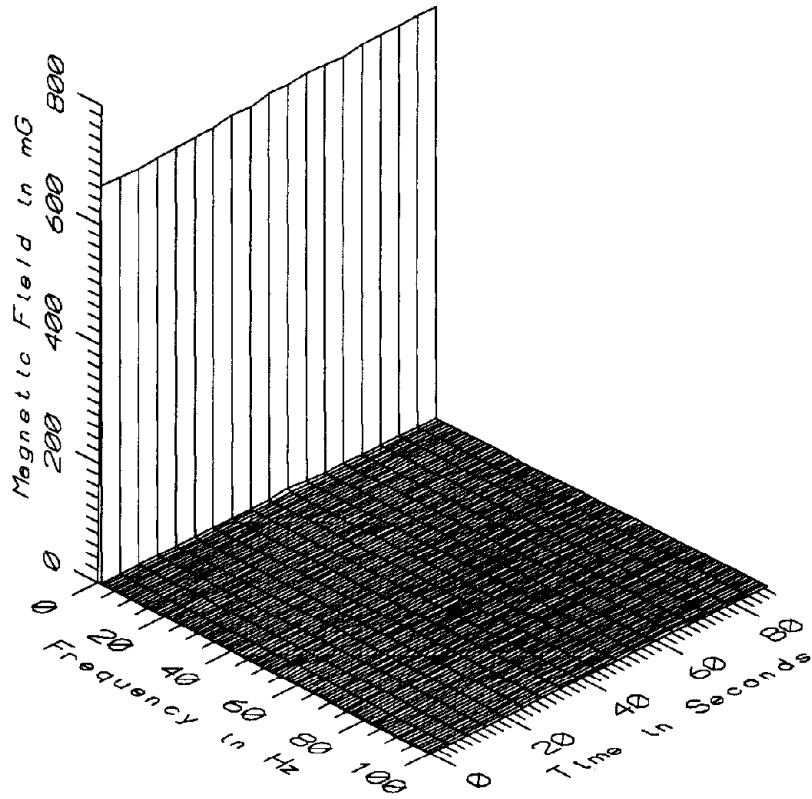

MET046 - 110cm ABOVE FLOOR AT SHADY GROVE DISPATCHER'S SEAT

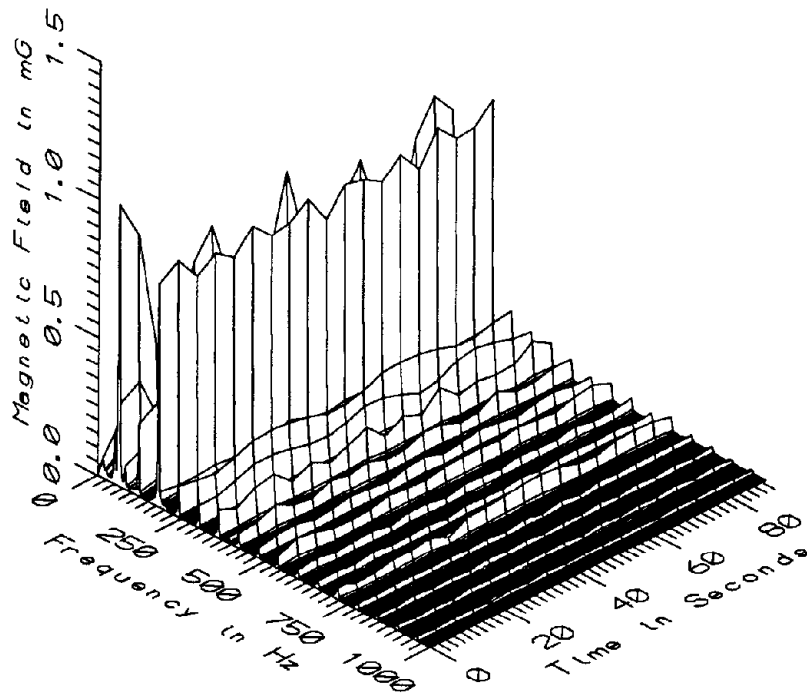

MET046 - 110cm ABOVE FLOOR AT SHADY GROVE DISPATCHER'S SEAT

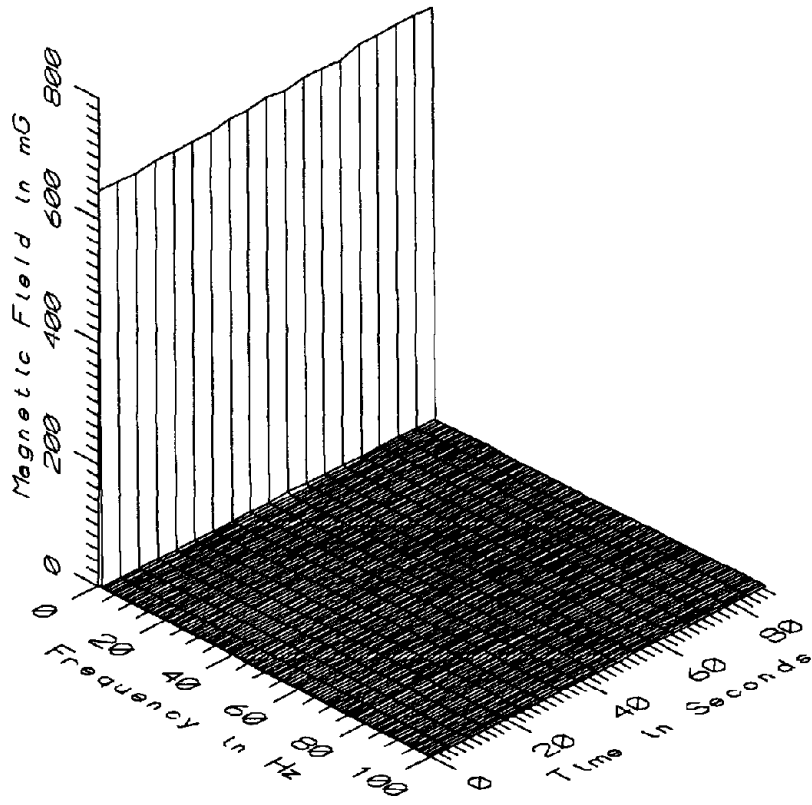

MET046 - 160cm ABOVE FLOOR AT SHADY GROVE DISPATCHER'S SEAT

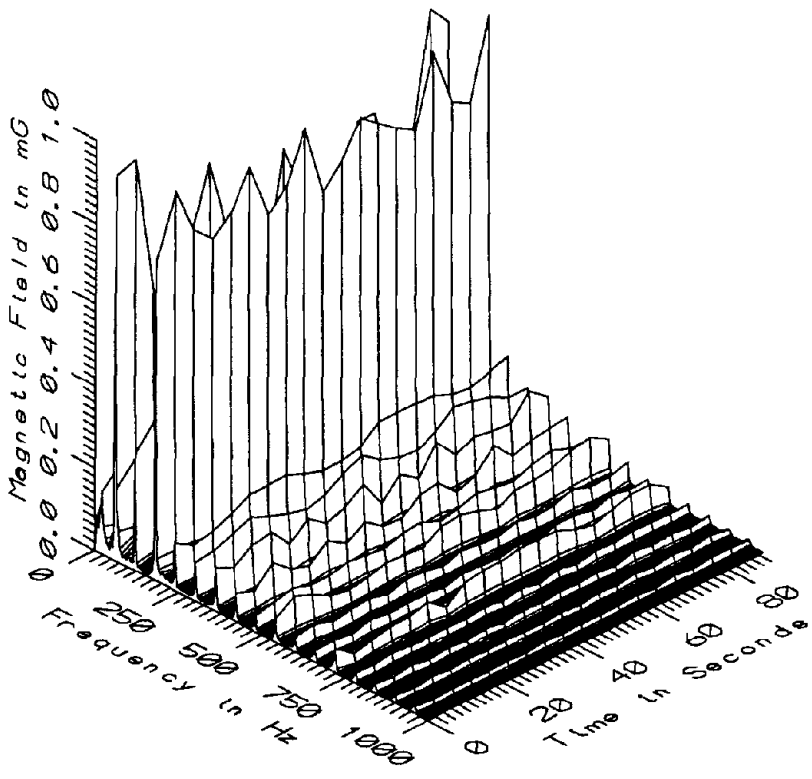

MET046 - 160cm ABOVE FLOOR AT SHADY GROVE DISPATCHER'S SEAT

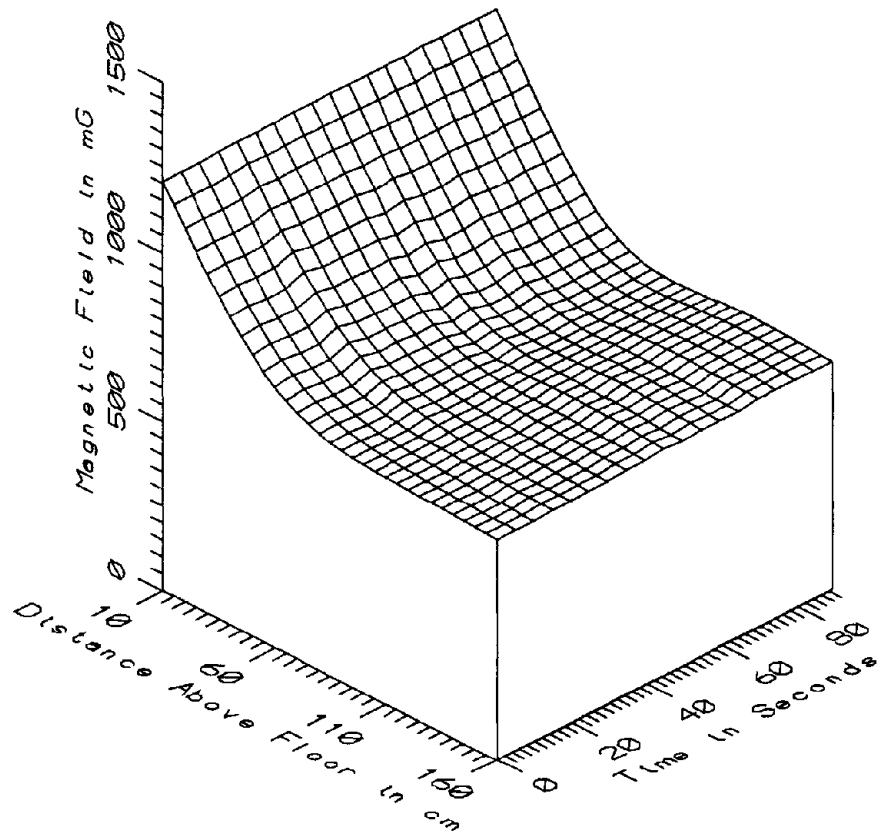

MET046 - SHADY GROVE DISPATCHER'S SEAT - STATIC

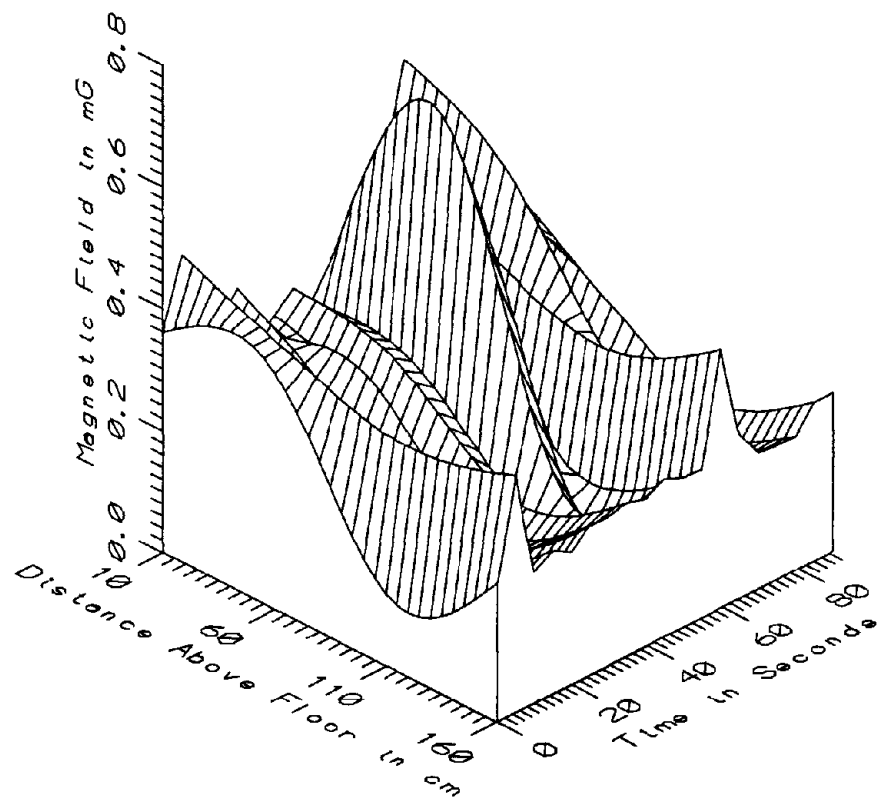

MET046 - SHADY GROVE DISPATCHER'S SEAT - LOW FREQ, 5-45Hz

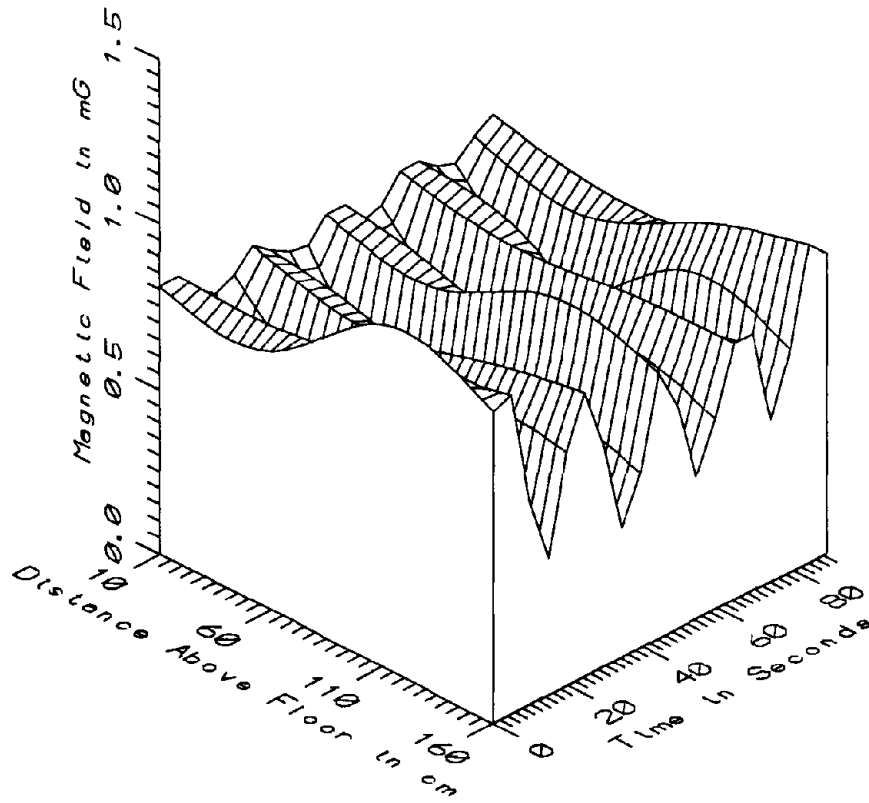

MET046 - SHADY GROVE DISPATCHER'S SEAT - POWER FREQ, 50-60Hz

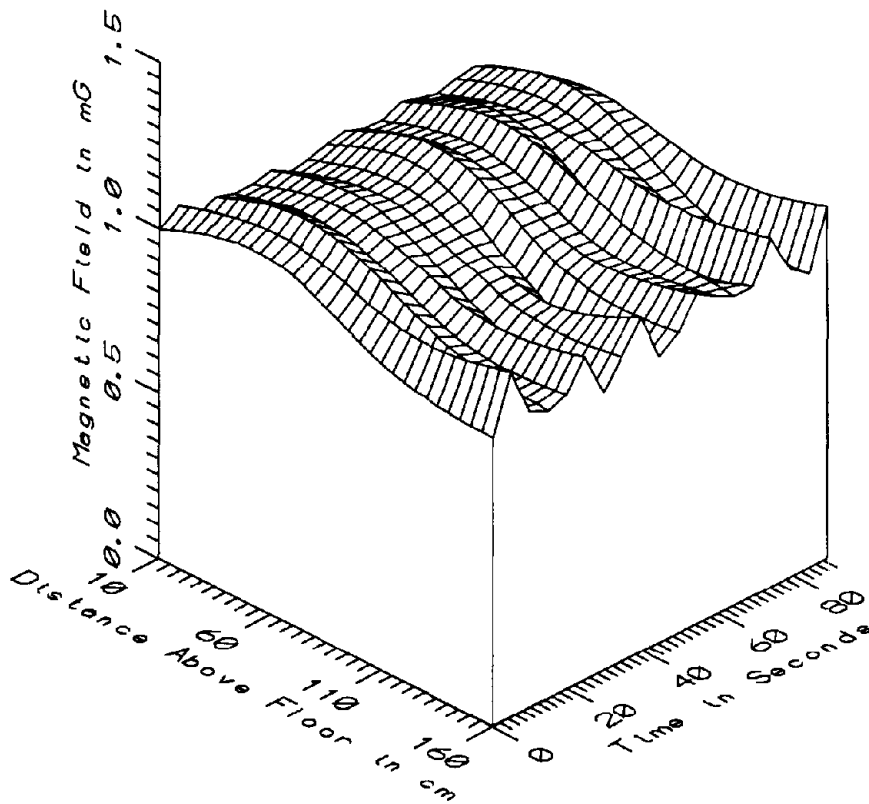

MET046 - SHADY GROVE DISPATCHER'S SEAT - POWER HARM, 65-300Hz

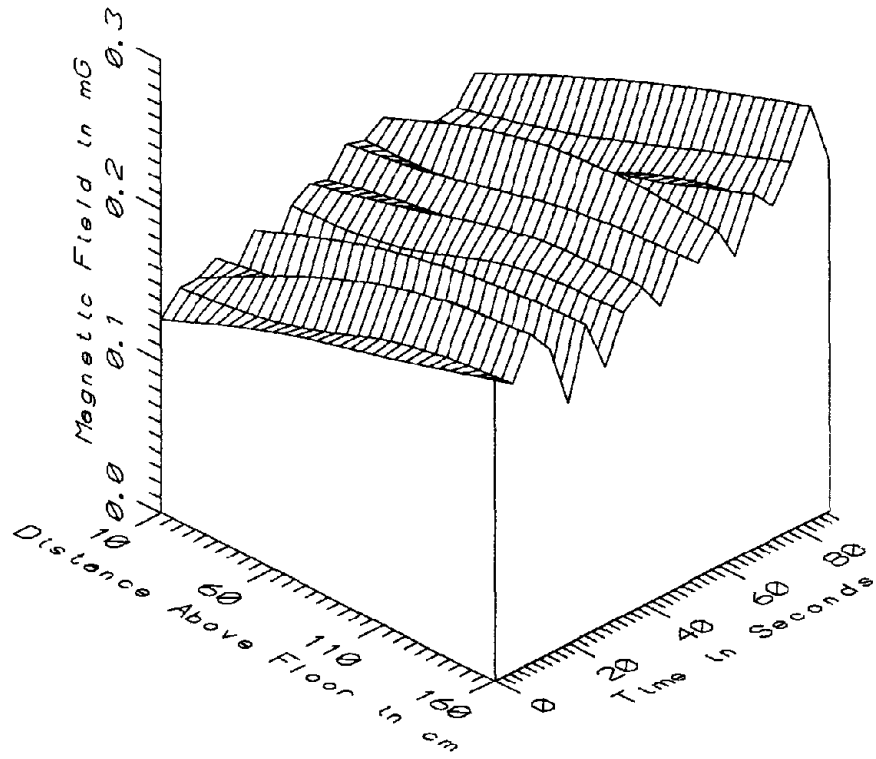

MET046 - SHADY GROVE DISPATCHER'S SEAT - HIGH FREQ, 305-2560Hz

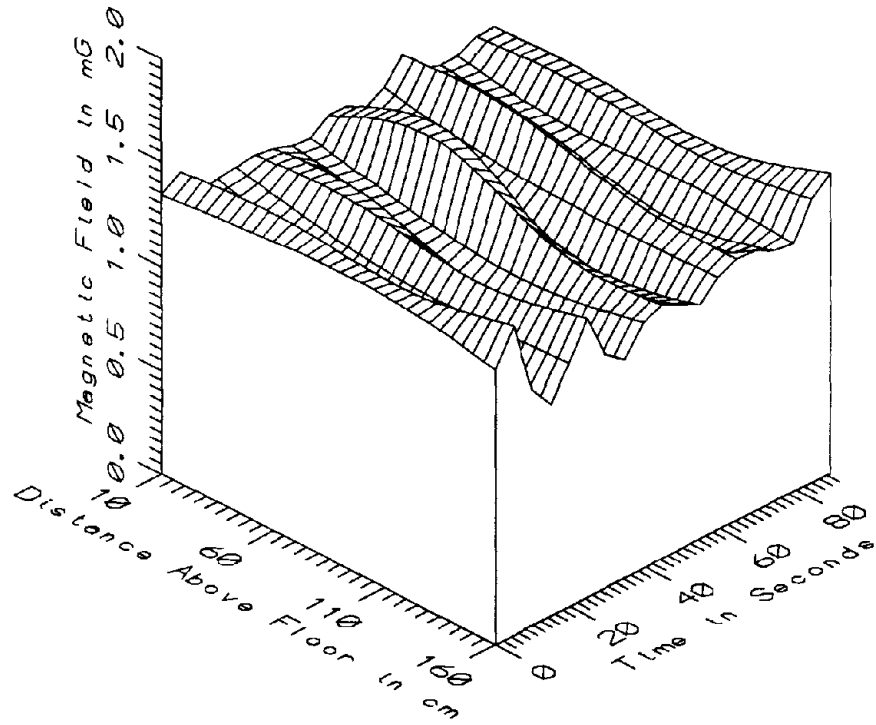

MET046 - SHADY GROVE DISPATCHER'S SEAT - ALL FREQ, 5-2560Hz



MET046 - IN DISPATCHER'S ROOM AT DISPATCHER'S CHAIR		TOTAL OF 19 SAMPLES				
FREQUENCY BAND	HEIGHT ABOVE FLOOR (cm)	MINIMUM MAGNETIC FIELD (mG)	MAXIMUM MAGNETIC FIELD (mG)	AVERAGE MAGNETIC FIELD (mG)	STANDARD DEVIATION (mG)	COEFFICIENT OF VARIATION (%)
STATIC	10	1204.53	1218.24	1212.62	3.80	0.31
	60	739.08	788.72	758.94	14.83	1.95
	110	662.31	687.19	675.98	8.99	1.33
	160	644.72	674.94	660.16	10.60	1.61
5-45Hz LOW FREQ	10	0.26	0.61	0.35	0.09	24.70
	60	0.21	0.67	0.32	0.13	41.58
	110	0.10	0.35	0.16	0.07	44.27
	160	0.22	0.42	0.26	0.05	21.35
50-60Hz PWR FREQ	10	0.70	0.82	0.76	0.04	5.31
	60	0.23	0.81	0.60	0.17	27.79
	110	0.33	1.04	0.65	0.19	29.65
	160	0.39	0.96	0.69	0.19	27.03
65-300Hz PWR HARM	10	0.97	1.04	0.99	0.02	1.62
	60	1.02	1.10	1.06	0.02	2.25
	110	0.85	1.00	0.93	0.05	5.02
	160	0.84	1.06	0.94	0.07	7.24
305-2560Hz HIGH FREQ	10	0.13	0.19	0.16	0.02	11.32
	60	0.14	0.22	0.18	0.02	11.84
	110	0.16	0.25	0.20	0.02	10.51
	160	0.16	0.27	0.21	0.03	12.35
5-2560Hz ALL FREQ	10	1.25	1.43	1.31	0.05	3.56
	60	1.13	1.46	1.28	0.11	8.45
	110	1.00	1.41	1.17	0.12	10.65
	160	1.01	1.48	1.22	0.12	10.05

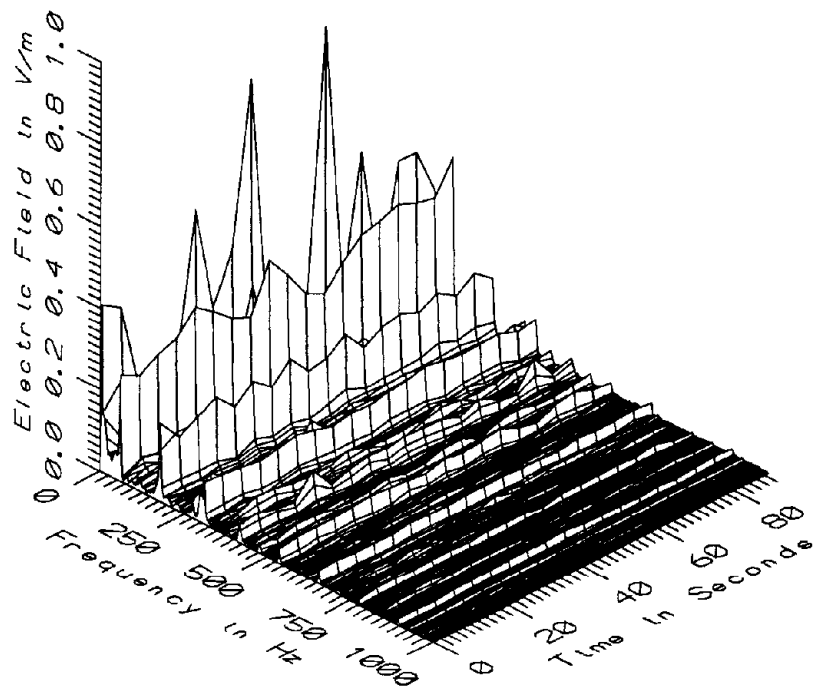

MET046 - ELECTRIC FIELD AT SHADY GROVE DISPATCHER'S SEAT

APPENDIX AQ

DATASET MET047  
SHADY GROVE DISPATCHER'S ROOM, FROM MONITORS

Measurement Setup Code:           Staff:     53   Reference:  -  
  Drawing:  A-8

Vehicle Status:                    NA

Measurement Date:                 May 20, 1992

Measurement Time:                 Start:     11:13:11  
  End:       11:14:41

Number of Samples:                 19

Programmed Sample Interval:       5 sec

Actual Sample Interval:            5.0 sec

Frequency Spectrum Parameters

<u>Probe Type:</u>	<u>Wideband</u>	<u>Static</u>
Maximum Frequency (Hz)	2560	100
Minimum Frequency (Hz)	5	0
Spectral Bandwidth (Hz)	5	1

Missing Data: No reference probe

Saturated Data: None

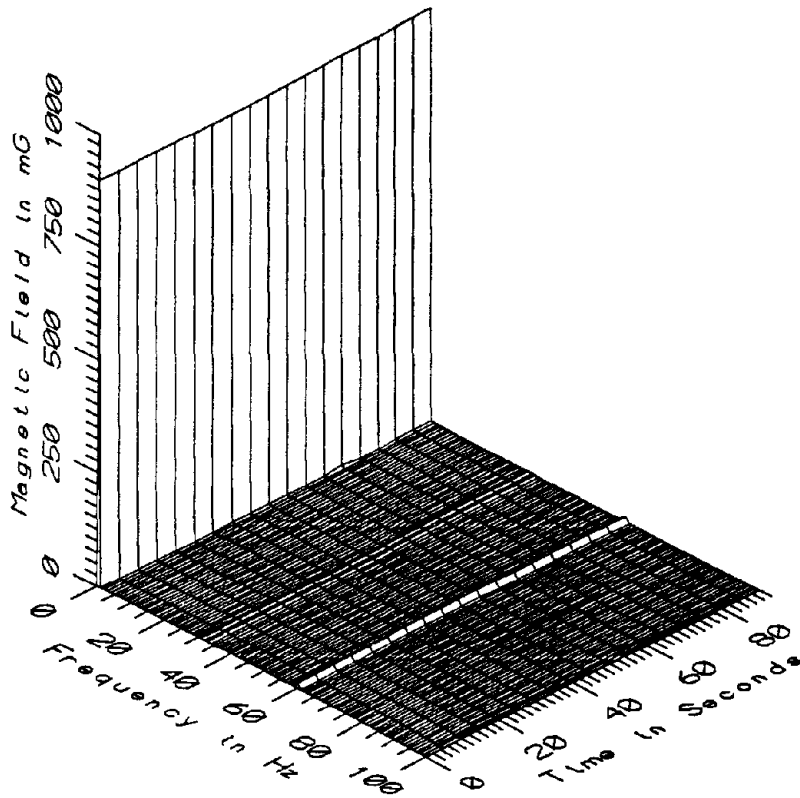

MET047 - 10cm FROM DISPATCHER'S MONITORS, 1.25M ABOVE FLOOR

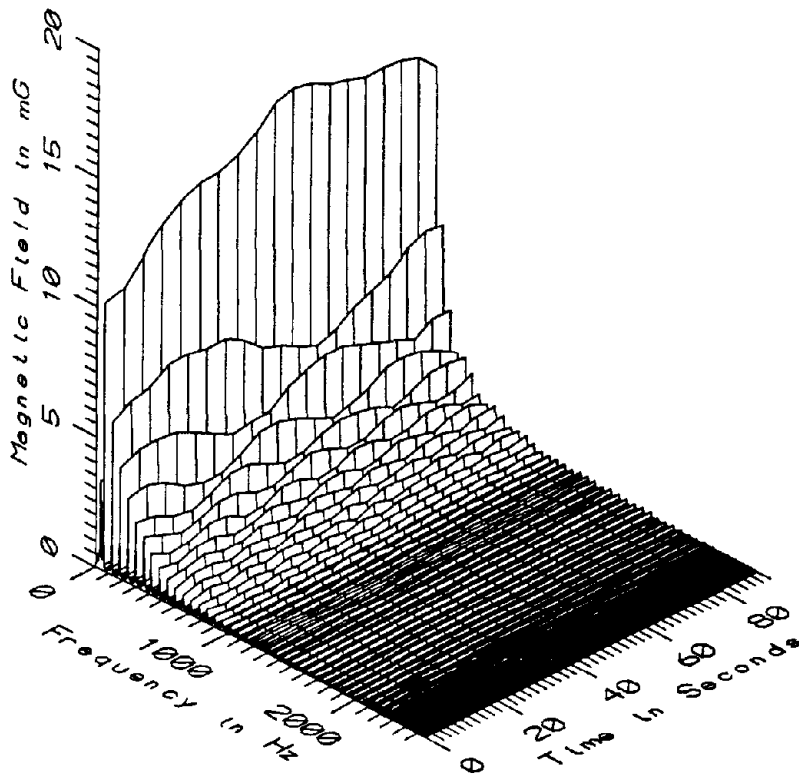

MET047 - 10cm FROM DISPATCHER'S MONITORS, 1.25M ABOVE FLOOR

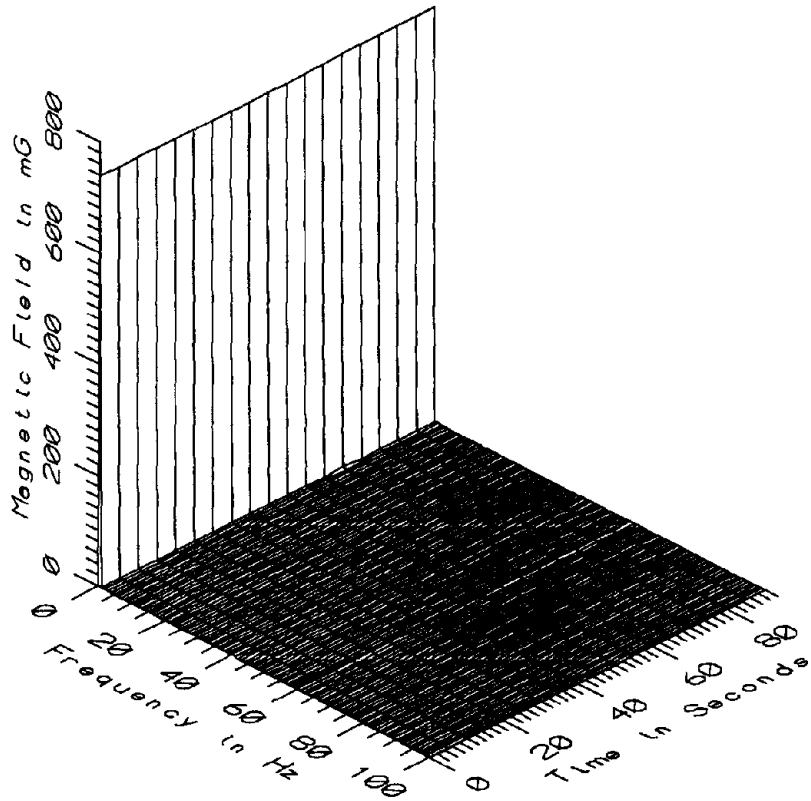

MET047 - 60cm FROM DISPATCHER'S MONITORS, 1.25M ABOVE FLOOR

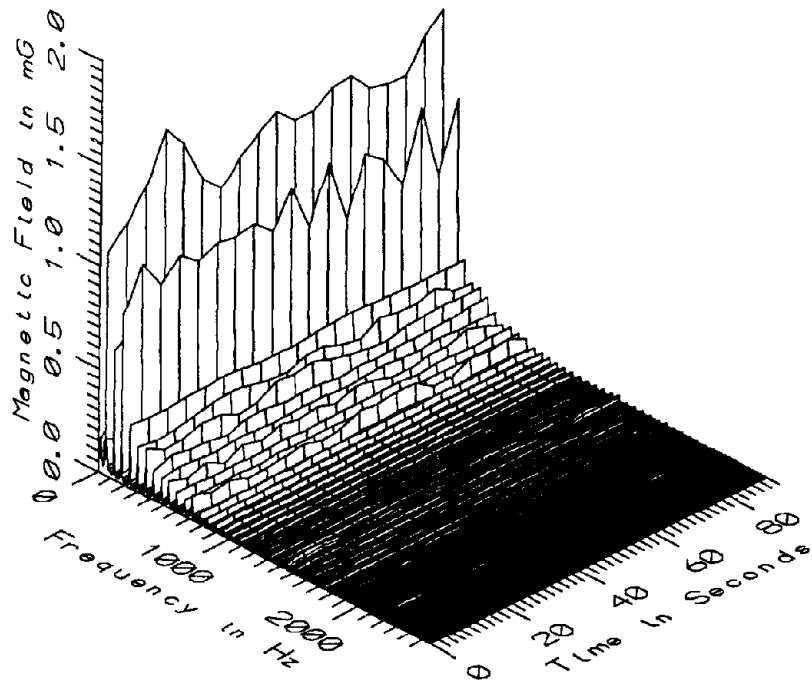

MET047 - 60cm FROM DISPATCHER'S MONITORS, 1.25M ABOVE FLOOR

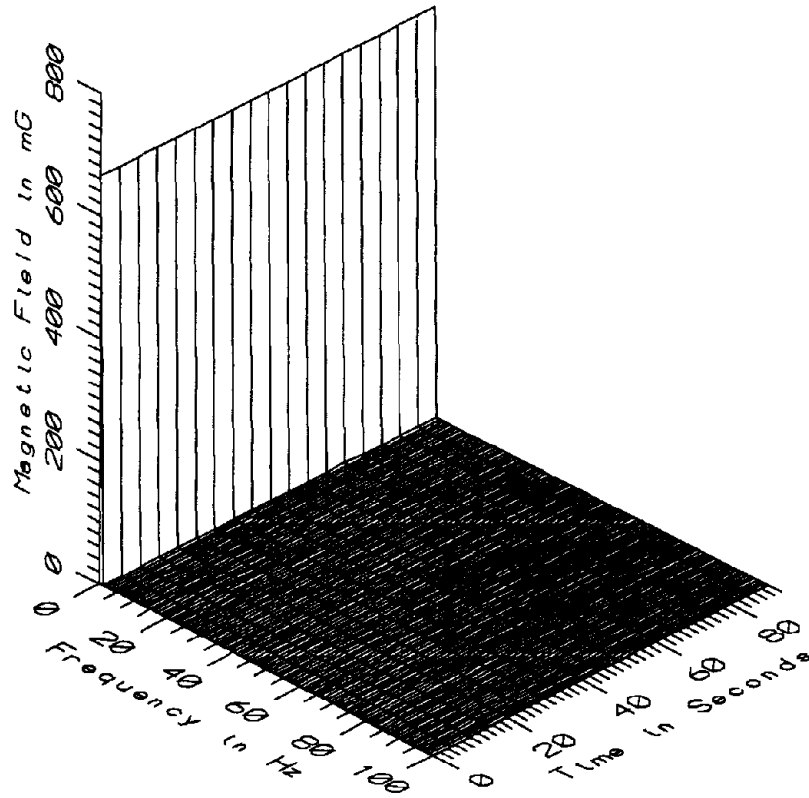

MET047 - 110cm FROM DISPATCHER'S MONITORS, 1.25M ABOVE FLOOR

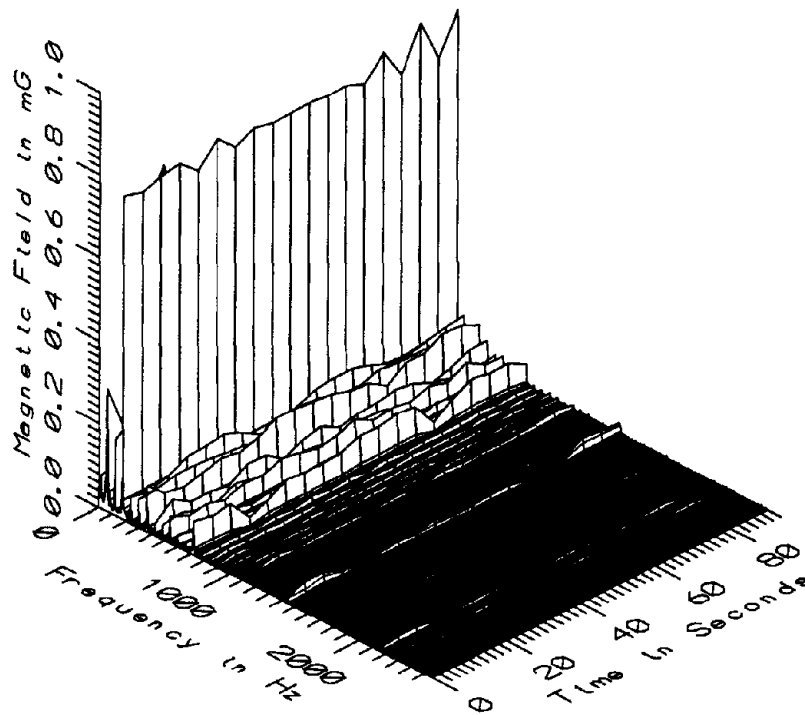

MET047 - 110cm FROM DISPATCHER'S MONITORS, 1.25M ABOVE FLOOR

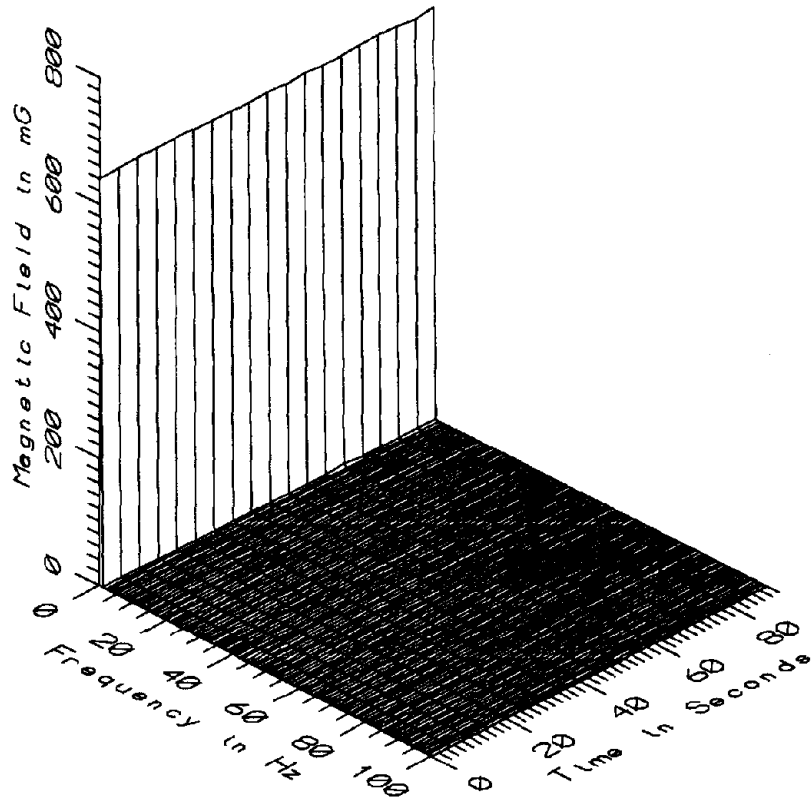

MET047 - 160cm FROM DISPATCHER'S MONITORS, 1.25M ABOVE FLOOR

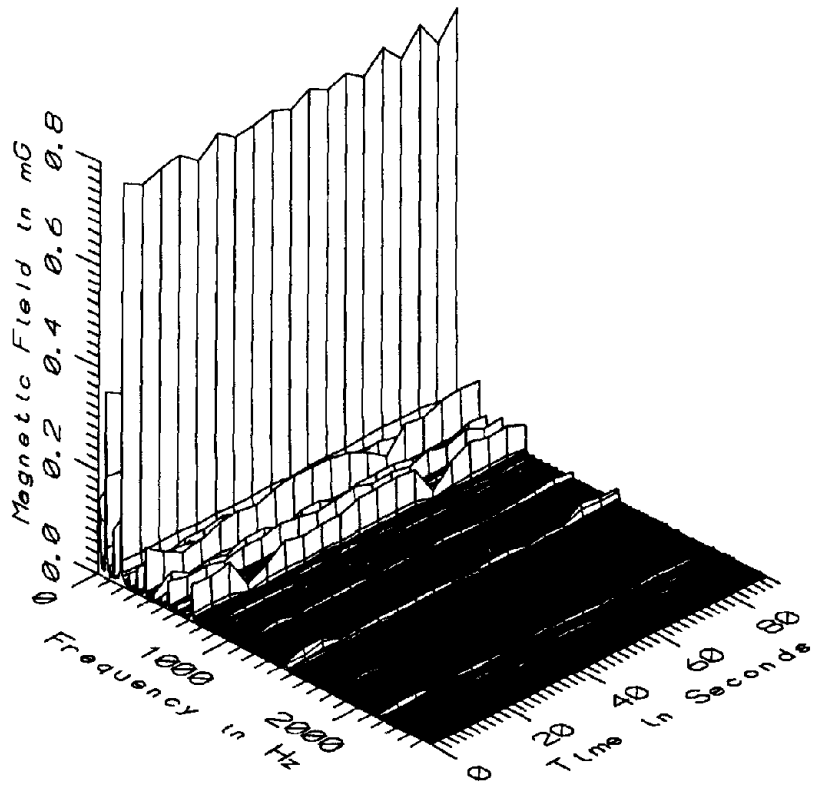

MET047 - 160cm FROM DISPATCHER'S MONITORS, 1.25M ABOVE FLOOR

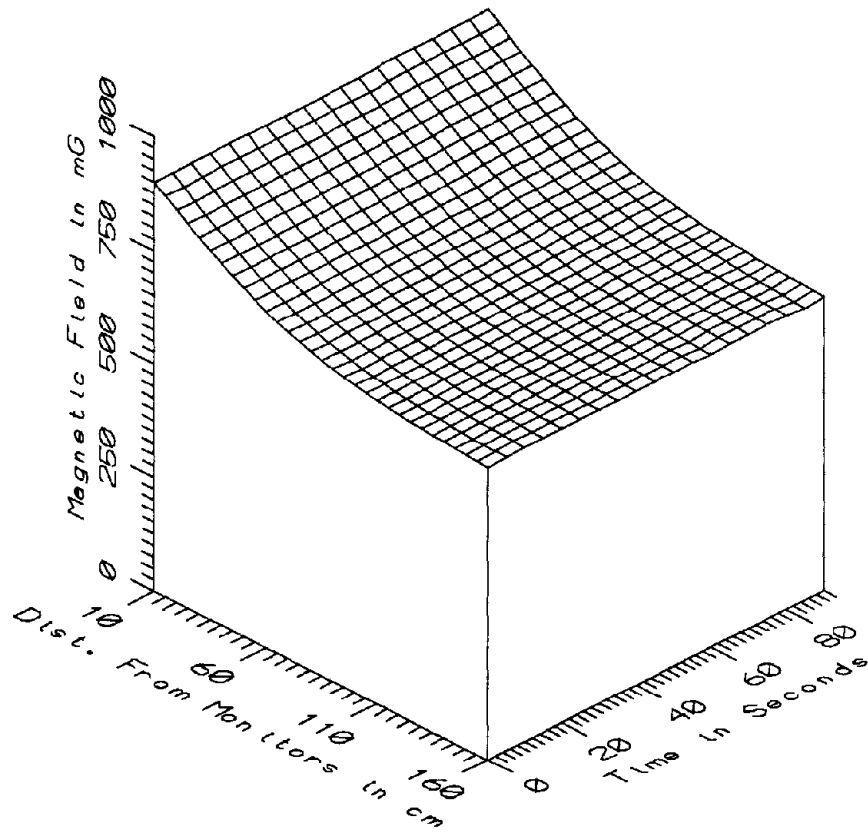

MET047 - IN DISPATCHER'S ROOM, 1.25M ABOVE FLOOR - STATIC

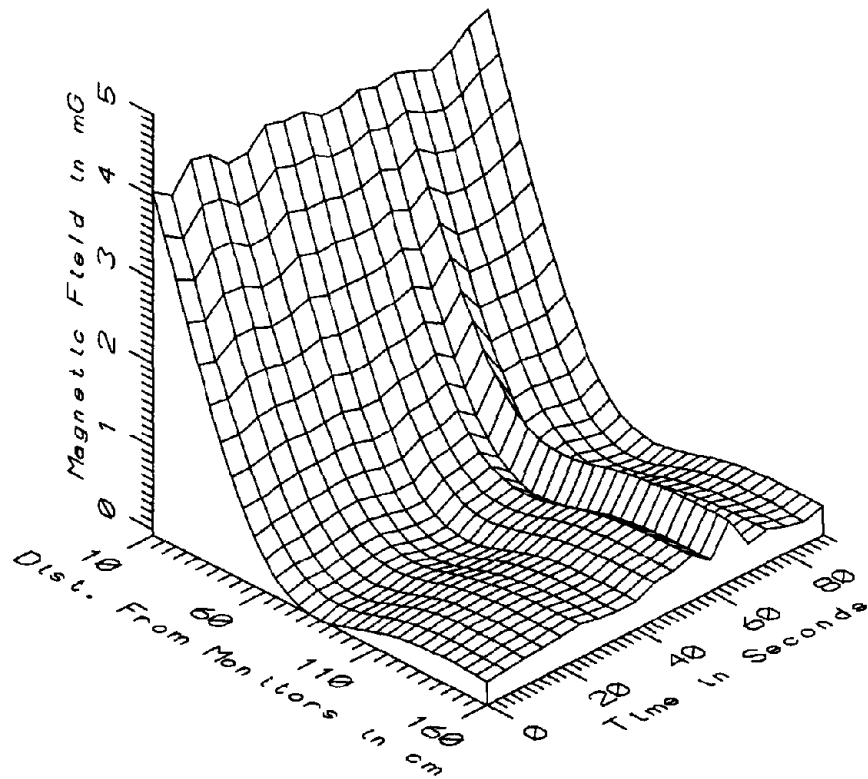

MET047 - IN DISPATCHER'S ROOM, 1.25M ABOVE FLOOR - LOW FREQ, 5-45Hz



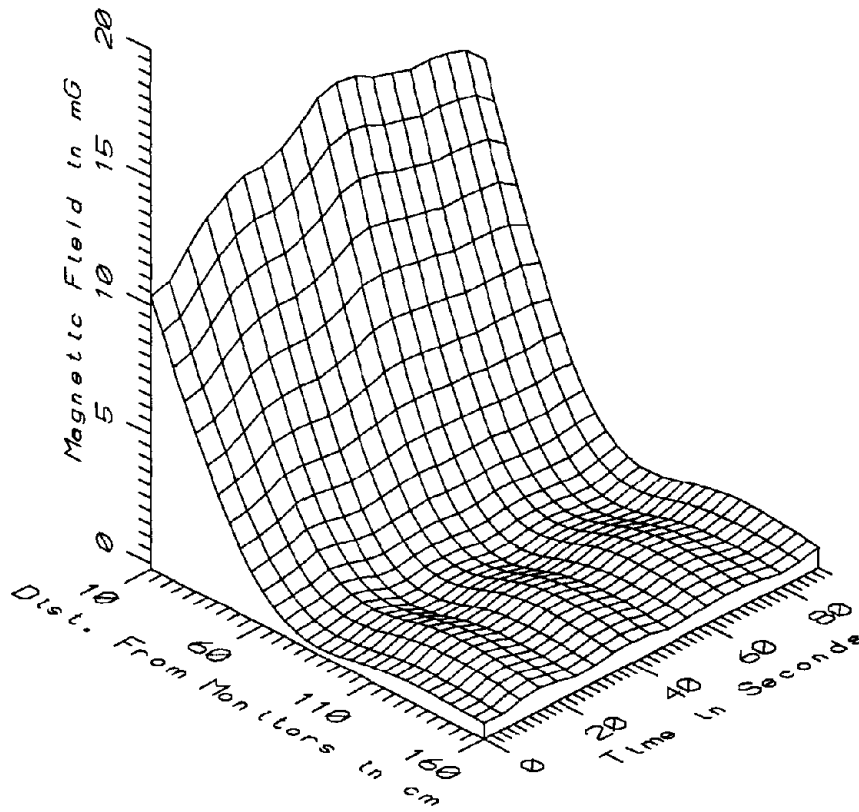

MET047 - IN DISPATCHER'S ROOM, 1.25M ABOVE FLOOR - POWER FREQ, 50-60Hz

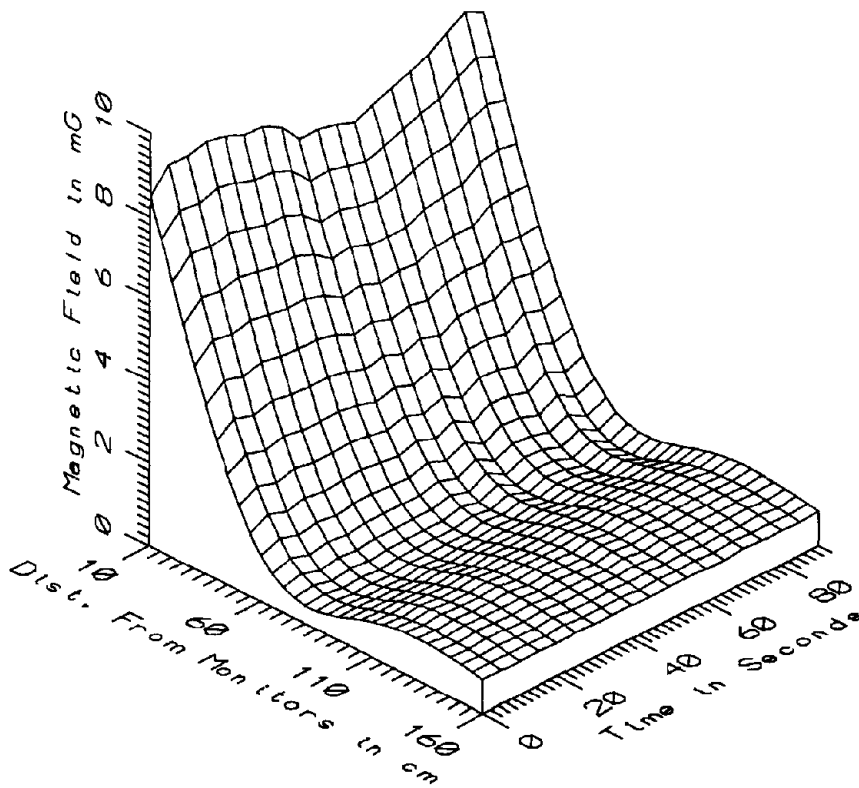

MET047 - IN DISPATCHER'S ROOM, 1.25M ABOVE FLOOR - POWER HARM, 65-300Hz

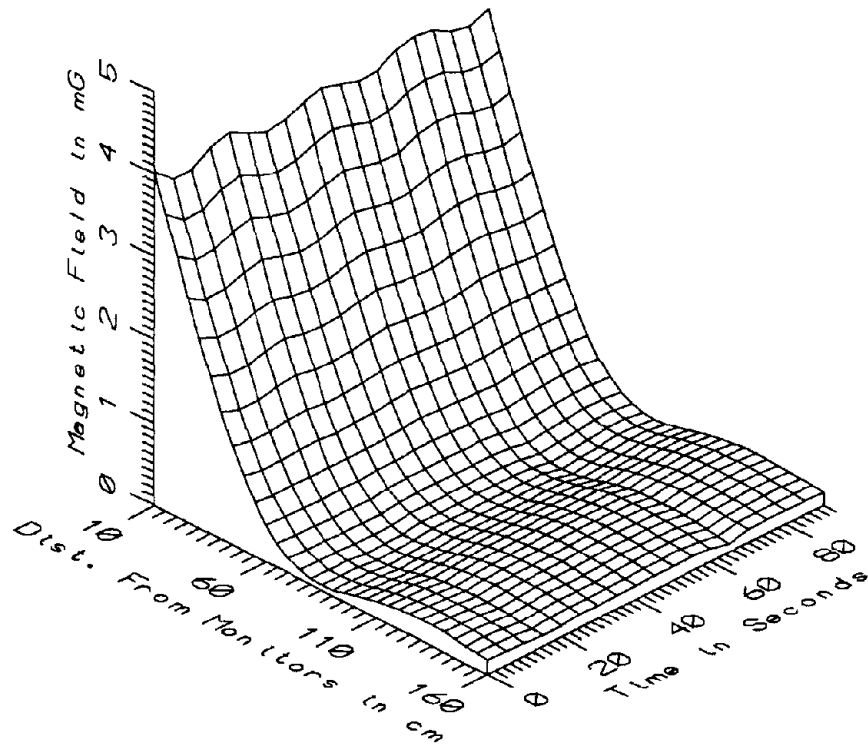

MET047 - IN DISPATCHER'S ROOM, 1.25M ABOVE FLOOR - HIGH FREQ, 305-2560Hz

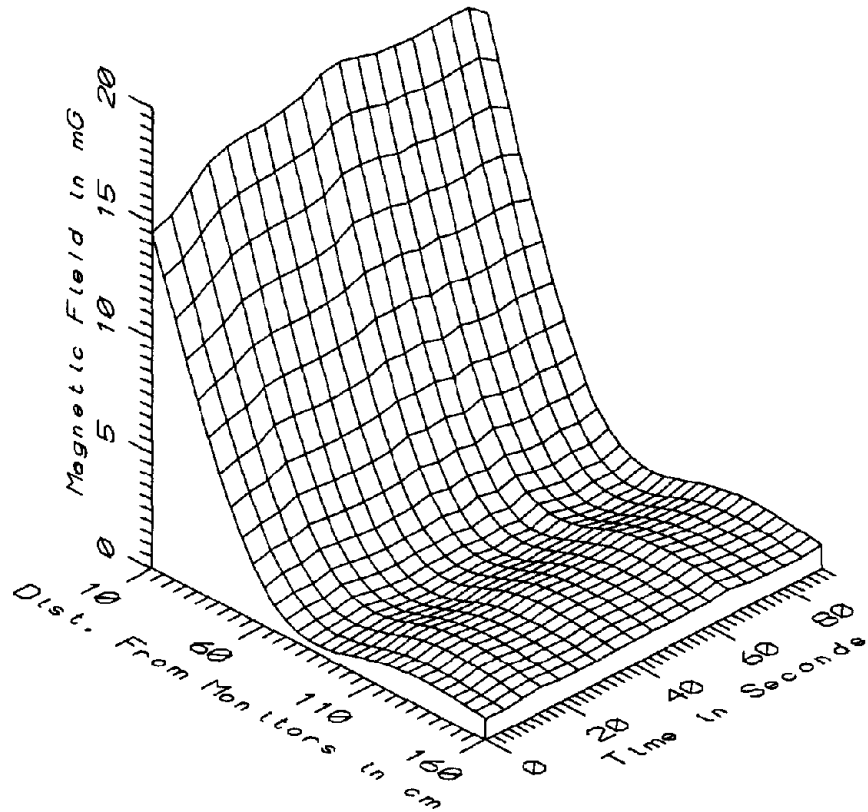

MET047 - IN DISPATCHER'S ROOM, 1.25M ABOVE FLOOR - ALL FREQ, 5-2560Hz

MET047 - IN DISPATCHER'S ROOM, FROM MONITORS		TOTAL OF 19 SAMPLES				
FREQUENCY BAND	DIST FROM VDT (cm)	MINIMUM MAGNETIC FIELD (mG)	MAXIMUM MAGNETIC FIELD (mG)	AVERAGE MAGNETIC FIELD (mG)	STANDARD DEVIATION (mG)	COEFFICIENT OF VARIATION (%)
STATIC	10	897.84	908.63	902.55	3.11	0.34
	60	738.00	742.75	740.12	1.62	0.22
	110	664.29	669.23	666.57	1.40	0.21
	160	641.62	647.56	645.00	1.52	0.24
5-45Hz	10	3.84	4.22	4.04	0.11	2.84
LOW FREQ	60	0.31	0.82	0.43	0.12	26.52
	110	0.12	0.60	0.22	0.11	48.47
	160	0.21	0.67	0.32	0.11	33.59
50-60Hz	10	10.32	15.07	13.38	1.38	10.29
PWR FREQ	60	1.09	1.56	1.31	0.11	8.77
	110	0.21	0.78	0.50	0.17	34.33
	160	0.33	0.63	0.45	0.09	20.87
65-300Hz	10	7.75	9.12	8.53	0.45	5.26
PWR HARM	60	1.09	1.37	1.23	0.09	7.22
	110	0.81	0.91	0.86	0.03	3.09
	160	0.79	0.84	0.82	0.02	1.86
305-2560Hz	10	3.82	4.09	3.95	0.09	2.17
HIGH FREQ	60	0.38	0.45	0.42	0.02	4.01
	110	0.13	0.20	0.17	0.02	11.40
	160	0.09	0.16	0.14	0.02	12.86
5-2560Hz	10	14.53	17.92	16.88	0.93	5.53
ALL FREQ	60	1.66	2.11	1.90	0.12	6.15
	110	0.93	1.25	1.05	0.09	9.03
	160	0.92	1.18	1.01	0.06	6.19



APPENDIX AR

DATASET MET048  
SHADY GROVE DISPATCHER'S ROOM, FROM MOCK-UP PANEL

Measurement Setup Code:           Staff:     54   Reference:  -  
  Drawing:  A-8

Vehicle Status:                    NA

Measurement Date:                 May 20, 1992

Measurement Time:                 Start:     11:15:21  
  End:       11:16:46

Number of Samples:                18

Programmed Sample Interval:      5 sec

Actual Sample Interval:          5.0 sec

Frequency Spectrum Parameters

<u>Probe Type:</u>	<u>Wideband</u>	<u>Static</u>
Maximum Frequency (Hz)	2560	100
Minimum Frequency (Hz)	5	0
Spectral Bandwidth (Hz)	5	1

Missing Data: No reference probe

Saturated Data: None

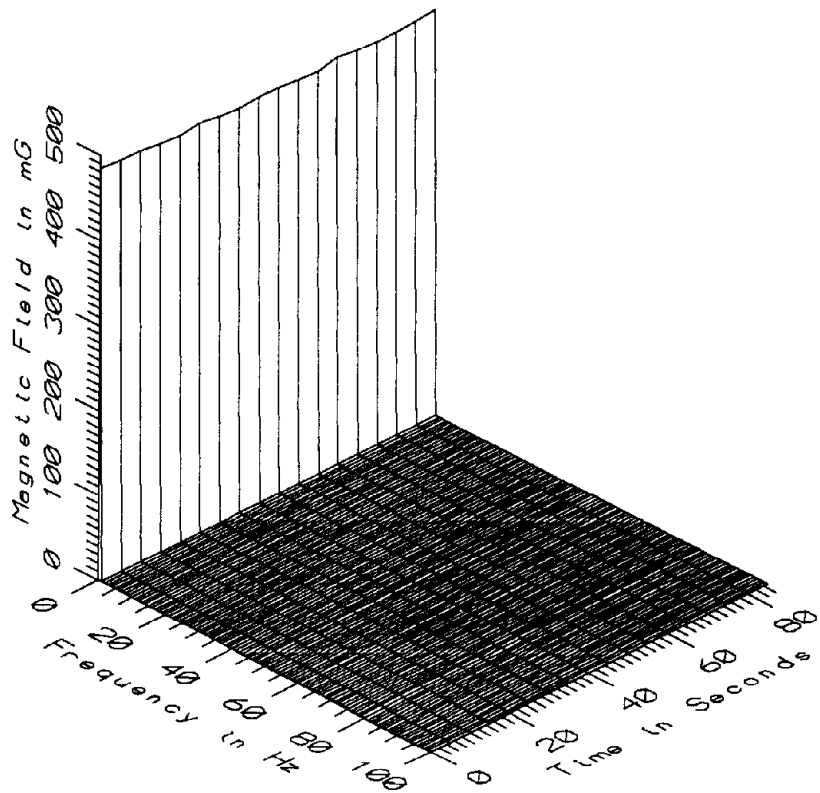

MET048 - 10cm FROM DISPATCHER'S MOCK-UP PANEL, 1.25M ABOVE FLOOR

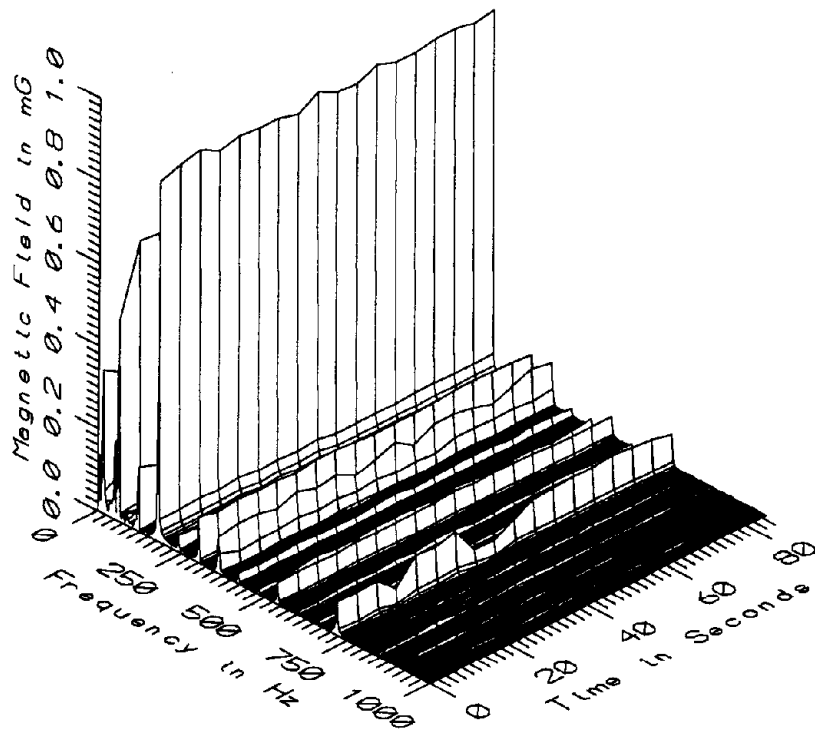

MET048 - 10cm FROM DISPATCHER'S MOCK-UP PANEL, 1.25M ABOVE FLOOR

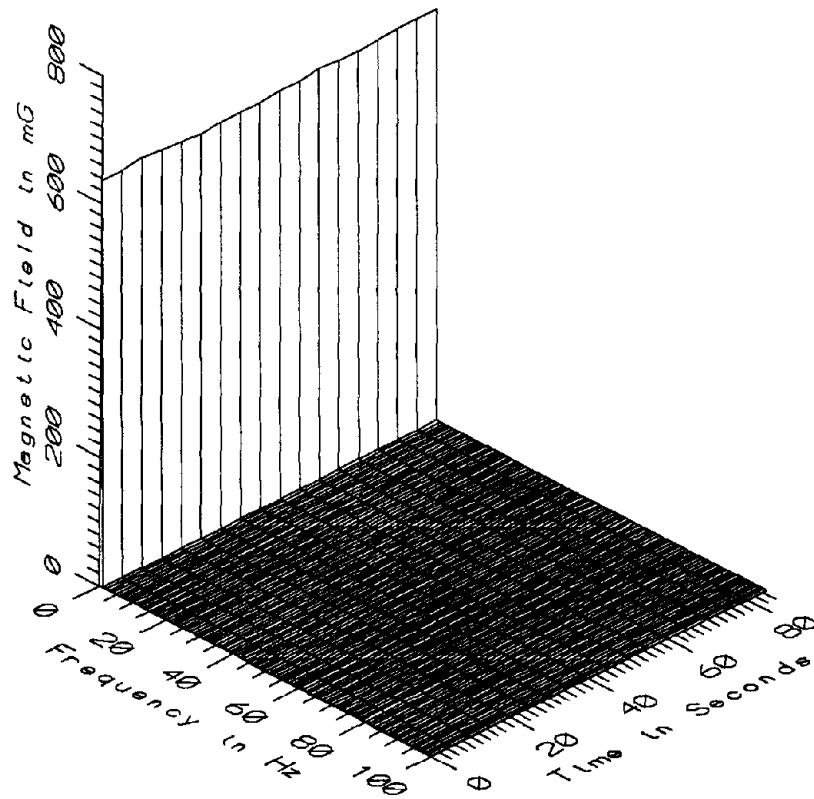

MET048 - 60cm FROM DISPATCHER'S MOCK-UP PANEL, 1.25M ABOVE FLOOR

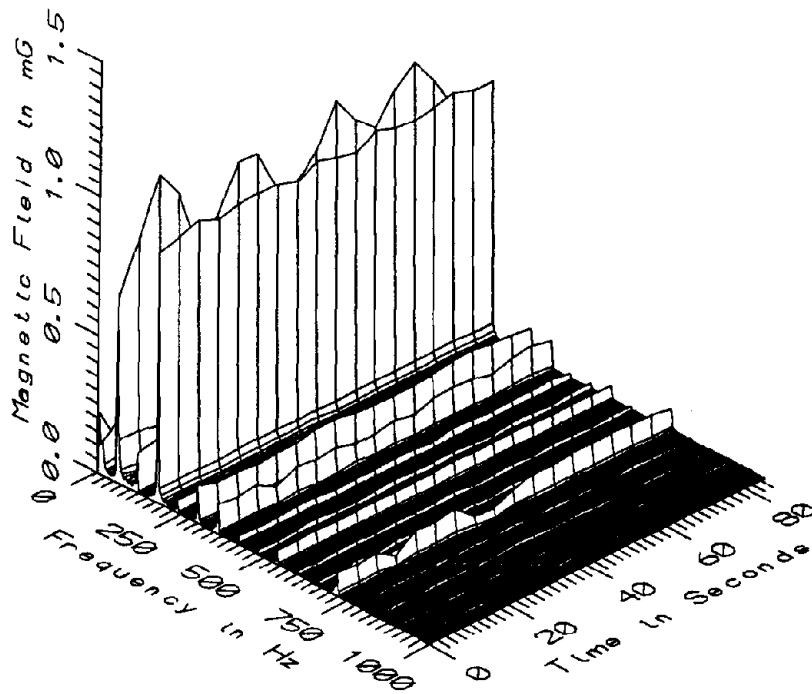

MET048 - 60cm FROM DISPATCHER'S MOCK-UP PANEL, 1.25M ABOVE FLOOR

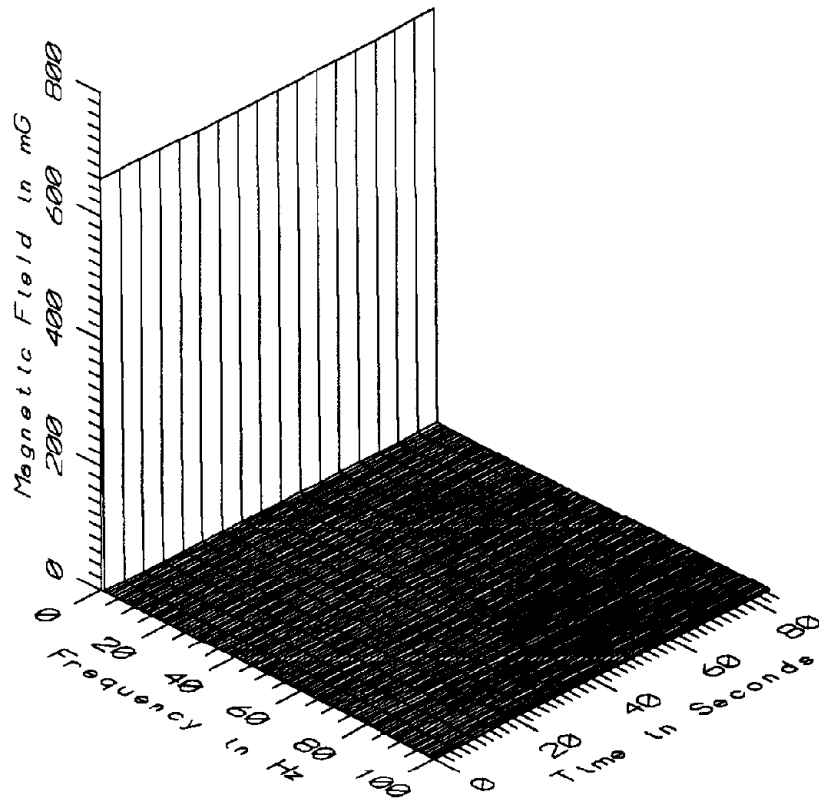

MET048 - 110cm FROM DISPATCHER'S MOCK-UP PANEL, 1.25M ABOVE FLOOR

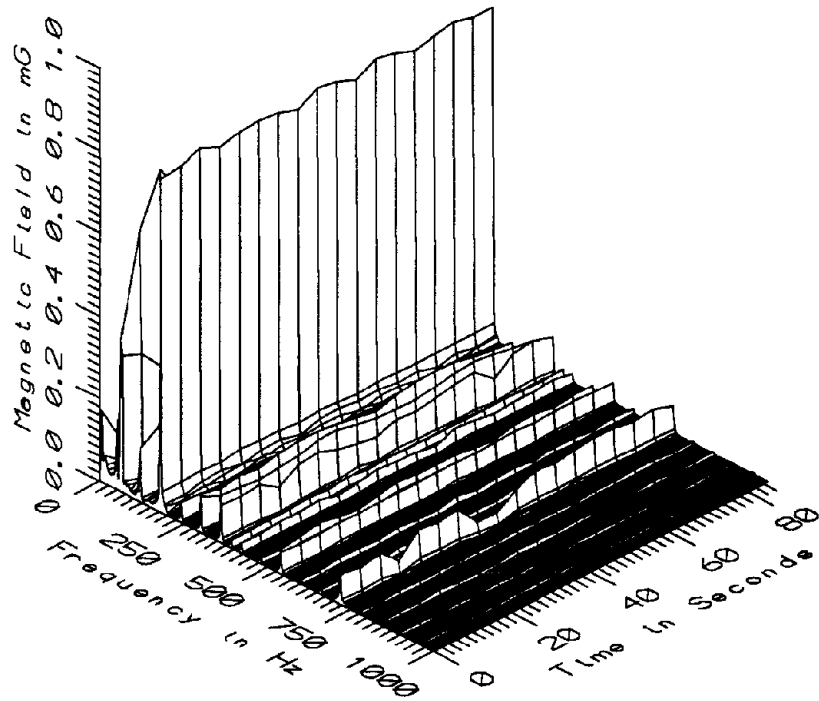

MET048 - 110cm FROM DISPATCHER'S MOCK-UP PANEL, 1.25M ABOVE FLOOR



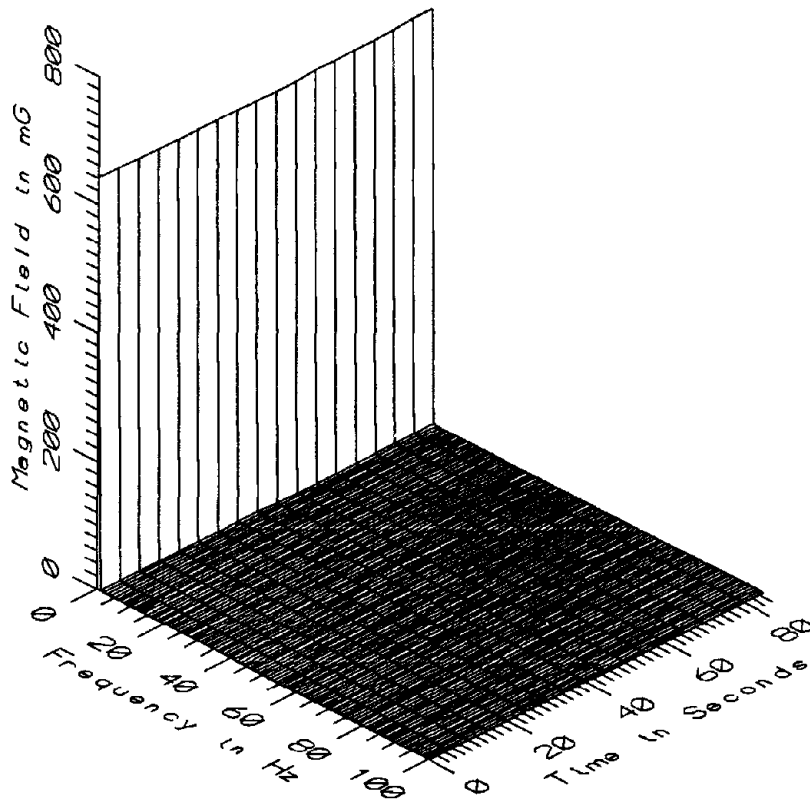

MET048 - 160cm FROM DISPATCHER'S MOCK-UP PANEL, 1.25M ABOVE FLOOR

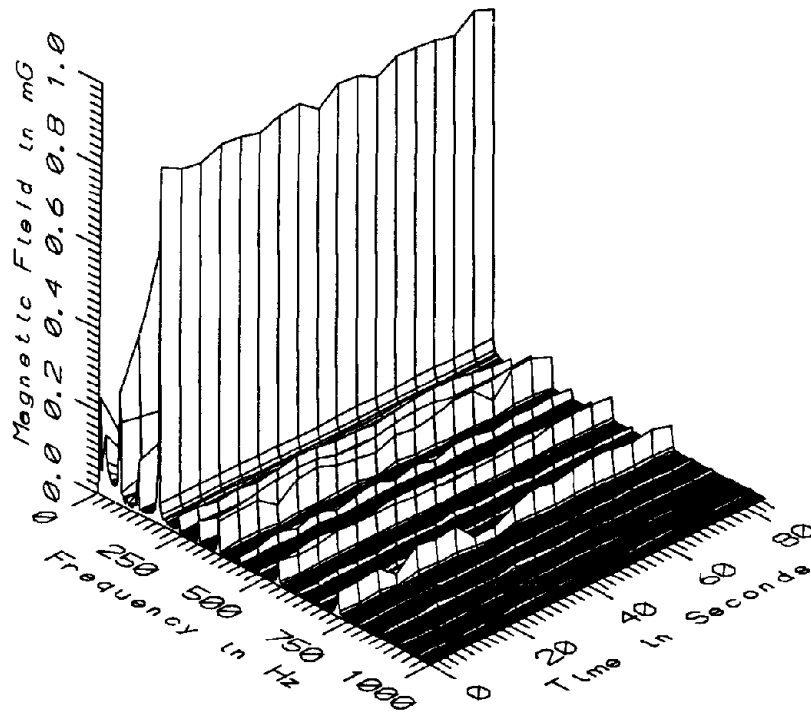

MET048 - 160cm FROM DISPATCHER'S MOCK-UP PANEL, 1.25M ABOVE FLOOR

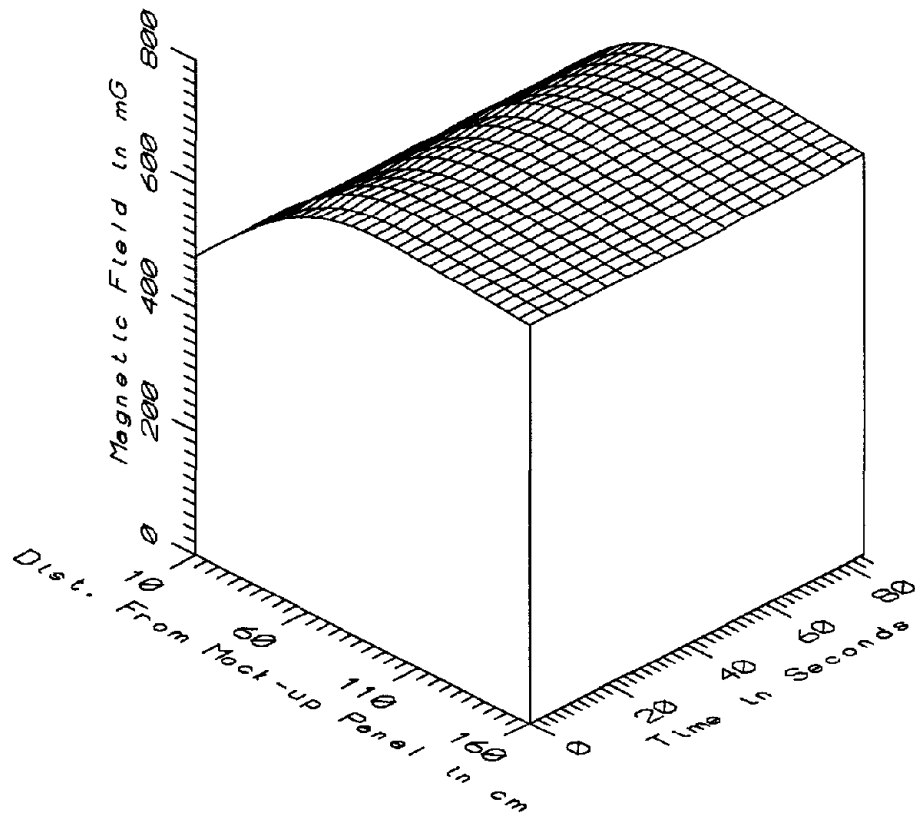

MET048 - IN DISPATCHER'S ROOM, 1.25M ABOVE FLOOR - STATIC

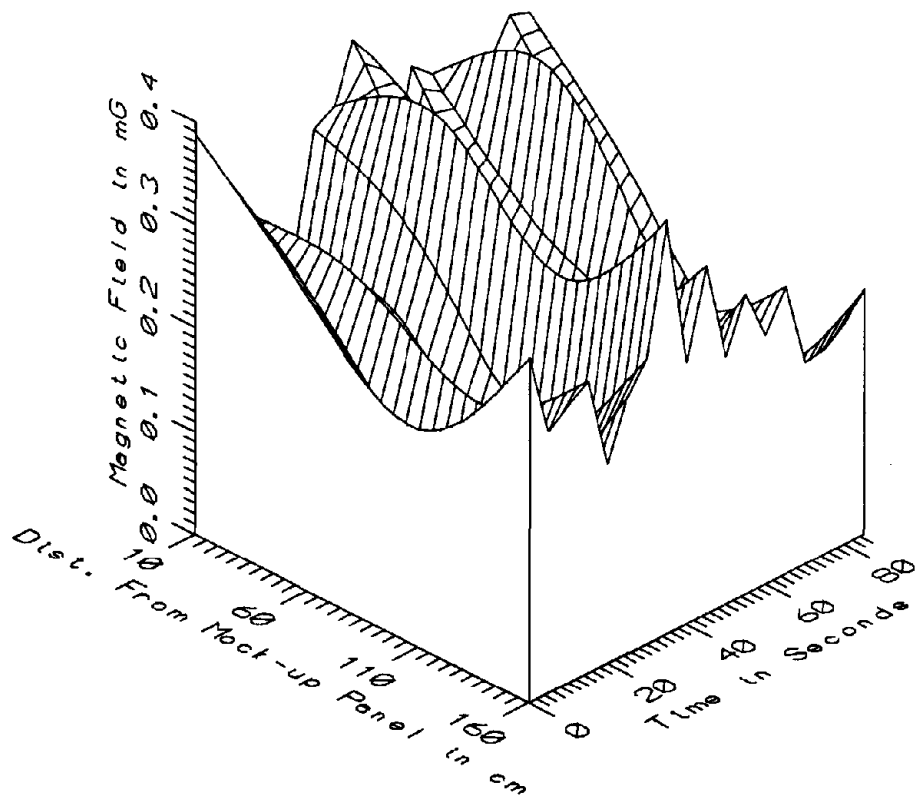

MET048 - IN DISPATCHER'S ROOM, 1.25M ABOVE FLOOR - LOW FREQ, 5-45Hz

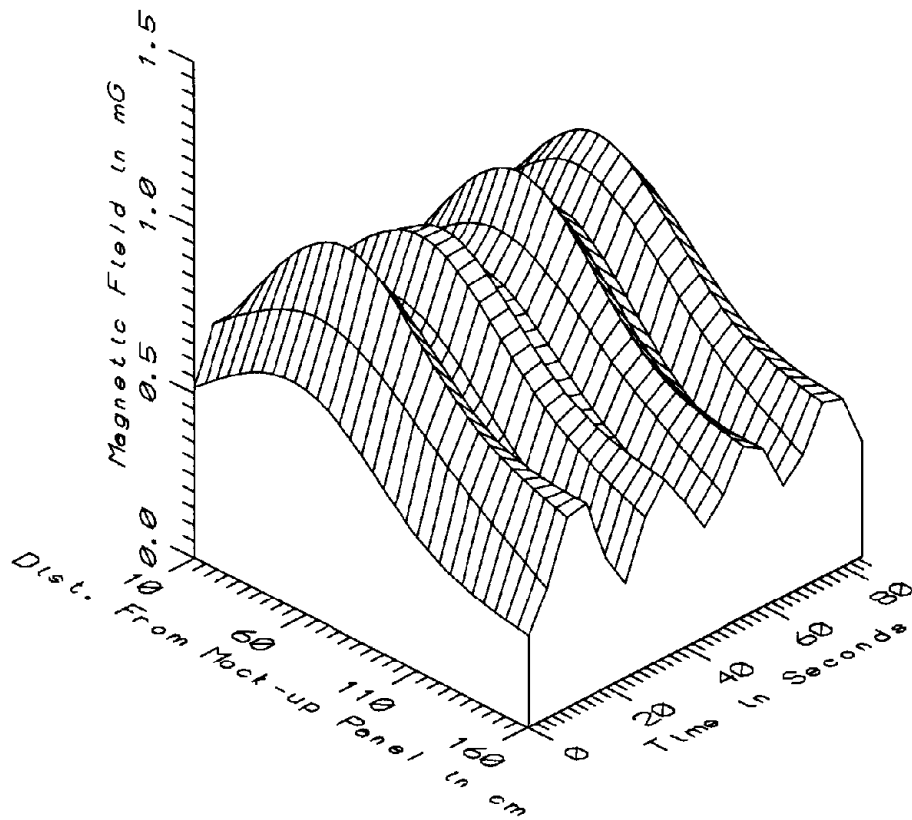

MET048 - IN DISPATCHER'S ROOM, 1.25M ABOVE FLOOR - POWER FREQ, 50-60Hz

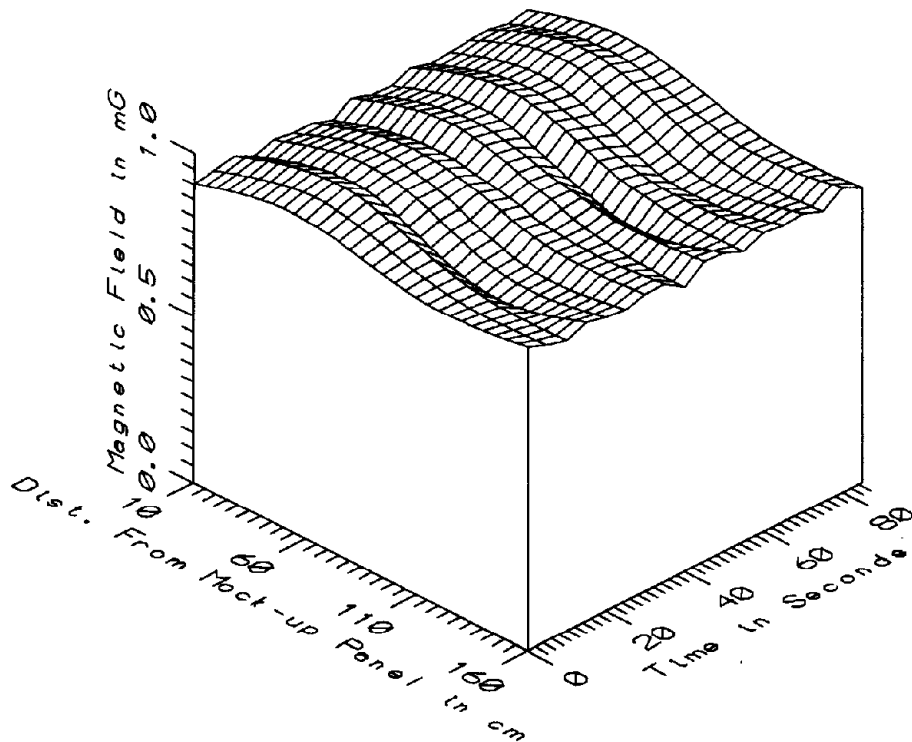

MET048 - IN DISPATCHER'S ROOM, 1.25M ABOVE FLOOR - POWER HARM, 65-300Hz

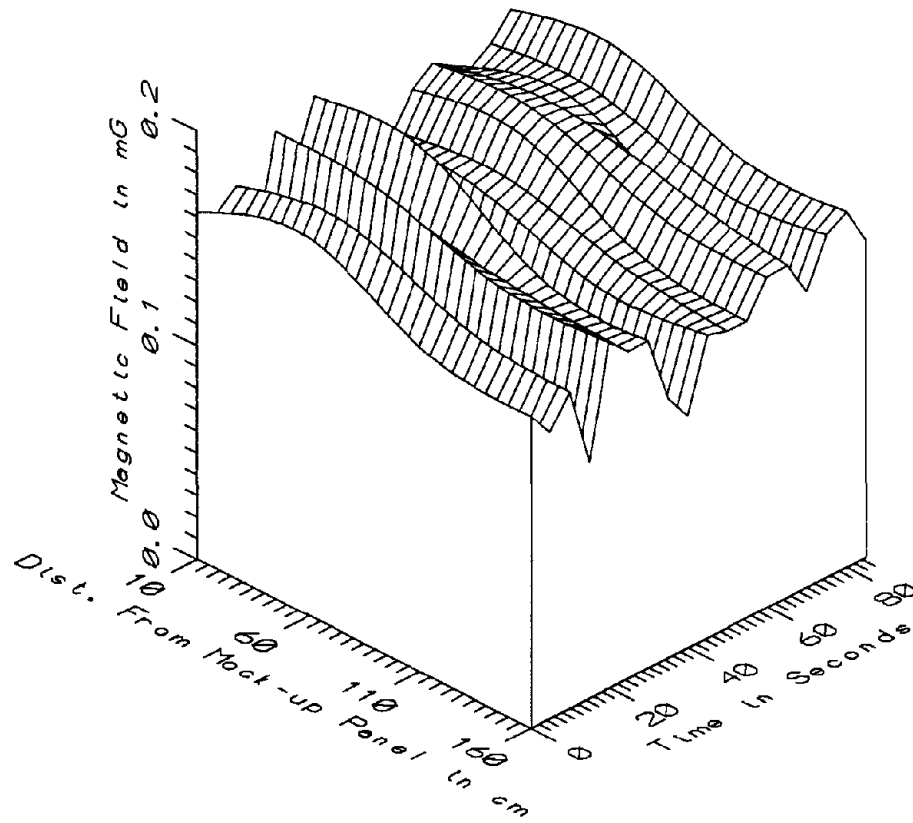

MET048 - IN DISPATCHER'S ROOM, 1.25M ABOVE FLOOR - HIGH FREQ, 305-2560Hz

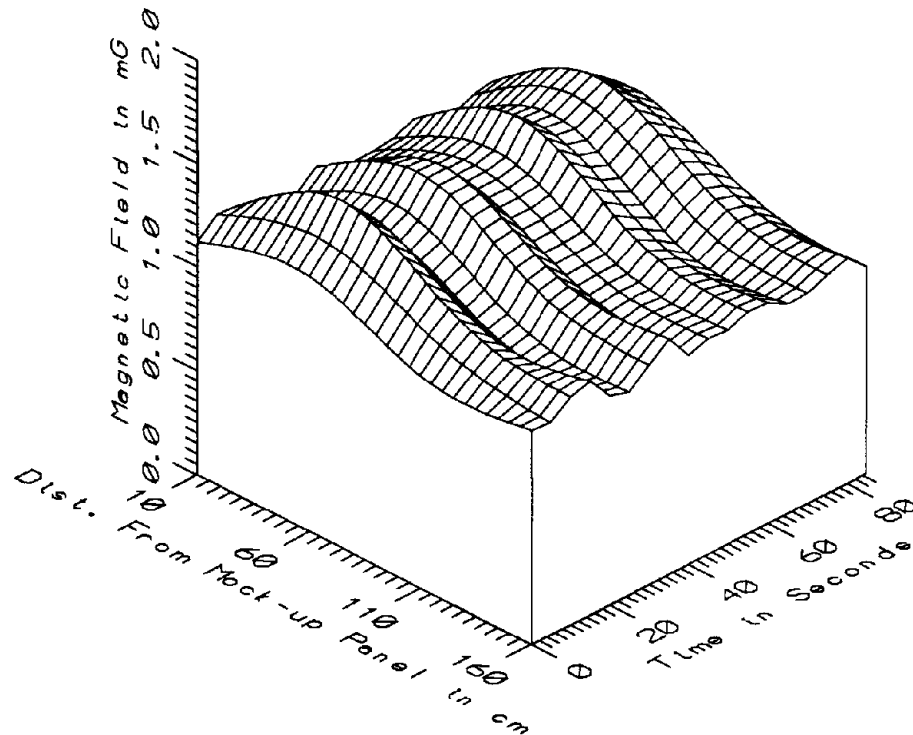

MET048 - IN DISPATCHER'S ROOM, 1.25M ABOVE FLOOR - ALL FREQ, 5-2560Hz

MET048 - IN DISPATCHER'S ROOM, FROM MOCK-UP PANEL		TOTAL OF 18 SAMPLES				
FREQUENCY BAND	DIST FROM PANEL (cm)	MINIMUM MAGNETIC FIELD (mG)	MAXIMUM MAGNETIC FIELD (mG)	AVERAGE MAGNETIC FIELD (mG)	STANDARD DEVIATION (mG)	COEFFICIENT OF VARIATION (%)
STATIC	10	472.87	484.39	477.36	3.53	0.74
	60	632.81	644.55	639.02	3.38	0.53
	110	657.27	662.33	659.47	1.28	0.19
	160	639.81	645.17	641.71	1.46	0.23
5-45Hz	10	0.22	0.40	0.32	0.06	17.48
LOW FREQ	60	0.19	0.39	0.25	0.06	22.22
	110	0.08	0.29	0.16	0.06	37.00
	160	0.20	0.40	0.26	0.05	20.33
50-60Hz	10	0.46	0.68	0.57	0.07	12.44
PWR FREQ	60	0.68	1.05	0.87	0.10	11.89
	110	0.40	0.75	0.59	0.09	15.96
	160	0.28	0.58	0.43	0.10	22.19
65-300Hz	10	0.89	0.93	0.91	0.01	1.14
PWR HARM	60	0.96	1.01	0.98	0.01	1.48
	110	0.84	0.90	0.88	0.02	2.33
	160	0.86	0.92	0.89	0.02	1.77
305-2560Hz	10	0.12	0.19	0.16	0.02	10.57
HIGH FREQ	60	0.12	0.19	0.16	0.02	11.82
	110	0.11	0.17	0.15	0.02	11.56
	160	0.11	0.17	0.14	0.02	11.52
5-2560Hz	10	1.07	1.21	1.14	0.04	3.38
ALL FREQ	60	1.22	1.47	1.35	0.07	5.22
	110	1.00	1.19	1.09	0.05	4.86
	160	0.97	1.12	1.04	0.04	4.15



APPENDIX AS

DATASET MET049  
CENTER OF AISLE, CENTER OF A 3000 SERIES CAR

Measurement Setup Code:        Staff:     1     Reference:   -  
   Drawing:  A-1

Vehicle Status:                Traveling on the Red Line

Measurement Date:              May 20, 1992

Measurement Time:              Start:     12:04:30  
   End:       12:07:15

Number of Samples:             34

Programmed Sample Interval:    5 sec

Actual Sample Interval:        5.0 sec

Frequency Spectrum Parameters

<u>Probe Type:</u>	<u>Wideband</u>	<u>Static</u>
Maximum Frequency (Hz)	2560	NA
Minimum Frequency (Hz)	5	NA
Spectral Bandwidth (Hz)	5	NA

Missing Data: No reference probe

Saturated Data: None

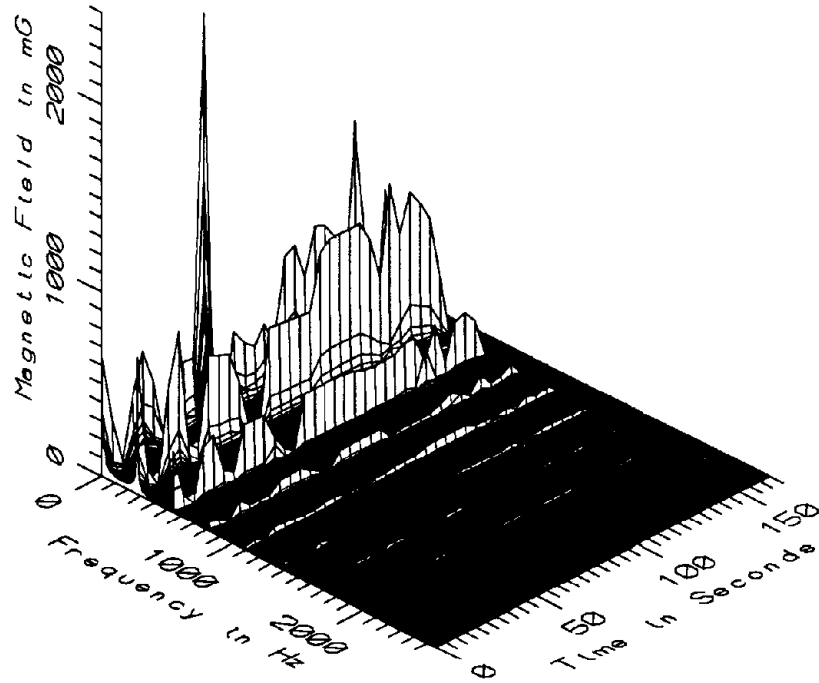

MET049 - 10cm ABOVE FLOOR, CENTER OF AISLE, CENTER OF CAR 3XXX

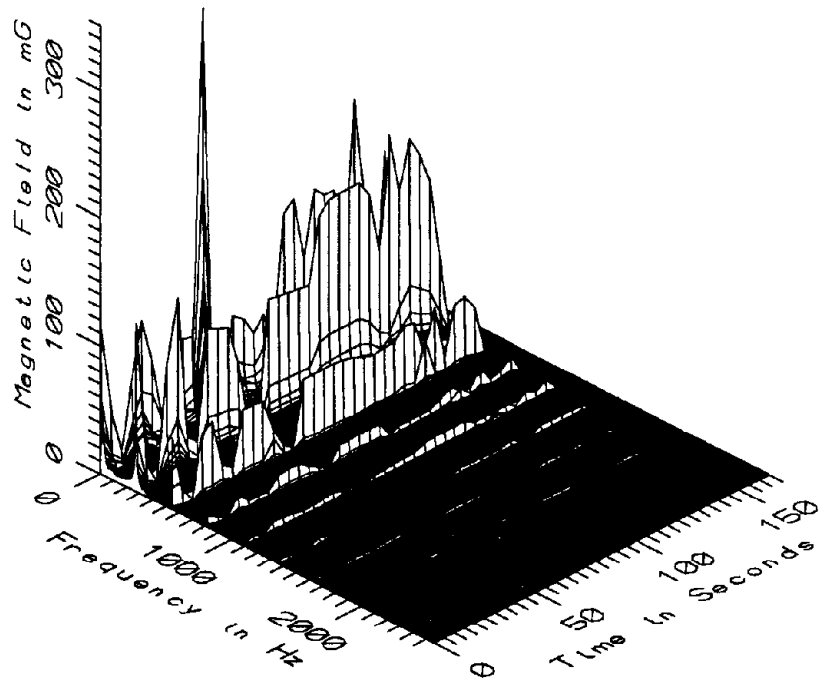

MET049 - 60cm ABOVE FLOOR, CENTER OF AISLE, CENTER OF CAR 3XXX



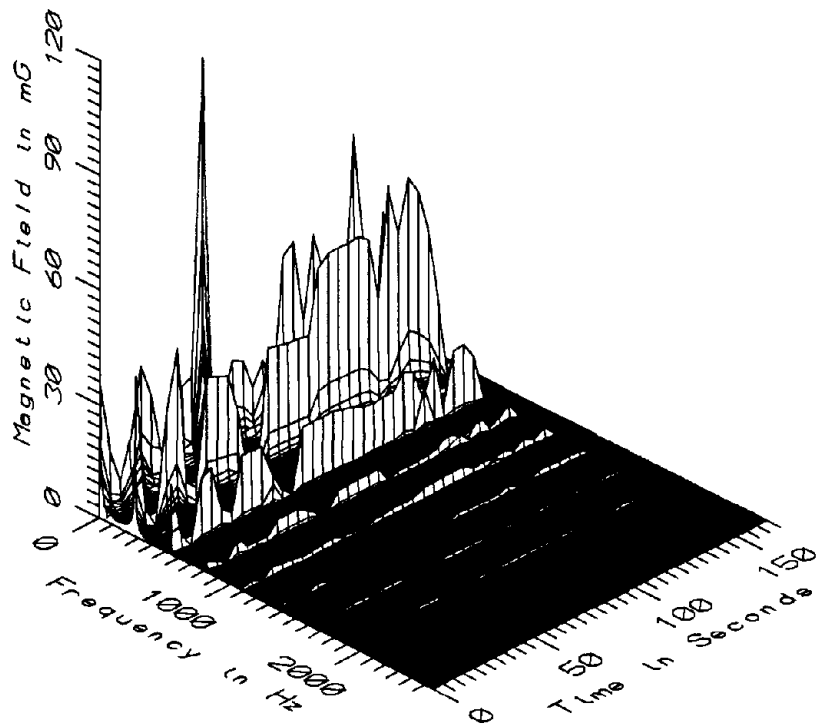

MET049 - 110cm ABOVE FLOOR, CENTER OF AISLE, CENTER OF CAR 3XXX

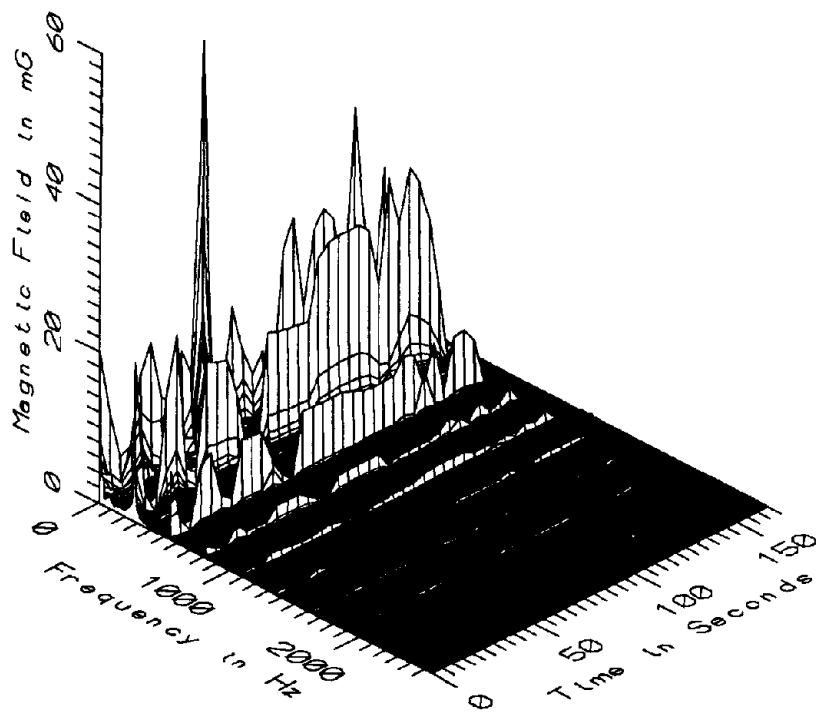

MET049 - 160cm ABOVE FLOOR, CENTER OF AISLE, CENTER OF CAR 3XXX

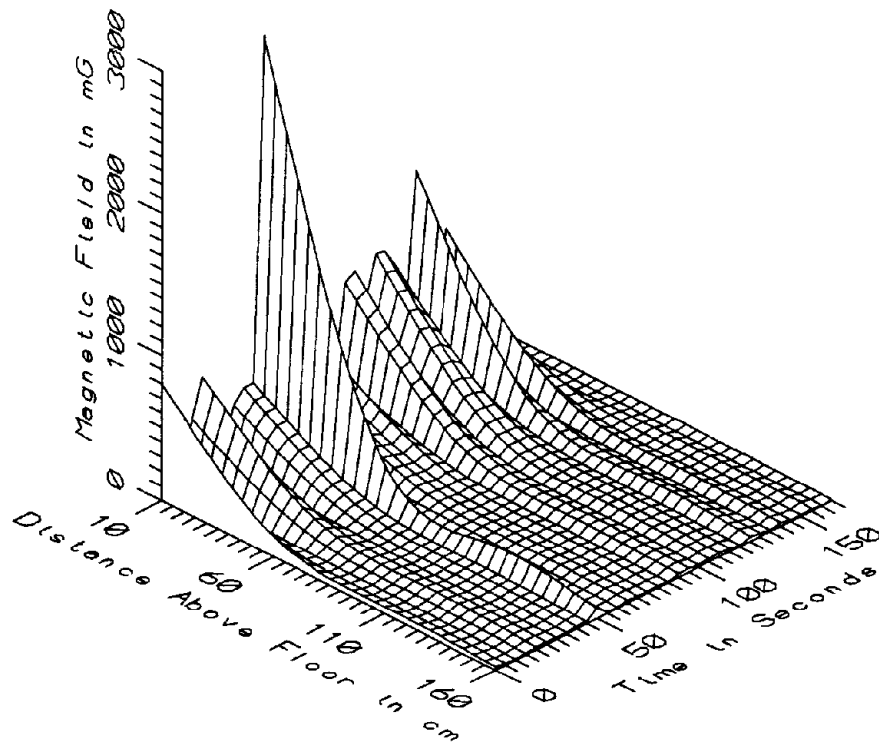

MET049 - CENTER OF AISLE, CENTER OF CAR 3XXX - LOW FREQ, 5-45Hz

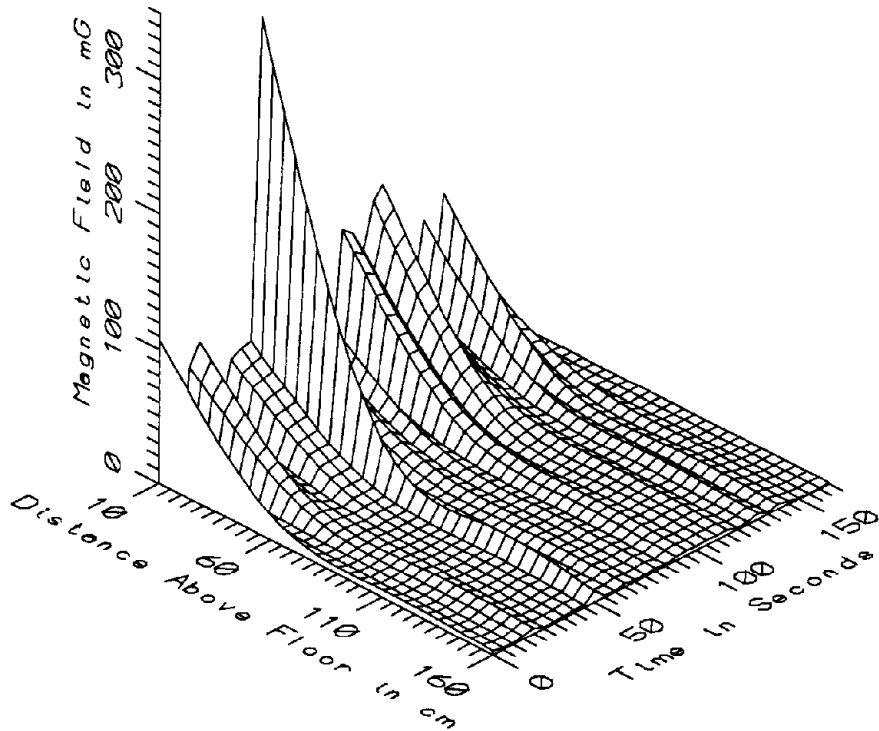

MET049 - CENTER OF AISLE, CENTER OF CAR 3XXX - POWER FREQ, 50-60Hz

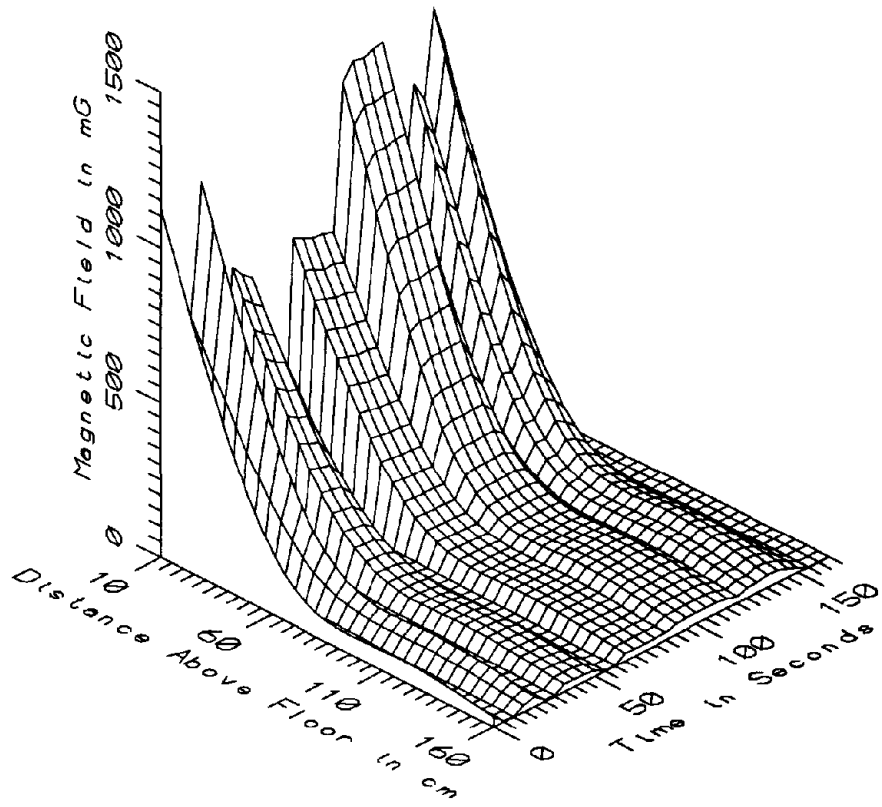

MET049 - CENTER OF AISLE, CENTER OF CAR 3XXX - POWER HARM, 65-300Hz

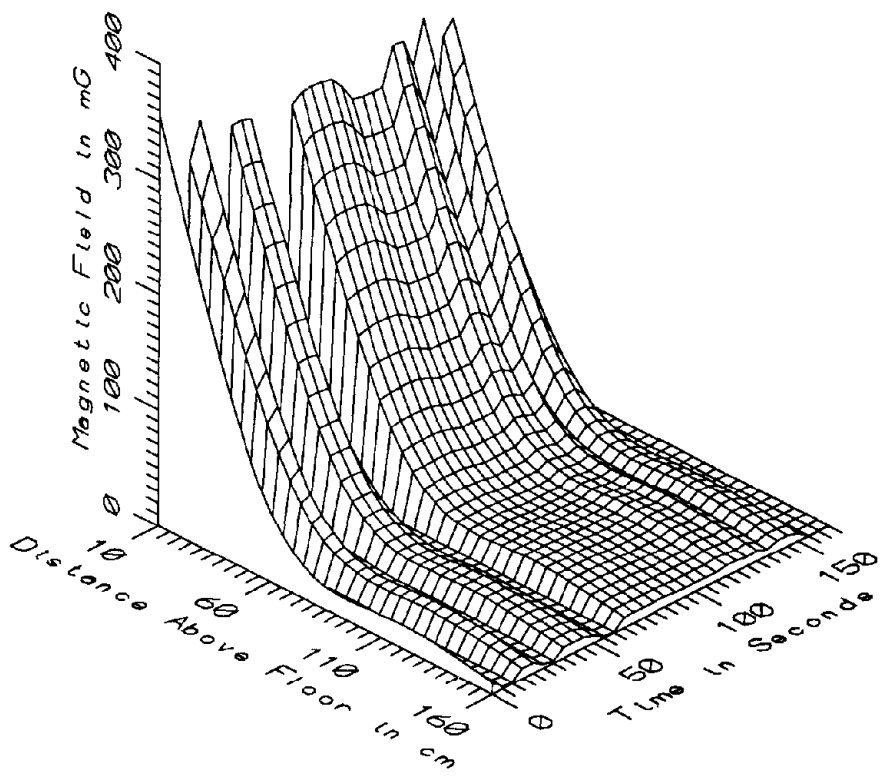

MET049 - CENTER OF AISLE, CENTER OF CAR 3XXX - HIGH FREQ, 305-2560Hz

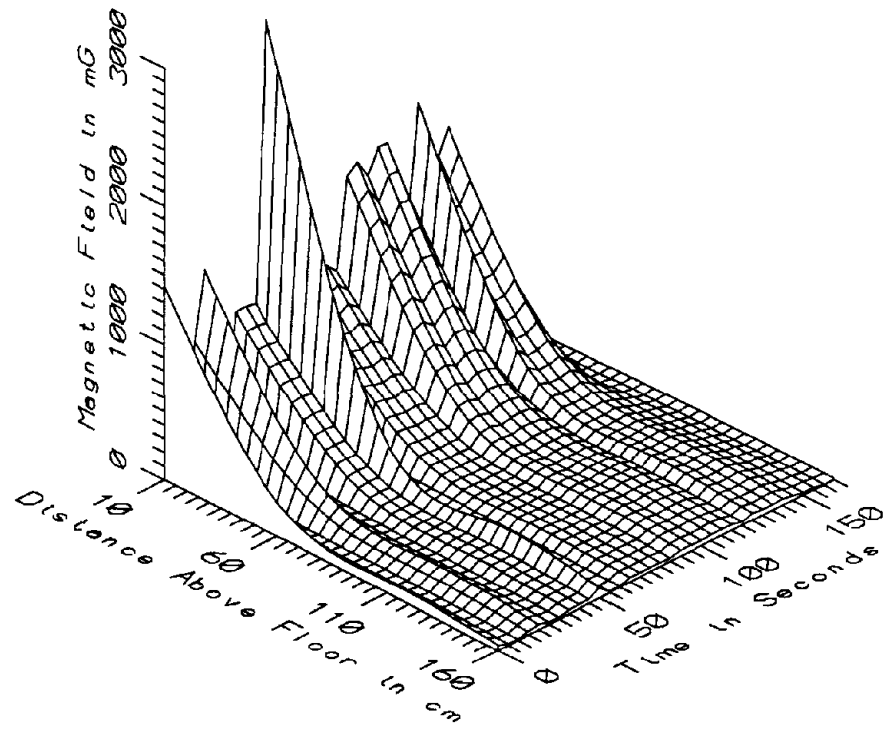

MET049 - CENTER OF AISLE, CENTER OF CAR 3XXX - ALL FREQ, 5-2560Hz

MET049 - CENTER OF AISLE, CENTER OF CAR 3XXX		TOTAL OF 34 SAMPLES				
FREQUENCY BAND	HEIGHT ABOVE FLOOR (cm)	MINIMUM MAGNETIC FIELD (mG)	MAXIMUM MAGNETIC FIELD (mG)	AVERAGE MAGNETIC FIELD (mG)	STANDARD DEVIATION (mG)	COEFFICIENT OF VARIATION (%)
5-45Hz LOW FREQ	10	6.10	2892.17	562.16	532.03	94.64
	60	4.76	423.92	98.53	80.03	81.23
	110	4.06	139.46	33.88	24.93	73.58
	160	5.70	71.44	18.56	12.52	67.47
50-60Hz PWR FREQ	10	1.23	309.21	70.29	56.62	80.54
	60	1.05	50.82	12.59	9.18	72.90
	110	0.91	16.27	4.37	2.93	66.96
	160	0.66	8.32	2.35	1.57	66.88
65-300Hz PWR HARM	10	1.36	1326.18	738.81	456.98	61.85
	60	1.53	248.63	133.47	81.88	61.35
	110	1.51	86.06	44.17	26.89	60.88
	160	1.21	43.11	22.03	13.28	60.30
305-2560Hz HIGH FREQ	10	1.11	355.32	230.90	121.29	52.53
	60	1.06	61.60	41.19	21.28	51.68
	110	0.99	19.92	13.65	6.82	49.96
	160	0.77	9.91	6.84	3.32	48.56
5-2560Hz ALL FREQ	10	7.13	2986.99	997.97	657.03	65.84
	60	5.31	443.59	177.78	106.55	59.94
	110	4.55	145.92	60.23	32.66	54.23
	160	6.00	74.62	31.32	15.64	49.94

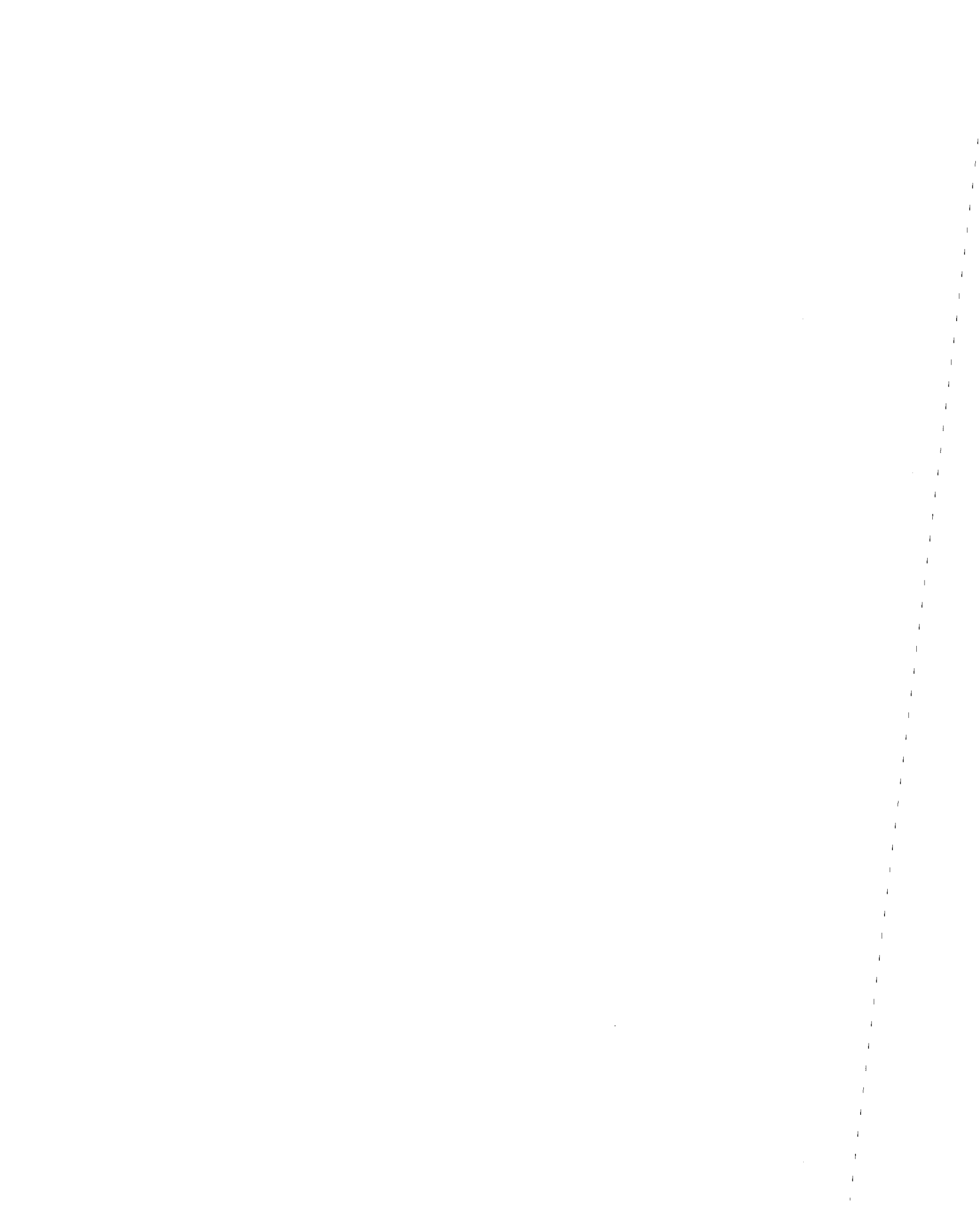

APPENDIX AT

DATASET MET050  
AXIAL PROFILE IN CENTER OF A 3000 SERIES CAR,  
FLOOR LEVEL

Measurement Setup Code:        Staff:    2     Reference: -  
   Drawing: A-1

Vehicle Status:                    Traveling on the Red Line

Measurement Date:                May 20, 1992

Measurement Time:                Start:     12:07:32  
   End:        12:08:20

Number of Samples:                11

Programmed Sample Interval:     5 sec

Actual Sample Interval:          4.8 sec

Frequency Spectrum Parameters

<u>Probe Type:</u>	<u>Wideband</u>	<u>Static</u>
Maximum Frequency (Hz)	2560	NA
Minimum Frequency (Hz)	5	NA
Spectral Bandwidth (Hz)	5	NA

Missing Data: No reference probe

Saturated Data: None

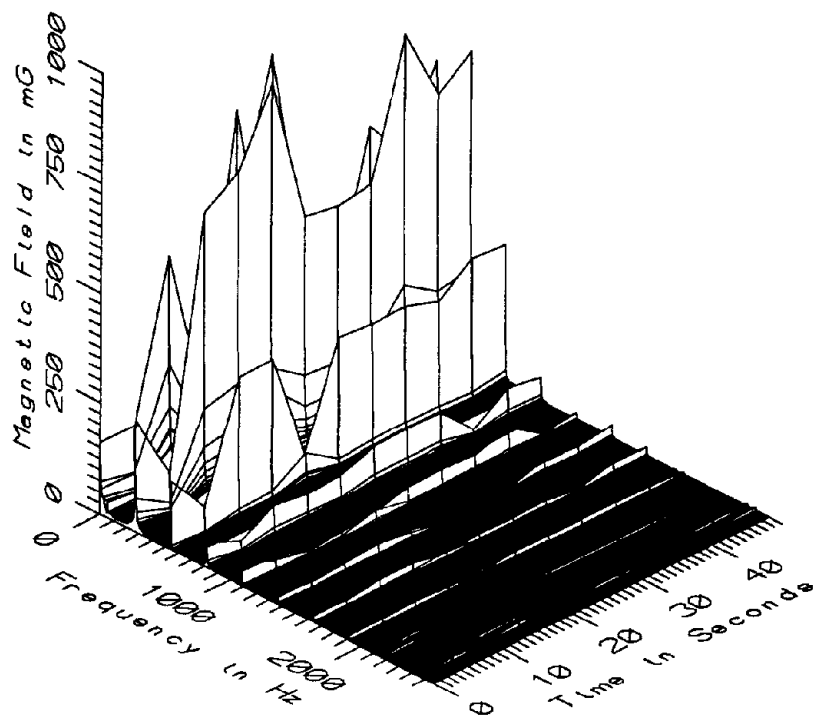

MET050 - -50cm FROM CENTER OF CAR 3XXX ALONG AXIS, FLOOR LEVEL

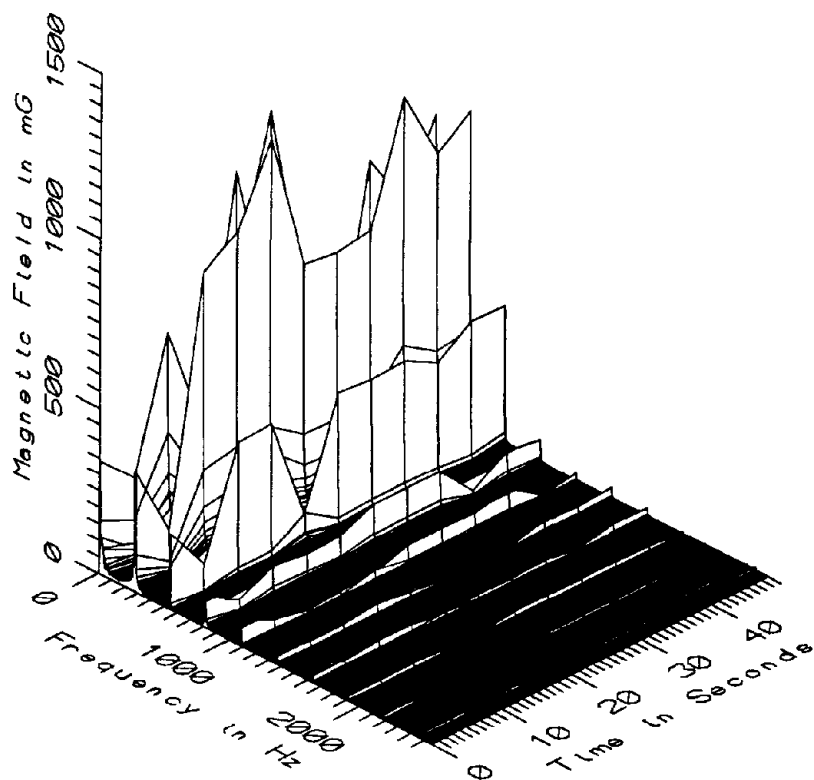

MET050 - 0cm FROM CENTER OF CAR 3XXX ALONG AXIS, FLOOR LEVEL



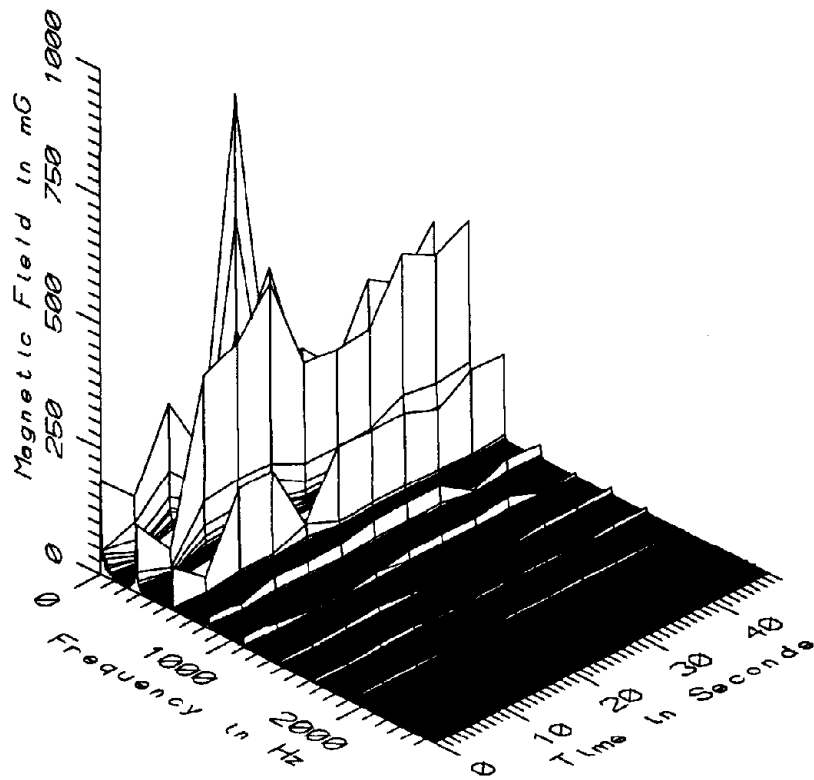

MET050 - 50cm FROM CENTER OF CAR 3XXX ALONG AXIS, FLOOR LEVEL

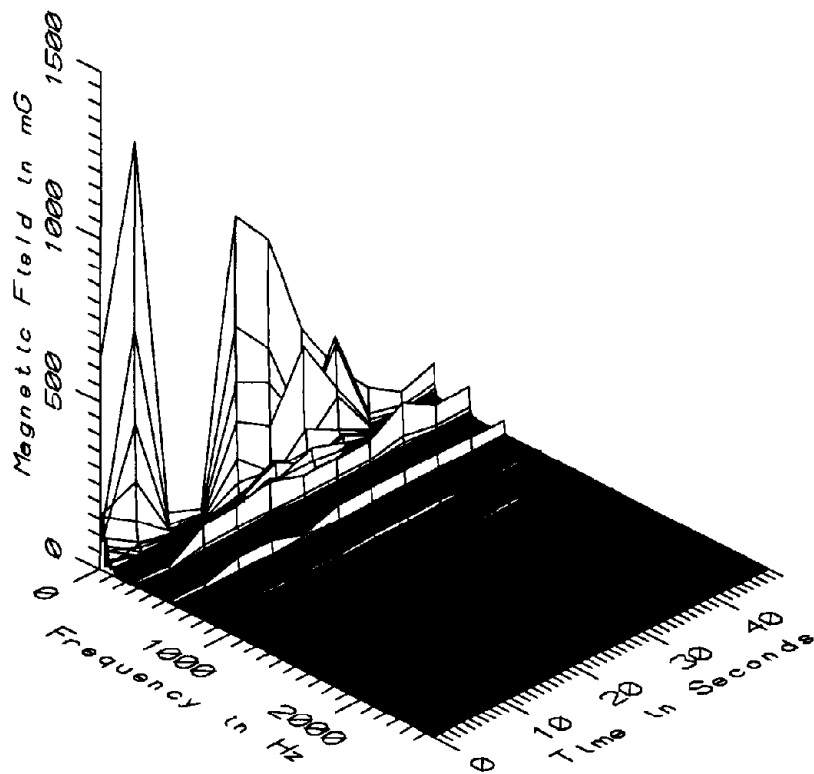

MET050 - 100cm FROM CENTER OF CAR 3XXX ALONG AXIS, FLOOR LEVEL

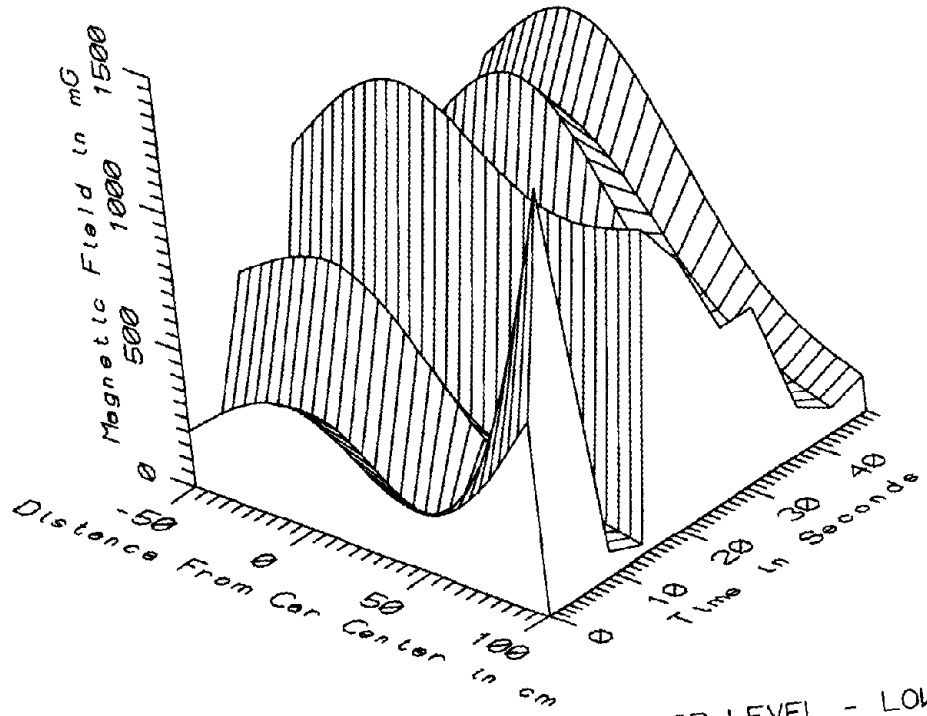

MET050 - AXIAL AT CENTER OF CAR 3XXX, FLOOR LEVEL - LOW FREQ, 5-45Hz

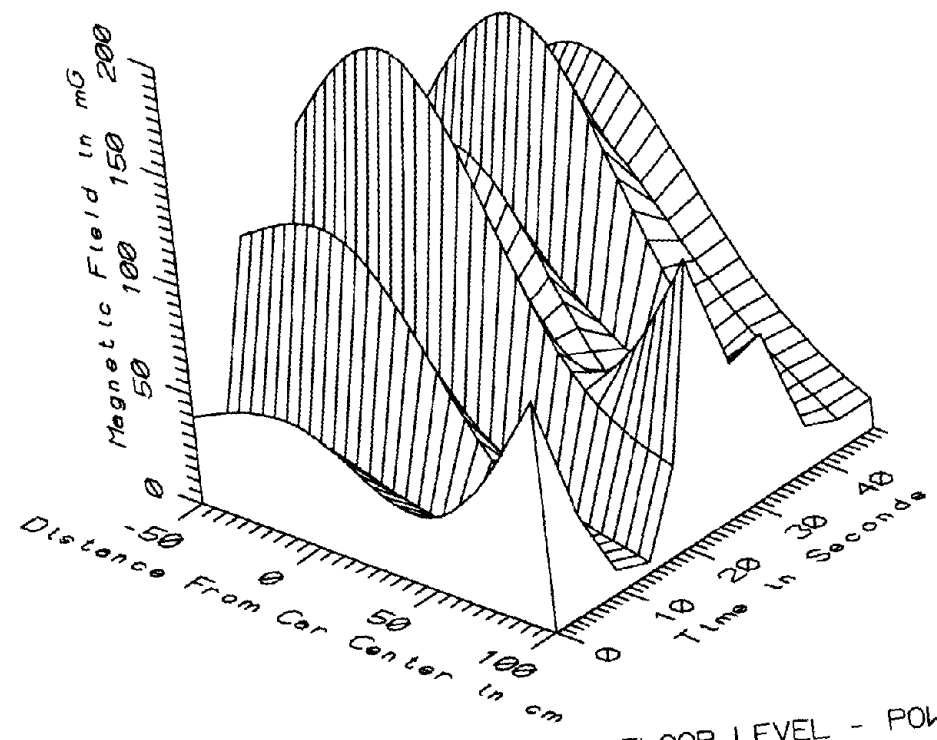

MET050 - AXIAL AT CENTER OF CAR 3XXX, FLOOR LEVEL - POWER FREQ, 50-60Hz

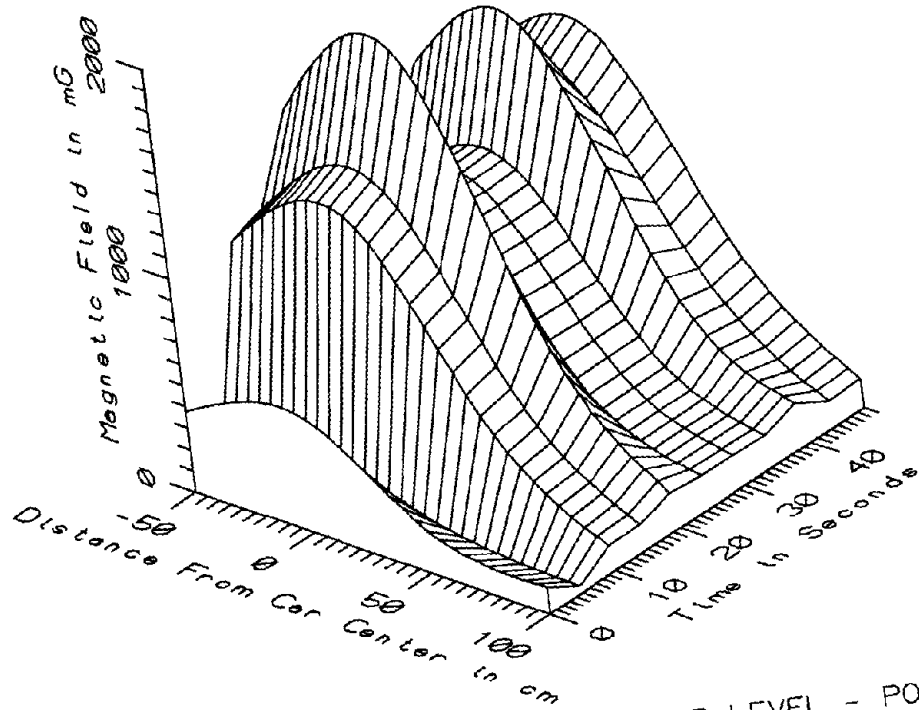

MET050 - AXIAL AT CENTER OF CAR 3XXX, FLOOR LEVEL - POWER HARM, 65-300Hz

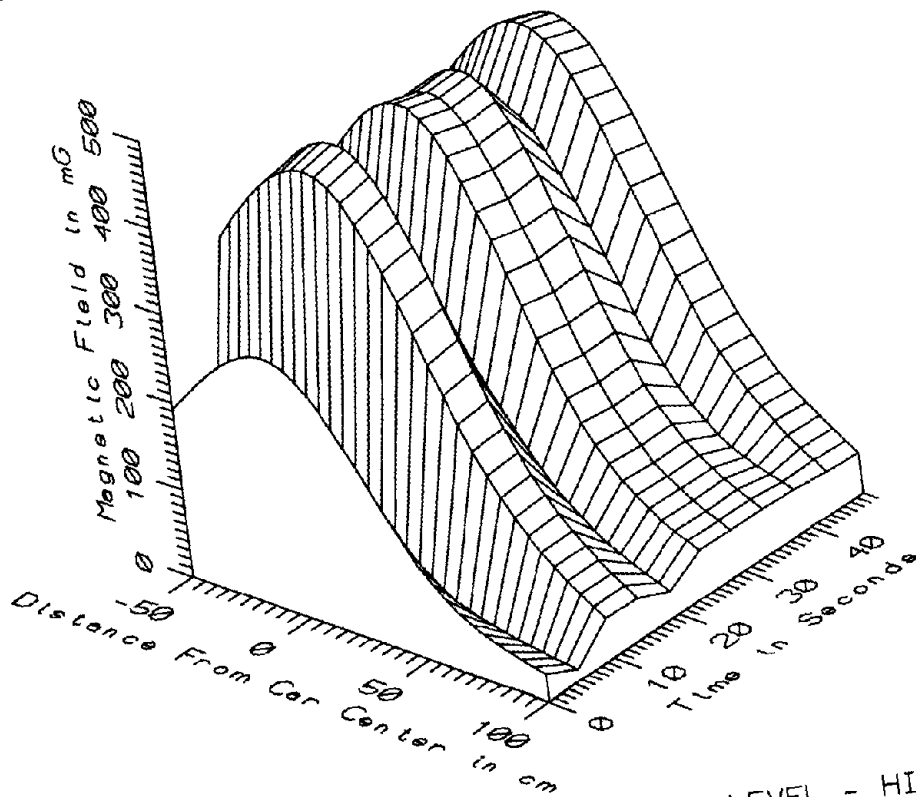

MET050 - AXIAL AT CENTER OF CAR 3XXX, FLOOR LEVEL - HIGH FREQ, 305-2560Hz

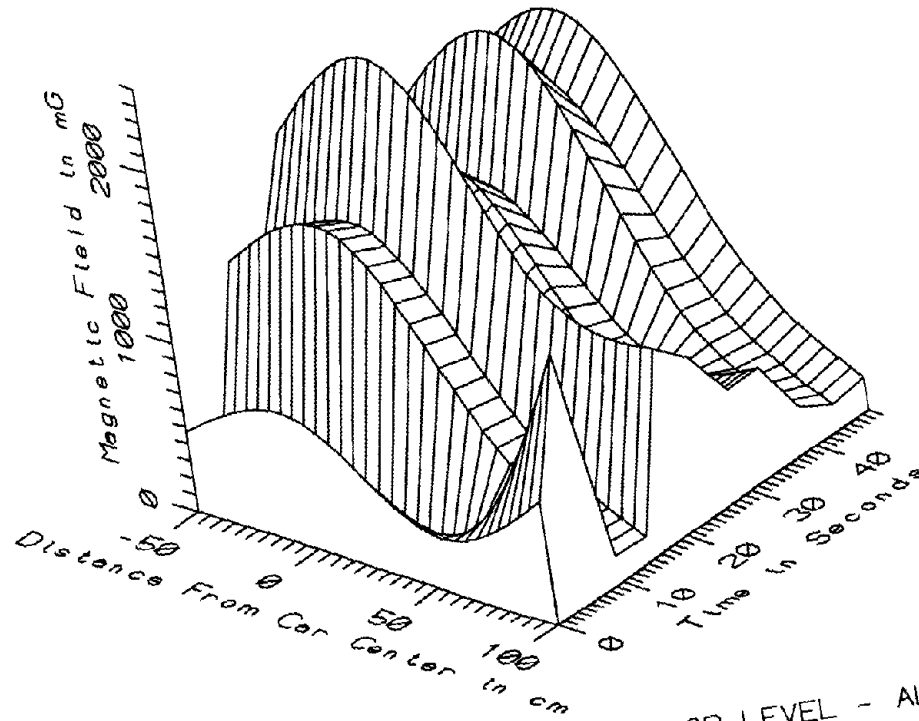

MET050 - AXIAL AT CENTER OF CAR 3XXX, FLOOR LEVEL - ALL FREQ, 5-2560Hz

MET050 - AXIAL AT CENTER OF CAR 3XXX, FLOOR LEVEL		TOTAL OF 11 SAMPLES				
FREQUENCY BAND	DIST FROM CENTER (cm)	MINIMUM MAGNETIC FIELD (mG)	MAXIMUM MAGNETIC FIELD (mG)	AVERAGE MAGNETIC FIELD (mG)	STANDARD DEVIATION (mG)	COEFFICIENT OF VARIATION (%)
5-45Hz LOW FREQ	-50	185.54	952.82	507.20	269.83	53.20
	0	288.56	1342.63	736.54	346.60	47.06
	50	150.33	1084.48	373.23	253.93	68.04
	100	34.97	1484.10	540.20	487.56	90.26
50-60Hz PWR FREQ	-50	31.07	136.52	75.90	35.46	46.72
	0	30.43	184.10	102.43	47.75	46.61
	50	18.24	81.77	45.36	18.63	41.09
	100	4.95	124.72	46.95	40.83	86.97
65-300Hz PWR HARM	-50	144.72	1415.77	869.31	362.81	41.74
	0	203.73	1892.81	1167.86	468.00	40.07
	50	78.40	784.70	478.06	197.01	41.21
	100	34.86	217.35	144.72	46.69	32.26
305-2560Hz HIGH FREQ	-50	78.39	349.58	286.46	86.28	30.12
	0	110.88	454.00	382.54	109.91	28.73
	50	43.42	194.36	156.59	47.97	30.63
	100	12.92	53.87	43.04	13.03	30.29
5-2560Hz ALL FREQ	-50	251.16	1726.84	1062.75	426.16	40.10
	0	371.48	2346.56	1454.09	545.19	37.49
	50	175.96	1346.70	641.34	295.56	46.08
	100	143.93	1485.29	590.96	453.96	76.82

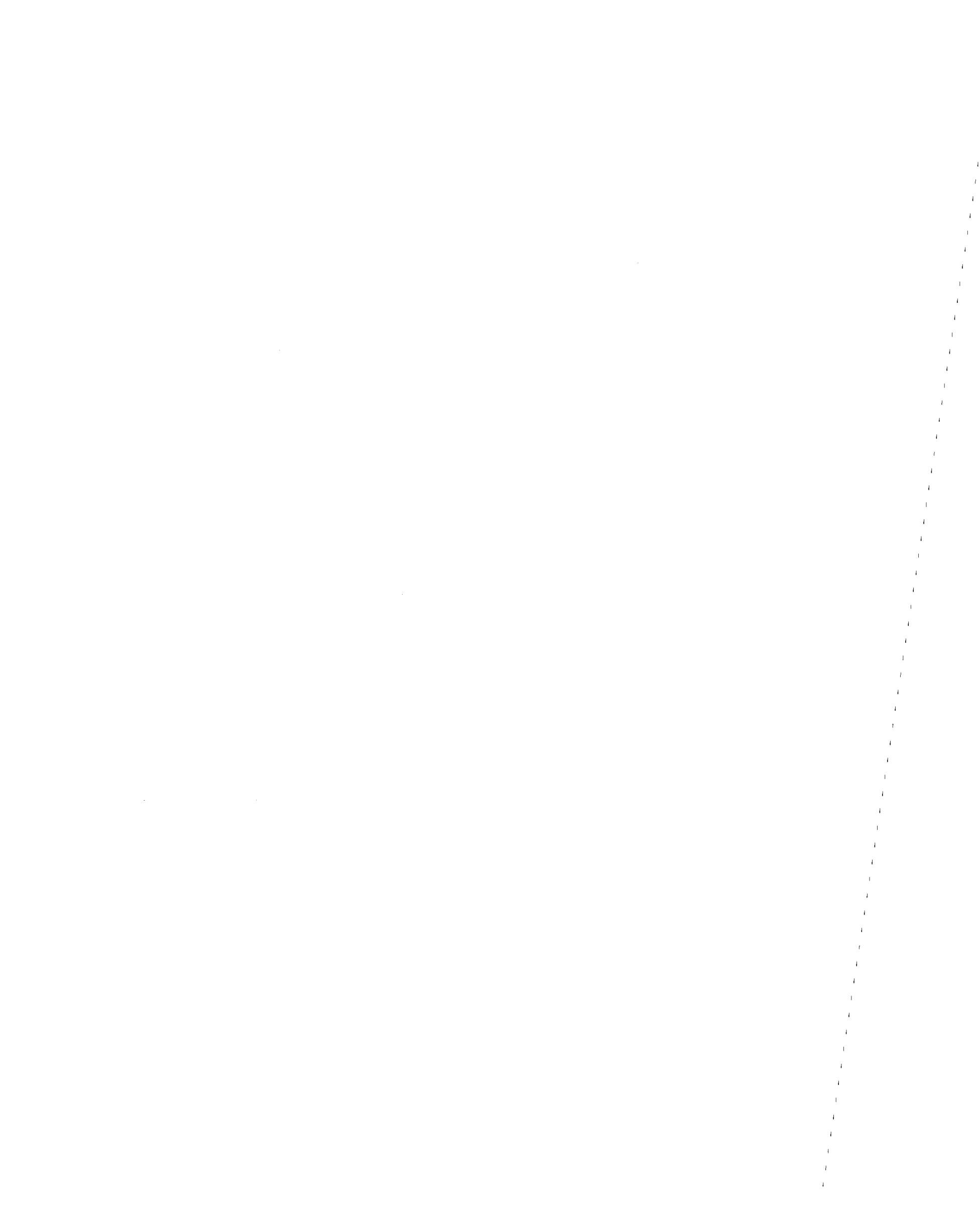

APPENDIX AU

DATASET MET051  
TRANSVERSE PROFILE IN CENTER OF A 3000 SERIES CAR,  
FLOOR LEVEL

Measurement Setup Code:        Staff:    3        Reference: -  
   Drawing:  A-1

Vehicle Status:                Traveling on the Red Line

Measurement Date:              May 20, 1992

Measurement Time:              Start:     12:09:43  
   End:       12:10:25

Number of Samples:              9

Programmed Sample Interval:    5 sec

Actual Sample Interval:        5.3 sec

Frequency Spectrum Parameters

<u>Probe Type:</u>	<u>Wideband</u>	<u>Static</u>
Maximum Frequency (Hz)	2560	NA
Minimum Frequency (Hz)	5	NA
Spectral Bandwidth (Hz)	5	NA

Missing Data: No reference probe

Saturated Data - Wideband:	<u>Sensor</u>	<u>Sample</u>	<u>Time (sec)</u>
	100cm	7	32

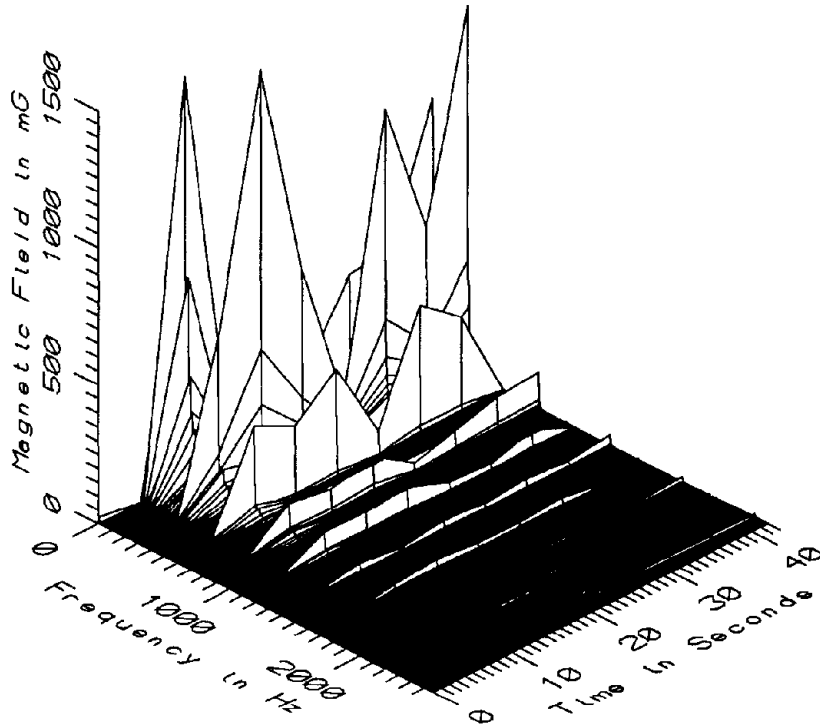

MET051 - -50cm FROM CENTERLINE, CENTER OF CAR 3XXX, FLOOR LEVEL

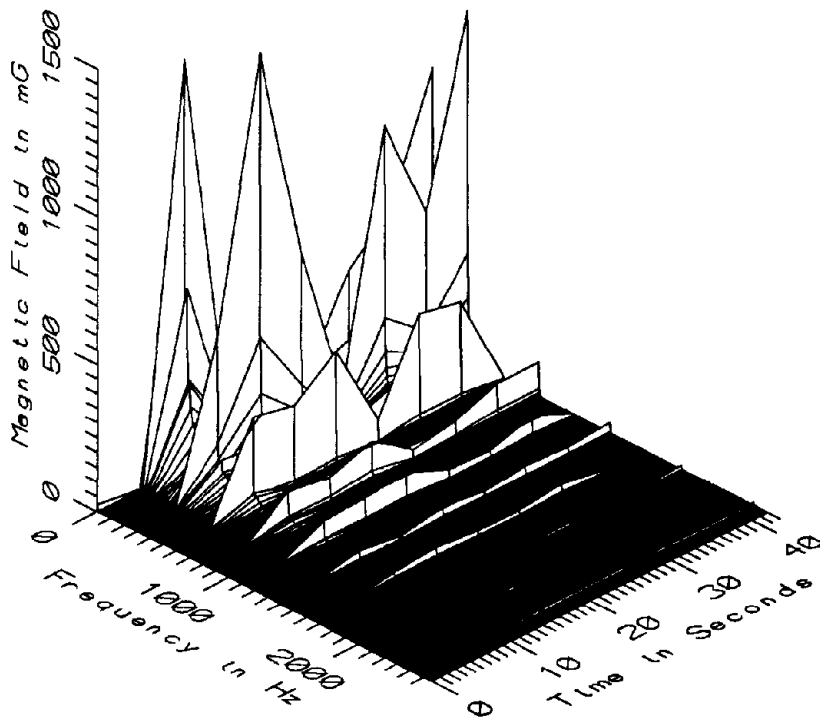

MET051 - 0cm FROM CENTERLINE, CENTER OF CAR 3XXX, FLOOR LEVEL



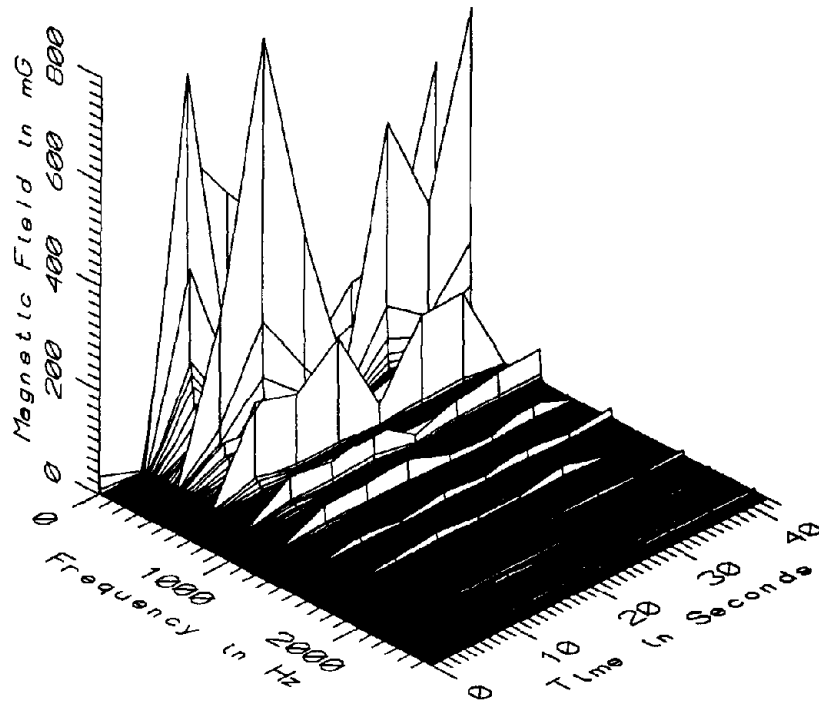

MET051 - 50cm FROM CENTERLINE, CENTER OF CAR 3XXX, FLOOR LEVEL

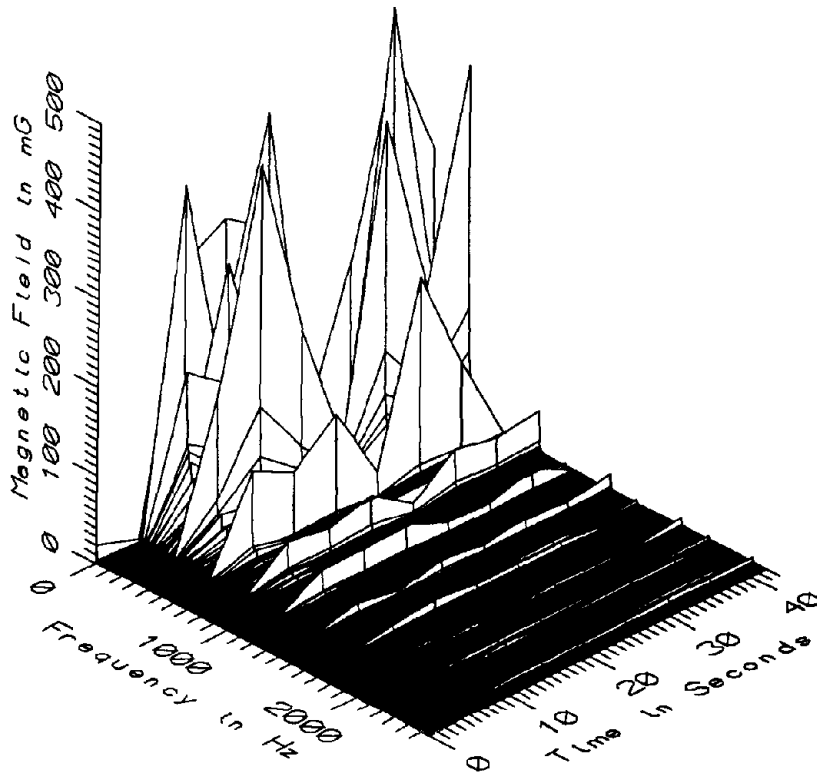

MET051 - 100cm FROM CENTERLINE, CENTER OF CAR 3XXX, FLOOR LEVEL

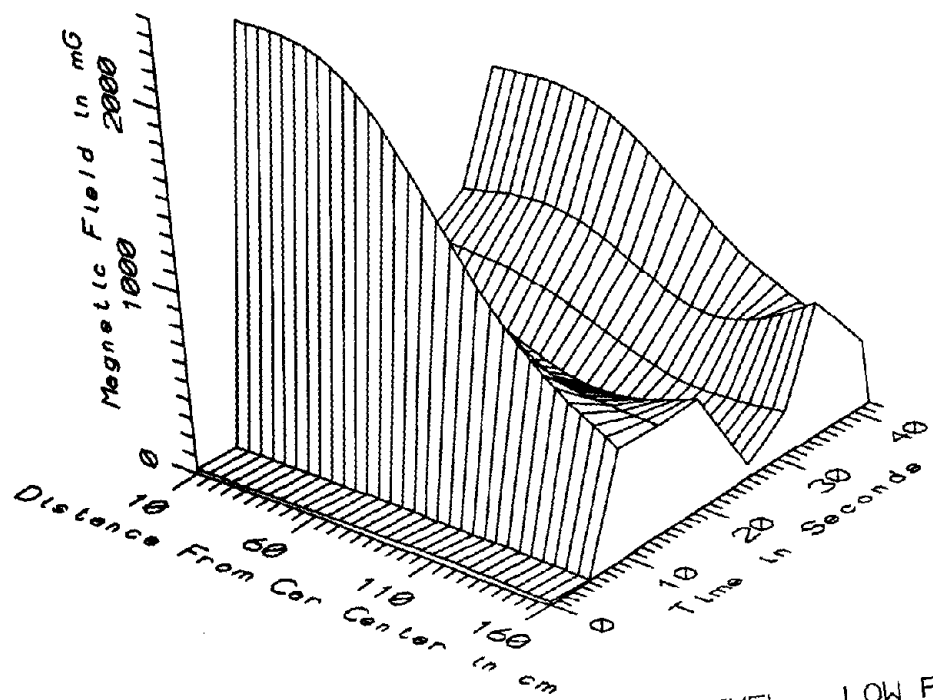

MET051 - TRANS, CENTER OF CAR 3XXX, FLOOR LEVEL - LOW FREQ, 5-45Hz

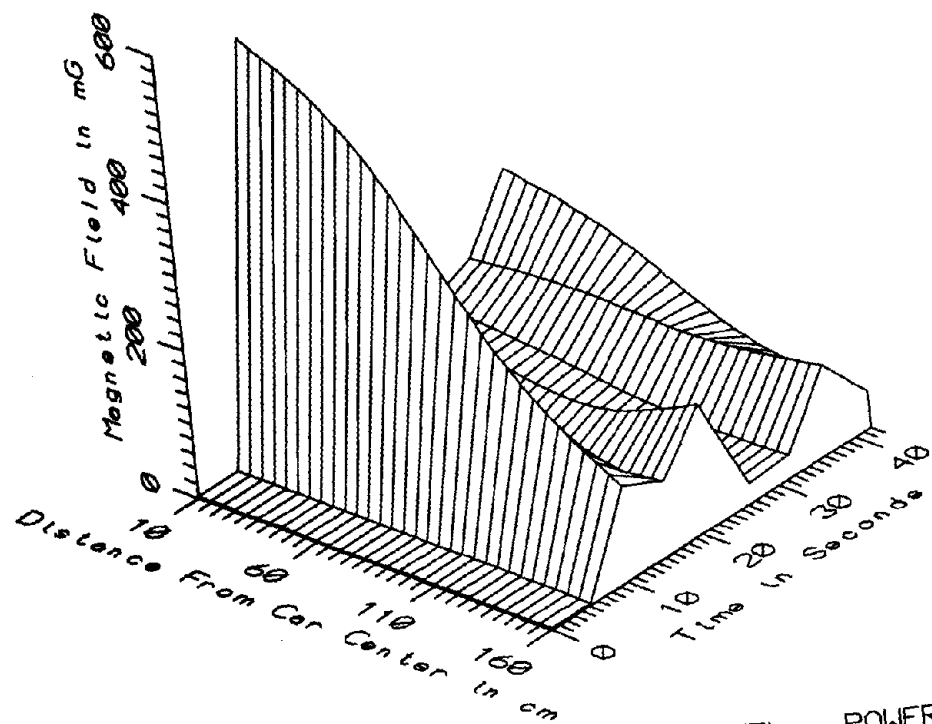

MET051 - TRANS, CENTER OF CAR 3XXX, FLOOR LEVEL - POWER FREQ, 50-60Hz

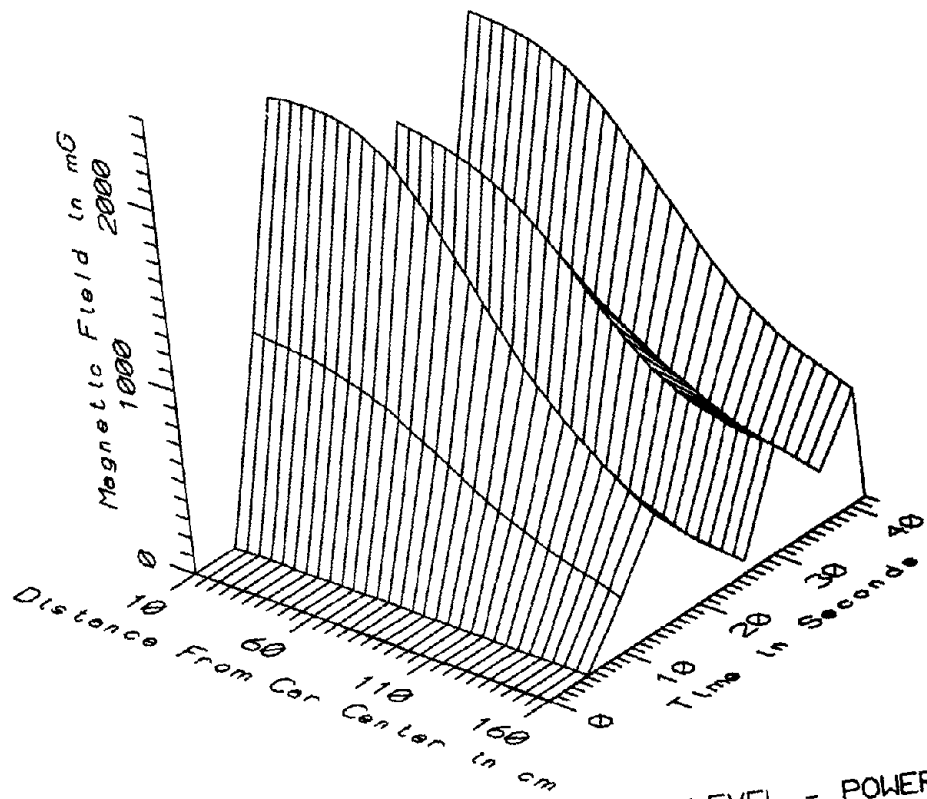

MET051 - TRANS. CENTER OF CAR 3XXX, FLOOR LEVEL - POWER HARM, 65-300Hz

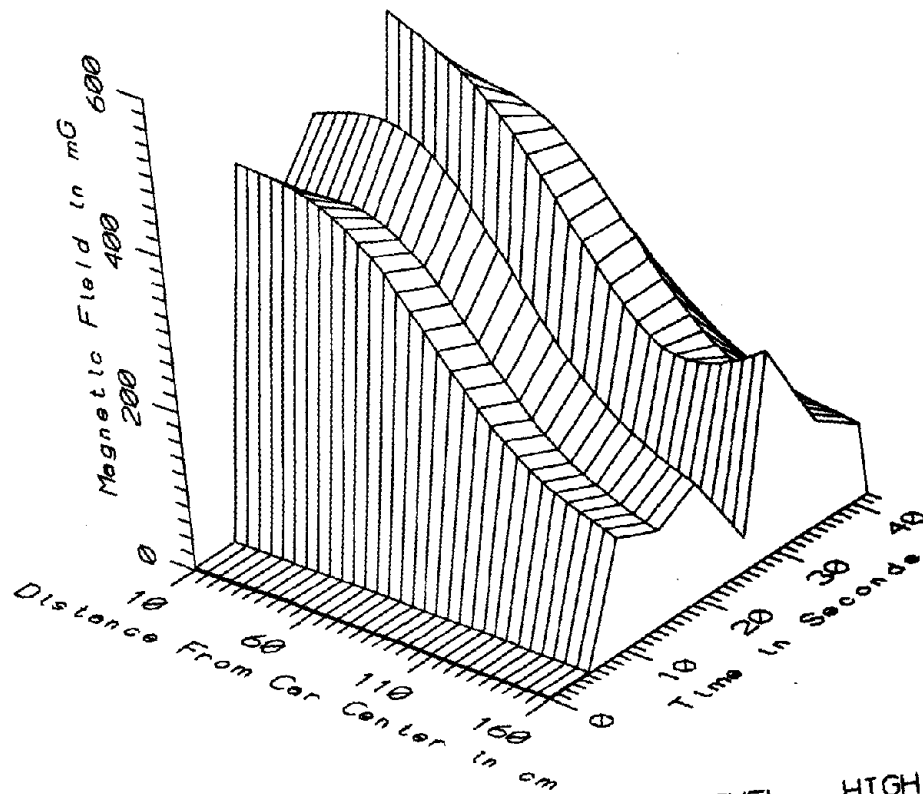

MET051 - TRANS. CENTER OF CAR 3XXX, FLOOR LEVEL - HIGH FREQ. 305-2560Hz

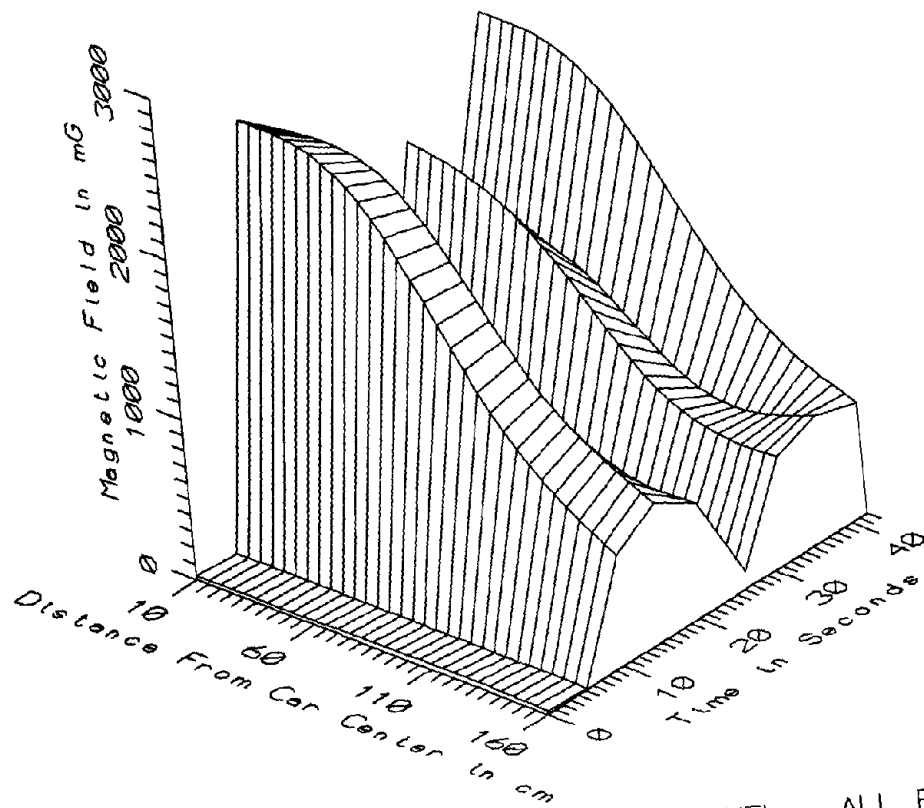

MET051 - TRANS, CENTER OF CAR 3XXX, FLOOR LEVEL - ALL FREQ, 5-2560Hz

MET051 - TRANSVERSE, CENTER OF CAR 3XXX, FLOOR LEVEL		TOTAL OF 9 SAMPLES				
FREQUENCY BAND	DIST FROM CENTER (cm)	MINIMUM MAGNETIC FIELD (mG)	MAXIMUM MAGNETIC FIELD (mG)	AVERAGE MAGNETIC FIELD (mG)	STANDARD DEVIATION (mG)	COEFFICIENT OF VARIATION (%)
5-45Hz LOW FREQ	-50	5.87	2213.33	674.12	675.36	100.18
	0	7.01	2049.32	643.20	634.05	98.58
	50	5.21	1117.23	389.93	355.36	91.13
	100	5.07	688.05	339.99	270.08	79.44
50-60Hz PWR FREQ	-50	2.45	556.24	127.62	169.13	132.52
	0	2.14	454.09	112.23	137.59	122.60
	50	2.80	250.03	73.33	77.29	105.41
	100	2.51	168.70	69.96	60.38	86.29
65-300Hz PWR HARM	-50	1.99	2204.69	1003.82	824.08	82.09
	0	2.22	2082.19	910.59	750.95	82.47
	50	1.79	1176.80	510.57	417.22	81.72
	100	1.55	606.44	302.57	245.50	81.14
305-2560Hz HIGH FREQ	-50	2.93	516.05	288.77	200.13	69.31
	0	2.55	453.08	266.15	183.80	69.06
	50	1.90	247.04	142.66	97.95	68.66
	100	1.65	244.98	99.79	77.45	77.62
5-2560Hz ALL FREQ	-50	7.35	2552.22	1317.77	1003.63	76.16
	0	8.08	2323.89	1213.59	924.04	76.14
	50	6.47	1343.72	691.28	521.14	75.39
	100	6.09	843.43	494.59	342.64	69.28



APPENDIX AV

DATASET MET052  
TRANSVERSE PROFILE IN CENTER OF A 3000 SERIES CAR,  
1 m (3.3 ft) ABOVE FLOOR

Measurement Setup Code:      Staff:    3      Reference: -  
   Drawing: A-1

Vehicle Status:                    Traveling on the Red Line

Measurement Date:                May 20, 1992

Measurement Time:                Start:    12:10:45  
   End:      12:10:55

Number of Samples:                3

Programmed Sample Interval:    5 sec

Actual Sample Interval:         5.0 sec

Frequency Spectrum Parameters

<u>Probe Type:</u>	<u>Wideband</u>	<u>Static</u>
Maximum Frequency (Hz)	2560	NA
Minimum Frequency (Hz)	5	NA
Spectral Bandwidth (Hz)	5	NA

Missing Data: No reference probe

Saturated Data: None

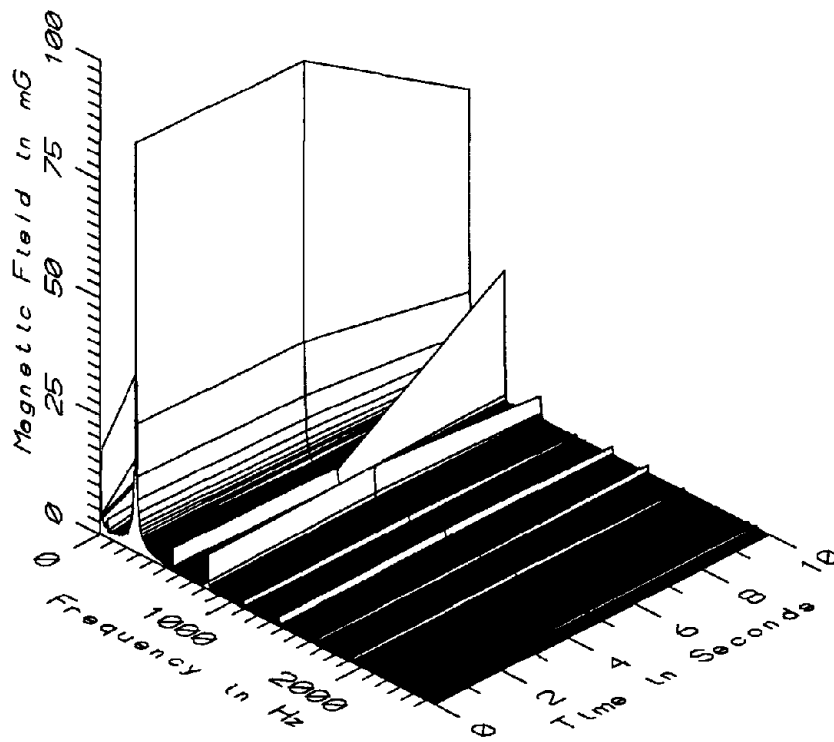

MET052 - -50cm FROM CENTERLINE, CENTER OF CAR 3XXX, 1M ABOVE FLOOR

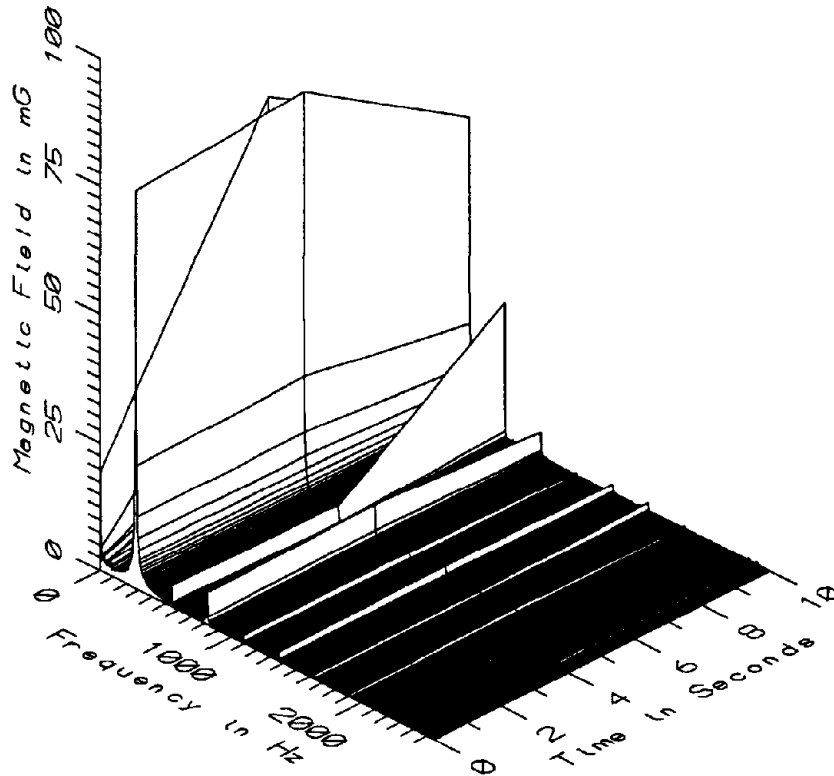

MET052 - 0cm FROM CENTERLINE, CENTER OF CAR 3XXX, 1M ABOVE FLOOR



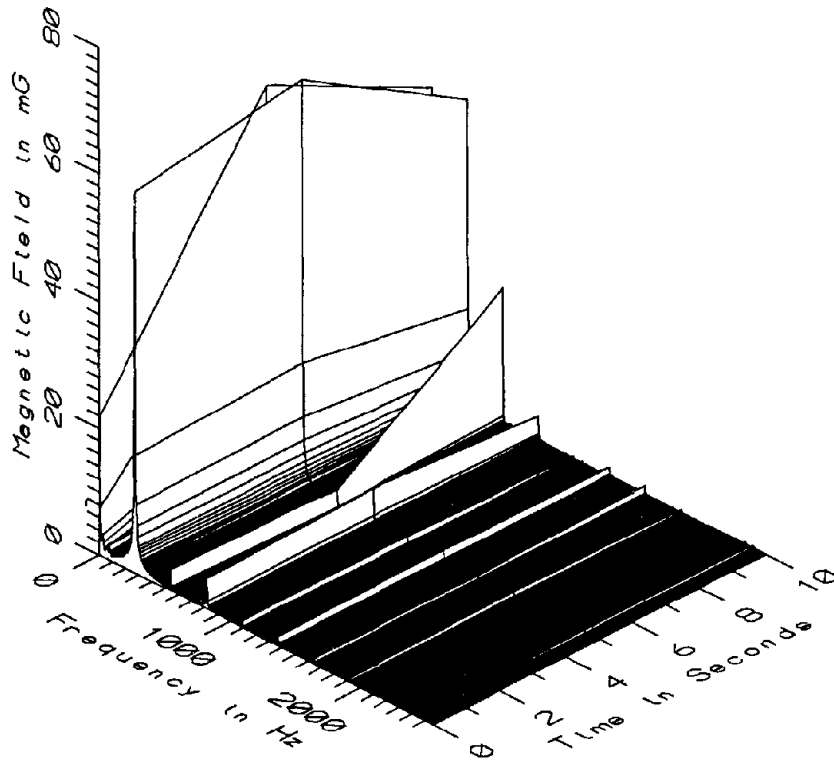

MET052 - 50cm FROM CENTERLINE, CENTER OF CAR 3XXX, 1M ABOVE FLOOR

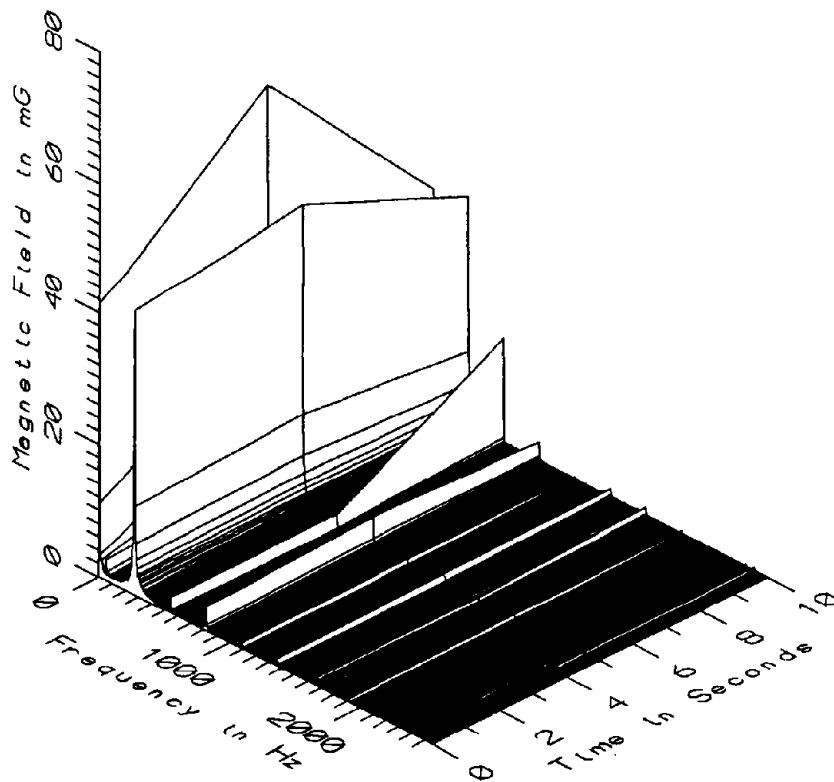

MET052 - 100cm FROM CENTERLINE, CENTER OF CAR 3XXX, 1M ABOVE FLOOR

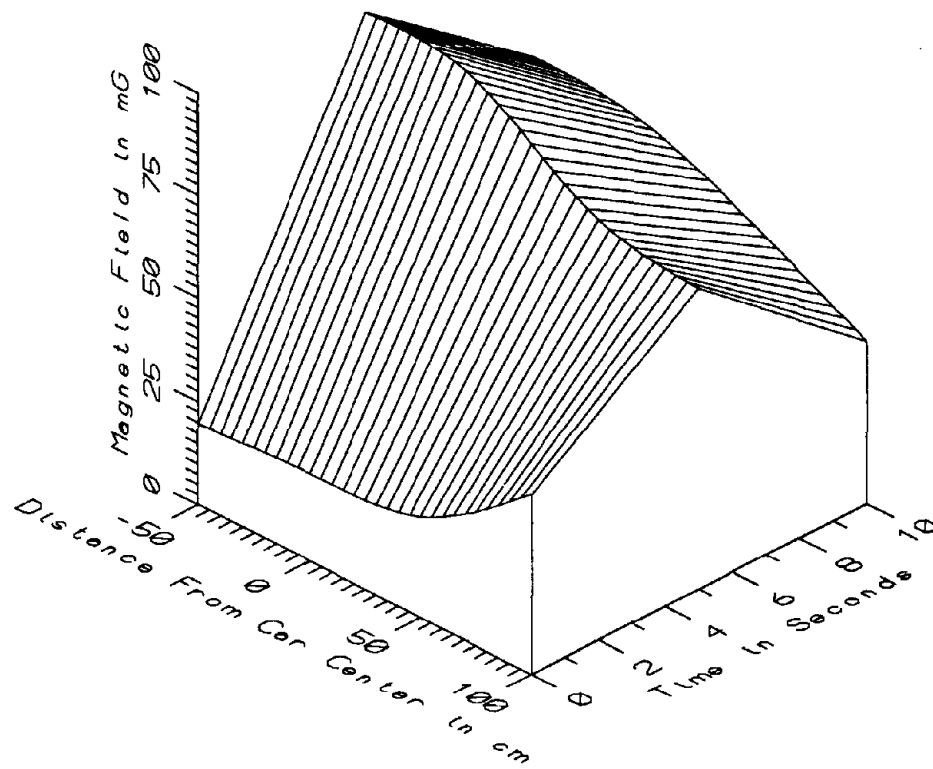

MET052 - TRANS, CENTER OF CAR 3XXX, 1M ABOVE FLOOR - LOW FREQ, 5-45Hz

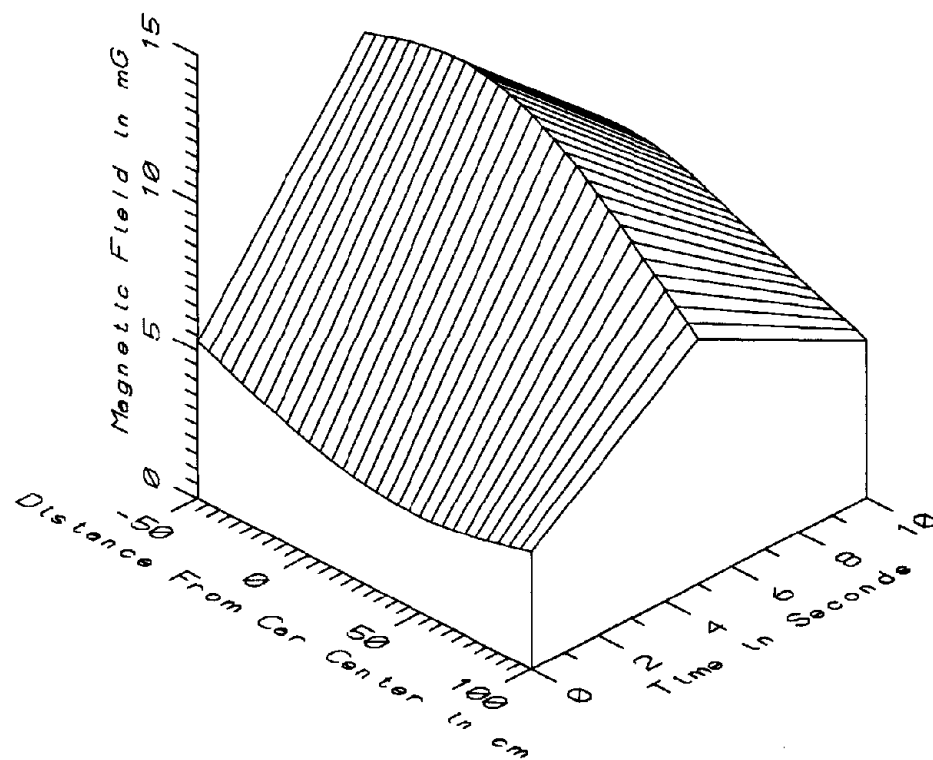

MET052 - TRANS, CENTER OF CAR 3XXX, 1M ABOVE FLOOR - POWER FREQ, 50-60Hz

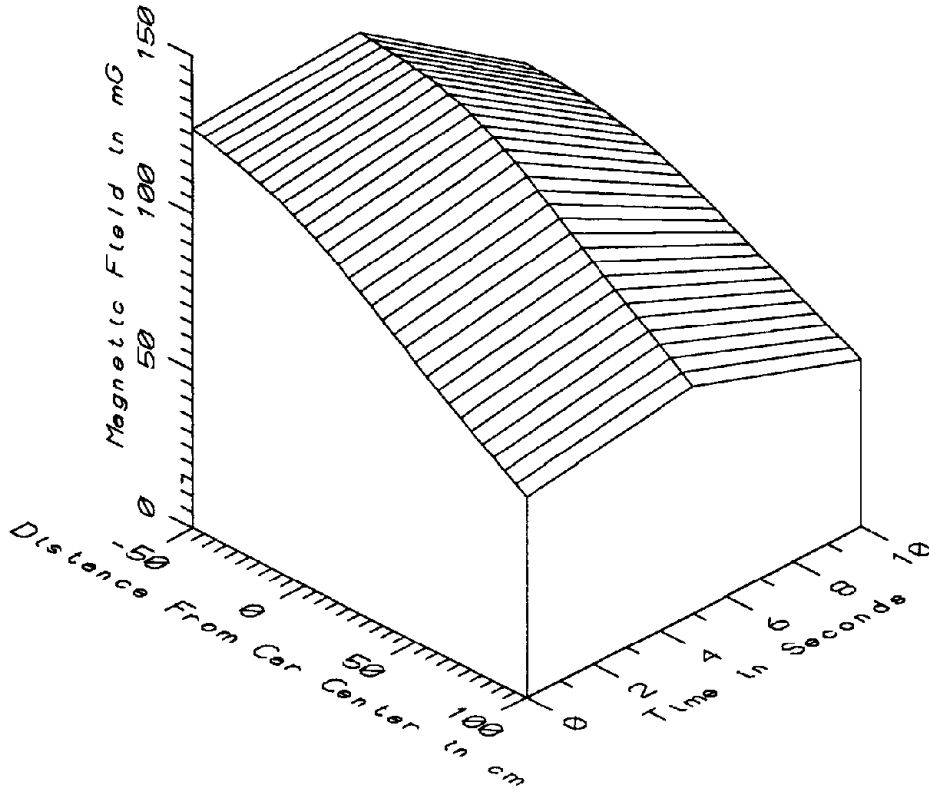

MET052 - TRANS, CENTER OF CAR 3XXX, 1M ABOVE FLOOR - POWER HARM, 65-300Hz

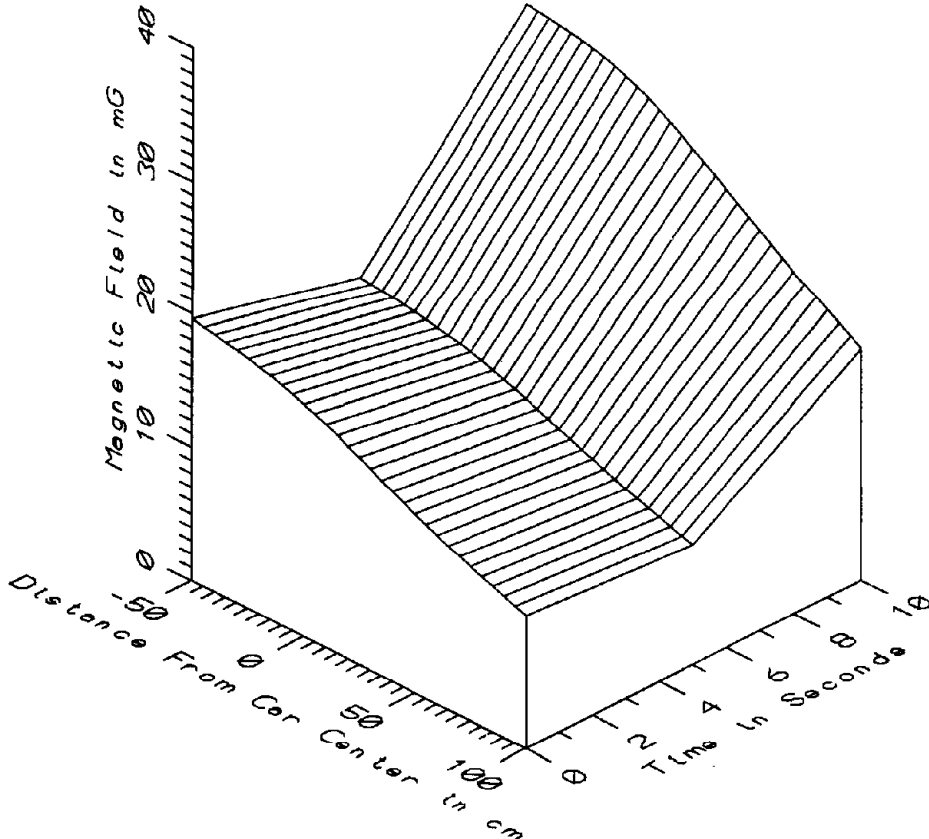

MET052 - TRANS, CENTER OF CAR 3XXX, 1M ABOVE FLOOR - HIGH FREQ, 305-2560Hz

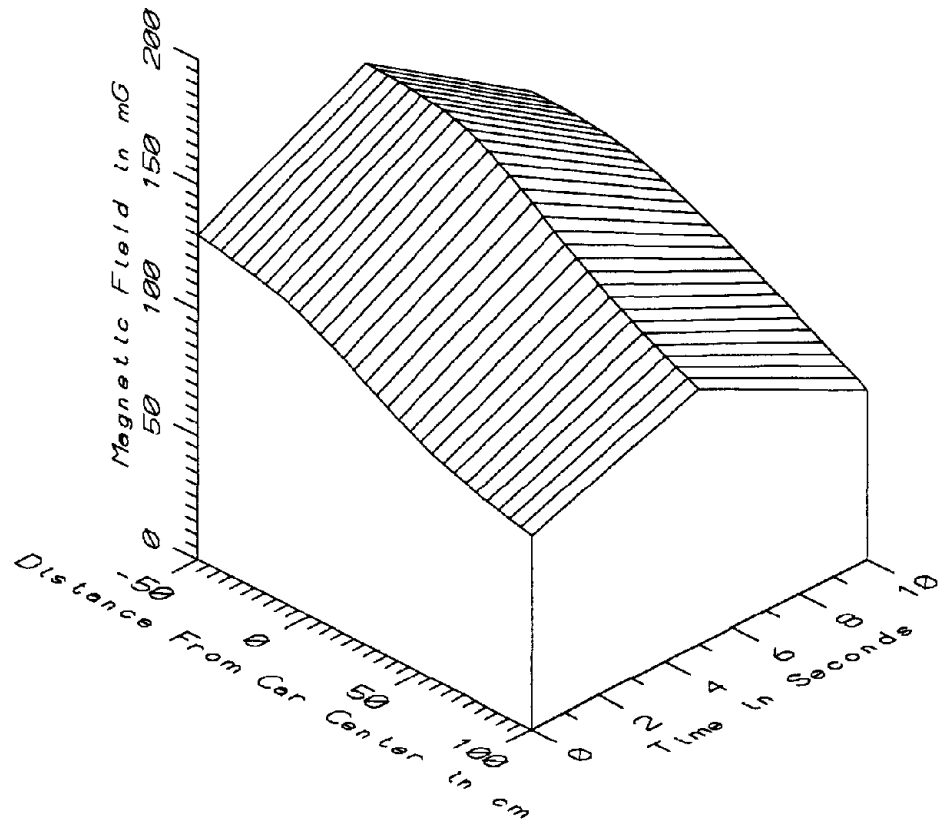

MET052 - TRANS, CENTER OF CAR 3XXX, 1M ABOVE FLOOR - ALL FREQ, 5-2560Hz

MET052 - TRANSVERSE, CENTER OF CAR 3XXX, 1M ABOVE FLOOR TOTAL OF 3 SAMPLES										
FREQUENCY BAND	DIST FROM CENTER (cm)	MINIMUM MAGNETIC FIELD (mG)	MAXIMUM MAGNETIC FIELD (mG)	AVERAGE MAGNETIC FIELD (mG)	STANDARD DEVIATION (mG)	COEFFICIENT OF VARIATION (%)				
5-45HZ LOW FREQ	-50	19.63	99.09	62.30	40.06	64.30				
	0	21.26	96.02	60.96	37.59	61.66				
	50	24.27	78.35	52.13	27.08	51.94				
	100	39.19	72.60	51.73	18.19	35.17				
50-60HZ PWR FREQ	-50	5.31	12.89	8.66	3.87	44.65				
	0	3.80	13.57	8.57	4.89	57.00				
	50	3.19	11.68	7.28	4.25	58.43				
	100	3.93	8.23	5.83	2.19	37.53				
65-300HZ PWR HARM	-50	93.60	130.23	116.87	20.23	17.31				
	0	88.67	122.29	108.25	17.48	16.15				
	50	72.29	98.04	86.05	12.97	15.07				
	100	52.80	71.12	62.30	9.18	14.74				
305-2560HZ HIGH FREQ	-50	16.44	30.55	22.20	7.40	33.34				
	0	14.97	28.62	20.34	7.28	35.79				
	50	11.90	23.09	16.14	6.07	37.59				
	100	8.99	17.31	12.09	4.55	37.62				
5-2560HZ ALL FREQ	-50	120.02	164.96	138.30	23.62	17.08				
	0	114.26	156.79	129.39	23.77	18.37				
	50	92.17	126.61	104.01	19.57	18.82				
	100	68.21	102.36	82.60	17.70	21.43				



APPENDIX AW

DATASET MET053  
AXIAL PROFILE IN CENTER OF A 3000 SERIES CAR,  
1 m (3.3 ft) ABOVE FLOOR

Measurement Setup Code:        Staff:     2     Reference: -  
   Drawing:    A-1

Vehicle Status:                    Traveling on the Red Line

Measurement Date:                May 20, 1992

Measurement Time:                Start:     12:11:16  
   End:        12:13:30

Number of Samples:                28

Programmed Sample Interval:     5 sec

Actual Sample Interval:         5.0 sec

Frequency Spectrum Parameters

<u>Probe Type:</u>	<u>Wideband</u>	<u>Static</u>
Maximum Frequency (Hz)	2560	NA
Minimum Frequency (Hz)	5	NA
Spectral Bandwidth (Hz)	5	NA

Missing Data: No reference probe

Saturated Data: None

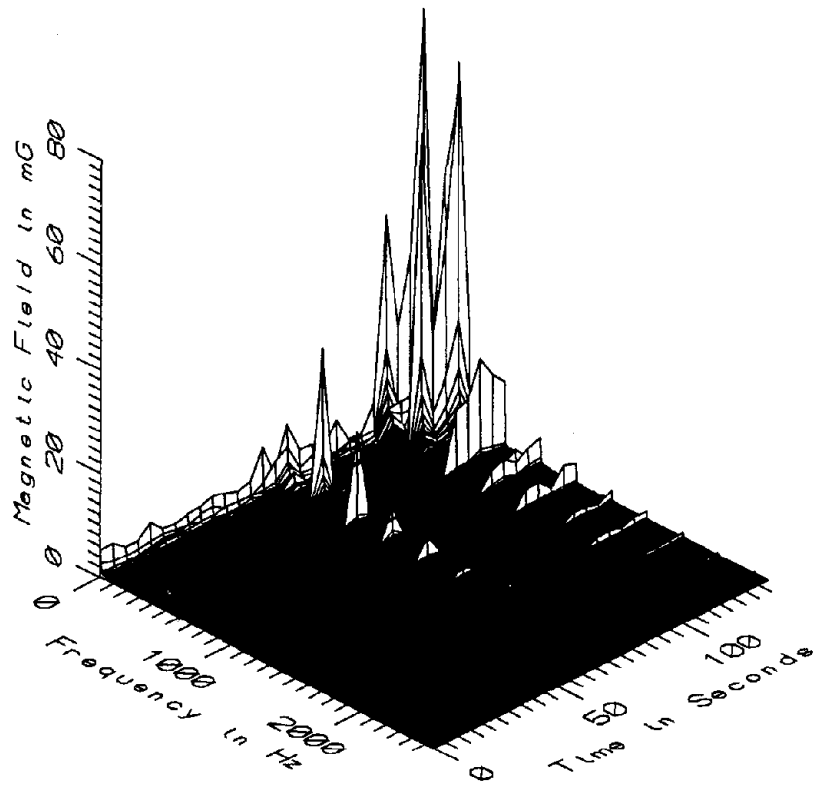

MET053 - -50cm FROM CENTER OF CAR 3XXX ALONG AXIS, 1M ABOVE FLOOR

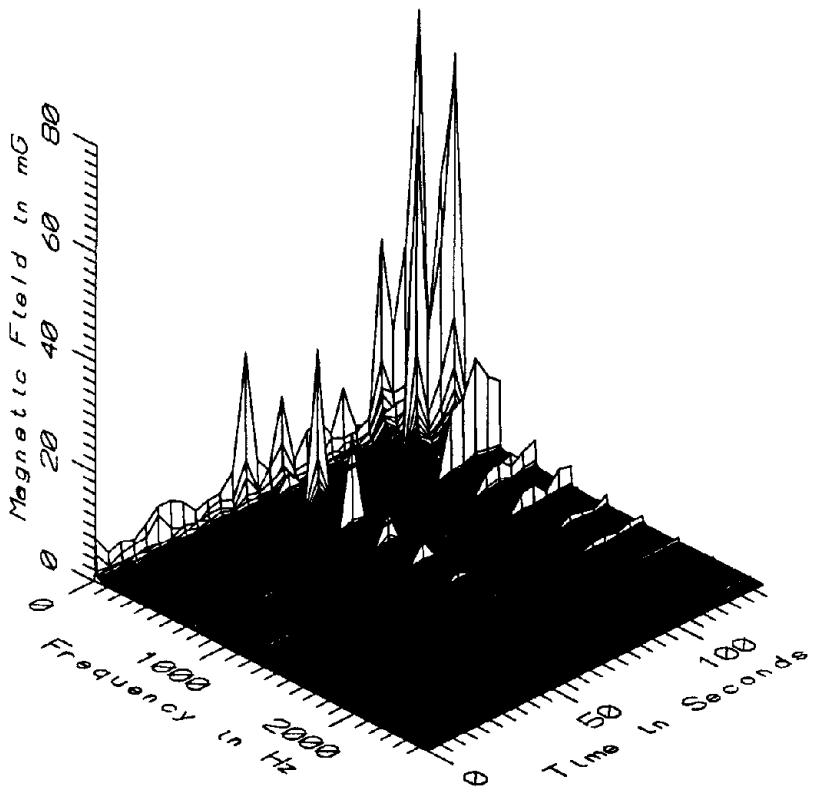

MET053 - 0cm FROM CENTER OF CAR 3XXX ALONG AXIS, 1M ABOVE FLOOR



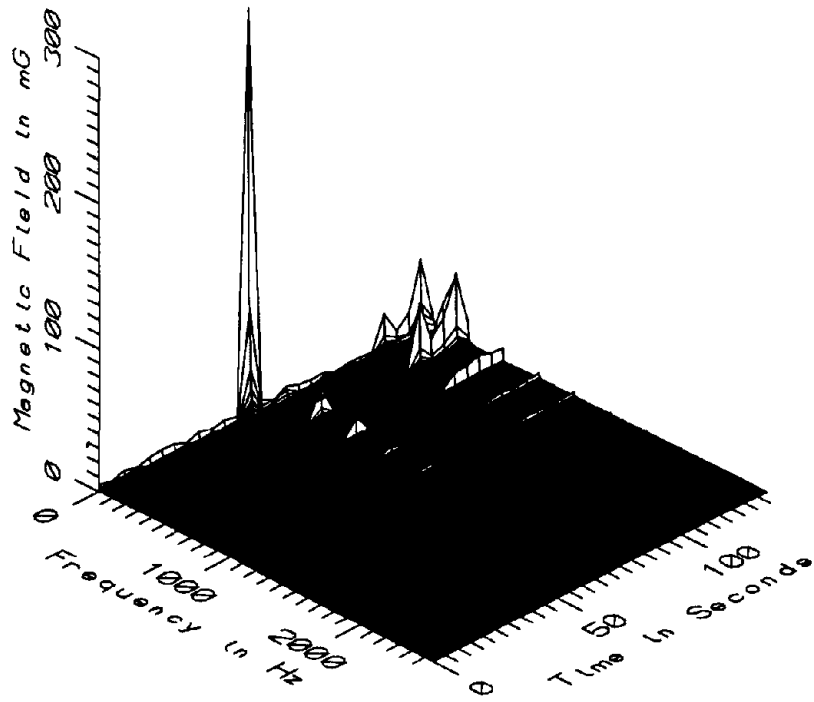

MET053 - 50cm FROM CENTER OF CAR 3XXX ALONG AXIS, 1M ABOVE FLOOR

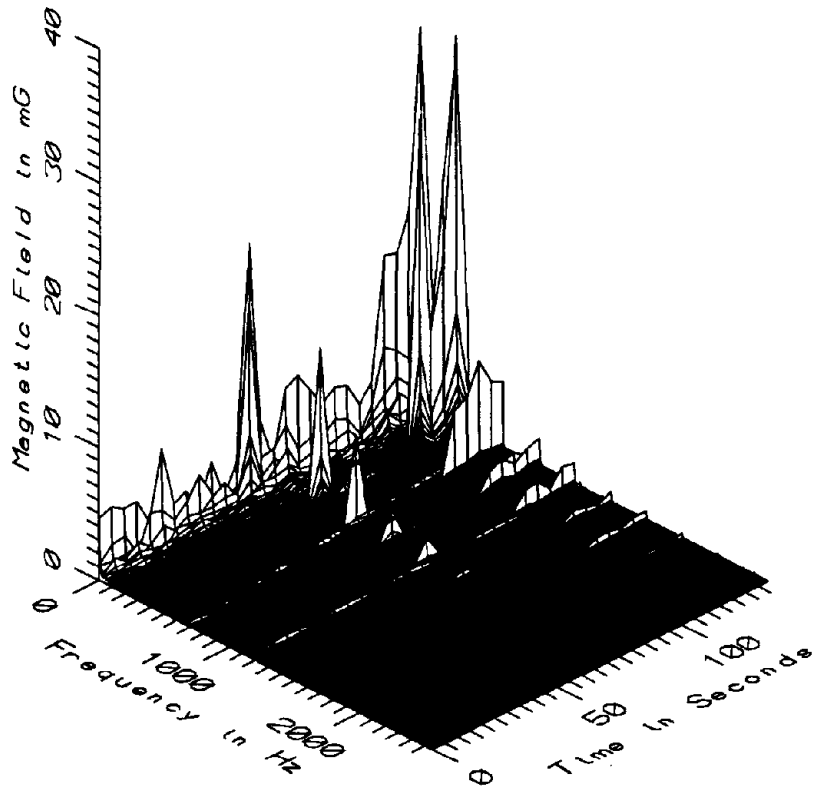

MET053 - 100cm FROM CENTER OF CAR 3XXX ALONG AXIS, 1M ABOVE FLOOR

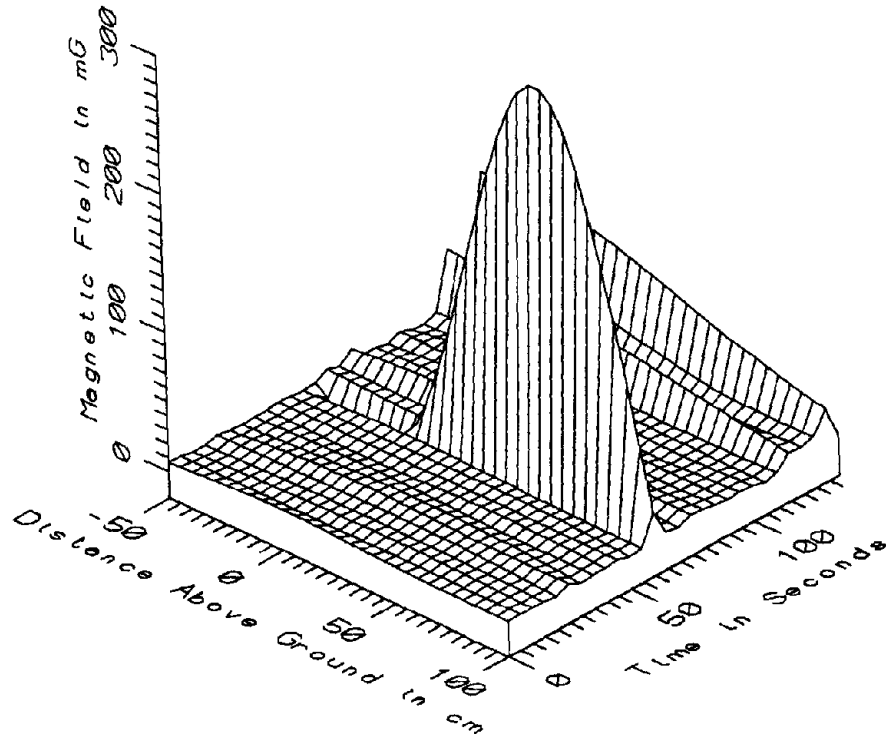

MET053 - AXIAL, CENTER OF CAR 3XXX, 1M ABOVE FLOOR - LOW FREQ, 5-45Hz

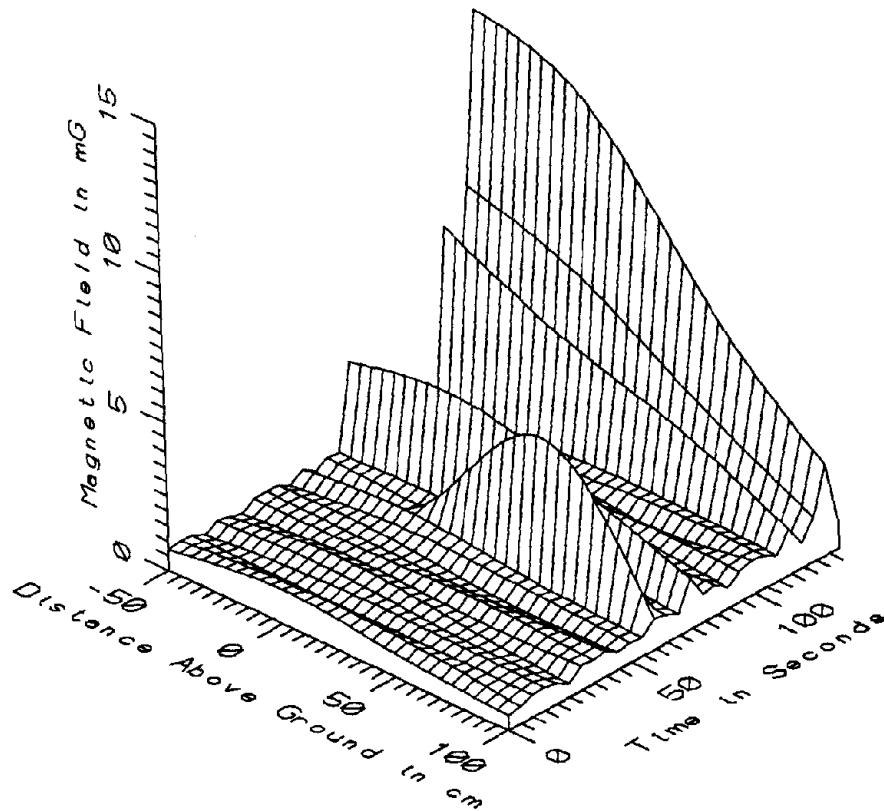

MET053 - AXIAL, CENTER OF CAR 3XXX, 1M ABOVE FLOOR - POWER FREQ, 50-60Hz

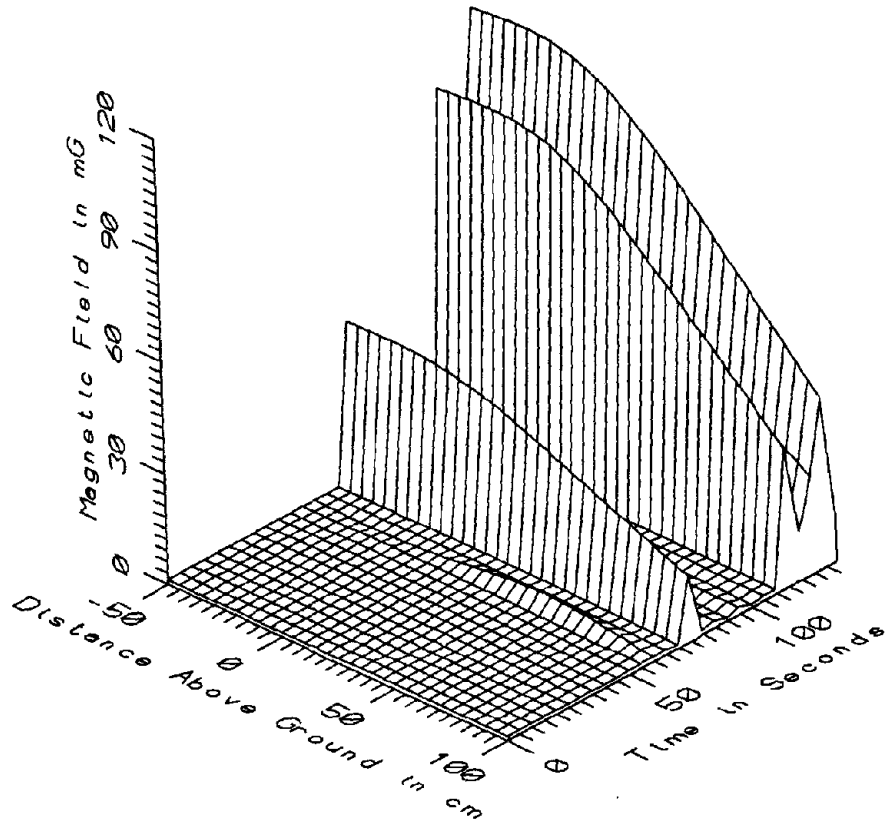

MET053 - AXIAL, CENTER OF CAR 3XXX, 1M ABOVE FLOOR - POWER HARM, 65-300Hz

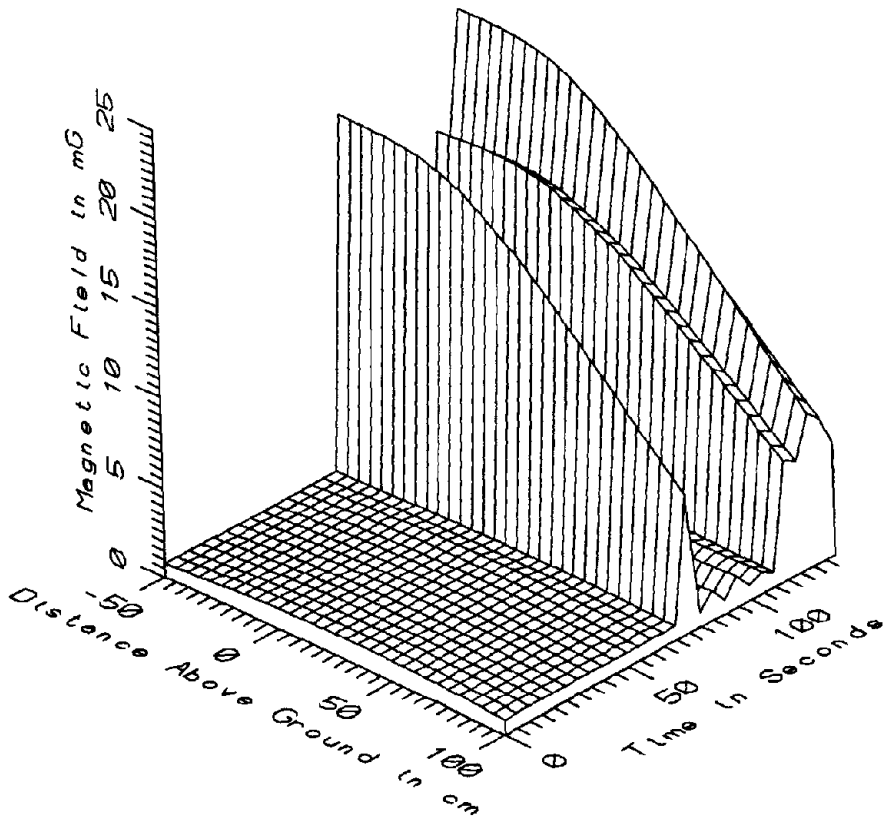

MET053 - AXIAL, CENTER OF CAR 3XXX, 1M ABOVE FLOOR - HIGH FREQ, 305-2560Hz

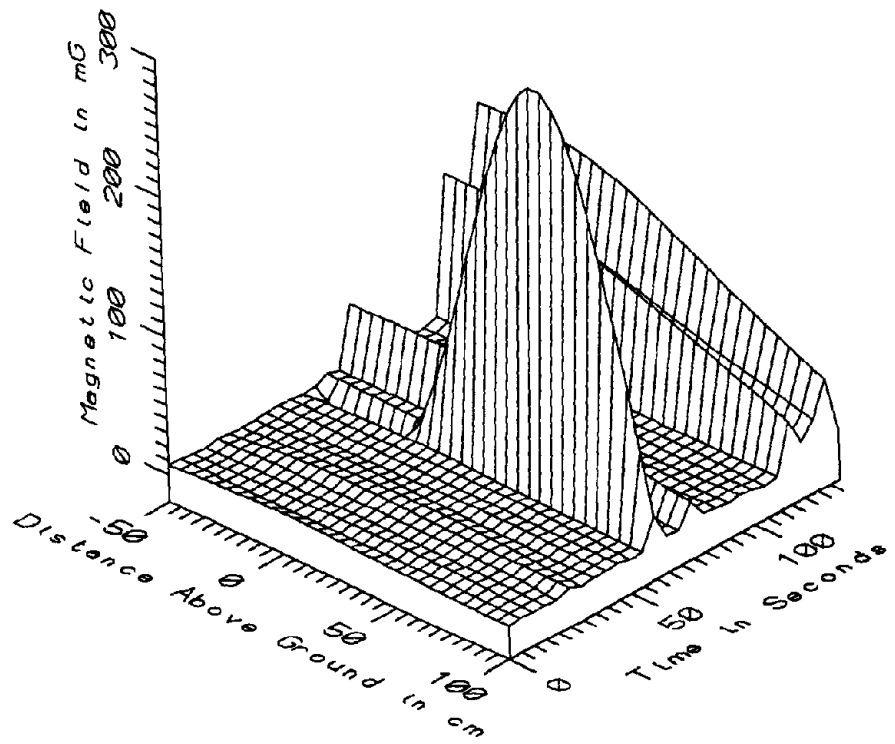

MET053 - AXIAL, CENTER OF CAR 3XXX, 1M ABOVE FLOOR - ALL FREQ, 5-2560Hz

IMET053 - AXIAL AT CENTER OF CAR 3XXX, 1M ABOVE FLOOR										TOTAL OF 28 SAMPLES	
FREQUENCY BAND	DIST FROM CENTER (cm)	MINIMUM MAGNETIC FIELD (mG)	MAXIMUM MAGNETIC FIELD (mG)	AVERAGE MAGNETIC FIELD (mG)	STANDARD DEVIATION (mG)	COEFFICIENT OF VARIATION (%)					
5-45Hz LOW FREQ	-50	4.19	90.75	12.86	18.49	143.80					
	0	5.17	85.59	14.79	16.89	114.22					
	50	4.63	296.84	21.21	55.03	259.46					
	100	3.96	33.44	9.05	7.01	77.43					
50-60Hz PWR FREQ	-50	0.53	13.08	1.92	2.78	144.75					
	0	0.66	11.53	1.84	2.31	125.19					
	50	0.48	6.74	1.53	1.53	99.62					
	100	0.44	3.05	0.97	0.51	52.18					
65-300Hz PWR HARM	-50	1.04	108.82	14.55	29.35	201.79					
	0	1.27	106.89	14.40	28.65	198.99					
	50	1.28	80.59	11.13	21.20	190.38					
	100	0.99	45.83	6.49	11.74	180.91					
305-2560Hz HIGH FREQ	-50	0.72	22.40	4.64	7.43	160.07					
	0	0.98	21.49	4.75	7.06	148.49					
	50	1.01	15.62	3.74	5.07	135.44					
	100	0.80	8.64	2.30	2.71	118.02					
5-2560Hz ALL FREQ	-50	4.64	143.70	21.49	34.71	161.48					
	0	5.54	138.77	23.23	32.72	140.88					
	50	5.47	296.93	27.80	57.58	207.11					
	100	4.29	57.36	12.44	13.01	104.61					



**APPENDIX AX**

**DATASET MET054  
BENEATH METRORAIL AT HIGHWAY UNDERPASS**

Measurement Setup Code:        Staff:    12    Reference: -  
   Drawing: A-2

Vehicle Status:                    NA

Measurement Date:                May 20, 1992

Measurement Time:                Start:    14:16:36  
   End:      14:27:46

Number of Samples:                133

Programmed Sample Interval:    5 sec

Actual Sample Interval:         5.1 sec

**Frequency Spectrum Parameters**

<u>Probe Type:</u>	<u>Wideband</u>	<u>Static</u>
Maximum Frequency (Hz)	2560	100
Minimum Frequency (Hz)	5	0
Spectral Bandwidth (Hz)	5	1

Missing Data: No reference probe

Saturated Data: None

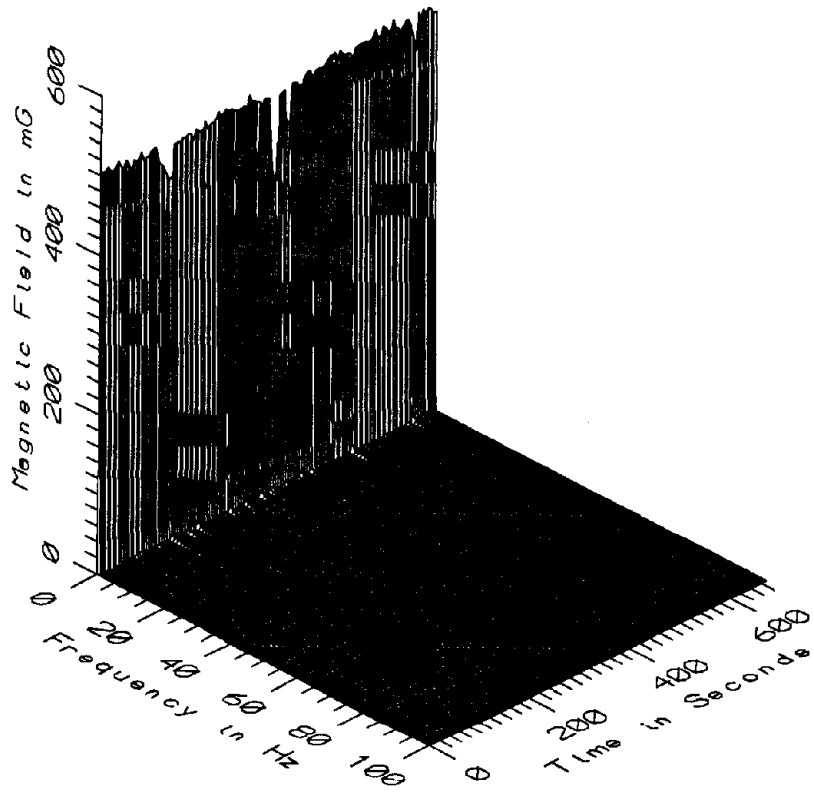

MET054 - 10cm ABOVE GROUND, BENEATH METRORAIL IN UNDERPASS

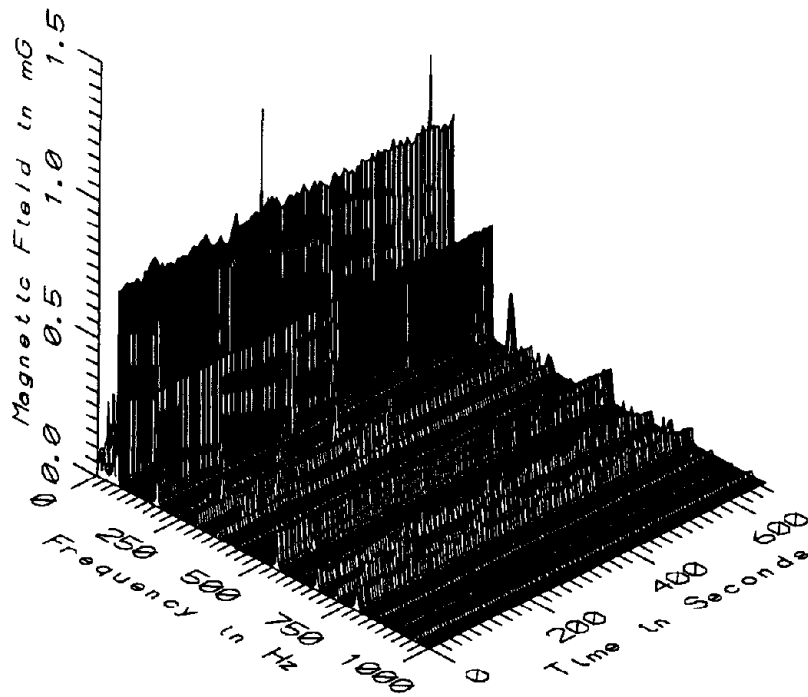

MET054 - 10cm ABOVE GROUND, BENEATH METRORAIL IN UNDERPASS



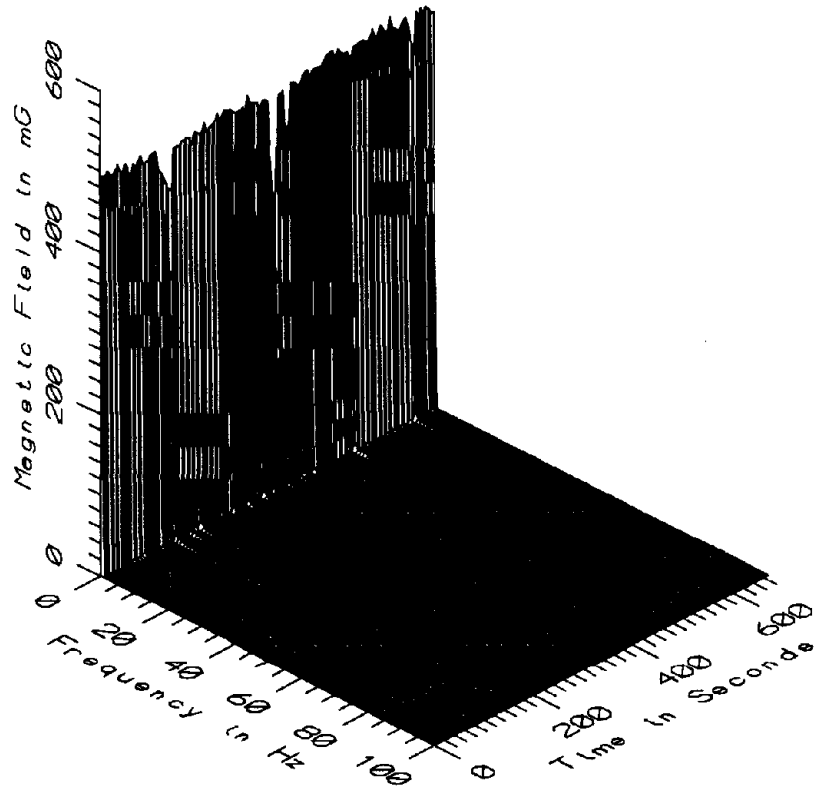

MET054 - 60cm ABOVE GROUND, BENEATH METRORAIL IN UNDERPASS

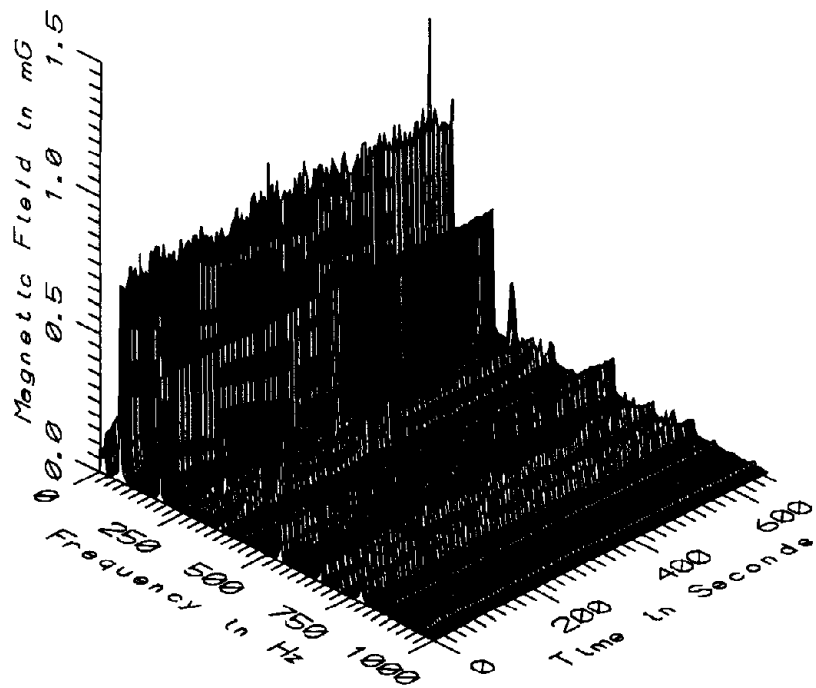

MET054 - 60cm ABOVE GROUND, BENEATH METRORAIL IN UNDERPASS

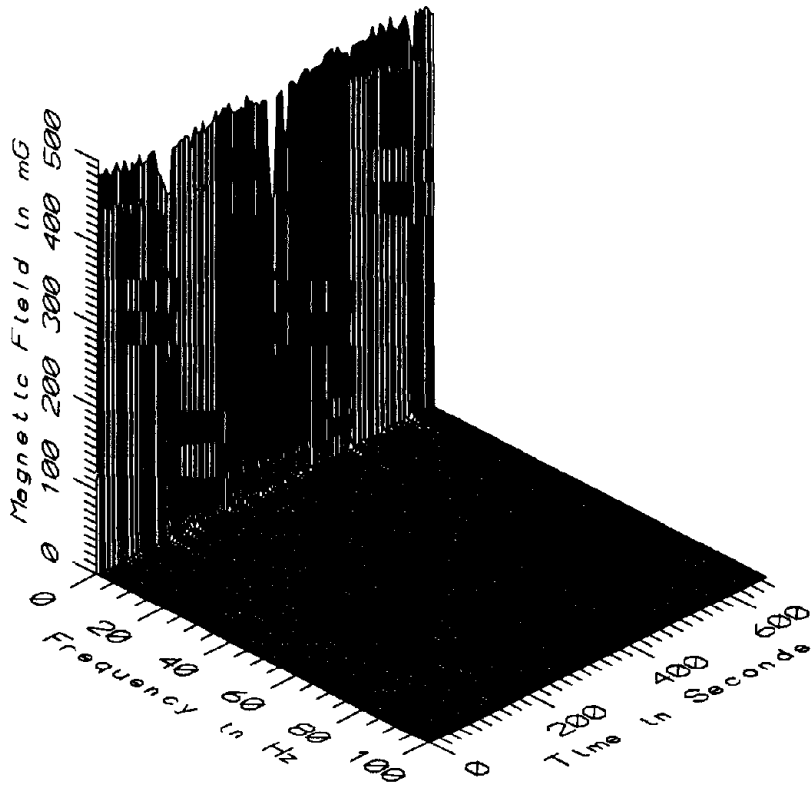

MET054 - 110cm ABOVE GROUND, BENEATH METRORAIL IN UNDERPASS

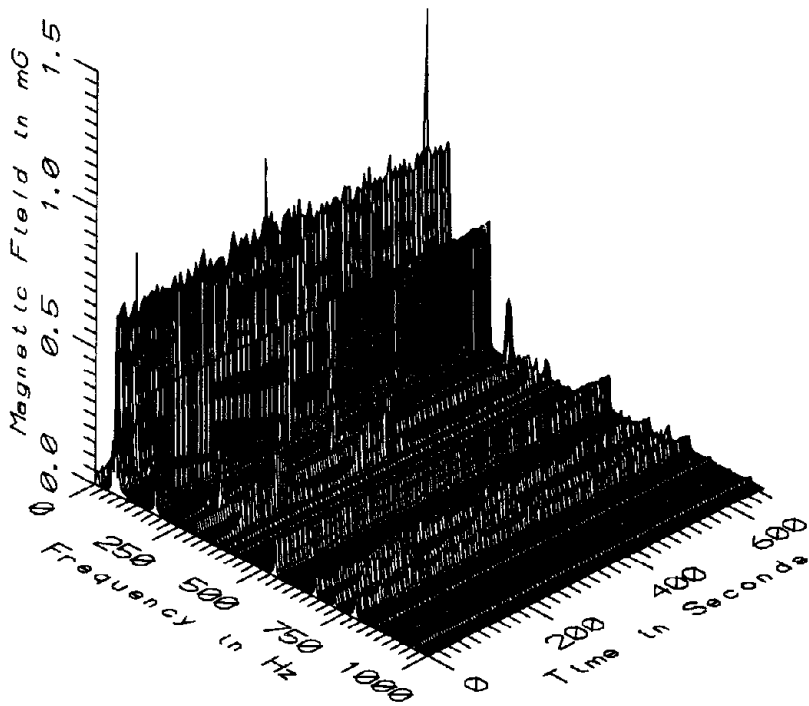

MET054 - 110cm ABOVE GROUND, BENEATH METRORAIL IN UNDERPASS

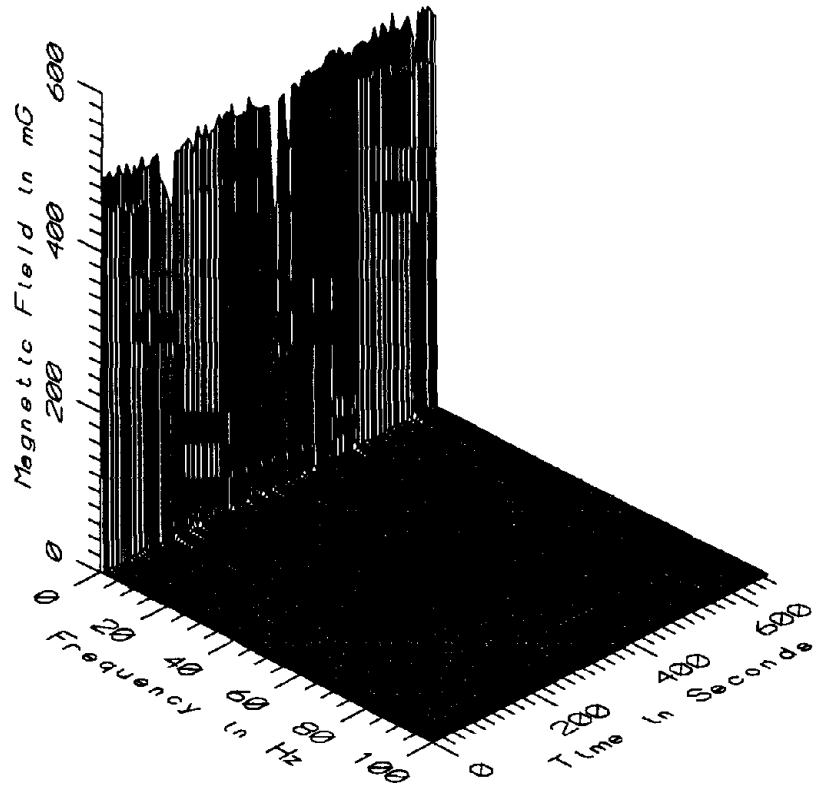

MET054 - 160cm ABOVE GROUND, BENEATH METRORAIL IN UNDERPASS

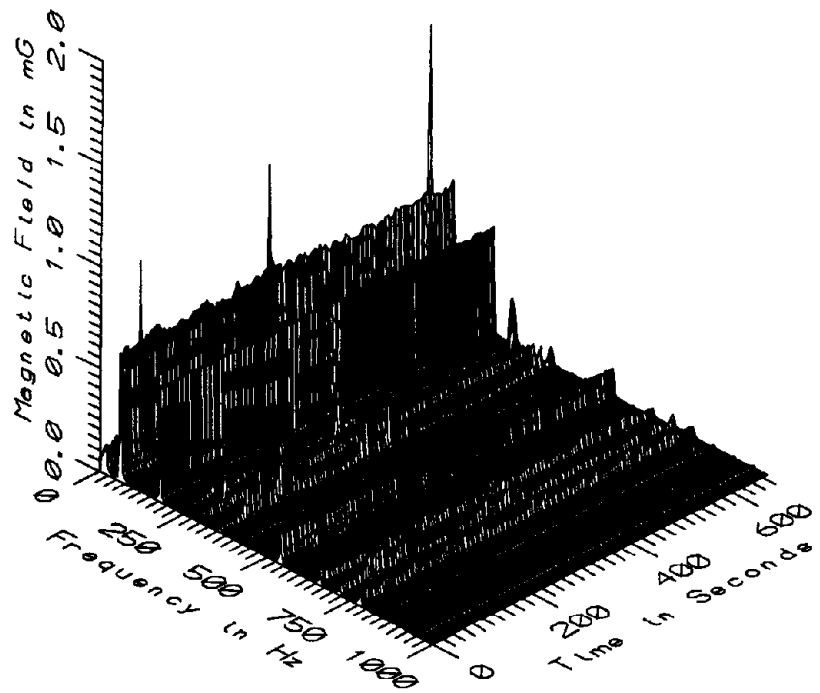

MET054 - 160cm ABOVE GROUND, BENEATH METRORAIL IN UNDERPASS

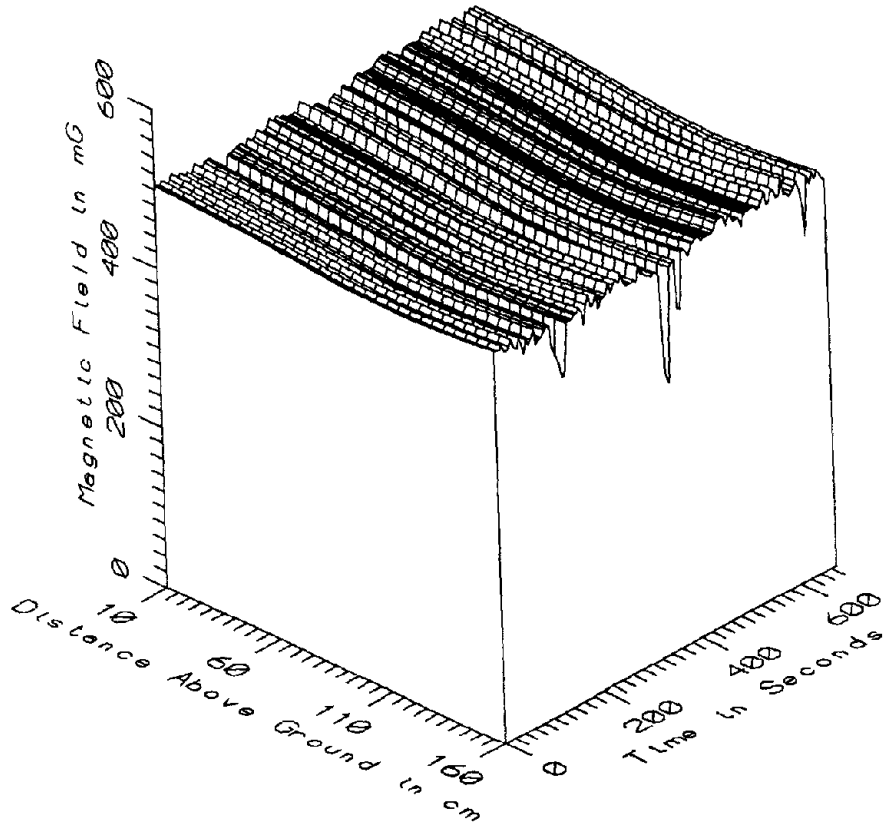

MET054 - BENEATH METRORAIL IN UNDERPASS - STATIC

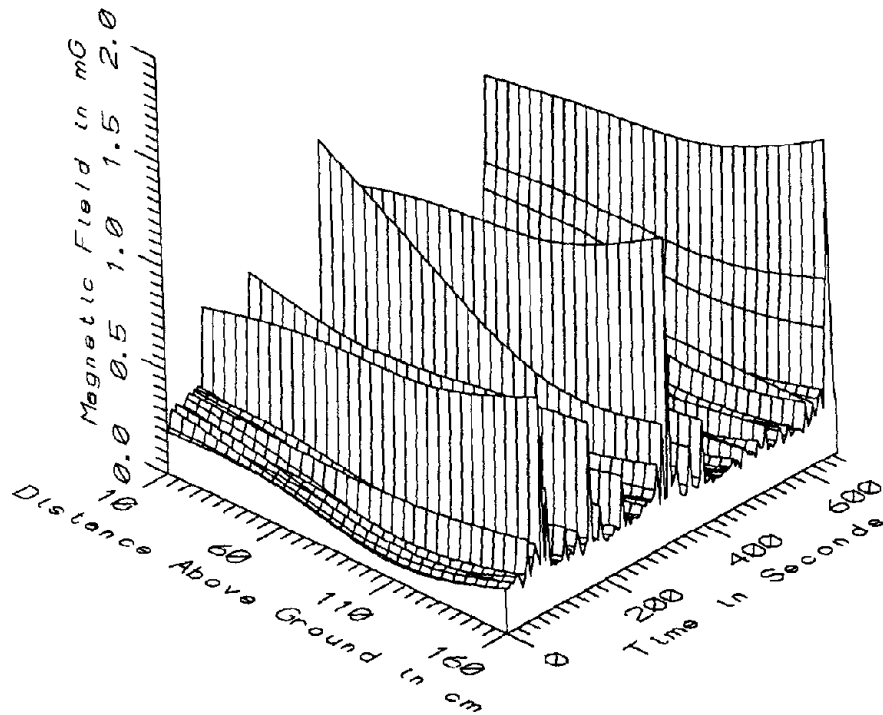

MET054 - BENEATH METRORAIL IN UNDERPASS - LOW FREQ, 5-45Hz

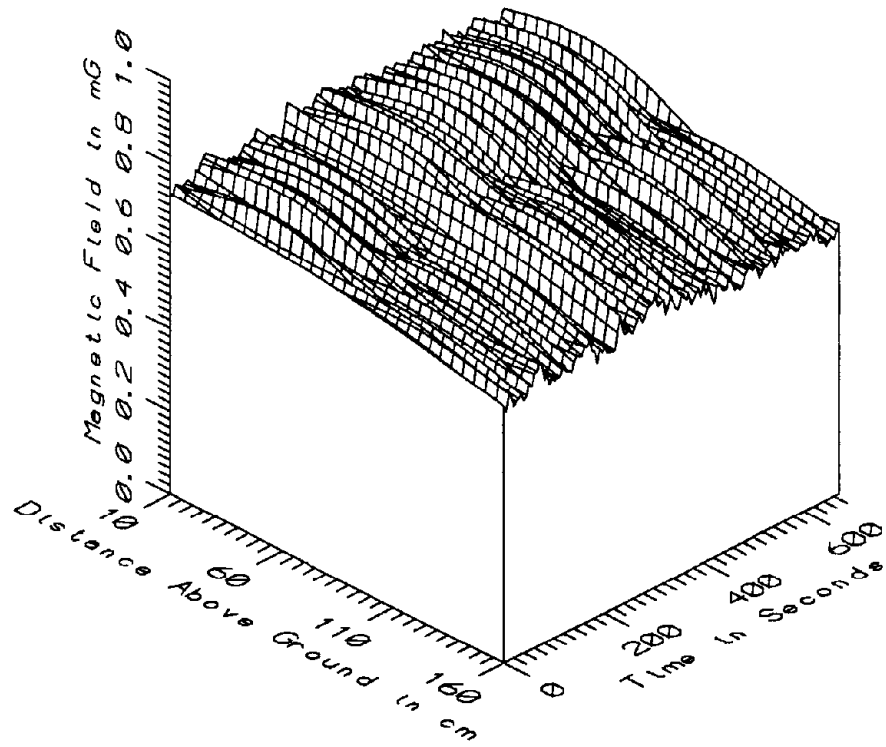

MET054 - BENEATH METRORAIL IN UNDERPASS - POWER FREQ, 50-60Hz

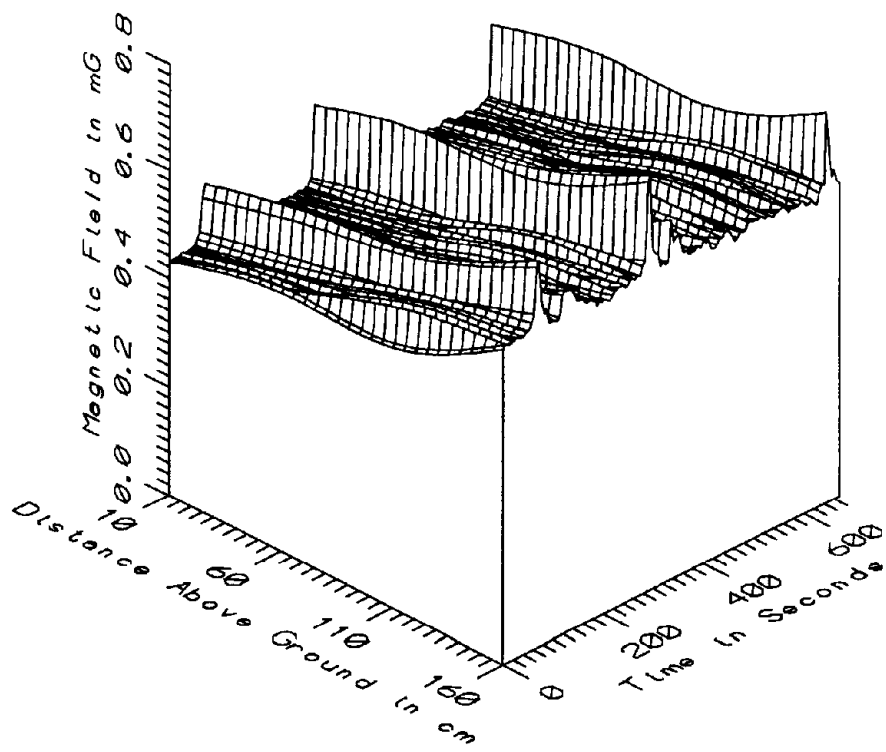

MET054 - BENEATH METRORAIL IN UNDERPASS - POWER HARM, 65-300Hz

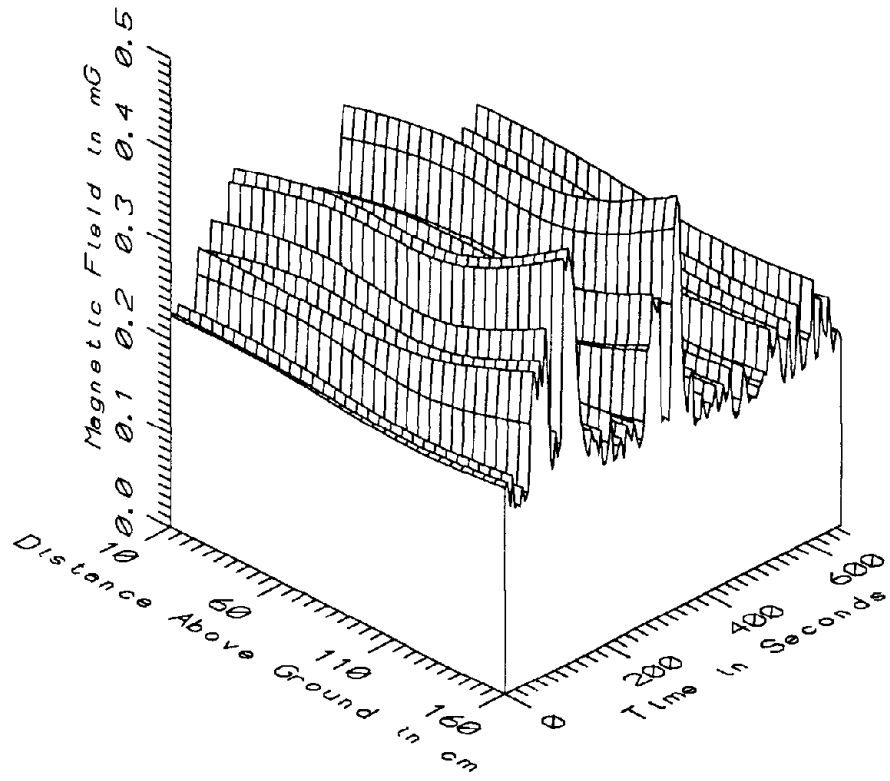

MET054 - BENEATH METRORAIL IN UNDERPASS - HIGH FREQ, 305-2560Hz

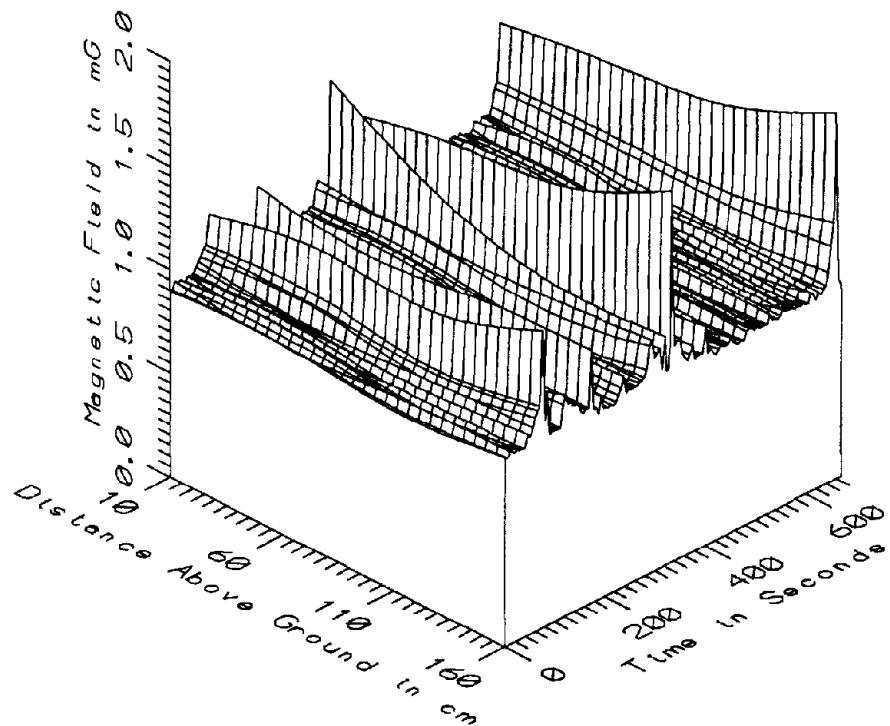

MET054 - BENEATH METRORAIL IN UNDERPASS - ALL FREQ, 5-2560Hz

MET054 - BENEATH METRORAIL AT HIGHWAY UNDERPASS		TOTAL OF 133 SAMPLES				
FREQUENCY BAND	HEIGHT ABOVE GROUND (cm)	MINIMUM MAGNETIC FIELD (mG)	MAXIMUM MAGNETIC FIELD (mG)	AVERAGE MAGNETIC FIELD (mG)	STANDARD DEVIATION (mG)	COEFFICIENT OF VARIATION (%)
STATIC	10	383.81	516.00	496.05	18.52	3.73
	60	353.78	509.88	485.42	21.71	4.47
	110	339.19	498.41	473.48	23.05	4.87
	160	335.90	515.14	483.63	26.39	5.46
5-45HZ LOW FREQ	10	0.19	1.19	0.31	0.15	46.73
	60	0.15	1.15	0.25	0.16	63.70
	110	0.04	1.24	0.16	0.18	115.36
	160	0.17	1.52	0.28	0.20	70.74
50-60HZ PWR FREQ	10	0.70	0.80	0.75	0.02	2.45
	60	0.66	0.83	0.74	0.04	5.09
	110	0.63	0.77	0.69	0.03	4.27
	160	0.60	0.71	0.65	0.02	3.13
65-300HZ PWR HARM	10	0.43	0.59	0.44	0.03	6.05
	60	0.47	0.64	0.49	0.03	5.69
	110	0.48	0.67	0.54	0.03	6.50
	160	0.56	0.77	0.60	0.03	5.50
305-2560HZ HIGH FREQ	10	0.17	0.36	0.22	0.04	18.42
	60	0.17	0.38	0.23	0.05	20.68
	110	0.16	0.38	0.22	0.05	22.60
	160	0.17	0.44	0.24	0.06	26.92
5-2560HZ ALL FREQ	10	0.89	1.52	0.96	0.08	8.73
	60	0.86	1.48	0.96	0.09	9.29
	110	0.83	1.54	0.93	0.10	10.48
	160	0.88	1.78	0.97	0.13	12.94

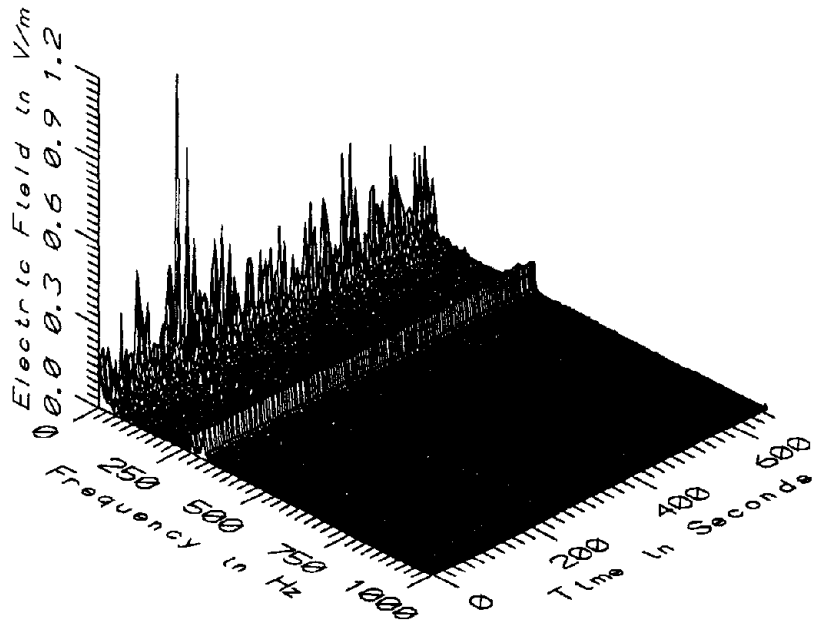

MET054 - ELECTRIC FIELD AT METRORAIL HIGHWAY UNDERPASS



APPENDIX AY

DATASET MET055  
BENEATH METRORAIL AT HIGHWAY UNDERPASS

Measurement Setup Code:      Staff:    12    Reference: -  
   Drawing: A-2

Vehicle Status:                      NA

Measurement Date:                    May 20, 1992

Measurement Time:                    Start:    14:32:30  
   End:        14:33:01

Number of Samples:                    6

Programmed Sample Interval:        5 sec

Actual Sample Interval:              6.2 sec

**Frequency Spectrum Parameters**

<u>Probe Type:</u>	<u>Wideband</u>	<u>Static</u>
Maximum Frequency (Hz)	2560	100
Minimum Frequency (Hz)	5	0
Spectral Bandwidth (Hz)	5	1

Missing Data: No reference probe

Saturated Data: None

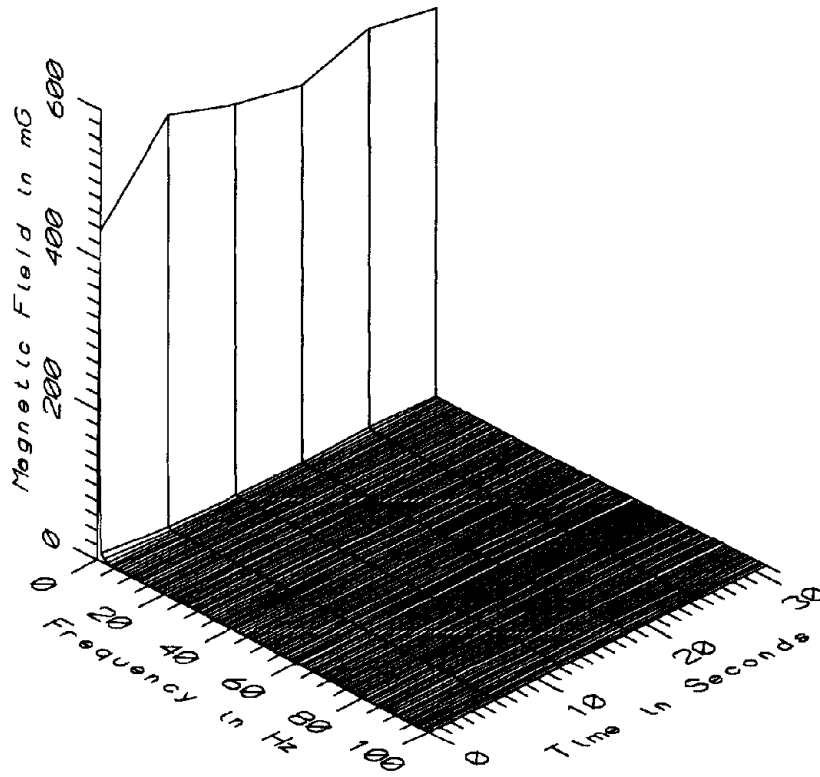

MET055 - 10cm ABOVE GROUND, BENEATH METRORAIL IN UNDERPASS

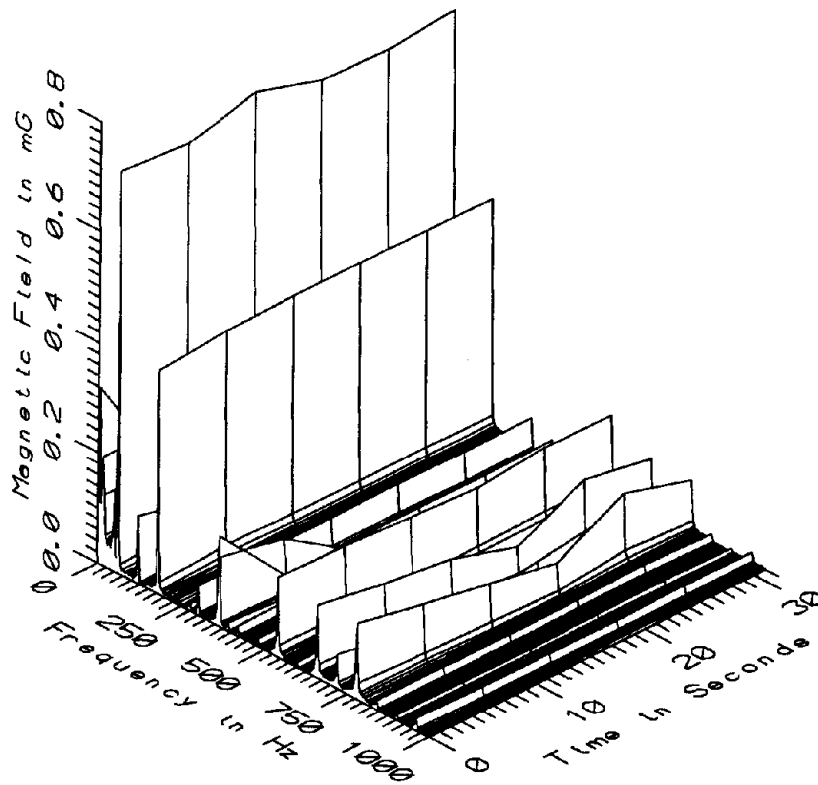

MET055 - 10cm ABOVE GROUND, BENEATH METRORAIL IN UNDERPASS

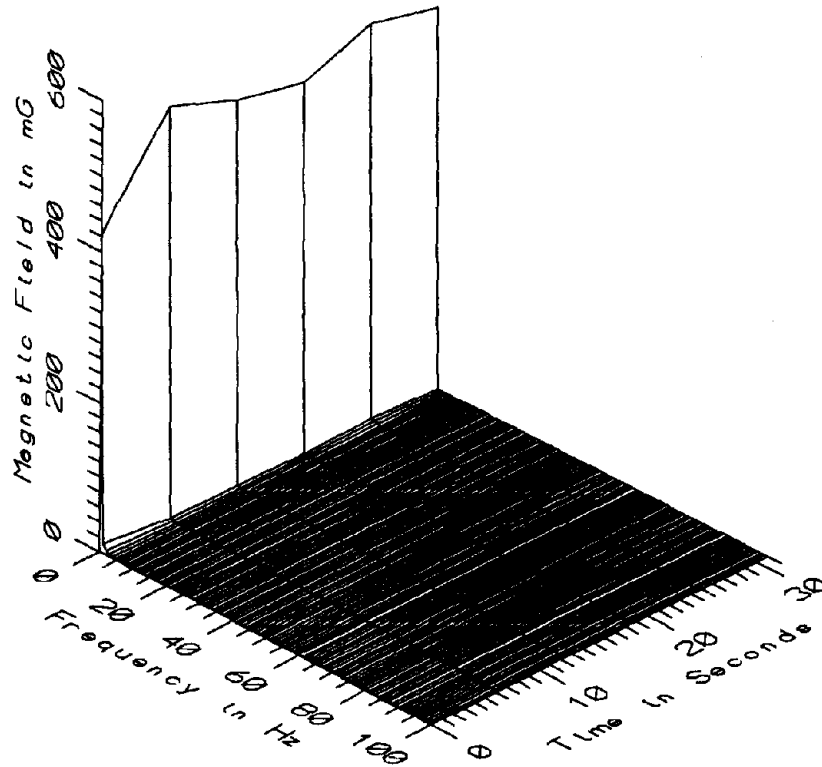

MET055 - 60cm ABOVE GROUND, BENEATH METRORAIL IN UNDERPASS

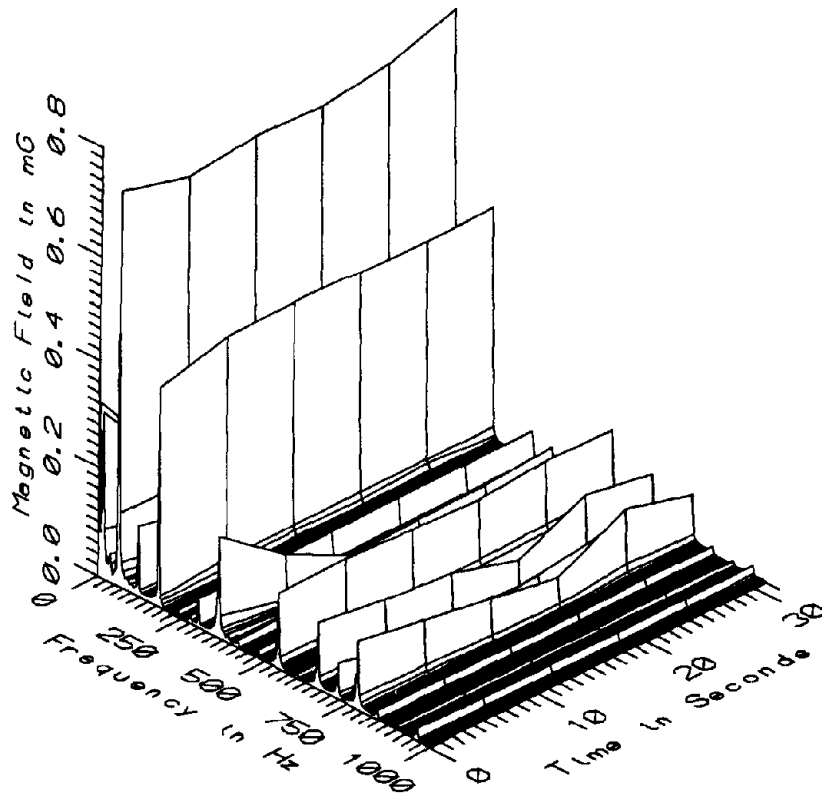

MET055 - 60cm ABOVE GROUND, BENEATH METRORAIL IN UNDERPASS

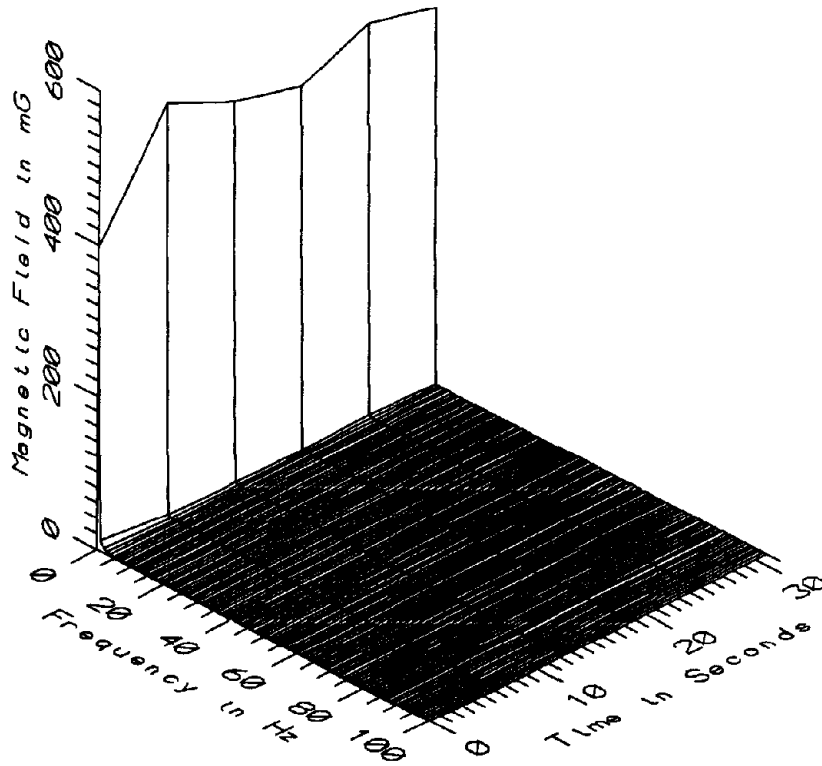

MET055 - 110cm ABOVE GROUND, BENEATH METRORAIL IN UNDERPASS

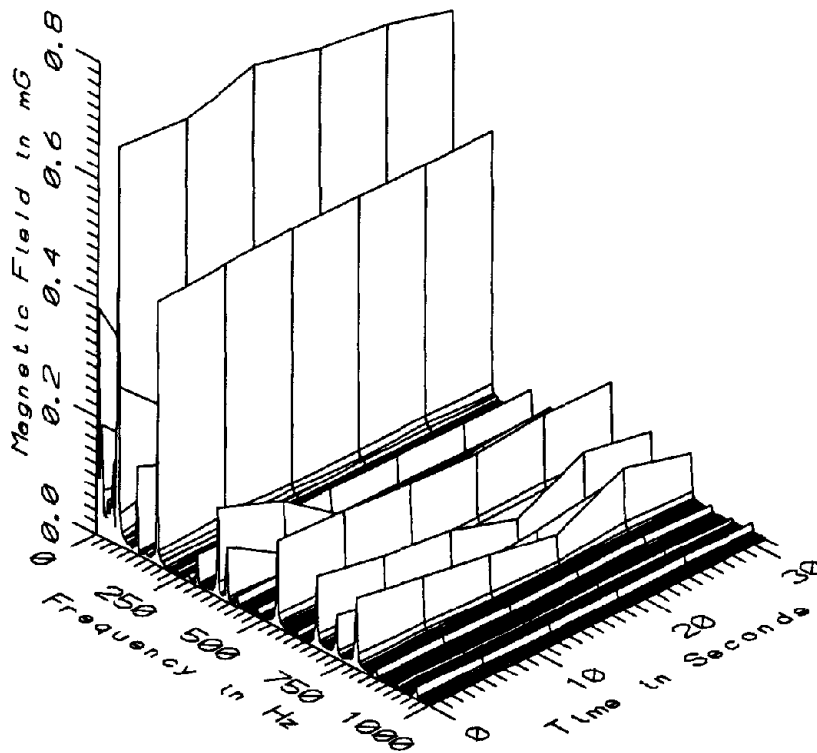

MET055 - 110cm ABOVE GROUND, BENEATH METRORAIL IN UNDERPASS

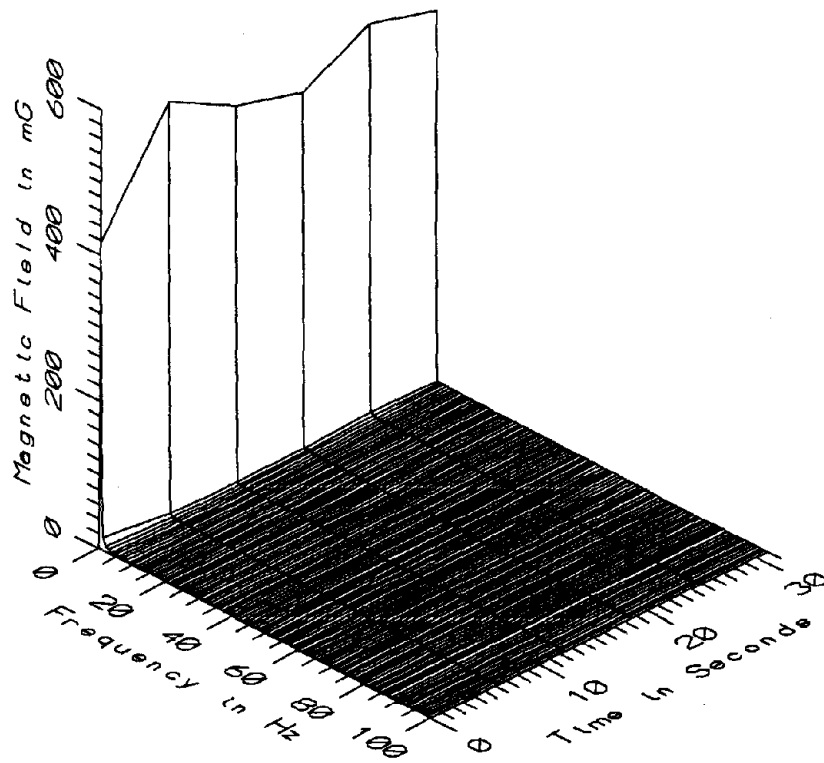

MET055 - 160cm ABOVE GROUND, BENEATH METRORAIL IN UNDERPASS

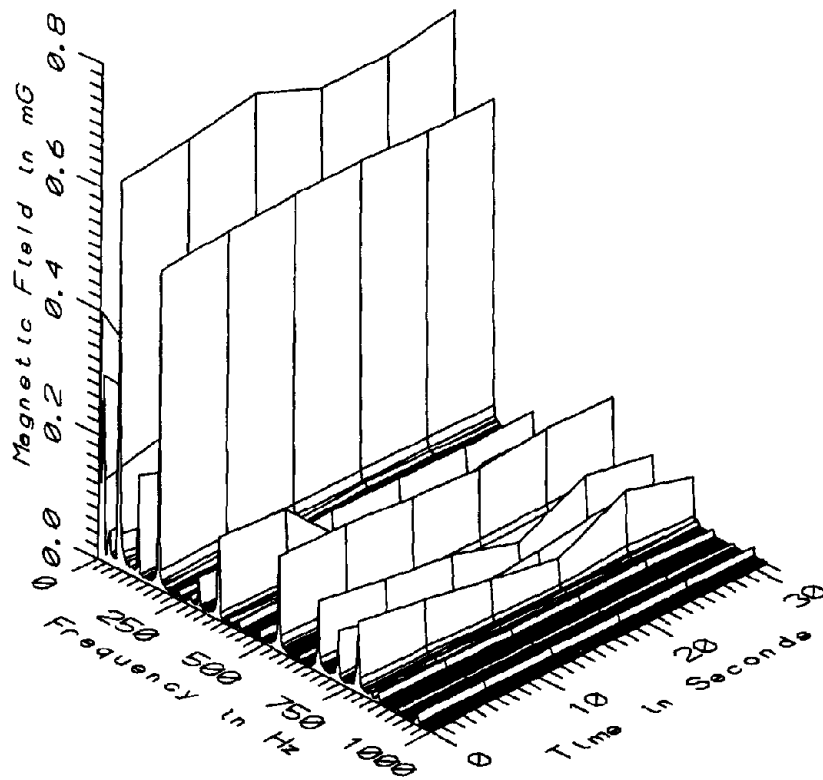

MET055 - 160cm ABOVE GROUND, BENEATH METRORAIL IN UNDERPASS

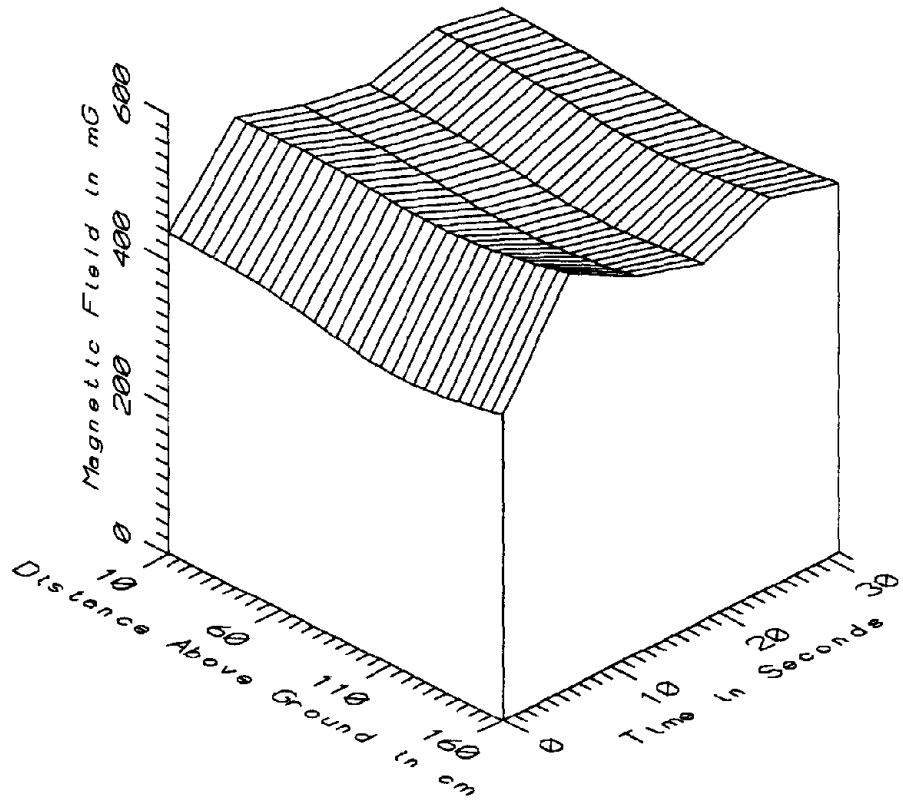

MET055 - BENEATH METRORAIL IN UNDERPASS - STATIC

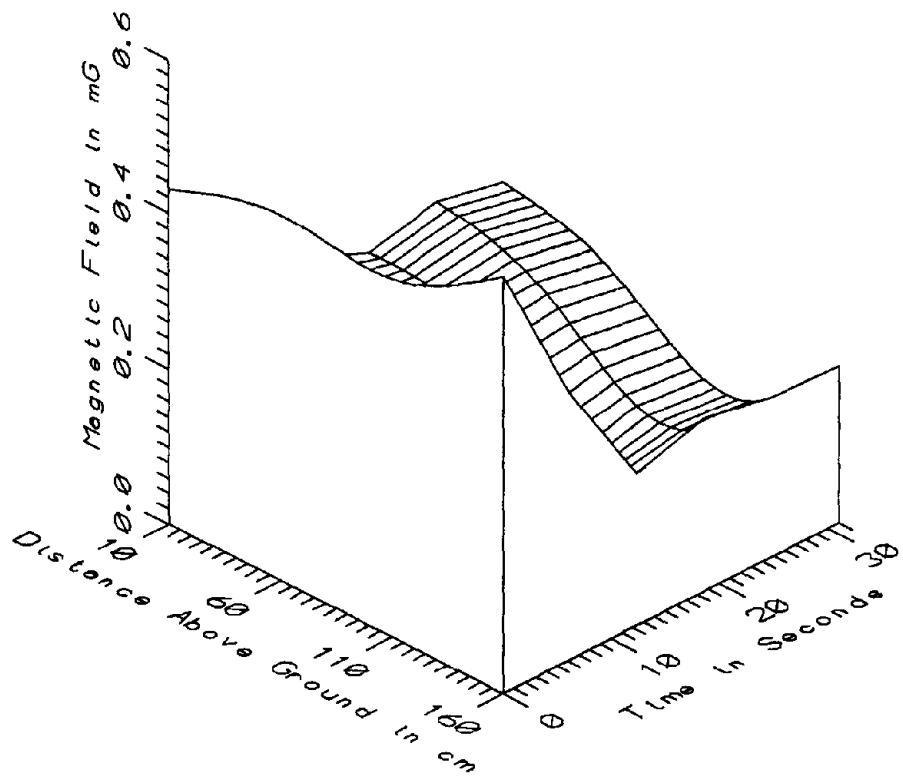

MET055 - BENEATH METRORAIL IN UNDERPASS - LOW FREQ, 5-45Hz

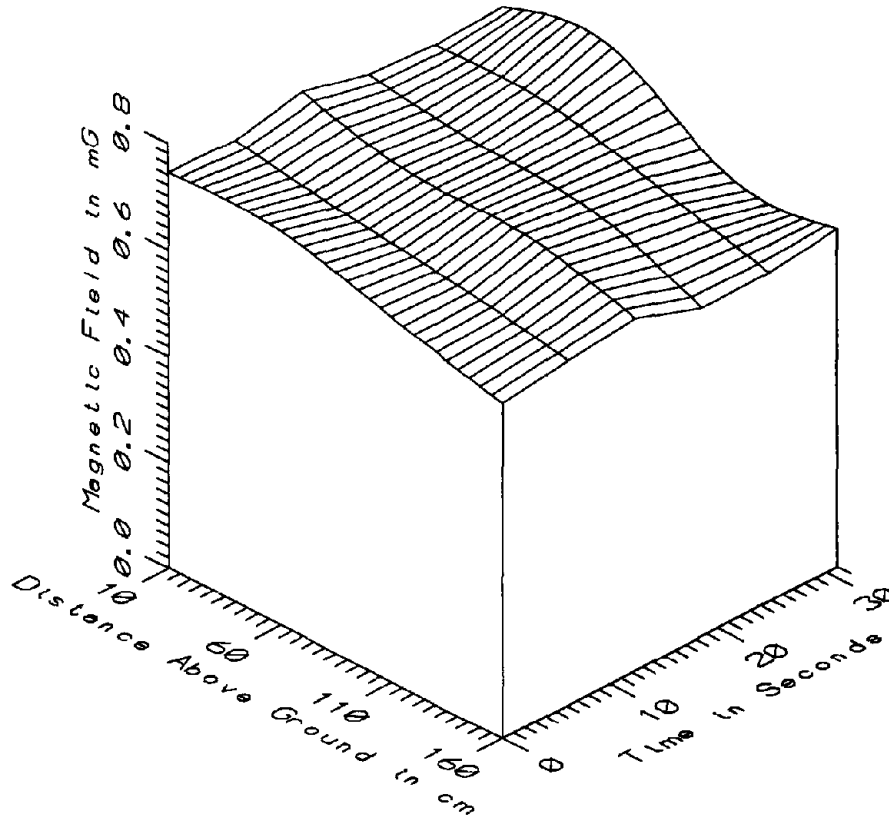

MET055 - BENEATH METRORAIL IN UNDERPASS - POWER FREQ, 50-60Hz

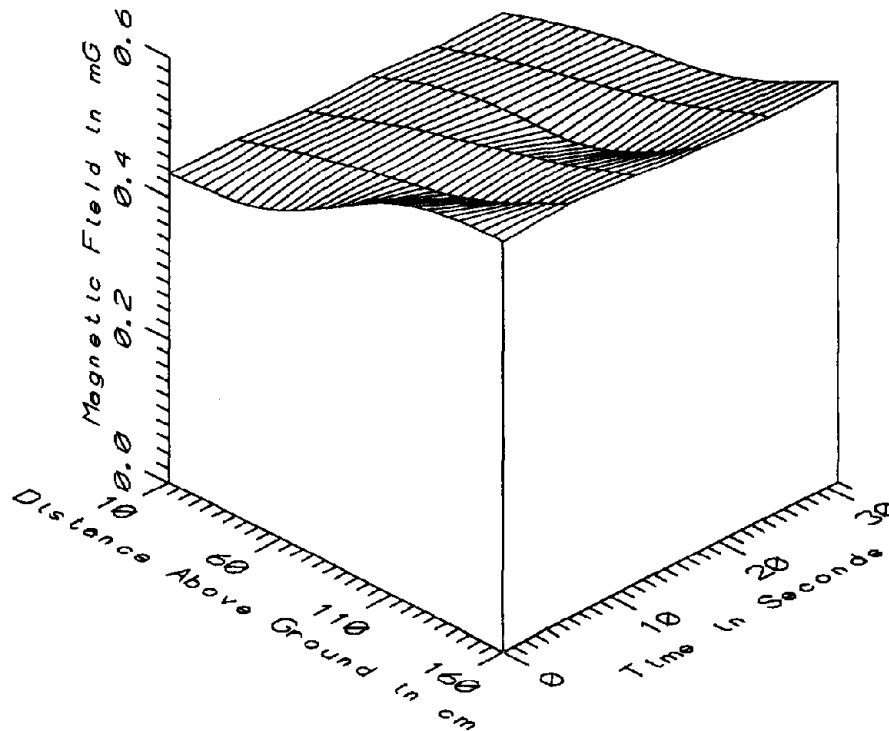

MET055 - BENEATH METRORAIL IN UNDERPASS - POWER HARM, 65-300Hz

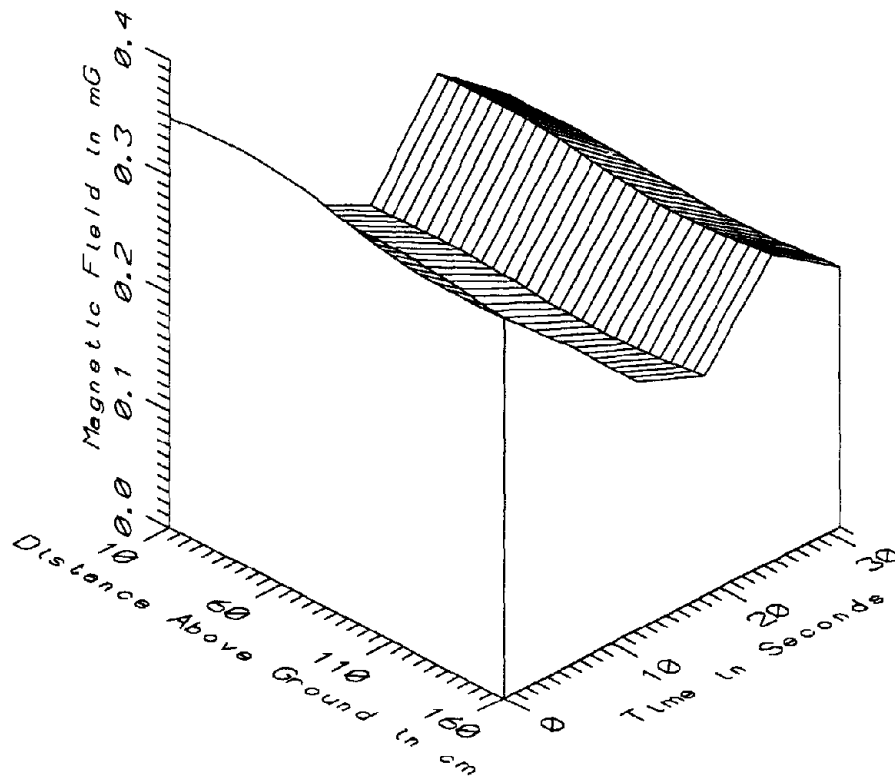

MET055 - BENEATH METRORAIL IN UNDERPASS - HIGH FREQ, 305-2560Hz

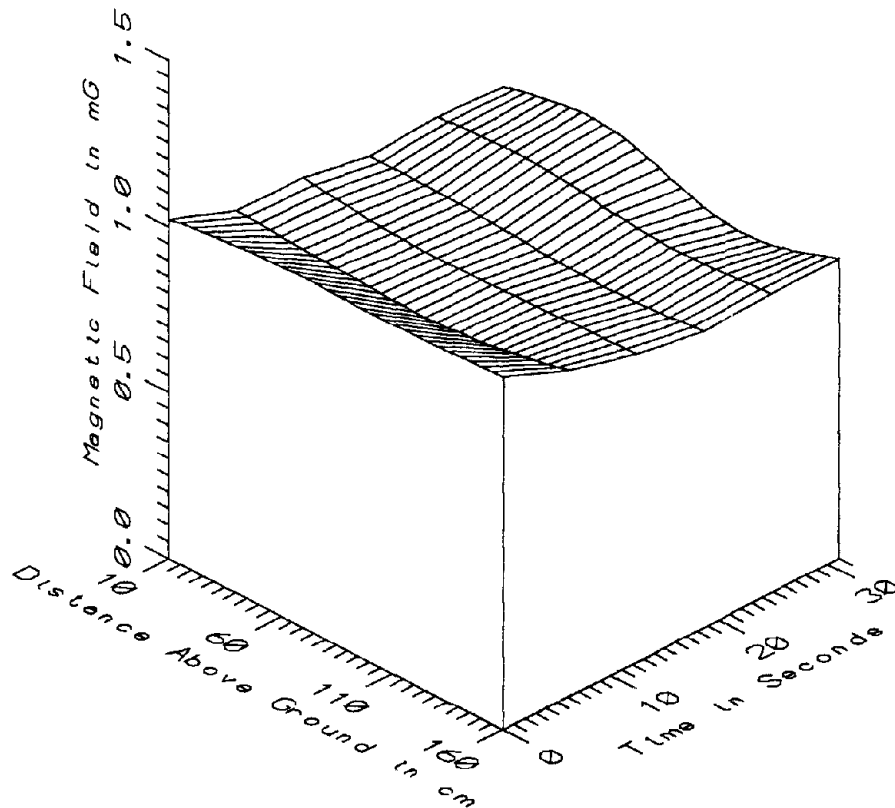

MET055 - BENEATH METRORAIL IN UNDERPASS - ALL FREQ, 5-2560Hz



MET055 - BENEATH METRORAIL AT HIGHWAY UNDERPASS		TOTAL OF 6 SAMPLES				
FREQUENCY BAND	HEIGHT ABOVE GROUND (cm)	MINIMUM MAGNETIC FIELD (mG)	MAXIMUM MAGNETIC FIELD (mG)	AVERAGE MAGNETIC FIELD (mG)	STANDARD DEVIATION (mG)	COEFFICIENT OF VARIATION (%)
STATIC	10	437.31	549.51	508.55	38.57	7.58
	60	423.89	548.08	500.95	42.41	8.47
	110	397.30	540.35	486.62	48.96	10.06
	160	417.78	565.60	503.80	49.89	9.90
5-45Hz LOW FREQ	10	0.22	0.43	0.27	0.08	29.34
	60	0.17	0.47	0.24	0.12	48.17
	110	0.08	0.46	0.18	0.15	84.51
	160	0.20	0.54	0.29	0.14	47.28
50-60Hz PWR FREQ	10	0.73	0.77	0.74	0.01	1.77
	60	0.71	0.77	0.73	0.02	3.13
	110	0.64	0.71	0.68	0.03	3.73
	160	0.62	0.66	0.64	0.02	2.64
65-300Hz PWR HARM	10	0.42	0.44	0.43	0.01	1.34
	60	0.46	0.48	0.47	0.01	1.74
	110	0.49	0.55	0.51	0.02	4.35
	160	0.56	0.58	0.57	0.01	1.25
305-2560Hz HIGH FREQ	10	0.19	0.35	0.25	0.06	22.30
	60	0.19	0.35	0.25	0.06	22.33
	110	0.18	0.33	0.24	0.05	21.27
	160	0.19	0.32	0.25	0.05	19.84
5-2560Hz ALL FREQ	10	0.90	1.02	0.94	0.04	4.67
	60	0.90	1.05	0.94	0.06	5.94
	110	0.84	1.05	0.91	0.07	7.75
	160	0.89	1.06	0.94	0.06	6.77



APPENDIX AZ

DATASET MET056  
ALONG WAYSIDE SOUTH OF SHADY GROVE

Measurement Setup Code:        Staff:     14    Reference: -  
   Drawing:  A-3

Vehicle Status:                 NA

Measurement Date:               May 20, 1992

Measurement Time:               Start:     14:52:42  
   End:        14:56:41

Number of Samples:              15

Programmed Sample Interval:    5 sec

Actual Sample Interval:         17.1 sec

Frequency Spectrum Parameters

<u>Probe Type:</u>	<u>Wideband</u>	<u>Static</u>
Maximum Frequency (Hz)	2560	100
Minimum Frequency (Hz)	5	0
Spectral Bandwidth (Hz)	5	1

Missing Data: No reference probe

Saturated Data: None

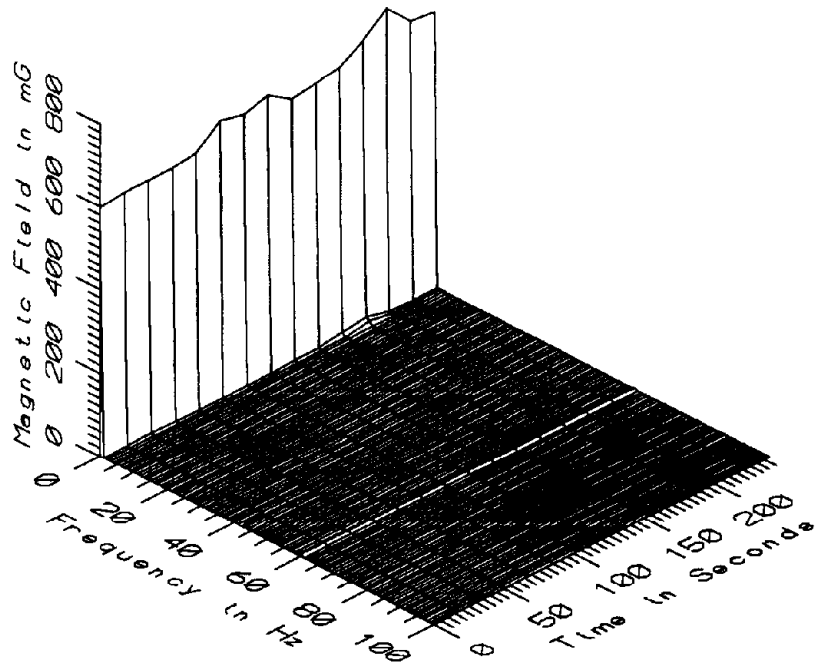

MET056 - 10cm FROM FENCE, WAYSIDE MEASUREMENT, 1M ABOVE GROUND

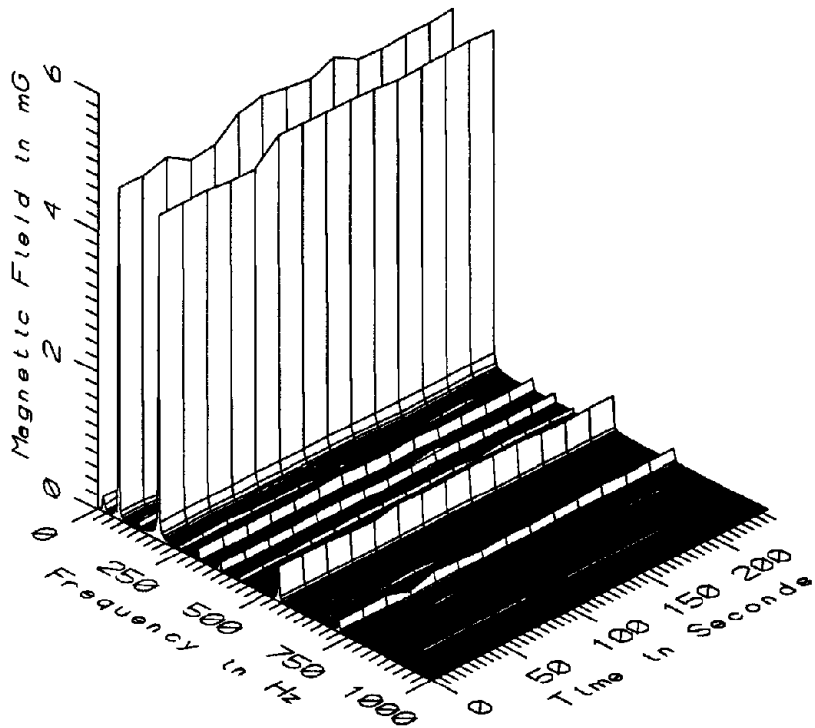

MET056 - 10cm FROM FENCE, WAYSIDE MEASUREMENT, 1M ABOVE GROUND

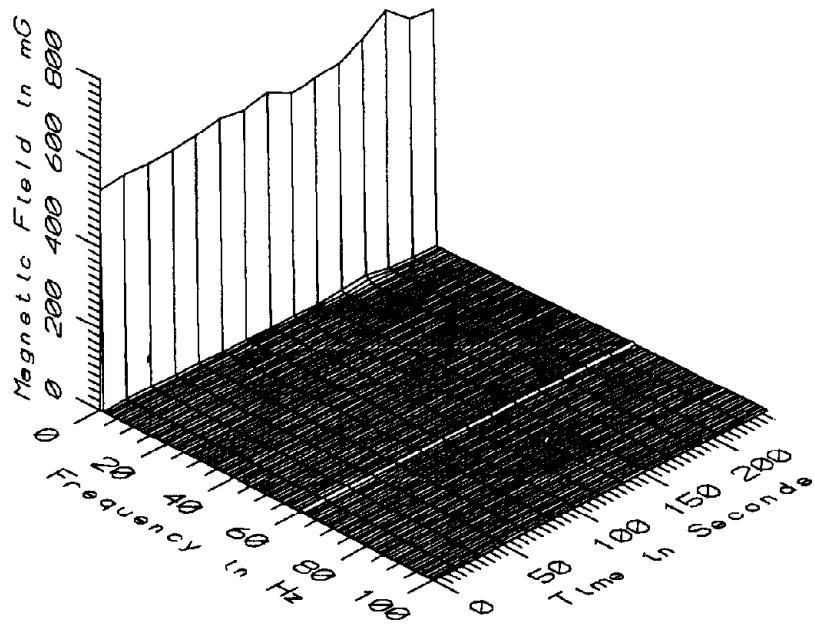

MET056 - 60cm FROM FENCE, WAYSIDE MEASUREMENT, 1M ABOVE GROUND

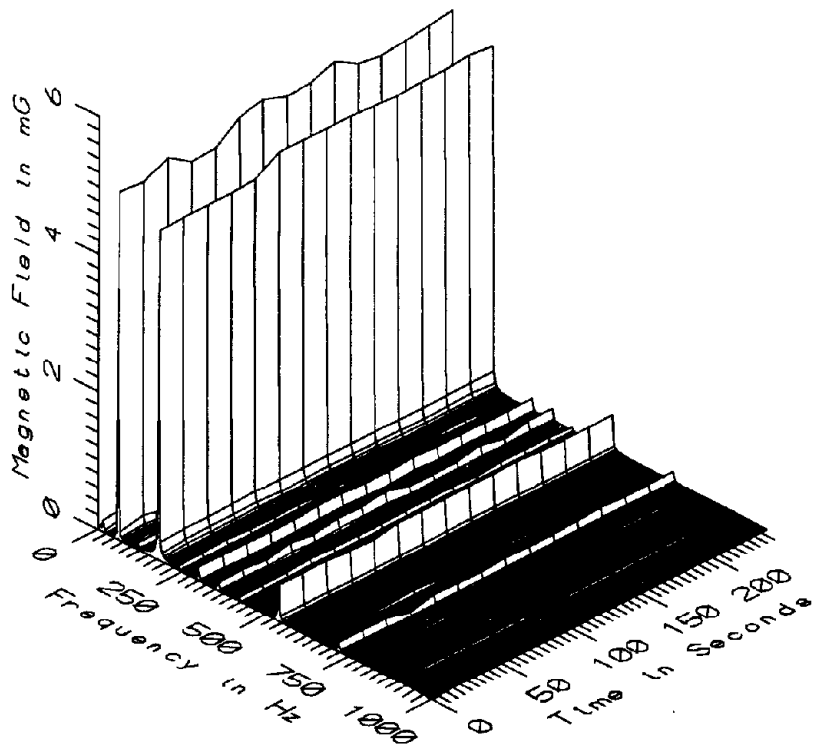

MET056 - 60cm FROM FENCE, WAYSIDE MEASUREMENT, 1M ABOVE GROUND

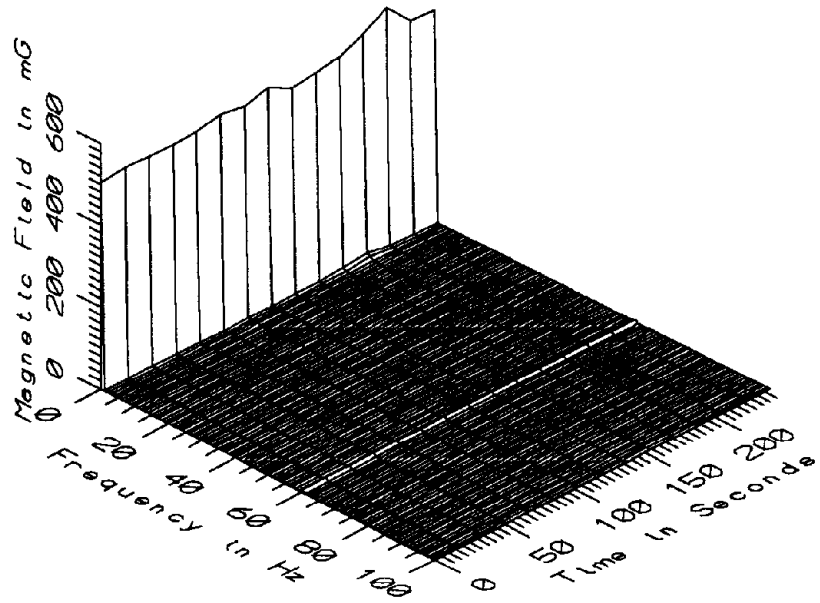

MET056 - 110cm FROM FENCE, WAYSIDE MEASUREMENT, 1M ABOVE GROUND

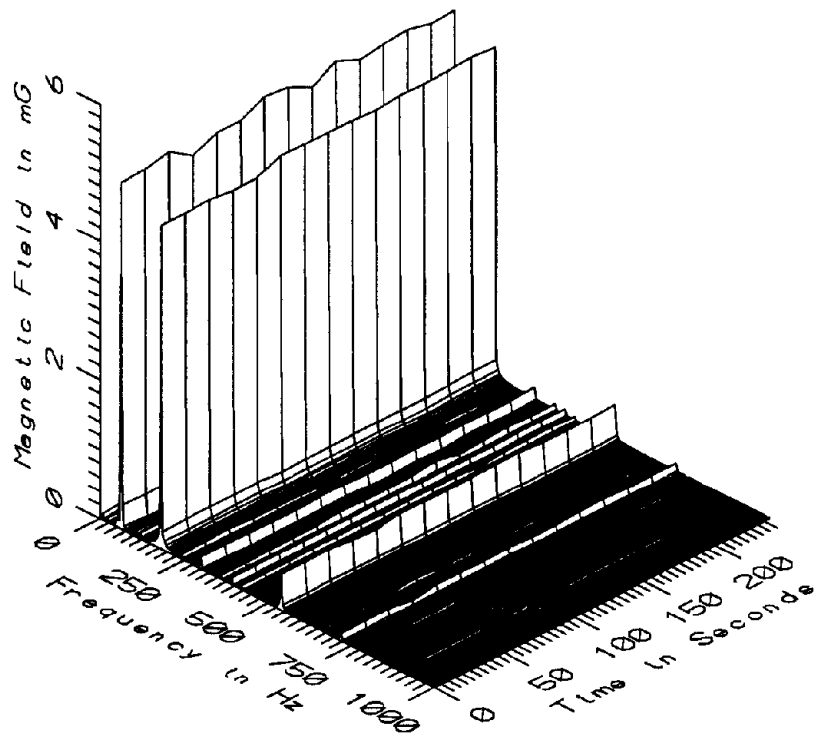

MET056 - 110cm FROM FENCE, WAYSIDE MEASUREMENT, 1M ABOVE GROUND

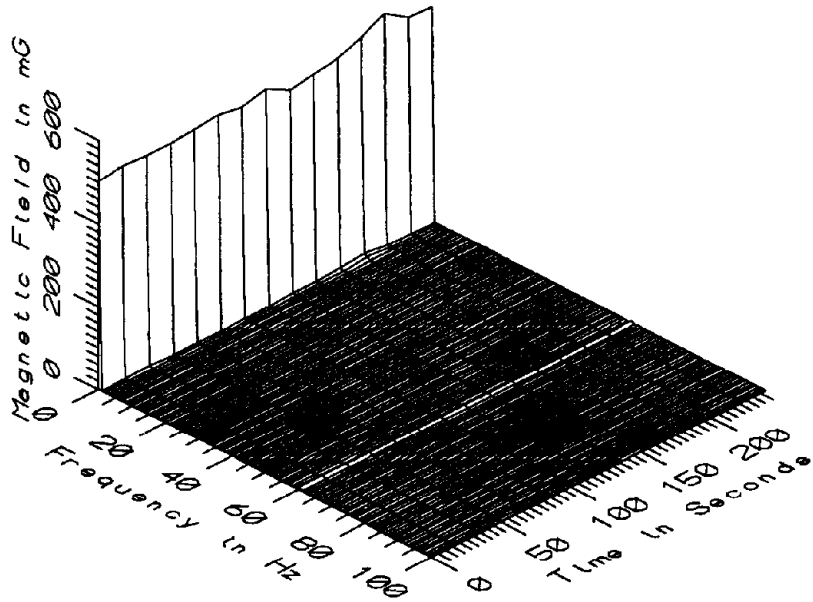

MET056 - 160cm FROM FENCE, WAYSIDE MEASUREMENT, 1M ABOVE GROUND

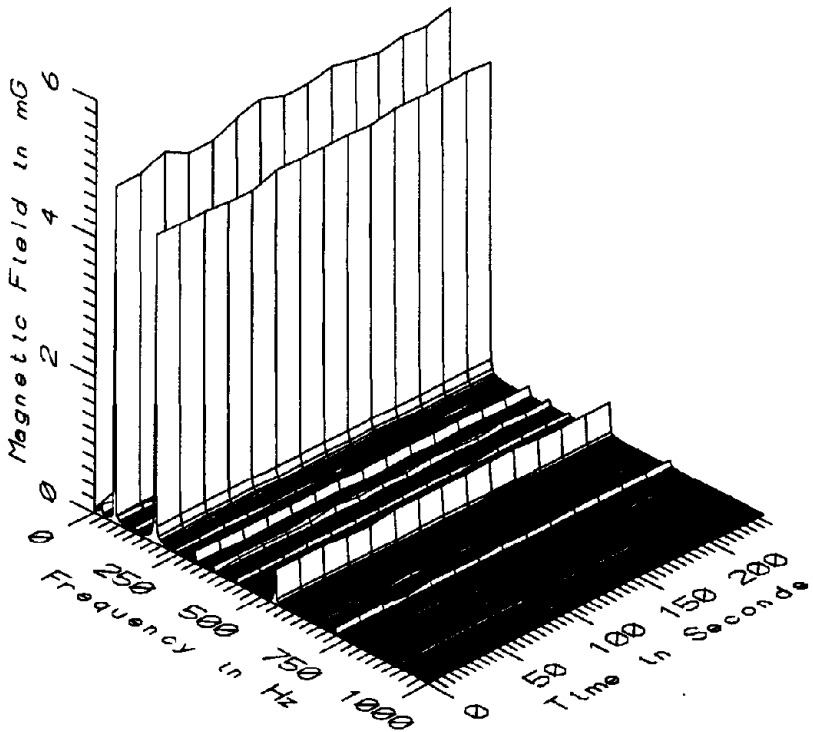

MET056 - 160cm FROM FENCE, WAYSIDE MEASUREMENT, 1M ABOVE GROUND

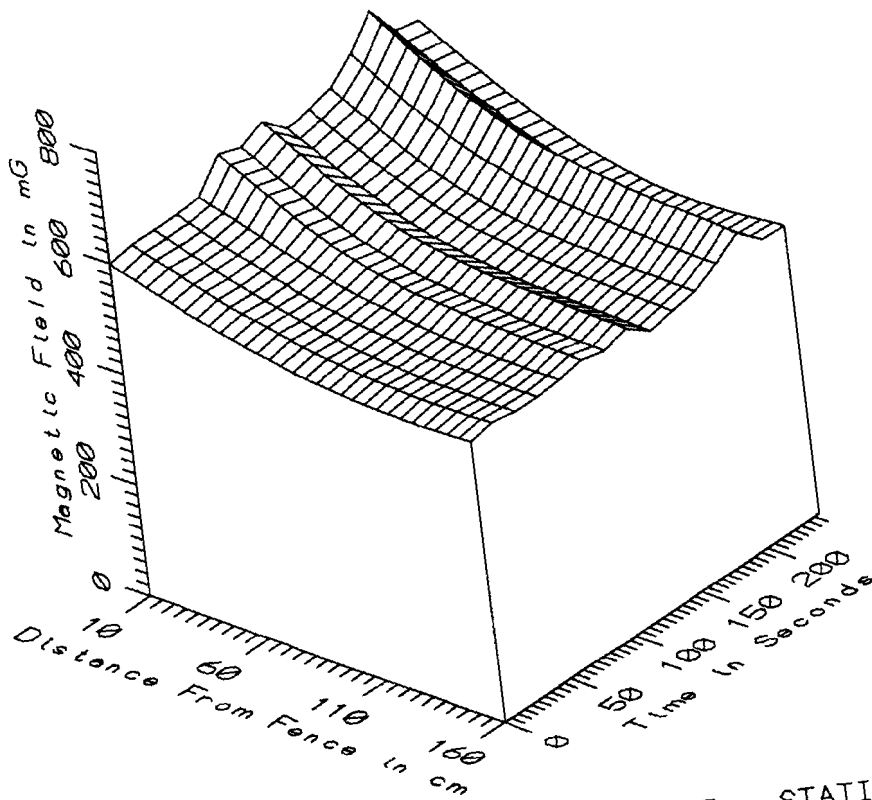

MET056 - WAYSIDE MEASUREMENT, 1M ABOVE GROUND - STATIC

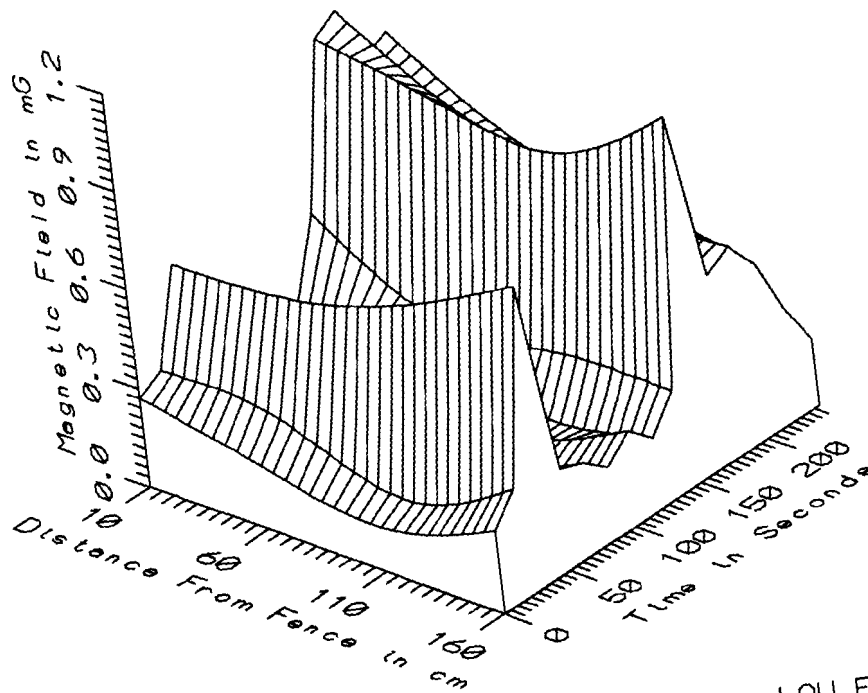

MET056 - WAYSIDE MEASUREMENT, 1M ABOVE GROUND - LOW FREQ, 5-45Hz



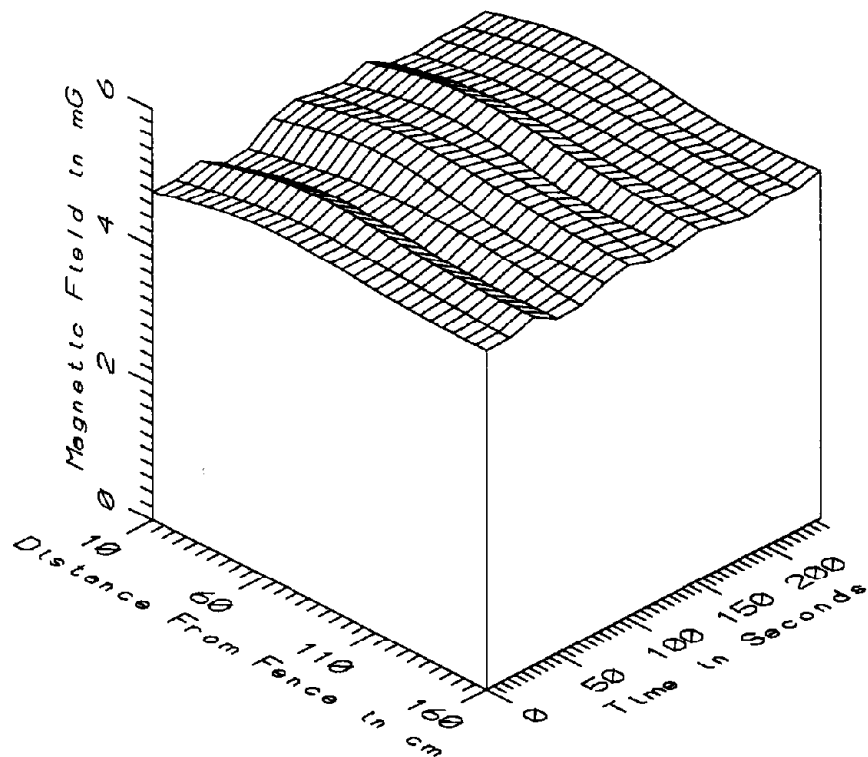

MET056 - WAYSIDE MEASUREMENT, 1M ABOVE GROUND - POWER FREQ, 50-60Hz

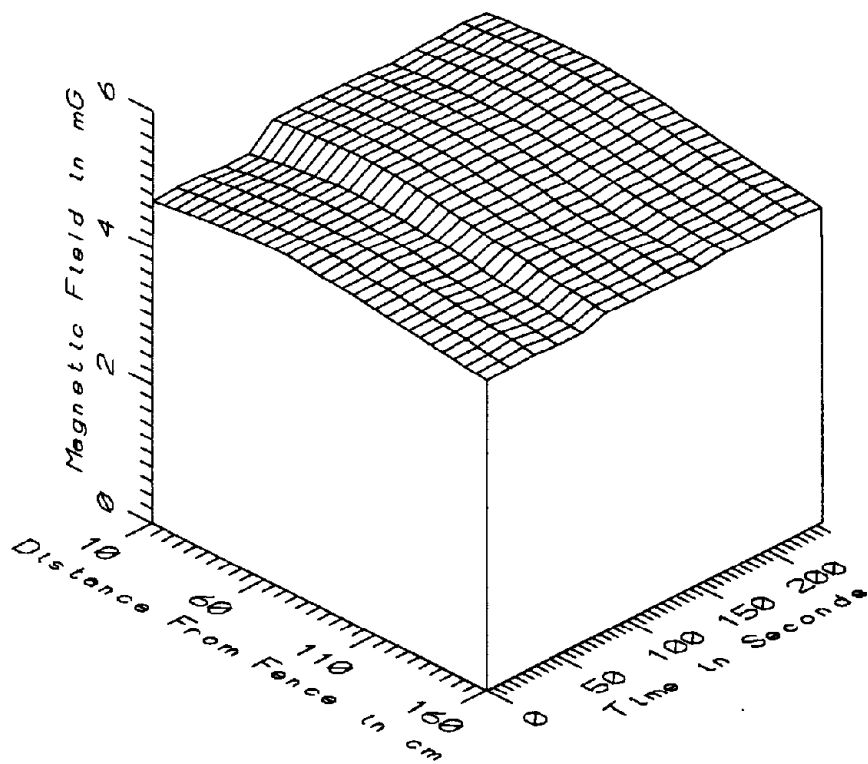

MET056 - WAYSIDE MEASUREMENT, 1M ABOVE GROUND - POWER HARM, 65-300Hz

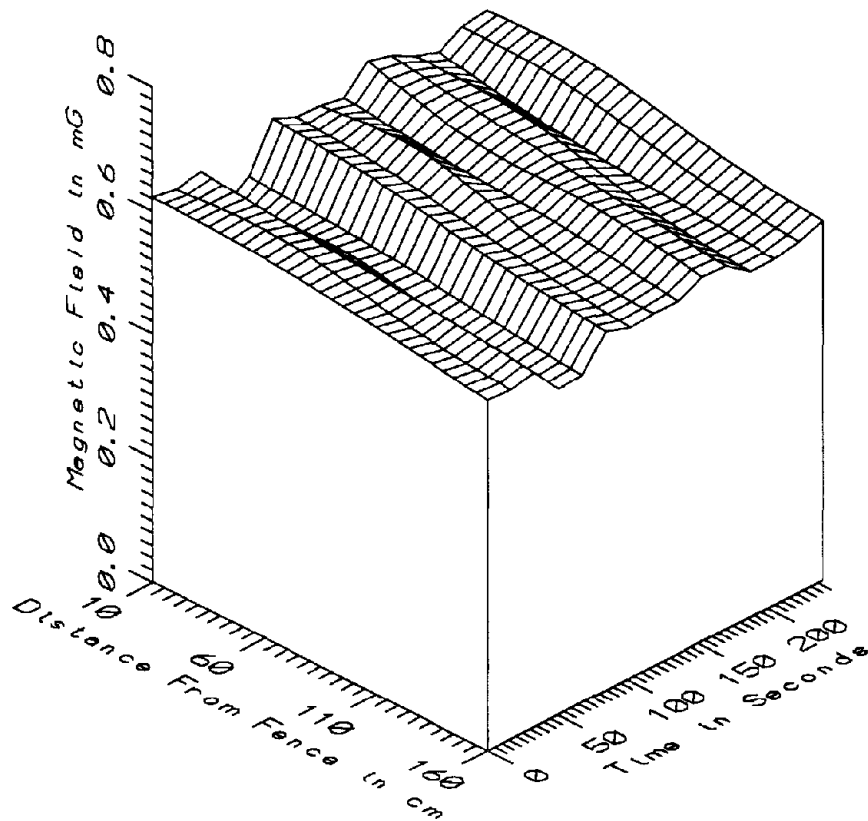

MET056 - WAYSIDE MEASUREMENT, 1M ABOVE GROUND - HIGH FREQ, 305-2560Hz

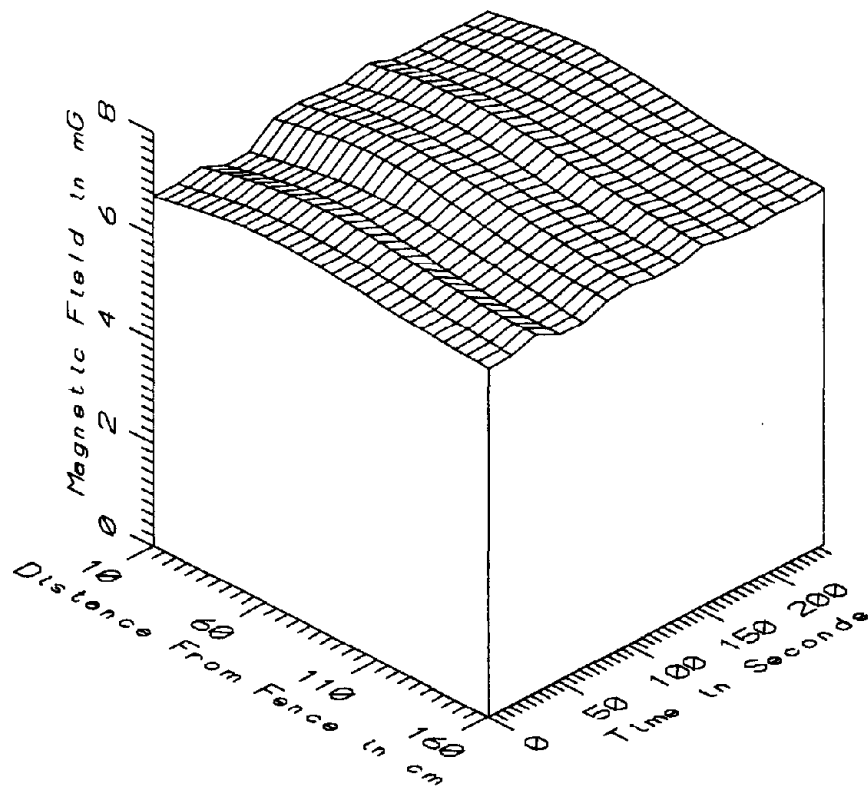

MET056 - WAYSIDE MEASUREMENT, 1M ABOVE GROUND - ALL FREQ, 5-2560Hz

MET056 - WAYSIDE SOUTH OF SHADY GROVE		TOTAL OF 15 SAMPLES				
FREQUENCY BAND	DIST FROM FENCE (cm)	MINIMUM MAGNETIC FIELD (mG)	MAXIMUM MAGNETIC FIELD (mG)	AVERAGE MAGNETIC FIELD (mG)	STANDARD DEVIATION (mG)	COEFFICIENT OF VARIATION (%)
STATIC	10	597.88	733.42	645.14	37.30	5.78
	60	535.13	618.28	556.34	21.25	3.82
	110	499.94	575.45	519.16	18.87	3.63
	160	490.08	560.47	514.22	16.44	3.20
5-45HZ LOW FREQ	10	0.22	1.00	0.48	0.28	58.73
	60	0.19	0.89	0.40	0.25	61.57
	110	0.11	0.87	0.36	0.26	74.35
	160	0.20	1.10	0.43	0.27	62.11
50-60HZ PWR FREQ	10	4.67	5.10	4.90	0.12	2.55
	60	4.99	5.36	5.17	0.11	2.21
	110	4.87	5.21	5.06	0.09	1.72
	160	4.86	5.11	4.99	0.08	1.51
65-300HZ PWR HARM	10	4.68	5.00	4.88	0.13	2.67
	60	4.86	5.10	5.00	0.10	1.92
	110	4.69	4.88	4.80	0.07	1.37
	160	4.48	4.64	4.57	0.05	1.10
305-2560HZ HIGH FREQ	10	0.55	0.67	0.63	0.03	4.84
	60	0.57	0.65	0.61	0.02	3.83
	110	0.54	0.61	0.59	0.02	3.58
	160	0.52	0.59	0.56	0.02	3.29
5-2560HZ ALL FREQ	10	6.64	7.21	6.96	0.18	2.62
	60	7.00	7.45	7.24	0.14	1.99
	110	6.79	7.16	7.02	0.10	1.44
	160	6.65	6.94	6.80	0.09	1.32

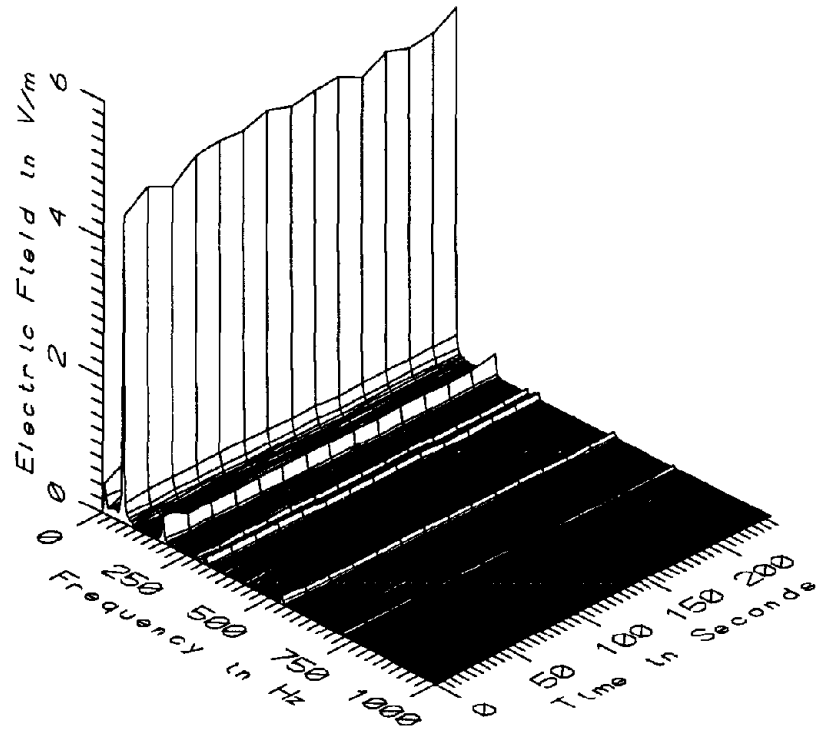

MET056 - ELECTRIC FIELD AT WAYSIDE SOUTH OF SHADY GROVE



