

PB92224674



U. S. Department
of Transportation
**Federal Railroad
Administration**

Safety of High Speed Magnetic Levitation Transportation Systems

Office of Research
and Development
Washington, D.C. 20590

MAGNETIC FIELD TESTING OF THE TR07 MAGLEV VEHICLE AND SYSTEM VOLUME II - APPENDICES

Electric Research and Management, Inc.
P.O. Box 165
State College, PA 16804

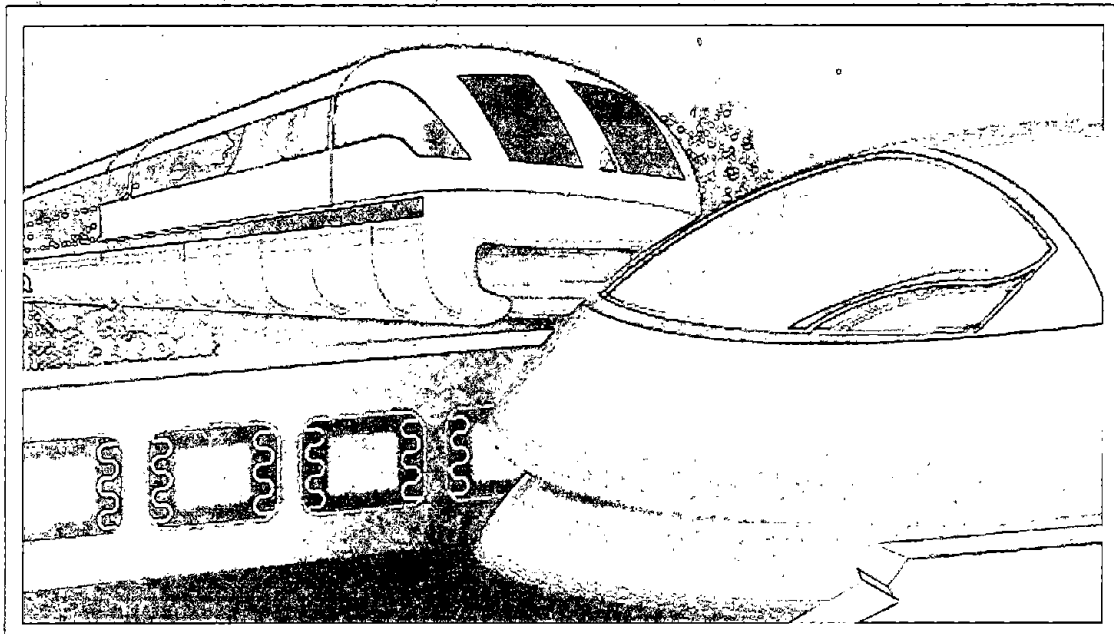

DOT/FRA/ORD-92/09-11
DOT-VNTSC-FRA-92-6-2

Final Report
April 1992

This document is available to the U. S.
public through the National Technical
Information Service, Springfield, VA 22161

REPRODUCED BY
U. S. DEPARTMENT OF COMMERCE
NATIONAL TECHNICAL INFORMATION SERVICE
SPRINGFIELD, VA 22161

NOTICE

This document is disseminated under the sponsorship of the Department of Transportation in the interest of information exchange. The United States Government assumes no liability for its contents or use thereof.

NOTICE

The United States Government does not endorse products or manufacturers. Trade or manufacturers' names appear herein solely because they are considered essential to the object of this report.

NOTICE

In places, this report discusses whether various aspects of the technology that is the subject of this report comply with Federal safety laws and regulations. Those discussions, which reflect the seasoned judgement of commentators qualified in their fields, do not constitute rulings by the Federal Railroad Administration's Office of Safety or its Office of Chief Counsel concerning compliance with the law.

1. Report No. DOT/FRA/ORD-92/09.II	2. PB92-224674	3. Recipient's Catalog No.	
4. Title and Subtitle SAFETY OF HIGH SPEED MAGNETIC LEVITATION TRANSPORTATION SYSTEMS: FINAL REPORT ON MAGNETIC FIELD TESTING OF TR-07 MAGLEV VEHICLE AND SYSTEM VOLUME II - APPENDICES		5. Report Date April 1992	6. Performing Organization Code DTS-701
7. Author(s) Fred Dietrich, David Robertson, George Steiner*		8. Performing Organization Report No. DOT-VNTSC-FRA-92-6.2	
9. Performing Organization Name and Address Electric Research and Management, Inc. P.O. Box 165 State College, PA 16804		10. Work Unit No. (TRAIS) RR293/R2015	11. Contract or Grant No. DTFR-53-91-C-00047
12. Sponsoring Agency Name and Address U.S. Department of Transportation Federal Railroad Administration Office of Research and Development 400 7th St., S.W. Washington, DC 20590		13. Type of Report and Period Covered Final Task Report June 1991-March 1992	
15. Supplementary Notes *Under Contract To: U.S. Department of Transportation Research and Special Programs Administration Volpe National Transportation Systems Center Kendall Square, Cambridge, MA 02142		14. Sponsoring Agency Code FRA RDV-30	
16. Abstract The safety of various magnetically levitated (maglev) and high speed rail (HSR) trains proposed for application in the United States is of direct concern to the Federal Railroad Administration (FRA). The characterization of electric and magnetic fields (EMF) emissions, both steady (dc) and produced by alternating currents (ac) at power frequency (50 Hz in Europe and 60 Hz in the U.S.) and other frequencies in the Extreme Low Frequency (ELF) range (3-3000 Hz), and associated public and worker exposures to EMF, are a growing health and safety concern worldwide. As part of a comprehensive safety assessment of the German TransRapid (TR-07) maglev system undertaken by the FRA, with technical support from the DOT/RSPA Volpe National Transportation System Center (VNTSC), magnetic field measurements were performed by Electric Research and Management, Inc. (ERM) at the Transrapid Test Facility (TVE) in Emsland, Germany in August, 1990. The MultiWave™ magnetic field monitoring system was used to sample, record and store 3 axis dc and ac magnetic fields waveforms simultaneously, at multiple locations: in the TR-07 vehicle (both passenger compartment and operator cab), near the guideway, in the passenger station, and in the vicinity of power supply equipment (inverter building, transformers yard, feeder cables). <u>Volume I-Analysis</u> summarizes the experimental findings and compares results to common home, work, and power lines emissions for selected spectral bands. <u>Volume II-Appendices</u> catalogs and documents detailed magnetic field data files and their specifics (static fields, spectral waveforms, temporal and spatial information) by location.			
17. Key Words Guideway, Wayside, Passenger Compartment, Magnetic Fields, AC and DC, Maglev, ELF, Waveforms, Fourier Analysis		18. Distribution Statement DOCUMENT IS AVAILABLE TO THE PUBLIC THROUGH THE NATIONAL TECHNICAL INFORMATION SERVICE, SPRINGFIELD, VA 22161	
19. Security Classification (of this report) UNCLASSIFIED	20. Security Classification (of this page) UNCLASSIFIED	21. No. of Pages 330	22. Price

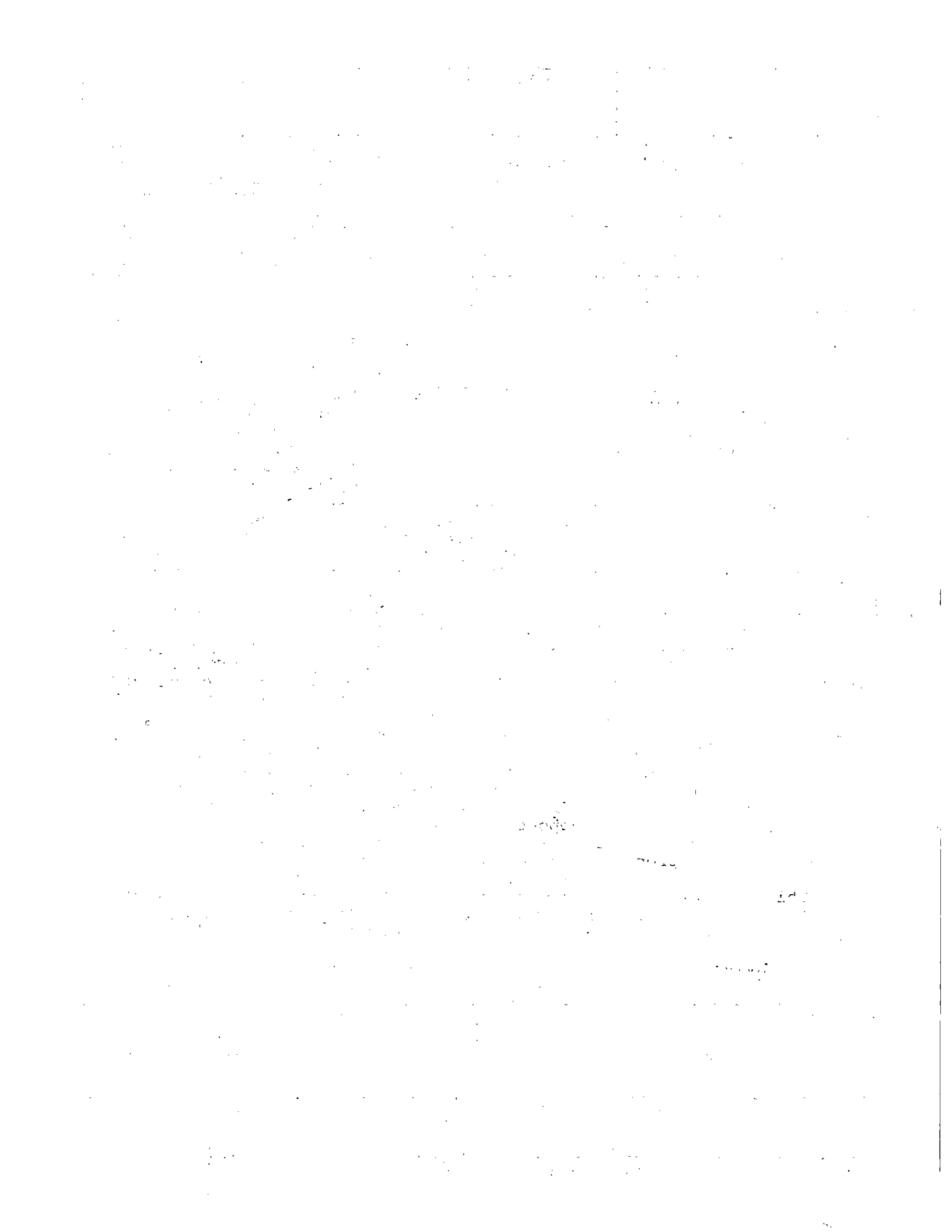

PREFACE

The use of high speed guided ground transportation systems for both urban and intercity travel, including magnetically levitated (maglev) trains, might become a reality within the decade. The first such system in the United States will probably be the Florida Maglev Demonstration Project in Orlando, which is based on the German electromagnetic attraction (EMS) technology represented by the TransRapid (TR-07) prototype. The Federal Railroad Administration (FRA) has the legislative responsibility for the safety of maglev systems in the United States, under the provisions of the Rail Safety Improvement Act of 1988.

One of the emerging environmental health and safety concerns relates to potentially adverse health effects of extreme low frequency (ELF) electric and magnetic fields (EMF) associated with power lines and electrified transportation systems. Magnetic fields at power and harmonics frequencies are of greater public concern, because, unlike electric fields, they are pervasive, penetrate biological tissue, and are more difficult to shield. In addition, maglev and high speed rail (HSR) systems, like most novel and unproven technologies, will undergo more public scrutiny in order to convincingly demonstrate their safety. However, no systematic data on EMF characteristics for existing and advanced electrified transportation systems exists on which to base an assessment of relative emissions profile and associated potential health impacts.

The FRA, with technical and administrative support from the Research and Special Programs Administration (RSPA) Volpe National Transportation Systems Center (VNTSC), has sponsored a comprehensive series of studies and reports addressing the safety issues for candidate high speed rail technologies and systems. The FRA, through VNTSC, has contracted with Electric Research and Management, Inc. (ERM) to measure, characterize, and analyze EMF emissions for both established and advanced rail systems, in order to compile a database on their common and specific EMF signatures, as the basis for comparing them with typical home, work and power line EMF environments. This report on measured levels, spatial, and frequency characteristics of both static (dc) and alternating (ac) magnetic fields associated with the TR-07 maglev, is the first of a series: future reports will describe and discuss EMF characteristics for representative electrical rail systems, existing or proposed for U.S. applications.

This report was prepared by ERM personnel, including Fred Dietrich, Program Manager, William E. Feero, George Steiner, and David Robertson. We acknowledge technical guidance from the FRA sponsor, Mr. Arne Bang, and close interaction with the Technical Monitor, Dr. Aviva Brecher of VNTSC. We also acknowledge experimental design assistance from Dr. Ross Holmstrom, and support from Mr. Robert M. Dorer, Project Leader of the VNTSC Safety Analysis team.



METRIC / ENGLISH CONVERSION FACTORS

ENGLISH TO METRIC

LENGTH (APPROXIMATE)

1 inch (in) = 2.5 centimeters (cm)
 1 foot (ft) = 30 centimeters (cm)
 1 yard (yd) = 0.9 meter (m)
 1 mile (mi) = 1.6 kilometers (km)

AREA (APPROXIMATE)

1 square inch (sq in, in²) = 6.5 square centimeters (cm²)
 1 square foot (sq ft, ft²) = 0.09 square meter (m²)
 1 square yard (sq yd, yd²) = 0.8 square meter (m²)
 1 square mile (sq mi, mi²) = 2.6 square kilometers (km²)
 1 acre = 0.4 hectares (he) = 4,000 square meters (m²)

MASS - WEIGHT (APPROXIMATE)

1 ounce (oz) = 28 grams (gr)
 1 pound (lb) = .45 kilogram (kg)
 1 short ton = 2,000 pounds (lb) = 0.9 tonne (t)

VOLUME (APPROXIMATE)

1 teaspoon (tsp) = 5 milliliters (ml)
 1 tablespoon (tbsp) = 15 milliliters (ml)
 1 fluid ounce (fl oz) = 30 milliliters (ml)
 1 cup (c) = 0.24 liter (l)
 1 pint (pt) = 0.47 liter (l)
 1 quart (qt) = 0.96 liter (l)
 1 gallon (gal) = 3.8 liters (l)
 1 cubic foot (cu ft, ft³) = 0.03 cubic meter (m³)
 1 cubic yard (cu yd, yd³) = 0.76 cubic meter (m³)

TEMPERATURE (EXACT)

$$[(x - 32)(5/9)]^{\circ}\text{F} = y^{\circ}\text{C}$$

METRIC TO ENGLISH

LENGTH (APPROXIMATE)

1 millimeter (mm) = 0.04 inch (in)
 1 centimeter (cm) = 0.4 inch (in)
 1 meter (m) = 3.3 feet (ft)
 1 meter (m) = 1.1 yards (yd)
 1 kilometer (km) = 0.6 mile (mi)

AREA (APPROXIMATE)

1 square centimeter (cm²) = 0.16 square inch (sq in, in²)
 1 square meter (m²) = 1.2 square yards (sq yd, yd²)
 1 square kilometer (km²) = 0.4 square mile (sq mi, mi²)
 1 hectare (he) = 10,000 square meters (m²) = 2.5 acres

MASS - WEIGHT (APPROXIMATE)

1 gram (gr) = 0.036 ounce (oz)
 1 kilogram (kg) = 2.2 pounds (lb)
 1 tonne (t) = 1,000 kilograms (kg) = 1.1 short tons

VOLUME (APPROXIMATE)

1 milliliter (ml) = 0.03 fluid ounce (fl oz)
 1 liter (l) = 2.1 pints (pt)
 1 liter (l) = 1.06 quarts (qt)
 1 liter (l) = 0.26 gallon (gal)
 1 cubic meter (m³) = 36 cubic feet (cu ft, ft³)
 1 cubic meter (m³) = 1.3 cubic yards (cu yd, yd³)

TEMPERATURE (EXACT)

$$[(9/5)y + 32]^{\circ}\text{C} = x^{\circ}\text{F}$$

QUICK INCH-CENTIMETER LENGTH CONVERSION

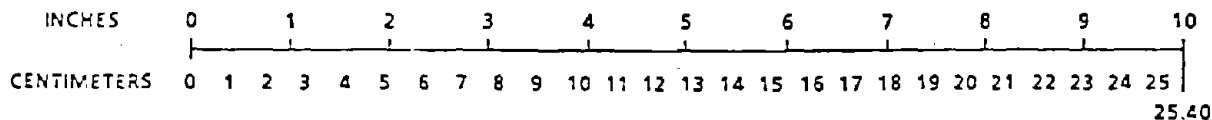

QUICK FAHRENHEIT-CELSIUS TEMPERATURE CONVERSION

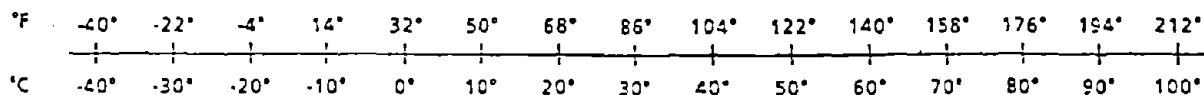

For more exact and/or other conversion factors, see NBS Miscellaneous Publication 286, Units of Weights and Measures. Price \$2.50. SD Catalog No. C13 10 286.



TABLE OF CONTENTS

<u>VOLUME I</u>	<u>PAGE</u>
1.0 EXECUTIVE SUMMARY	1-1
1.1 Background	1-1
1.2 Organizing Electromagnetic Data	1-2
1.3 Findings	1-3
1.4 Comparison of TR07 Fields to Other Environmental Magnetic Fields	1-5
1.5 Comparison of TR07 Fields to Existing Standards	1-8
2.0 OVERVIEW	2-1
2.1 Background	2-1
2.2 An Approach to Organizing Electromagnetic Data	2-3
2.3 Report Organization	2-6
2.4 Repetitive Waveform Data	2-7
2.5 Analysis Method for Repetitive Field Waveforms	2-11
3.0 ONBOARD VEHICLE MEASUREMENTS	3-1
3.1 Measurement Locations	3-1
3.2 Field Levels in the Passenger Areas	3-1
3.2.1 Time-Varying Fields	3-1
3.2.2 Static Fields	3-11
3.2.3 Summary Data	3-14
3.3 Field Levels in the Engineer's Area	3-25
3.4 Other Onboard Measurements	3-28
3.5 Comparison with Other Data	3-38
4.0 MEASUREMENTS ALONG THE GUIDEWAY	4-1
4.1 Measurement Locations	4-1
4.2 AC Field Measurements	4-4
4.3 Static Field Measurements	4-11
4.4 Summary Data	4-11
4.5 Special Test of Levitating Vehicle	4-17
4.6 Comparison with Other Data	4-24
5.0 MEASUREMENTS AT THE PASSENGER STATION	5-1
5.1 Measurement Locations	5-1
5.2 Time-Varying Magnetic Fields	5-1
5.3 Static Magnetic Fields	5-3
5.4 Comparison with Other Data	5-3

TABLE OF CONTENTS (CONT'D)

	<u>PAGE</u>
6.0 MEASUREMENTS NEAR POWER SUPPLY EQUIPMENT	6-1
6.1 Measurement Locations	6-1
6.2 Transformer Yard	6-3
6.3 Braking Resistor Bank	6-10
6.4 Inverter Building	6-14
6.5 Feeder Cables	6-20
7.0 CONCLUSIONS	7-1
7.1 Summary of Transrapid Field Levels	7-1
7.2 Environmental Magnetic Field Levels	7-3
7.3 Comparison of Transrapid Fields to Other Environmental Magnetic Fields	7-7
7.4 Comparison of Transrapid Fields to Existing Standards	7-21
8.0 REFERENCES	8-1

VOLUME II

APPENDIX TITLE

A	Guide to Appended Data
B	Data Set TR7001 - Vehicle Passenger Section, Window Seat, Mid Car
C	Data Set TR7002 - Vehicle Passenger Section, Window Seat, Mid Car
D	Data Set TR7003 - Vehicle Passenger Section, Aisle Seat, Mid Car
E	Data Set TR7008 - Vehicle Passenger Section, Window Seat, Last Row
F	Data Set TR7009 - VIP Passenger Section, At Seat, Rear Car
G	Data Set TR7010 - Vehicle Engineer's Compartment, At Seat, Rear Car
H	Data Set TR7011 - Vehicle Passenger Section, Lateral Profile at Floor Level, Mid Car

APPENDIX TITLE

I	Data Set TR7012 - Lateral Profile Beneath the High Steel Guideway
J	Data Set TR7013 - Lateral Profile Beneath the High Steel Guideway
K	Data Set TR7014 - Lateral Profile Beneath the High Steel Guideway
L	Data Set TR7015 - Lateral Profile Beneath the High Steel Guideway
M	Data Set TR7017 - Lateral Profile Beneath the High Steel Guideway
N	Data Set TR7018 - Lateral Profile Beneath the High Steel Guideway
O	Data Set TR7019 - Lateral Profile Beneath the Low Concrete Guideway
P	Data Set TR7020 - Lateral Profile at the Passenger Station
Q	Data Set TR7021 - Lateral Profile at the Passenger Station
R	Data Set TR7022 - Measurements Near the Transformer Yard
S	Data Set TR7023 - Measurements Near the Braking Resistor Banks
T	Data Set TR7024 - Measurements Near the Braking Resistor Banks
U	Data Set TR7025 - Lateral Profile Beneath the Low Concrete Guideway With the Vehicle Parked
V	Data Set 7026 - Lateral Profile Beneath the Low Concrete Guideway With the Vehicle Levitating
W	Data Set TR7028 - Measurements Near the Inverter Building and Feeder Cables
X	Data Set TR7030 - Measurements Near the Inverter Building and Feeder Cables
Y	Data Set TR7031 - Lateral Profile Above a Feeder Cable (Ground Level)
Z	Data Set TR7032 - Lateral Profile Above a Feeder Cable

LIST OF FIGURES

		<u>PAGE</u>
Figure 2-1	Magnetic field flux densities grouped by frequency partitions within the ELF band and ULF band.....	2-5
Figure 2-2	Typical pseudo-three-dimensional plot of magnetic flux density versus time and frequency.....	2-13
Figure 2-3	Enlargement of the low frequency portion of Figure 2-2.....	2-15
Figure 2-4	Cut across the field versus frequency and time plot of Figure 2-3 to emphasize the frequency spectrum of the magnetic field at the 5 minute point of the data.....	2-16
Figure 2-5	Cut across the field versus frequency and time plot of Figure 2-3 to emphasize the temporal variation of the 75 Hz component of the magnetic field.....	2-17
Figure 2-6	Typical magnetic flux density versus time and frequency plot showing the dynamics of the field characteristics within the TR07 vehicle in response to different vehicle operating conditions.....	2-18
Figure 2-7	Typical three-dimensional plot of magnetic flux density in the low frequency band within the TR07 vehicle as a function of height above the floor and time.....	2-21
Figure 2-8	Typical three-dimensional plot of static magnetic flux density within the TR07 vehicle as a function of height above the floor and time.....	2-23
Figure 3-1	Magnetic flux density versus frequency and time at 13 cm above the floor at the side of the aisle in the center of Car 2.....	3-4
Figure 3-2	Magnetic flux density versus frequency and time at 47 cm above the floor at the side of the aisle in the center of Car 2.....	3-5
Figure 3-3	Magnetic flux density versus frequency and time at 112 cm above the floor at the side of the aisle in the center of Car 2.....	3-6

LIST OF FIGURES (CONT'D)

		<u>PAGE</u>
Figure 3-4	Magnetic flux density versus frequency and time at 175 cm above the floor at the side of the aisle in the center of Car 2.....	3-7
Figure 3-5	Magnetic flux density in the low (5-45 Hz) frequency band versus height above floor and time at the side of the aisle in the center of Car 2.....	3-9
Figure 3-6	Magnetic flux density versus frequency and time at the reference probe location at the rear of the passenger section of Car 2.....	3-10
Figure 3-7	Magnetic flux density versus frequency and time at 175 cm above the floor at the reference probe location at the rear of the passenger section of Car 2.....	3-12
Figure 3-8	Magnetic flux density versus frequency and time measured with the fluxgate sensor 13 cm above the floor at the side of the aisle in the center of Car 2.....	3-13
Figure 3-9	Static magnetic flux density versus height above the floor and time at the side of the aisle in the center of Car 2.....	3-15
Figure 3-10	Minimum, average, and maximum values of static magnetic fields measured in the passenger compartments of the TR07 vehicle for various heights above the floor.....	3-18
Figure 3-11	Minimum, average, and maximum time varying magnetic field in the low frequency (5-45 Hz) band measured in the passenger compartments of the TR07 vehicle for various heights above the floor.....	3-19
Figure 3-12	Minimum, average, and maximum time varying magnetic field in the power frequency (50-60 Hz) band measured in the passenger compartments of the TR07 vehicle for various heights above the floor.....	3-20

LIST OF FIGURES (CONT'D)

PAGE

Figure 3-13 Minimum, average, and maximum time varying magnetic field in the power harmonics (65-300 Hz) band measured in the passenger compartments of the TR07 vehicle for various heights above the floor..... 3-21

Figure 3-14 Minimum, average, and maximum time varying magnetic field in the high frequency (305-2560 Hz) band measured in the passenger compartments of the TR07 vehicle for various heights above the floor..... 3-22

Figure 3-15 Minimum, average, and maximum time varying magnetic field in the frequency range from 5 to 2560 Hz measured in the passenger compartments of the TR07 vehicle for various heights above the floor..... 3-23

Figure 3-16 Field versus time and height above the floor for low frequency (5-45 Hz) magnetic fields in the rear engineer's compartment.....3-27

Figure 3-17 Minimum, average, and maximum values of static magnetic field measured in the engineer's compartment of the TR07 vehicle for various heights above the floor.....3-30

Figure 3-18 Minimum, average, and maximum time varying magnetic field in the low frequency (5-45 Hz) band measured in the engineer's compartment of the TR07 vehicle for various heights above the floor..... 3-31

Figure 3-19 Minimum, average, and maximum time varying magnetic field in the power frequency (50-60 Hz) band measured in the engineer's compartment of the TR07 vehicle for various heights above the floor..... 3-32

LIST OF FIGURES (CONT'D)

	<u>PAGE</u>
Figure 3-20	Minimum, average, and maximum time varying magnetic field in the power harmonics (65-300 Hz) band measured in the engineer's compartment of the TR07 vehicle for various heights above the floor..... 3-33
Figure 3-21	Minimum, average, and maximum time varying magnetic field in the high frequency (305-2560 Hz) band measured in the engineer's compartment of the TR07 vehicle for various heights above the floor..... 3-34
Figure 3-22	Minimum, average, and maximum time varying magnetic field in the frequency range from 5 to 2560 Hz measured in the engineer's compartment of the TR07 vehicle for various heights above the floor..... 3-35
Figure 3-23	Field versus time and distance from center of aisle for AC field lateral profile measurements 5 cm above the floor at the center of the second car..... 3-36
Figure 3-24	Field versus time and distance from the center of the aisle for static field lateral profile measurements 5 cm above the floor at the center of the second car..... 3-37
Figure 3-25	Time varying magnetic field as a function of time and frequency 5 cm above the floor at the edge of the aisle in the middle of Car 2..... 3-39
Figure 3-26	Static and low frequency magnetic field as a function of time and frequency 5 cm above the floor at the edge of the aisle in Car 2..... 3-40

LIST OF FIGURES (CONT'D)

PAGE

Figure 3-27	Magnetic flux density for a measuring point on the floor of the TR06 vehicle as a function of the frequency and its magnitude in the seating area of the passenger accommodation. - The Earth's magnetic field in comparison: about 5×10^{-5} Tesla.....	3-42
Figure 3-28	Magnetic field on the TR07 vehicle measured with an EMDEX meter worn at waist level and approximate vehicle speed during the measurements.....	3-44
Figure 4-1	Typical field versus time and frequency plot for measurements beneath the guideway.....	4-5
Figure 4-2	Typical field versus time and frequency plot for measurements 3 m from centerline of the guideway.....	4-6
Figure 4-3	Typical field versus time and frequency plot for measurements 10 m from centerline of the guideway.....	4-7
Figure 4-4	Typical field versus time and distance from the guideway plot for the low frequency (5-45 Hz) band showing field attenuation away from the guideway and lack of significant field when the guideway is not energized.....	4-8
Figure 4-5	Typical field versus time and frequency plot three meters from centerline of the guideway at a point 25 meters north of the point for which the data in Figure 4-2 was recorded.....	4-9
Figure 4-6	Typical field versus time and frequency plot three meters from centerline of the guideway at a point 25 meters south of the point for which the data in Figure 4-2 was recorded.....	4-10

LIST OF FIGURES (CONT'D)

		<u>PAGE</u>
Figure 4-7	Typical field versus time and frequency plot for static and low frequency measurements beneath or near the guideway.....	4-12
Figure 4-8	Typical plot of static field versus time and distance from the high steel guideway showing no effect of passing vehicles on static field but a passive field enhancement by the guideway structure.....	4-13
Figure 4-9	Lateral profile of mean static field level one meter above ground as a function of distance from centerline of the guideway.....	4-18
Figure 4-10	Lateral profile of maximum time varying magnetic field in the 5 to 45 Hz frequency band one meter above ground as a function of distance from centerline of the guideway.....	4-19
Figure 4-11	Lateral profile of maximum time varying magnetic field in the 50 to 60 Hz frequency band one meter above ground as a function of distance from centerline of the guideway.....	4-20
Figure 4-12	Lateral profile of maximum time varying magnetic field in the 65 to 300 Hz frequency band one meter above ground as a function of distance from centerline of the guideway.....	4-21
Figure 4-13	Lateral profile of maximum time varying magnetic field in the 305 to 2560 Hz frequency band one meter above ground as a function of distance from centerline of the guideway.....	4-22
Figure 4-14	Lateral profile of maximum time varying magnetic field in the 5 to 2560 Hz frequency band one meter above ground as a function of distance from centerline of the guideway.....	4-23

LIST OF FIGURES (CONT'D)

PAGE

Figure 4-15	Magnetic flux density versus frequency and time measured with a fluxgate sensor beneath the low concrete guideway 6 meters from the lateral profile with the TR07 vehicle levitating overhead.....	4-26
Figure 4-16	Magnetic flux density versus frequency and time measured with a fluxgate sensor beneath the low concrete guideway at the lateral profile point with the TR07 vehicle levitating overhead.....	4-27
Figure 5-1	Magnetic flux density versus frequency and time measured with a fluxgate sensor located 5 cm above the deck of the loading platform 2.5 m from centerline of the guideway.....	5-4
Figure 6-1	Location of power supply equipment and related magnetic field measurements.....	6-2
Figure 6-2	Flux density versus frequency and time for measurements with a coil-type field probe at the center of the south edge of the transformer yard.....	6-7
Figure 6-3	Flux density by frequency and time plot for the same conditions in Figure 6-2 but at higher frequencies.....	6-8
Figure 6-4	Field versus time and distance from the transformer yard for time varying AC field measurements in the 65 to 300 Hz range.....	6-9
Figure 6-5	Flux density versus frequency and time for measurements with a coil-type sensor at the center of the north edge of the braking resistor yard.....	6-12
Figure 6-6	Flux density versus frequency and time for the same conditions in Figure 6-5 but at higher frequencies.....	6-13
Figure 6-7	Field versus time and distance from the resistor yard for time varying magnetic fields in the 65 to 300 Hz range.....	6-15

LIST OF FIGURES (CONT'D)

		<u>PAGE</u>
Figure 6-8	Field versus time and distance from the inverter building for time varying magnetic fields in the frequency range from 5 to 2560 Hz during the first measurements.....	6-18
Figure 6-9	Field versus time and distance from the inverter building for time varying magnetic fields in the frequency range from 5 to 2560 Hz during the second measurements.....	6-19
Figure 6-10	Total time varying magnetic flux density versus presumed horizontal distance from the buried feeder cable during the first test near the inverter building.....	6-21
Figure 6-11	Total time varying magnetic flux density versus presumed horizontal distance from the buried feeder cable during the second test near the inverter building.....	6-22
Figure 6-12	Total time varying magnetic flux density versus presumed horizontal distance from the guideway centerline during the first test beneath the high steel guideway (the presumed cable location is 3.5 m east of the guideway).....	6-23
Figure 6-13	Total time varying magnetic flux density versus presumed horizontal distance from the guideway centerline during the second test beneath the high steel guideway (the presumed cable location is 3.5 m east of the guideway).....	6-24
Figure 7-1	Illustration of how the magnetic field intensity at ground level changes with horizontal distance from three common sources of power-frequency magnetic fields. The bands represent variation across individual sources in each group. Adapted from Nair et al ⁶	7-4

LIST OF FIGURES (CONT'D)

	<u>PAGE</u>
Figure 7-2	Magnetic field 30 cm from a shop vac..... 7-6
Figure 7-3	Comparison of the range of time varying magnetic field within the passenger compartment of the TR07 vehicle as a function of height above the floor to power frequency magnetic fields from other sources..... 7-10
Figure 7-4	Comparison of the range of time varying magnetic field within the engineer's compartment of the TR07 vehicle as a function of height above the floor to power frequency magnetic fields from other sources..... 7-11
Figure 7-5	Comparison of the range of time varying magnetic field near the guideway of the TR07 vehicle to power frequency magnetic fields from other sources..... 7-12
Figure 7-6	Comparison of the range of time varying magnetic field at the TR07 station platform level to power frequency magnetic fields from other sources..... 7-14
Figure 7-7	Comparison of the range and mean level of time varying magnetic field at increasing distances from the edge of the transformer yard to power frequency magnetic fields from other sources..... 7-15
Figure 7-8	Comparison of the range and mean level of time varying magnetic field at increasing distances from the edge of the braking resistor yard to power frequency magnetic fields from other sources..... 7-17
Figure 7-9	Comparison of the range and mean level of time varying magnetic field at increasing distances from the inverter building to power frequency magnetic fields from other sources..... 7-18

LIST OF FIGURES (CONT'D)

PAGE

Figure 7-10	Comparison of the range and mean level of time varying magnetic field at increasing distances from the centerline of the underground feeder cables to power frequency magnetic fields from other sources.....	7-19
-------------	---	------

LIST OF TABLES

	<u>PAGE</u>
Table 2-1 Index of Repetitive Waveform Data TR07 Measurements, August 1990	2-8
Table 3-1 Summary of Repetitive Waveform Measurements Onboard the Transrapid TR07 Vehicle	3-2
Table 3-2 Summary Data for Magnetic Field Measurements Within the Passenger Compartments of the TR07 Vehicle	3-16
Table 3-3 Summary Data for the Stationary Reference Probes at the Rear Bulkhead of the Main Passenger Compartment of the TR07 Vehicle	3-24
Table 3-4 Summary Data for Magnetic Field Measurements Within the Passenger Compartments of the TR07 by Location	3-26
Table 3-5 Summary Data for the Magnetic Field Measurements Within the Rear Engineer's Compartment of the TR07 Vehicle	3-29
Table 4-1 Summary of Repetitive Waveform Measurements Near the Transrapid TR07 Guideway	4-2
Table 4-2 Summary Data for Magnetic Field Measurements Beneath the High Steel Guideway Near the Control Building	4-14
Table 4-3 Summary Data for Magnetic Field Measurements Beneath the Low Concrete Guideway in the South Loop	4-15
Table 4-4 Summary Data for Magnetic Field Measurements Beneath the High Concrete Guideway at the Loading Platform	4-16
Table 4-5 Summary Data for Magnetic Field Measurements Beneath the Low Concrete Guideway with the Stationary TR07 Vehicle Levitating Overhead	4-25
Table 5-1 Summary Data for Magnetic Field Measurements at the Passenger Station	5-2
Table 6-1 Summary of Repetitive Waveform Measurements Near Various Components of the TR07 Power Supply Equipment	6-4

LIST OF TABLES (CONT'D)

PAGE

Table 6-2	Summary Data for the Magnetic Field Measurements at the South Edge of the Output Transformer Yard	6-6
Table 6-3	Summary Data for the Magnetic Field Measurements at the North Edge of the Braking Resistor Yard	6-11
Table 6-4	Summary Data for the Magnetic Field Measurements at the Northeast Corner of the Inverter Building	6-16
Table 6-5	Summary Data for Magnetic Field Measurements Above the Main Feeder Cables at a Point 15 M Northeast of the Inverter Building	6-25
Table 6-6	Summary Data for Magnetic Field Measurements Above the South Loop Feeder Cable Approximately 3.5 M East of the High Steel Guideway	6-27
Table 7-1	Summary Data for Magnetic Field Measurements Within the Passenger Compartments of the TR07 Vehicle	7-22
Table 7-2	Summary Data for the Magnetic Field Measurements Within the Rear Engineer's Compartment of the TR07 Vehicle	7-23
Table 7-3	Summary Data for Magnetic Field Measurements Beneath the Low Concrete Guideway in the South Loop	7-24
Table 7-4	Summary Data for Magnetic Field Measurements at the Passenger Station	7-25
Table 7-5	Summary Data for the Magnetic Field Measurements at the South Edge of the Output Transformer Yard	7-26
Table 7-6	Summary Data for Magnetic Field Measurements Above the Main Feeder Cables at a Point 15 M Northeast of the Inverter Building	7-27

APPENDIX A
GUIDE TO APPENDED DATA

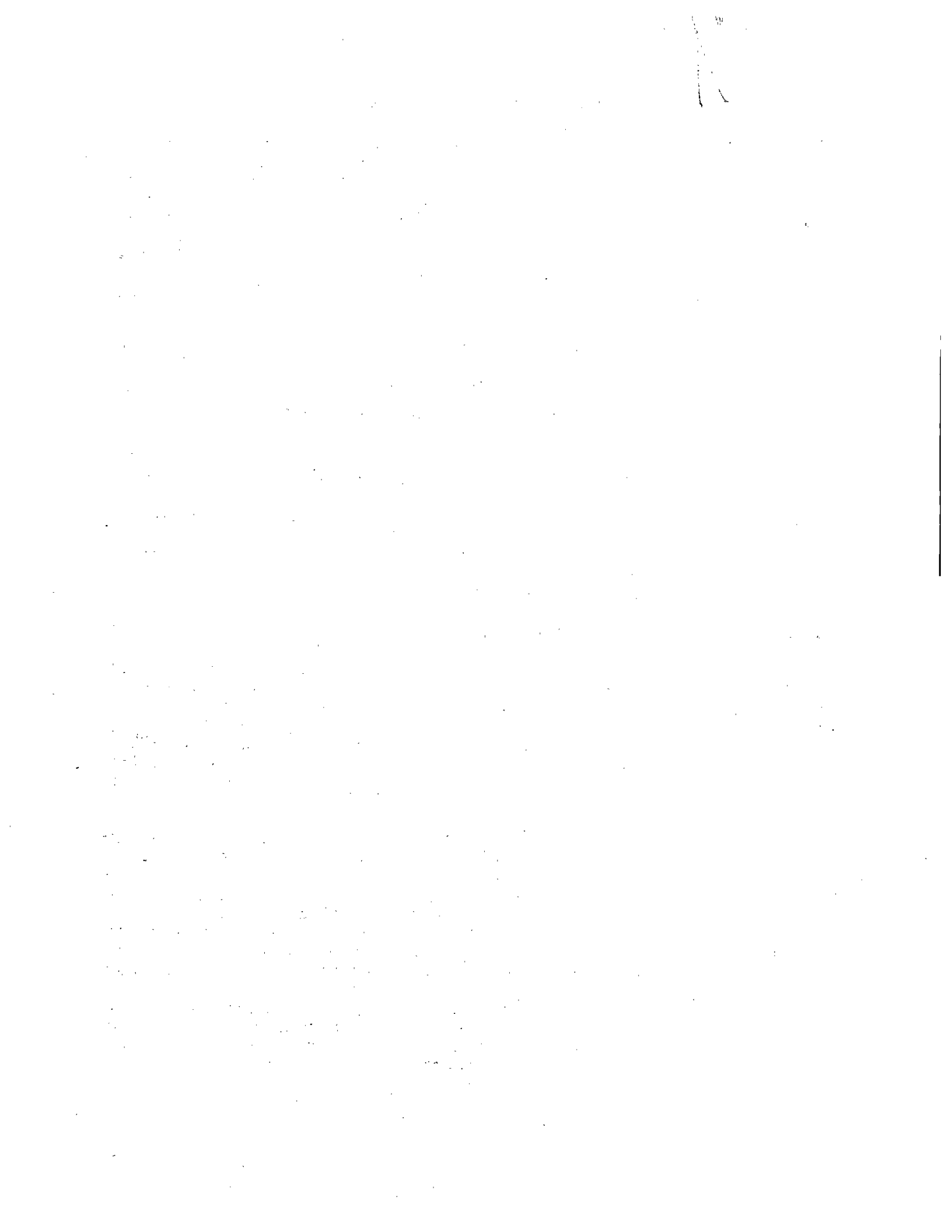

DESCRIPTION OF APPENDED DATA

The following 25 appendices contain a detailed reporting of the magnetic field characteristics measured onboard the TR07 vehicle and near associated facilities. The data have been consolidated and presented as efficiently as possible without resorting to summary measures which obscure the temporal or frequency characteristics of the magnetic fields. The analysis of summary data obtained by collapsing the frequency spectra into a small number of relatively broad bands or by collapsing the time distributions into statistical parameters is found in the body of the report.

One appendix is provided for each of the 25 repetitive waveform data sets collected during the August 1990 measurement program. Most appendices contain the following material:

- Table of measurement parameters
- Sketch of sensor locations
- Vehicle speed profile
- Field by frequency and time plots for each coil-type AC field sensor
- Field by frequency and time plots for each fluxgate-type static field sensor
- Field by distance and time plot for six frequency bands

Each of these items is described below.

Table of Measurement Parameters

Each appendix begins with a table of measurement parameters. It identifies the data set by number and title and gives measurement setup code which refers to the detailed description of probe locations provided in the Interim Report. (A copy of the setup sketch from the Interim Report is also included in each appendix directly behind the table of parameters.) The vehicle status entry indicates whether the TR07 vehicle was operating during the test and includes general comments on the mode of operation.

The next group of data on the table of measurement parameters identifies the time during which repetitive waveform measurements were made. Start and stop time are merely clock times for the first and last waveform samples, respectively. During that time period, the indicated number of waveform samples were taken. The programmed sample interval and actual sample interval represent the requested and actual time between successive waveform samples. These should agree, except during those tests in which the test engineers wanted the MultiWave™ System to sample as frequently as possible. To accomplish that end, they programmed a sample interval slightly shorter than the system was actually capable of achieving. The distinction between the programmed sample interval and actual sample interval is important to the reader because the

time axis on all of the reported data is derived from the number of samples and the programmed sample interval. Hence, the time interval identified on the graph will be slightly less than the actual clock time in those cases where the MultiWave™ System was forced to run at its maximum rate by programming a sample interval shorter than the device was capable of providing. If the reader wishes to correct the time scales on plotted data to actual clock time, he must multiply the reported times by the ratio of the actual sample period to the programmed sample period.

The table of measurement parameters also contains various parameters from the waveform sampling and subsequent Fourier transformation of the waveform data that affect the interpretation of the magnetic field frequency spectra. The tabulated maximum frequency and minimum frequency are center frequencies of the upper and lower components of the Fourier transform. The spectral bandwidth is the interval between frequency components in the Fourier transform and is effectively the smallest increment in frequency that can be resolved in the frequency spectrum. The spectral bandwidth parameter is also important to the reader because the intensity of broadband magnetic field components (as opposed to fields at unique discrete frequencies) such as the lower frequency components of the magnetic fields near the TR07 vehicle is proportional to the square root of the bandwidth. Consequently, to compare the spectral data for broadband signals contained in these appendices to values reported by others, one must make the appropriate bandwidth adjustments to the data.

The final item on the table of measurement parameters is a listing of any missing or suspect data within that particular data set.

Sensor Location Sketch

Each appendix contains a copy of the sensor location sketch from the Interim Report which applies to that particular data set. Some of these sketches report more than one set-up configuration. The one applicable to the data set of the appendix is identified on the table of measurement parameters as "Measurement Setup Code."

Vehicle Speed Profile

During the magnetic field measurements onboard the TR07 vehicle, the test engineers maintained a manual log of vehicle speed readings from the vehicle's speedometer. Those data are plotted in the vehicle speed profile and are useful when interpreting the changes in magnetic field conditions which occur over the time of the measurements.

Field by Frequency and Time Plots for Coil-Type AC Field Sensors

The first set of data plots in each appendix are the field by frequency and time plots for each coil-type AC field sensor. These

plots are described in more detail in Section 2 of this report. Although all of the measurements with coil-type sensors extended out to a maximum frequency of 2560 Hz, only that portion of the spectrum containing fields of significant amplitude were plotted. In some cases, supplemental plots showing extended portions of the frequency spectrum or "blow-ups" of portions of the time domain are included to show interesting field characteristics in more detail.

Field by Frequency and Time Plots for Fluxgate-Type Field Sensors

The second set of data plots in each appendix are the field by frequency and time plots for magnetic fields measured with the fluxgate sensors. These are similar in construction to the plots for measurements with the coil-type sensors, except that they focus on the static field and very low frequency components of the time varying fields. They are generally distinguishable by the presence of the large static component at the left edge of the graph. Since the spectral bandwidth used in the magnetic field measurements and analysis with the fluxgate sensors is not the same in all data sets, but is always smaller than that used for the measurements with the coil-type sensors, the reader must determine the spectral bandwidth for these data from the table of measurement parameters and make the necessary bandwidth corrections prior to attempting quantitative comparisons of the intensity of broadband magnetic field components between data sets or between the coil-type and fluxgate-type measurements.

Field by Distance and Time Plots

The last group of graphs in each appendix show the intensity of the field in each of six frequency bands as a function of distance from some reference point (such as floor of the vehicle, centerline of the guideway, etc.) over the time of the measurements. These graphs were created for each set of measurements whether the spatial distribution was expected to help identify the source of the magnetic field or establish an attenuation rate which would be useful for predicting field intensities at other distances from the source.

The spatial sampling of the magnetic field level is by necessity limited to only the few points where magnetic field sensors were placed (see the sketch of sensor locations in each appendix). From this relatively sparse sample, the contours of the field by distance and time plots were generated by a computer program which attempts to fit a surface to the available data points. These plots are therefore very accurate at the sensor locations but represent a "best fit" approximation of the field levels between sensor locations. In those cases where the attenuation data are orderly and consistent, the contours are expected to be a good approximation of reality. However, in the cases where field values are erratic or inconsistent between probe locations, the validity of the contour is more uncertain at places other than the sample

locations. In evaluating these curves, the reader should be cognizant of the actual measurement locations and place the most credibility in the data at those locations.

B-1

APPENDIX B

DATA SET TR7001

**VEHICLE PASSENGER SECTION,
WINDOW SEAT, MID CAR**

APPENDIX B

DATA SET TR7001
VEHICLE PASSENGER SECTION, WINDOW SEAT, MID CAR

Measurement Setup Code: 4 (coil-type) & 3 (fluxgate-type)
Vehicle Status: Running continuously
Measurement Date: August 7, 1990
Measurement Time: Start: 10:20:00
End: 10:30:00
Number of Samples: 21
Programmed Sample Interval: 30 sec
Actual Sample Interval: 30 sec

Frequency Spectrum Parameters

<u>Probe Type:</u>	<u>Coil (AC)</u>	<u>Fluxgate (DC)</u>
Maximum Frequency (Hz)	2560	512
Minimum Frequency (Hz)	5	0
Spectral Bandwidth (Hz)	5	1

Missing or Suspect Data: None

ON-VEHICLE MEASUREMENT POINTS (AUG. 7, '90)

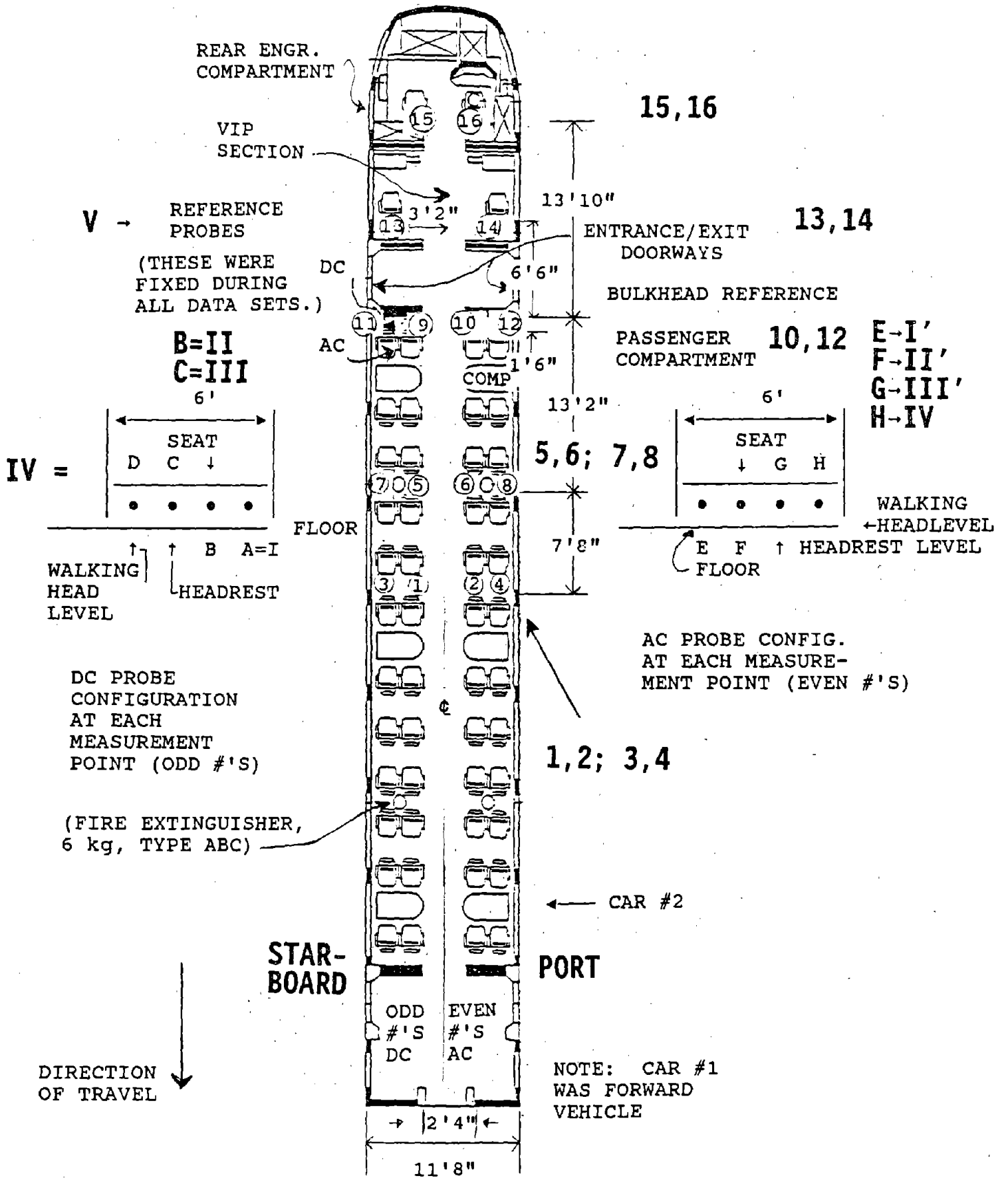

VEHICLE SPEED - TR7001

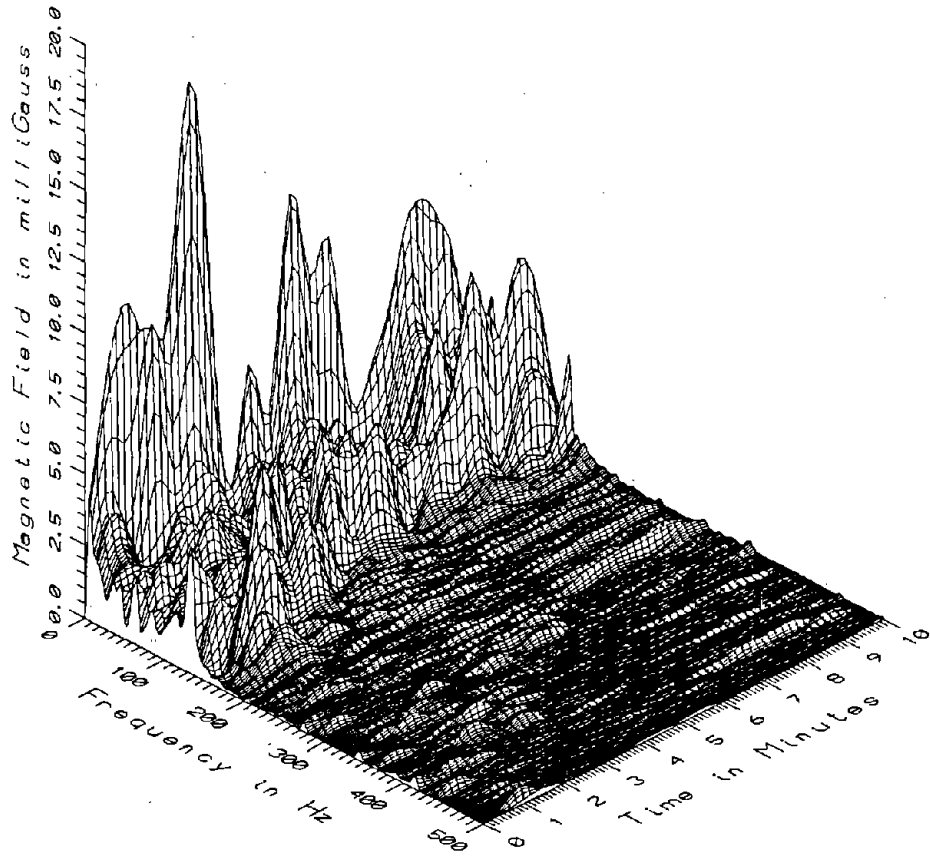
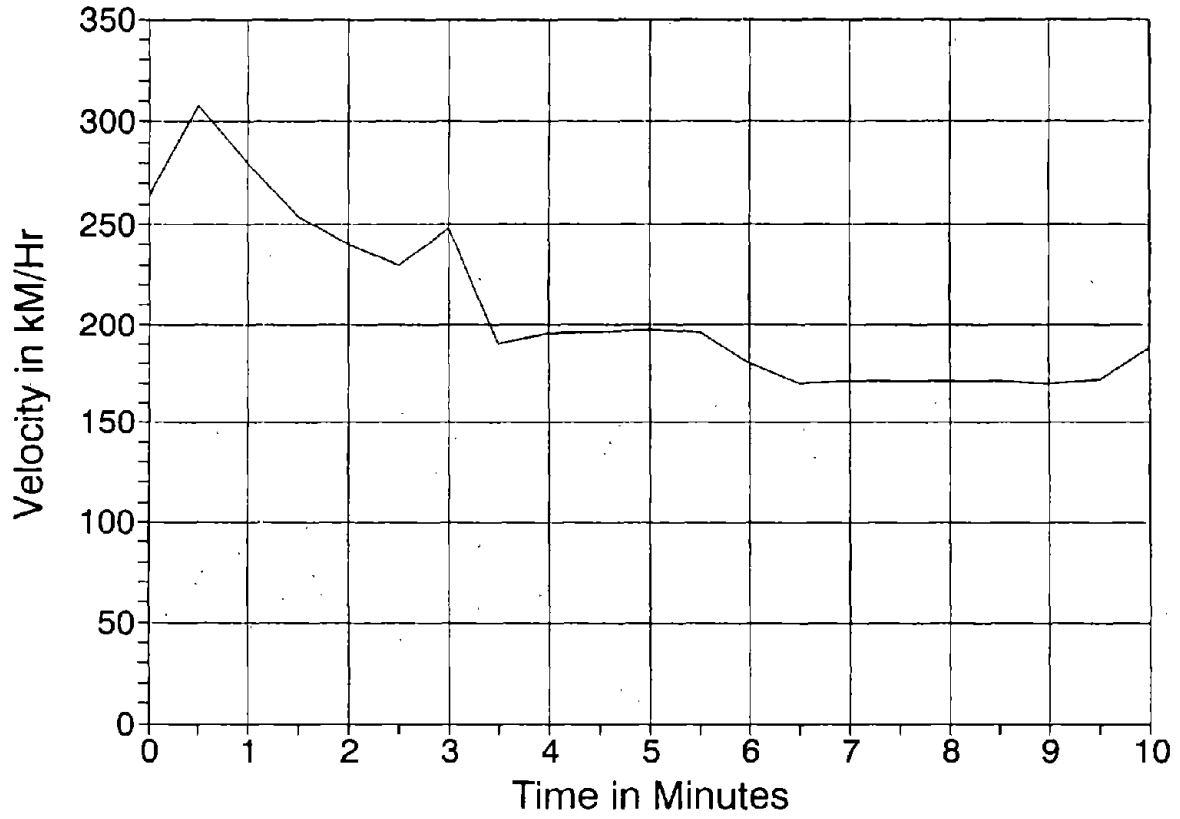

TR7001 - STANDING HEAD LEVEL - WINDOW SEAT IN MIDDLE OF PASSENGER SECTION, CAR#

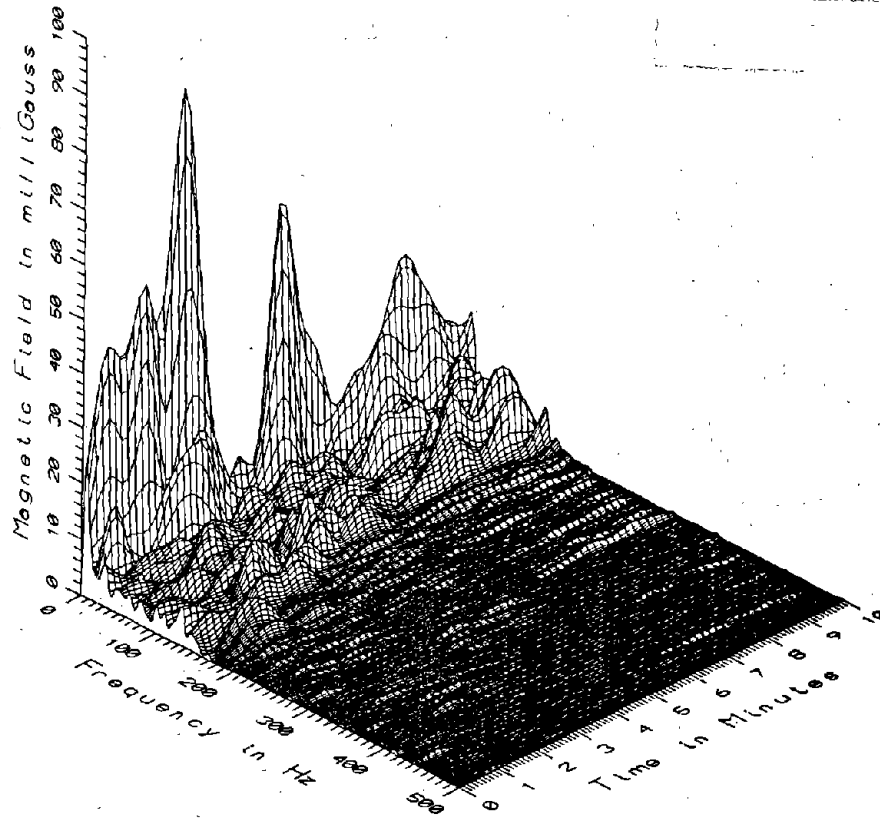

TR7001 - SEAT LEVEL - WINDOW SEAT IN MIDDLE OF PASSENGER SECTION, CAR#2

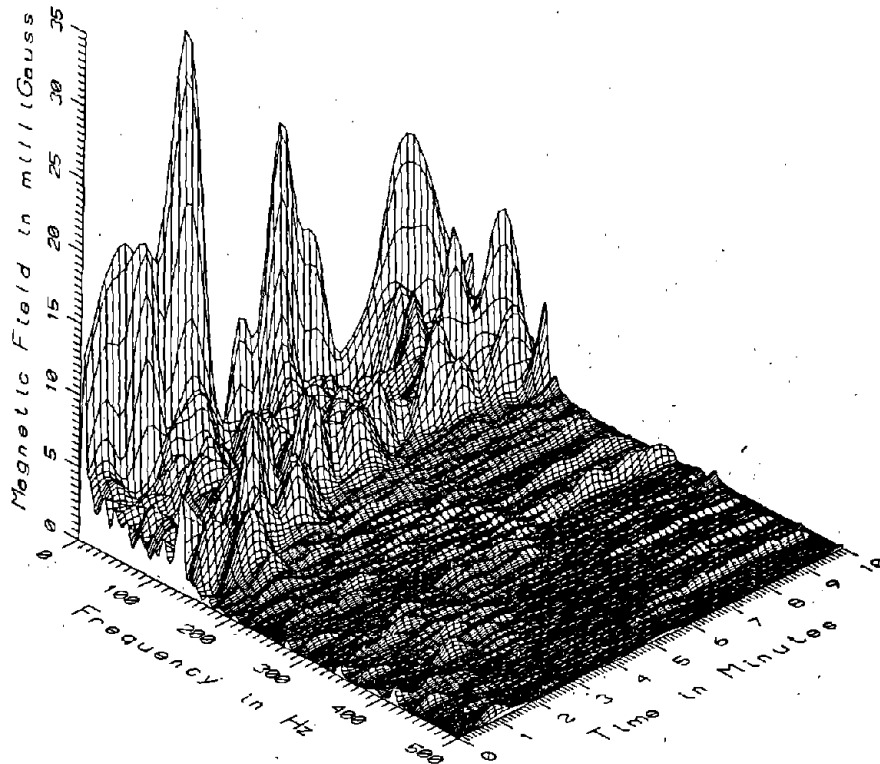

TR7001 - SEATED HEAD LEVEL - WINDOW SEAT IN MIDDLE OF PASSENGER SECTION, CAR#2

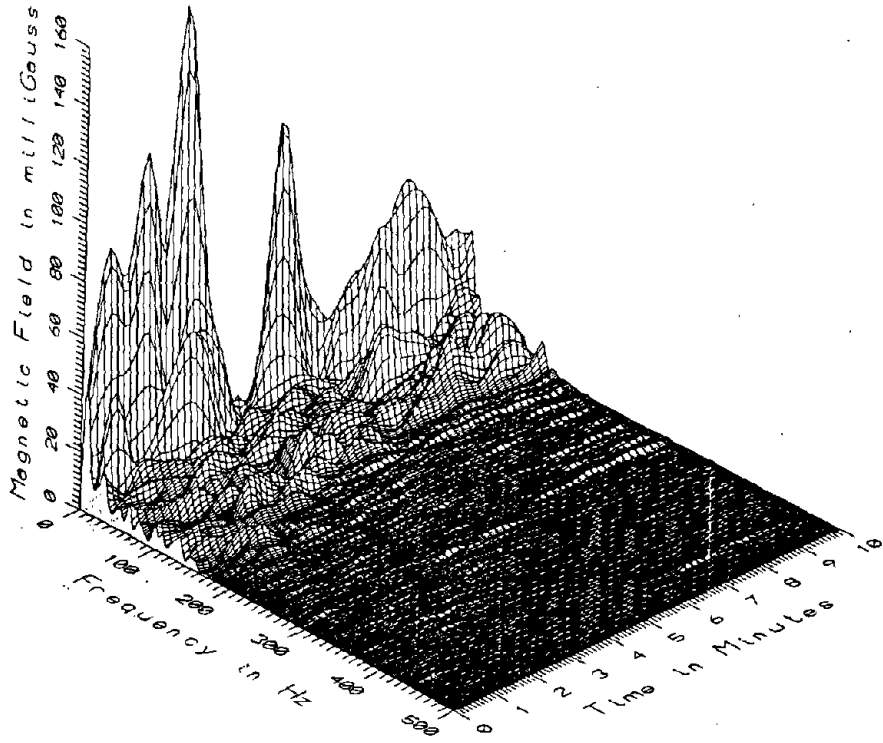

TR7001 - FLOOR LEVEL - WINDOW SEAT IN MIDDLE OF PASSENGER SECTION, CAR#2

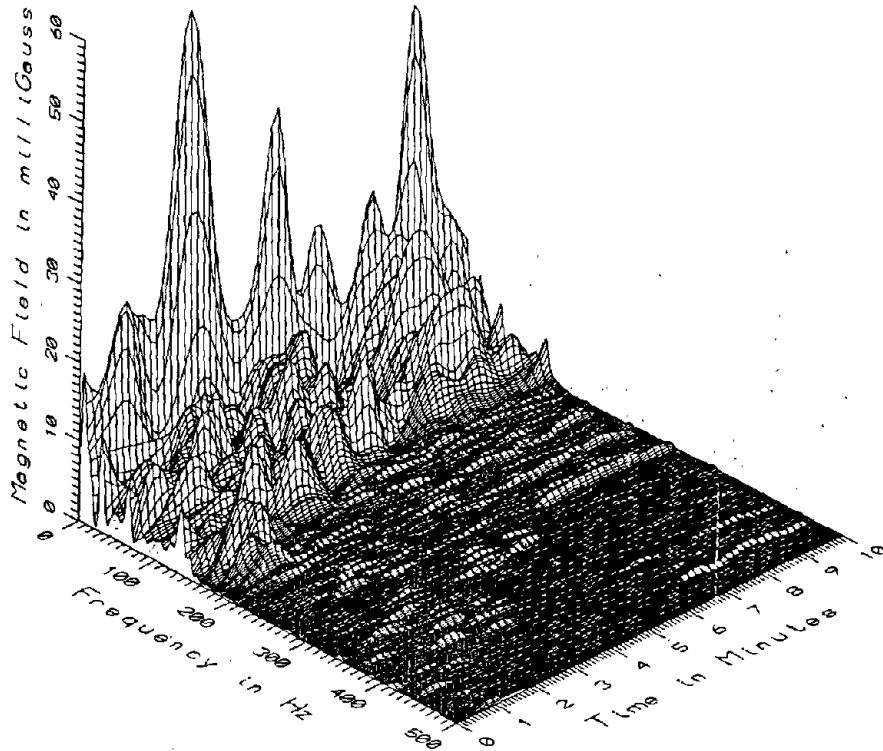

TR7001 - REFERENCE PROBE - BULKHEAD IN REAR OF PASSENGER SECTION, CAR#2

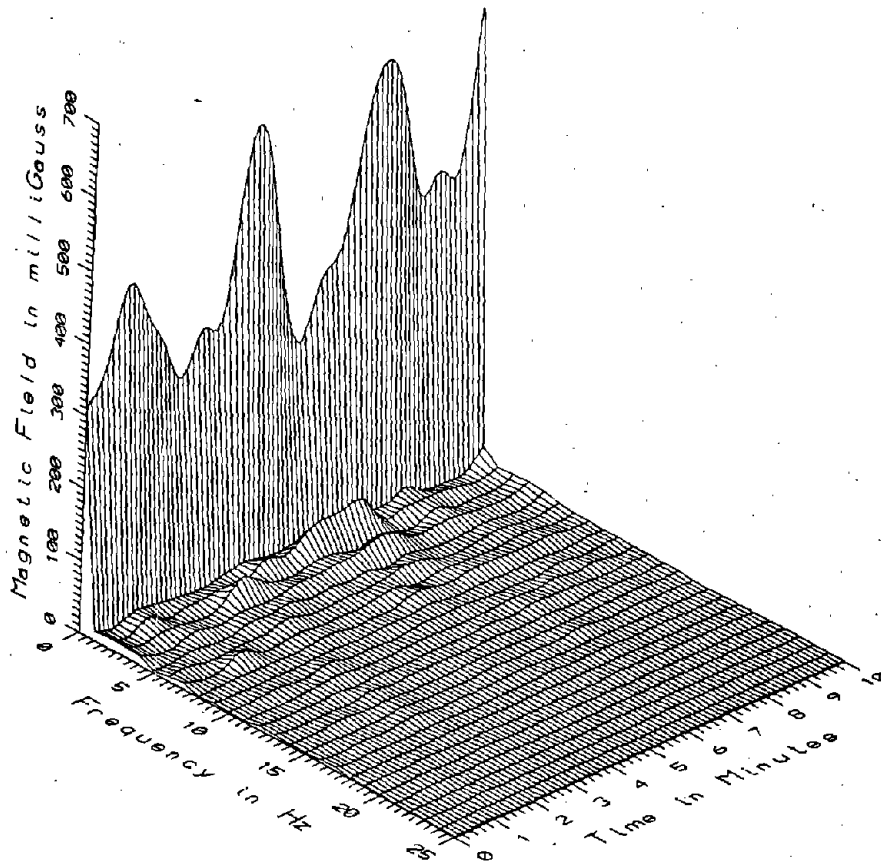

TR7001 - STANDING HEAD LEVEL - WINDOW SEAT IN MIDDLE OF PASSENGER SECTION, CAR#2

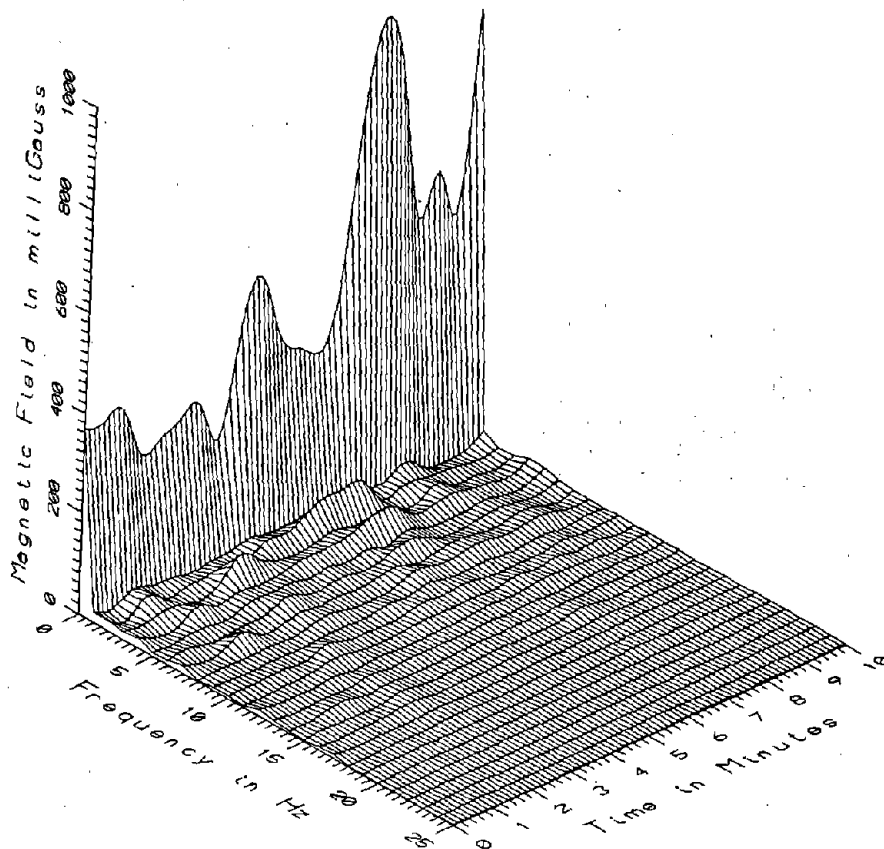

TR7001 SEATED HEAD LEVEL - WINDOW SEAT IN MIDDLE OF PASSENGER SECTION, CAR#2

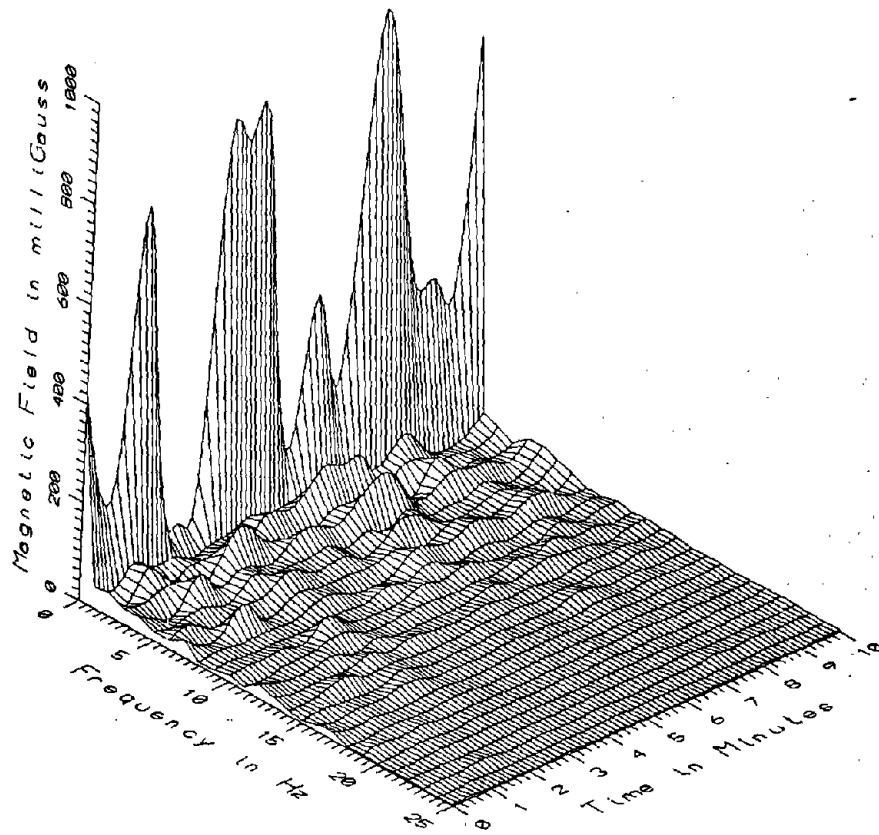

TR7001 - SEAT LEVEL - WINDOW SEAT IN MIDDLE OF PASSENGER SECTION, CAR#2

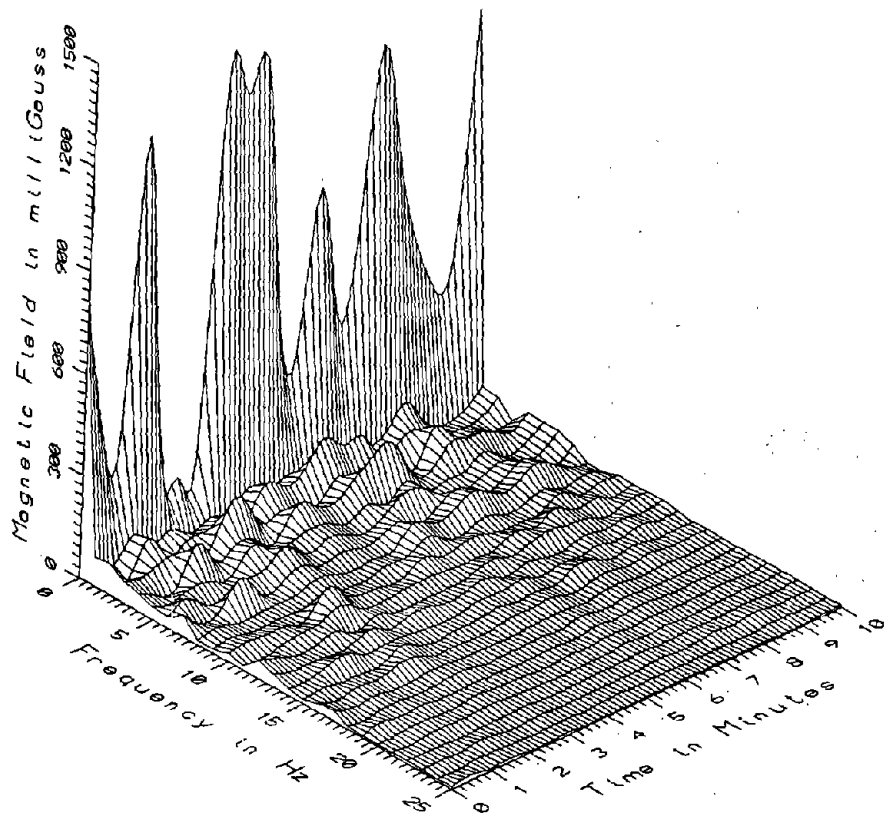

TR7001 - FLOOR LEVEL - WINDOW SEAT IN MIDDLE OF PASSENGER SECTION, CAR#2

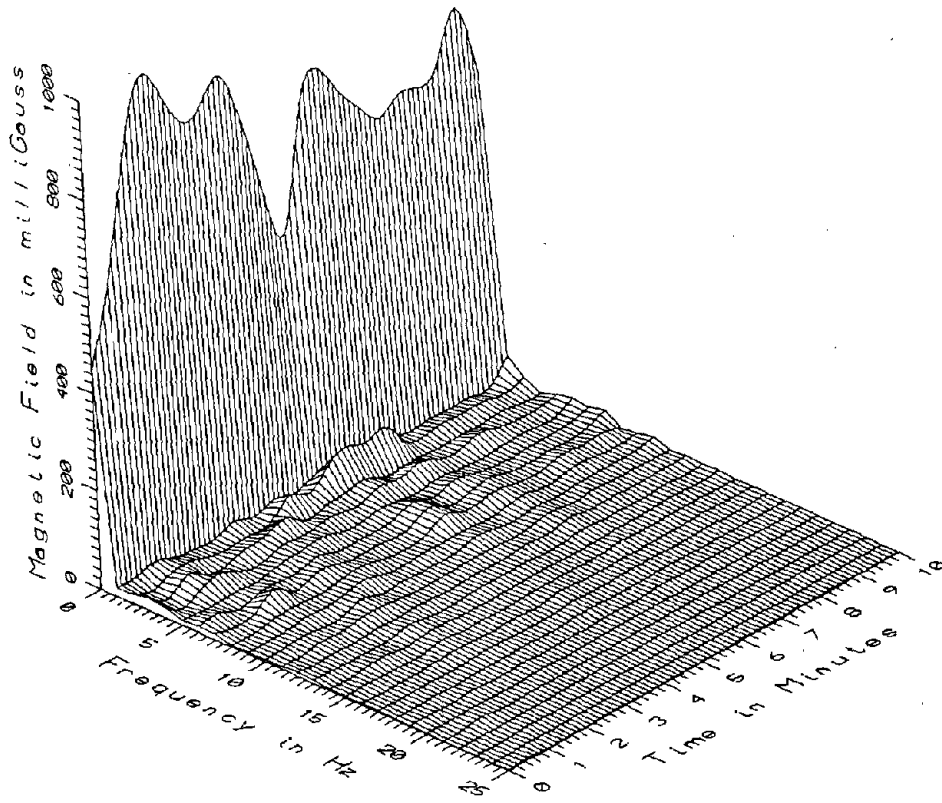

TR7001 - REFERENCE PROBE - BULKHEAD IN REAR OF PASSENGER SECTION, CAR#2

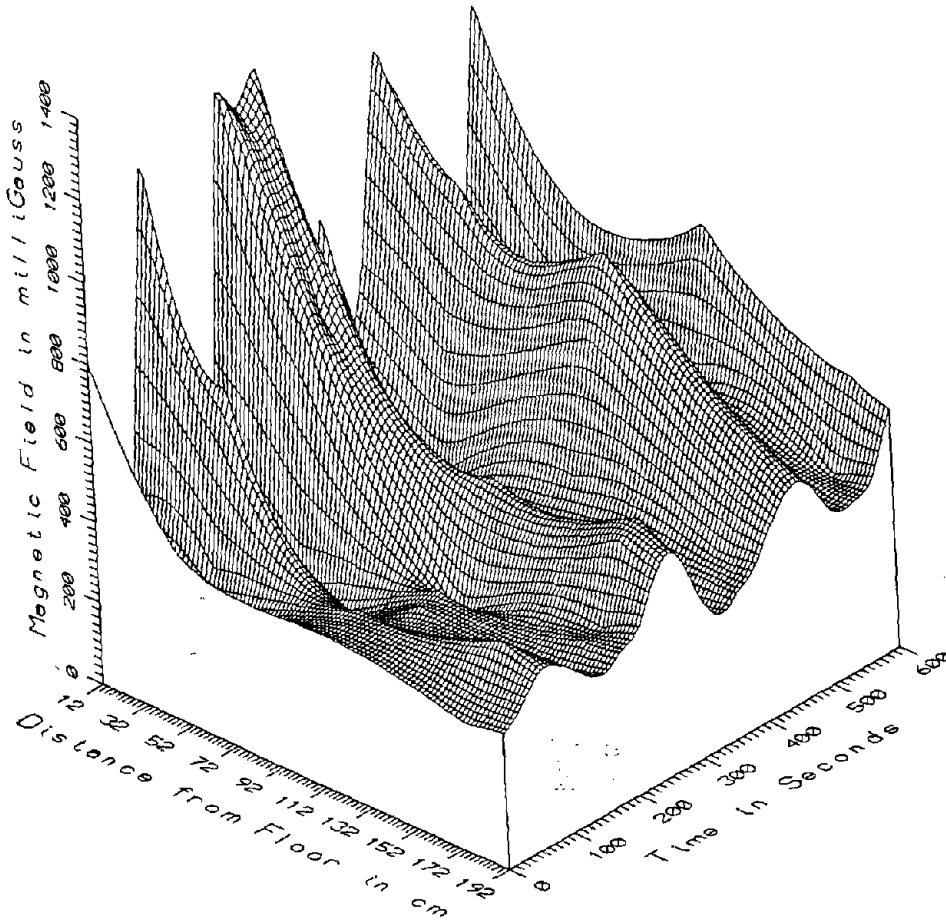

TR7001 - WINDOW SEAT IN MIDDLE OF PASSENGER SECTION, CAR2 - DC

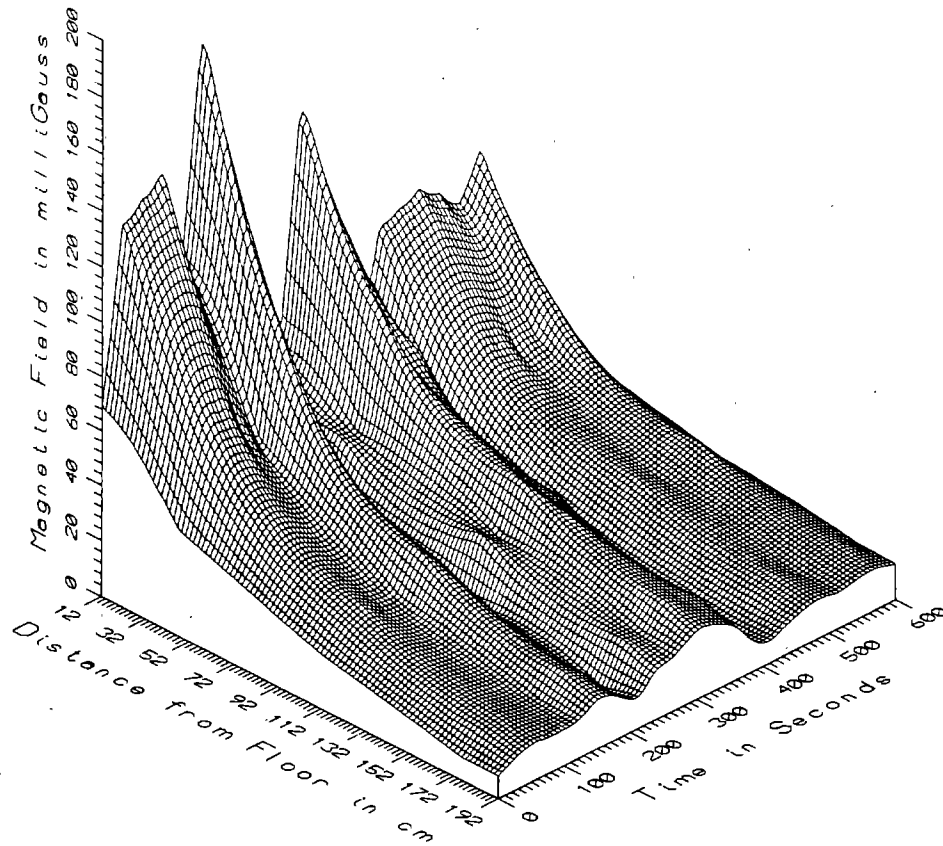

TR7001, WINDOW SEAT IN MIDDLE OF PASSENGER SECTION, CAR2 - LOW FREQUENCY, 5-45Hz

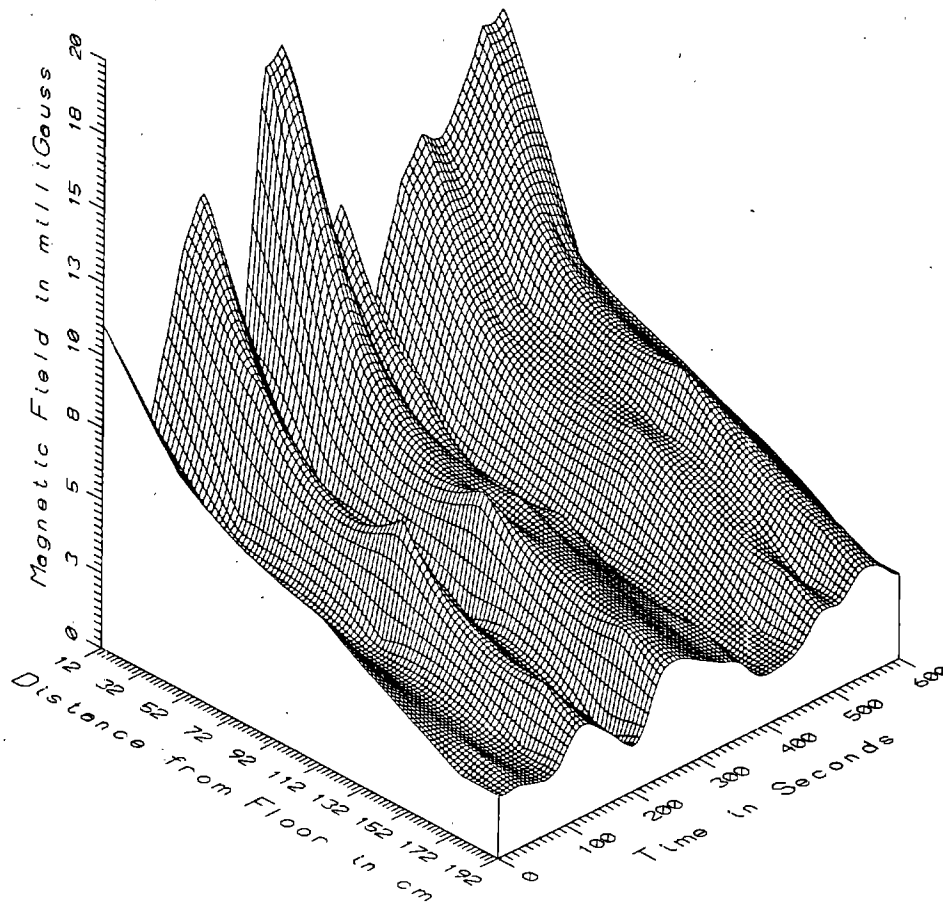

TR7001, WINDOW SEAT IN MIDDLE OF PASSENGER SECTION, CAR2 - POWER FREQ. 50-60Hz

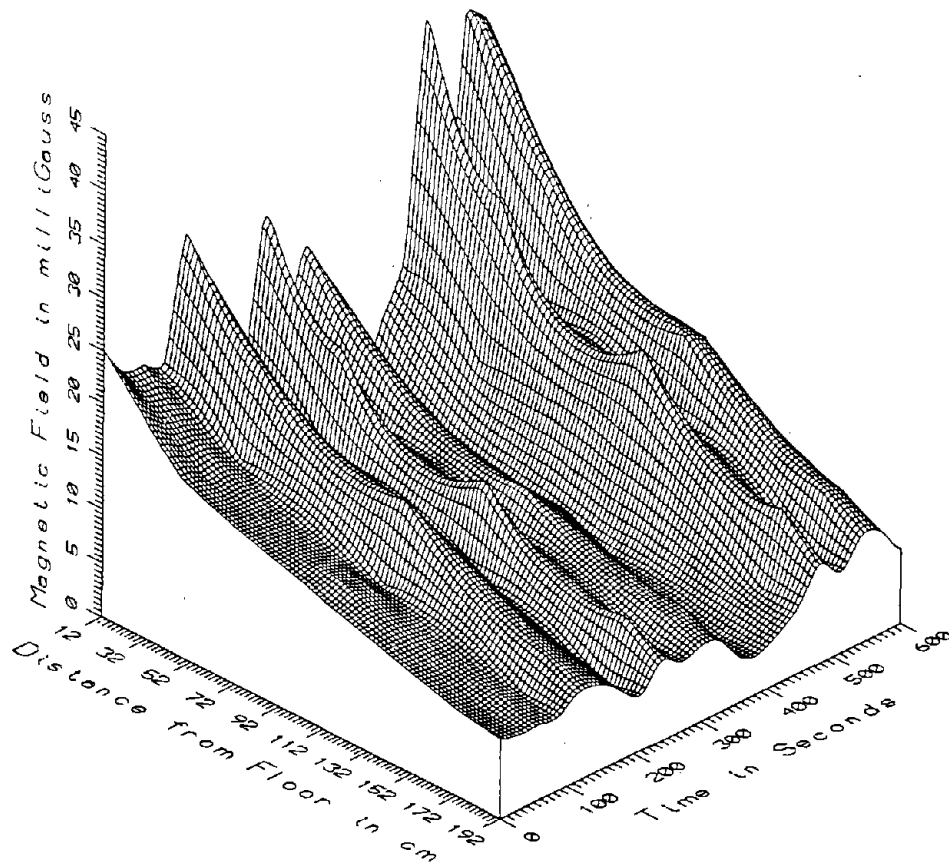

TR7001, WINDOW SEAT IN MIDDLE OF PASSENGER SECTION, CAR2 - POWER HARM 65-300Hz

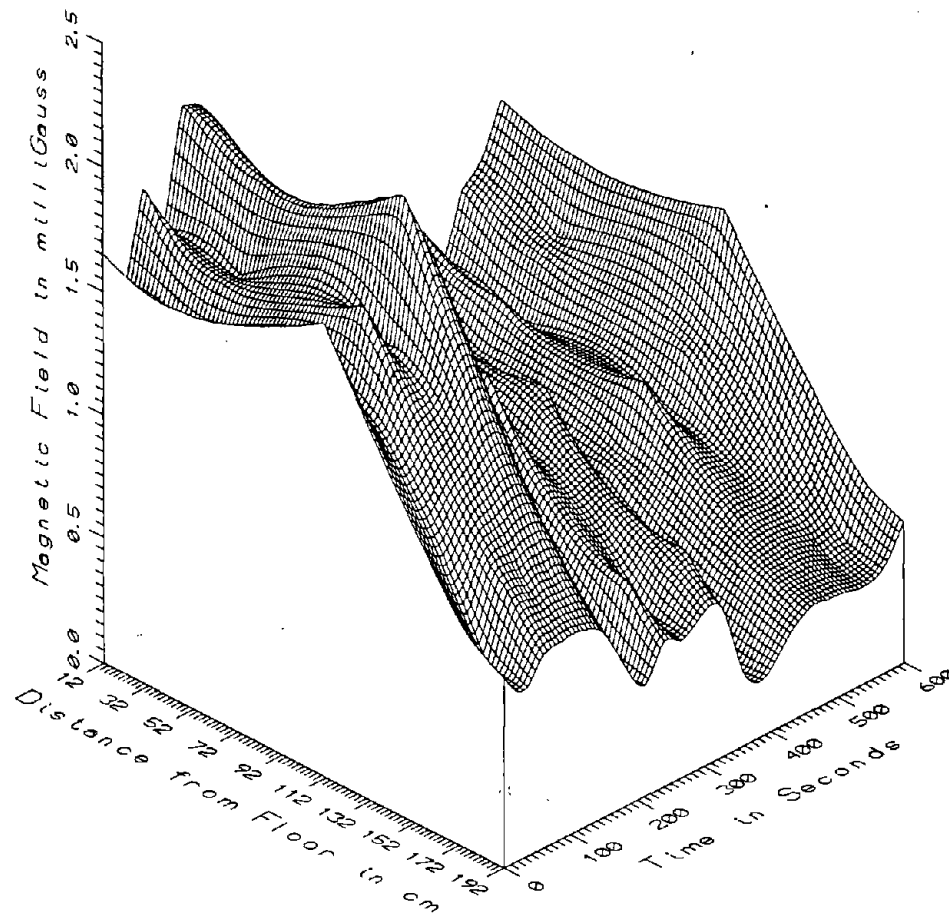

TR7001, WINDOW SEAT IN MIDDLE OF PASSENGER SECTION, CAR2 - HIGH FREQ 305-2560Hz

B-11

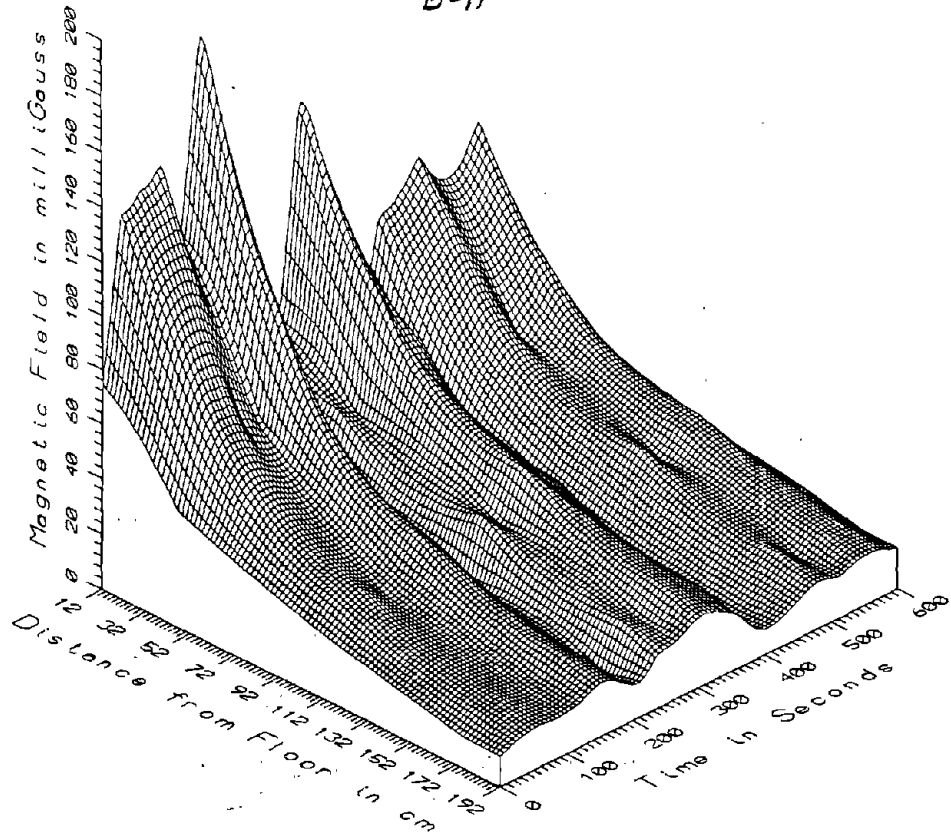

TR7001, WINDOW SEAT IN MIDDLE OF PASSENGER SECTION, CAR2 - ALL FREQ 5-2560Hz

C-1

APPENDIX C

DATA SET TR7002

**VEHICLE PASSENGER SECTION,
AISLE SEAT, MID CAR**

APPENDIX C

DATA SET TR7002
VEHICLE PASSENGER SECTION, AISLE SEAT, MID CAR

Measurement Setup Code: 2 (coil-type) & 1 (fluxgate-type)
Vehicle Status: Running continuously
Measurement Date: August 7, 1990
Measurement Time: Start: 10:38:00
End: 10:48:00
Number of Samples: 21
Programmed Sample Interval: 30 sec
Actual Sample Interval: 30 sec

Frequency Spectrum Parameters

<u>Probe Type:</u>	<u>Coil (AC)</u>	<u>Fluxgate (DC)</u>
Maximum Frequency (Hz)	2560	512
Minimum Frequency (Hz)	5	0
Spectral Bandwidth (Hz)	5	1

Missing or Suspect Data: None

C-1

ON-VEHICLE MEASUREMENT POINTS (AUG. 7, '90)

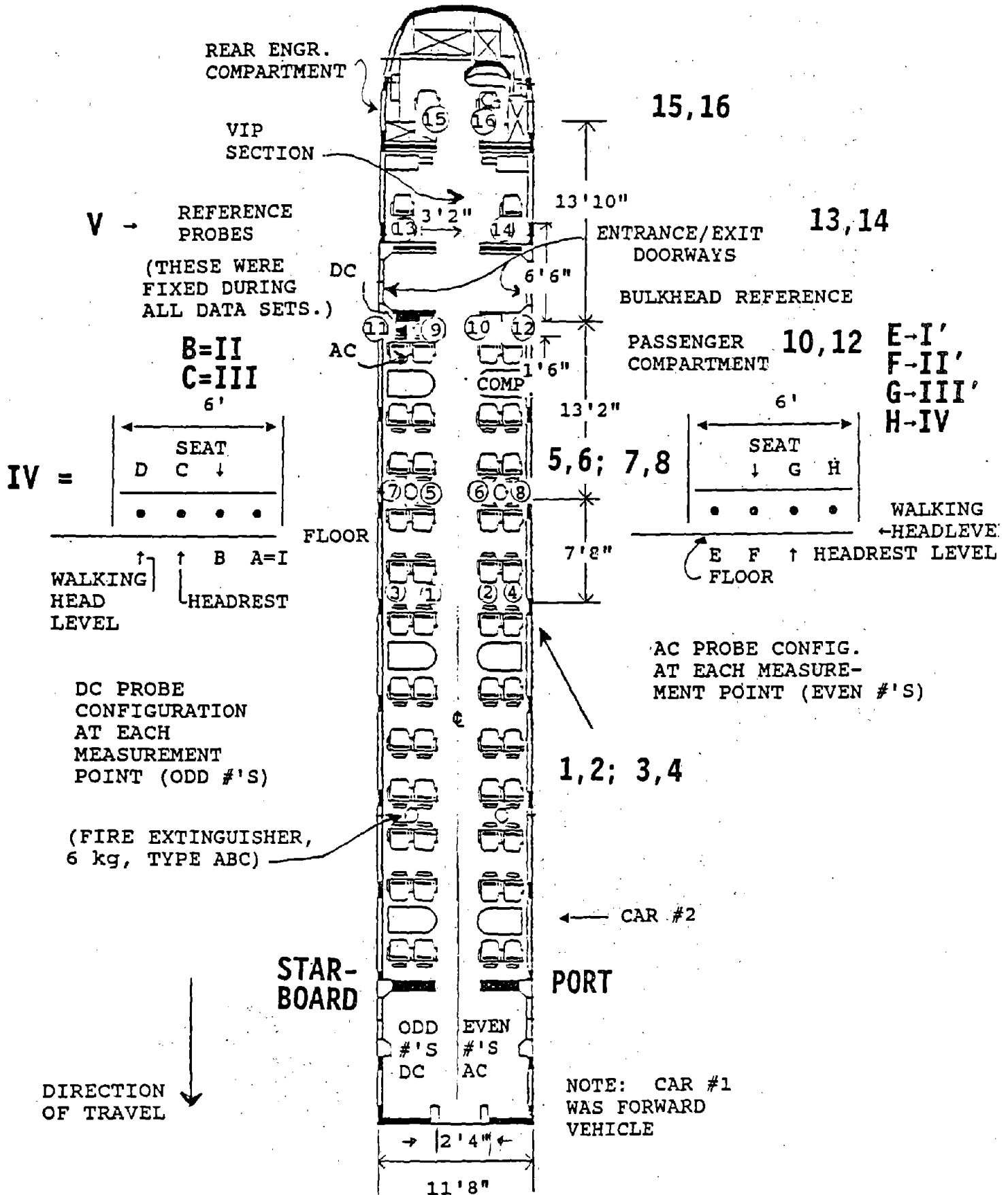

VEHICLE SPEED - TR7002

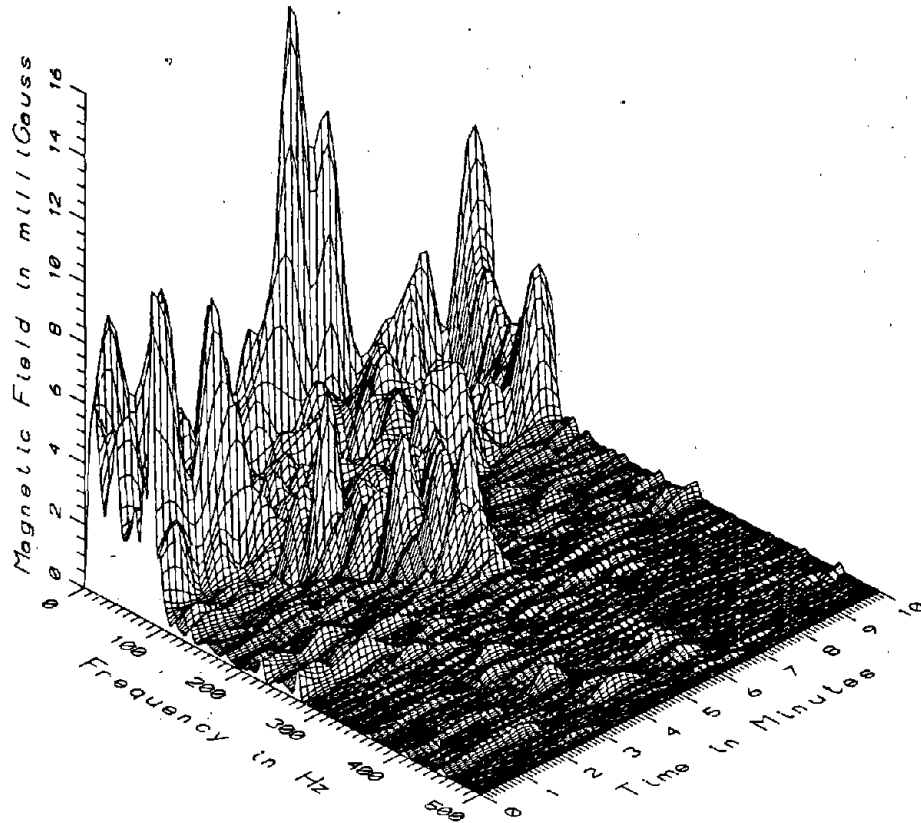
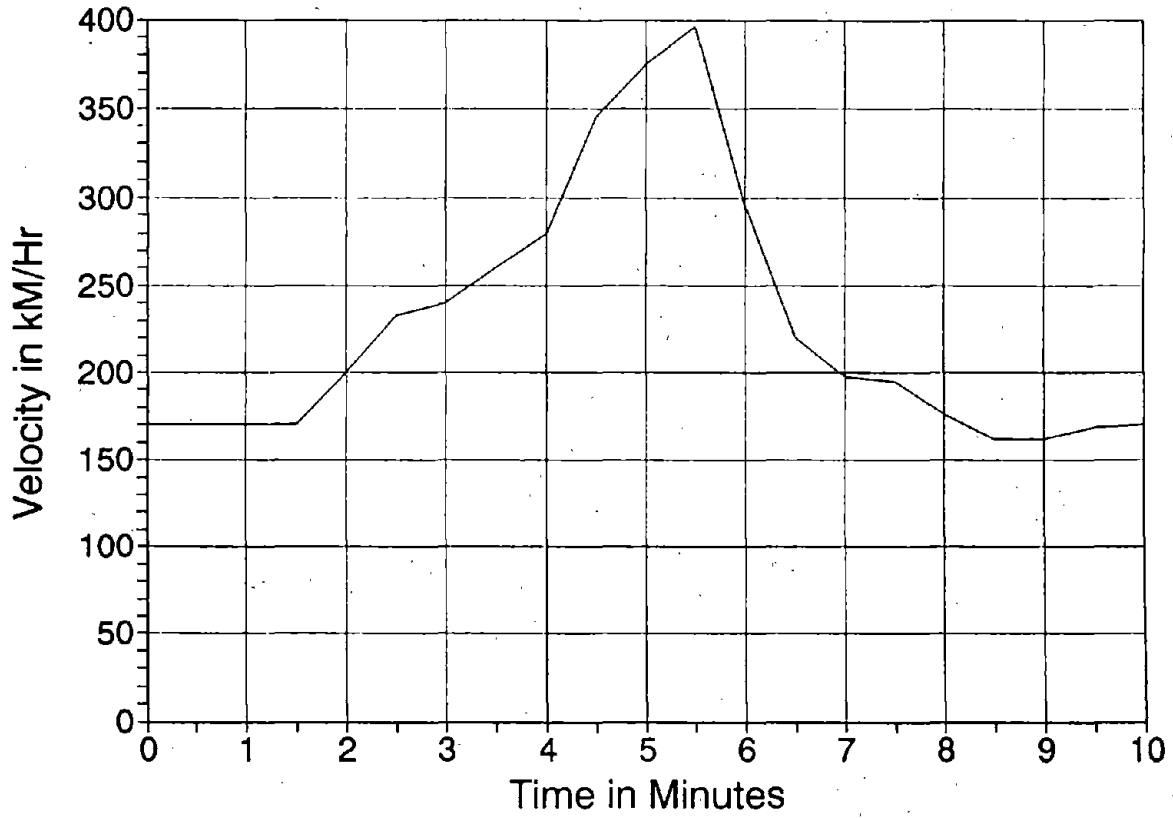

TR7002 - STANDING HEAD LEVEL - AISLE SEAT IN MIDDLE OF PASSENGER SECTION, CAR#

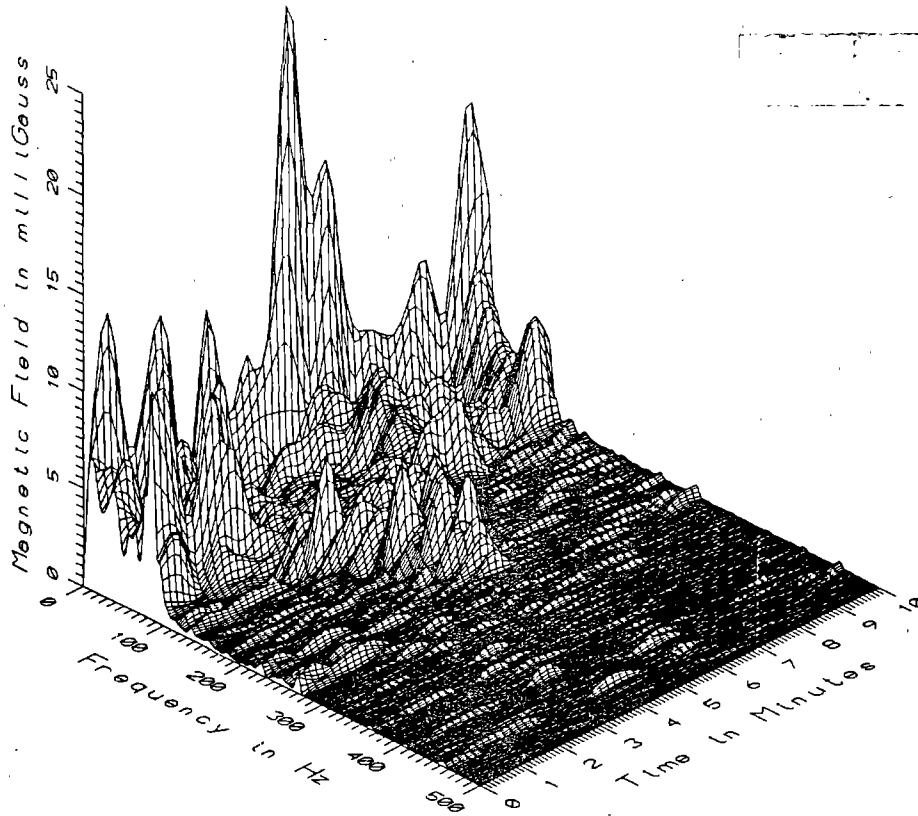

TR7002 - SEATED HEAD LEVEL - AISLE SEAT IN MIDDLE OF PASSENGER SECTION, CAR#2

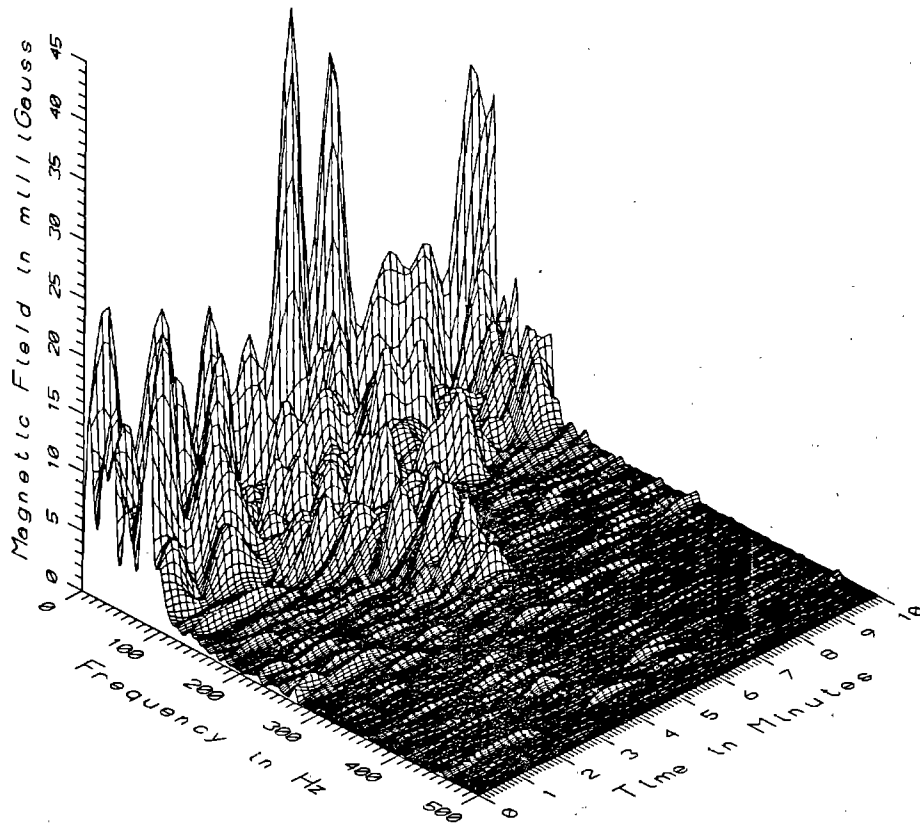

TR7002 - SEAT LEVEL - AISLE SEAT IN MIDDLE OF PASSENGER SECTION, CAR#2

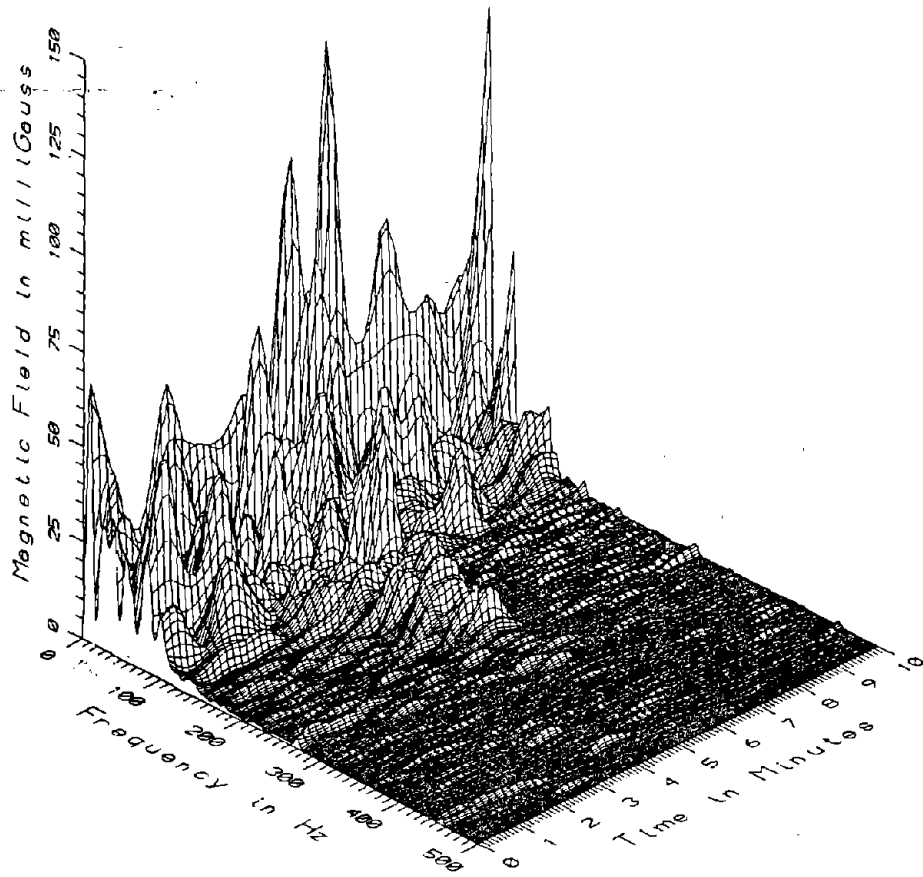

TR7002 - FLOOR LEVEL - AISLE SEAT IN MIDDLE OF PASSENGER SECTION, CAR#2

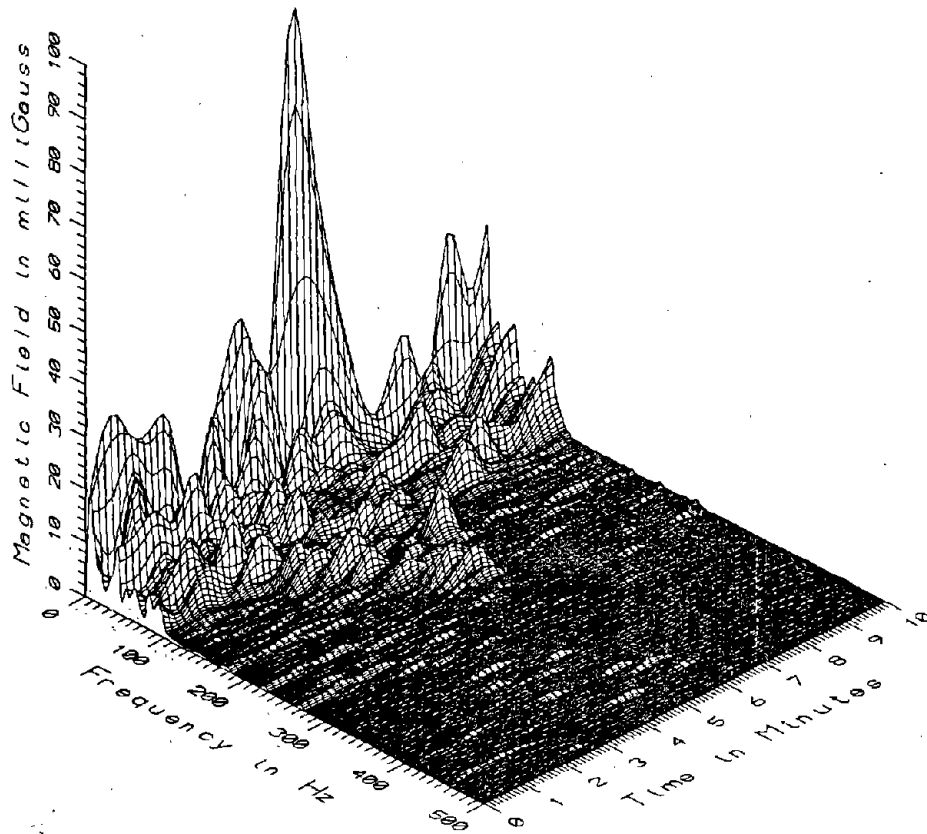

TR7002 - REFERENCE PROBE - BULKHEAD IN REAR OF PASSENGER SECTION, CAR#2

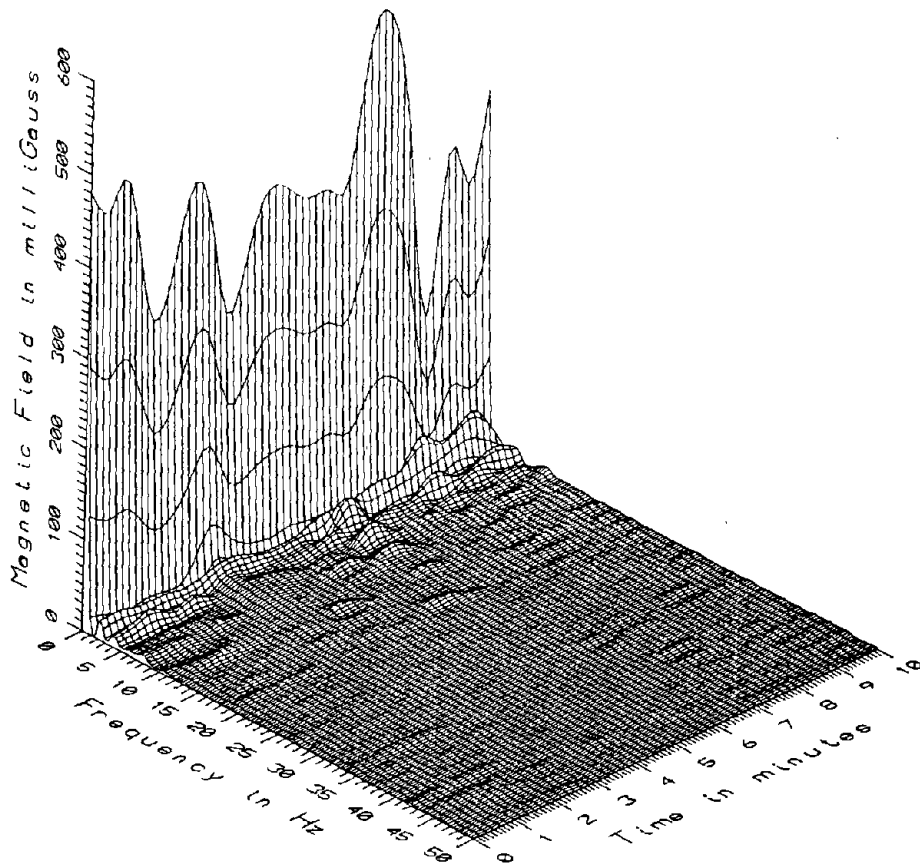

TR7002 - STANDING HEAD LEVEL - AISLE SEAT IN MIDDLE OF PASSENGER SECTION, CAR#

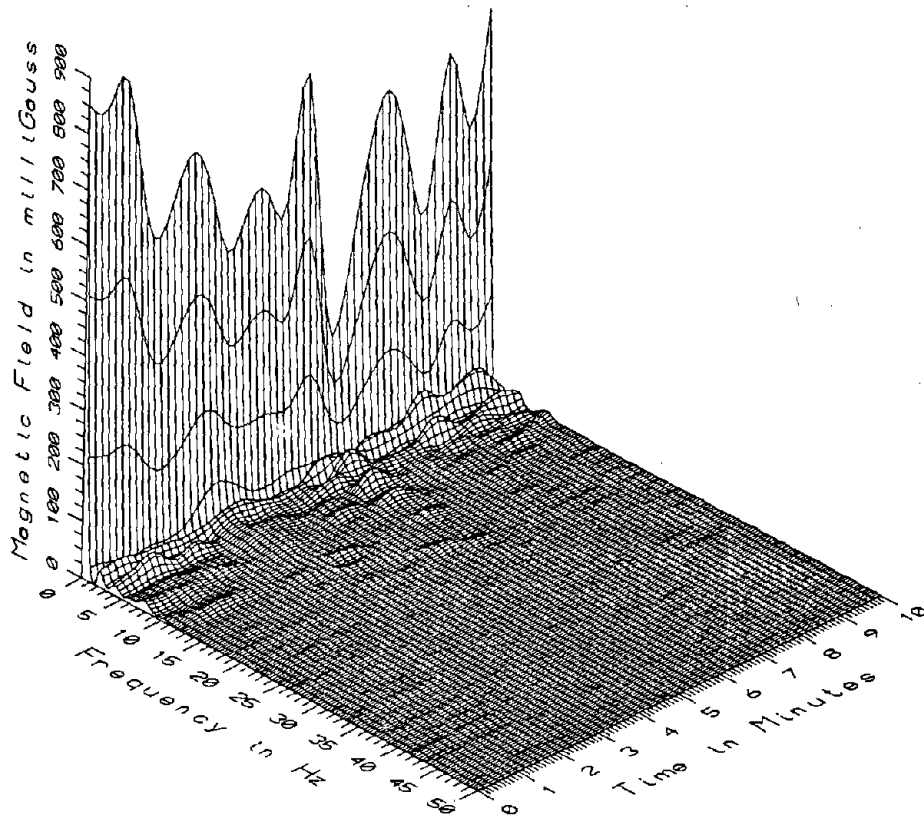

TR7002 - SEATED HEAD LEVEL - AISLE SEAT IN MIDDLE OF PASSENGER SECTION, CAR#

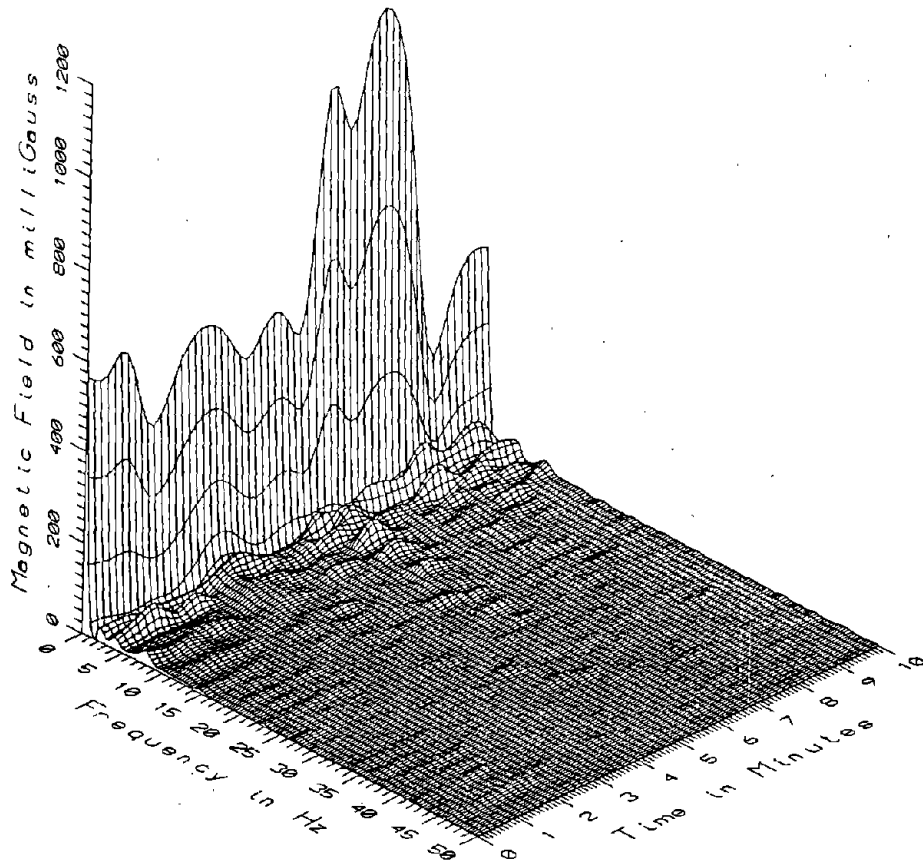

TR7002 - SEAT LEVEL - AISLE SEAT IN MIDDLE OF PASSENGER SECTION, CAR#2

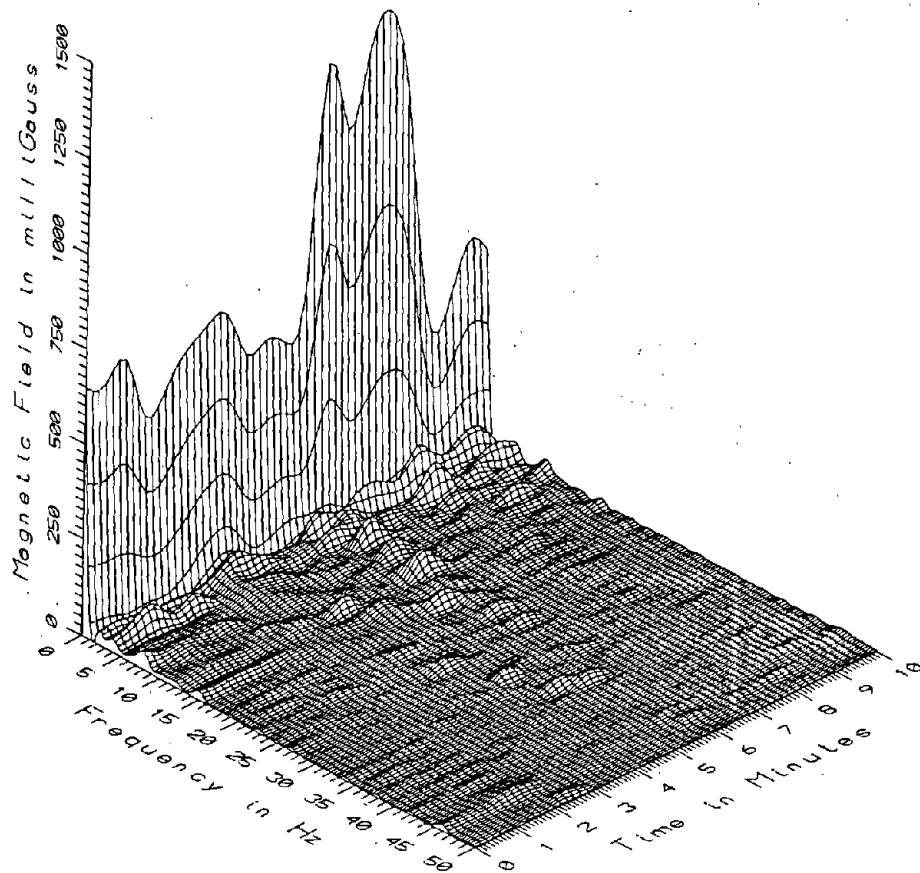

TR7002 - FLOOR LEVEL - AISLE SEAT IN MIDDLE OF PASSENGER SECTION, CAR#2

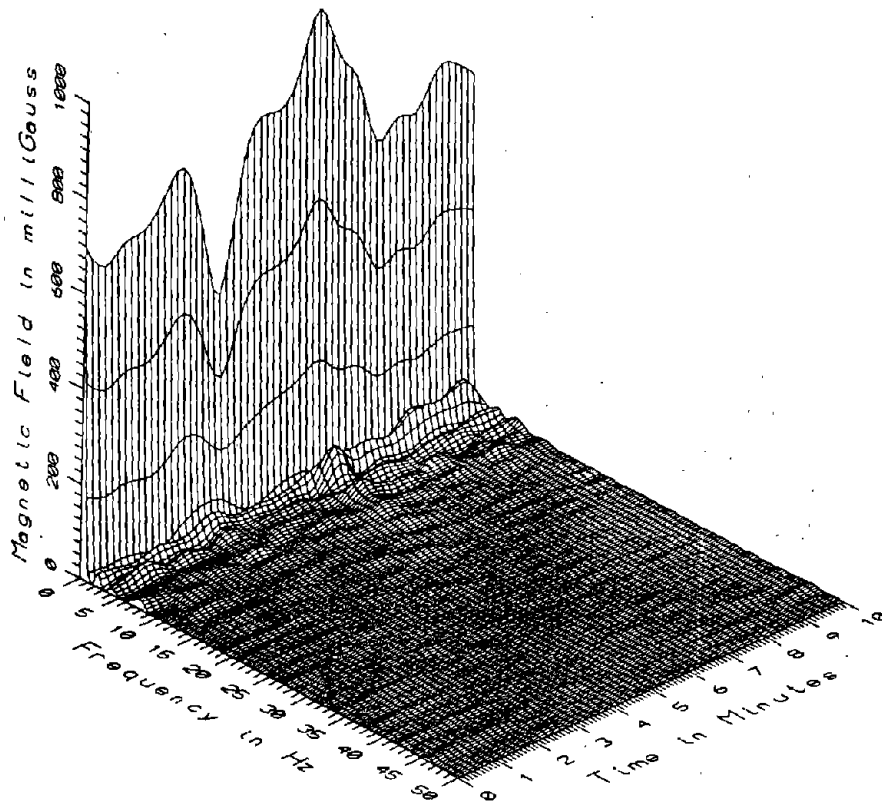

TR7002 - REFERENCE PROBE - BULKHEAD IN REAR OF PASSENGER SECTION, CAR#2

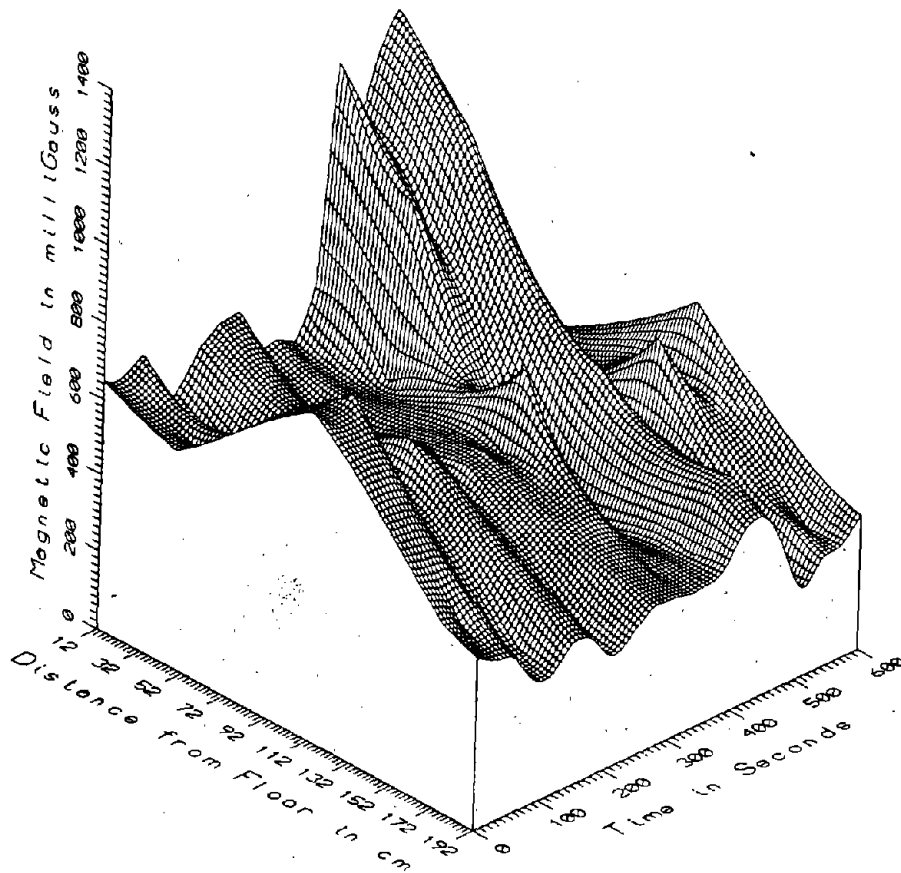

TR7002 - AISLE SEAT IN MIDDLE OF PASSENGER SECTION, CAR2 - DC

C-8

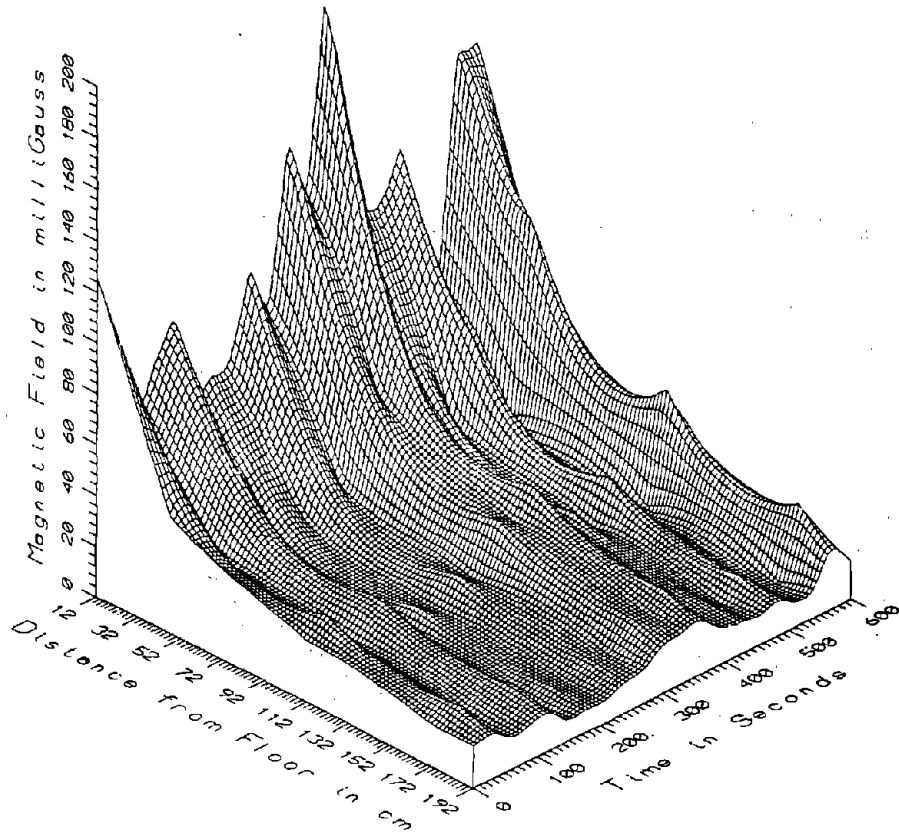

TR7002, AISLE SEAT IN MIDDLE OF PASSENGER SECTION, CAR2 - LOW FREQUENCY, 5-45Hz

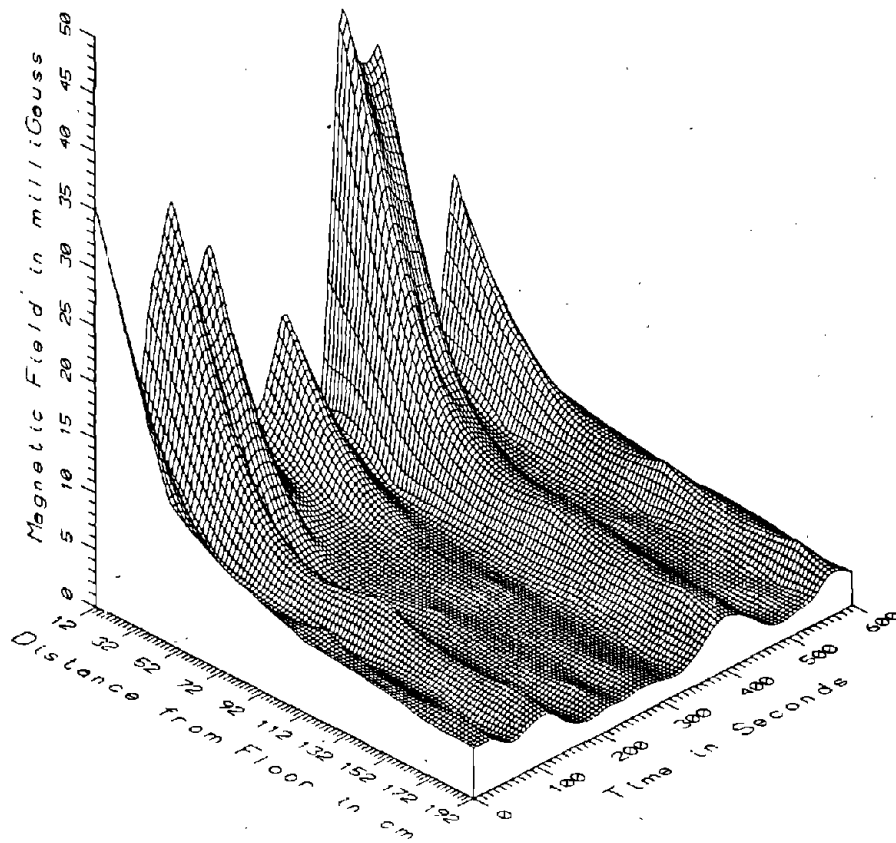

TR7002, AISLE SEAT IN MIDDLE OF PASSENGER SECTION, CAR2 - POWER FREQ, 50-60Hz

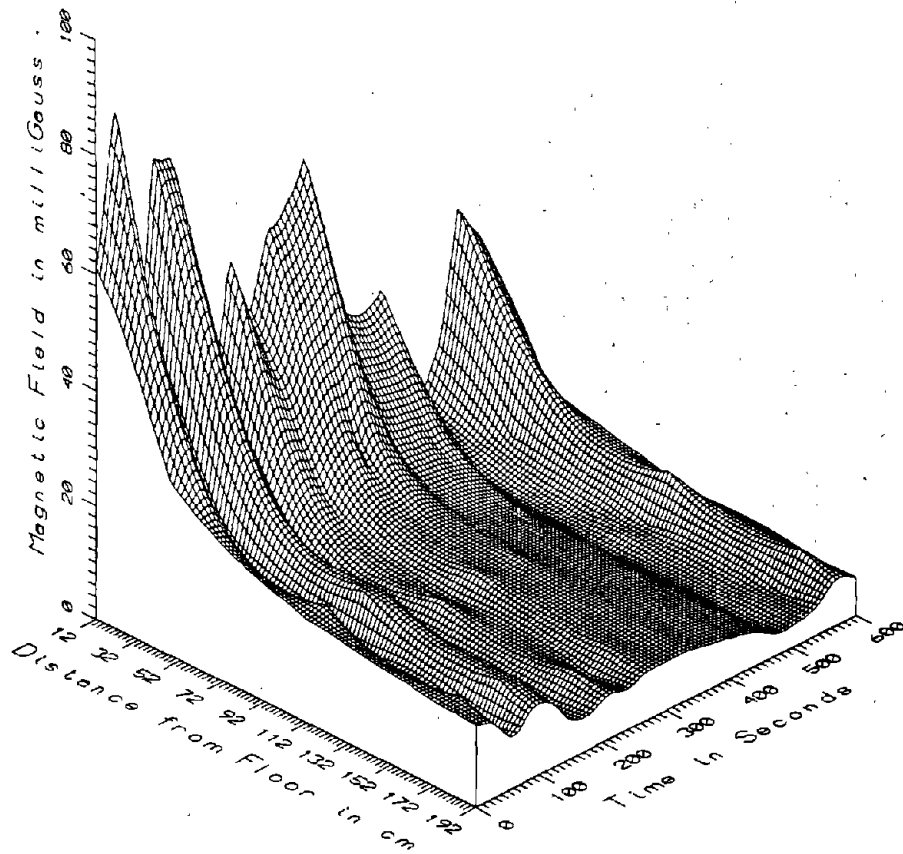

TR7002, AISLE SEAT IN MIDDLE OF PASSENGER SECTION, CAR2 - POWER HARM. 65-300Hz

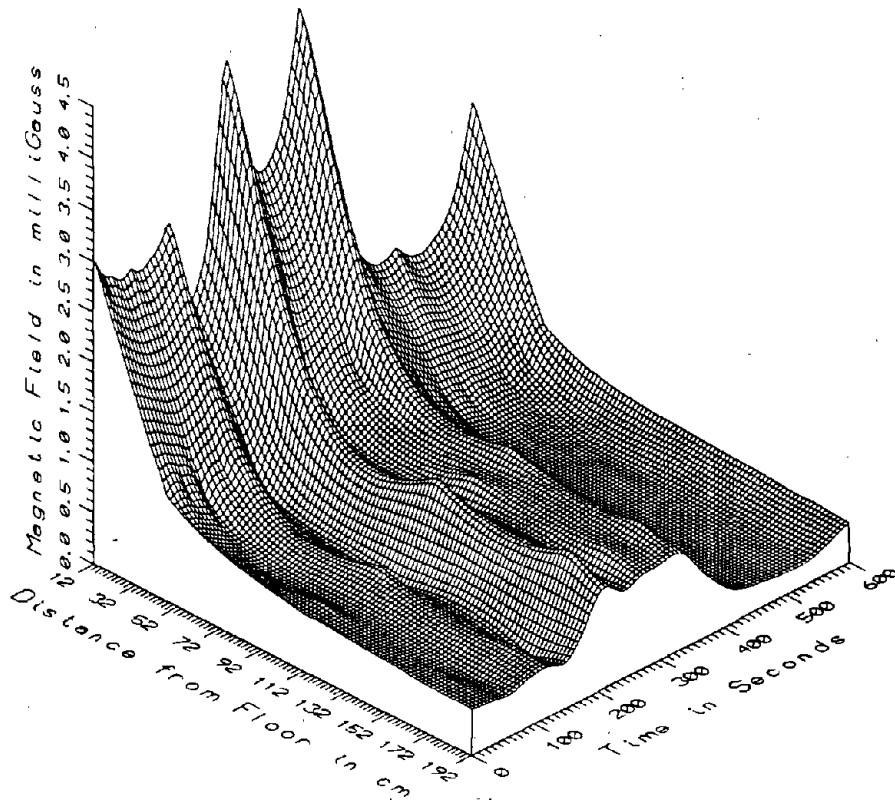

TR7002, AISLE SEAT IN MIDDLE OF PASSENGER SECTION, CAR2 - HIGH FREQ. 305-2560Hz

C-11

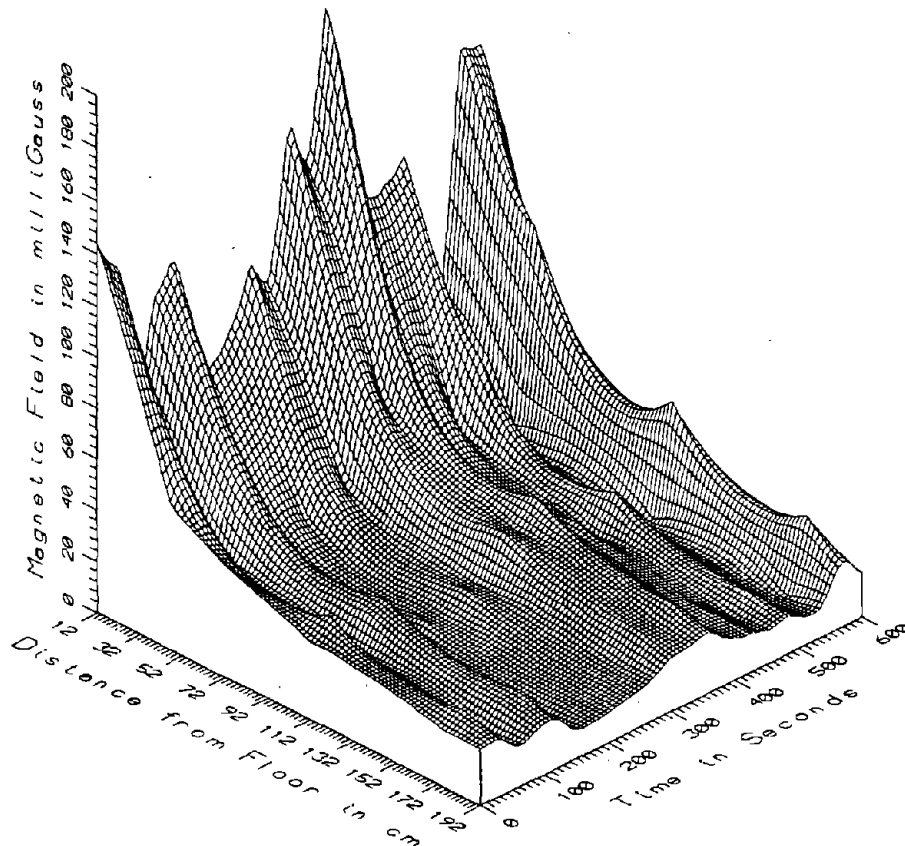

TR7002. AISLE SEAT IN MIDDLE OF PASSENGER SECTION. CAR2 - ALL FREQ. 5-2560Hz

D-1

APPENDIX D

DATA SET TR7003

**VEHICLE PASSENGER SECTION,
AISLE SEAT, MID CAR**

APPENDIX D

DATA SET TR7003
VEHICLE PASSENGER SECTION, AISLE SEAT, MID CAR

Measurement Setup Code: 2 (coil-type) & 1 (fluxgate-type)
Vehicle Status: Running continuously
Measurement Date: August 7, 1990
Measurement Time: Start: 13:30:00
End: 13:40:00
Number of Samples: 17
Programmed Sample Interval: 30 sec
Actual Sample Interval: 35 sec

Frequency Spectrum Parameters

<u>Probe Type:</u>	<u>Coil (AC)</u>	<u>Fluxgate (DC)</u>
Maximum Frequency (Hz)	2560	102.4
Minimum Frequency (Hz)	5	0
Spectral Bandwidth (Hz)	5	0.2

Missing or Suspect Data: None

ON-VEHICLE MEASUREMENT POINTS (AUG. 7, '90)

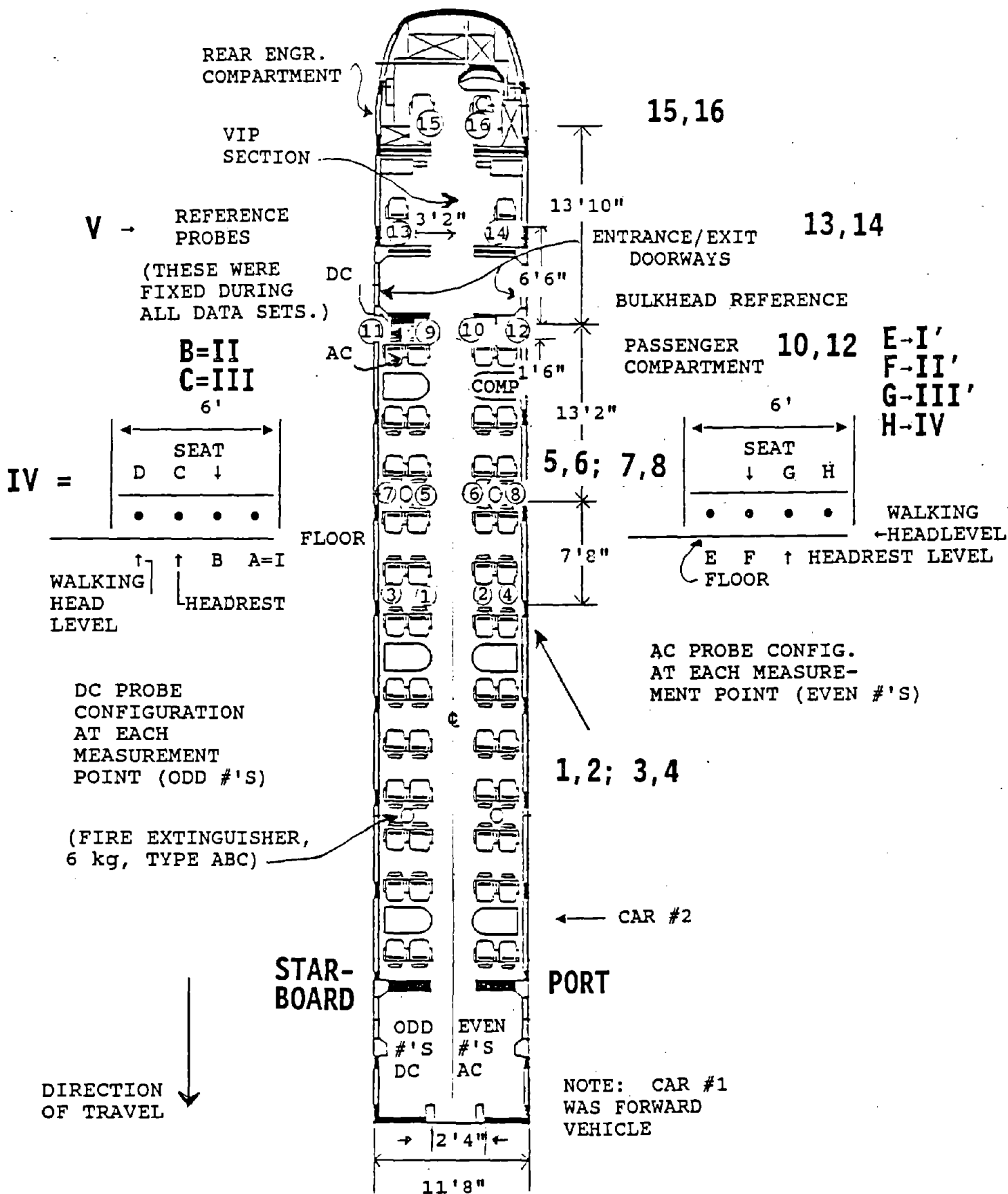

VEHICLE SPEED - TR7003

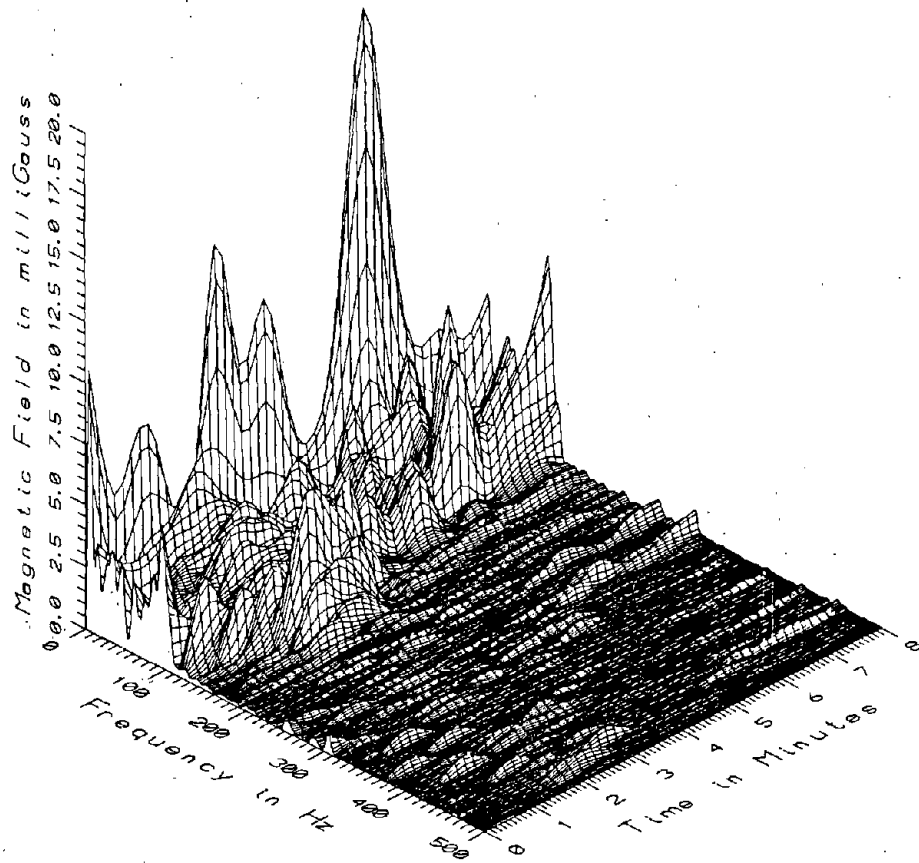
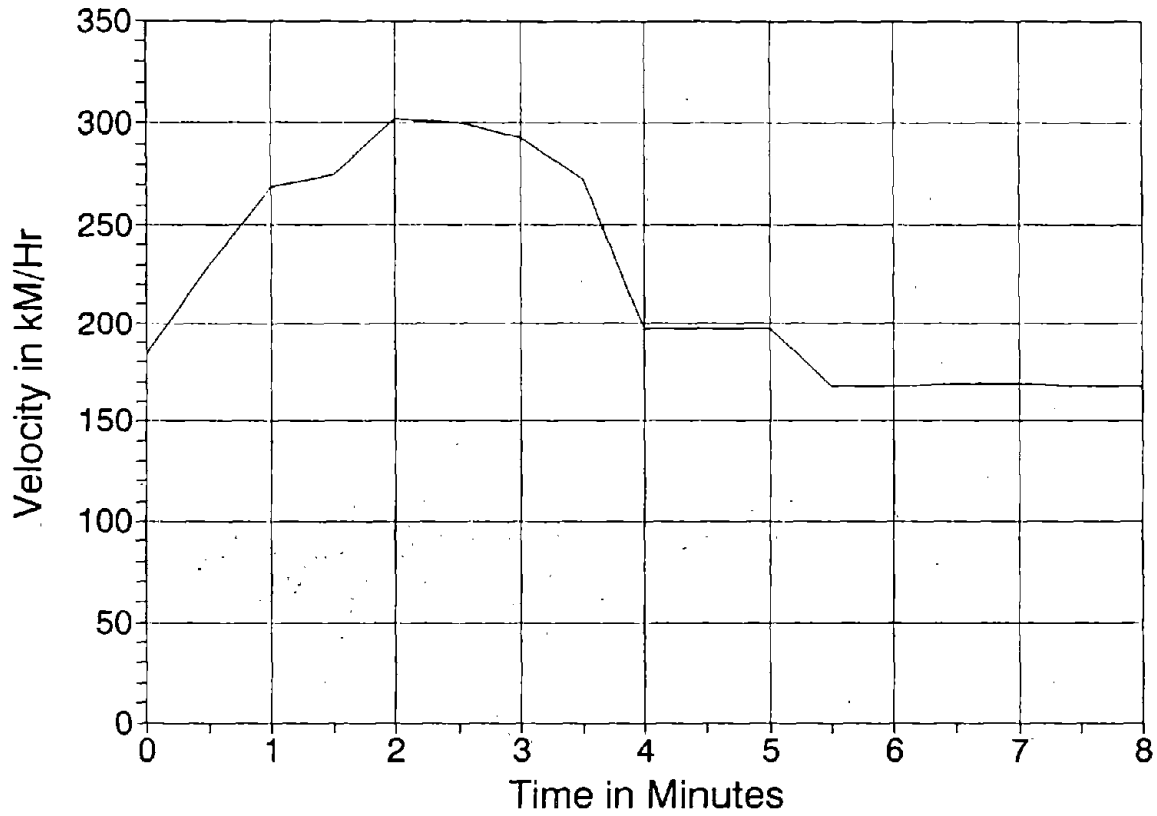

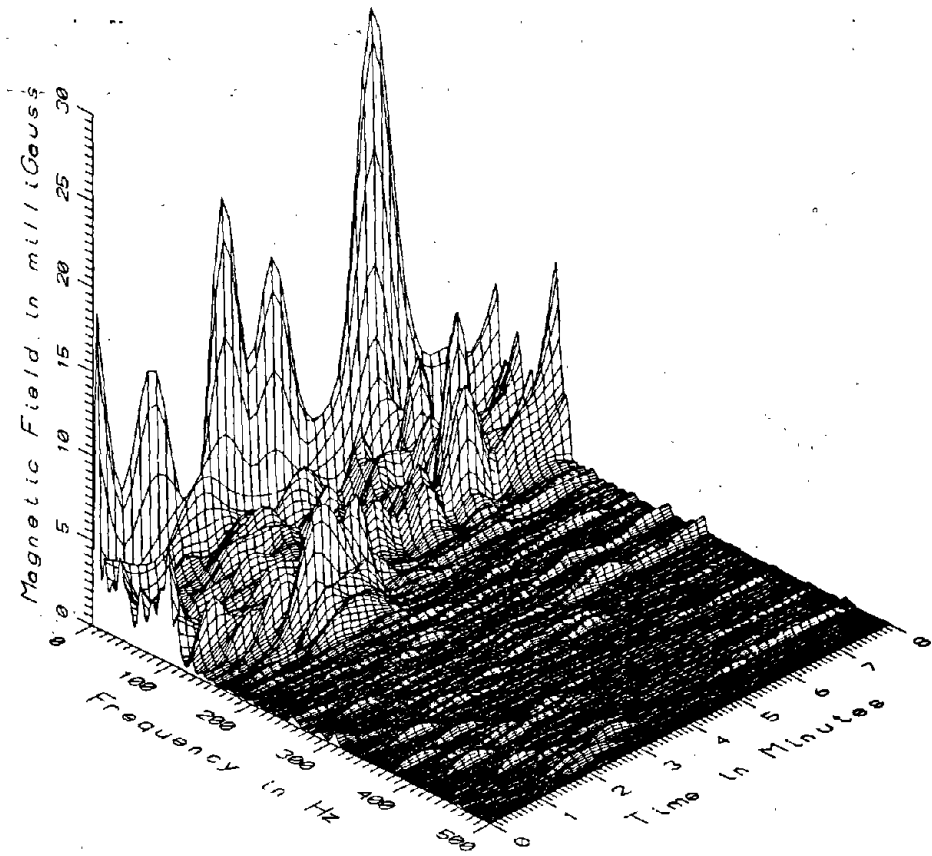

TR7003 - SEATED HEAD LEVEL - AISLE SEAT IN MIDDLE OF PASSENGER SECTION, CAR#2

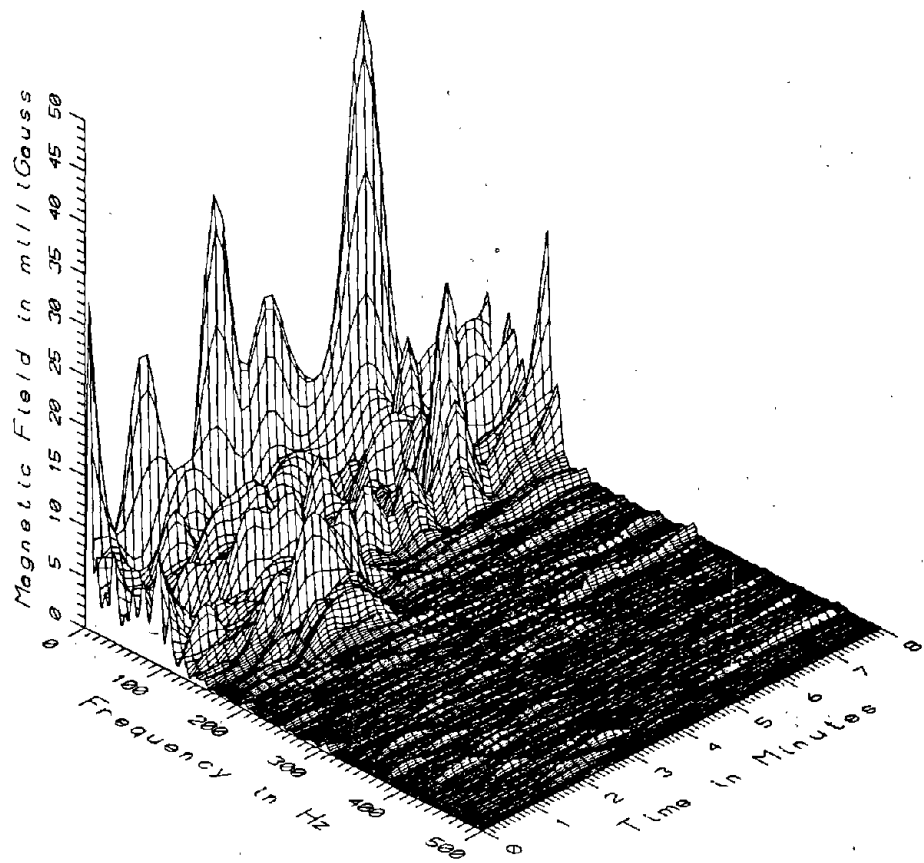

TR7003 - SEAT LEVEL - AISLE SEAT IN MIDDLE OF PASSENGER SECTION, CAR#2

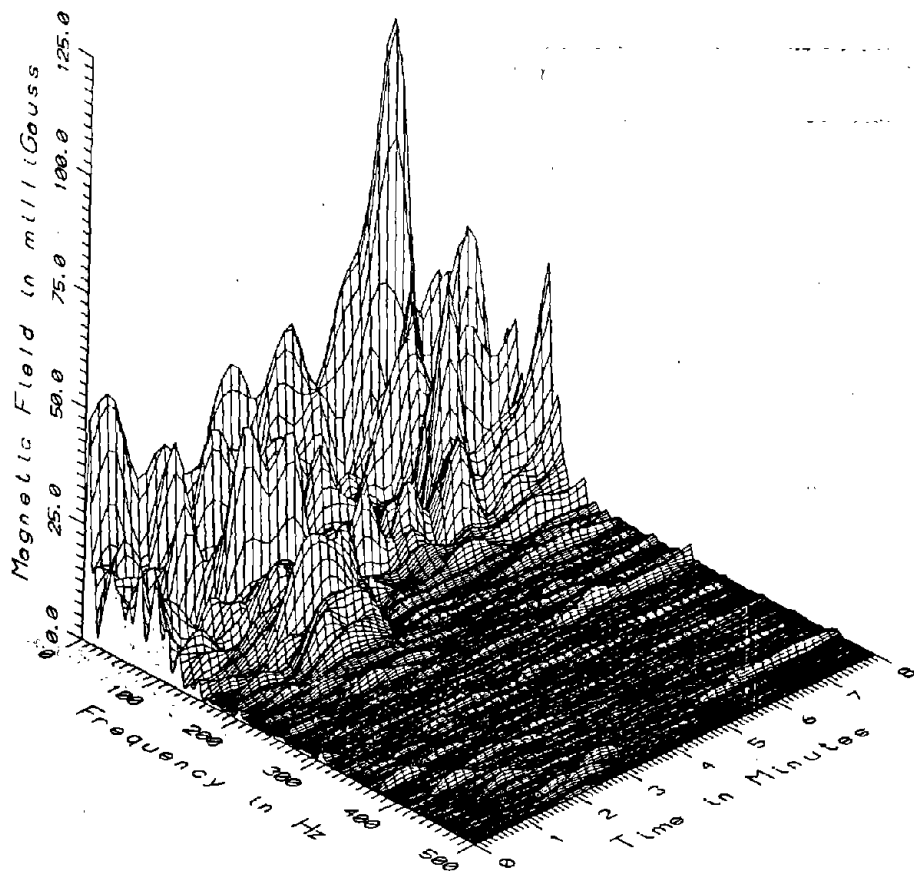

TR7003 - FLOOR LEVEL - AISLE SEAT IN MIDDLE OF PASSENGER SECTION, CAR#2

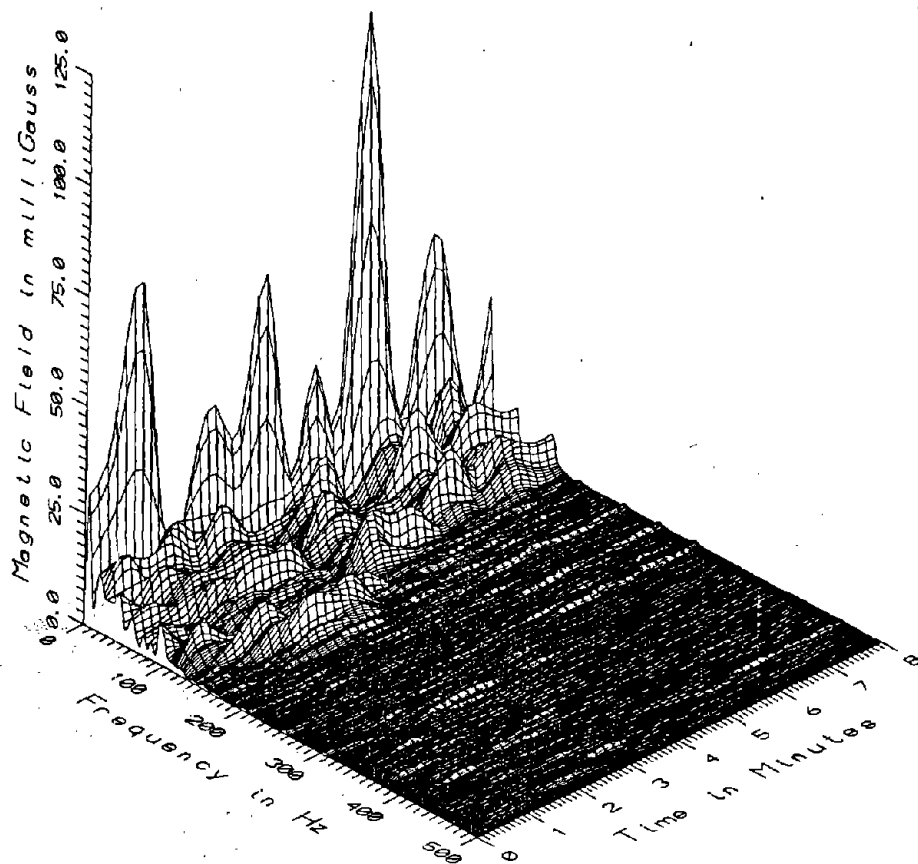

TR7003 - REFERENCE PROBE - BULKHEAD IN REAR OF PASSENGER SECTION, CAR#2

D-5

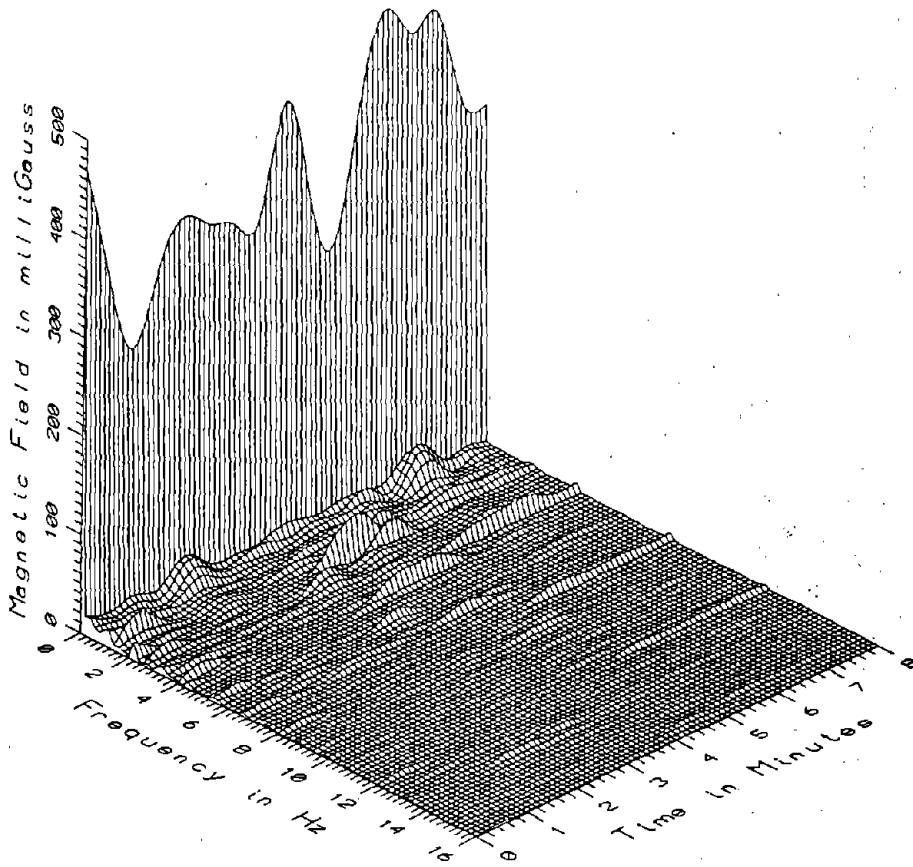

TR7003 - STANDING HEAD LEVEL - AISLE SEAT IN MIDDLE OF PASSENGER SECTION, CAR#2

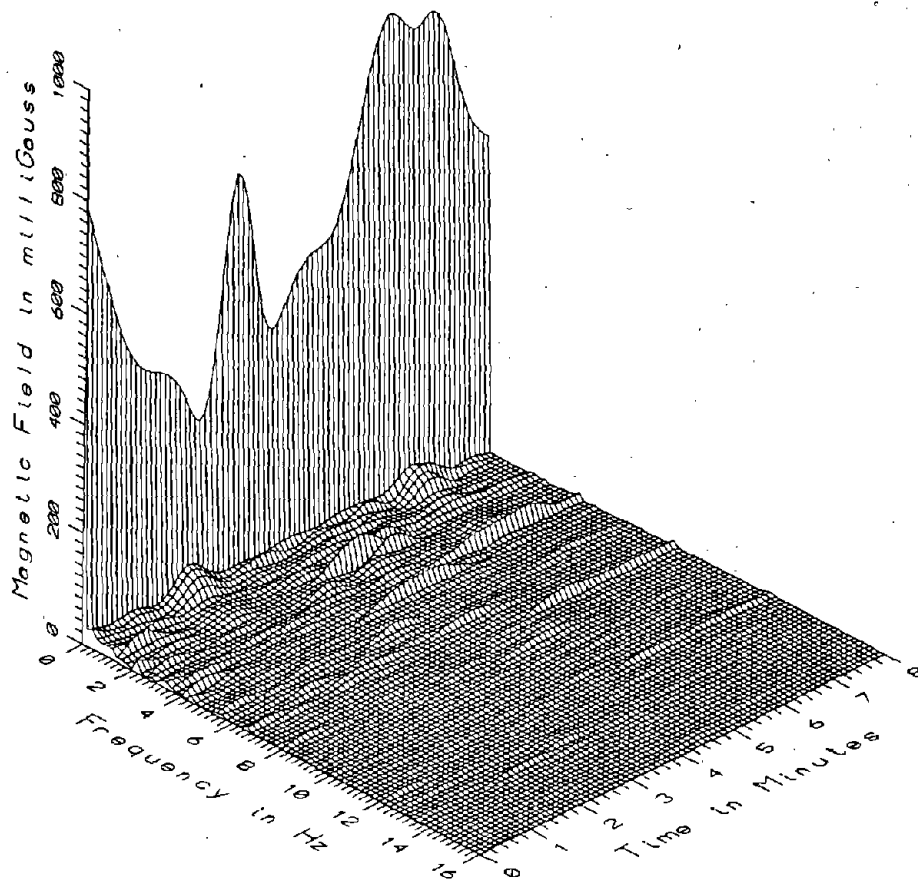

TR7003 - SEATED HEAD LEVEL - AISLE SEAT IN MIDDLE OF PASSENGER SECTION, CAR#2

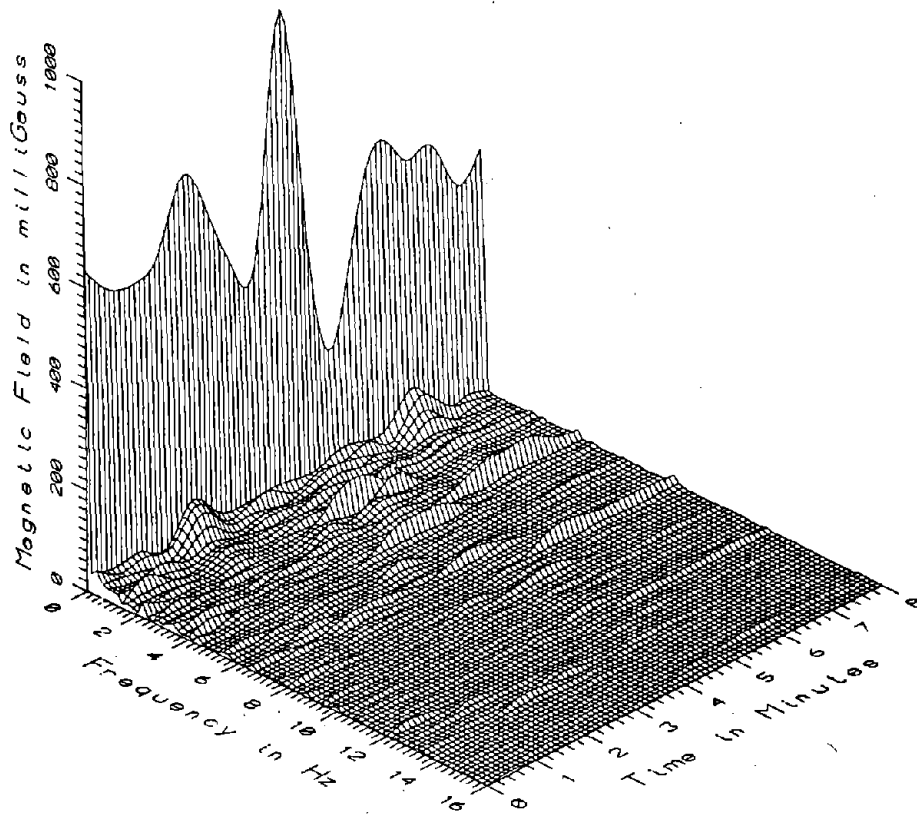

TR7003 - SEAT LEVEL - AISLE SEAT IN MIDDLE OF PASSENGER SECTION, CAR#2

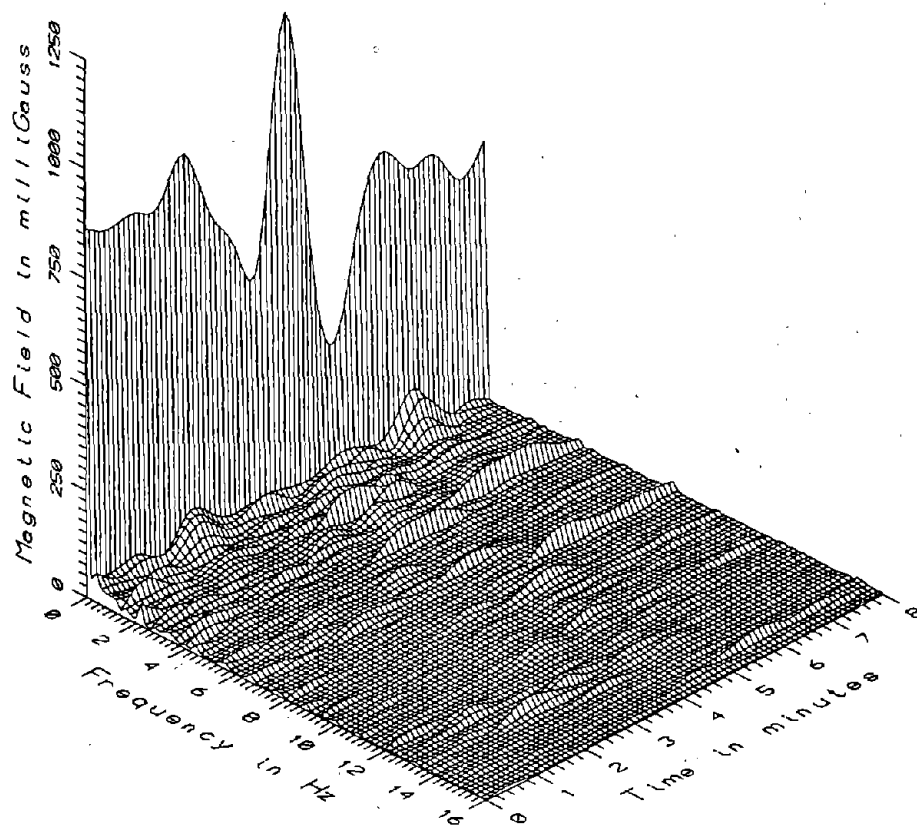

TR7003 - FLOOR LEVEL - AISLE SEAT IN MIDDLE OF PASSENGER SECTION, CAR#2

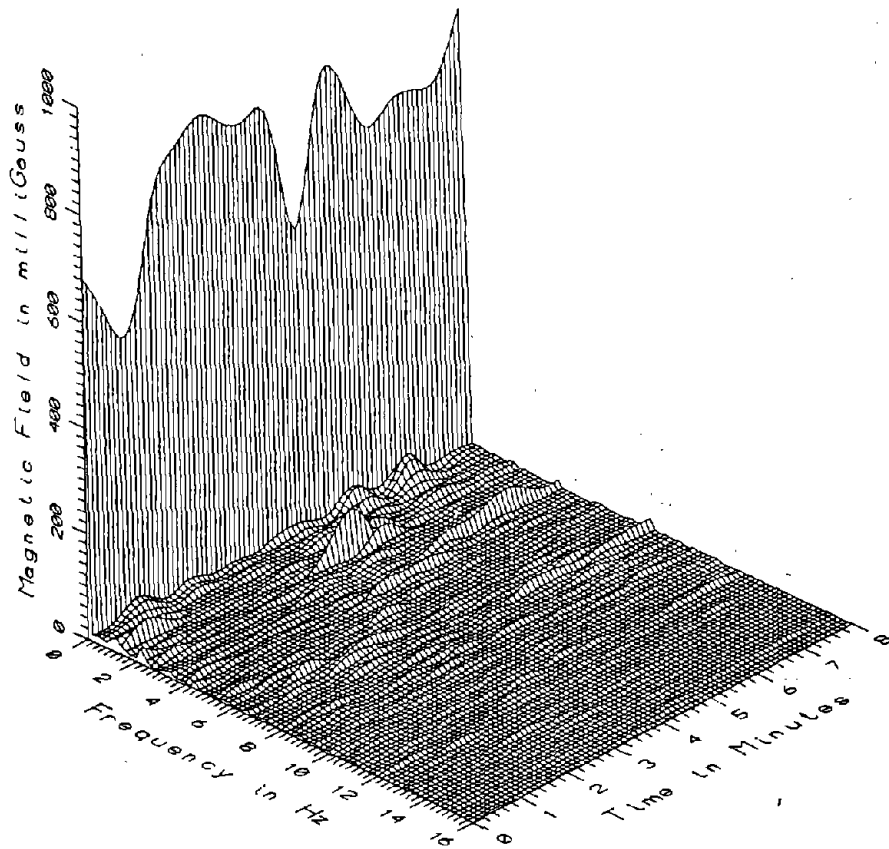

TR7003 - REFERENCE PROBE - BULKHEAD IN REAR OF PASSENGER SECTION, CAR#2

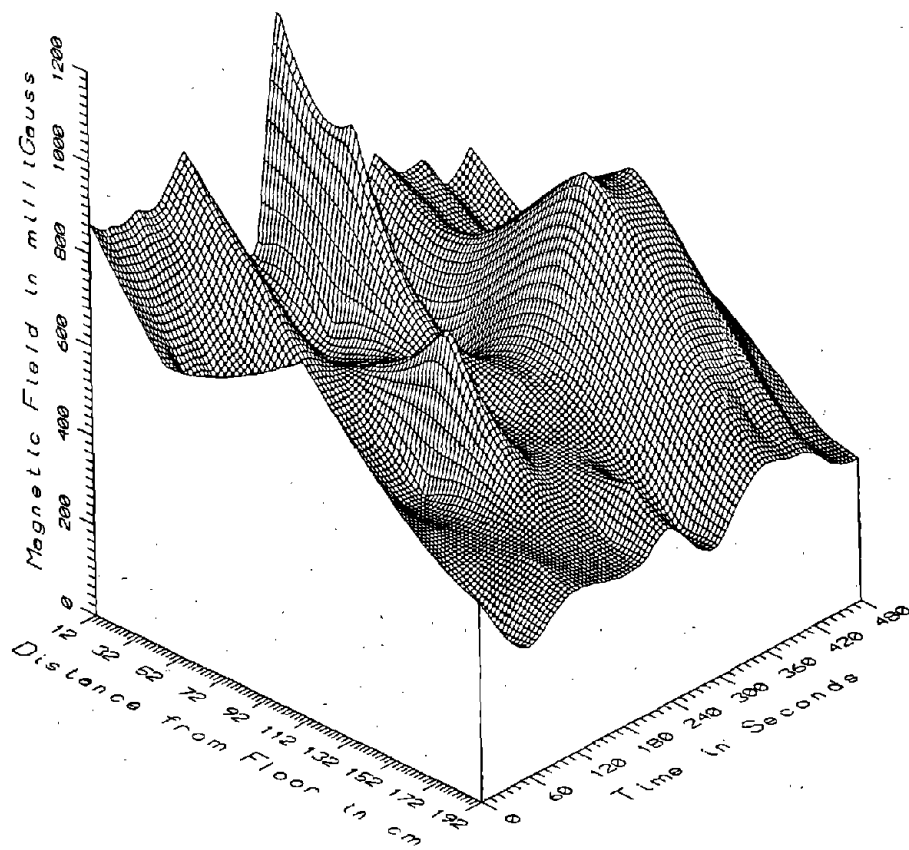

TR7003 - AISLE SEAT IN MIDDLE OF PASSENGER SECTION, CAR2 - DC

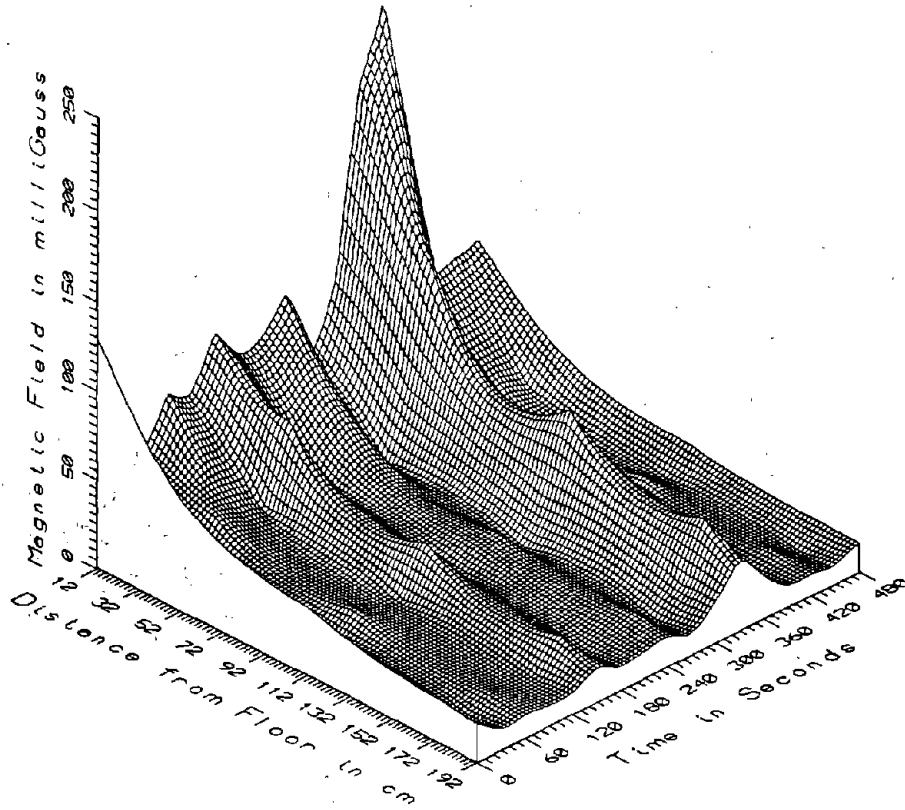

TR7003. AISLE SEAT IN MIDDLE OF PASSENGER SECTION, CAR2 - LOW FREQ, 5-45Hz

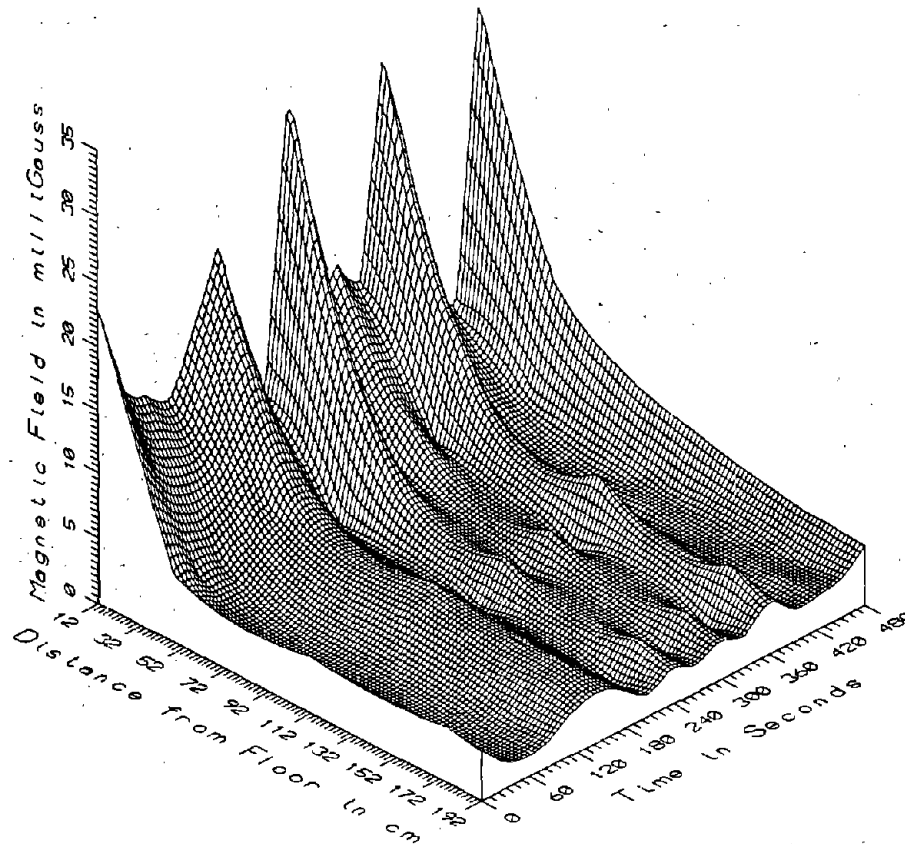

TR7003. AISLE SEAT IN MIDDLE OF PASSENGER SECTION, CAR2 - POWER FREQ, 50-60Hz

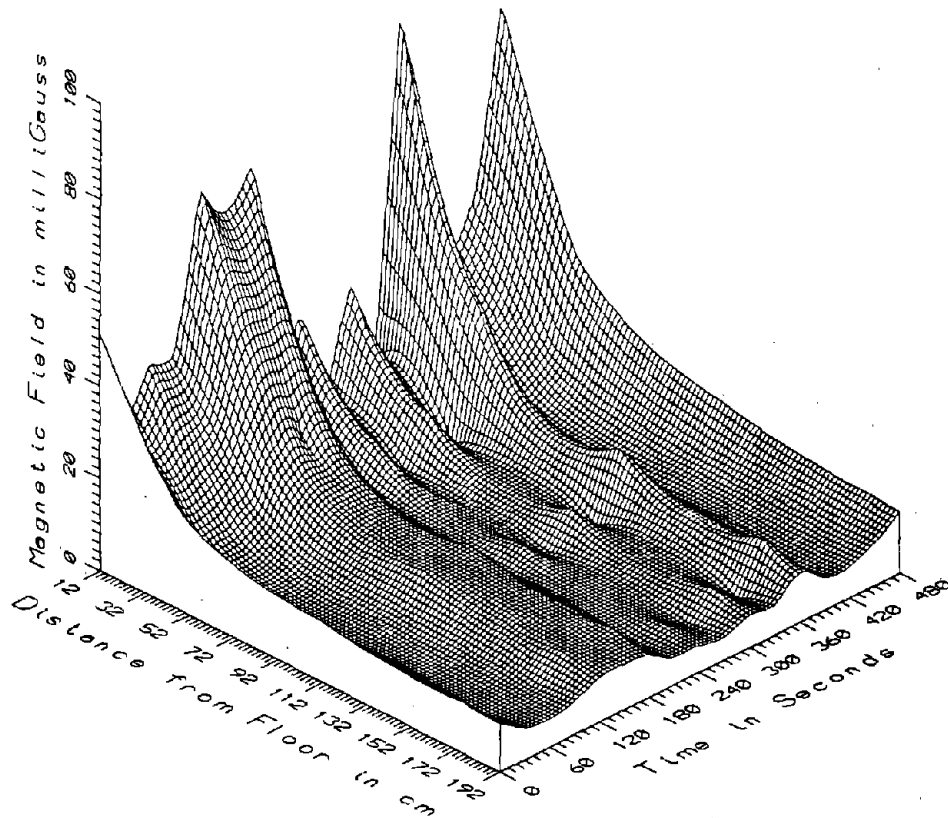

TR7003, AISLE SEAT IN MIDDLE OF PASSENGER SECTION, CAR2 - POWER HARM. 65-300Hz

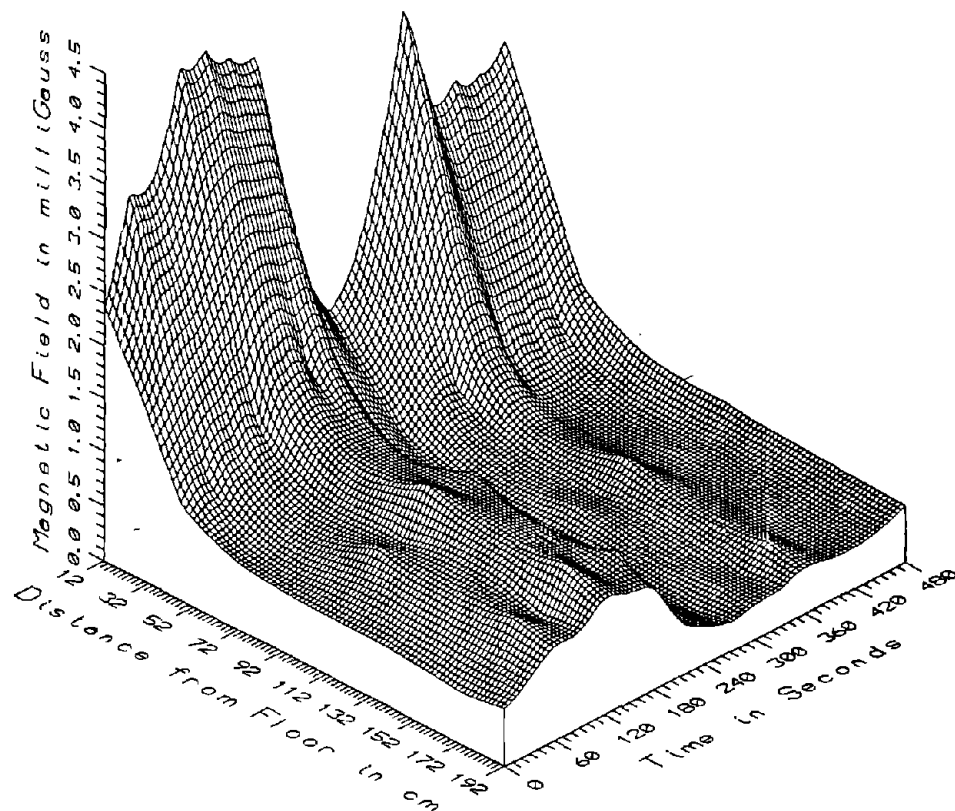

TR7003, AISLE SEAT IN MIDDLE OF PASSENGER SECTION, CAR2 - HIGH FREQ. 305-2560Hz

D-11

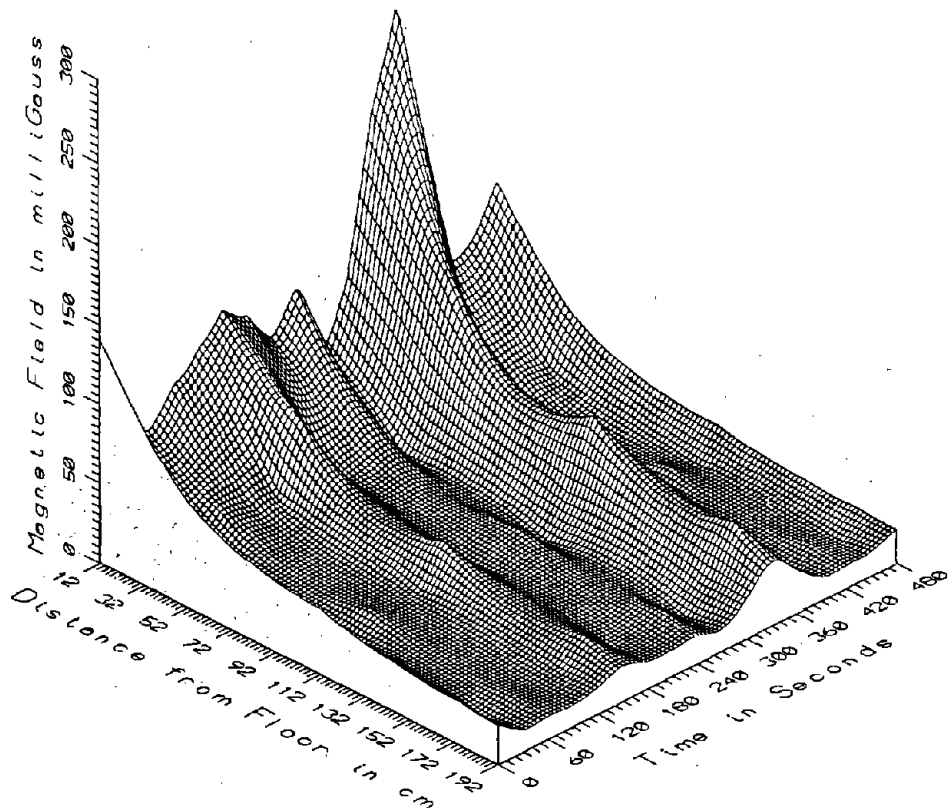

TR7003, AISLE SEAT IN MIDDLE OF PASSENGER SECTION, CAR2 - ALL FREQ. 5-2560Hz

E-1

APPENDIX E

DATA SET TR7008

**VEHICLE PASSENGER SECTION,
WINDOW SEAT, LAST ROW**

APPENDIX E

DATA SET TR7008
VEHICLE PASSENGER SECTION, WINDOW SEAT, LAST ROW

Measurement Setup Code: 12 (coil-type) & 11 (fluxgate-type)
Vehicle Status: Running continuously
Measurement Date: August 7, 1990
Measurement Time: Start: 17:35:00
End: 17:44:00
Number of Samples: 19
Programmed Sample Interval: 30 sec
Actual Sample Interval: 30 sec

Frequency Spectrum Parameters

<u>Probe Type:</u>	<u>Coil (AC)</u>	<u>Fluxgate (DC)</u>
Maximum Frequency (Hz)	2560	102.4
Minimum Frequency (Hz)	5	0
Spectral Bandwidth (Hz)	5	0.2

Missing or Suspect Data: The floor level fluxgate sensor saturated on the vertical axis for the last 3 of the 19 samples.

ON-VEHICLE MEASUREMENT POINTS (AUG. 7, '90)

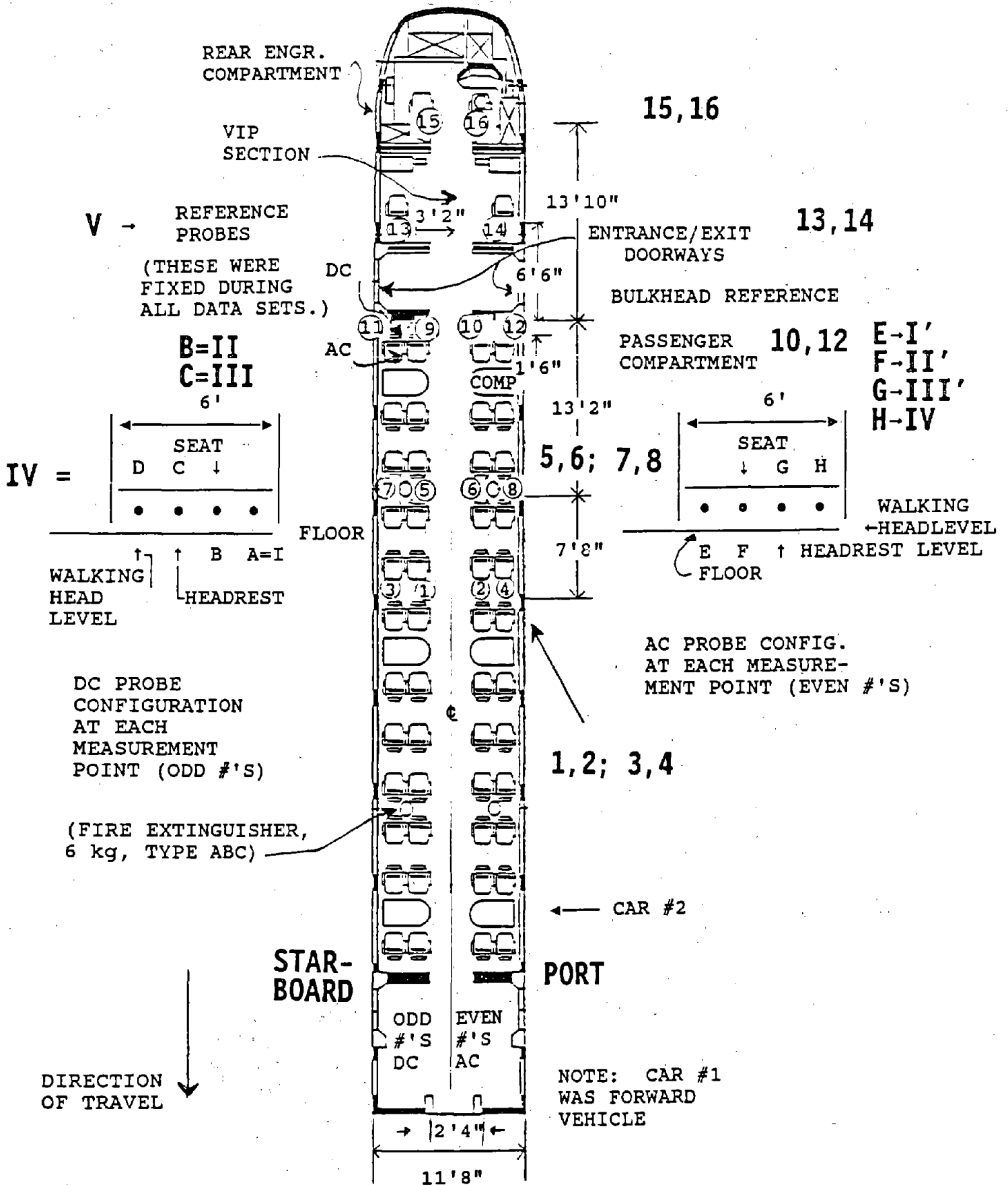

VEHICLE SPEED - TR7008

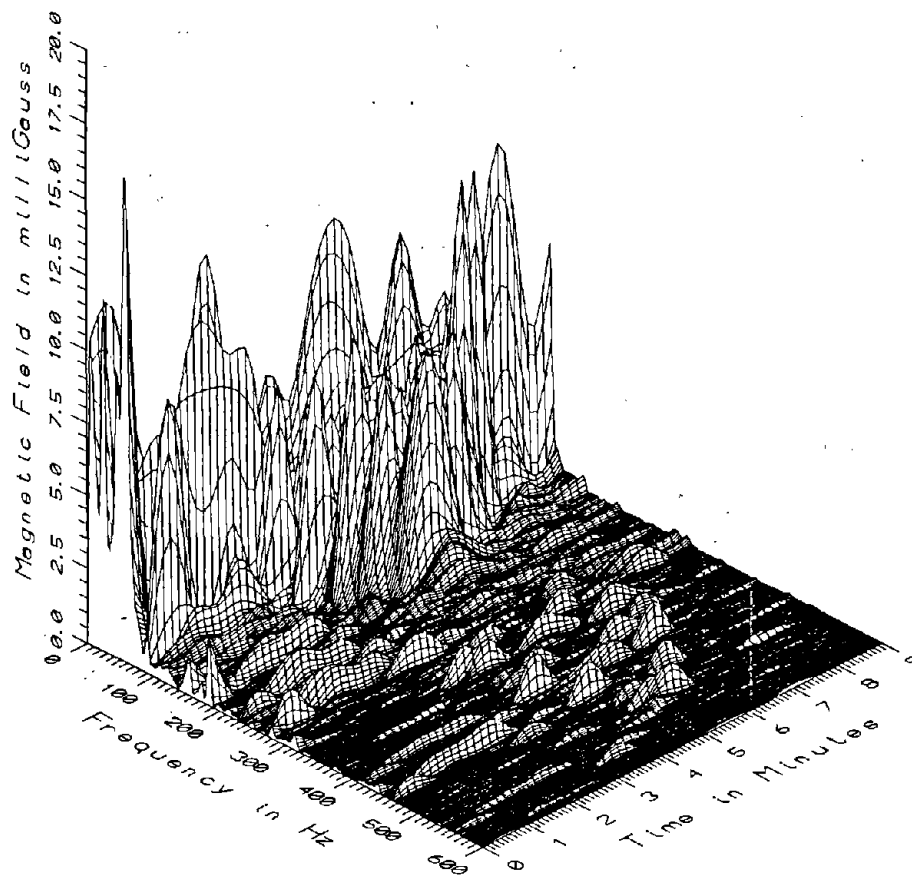
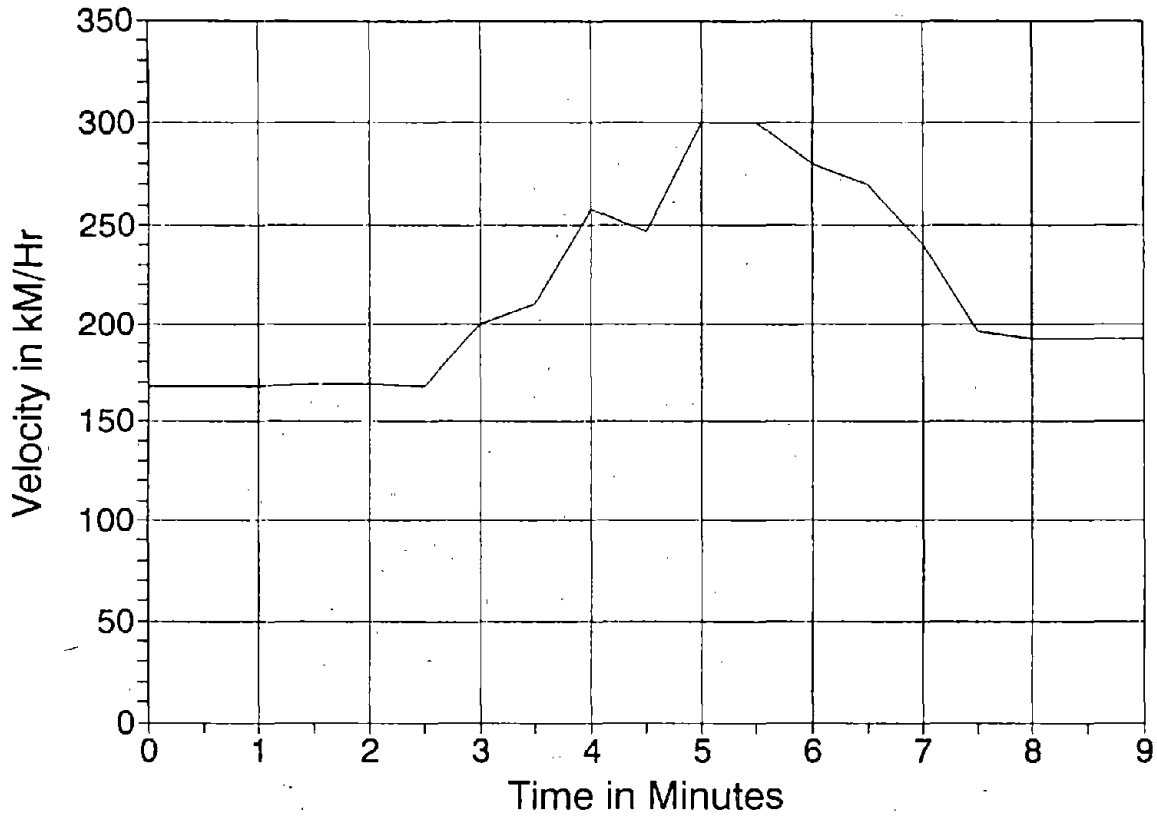

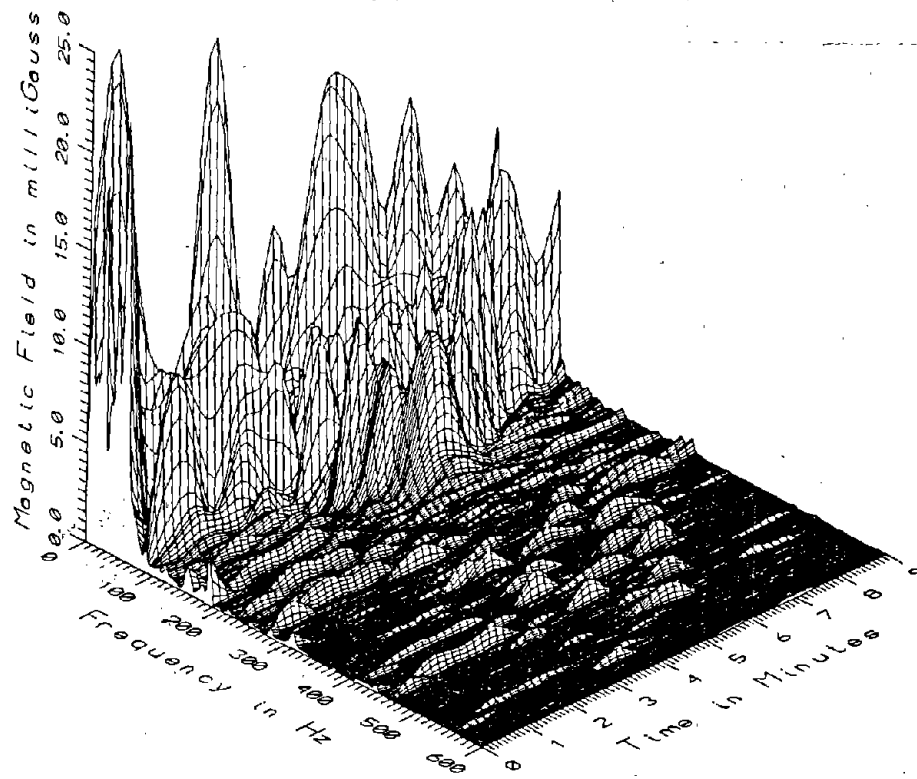

TR7008 - SEATED HEAD LEVEL - WINDOW SEAT IN REAR OF PASSENGER SECTION, CAR#2

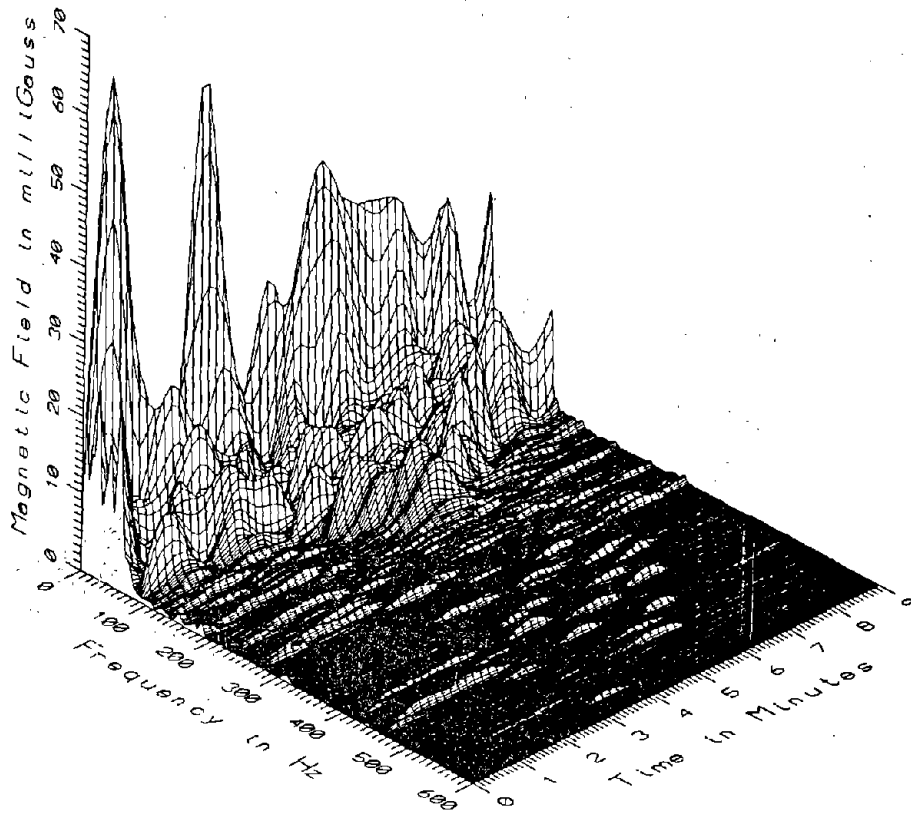

TR7008 - SEAT LEVEL - WINDOW SEAT IN REAR OF PASSENGER SECTION, CAR#2

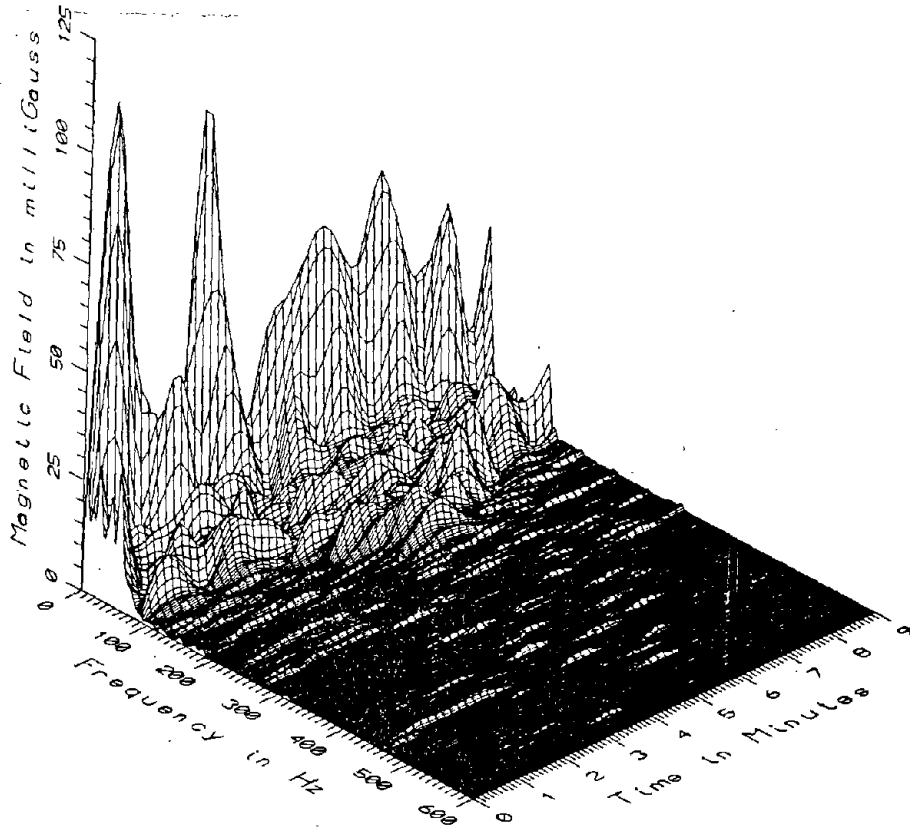

TR7008 - FLOOR LEVEL - WINDOW SEAT IN REAR OF PASSENGER SECTION, CAR#2

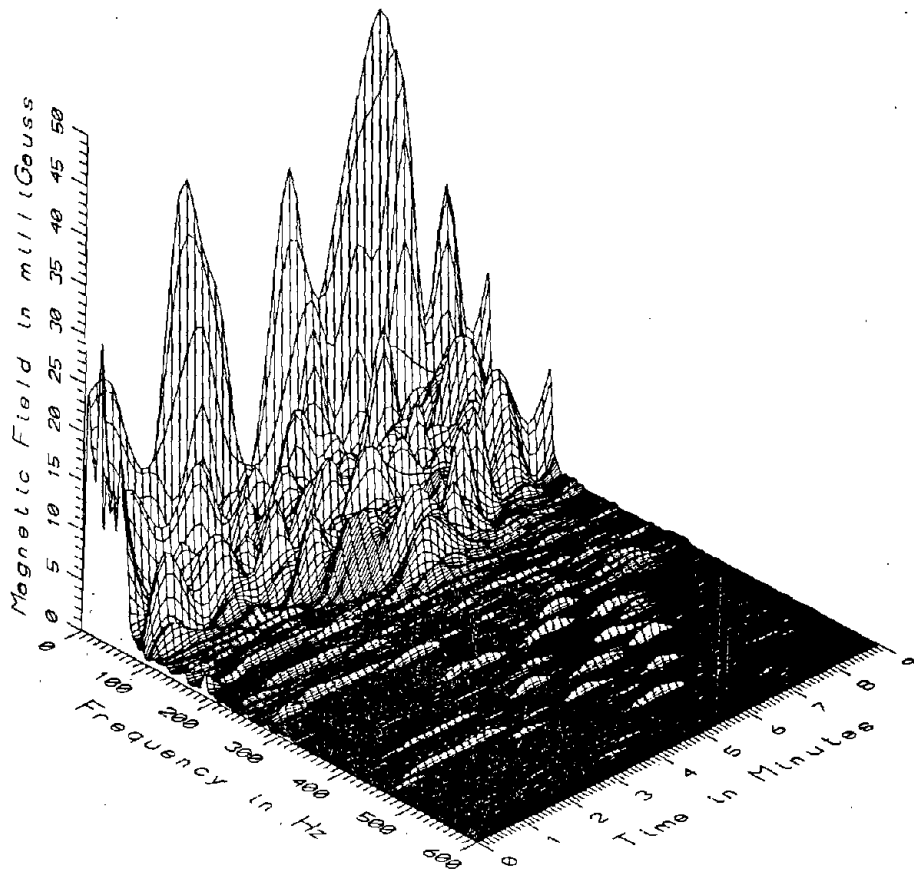

TR7008 - REFERENCE PROBE - BULKHEAD IN REAR OF PASSENGER SECTION, CAR#2

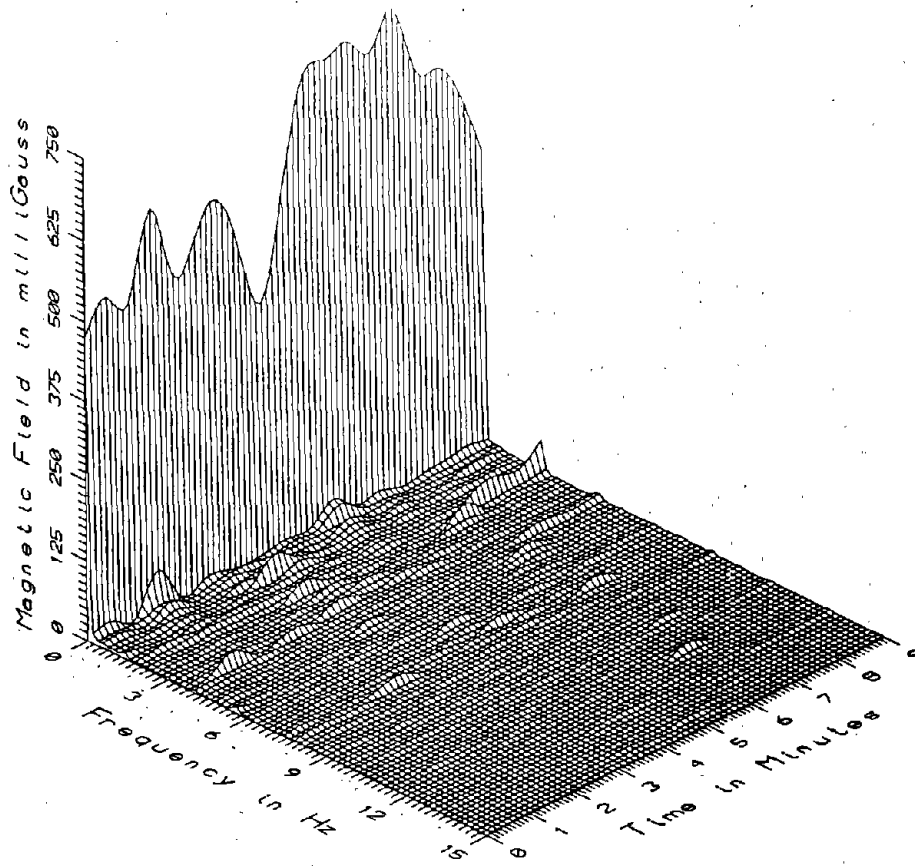

TR7008 - STANDING HEAD LEVEL - WINDOW SEAT AT REAR OF PASSENGER SECTION, CAR#1

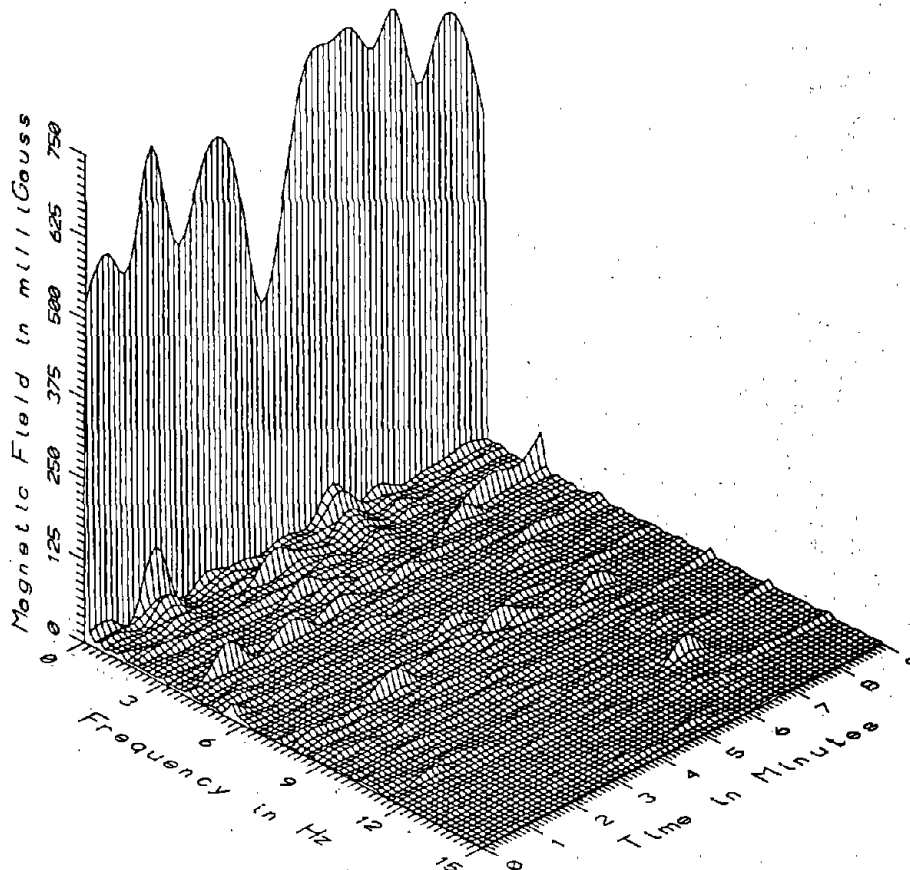

TR7008 - SEATED HEAD LEVEL - WINDOW SEAT AT REAR OF PASSENGER SECTION, CAR#2

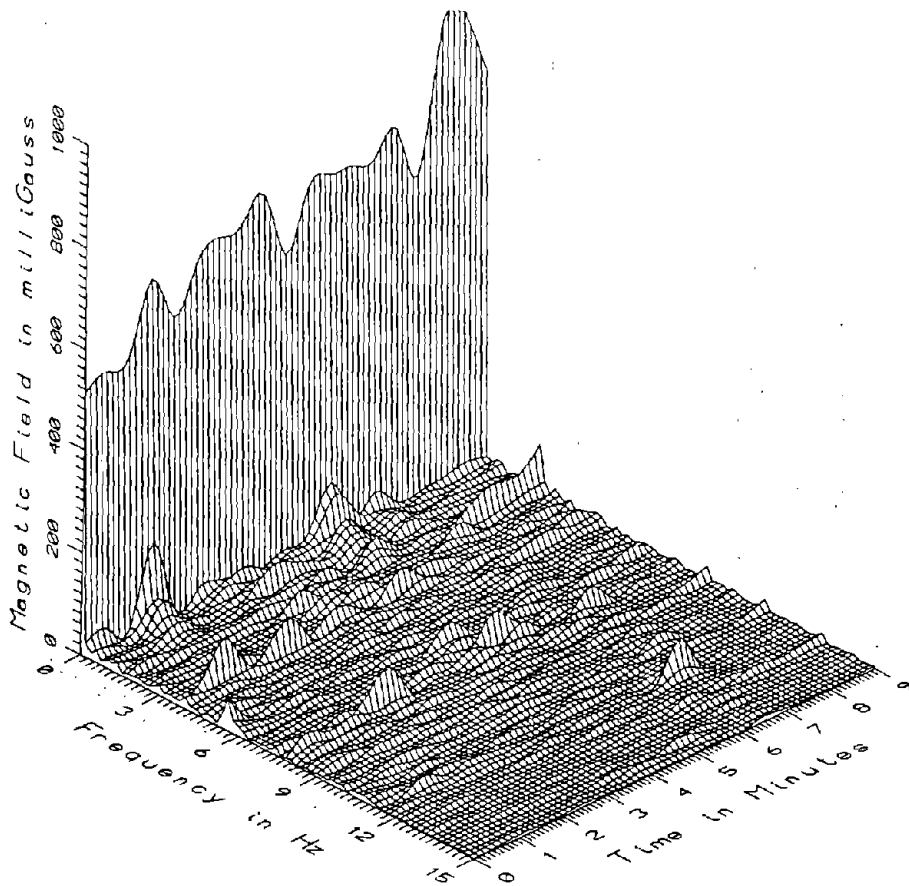

TR7008 - SEAT LEVEL - WINDOW SEAT AT REAR OF PASSENGER SECTION, CAR#2

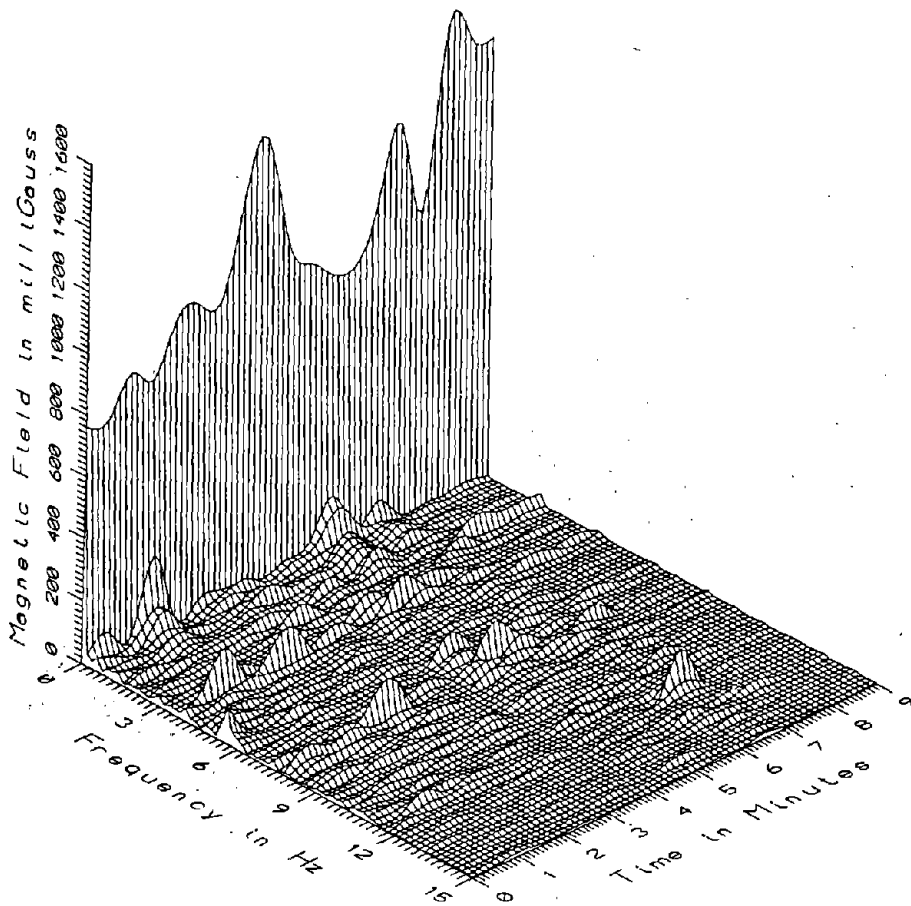

TR7008 - FLOOR LEVEL - WINDOW SEAT AT REAR OF PASSENGER SECTION, CAR#2

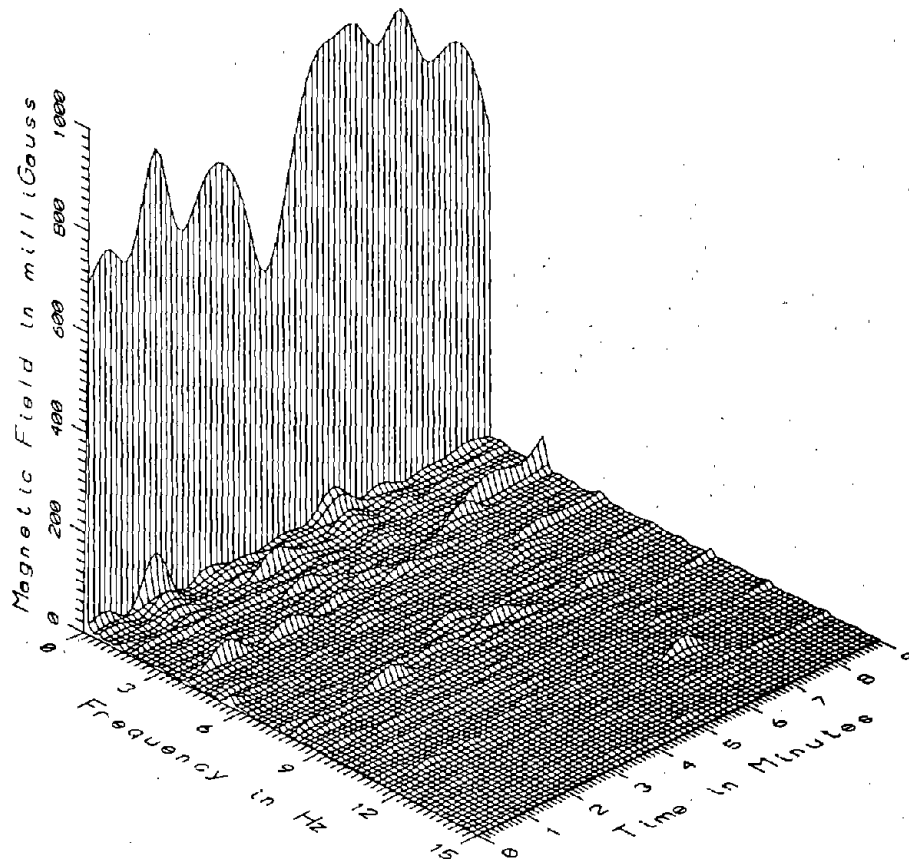

TR700B - REFERENCE PROBE - BULKHEAD AT REAR OF PASSENGER SECTION, CAR#2

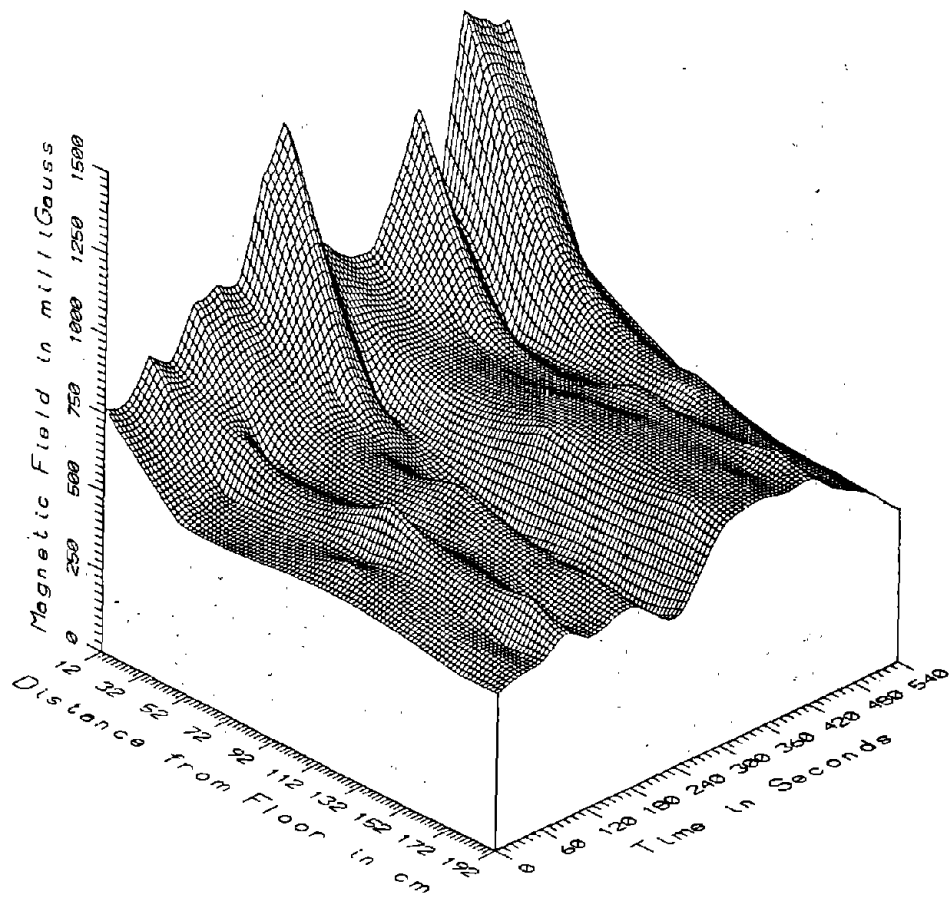

TR700C - WINDOW SEAT IN REAR OF PASSENGER SECTION, CAR2 - DC

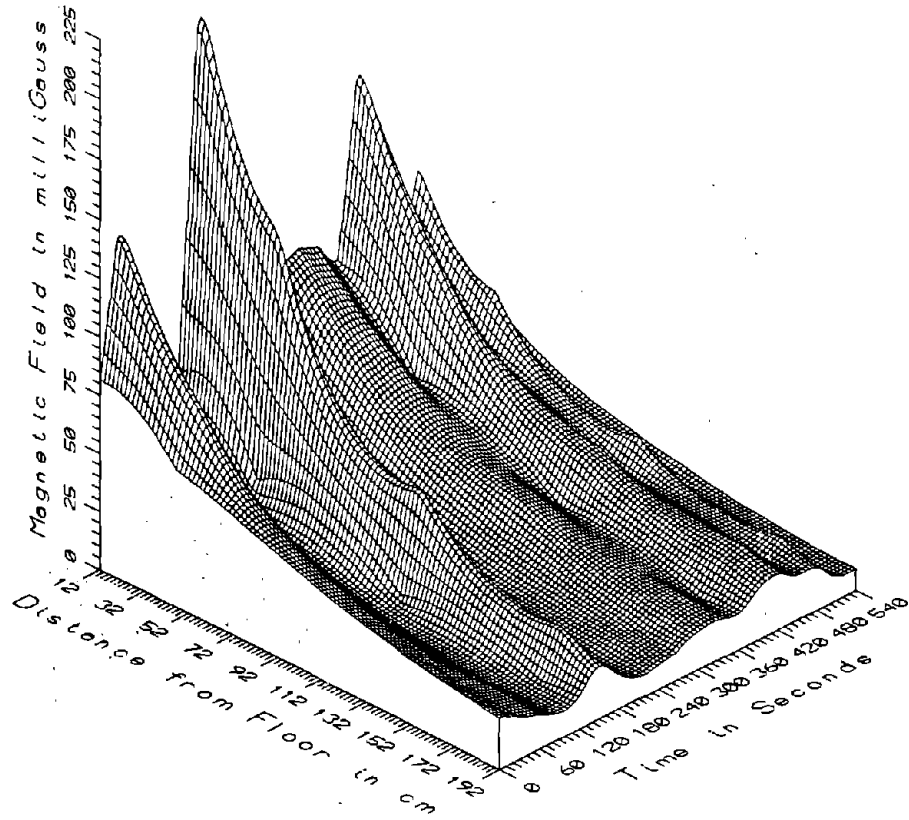

TR7008, WINDOW SEAT IN REAR OF PASSENGER SECTION, CAR2 - LOW FREQ. 5-45Hz

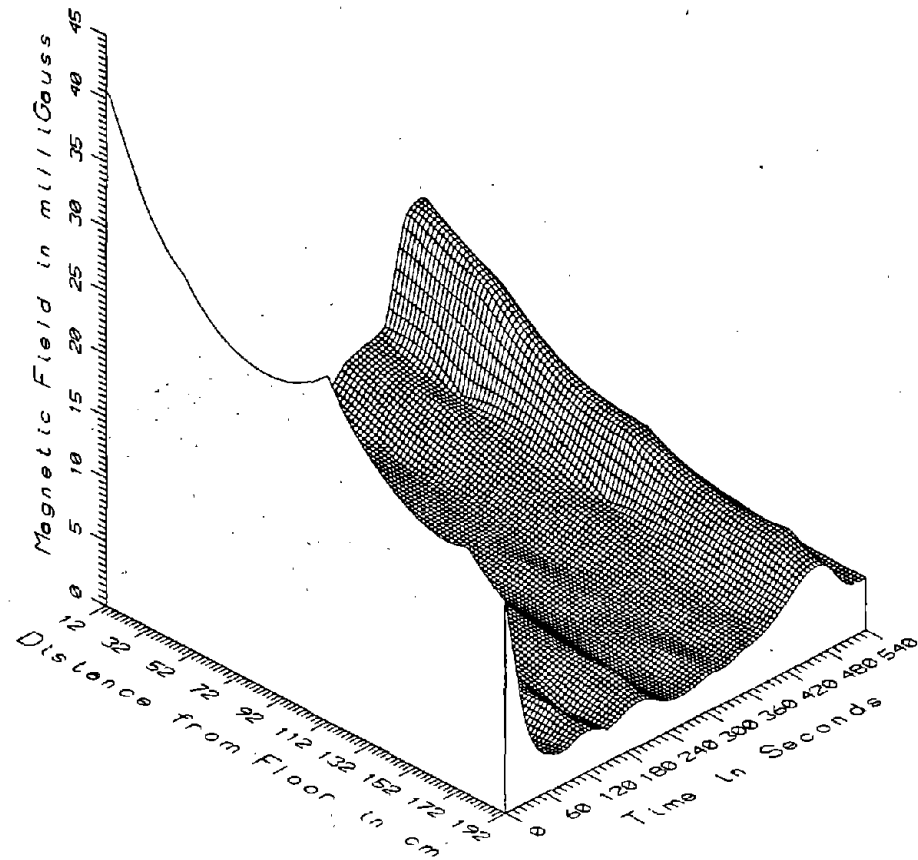

TR7008, WINDOW SEAT IN REAR OF PASSENGER SECTION, CAR2 - POWER FREQ. 50-60Hz

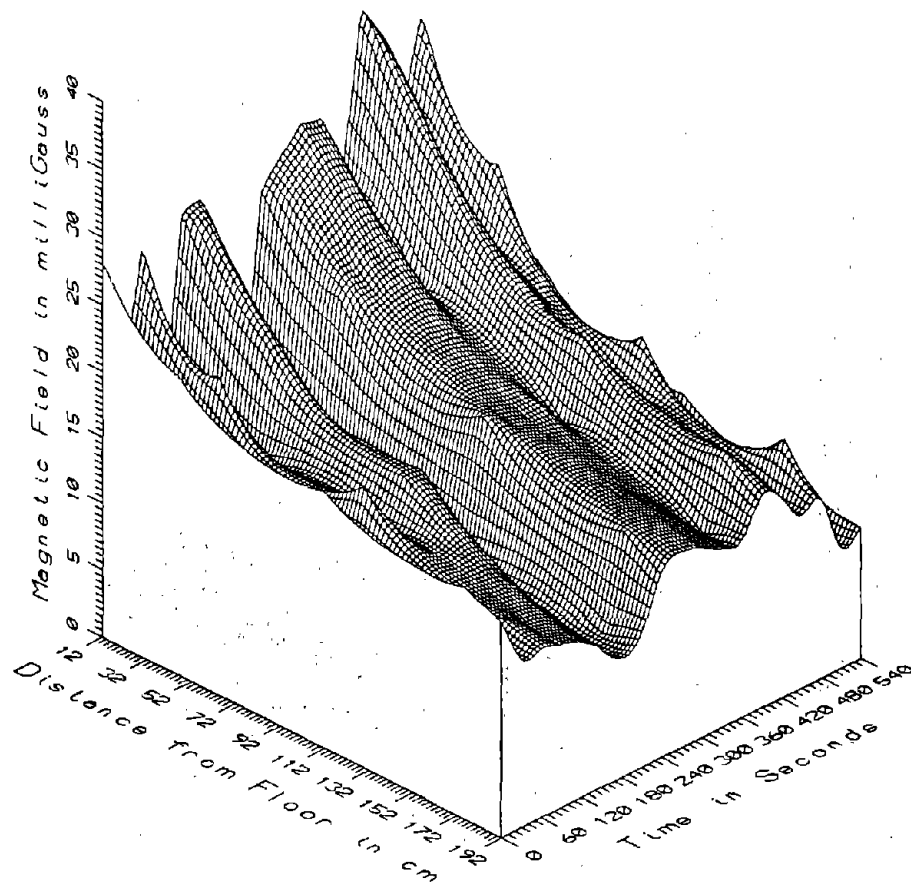

TR700B, WINDOW SEAT IN REAR OF PASSENGER SECTION, CAR2 - POWER HARM, 65-300Hz

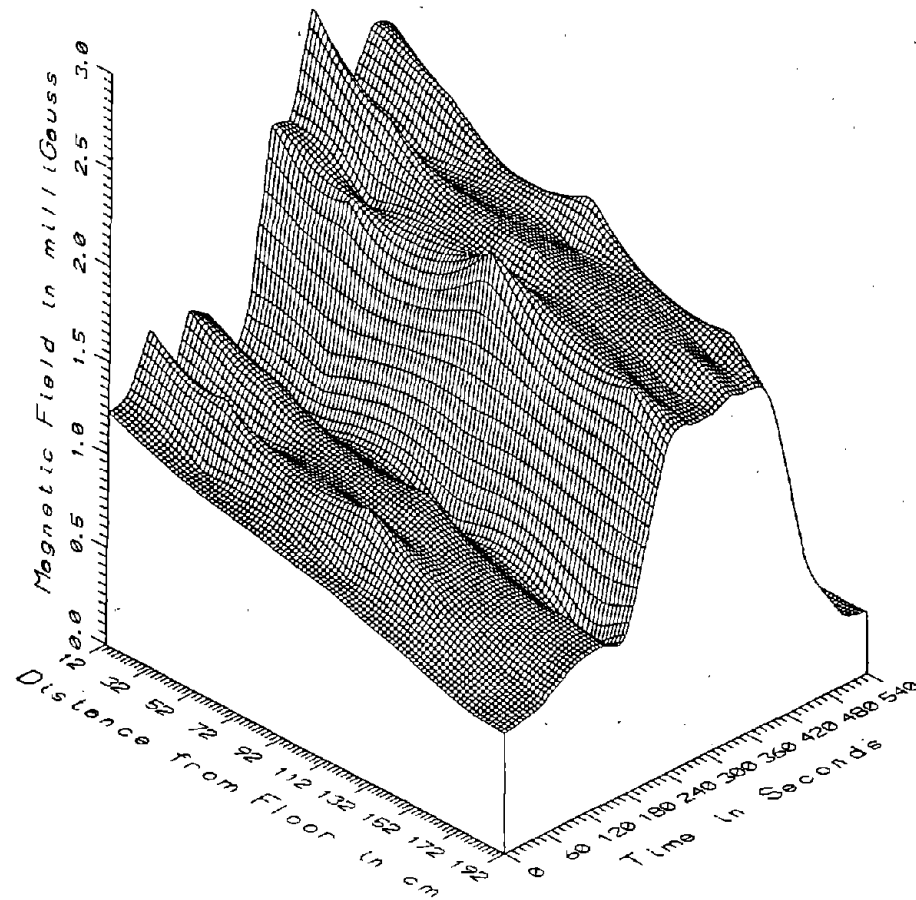

TR700B, WINDOW SEAT IN REAR OF PASSENGER SECTION, CAR2 - HIGH FREQ., 305-2560Hz

E-11

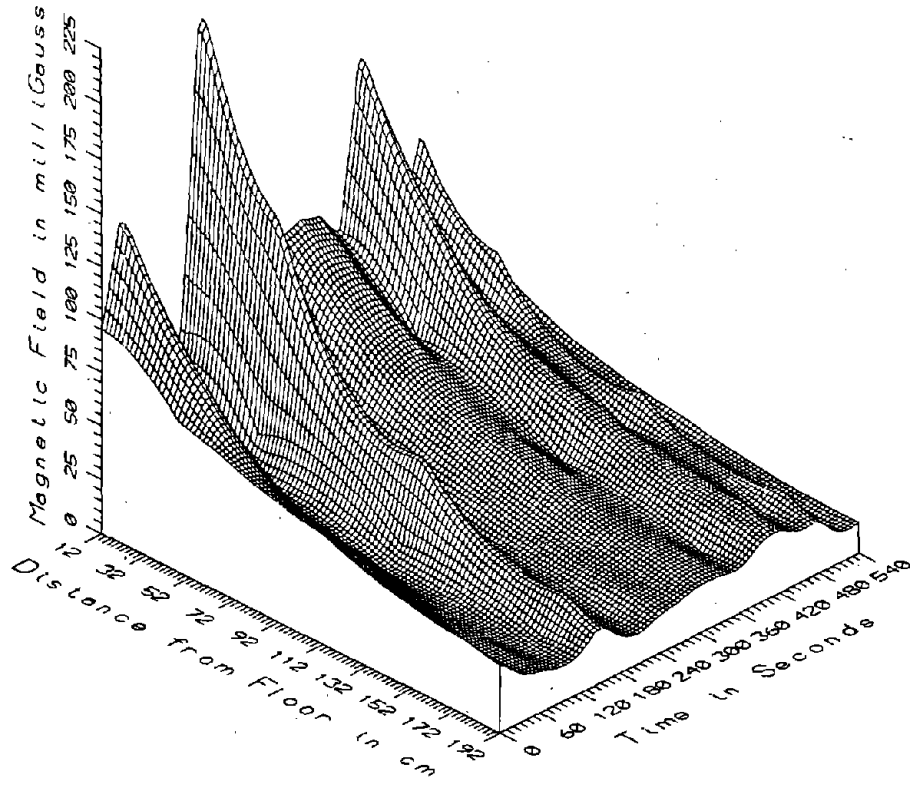

TR7008, WINDOW SEAT IN REAR OF PASSENGER SECTION, CAR2 - ALL FREQ. 5-2560Hz

F-1

APPENDIX F

DATA SET TR7009

**VIP PASSENGER SECTION,
AT SEAT, REAR CAR**

APPENDIX F

DATA SET TR7009
VIP PASSENGER SECTION, AT SEAT, REAR CAR

Measurement Setup Code: 14 (coil-type) & 13 (fluxgate-type)
 Vehicle Status: Running continuously
 Measurement Date: August 7, 1990
 Measurement Time: Start: 17:50:00
 End: 18:00:00
 Number of Samples: 17
 Programmed Sample Interval: 30 sec
 Actual Sample Interval: 35 sec

Frequency Spectrum Parameters

<u>Probe Type:</u>	<u>Coil (AC)</u>	<u>Fluxgate (DC)</u>
Maximum Frequency (Hz)	2560	102.4
Minimum Frequency (Hz)	5	0
Spectral Bandwidth (Hz)	5	0.2

Missing or Suspect Data: The floor level fluxgate sensor saturated on the vertical axis for all 17 samples. The seat level and seated head level fluxgate sensors saturated on the vertical axis for 2 and 4 of the 17 locations, respectively.

ON-VEHICLE MEASUREMENT POINTS (AUG. 7, '90)

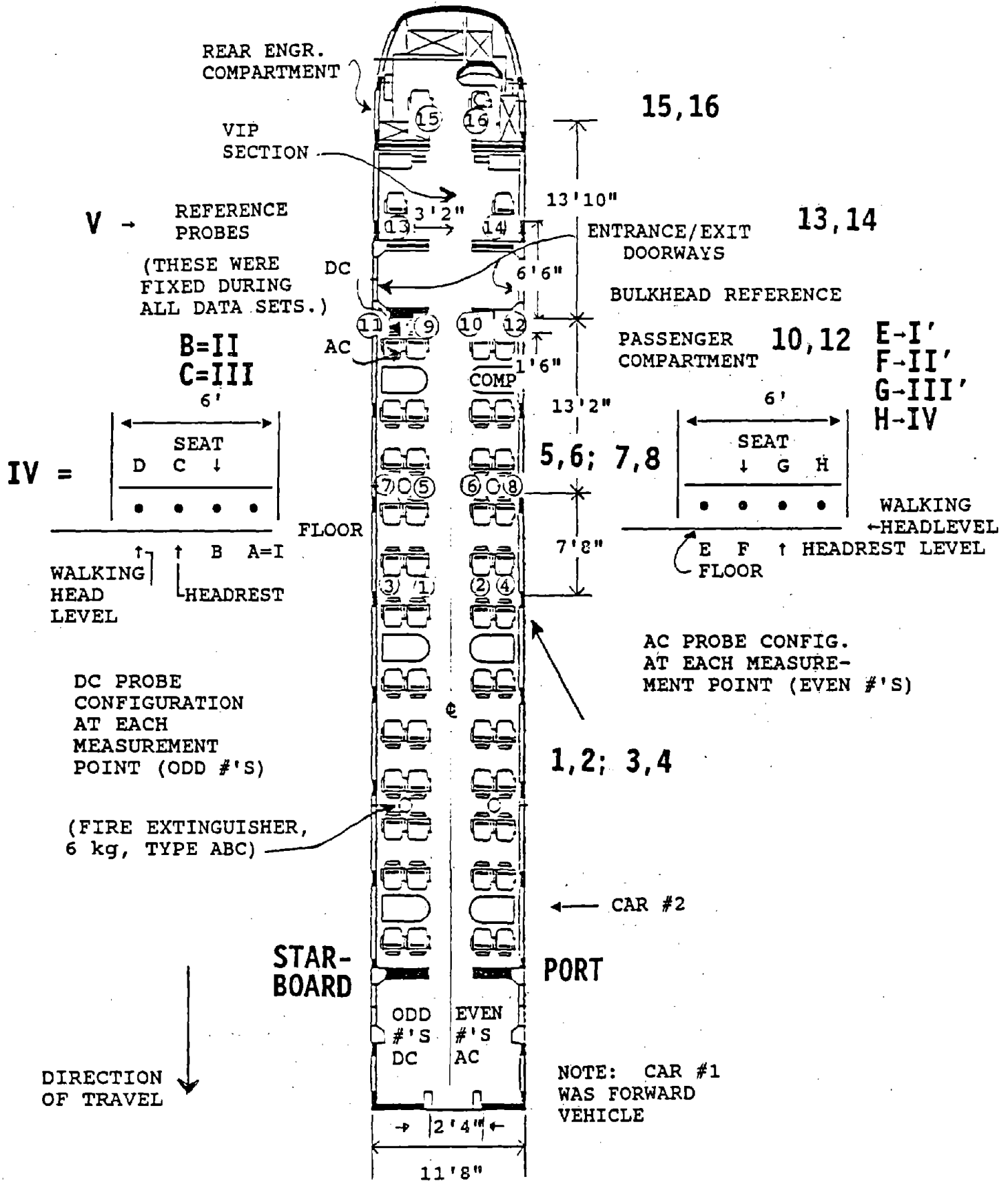

VEHICLE SPEED - TR7009

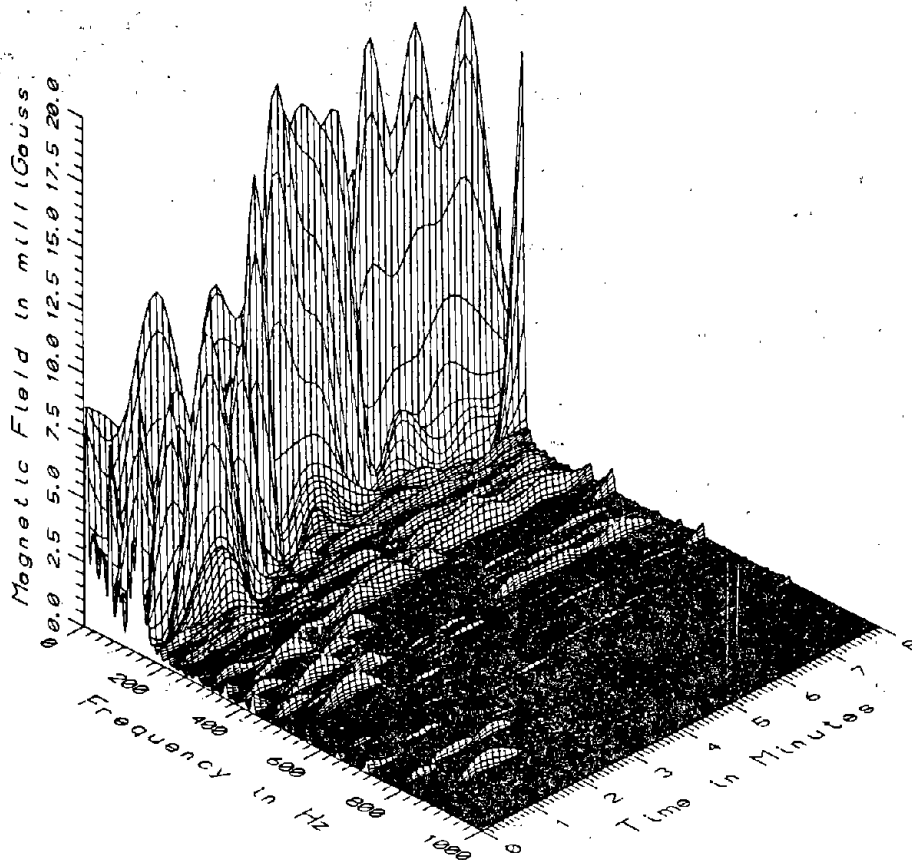
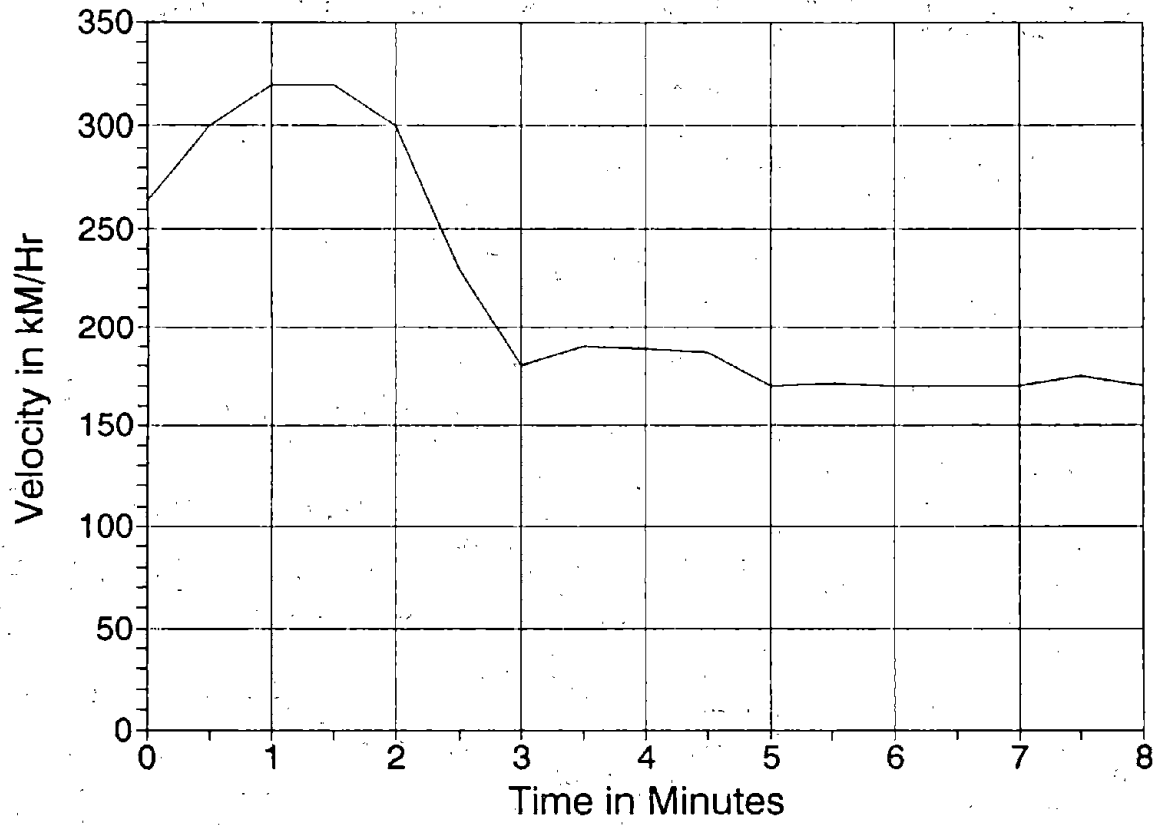

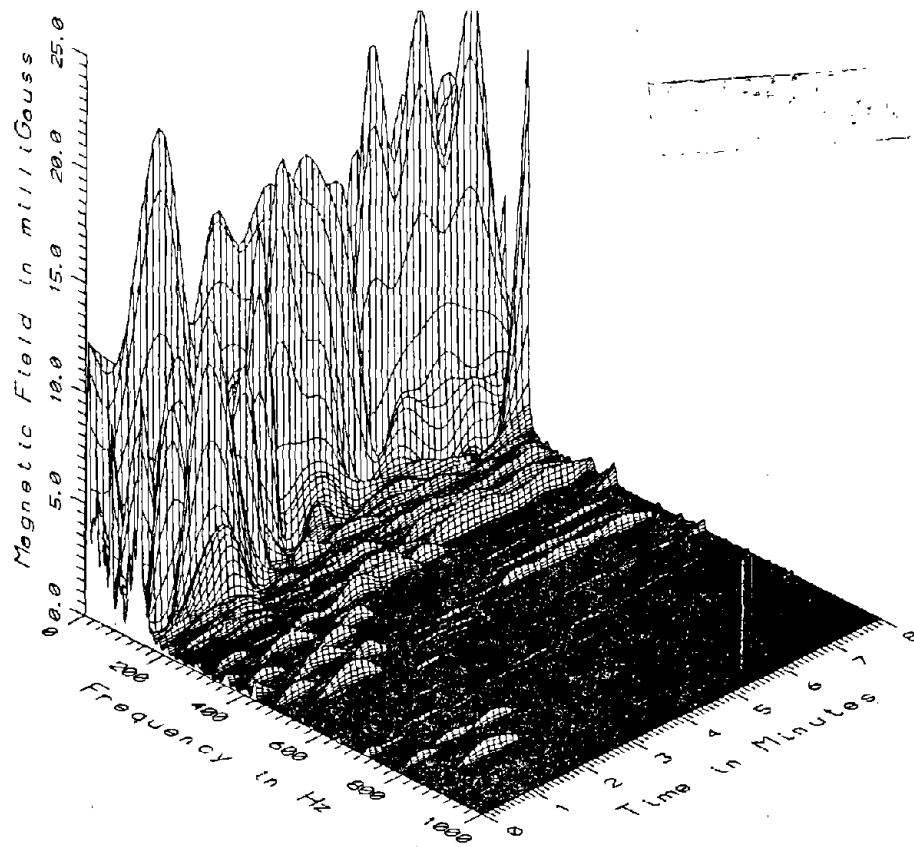

TR7009 - SEATED HEAD LEVEL - V.I.P. SECTION, CAR#2

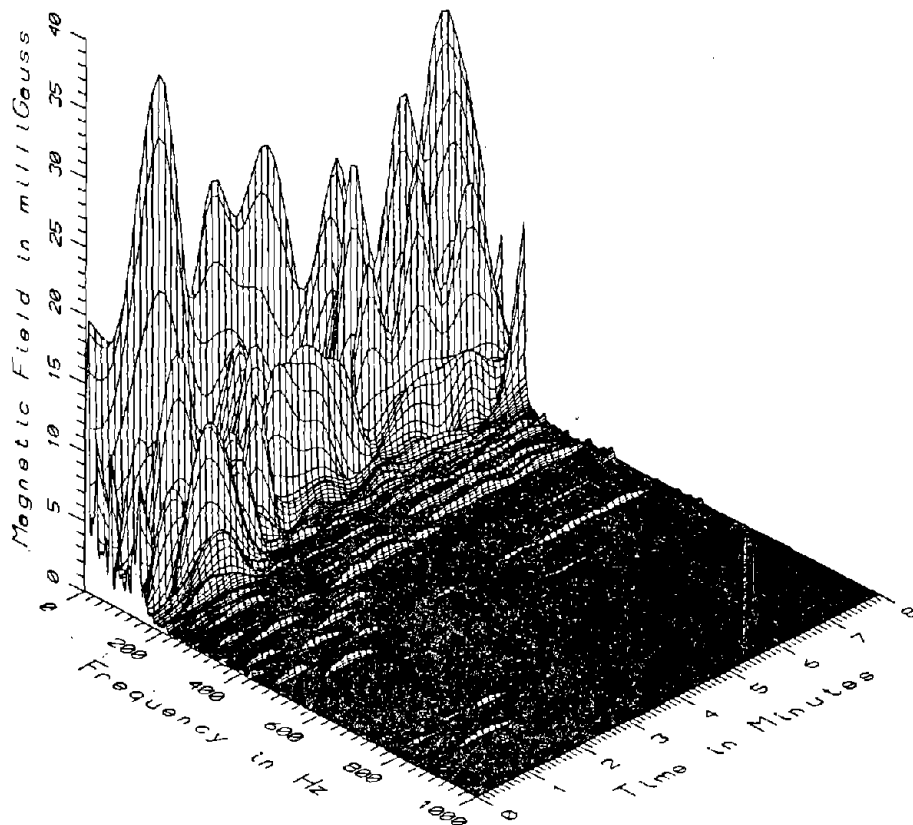

TR7009 - SEAT LEVEL - V.I.P. SECTION, CAR#2

F-5

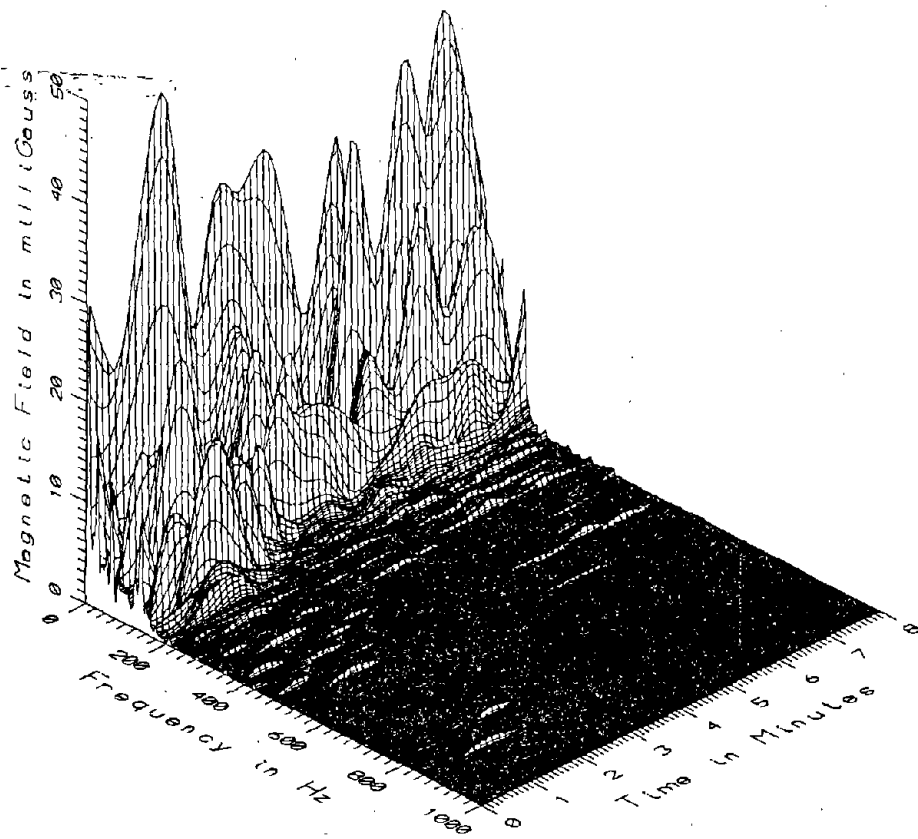

TR7009 - FLOOR LEVEL - V.I.P. SECTION, CAR#2

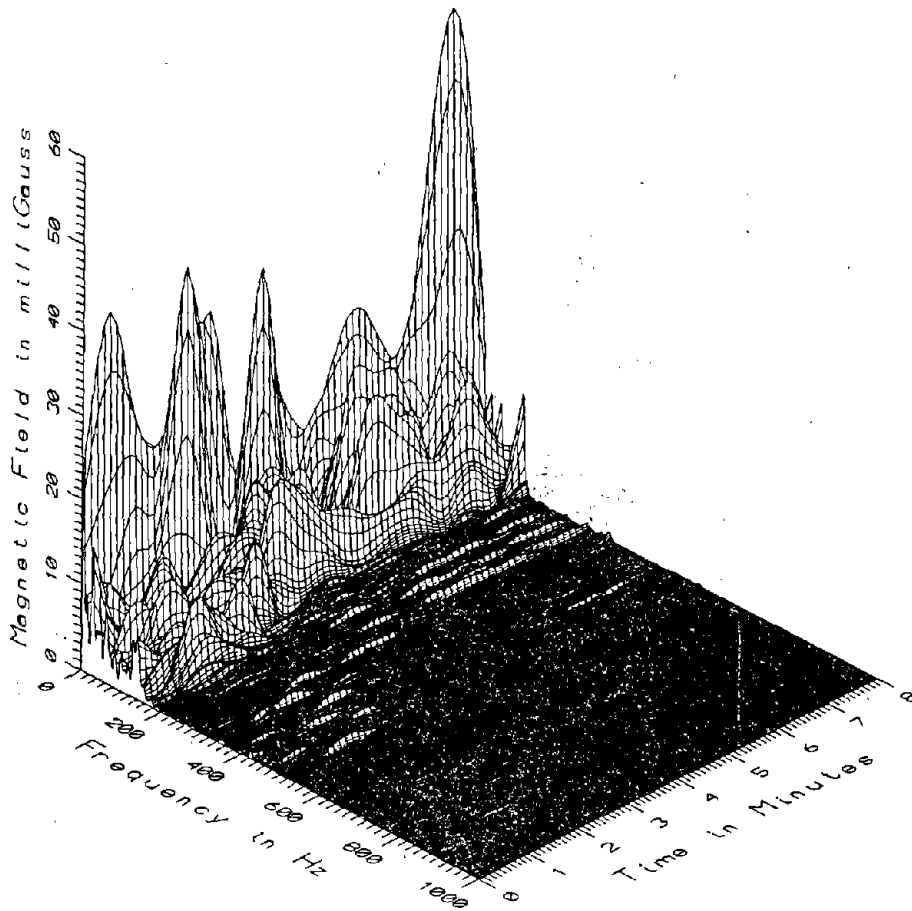

TR7009 - REFERENCE PROBE - BULKHEAD IN REAR OF PASSENGER SECTION, CAR#2

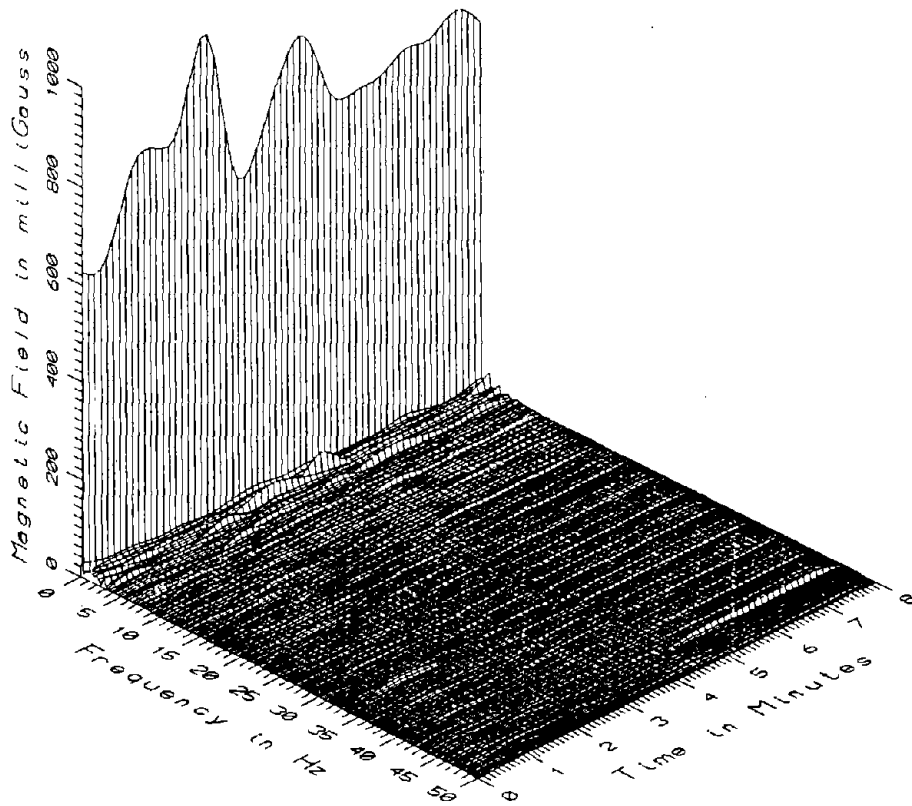

TR7009 - STANDING HEAD LEVEL - VIP SECTION, CAR#2

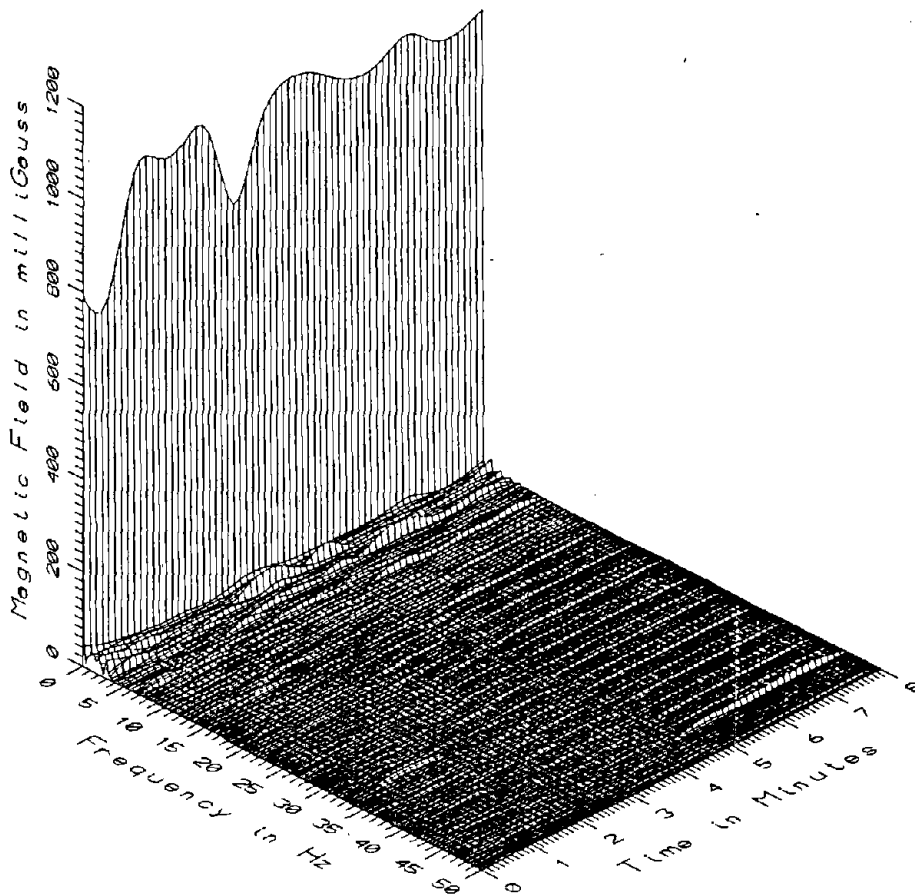

TR7009 - SEATED HEAD LEVEL - VIP SECTION, CAR#2

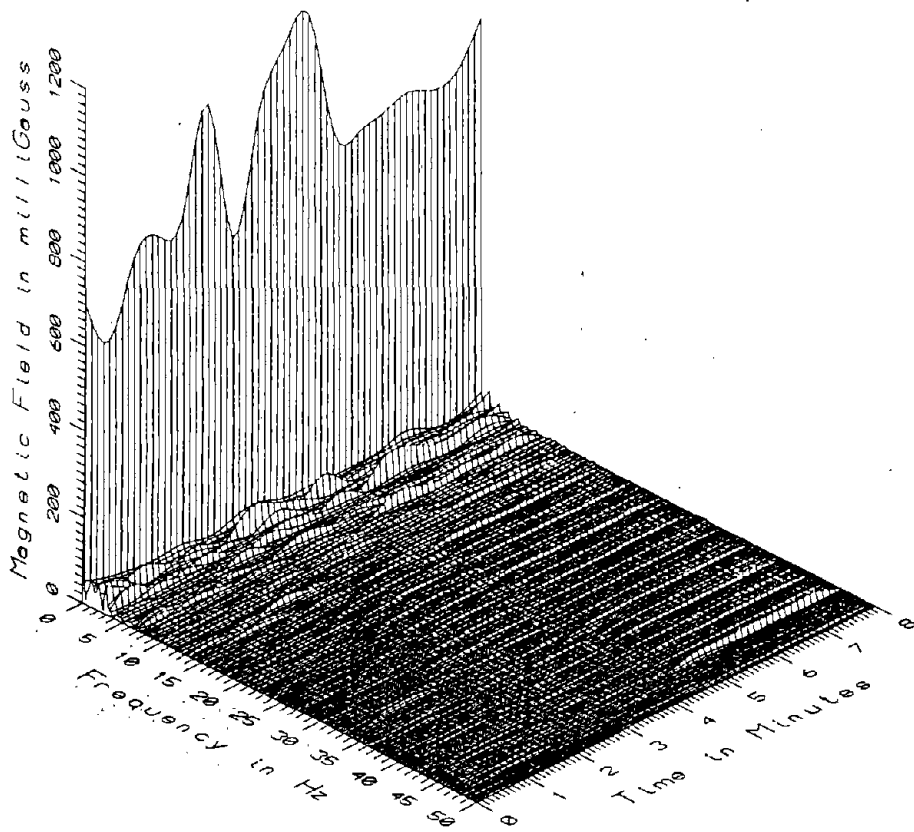

TR7009 - SEAT LEVEL - VIP SECTION, CAR#2

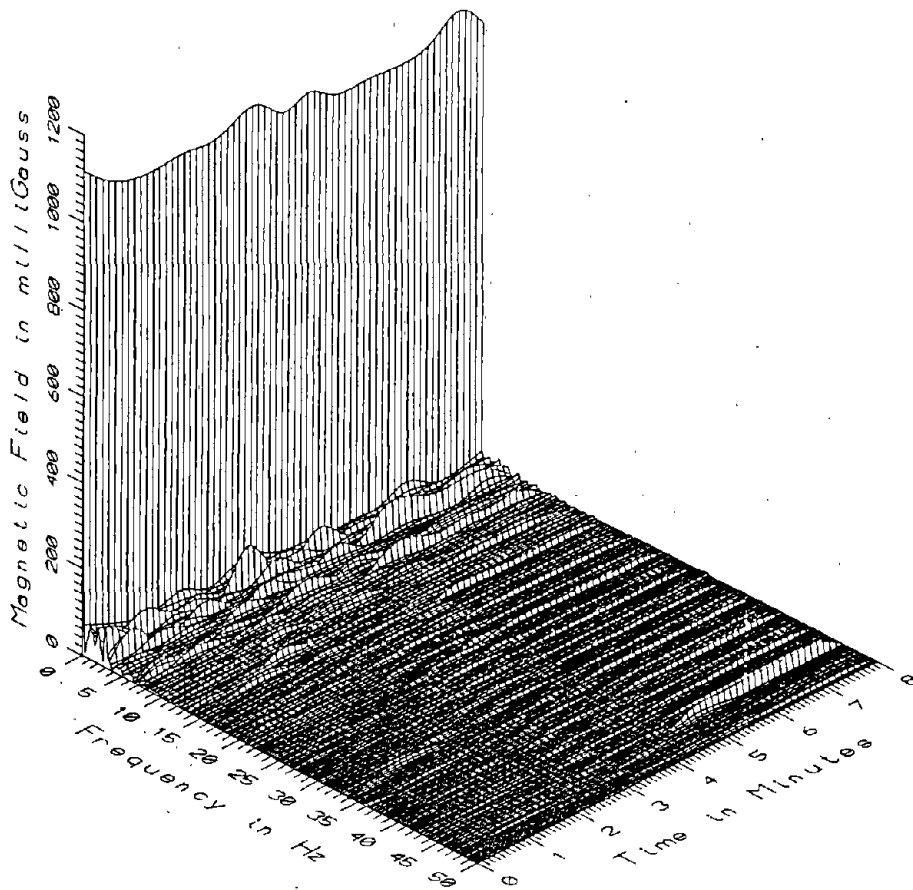

TR7009 - FLOOR LEVEL - VIP SECTION, CAR#2

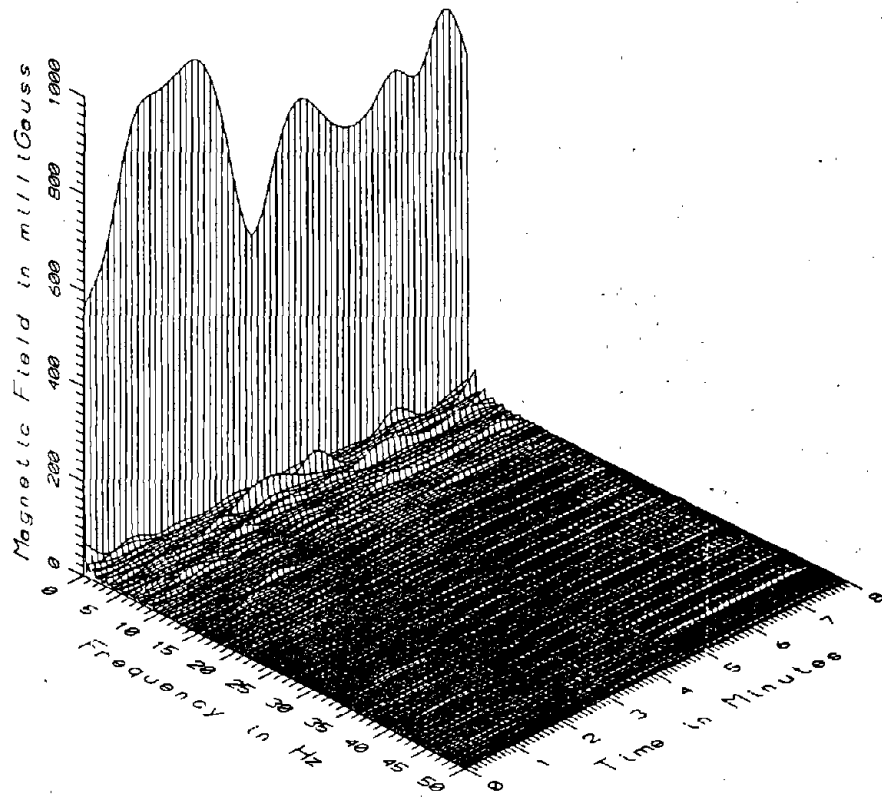

TR7009 - REFERENCE PROBE - BULKHEAD AT REAR OF PASSENGER SECTION, CAR#2

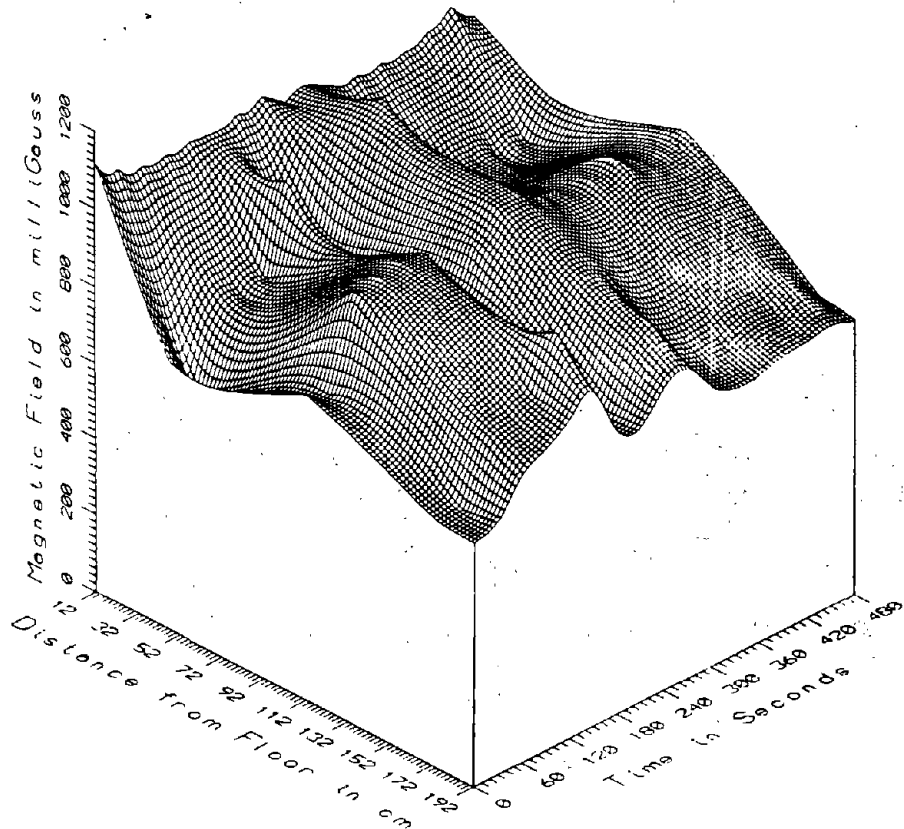

TR7009 - VIP SECTION, CAR#2 - DC

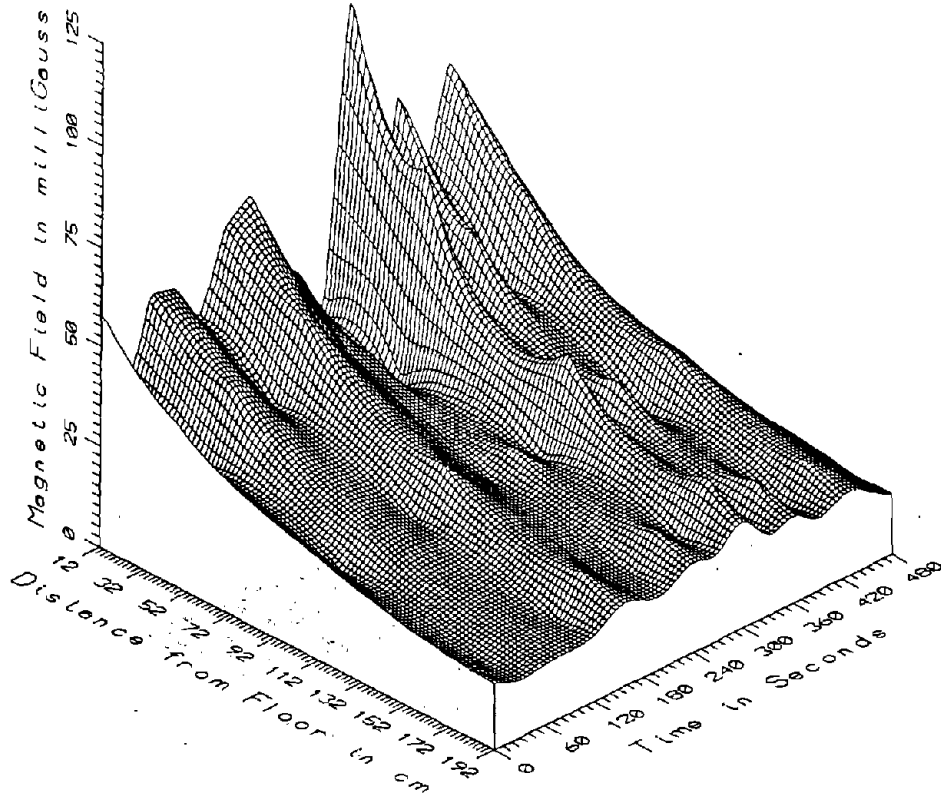

TR7009, VIP SECTION, CAR#2 - LOW FREQUENCY 5-45Hz

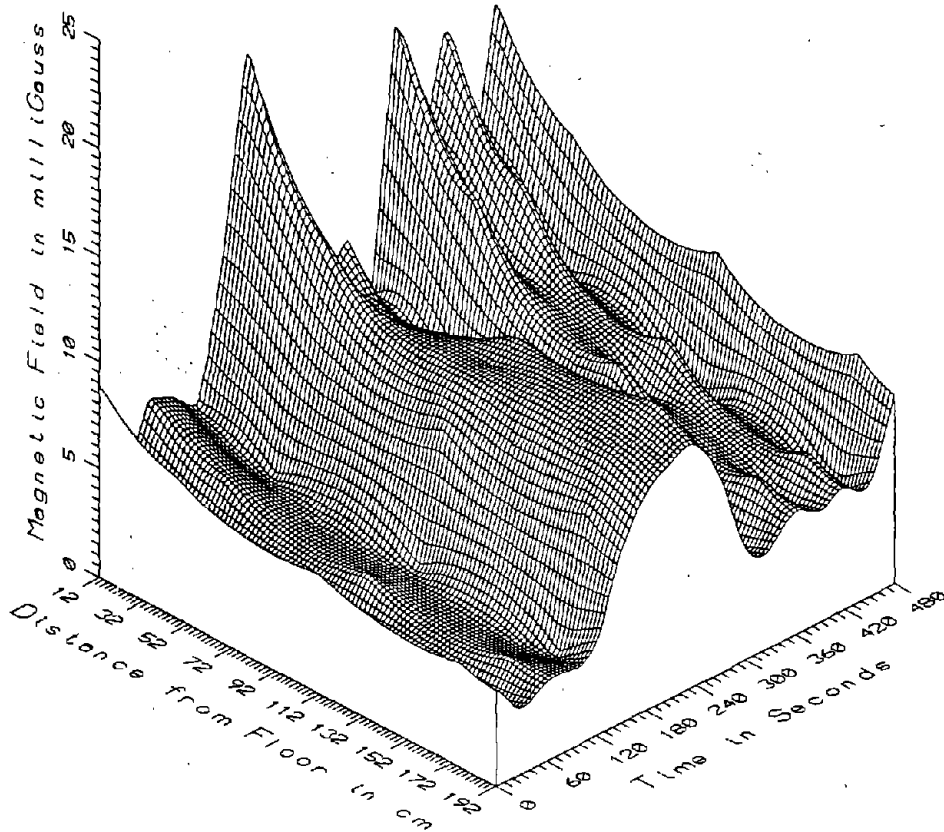

TR7009, VIP SECTION, CAR#2 - POWER FREQUENCY 50-60Hz

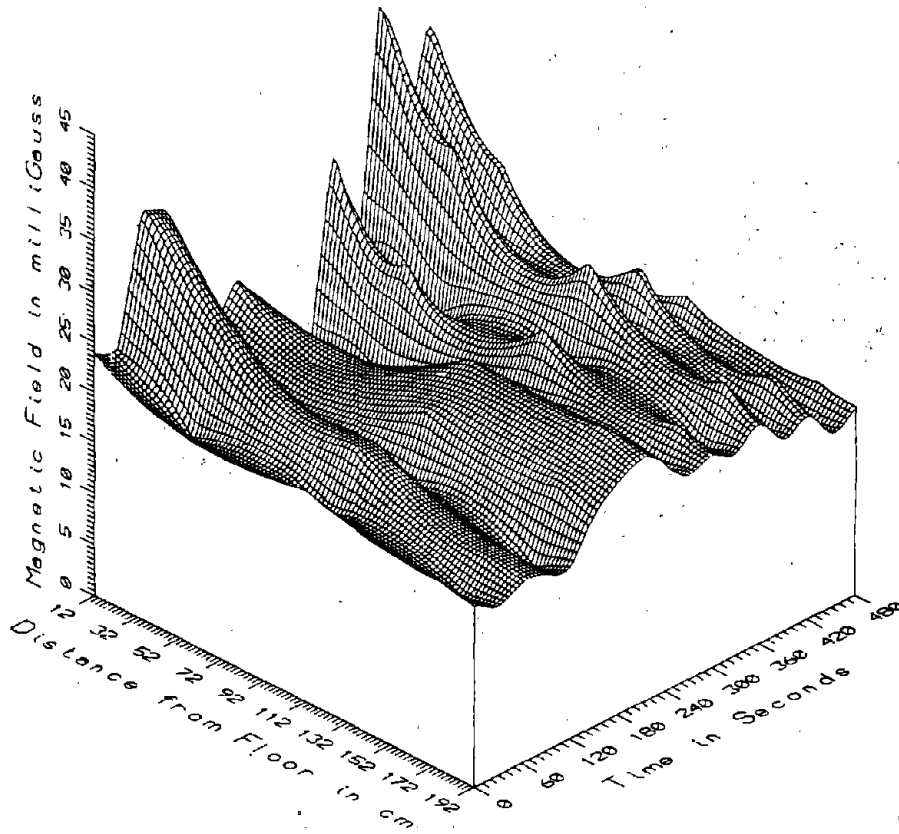

TR7009, VIP SECTION, CAR#2 - POWER HARMONICS 65-300Hz

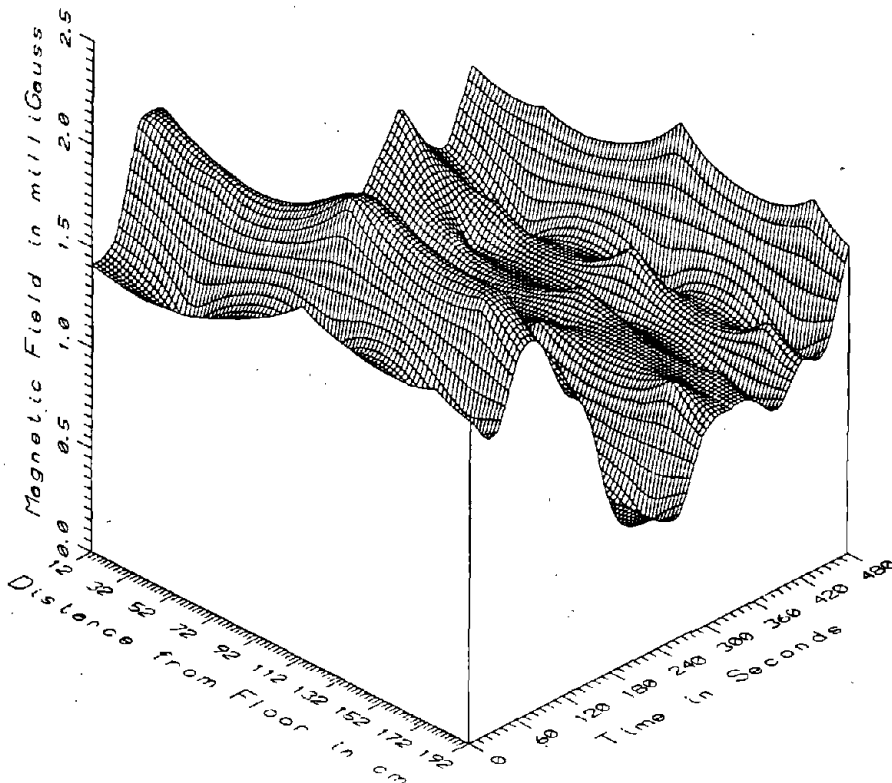

TR7009, VIP SECTION, CAR#2 - HIGH FREQUENCY 305-2560Hz

F-12

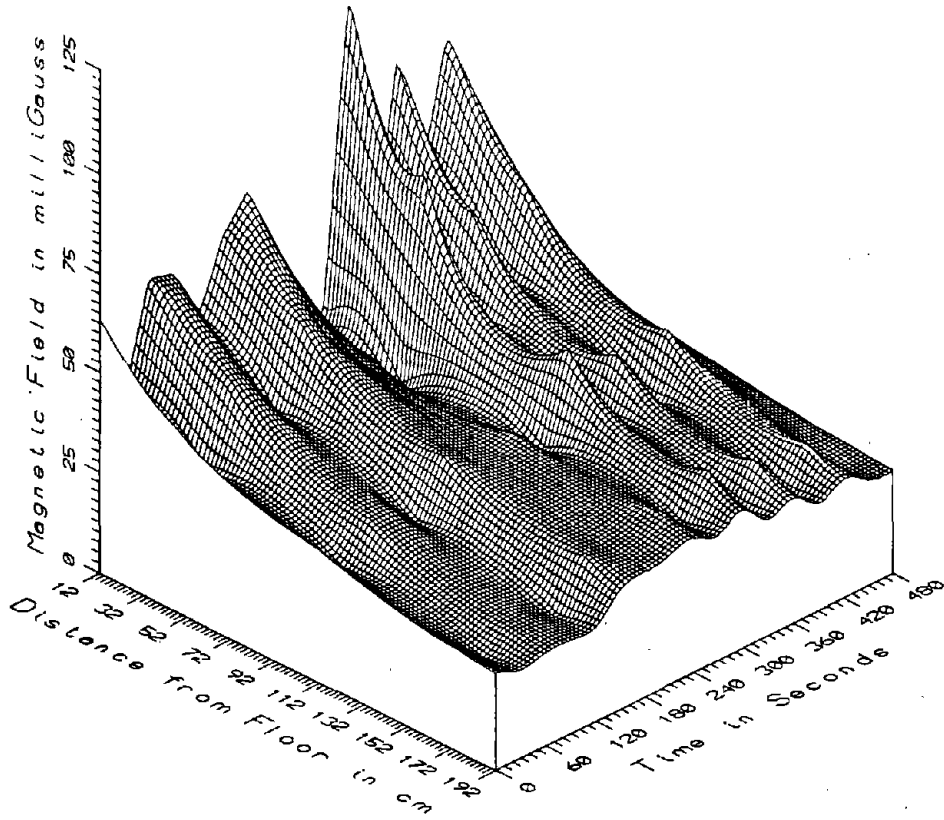

TR7009, VIP SECTION, CAR#2 - ALL FREQUENCIES 5-2560Hz

APPENDIX G

DATA SET TR7010

**VEHICLE ENGINEER'S COMPARTMENT,
AT SEAT, REAR CAR**

G-2

APPENDIX G

DATA SET TR7010
VEHICLE ENGINEER'S COMPARTMENT, AT SEAT, REAR CAR

Measurement Setup Code: 16 (coil-type) & 15 (fluxgate-type)
Vehicle Status: Running continuously
Measurement Date: August 7, 1990
Measurement Time: Start: 18:02:00
End: 18:12:00
Number of Samples: 20
Programmed Sample Interval: 30 sec
Actual Sample Interval: 31 sec

Frequency Spectrum Parameters

<u>Probe Type:</u>	<u>Coil (AC)</u>	<u>Fluxgate (DC)</u>
Maximum Frequency (Hz)	2560	102.4
Minimum Frequency (Hz)	5	0
Spectral Bandwidth (Hz)	5	0.2

Missing or Suspect Data: The floor level fluxgate sensor saturated on the vertical axis for 9 of the 20 samples. The seat level fluxgate sensor saturated on the vertical axis for 5 of the 20 samples.

ON-VEHICLE MEASUREMENT POINTS (AUG. 7, '90)

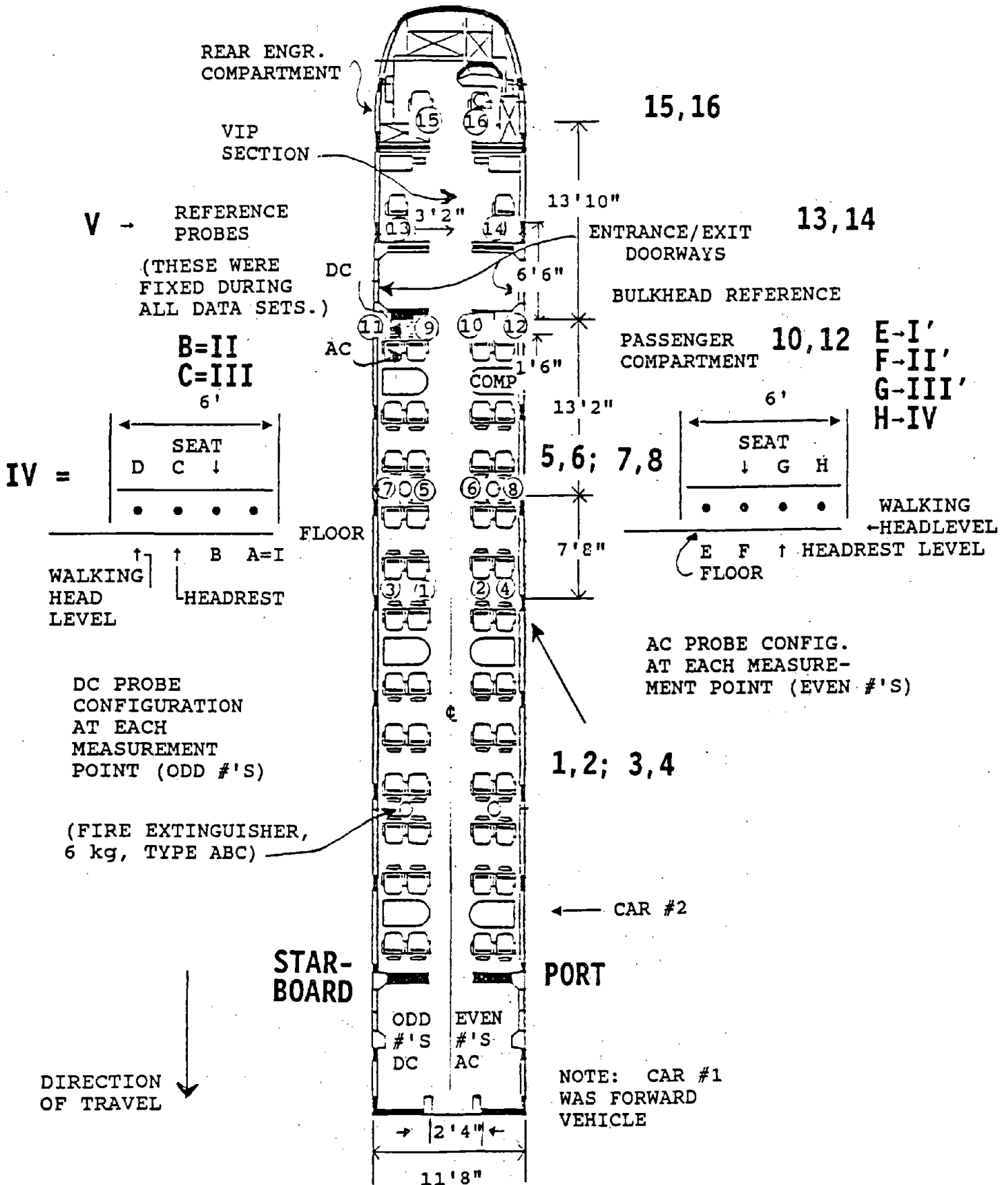

VEHICLE SPEED - TR7010

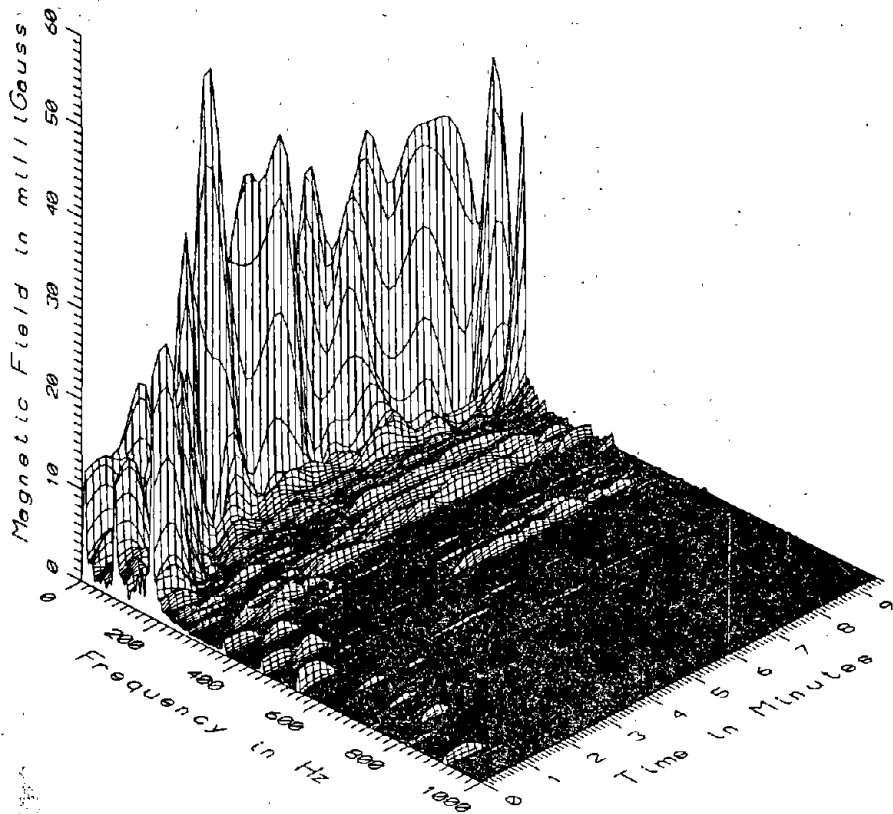
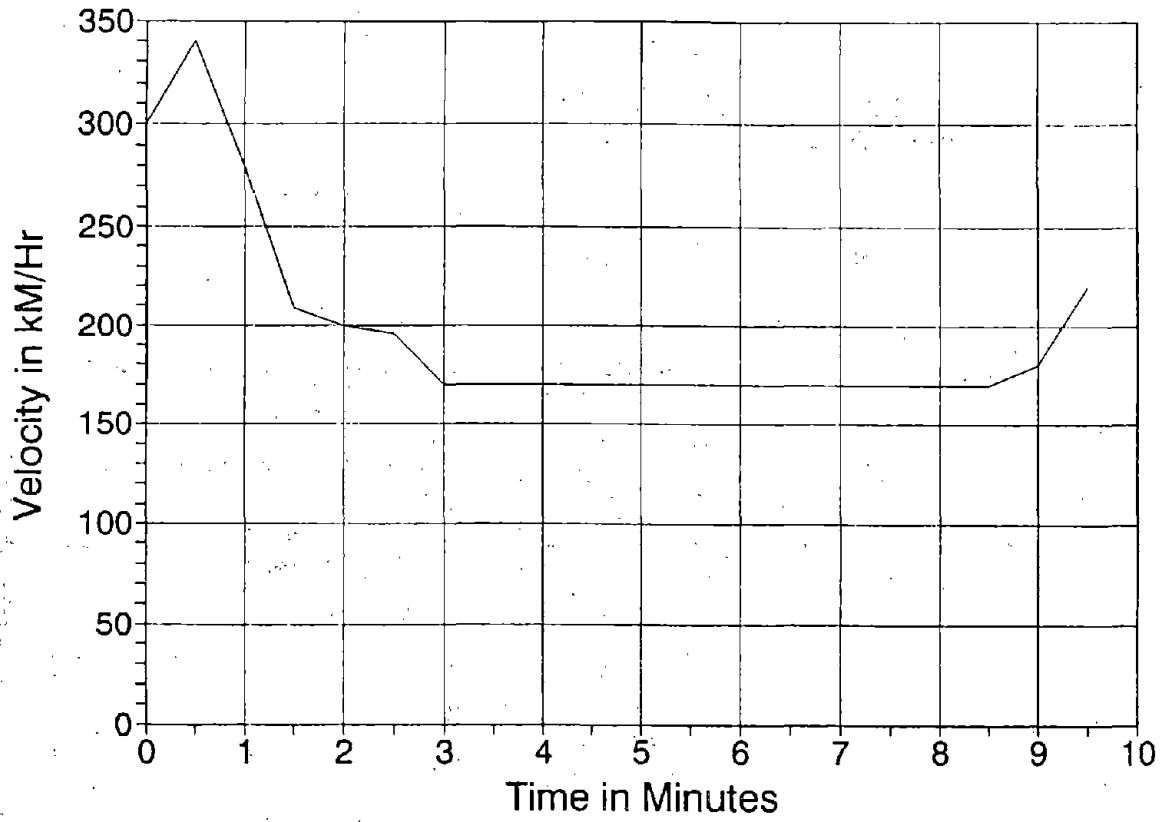

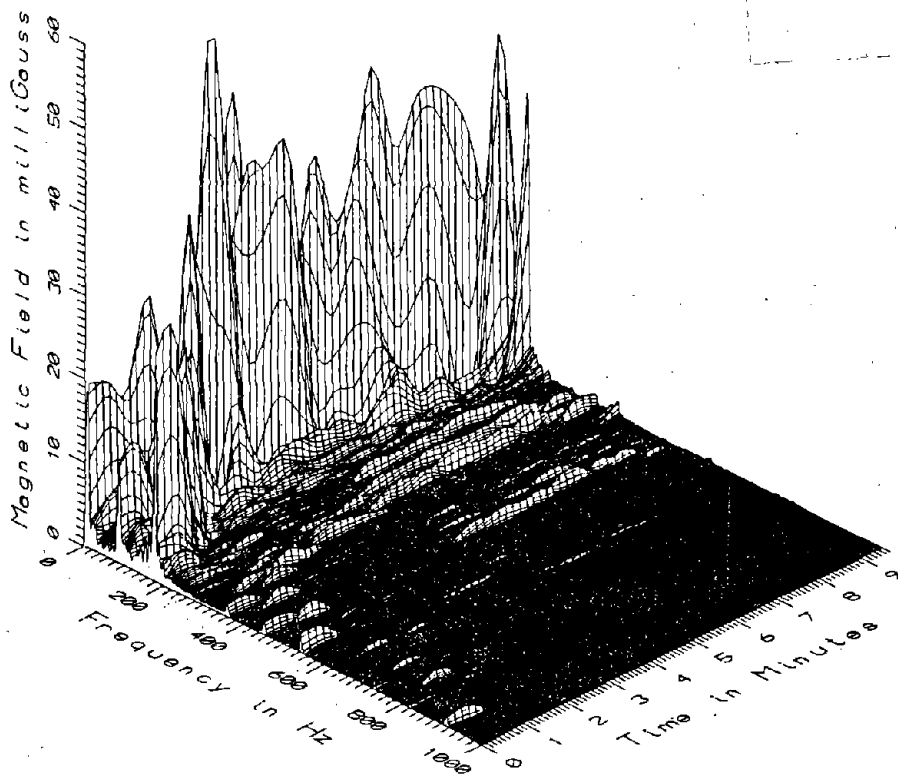

TR7010 - SEATED HEAD LEVEL - REAR ENGINEER SECTION, CAR#2

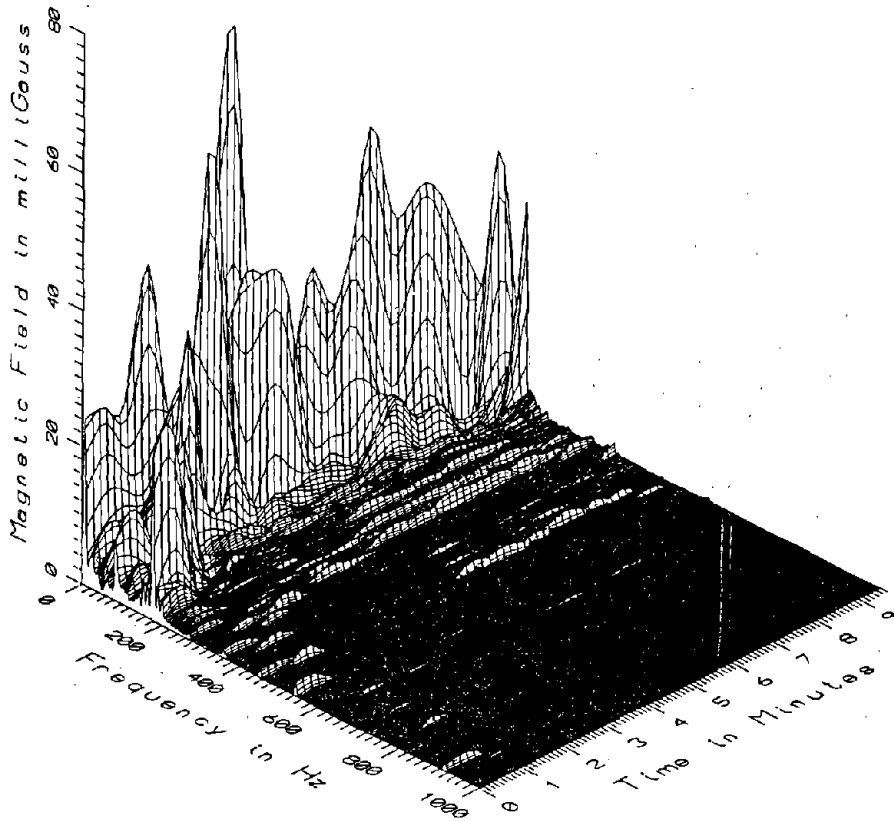

TR7010 - SEAT LEVEL - REAR ENGINEER SECTION, CAR#2

G-5

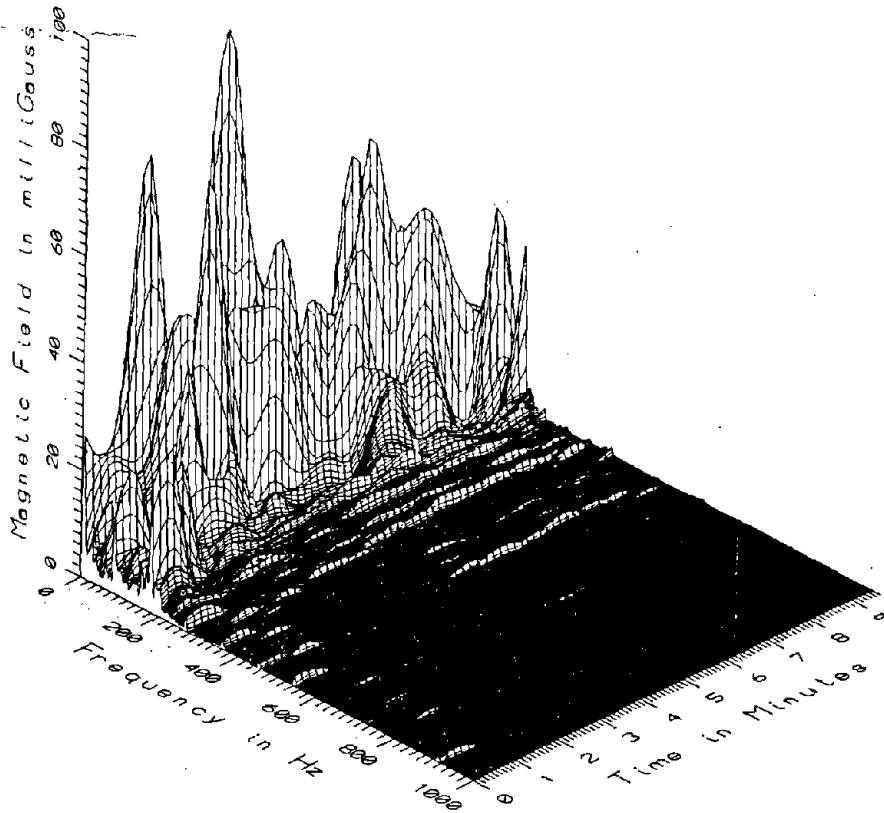

TR7010 - FLOOR LEVEL - REAR ENGINEER SECTION, CAR#2

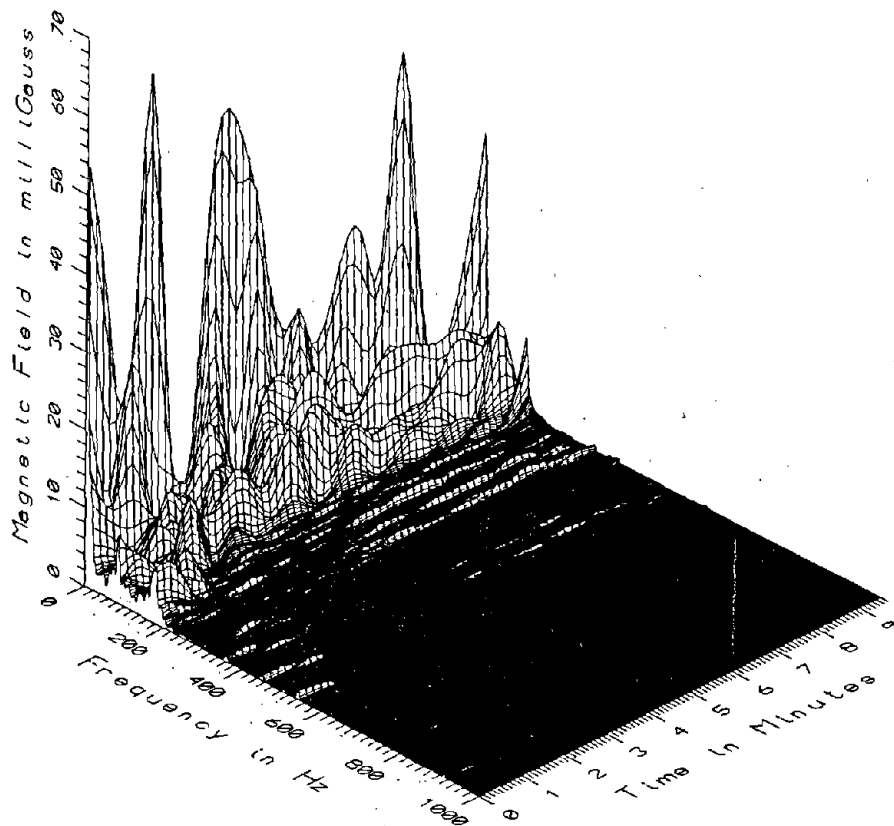

TR7010 - REFERENCE PROBE - BULKHEAD IN REAR OF PASSENGER SECTION, CAR#2

A-6

VEHICLE SPEED - TR7010

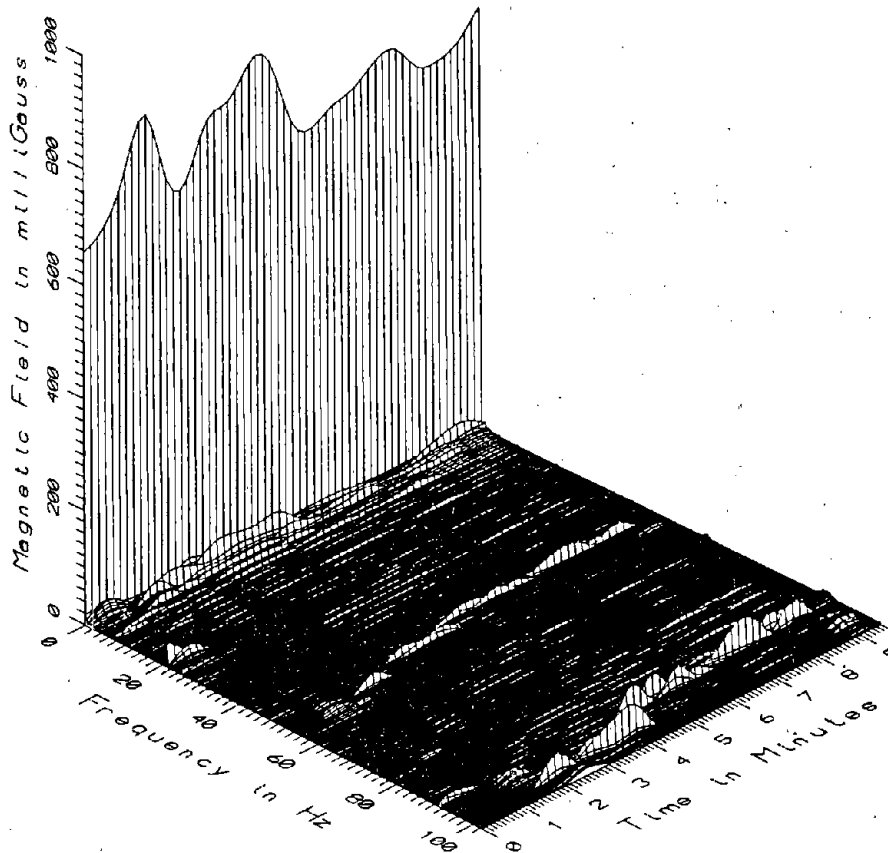
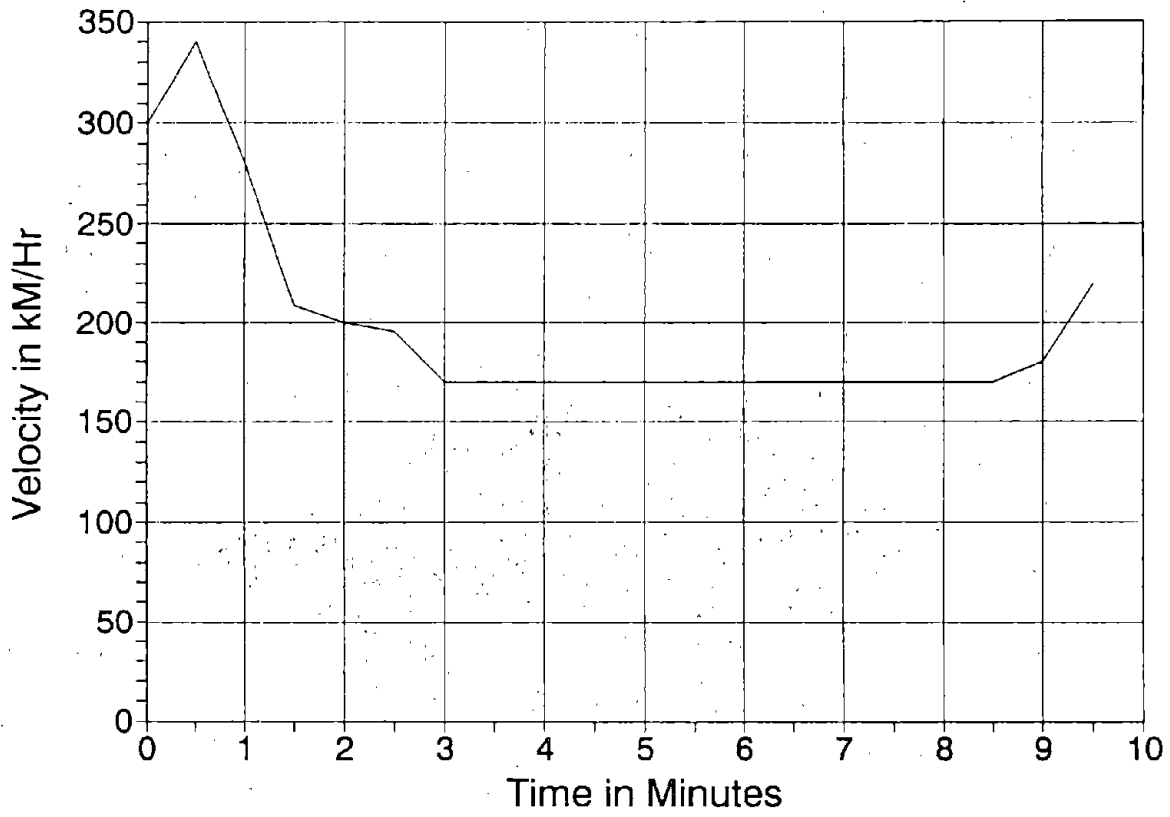

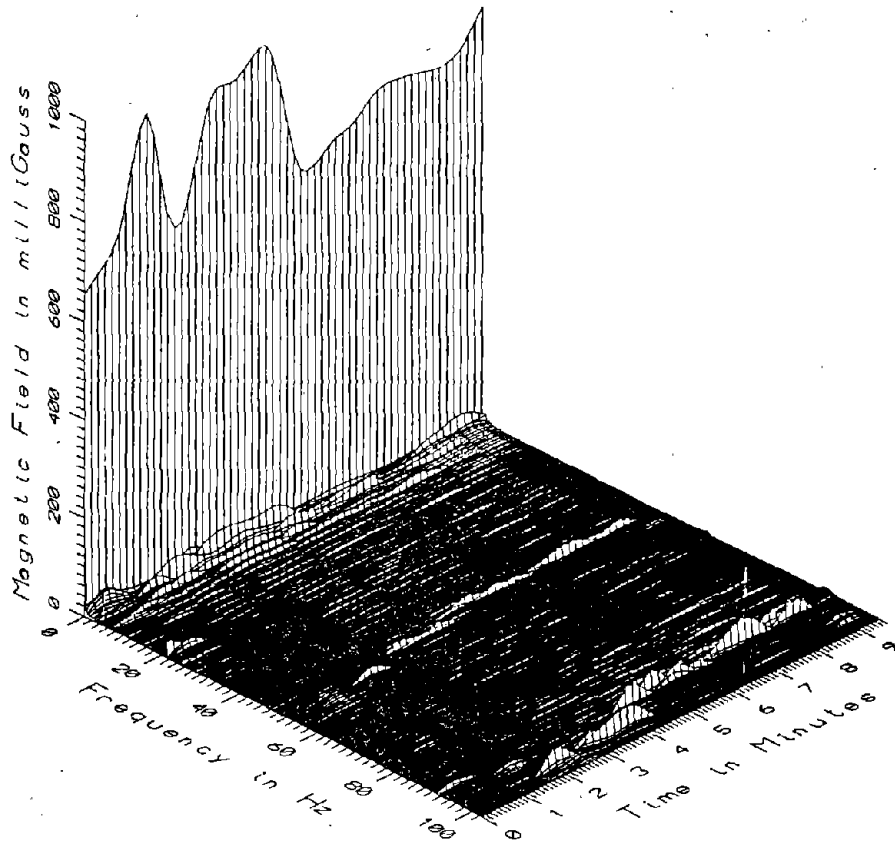

TR7010 - SEATED HEAD LEVEL - REAR ENGINE SECTION, CAR#2

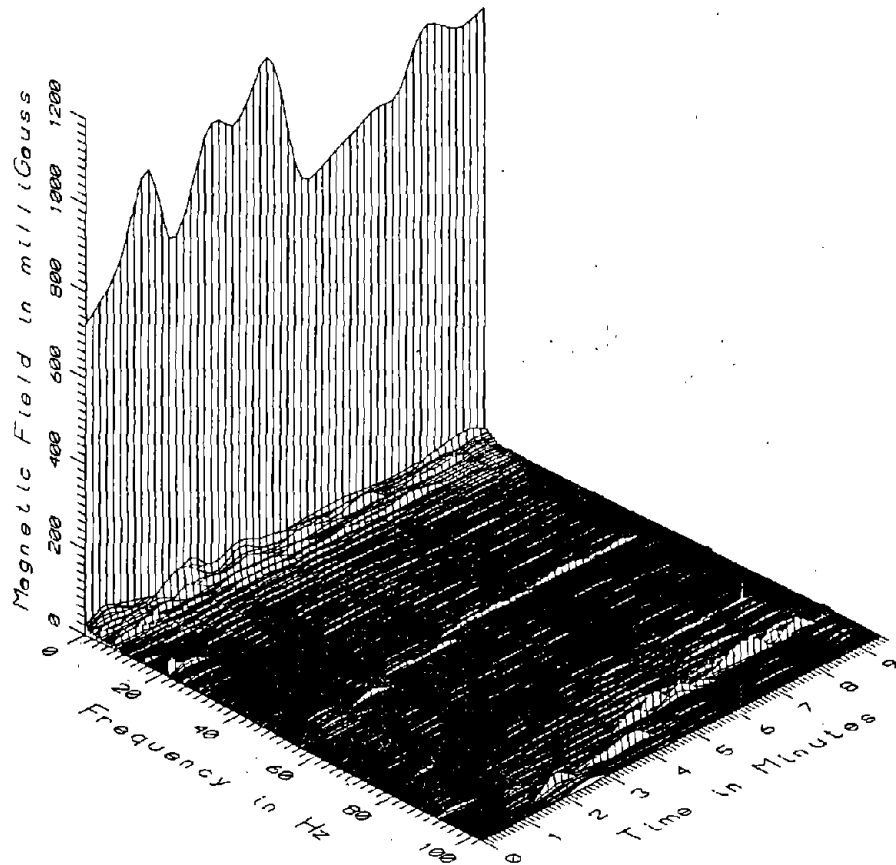

TR7010 - SEAT LEVEL - REAR ENGINE SECTION, CAR#2

G-8

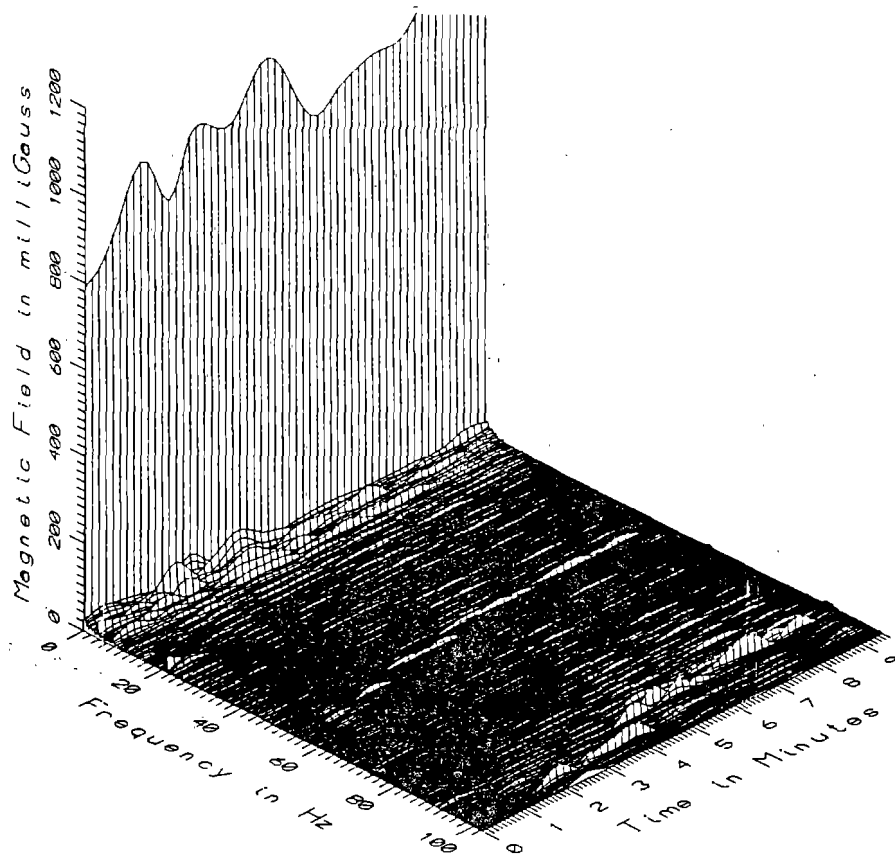

TR7010 - FLOOR LEVEL - REAR ENGINE SECTION, CAR#2

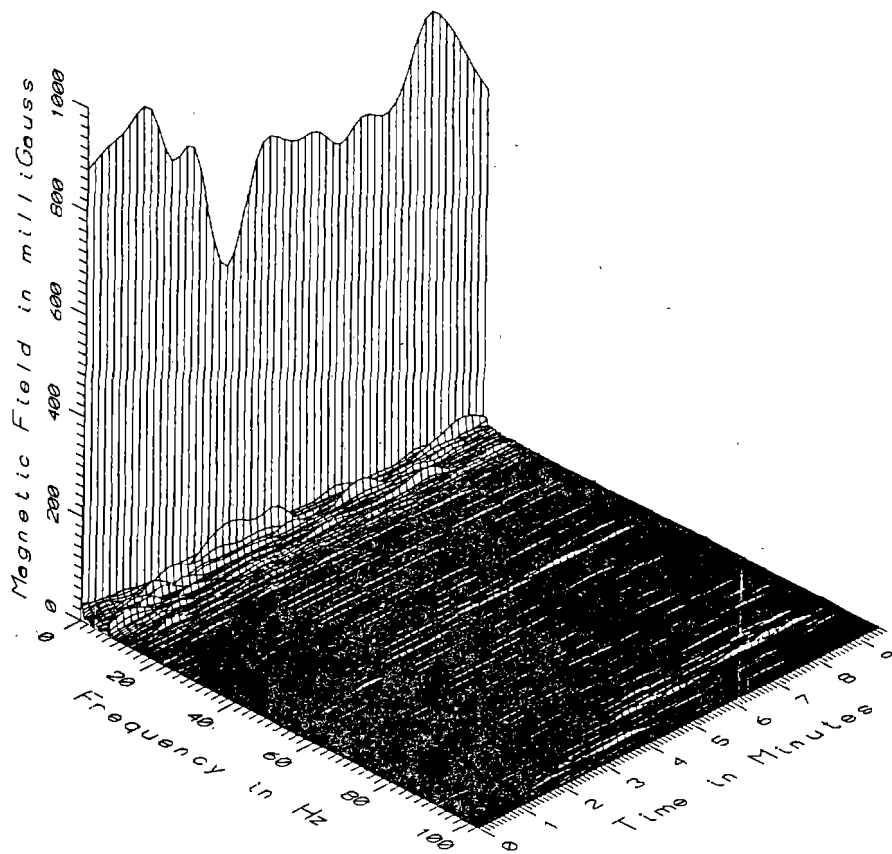

TR7010 - REFERENCE PROBE - BULKHEAD IN REAR OF PASSENGER SECTION, CAR#2

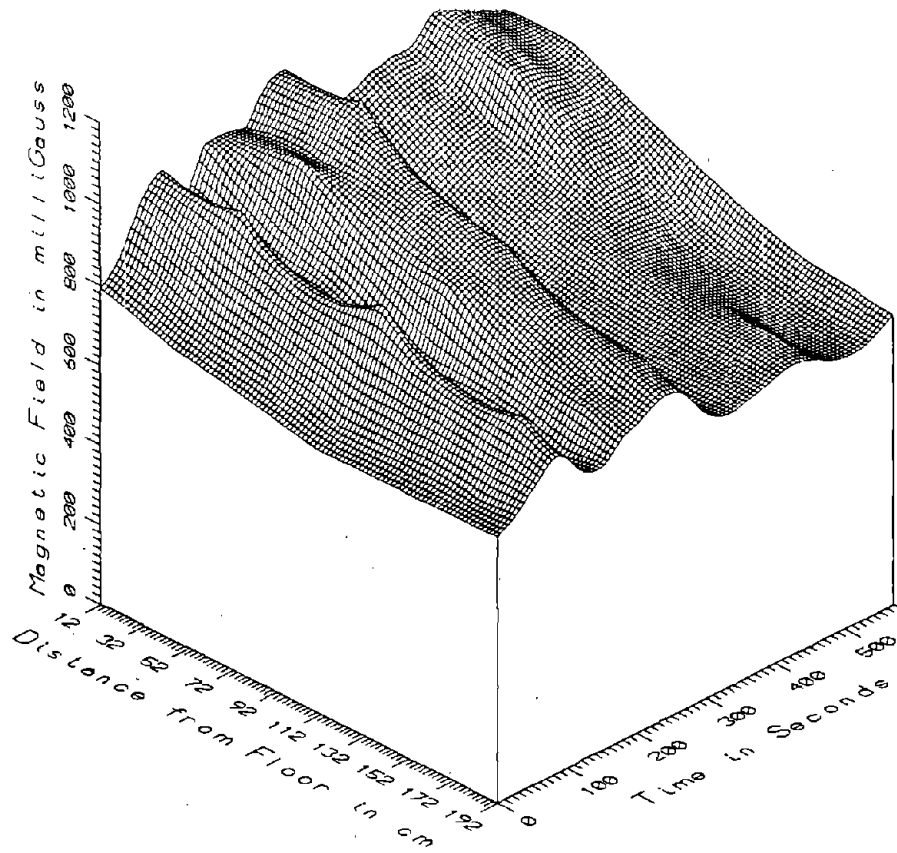

TR7010, REAR ENGINEER SECTION, CAR#2 - DC

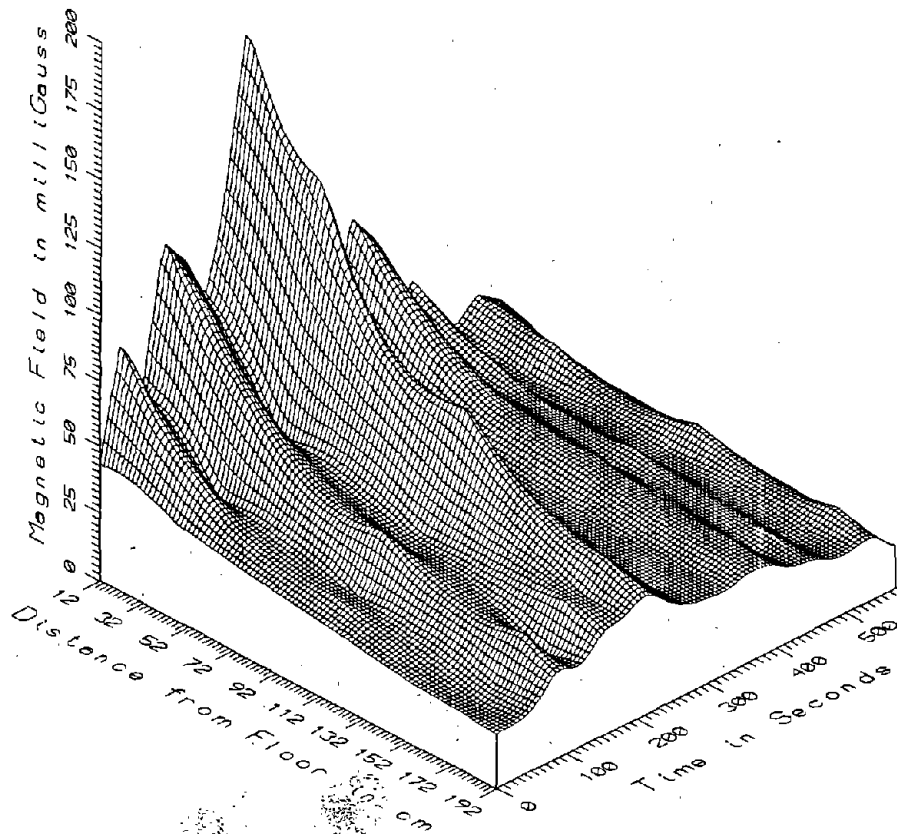

TR7010, REAR ENGINEER SECTION, CAR#2 - LOW FREQUENCY 5-45Hz

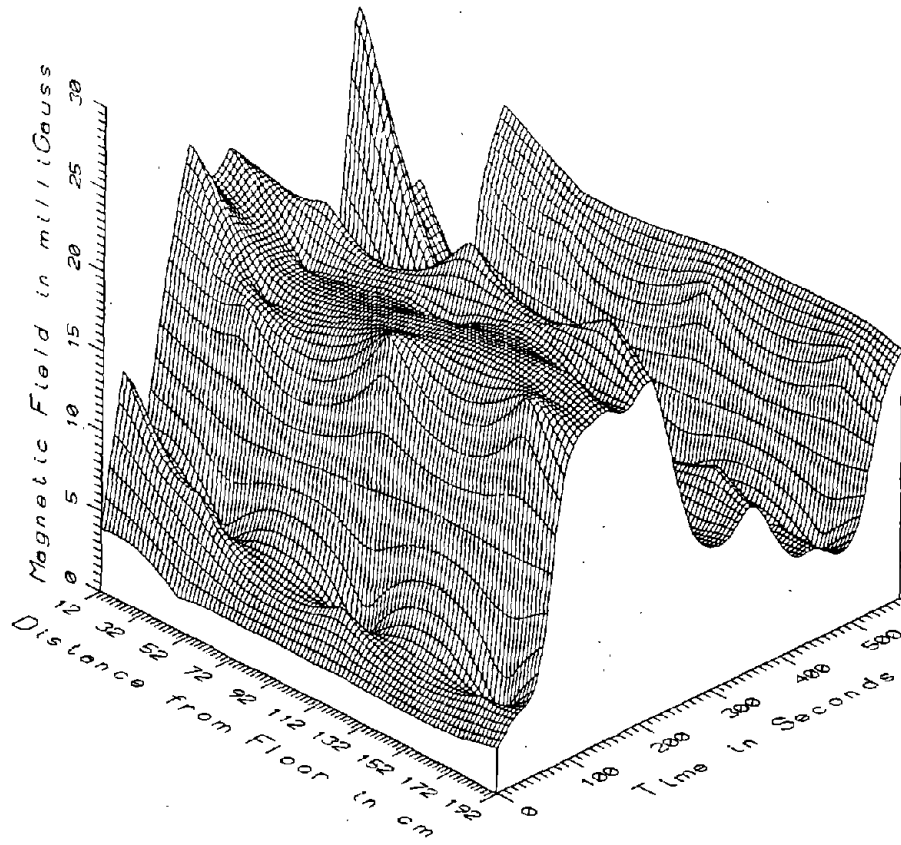

TR7010. REAR ENGINEER SECTION, CAR#2 - POWER FREQUENCY 50-60Hz

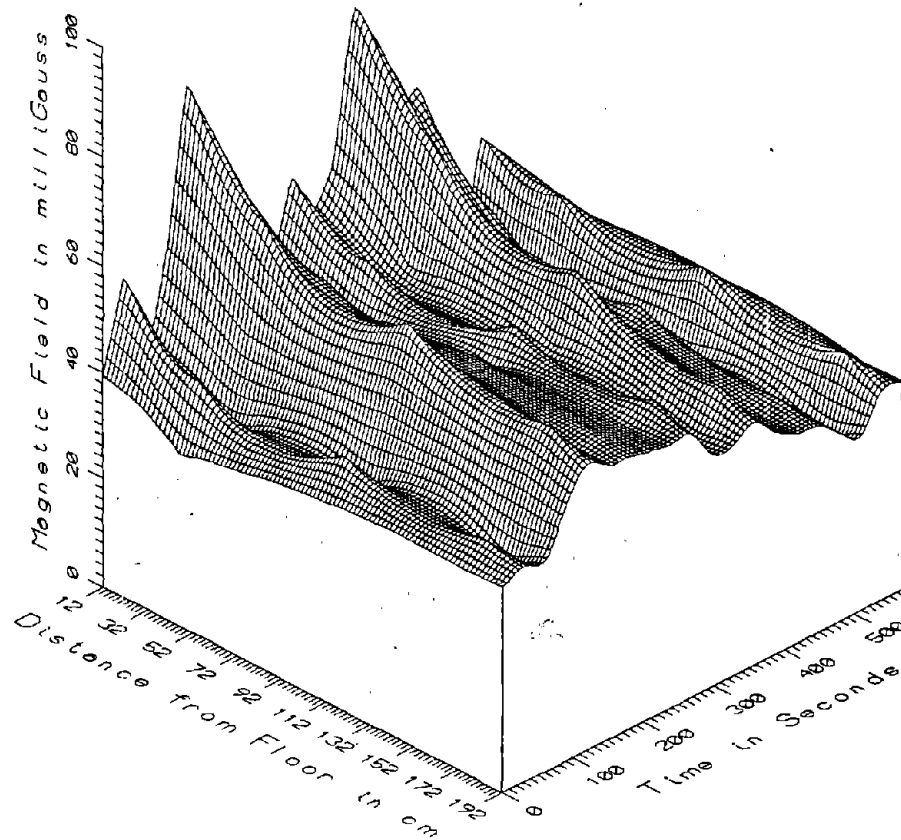

TR7010. REAR ENGINEER SECTION, CAR#2 - POWER HARMONICS 65-300Hz

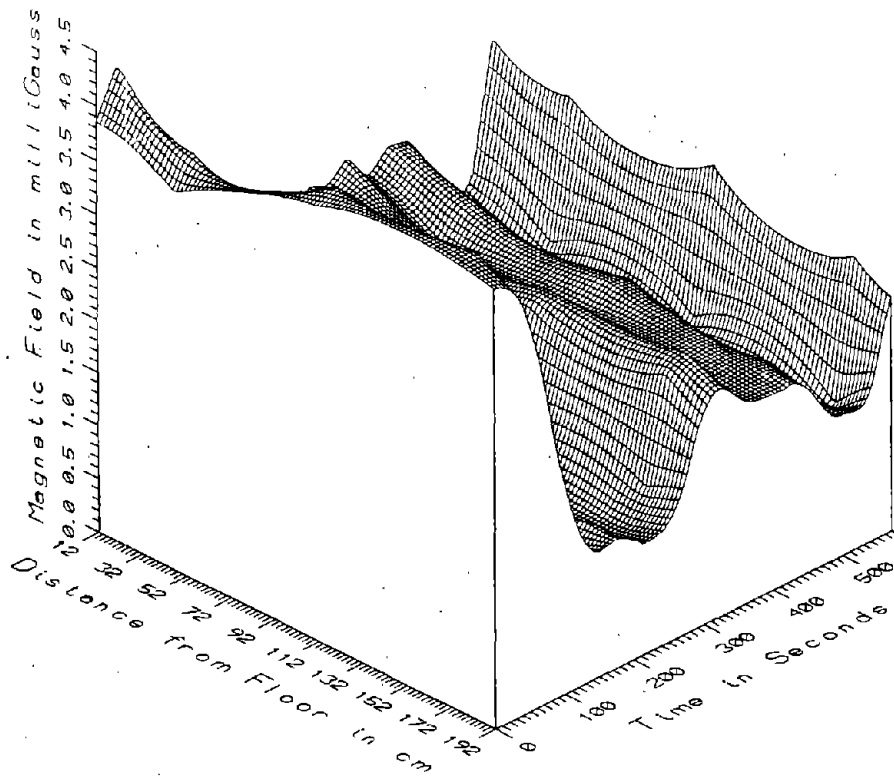

TR7010, REAR ENGINEER SECTION, CAR#2 - HIGH FREQUENCY 305-2560Hz

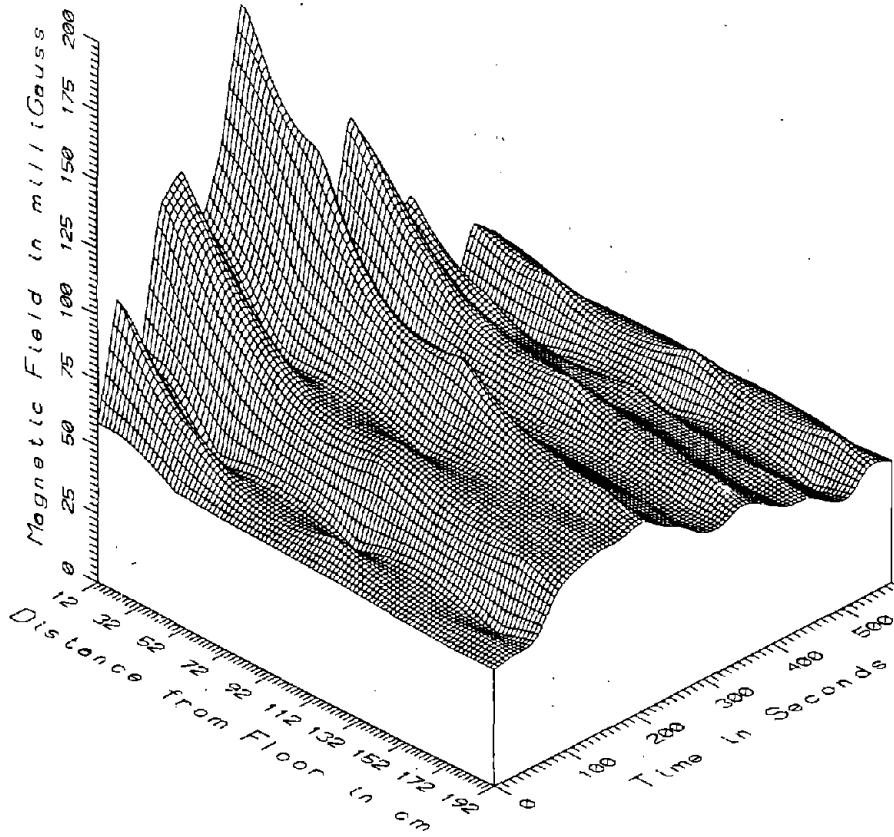

TR7010, REAR ENGINEER SECTION, CAR#2 - ALL FREQUENCIES 5-2560Hz

H-1

APPENDIX H

DATA SET TR7011

**VEHICLE PASSENGER SECTION, LATERAL PROFILE
AT FLOOR LEVEL, MID CAR**

H-1.

APPENDIX H

DATA SET TR7011
VEHICLE PASSENGER SECTION,
LATERAL PROFILE AT FLOOR LEVEL, MID CAR

Measurement Setup Code: 17
Vehicle Status: Running, Stop and Levitate, Running
Measurement Date: August 7, 1990
Measurement Time: Start: 18:17:30
End: 18:20:00
Number of Samples: 6
Programmed Sample Interval: 30 sec
Actual Sample Interval: 30 sec

Frequency Spectrum Parameters

<u>Probe Type:</u>	<u>Coil (AC)</u>	<u>Fluxgate (DC)</u>
Maximum Frequency (Hz)	2560	102.4
Minimum Frequency (Hz)	5	0
Spectral Bandwidth (Hz)	5	0.2

Missing or Suspect Data: The fluxgate sensors at floor level at the aisle and window seat locations saturated on the vertical axis during the last sample (vehicle accelerating from a stop).

ON-VEHICLE MEASUREMENT POINTS (AUG. 7, '90)

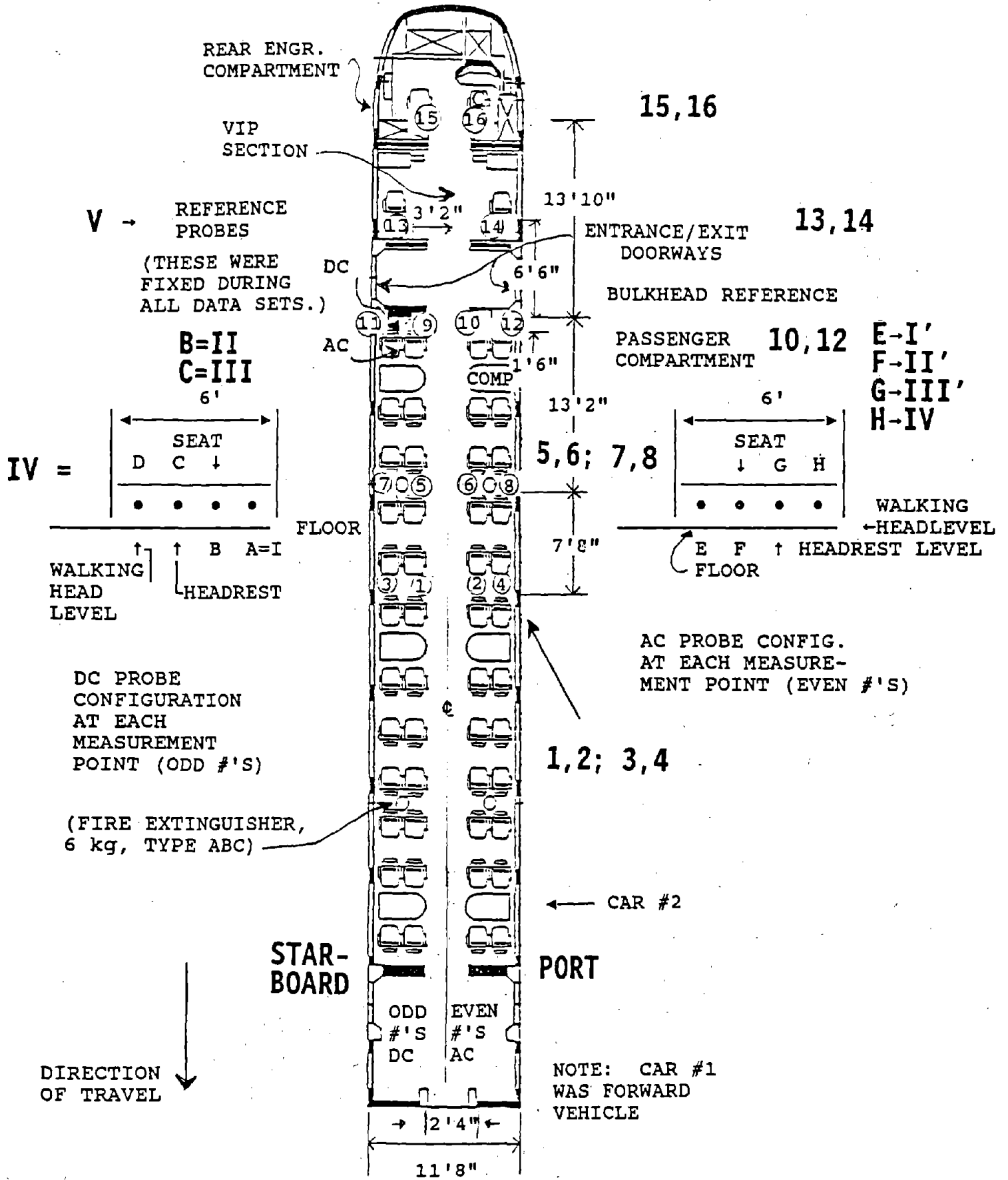

H-2

VEHICLE SPEED - TR7011

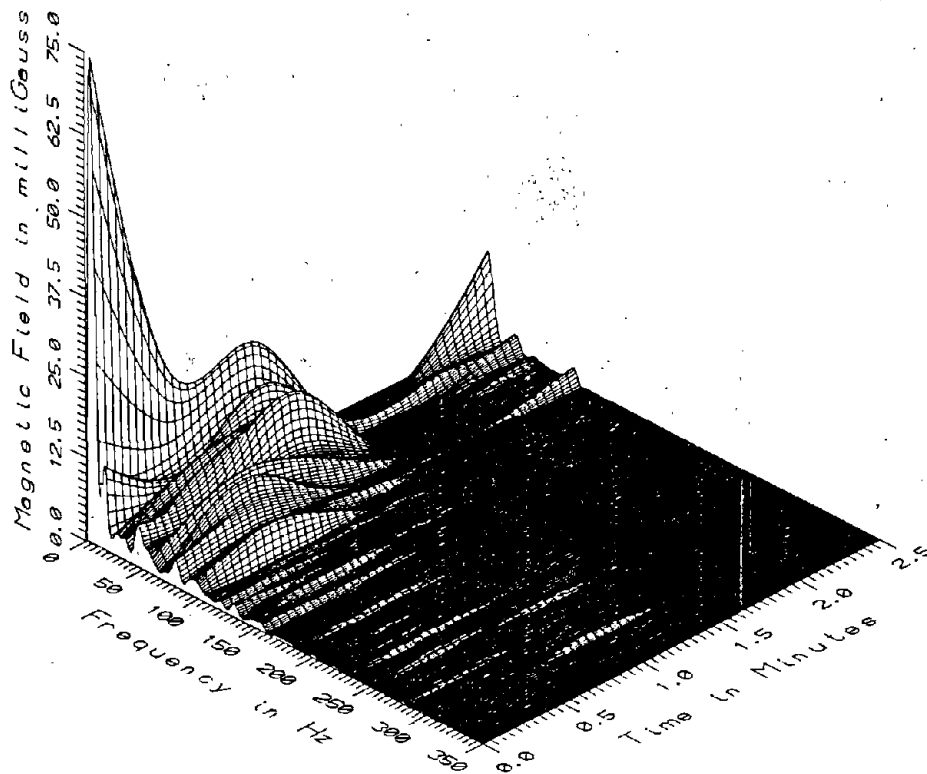
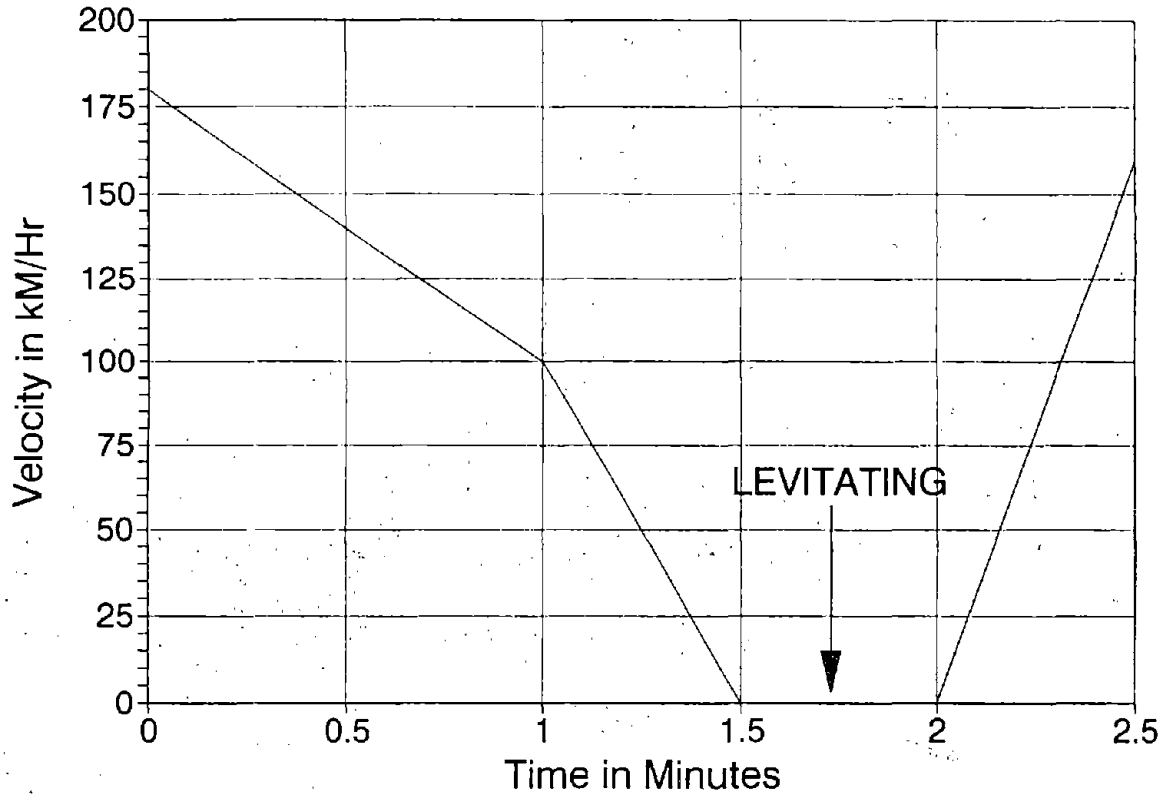

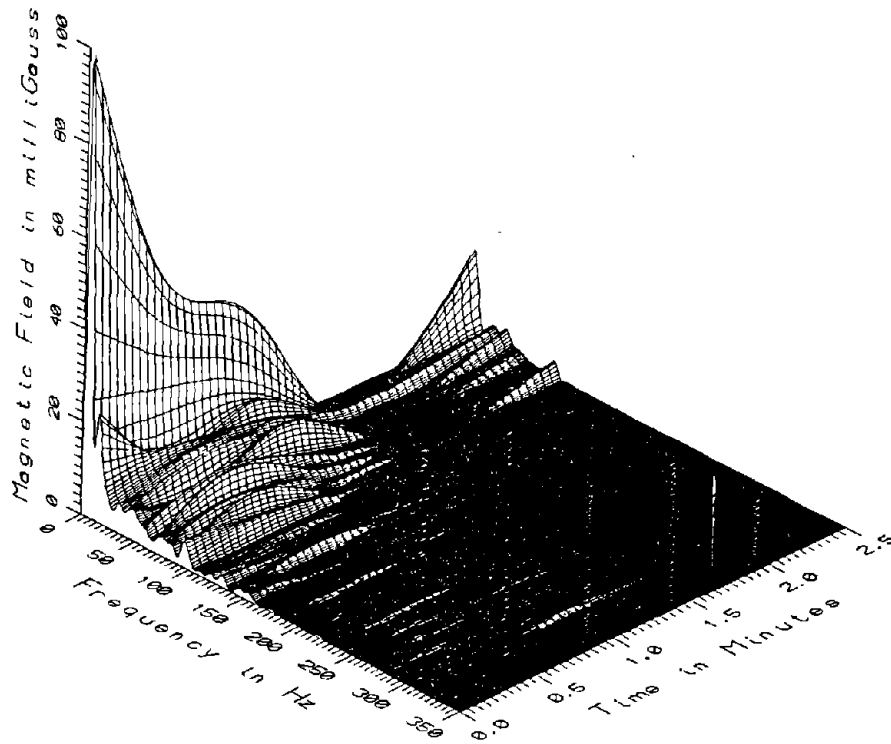

TR7011 - EDGE OF AISLE - FLOOR LEVEL IN MIDDLE OF PASSENGER SECTION, CAR#2

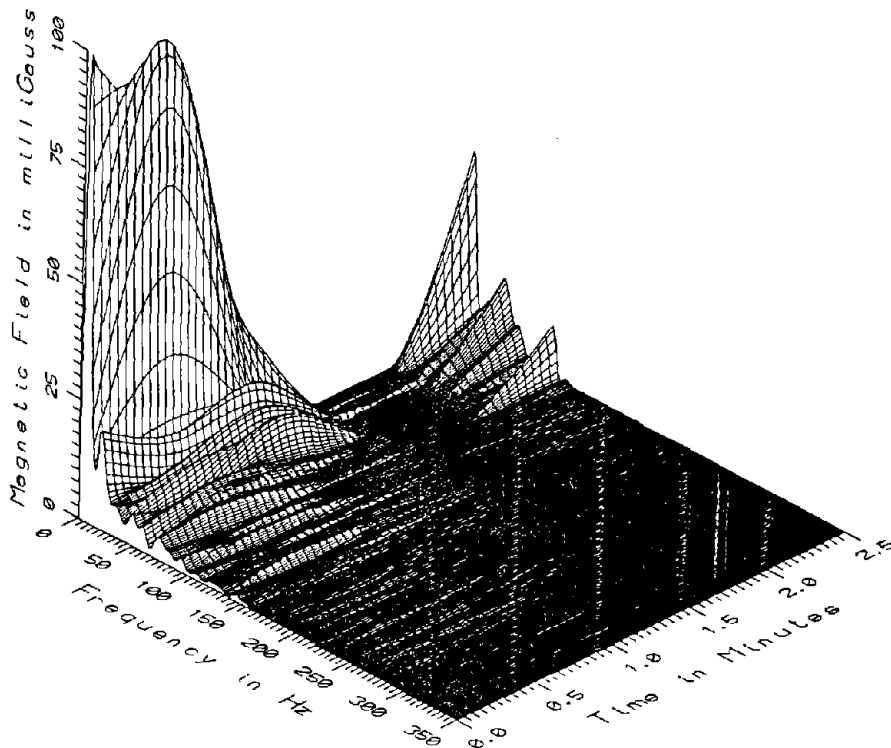

TR7011 - AISLE SEAT - FLOOR LEVEL IN MIDDLE OF PASSENGER SECTION, CAR#2

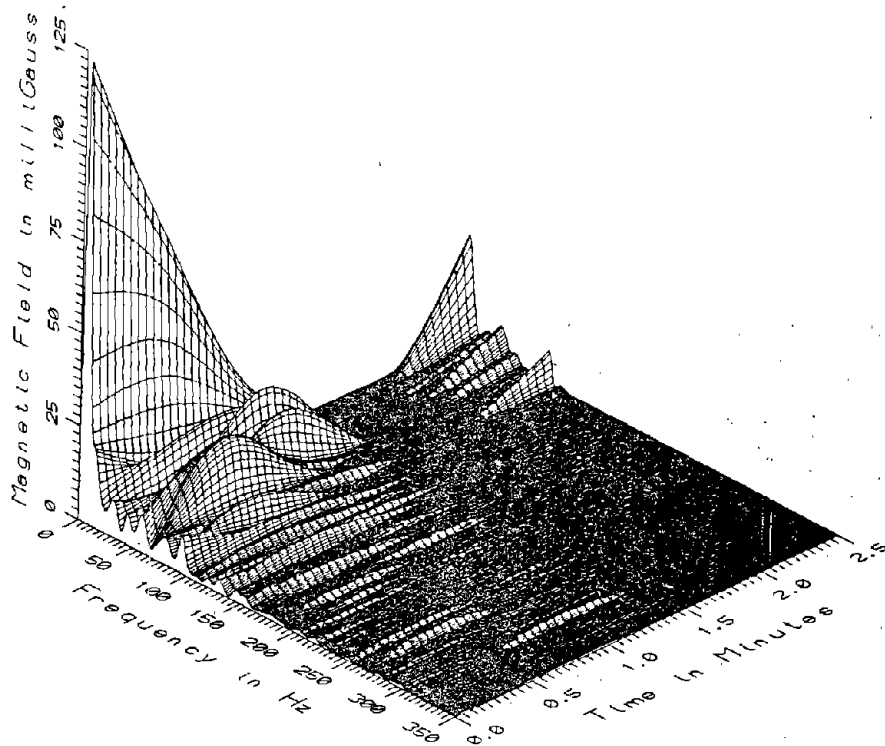

TR7011 - WINDOW SEAT - FLOOR LEVEL IN MIDDLE OF PASSENGER SECTION, CAR#2

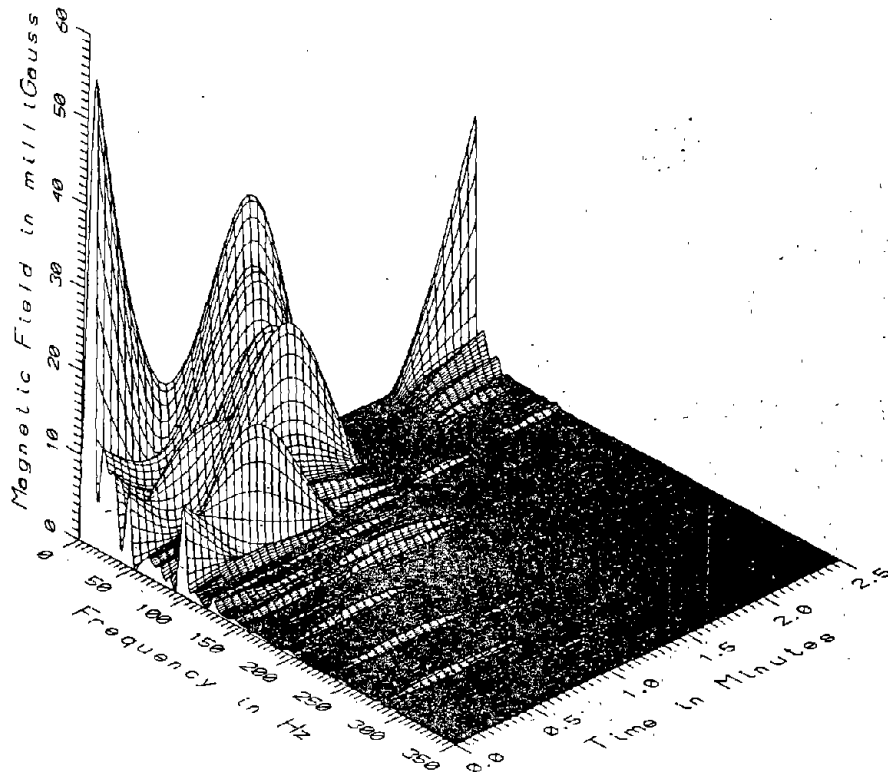

TR7011 - REFERENCE PROBE - BULKHEAD IN REAR OF PASSENGER SECTION, CAR#2

H-5

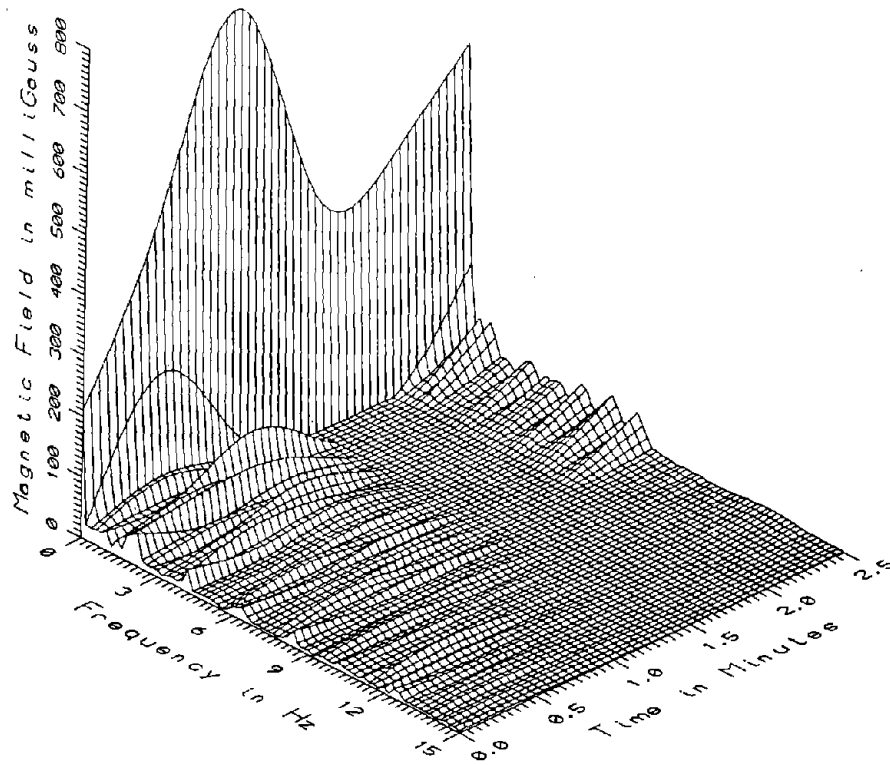

TR7011 - CENTER OF AISLE - FLOOR LEVEL IN MIDDLE OF PASSENGER SECTION, CAR#2

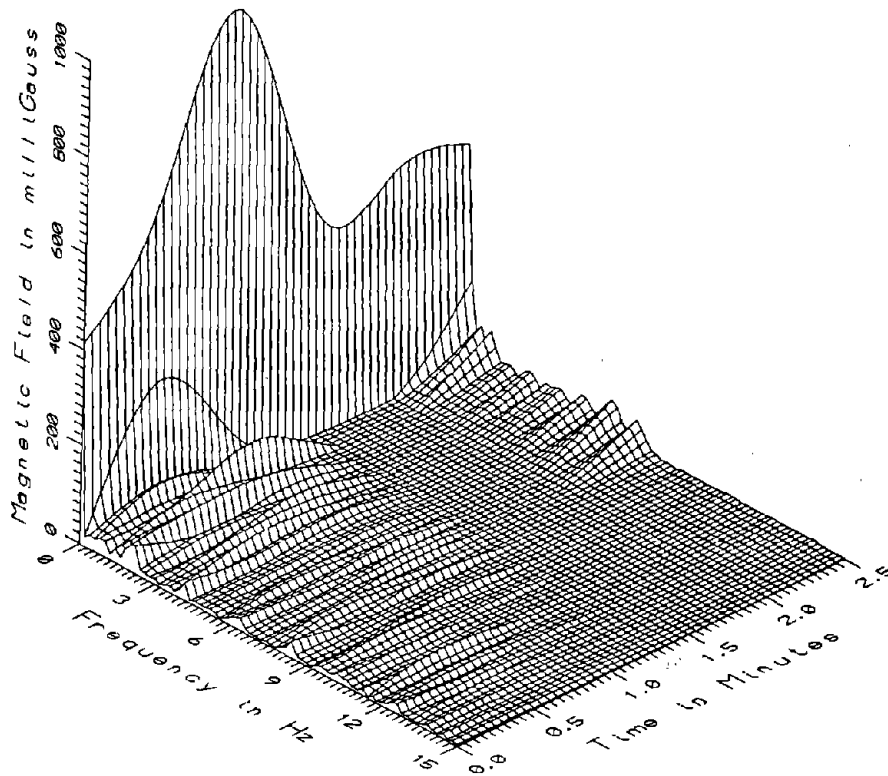

TR7011 - EDGE OF AISLE - FLOOR LEVEL IN MIDDLE OF PASSENGER SECTION, CAR#2

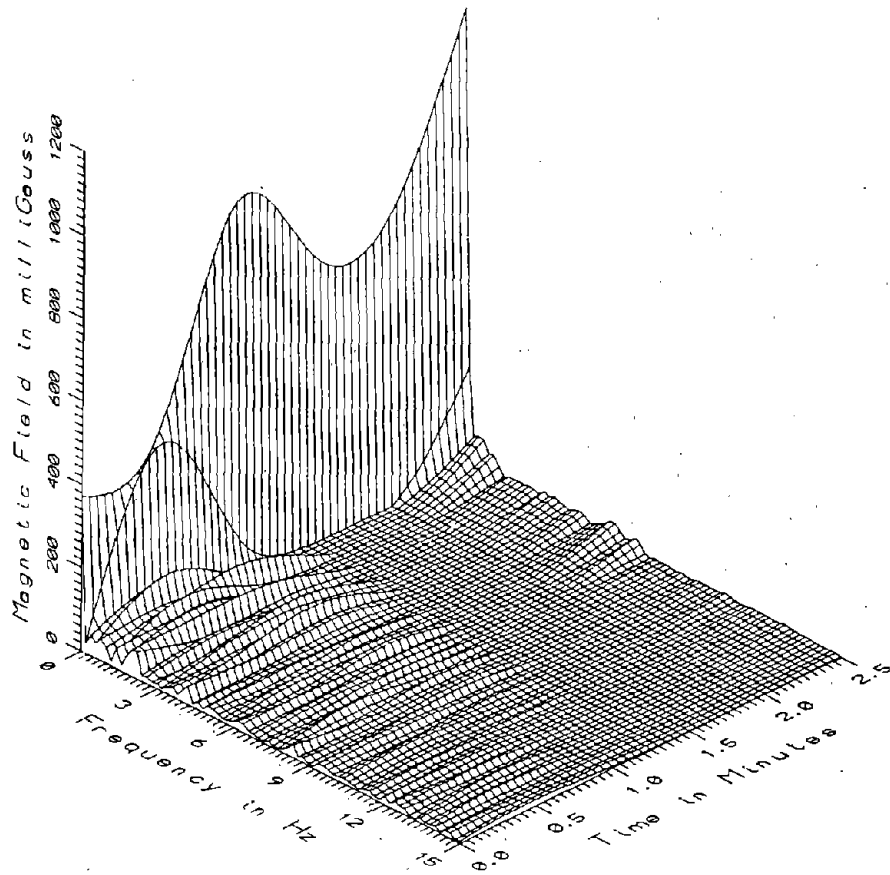

TR7011 - AISLE SEAT - FLOOR LEVEL IN MIDDLE OF PASSENGER SECTION, CAR#2

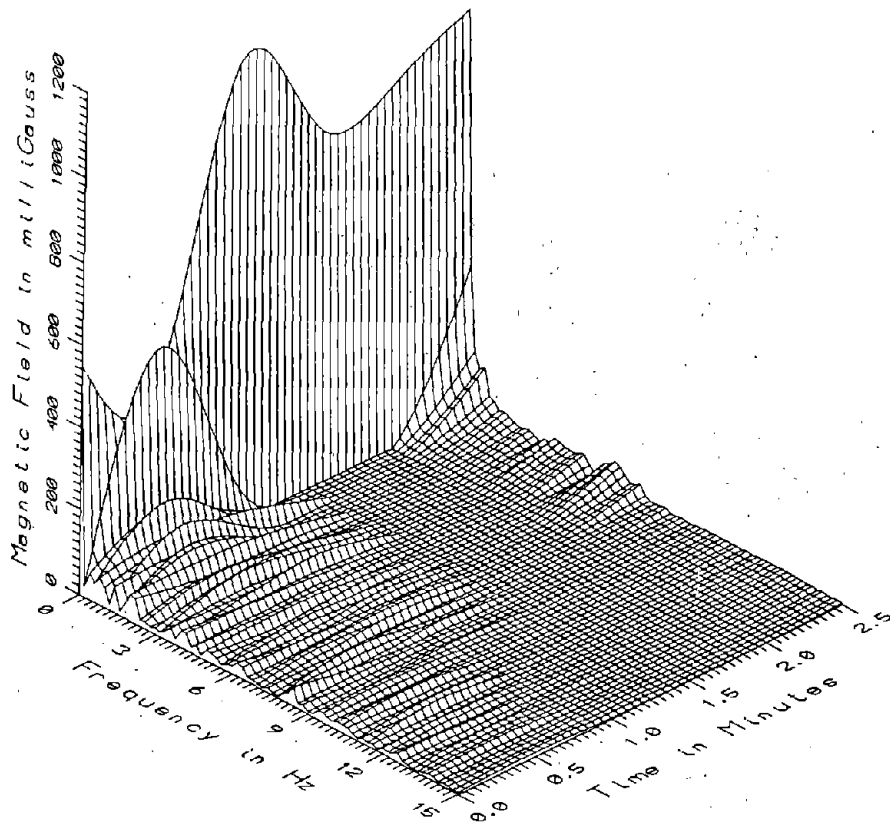

TR7011 - WINDOW SEAT - FLOOR LEVEL IN MIDDLE OF PASSENGER SECTION, CAR#2

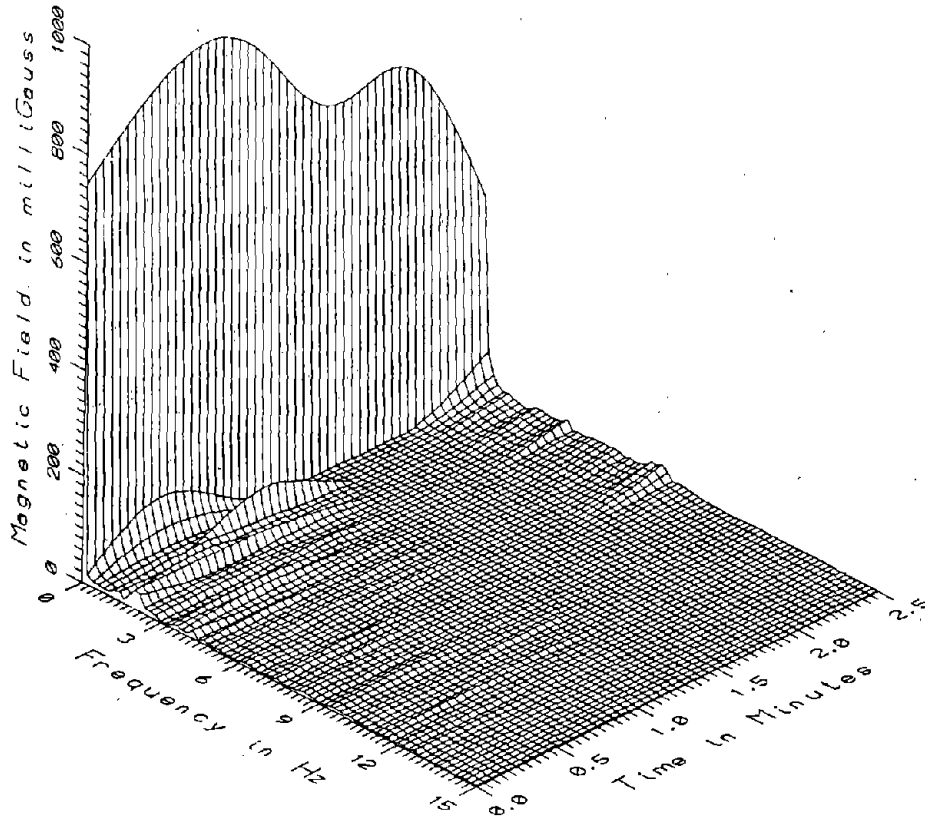

TR7011 - REFERENCE PROBE - BULKHEAD AT REAR OF PASSENGER SECTION, CAR#2

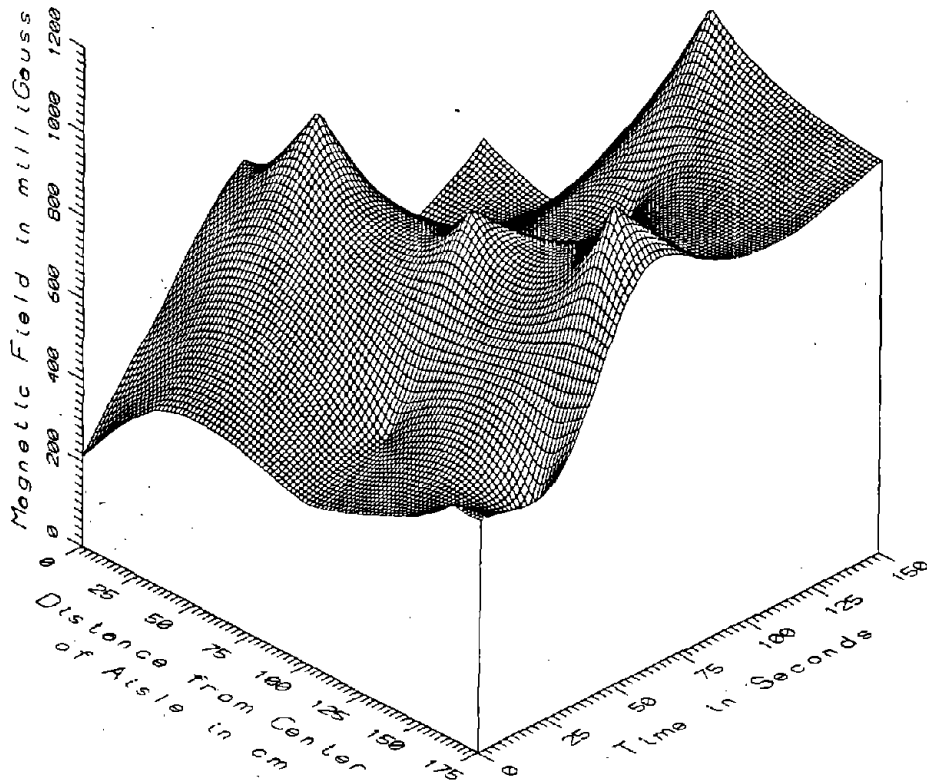

TR7011, FLOOR LEVEL IN MIDDLE OF PASSENGER SECTION, CAR2 - DC

H-8

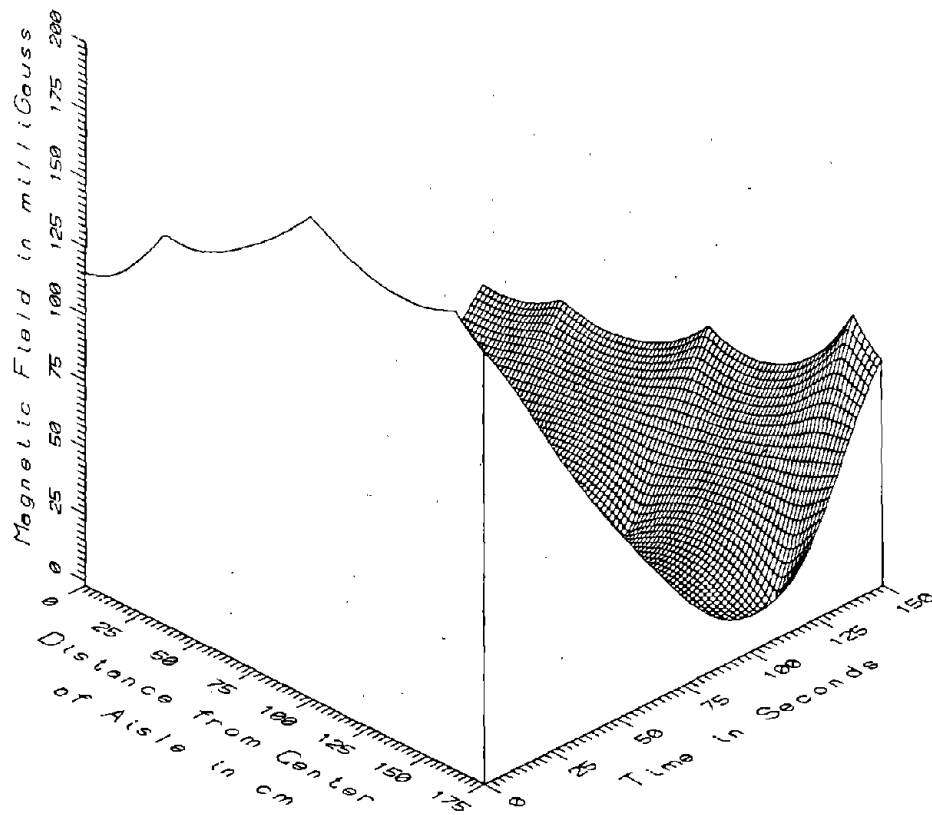

TR7011, FLOOR LEVEL IN MIDDLE OF PASSENGER SECTION, CAR2 - LOW FREQUENCY, 5-45Hz

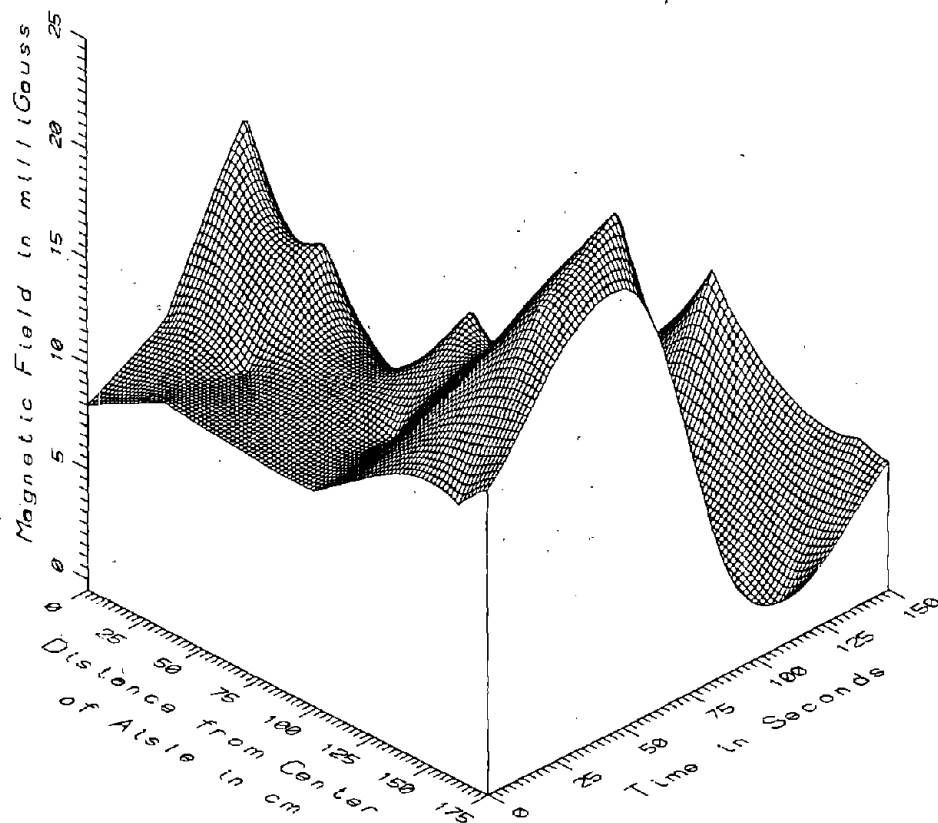

TR7011, FLOOR LEVEL IN MIDDLE OF PASSENGER SECTION, CAR2 - POWER FREQ. 50-60Hz

H-9

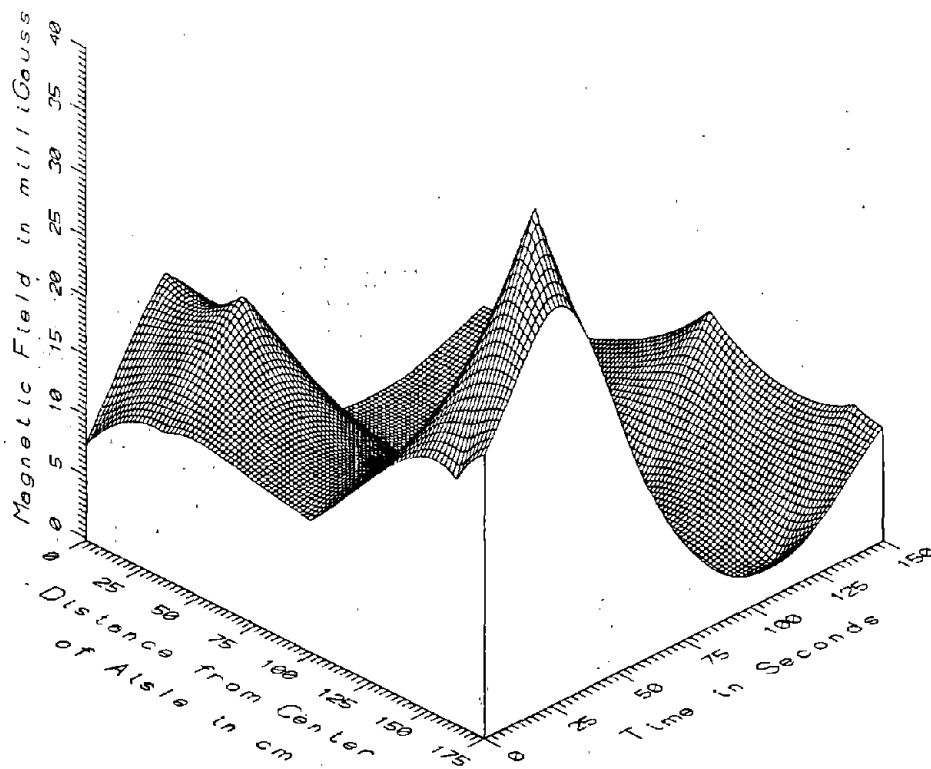

TR7011, FLOOR LEVEL IN MIDDLE OF PASSENGER SECTION, CAR2 - POWER HARM. 65-300Hz

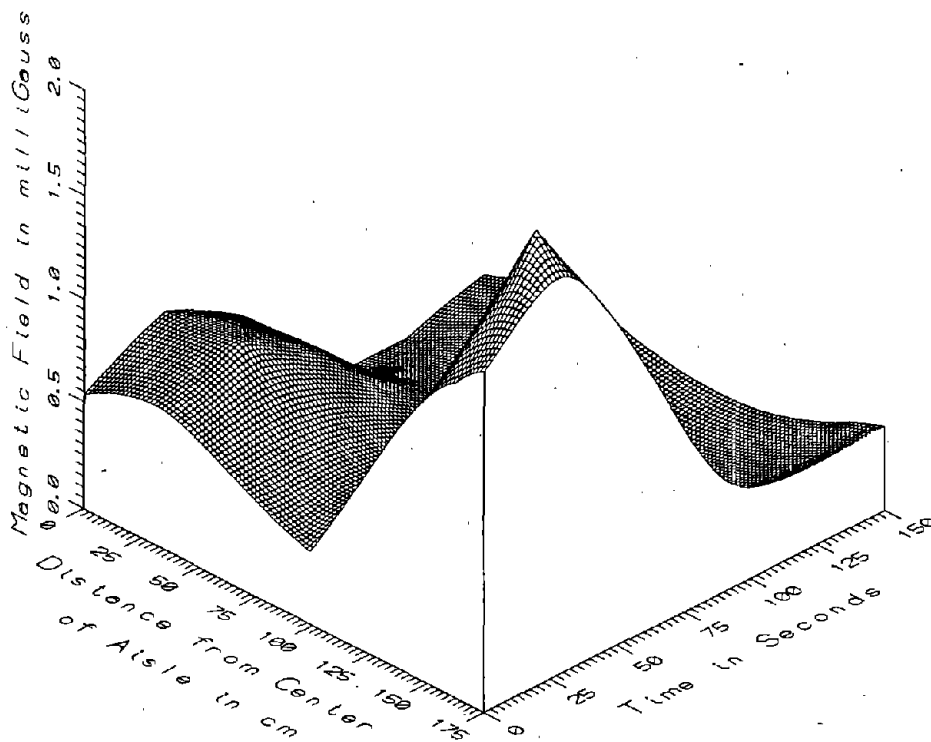

TR7011, FLOOR LEVEL IN MIDDLE OF PASSENGER SECTION, CAR2 - HIGH FREQ. 305-2560

H-11

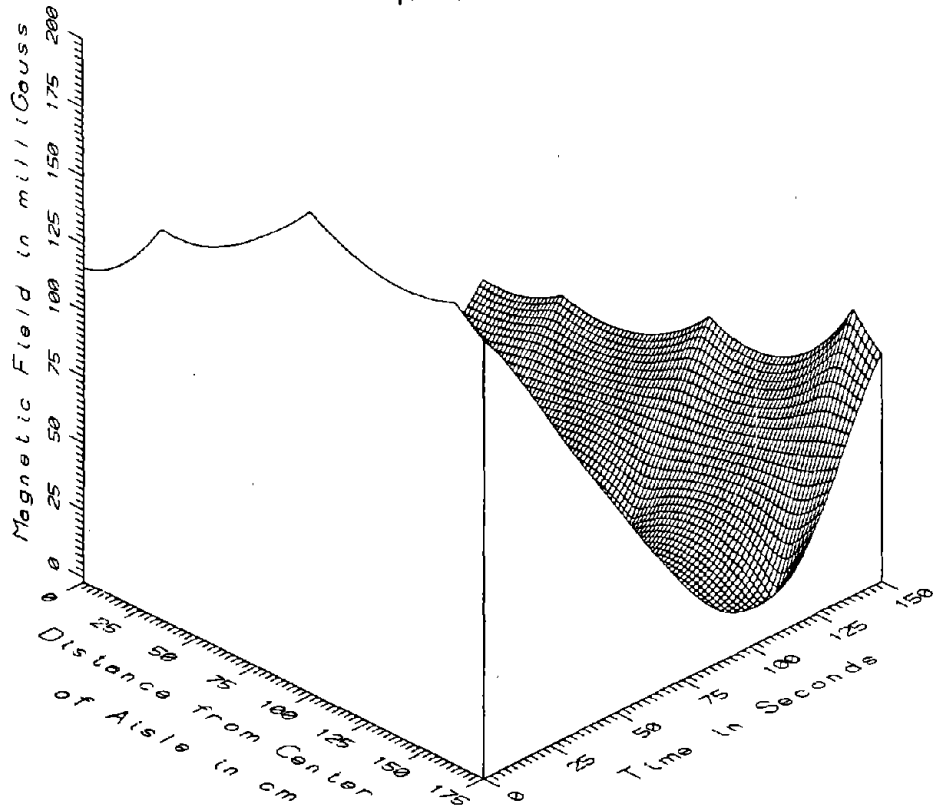

TR7011, FLOOR LEVEL IN MIDDLE OF PASSENGER SECTION, CAR2 - ALL FREQ. 5-2560Hz

I-i

APPENDIX I

DATA SET TR7012

**LATERAL PROFILE
BENEATH THE HIGH STEEL GUIDEWAY**

APPENDIX I

DATA SET TR7012
LATERAL PROFILE BENEATH THE HIGH STEEL GUIDEWAY

Measurement Setup Code: 18
Vehicle Status: Running continuously
Measurement Date: August 8, 1990
Measurement Time: Start: 10:42:50
End: 10:47:12
Number of Samples: 6*
Programmed Sample Interval: 30 sec
Actual Sample Interval: 6 sec

Frequency Spectrum Parameters

<u>Probe Type:</u>	<u>Coil (AC)</u>	<u>Fluxgate (DC)</u>
Maximum Frequency (Hz)	2560	256
Minimum Frequency (Hz)	5	0
Spectral Bandwidth (Hz)	5	0.5

Missing or Suspect Data: None

* Measurements were suspended while vehicle was in the south loop

SETUP 18, 19: HIGH-STEEL GUIDEWAY, PILLAR 2423 NEAR CONTROL CENTER

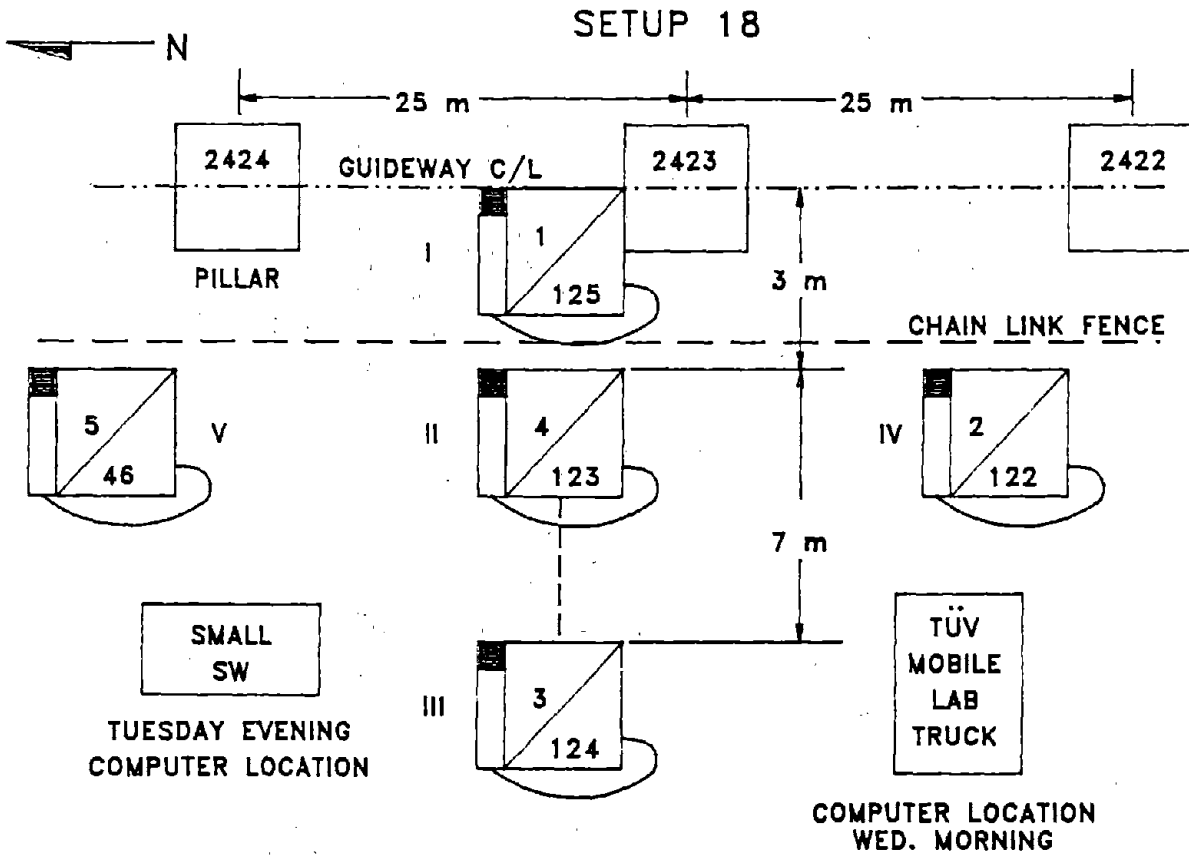

TOP VIEW OF ALL PROBE ORIENTATIONS

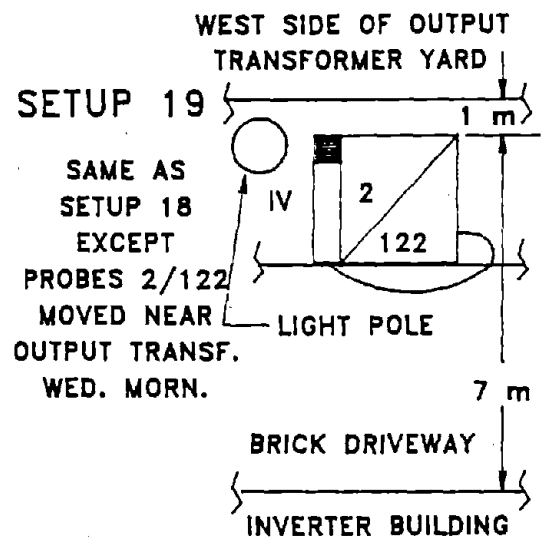
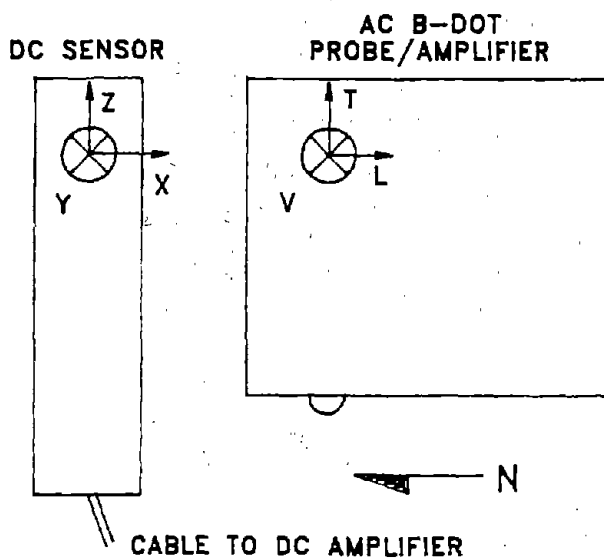

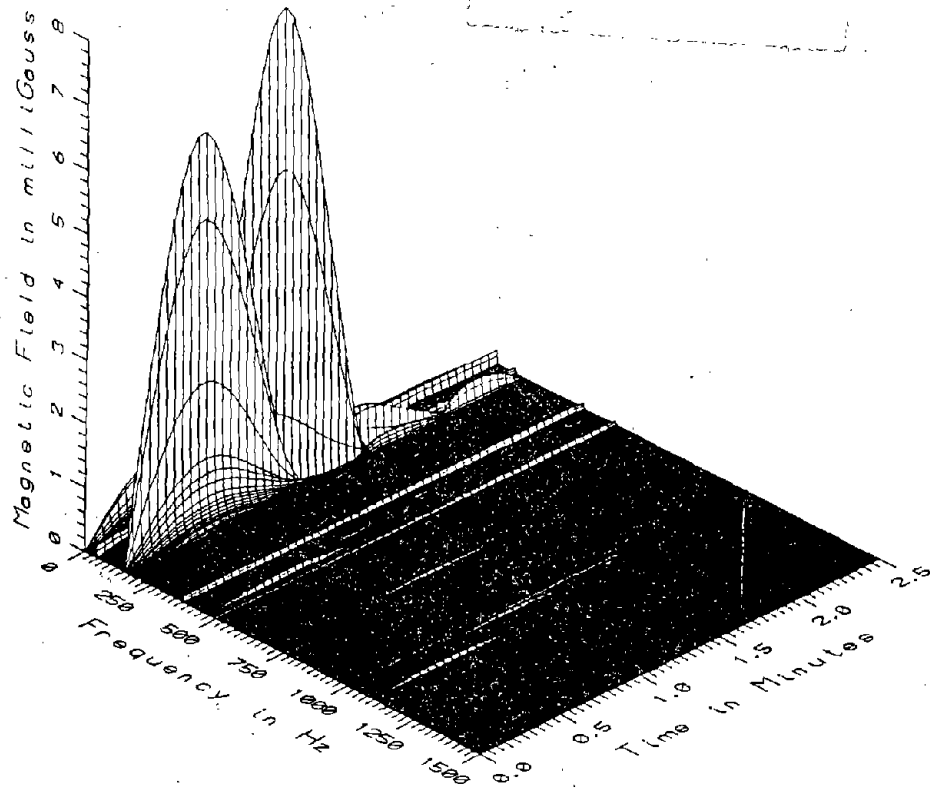

TR7012 - PROFILE OF HIGH STEEL GUIDEWAY - UNDER CENTER OF GUIDEWAY

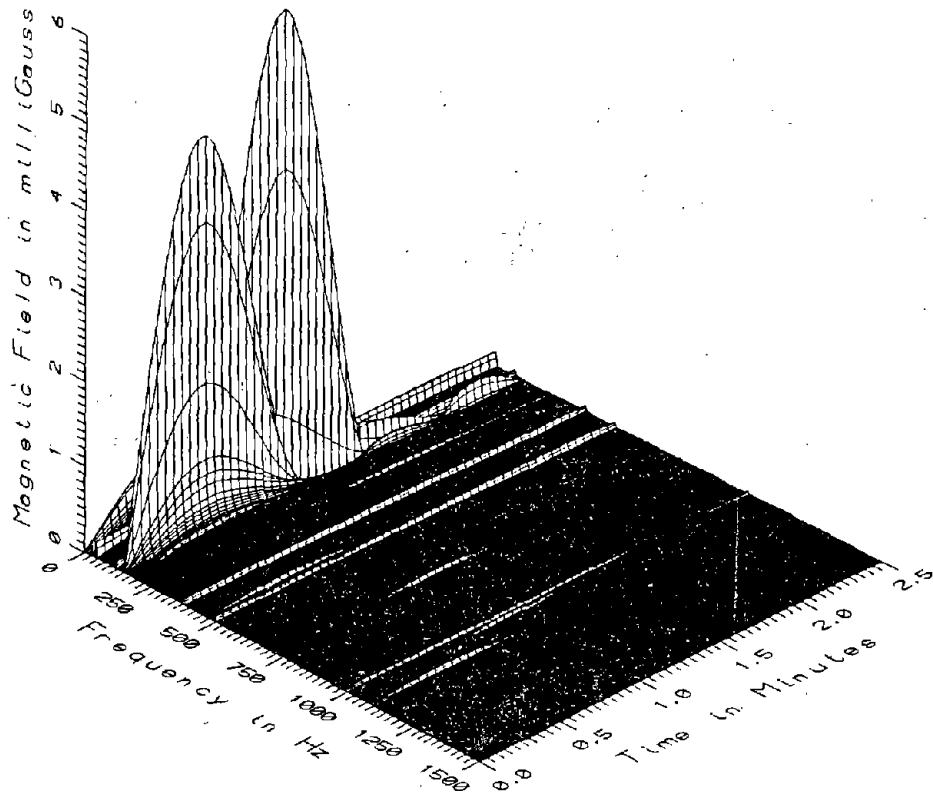

TR7012 - PROFILE OF HIGH STEEL GUIDEWAY 3M FROM CENTER OF GUIDEWAY

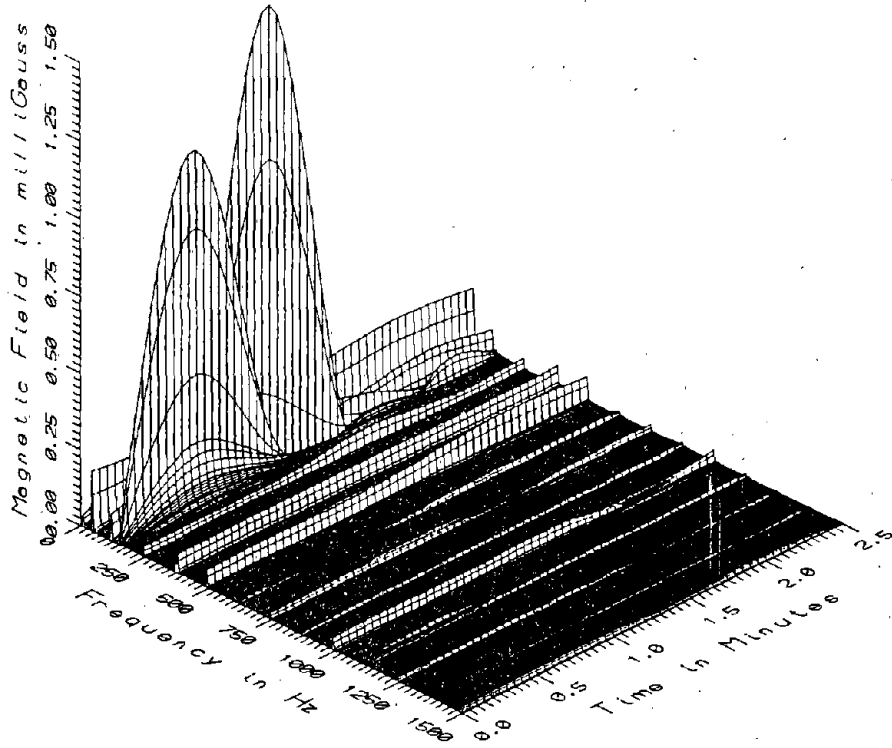

TR7012 - PROFILE OF HIGH STEEL GUIDEWAY - 10M FROM CENTER OF GUIDEWAY

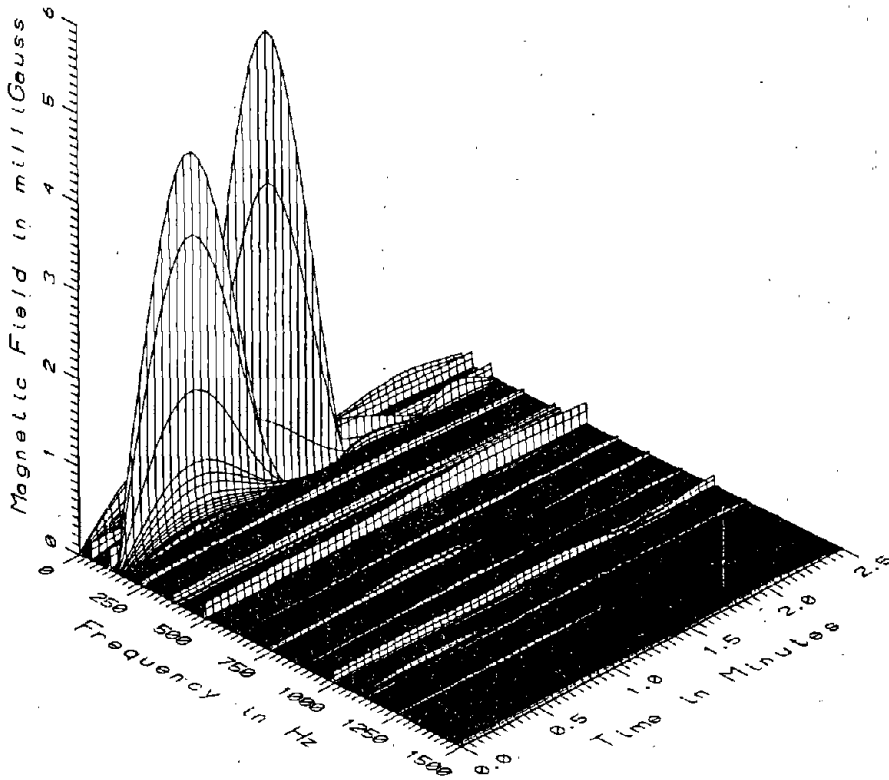

TR7012 - PROFILE OF HIGH STEEL GUIDEWAY - 3M FROM CENTER OF GUIDEWAY, 25M SOUTH

I-5

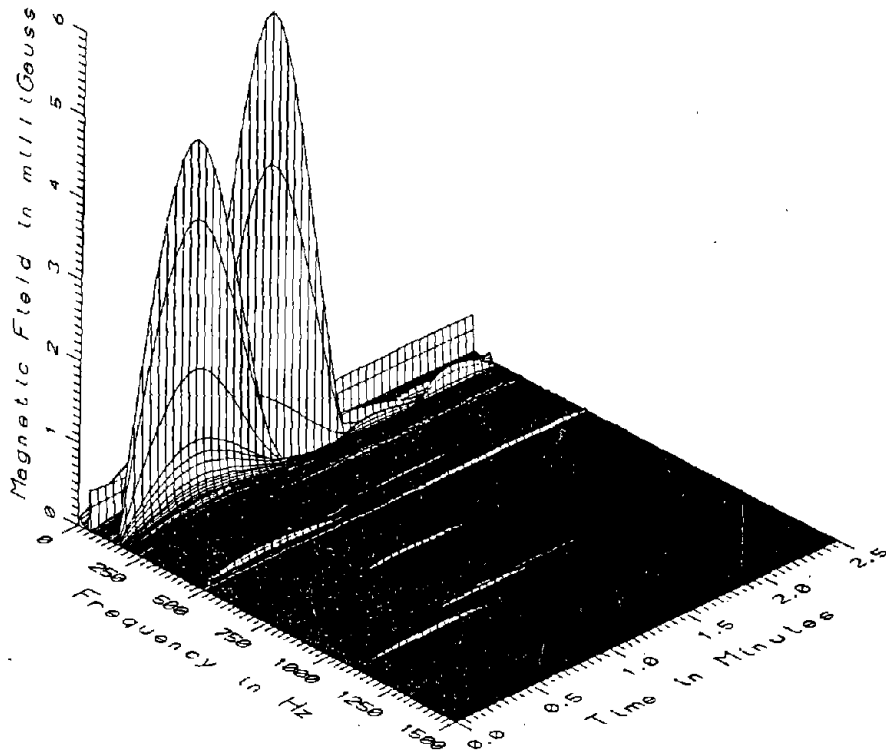

TR7012 - PROFILE OF HIGH STEEL GUIDEWAY - 3M FROM CENTER OF GUIDEWAY, 25M NORTH

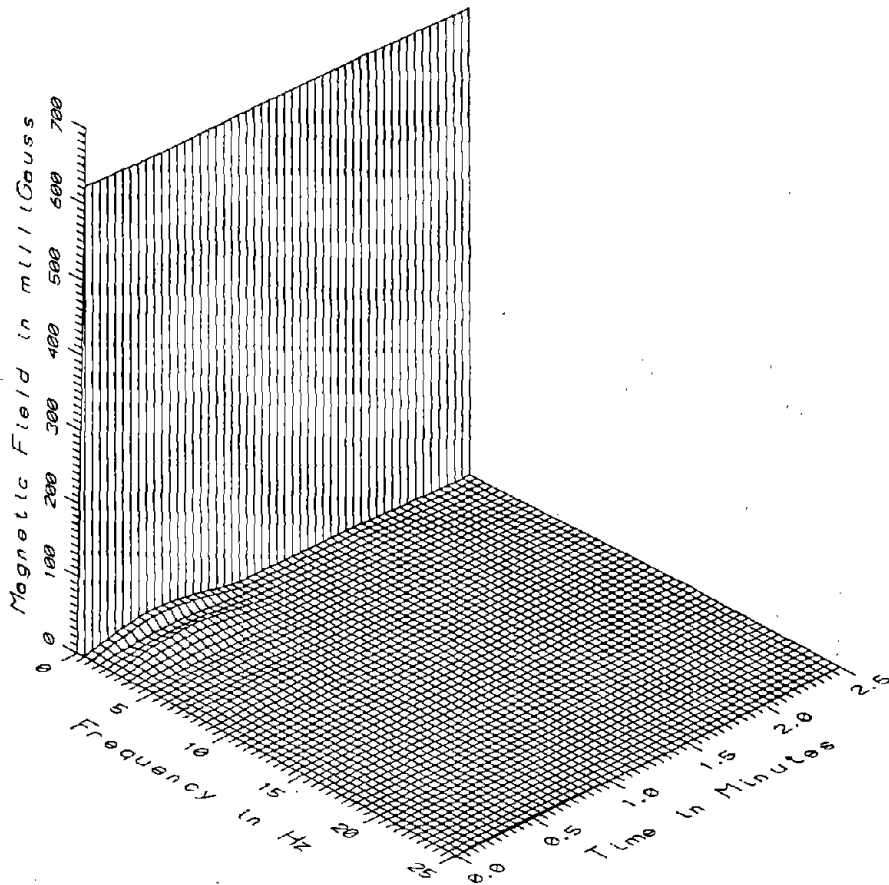

TR7013 UNDER CENTER OF HIGH STEEL GUIDEWAY

I-5

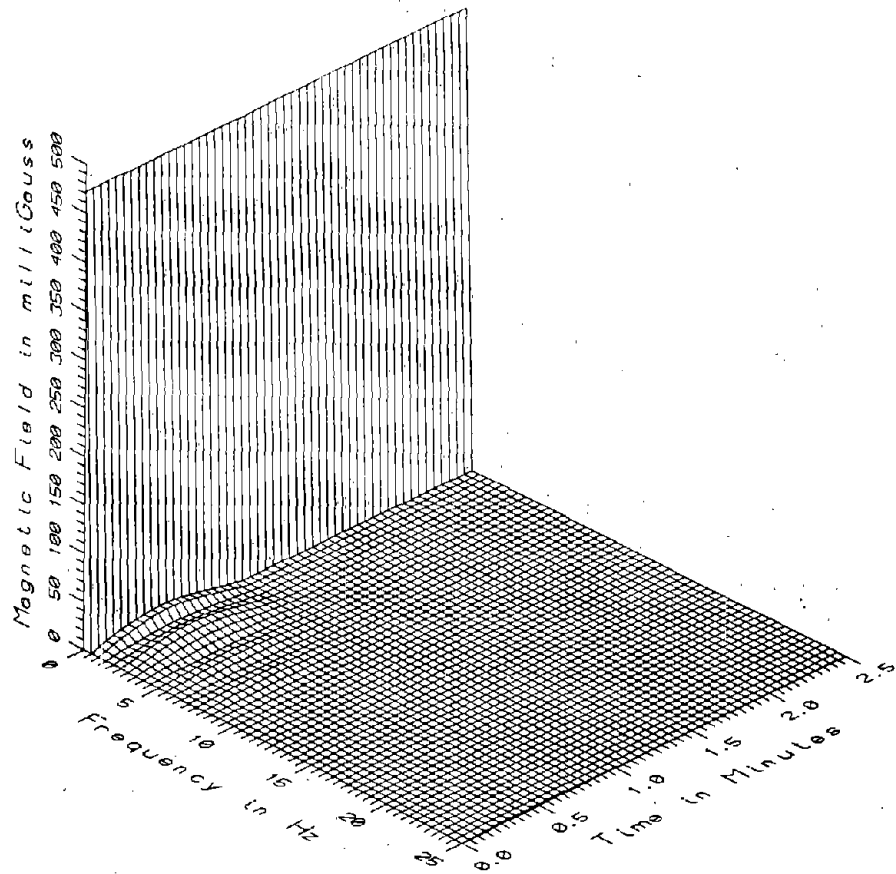

TR7012 - 3M WEST OF HIGH STEEL GUIDEWAY

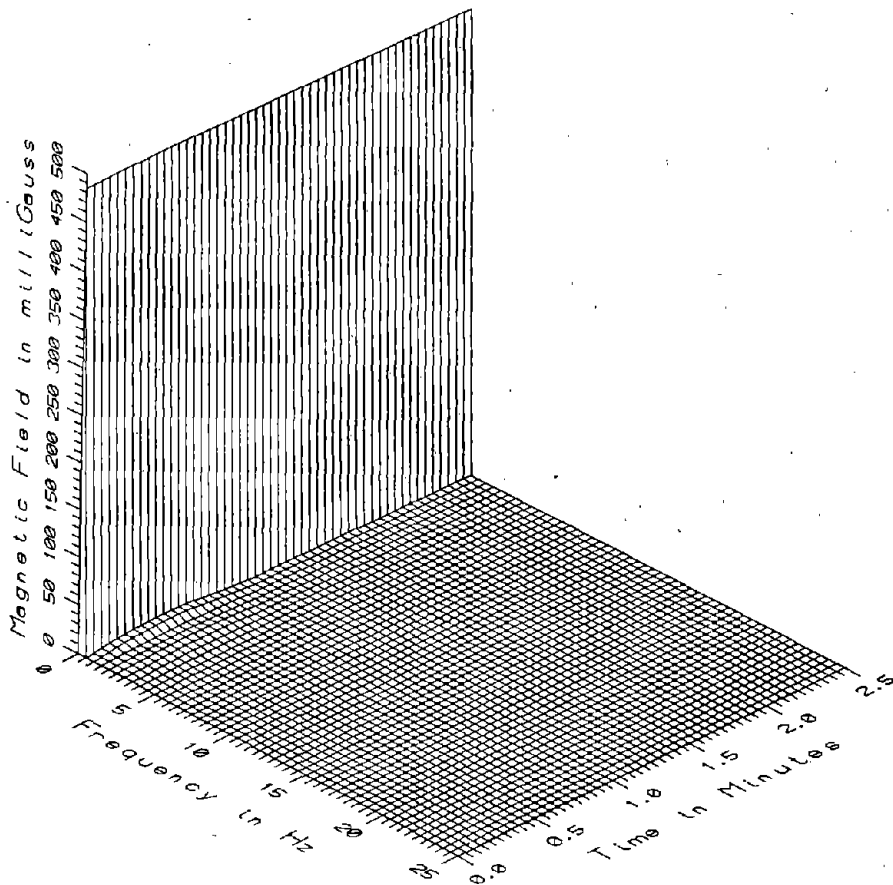

TR7012 - 10M WEST OF HIGH STEEL GUIDEWAY

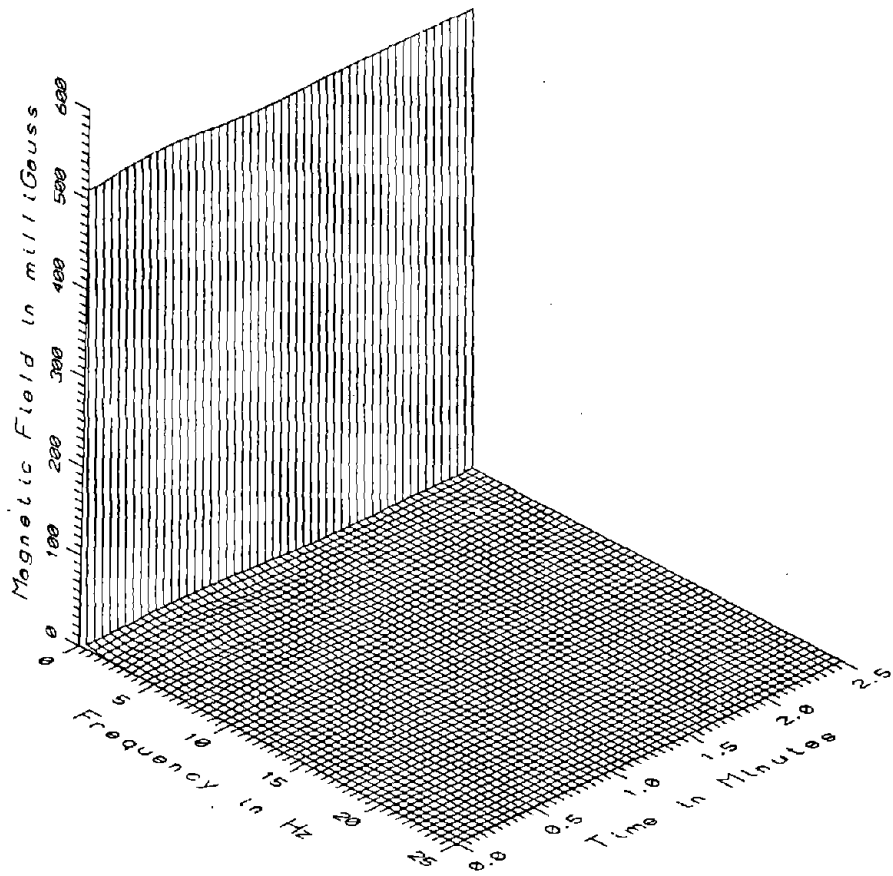

TR7012 - 3M WEST OF HIGH STEEL GUIDEWAY, 25M SOUTH OF PROFILE

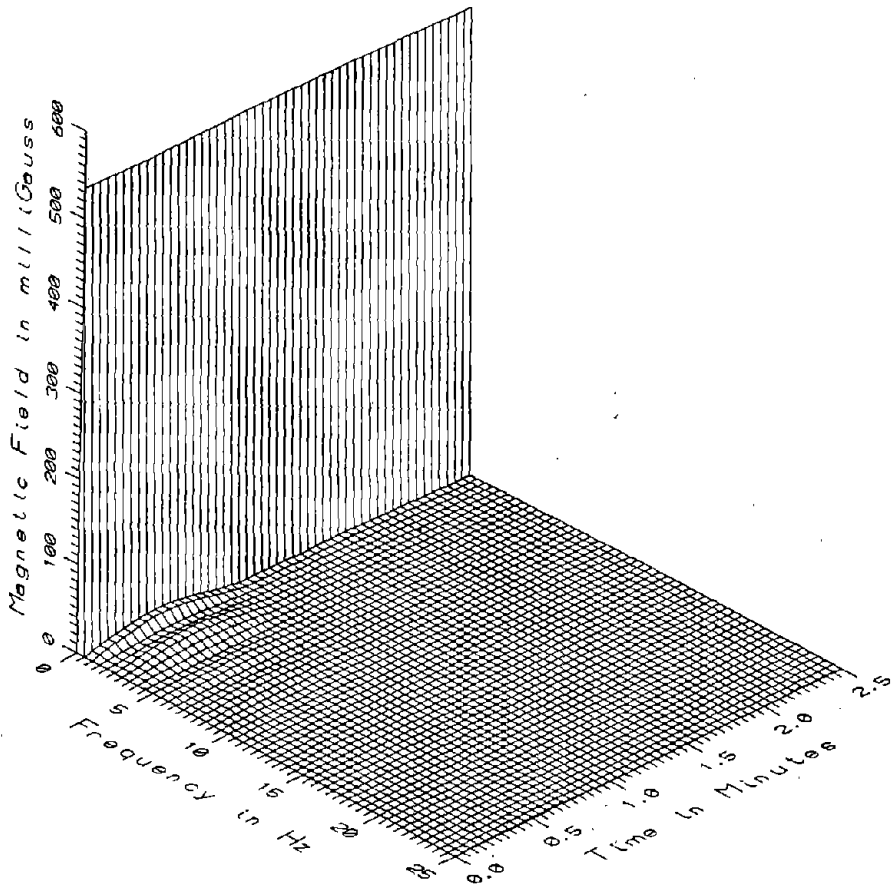

TR7012 - 3M WEST OF HIGH STEEL GUIDEWAY, 25M NORTH OF PROFILE

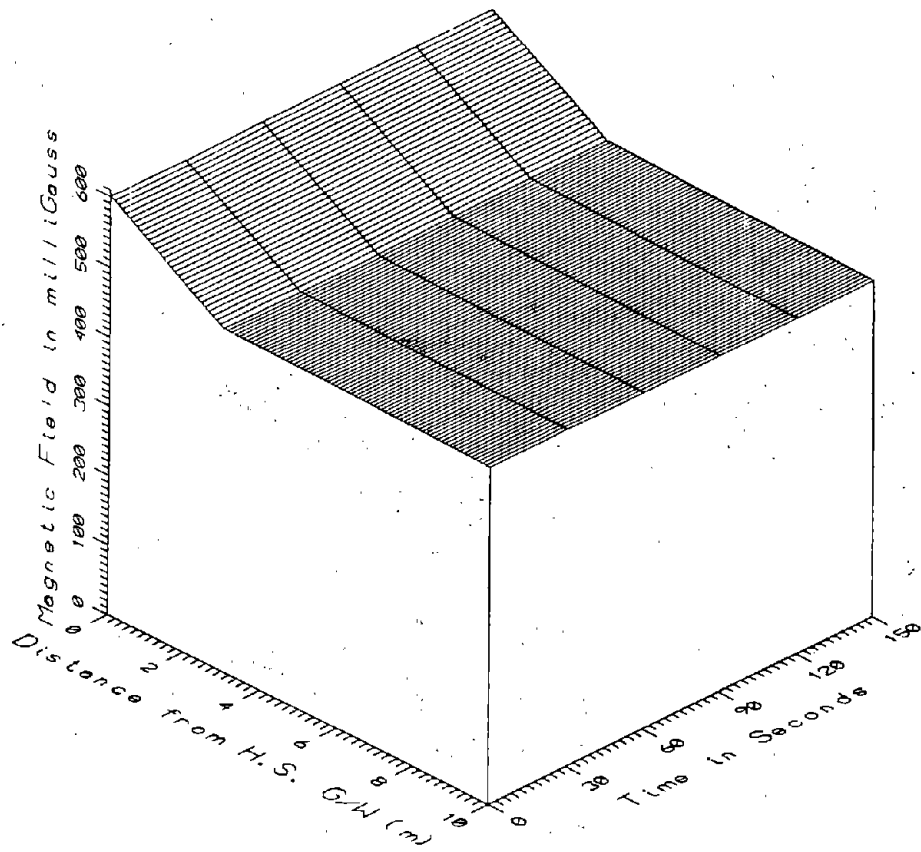

TR7012. HIGH STEEL GUIDEWAY - DC

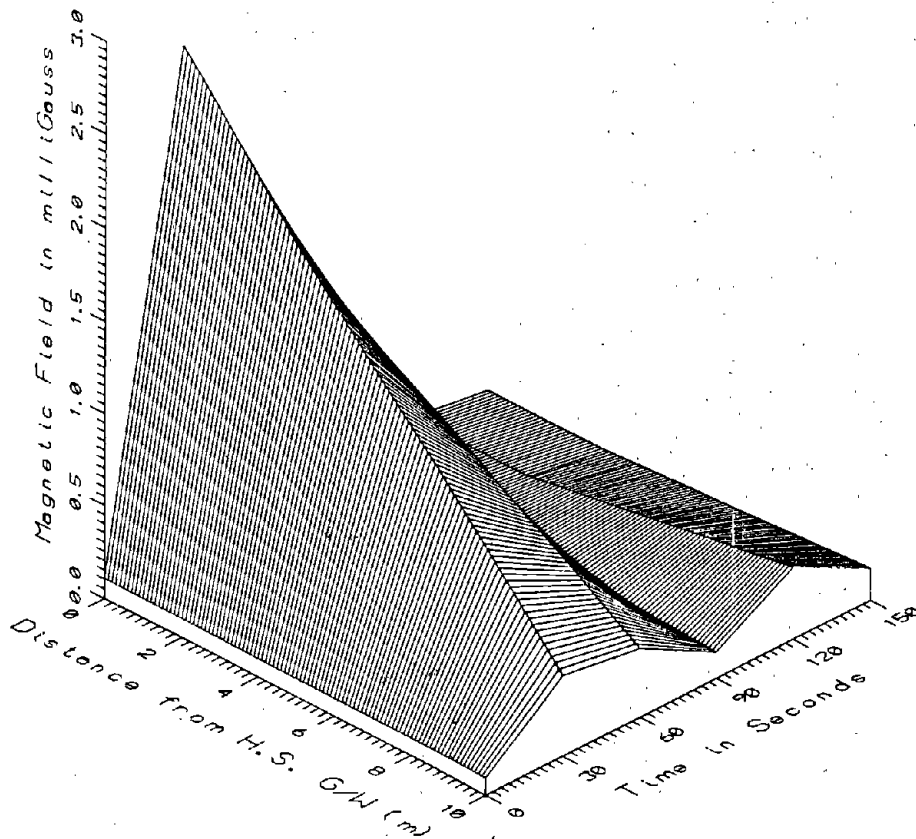

TR7012. HIGH STEEL GUIDEWAY - LOW FREQUENCY, 5-45Hz

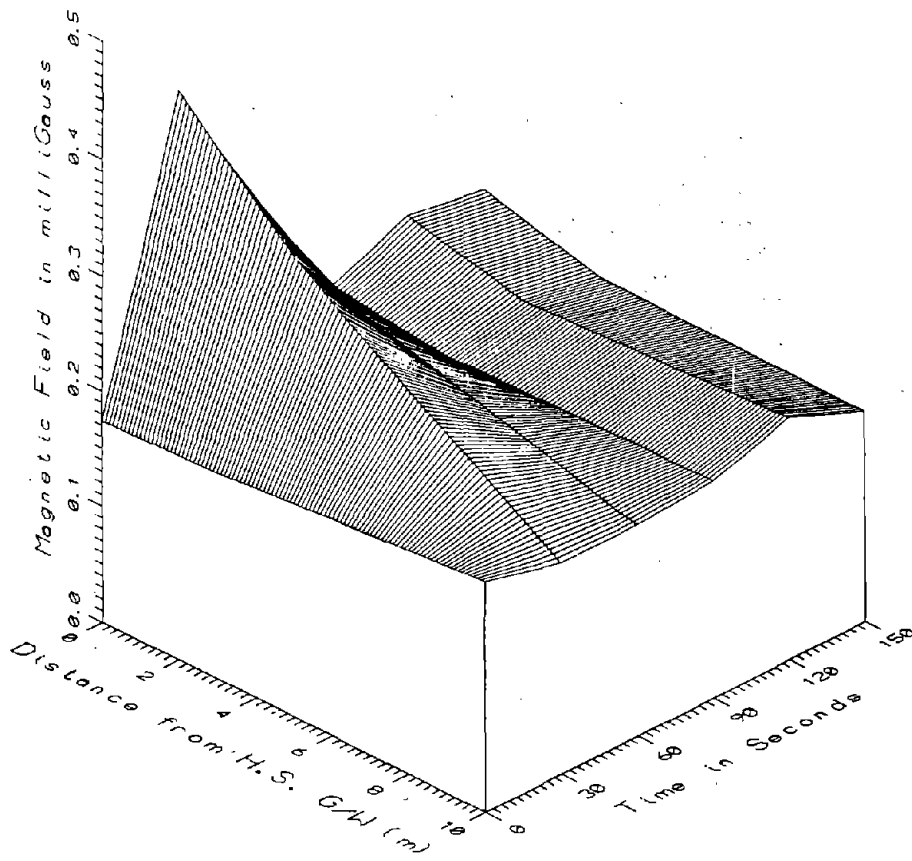

TR7012, HIGH STEEL GUIDEWAY - POWER FREQUENCY, 50-60Hz

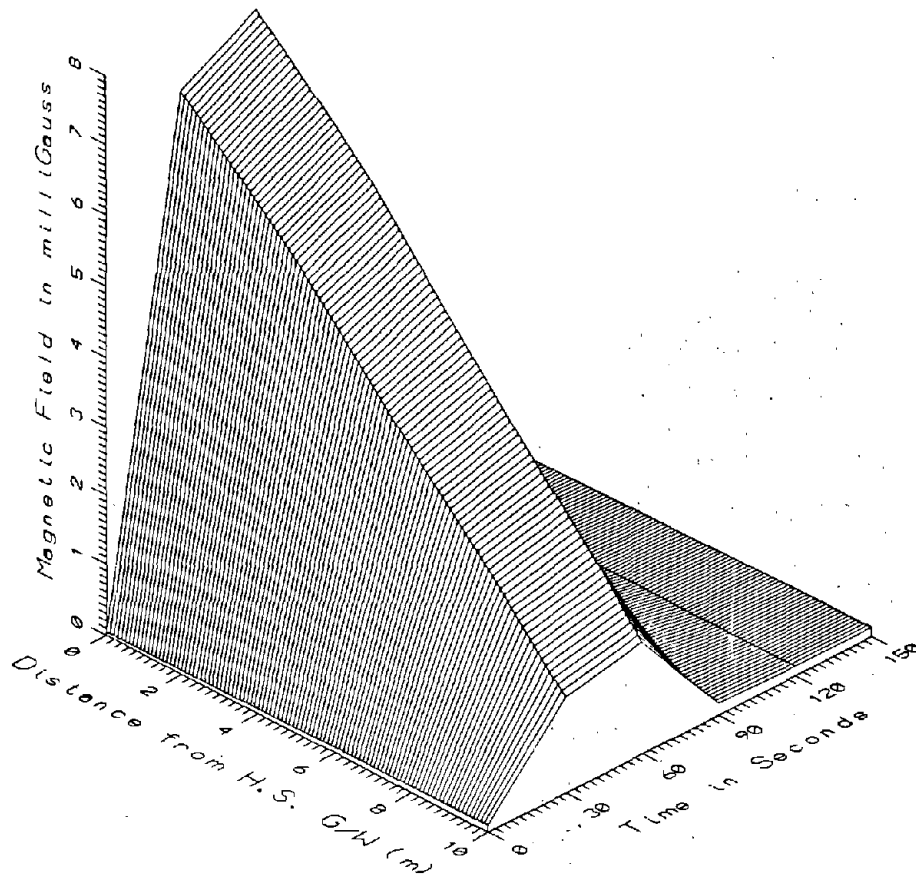

TR7012, HIGH STEEL GUIDEWAY - POWER HARMONICS, 65-300Hz

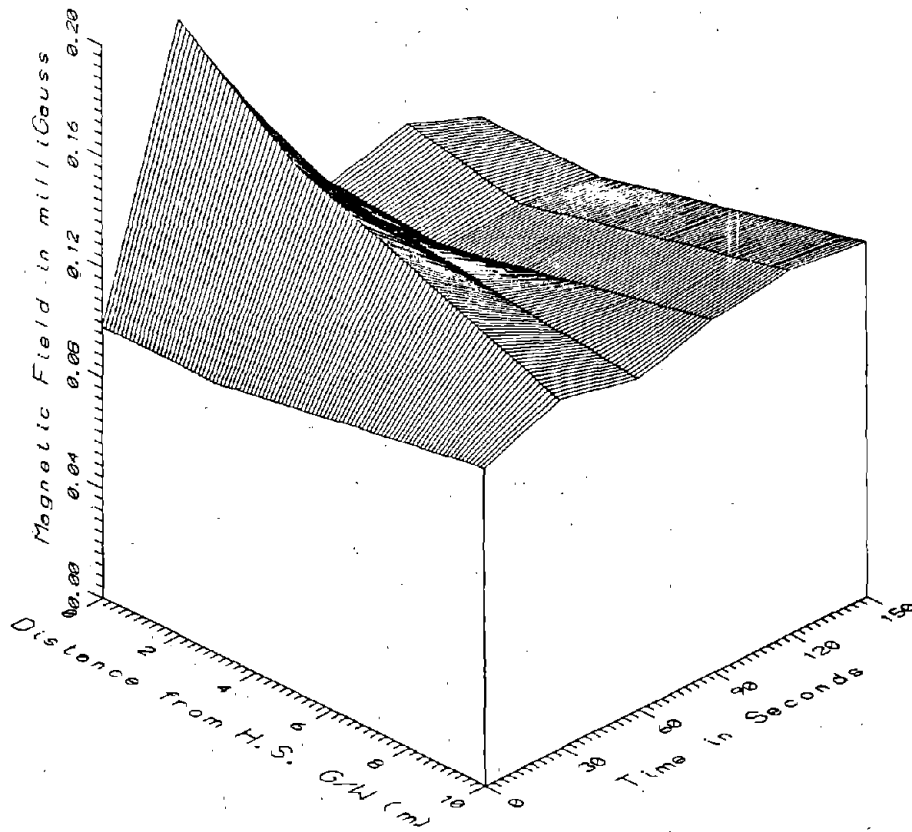

TR7012, HIGH STEEL GUIDEWAY - HIGH FREQUENCY, 305-2560Hz

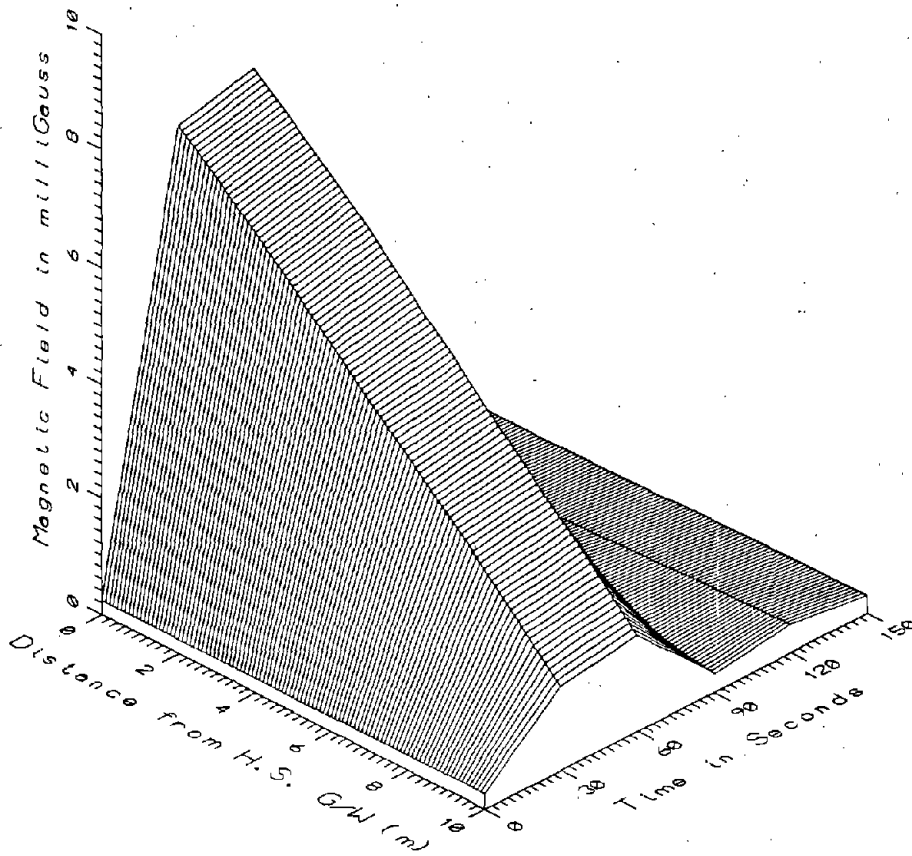

TR7012, HIGH STEEL GUIDEWAY - ALL FREQUENCIES, 5-2560Hz

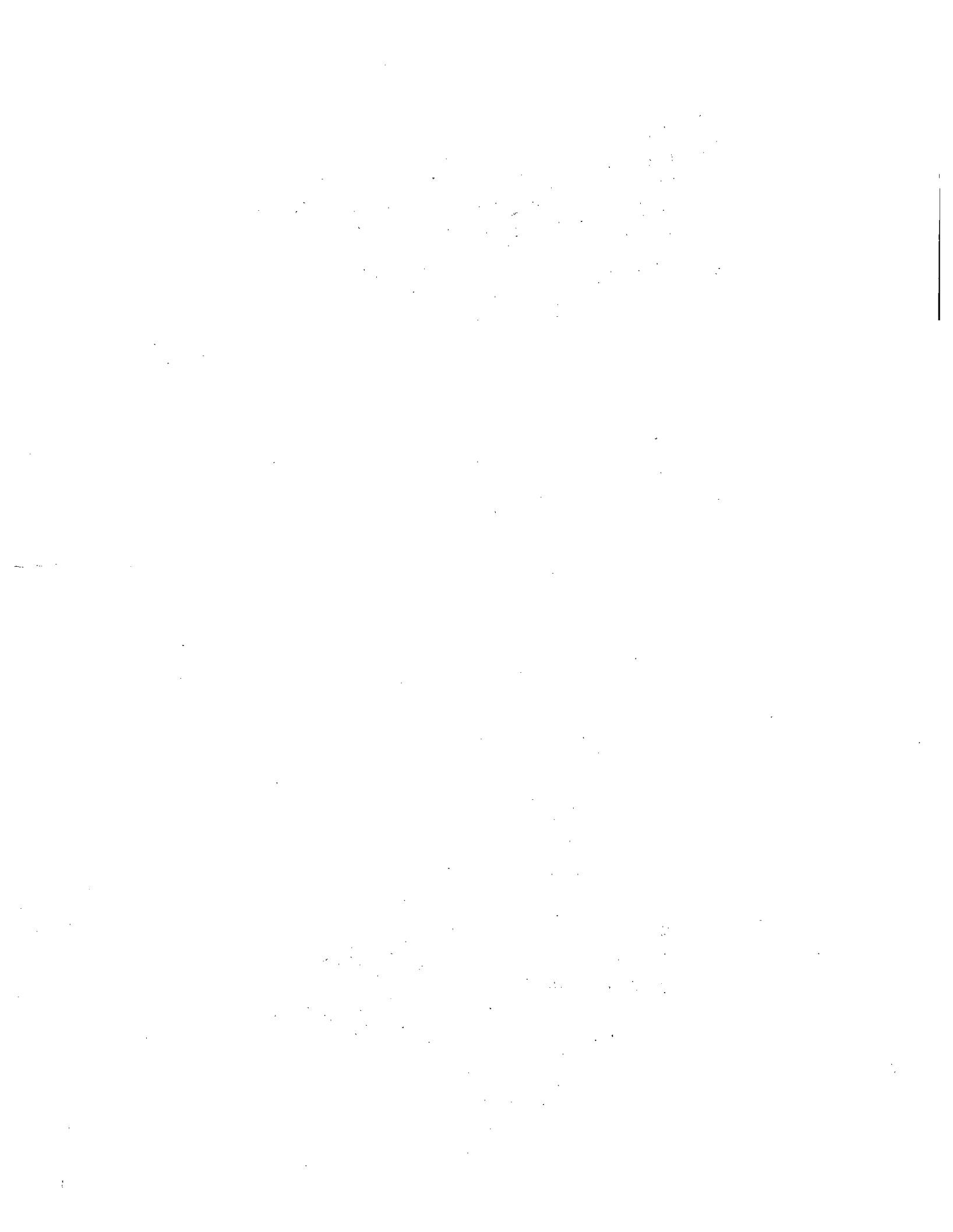

J-1

APPENDIX J
DATA SET TR7013
LATERAL PROFILE
BENEATH THE HIGH STEEL GUIDEWAY

J-1

APPENDIX J

DATA SET TR7013
LATERAL PROFILE BENEATH THE HIGH STEEL GUIDEWAY

Measurement Setup Code: 18
Vehicle Status: Running continuously
Measurement Date: August 8, 1990
Measurement Time: Start: 10:50:00
End: 11:12:00
Number of Samples: 221
Programmed Sample Interval: 3 sec
Actual Sample Interval: 6 sec

Frequency Spectrum Parameters

<u>Probe Type:</u>	<u>Coil (AC)</u>	<u>Fluxgate (DC)</u>
Maximum Frequency (Hz)	2560	256
Minimum Frequency (Hz)	5	0
Spectral Bandwidth (Hz)	5	0.5

Missing or Suspect Data: None

SETUP 18, 19: HIGH STEEL GUIDEWAY, PILLAR 2423 NEAR CONTROL CENTER

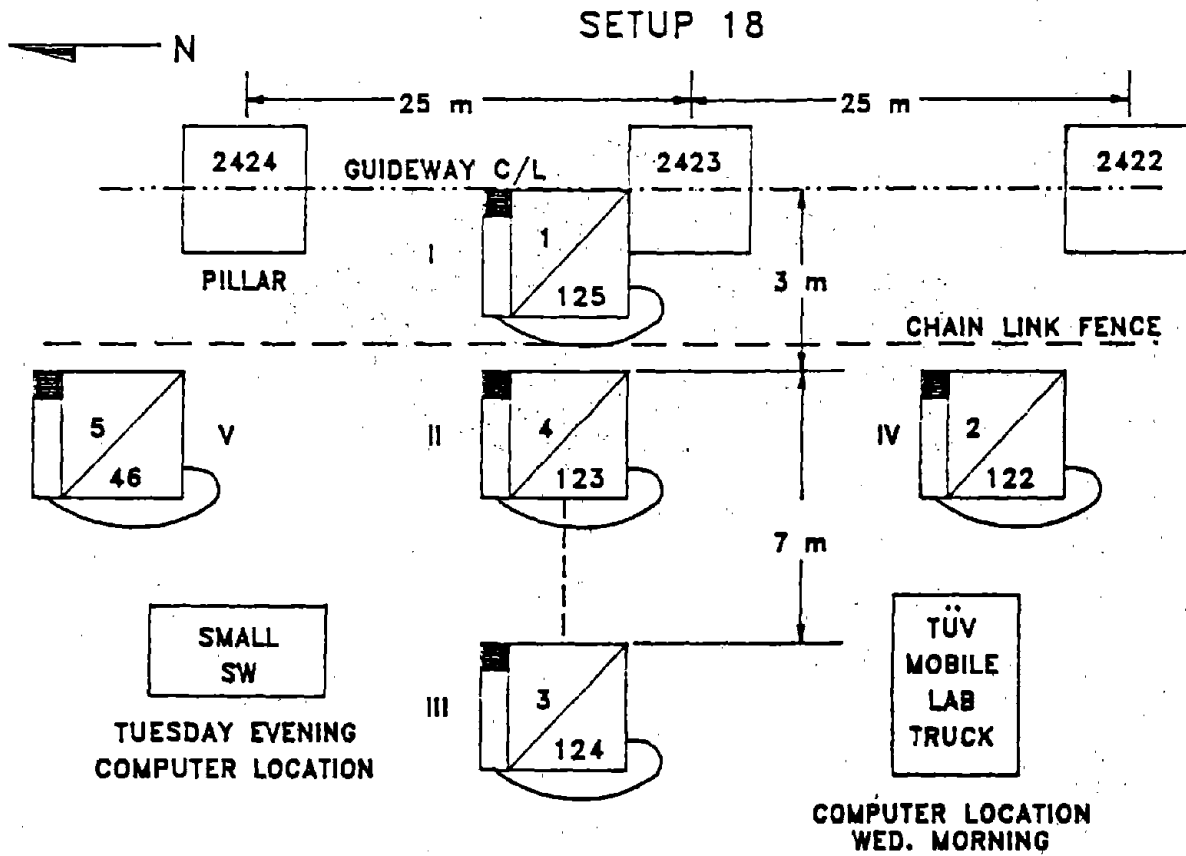

TOP VIEW OF ALL PROBE ORIENTATIONS

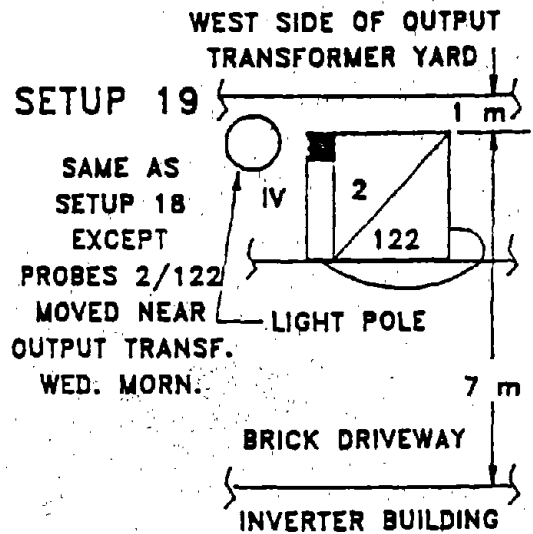
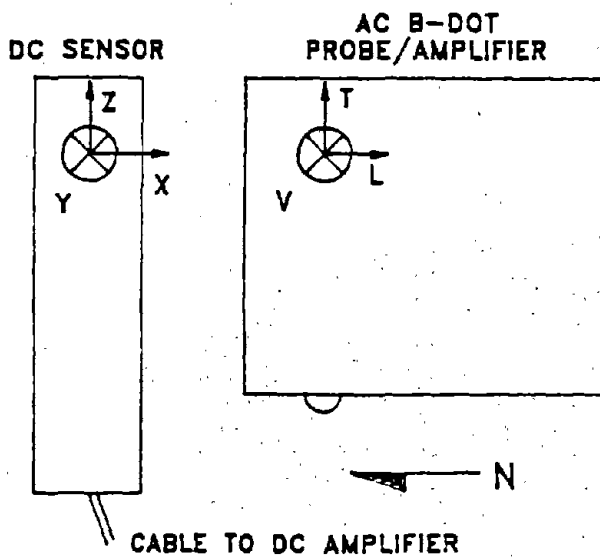

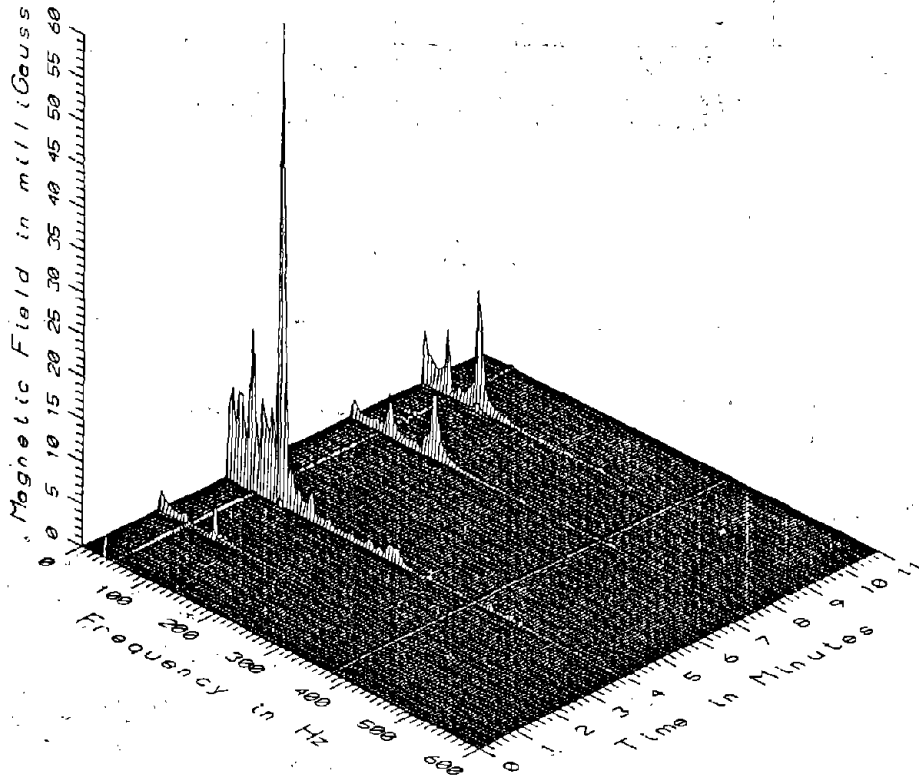

TR7013 - UNDER CENTER OF HIGH STEEL GUIDEWAY

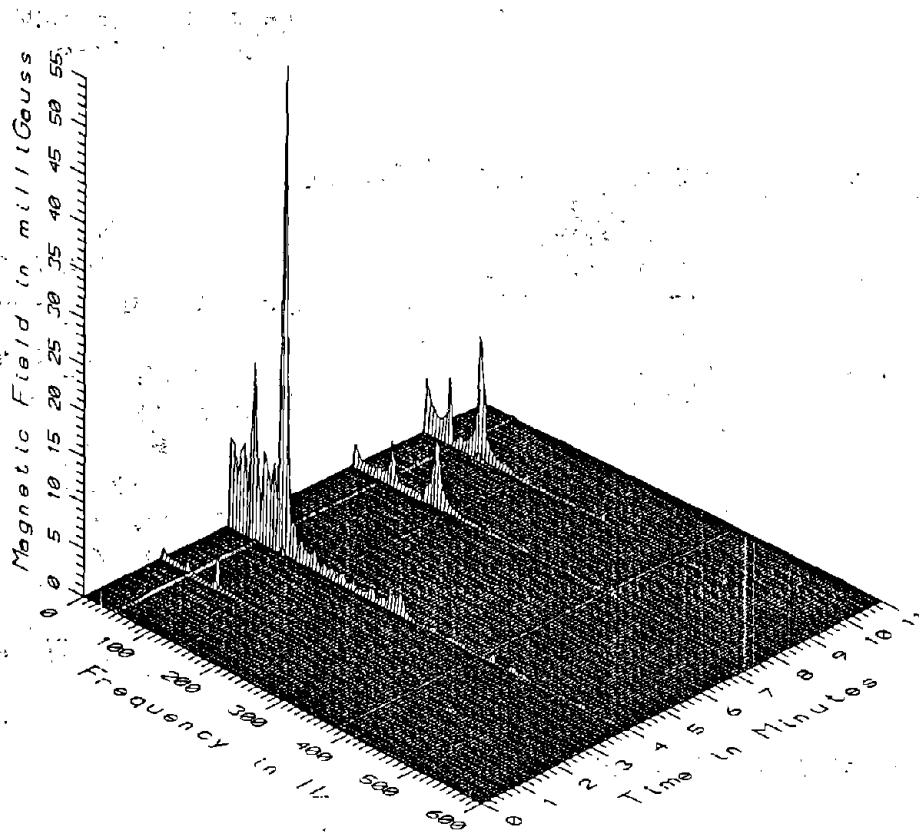

TR7013 - 311 WEST OF HIGH STEEL GUIDEWAY

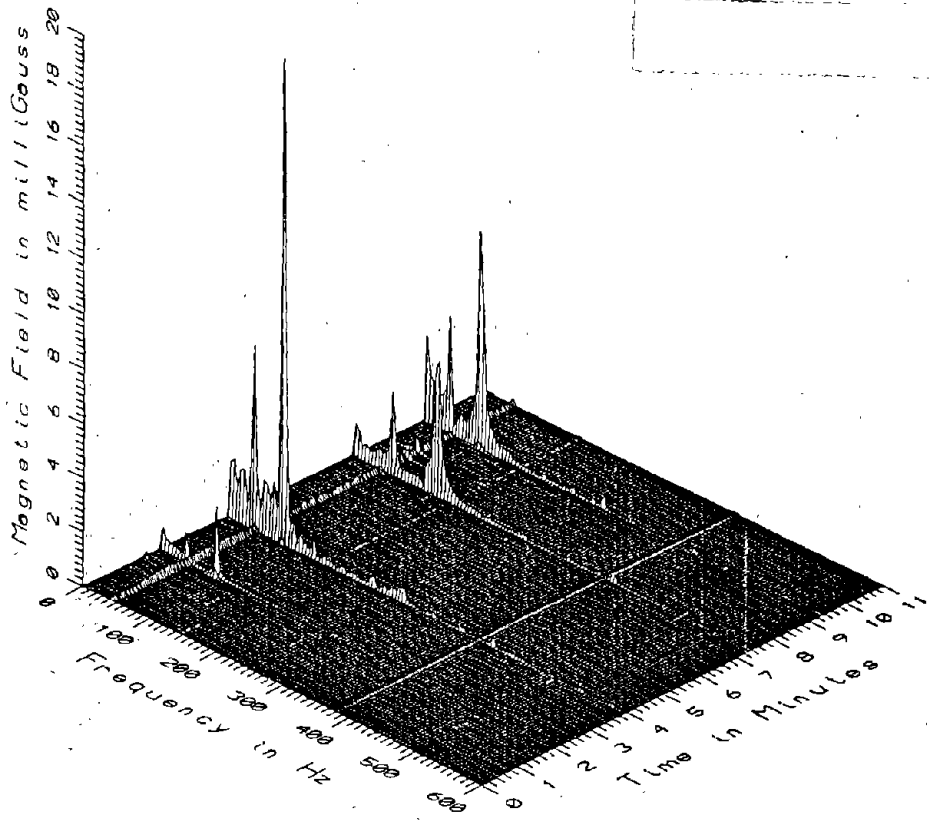

TR7013 - 10M WEST OF HIGH STEEL GUIDEWAY

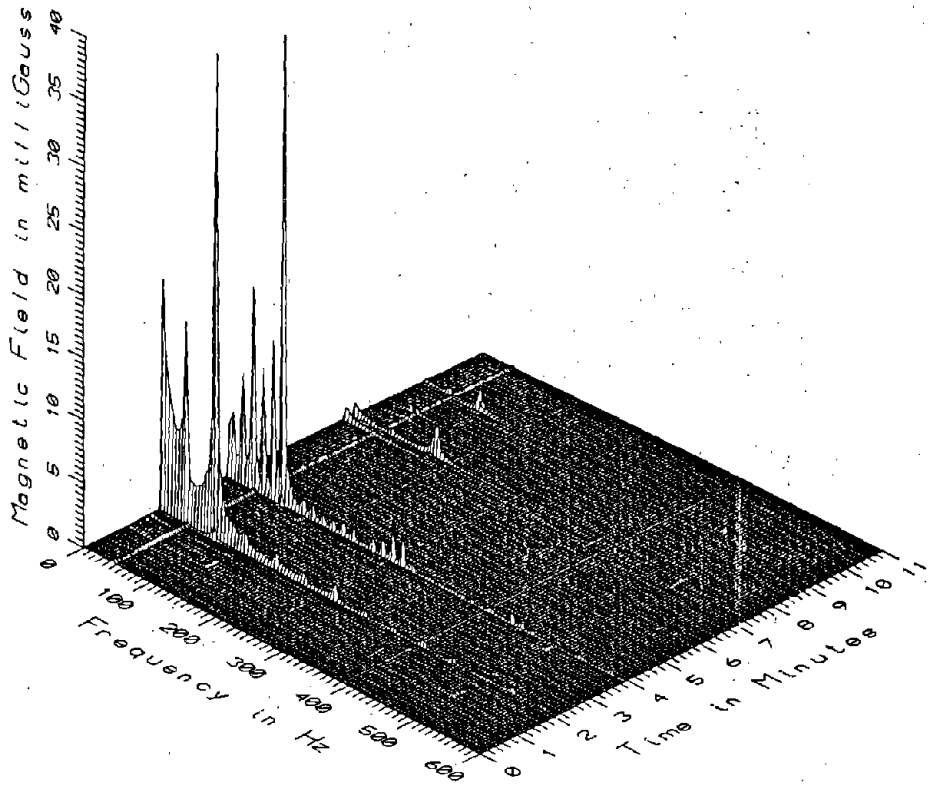

TR7013 - 3M WEST OF HIGH STEEL GUIDEWAY, 25M SOUTH OF PROFILE

J-4

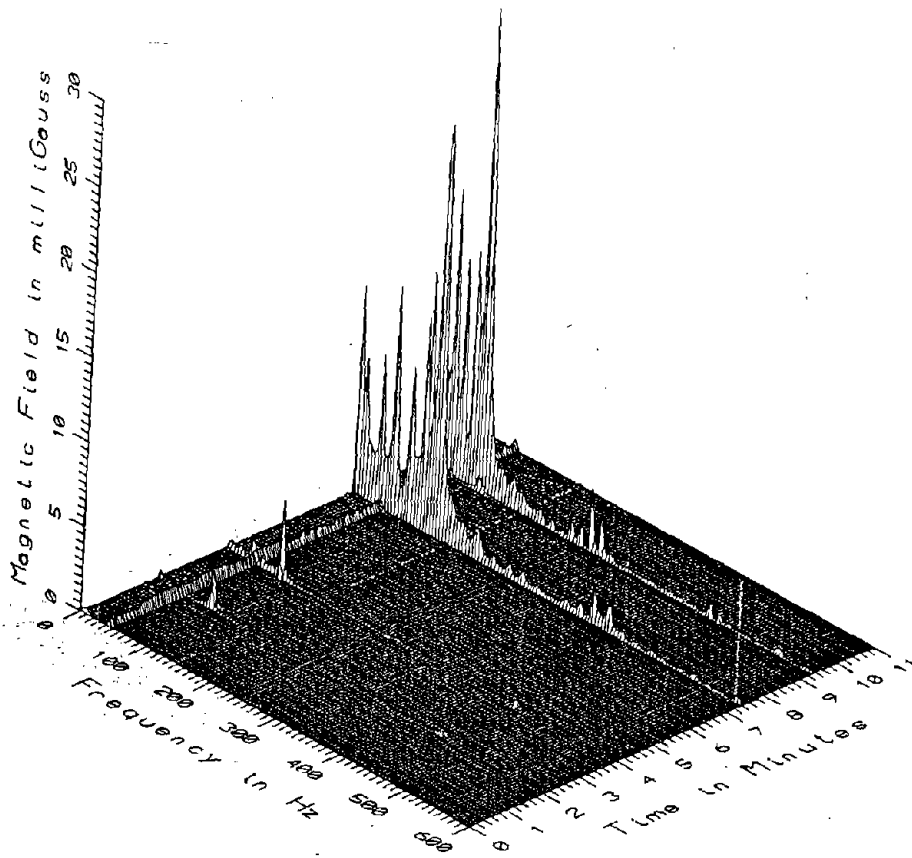

TR7013 - 3M WEST OF HIGH STEEL GUIDEWAY, 25M NORTH OF PROFILE

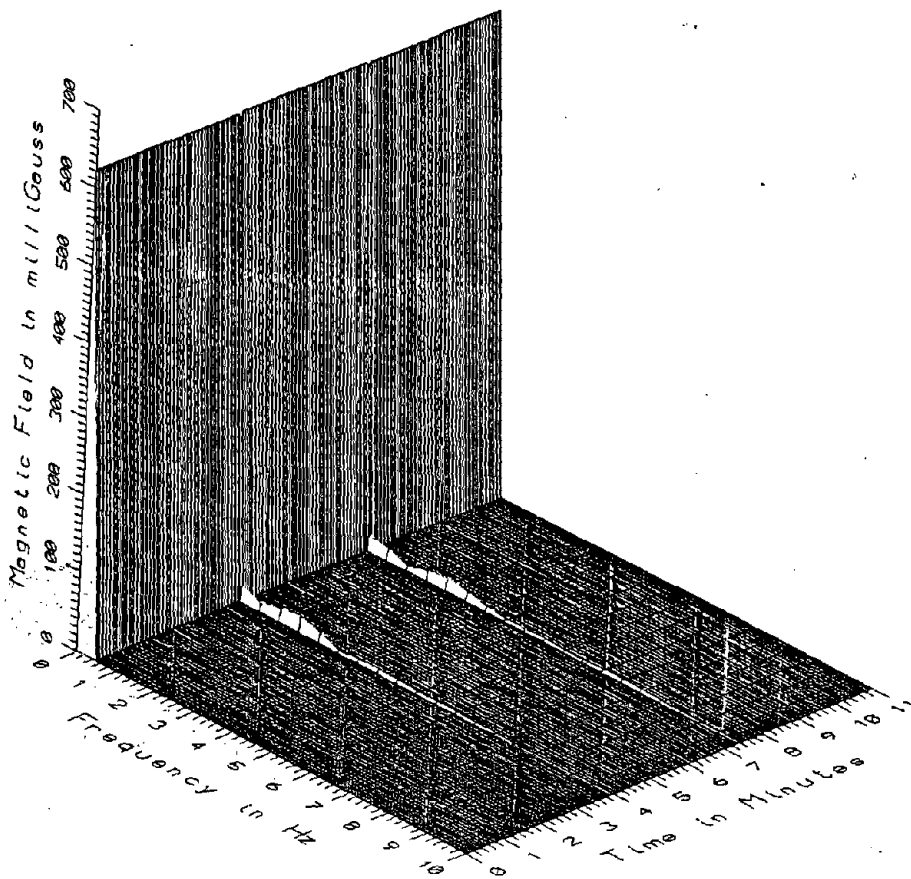

TR7013 - UNDER CENTER OF HIGH STEEL GUIDEWAY

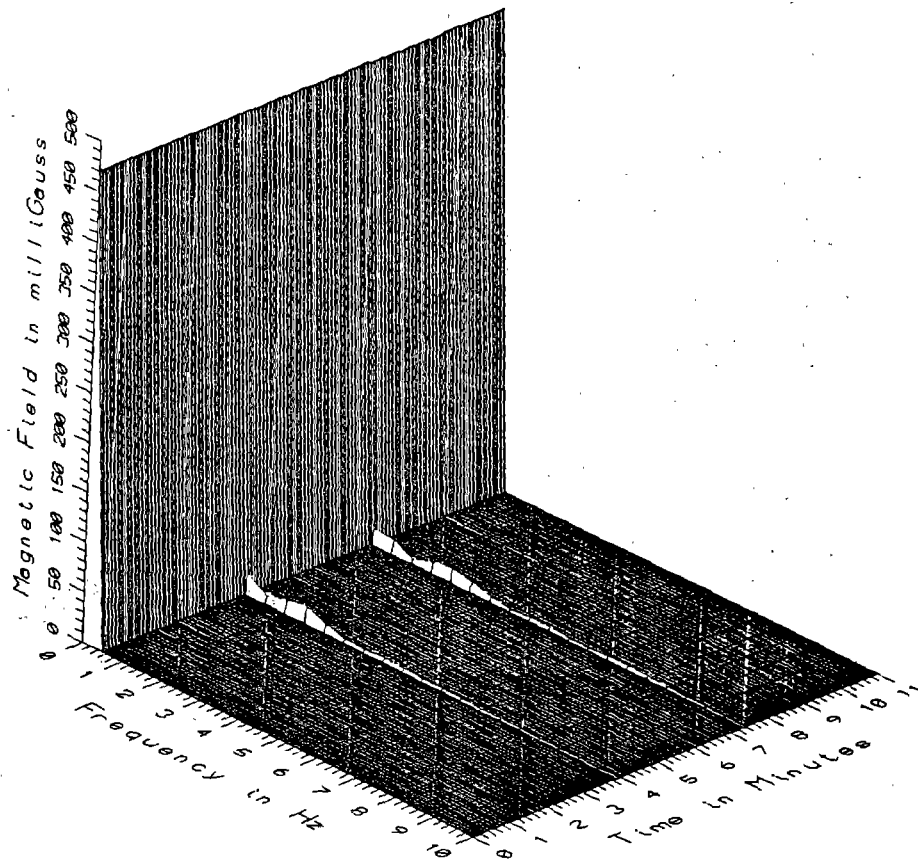

TR7013 - 3M WEST OF HIGH STEEL GUIDEWAY

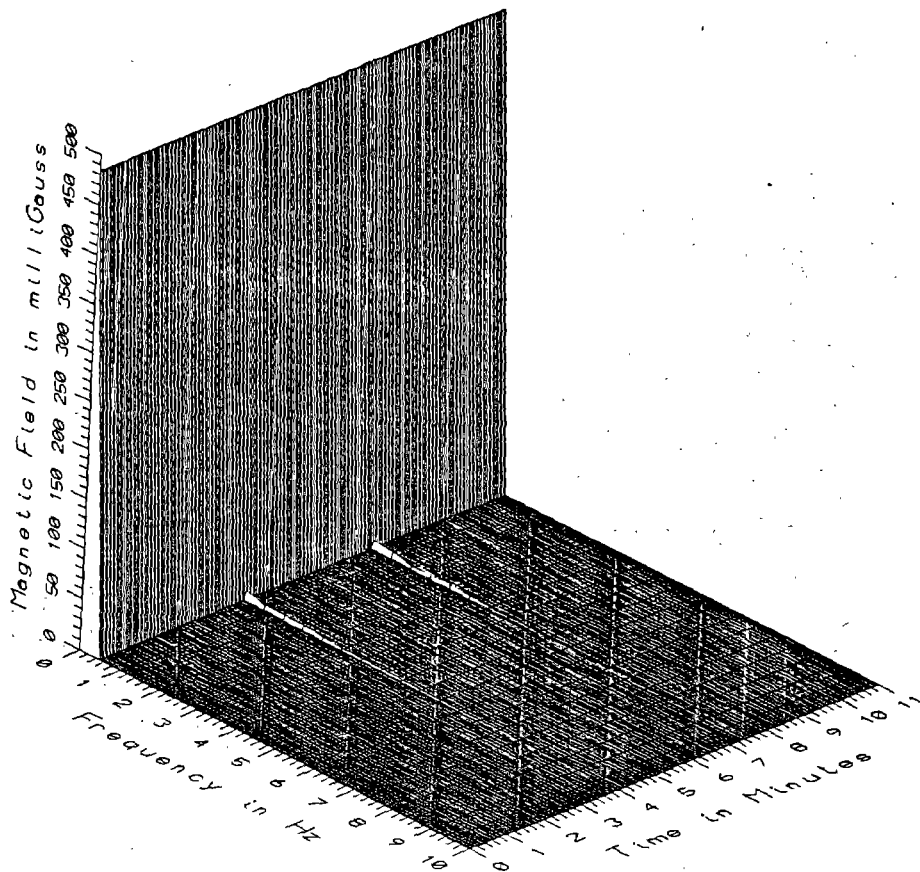

TR7013 - 10M WEST OF HIGH STEEL GUIDEWAY

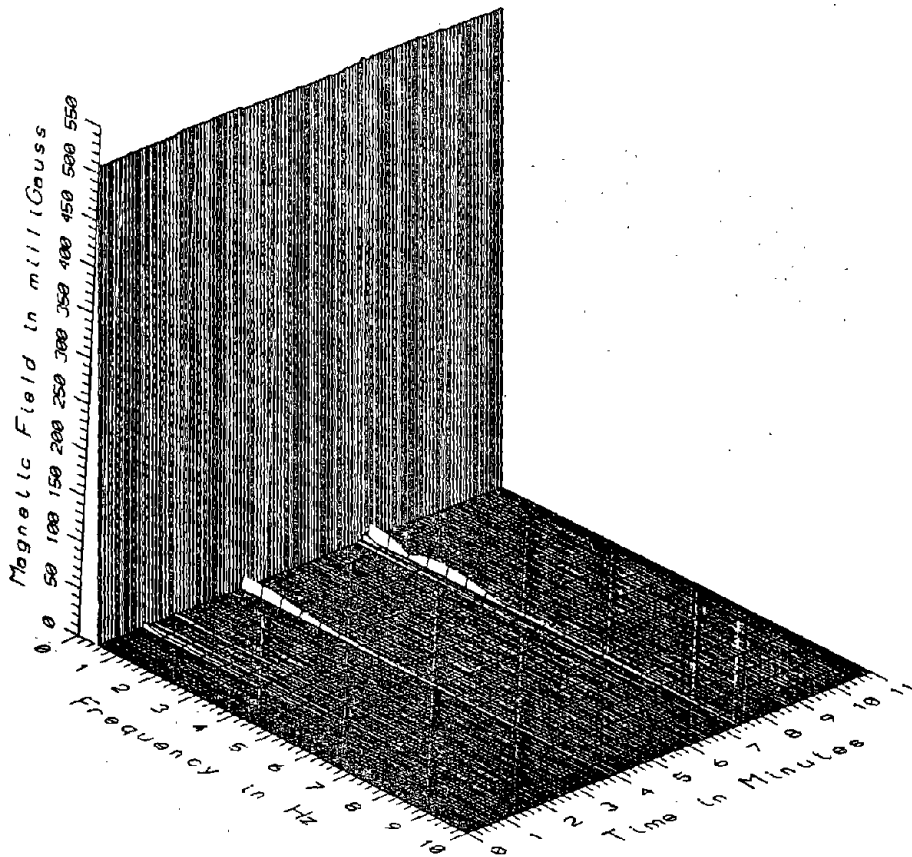

TR7013 - 3M WEST OF HIGH STEEL GUIDEWAY. 25M SOUTH OF PROFILE

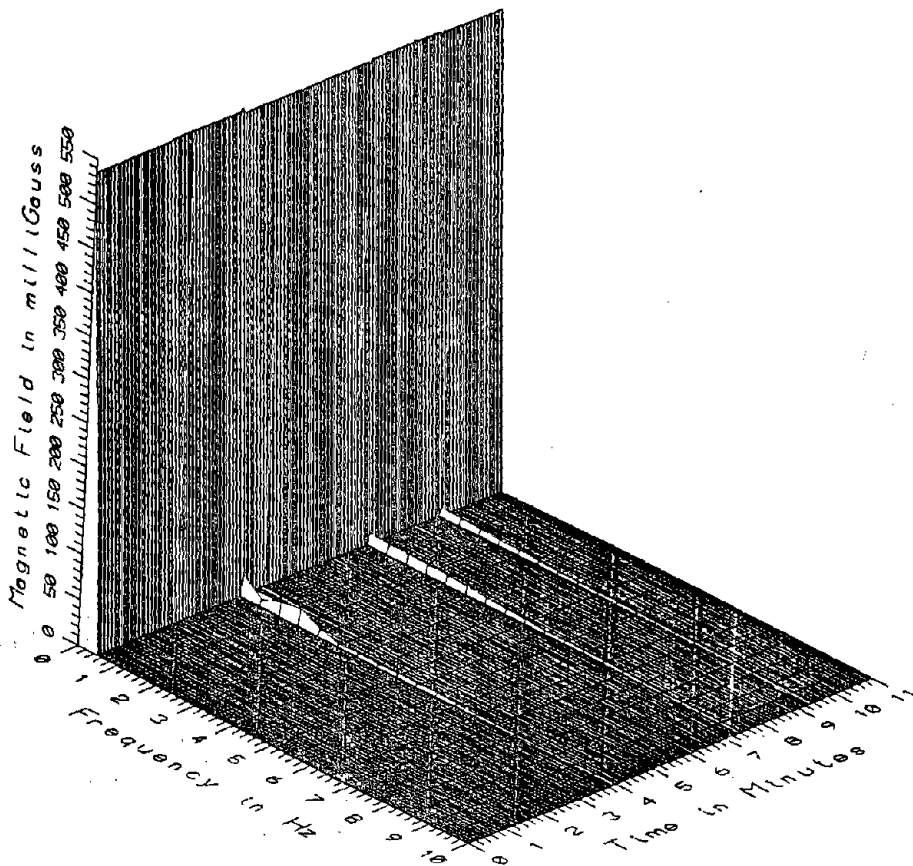

TR7013 - 3M WEST OF HIGH STEEL GUIDEWAY. 25M NORTH OF PROFILE

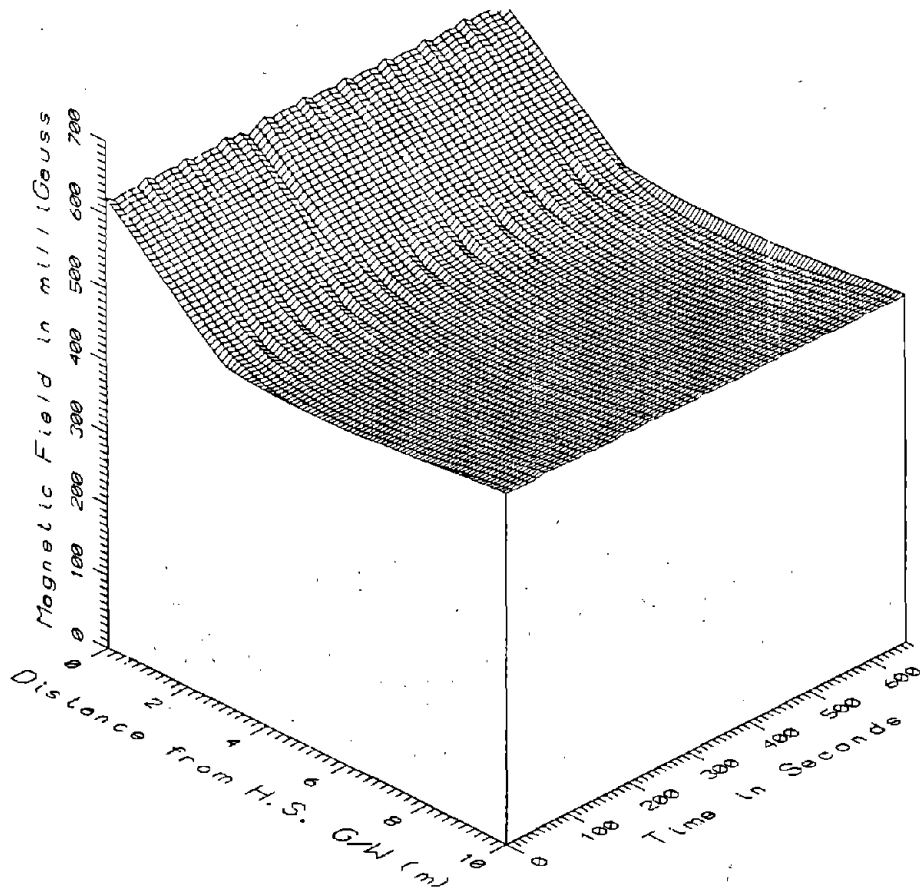

TR7013. HIGH STEEL GUIDEWAY - DC

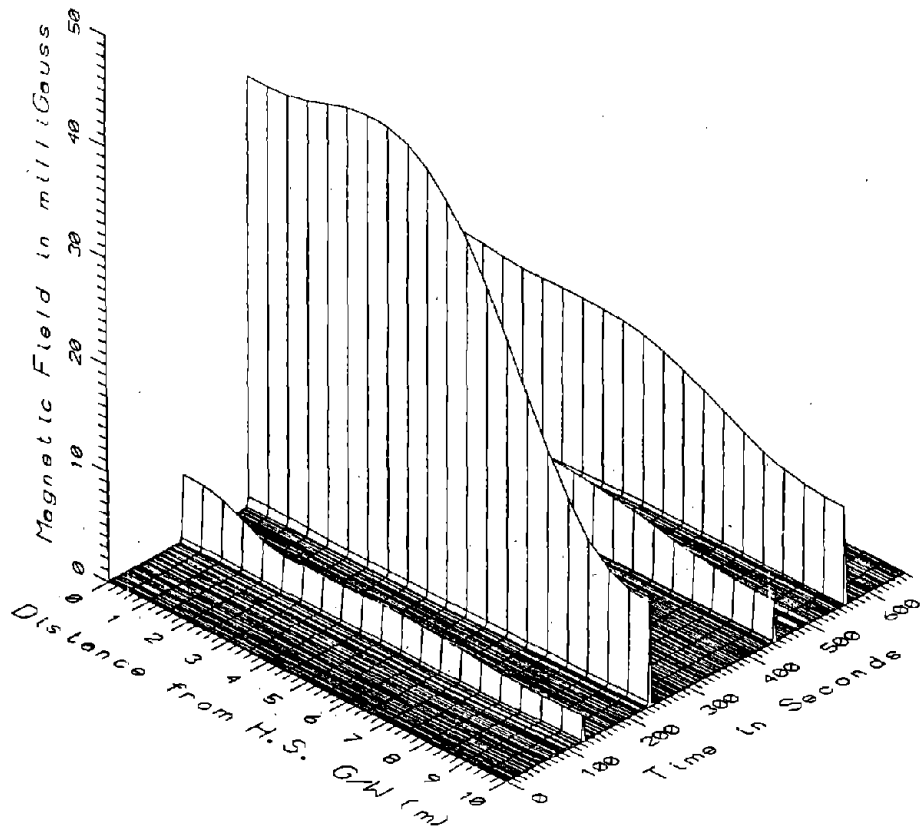

TR7013. HIGH STEEL GUIDEWAY - LOW FREQUENCY, 5-45Hz

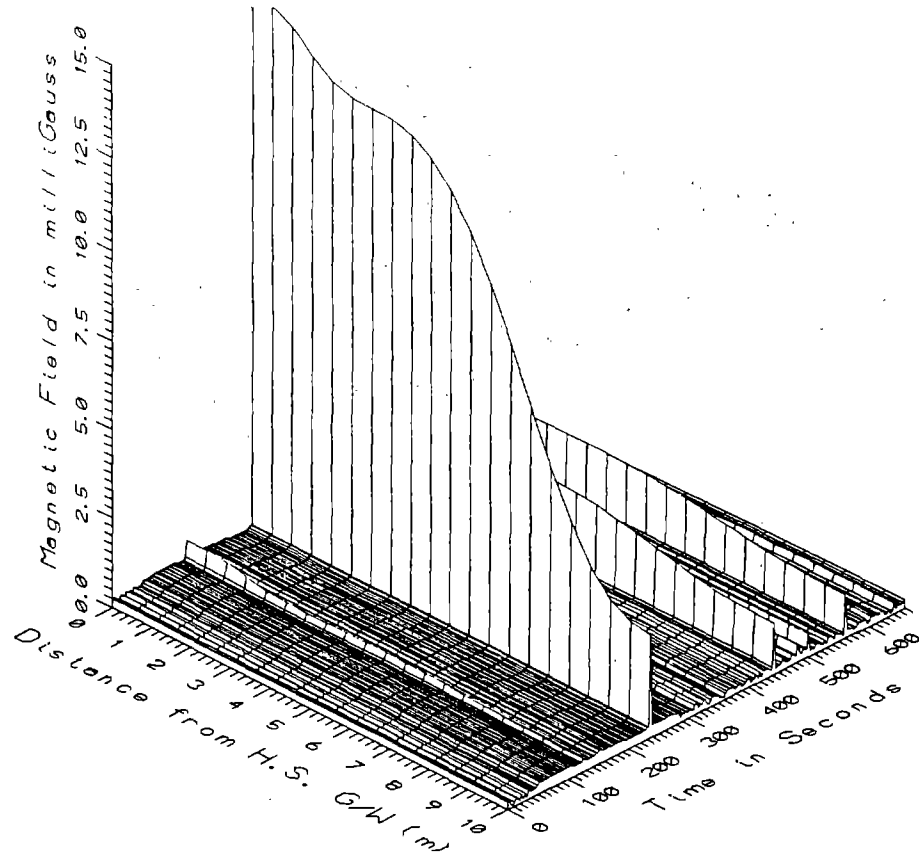

TR7013, HIGH STEEL GUIDEWAY - POWER FREQUENCY, 50-60Hz

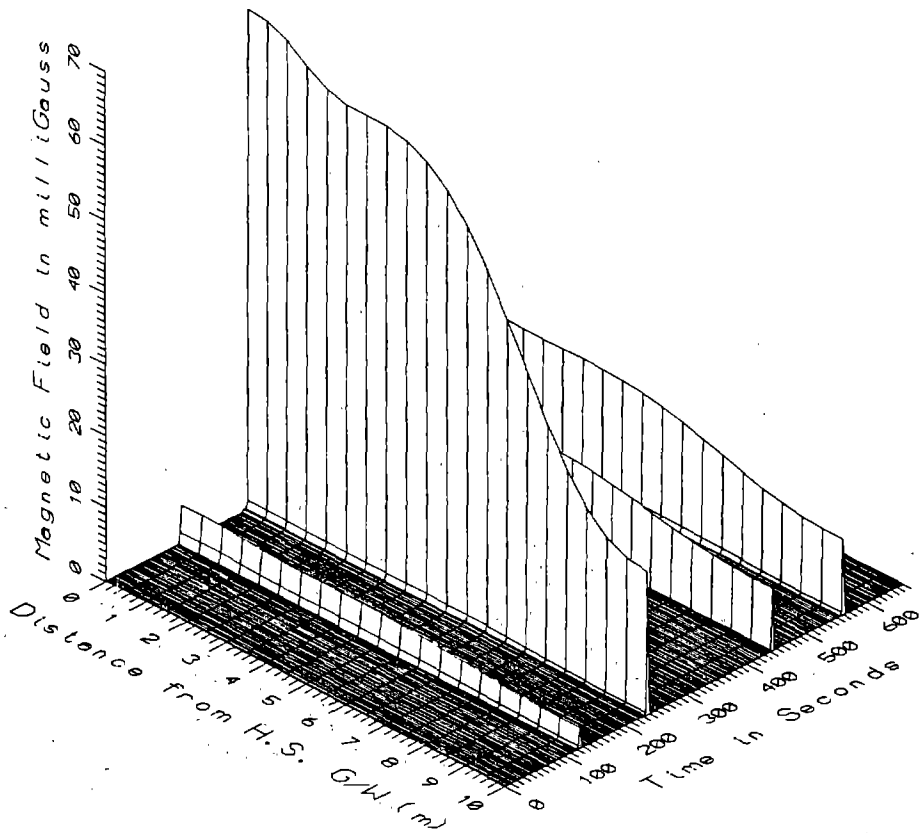

TR7013, HIGH STEEL GUIDEWAY - POWER HARMONICS, 65-300Hz

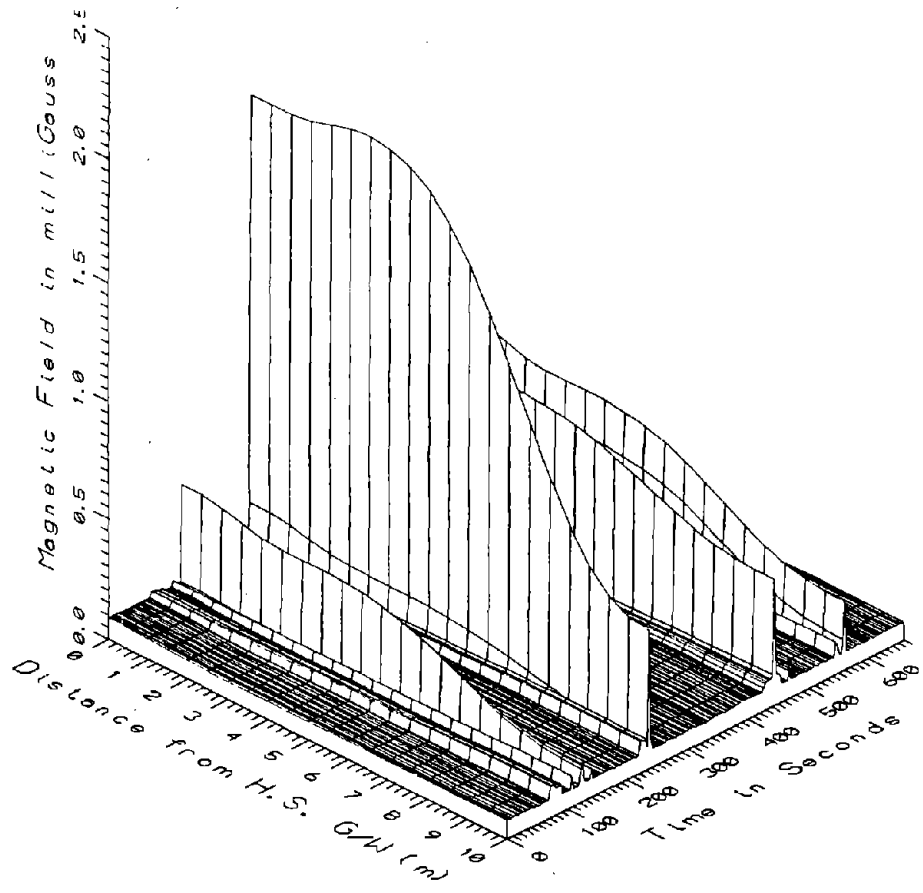

TR7013, HIGH STEEL GUIDEWAY - HIGH FREQUENCY, 305-2560Hz

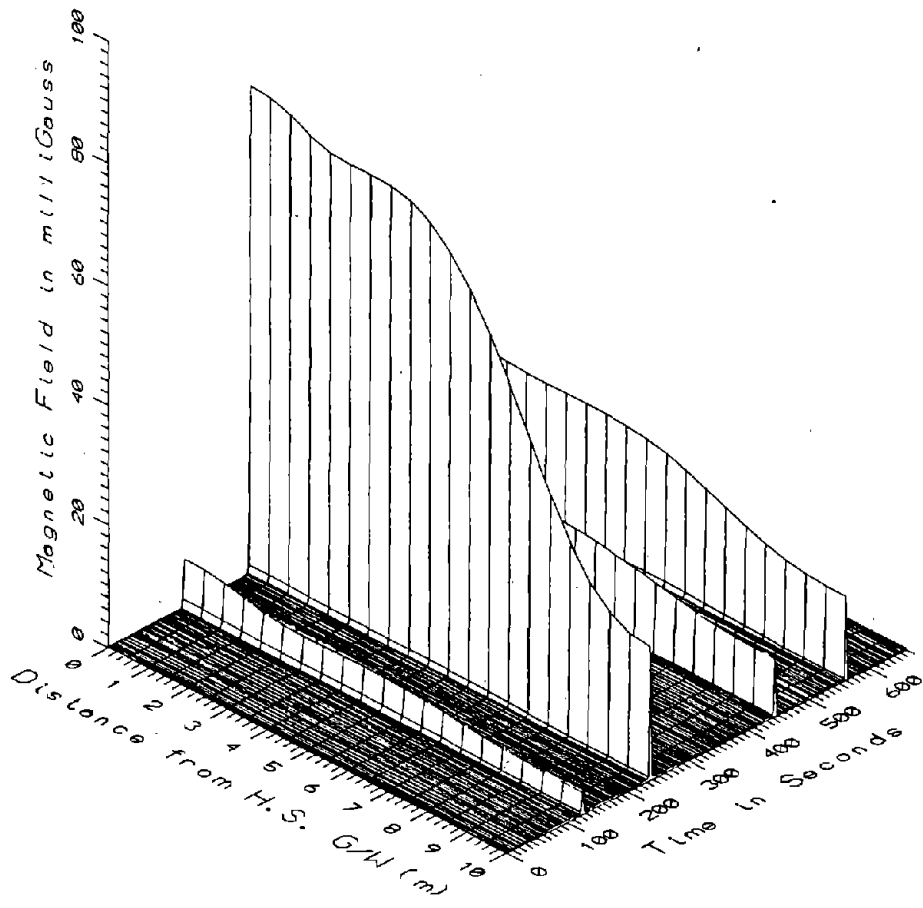

TR7013, HIGH STEEL GUIDEWAY - ALL FREQUENCIES, 5-2560Hz

J-10

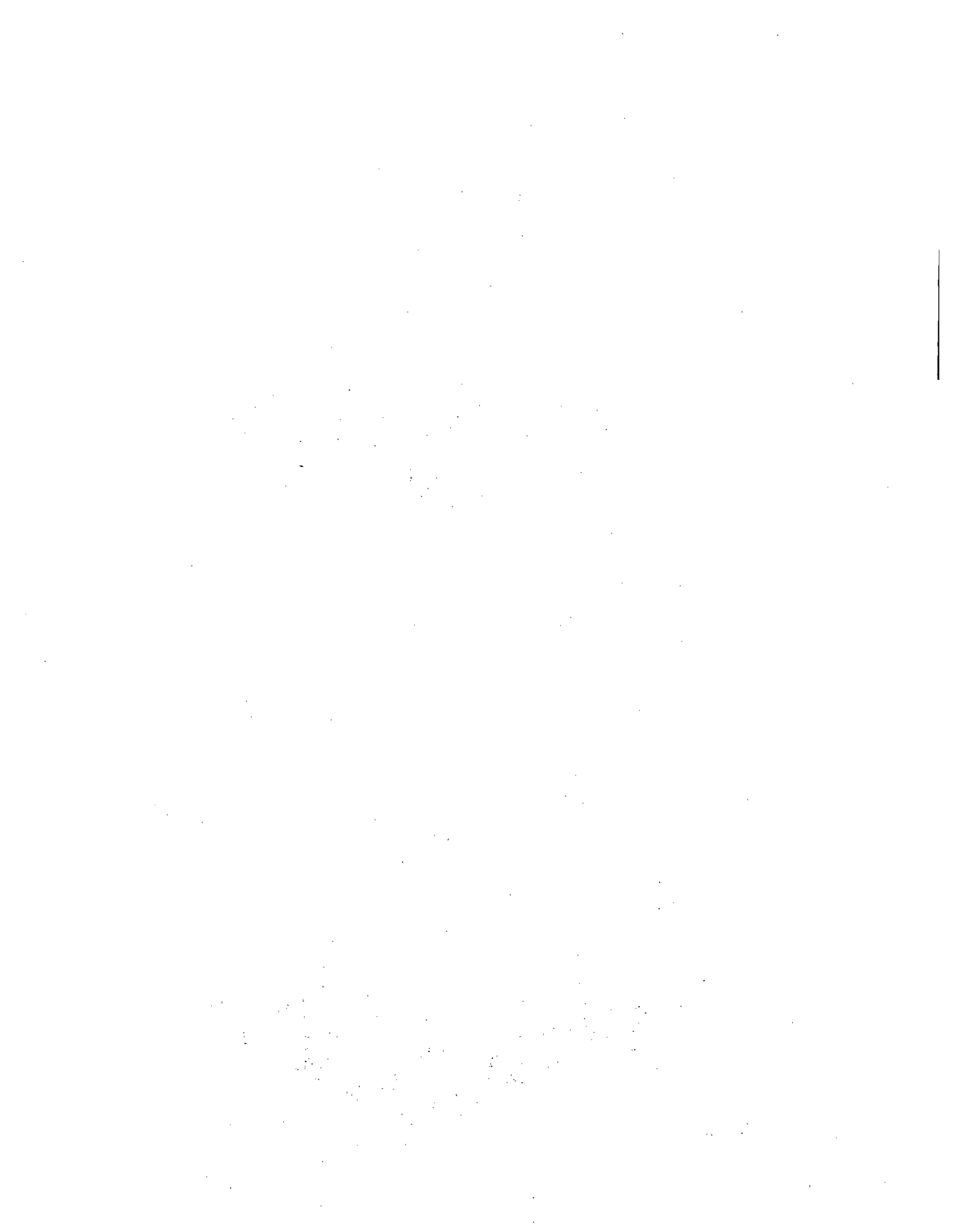

K-1

APPENDIX K
DATA SET TR7014
LATERAL PROFILE
BENEATH THE HIGH STEEL GUIDEWAY

k-1

APPENDIX K

DATA SET TR7014
LATERAL PROFILE BENEATH THE HIGH STEEL GUIDEWAY

Measurement Setup Code: 18
Vehicle Status: Running continuously
Measurement Date: August 8, 1990
Measurement Time: Start: 12:26:00
End: 12:37:30
Number of Samples: 116
Programmed Sample Interval: 3 sec
Actual Sample Interval: 6 sec

Frequency Spectrum Parameters

<u>Probe Type:</u>	<u>Coil (AC)</u>	<u>Fluxgate (DC)</u>
Maximum Frequency (Hz)	2560	256
Minimum Frequency (Hz)	5	0
Spectral Bandwidth (Hz)	5	0.5

Missing or Suspect Data: None

SETUP 18, 19: HIGH STEEL GUIDEWAY, PILLAR 2423 NEAR CONTROL CENTER

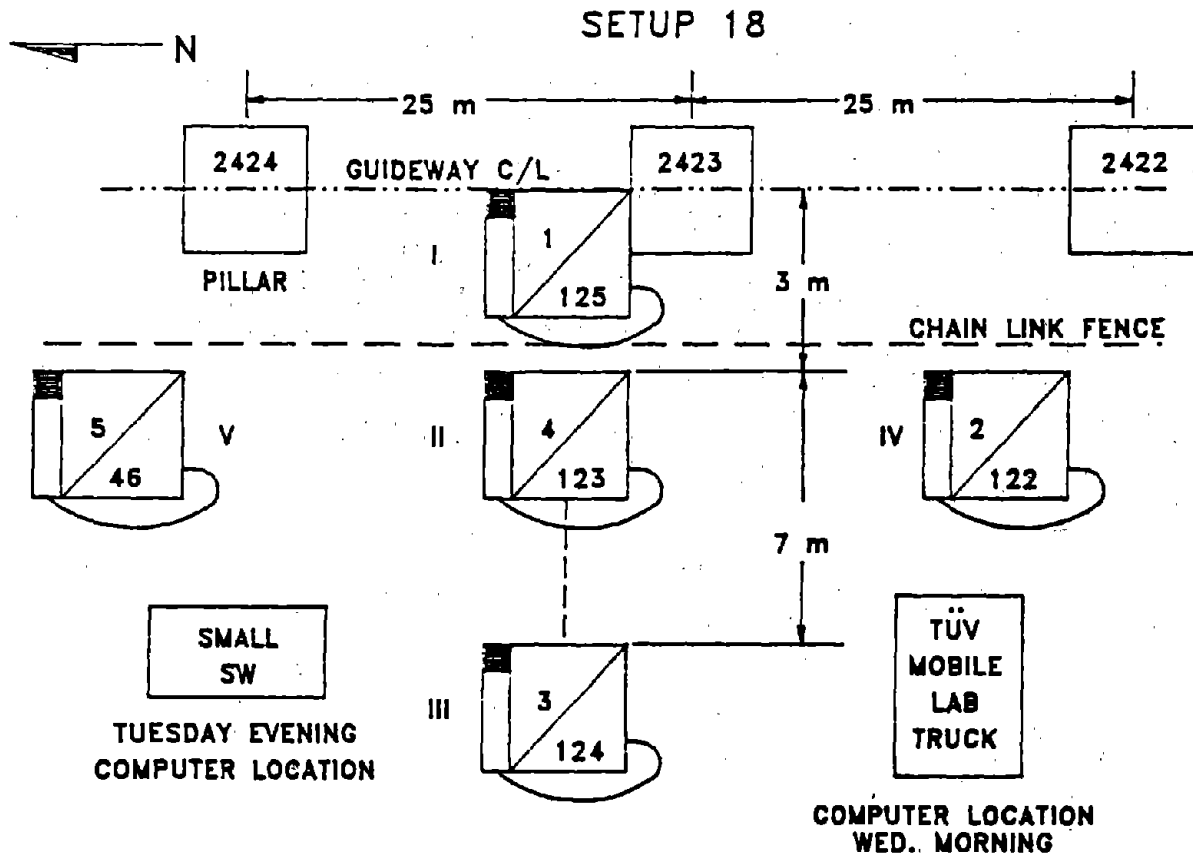

TOP VIEW OF ALL PROBE ORIENTATIONS

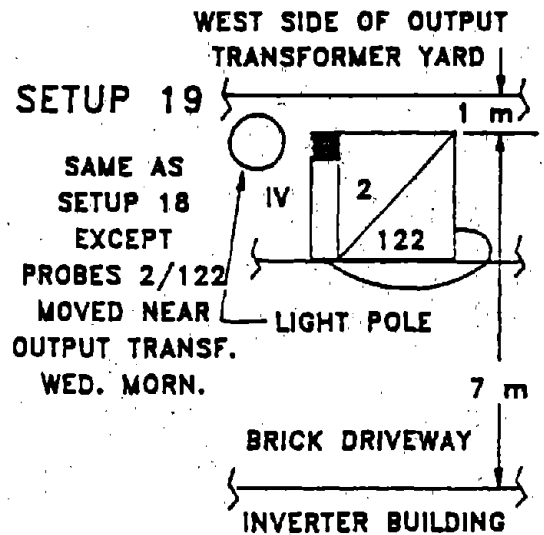
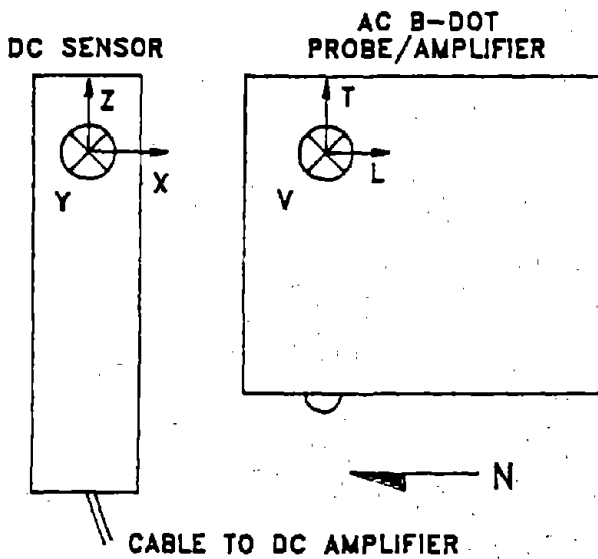

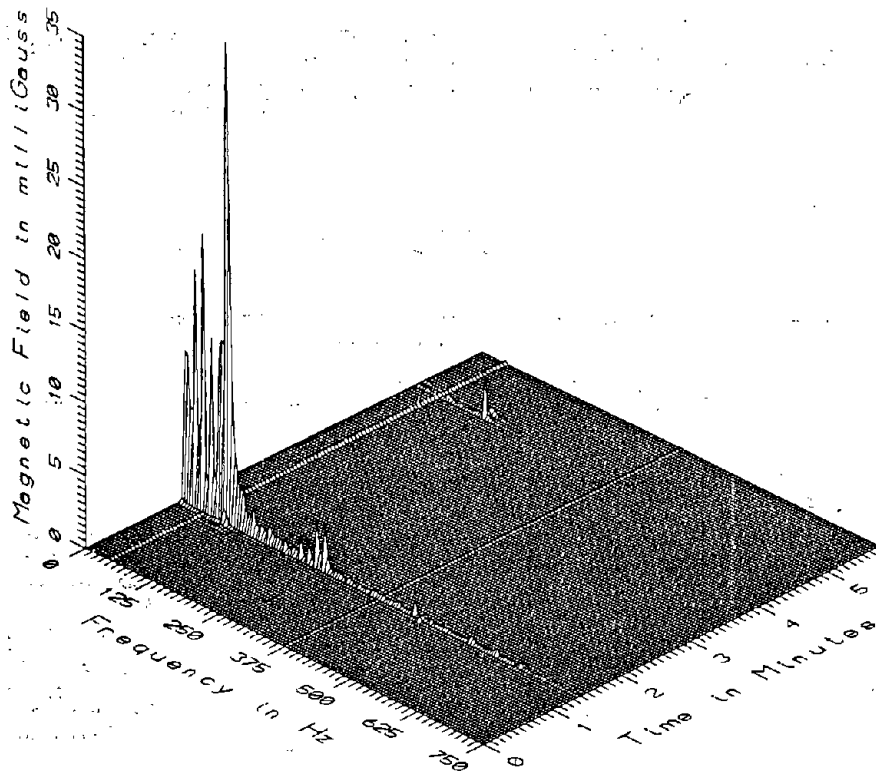

TR7014 - UNDER CENTER OF HIGH STEEL GUIDEWAY

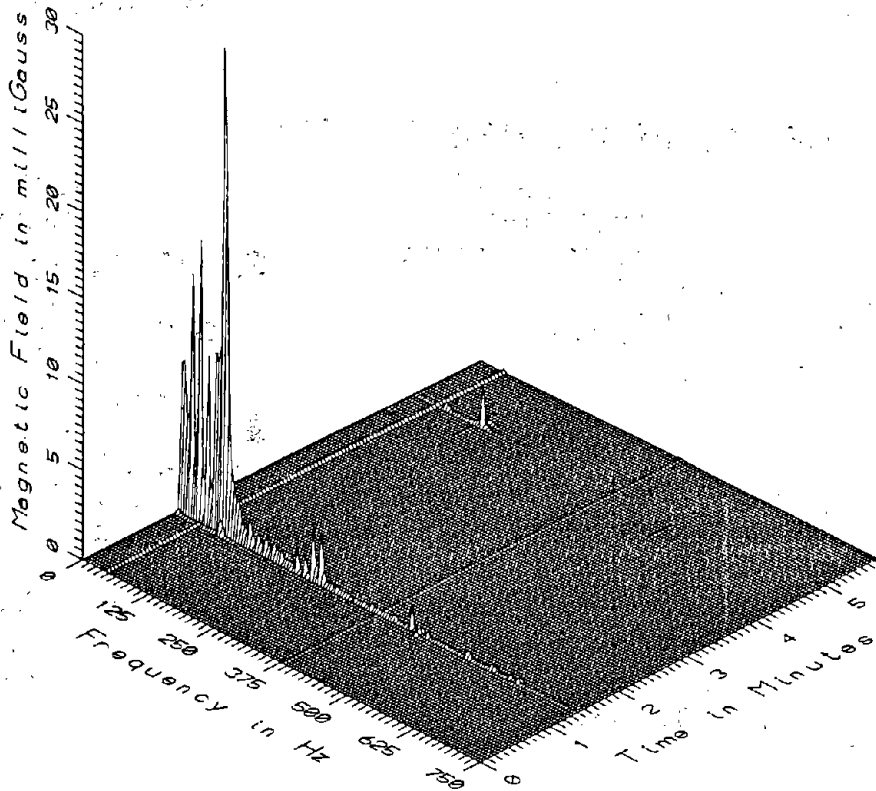

TR7014 - 3M WEST OF HIGH STEEL GUIDEWAY

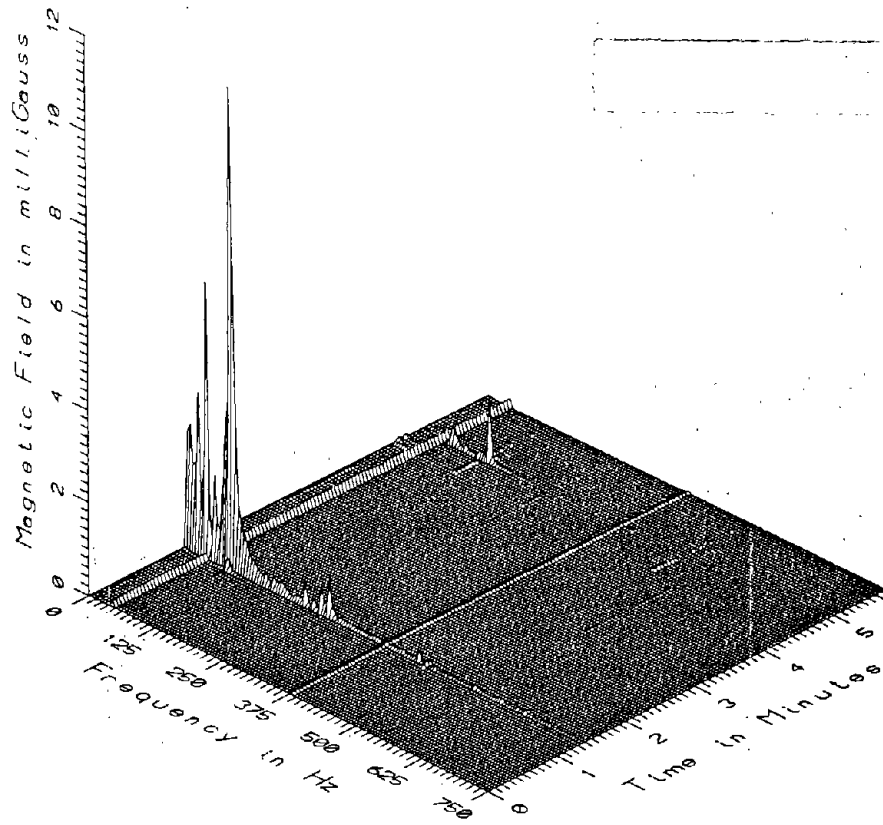

TR7014 - 10M WEST OF HIGH STEEL GUIDEWAY

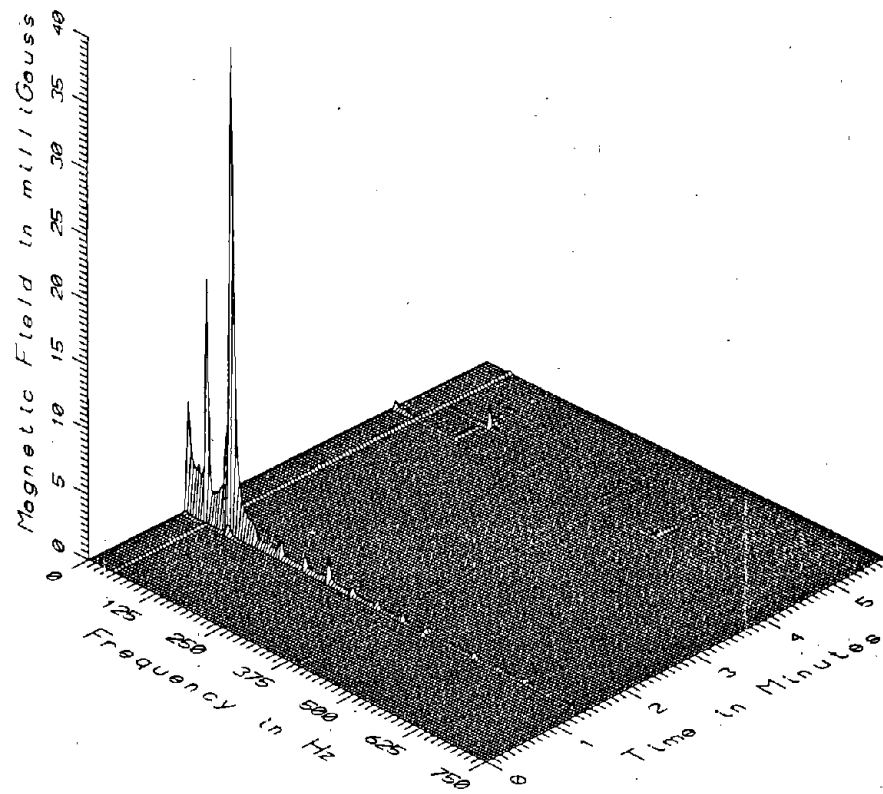

TR7014 - 3M WEST OF HIGH STEEL GUIDEWAY, 25M SOUTH OF PROFILE

K-4

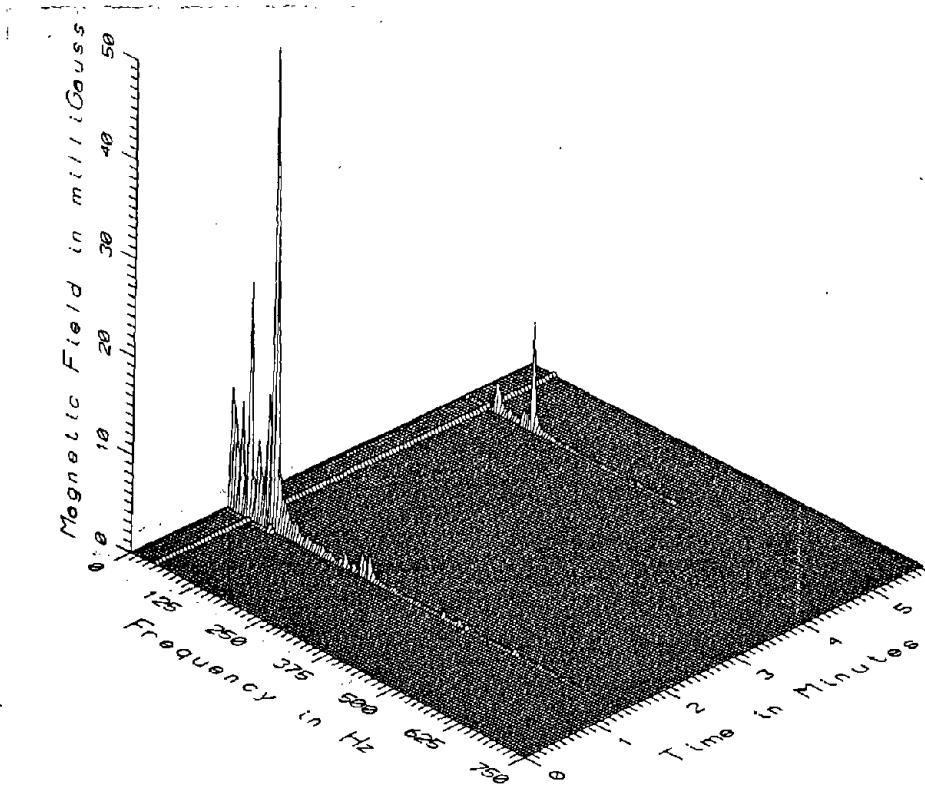

TR7014 - 3M WEST OF HIGH STEEL GUIDEWAY, 25M NORTH OF PROFILE

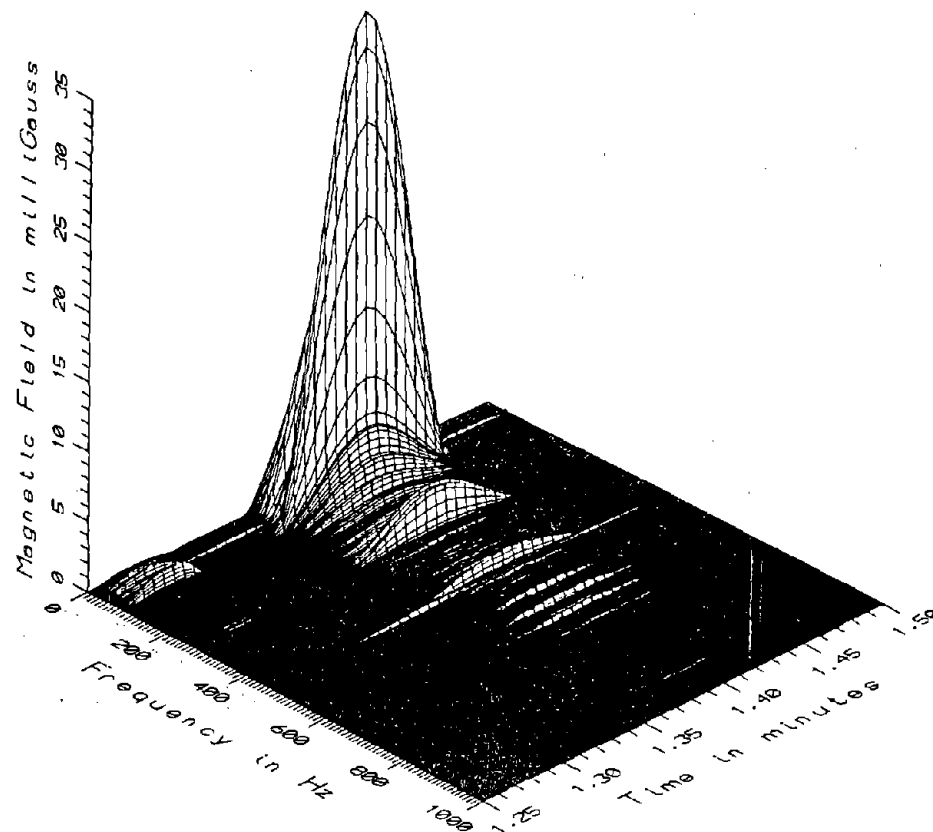

TR7014 - PROFILE OF HIGH STEEL GUIDEWAY - UNDER CENTER OF GUIDEWAY

K-5

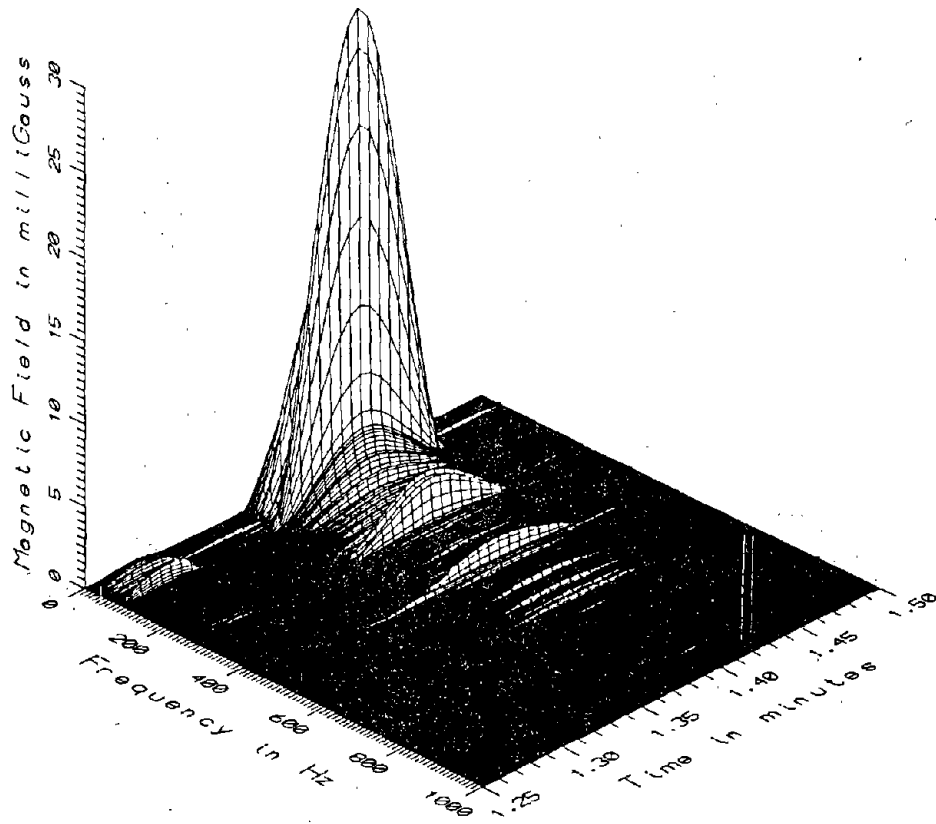

TR7014 - PROFILE OF HIGH STEEL GUIDEWAY - 3M FROM CENTER OF GUIDEWAY

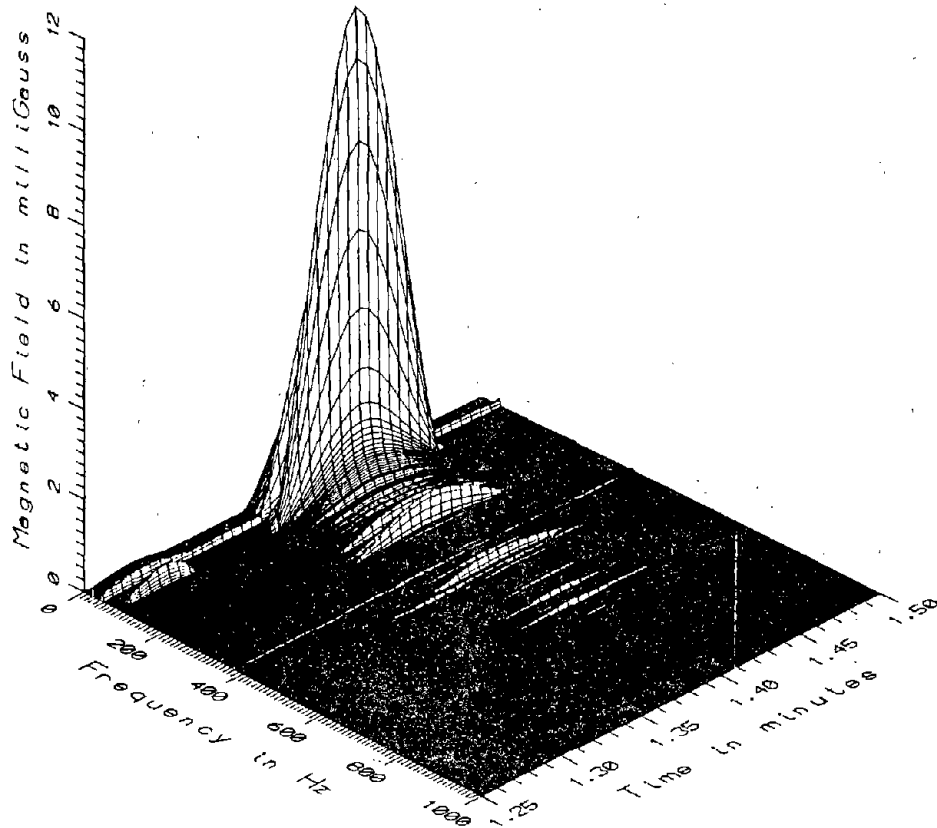

TR7014 - PROFILE OF HIGH STEEL GUIDEWAY - 10M FROM CENTER OF GUIDEWAY

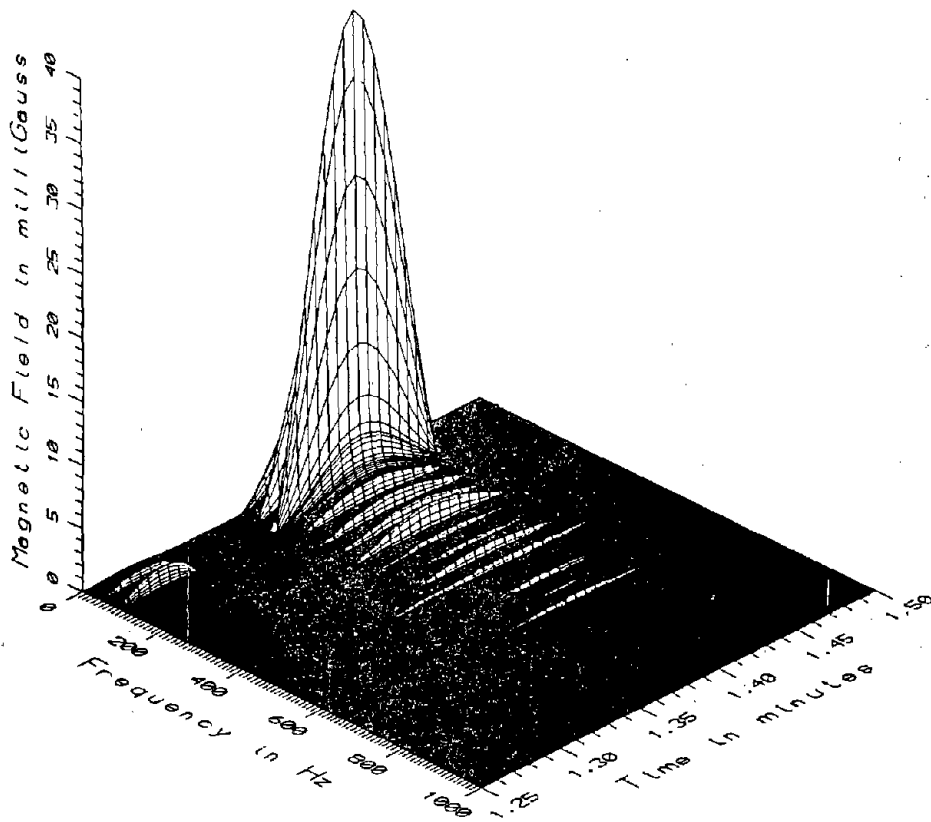

TR7014 - PROFILE OF HIGH STEEL GUIDEWAY - 3M FROM CENTER OF GUIDEWAY, 25M SOUTH

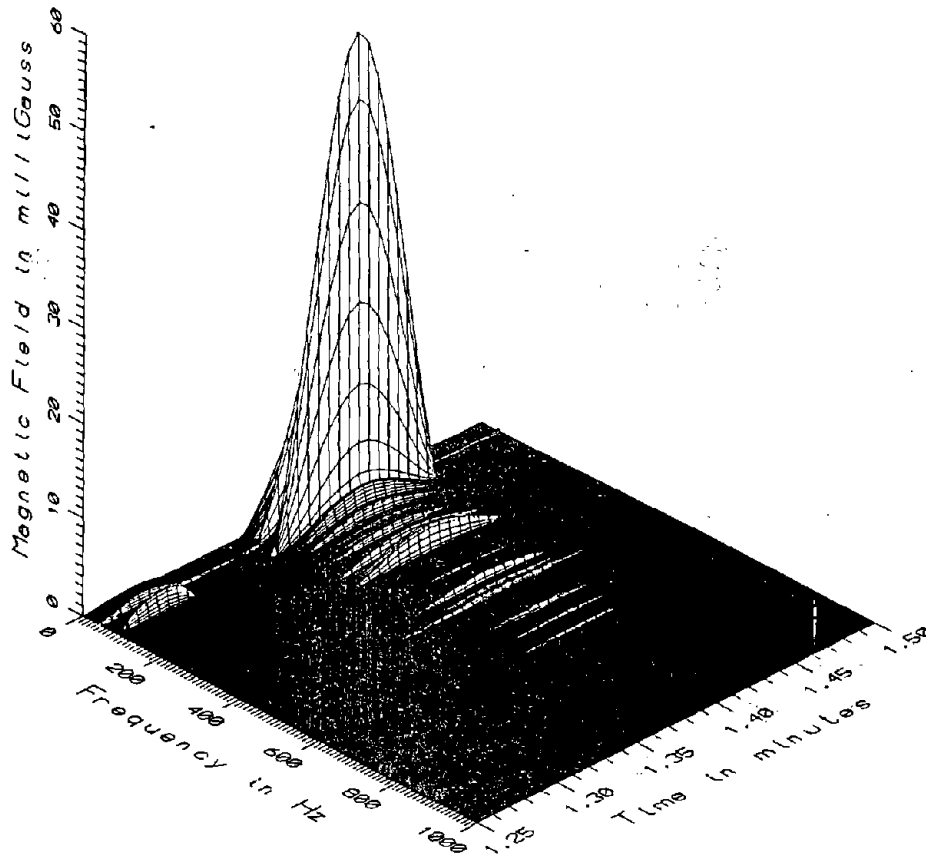

TR7014 - PROFILE OF HIGH STEEL GUIDEWAY - 3M FROM CENTER OF GUIDEWAY, 25M NORTH

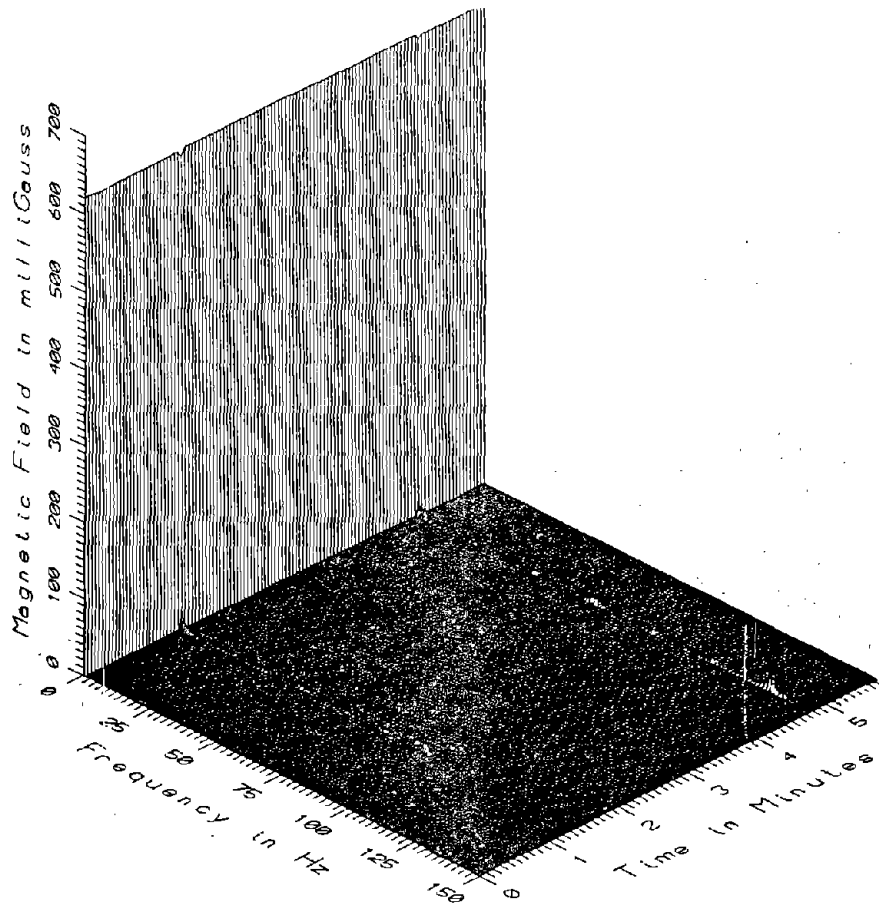

TR7014 - UNDER CENTER OF HIGH STEEL GUIDEWAY

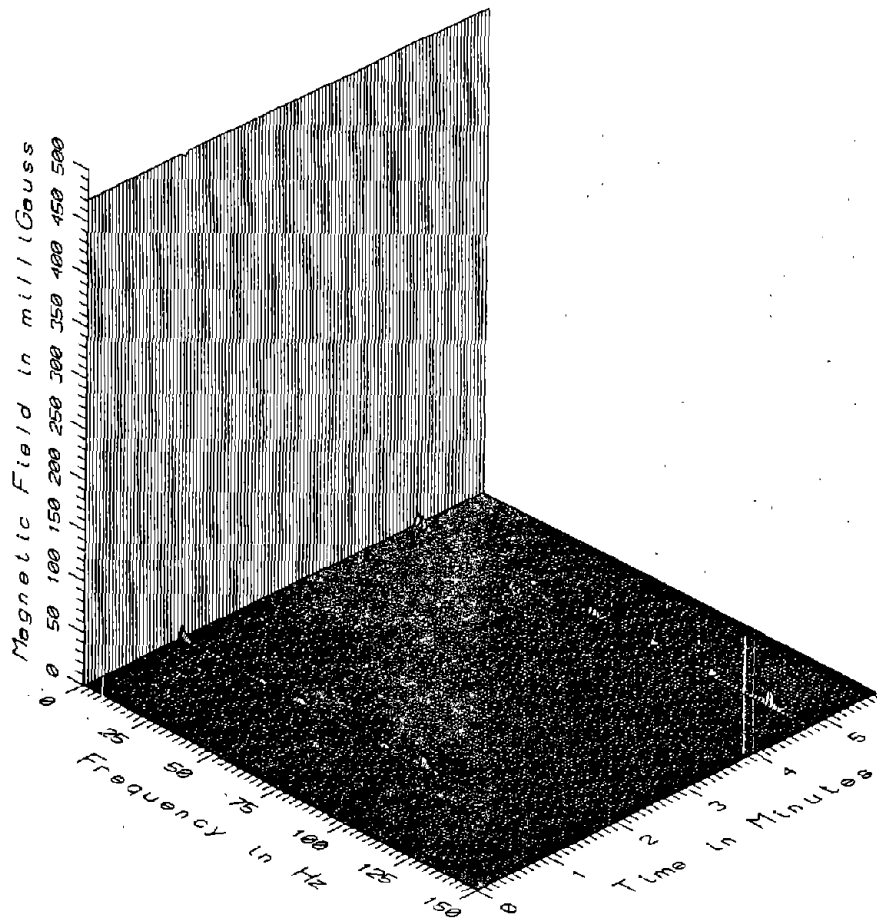

TR7014 - 3M WEST OF HIGH STEEL GUIDEWAY

K-8

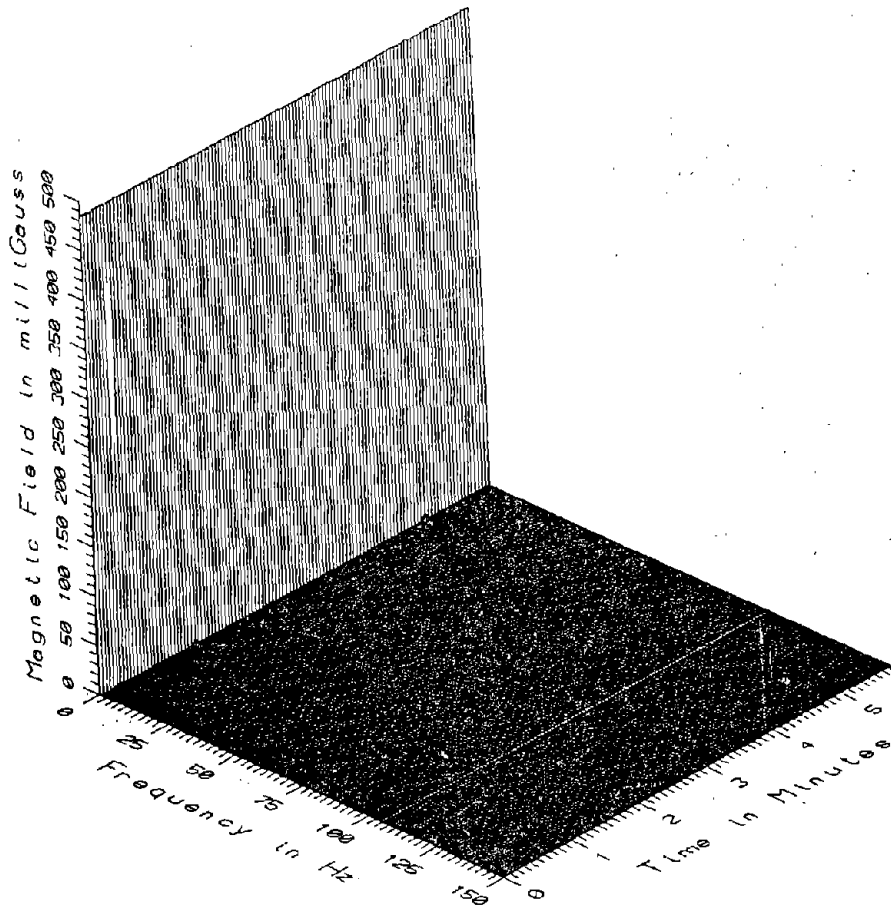

TR7014 - 10M WEST OF HIGH STEEL GUIDEWAY

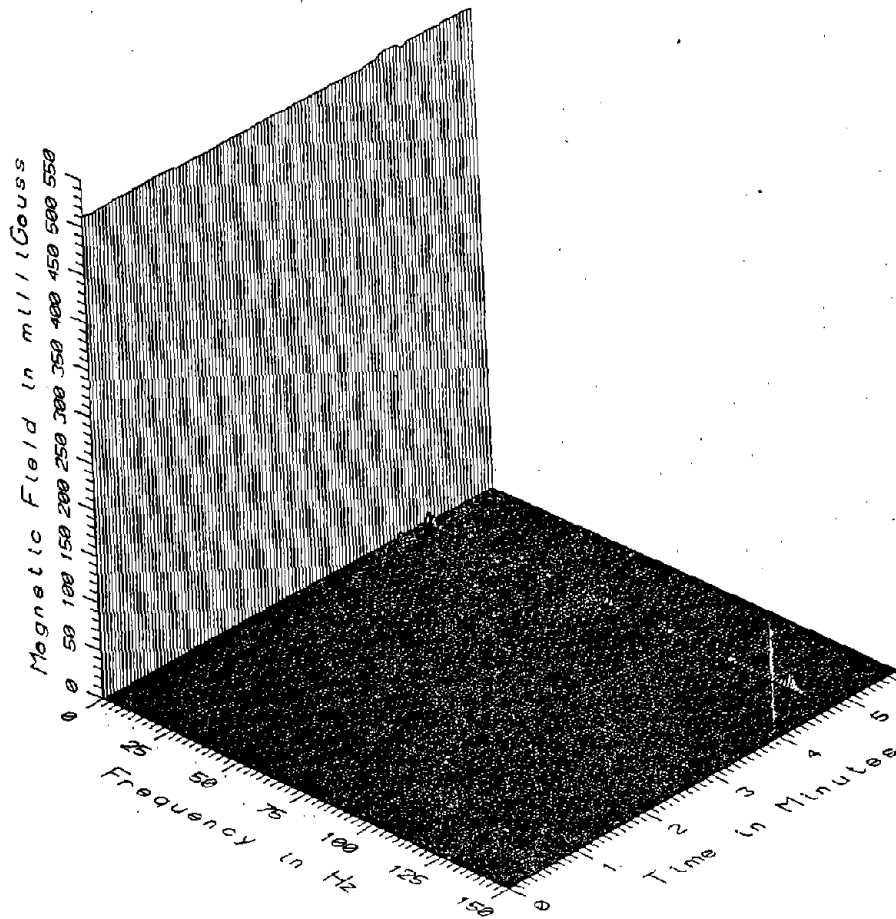

TR7014 - 3M WEST OF HIGH STEEL GUIDEWAY, 25M SOUTH OF PROFILE

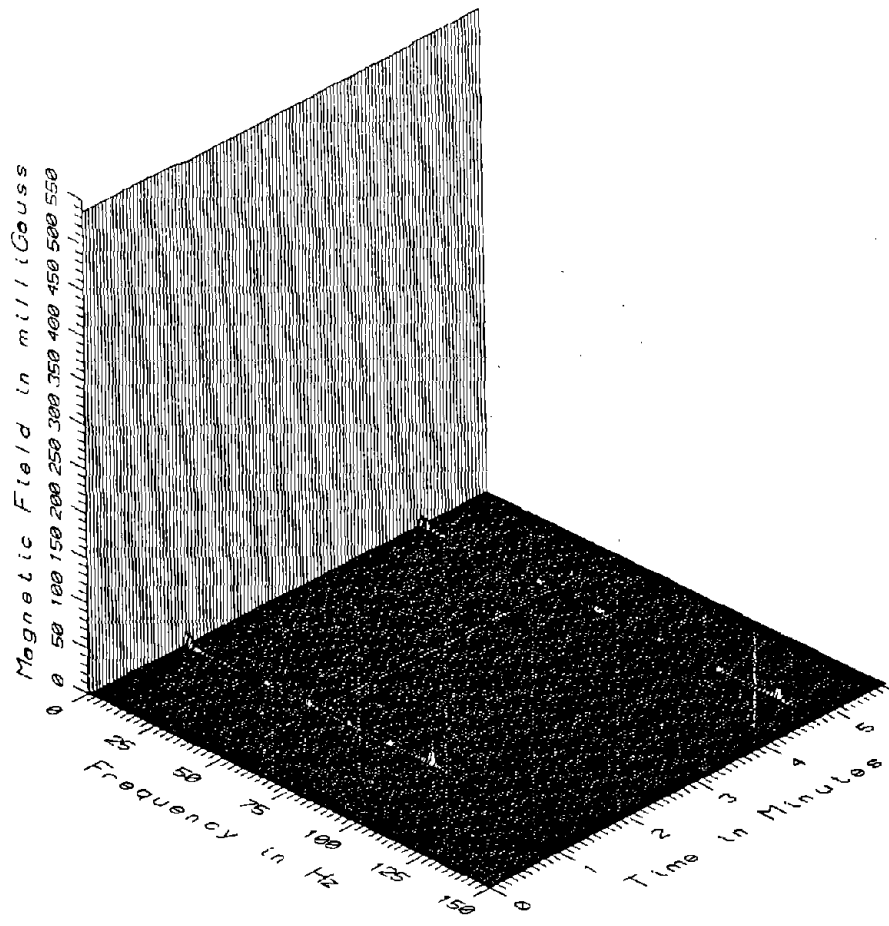

TR7014 - 3M WEST OF HIGH STEEL GUIDEWAY, 25M NORTH OF PROFILE

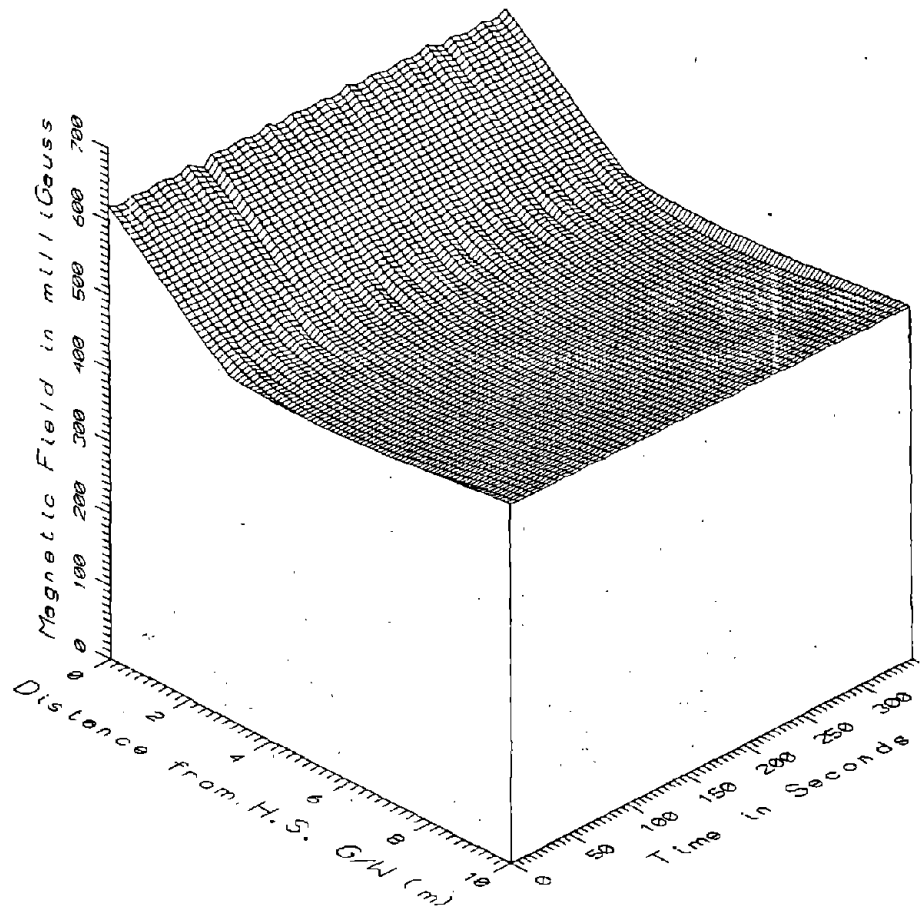

TR7014, HIGH STEEL GUIDEWAY - DC

K-10

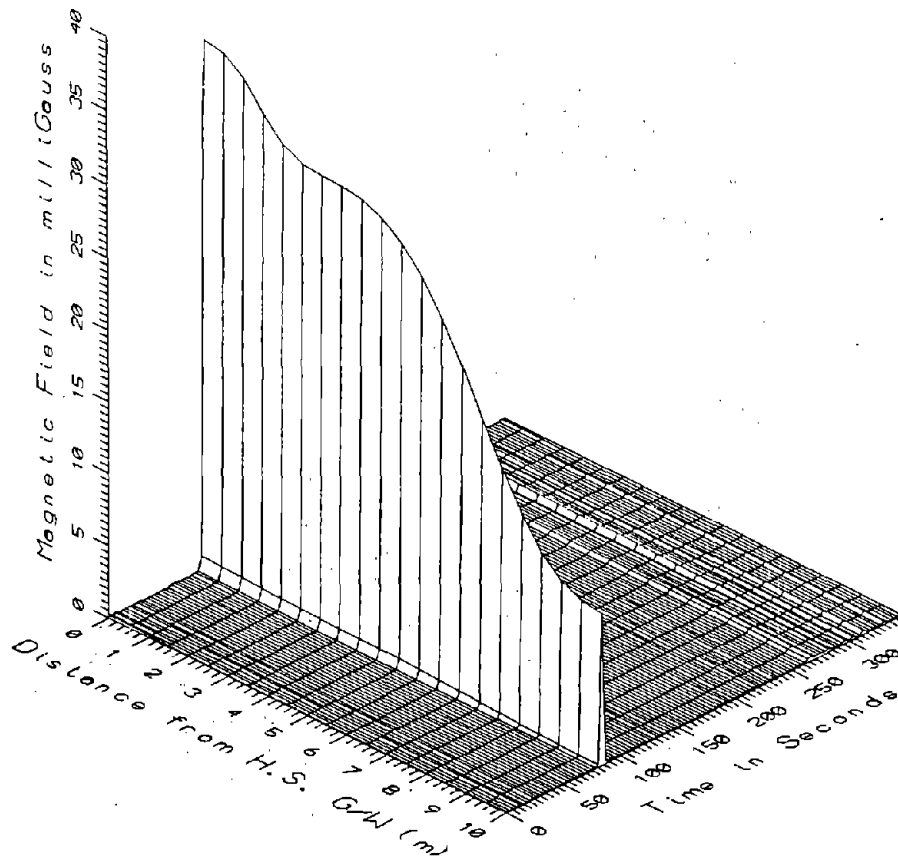

TR7014, HIGH STEEL GUIDEWAY - LOW FREQUENCY, 5-45Hz

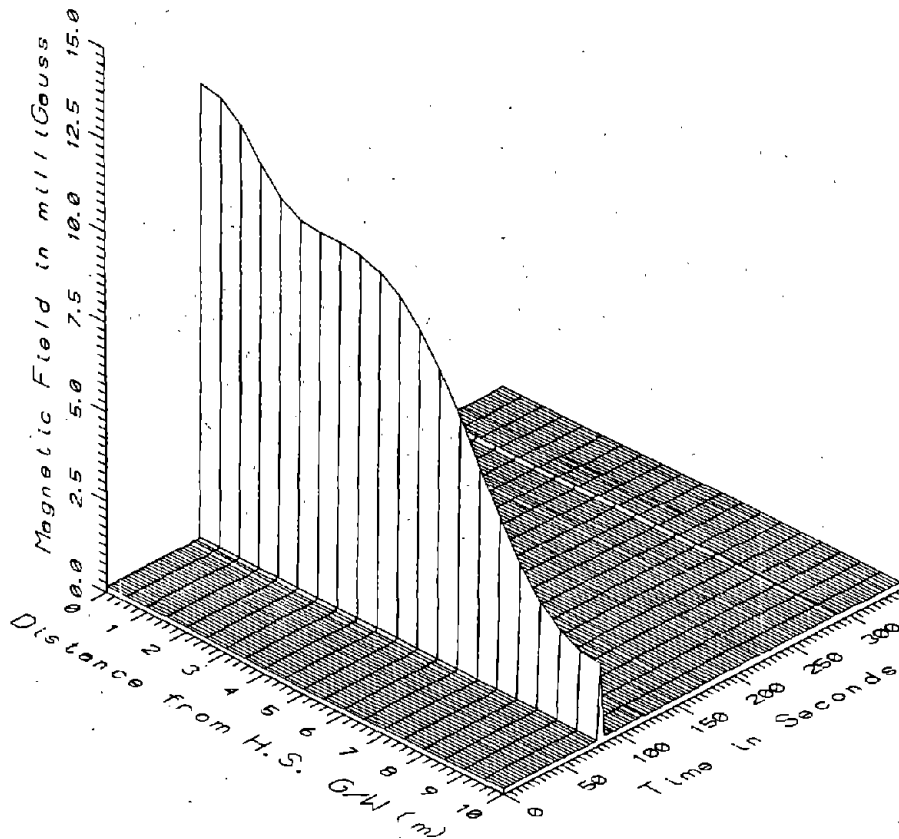

TR7014, HIGH STEEL GUIDEWAY - POWER FREQUENCY, 50-60Hz

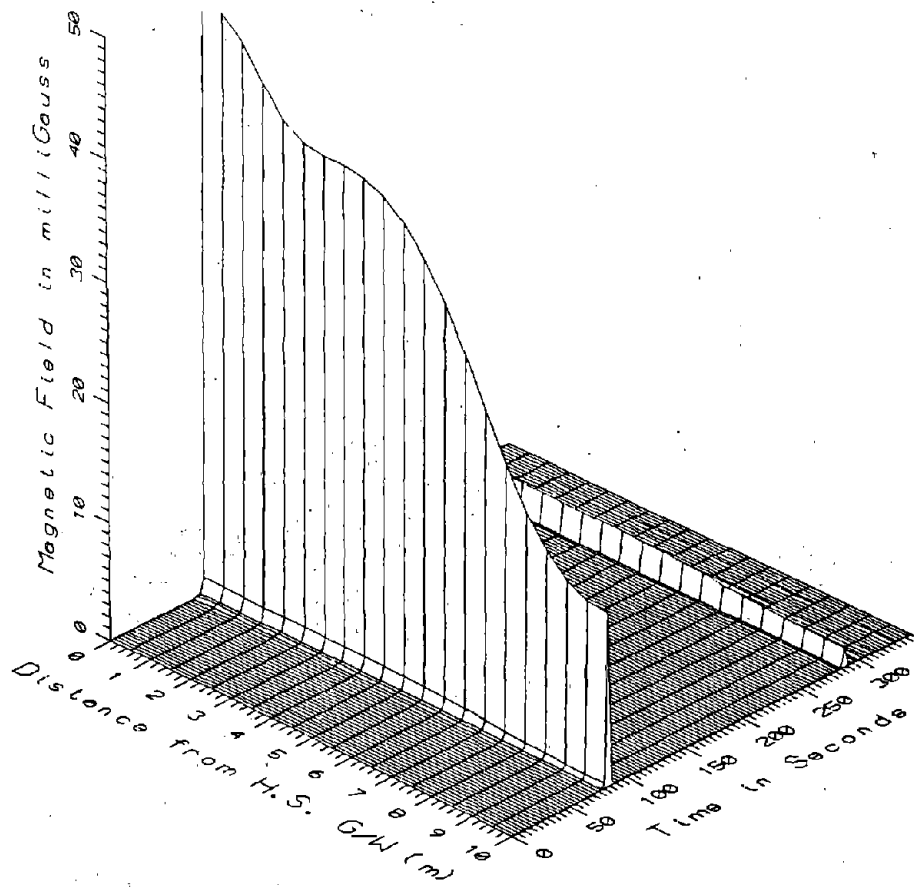

TR7014, HIGH STEEL GUIDEWAY - POWER HARMONICS, 65-300Hz

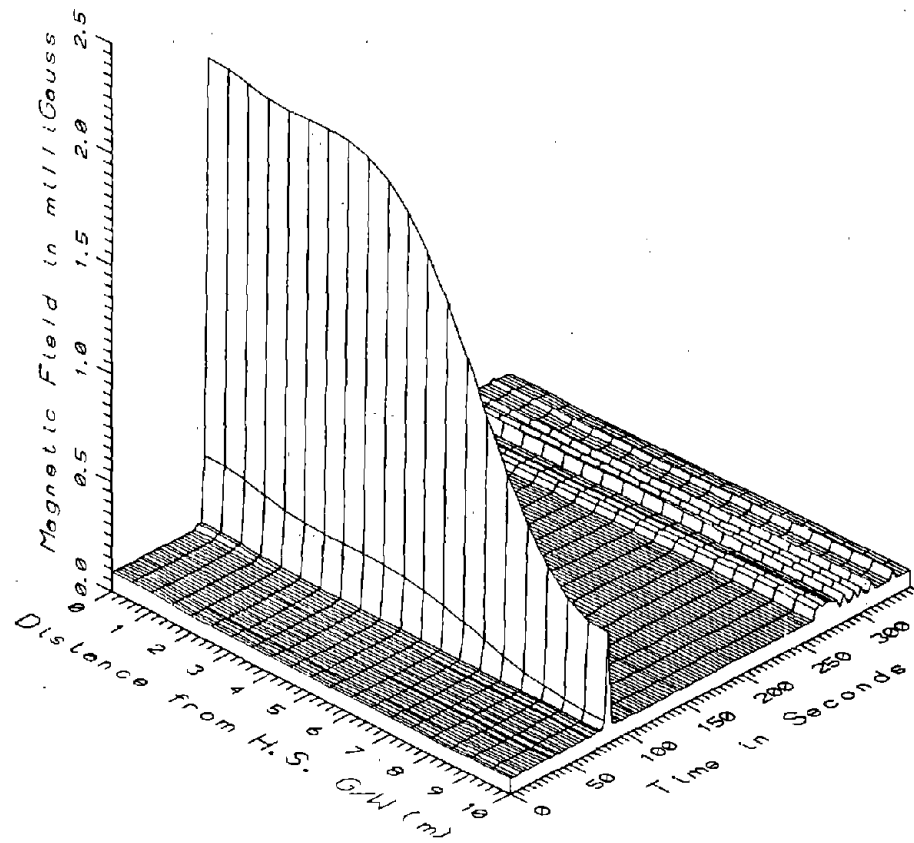

TR7014, HIGH STEEL GUIDEWAY - HIGH FREQUENCY, 305-2560Hz

k-13

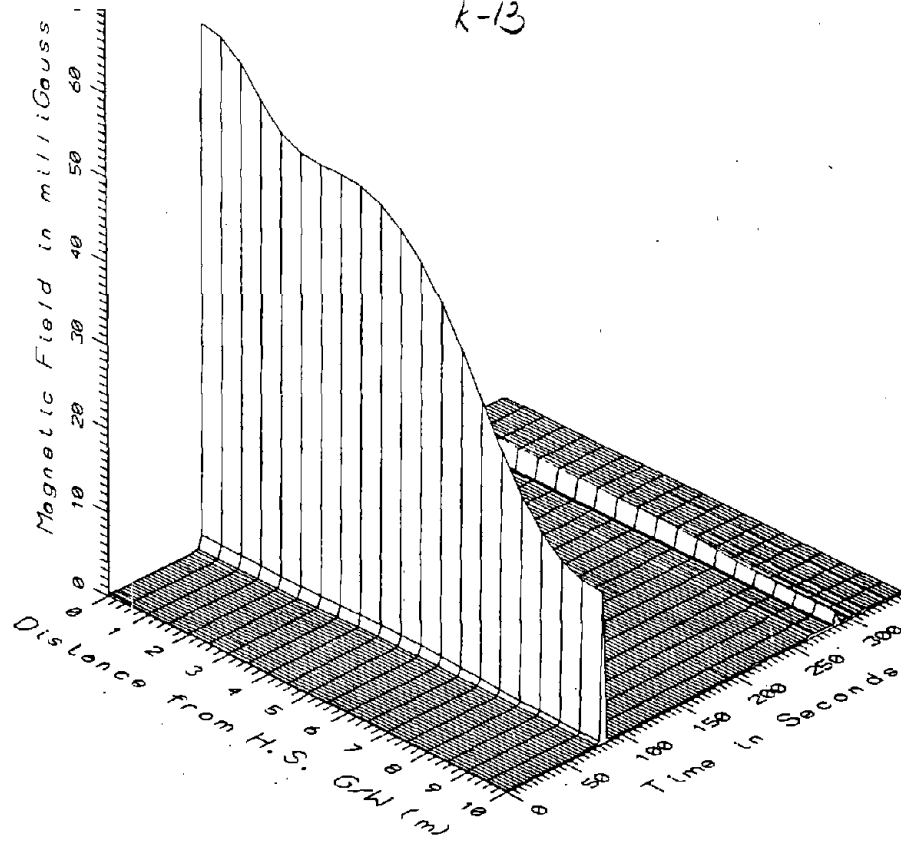

TR7014. HIGH STEEL GUIDEWAY - ALL FREQUENCIES, 5-2560Hz

L-1

APPENDIX L
DATA SET TR7015
LATERAL PROFILE
BENEATH THE HIGH STEEL GUIDEWAY

L-1

APPENDIX L

DATA SET TR7015
LATERAL PROFILE BENEATH THE HIGH STEEL GUIDEWAY

Measurement Setup Code: 18
Vehicle Status: Running continuously
Measurement Date: August 8, 1990
Measurement Time: Start: 12:39:20
End: 12:40:32
Number of Samples: 13
Programmed Sample Interval: 3 sec
Actual Sample Interval: 6 sec

Frequency Spectrum Parameters

<u>Probe Type:</u>	<u>Coil (AC)</u>	<u>Fluxgate (DC)</u>
Maximum Frequency (Hz)	2560	256
Minimum Frequency (Hz)	5	0
Spectral Bandwidth (Hz)	5	0.5

Missing or Suspect Data: None

SETUP 18, 19: HIGH STEEL GUIDEWAY, PILLAR 2423 NEAR CONTROL CENTER

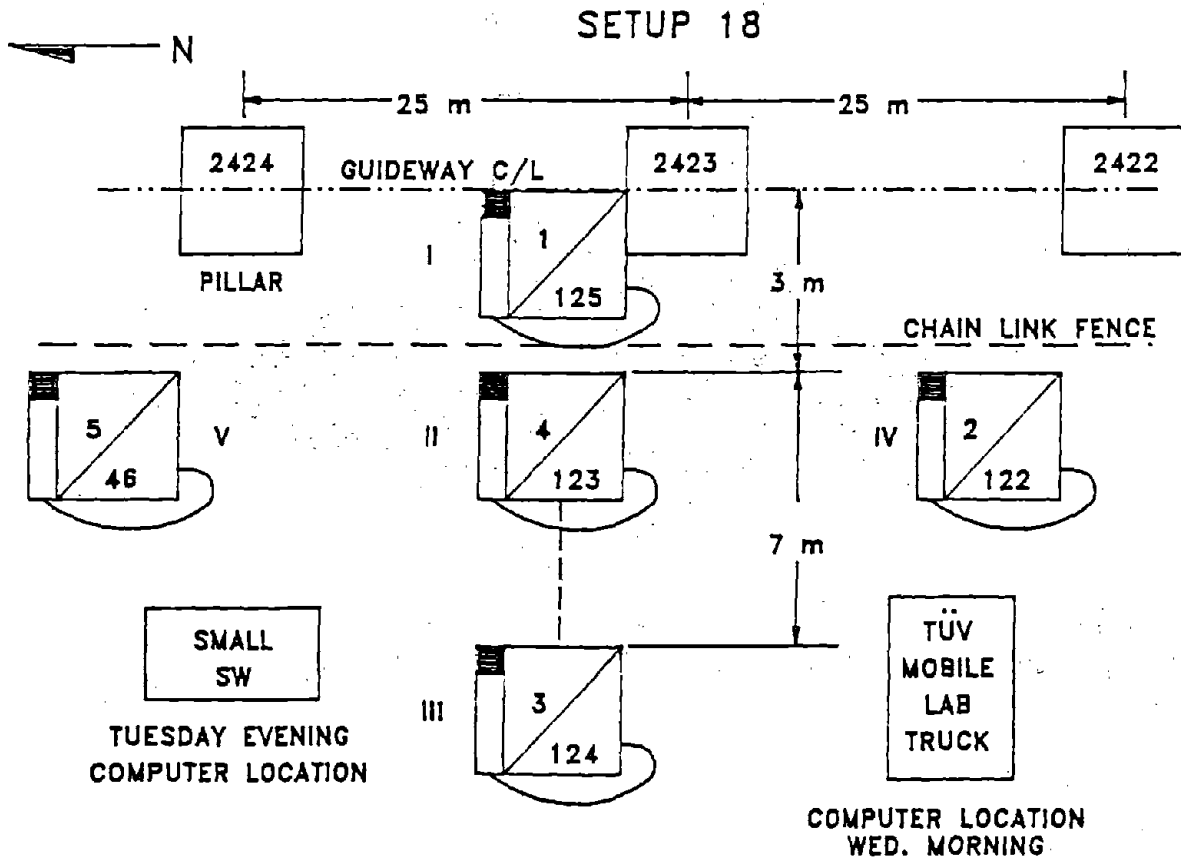

TOP VIEW OF ALL PROBE ORIENTATIONS

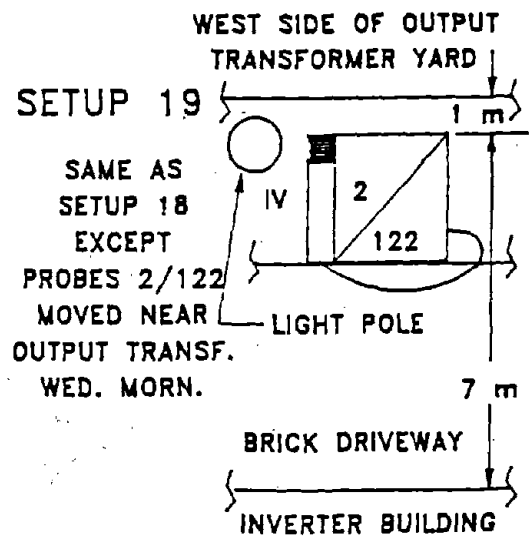
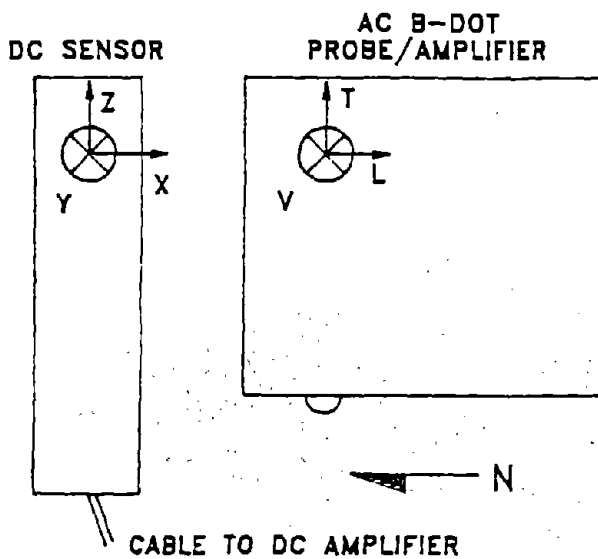

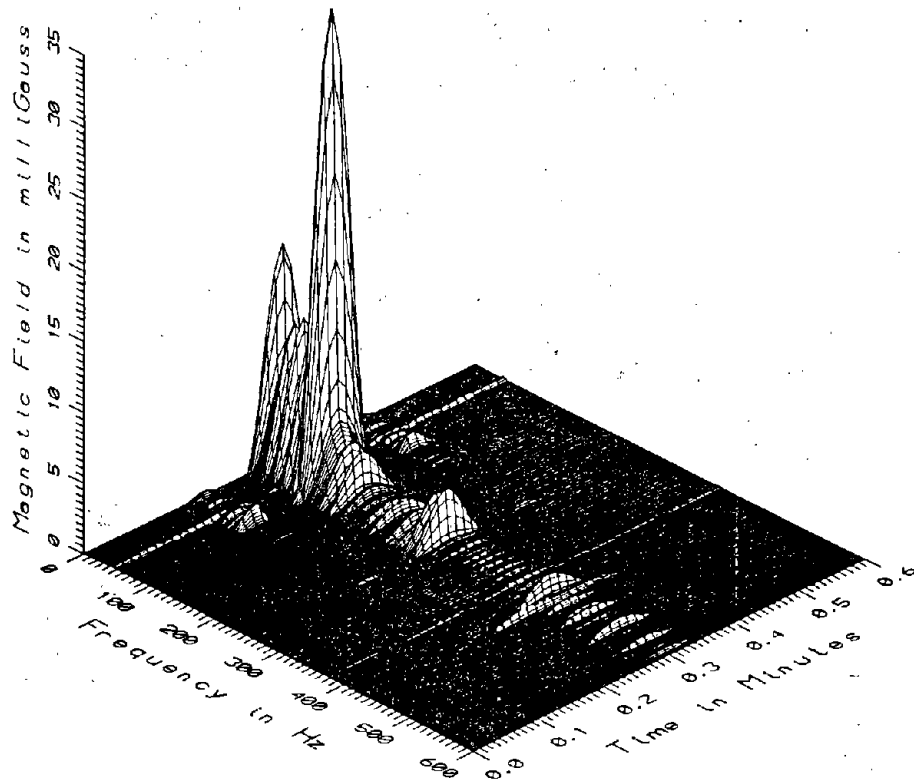

TR7015 - UNDER CENTER OF HIGH STEEL GUIDEWAY

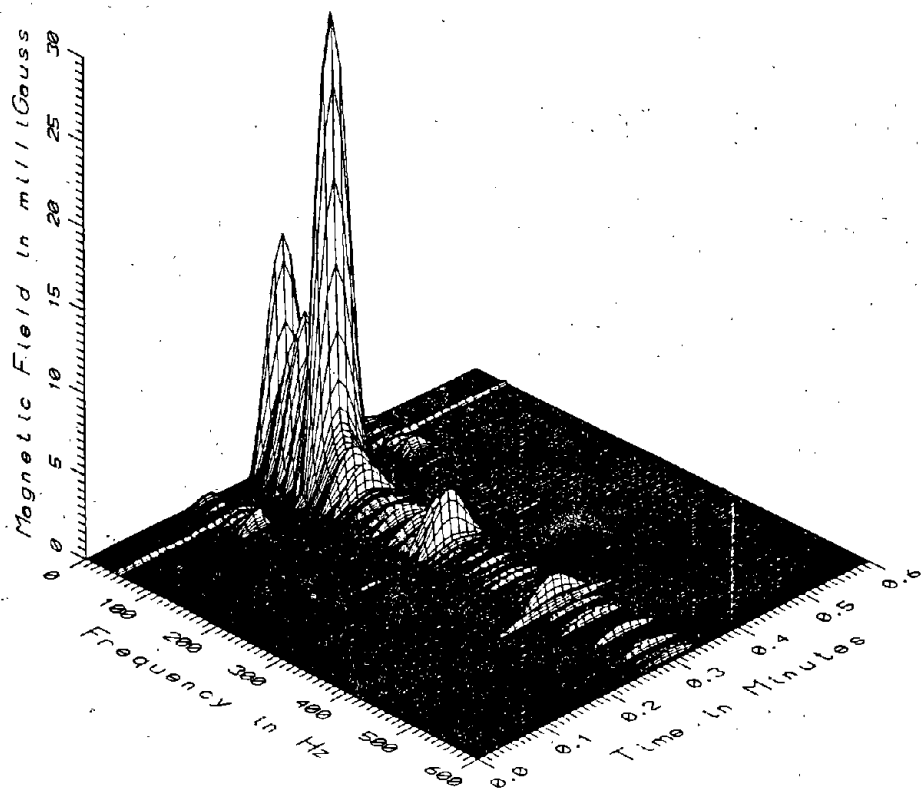

TR7015 - 3M WEST OF HIGH STEEL GUIDEWAY

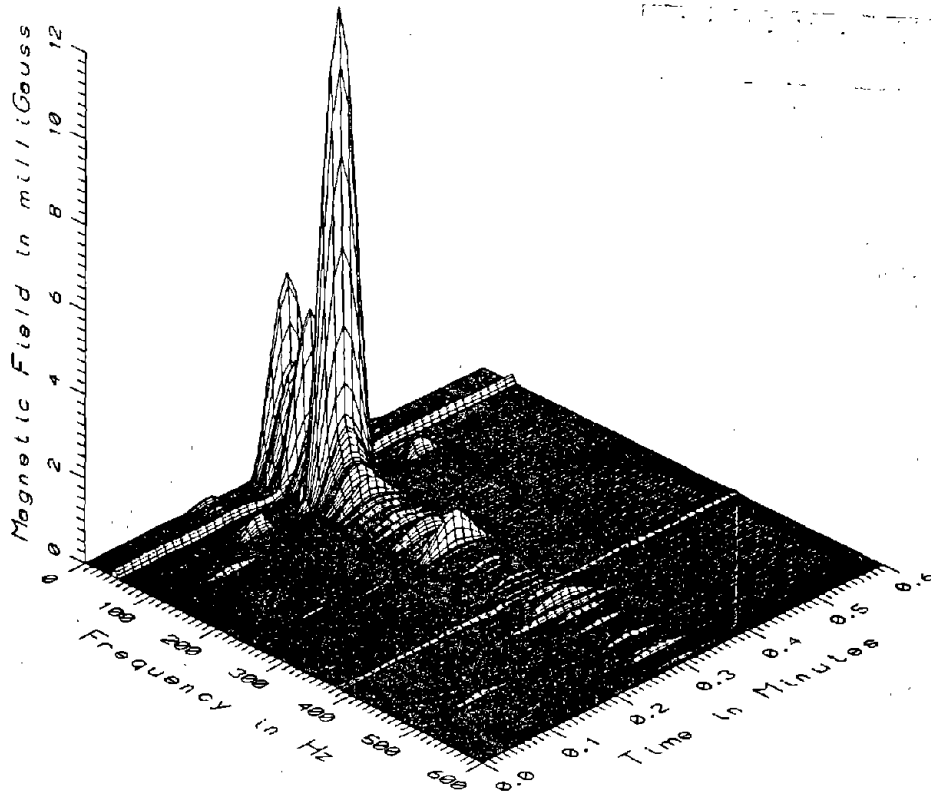

TR7015 - 10M WEST OF HIGH STEEL GUIDEWAY

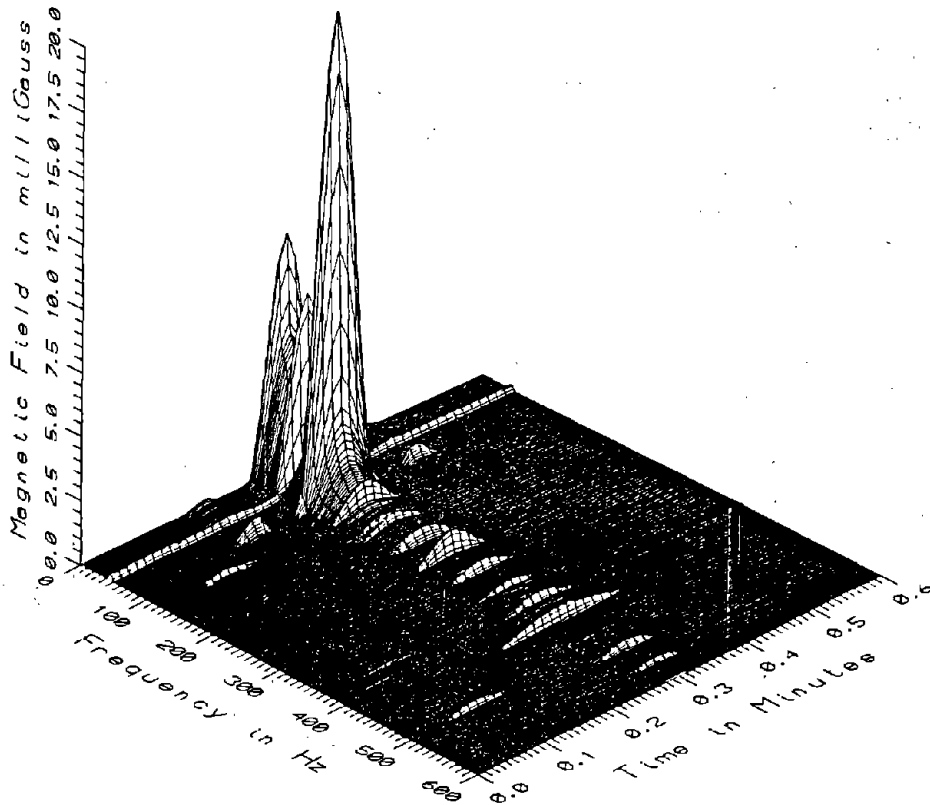

TR7015 - 3M WEST OF HIGH STEEL GUIDEWAY, 25M SOUTH OF PROFILE

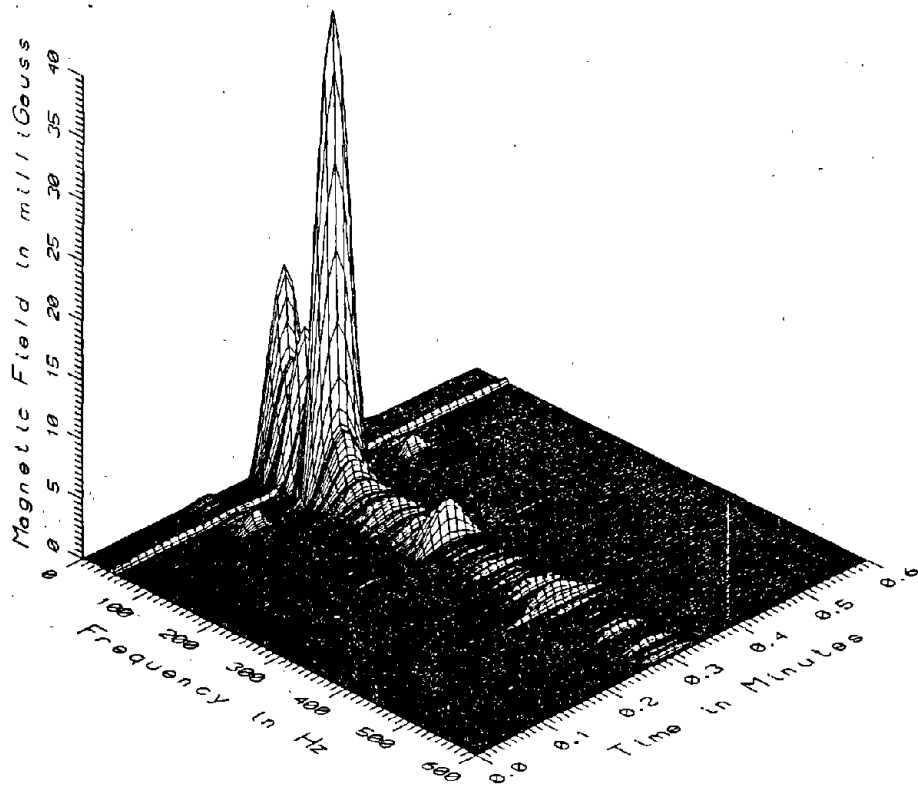

TR7015 - 3M WEST OF HIGH STEEL GUIDEWAY, 25M NORTH OF PROFILE

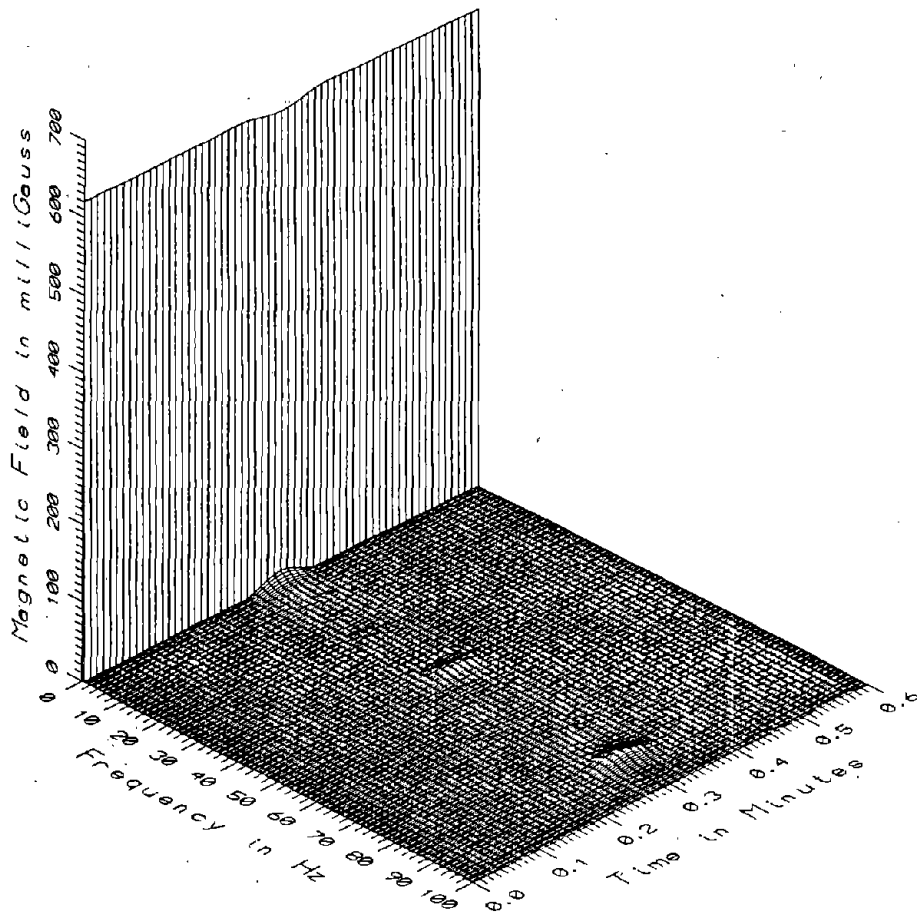

TR7015 - UNDER CENTER OF HIGH STEEL GUIDEWAY

L-5

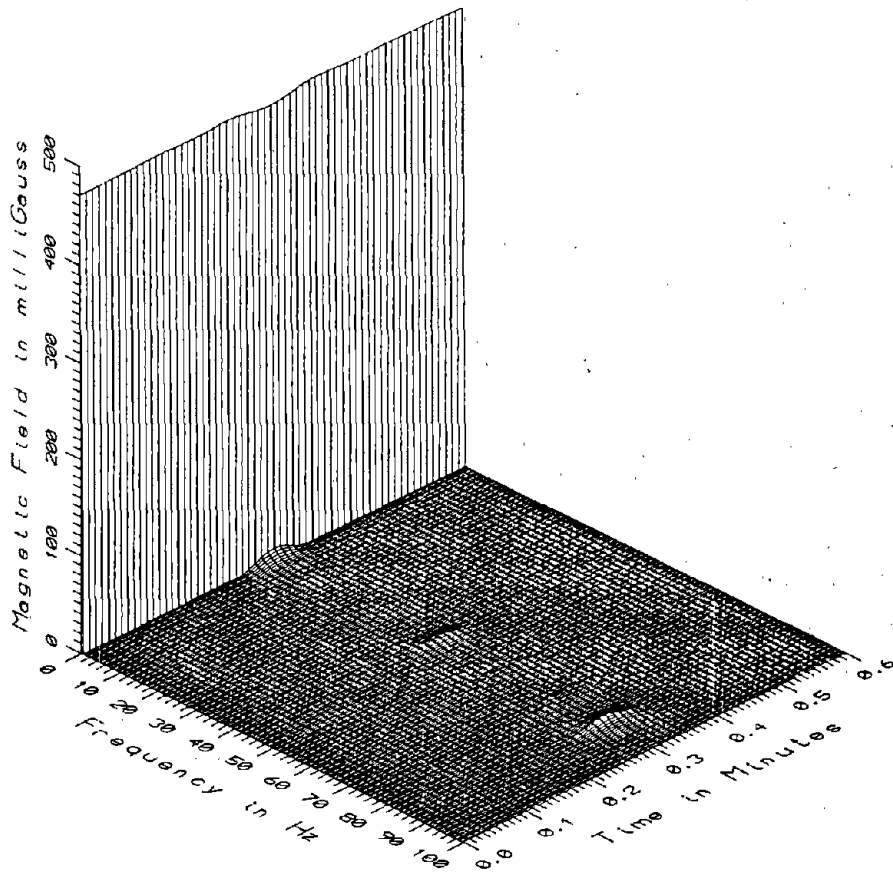

TR7015 - 3M WEST OF HIGH STEEL GUIDEWAY

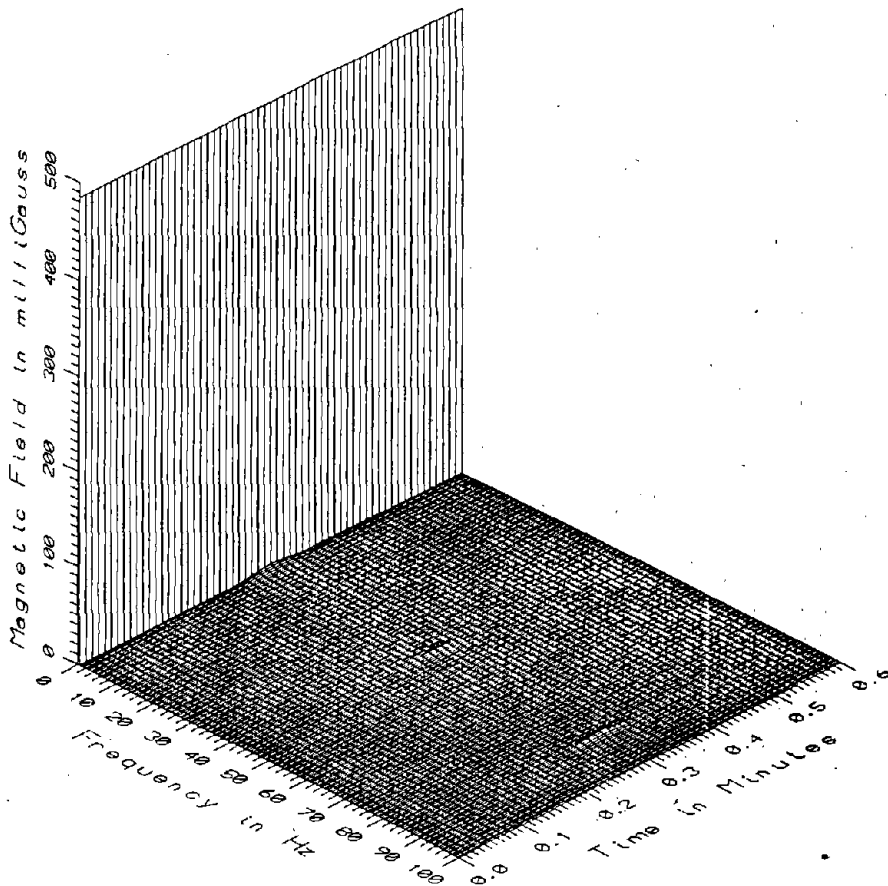

TR7015 - 10M WEST OF HIGH STEEL GUIDEWAY

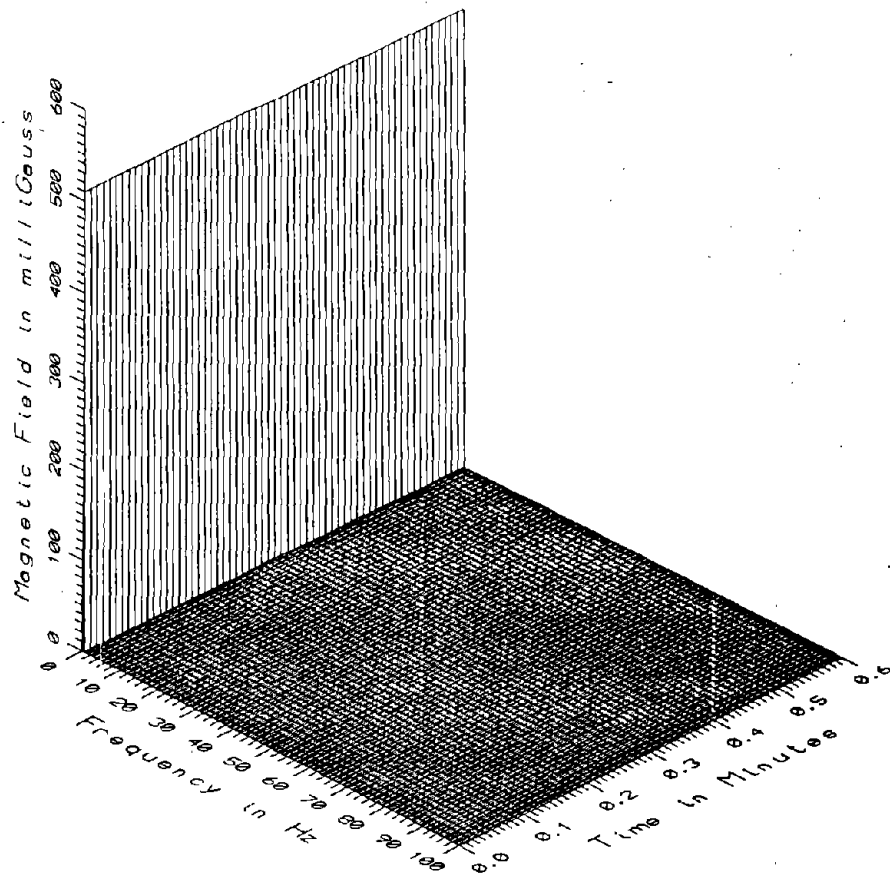

TR7015 - 3M WEST OF HIGH STEEL GUIDEWAY, 25M SOUTH OF PROFILE

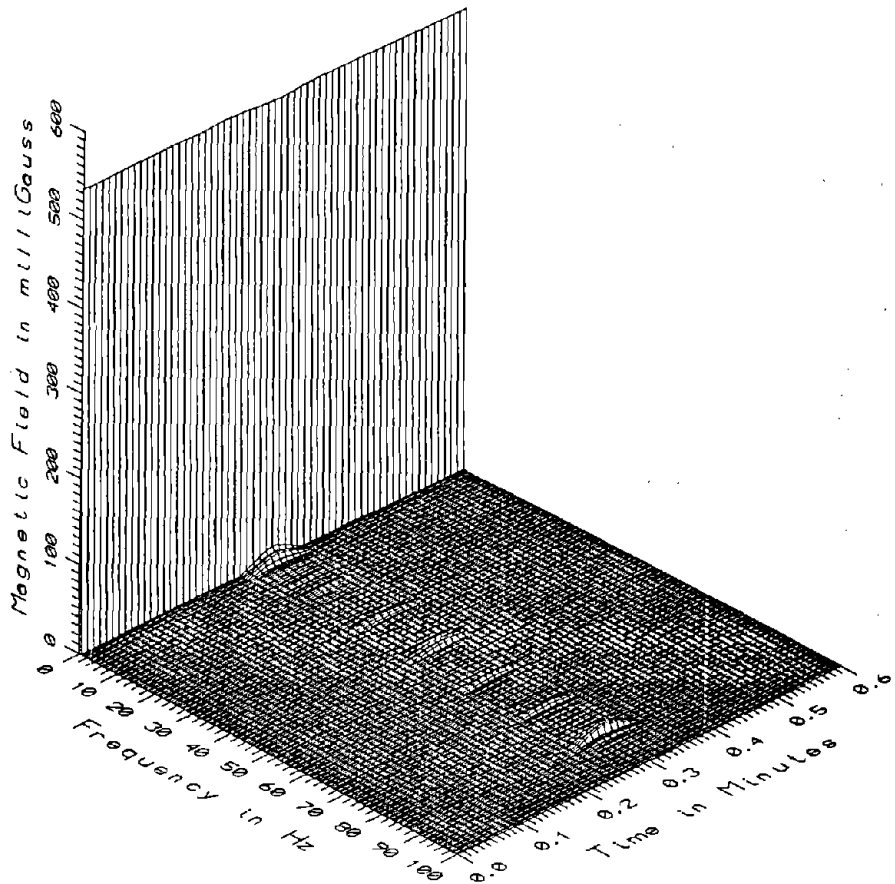

TR7015 - 3M WEST OF HIGH STEEL GUIDEWAY, 25M NORTH OF PROFILE

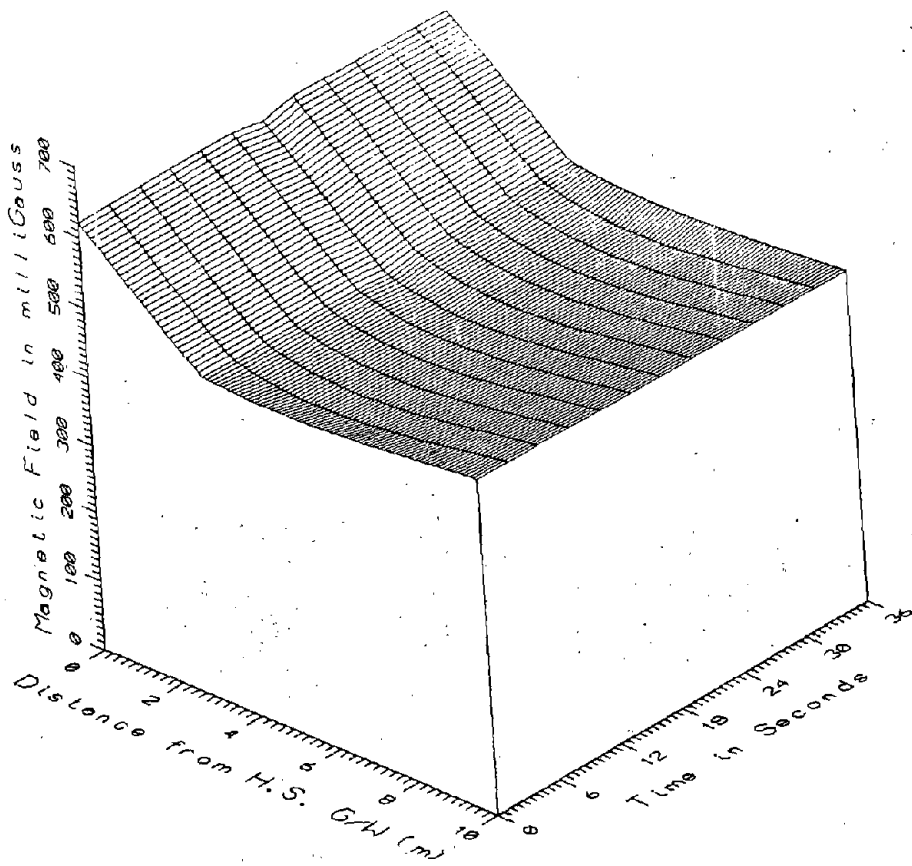

TR7015, HIGH STEEL GUIDEWAY - DC

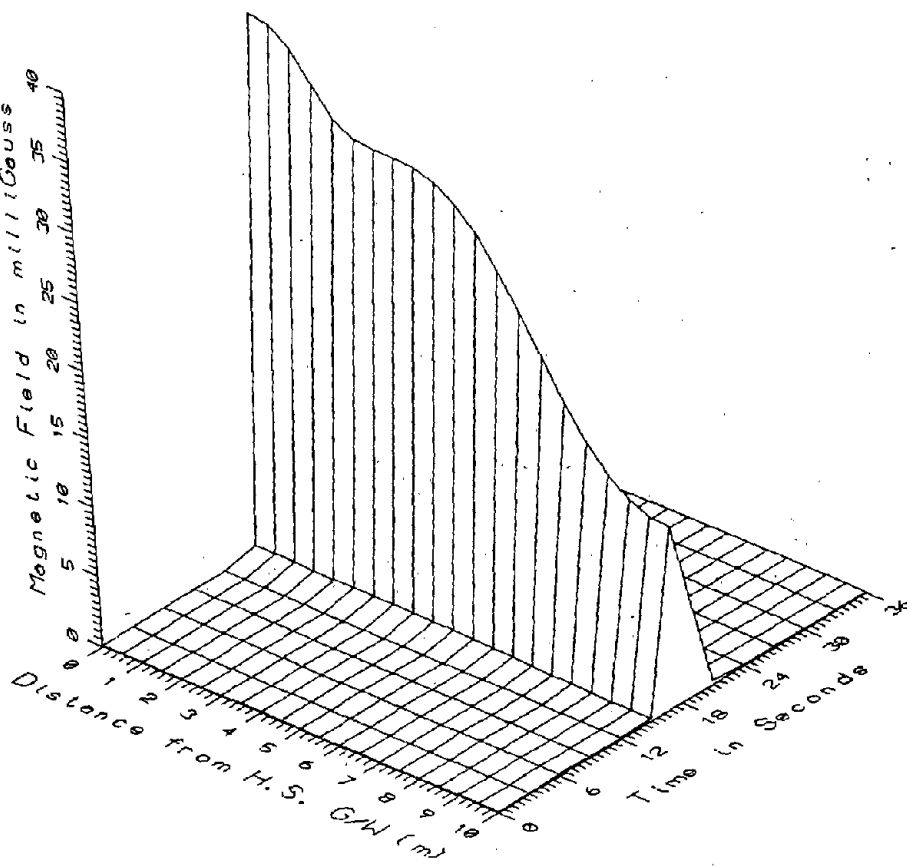

TR7015, HIGH STEEL GUIDEWAY - LOW FREQUENCY, 5 kHz

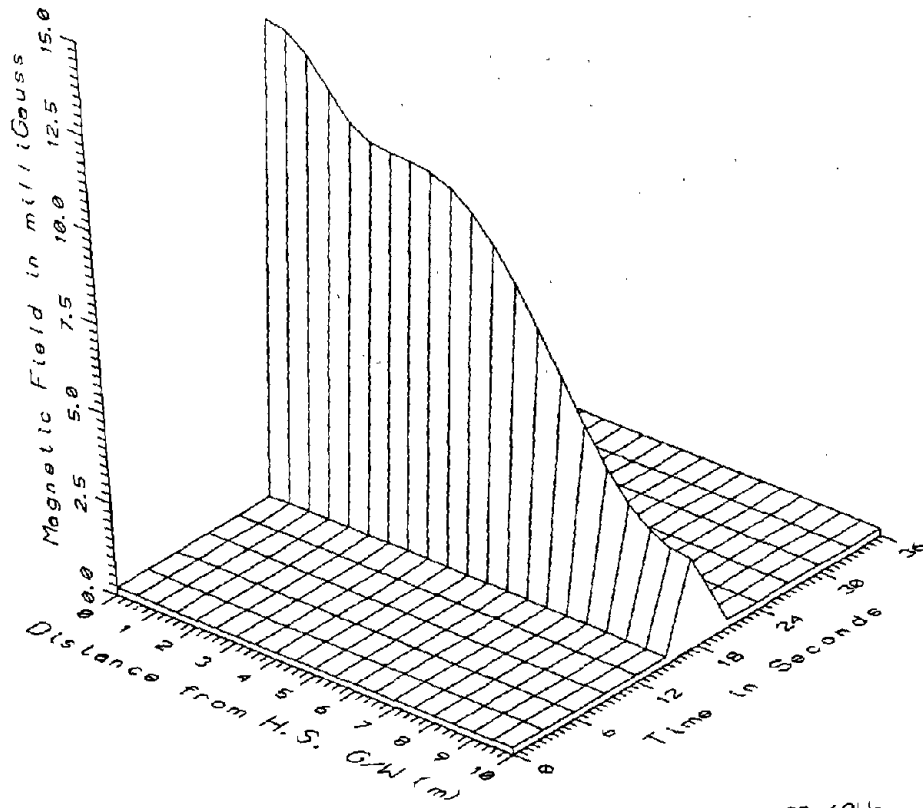

TR7015, HIGH STEEL GUIDEWAY - POWER FREQUENCY, 50-60Hz

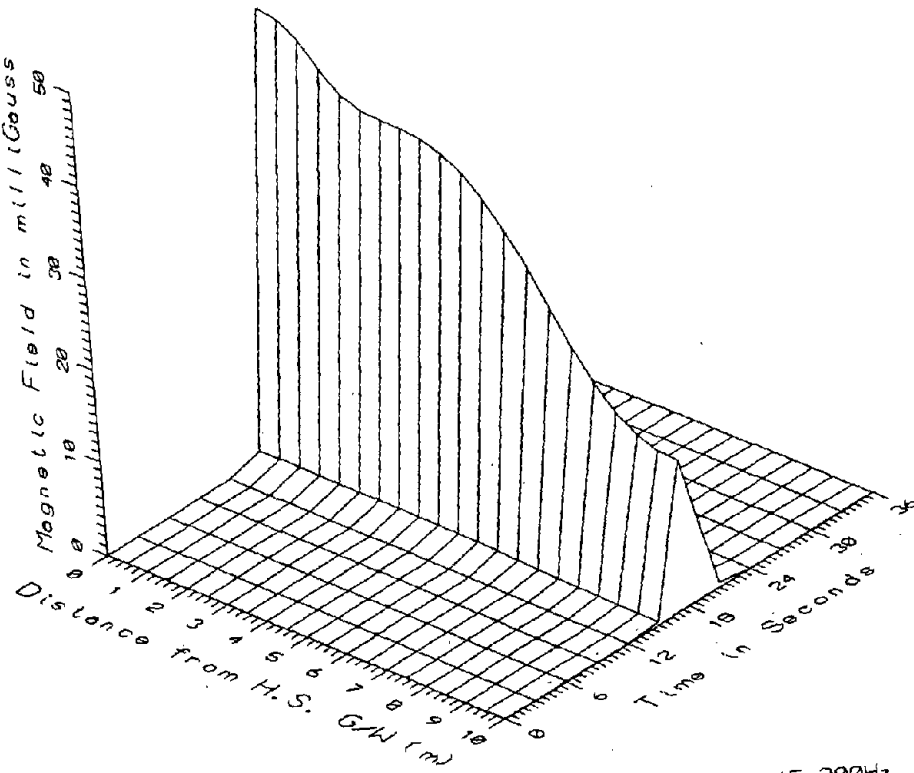

TR7015, HIGH STEEL GUIDEWAY - POWER HARMONICS, 65-300Hz

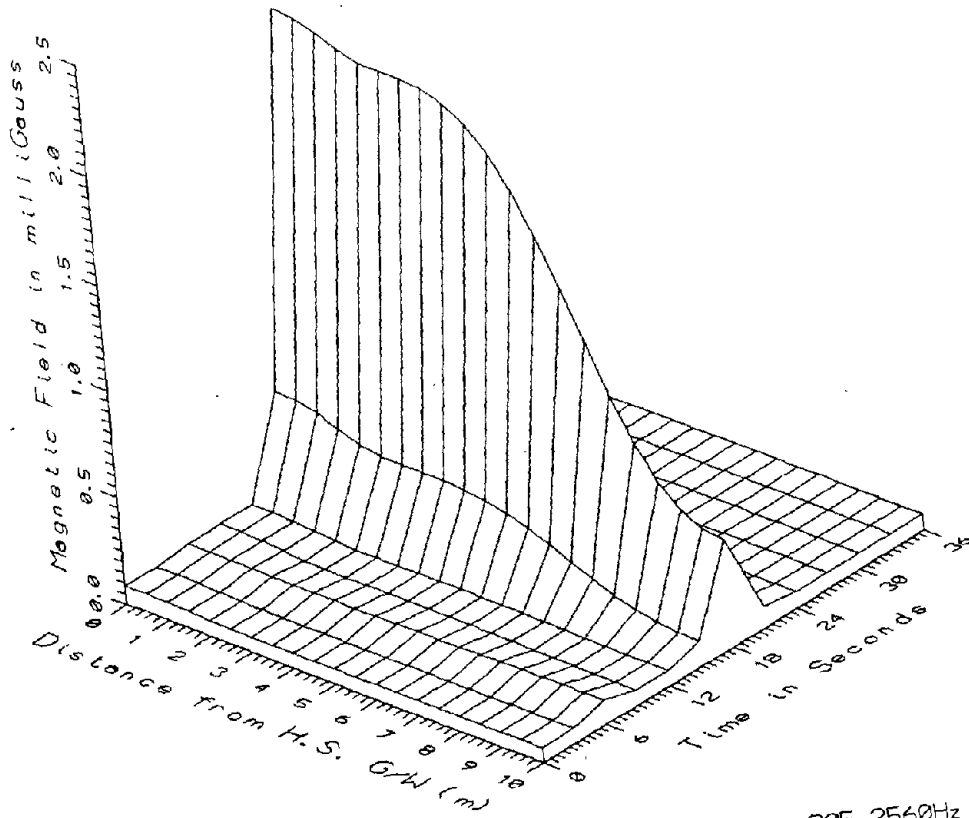

TR015, HIGH STEEL GUIDEWAY - HIGH FREQUENCY, 305-2560Hz

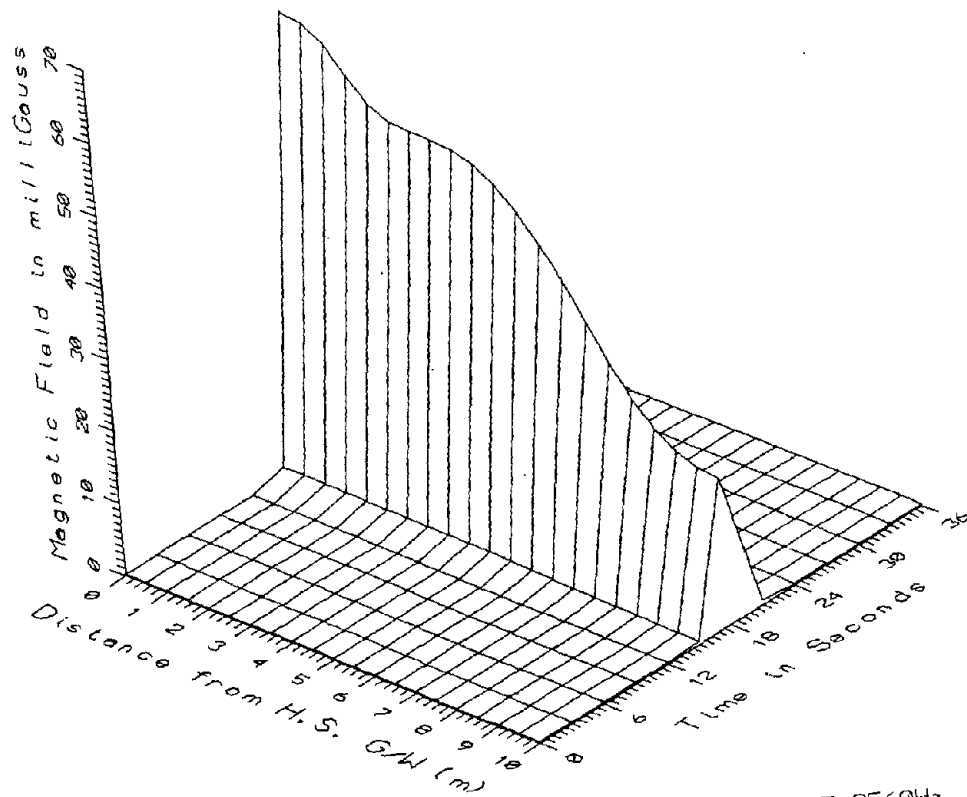

TR015, HIGH STEEL GUIDEWAY - ALL FREQUENCIES, 5-2560Hz

M-i

APPENDIX M
DATA SET TR7017
LATERAL PROFILE
BENEATH THE HIGH STEEL GUIDEWAY

M-1

APPENDIX M

DATA SET TR7017
LATERAL PROFILE BENEATH THE HIGH STEEL GUIDEWAY

Measurement Setup Code: 18
Vehicle Status: Running continuously
Measurement Date: August 8, 1990
Measurement Time: Start: 12:46:00
End: 12:54:57
Number of Samples: 16*
Programmed Sample Interval: 3 sec
Actual Sample Interval: 6 sec

Frequency Spectrum Parameters

<u>Probe Type:</u>	<u>Coil (AC)</u>	<u>Fluxgate (DC)</u>
Maximum Frequency (Hz)	2560	256
Minimum Frequency (Hz)	5	0
Spectral Bandwidth (Hz)	5	0.5

Missing or Suspect Data: None

* Measurements were suspended when vehicle was in loop section

SETUP 18, 19: HIGH STEEL GUIDEWAY, PILLAR 2423 NEAR CONTROL CENTER

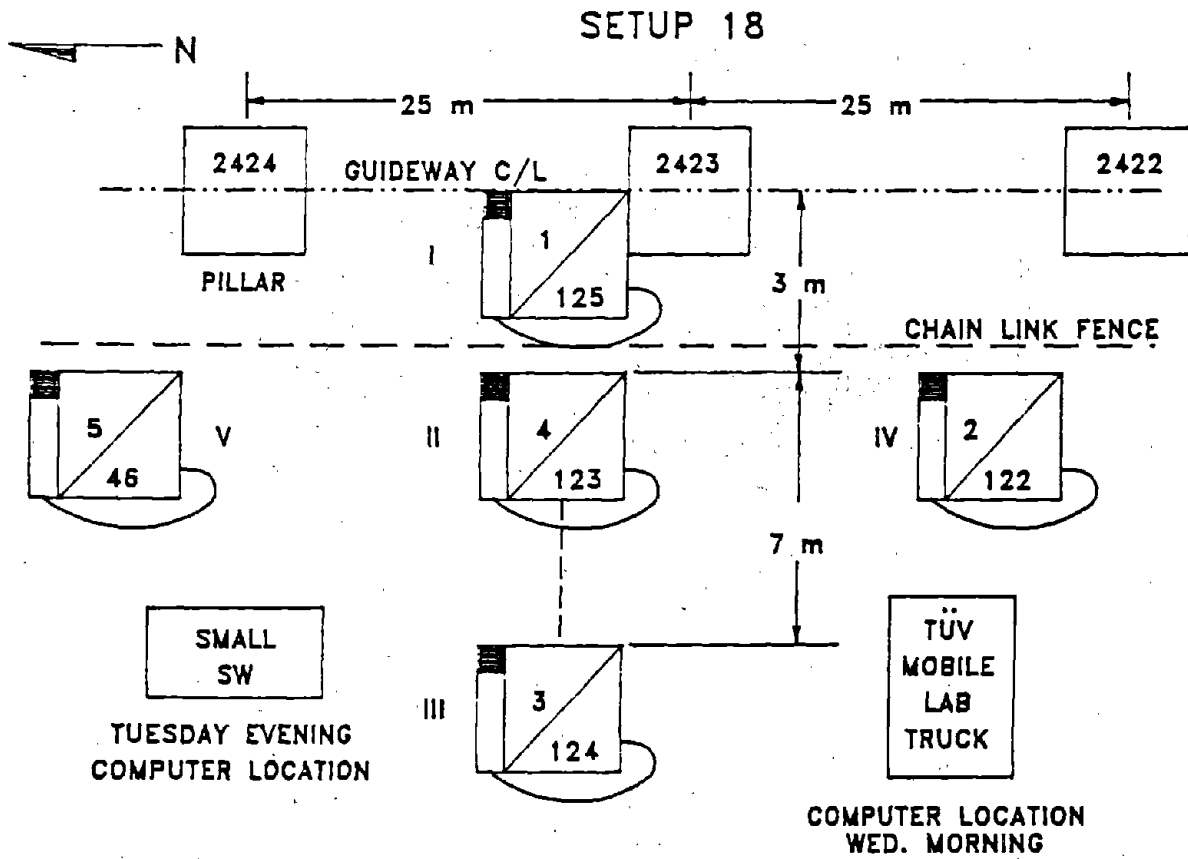

TOP VIEW OF ALL PROBE ORIENTATIONS

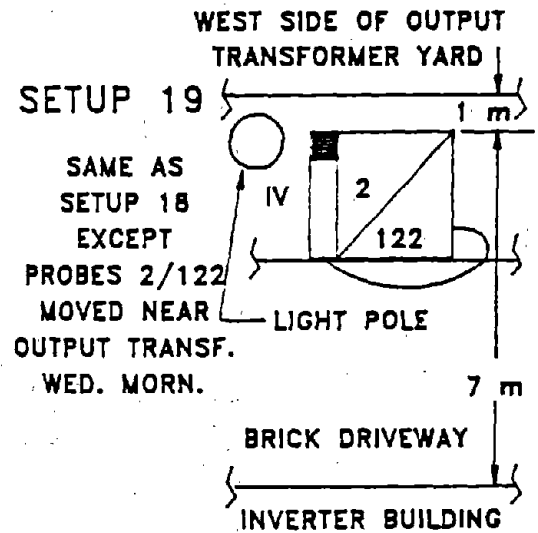
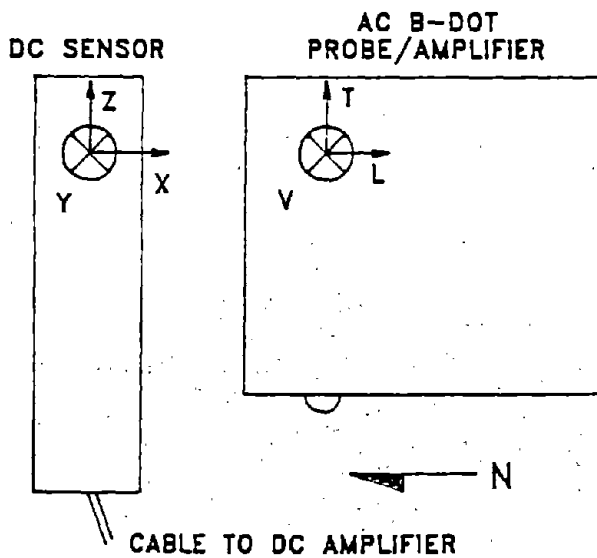

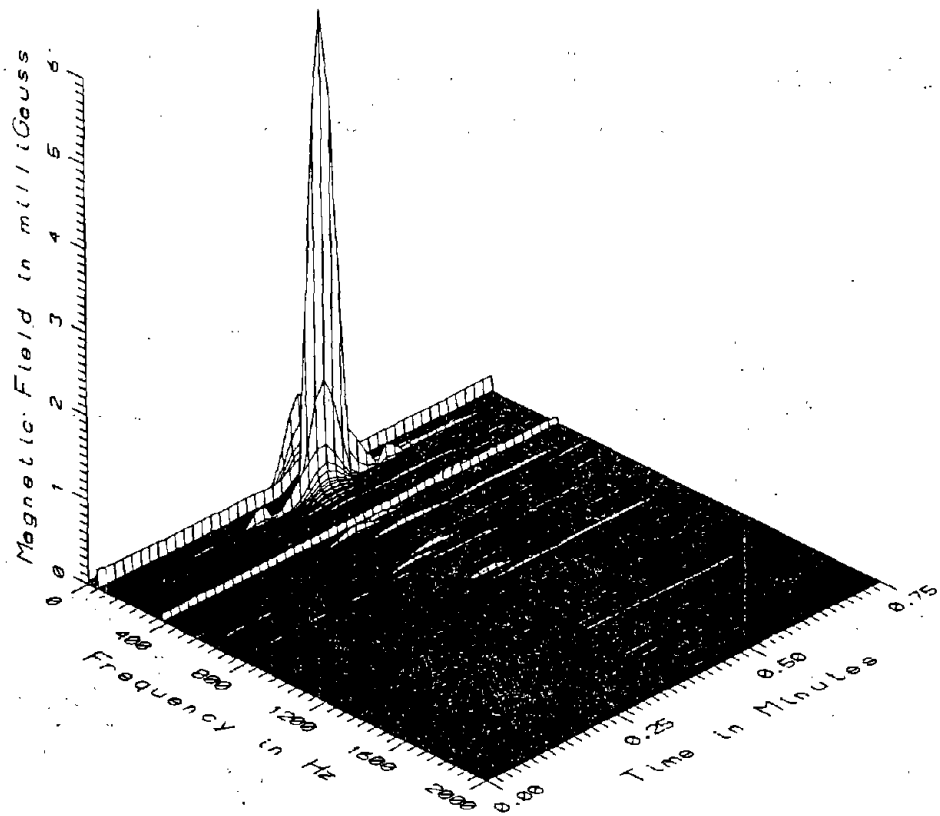

TR7017 - UNDER CENTER OF HIGH STEEL GUIDEWAY

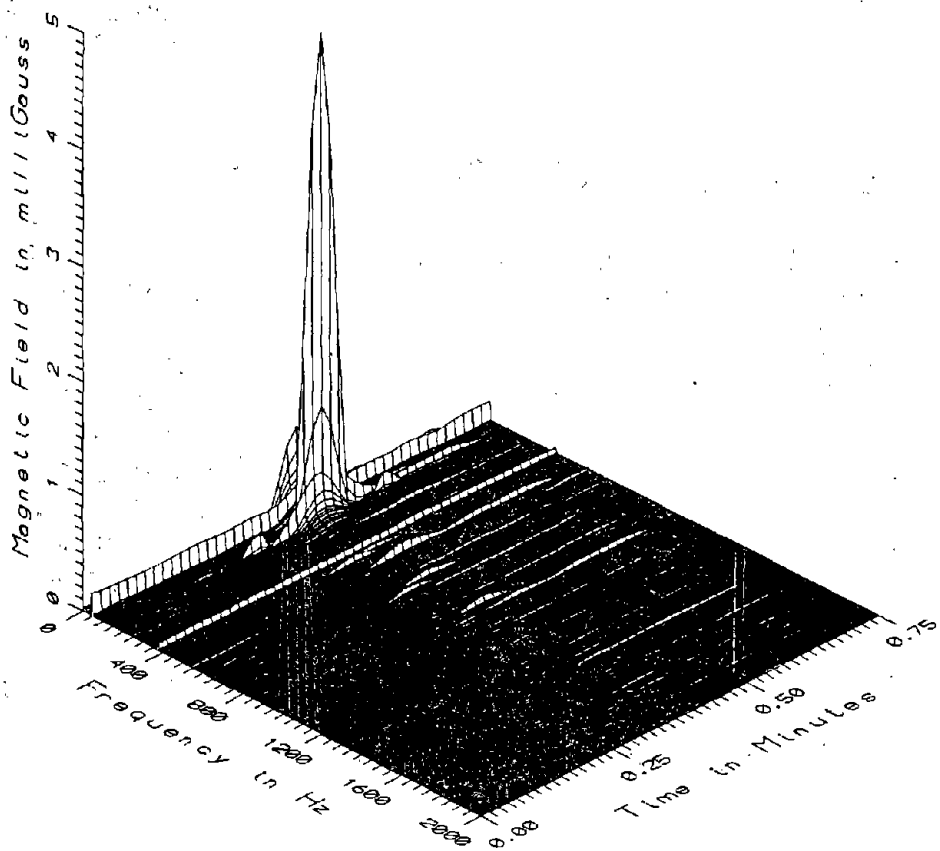

TR7017 - 3M WEST OF HIGH STEEL GUIDEWAY

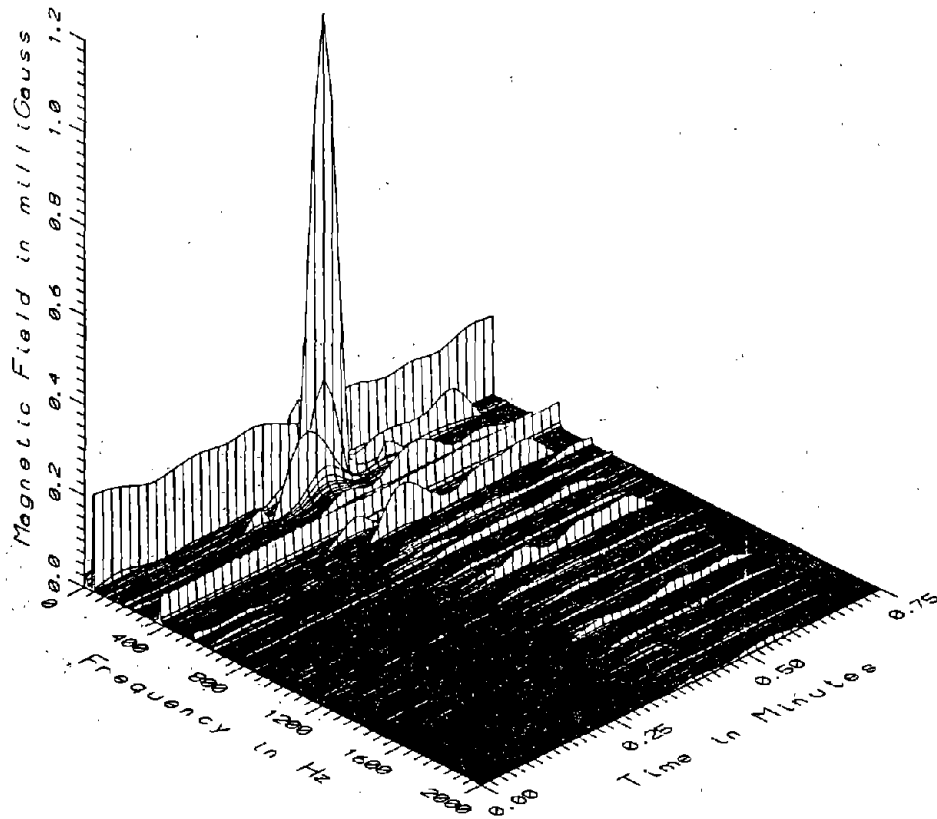

TR7017 - 10M WEST OF HIGH STEEL GUIDEWAY

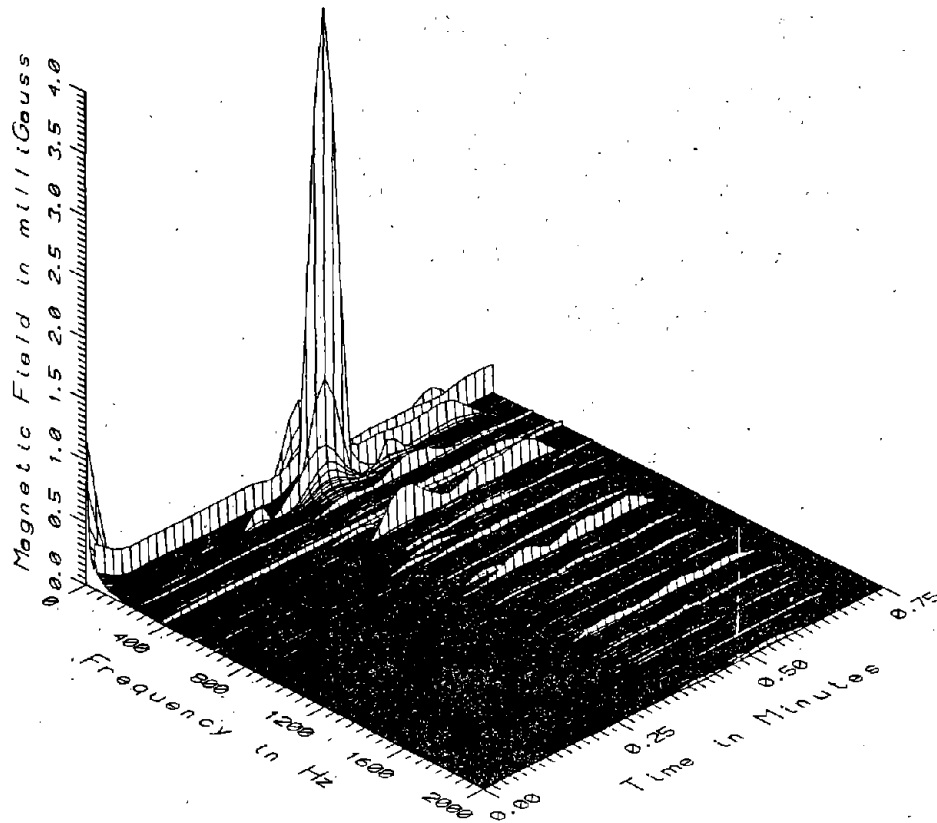

TR7017 - 3M WEST OF HIGH STEEL GUIDEWAY, 25M SOUTH OF PROFILE

M-4

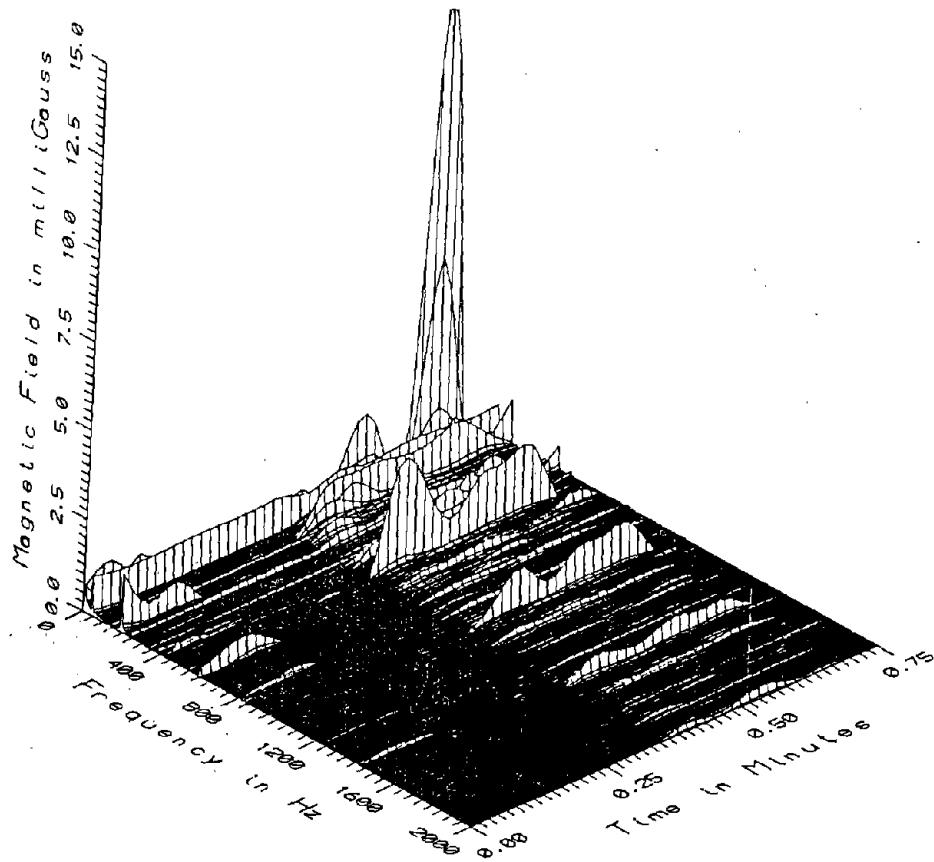

TR7017 - 3M WEST OF HIGH STEEL GUIDEWAY, 25M NORTH OF PROFILE

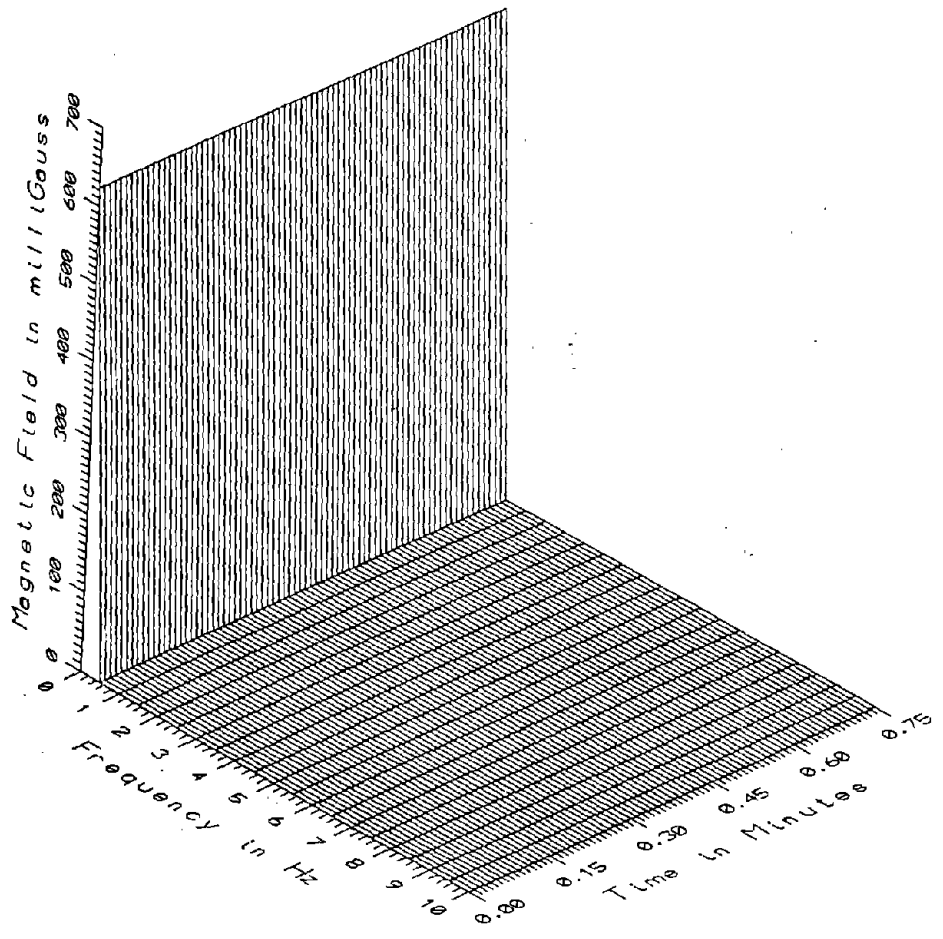

TR7017 - UNDER CENTER OF HIGH STEEL GUIDEWAY
M-5

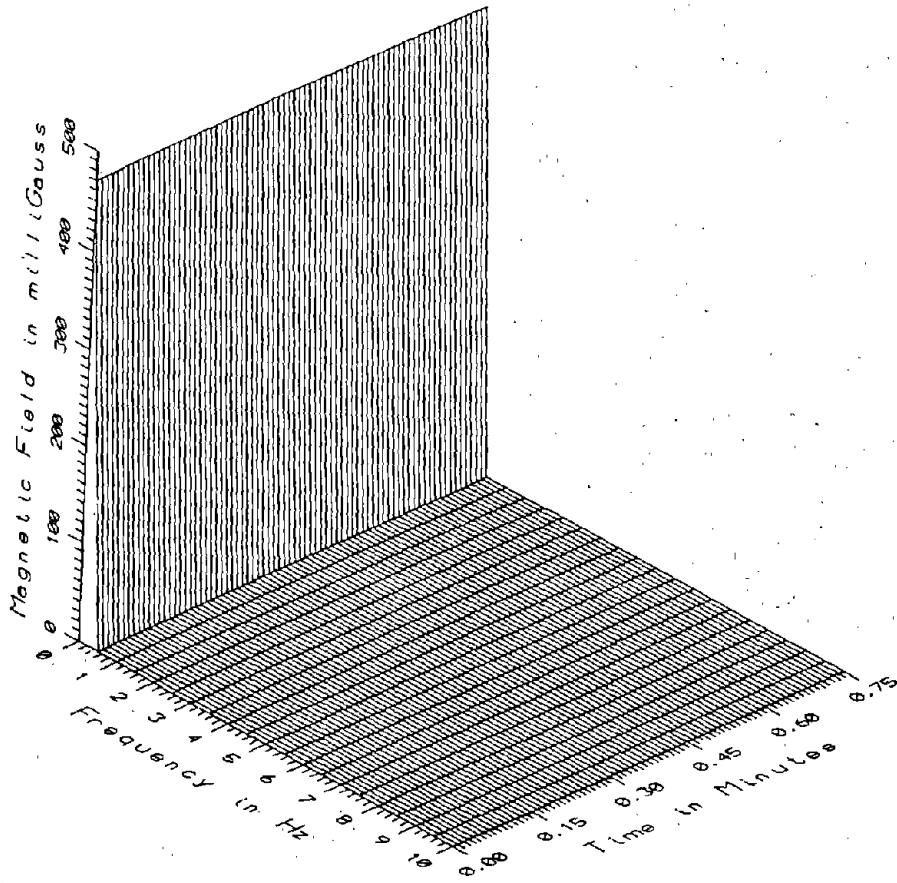

TR7017 - 3M WEST OF HIGH STEEL GUIDEWAY

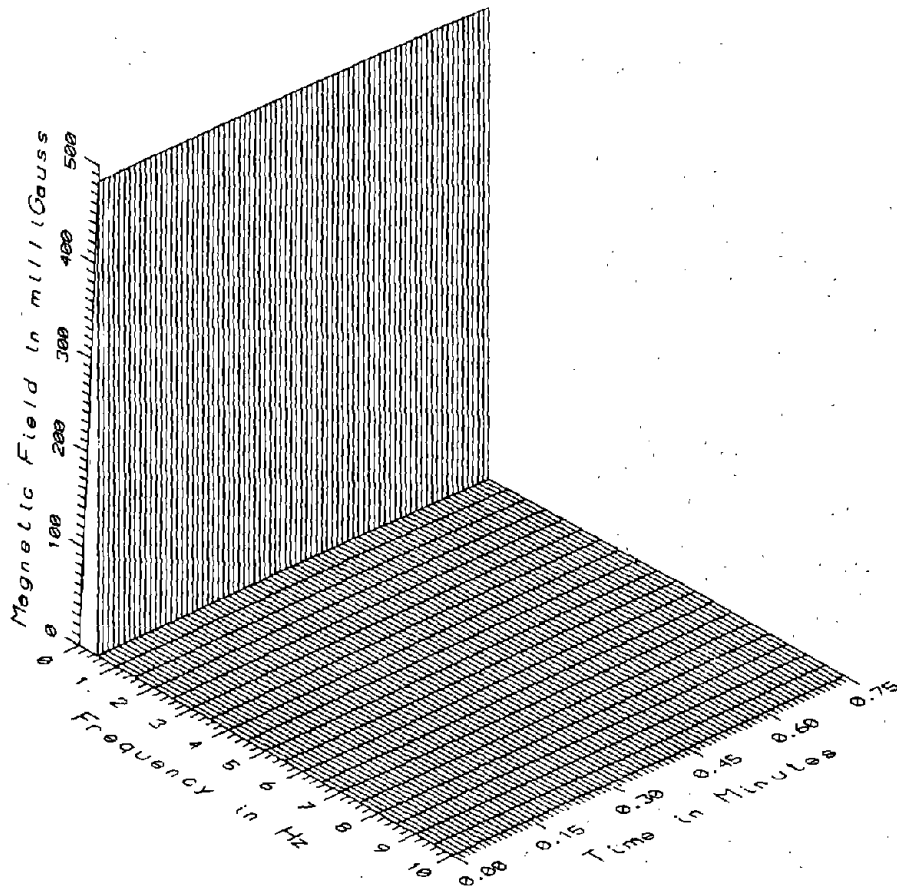

TR7017 - 10M WEST OF HIGH STEEL GUIDEWAY

M-6

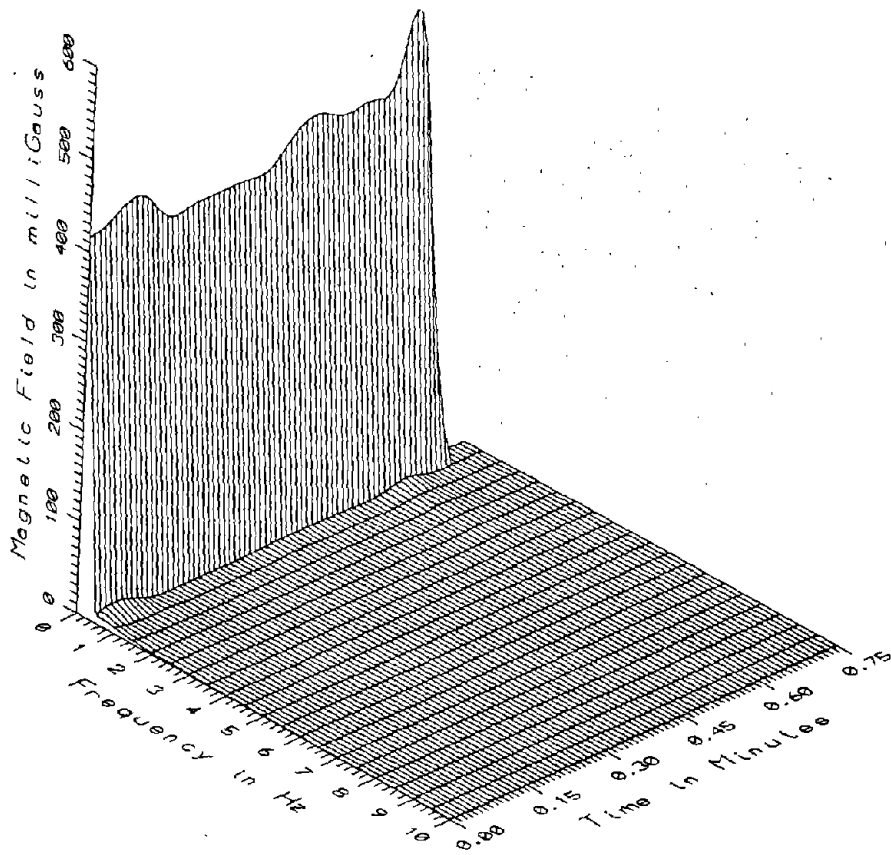

TR7017 - 3M WEST OF HIGH STEEL GUIDEWAY, 25M SOUTH OF PROFILE

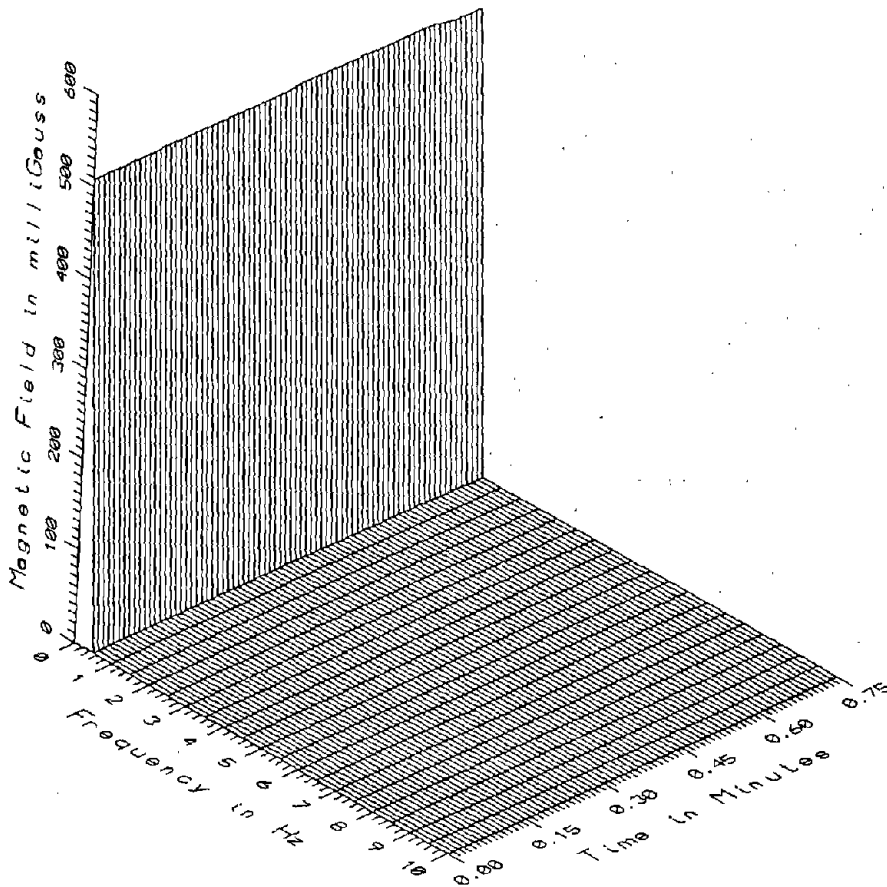

TR7017 - 3M WEST OF HIGH STEEL GUIDEWAY, 25M NORTH OF PROFILE

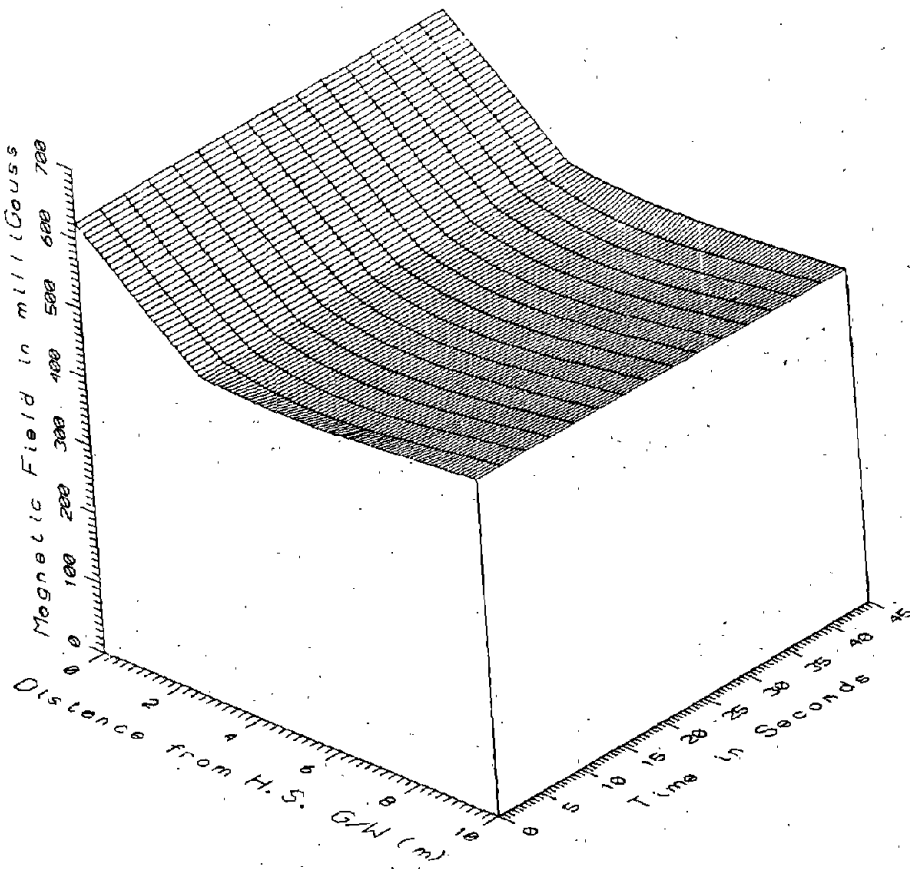

TR7017. HIGH STEEL GUIDEWAY - DC

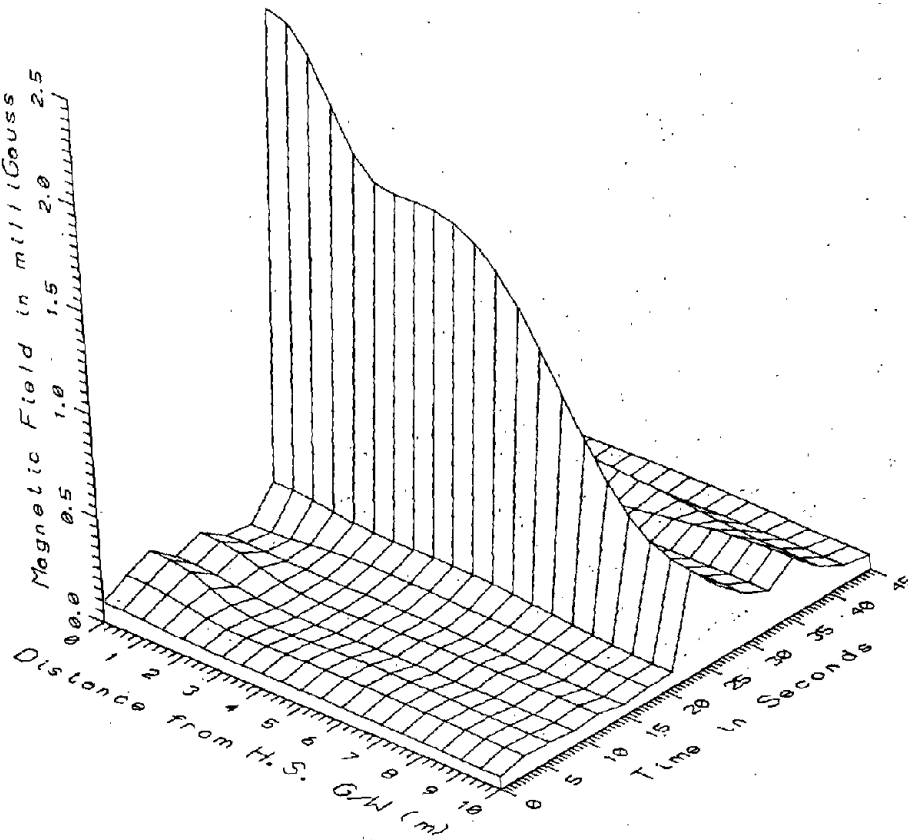

TR7017. HIGH STEEL GUIDEWAY - LOW FREQUENCY, 5-45Hz

M-8

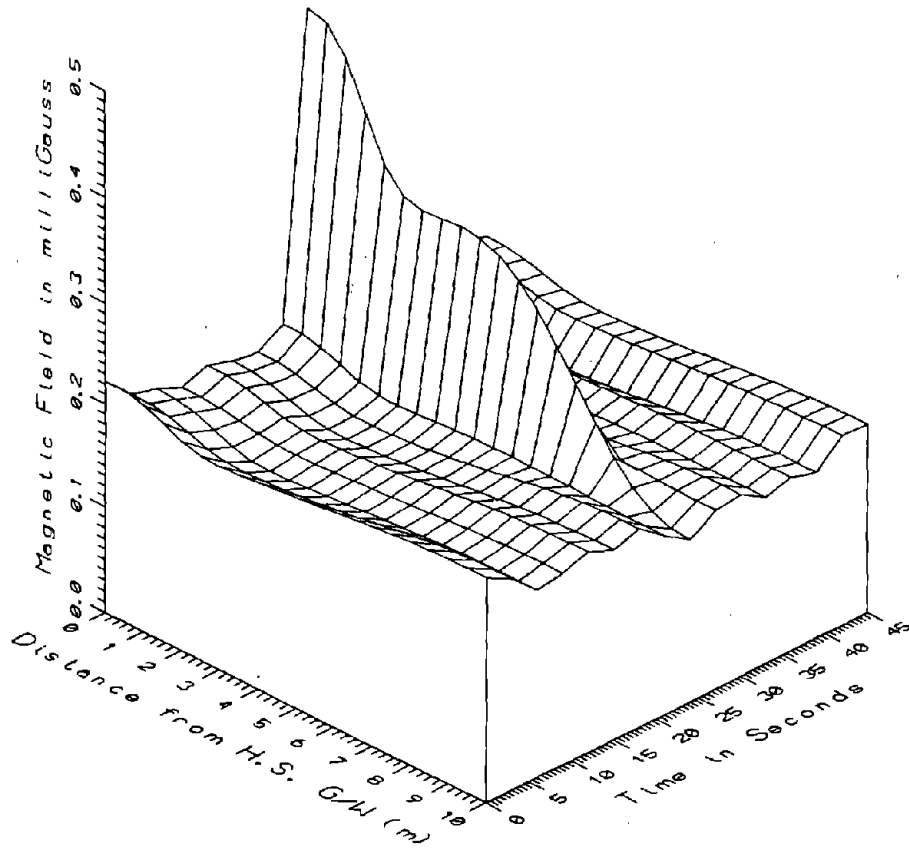

TR7017. HIGH STEEL GUIDEWAY - POWER FREQUENCY, 50-60Hz

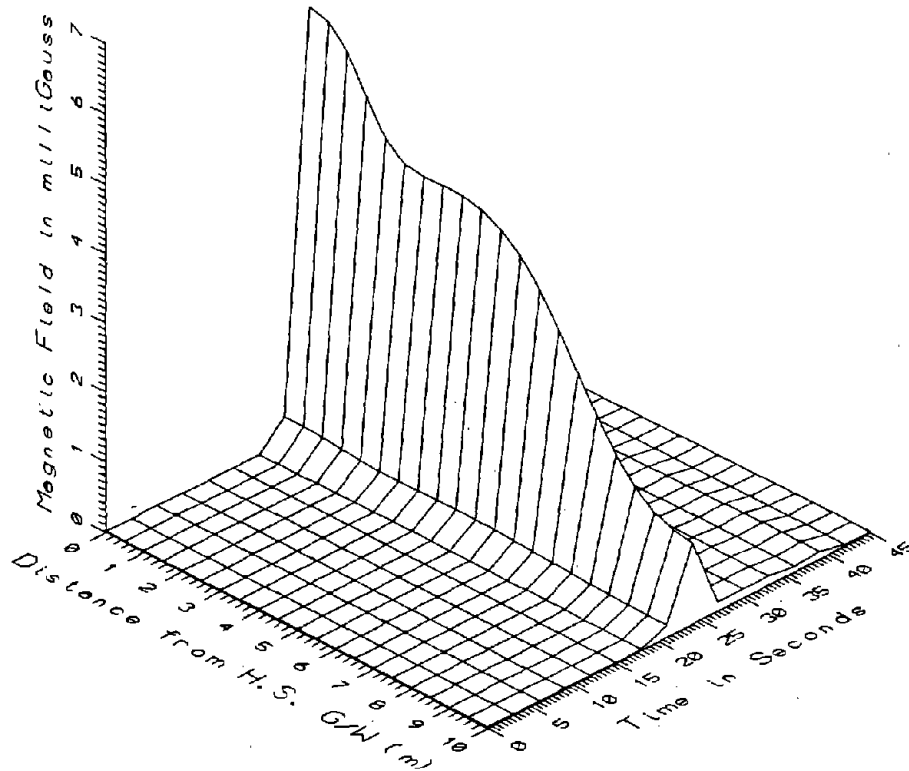

TR7017. HIGH STEEL GUIDEWAY - POWER HARMONICS, 65-300Hz

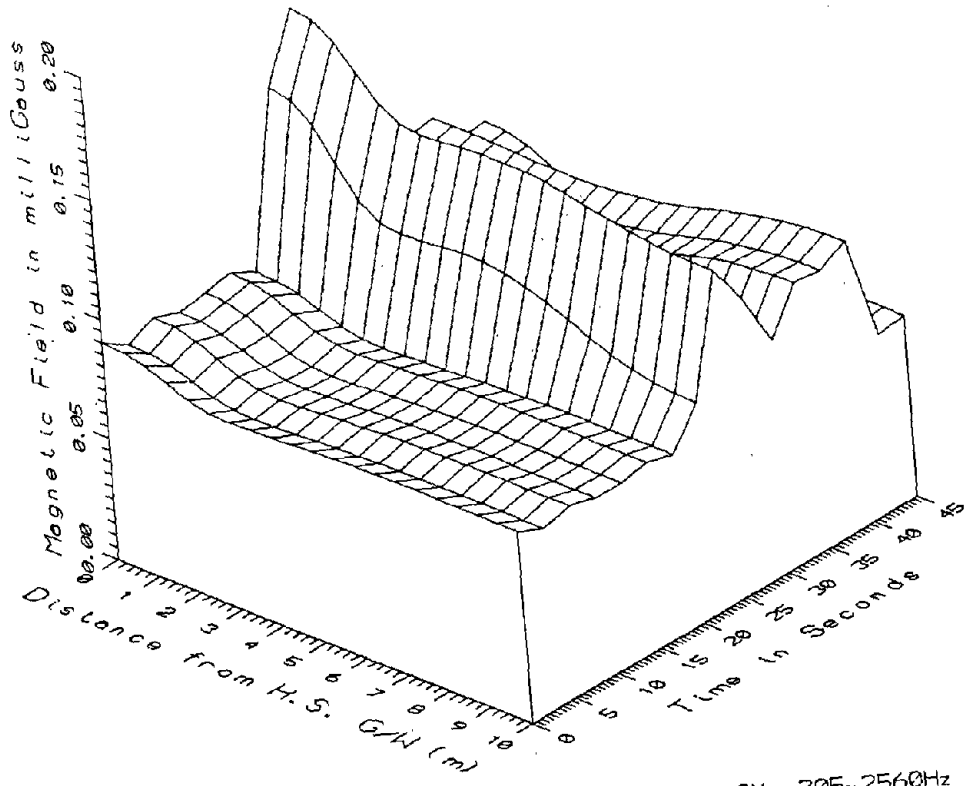

TR7017. HIGH STEEL GUIDEWAY - HIGH FREQUENCY. 305-2560Hz

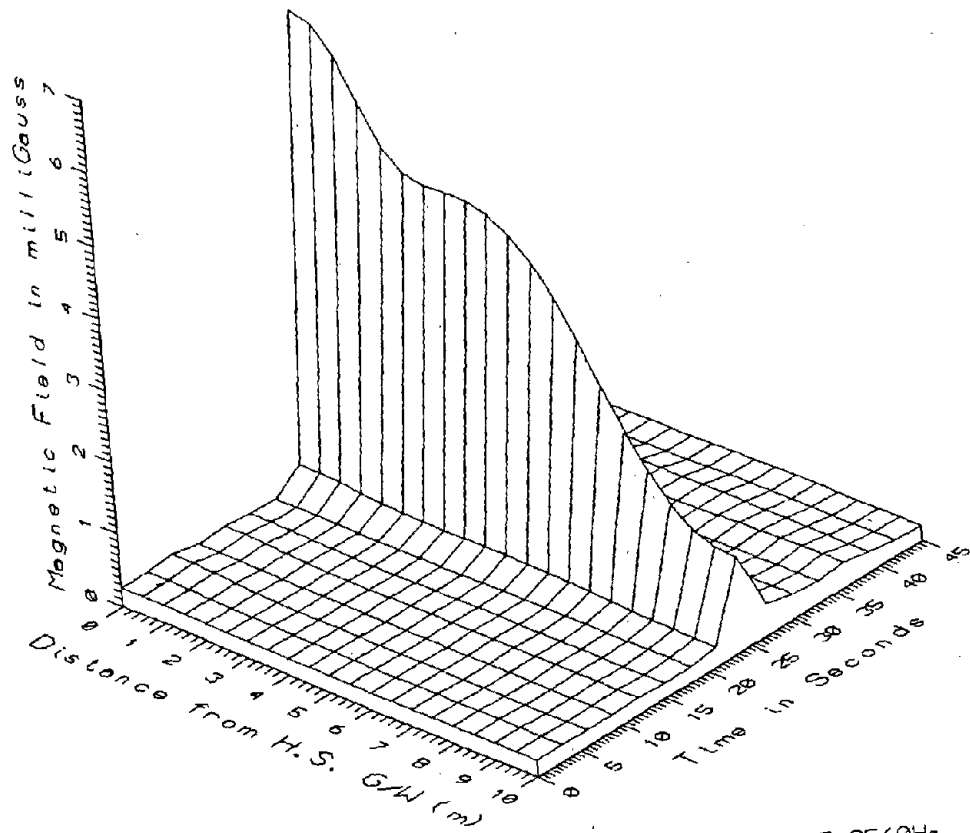

TR7017. HIGH STEEL GUIDEWAY - ALL FREQUENCIES. 5-2560Hz

M-10

N-i

APPENDIX N
DATA SET TR7018
LATERAL PROFILE
BENEATH THE HIGH STEEL GUIDEWAY

N-1

APPENDIX N

DATA SET TR7018
LATERAL PROFILE BENEATH THE HIGH STEEL GUIDEWAY

Measurement Setup Code: 19
Vehicle Status: Running on other part of guideway
Measurement Date: August 8, 1990
Measurement Time: Start: 12:56:00
End: 13:01:06
Number of Samples: 52
Programmed Sample Interval: 3 sec
Actual Sample Interval: 6 sec

Frequency Spectrum Parameters

<u>Probe Type:</u>	<u>Coil (AC)</u>	<u>Fluxgate (DC)</u>
Maximum Frequency (Hz)	2560	256
Minimum Frequency (Hz)	5	0
Spectral Bandwidth (Hz)	5	0.5

Missing or Suspect Data: The fluxgate probe between the inverter building and transformer yard was not connected.

SETUP 18, 19: HIGH STEEL GUIDEWAY, PILLAR 2423 NEAR CONTROL CENTER

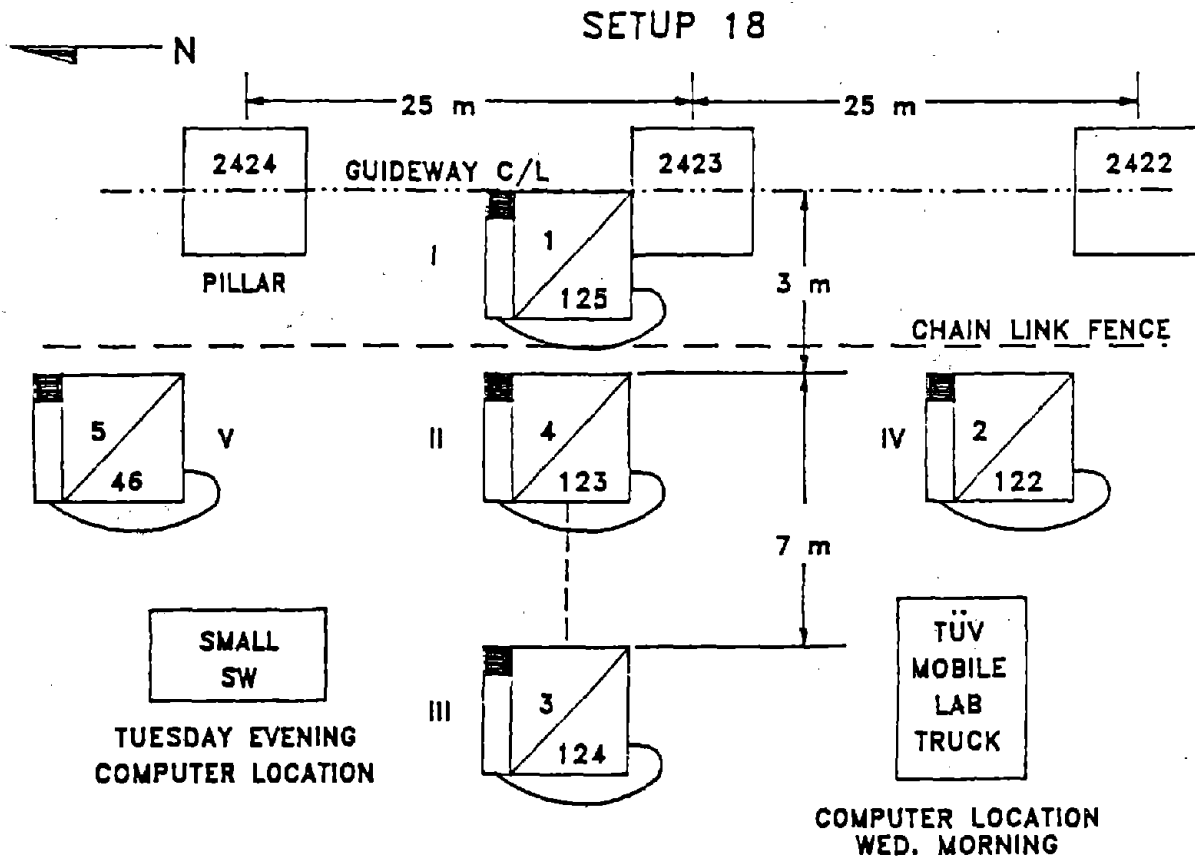

TOP VIEW OF ALL PROBE ORIENTATIONS

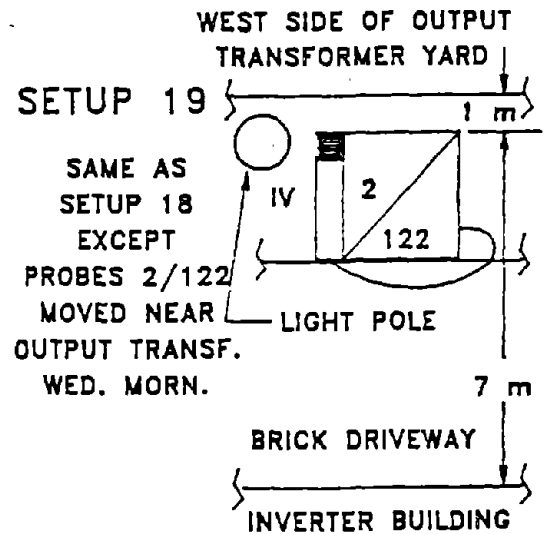
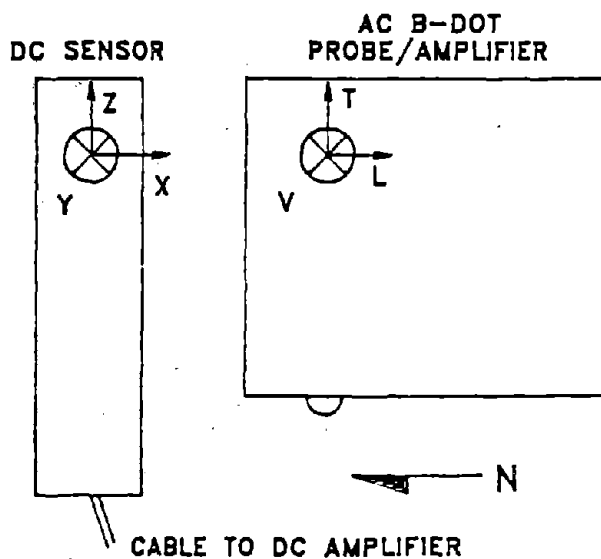

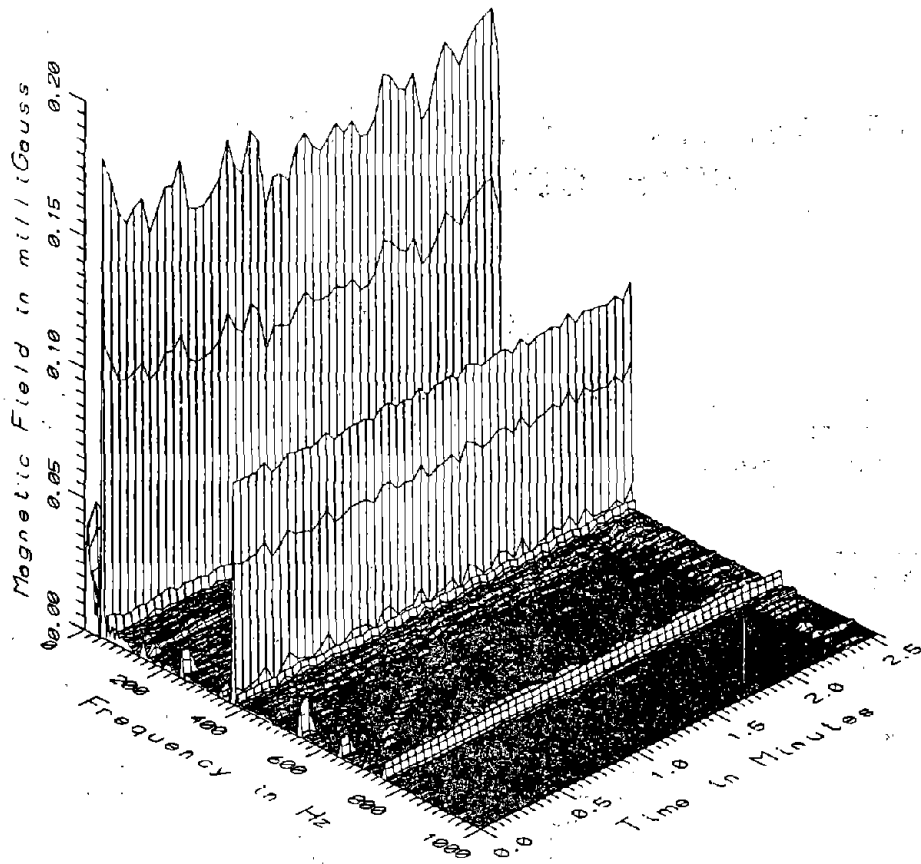

TR7018 - UNDER CENTER OF HIGH STEEL GUIDEWAY

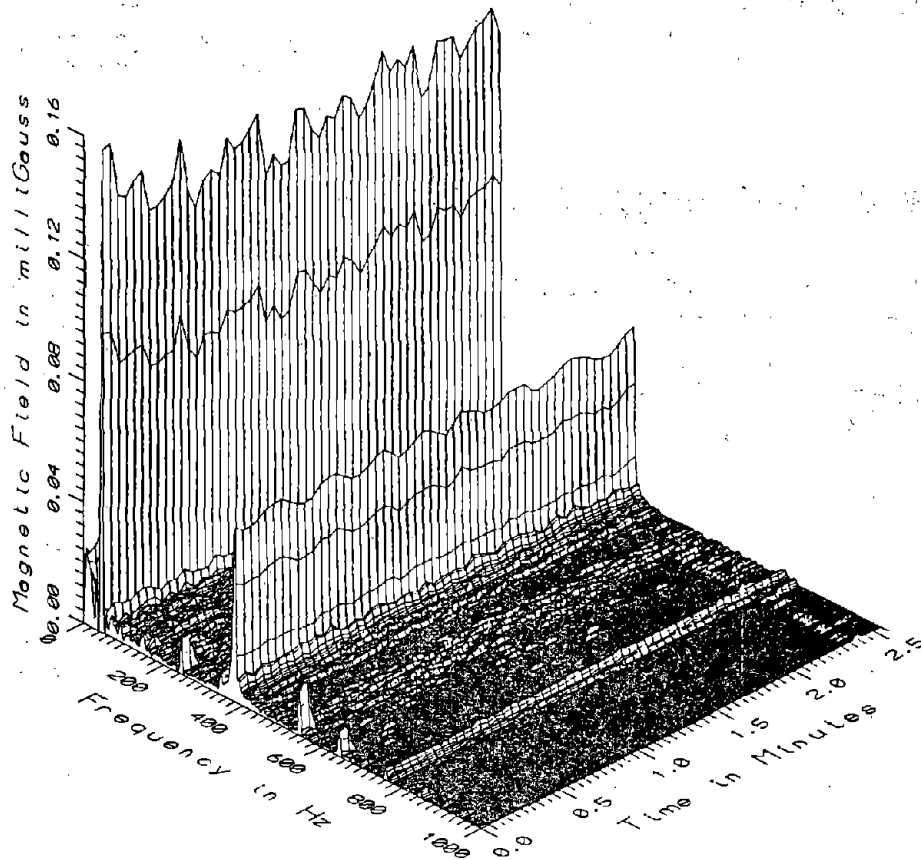

TR7018 - 3M WEST OF HIGH STEEL GUIDEWAY

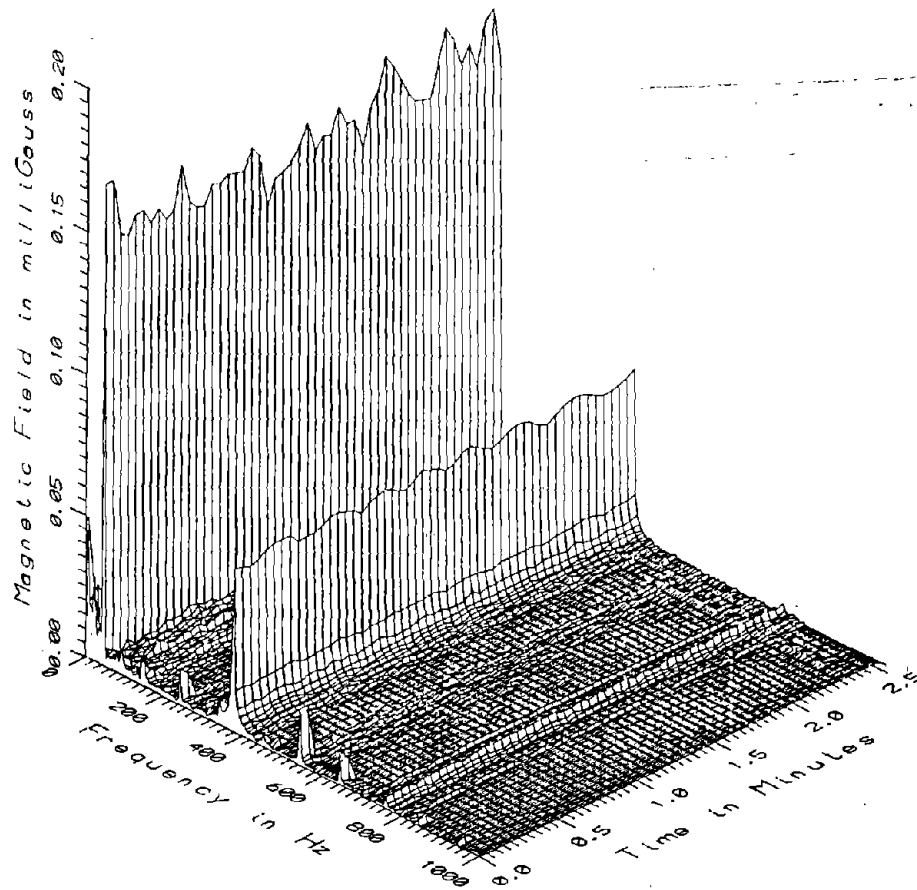

TR7018 - 10M WEST OF HIGH STEEL GUIDEWAY

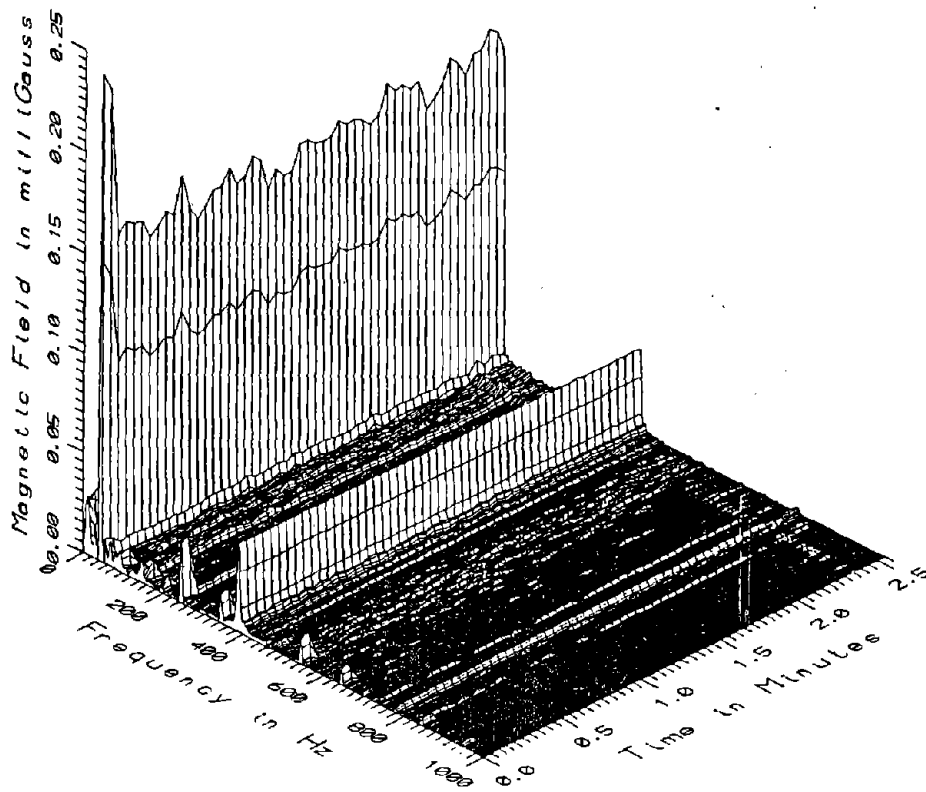

TR7018 - 3M WEST OF HIGH STEEL GUIDEWAY, 25M NORTH OF PROFILE

N-4

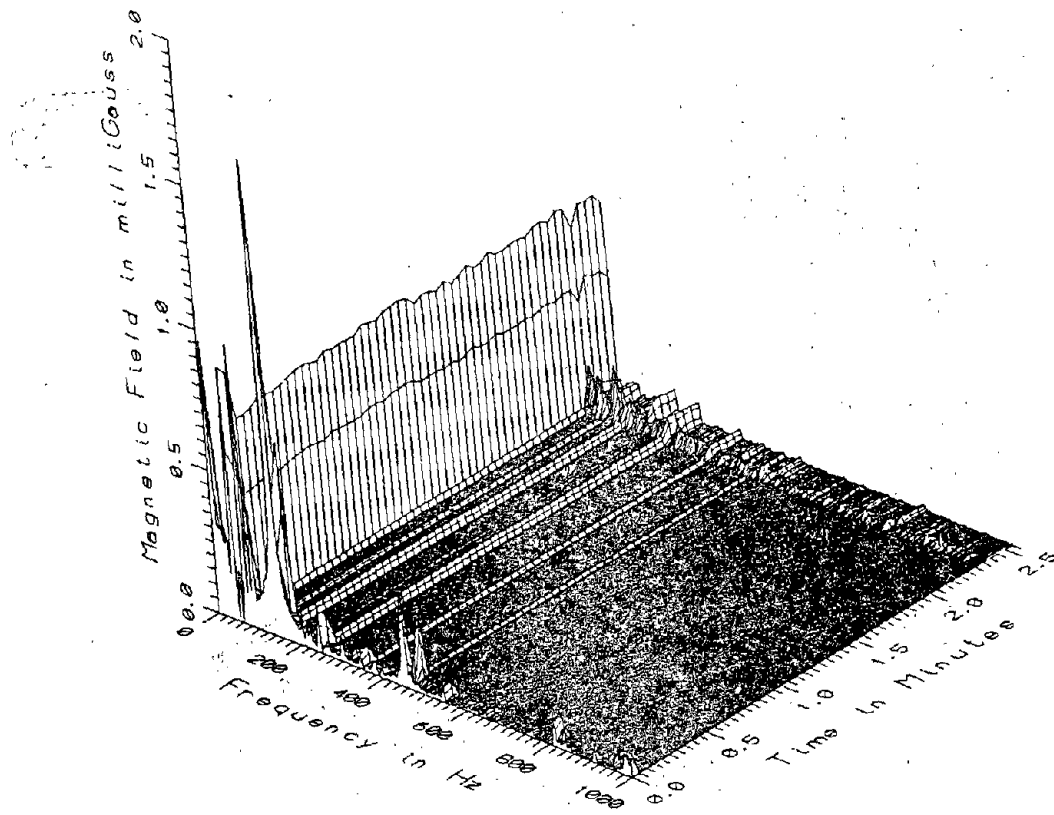

TR701B - 1M WEST OF OUTPUT TRANSFORMER YARD AND 7M EAST OF INVERTER BUILDING

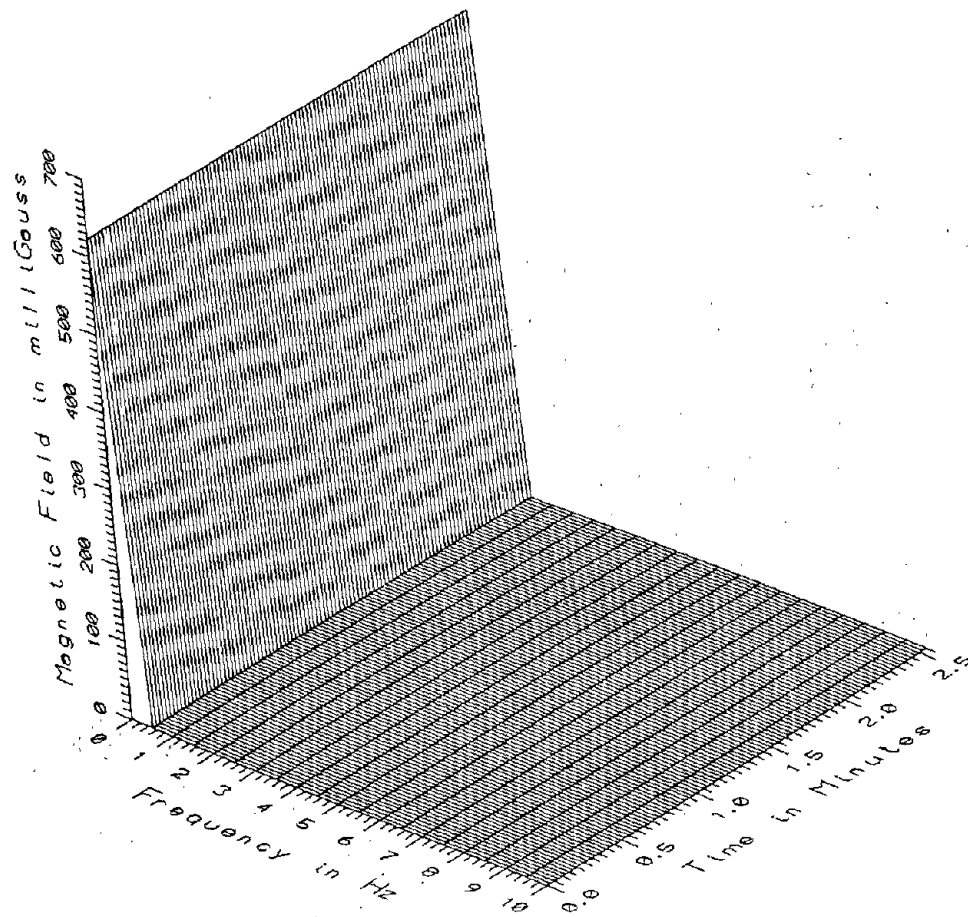

TR701B - UNDER CENTER OF HIGH STEEL GUIDEWAY

N-5

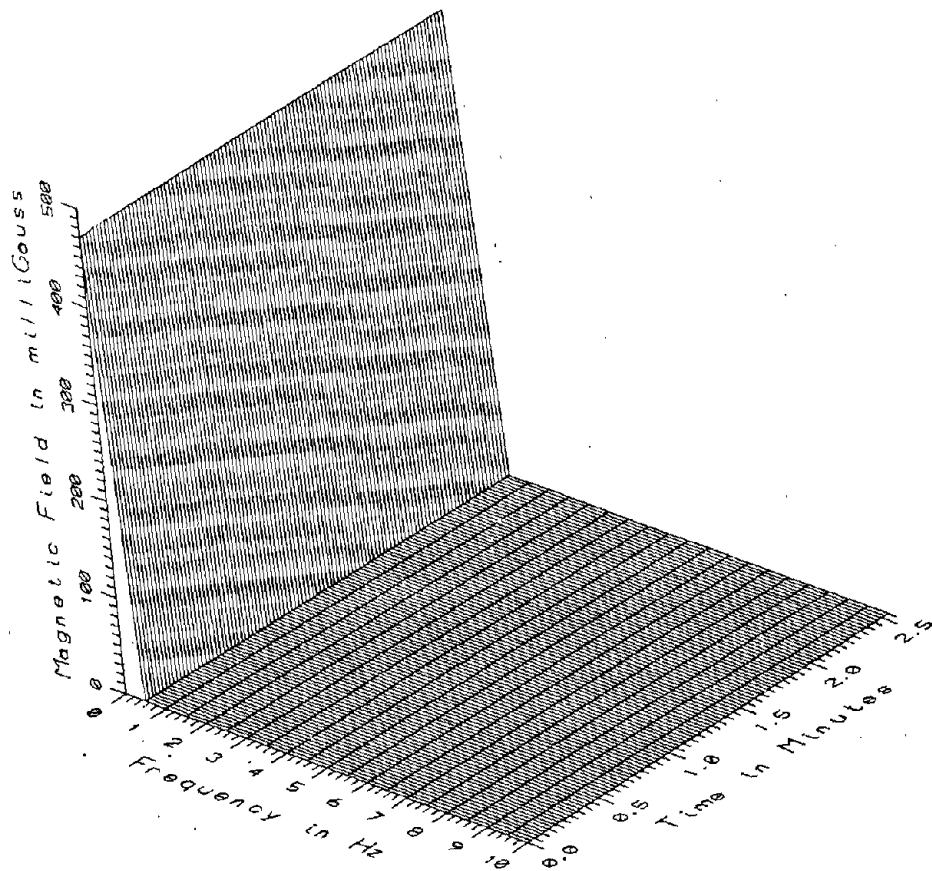

TR7018 - 3M WEST OF HIGH STEEL GUIDEWAY

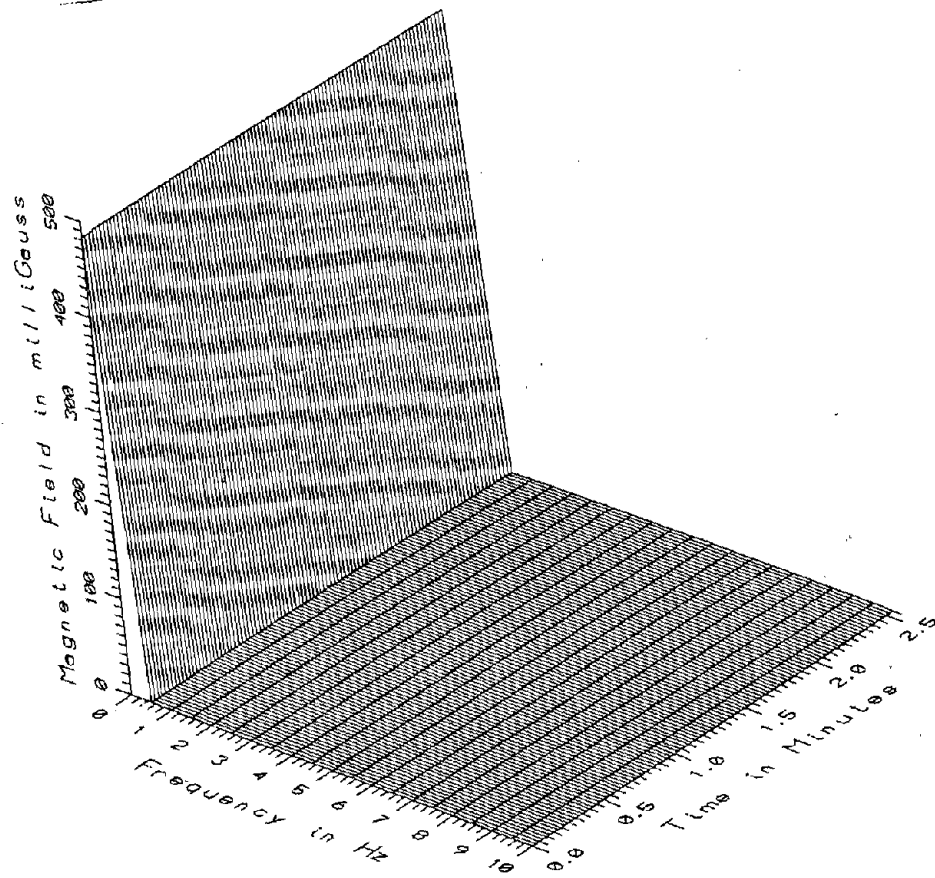

TR7018 - 10M WEST OF HIGH STEEL GUIDEWAY

N-6

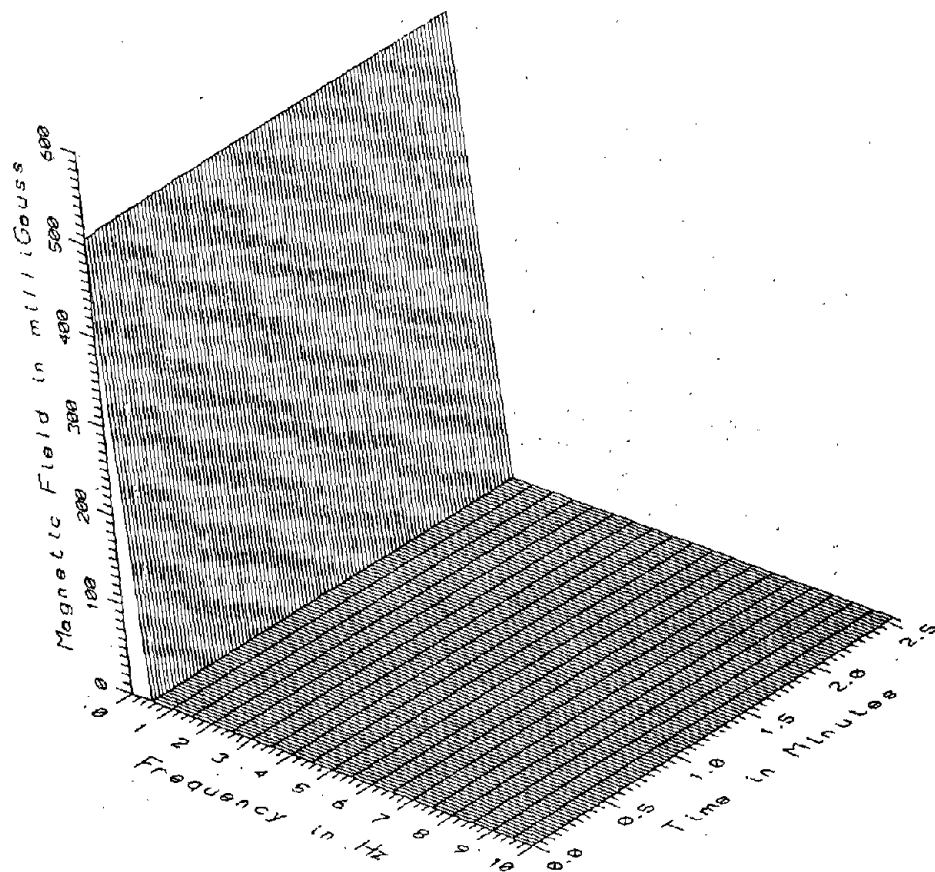

TR018 - 3M WEST OF HIGH STEEL GUIDEWAY, 25M NORTH OF PROFILE

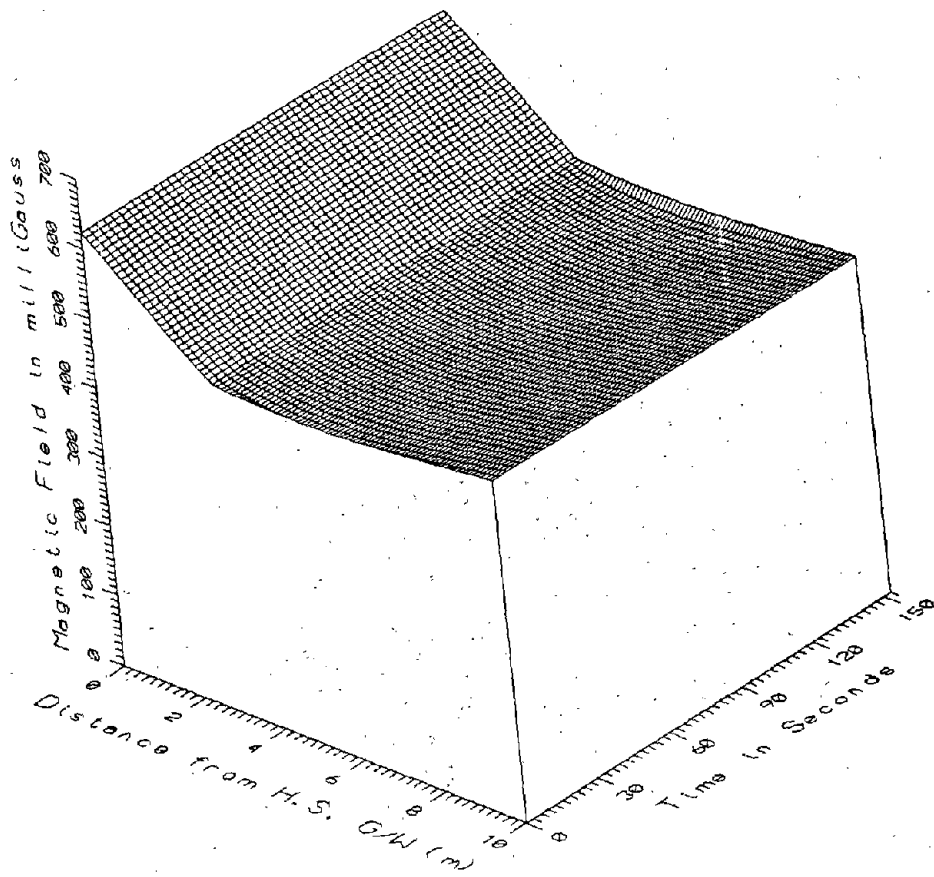

TR018, HIGH STEEL GUIDEWAY - DC

N-7

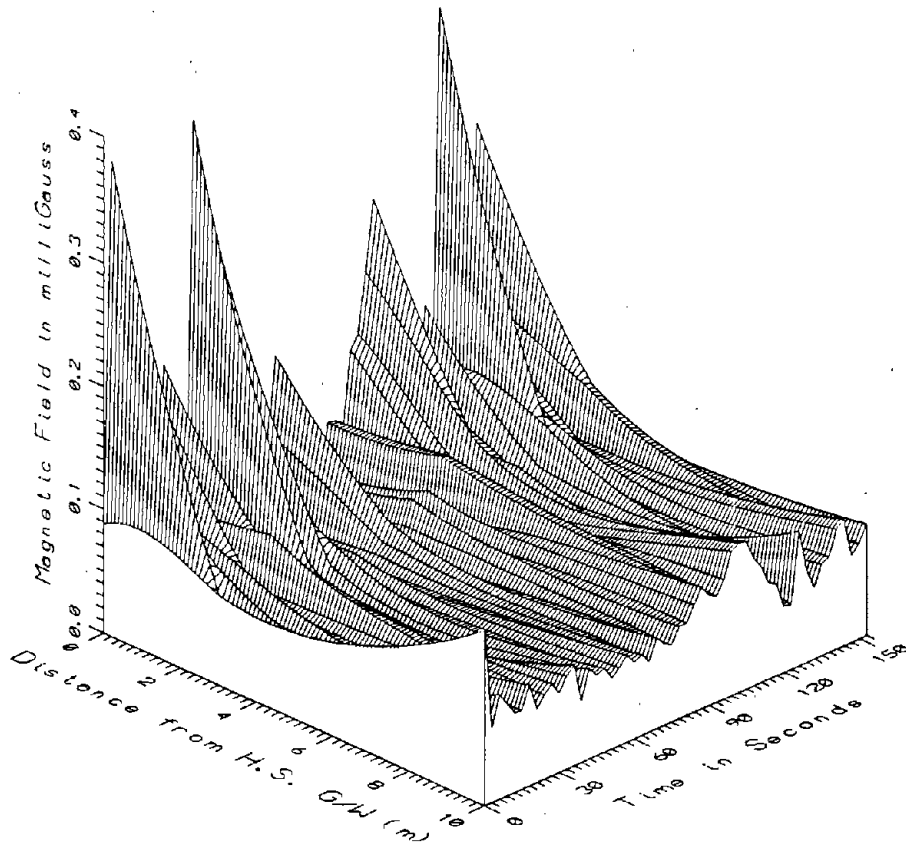

TR7018, HIGH STEEL GUIDEWAY - LOW FREQUENCY, 5-45Hz

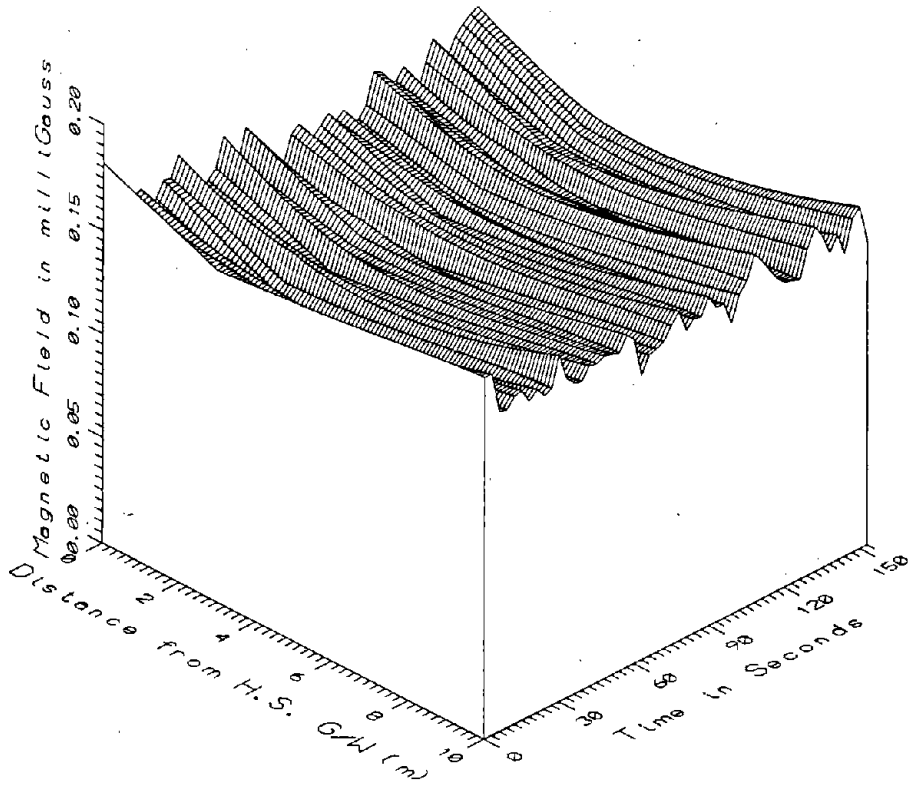

TR7018, HIGH STEEL GUIDEWAY - POWER FREQUENCY, 50-60Hz

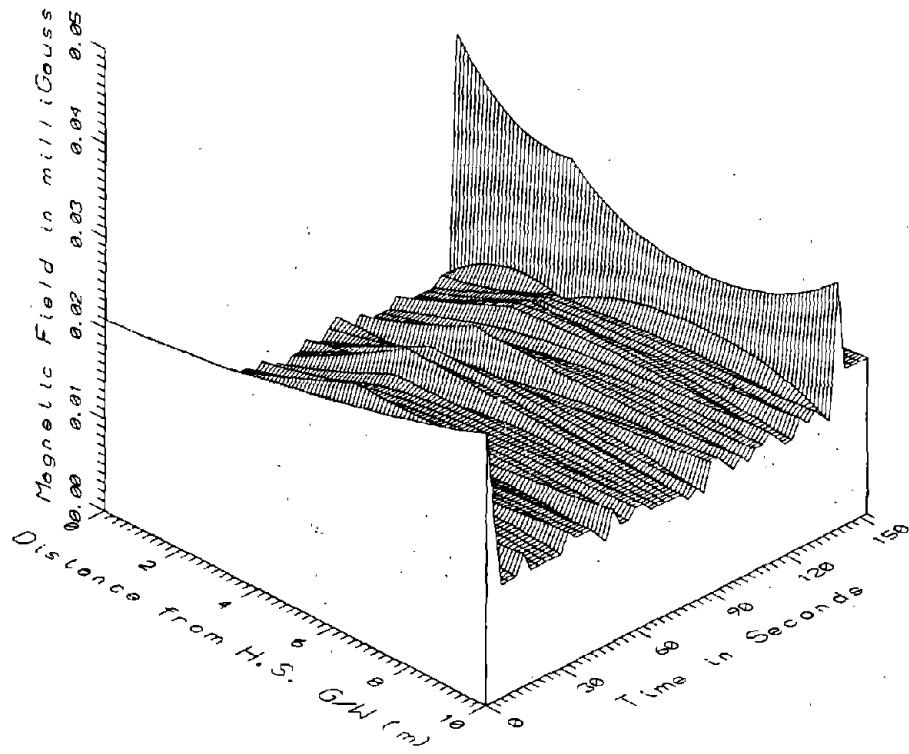

TR701B, HIGH STEEL GUIDEWAY - POWER HARMONICS, 65-300Hz

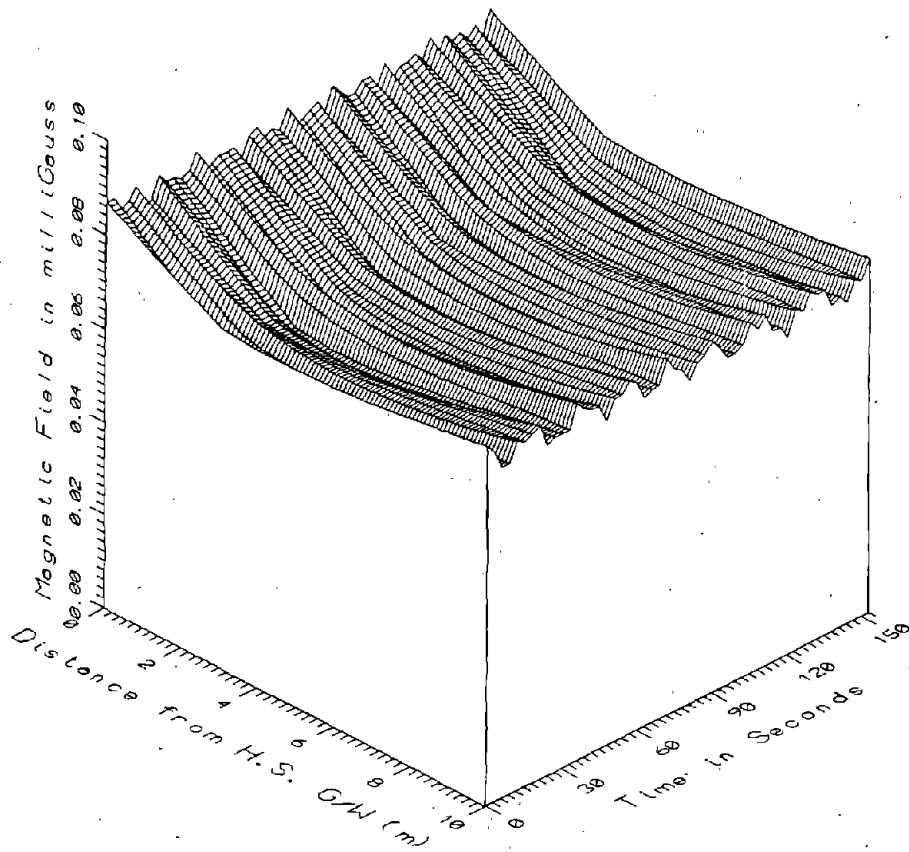

TR701B, HIGH STEEL GUIDEWAY - HIGH FREQUENCY, 305-2560Hz

N-10

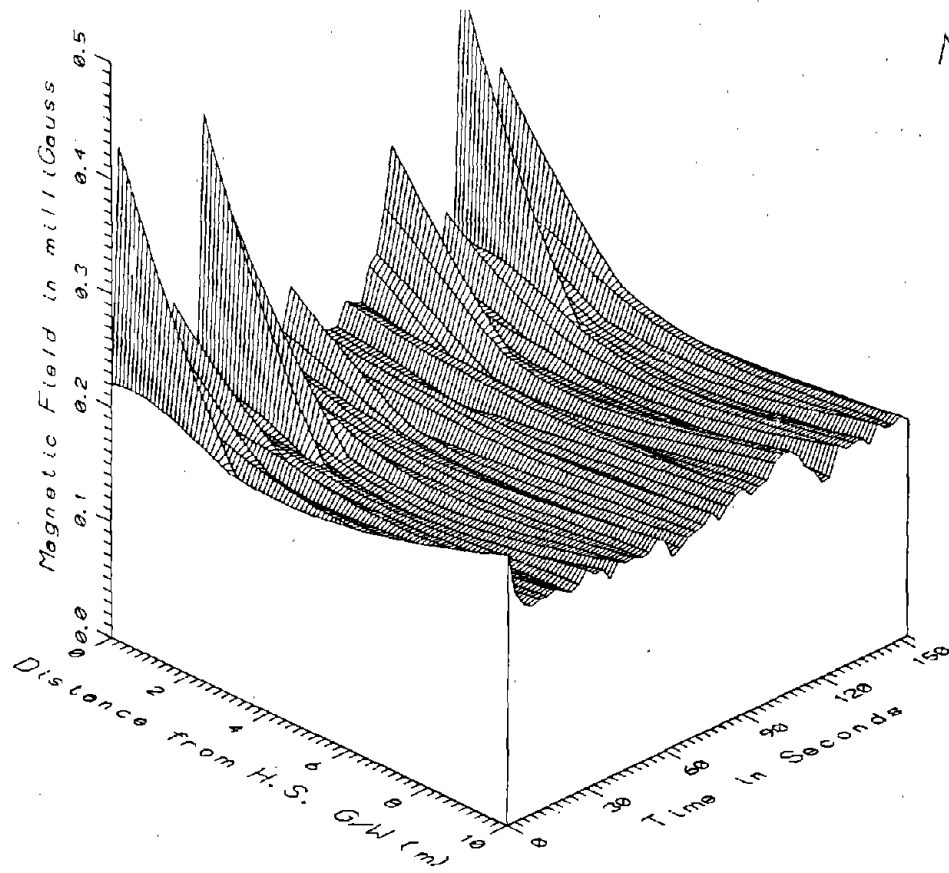

TR7018, HIGH STEEL GUIDEWAY - ALL FREQUENCIES, 5-2560Hz

0-1

APPENDIX O
DATA SET TR7019
LATERAL PROFILE
BENEATH THE LOW CONCRETE GUIDEWAY

5-1

APPENDIX O

DATA SET TR7019
LATERAL PROFILE BENEATH THE LOW CONCRETE GUIDEWAY

Measurement Setup Code: 20
Vehicle Status: Running continuously
Measurement Date: August 8, 1990
Measurement Time: Start: 16:00:00
End: 16:20:04
Number of Samples: 194
Programmed Sample Interval: 4 sec
Actual Sample Interval: 6.2 sec

Frequency Spectrum Parameters

<u>Probe Type:</u>	<u>Coil (AC)</u>	<u>Fluxgate (DC)</u>
Maximum Frequency (Hz)	2560	256
Minimum Frequency (Hz)	5	0
Spectral Bandwidth (Hz)	5	0.5

Missing or Suspect Data: None

SETUP 20: LOW CONCRETE GUIDEWAY IN SOUTH LOOP

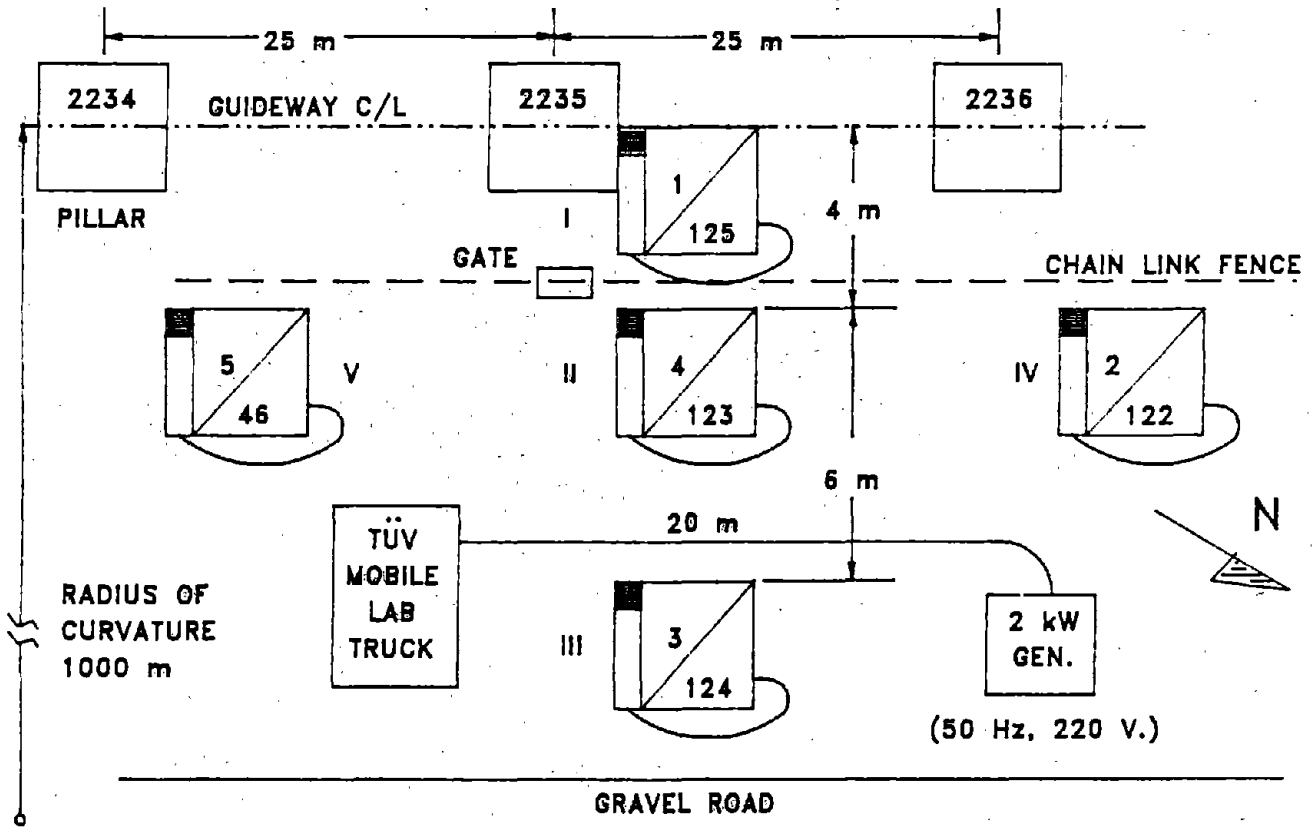

TOP VIEW OF ALL PROBE ORIENTATIONS

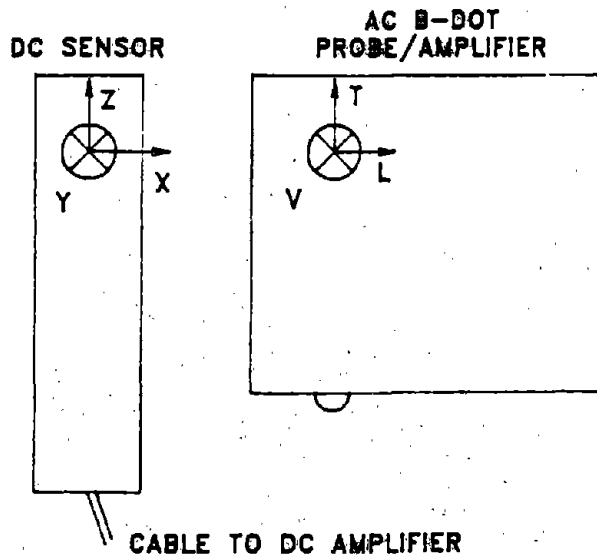

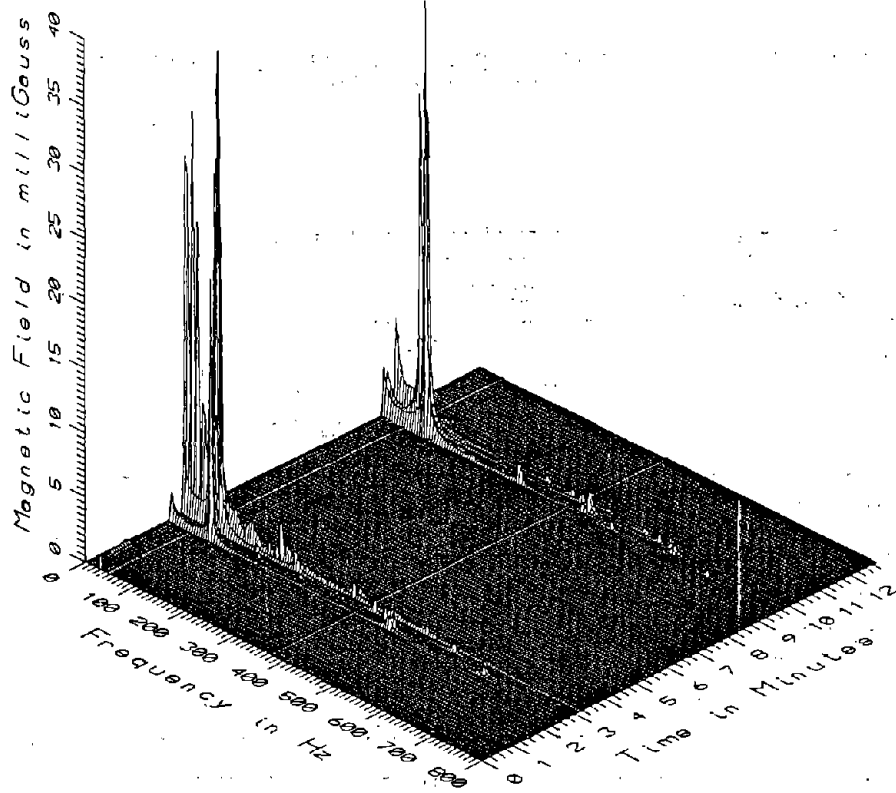

TR7019 - UNDER CENTER OF LOW CONCRETE G/W IN SOUTH LOOP

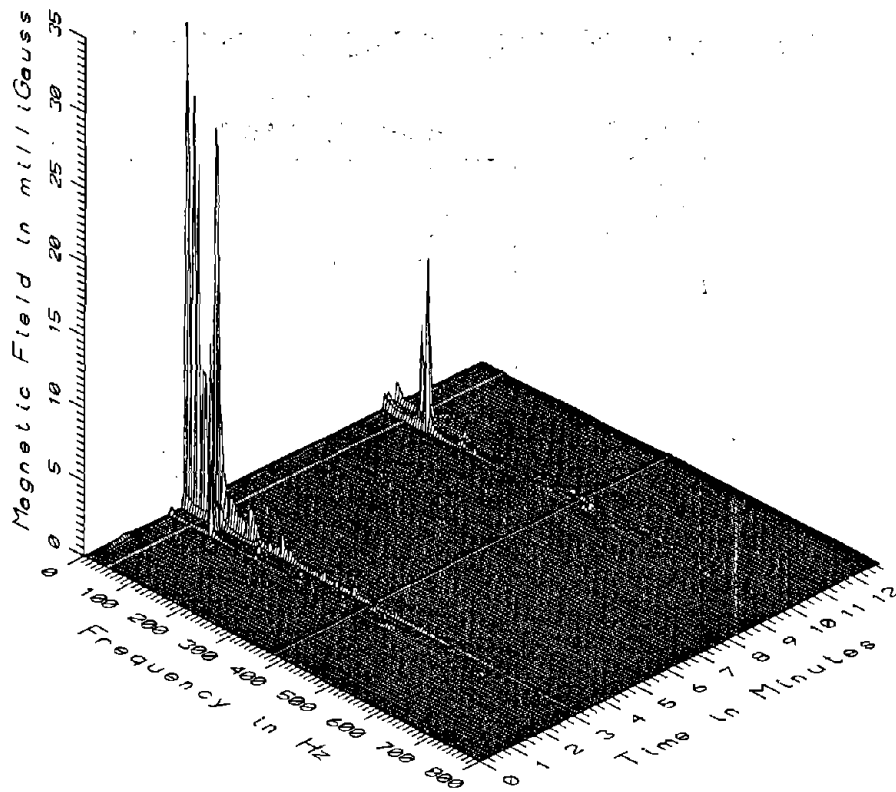

TR7019 - 4M NE OF LOW CONCRETE G/W IN SOUTH LOOP

0-3

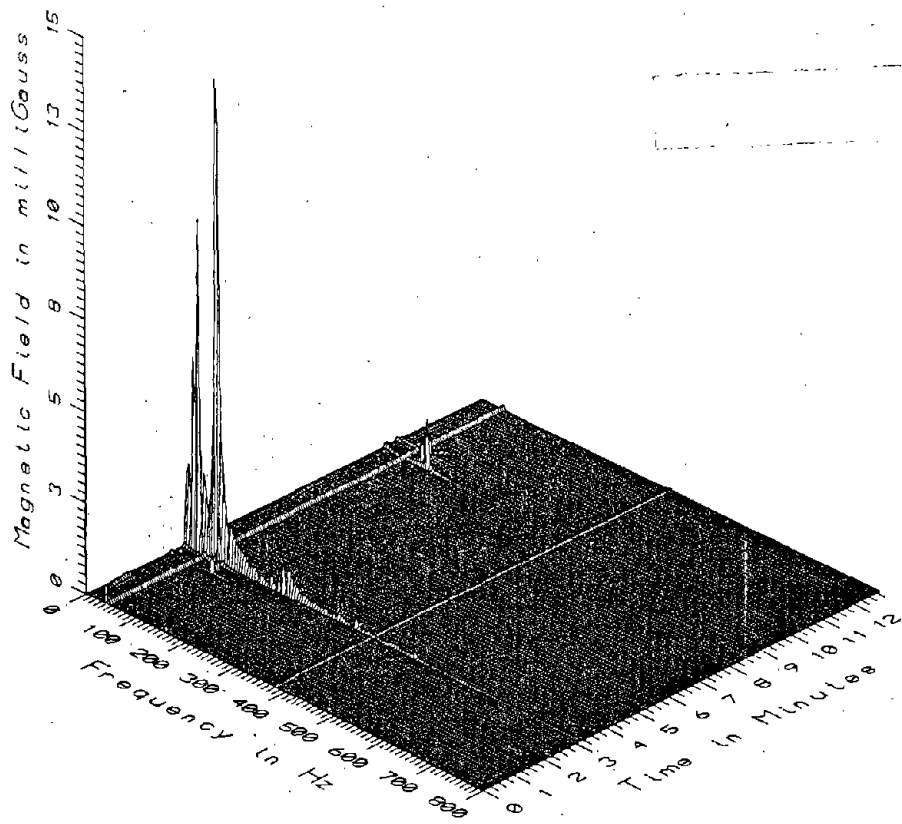

TR7019 - 10M NE OF LOW CONCRETE G/W IN SOUTH LOOP

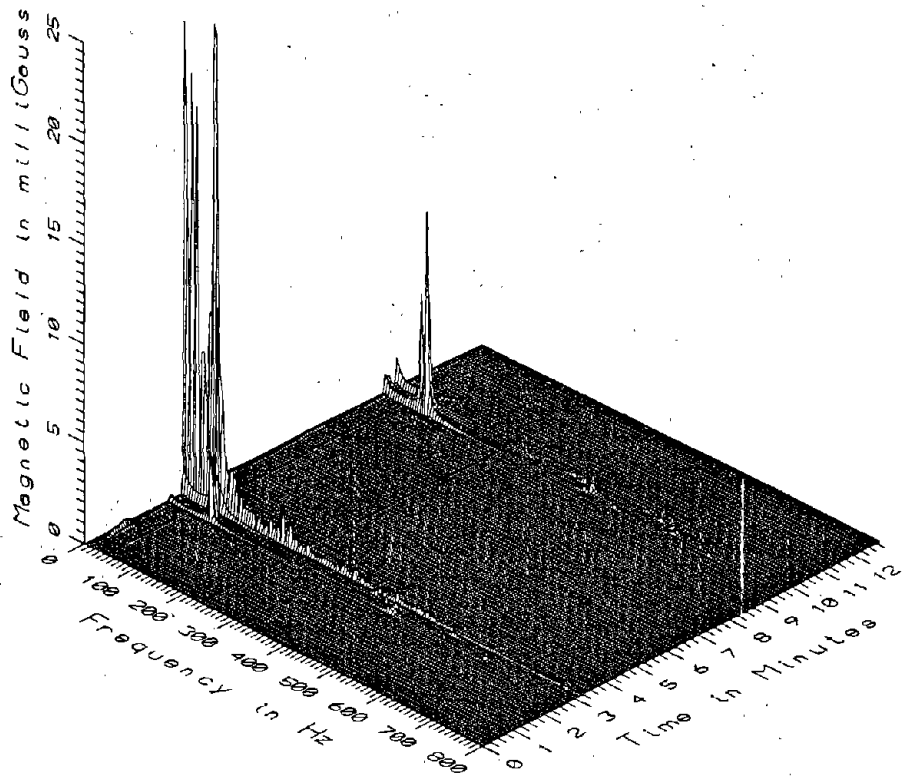

TR7019 - 4M NE OF LOW CONCRETE G/W IN SOUTH LOOP, 25M SE OF PROFILE

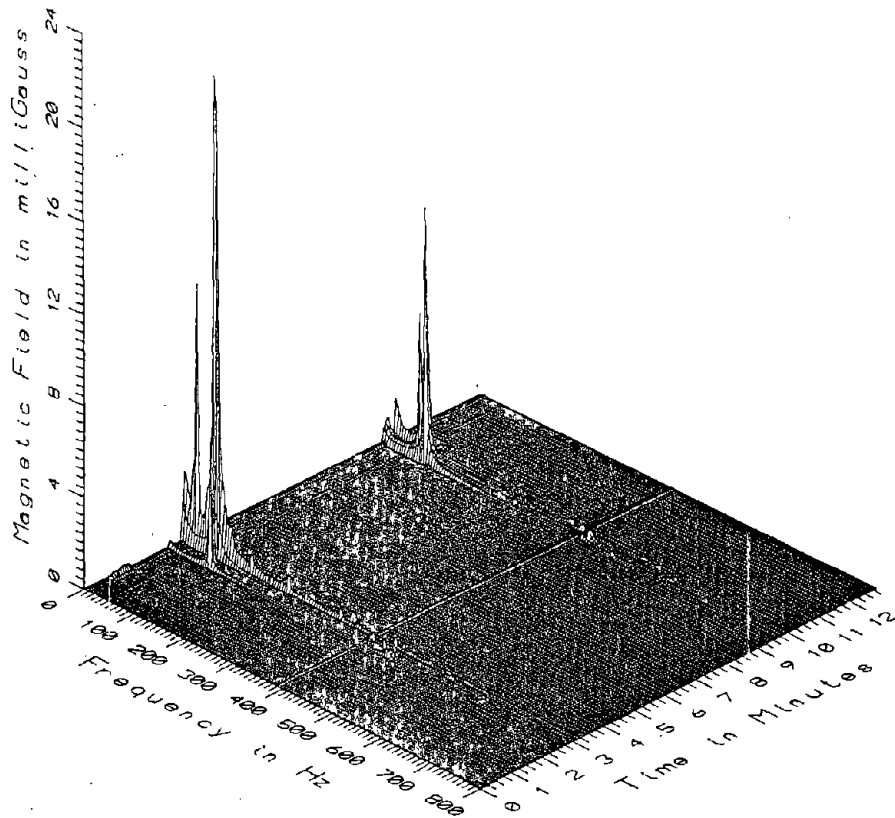

TR7019 - 4M NE OF LOW CONCRETE G/W IN SOUTH LOOP, 25M NW OF PROFILE

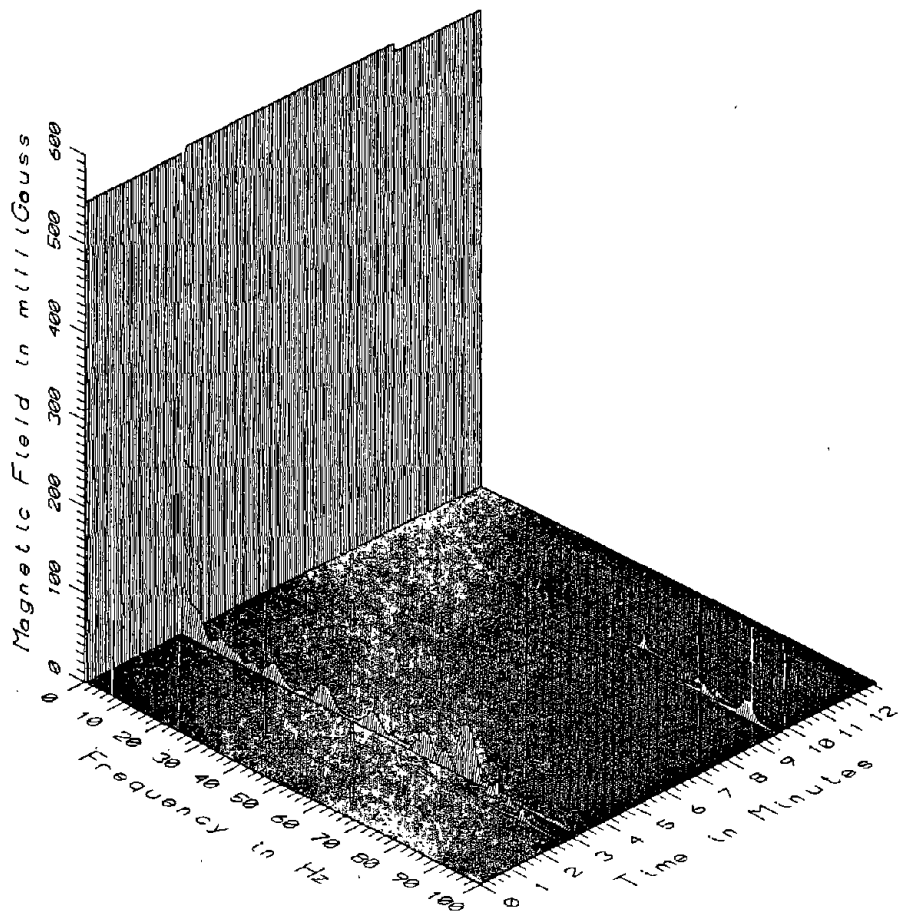

TR7019 - UNDER CENTER OF LOW CONCRETE G/W IN SOUTH LOOP

0-5

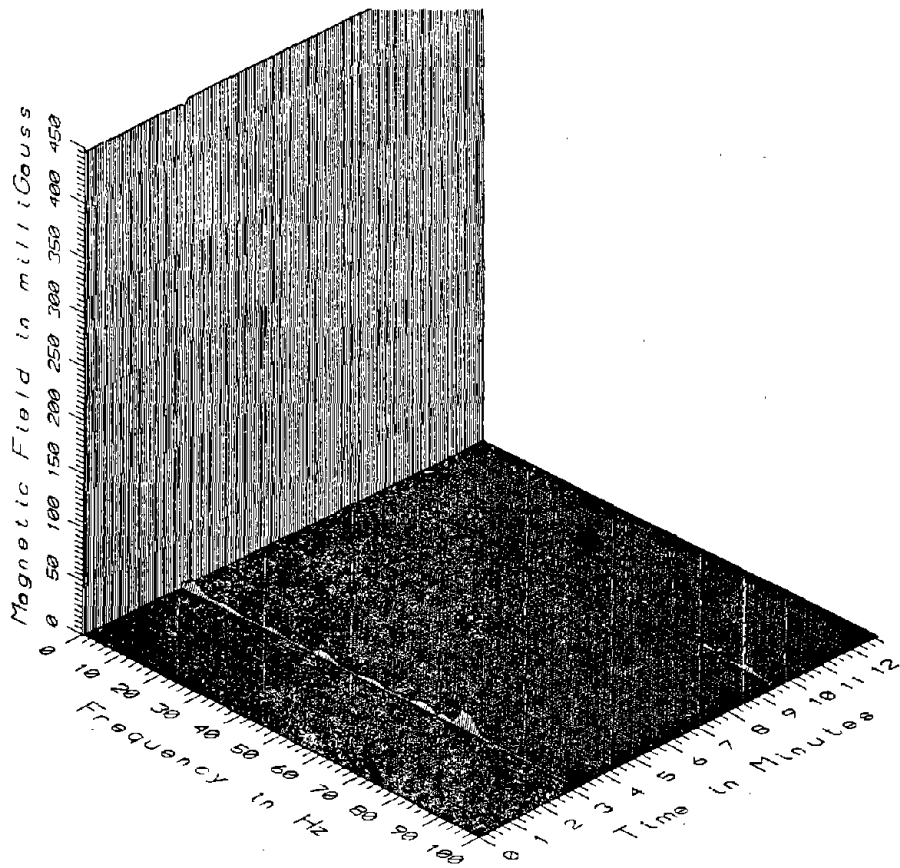

TR7019 - 4M NE OF LOW CONCRETE G/W IN SOUTH LOOP

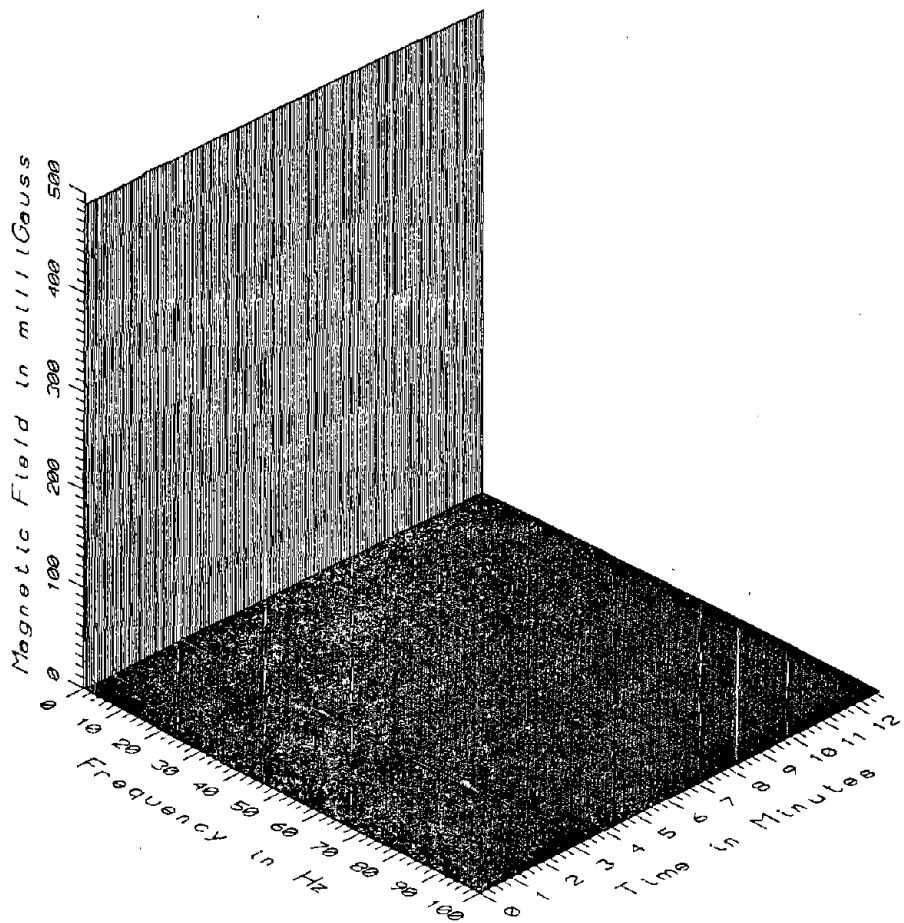

TR7019 - 10M NE OF LOW CONCRETE G/W IN SOUTH LOOP

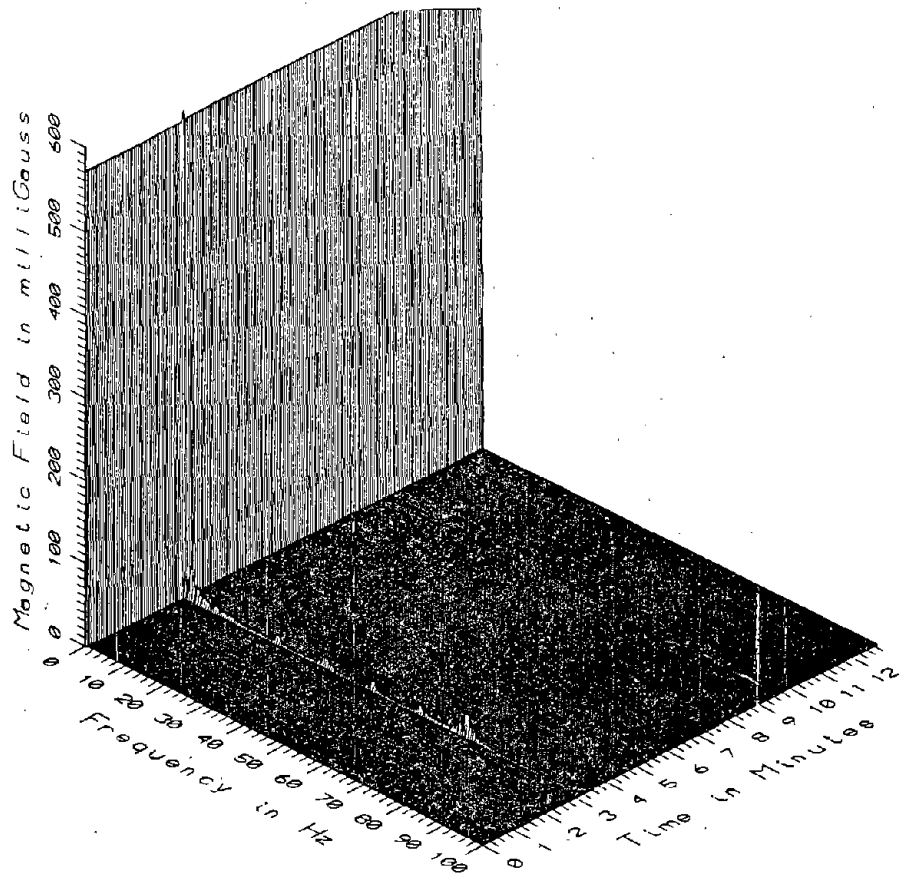

TR7019 - 4M NE OF LOW CONCRETE G/W IN SOUTH LOOP, 25M SE OF PROFILE

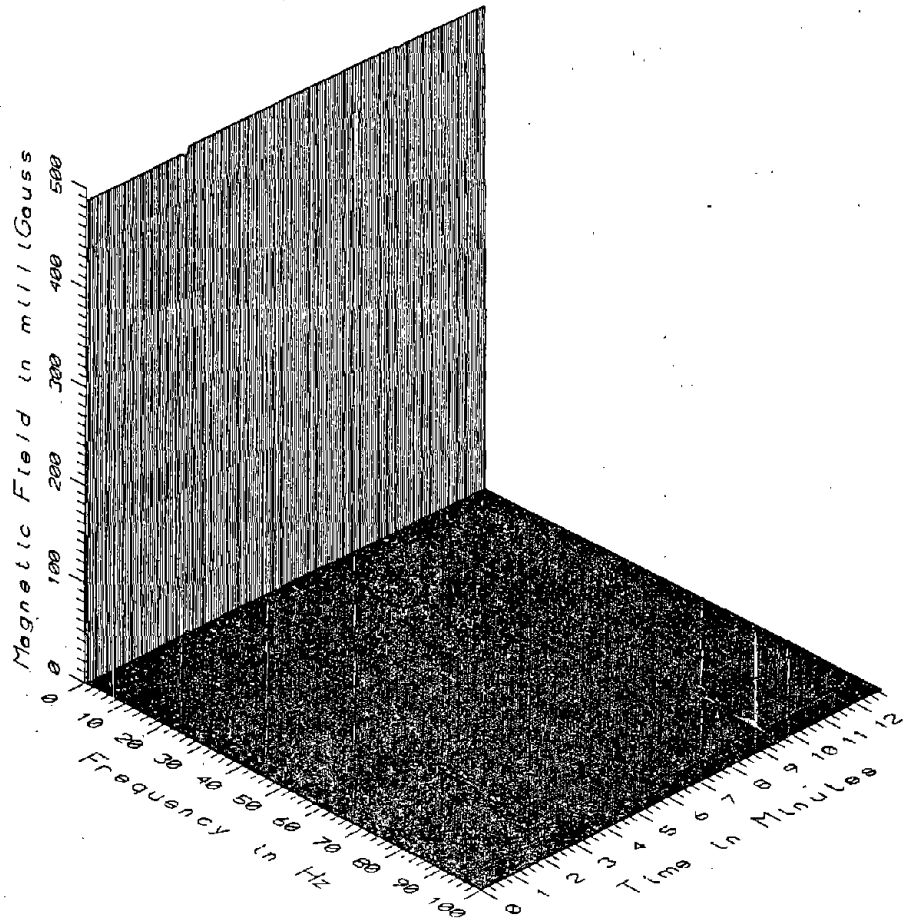

TR7019 - 4M NE OF LOW CONCRETE G/W IN SOUTH LOOP, 25M SE OF PROFILE

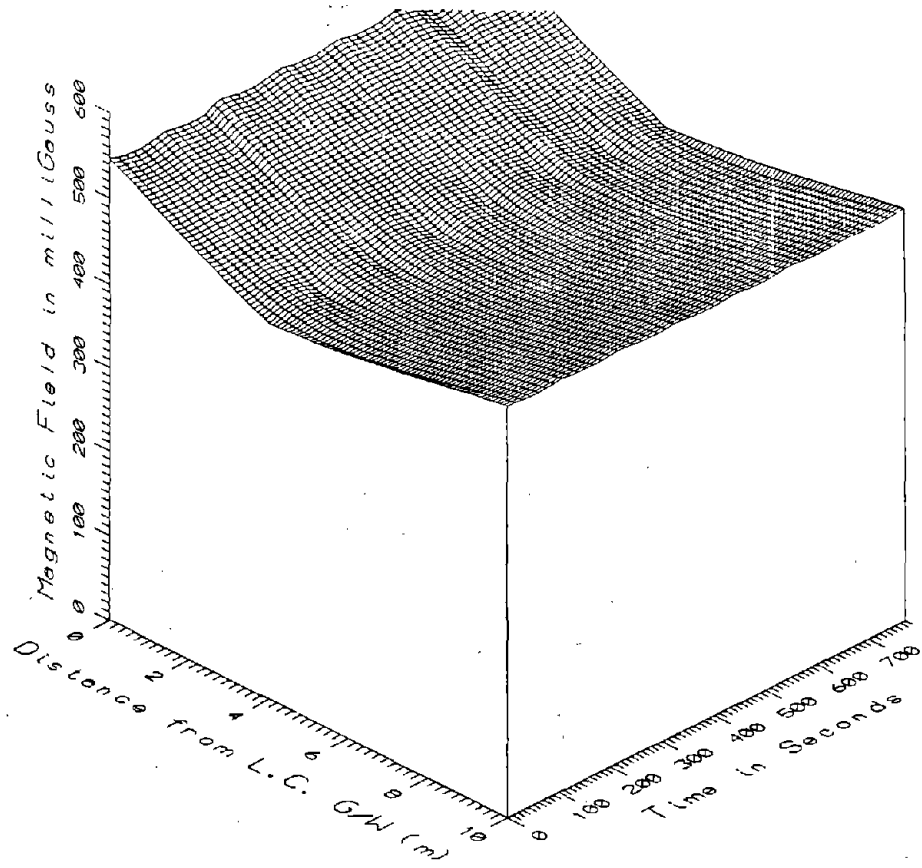

TR7019, LOW CONCRETE GUIDEWAY IN SOUTH LOOP - DC

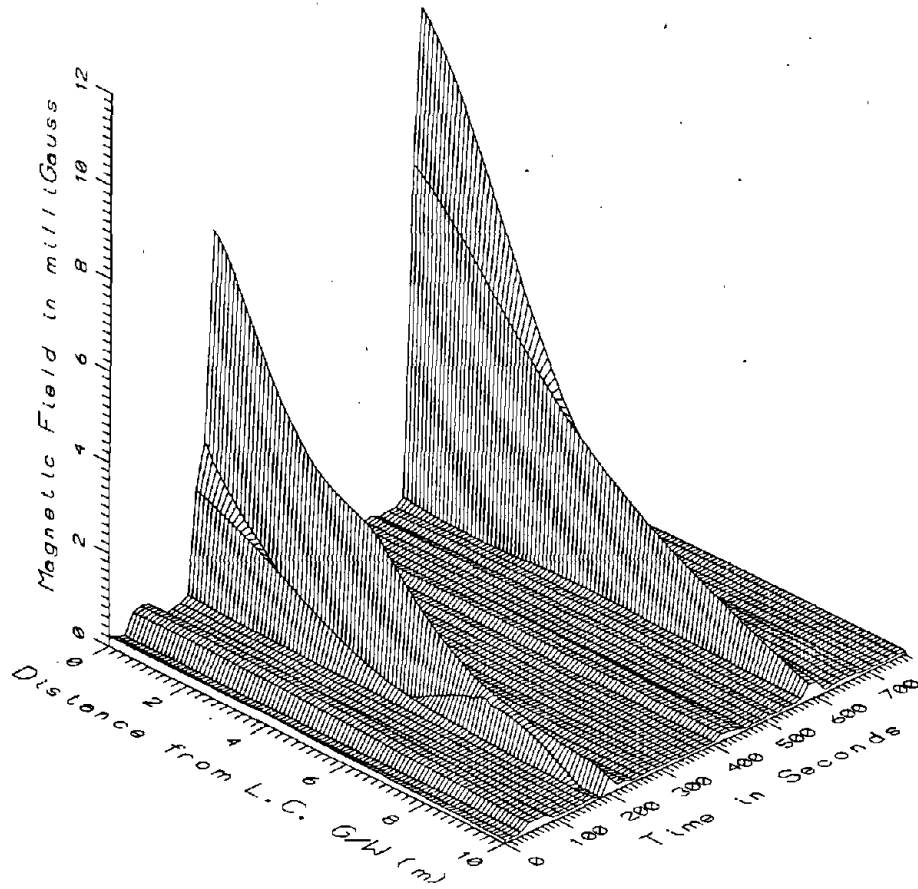

TR7019, LOW CONCRETE GUIDEWAY IN SOUTH LOOP - LOW FREQUENCY, 5-45Hz

0-8

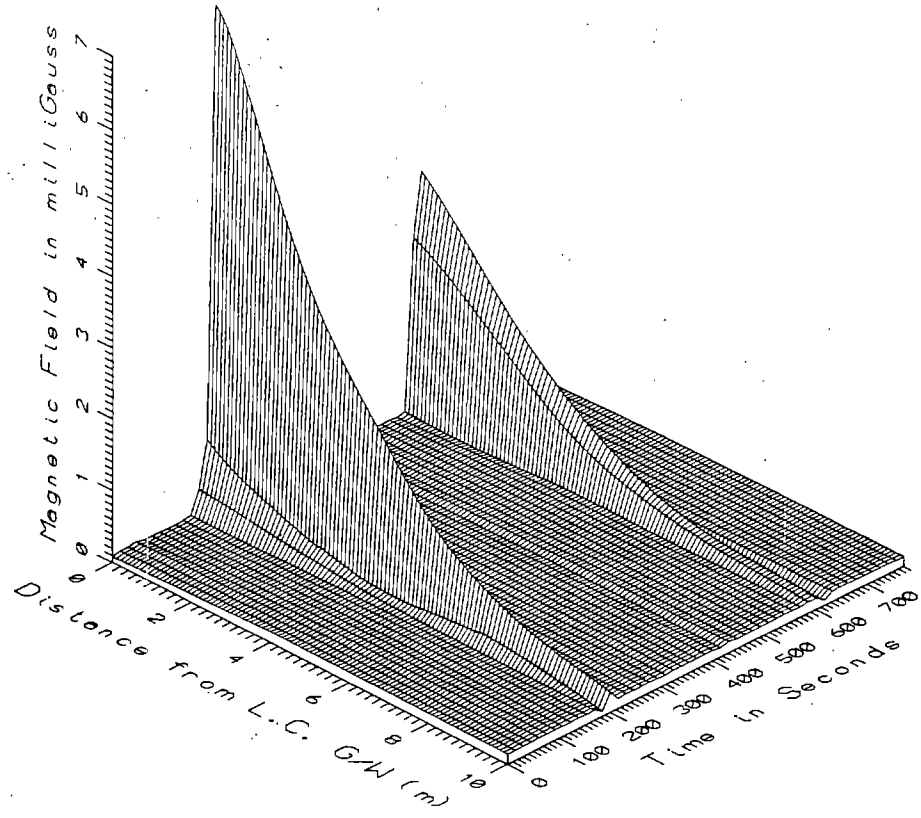

TR7019. LOW CONCRETE GUIDEWAY IN SOUTH LOOP - POWER FREQUENCY, 50-60Hz

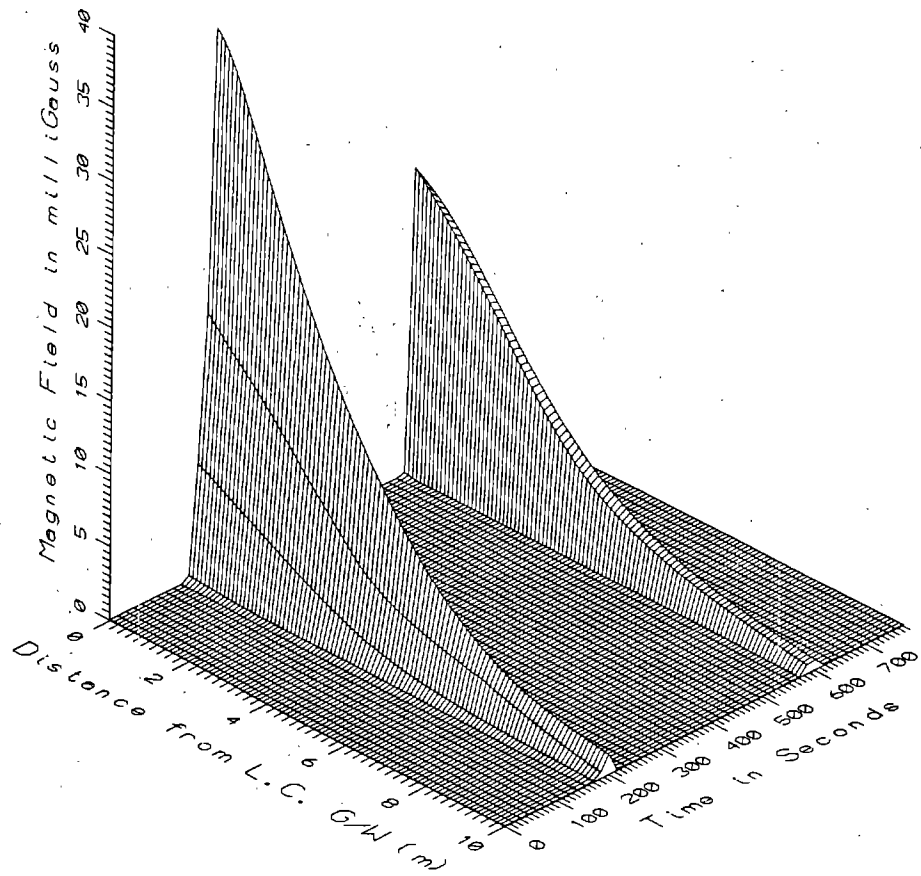

TR7019. LOW CONCRETE GUIDEWAY IN SOUTH LOOP - POWER HARMONICS, 65-300Hz

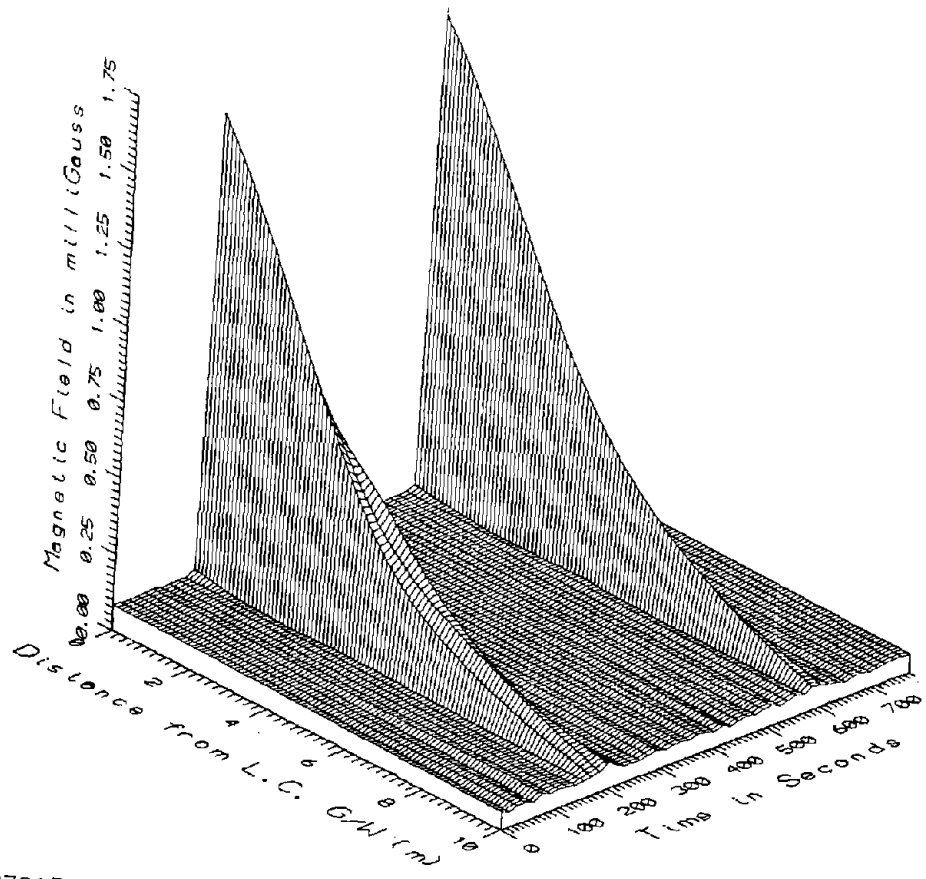

TR7019. LOW CONCRETE GUIDEWAY IN SOUTH LOOP - HIGH FREQUENCY, 305-2560Hz

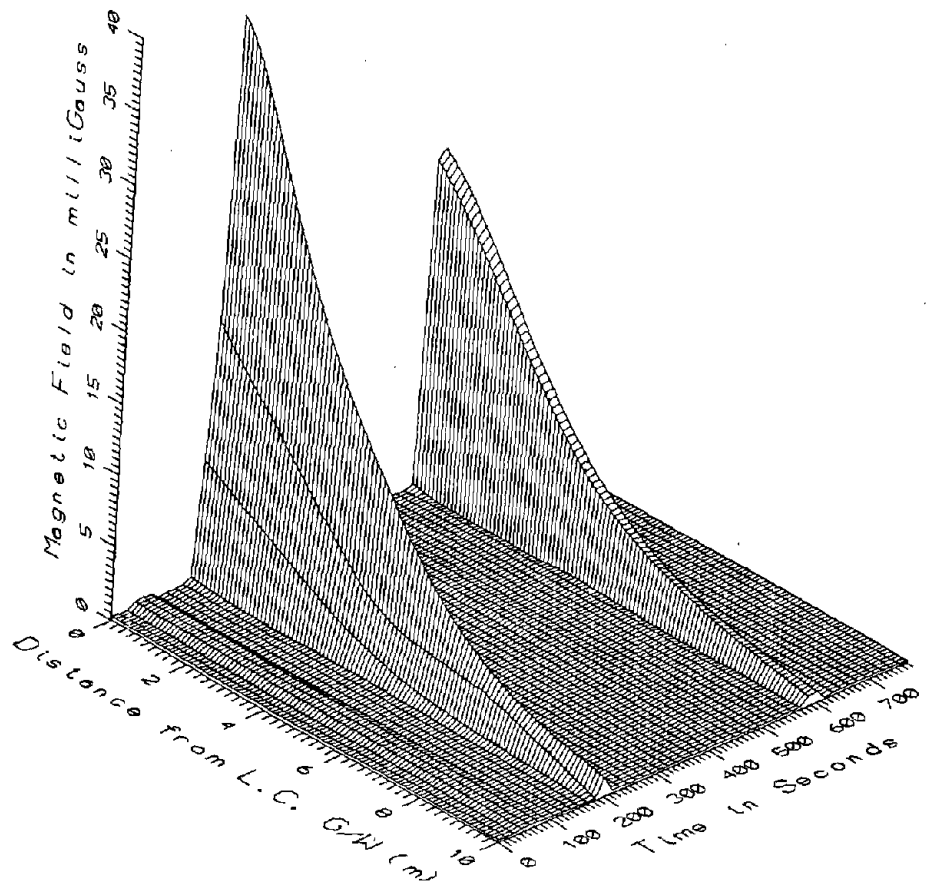

TR7019. LOW CONCRETE GUIDEWAY IN SOUTH LOOP - ALL FREQUENCIES, 5-2560Hz

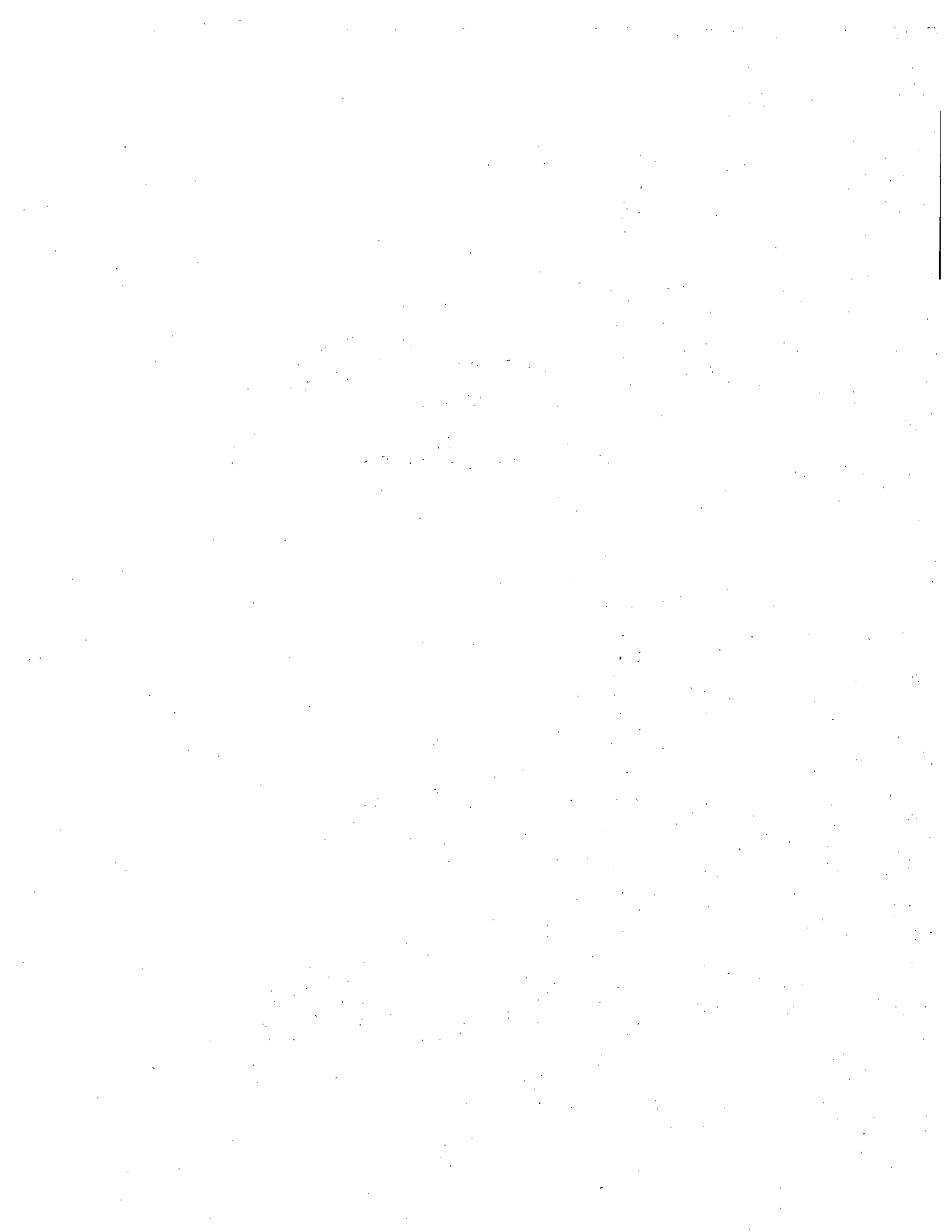

P-i

APPENDIX P

DATA SET 7020

**LATERAL PROFILE
AT THE PASSENGER STATION**

P-1

APPENDIX P

DATA SET 7020
LATERAL PROFILE AT THE PASSENGER STATION

Measurement Setup Code: 21
Vehicle Status: Running continuously
Measurement Date: August 9, 1990
Measurement Time: Start: 10:26:00
End: 10:46:00
Number of Samples: 229
Programmed Sample Interval: 4 sec
Actual Sample Interval: 5.3 sec

Frequency Spectrum Parameters

<u>Probe Type:</u>	<u>Coil (AC)</u>	<u>Fluxgate (DC)</u>
Maximum Frequency (Hz)	2560	256
Minimum Frequency (Hz)	5	0
Spectral Bandwidth (Hz)	5	0.5

Missing or Suspect Data: None

STATION PLATFORM MEASUREMENTS

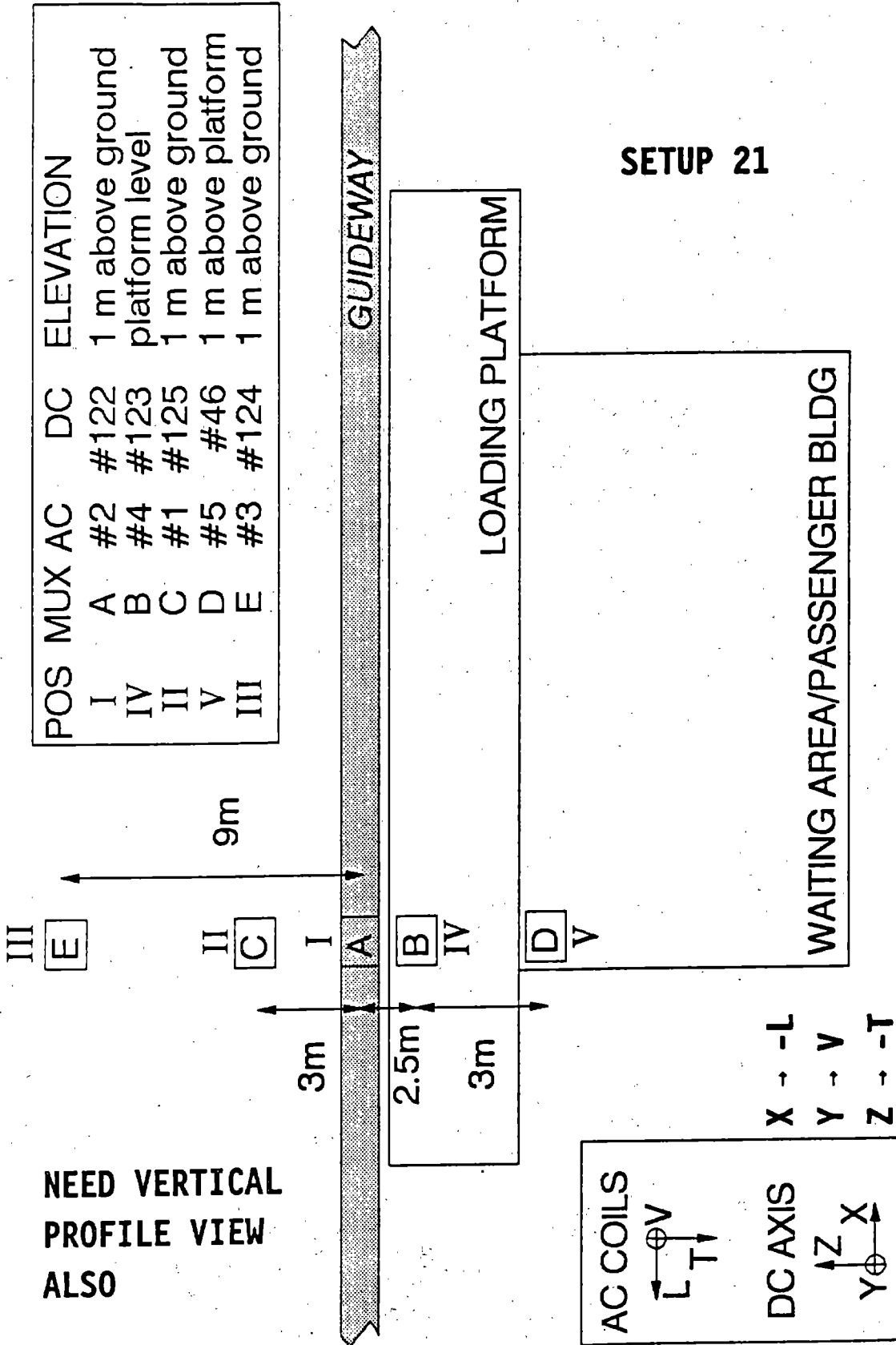

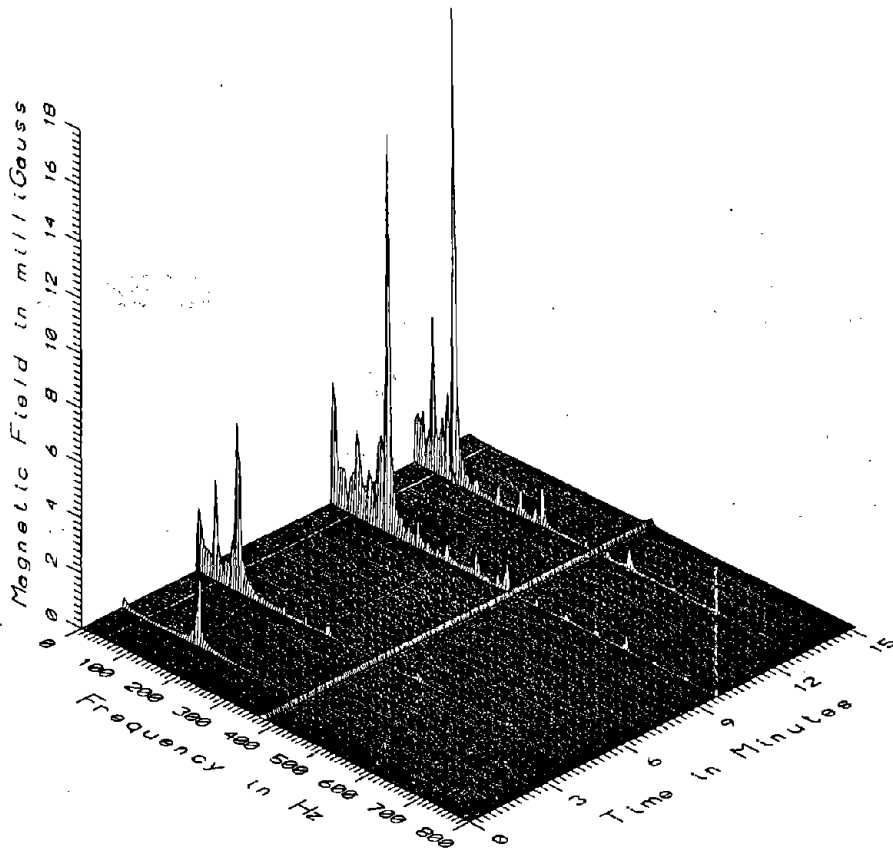

TR7020 - STATION PLATFORM - 9M WEST OF GUIDEWAY, 1M ABOVE GROUND

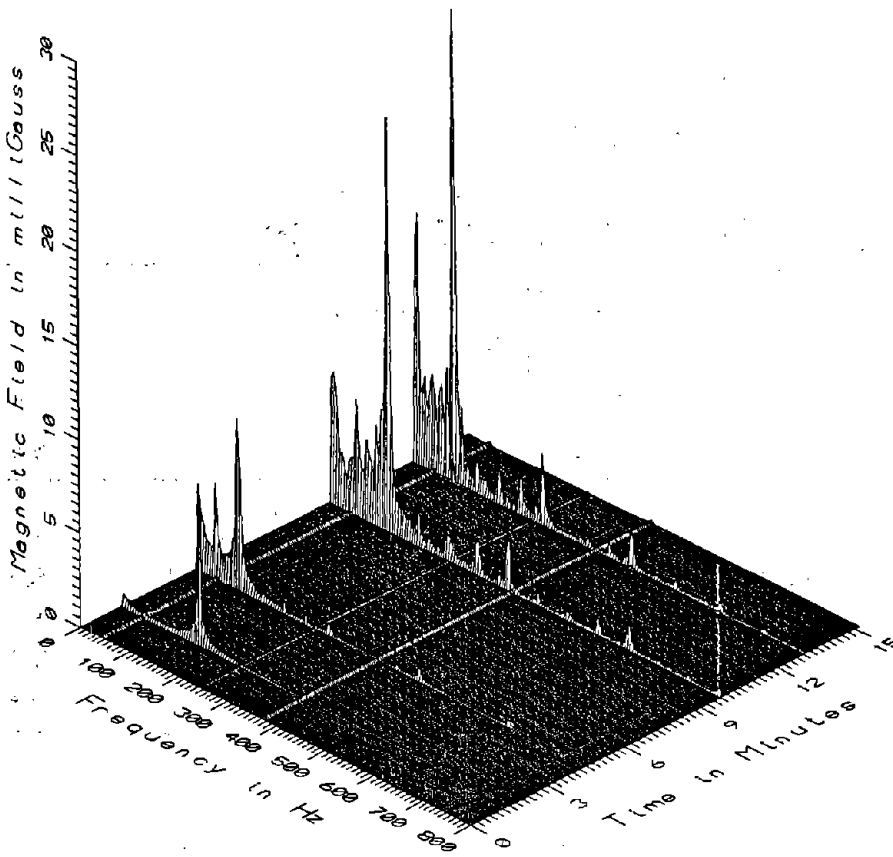

TR7020 - STATION PLATFORM - 3M WEST OF GUIDEWAY, 1M ABOVE GROUND

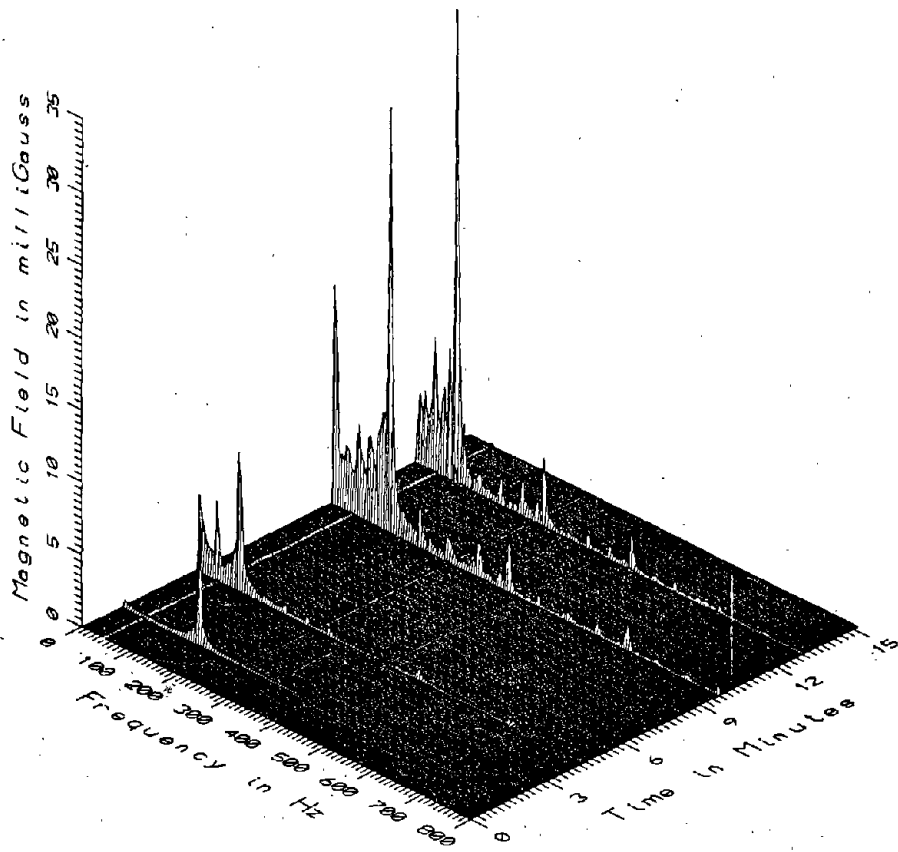

TR7020 - STATION PLATFORM - CENTER OF GUIDEWAY, 1M ABOVE GROUND

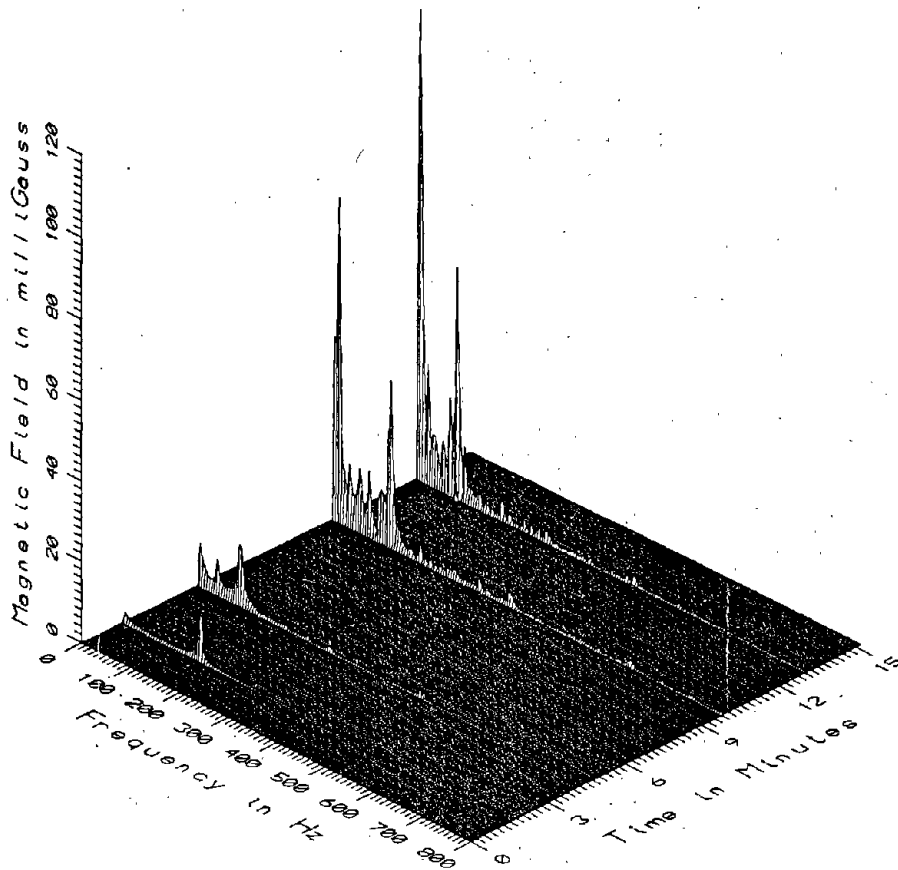

TR7020 - STATION PLATFORM - 2.5M EAST OF GUIDEWAY, PLATFORM LEVEL

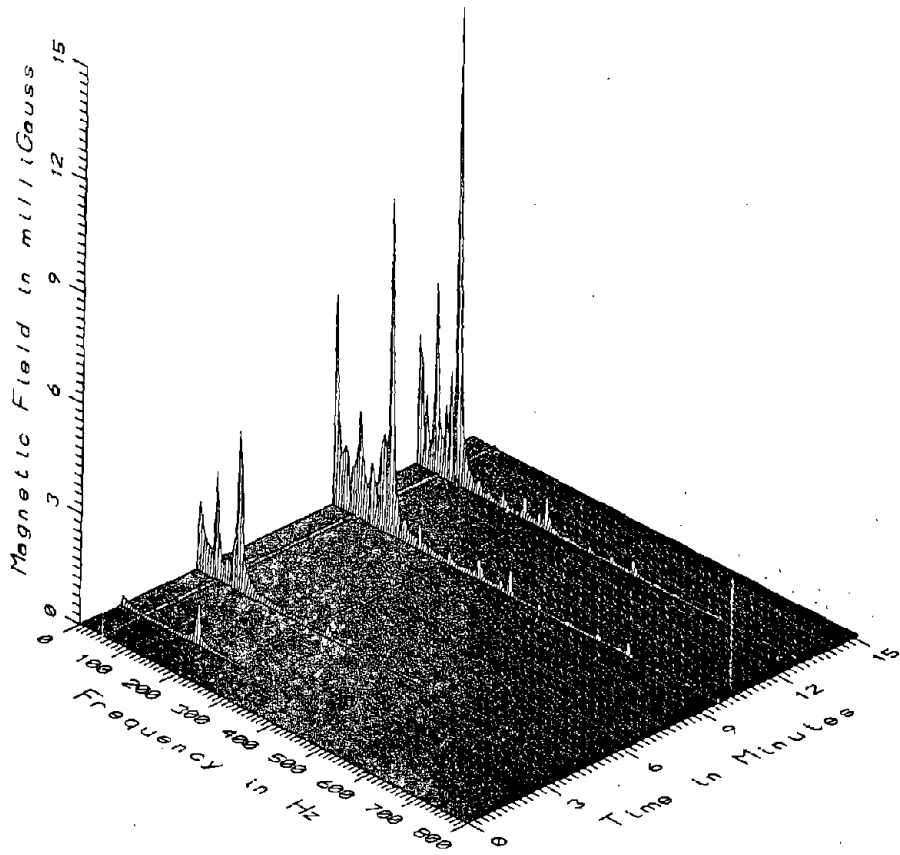

TR7020 - STATION PLATFORM - 5.5M EAST OF GUIDEWAY, 1M ABOVE PLATFORM

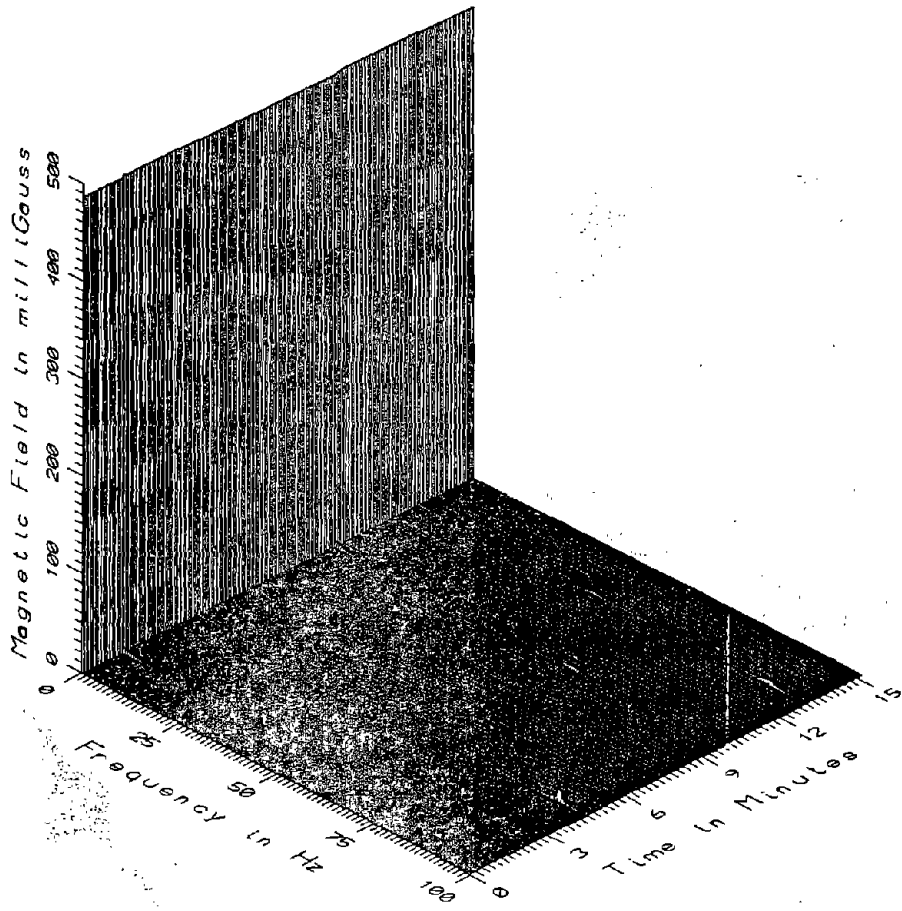

TR7020 - STATION PLATFORM - 9M WEST OF GUIDEWAY, 1M ABOVE GROUND

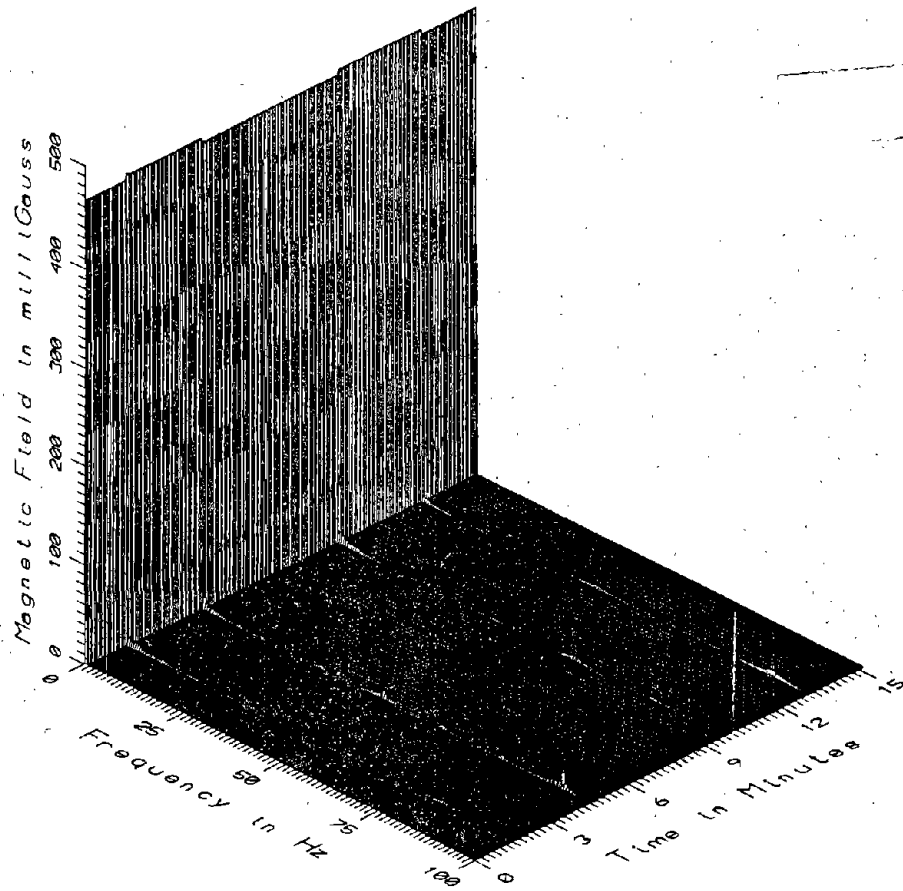

TR7020 - STATION PLATFORM - 3M WEST OF GUIDEWAY, 1M ABOVE GROUND

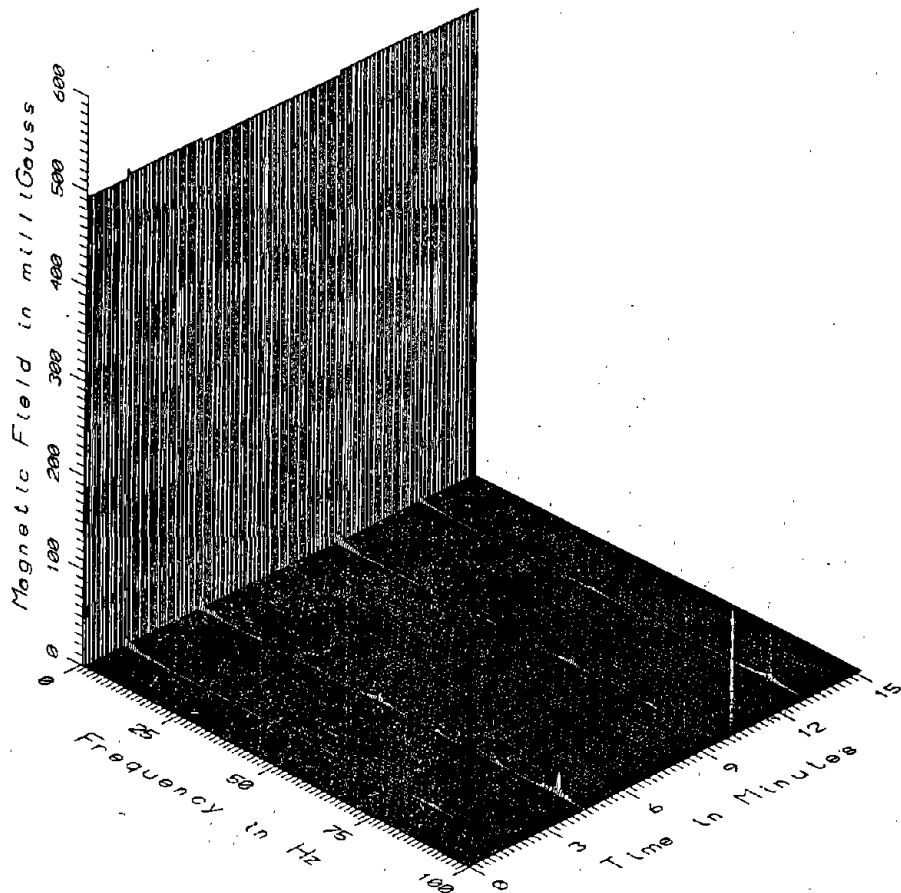

TR7020 - STATION PLATFORM - CENTER OF GUIDEWAY, 1M ABOVE GROUND

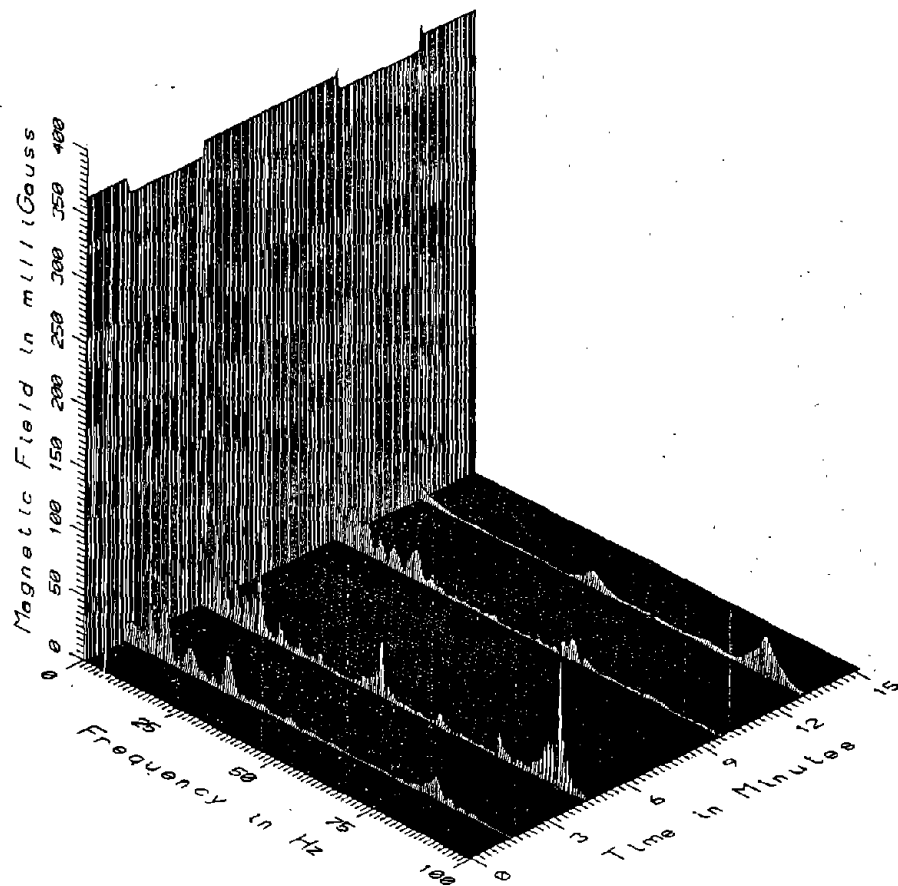

TR7020 - STATION PLATFORM - 2.5M EAST OF GUIDEWAY, PLATFORM LEVEL

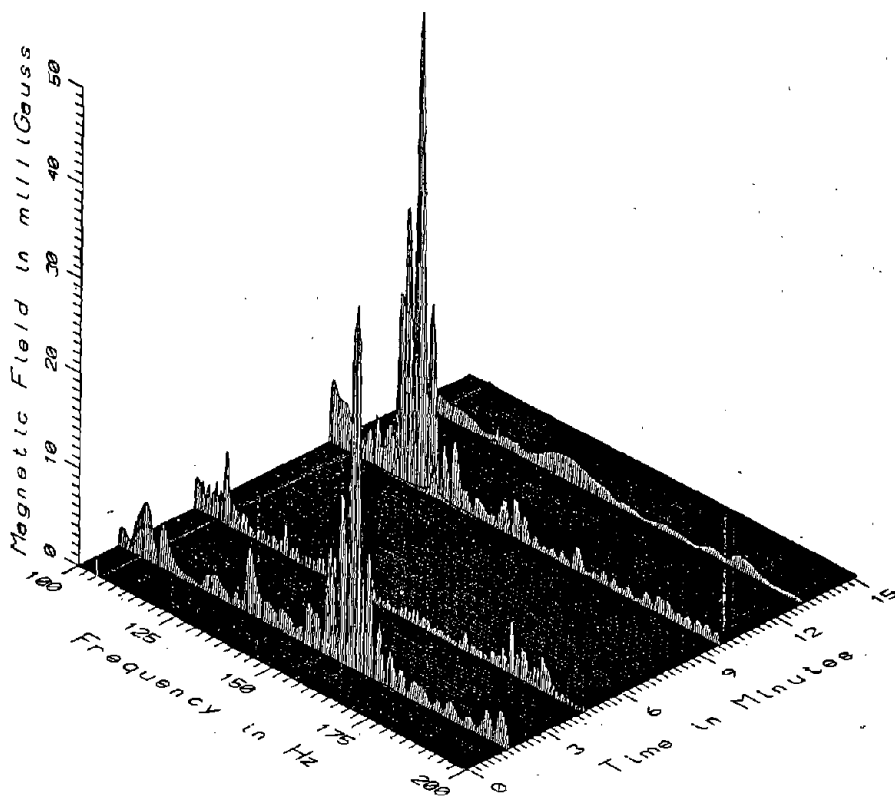

TR7020 - STATION PLATFORM - 2.5M EAST OF GUIDEWAY, PLATFORM LEVEL

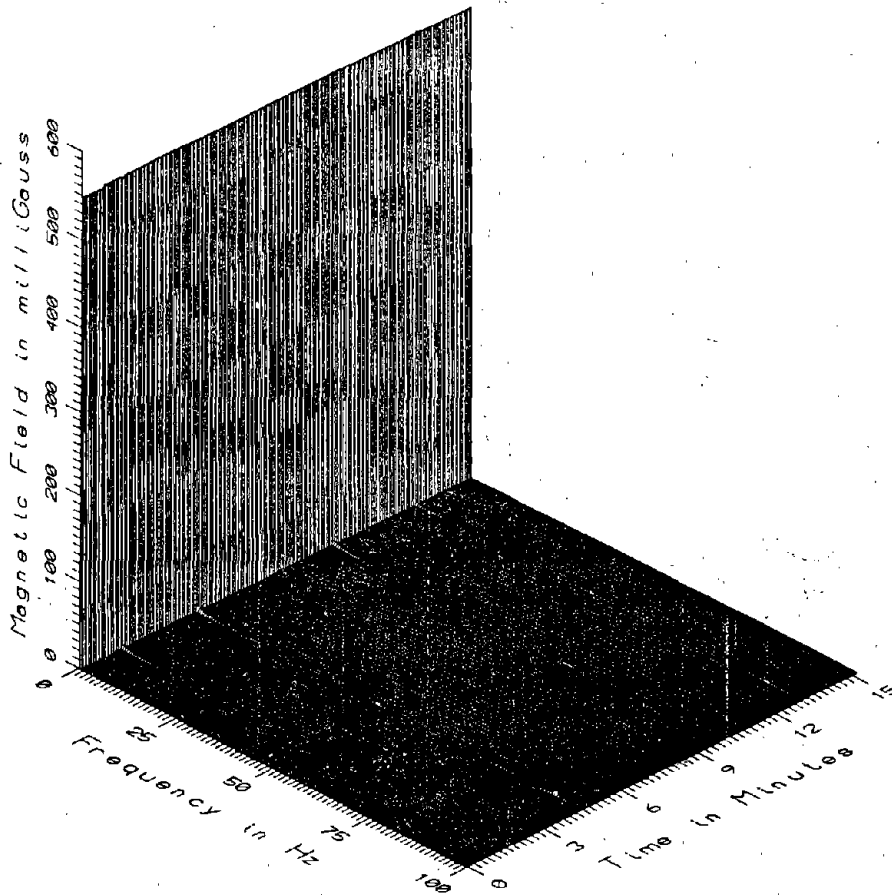

TR7020 - STATION PLATFORM - 5.5M EAST OF GUIDEWAY, 1M ABOVE PLATFORM

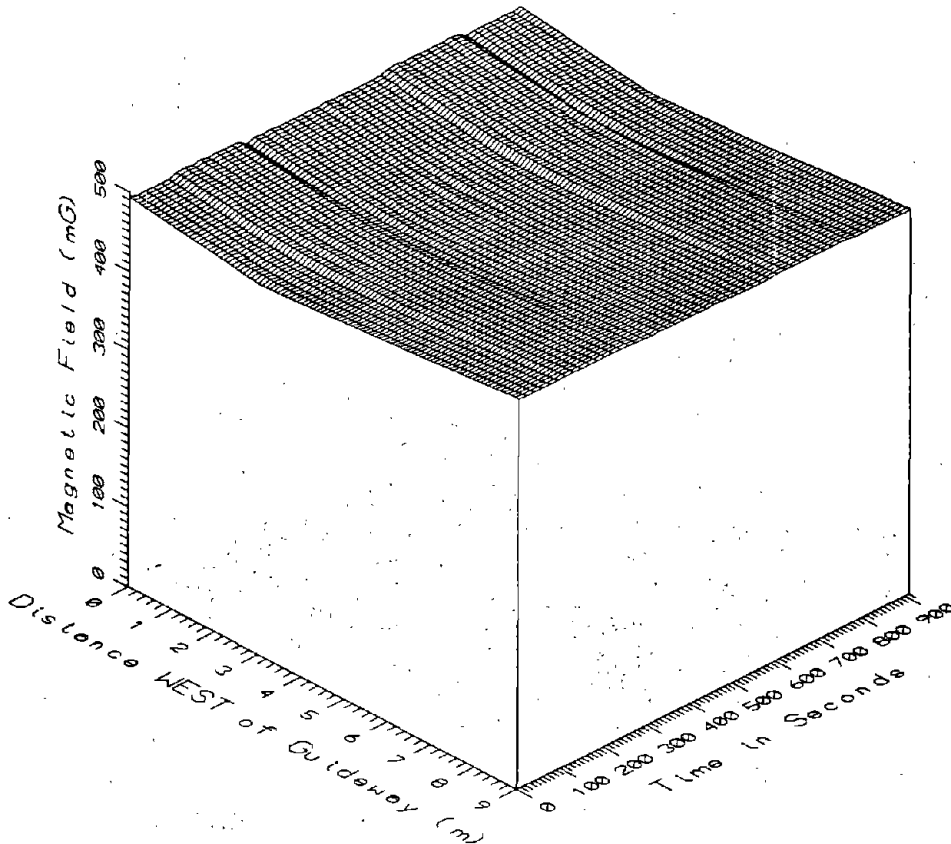

TR7020, GUIDEWAY AT LOADING PLATFORM - DC

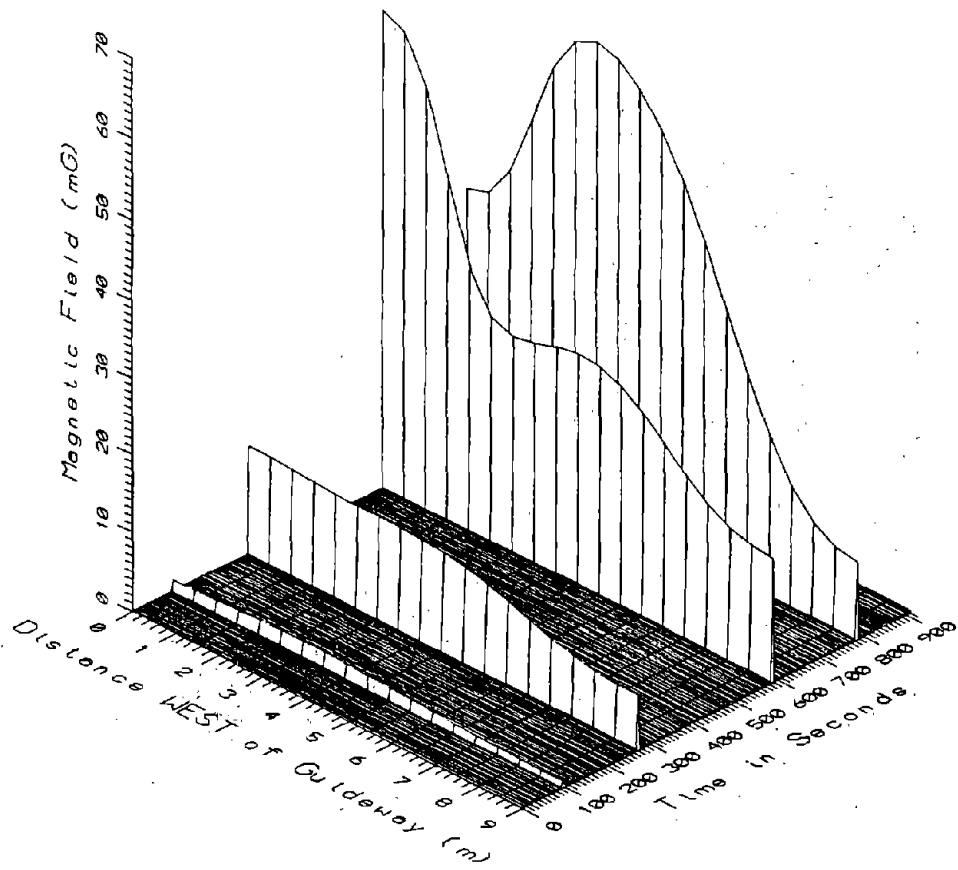

TR7020, GUIDEWAY AT LOADING PLATFORM - LOW FREQUENCY, 5-45Hz

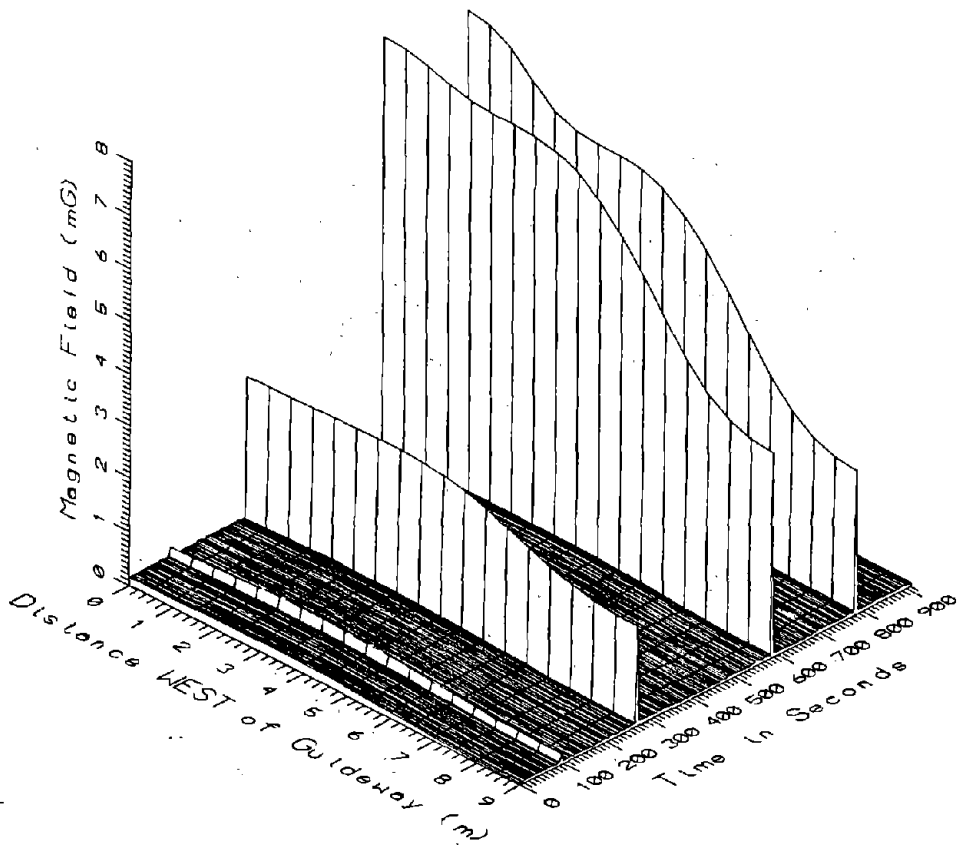

TR7020, GUIDEWAY AT LOADING PLATFORM - POWER FREQUENCY, 50-60Hz

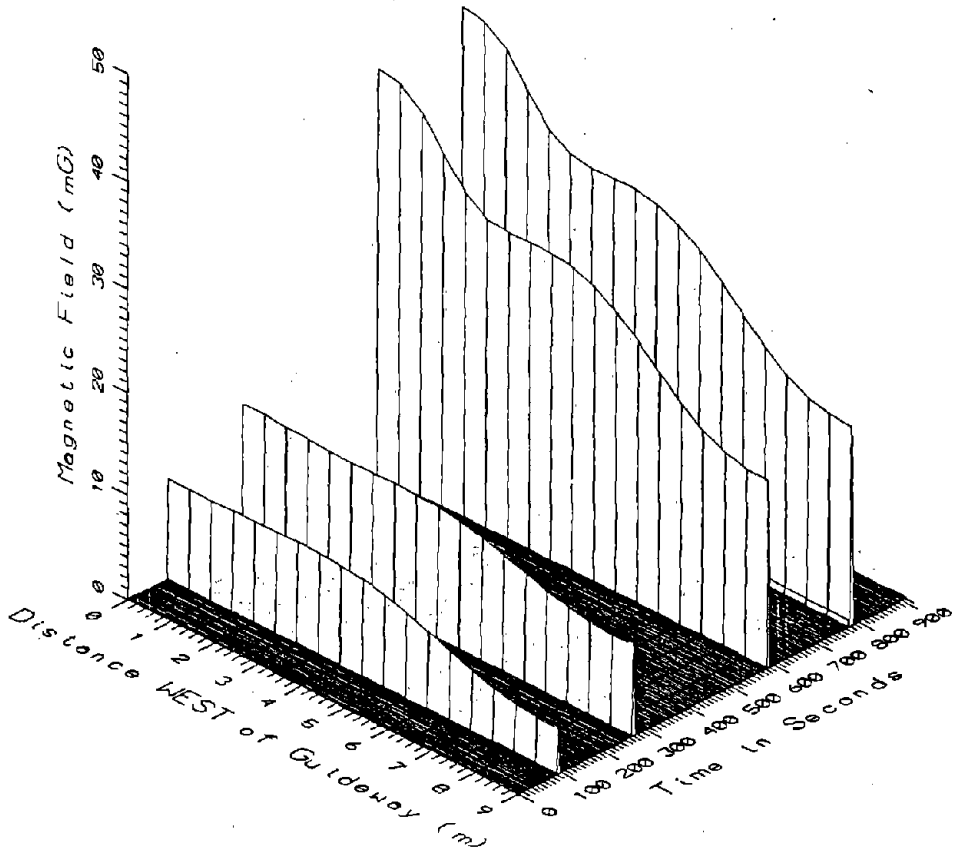

TR7020, GUIDEWAY AT LOADING PLATFORM - POWER HARMONICS, 65-300Hz

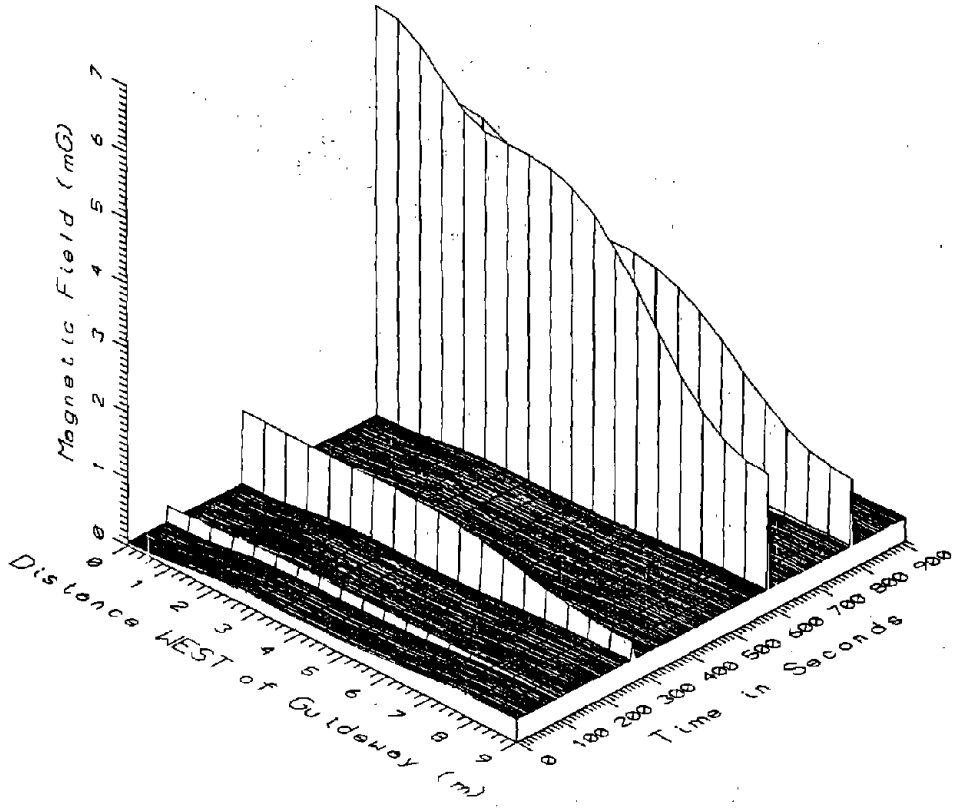

TR7020, GUIDEWAY AT LOADING PLATFORM - HIGH FREQUENCY, 305-2560Hz

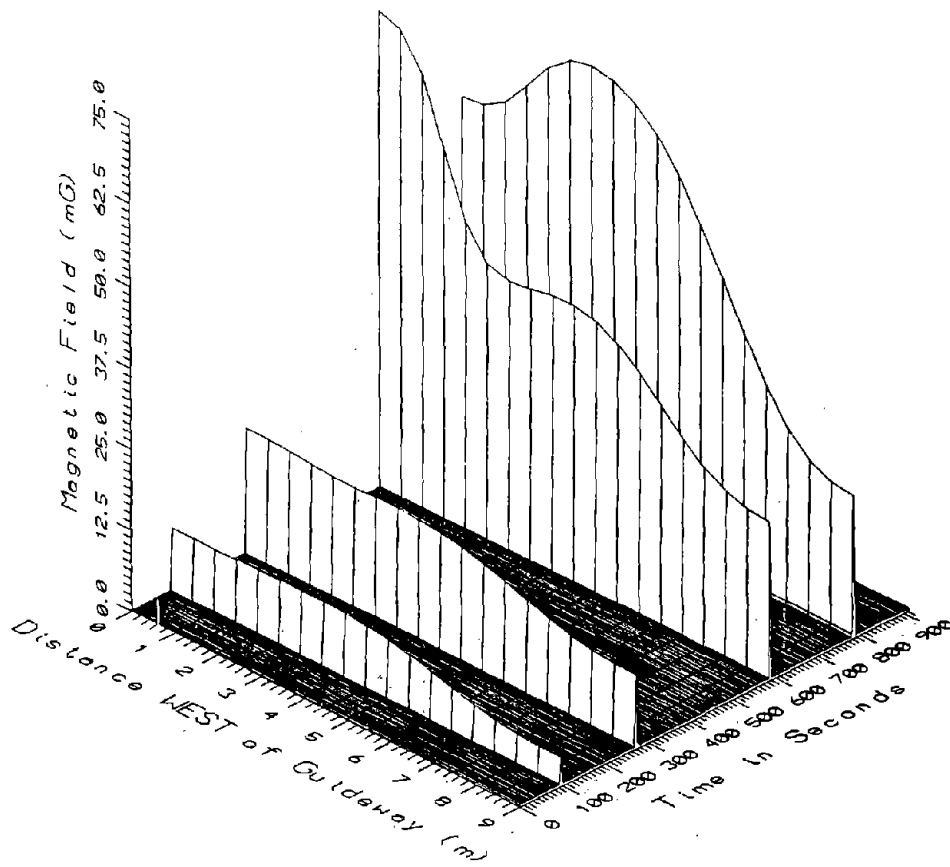

TR7020, GUIDEWAY AT LOADING PLATFORM - ALL FREQUENCIES, 5-2560Hz

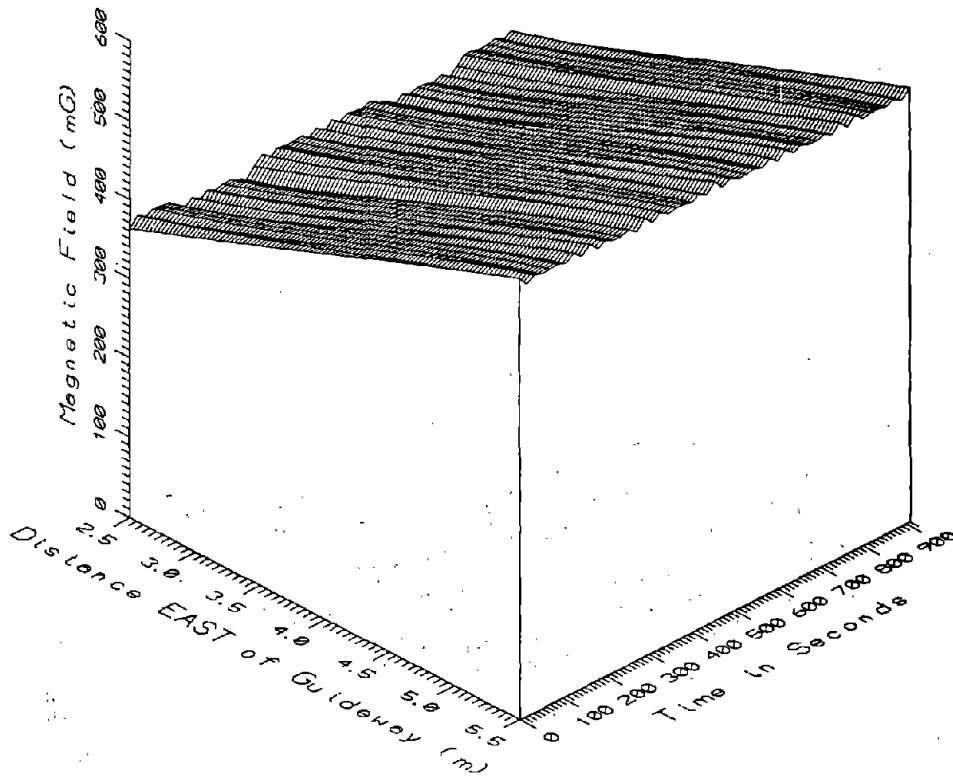

TR7020, GUIDEWAY AT LOADING PLATFORM - DC

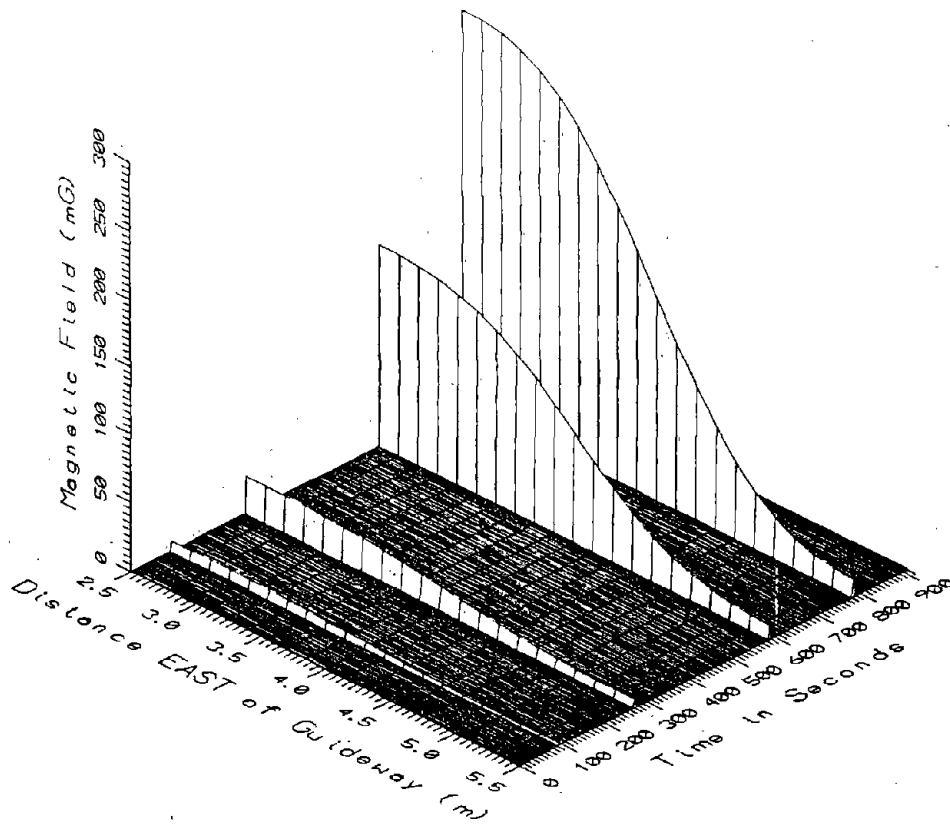

TR7020, GUIDEWAY AT LOADING PLATFORM - LOW FREQUENCY, 5-45Hz

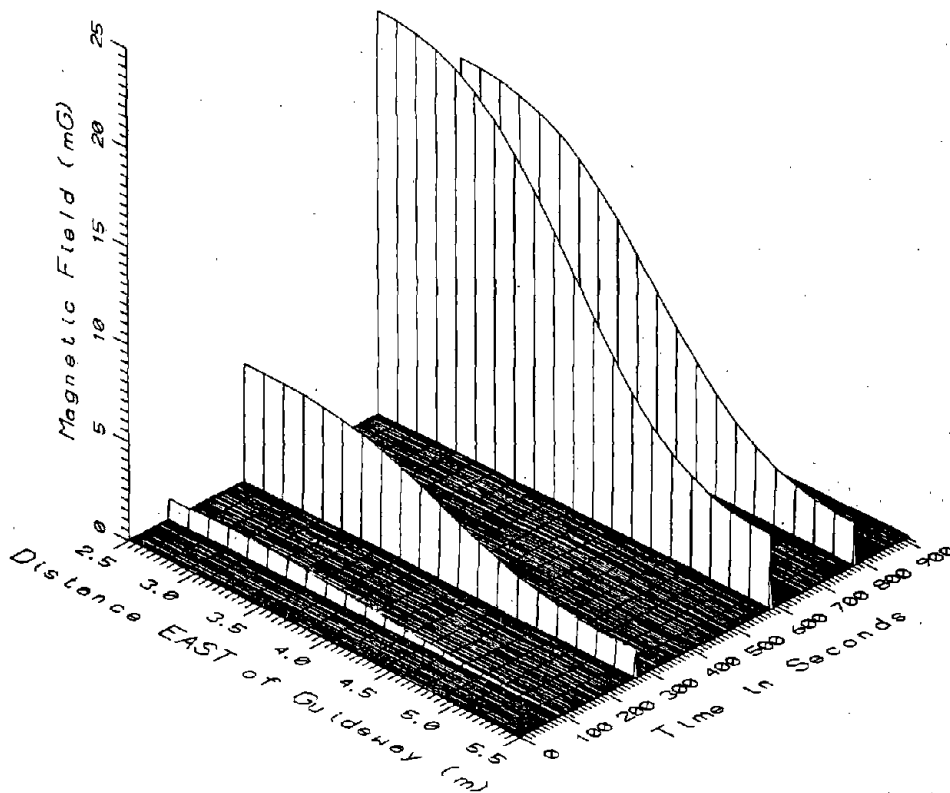

TR7020, GUIDEWAY AT LOADING PLATFORM - POWER FREQUENCY, 50-60Hz

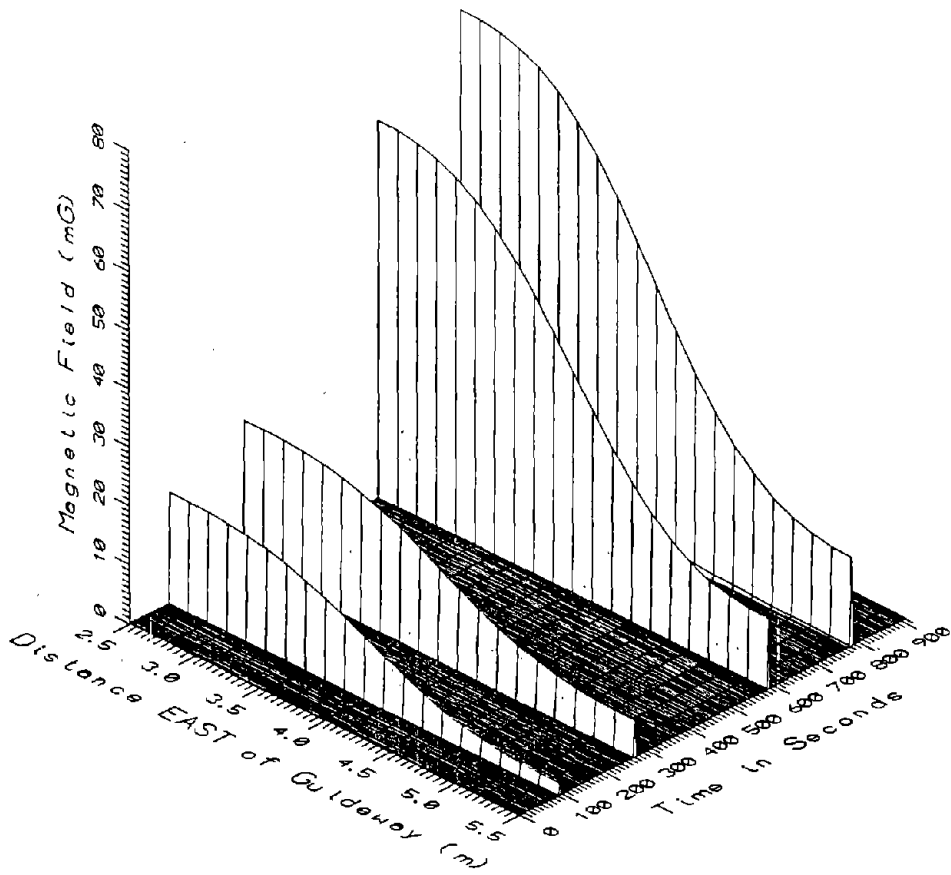

TR7020, GUIDEWAY AT LOADING PLATFORM - POWER HARMONICS, 65-300Hz

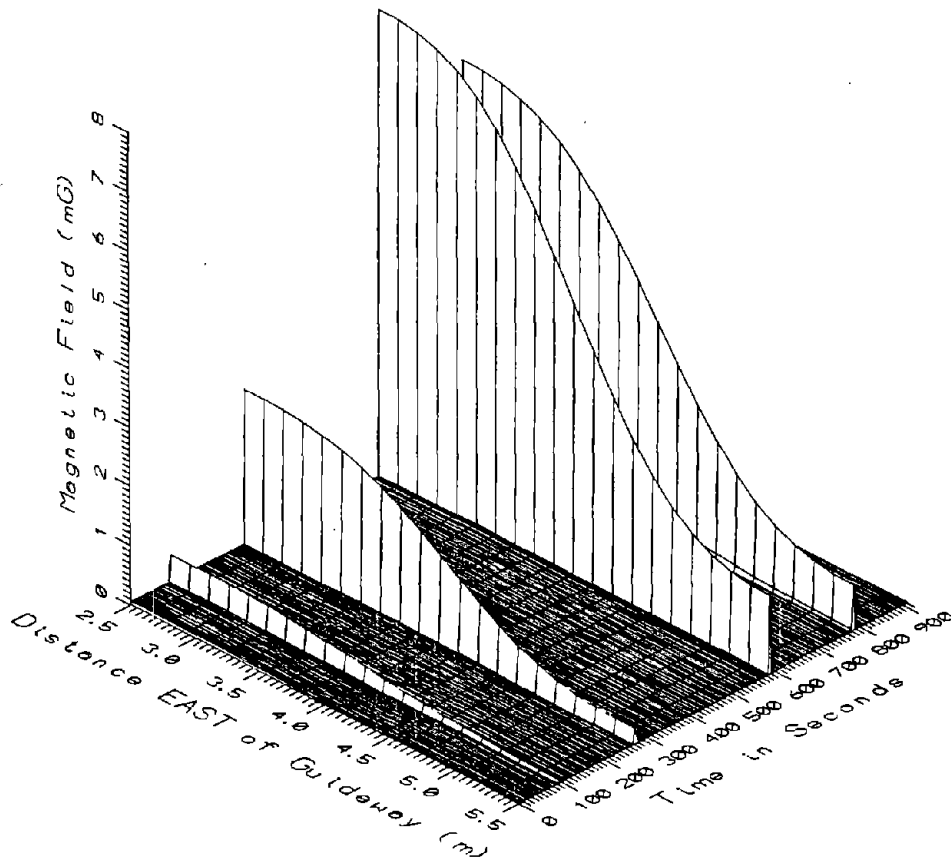

TR7020, GUIDEWAY AT LOADING PLATFORM - HIGH FREQUENCY, 305-2560Hz

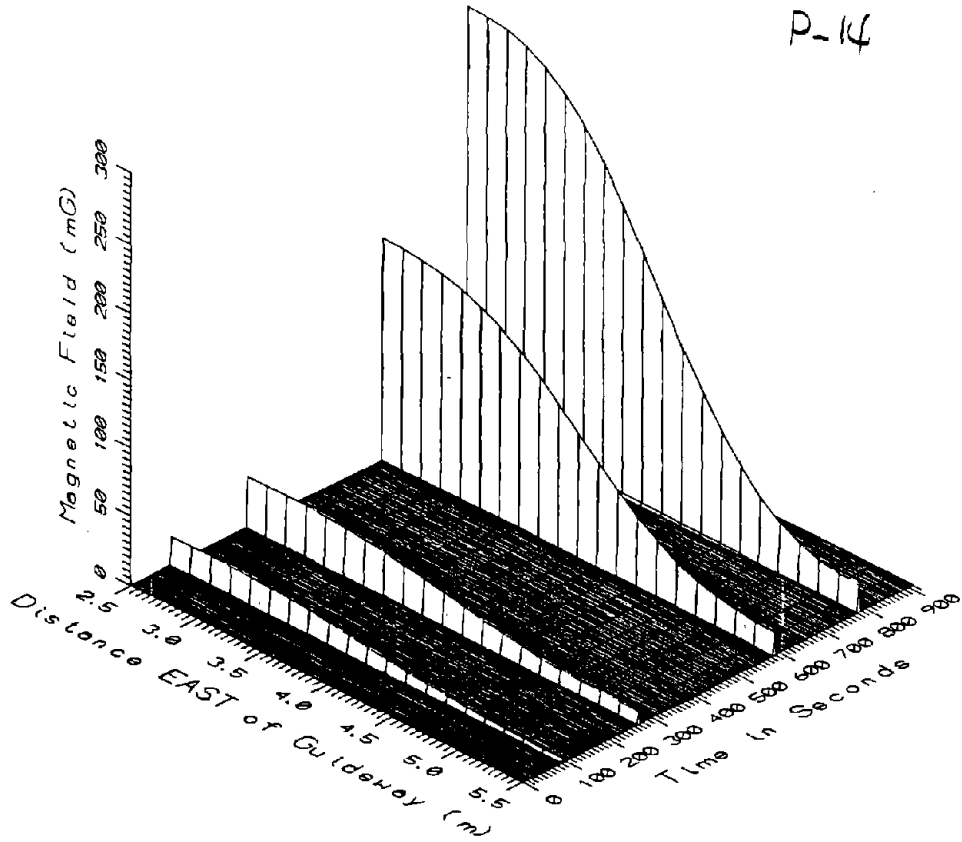

TR7020, GUIDEWAY AT LOADING PLATFORM - ALL FREQUENCIES, 5-2560Hz



Q-i

APPENDIX Q

DATA SET TR7021

**LATERAL PROFILE
AT THE PASSENGER STATION**

Q-1

APPENDIX Q

DATA SET TR7021
LATERAL PROFILE AT THE PASSENGER STATION

Measurement Setup Code: 21
Vehicle Status: Running continuously
Measurement Date: August 9, 1990
Measurement Time: Start: 10:51:00
End: 11:10:00
Number of Samples: 229
Programmed Sample Interval: 5 sec
Actual Sample Interval: 5 sec

Frequency Spectrum Parameters

<u>Probe Type:</u>	<u>Coil (AC)</u>	<u>Fluxgate (DC)</u>
Maximum Frequency (Hz)	2560	256
Minimum Frequency (Hz)	5	0
Spectral Bandwidth (Hz)	5	0.5

Missing or Suspect Data: None

STATION PLATFORM MEASUREMENTS

NEED VERTICAL
PROFILE VIEW
ALSO

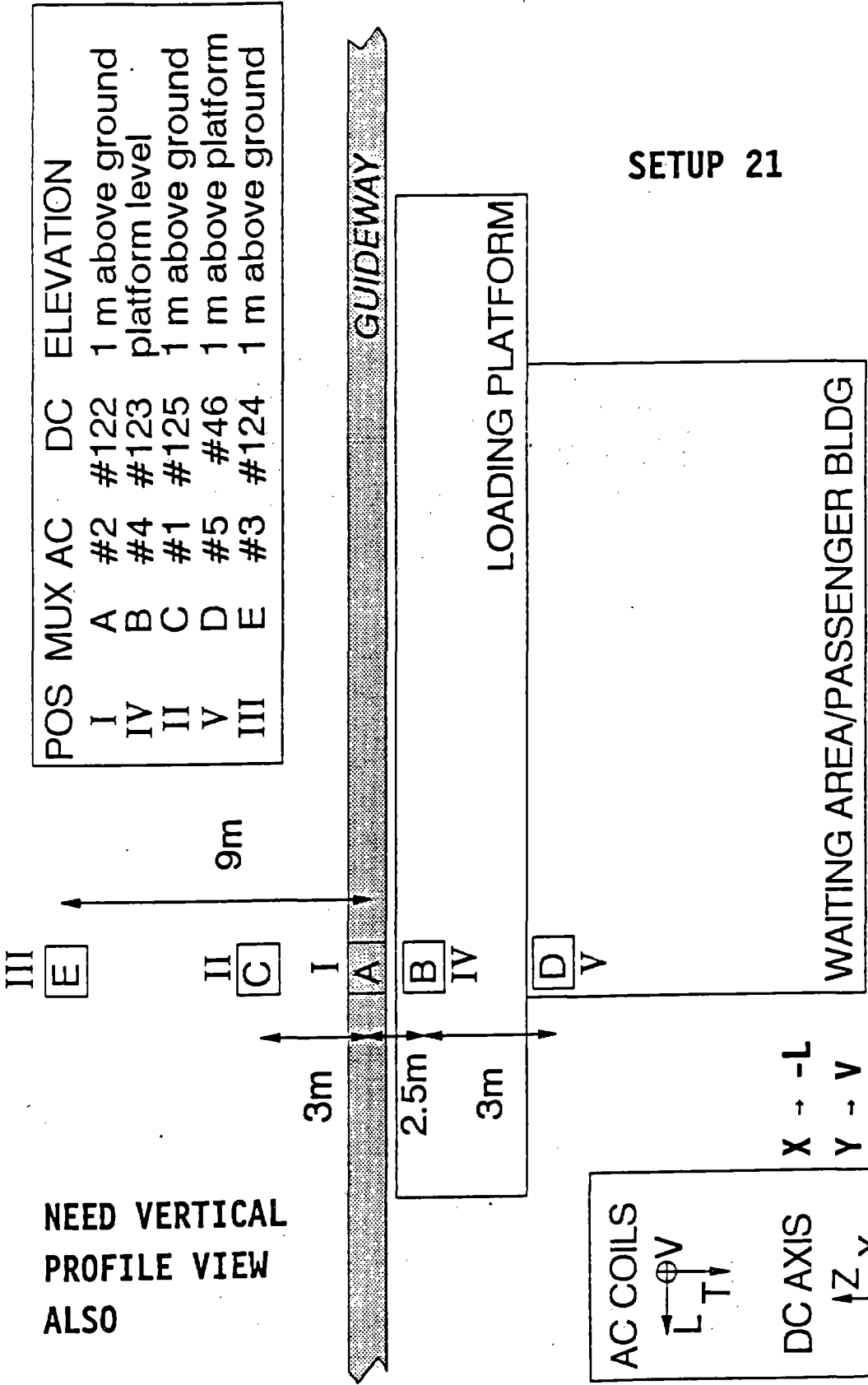

SETUP 21

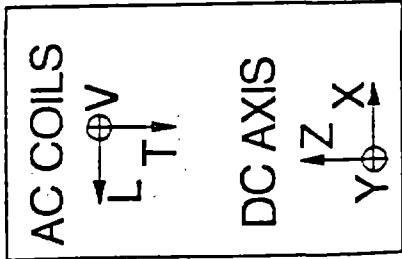

X → -L
 Y → V
 Z → -T

Q2

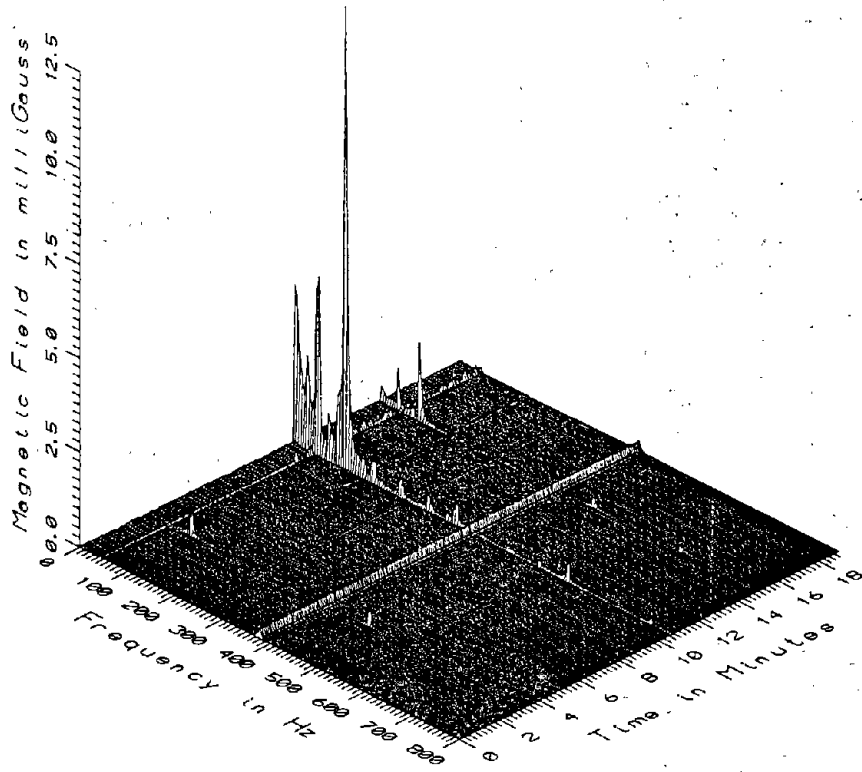

TR7021 - STATION PLATFORM - 9M WEST OF GUIDEWAY, 1M ABOVE GROUND

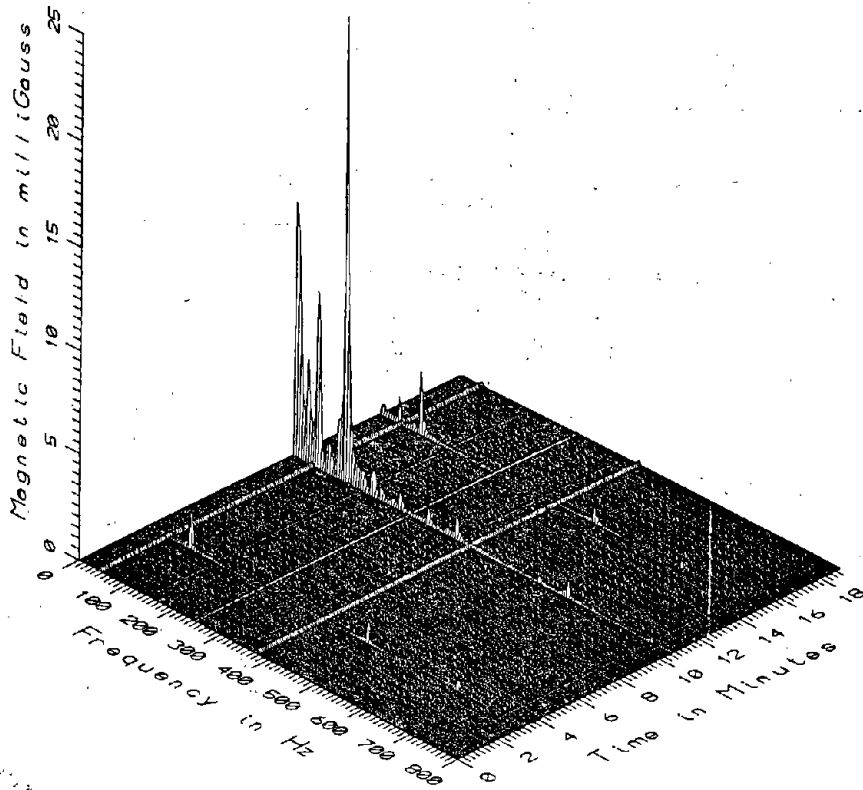

TR7021 - STATION PLATFORM - 3M WEST OF GUIDEWAY, 1M ABOVE GROUND

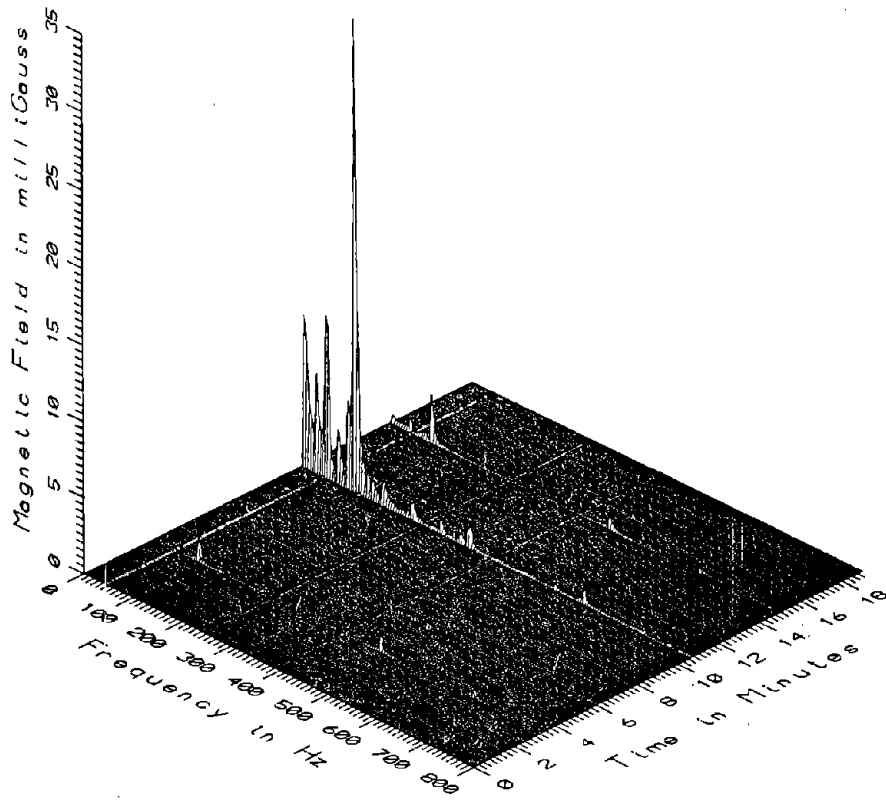

TR7021 - STATION PLATFORM - CENTER OF GUIDEWAY, 1M ABOVE GROUND

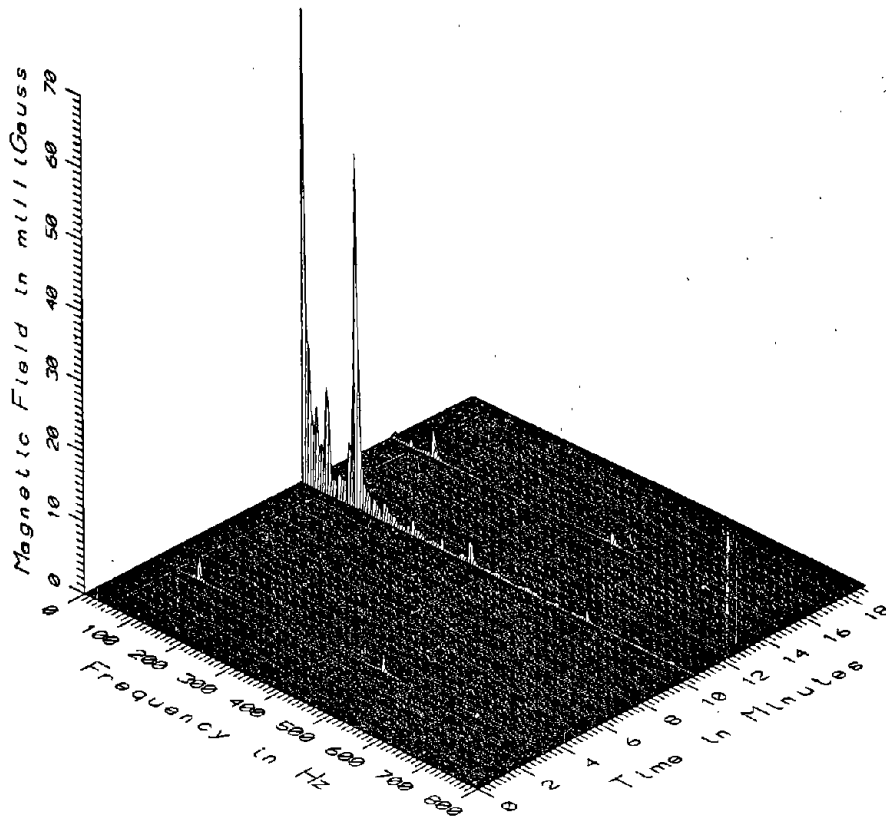

TR7021 - STATION PLATFORM - 2.5M EAST OF GUIDEWAY, PLATFORM LEVEL

G-4

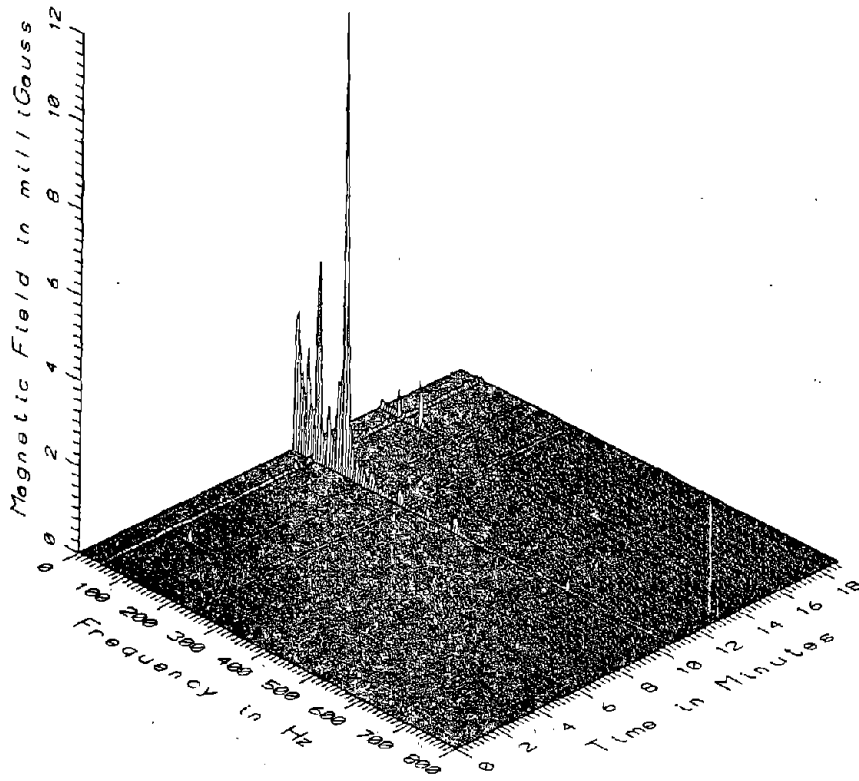

TR7021 - STATION PLATFORM - 5.5M EAST OF GUIDEWAY, 1M ABOVE PLATFORM

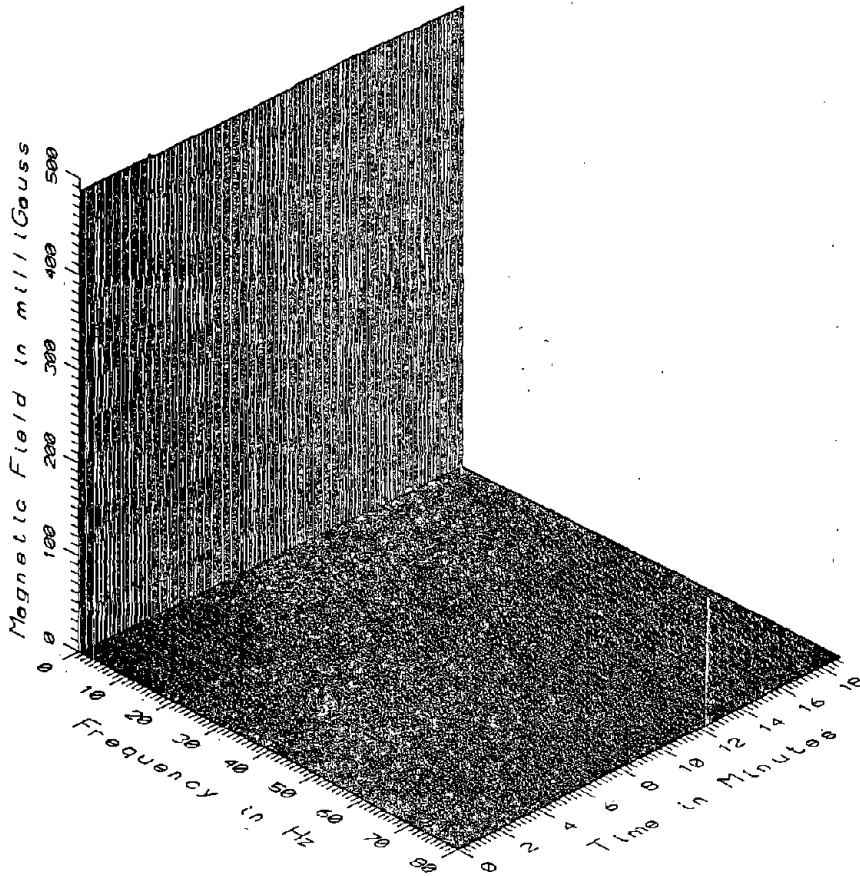

TR7021 - STATION PLATFORM - 9M WEST OF GUIDEWAY, 1M ABOVE GROUND

Q-5

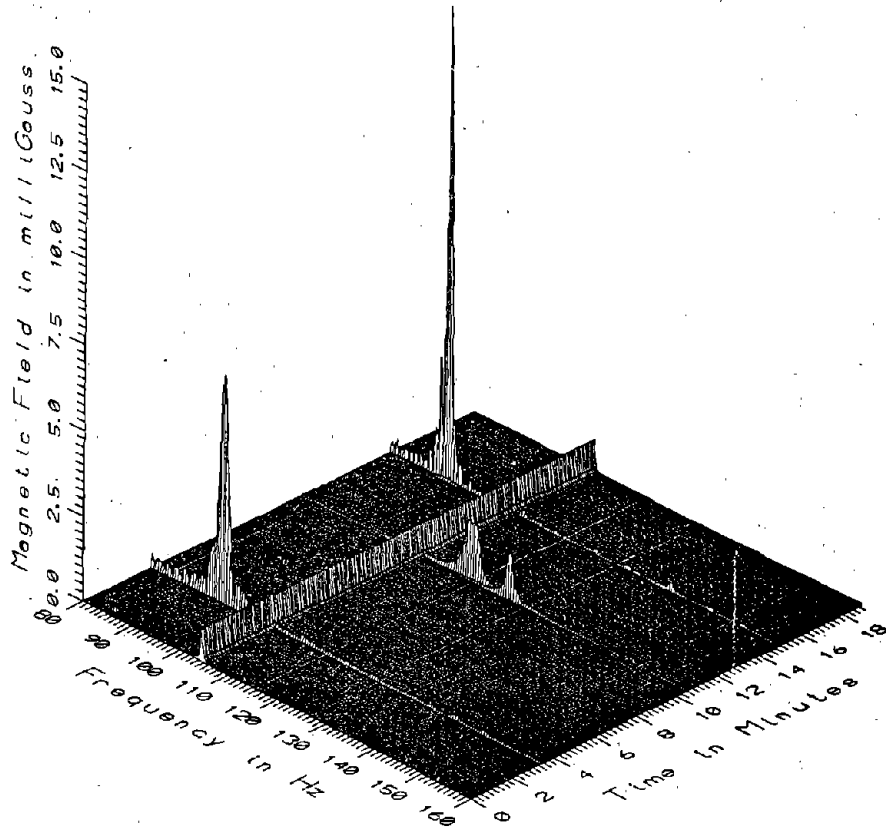

TR7021 - STATION PLATFORM - 9M WEST OF GUIDEWAY, 1M ABOVE GROUND

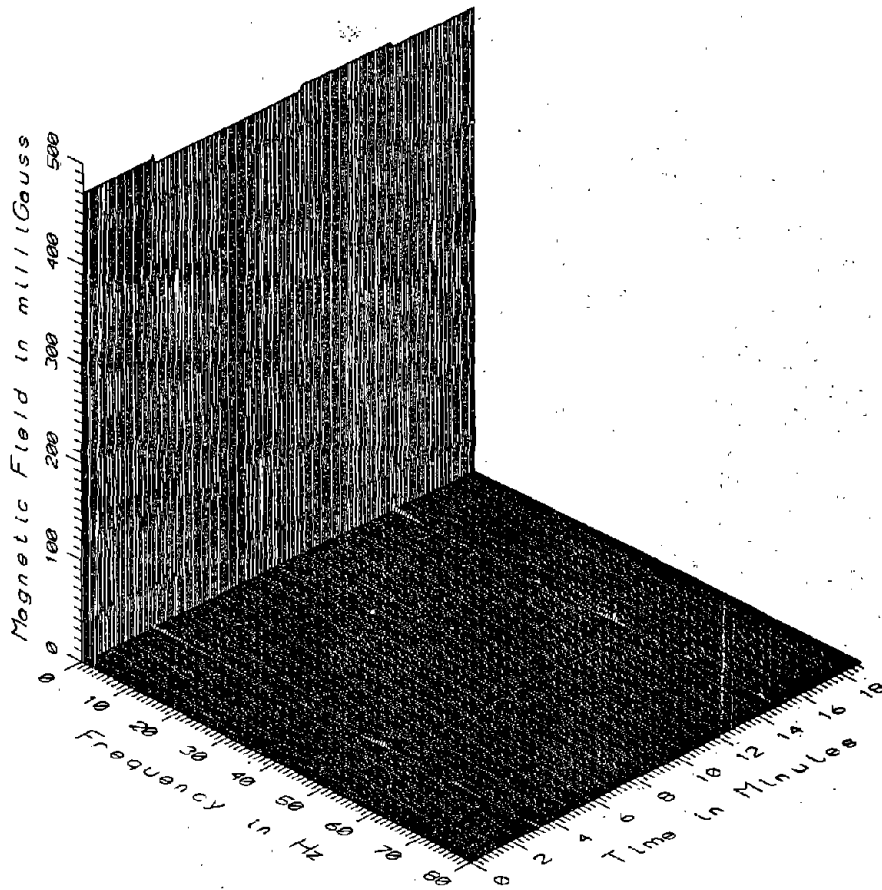

TR7021 - STATION PLATFORM - 3M WEST OF GUIDEWAY, 1M ABOVE GROUND

Q-6

Q-7

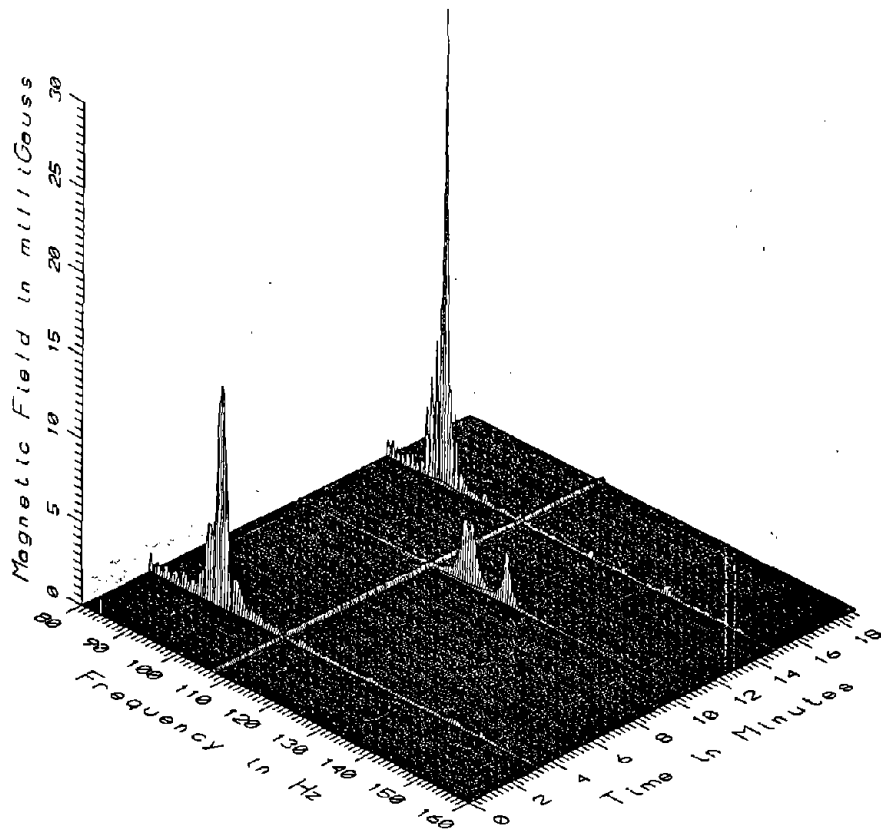

TR7021 - STATION PLATFORM - 3M WEST OF GUIDEWAY, 1M ABOVE GROUND

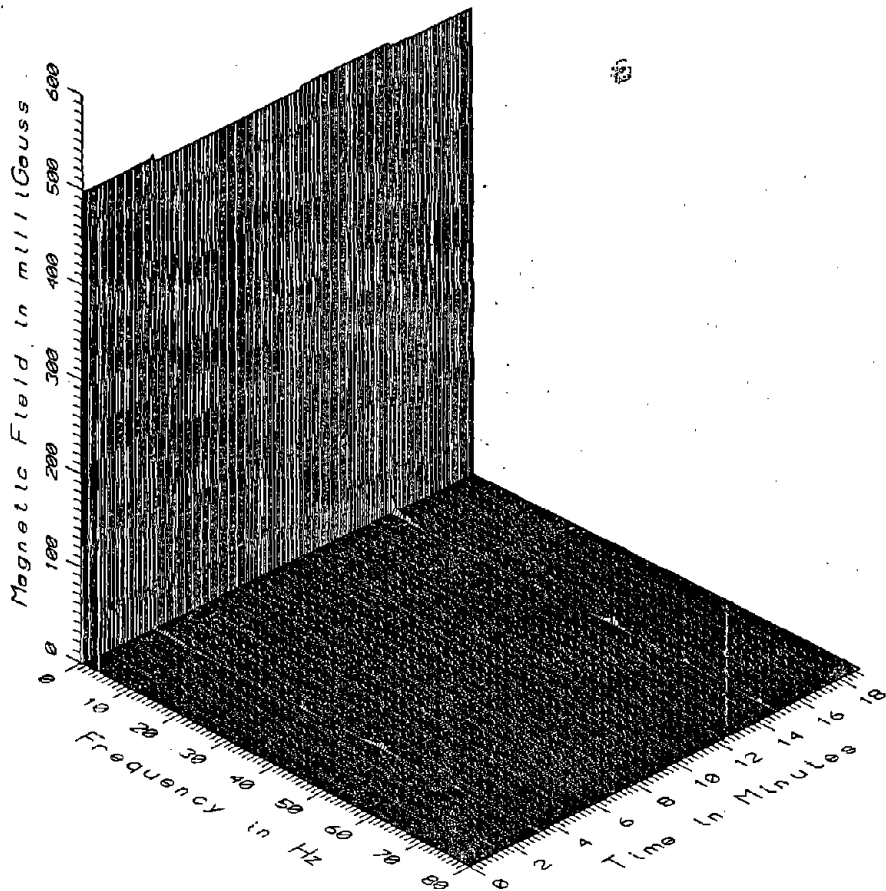

TR7021 - STATION PLATFORM - CENTER OF GUIDEWAY, 1M ABOVE GROUND

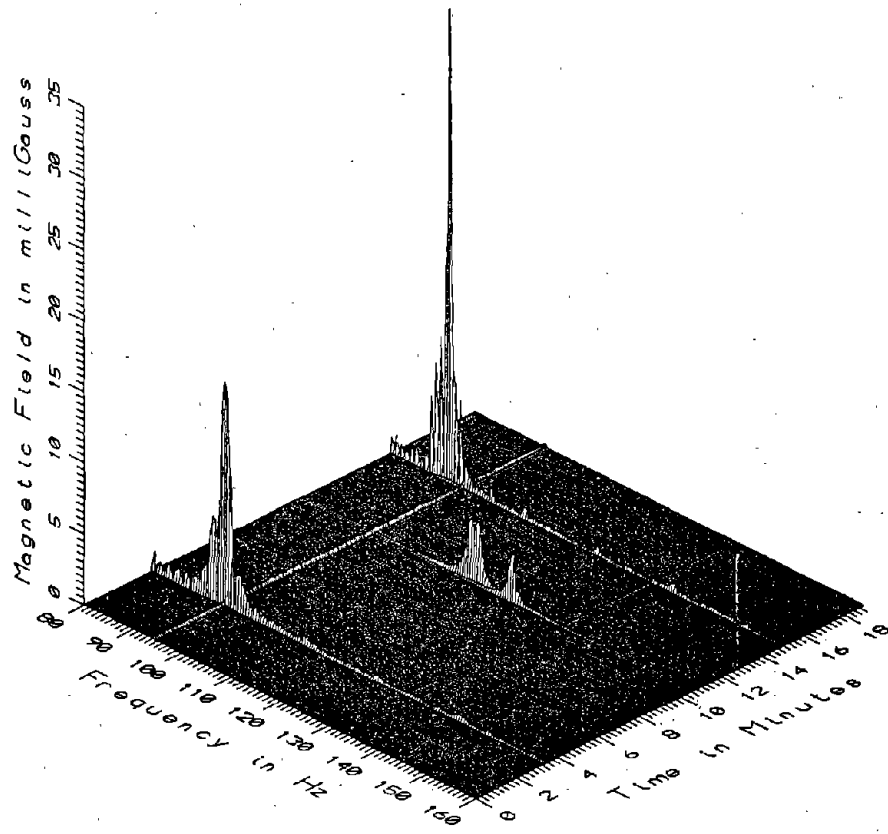

TR7021 - STATION PLATFORM - CENTER OF GUIDEWAY, 1M ABOVE GROUND

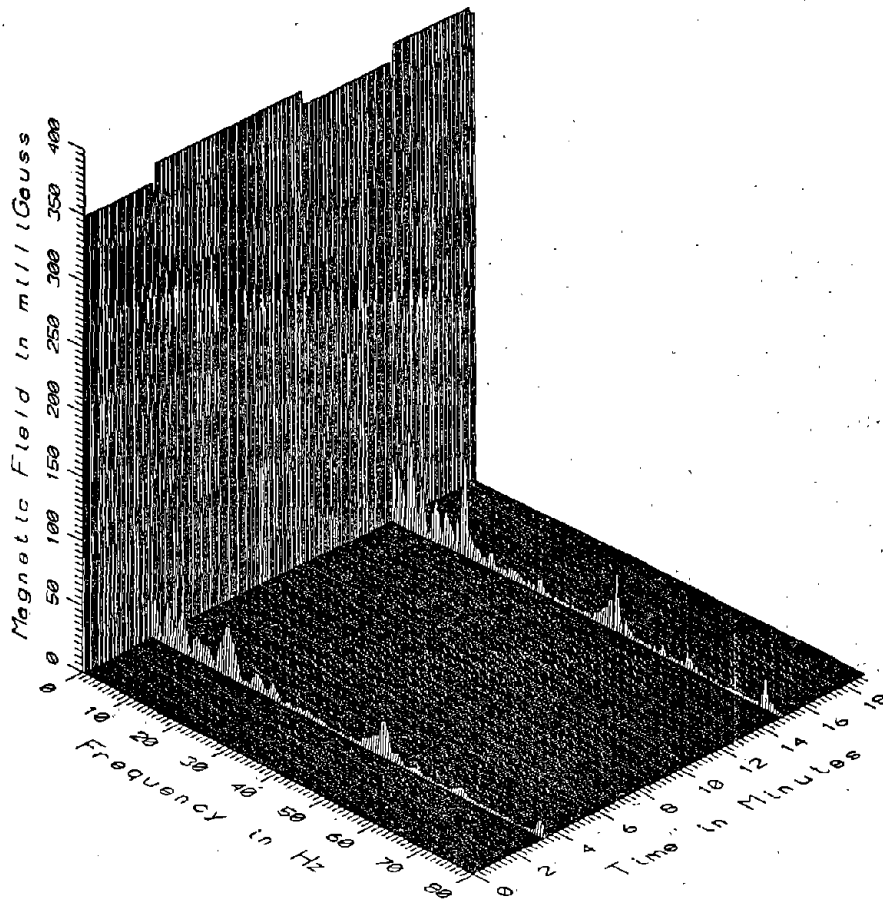

TR7021 - STATION PLATFORM 2.5M EAST OF GUIDEWAY, PLATFORM LEVEL

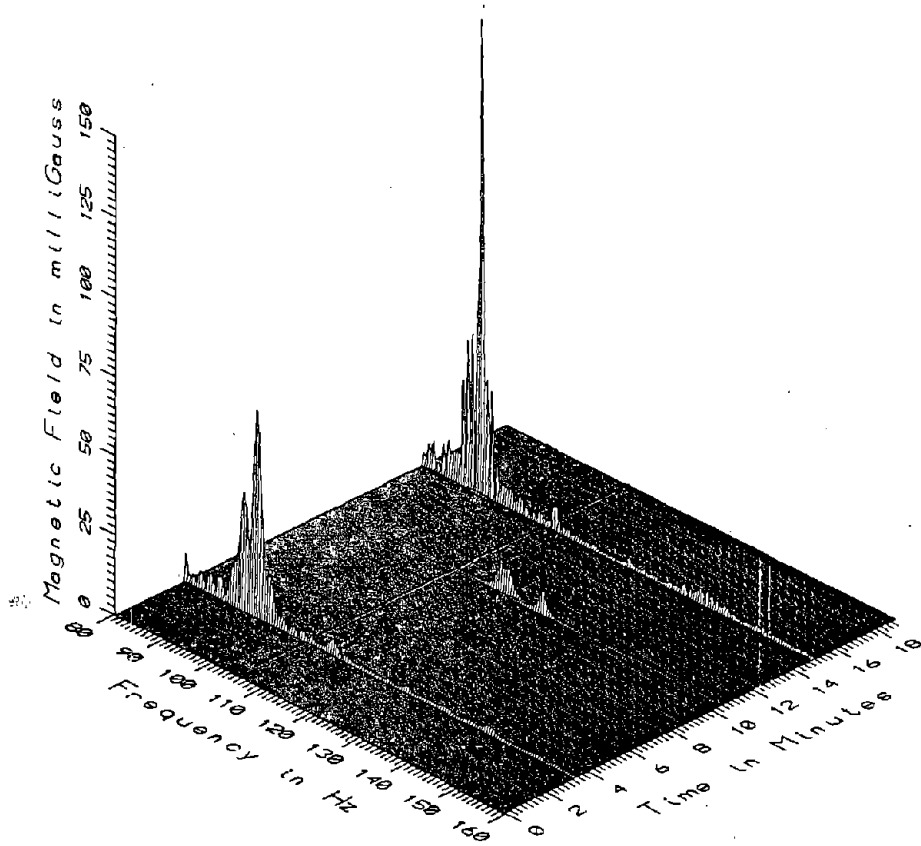

TR7021 - STATION PLATFORM - 2.5M EAST OF GUIDEWAY, PLATFORM LEVEL

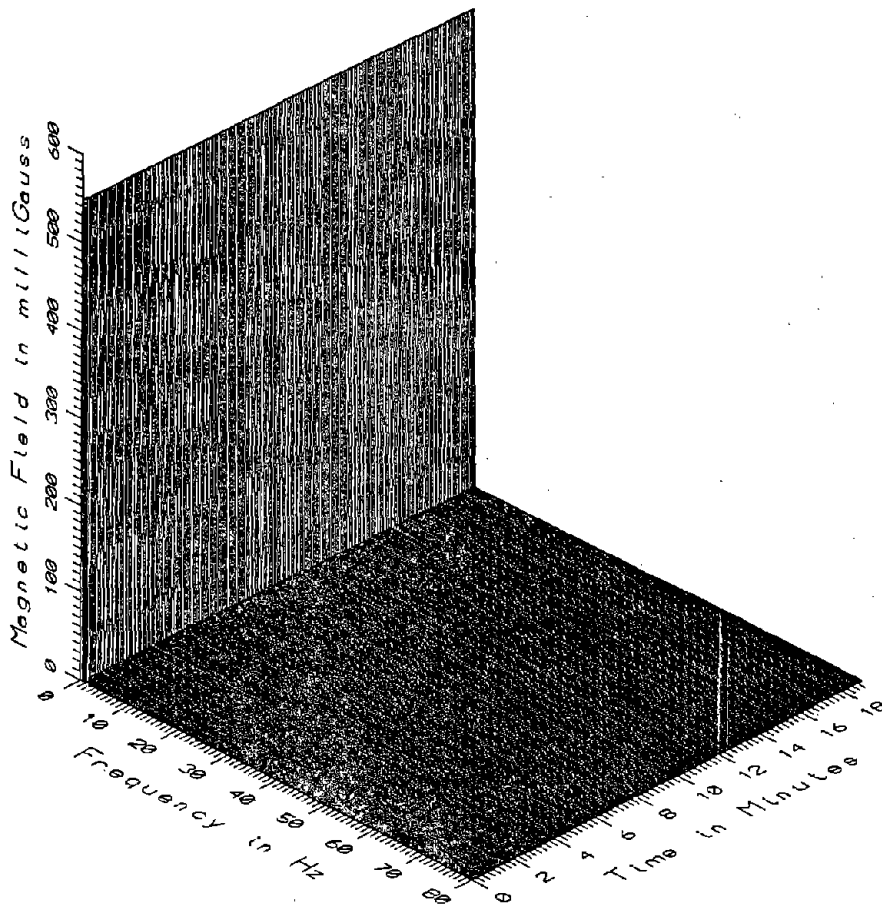

TR7021 - STATION PLATFORM - 5.5M EAST OF GUIDEWAY, 1M ABOVE PLATFORM

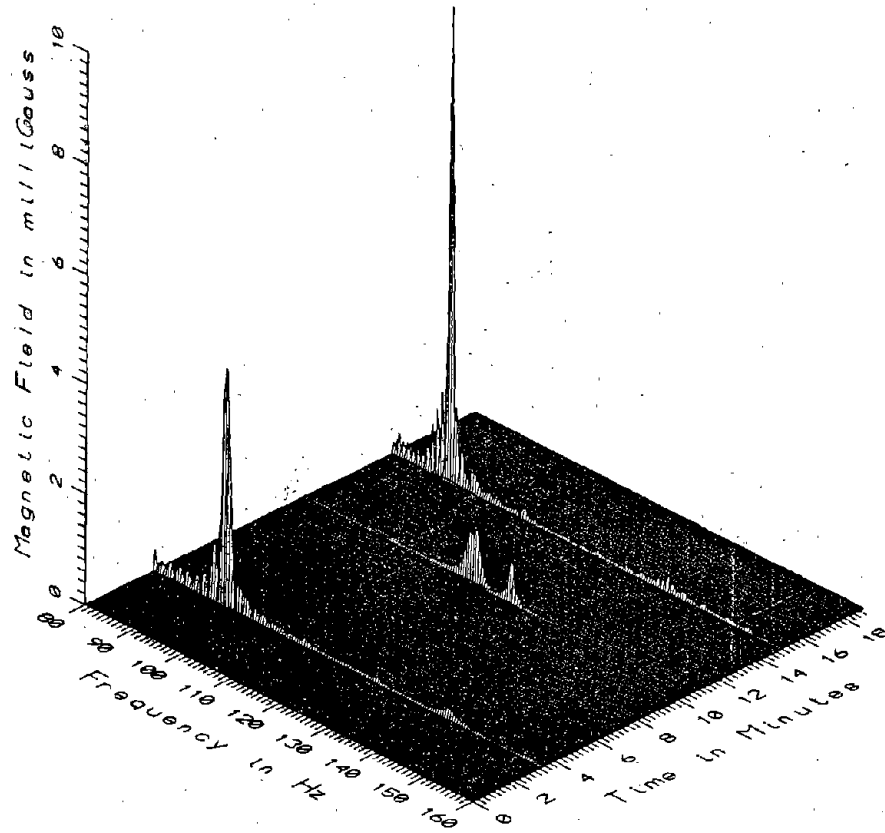

TR7021 - STATION PLATFORM - 5.5M EAST OF GUIDEWAY, 1M ABOVE PLATFORM

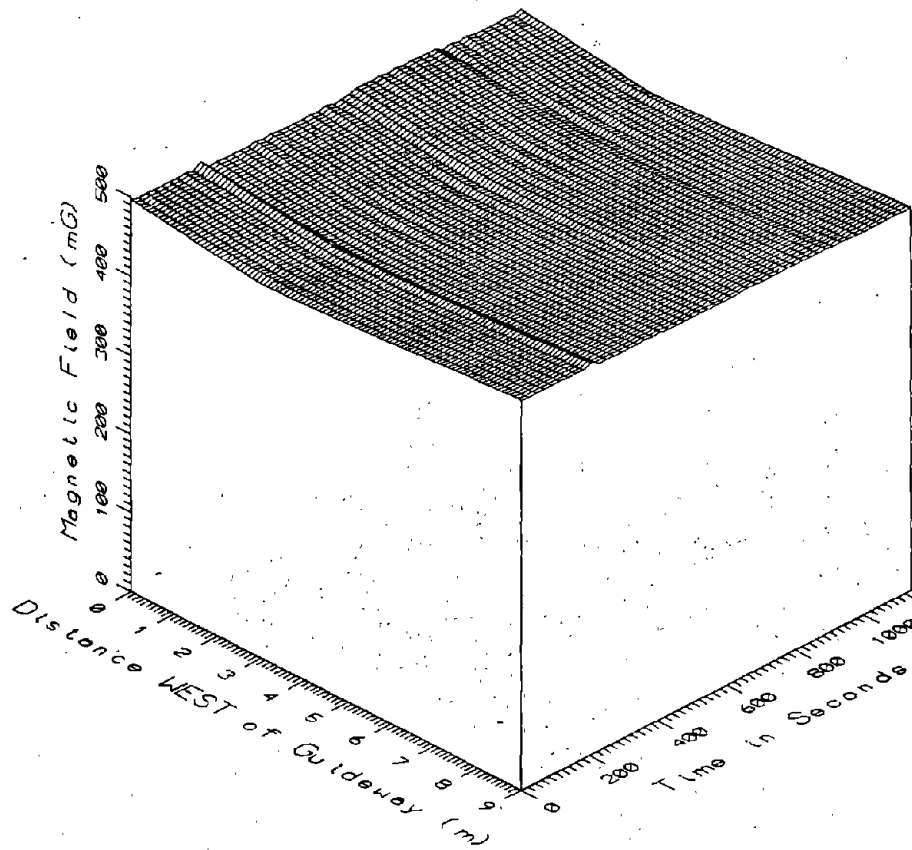

TR7021, GUIDEWAY AT LOADING PLATFORM - DC

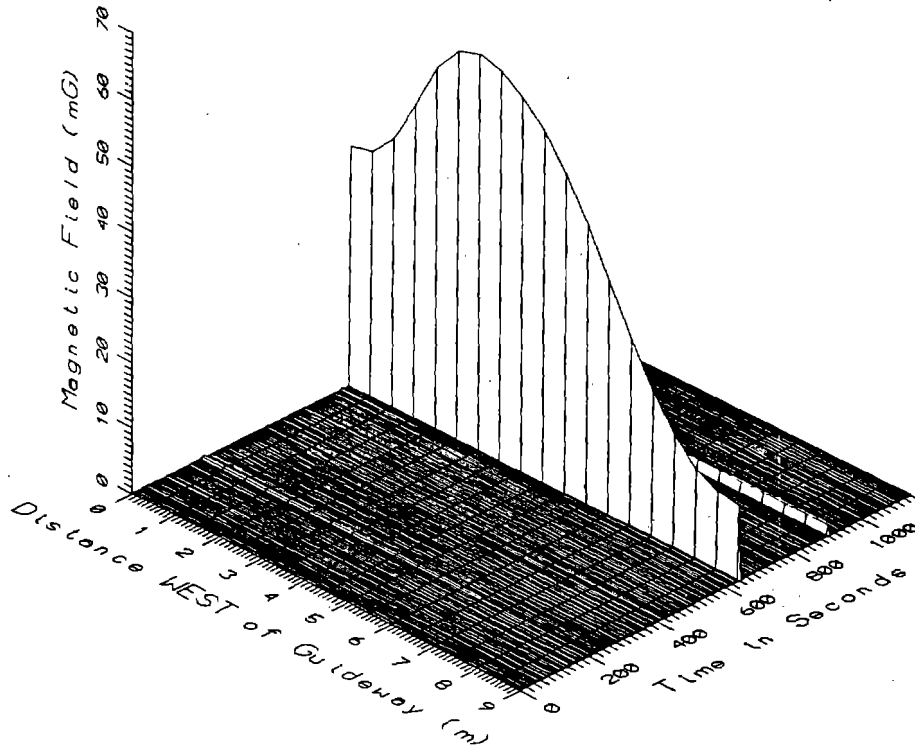

TR7021, GUIDEWAY AT LOADING PLATFORM - LOW FREQUENCY, 5-45Hz

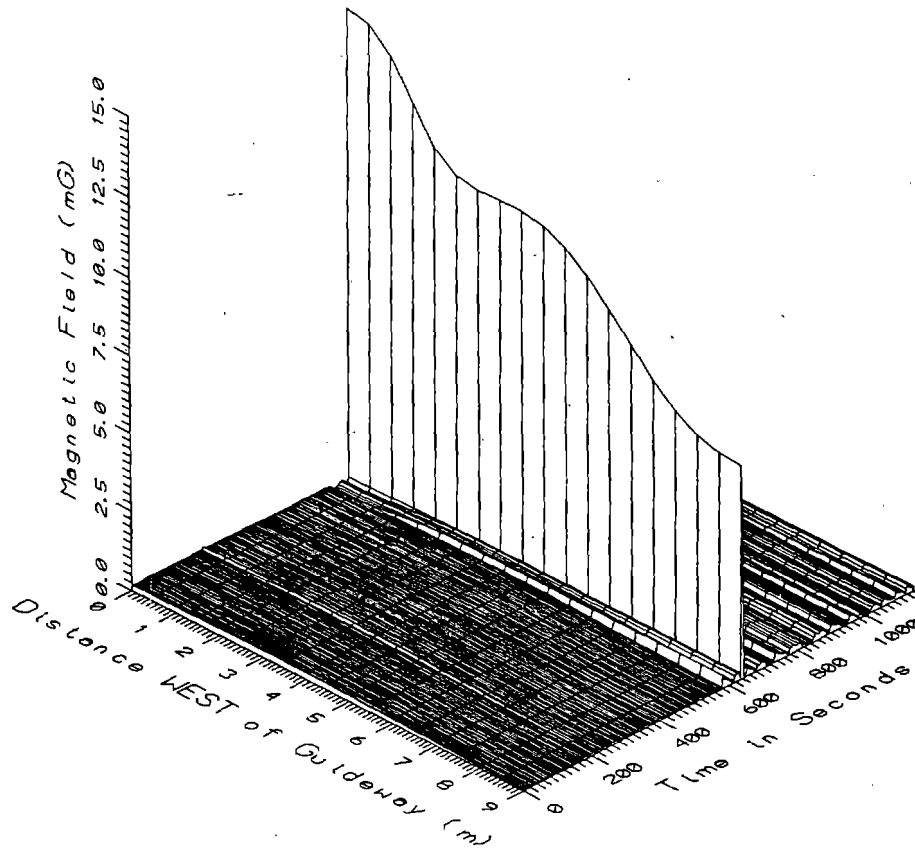

TR7021, GUIDEWAY AT LOADING PLATFORM - POWER FREQUENCY, 50-60Hz

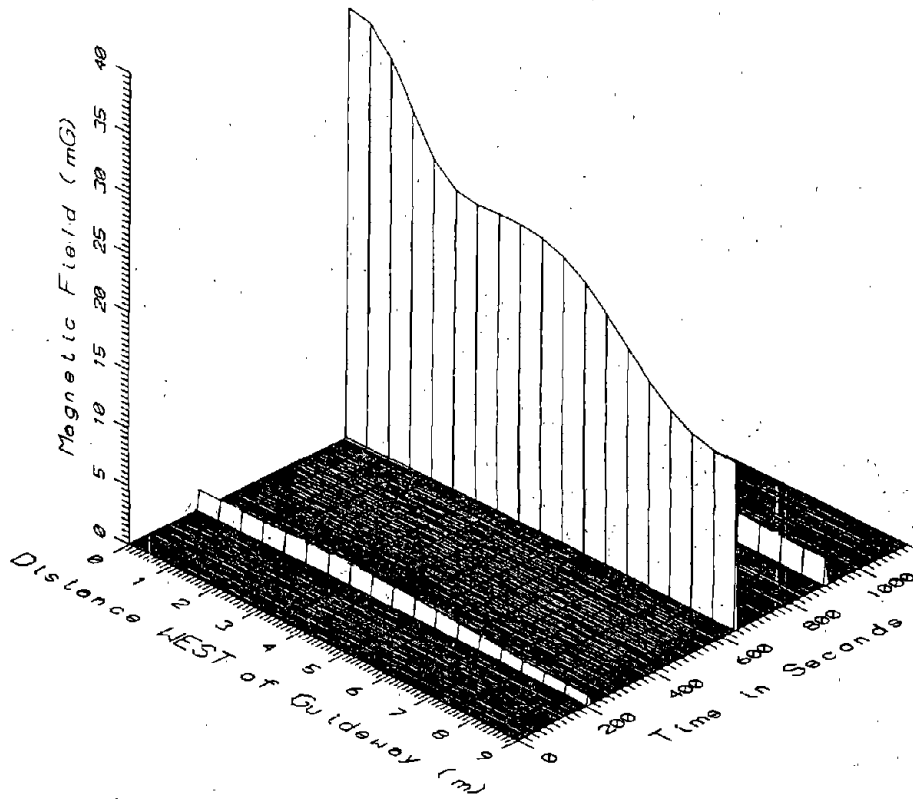

TR7021, GUIDEWAY AT LOADING PLATFORM - POWER HARMONICS, 65-300Hz

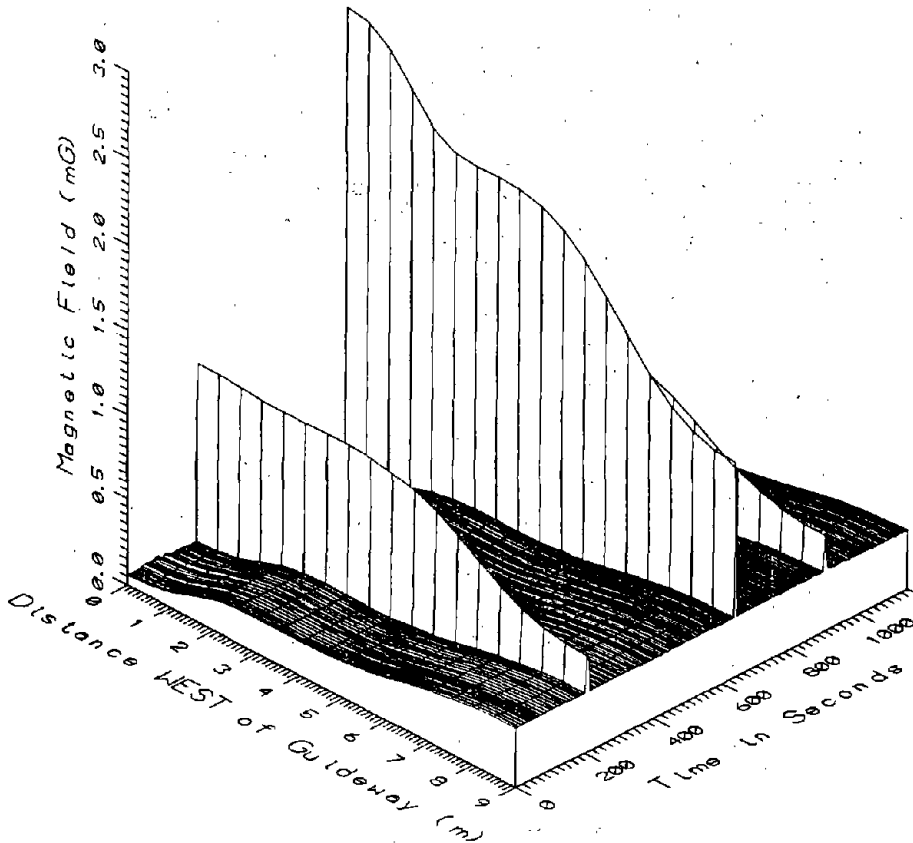

TR7021, GUIDEWAY AT LOADING PLATFORM - HIGH FREQUENCY, 305-2560Hz

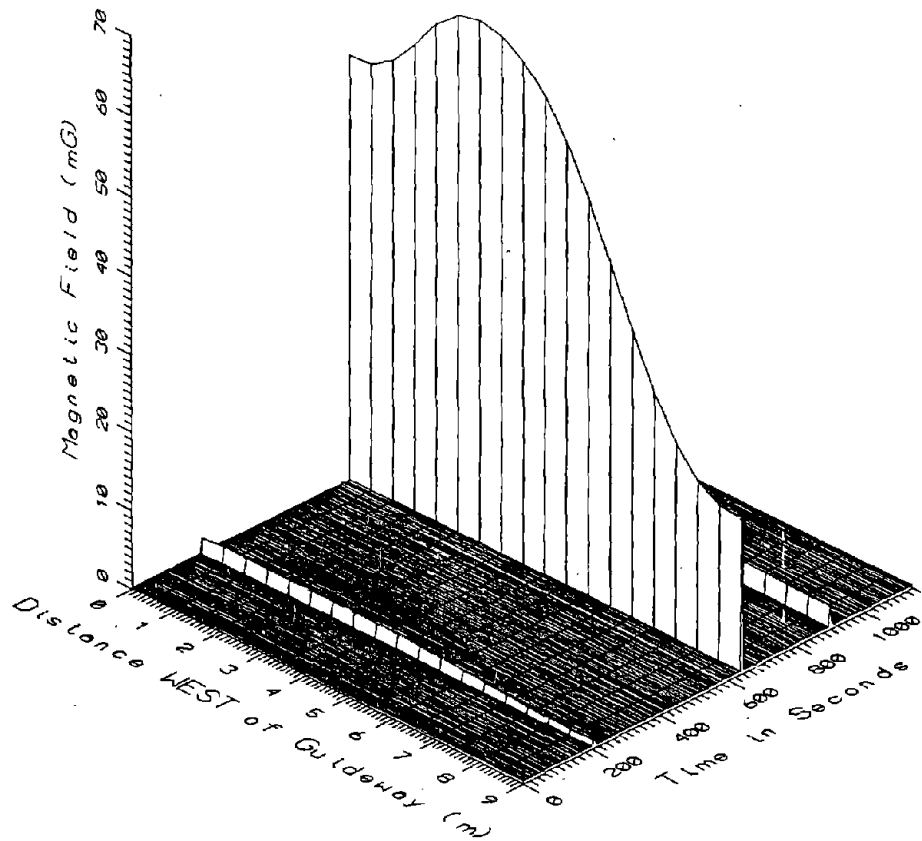

TR7021, GUIDEWAY AT LOADING PLATFORM - ALL FREQUENCIES, 5-2560Hz

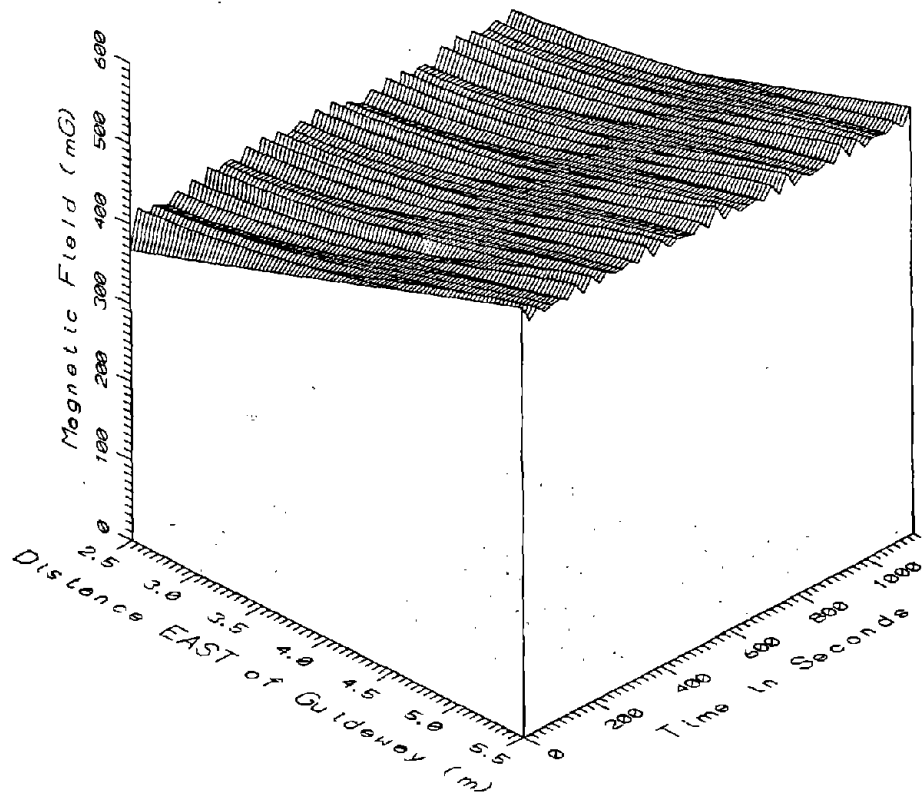

TR7021, GUIDEWAY AT LOADING PLATFORM - DC

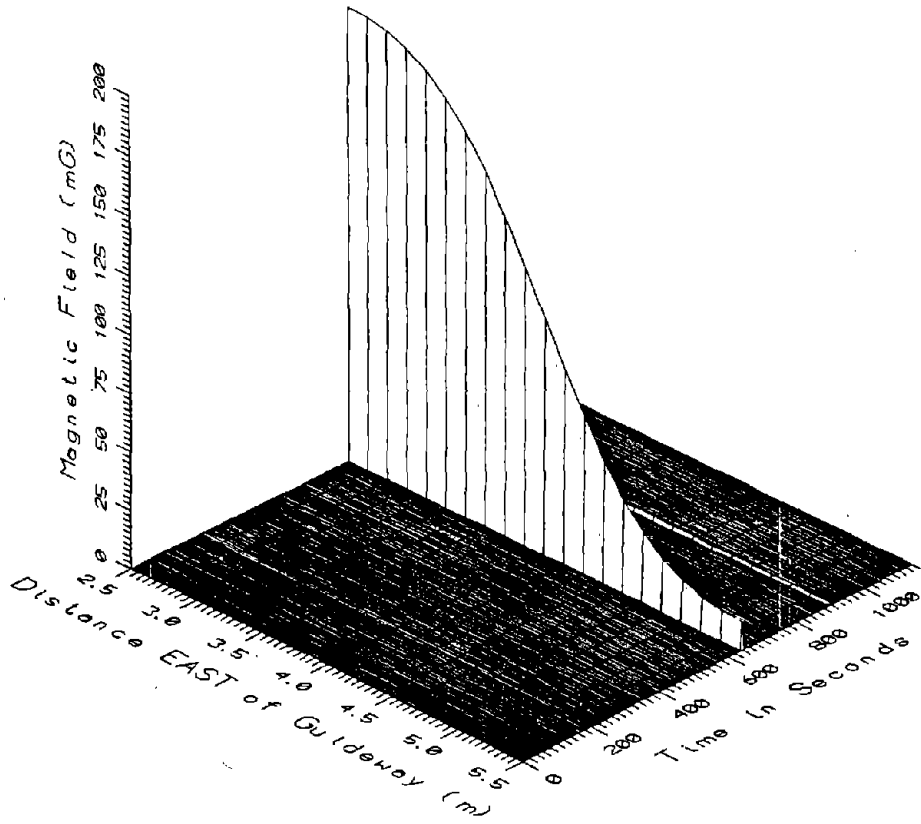

TR7021. GUIDEWAY AT LOADING PLATFORM - LOW FREQUENCY, 5-45Hz

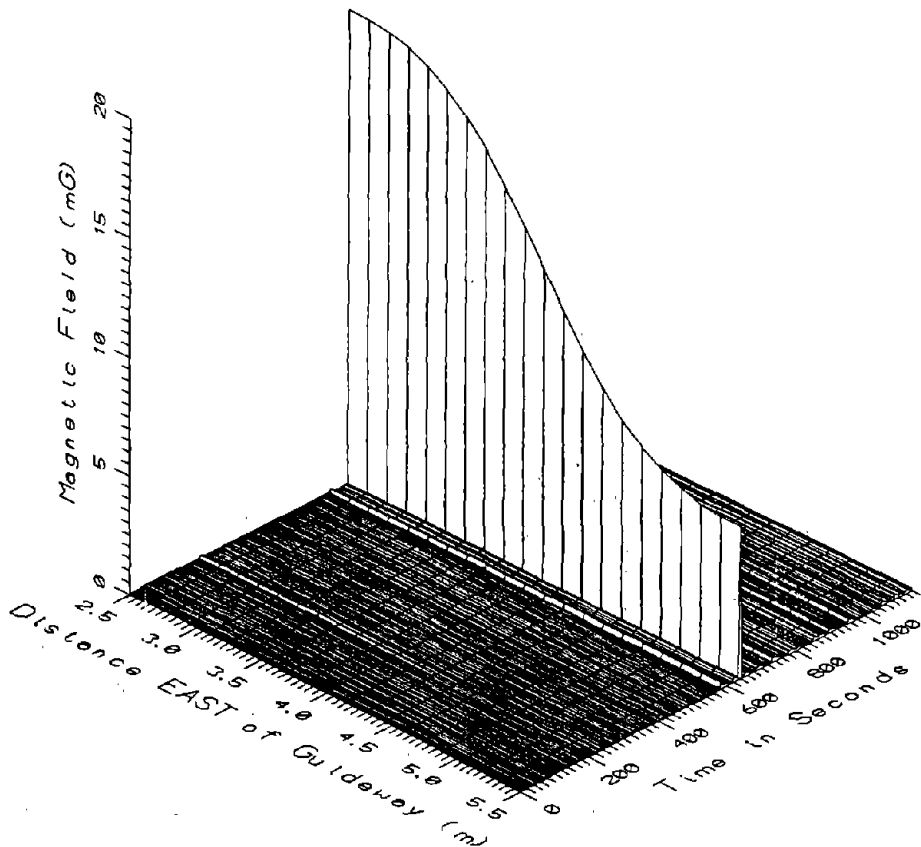

TR7021. GUIDEWAY AT LOADING PLATFORM - POWER FREQUENCY, 50-60Hz

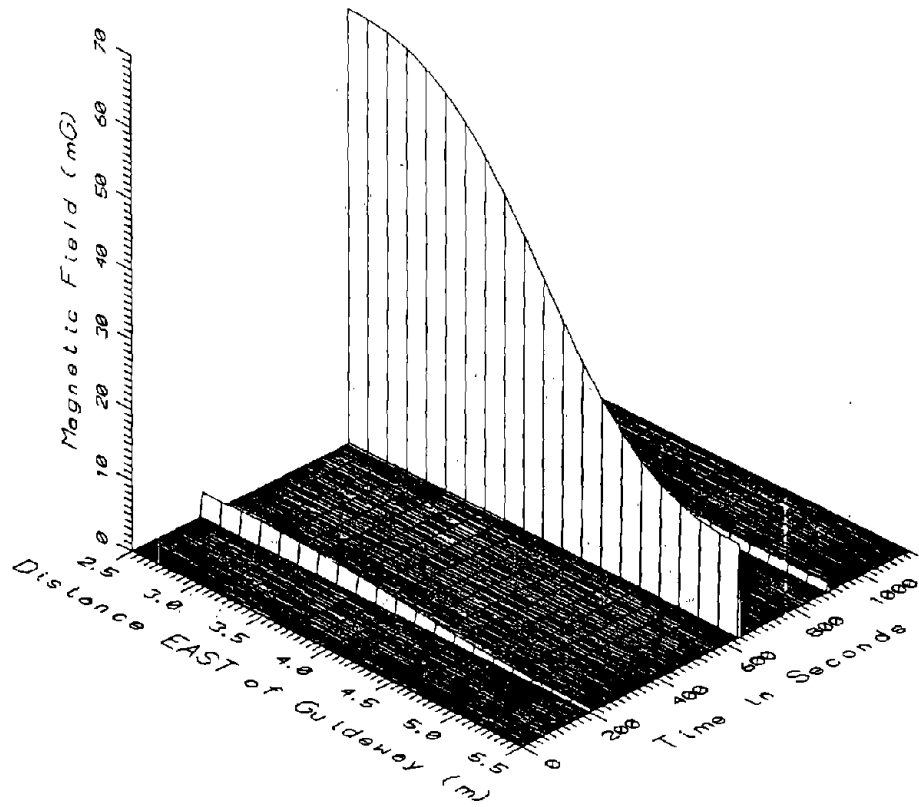

TR7021, GUIDEWAY AT LOADING PLATFORM - POWER HARMONICS, 65-300Hz

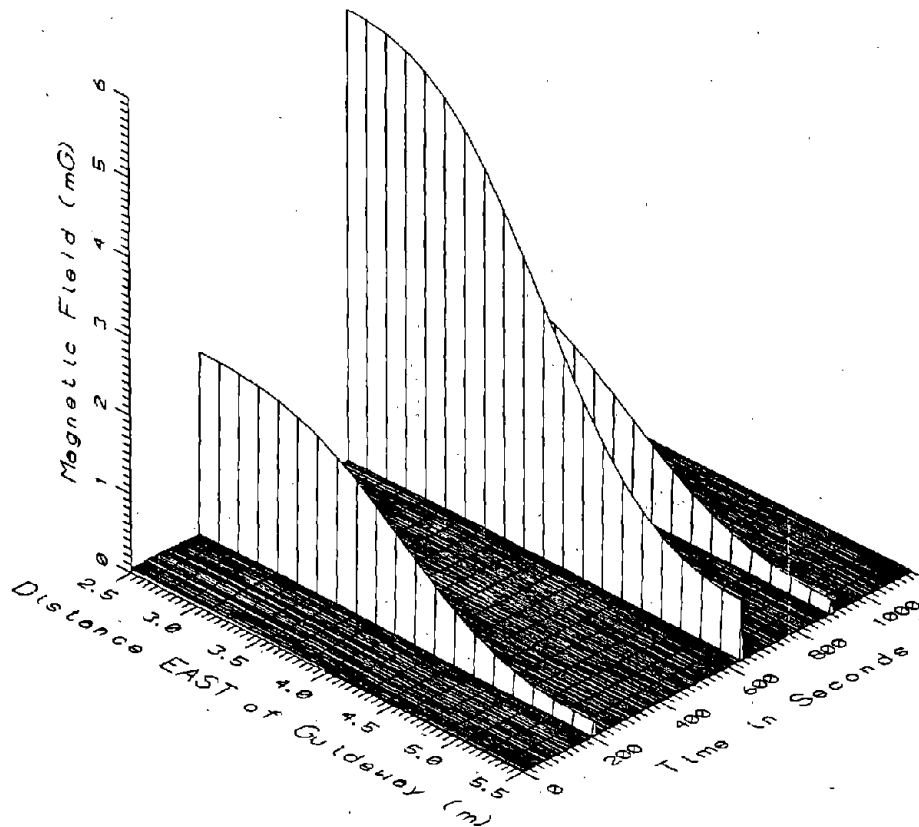

TR7021, GUIDEWAY AT LOADING PLATFORM - HIGH FREQUENCY, 305-2560Hz

Q-16

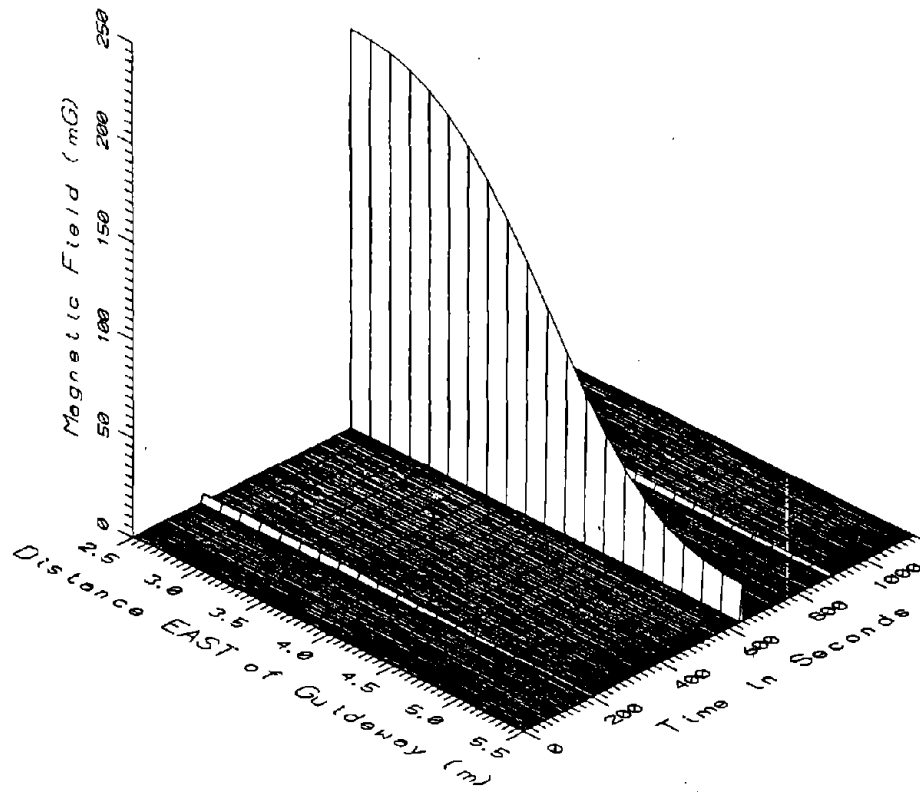

TR7021, GUIDEWAY AT LOADING PLATFORM - ALL FREQUENCIES, 5-2560Hz

R-1

APPENDIX R

DATA SET TR7022

MEASUREMENTS NEAR THE TRANSFORMER YARD

APPENDIX R

DATA SET TR7022
MEASUREMENTS NEAR THE TRANSFORMER YARD

Measurement Setup Code: 22
 Vehicle Status: Running continuously
 Measurement Date: August 9, 1990
 Measurement Time: Start: 15:08:00
 End: 15:28:00
 Number of Samples: 230
 Programmed Sample Interval: 4 sec
 Actual Sample Interval: 5.2 sec

Frequency Spectrum Parameters

<u>Probe Type:</u>	<u>Coil (AC)</u>	<u>Fluxgate (DC)</u>
Maximum Frequency (Hz)	2560	256
Minimum Frequency (Hz)	5	0
Spectral Bandwidth (Hz)	5	0.5

Missing or Suspect Data: The fluxgate probes 3 m and 10 m from the transformer yard were inoperative.

SETUP 22: OUTPUT TRANSFORMER YARD

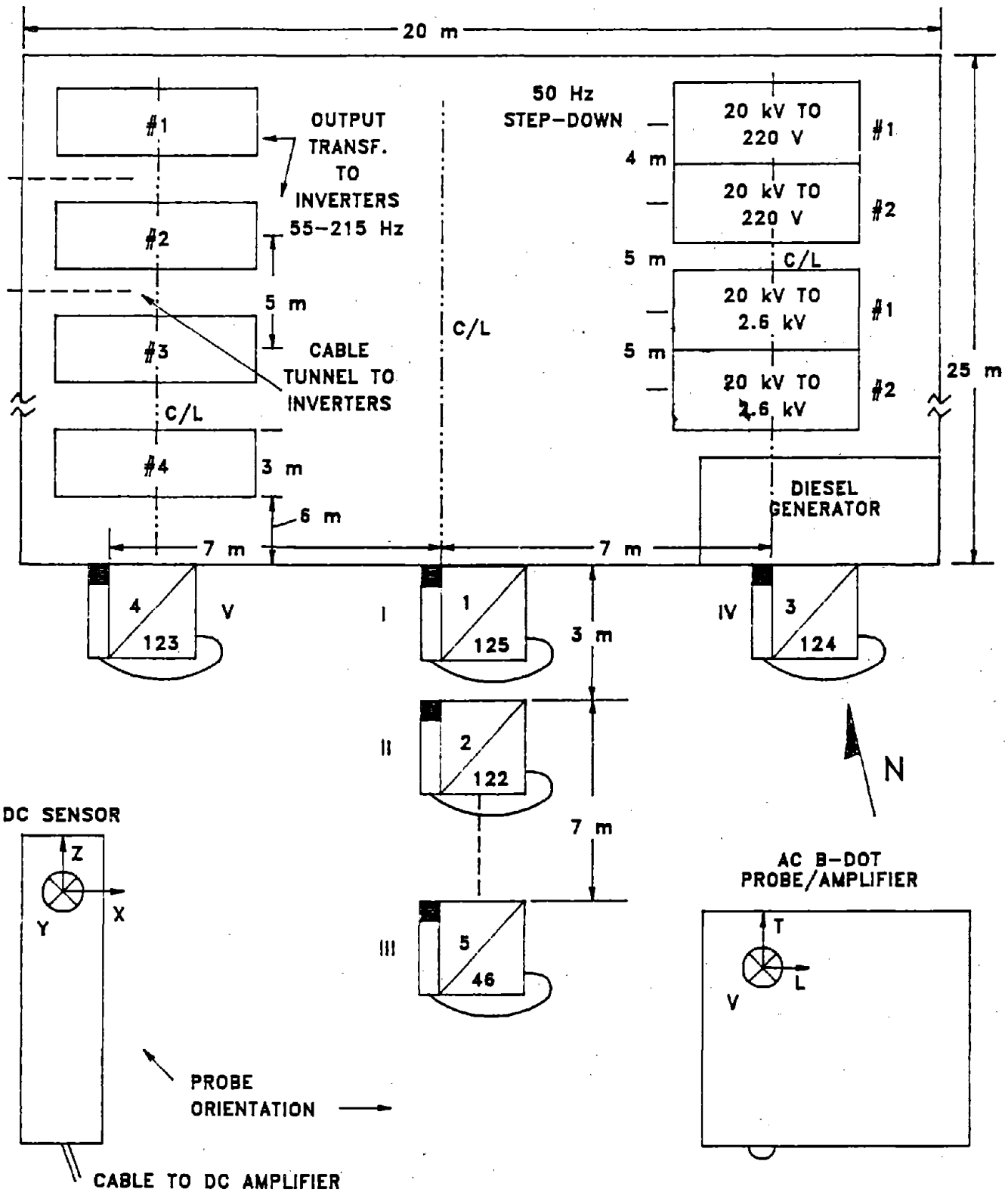

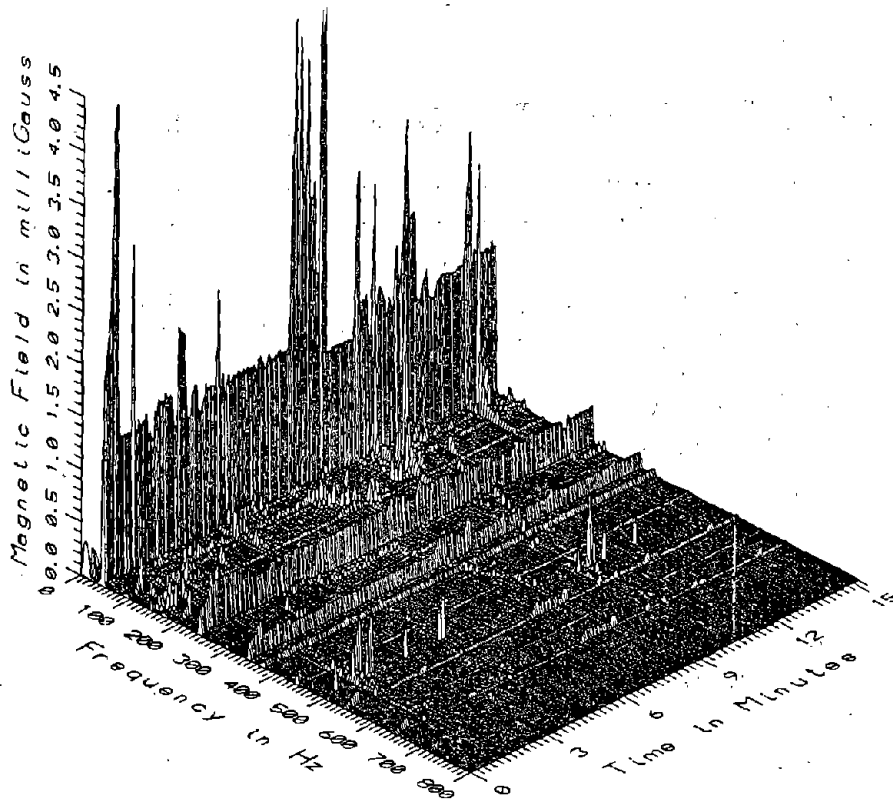

TR7022 - SOUTH EDGE OF OUTPUT TRANSFORMER YARD

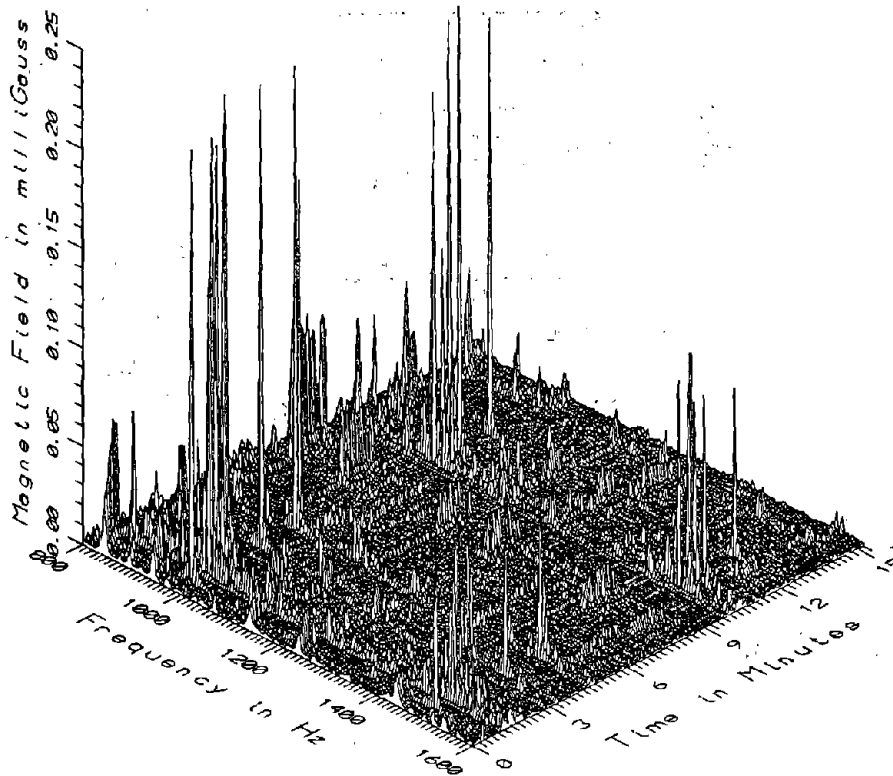

TR7022 - SOUTH EDGE OF OUTPUT TRANSFORMER YARD

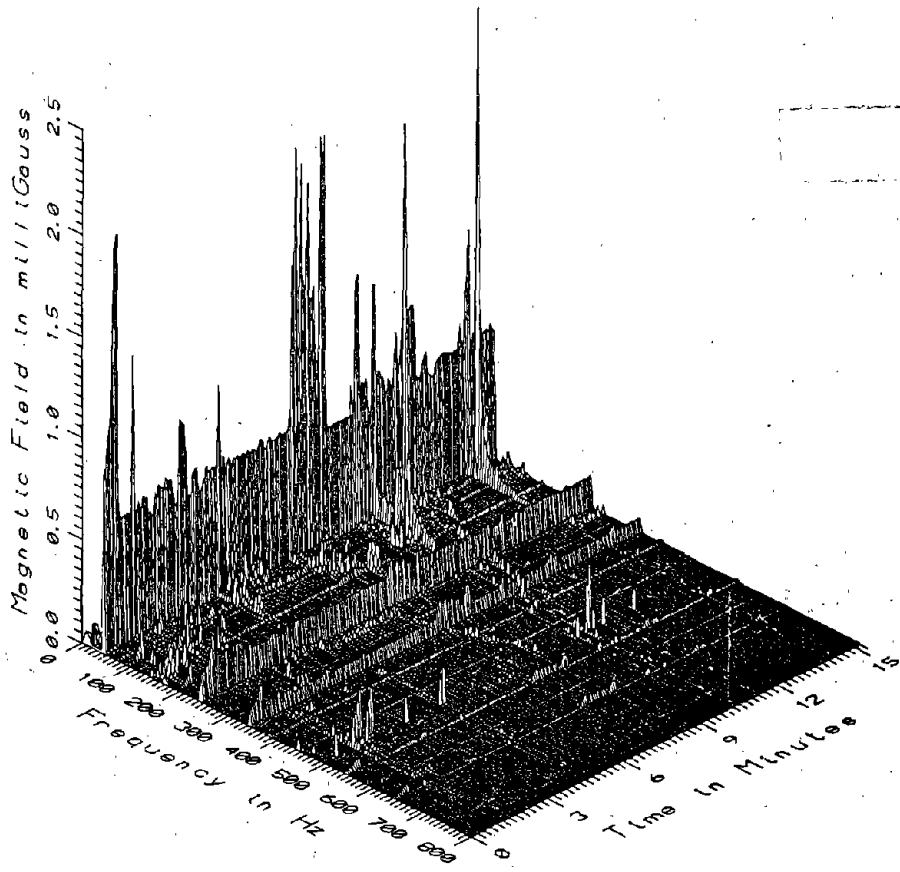

TR7022 - 3M SOUTH OF SOUTH EDGE OF OUTPUT TRANSFORMER YARD

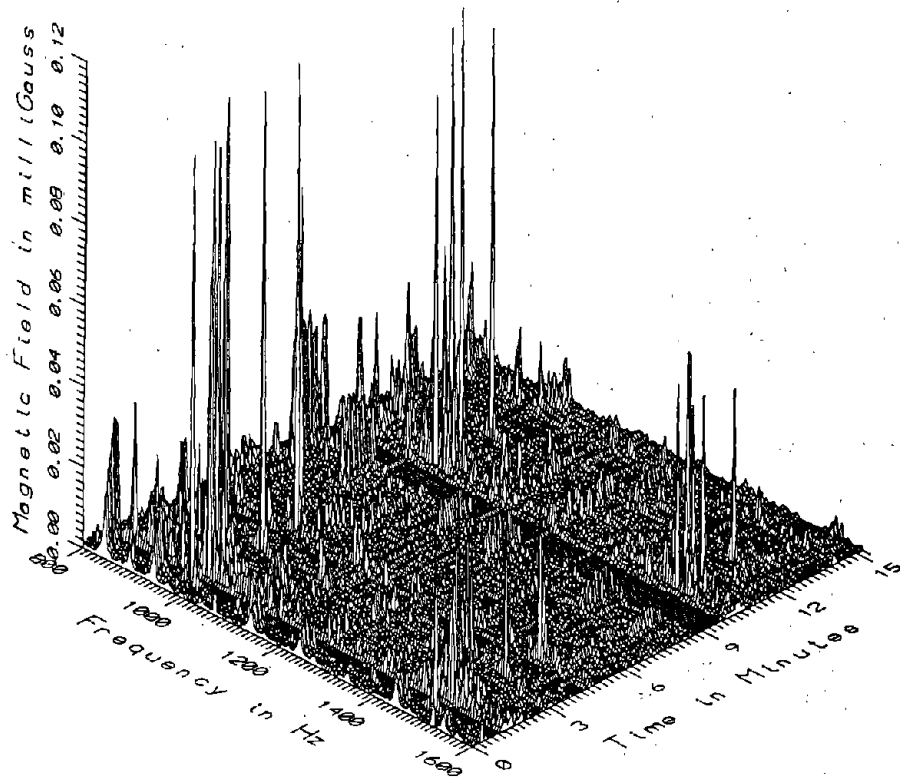

TR7022 - 3M SOUTH OF SOUTH EDGE OF OUTPUT TRANSFORMER YARD

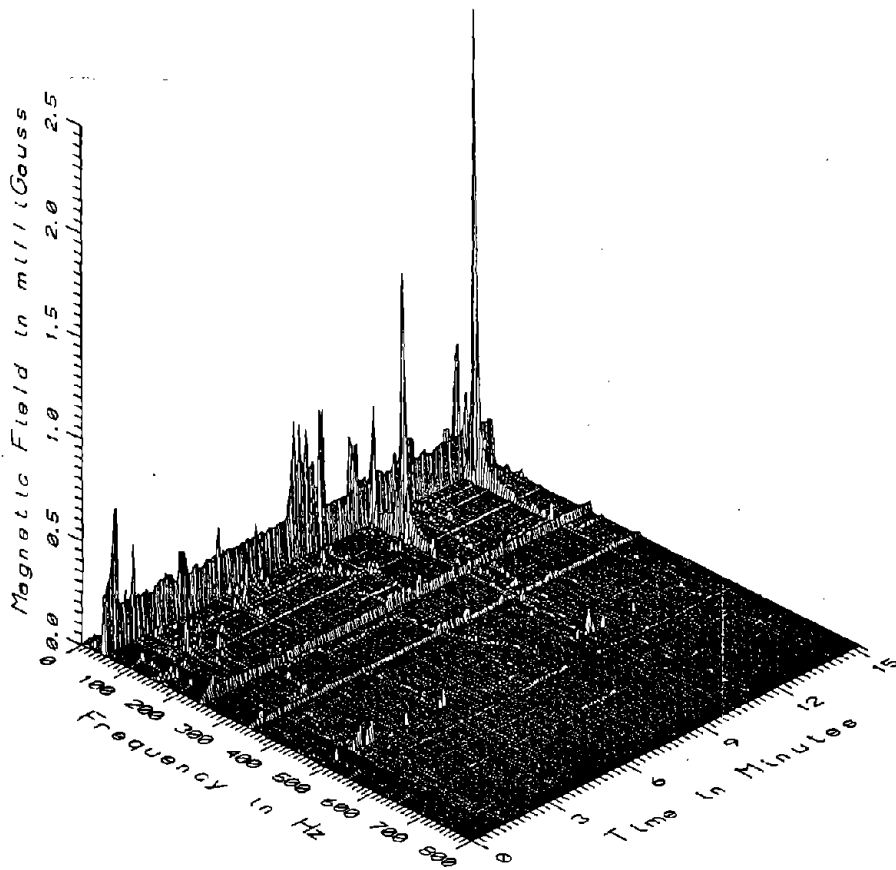

TR7022 - 10M SOUTH OF SOUTH EDGE OF OUTPUT TRANSFORMER YARD

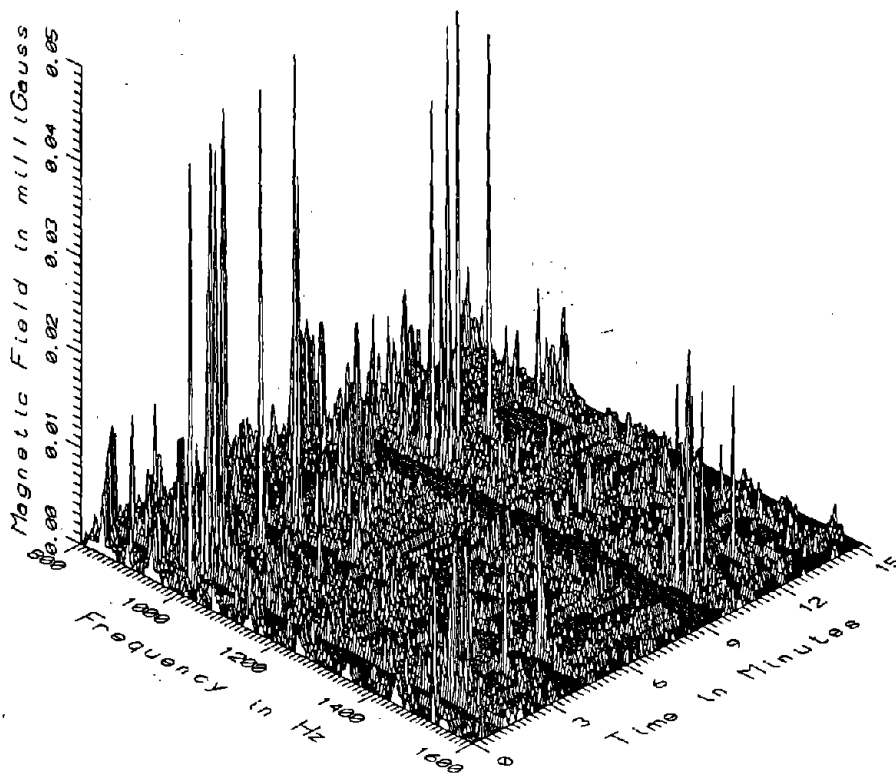

TR7022 - 10M SOUTH OF SOUTH EDGE OF OUTPUT TRANSFORMER YARD

R-5

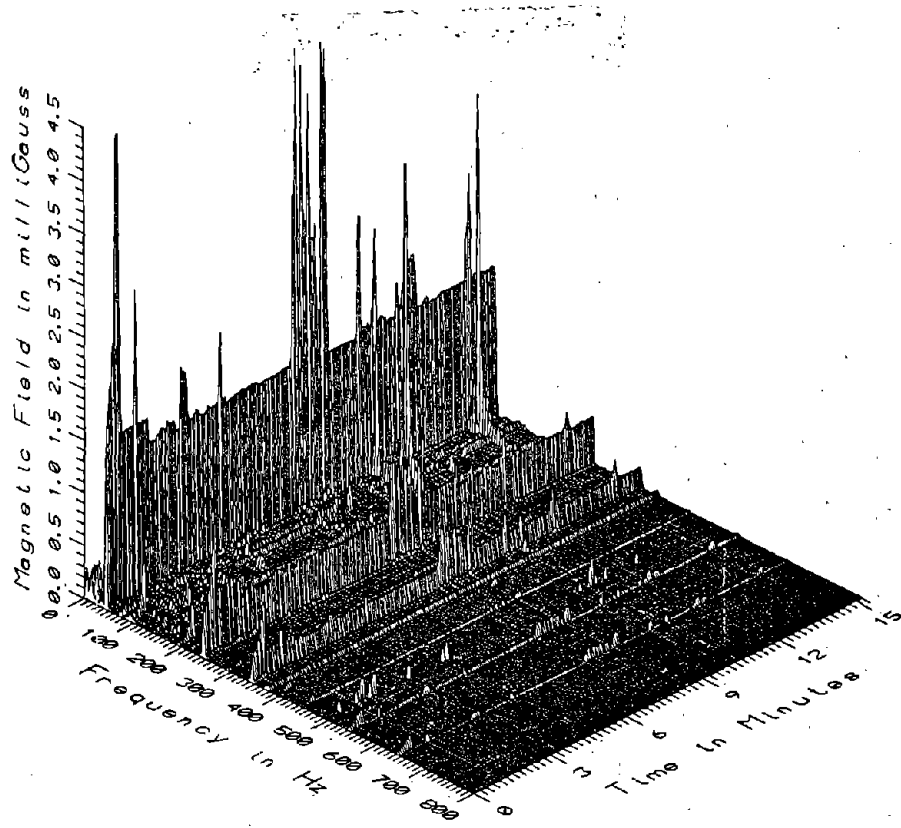

TR7022 - SOUTH EDGE OF OUTPUT TRANSFORMER YARD, 7M EAST OF PROFILE

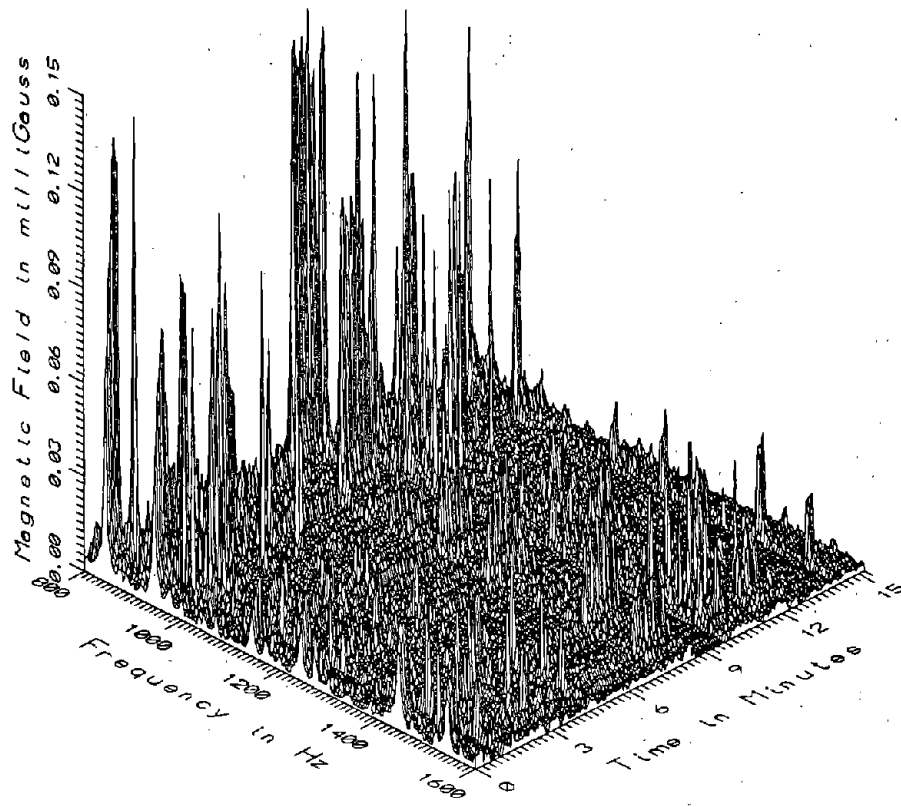

TR7022 - SOUTH EDGE OF OUTPUT TRANSFORMER YARD, 7M EAST OF PROFILE

R-6

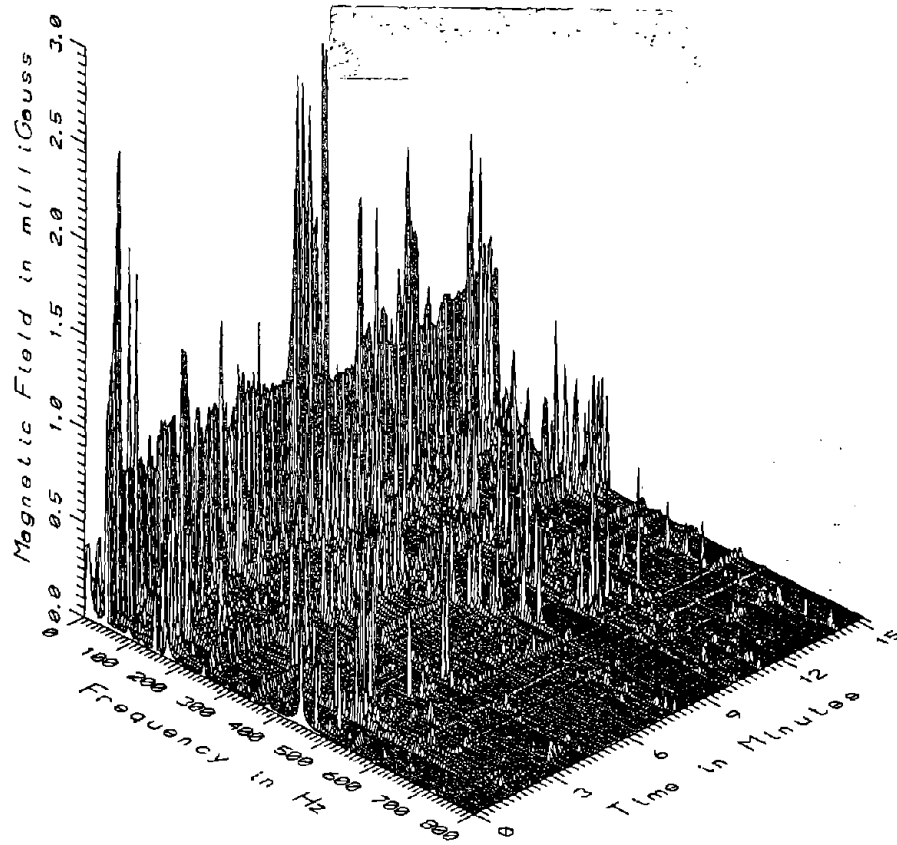

TR7022 - SOUTH EDGE OF OUTPUT TRANSFORMER YARD, 7M WEST OF PROFILE

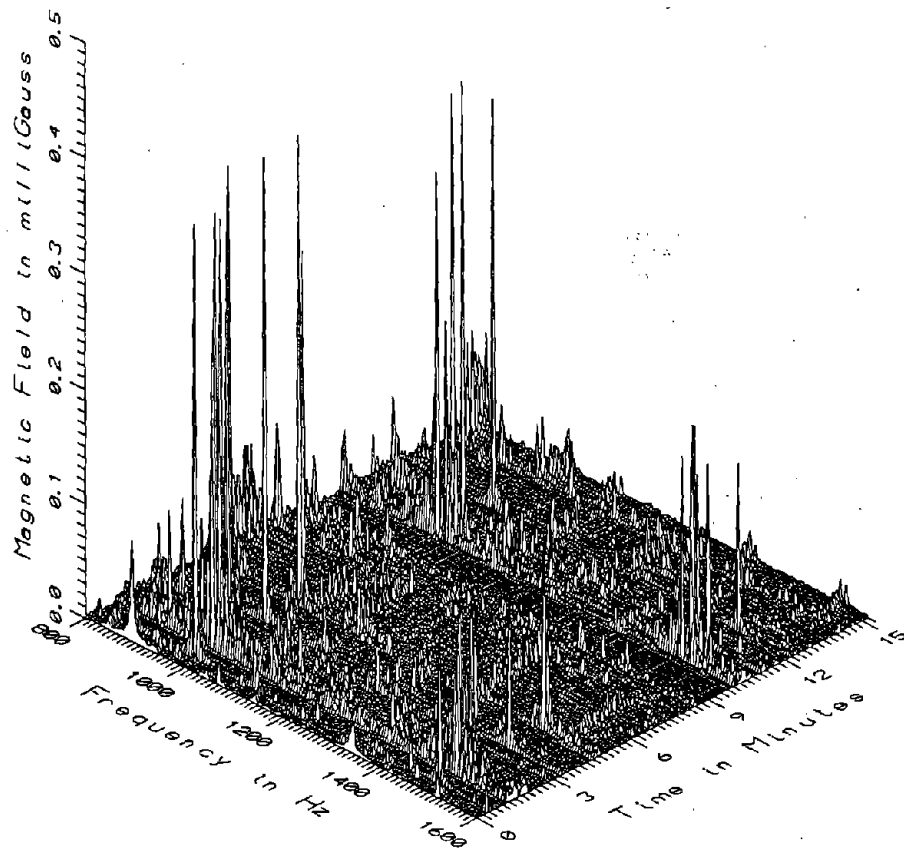

TR7022 - SOUTH EDGE OF OUTPUT TRANSFORMER YARD, 7M WEST OF PROFILE

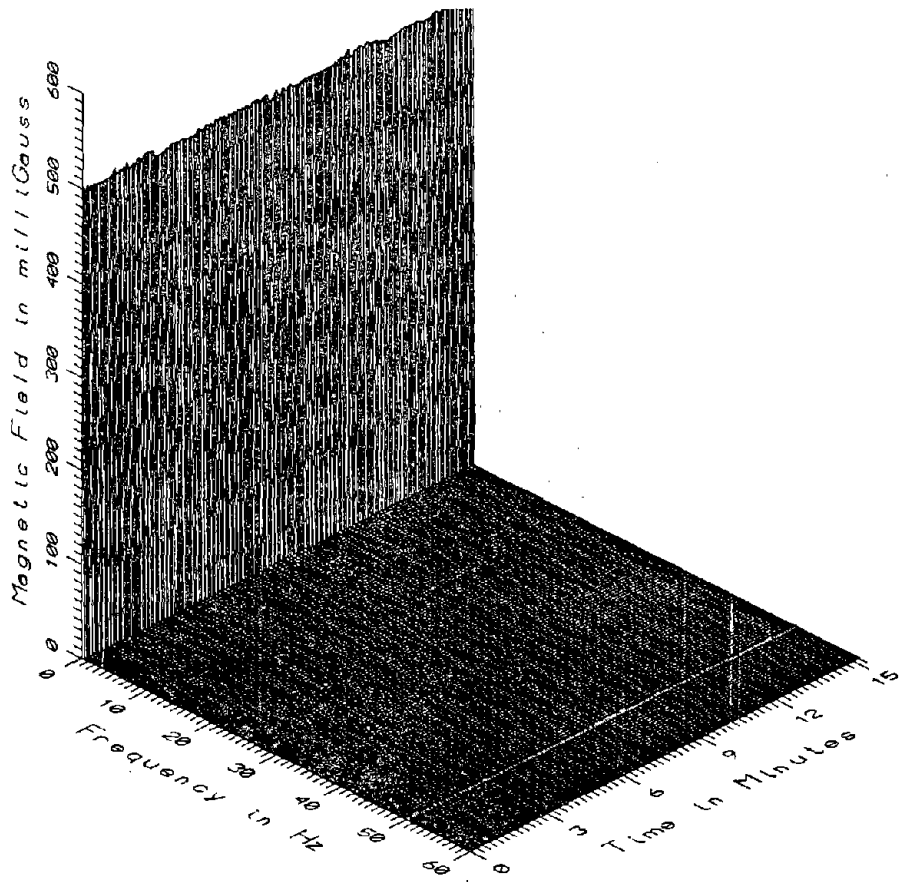

TR7022 - SOUTH EDGE OF OUTPUT TRANSFORMER YARD

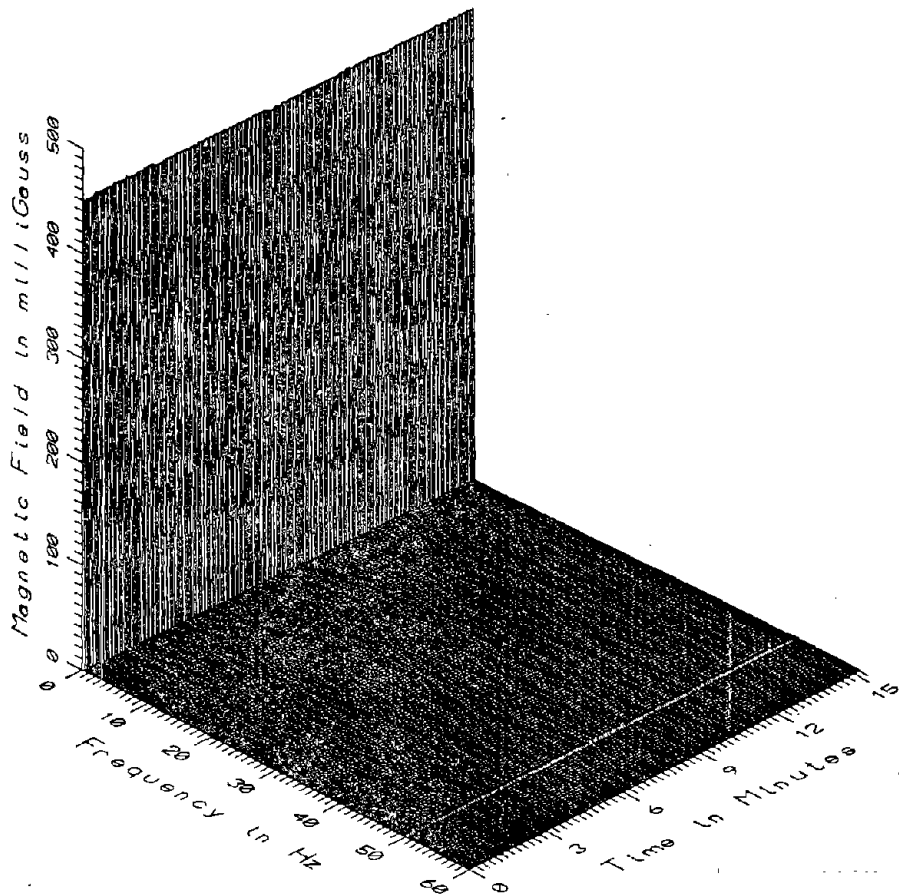

TR7022 - SOUTH EDGE OF OUTPUT TRANSFORMER YARD, 7M EAST OF PROFILE

R-8

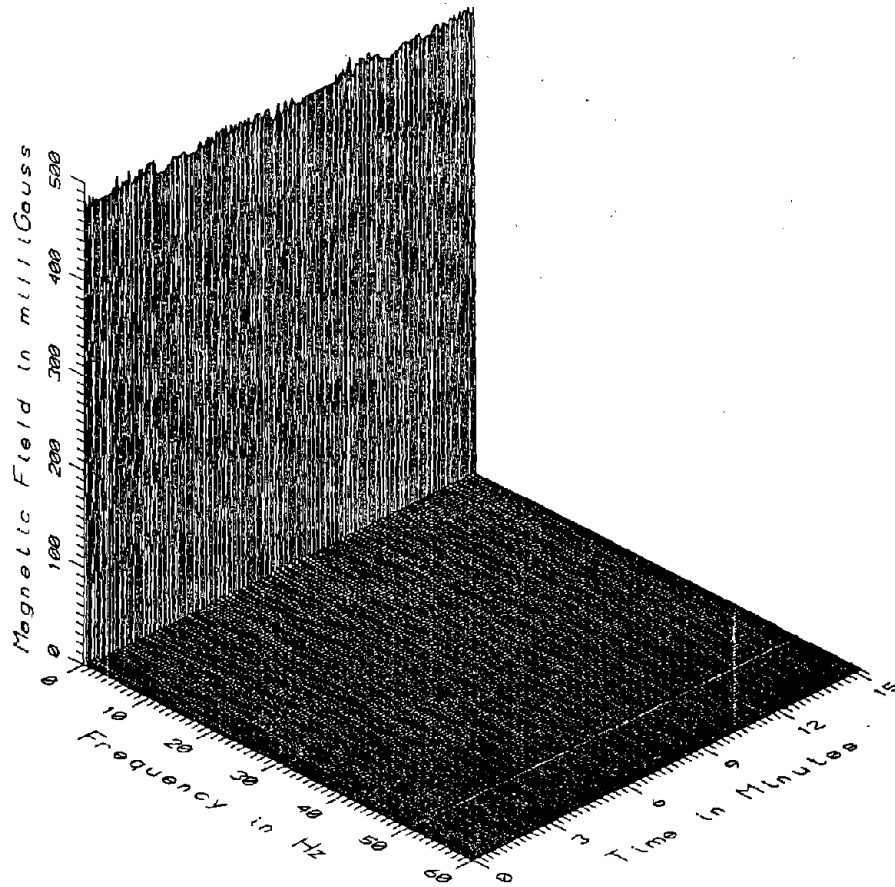

TR7022 - SOUTH EDGE OF OUTPUT TRANSFORMER YARD, 7M WEST OF PROFILE

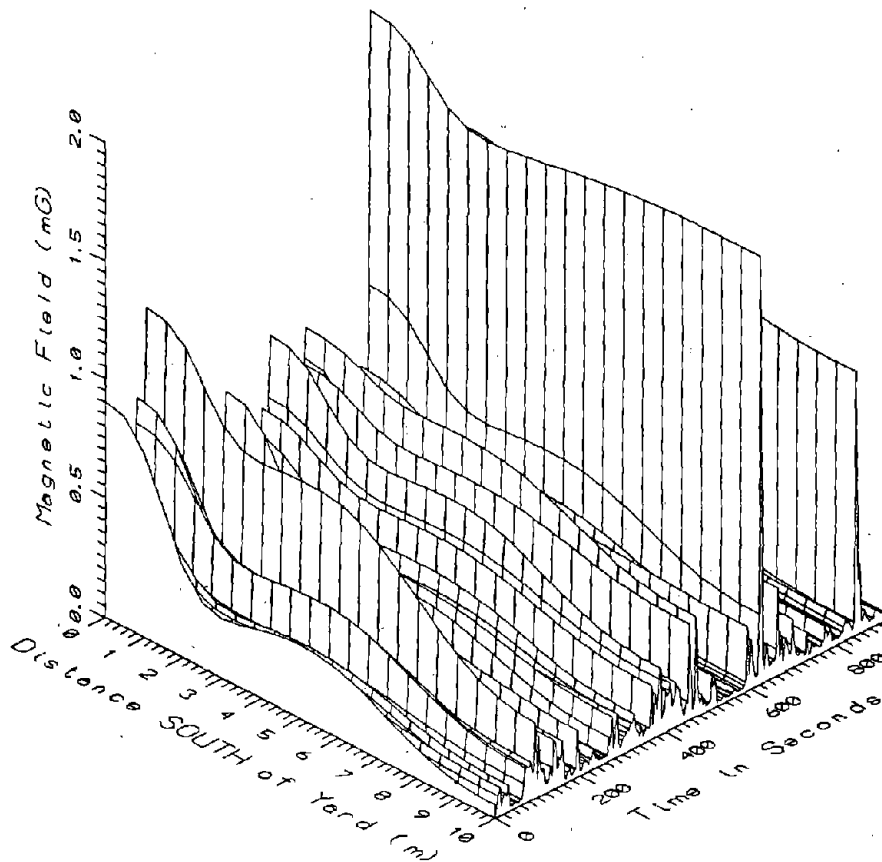

TR7022. OUTPUT TRANSFORMER YARD - LOW FREQUENCY, 5-45Hz

R-9

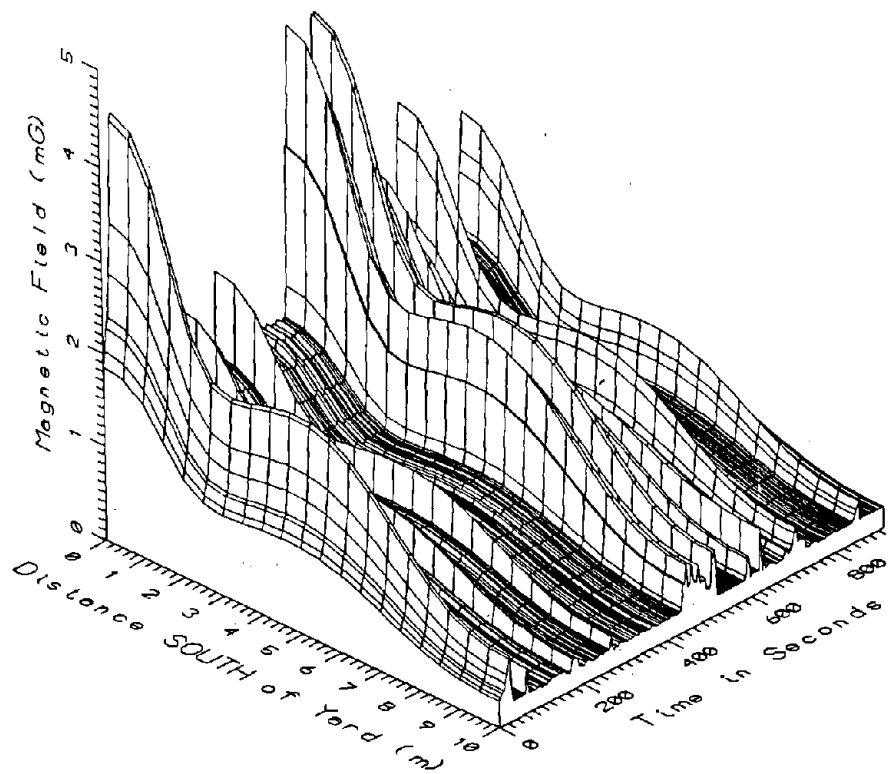

TR7022. OUTPUT TRANSFORMER YARD - POWER FREQUENCY, 50-60Hz

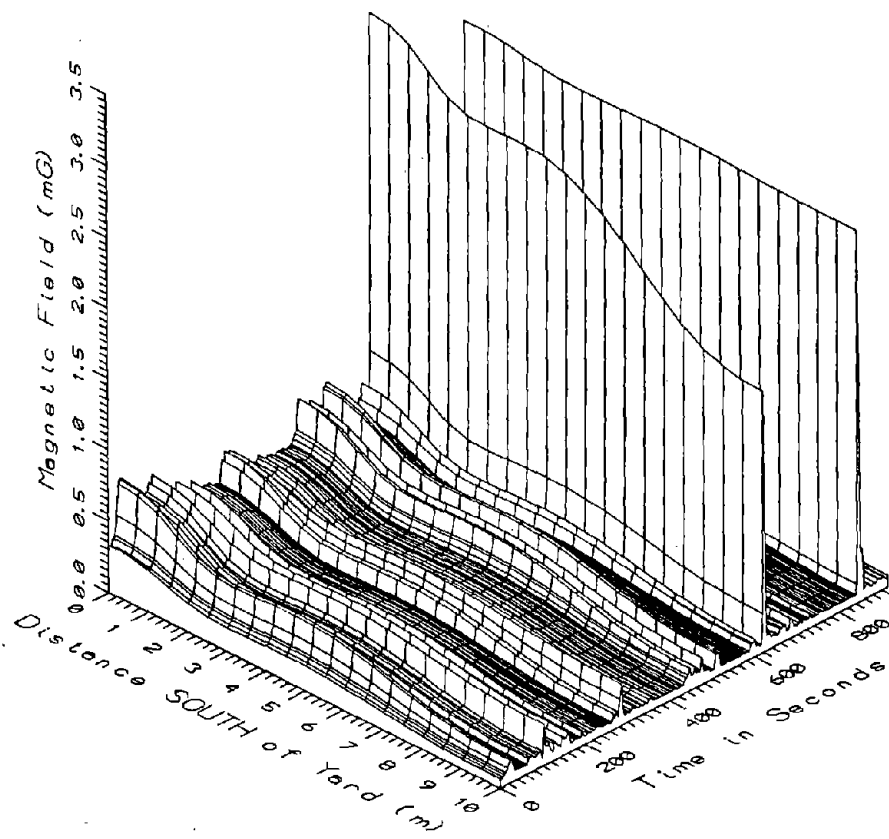

TR7022. OUTPUT TRANSFORMER YARD - POWER HARMONICS, 65-300Hz

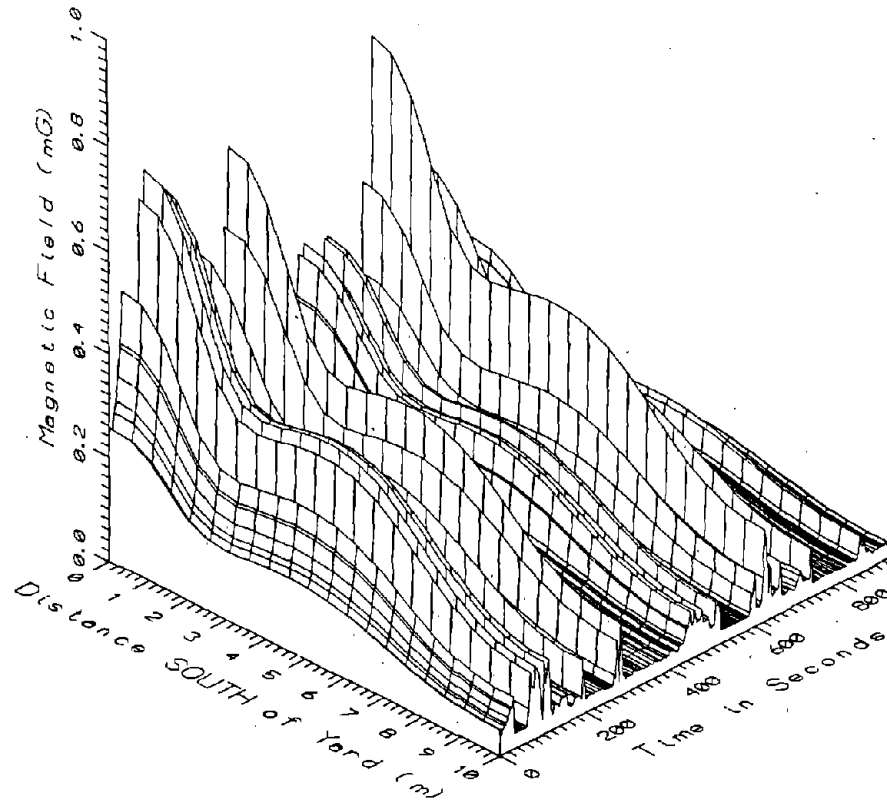

TR7022, OUTPUT TRANSFORMER YARD - HIGH FREQUENCY, 305-2560Hz

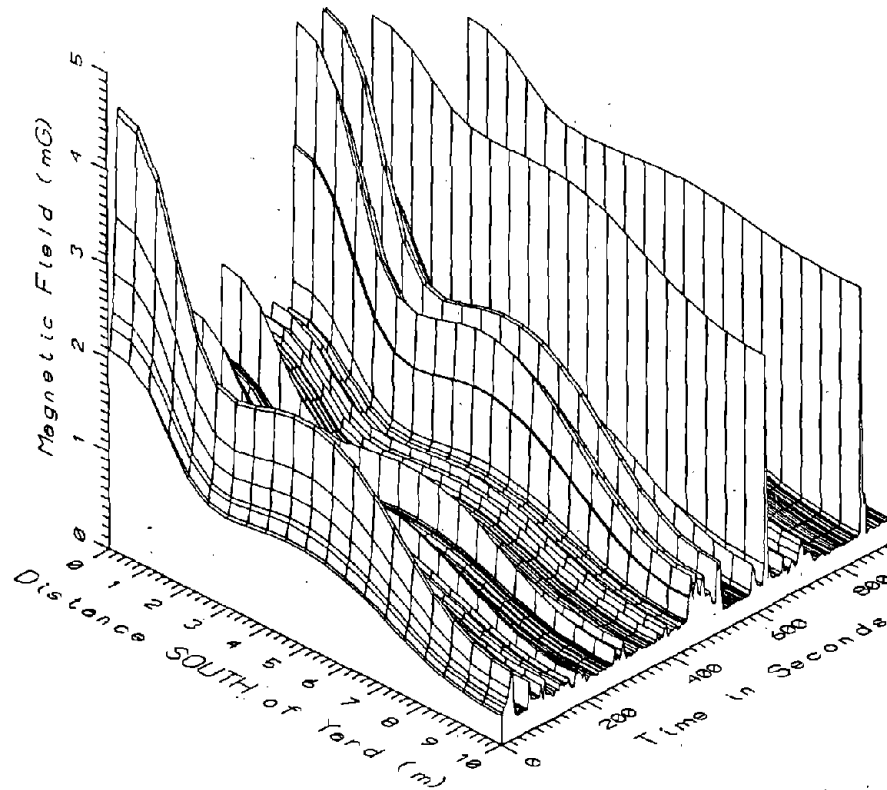

TR7022, OUTPUT TRANSFORMER YARD - ALL FREQUENCIES, 5-2560Hz

S-i

APPENDIX S

DATA SET TR7023

MEASUREMENTS NEAR THE BRAKING RESISTOR BANKS

APPENDIX 8

DATA SET TR7023
MEASUREMENTS NEAR THE BRAKING RESISTOR BANKS

Measurement Setup Code: 23
Vehicle Status: Running continuously
Measurement Date: August 9, 1990
Measurement Time: Start: 16:18:00
End: 16:38:00
Number of Samples: 255
Programmed Sample Interval: 4 sec
Actual Sample Interval: 4.7 sec

Frequency Spectrum Parameters

<u>Probe Type:</u>	<u>Coil (AC)</u>	<u>Fluxgate (DC)</u>
Maximum Frequency (Hz)	2560	256
Minimum Frequency (Hz)	5	0
Spectral Bandwidth (Hz)	5	0.5

Missing or Suspect Data: The fluxgate sensors 3 m and 10 m from the resistor bank yard were inoperative.

SETUP 23: BRAKING RESISTOR BANK

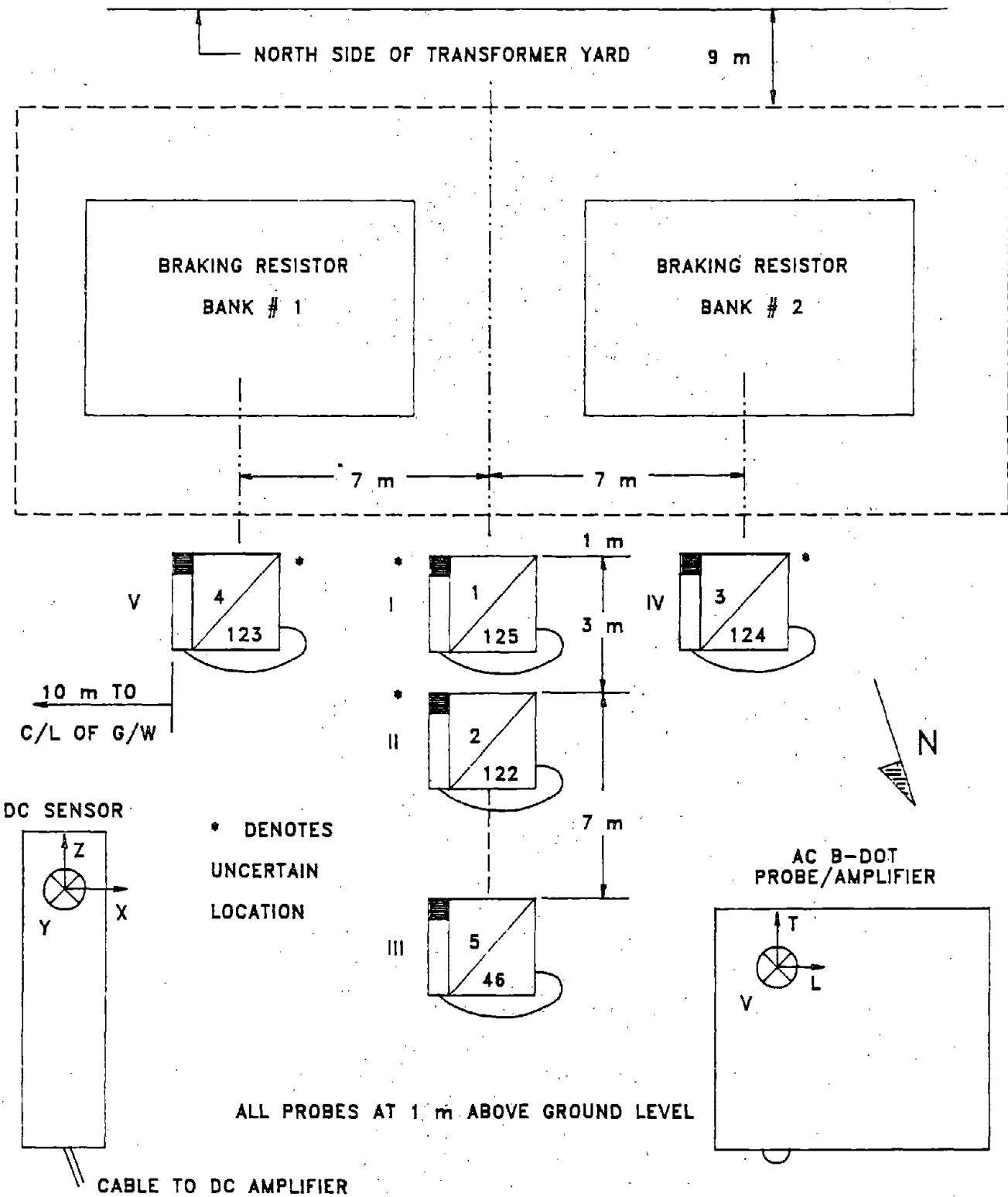

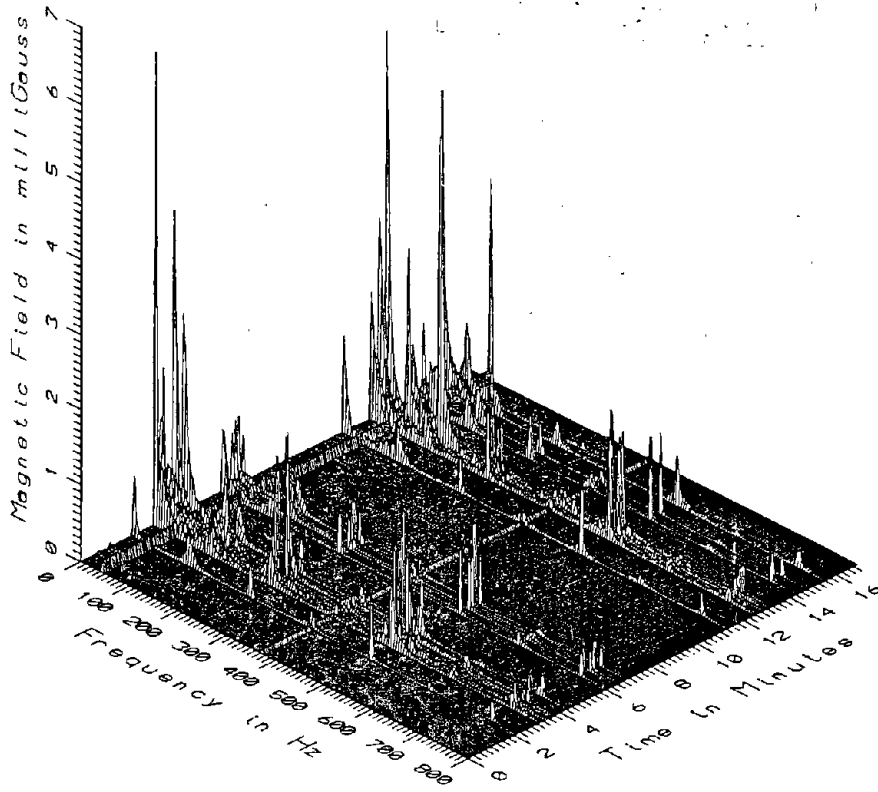

TR7023 - BRAKING RESISTOR BANK - NORTH YARD EDGE

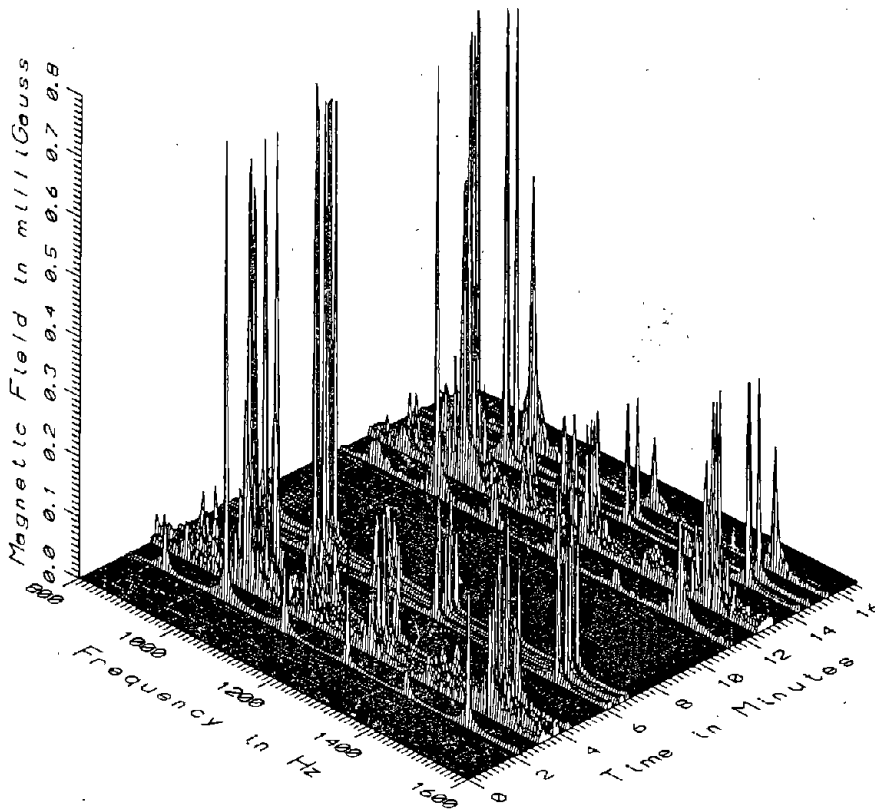

TR7023 - BRAKING RESISTOR BANK - NORTH YARD EDGE

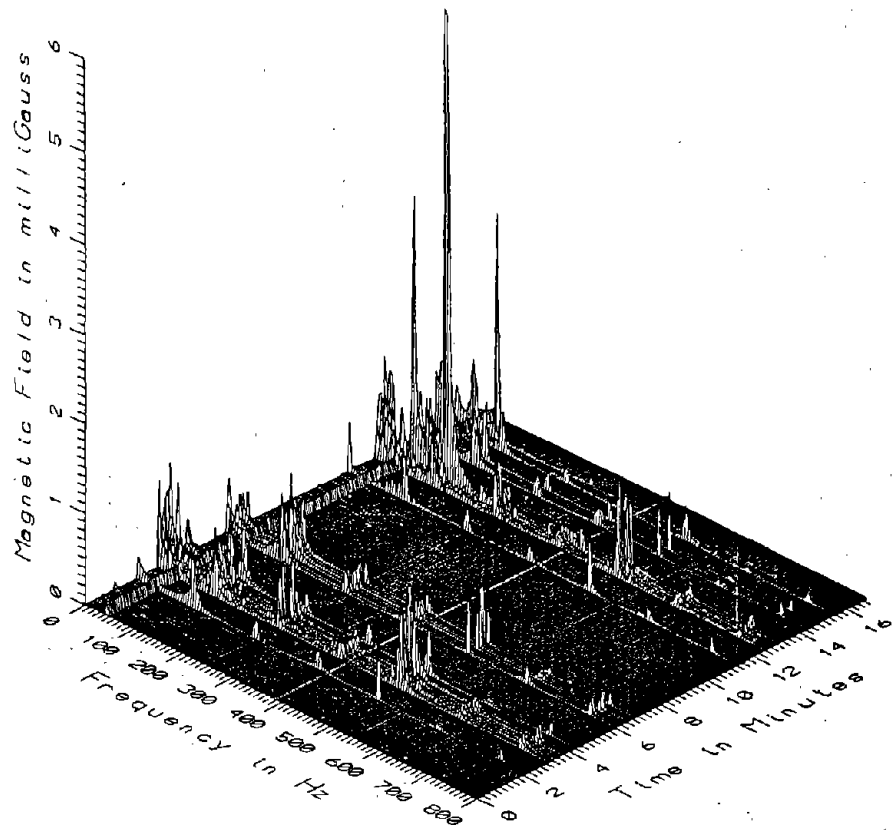

TR7023 - BRAKING RESISTOR BANK - 3M NORTH OF NORTH YARD EDGE

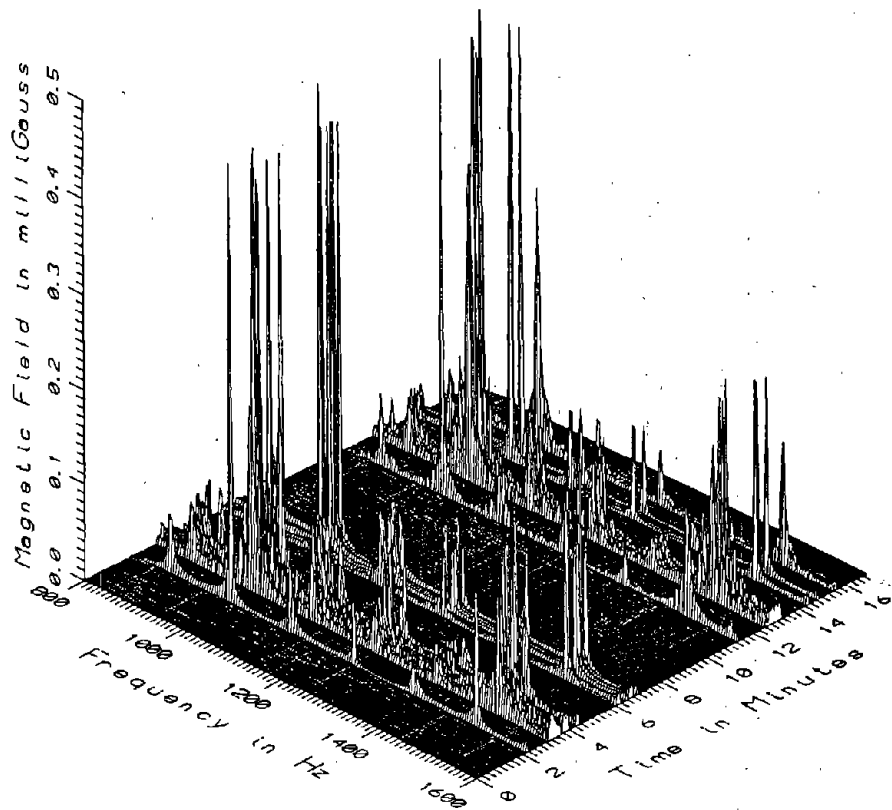

TR7023 - BRAKING RESISTOR BANK - 3M NORTH OF NORTH YARD EDGE

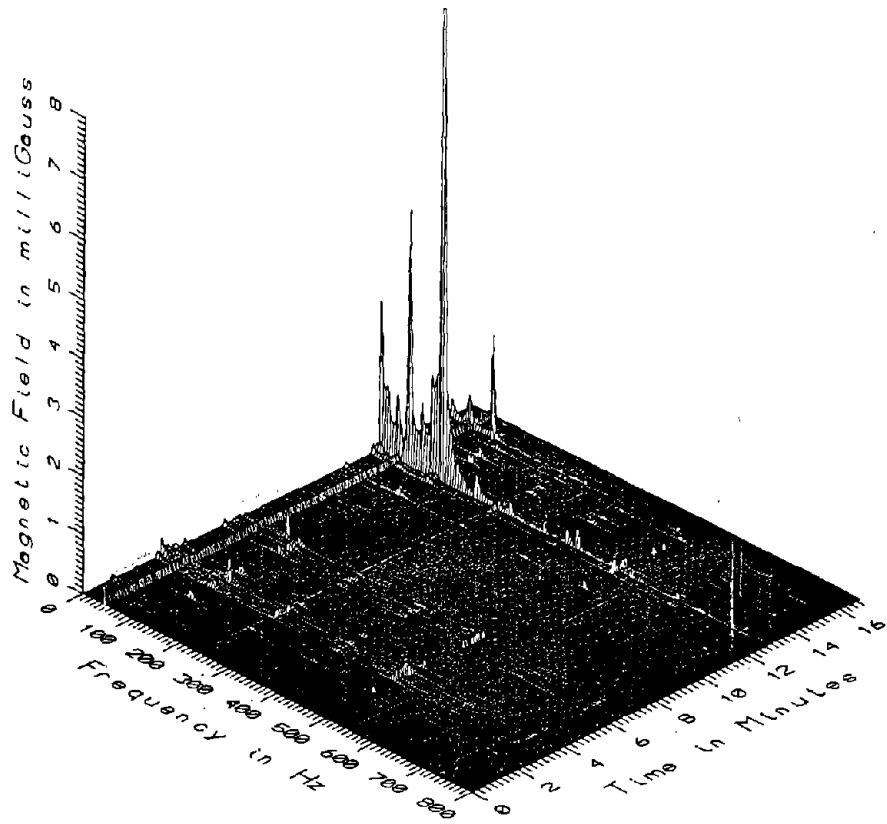

TR7023 - BRAKING RESISTOR BANK - 10M NORTH OF NORTH YARD EDGE

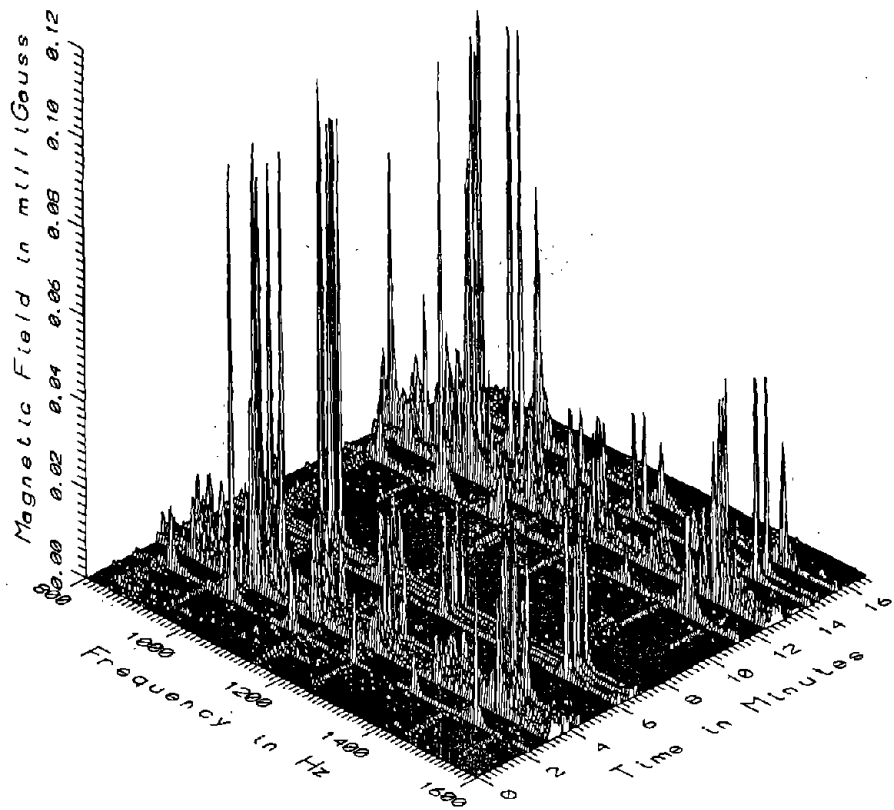

TR7023 - BRAKING RESISTOR BANK - 10M NORTH OF NORTH YARD EDGE

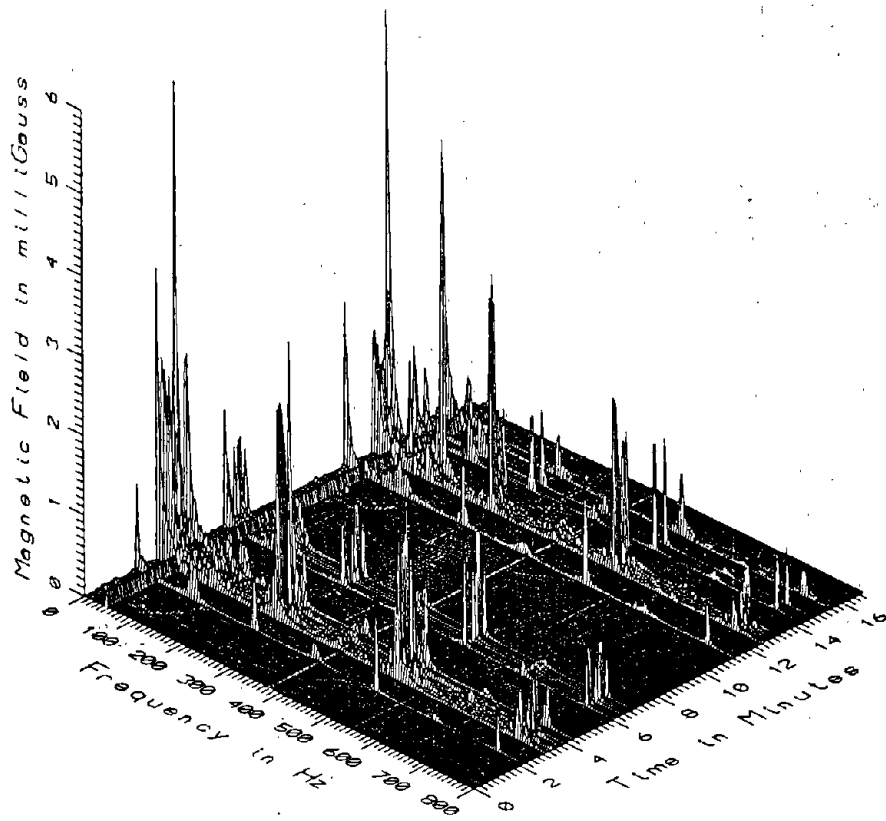

TR7023 - BRAKING RESISTOR BANK - NORTH YARD EDGE, 7M WEST OF PROFILE

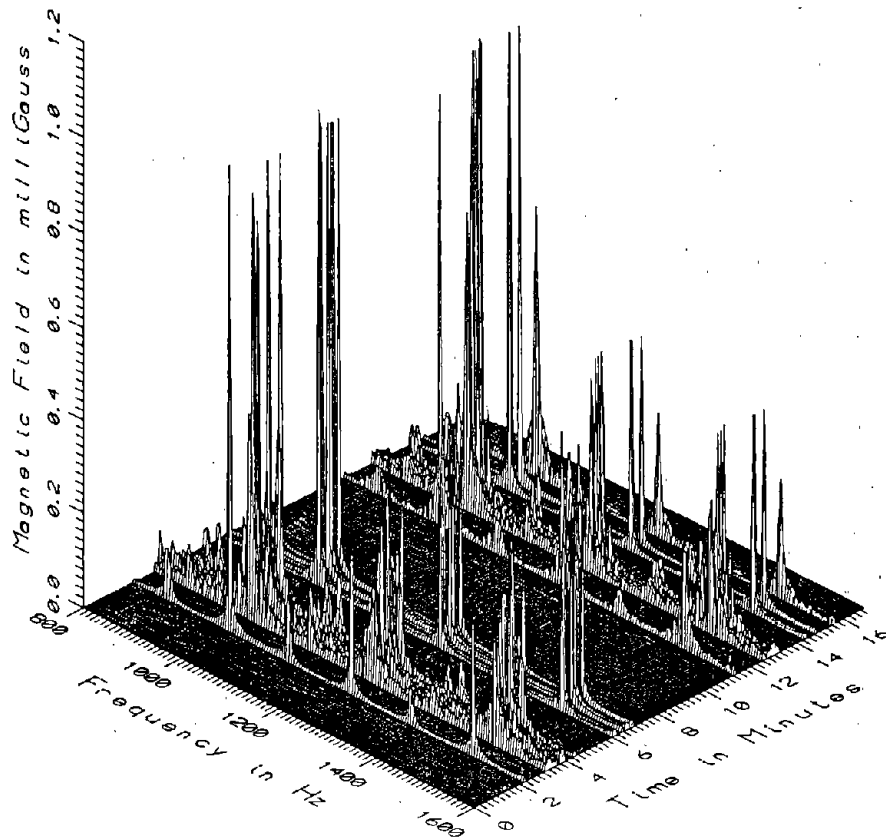

TR7023 - BRAKING RESISTOR BANK - NORTH YARD EDGE, 7M WEST OF PROFILE

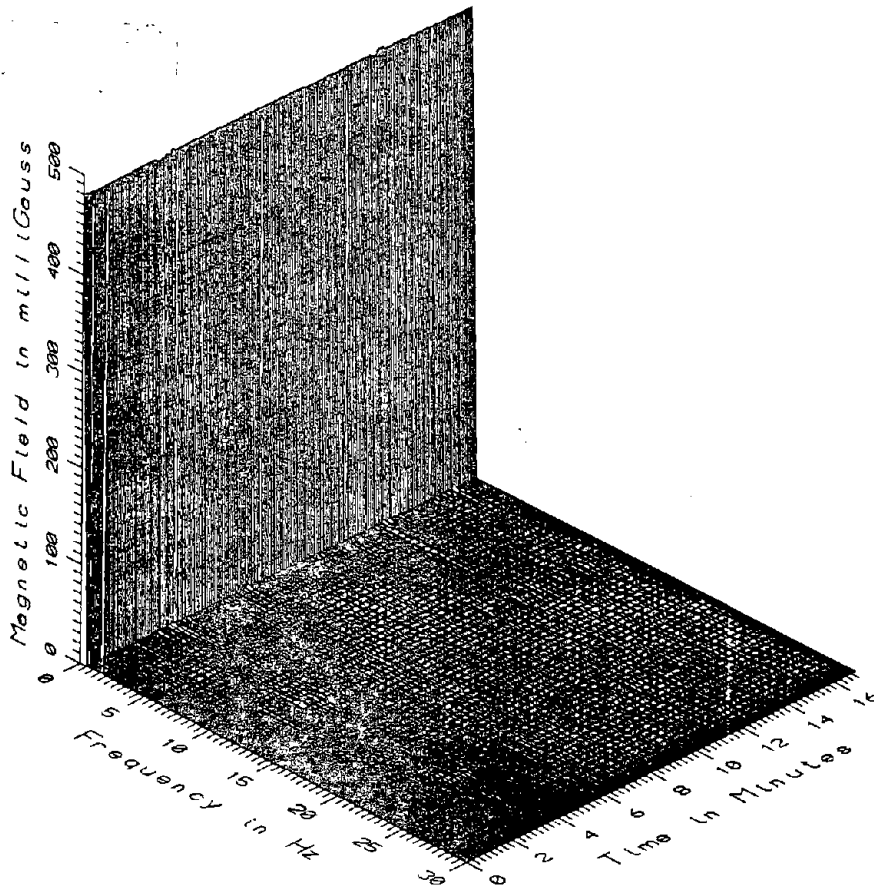

TR7023 - BRAKING RESISTOR BANK - NORTH YARD EDGE

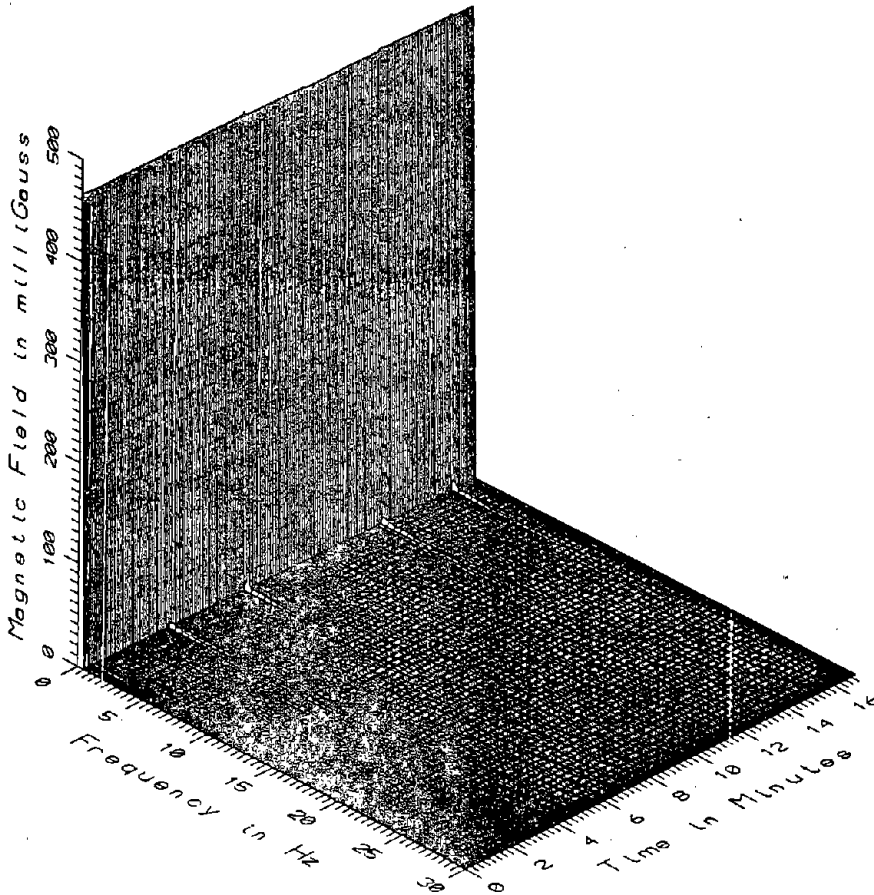

TR7023 - BRAKING RESISTOR BANK - NORTH YARD EDGE, 7M EAST OF PROFILE

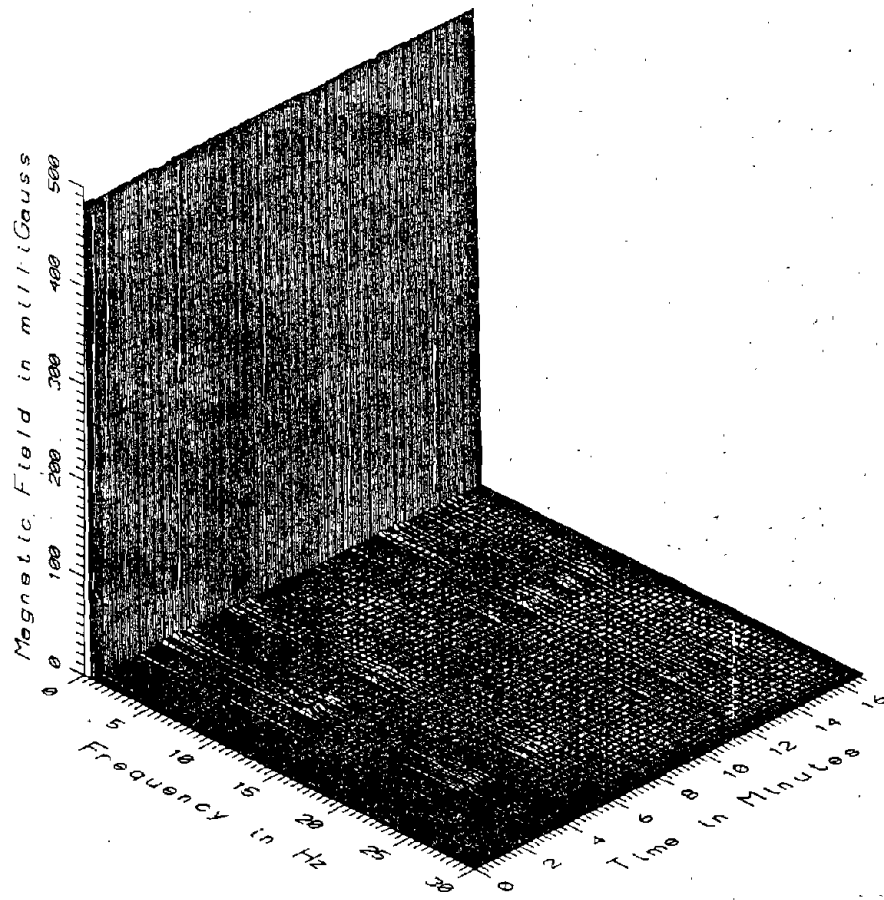

TR7023 - BRAKING RESISTOR BANK - NORTH YARD EDGE, 7M WEST OF PROFILE

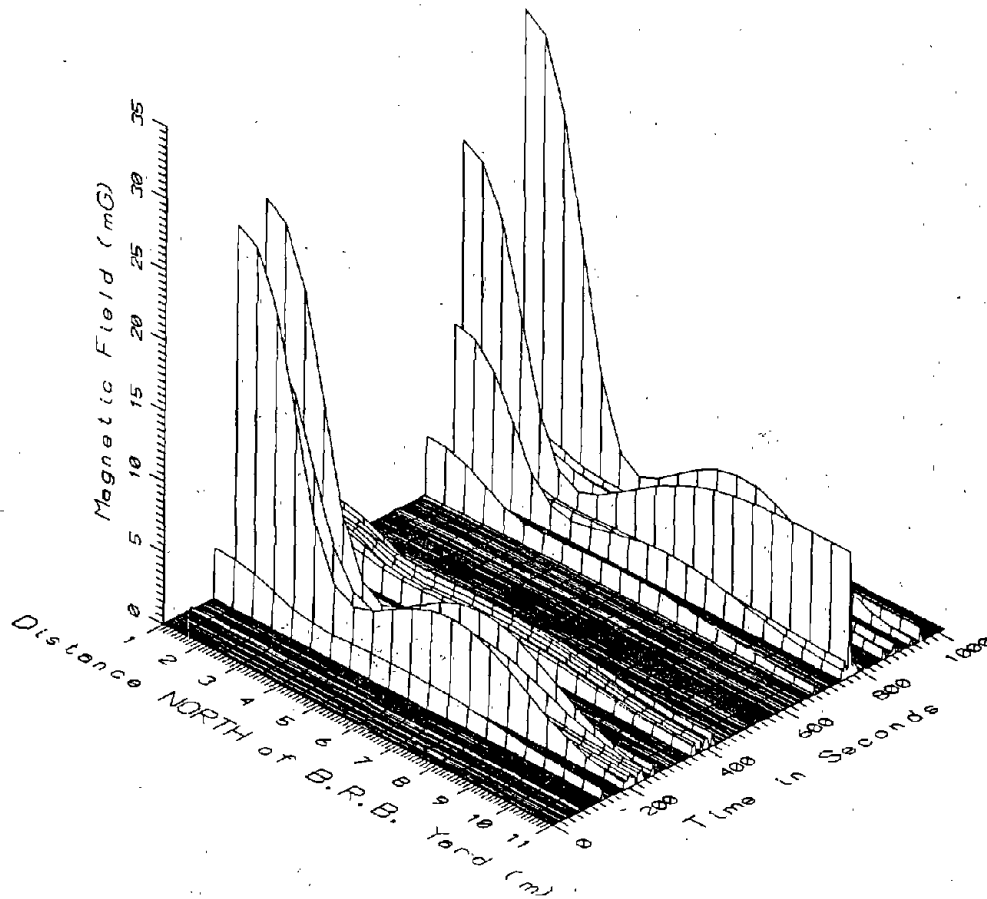

TR7023 - BRAKING RESISTOR BANK - LOW FREQUENCY, 5-45Hz

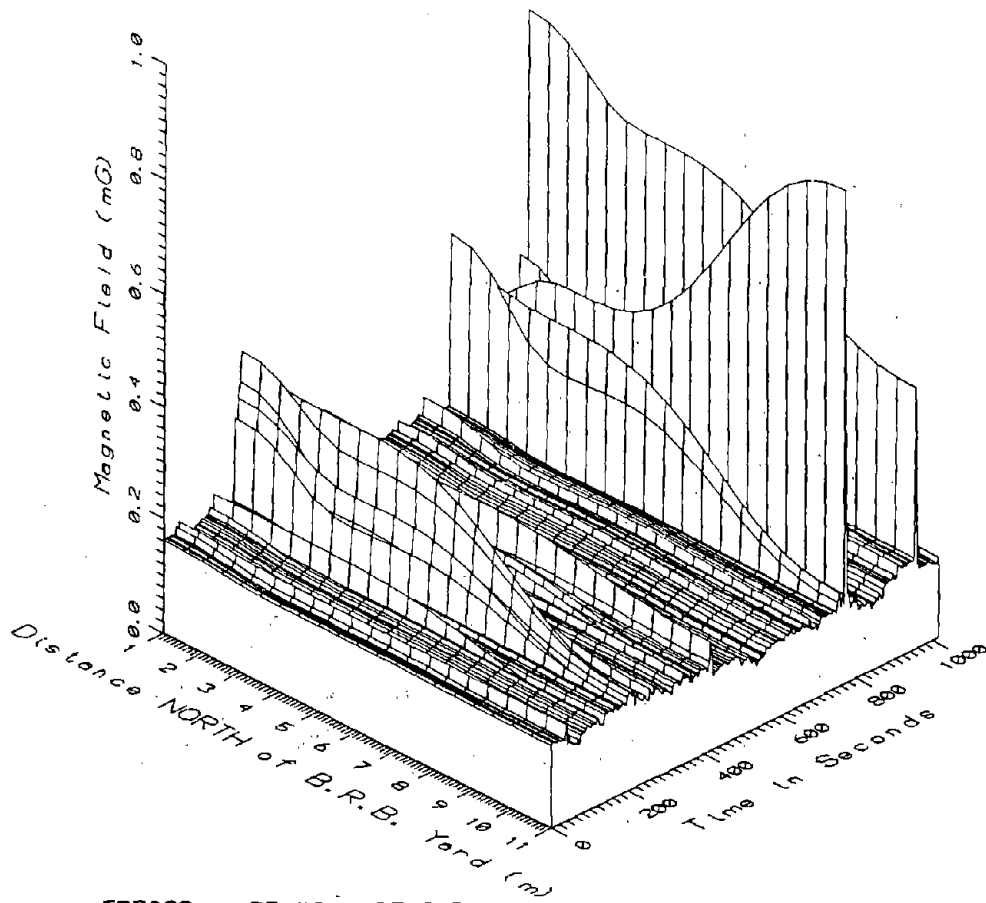

TR7023 - BRAKING RESISTOR BANK - POWER FREQUENCY, 50-60Hz

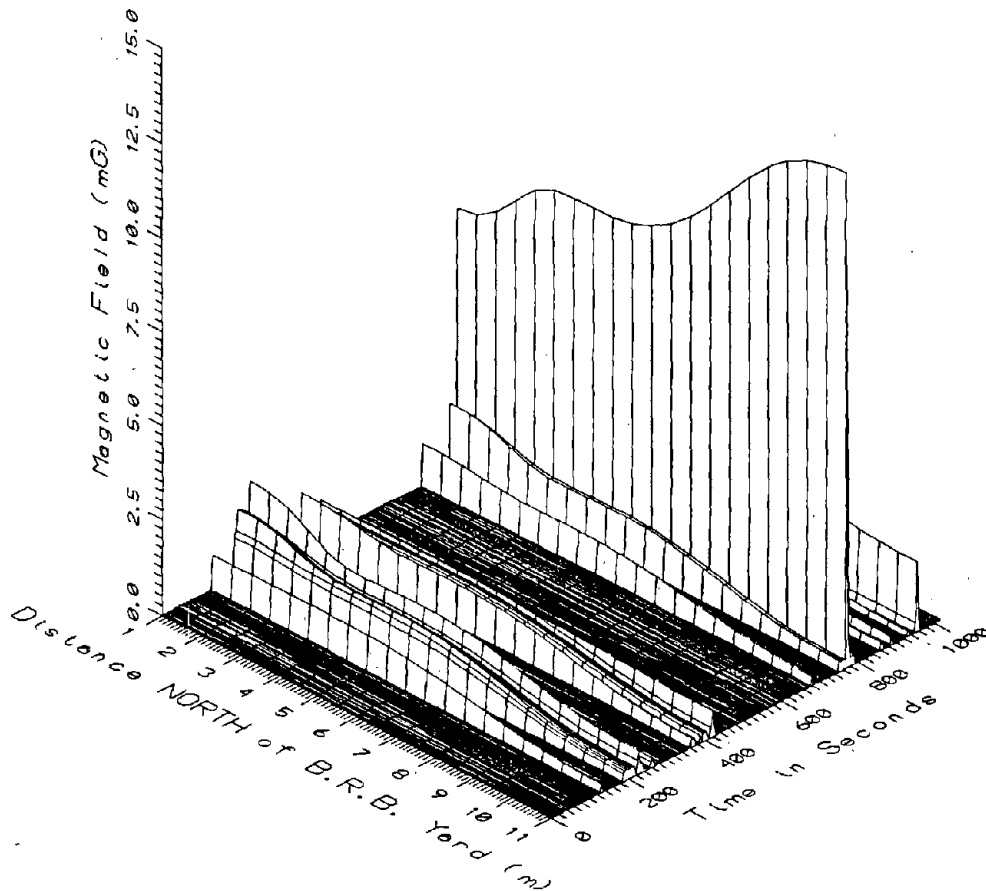

TR7023 - BRAKING RESISTOR BANK - POWER HARMONICS, 65-300Hz

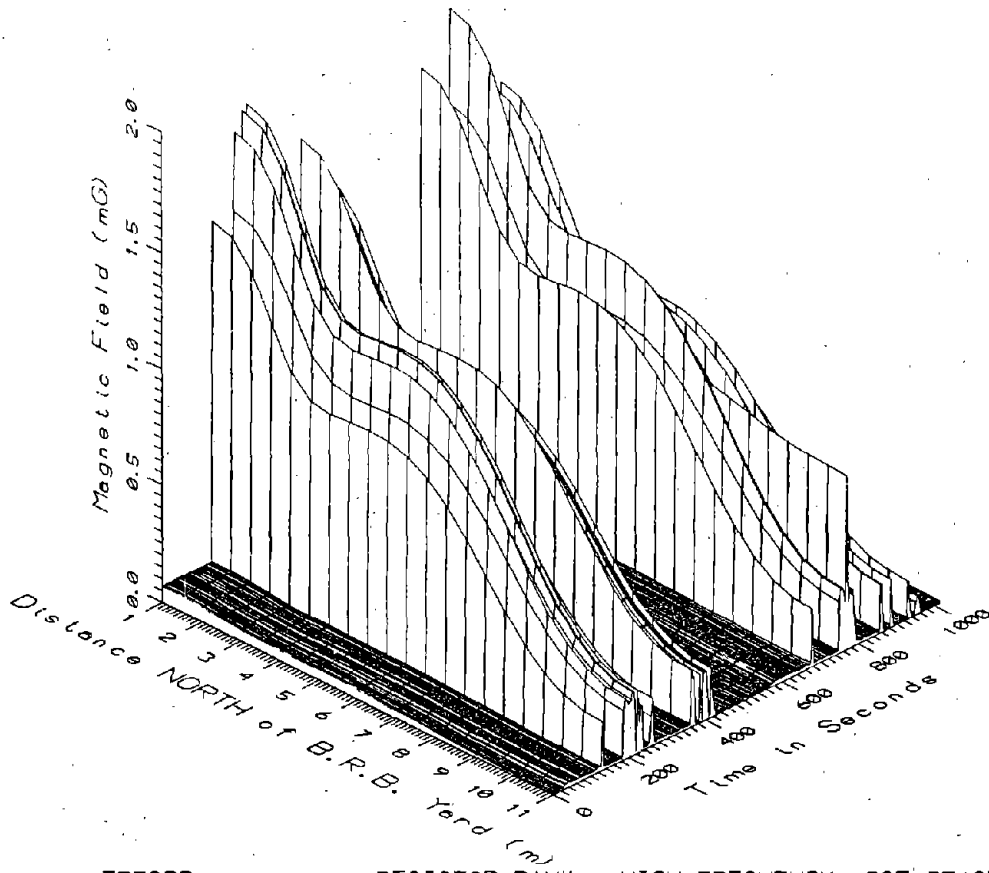

TR7023 - BRAKING RESISTOR BANK - HIGH FREQUENCY, 305-2560Hz

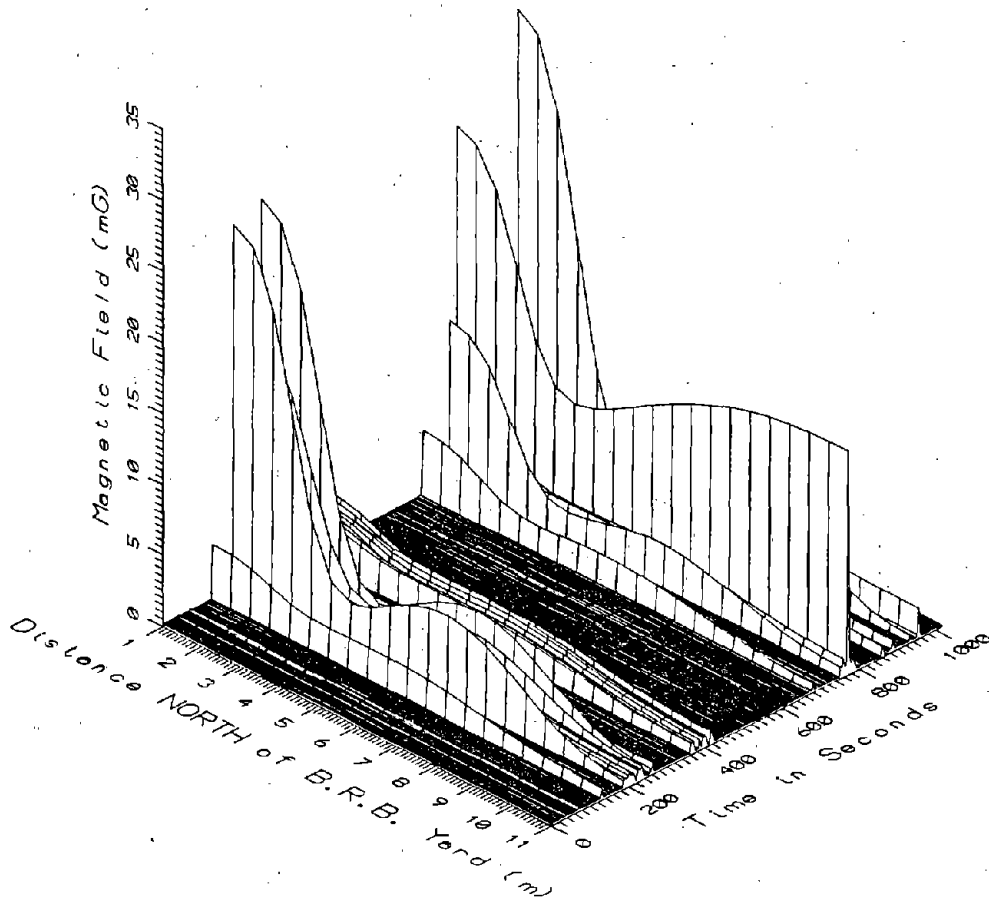

TR7023 - BRAKING RESISTOR BANK - ALL FREQUENCIES, 5-2560Hz

T-1

APPENDIX T

DATA SET TR7024

MEASUREMENTS NEAR THE BRAKING RESISTOR BANKS

APPENDIX T

DATA SET TR7024
MEASUREMENTS NEAR THE BRAKING RESISTOR BANKS

Measurement Setup Code: 23
Vehicle Status: Running continuously
Measurement Date: August 9, 1990
Measurement Time: Start: 16:49:10
End: 16:55:30
Number of Samples: 68
Programmed Sample Interval: 4 sec
Actual Sample Interval: 5.8 sec

Frequency Spectrum Parameters

<u>Probe Type:</u>	<u>Coil (AC)</u>	<u>Fluxgate (DC)</u>
Maximum Frequency (Hz)	2560	256
Minimum Frequency (Hz)	5	0
Spectral Bandwidth (Hz)	5	0.5

Missing or Suspect Data: The fluxgate sensors 3 m and 10 m from the resistor bank yard were inoperative.

SETUP 23: BRAKING RESISTOR BANK

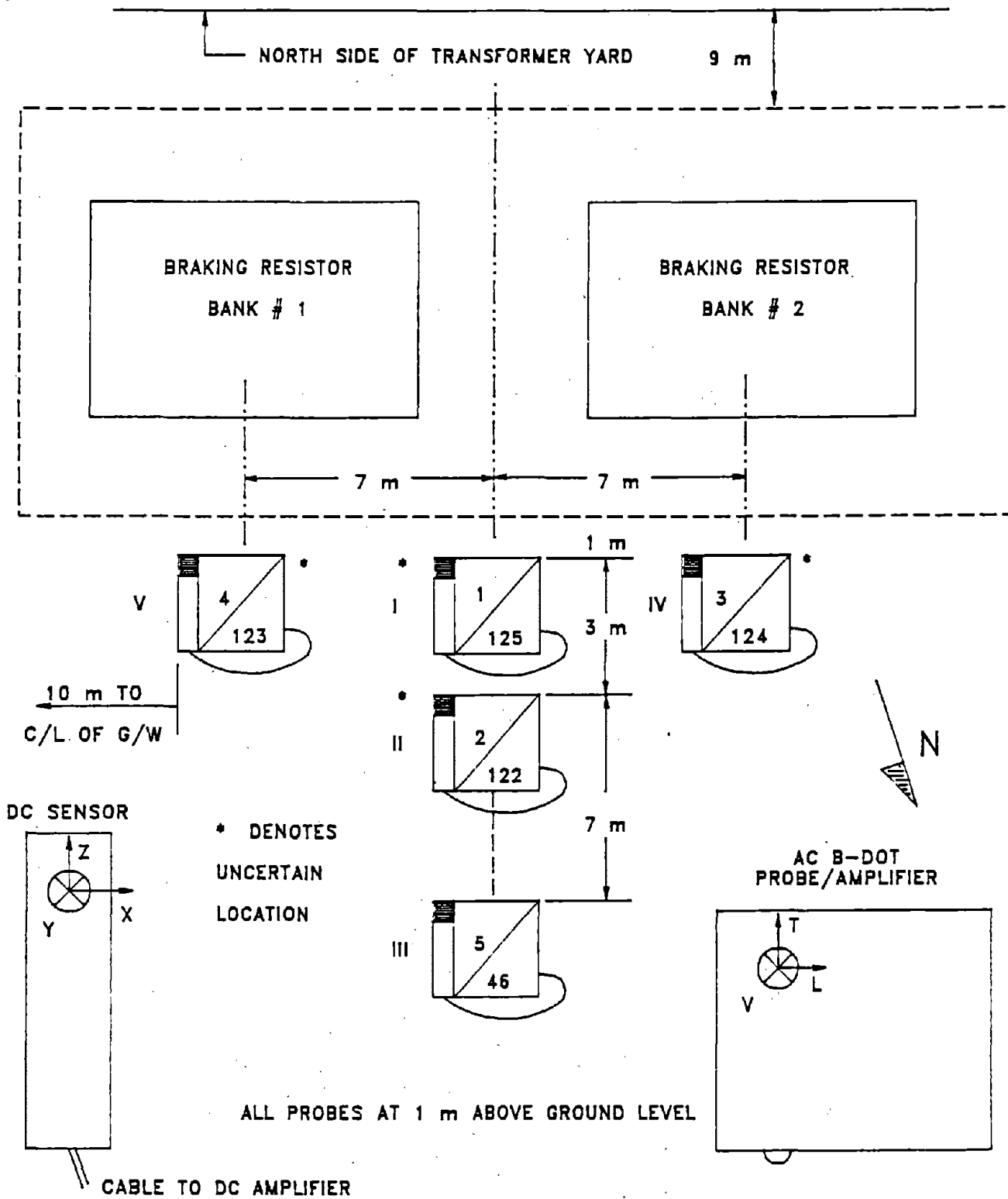

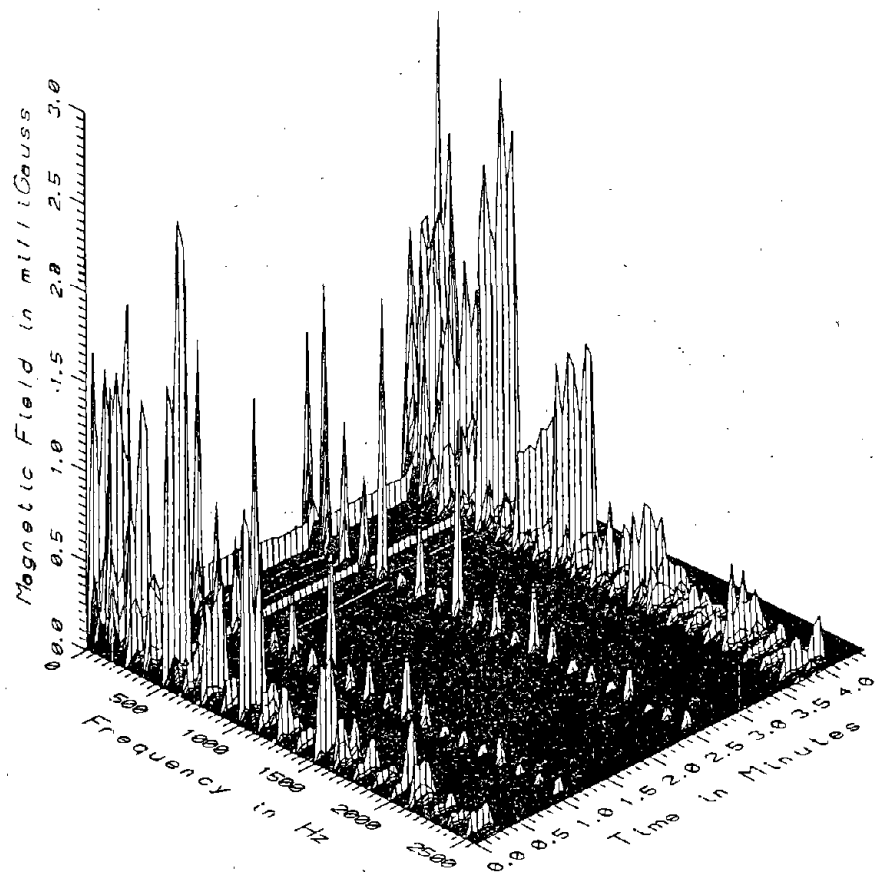

TR7024 - BRAKING RESISTOR BANK, NORTH YARD EDGE

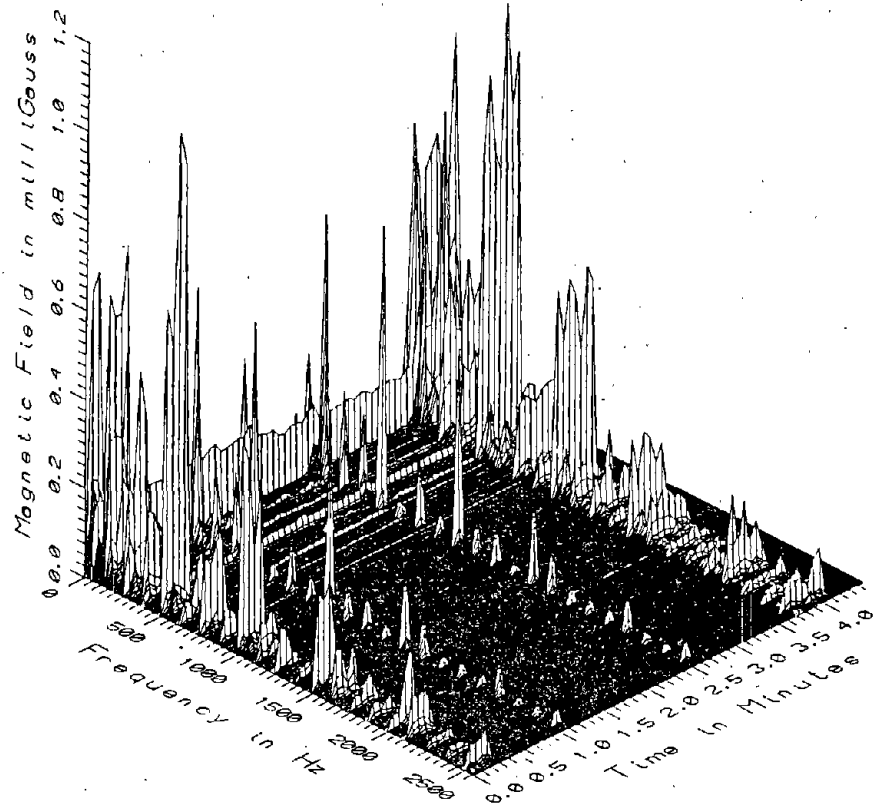

TR7024 - BRAKING RESISTOR BANK, 3M NORTH OF NORTH YARD EDGE

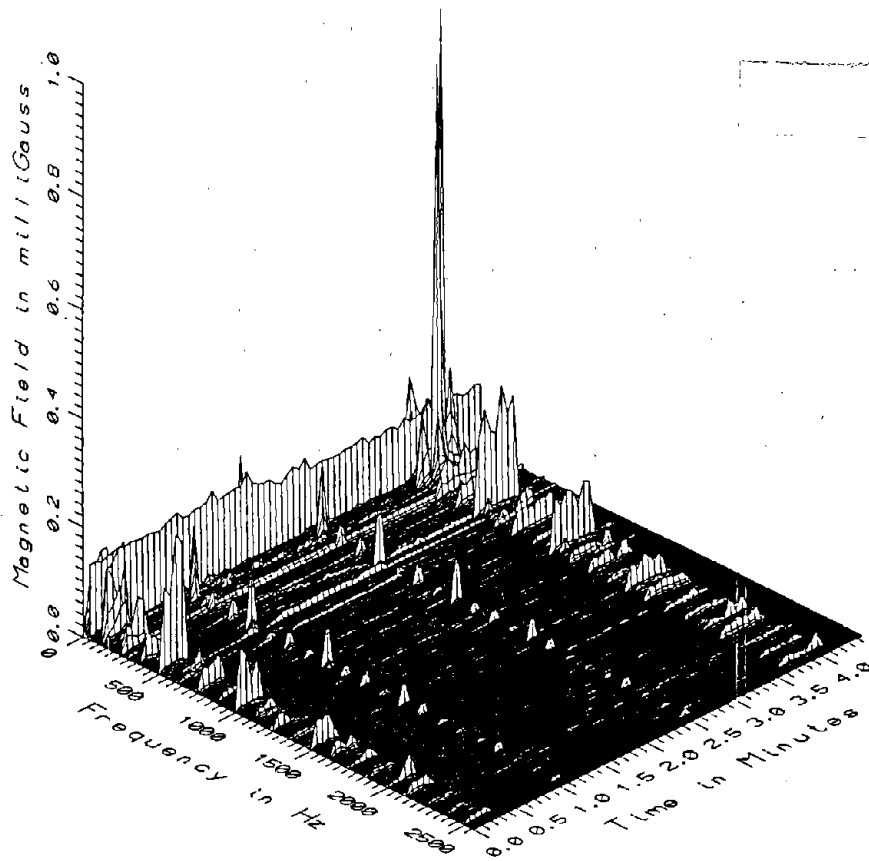

TR7024 - BRAKING RESISTOR BANK, 10M NORTH OF NORTH YARD EDGE

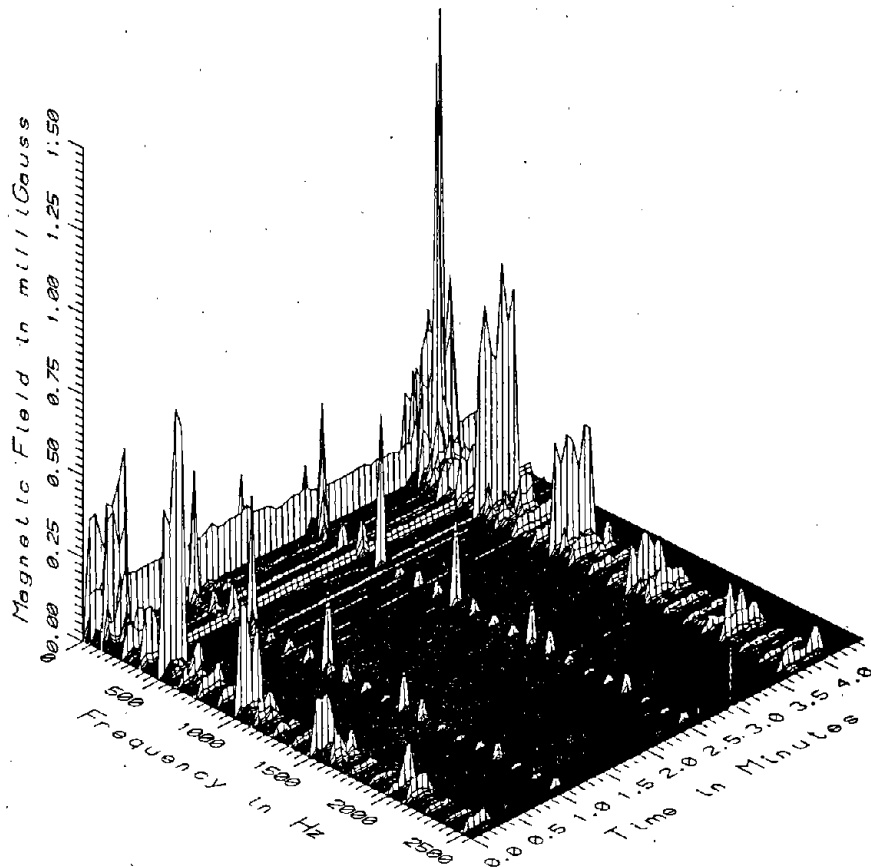

TR7024 - BRAKING RESISTOR BANK, NORTH YARD EDGE, 7M EAST OF PROFILE

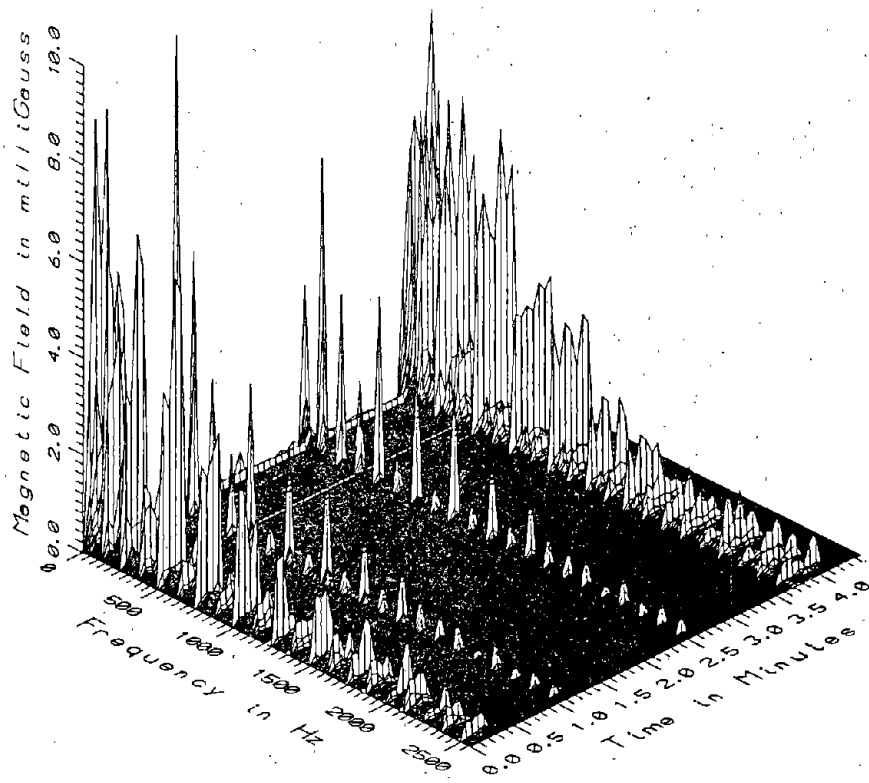

TR7024 - BRAKING RESISTOR BANK, NORTH YARD EDGE, 7M WEST OF PROFILE

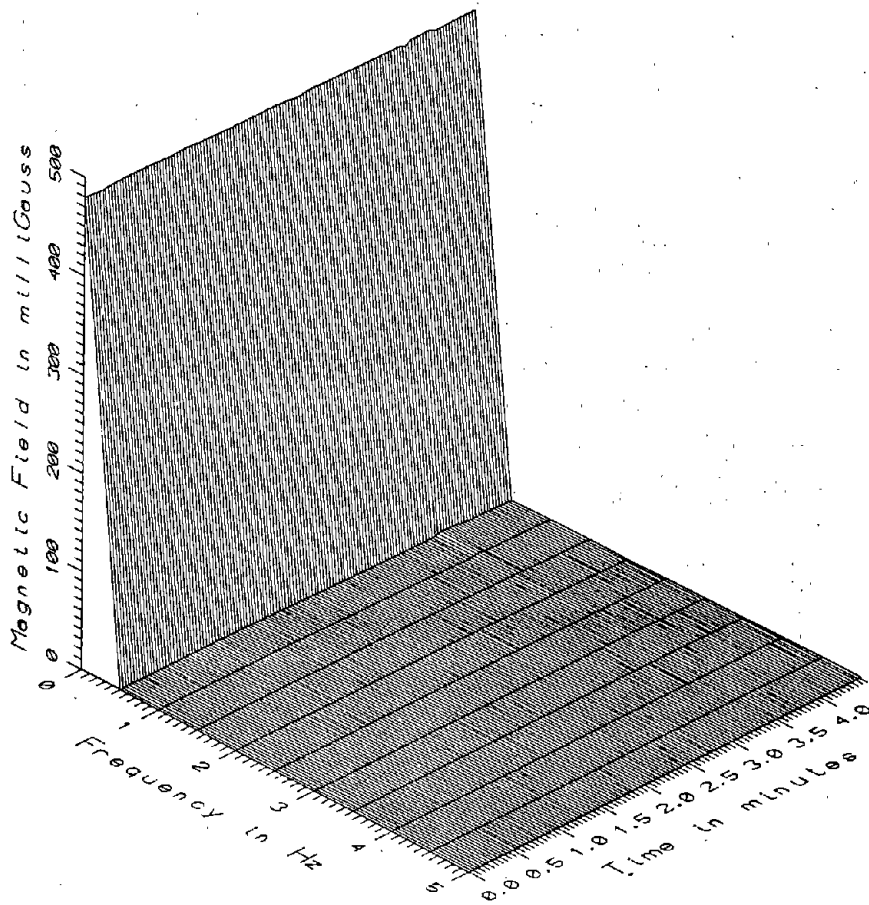

TR7024 - BRAKING RESISTOR BANK - NORTH YARD EDGE

T-5

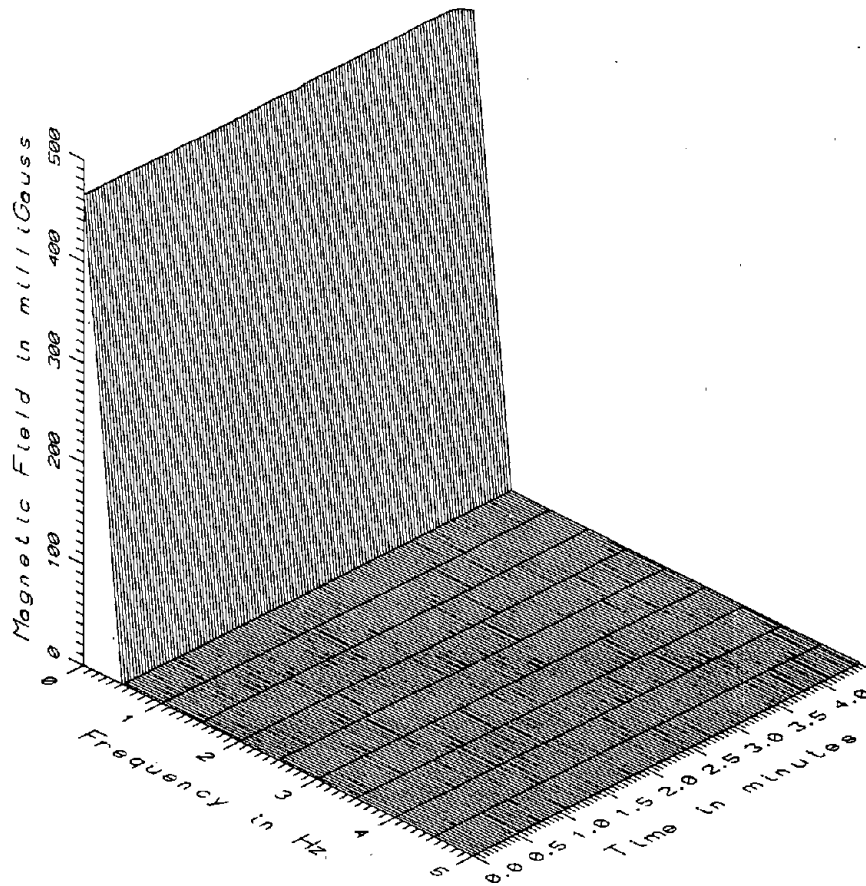

TR7024 - BRAKING RESISTOR BANK - NORTH YARD EDGE, 7M EAST OF PROFILE

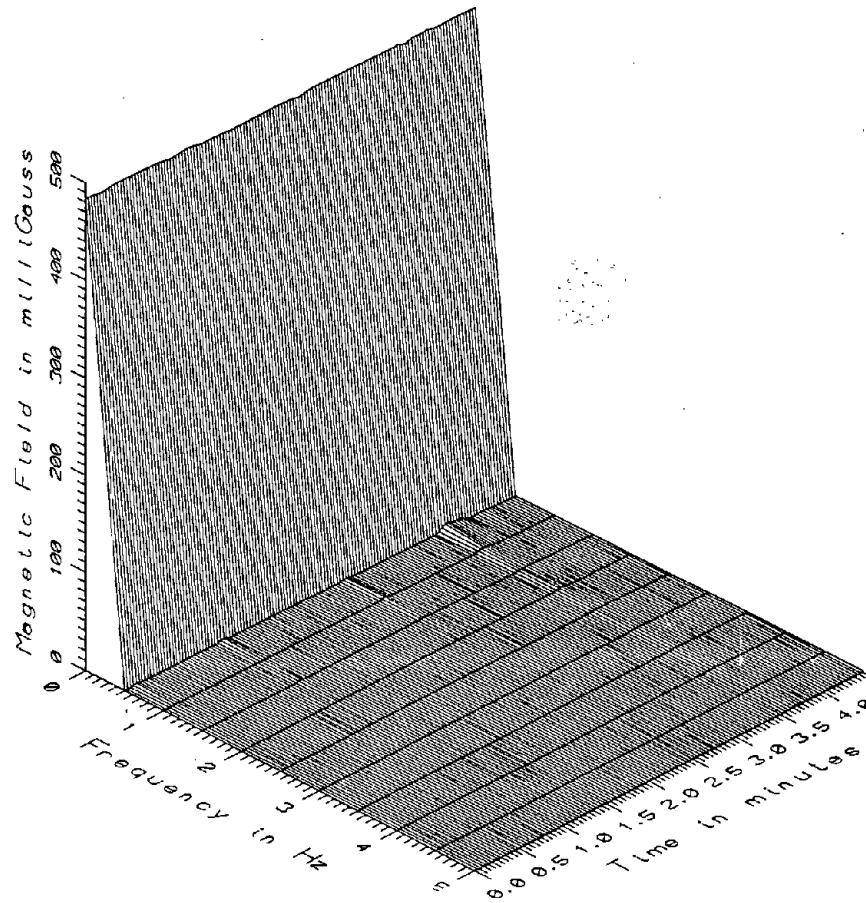

TR7024 - BRAKING RESISTOR BANK - NORTH YARD EDGE, 7M WEST OF PROFILE

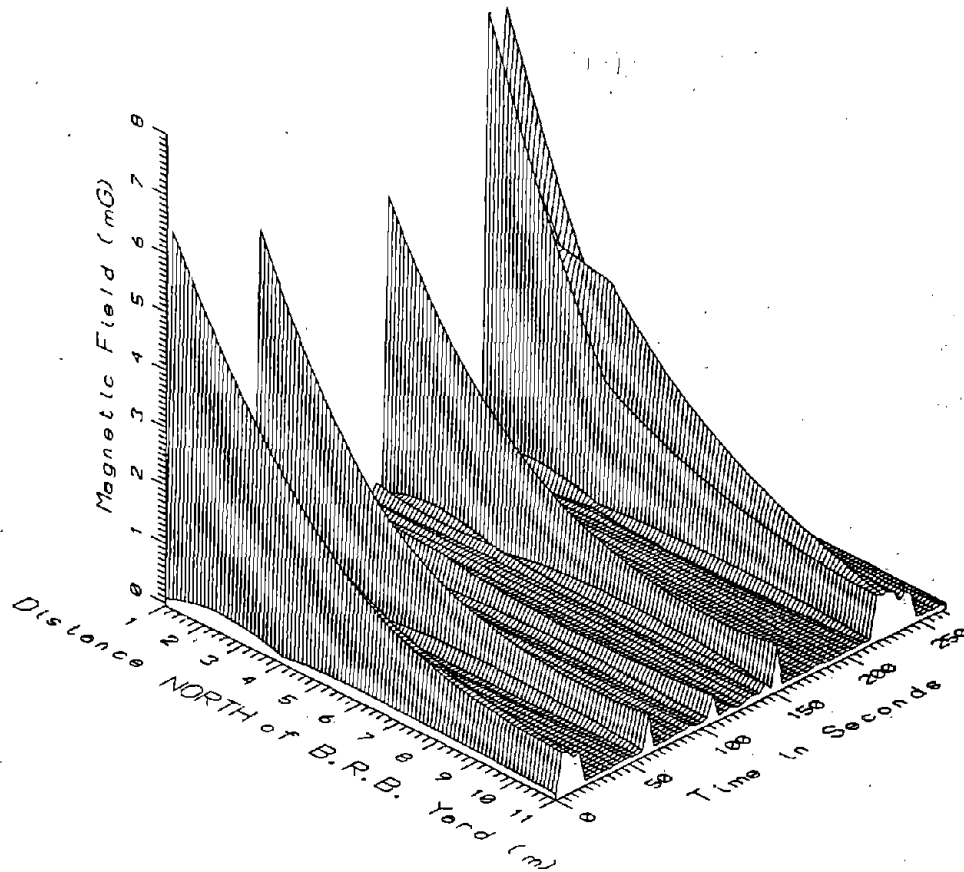

TR7024. BRAKING RESISTOR BANK - LOW FREQUENCY, 5-45Hz

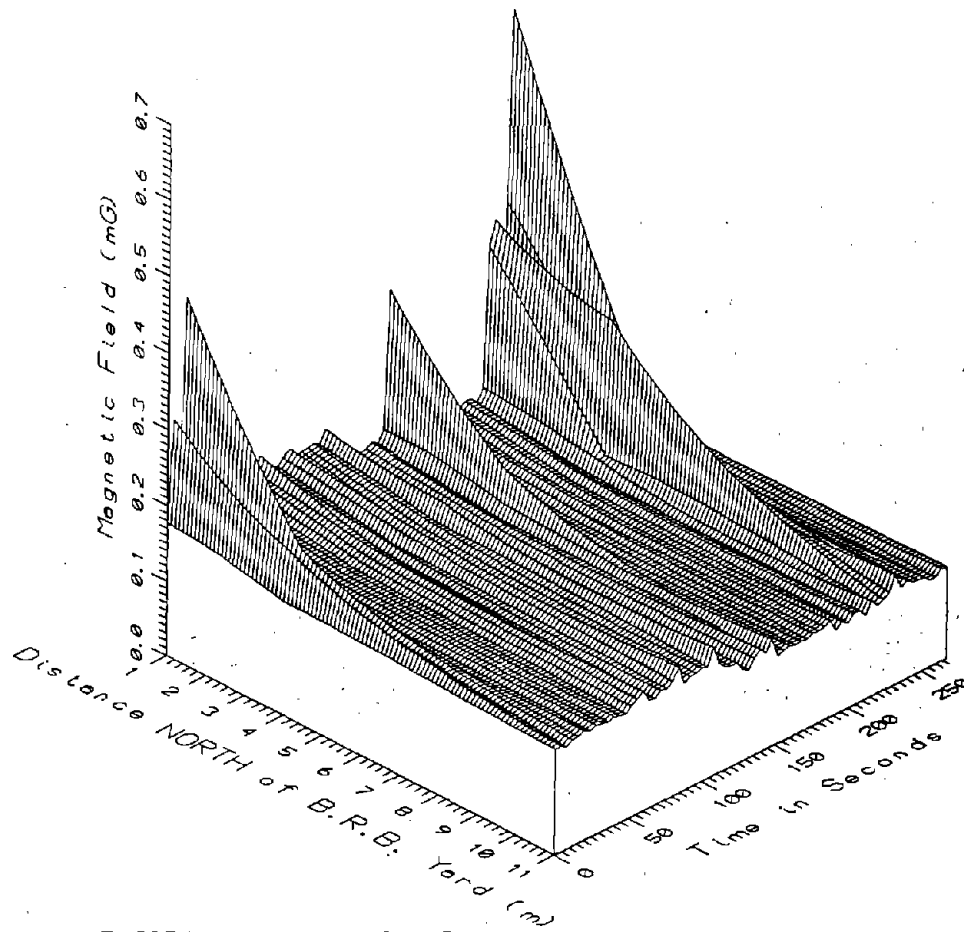

TR7024. BRAKING RESISTOR BANK - POWER FREQUENCY, 50-60Hz

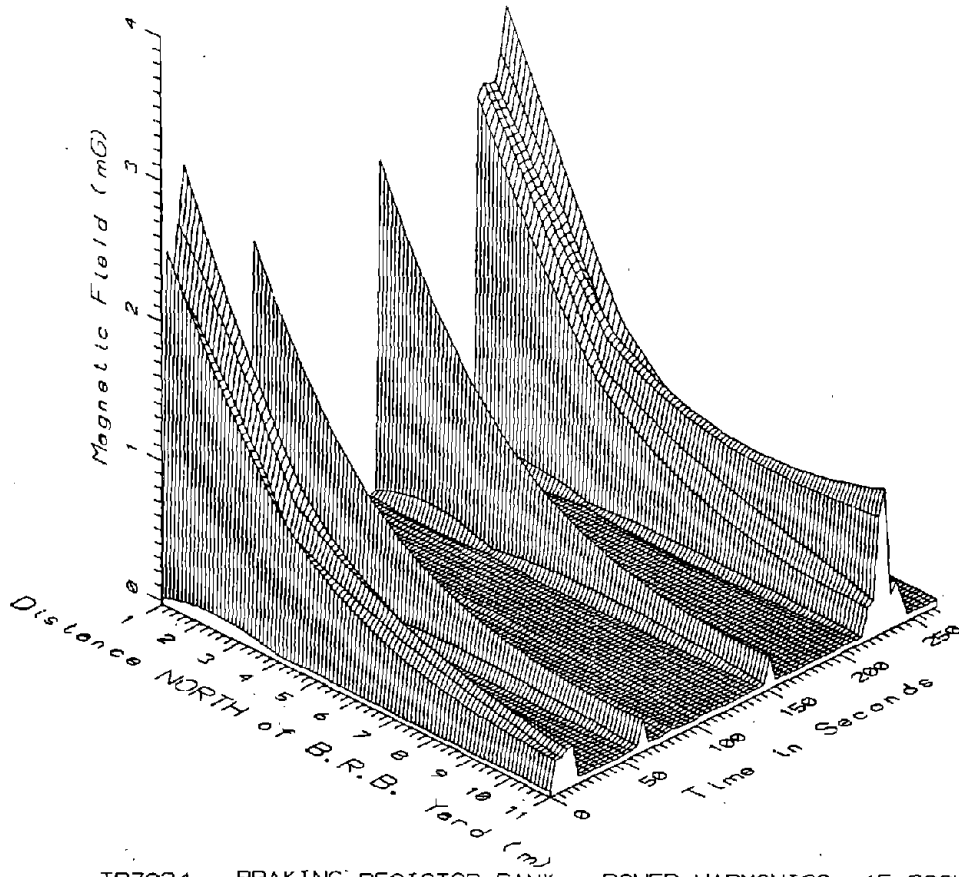

TR7024. BRAKING RESISTOR BANK - POWER HARMONICS, 65-300Hz

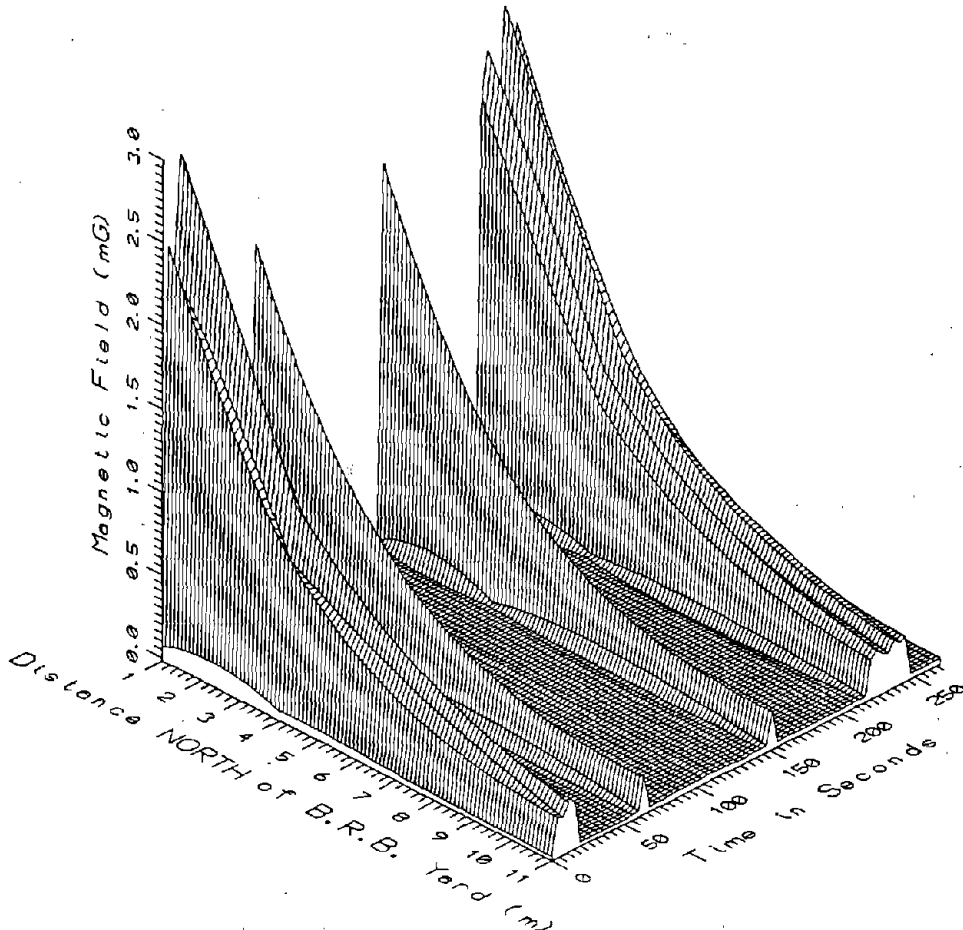

TR7024. BRAKING RESISTOR BANK - HIGH FREQUENCY, 305-2560Hz

T-9

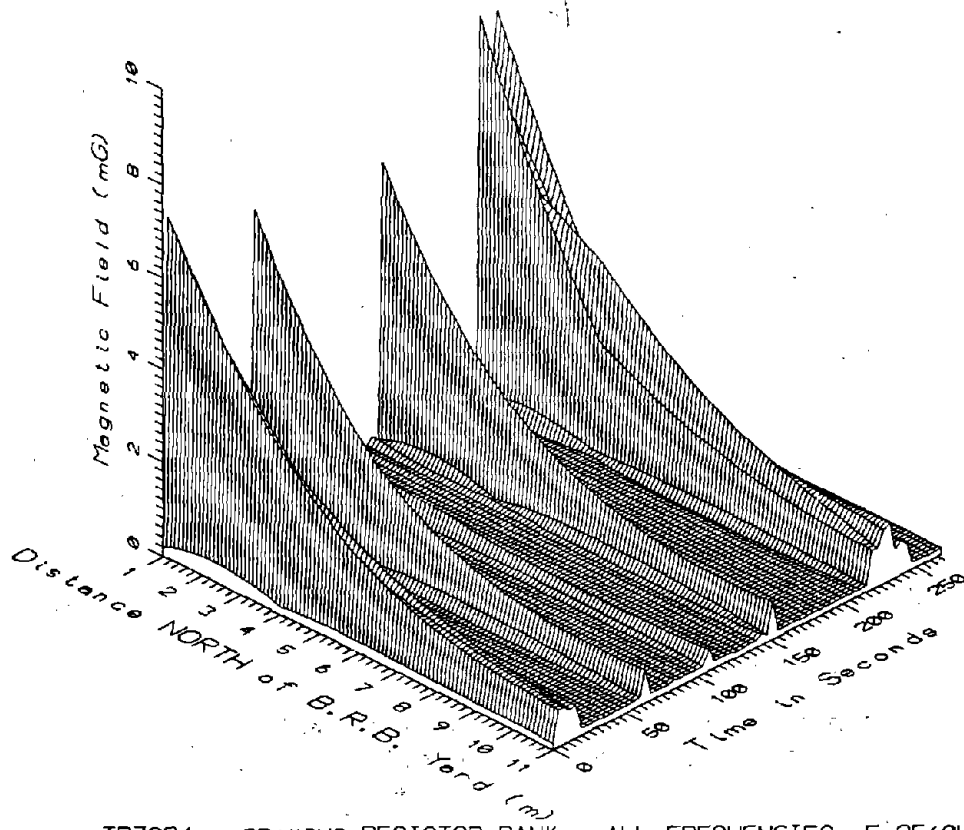

TR7024, BRAKING RESISTOR BANK - ALL FREQUENCIES, 5-2560Hz

U-i

APPENDIX U

DATA SET TR7025

**LATERAL PROFILE
BENEATH THE LOW CONCRETE GUIDEWAY
WITH THE VEHICLE PARKED**

APPENDIX U

DATA SET TR7025
LATERAL PROFILE BENEATH THE LOW CONCRETE GUIDEWAY
WITH THE VEHICLE PARKED

Measurement Setup Code: 24
Vehicle Status: Parked overhead
Measurement Date: August 9, 1990
Measurement Time: Start: 17:31:00
End: 17:32:44
Number of Samples: 10
Programmed Sample Interval: 4 sec
Actual Sample Interval: 11.6 sec

Frequency Spectrum Parameters

<u>Probe Type:</u>	<u>Coil (AC)</u>	<u>Fluxgate (DC)</u>
Maximum Frequency (Hz)	2560	256
Minimum Frequency (Hz)	5	0
Spectral Bandwidth (Hz)	5	0.5

Missing or Suspect Data: The fluxgate sensor 3 m from the guideway was inoperative.

SETUP 24: LOW CONCRETE GUIDEWAY OUTSIDE MAINTENANCE FACILITY

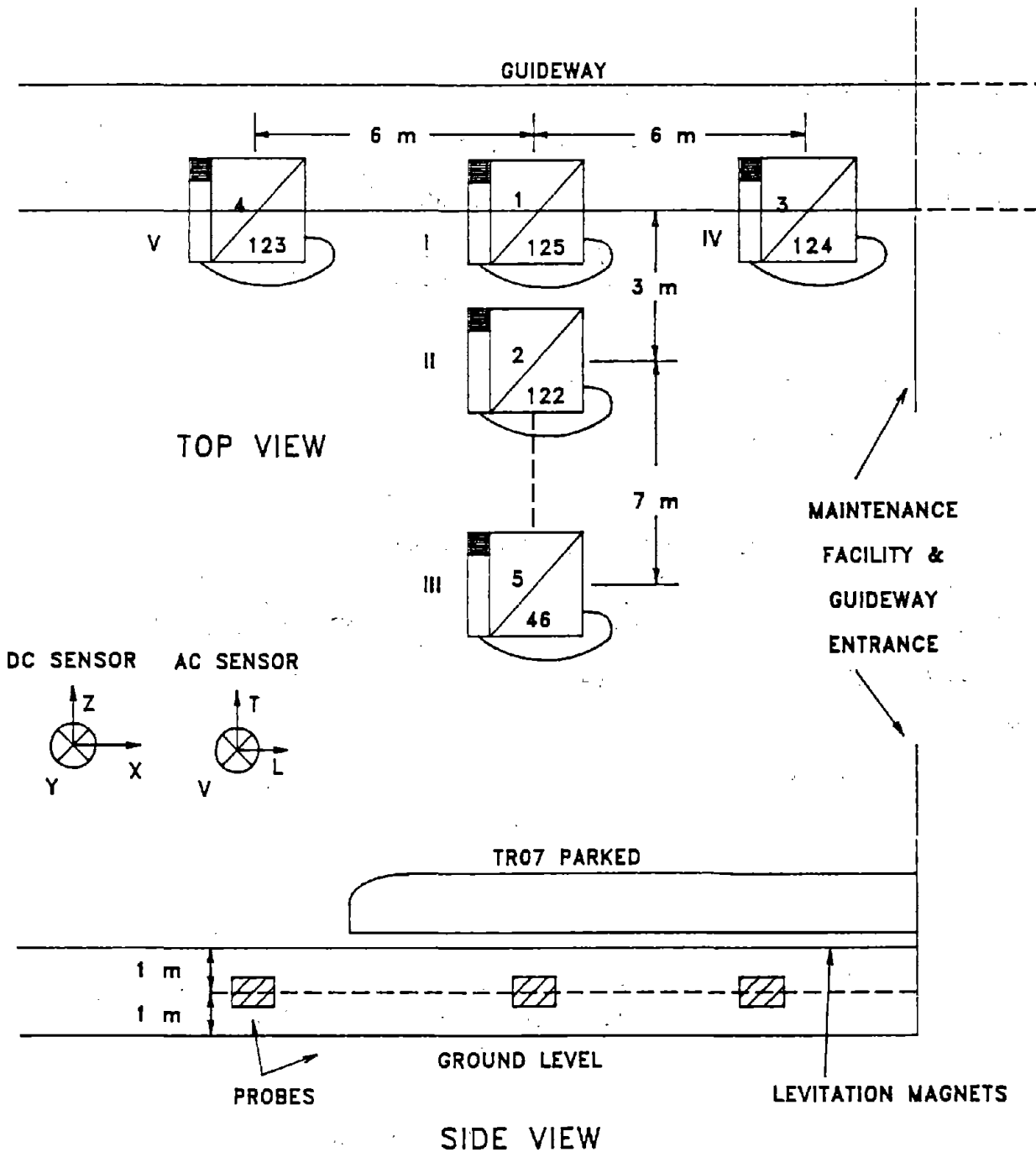

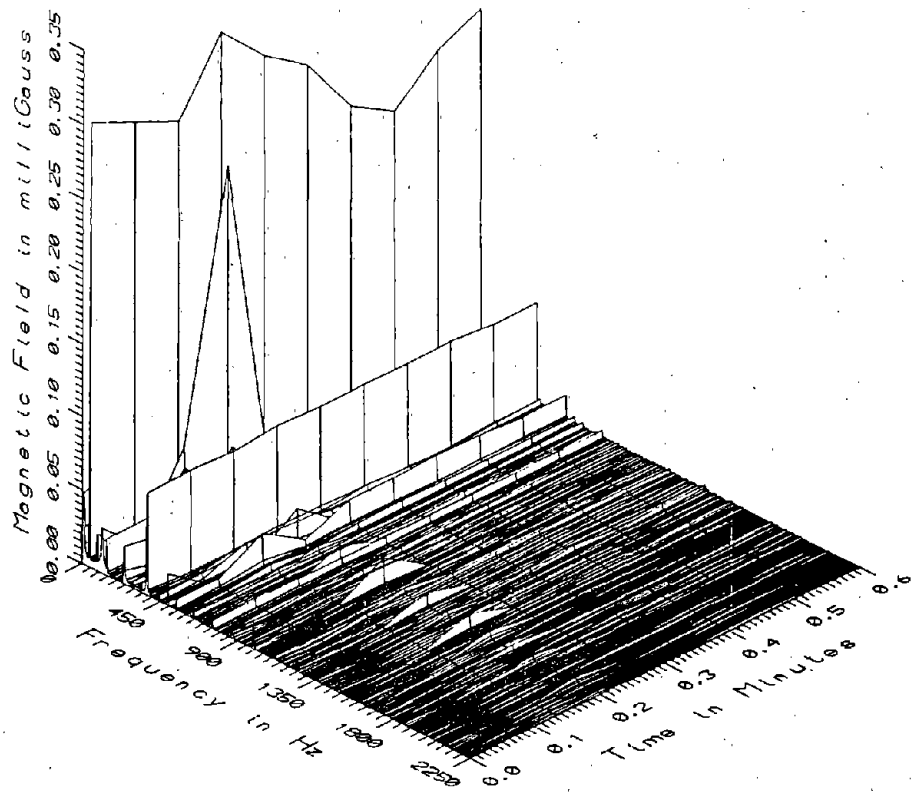

TR7025 - UNDER LOW CONCRETE GUIDEWAY OUTSIDE MAINTENANCE FACILITY

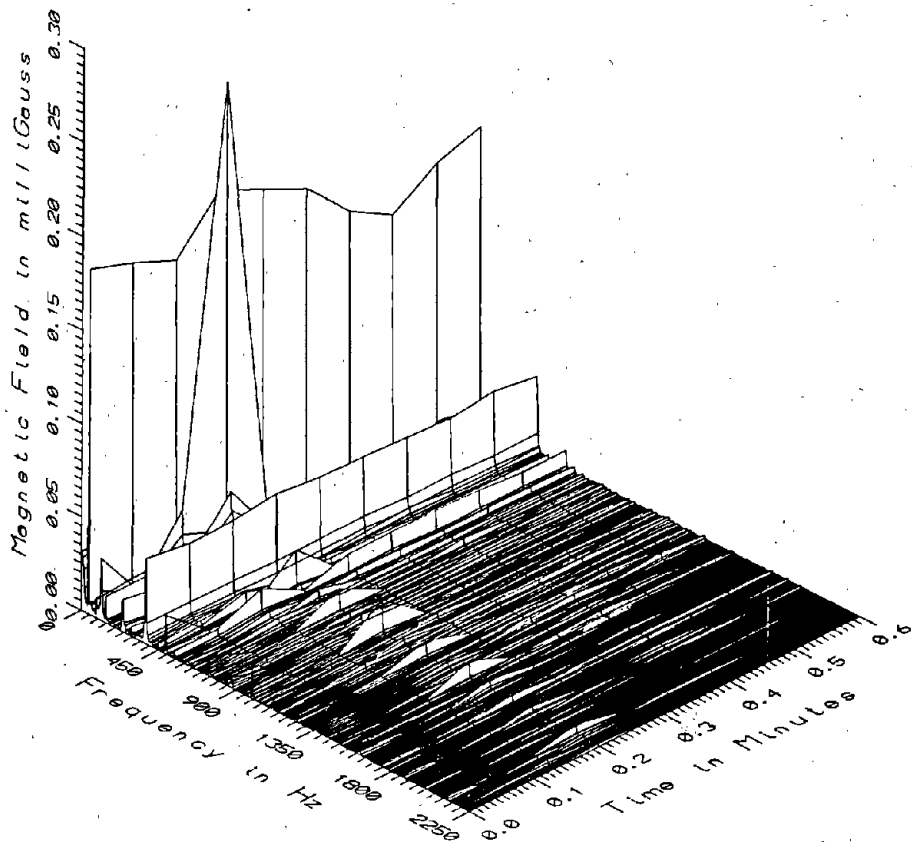

TR7025 - 3M NORTHWEST OF LOW CONCRETE GUIDEWAY OUTSIDE MAINTENANCE FACILITY

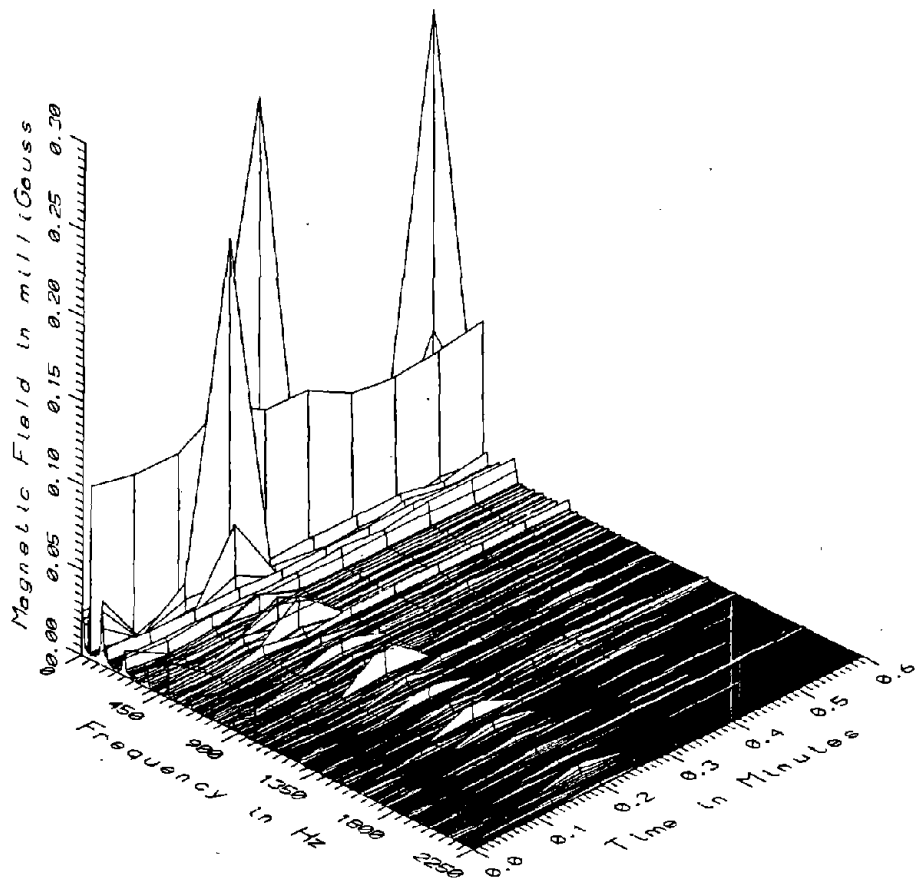

TR7025 - 10M NORTHWEST OF LOW CONCRETE G/W OUTSIDE MAINTENANCE FACILITY

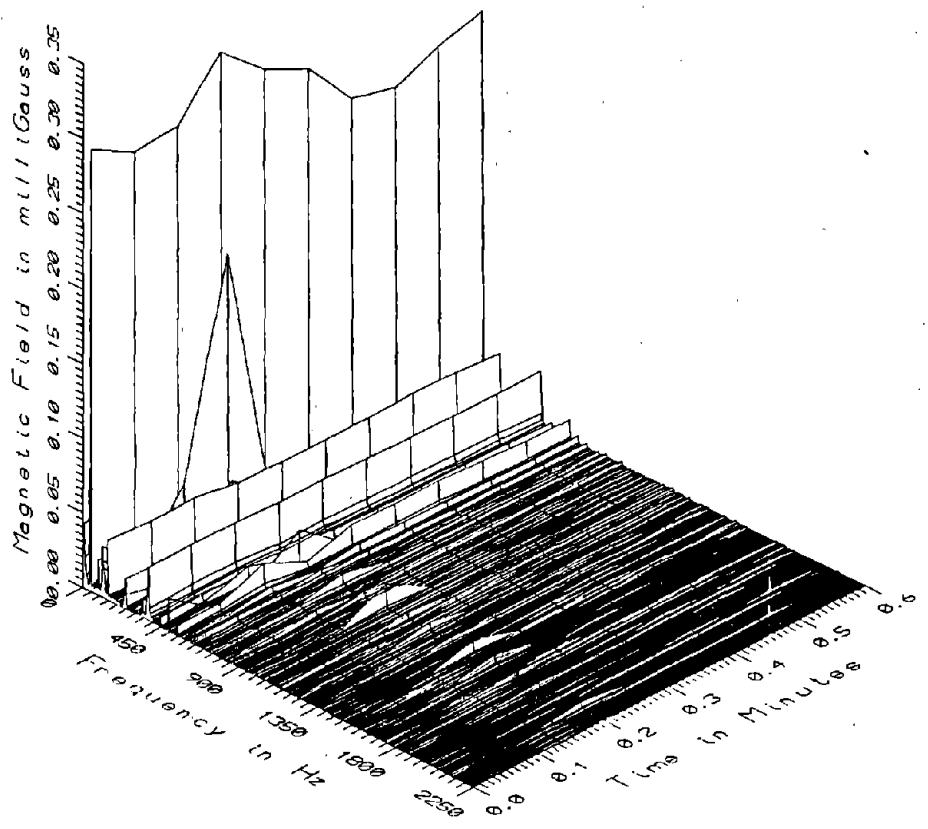

TR7025 - UNDER LOW CONCRETE G/W OUTSIDE MAINTENANCE FACILITY, 6M SW OF PROFILE

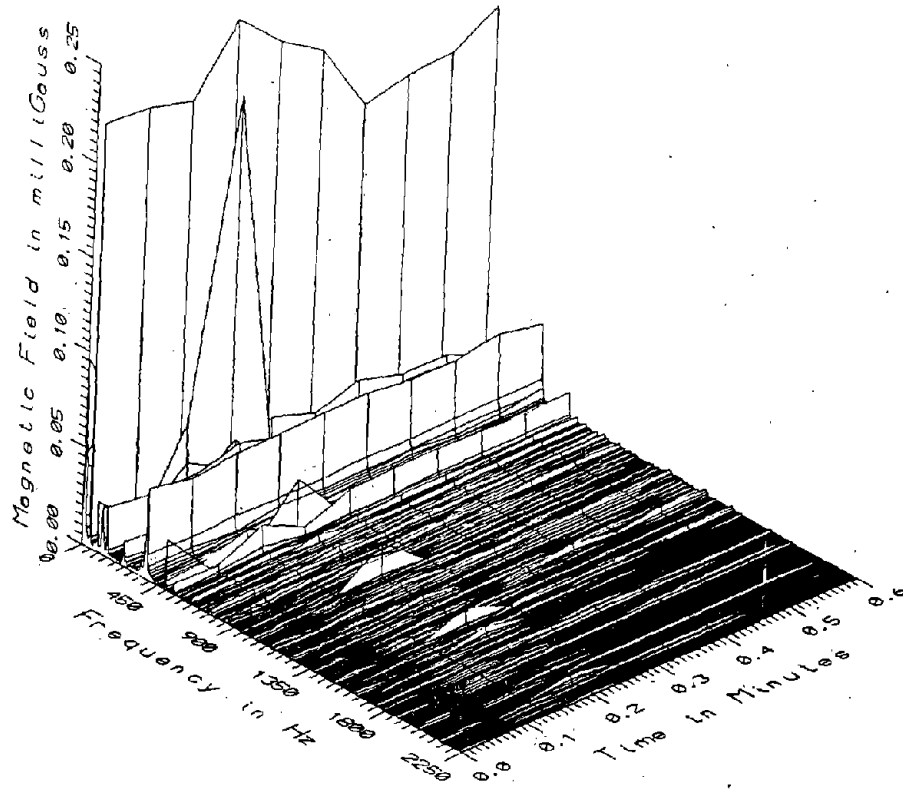

TR7025 - UNDER LOW CONCRETE G/W OUTSIDE MAINTENANCE FACILITY. 6M NE OF PROFILE

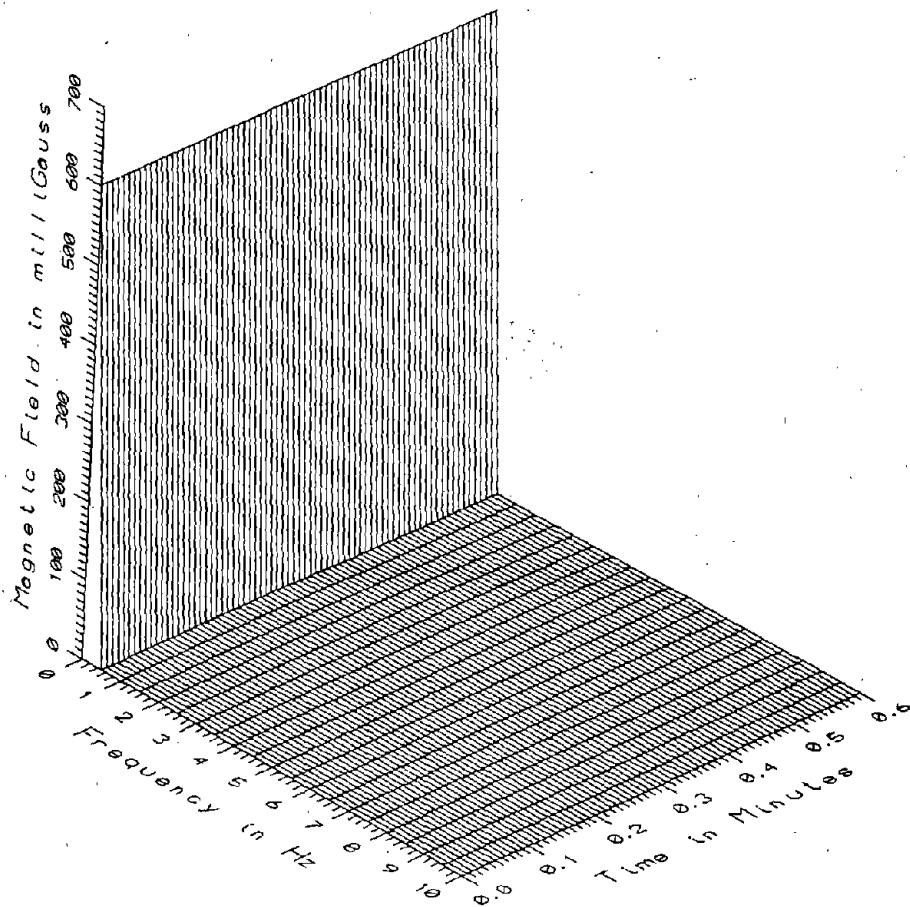

TR7025 - UNDER LOW CONCRETE G/W OUTSIDE MAINTENANCE FACILITY

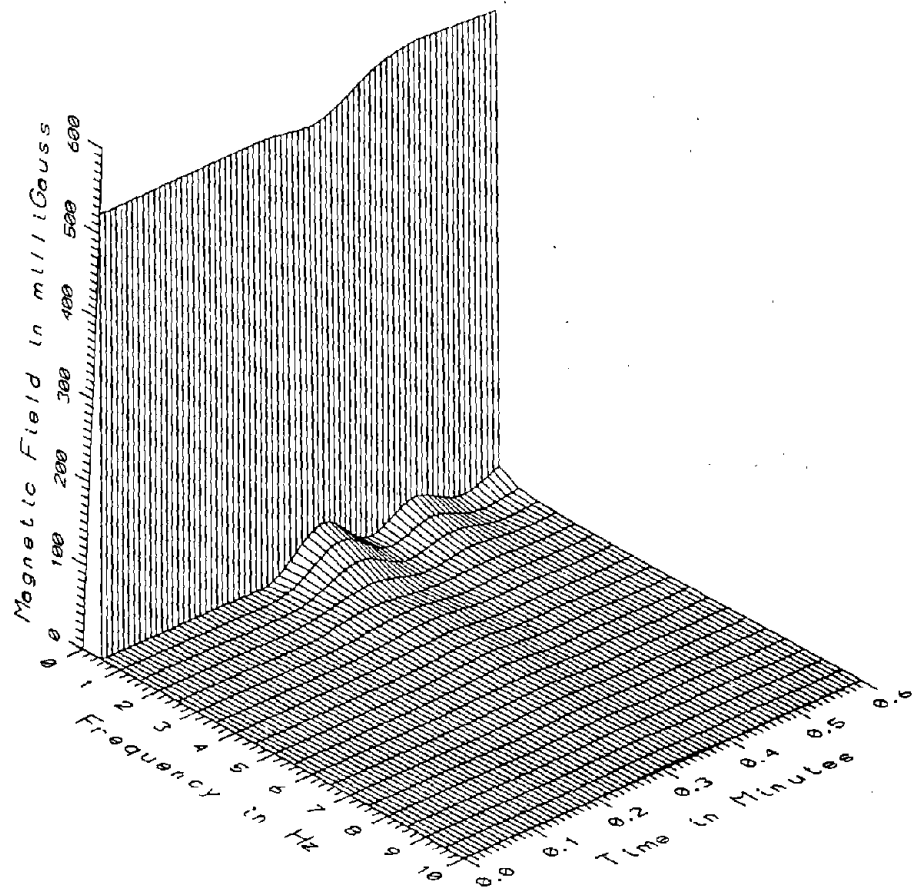

TR7025 - 10M NORTHWEST OF LOW CONCRETE GUIDEWAY OUTSIDE MAINTENANCE FACILITY

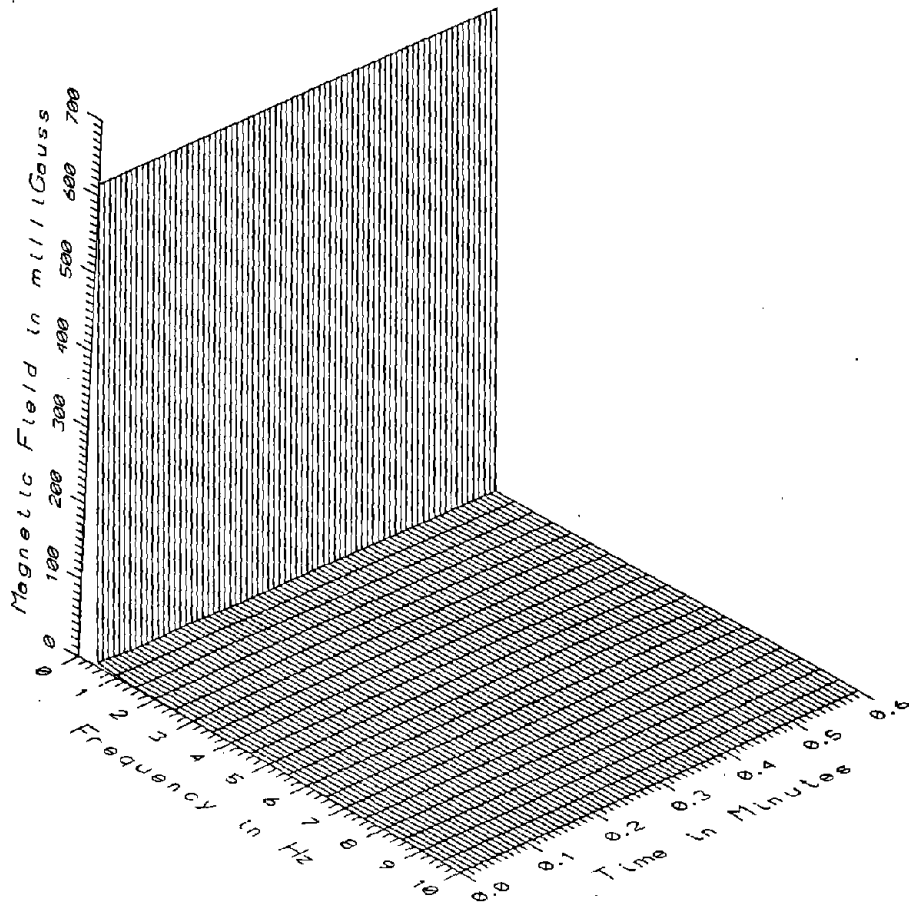

TR7025 - UNDER LOW CONCRETE G/W OUTSIDE MAINTENANCE FACILITY, 6M NE OF PROFILE U-6

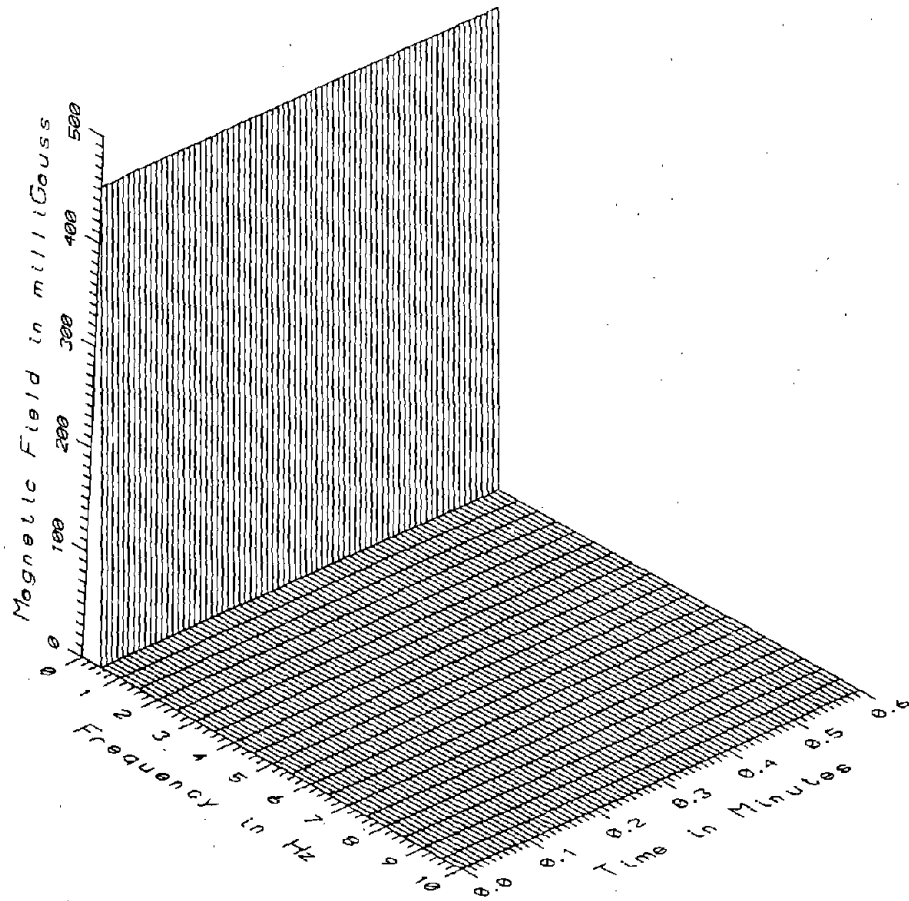

TR7025 - UNDER LOW CONCRETE G/W OUTSIDE MAINTENANCE FACILITY, 6M SW OF PROFILE

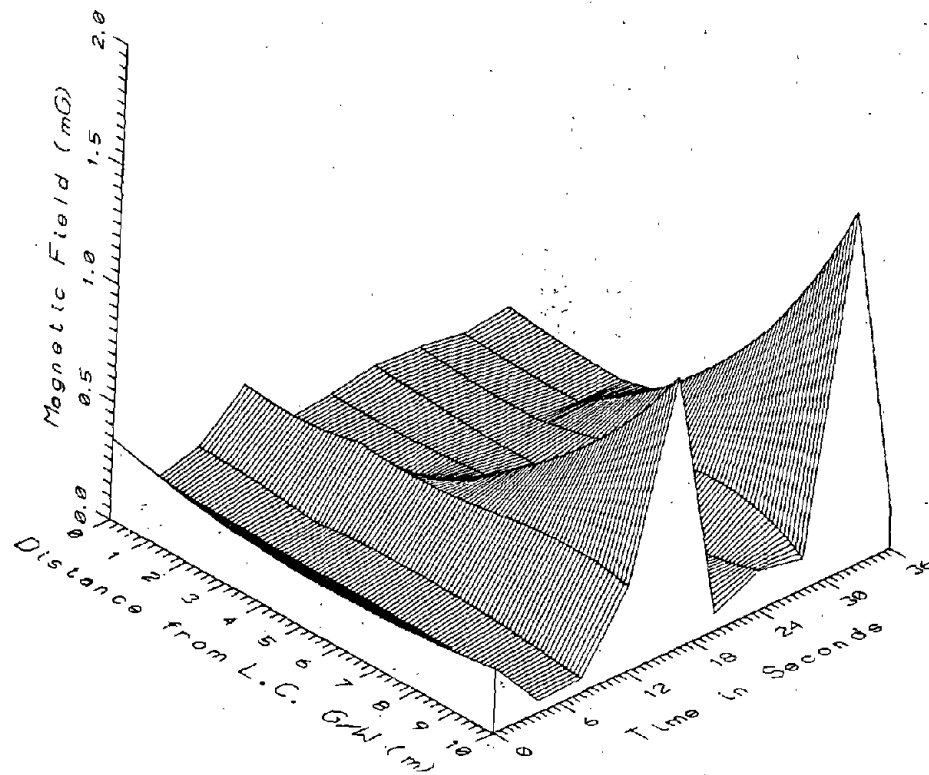

TR7025, LOW CONCRETE G/W OUTSIDE MAINTENANCE FACILITY - LOW FREQUENCY 5-45Hz

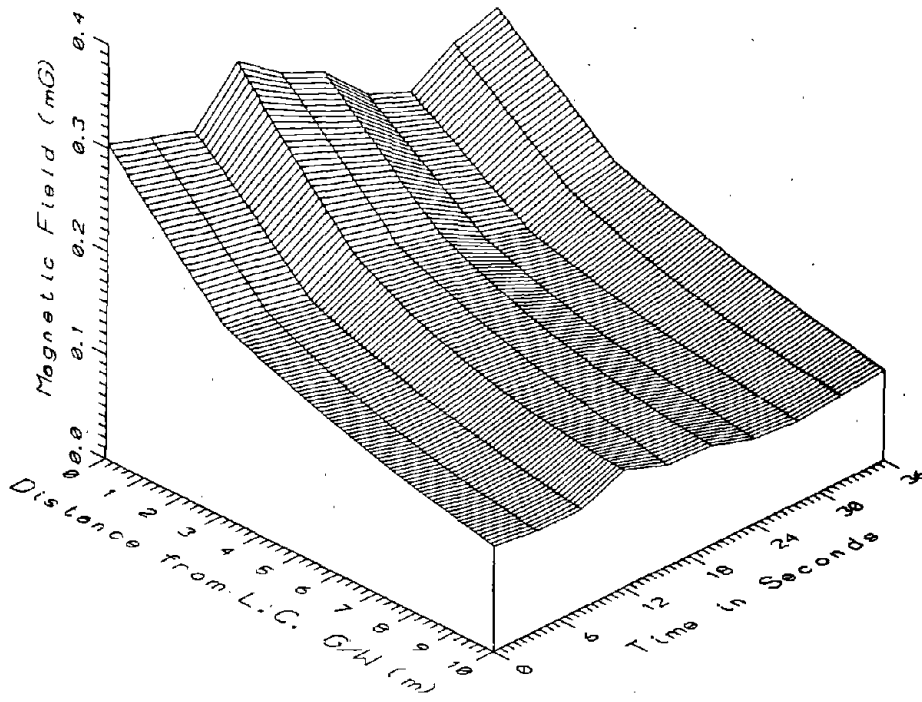

TR7025, LOW CONCRETE G/W OUTSIDE MAINTENANCE FACILITY - POWER FREQUENCY 50-60Hz

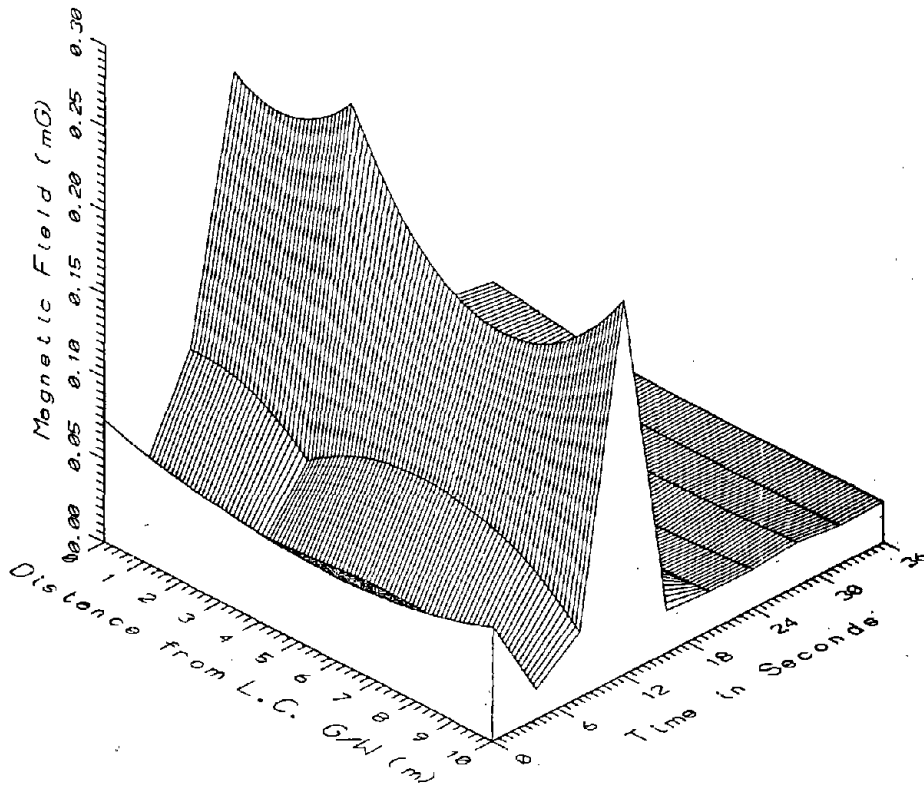

TR7025, LOW CONCRETE G/W OUTSIDE MAINTENANCE FACILITY - POWER HARM 65-300Hz

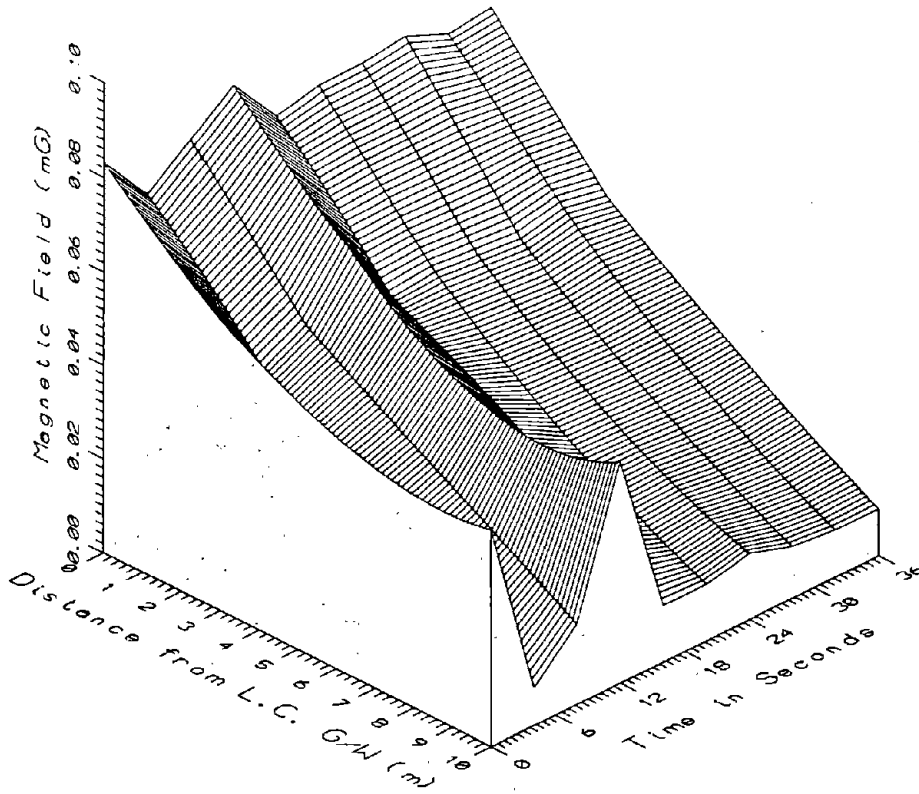

TR7025, LOW CONCRETE G/W OUTSIDE MAINTENANCE FACILITY - HIGH FREQ 305-2560Hz

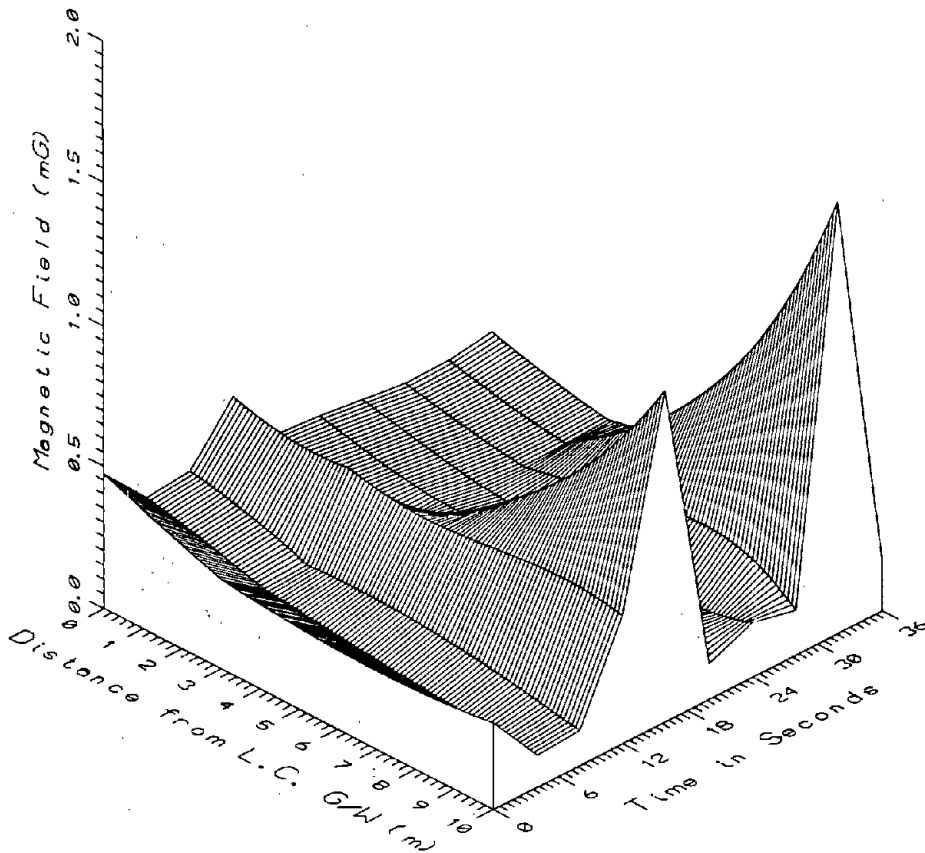

TR7025, LOW CONCRETE G/W OUTSIDE MAINTENANCE FACILITY - ALL FREQ 5-2560Hz

APPENDIX V

DATA SET TR7026

**LATERAL PROFILE
BENEATH THE LOW CONCRETE GUIDEWAY
WITH THE VEHICLE LEVITATING**

Vol

APPENDIX V

DATA SET TR7026
LATERAL PROFILE BENEATH THE LOW CONCRETE GUIDEWAY
WITH THE VEHICLE LEVITATING

Measurement Setup Code: 24
Vehicle Status: Levitating overhead
Measurement Date: August 9, 1990
Measurement Time: Start: 18:06:10
End: 18:10:34
Number of Samples: 39
Programmed Sample Interval: 4 sec
Actual Sample Interval: 7.2 sec

Frequency Spectrum Parameters

<u>Probe Type:</u>	<u>Coil (AC)</u>	<u>Fluxgate (DC)</u>
Maximum Frequency (Hz)	2560	256
Minimum Frequency (Hz)	5	0
Spectral Bandwidth (Hz)	5	0.5

Missing or Suspect Data: The fluxgate probe 3 m from the guideway was inoperative and the vertical axis of the fluxgate sensor along the guideway but 6 m northeast of the profile was saturated on 3 of 39 samples.

SETUP 24: LOW CONCRETE GUIDEWAY OUTSIDE MAINTENANCE FACILITY

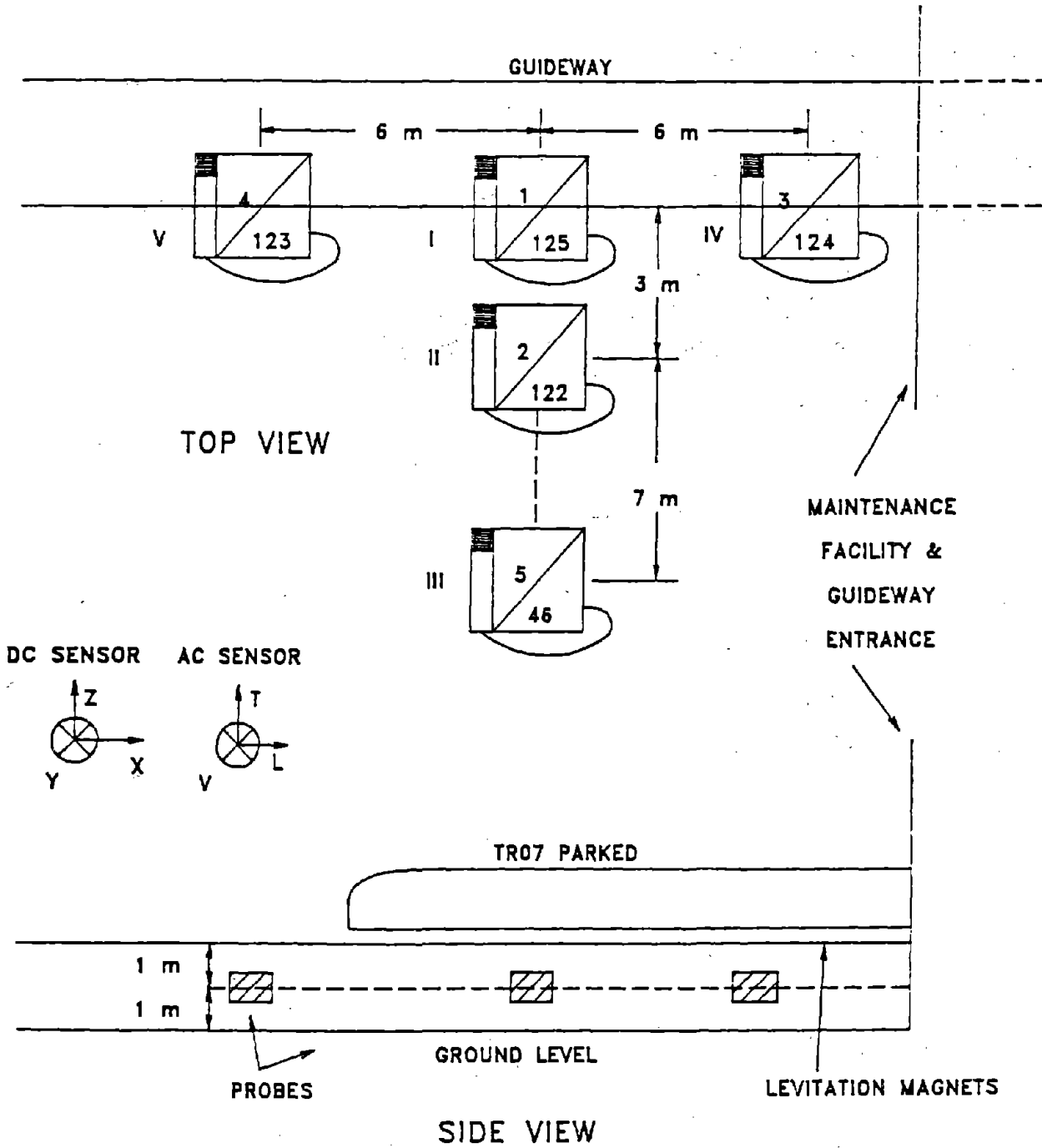

V-2

Reproduced from
best available copy.

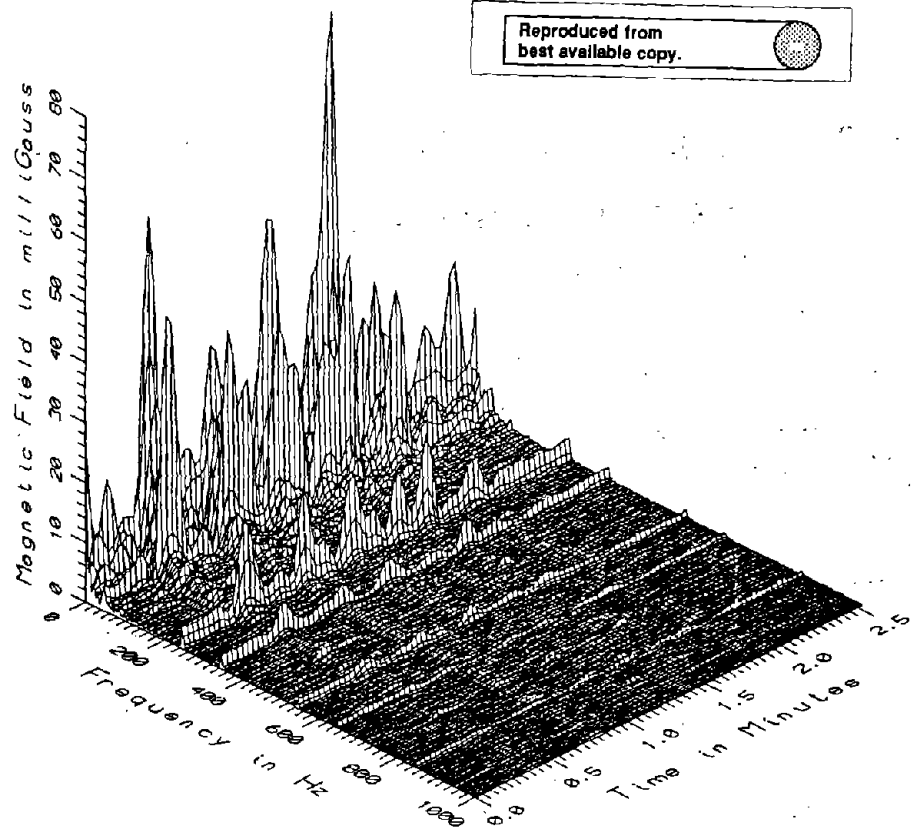

TR7026 - UNDER LOW CONCRETE GUIDEWAY OUTSIDE MAINTENANCE FACILITY

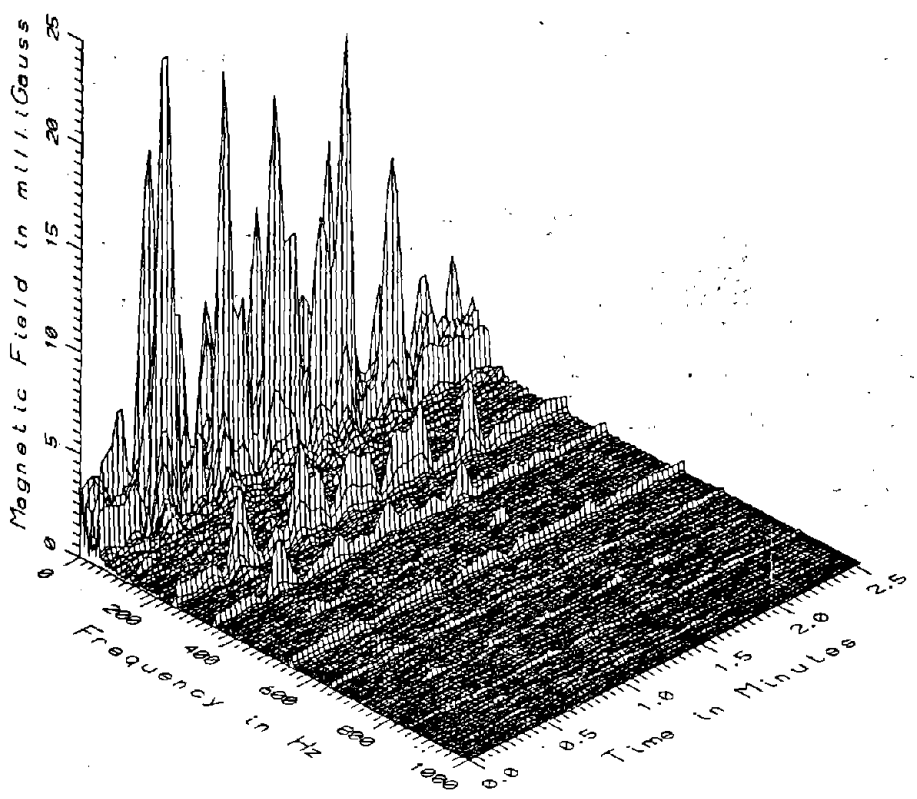

TR7026 - 3M NORTHWEST OF LOW CONCRETE GUIDEWAY OUTSIDE MAINTENANCE FACILITY

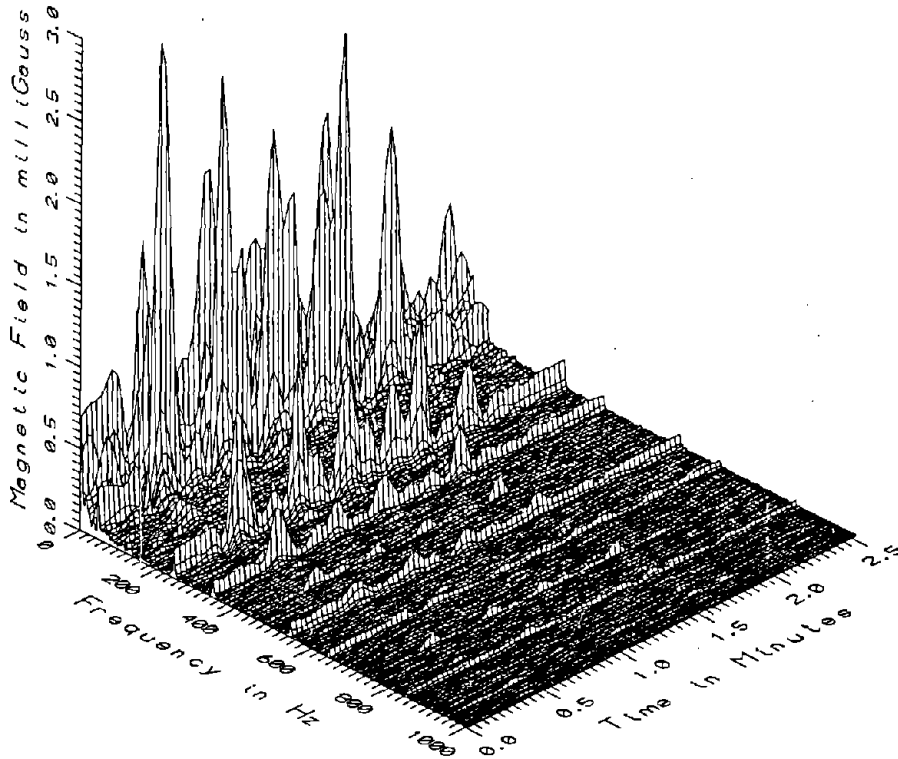

TR7026 - 10M NORTHWEST OF LOW CONCRETE GUIDEWAY OUTSIDE MAINTANENCE FACILITY

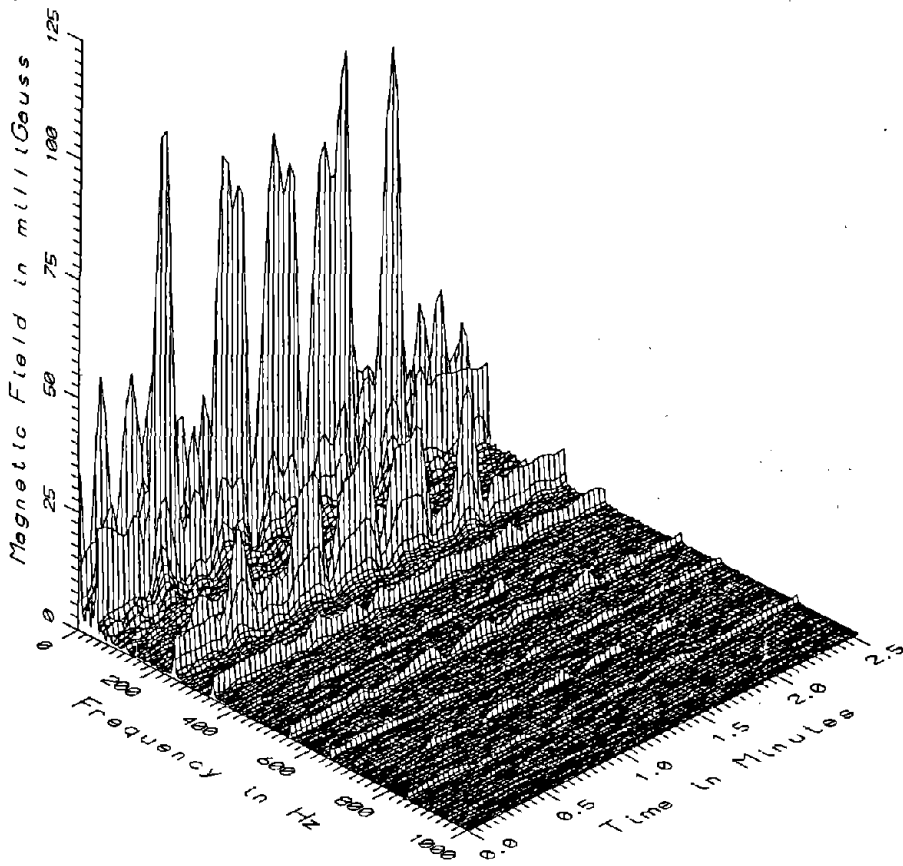

TR7026 - UNDER LOW CONCRETE G/W OUTSIDE MAINTANENCE FACILITY, 6M NE OF PROFILE

v-4

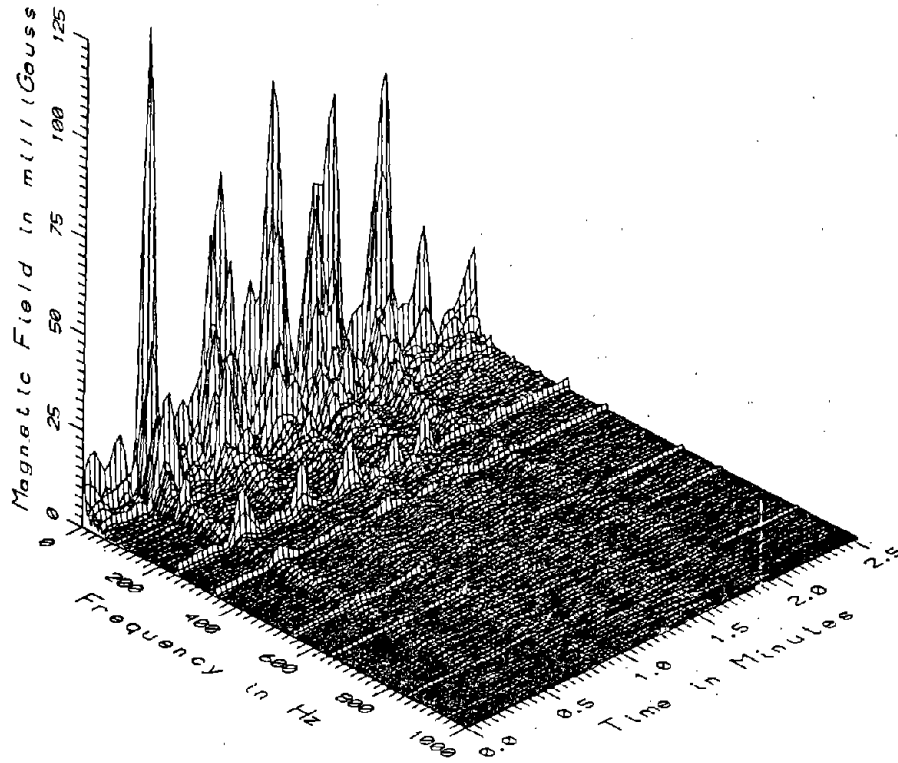

TR7026 - UNDER LOW CONCRETE G/W OUTSIDE MAINTENANCE FACILITY, 6M SW OF PROFILE

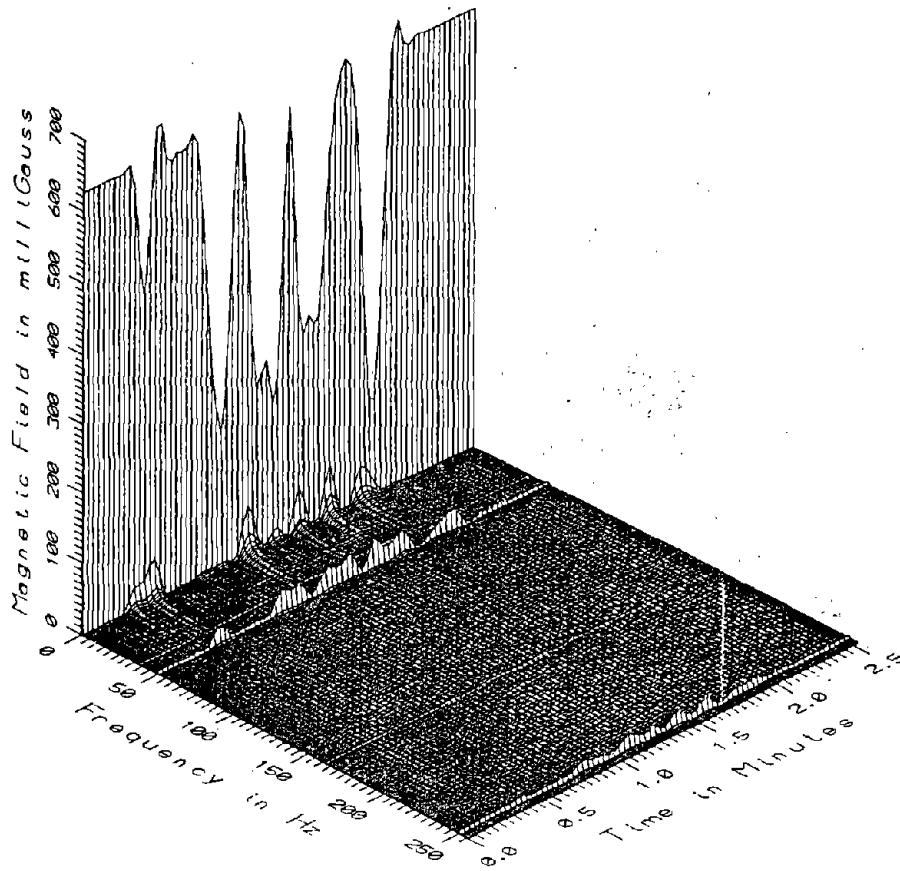

TR7026 - UNDER LOW CONCRETE G/W OUTSIDE MAINTENANCE FACILITY

V-5

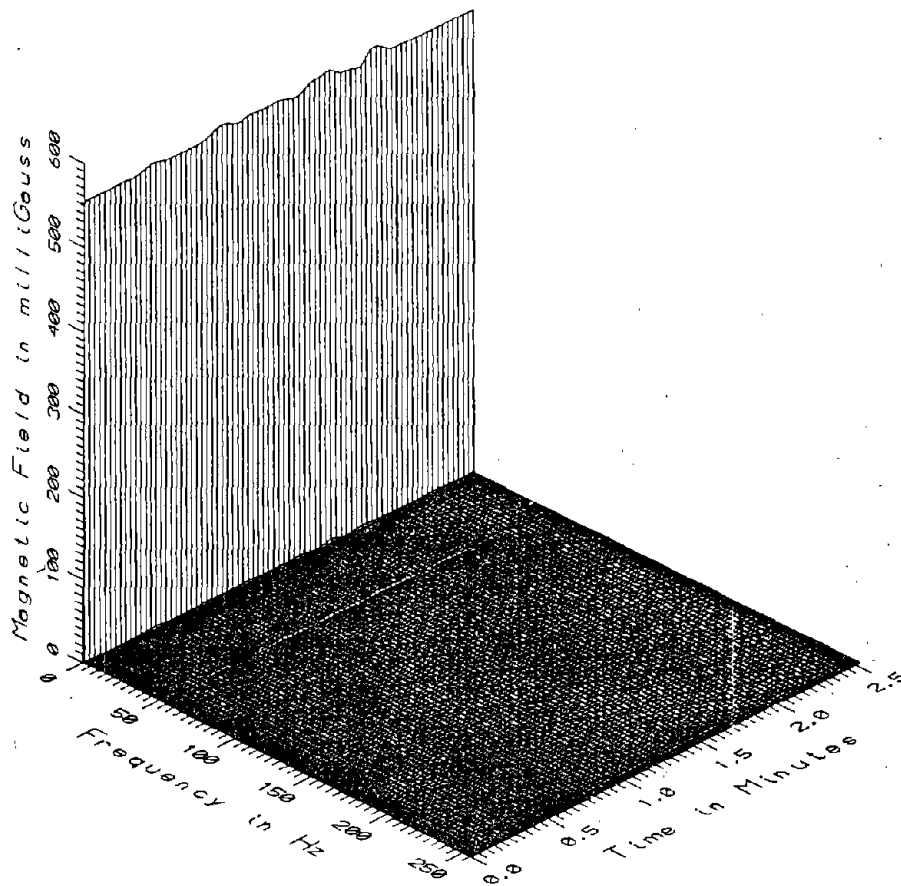

TR7026 - 10M NORTHWEST OF LOW CONCRETE GUIDEWAY OUTSIDE MAINTENANCE FACILITY

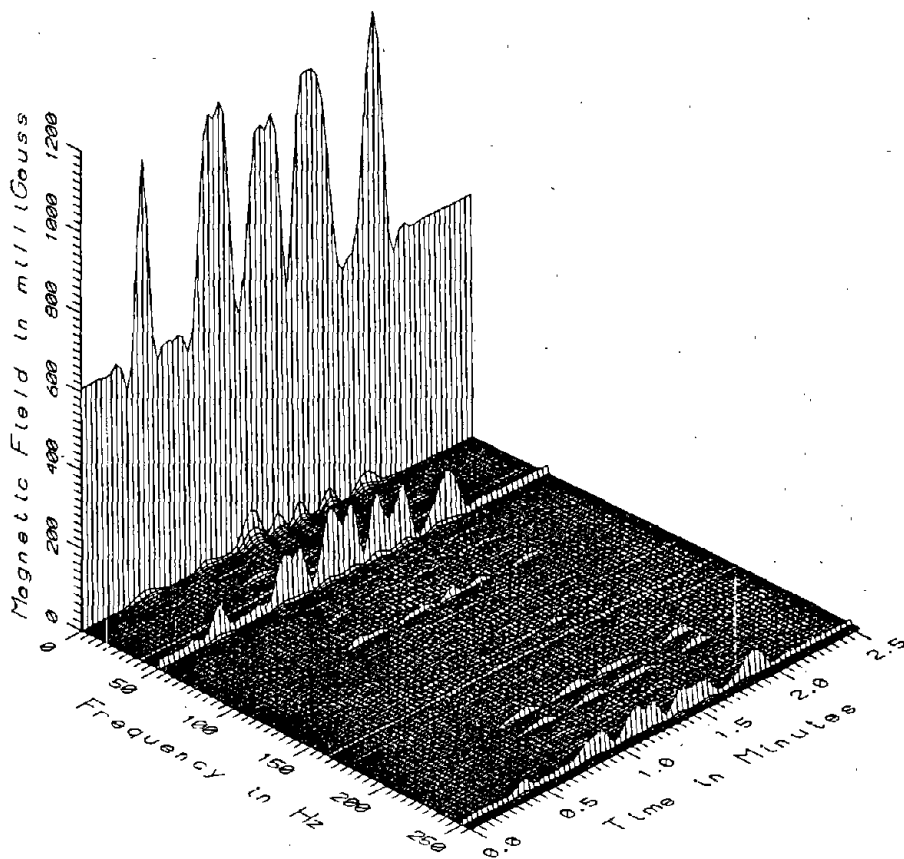

TR7026 - UNDER LOW CONCRETE G/W OUTSIDE MAINTENANCE FACILITY, 6M NE OF PROF III

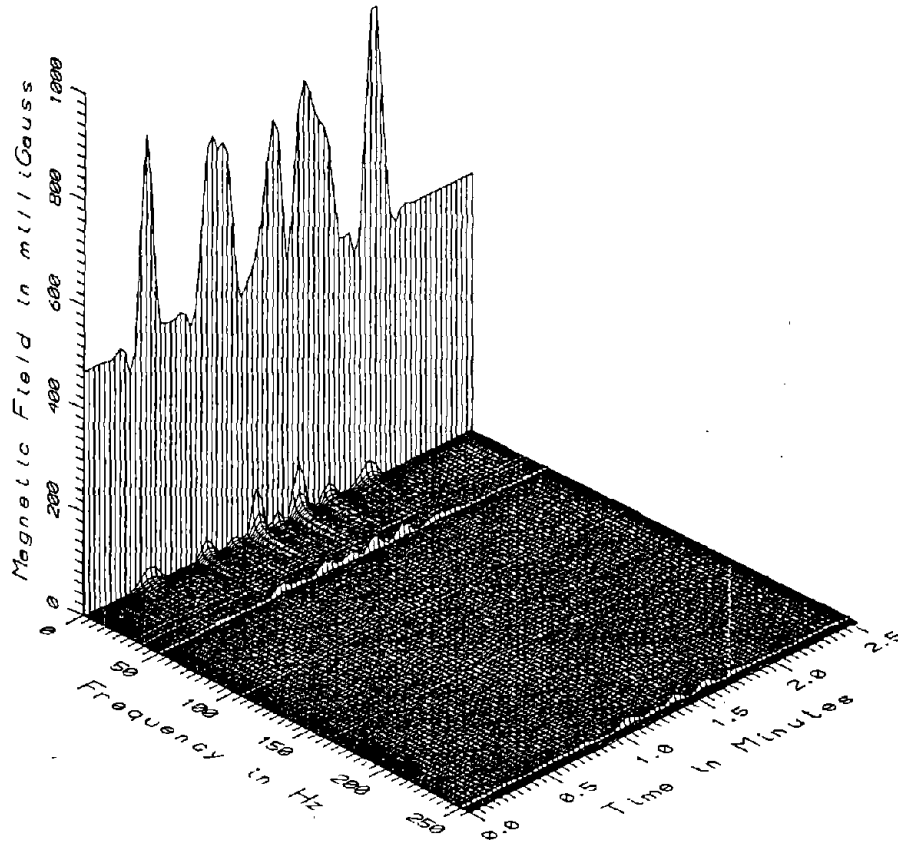

TR7026 - UNDER LOW CONCRETE G/W OUTSIDE MAINTENANCE FACILITY, 6M SW OF PROFILE

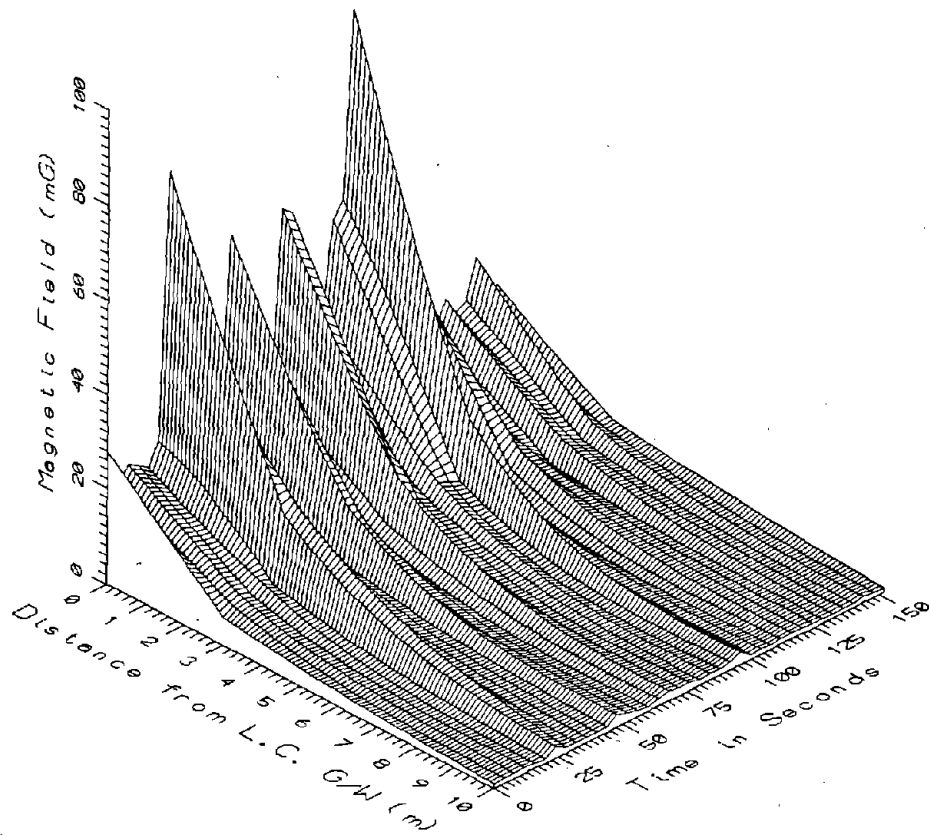

TR7026, LOW CONCRETE G/W OUTSIDE MAINTENANCE FACILITY - LOW FREQ. 6-45Hz

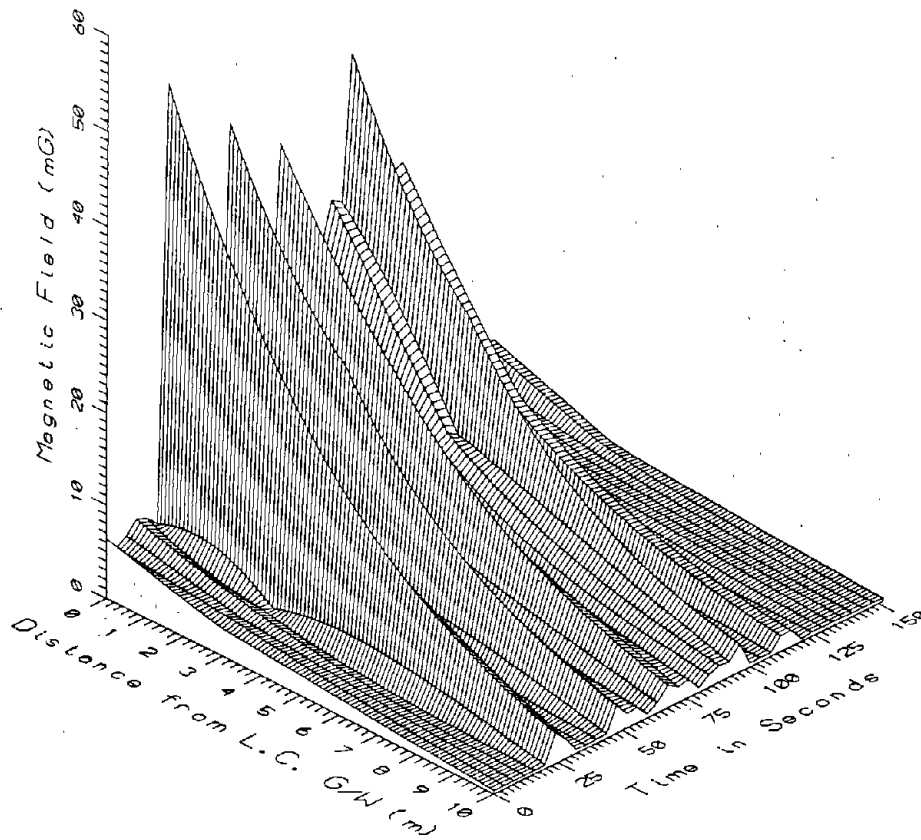

TR7026, LOW CONCRETE G/W OUTSIDE MAINTENANCE FACILITY - POWER FREQ, 48-60Hz

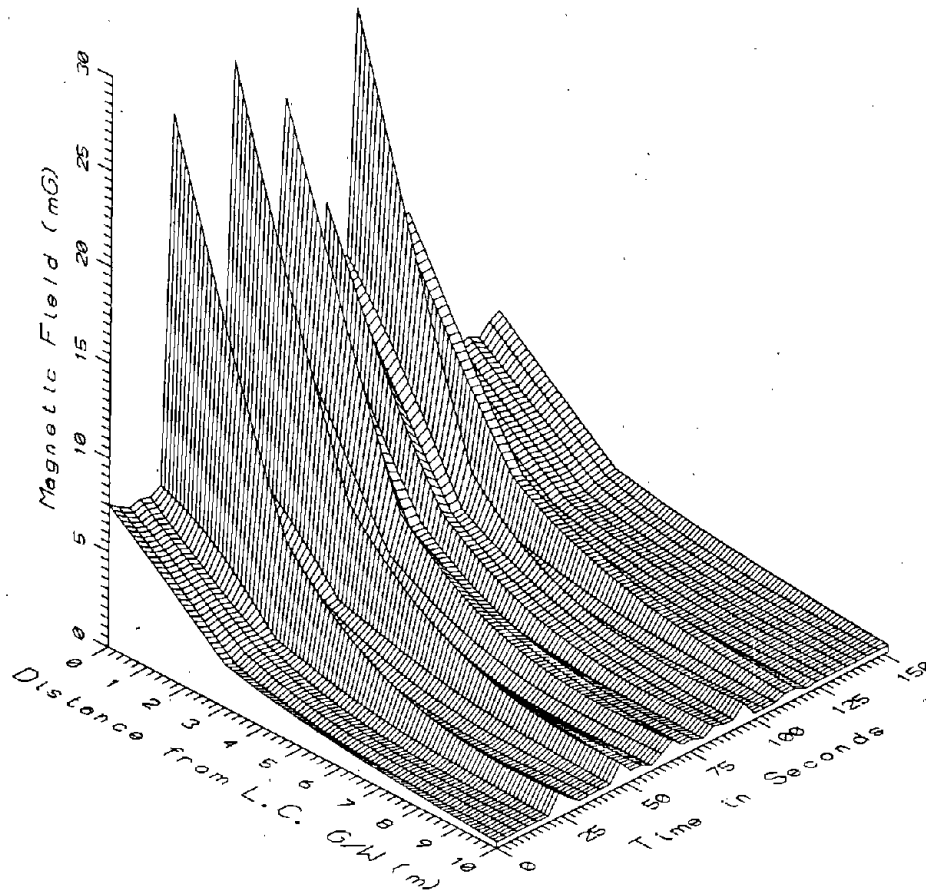

TR7026, LOW CONCRETE G/W OUTSIDE MAINTENANCE FACILITY - POWER HARM, 60-300Hz

U-8

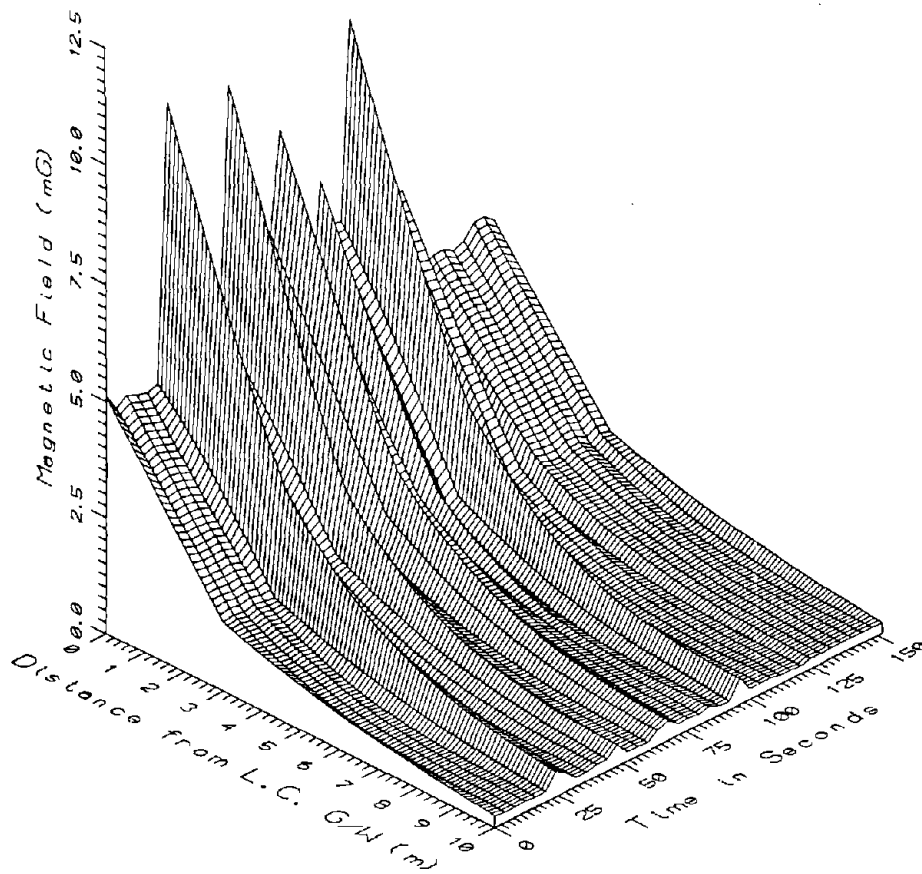

TR7026, LOW CONCRETE G/W OUTSIDE MAINTENANCE FACILITY - HIGH FREQ., 303-1536Hz

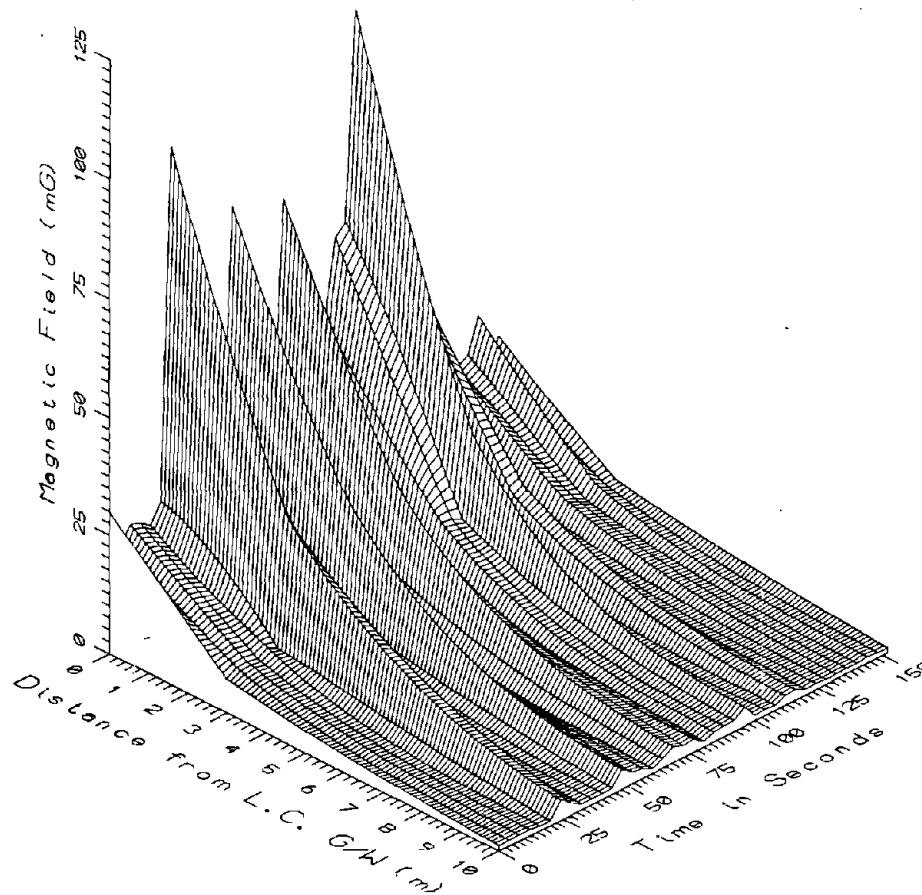

TR7026, LOW CONCRETE G/W OUTSIDE MAINTENANCE FACILITY - ALL FREQ., 6-1536Hz

W-1

APPENDIX W

DATA SET TR7028

**MEASUREMENTS NEAR THE INVERTER BUILDING
AND FEEDER CABLES**

W-1

APPENDIX W

DATA SET TR7028
MEASUREMENTS NEAR THE INVERTER BUILDING AND FEEDER CABLES

Measurement Setup Code: 26
Vehicle Status: Running continuously
Measurement Date: August 10, 1990
Measurement Time: Start: 10:05:30
End: 10:05:58
Number of Samples: 6
Programmed Sample Interval: 4 sec
Actual Sample Interval: 5.6 sec

Frequency Spectrum Parameters

<u>Probe Type:</u>	<u>Coil (AC)</u>	<u>Fluxgate (DC)</u>
Maximum Frequency (Hz)	2560	256
Minimum Frequency (Hz)	5	0
Spectral Bandwidth (Hz)	5	0.5

Missing or Suspect Data: The fluxgate sensor 15 m north of the inverter building and 2 m west of the feeder cables was inoperative.

SETUP 25 AND 26: OUTSIDE INVERTER BUILDING ALONG MAIN FEEDER CABLES

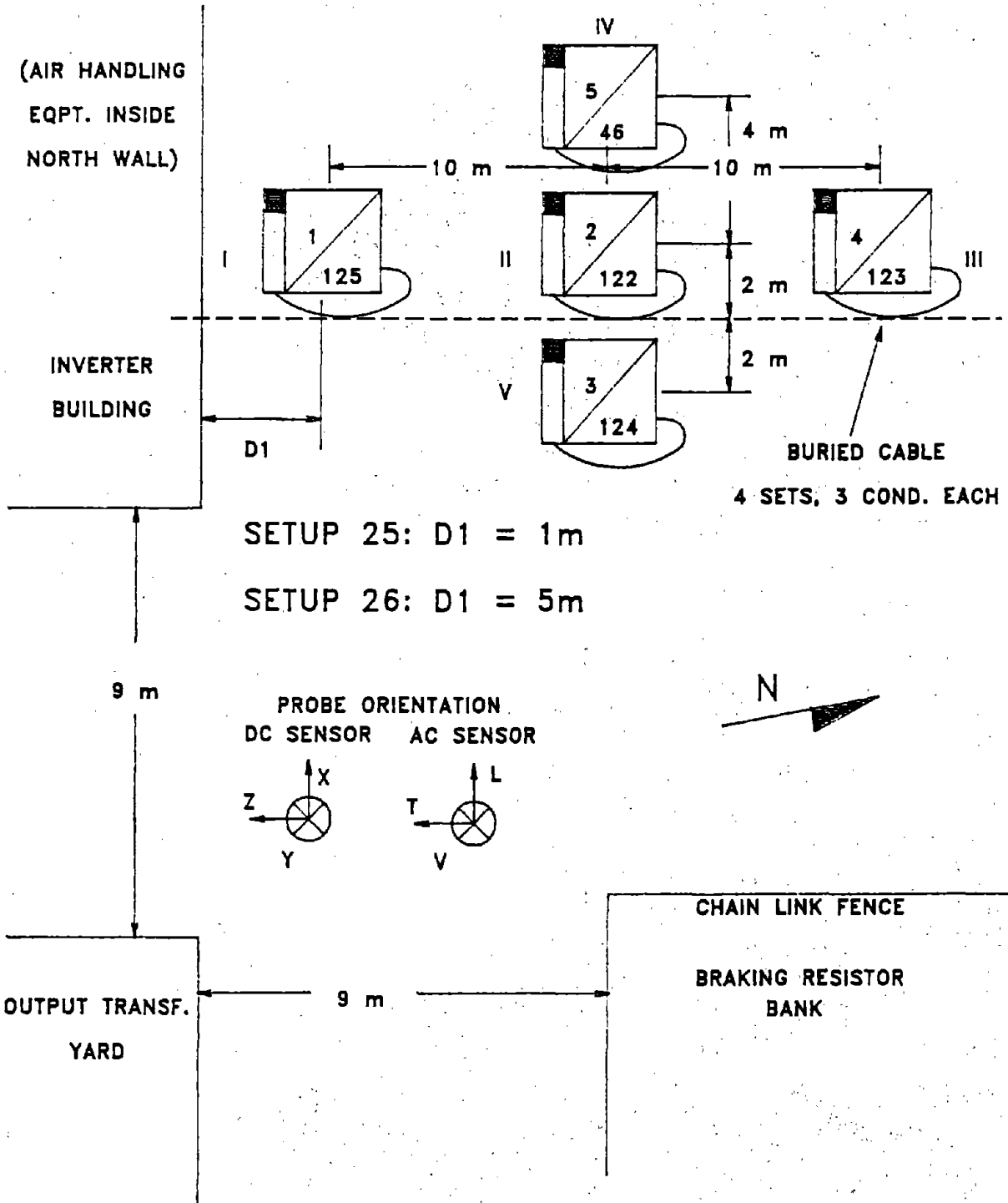

W-2

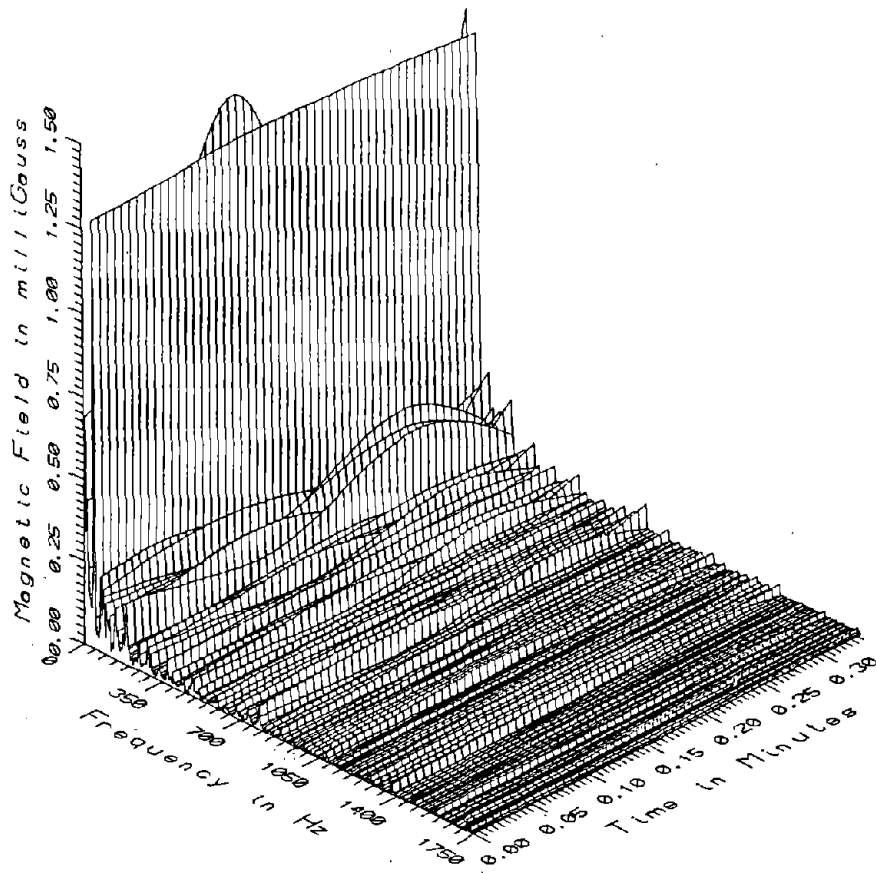

TR7028 - 5M NORTH OF INVERTER BUILDING

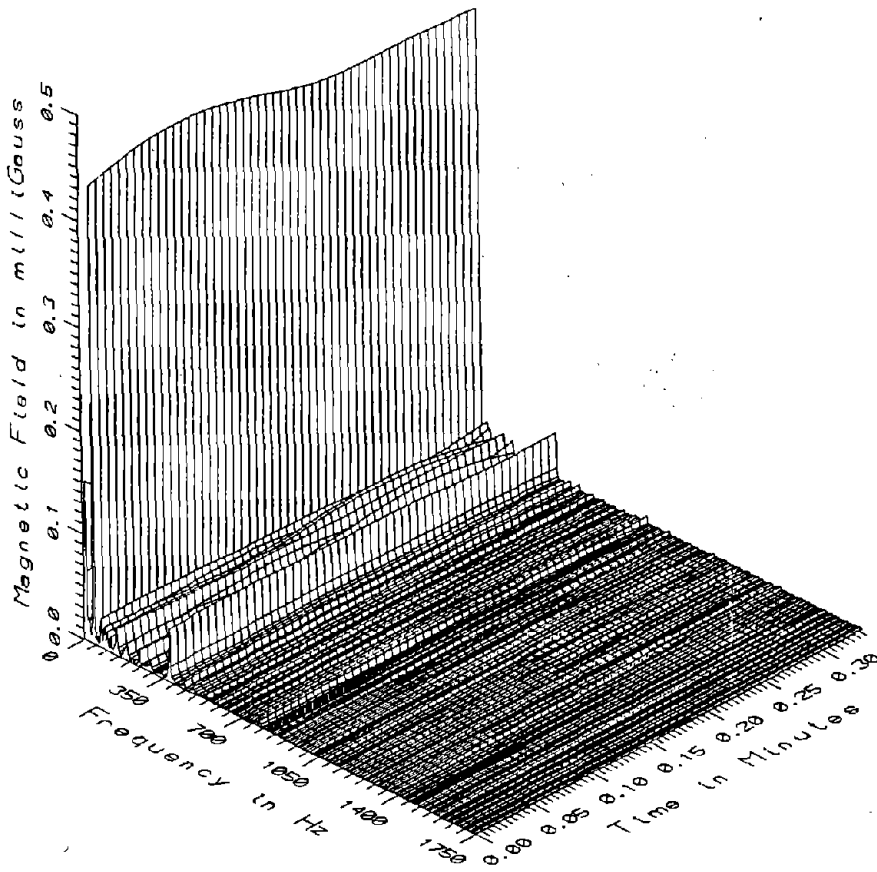

TR7028 - 15M NORTH OF INVERTER BUILDING

W-3

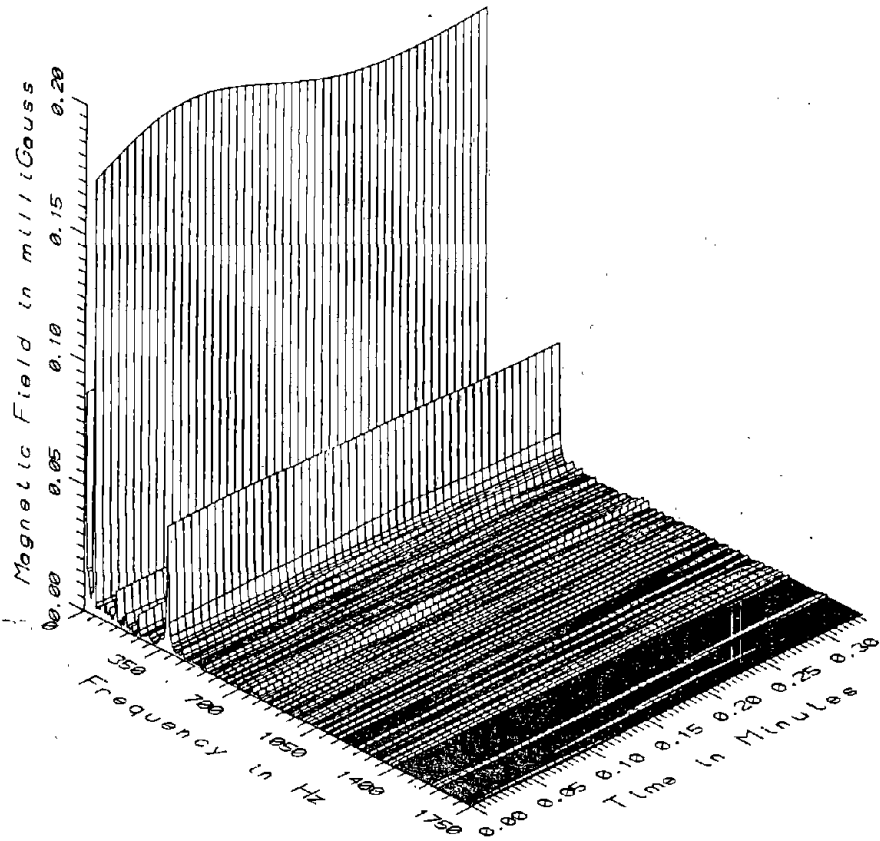

TR7028 - 25M NORTH OF INVERTER BUILDING

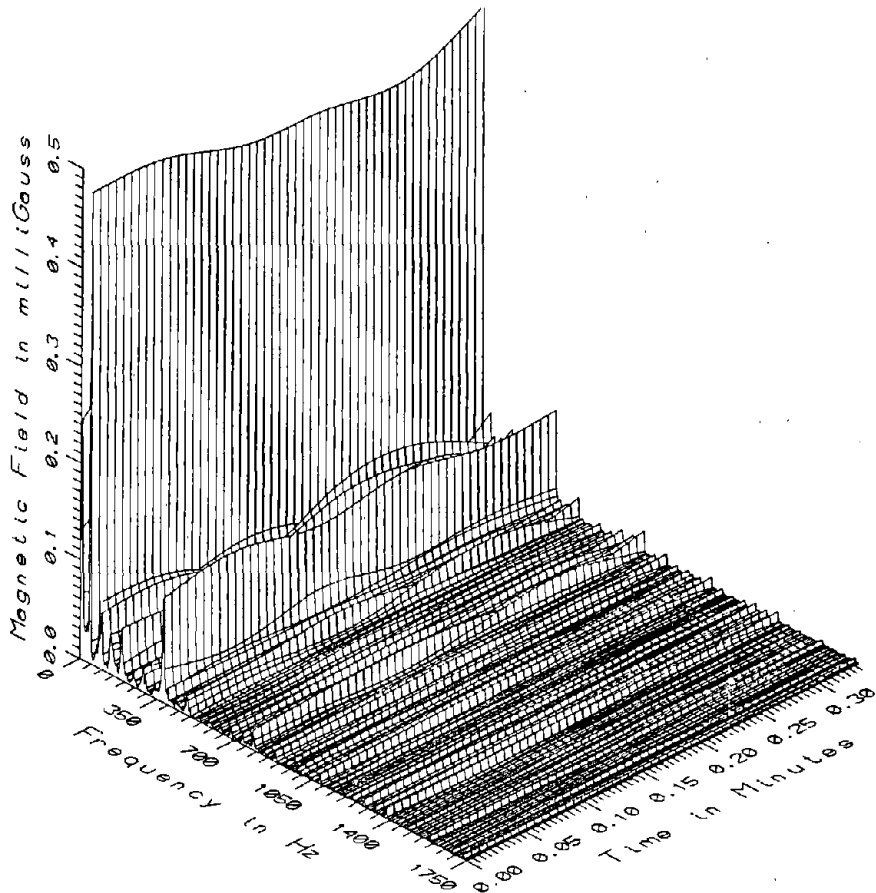

TR7028 - 15M NORTH OF INVERTER BUILDING, 4M EAST OF PROFILE

W-4

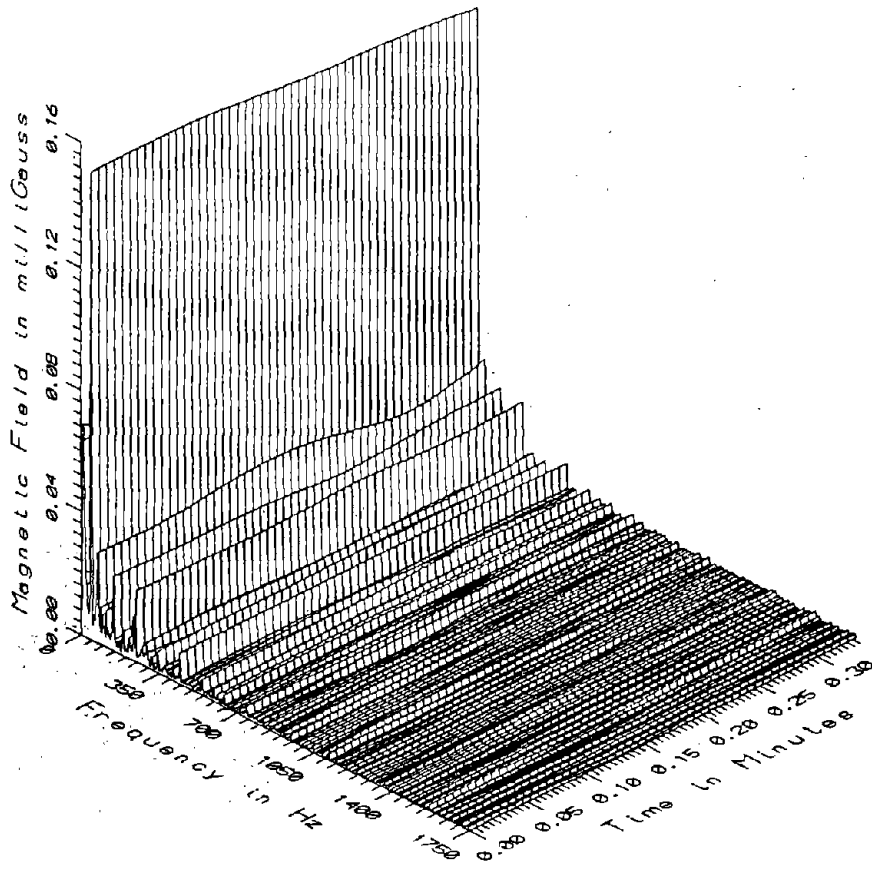

TR7028 - 15M NORTH OF INVERTER BUILDING, 4M WEST OF PROFILE

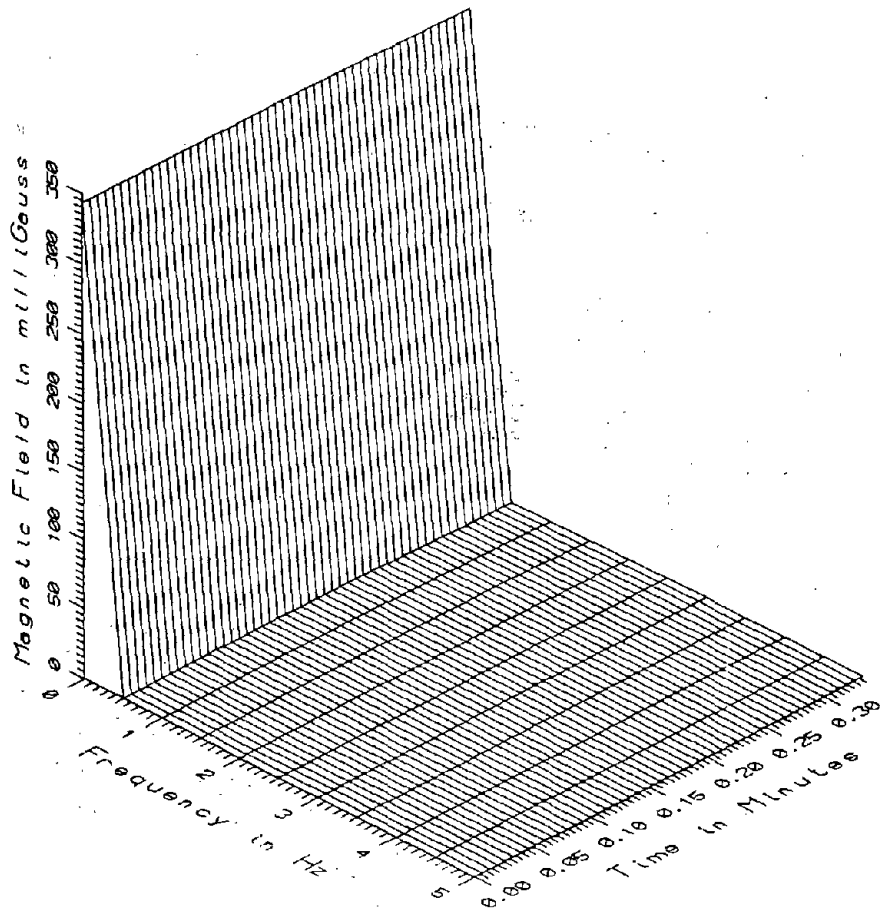

TR7028 - 5M NORTH OF INVERTER BUILDING

W-5

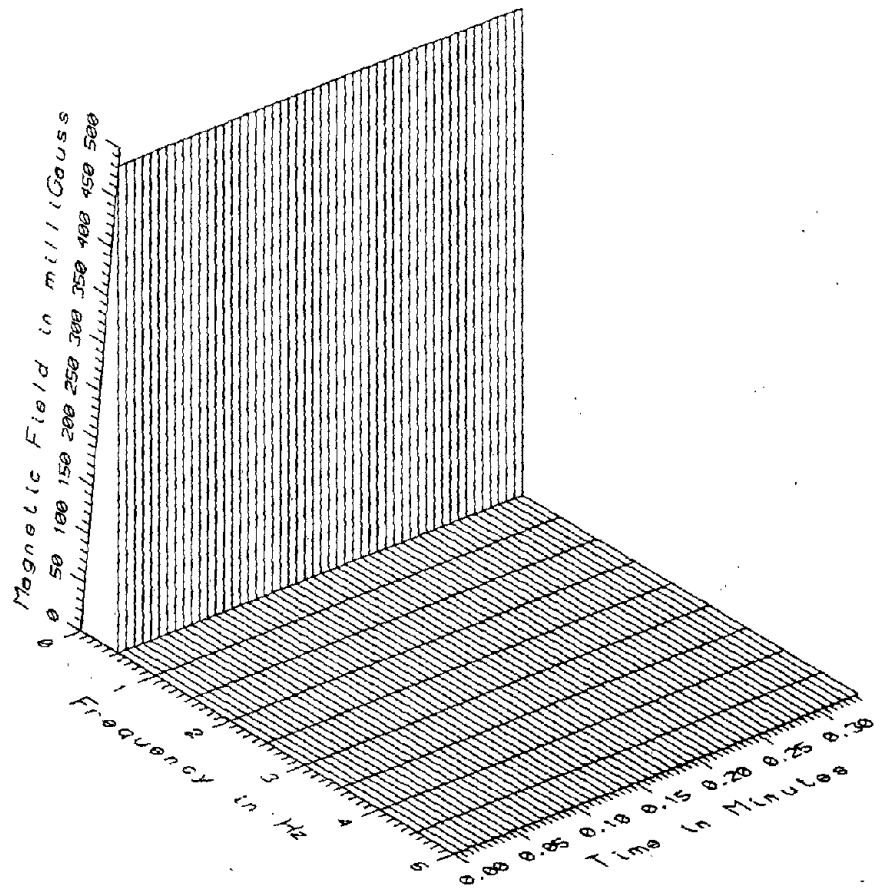

TR7028 - 25M NORTH OF INVERTER BUILDING

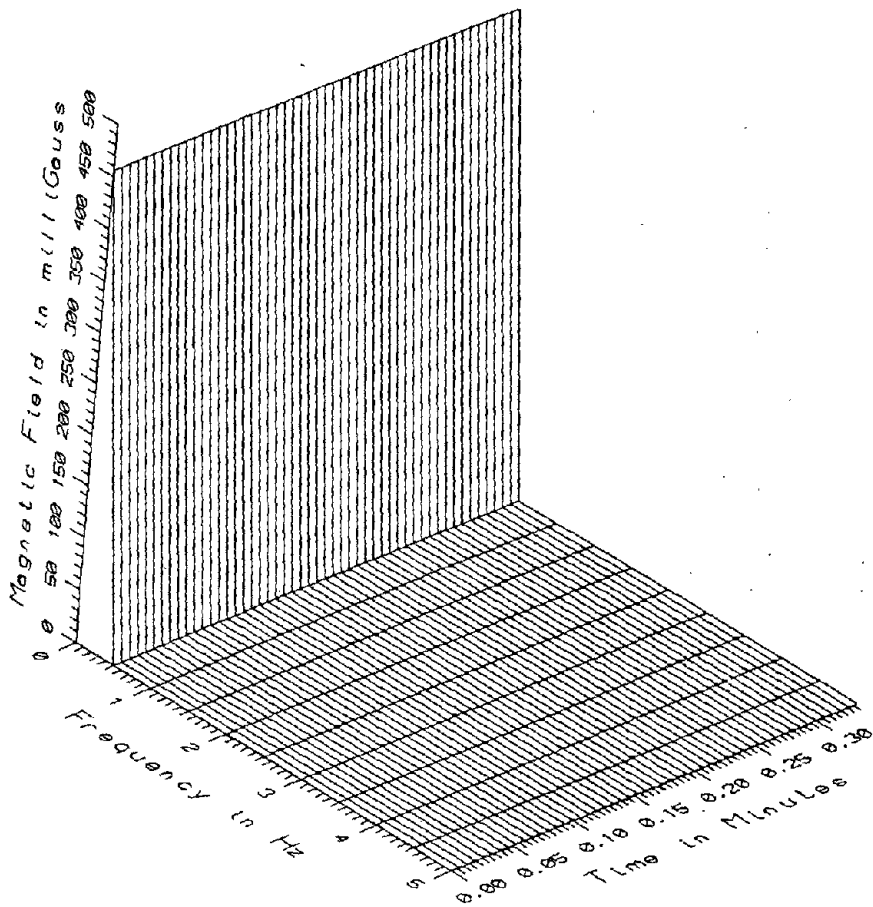

TR7028 - 15M NORTH OF INVERTER BUILDING, 4M EAST OF PROFILE

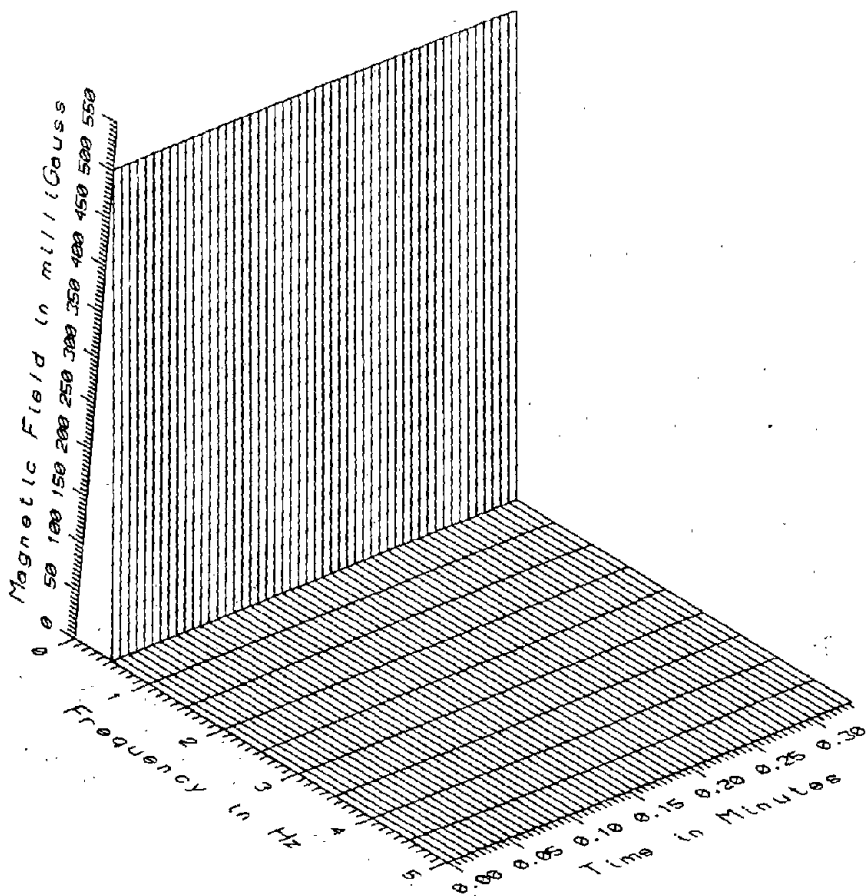

TR7028 - 15M NORTH OF INVERTER BUILDING, 4M WEST OF PROFILE

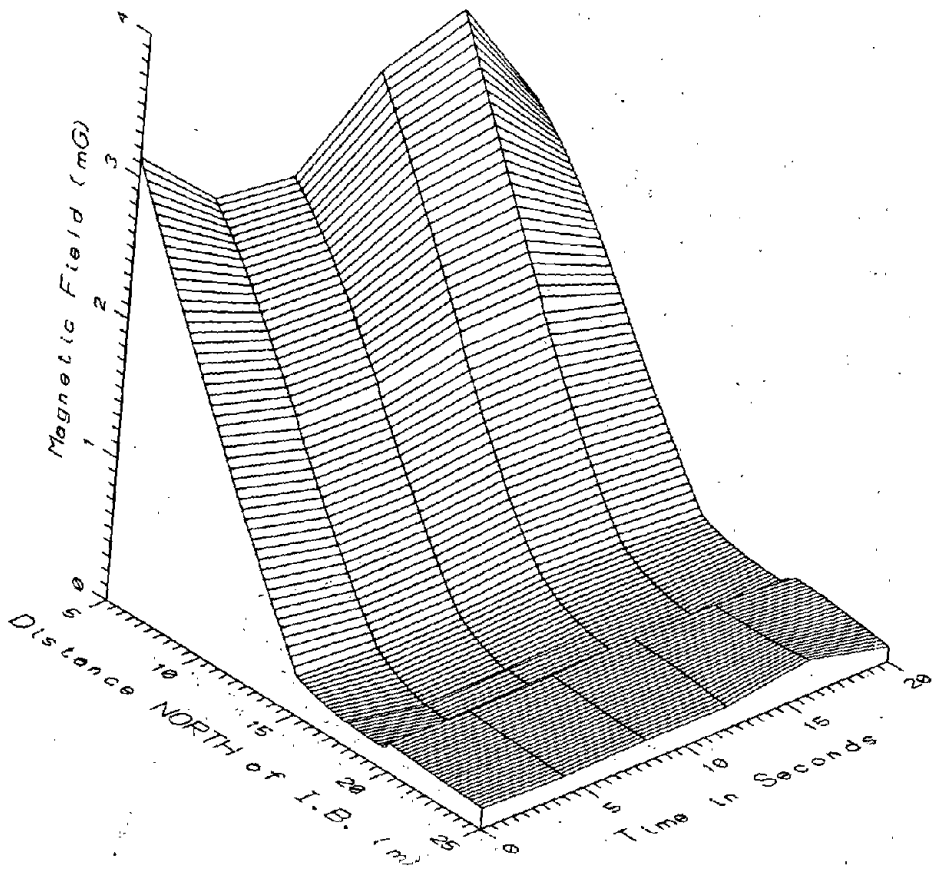

TR7028, INVERTER BUILDING - LOW FREQUENCY, 5-45Hz

W-7

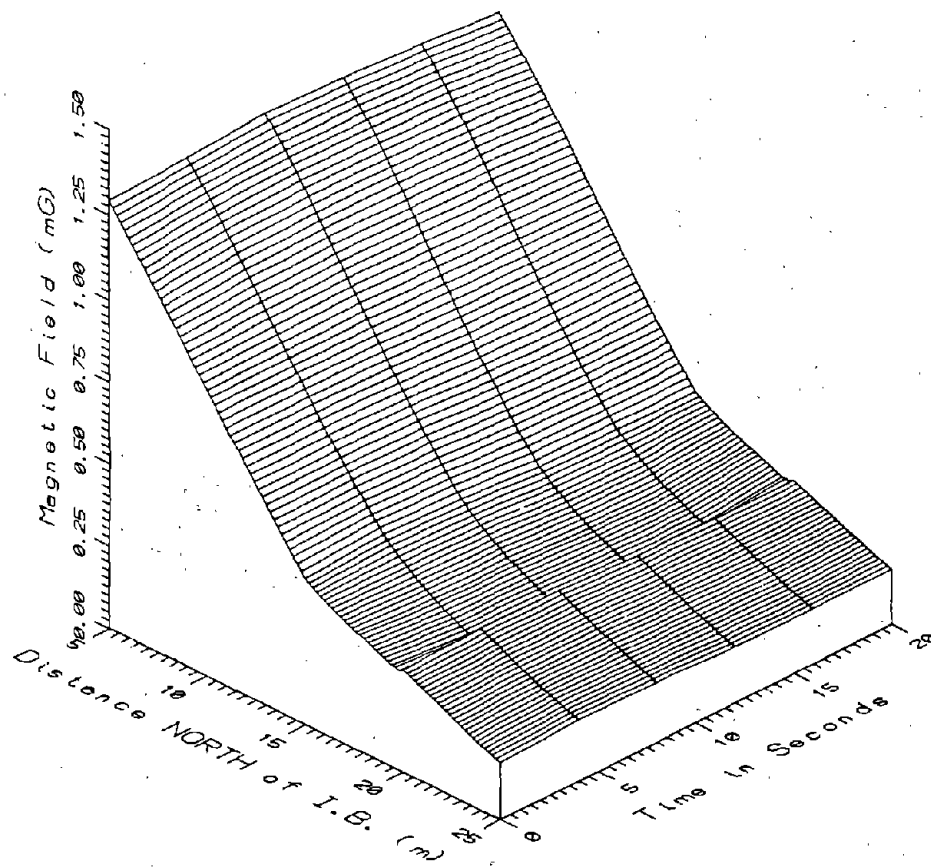

TR7028, INVERTER BUILDING - POWER FREQUENCY, 50-60Hz.

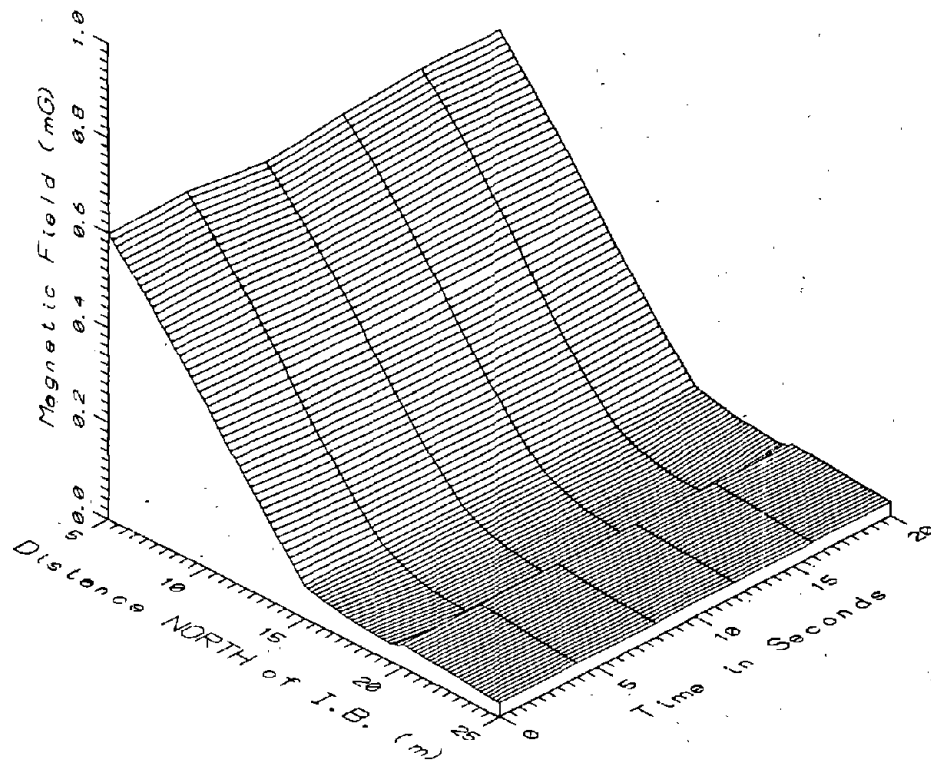

TR7028, INVERTER BUILDING - POWER HARMONICS, 65-300Hz

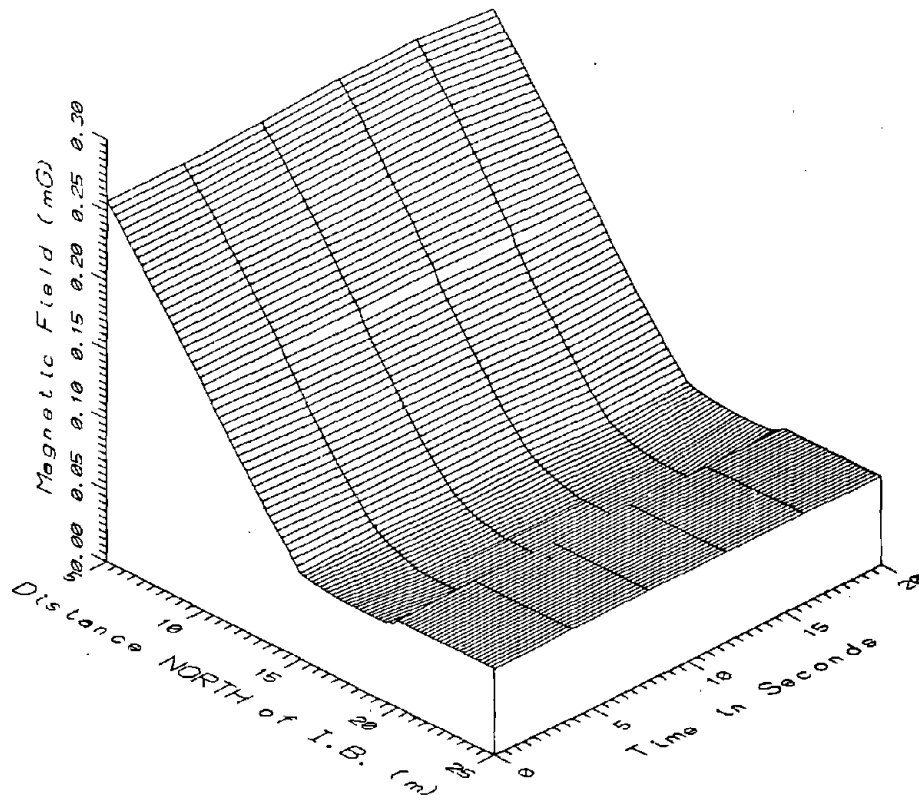

TR7028, INVERTER BUILDING - HIGH FREQUENCY, 305-2560Hz

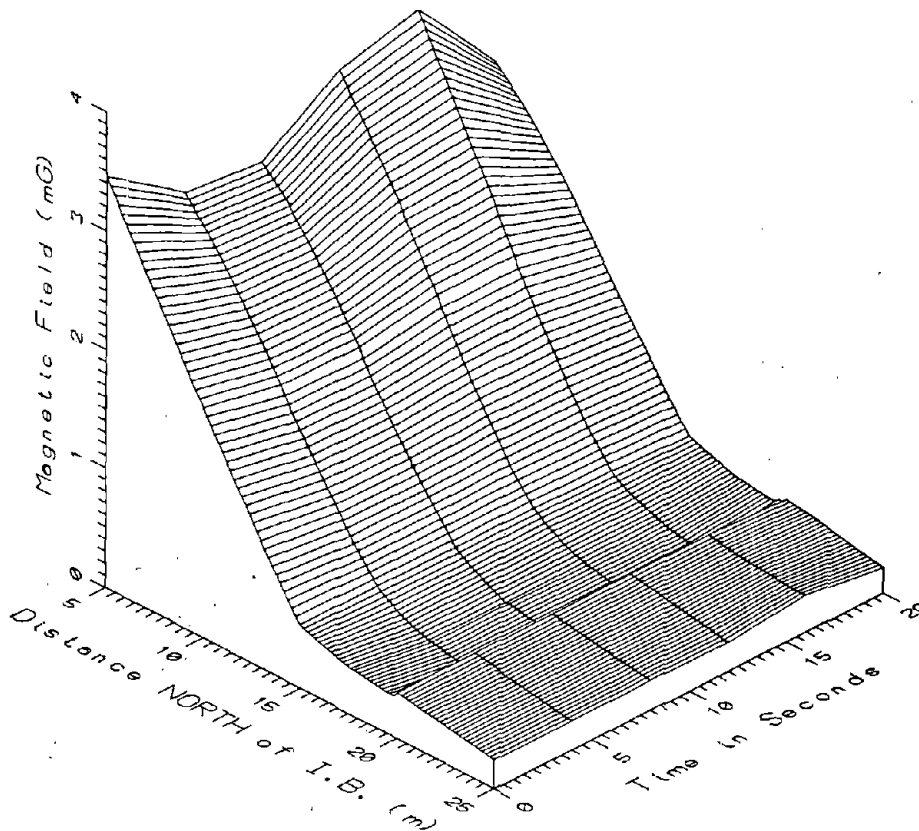

TR7028, INVERTER BUILDING - ALL FREQUENCIES, 5-2560Hz

w-9

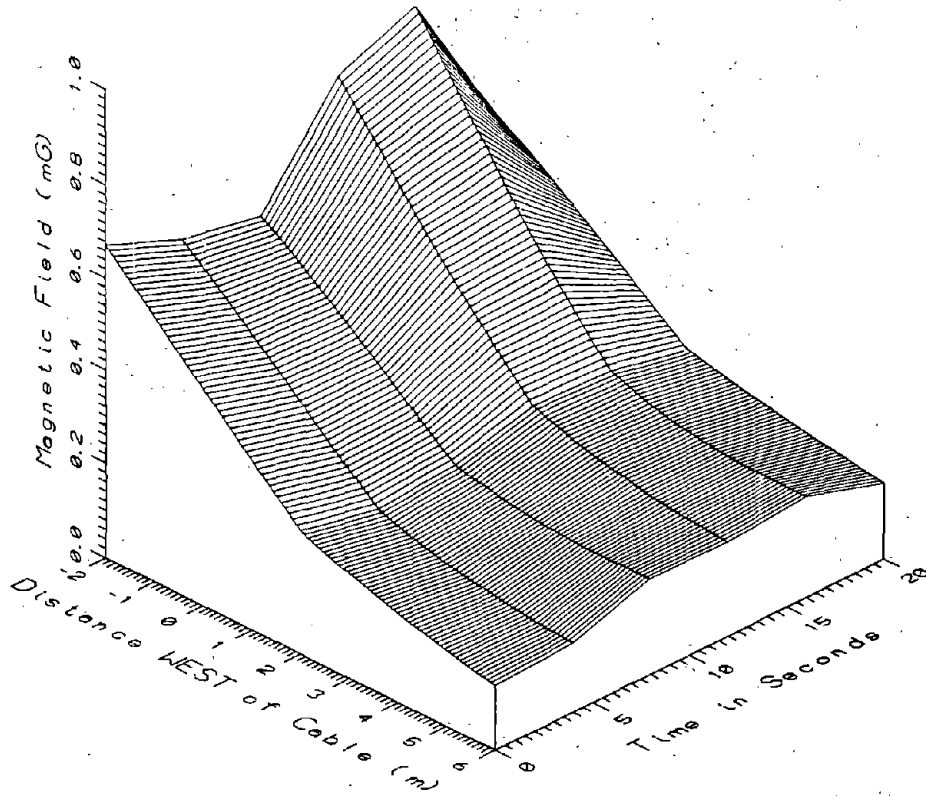

TR7028, BURIED CABLE FEEDING INVERTER BUILDING - LOW FREQUENCY, 5-45Hz

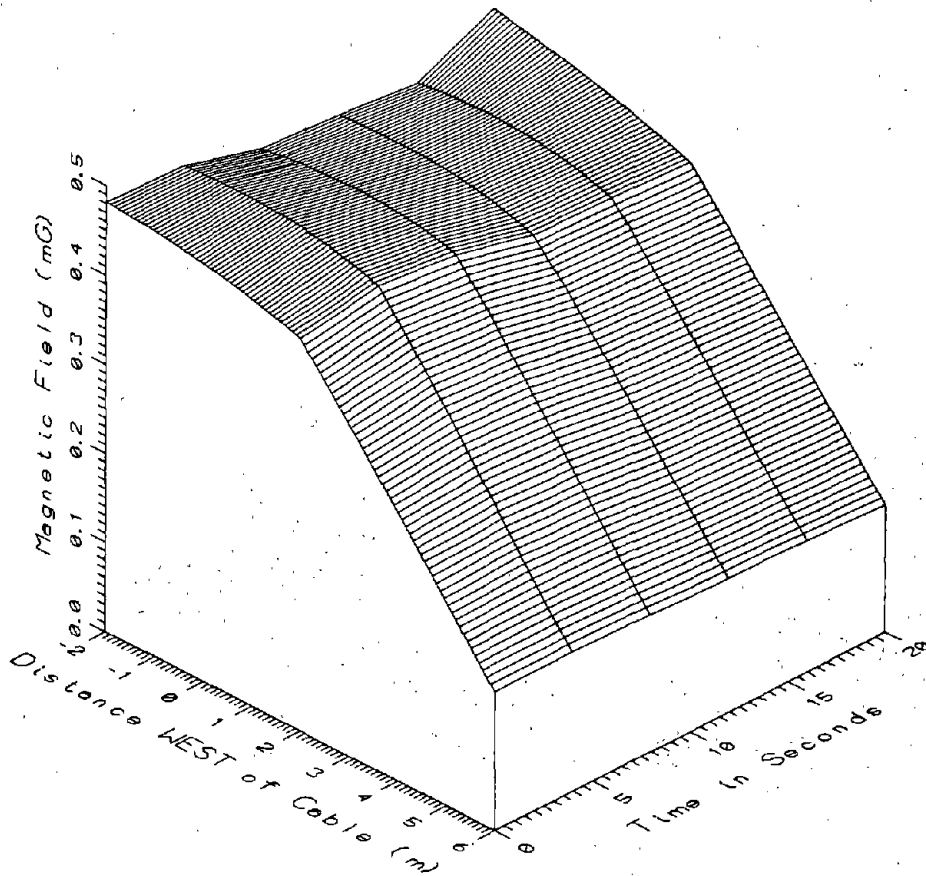

TR7028, BURIED CABLE FEEDING INVERTER BUILDING - POWER FREQUENCY, 50-60Hz

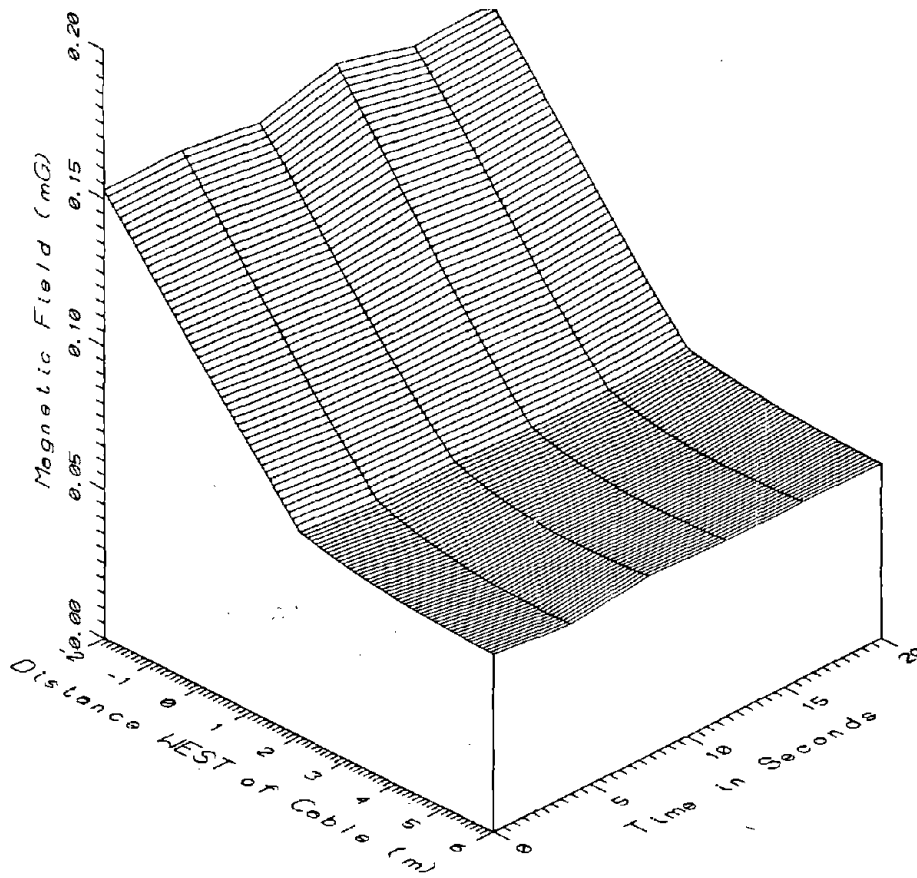

TR7028. BURIED CABLE FEEDING INVERTER BUILDING - POWER HARMONICS, 65-300Hz

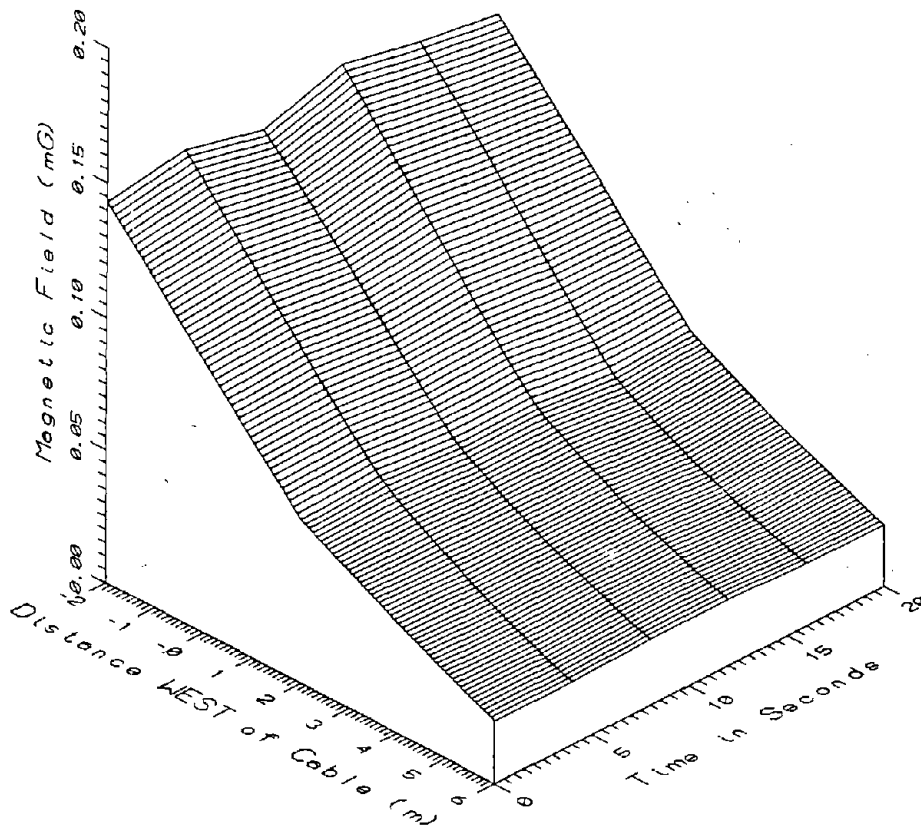

TR7028. BURIED CABLE FEEDING INVERTER BUILDING - HIGH FREQUENCY, 305-2560Hz

W-12

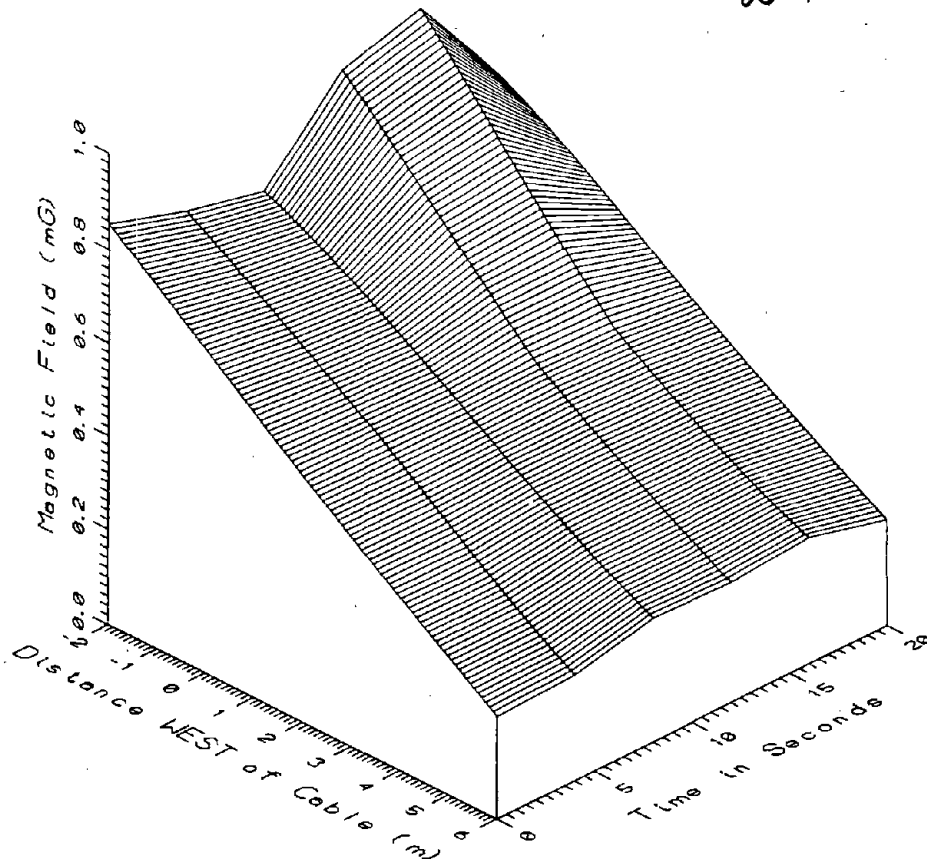

TR7028. BURIED CABLE FEEDING INVERTER BUILDING - ALL FREQUENCIES, 5-2560Hz



APPENDIX X

DATA SET TR7030

**MEASUREMENTS NEAR THE
INVERTER BUILDING AND FEEDER CABLES**

X-11

APPENDIX X

DATA SET TR7030
MEASUREMENTS NEAR THE
INVERTER BUILDING AND FEEDER CABLES

Measurement Setup Code: 26
Vehicle Status: Running continuously
Measurement Date: August 10, 1990
Measurement Time: Start: 12:07:30
End: 12:27:38
Number of Samples: 219
Programmed Sample Interval: 4 sec
Actual Sample Interval: 5.5 sec

Frequency Spectrum Parameters

<u>Probe Type:</u>	<u>Coil (AC)</u>	<u>Fluxgate (DC)</u>
Maximum Frequency (Hz)	2560	256
Minimum Frequency (Hz)	5	0
Spectral Bandwidth (Hz)	5	0.5

Missing or Suspect Data: The fluxgate sensor 15 m north of the inverter building and 2 m west of the feeder cable was inoperative.

SETUP 25 AND 26: OUTSIDE INVERTER BUILDING ALONG MAIN FEEDER CABLES

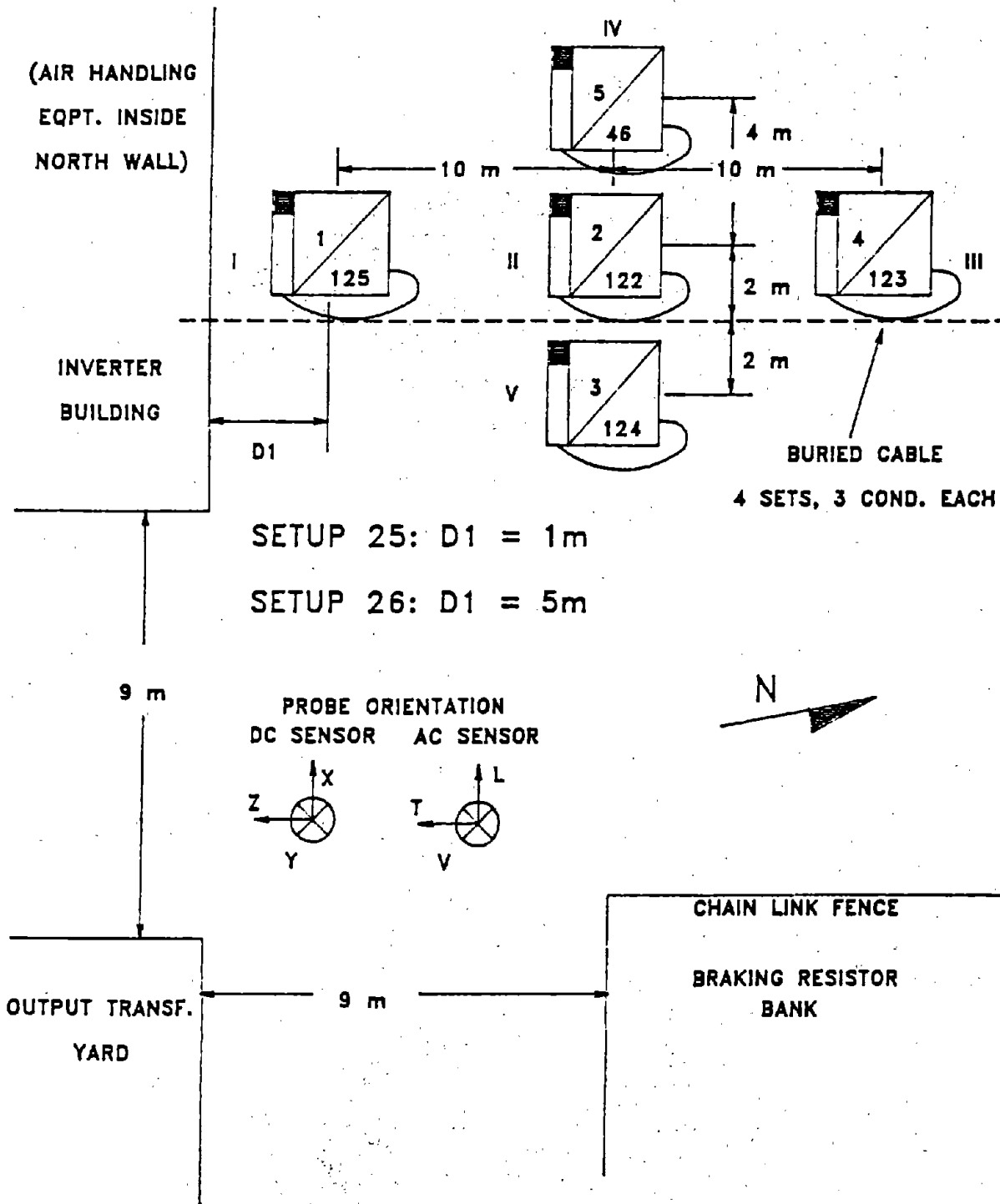

X-2

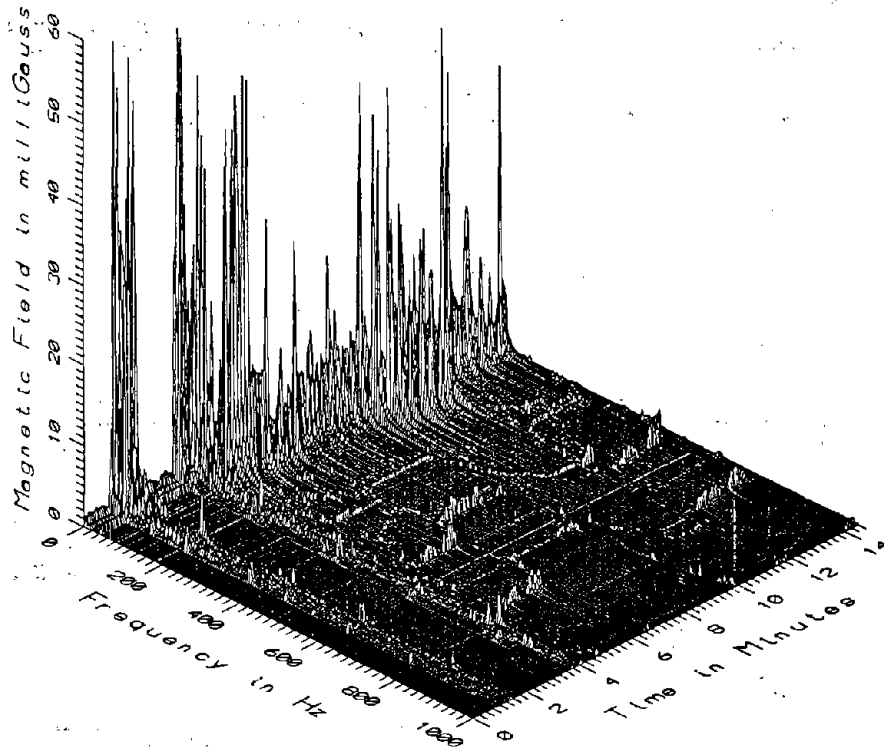

TR7030 - 5M NORTH OF INVERTER BUILDING

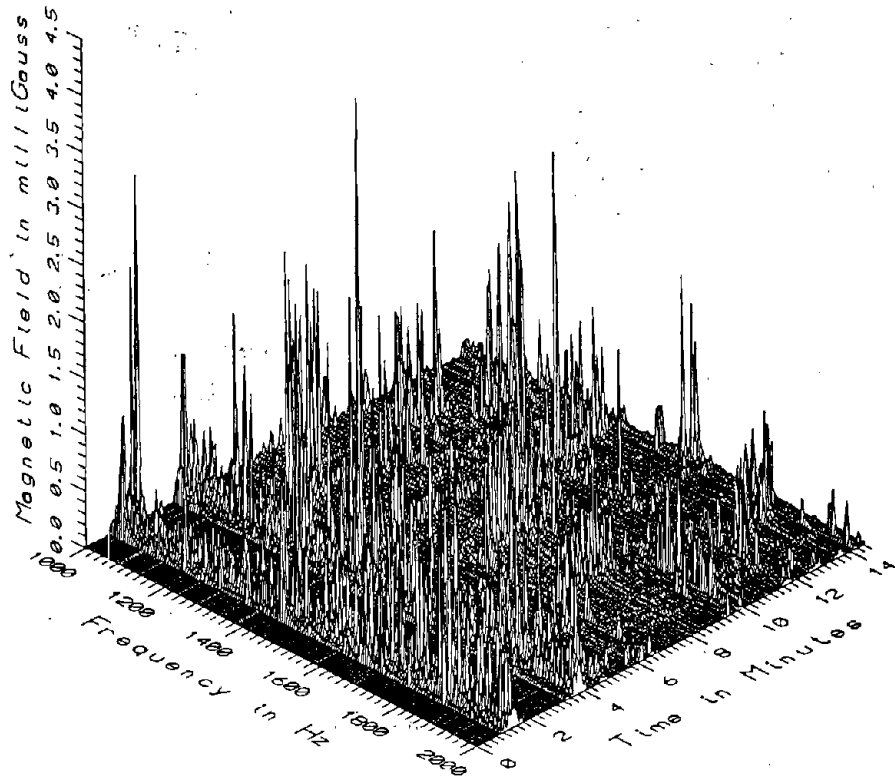

TR7030 - 5M NORTH OF INVERTER BUILDING

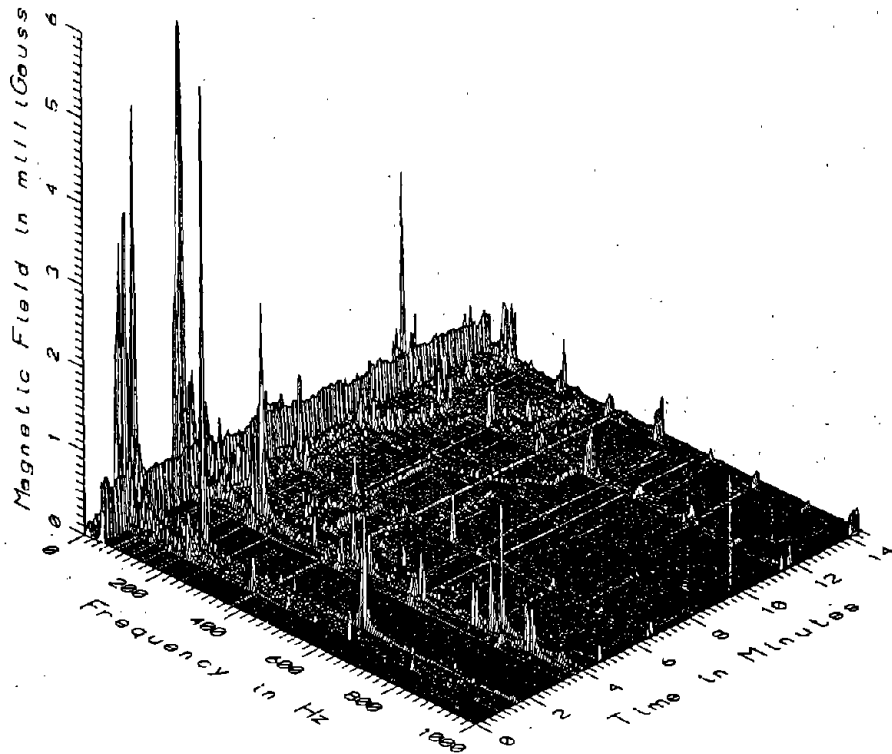

TR7030 - 15M NORTH OF INVERTER BUILDING

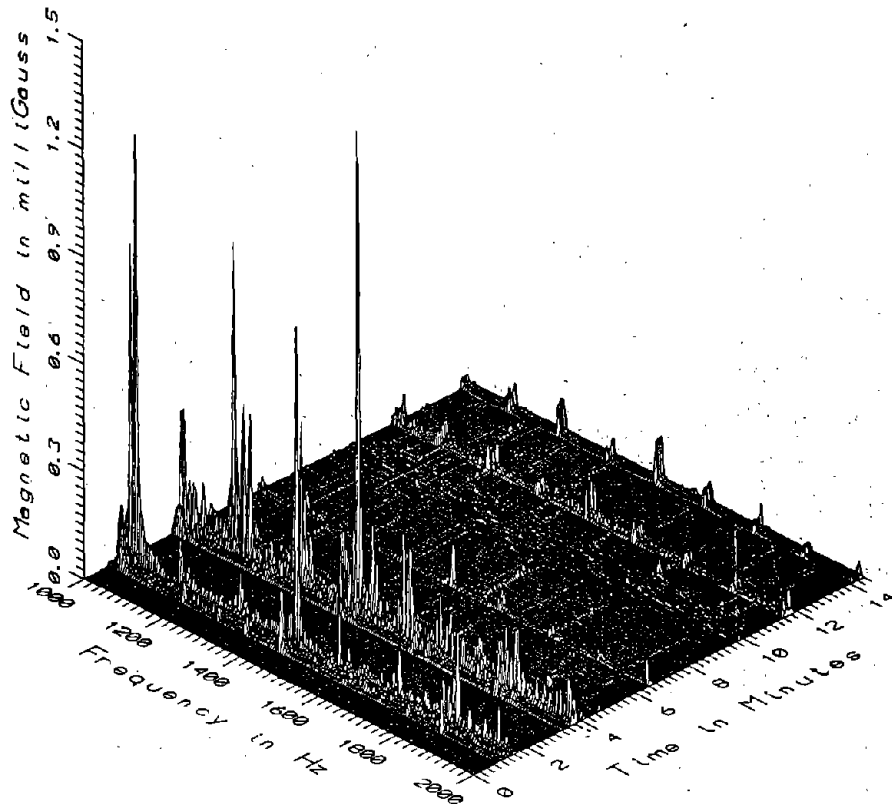

TR7030 - 15M NORTH OF INVERTER BUILDING

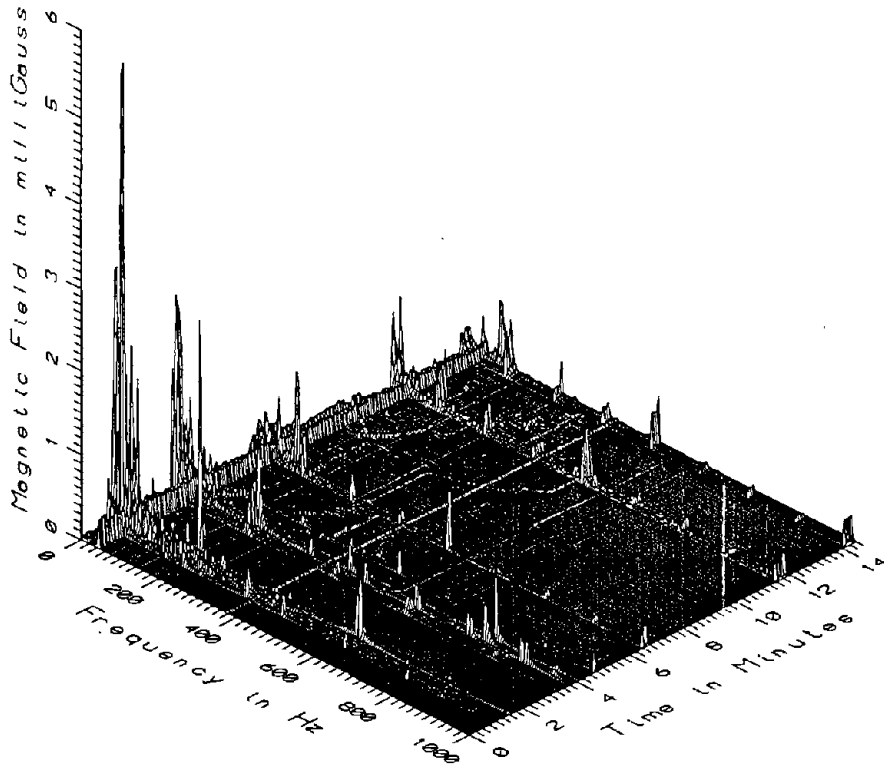

TR7030 - 25M NORTH OF INVERTER BUILDING

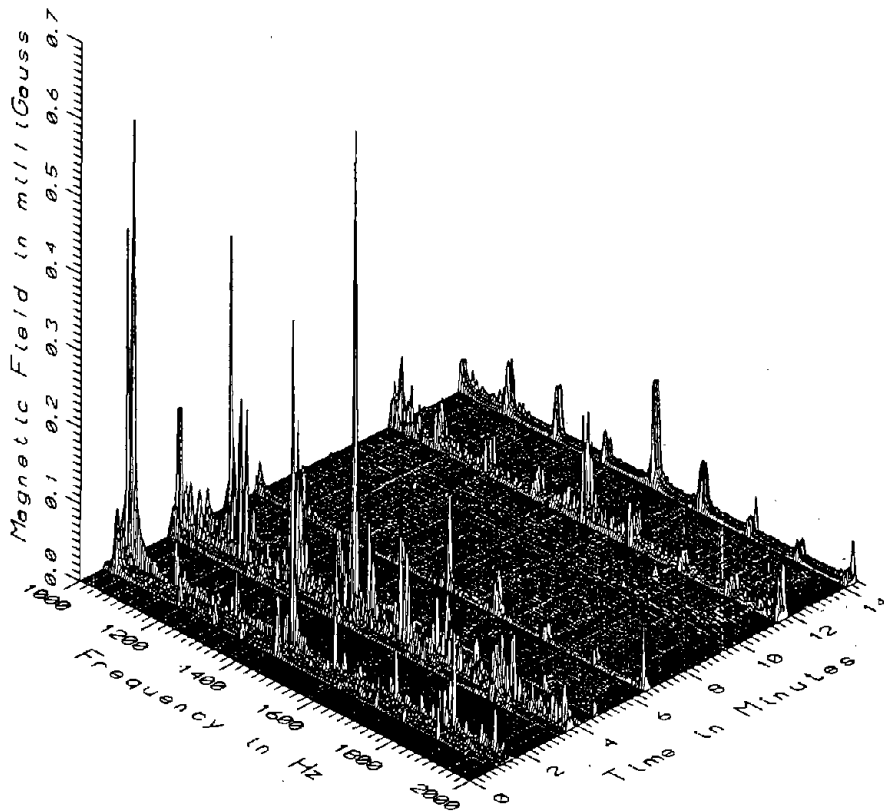

TR7030 - 25M NORTH OF INVERTER BUILDING

X-5

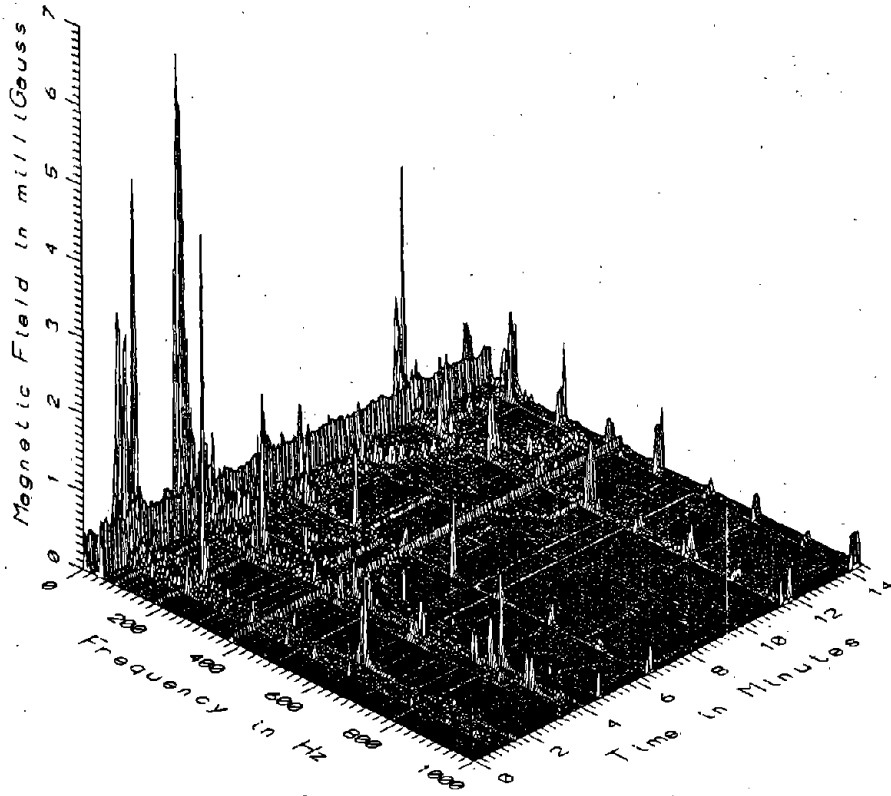

TR7030 - 15M NORTH OF INVERTER BUILDING, 4M EAST OF PROFILE

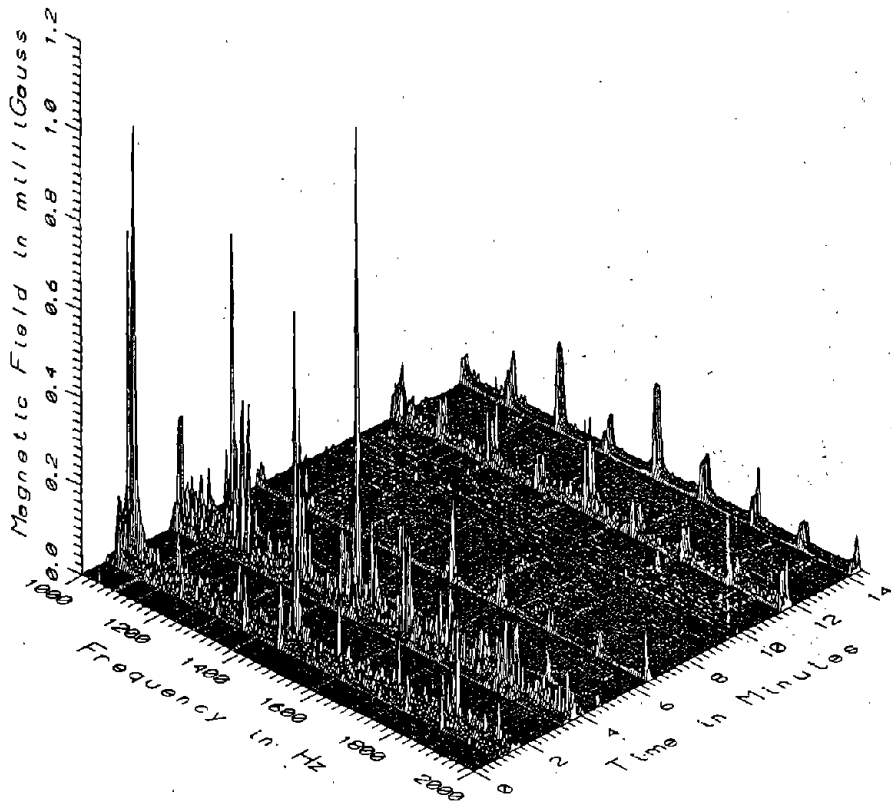

TR7030 - 15M NORTH OF INVERTER BUILDING, 4M EAST OF PROFILE

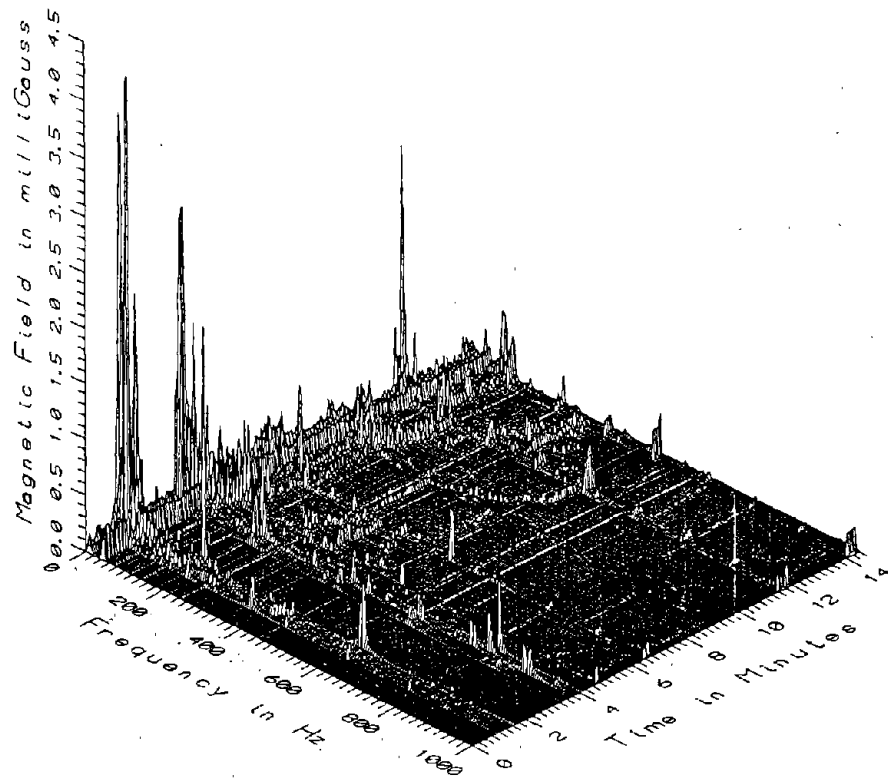

TR7030 - 15M NORTH OF INVERTER BUILDING, 4M WEST OF PROFILE

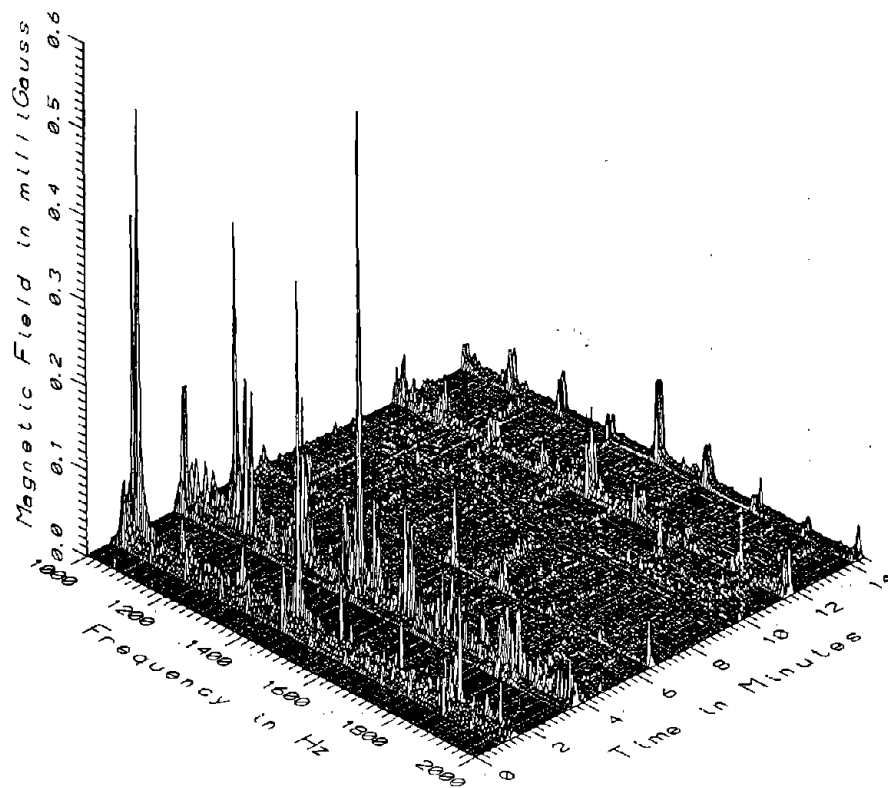

TR7030 - 15M NORTH OF INVERTER BUILDING, 4M WEST OF PROFILE

X-7

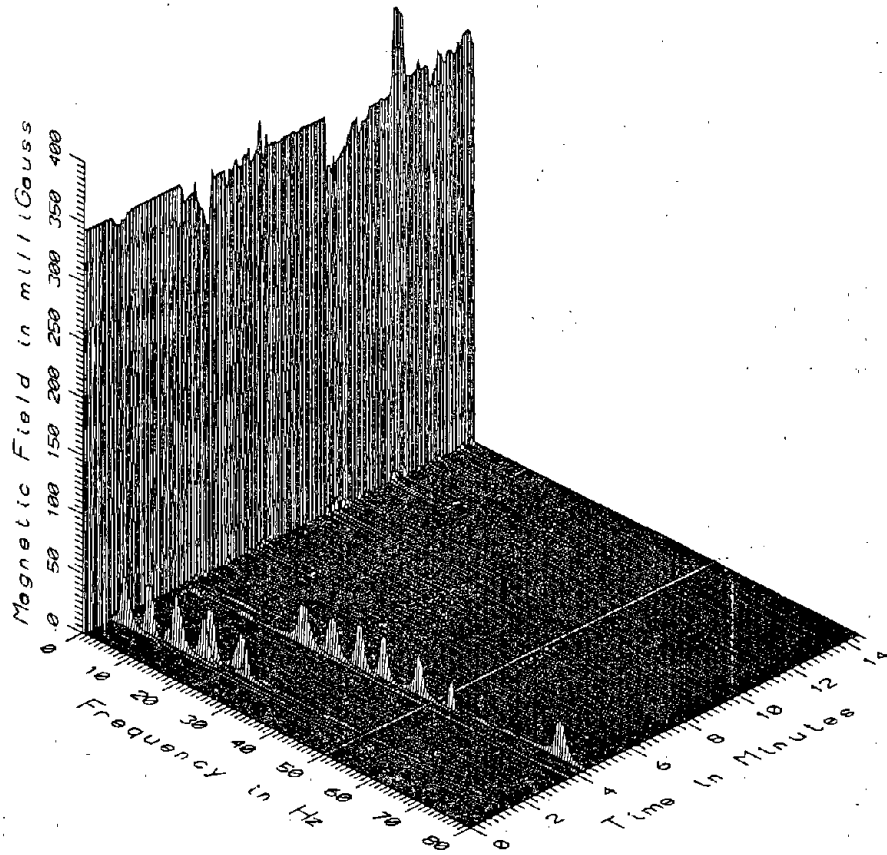

TR7030 - 5M NORTH OF INVERTER BUILDING

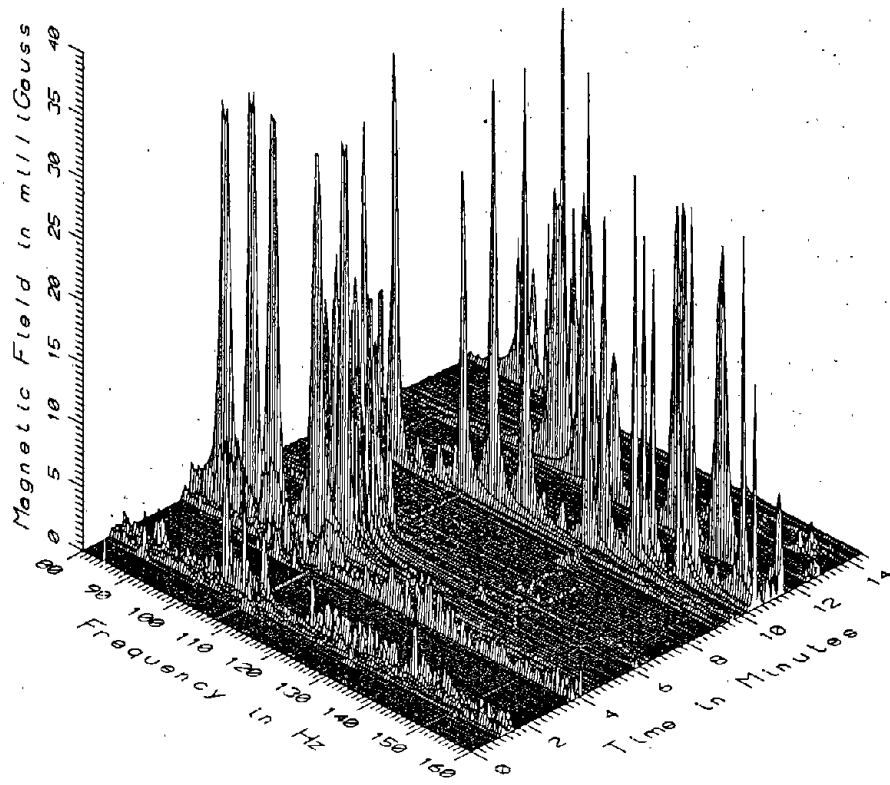

TR7030 - 5M NORTH OF INVERTER BUILDING

X-8

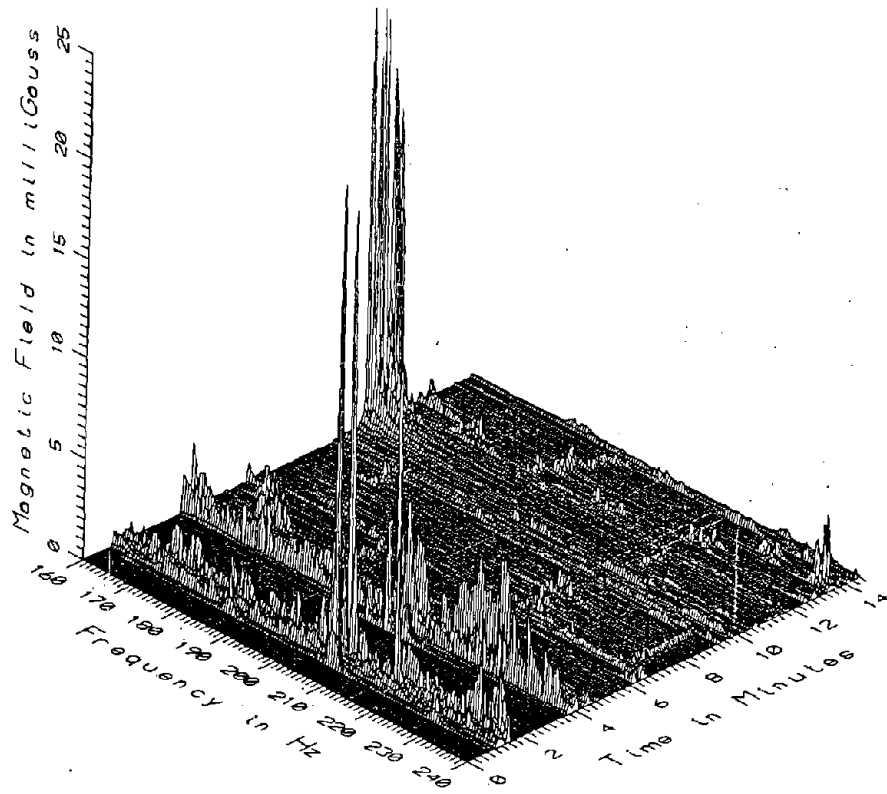

TR7030 - 5M NORTH OF INVERTER BUILDING

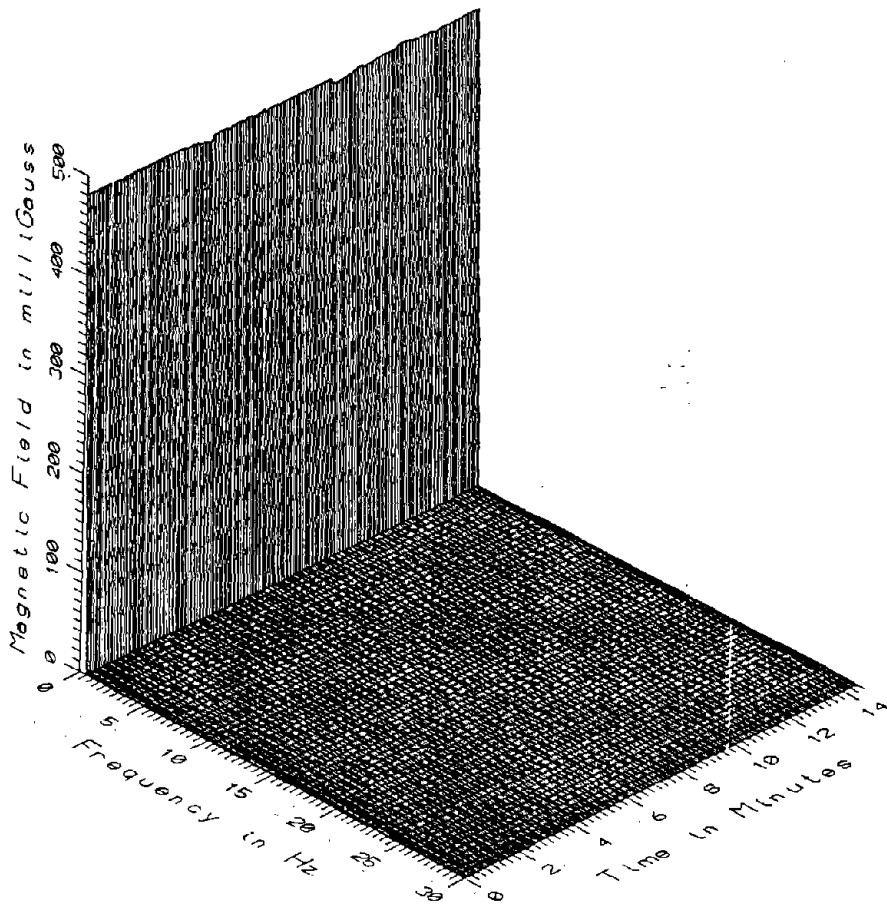

TR7030 - 25M NORTH OF INVERTER BUILDING

X-9

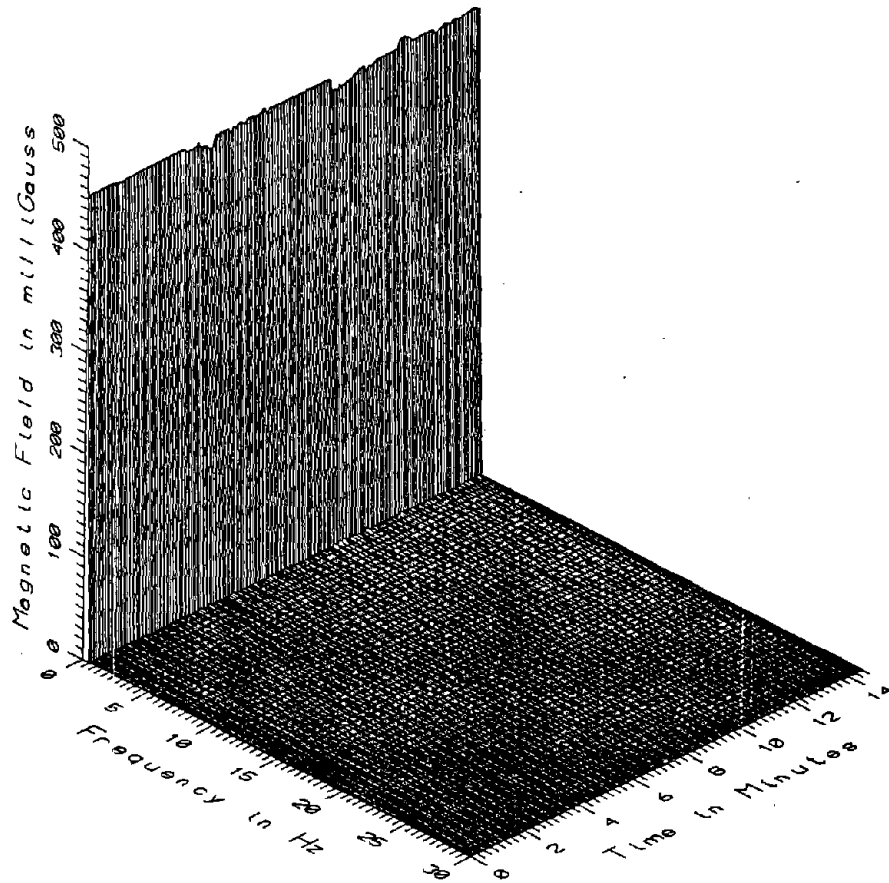

TR7030 - 15M NORTH OF INVERTER BUILDING, 4M EAST OF PROFILE

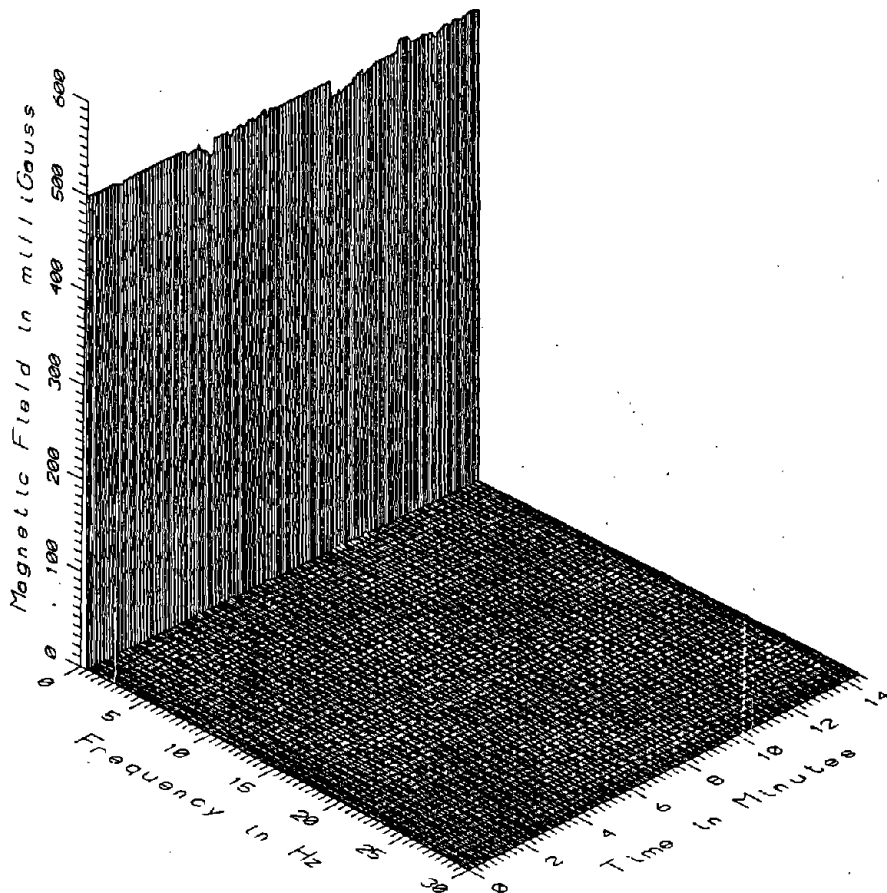

TR7030 - 15M NORTH OF INVERTER BUILDING, 4M WEST OF PROFILE

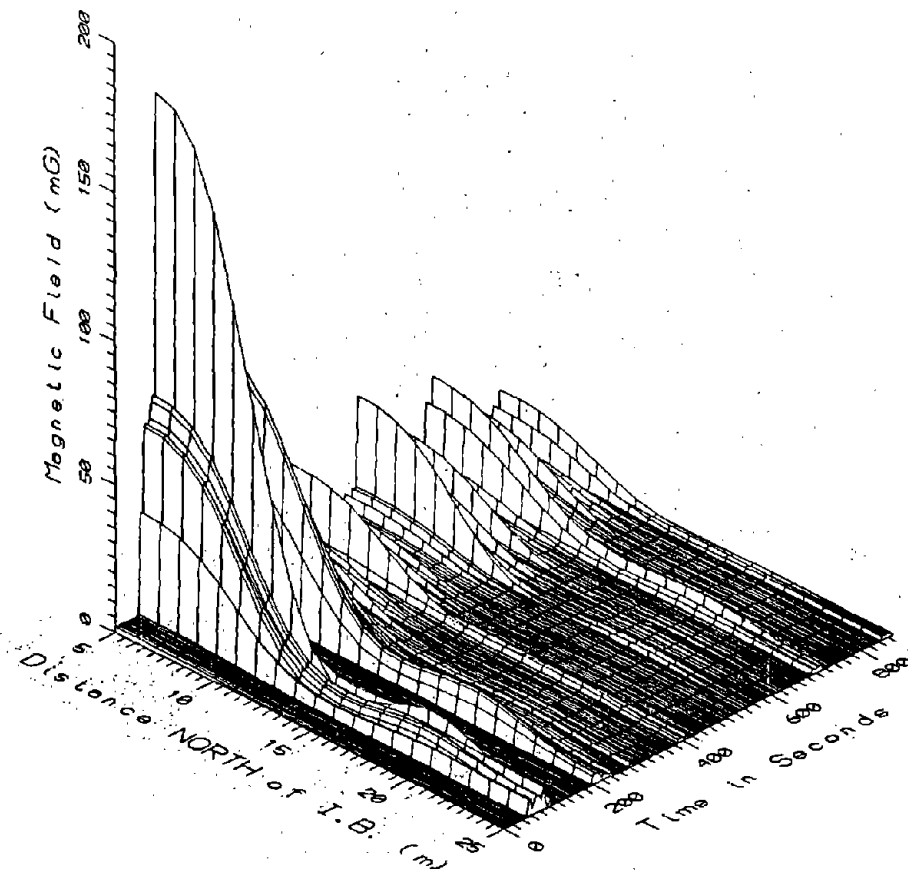

TR7030. INVERTER BUILDING - LOW FREQUENCY, 5-45Hz

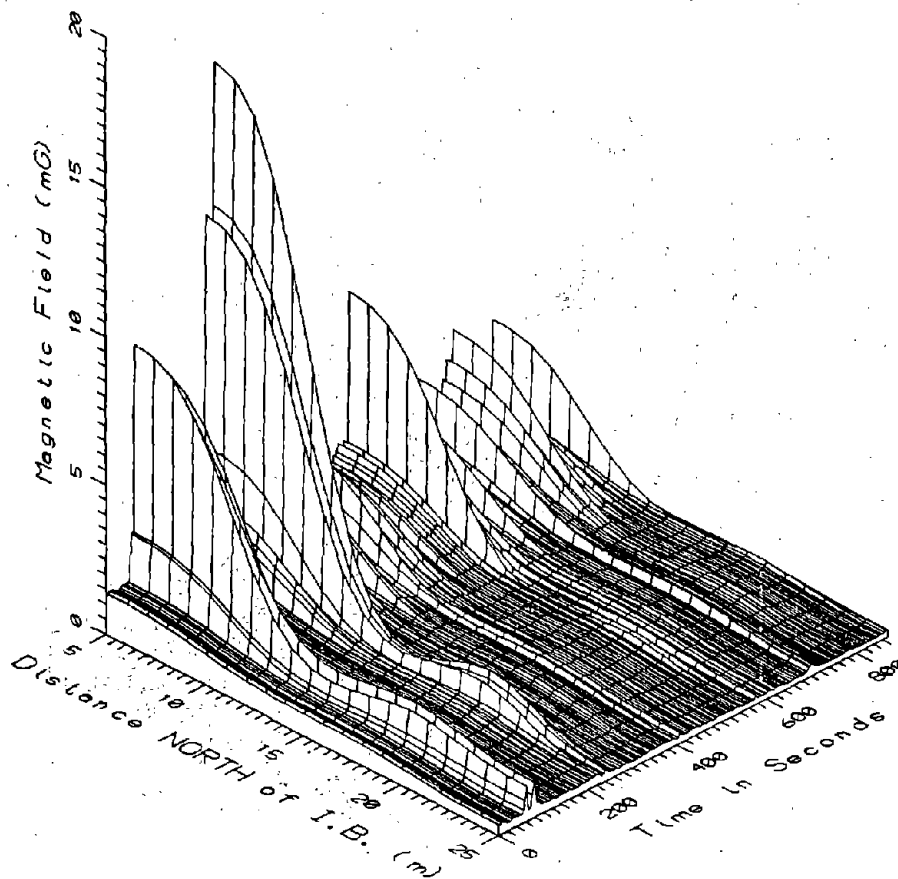

TR7030, INVERTER BUILDING - POWER FREQUENCY, 50-60Hz

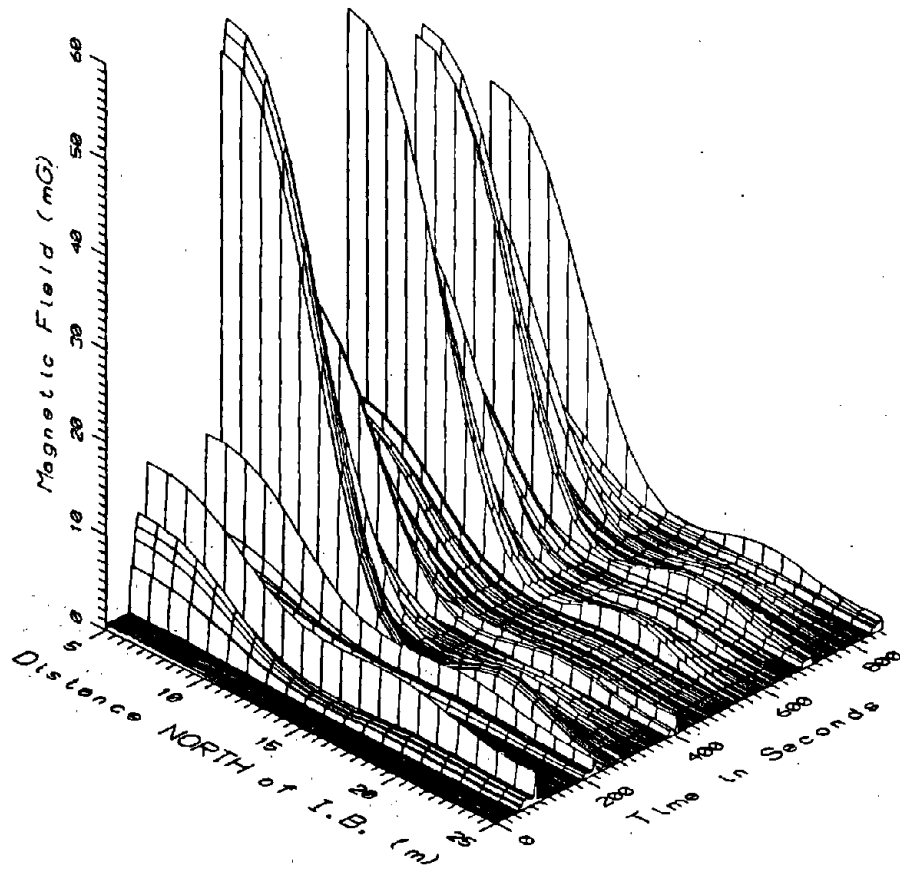

TR7030, INVERTER BUILDING - POWER HARMONICS, 65-300Hz

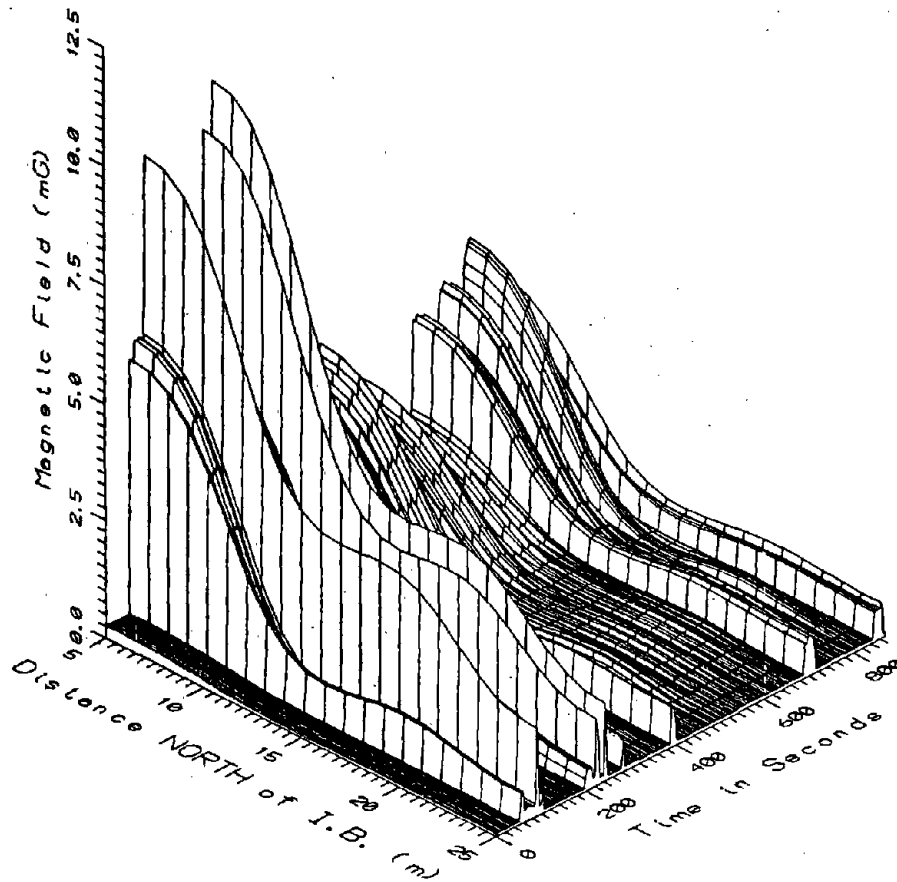

TR7030, INVERTER BUILDING - HIGH FREQUENCY, 305-2560Hz

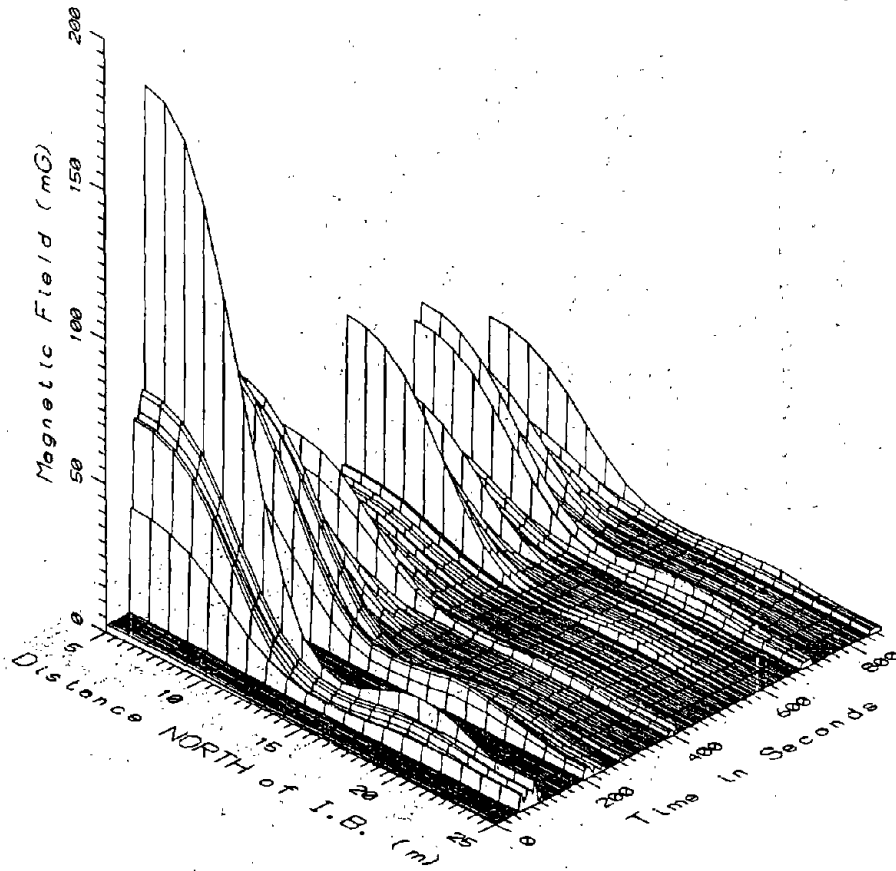

TR7030, INVERTER BUILDING - ALL FREQUENCIES, 5-2560Hz

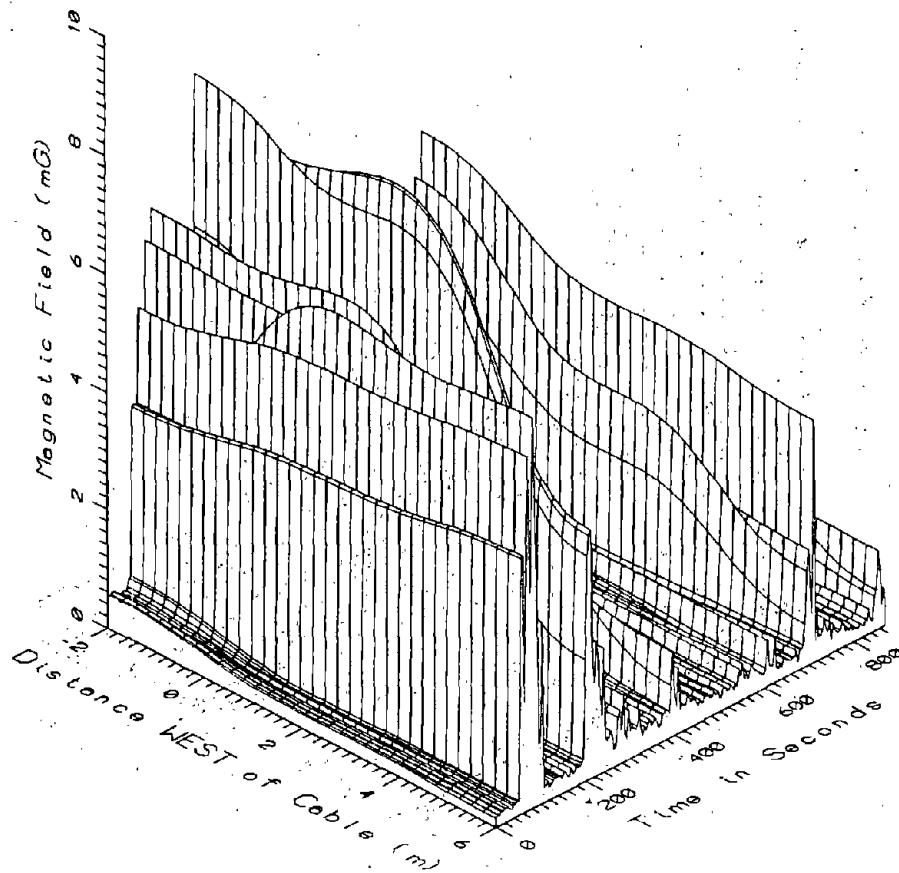

TR7030, BURIED CABLE FEEDING INVERTER BUILDING - LOW FREQUENCY, 5-45Hz

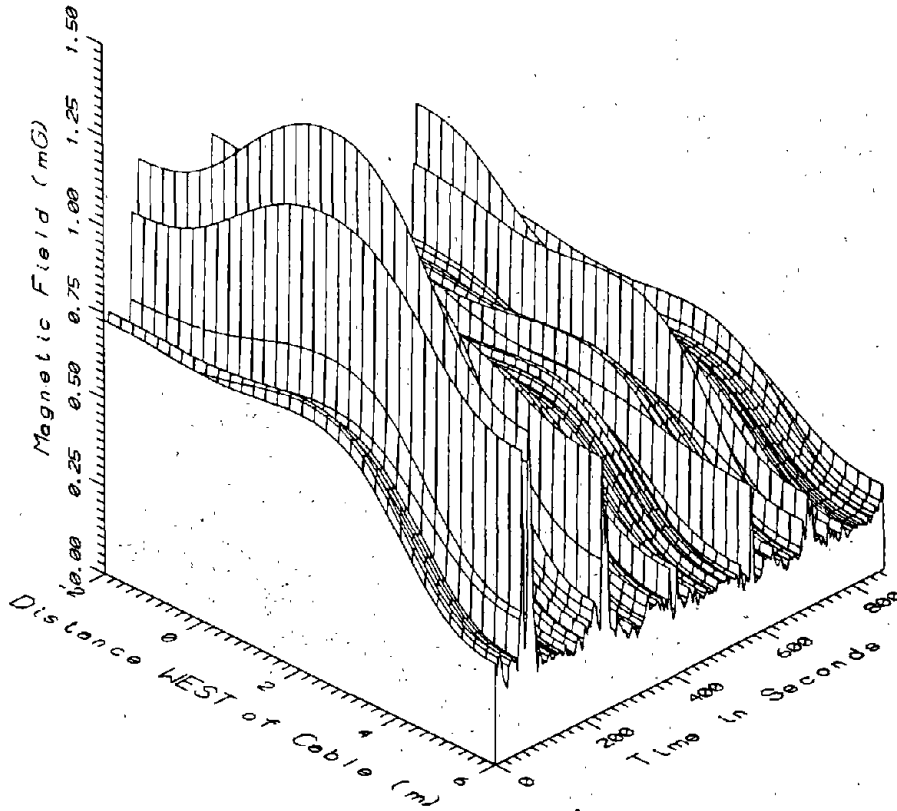

TR7030. BURIED CABLE FEEDING INVERTER BUILDING - POWER FREQUENCY, 50-60Hz

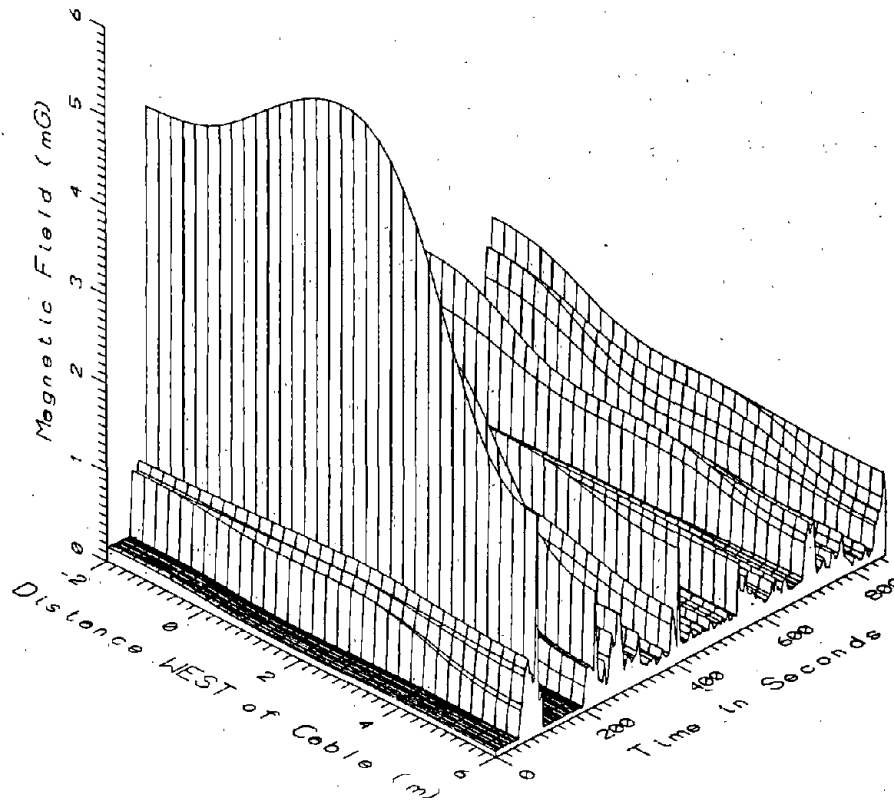

TR7030. BURIED CABLE FEEDING INVERTER BUILDING - POWER HARMONICS, 65-300Hz

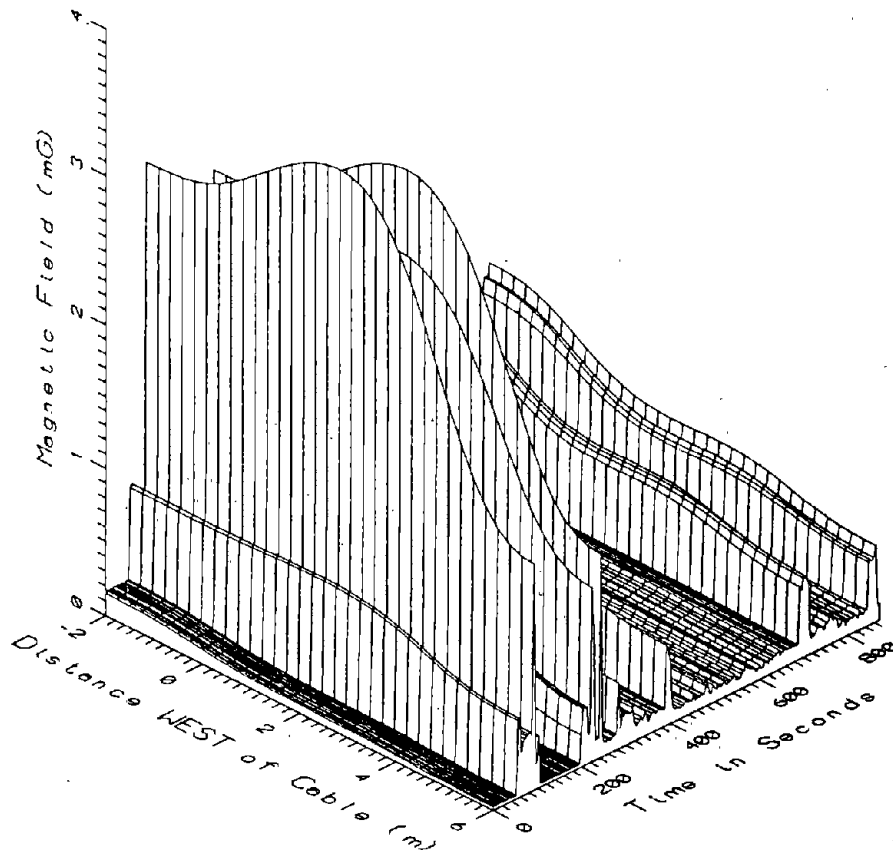

TR7030, BURIED CABLE FEEDING INVERTER BUILDING - HIGH FREQUENCY, 305-2560Hz

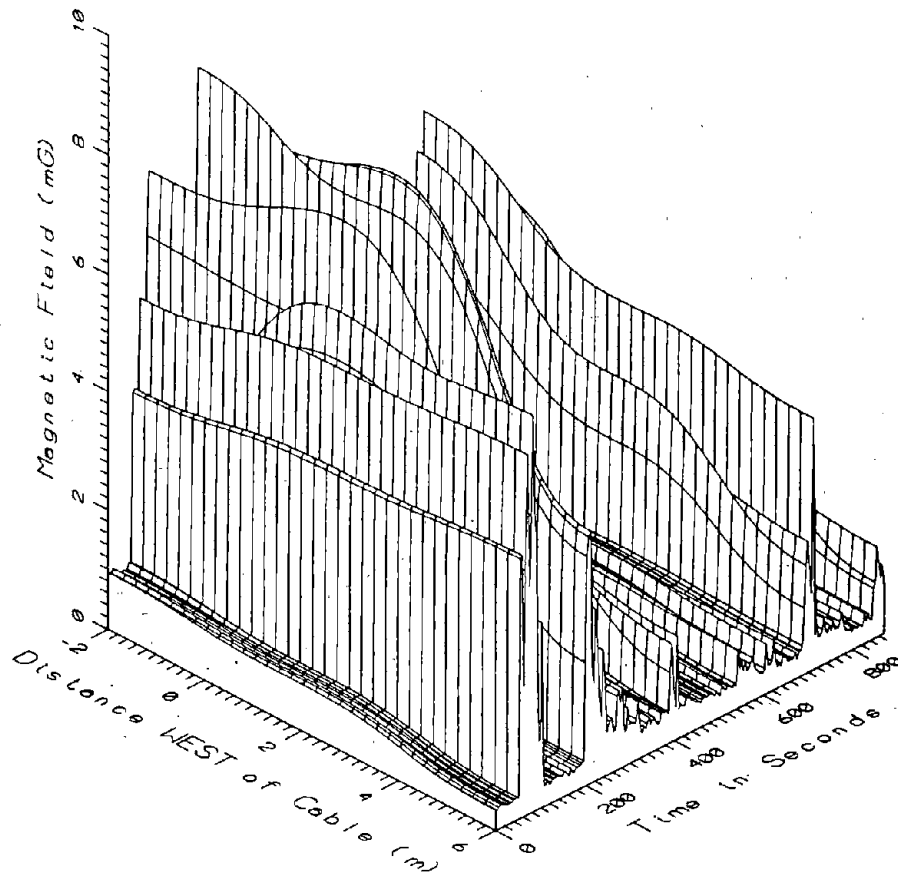

TR7030, BURIED CABLE FEEDING INVERTER BUILDING - ALL FREQUENCIES, 5-2560Hz

Y-1

APPENDIX Y

DATA SET TR7031

**LATERAL PROFILE ABOVE A FEEDER CABLE
(GROUND LEVEL)**

4-1

APPENDIX Y

DATA SET TR7031
LATERAL PROFILE ABOVE A FEEDER CABLE (GROUND LEVEL)

Measurement Setup Code: 27
Vehicle Status: Parked in maintenance facility
Measurement Date: August 10, 1990
Measurement Time: Start: 13:04:00
End: 13:05:00
Number of Samples: 6
Programmed Sample Interval: 4 sec
Actual Sample Interval: 6 sec

Frequency Spectrum Parameters

<u>Probe Type:</u>	<u>Coil (AC)</u>	<u>Fluxgate (DC)</u>
Maximum Frequency (Hz)	2560	256
Minimum Frequency (Hz)	5	0
Spectral Bandwidth (Hz)	5	0.5

Missing or Suspect Data: The fluxgate sensor 1 m east of the guideway centerline and 2.5 m west of the feeder cable location was inoperative.

SETUP 27 AND 28: FEEDER CABLE

TOP VIEW

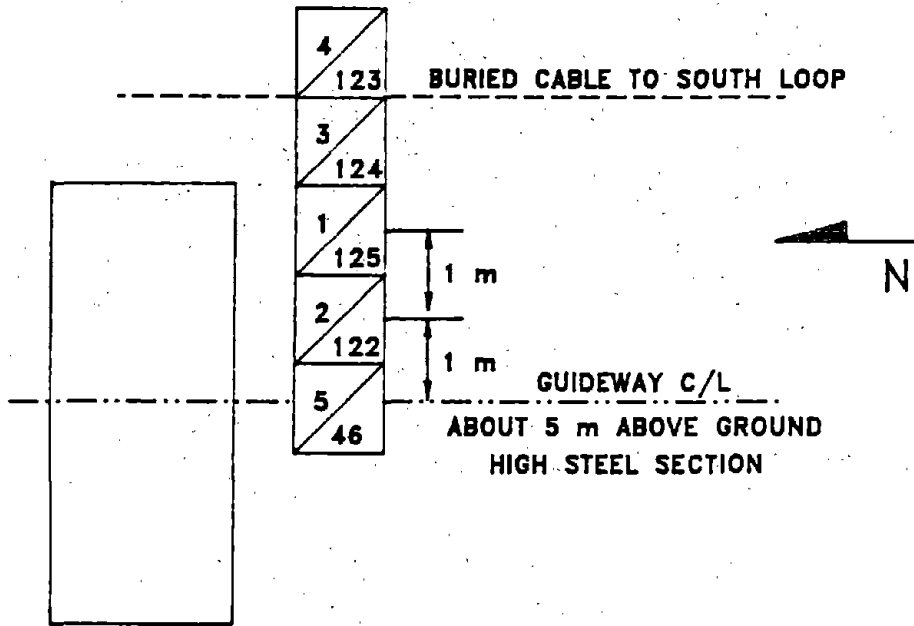

SIDE VIEW

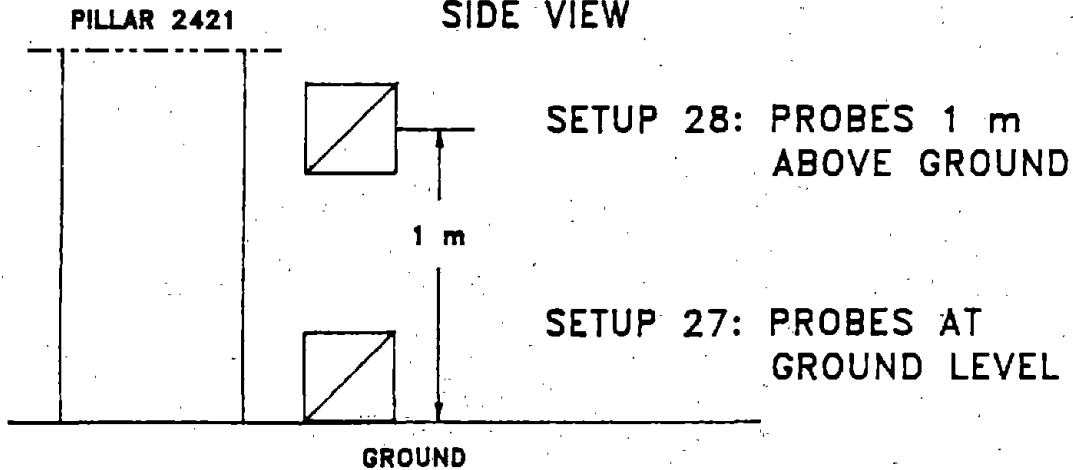

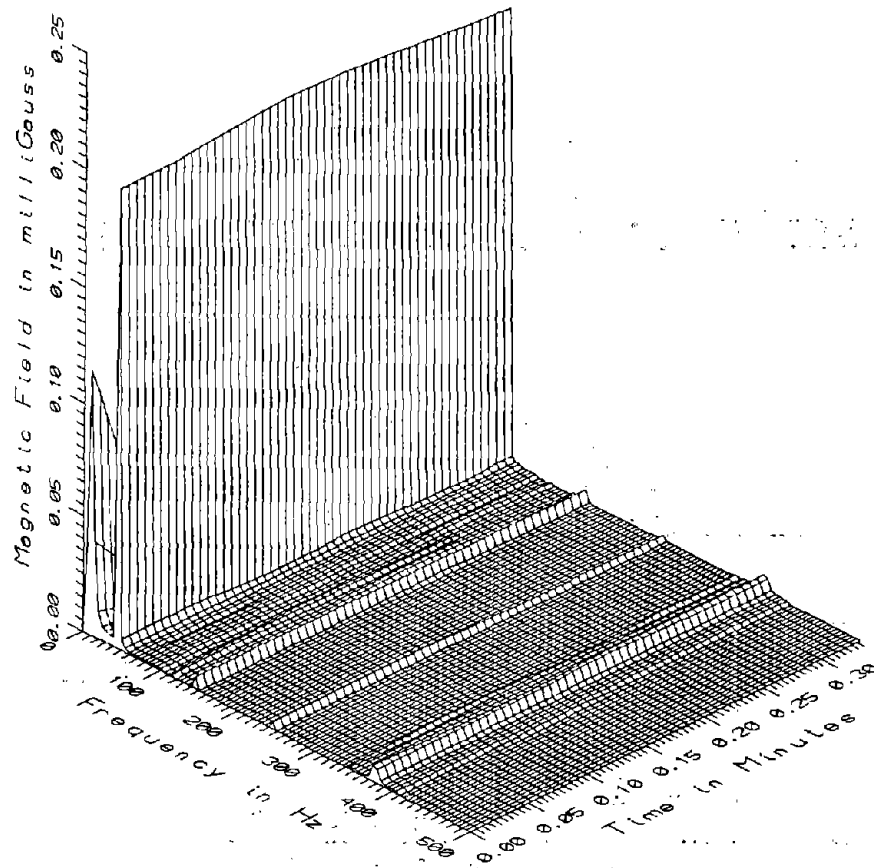

TR7031 - 0.5M EAST OF SOUTH LOOP FEEDER CABLE, GROUND LEVEL

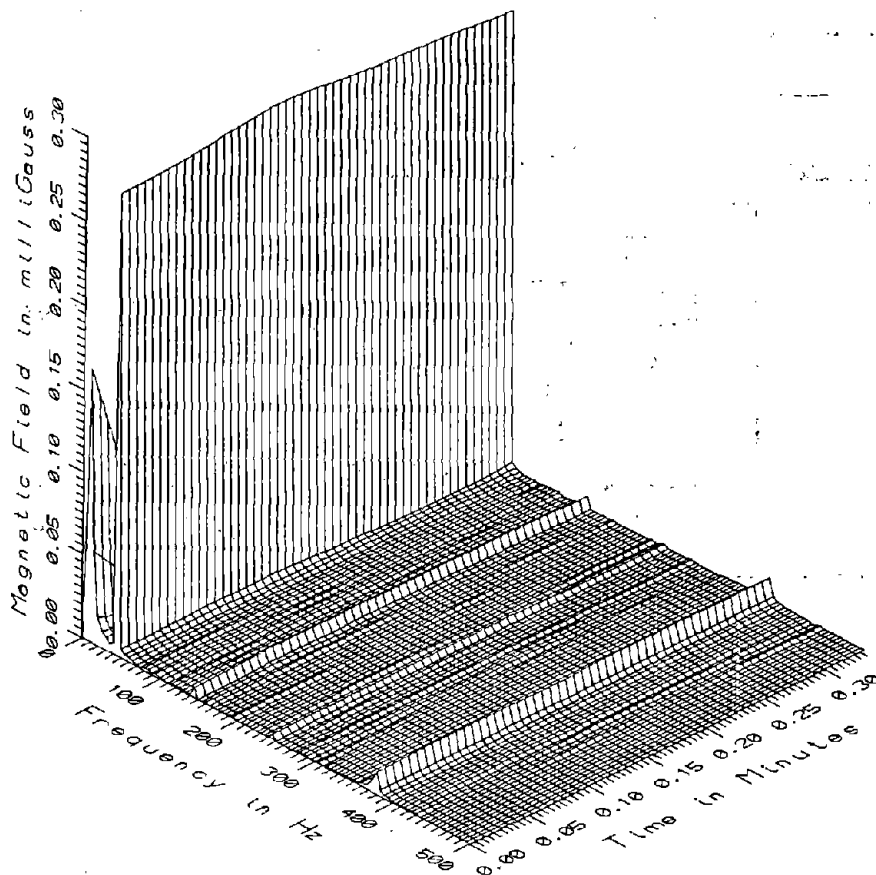

TR7031 - 0.5M WEST OF SOUTH LOOP FEEDER CABLE, GROUND LEVEL

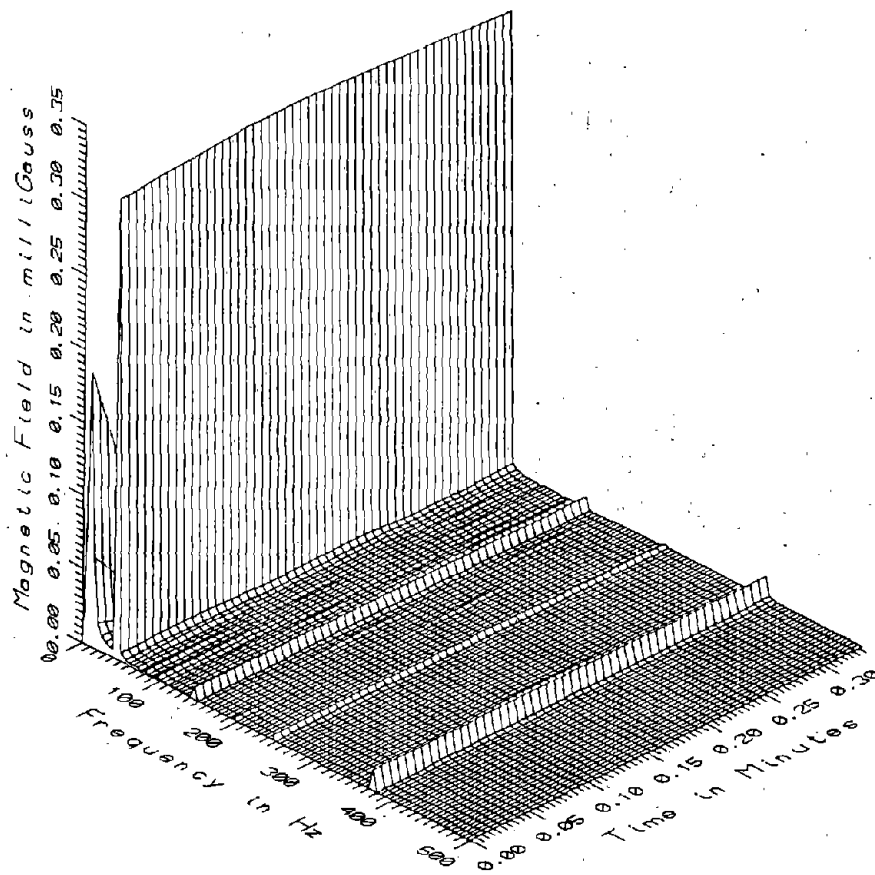

TR7031 - 1.5M WEST OF SOUTH LOOP FEEDER CABLE, GROUND LEVEL

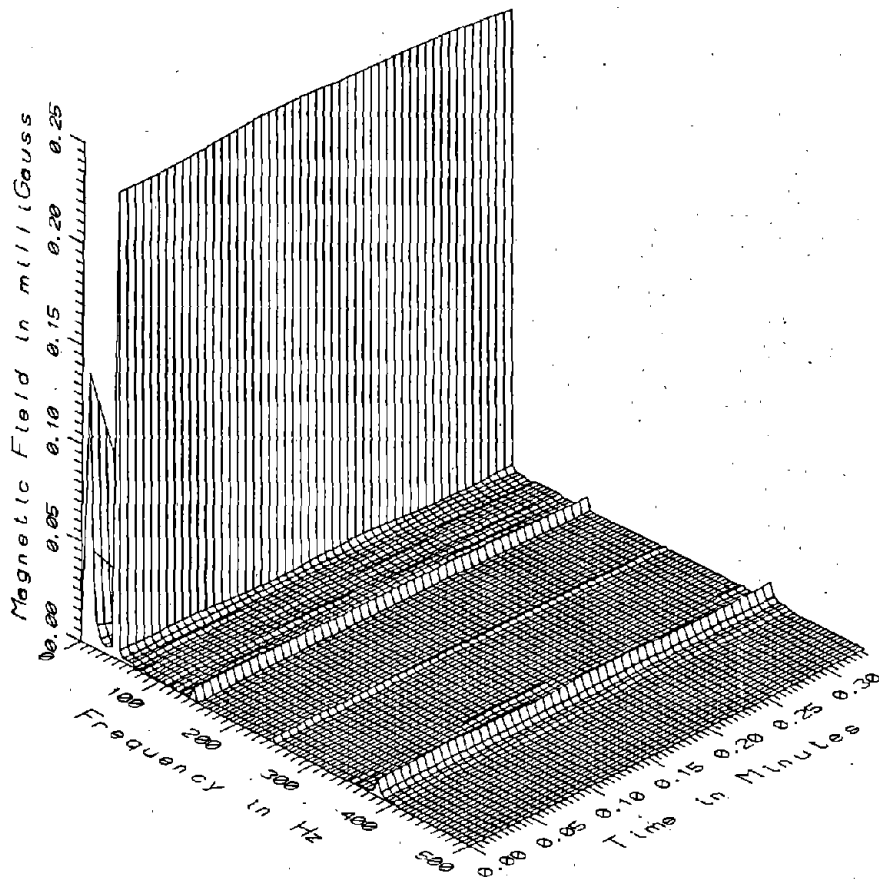

TR7031 - 2.5M WEST OF SOUTH LOOP FEEDER CABLE, GROUND LEVEL

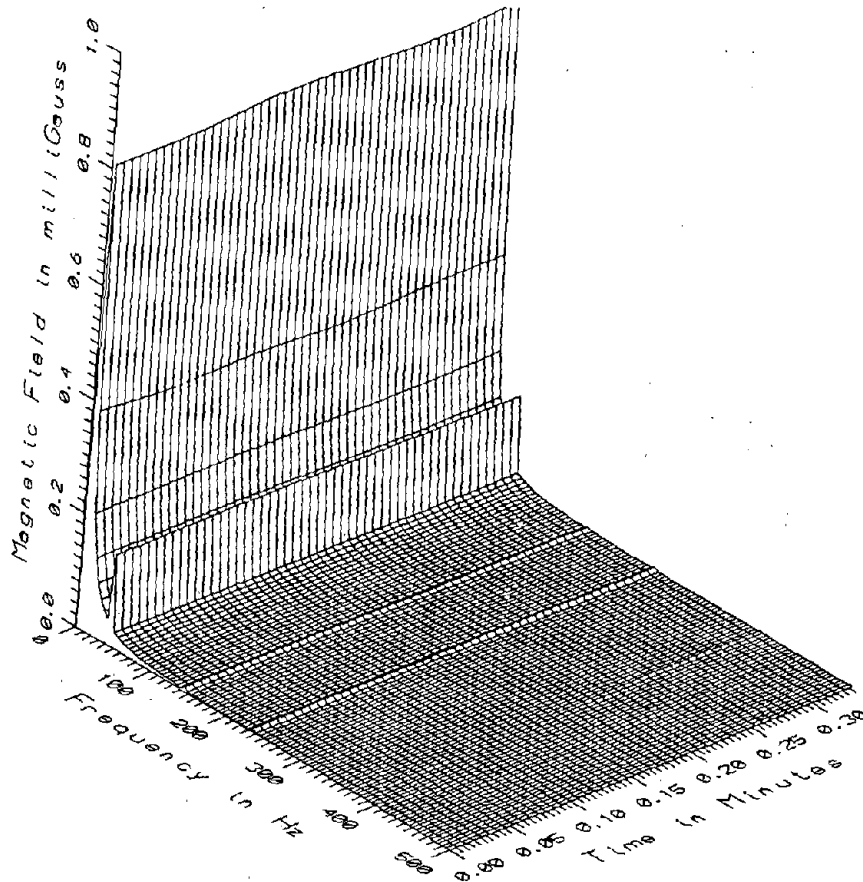

TR7031 - 3.5M WEST OF SOUTH LOOP FEEDER CABLE, GROUND LEVEL

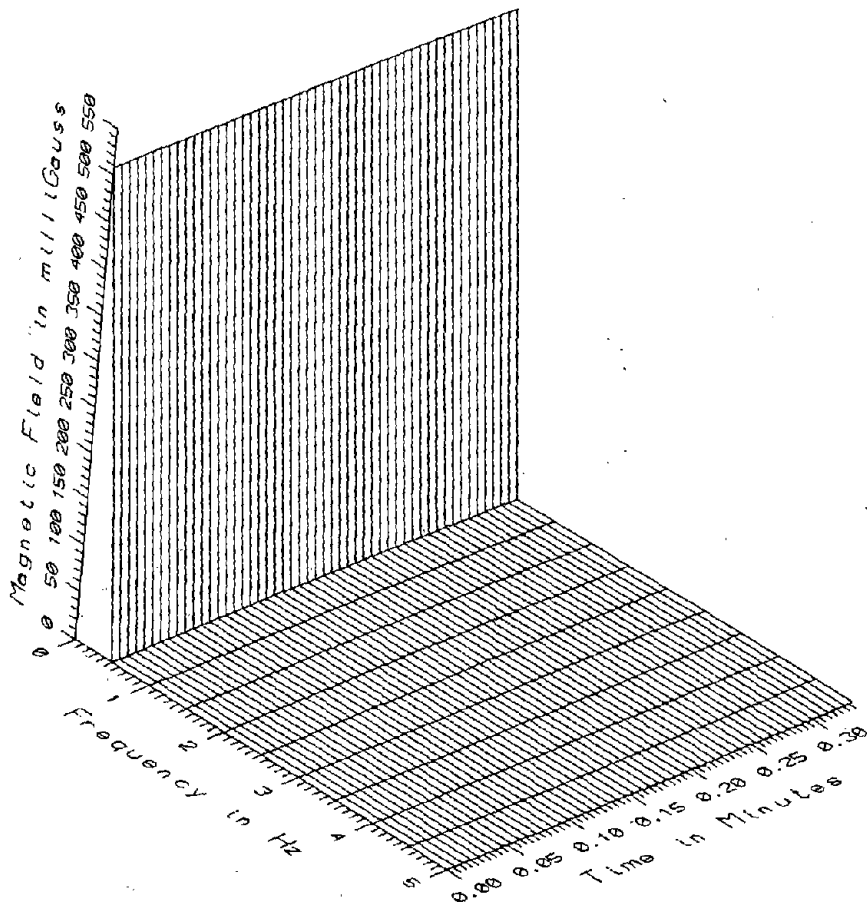

TR7031 - 0.5M EAST OF SOUTH LOOP FEEDER CABLE, GROUND LEVEL

15

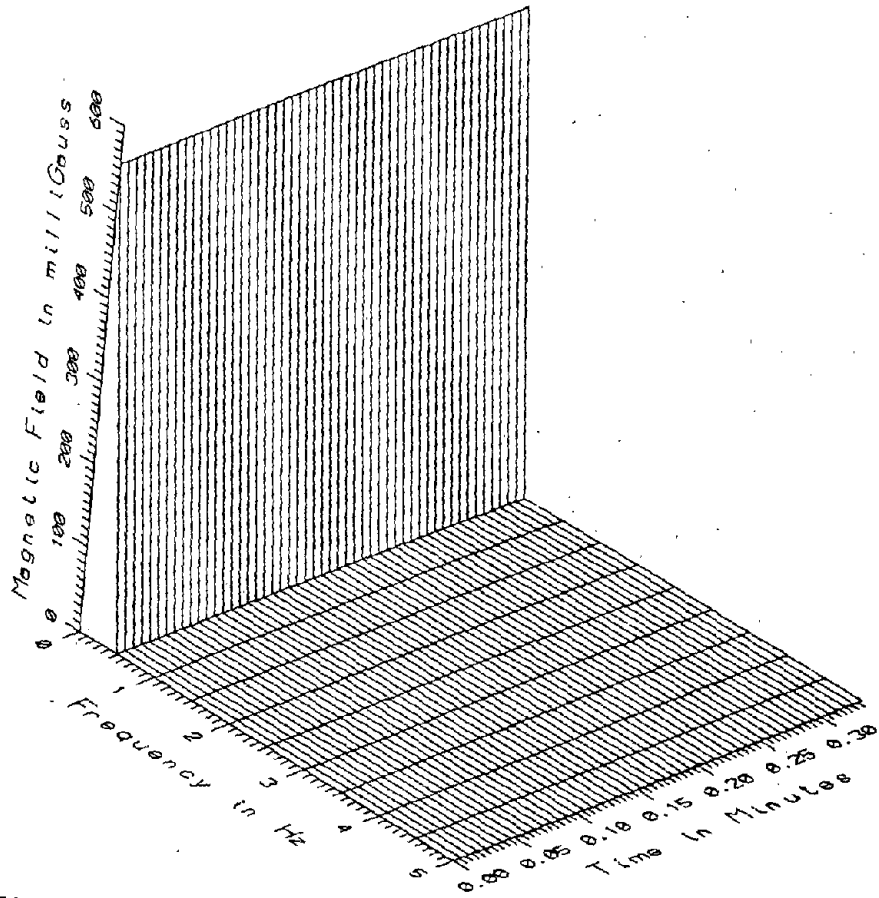

TR7031 - 0.5M WEST OF SOUTH LOOP FEEDER CABLE. GROUND LEVEL

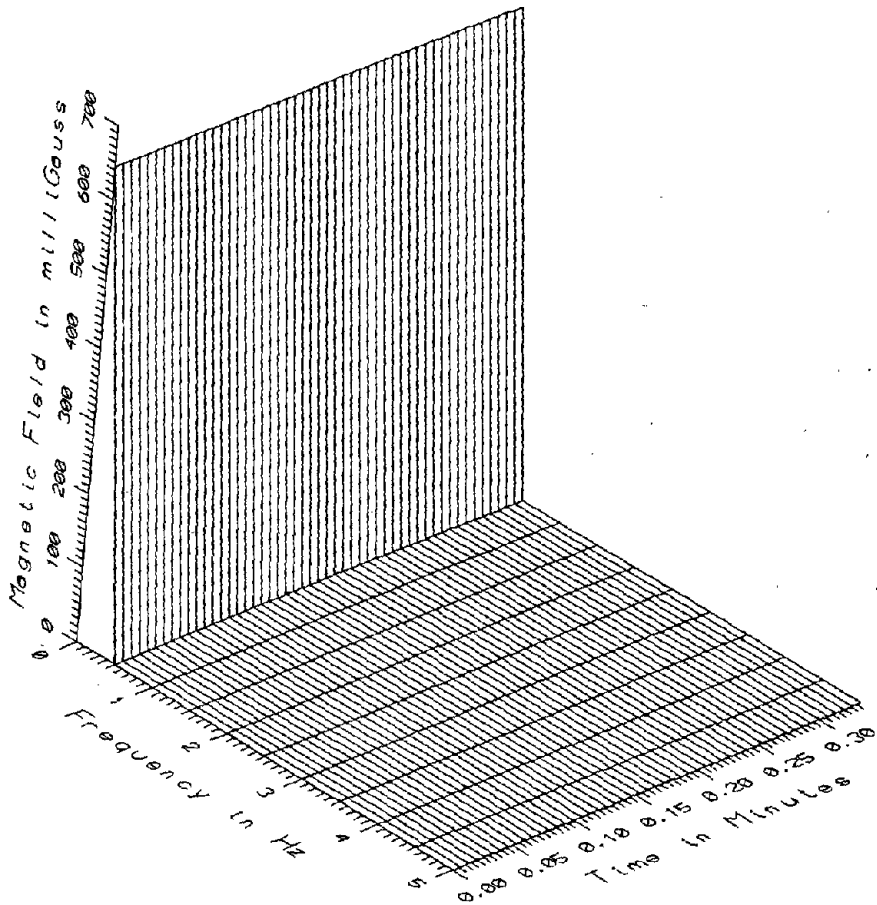

TR7031 - 1.5M WEST OF SOUTH LOOP FEEDER CABLE. GROUND LEVEL

Y-6

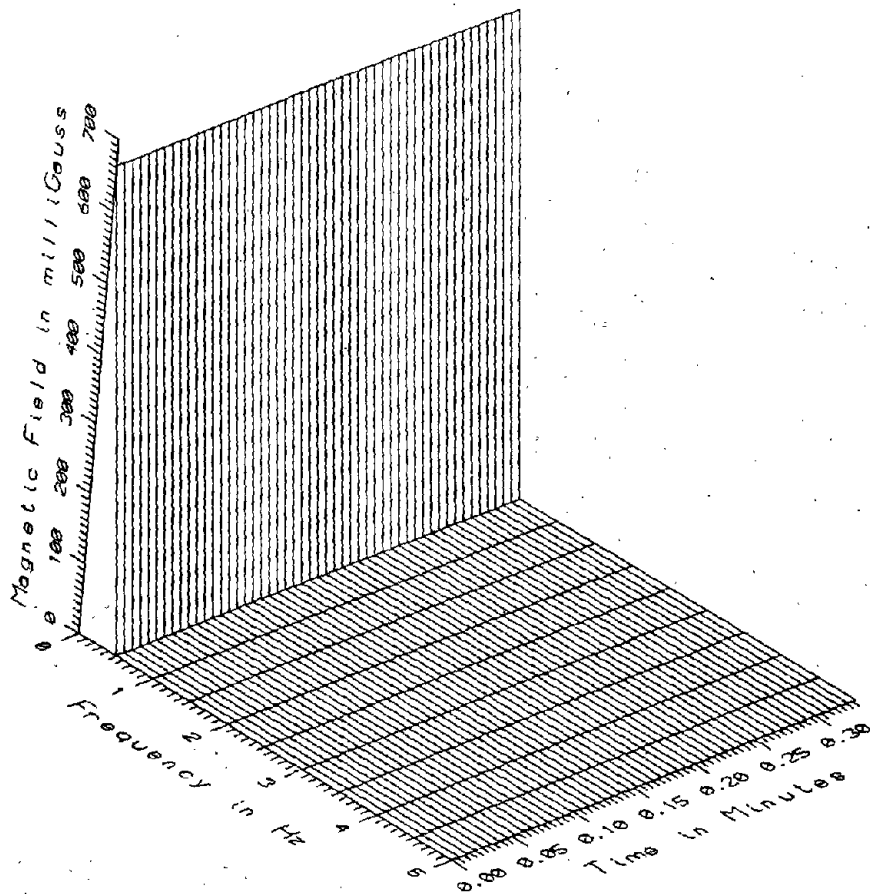

TR7031 - 3.5M WEST OF SOUTH LOOP FEEDER CABLE, GROUND LEVEL

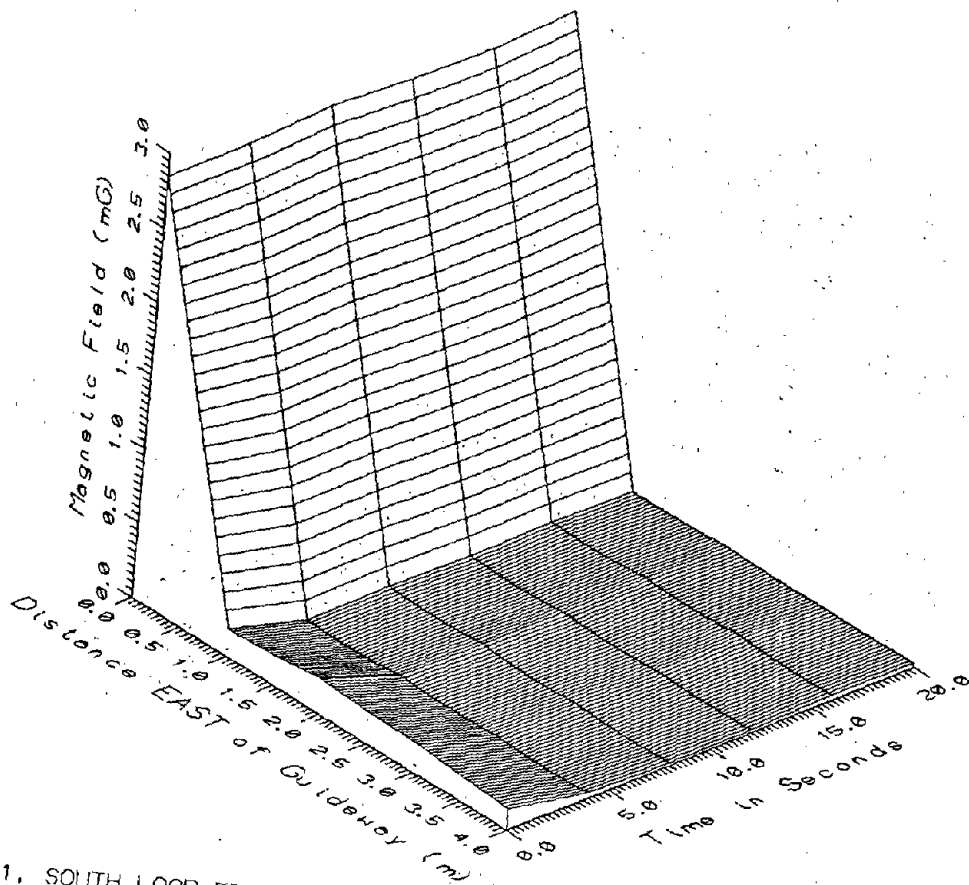

TR7031, SOUTH LOOP FEEDER CABLE 3.5m EAST OF GUIDEWAY - LOW FREQUENCY, 5-45Hz

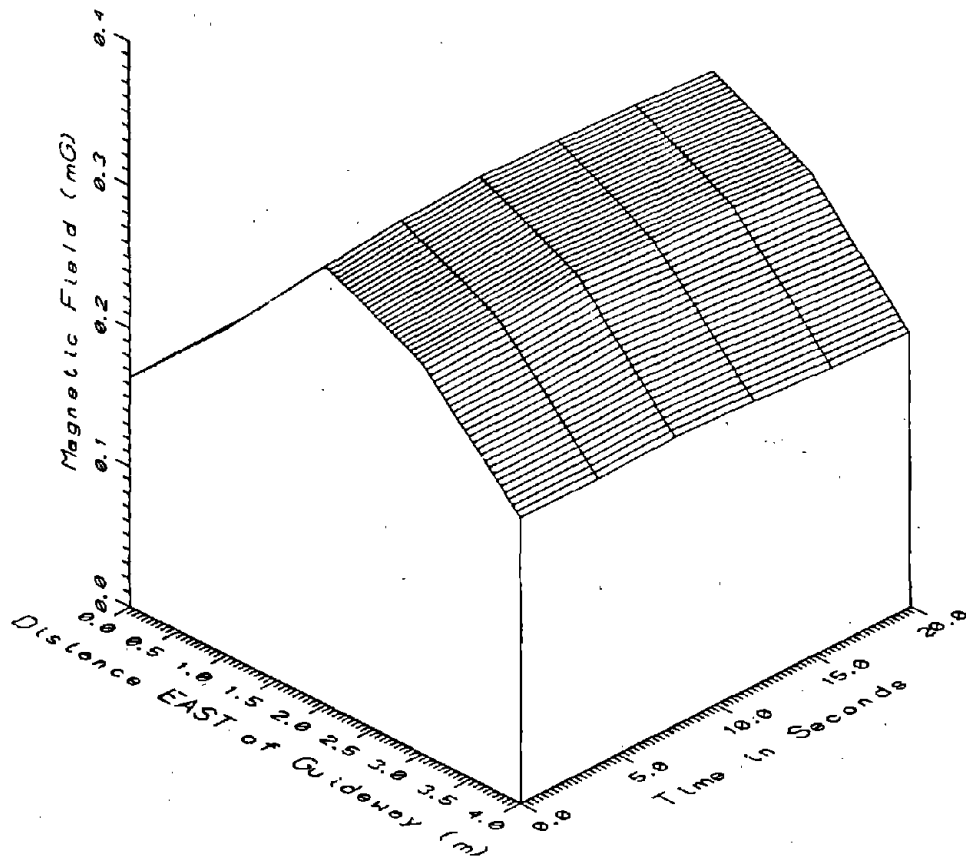

TR7031, SOUTH LOOP FEEDER CABLE 3.5m EAST OF GUIDEWAY - POWER FREQUENCY 50-60Hz

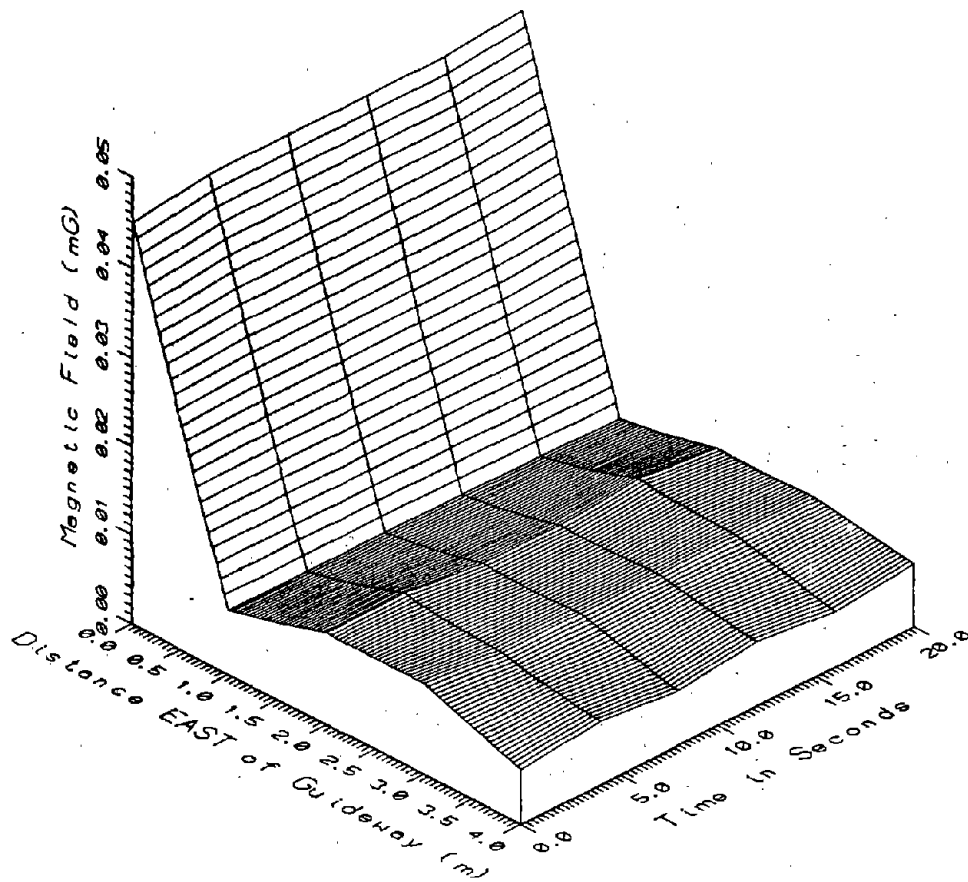

TR7031, SOUTH LOOP FEEDER CABLE 3.5m EAST OF GUIDEWAY - PWR. HARMONICS 65-300Hz

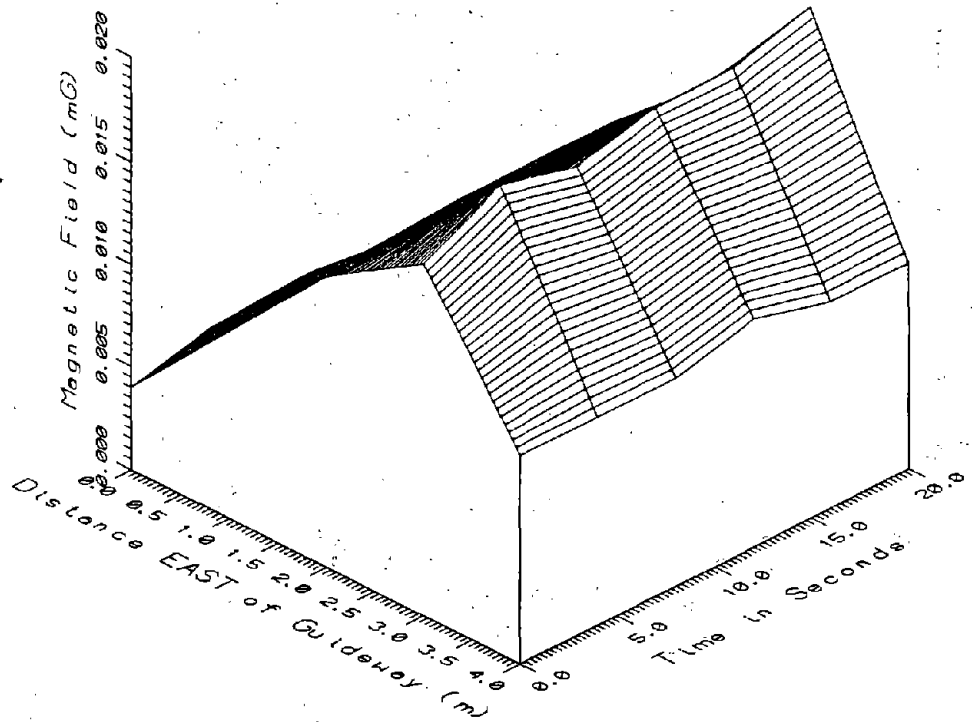

TR7031, SOUTH LOOP FEEDER CABLE 3.5m EAST OF GUIDEWAY - HIGH FREQ 305-2560Hz

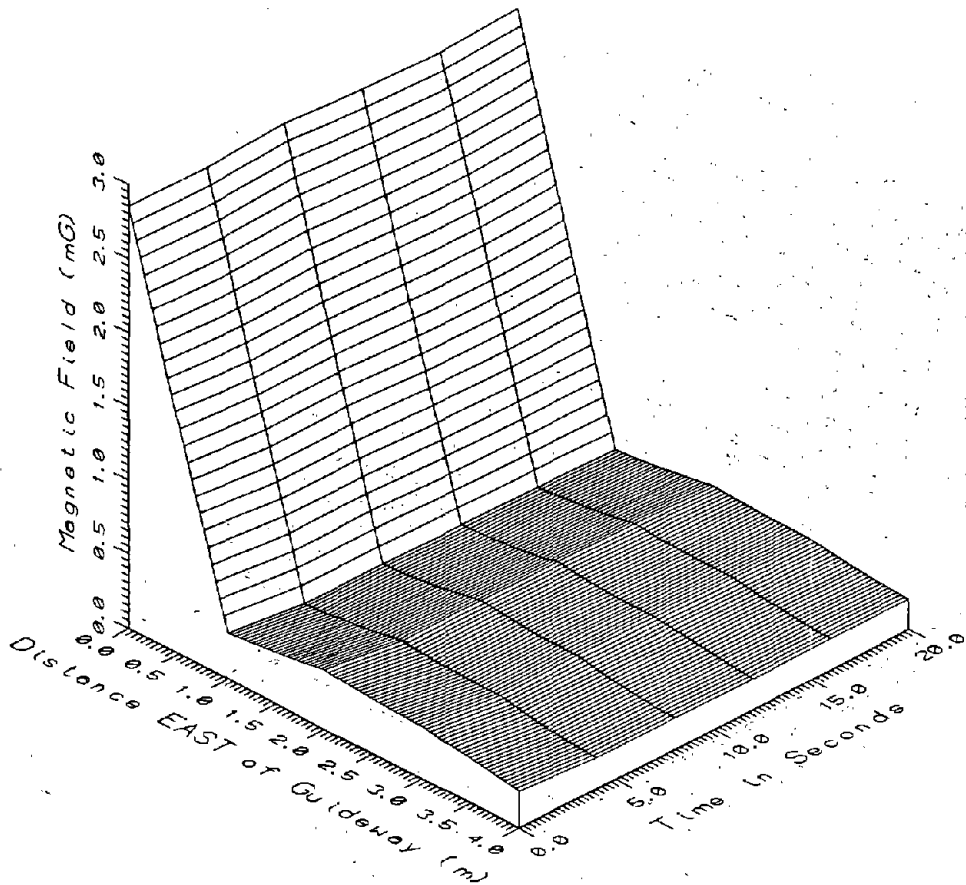

TR7031 SOUTH LOOP FEEDER CABLE 3.5m EAST OF GUIDEWAY - ALL FREQUENCIES 5-2560Hz

APPENDIX Z

DATA SET TR7032

**LATERAL PROFILE ABOVE A FEEDER CABLE
(1 M ABOVE GROUND)**

APPENDIX Z

DATA SET TR7032
 LATERAL PROFILE ABOVE A FEEDER CABLE
 (1 M ABOVE GROUND)

Measurement Setup Code: 28
 Vehicle Status: Running continuously
 Measurement Date: August 10, 1990
 Measurement Time: Start: 16:20:30
 End: 16:40:34
 Number of Samples: 219
 Programmed Sample Interval: 4 sec
 Actual Sample Interval: 5.5 sec

Frequency Spectrum Parameters

<u>Probe Type:</u>	<u>Coil (AC)</u>	<u>Fluxgate (DC)</u>
Maximum Frequency (Hz)	2560	256
Minimum Frequency (Hz)	5	0
Spectral Bandwidth (Hz)	5	0.5

Missing or Suspect Data: The fluxgate sensor 1 m east of the guideway centerline and 2.5 m west of the feeder cable location was inoperative.

SETUP 27 AND 28: FEEDER CABLE

TOP VIEW

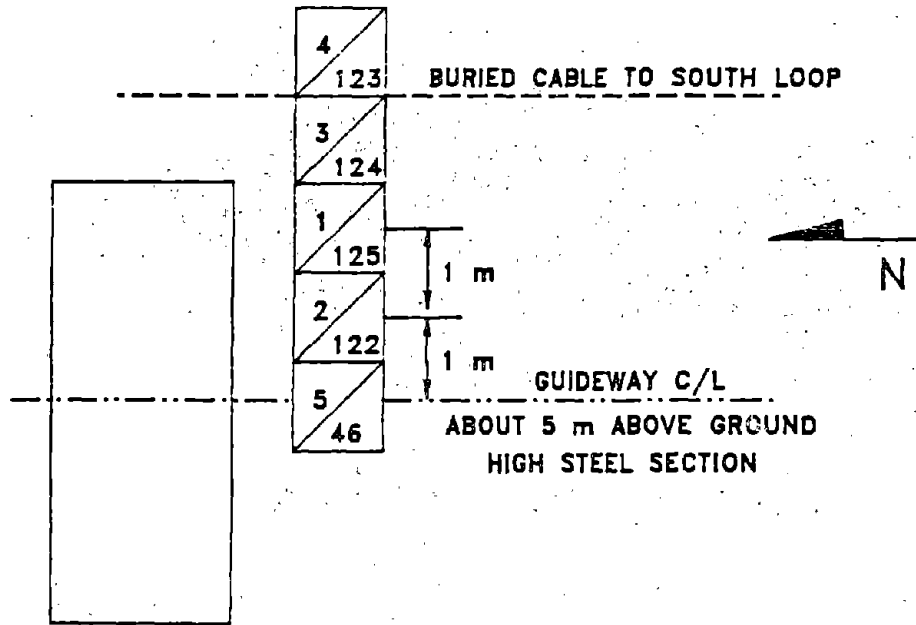

SIDE VIEW

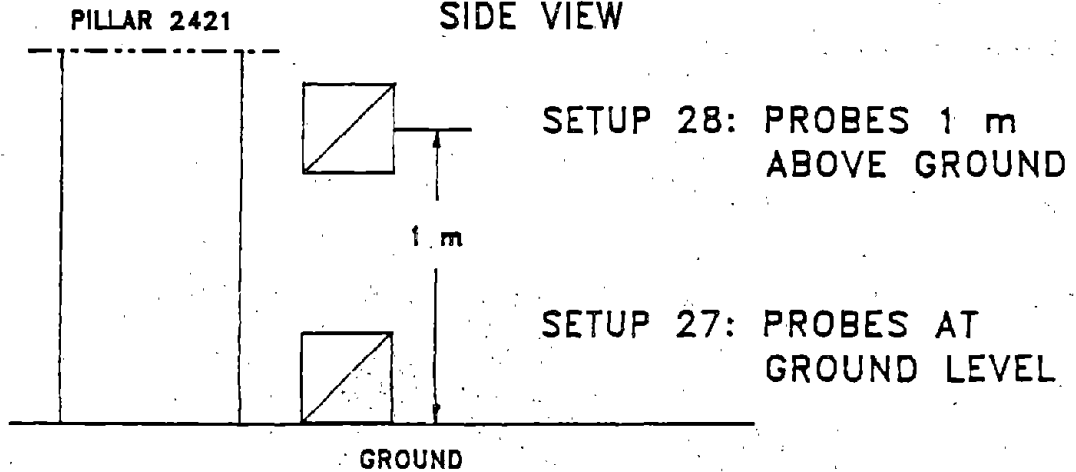

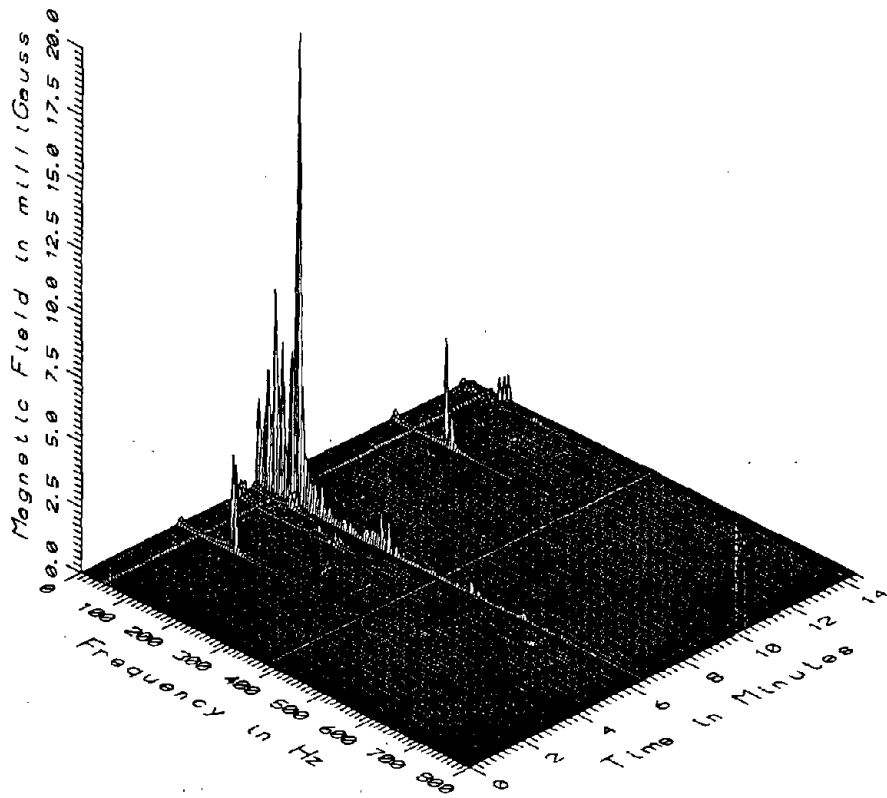

TR7032 - 0.5M EAST OF SOUTH LOOP FEEDER CABLE, GROUND LEVEL

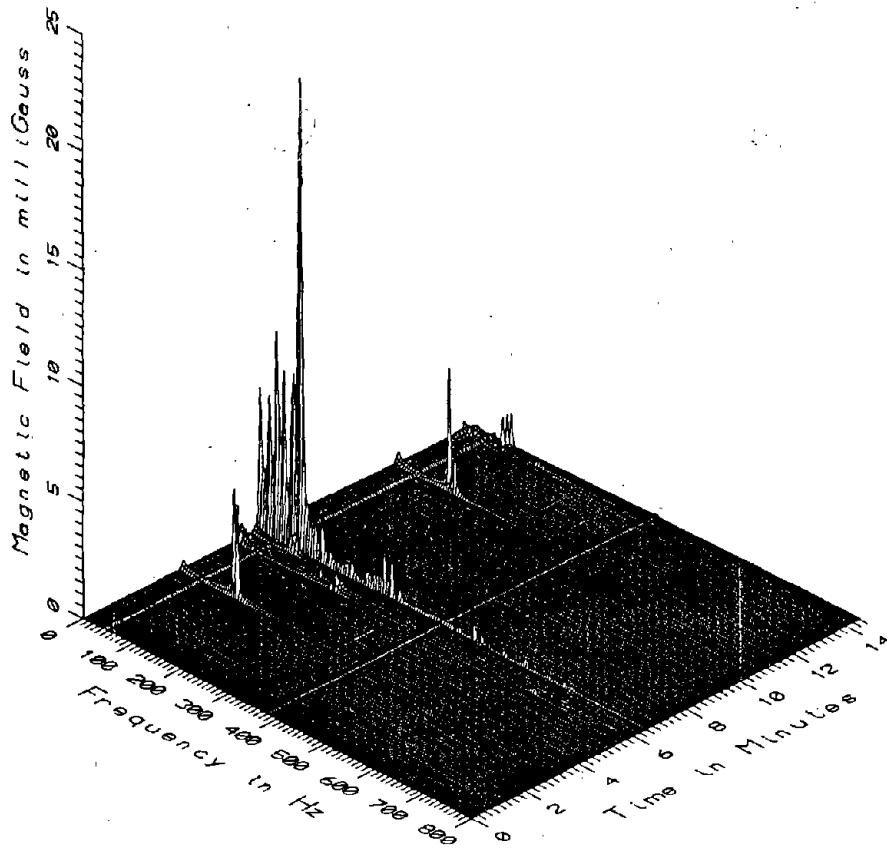

TR7032 - 0.5M WEST OF SOUTH LOOP FEEDER CABLE, GROUND LEVEL

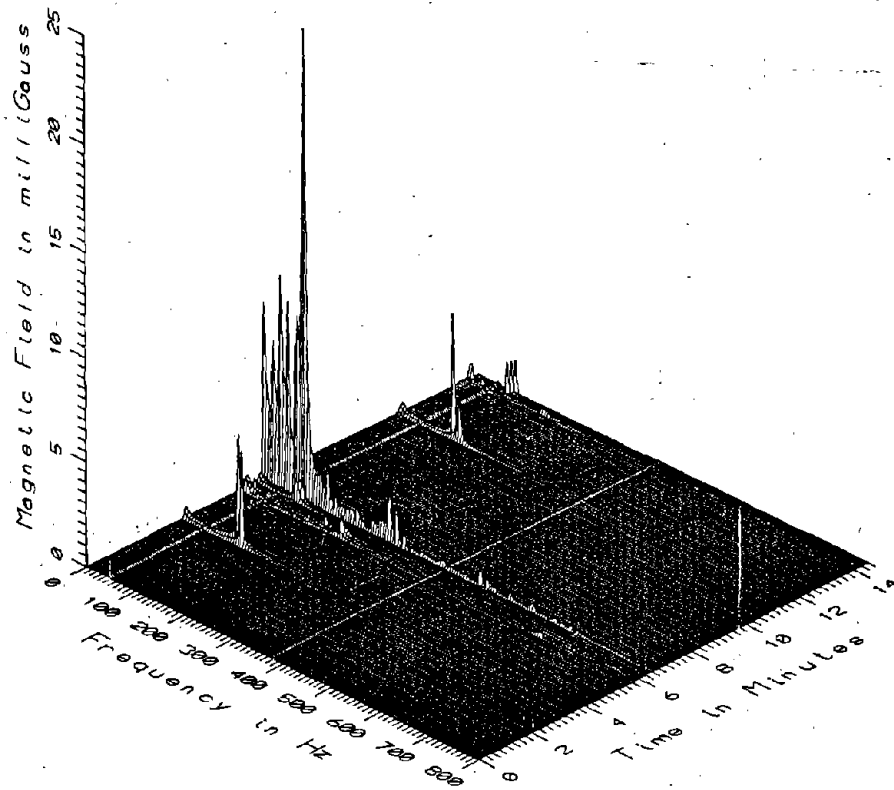

TR7032 - 1.5M WEST OF SOUTH LOOP FEEDER CABLE, GROUND LEVEL

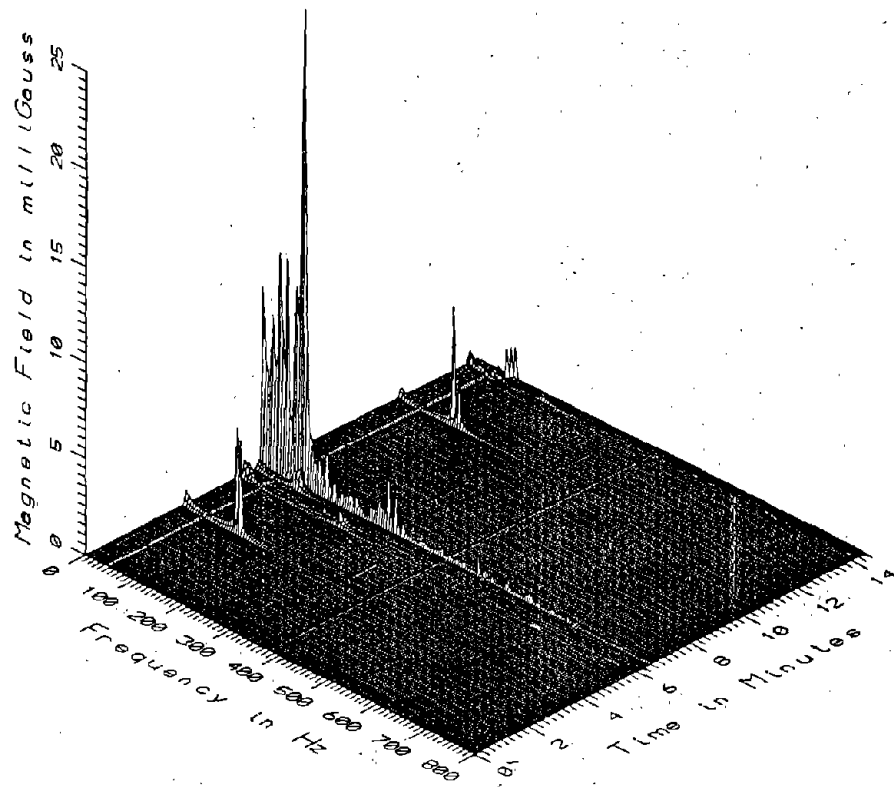

TR7032 - 2.5M WEST OF SOUTH LOOP FEEDER CABLE, GROUND LEVEL

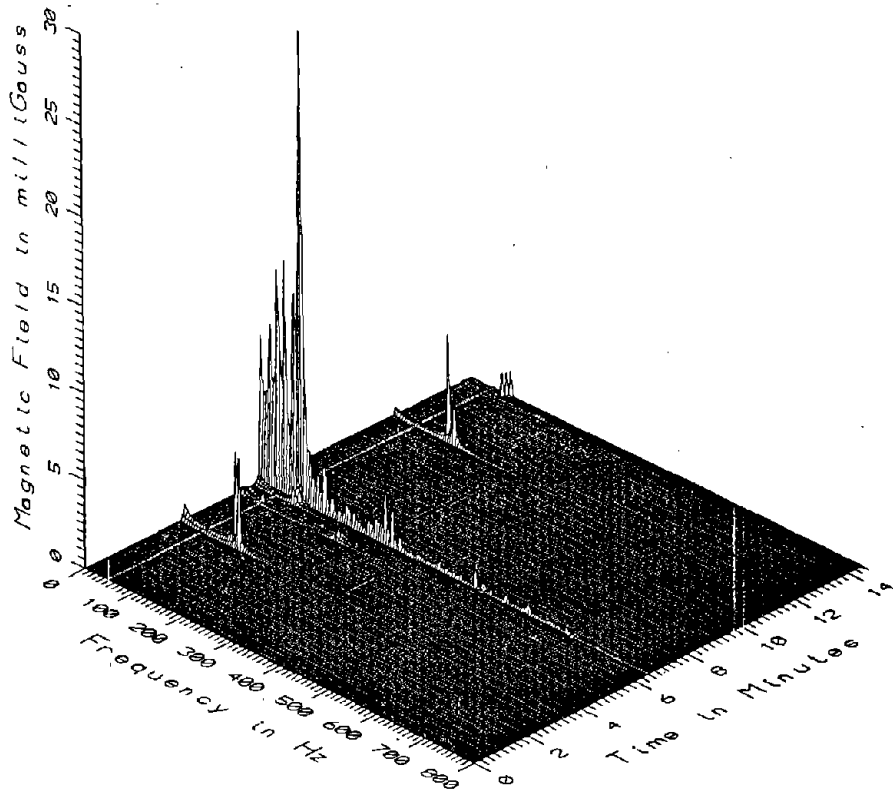

TR7032 - 3.5M WEST OF SOUTH LOOP FEEDER CABLE, GROUND LEVEL

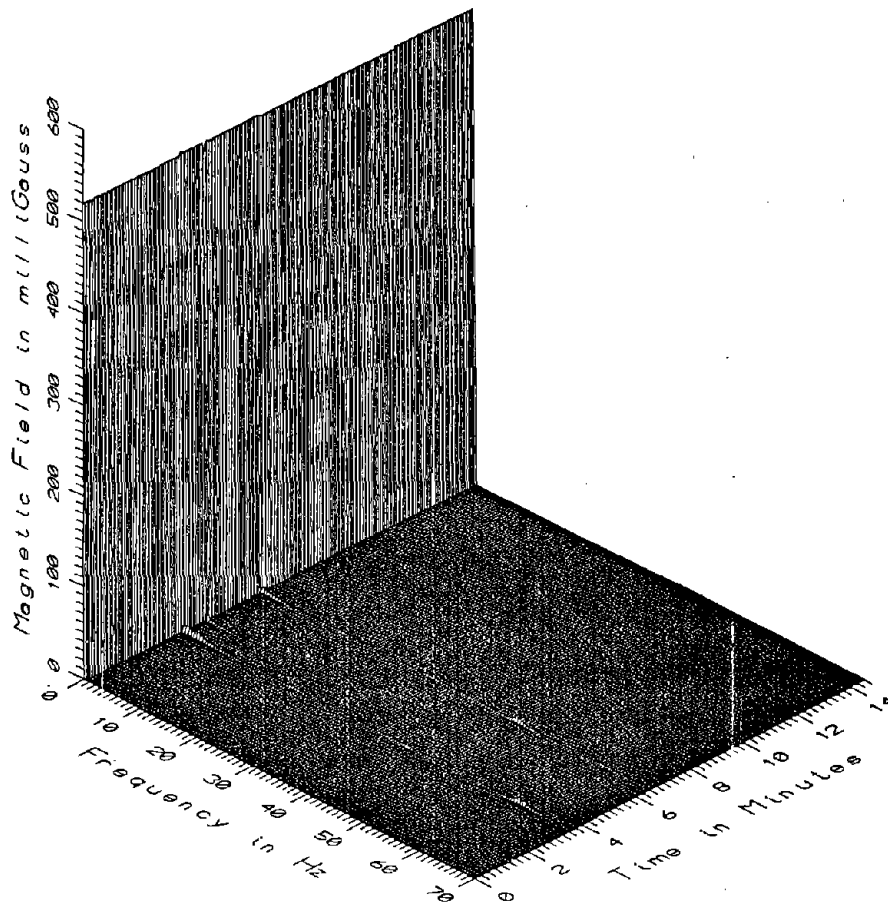

TR7032 - 0.5M EAST OF SOUTH LOOP FEEDER CABLE, GROUND LEVEL

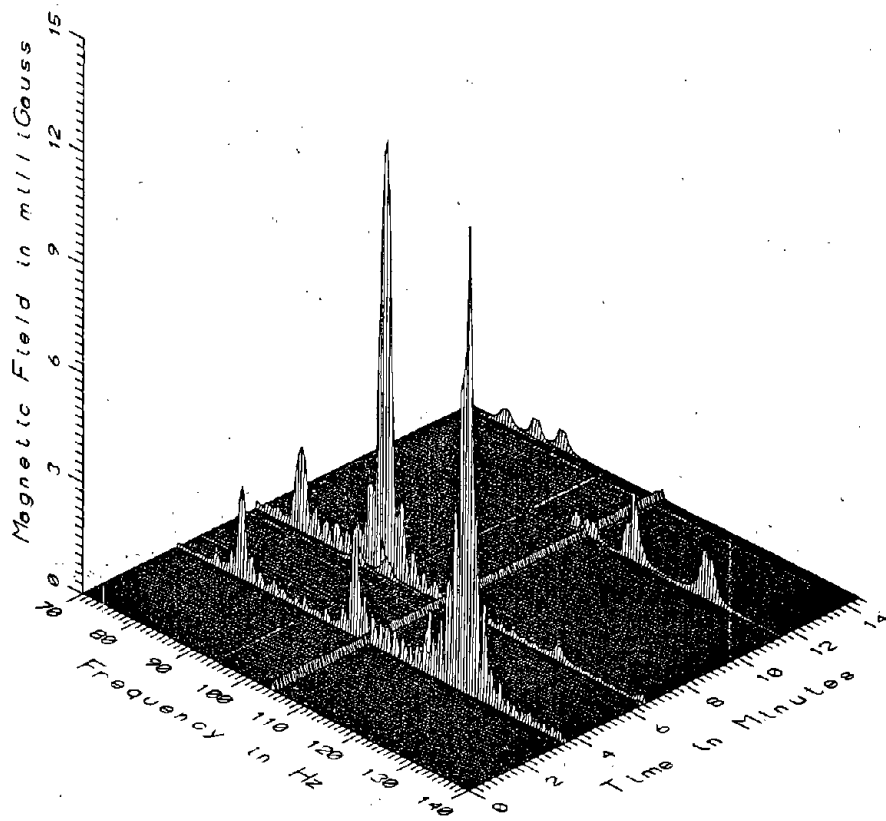

TR7032 - 0.5M EAST OF SOUTH LOOP FEEDER CABLE, GROUND LEVEL

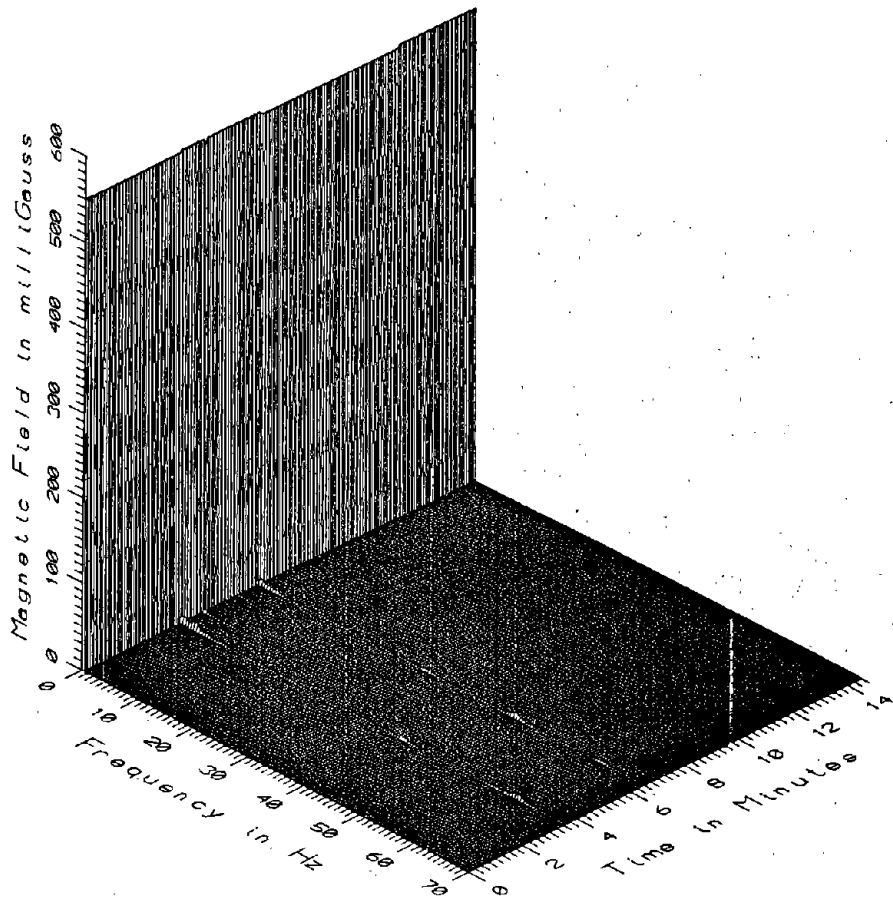

TR7032 - 0.5M WEST OF SOUTH LOOP FEEDER CABLE, GROUND LEVEL

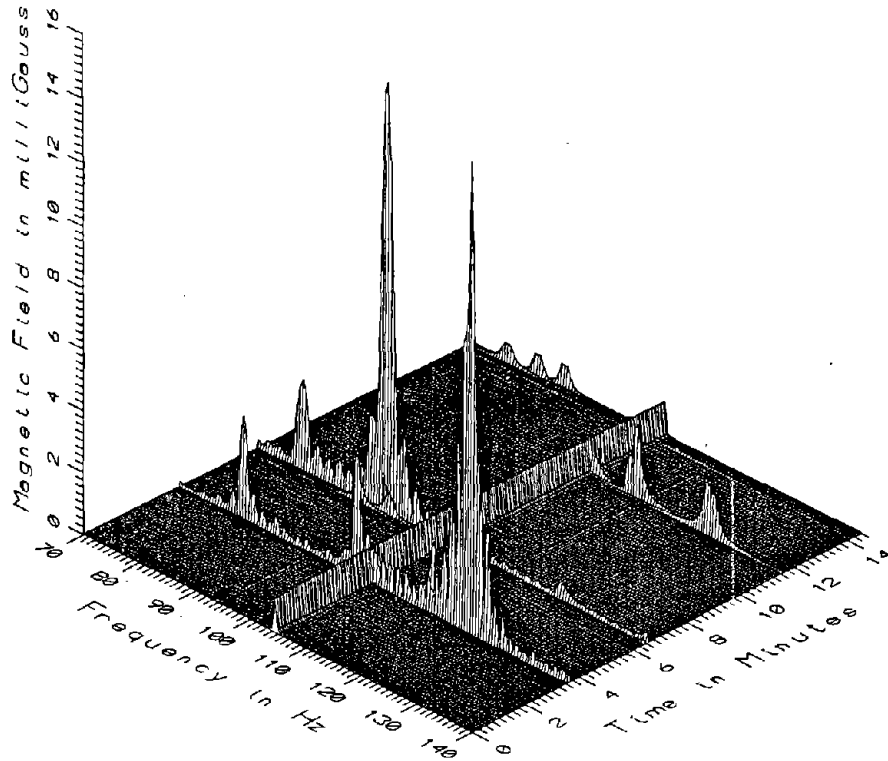

TR7032 - 0.5M WEST OF SOUTH LOOP FEEDER CABLE, GROUND LEVEL

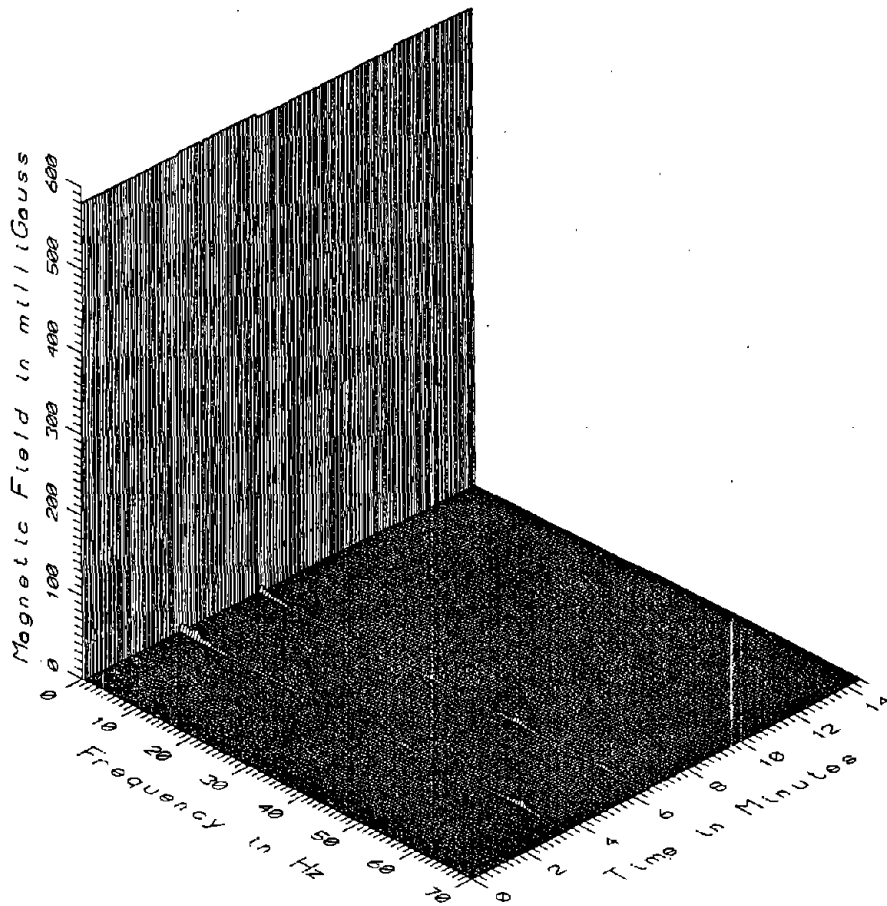

TR7032 - 1.5M WEST OF SOUTH LOOP FEEDER CABLE, GROUND LEVEL

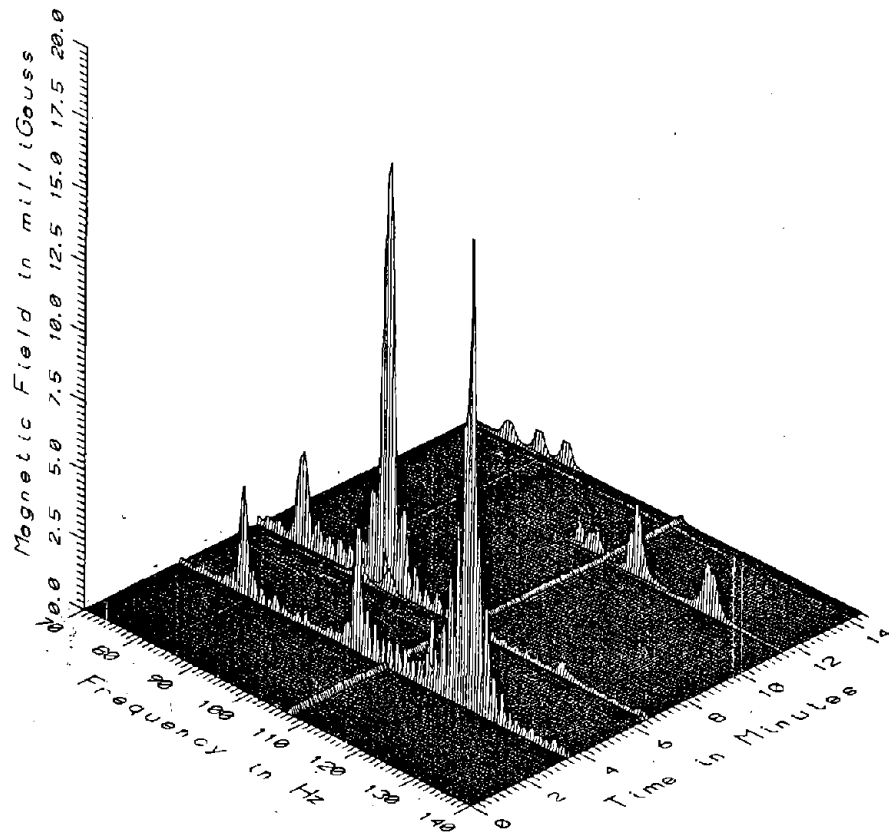

TR7032 - 1.5M WEST OF SOUTH LOOP FEEDER CABLE, GROUND LEVEL

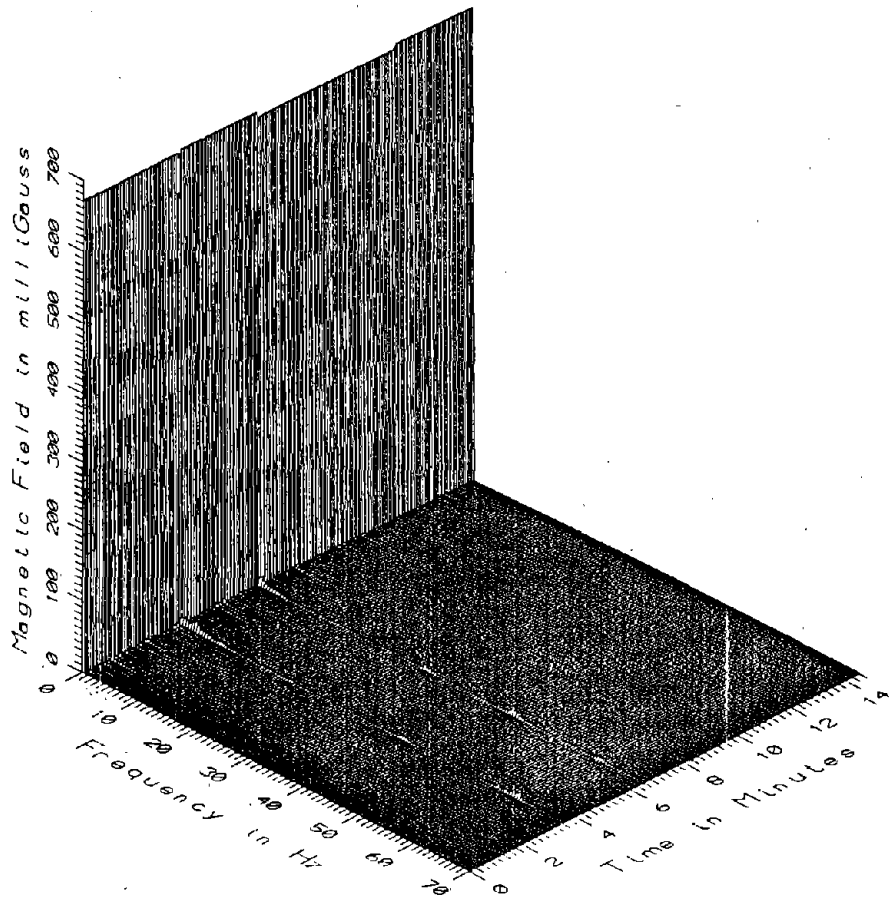

TR7032 - 3.5M WEST OF SOUTH LOOP FEEDER CABLE, GROUND LEVEL

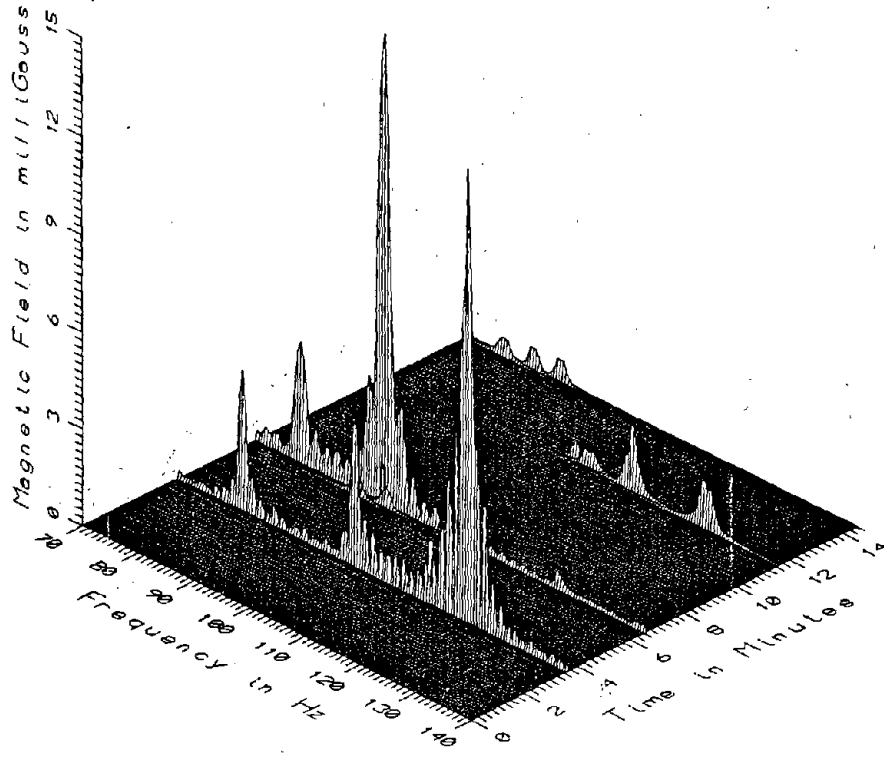

TR7032 - 3.5M WEST OF SOUTH LOOP FEEDER CABLE, GROUND LEVEL

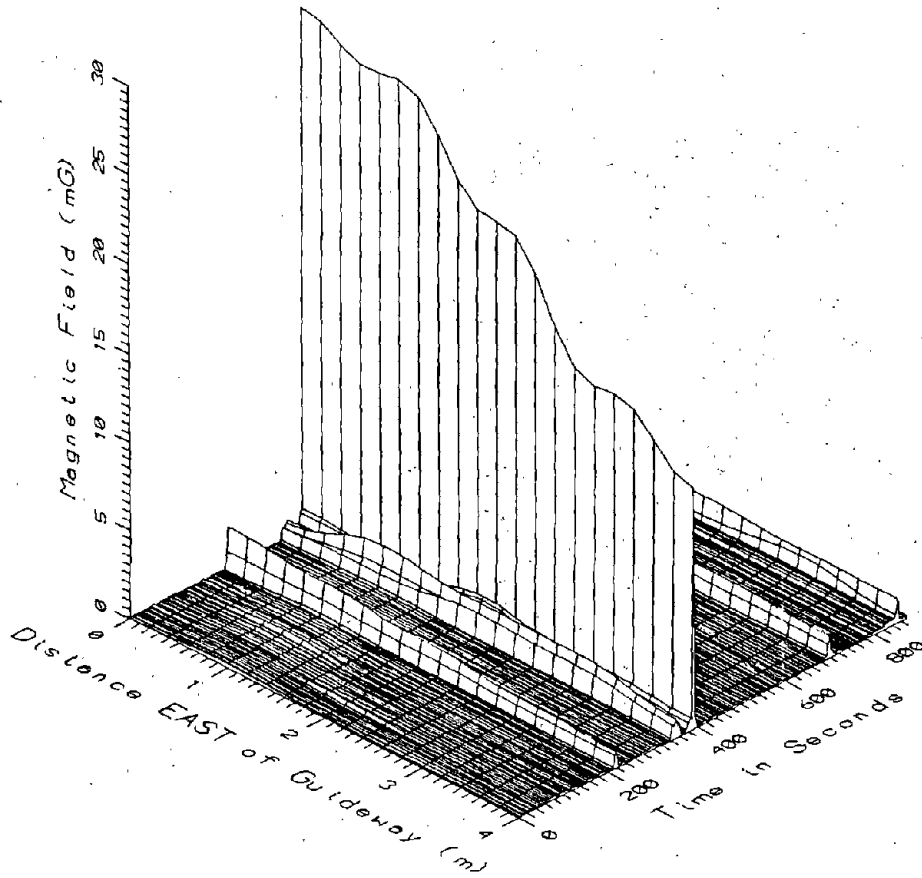

TR7032, SOUTH LOOP FEEDER CABLE 3.5m EAST OF GUIDEWAY - LOW FREQUENCY, 5-45Hz

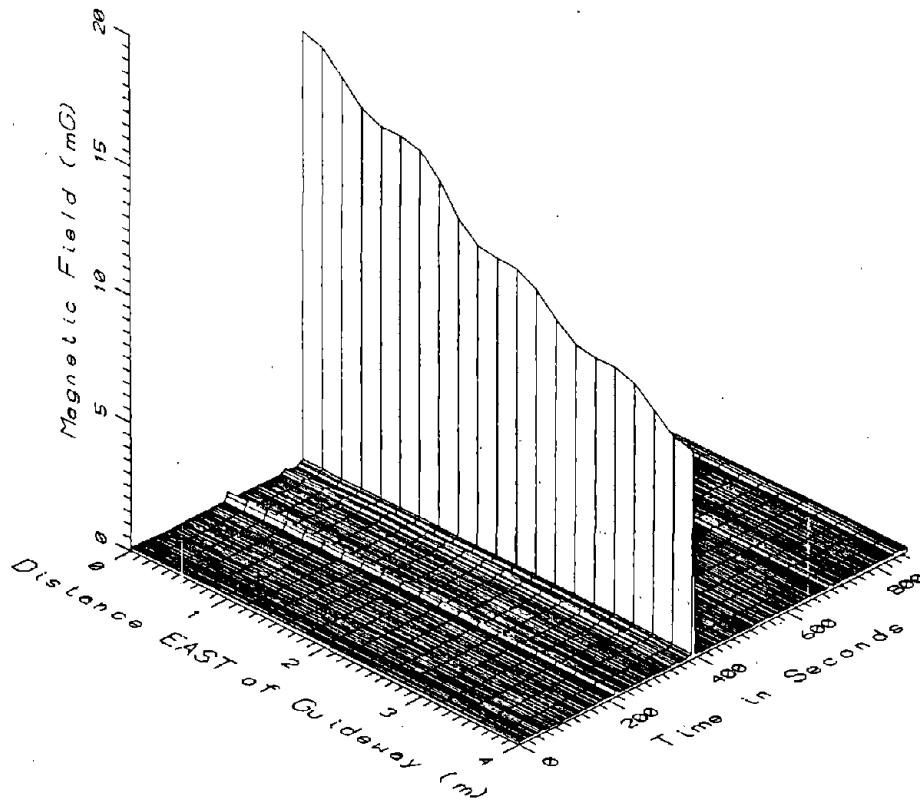

TR7032, SOUTH LOOP FEEDER CABLE 3.5m EAST OF GUIDEWAY - POWER FREQUENCY 50-60Hz

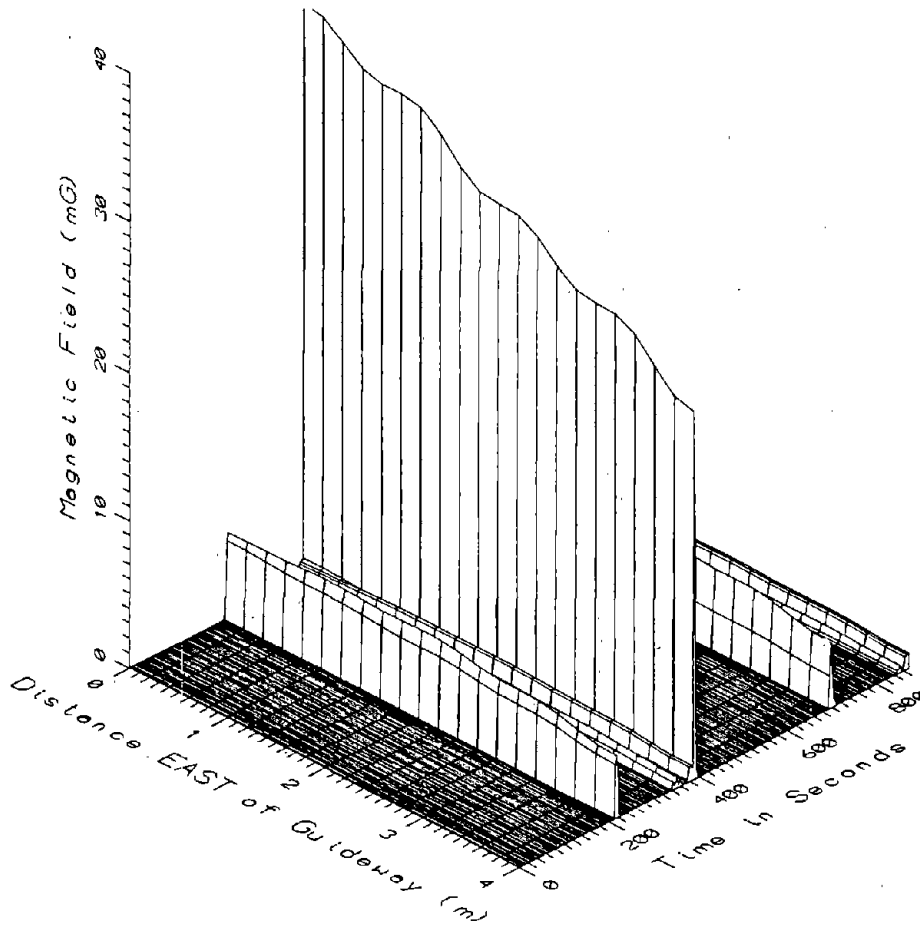

TR7032, SOUTH LOOP FEEDER CABLE 3.5m EAST OF GUIDEWAY - PWR. HARMONICS 65-300Hz

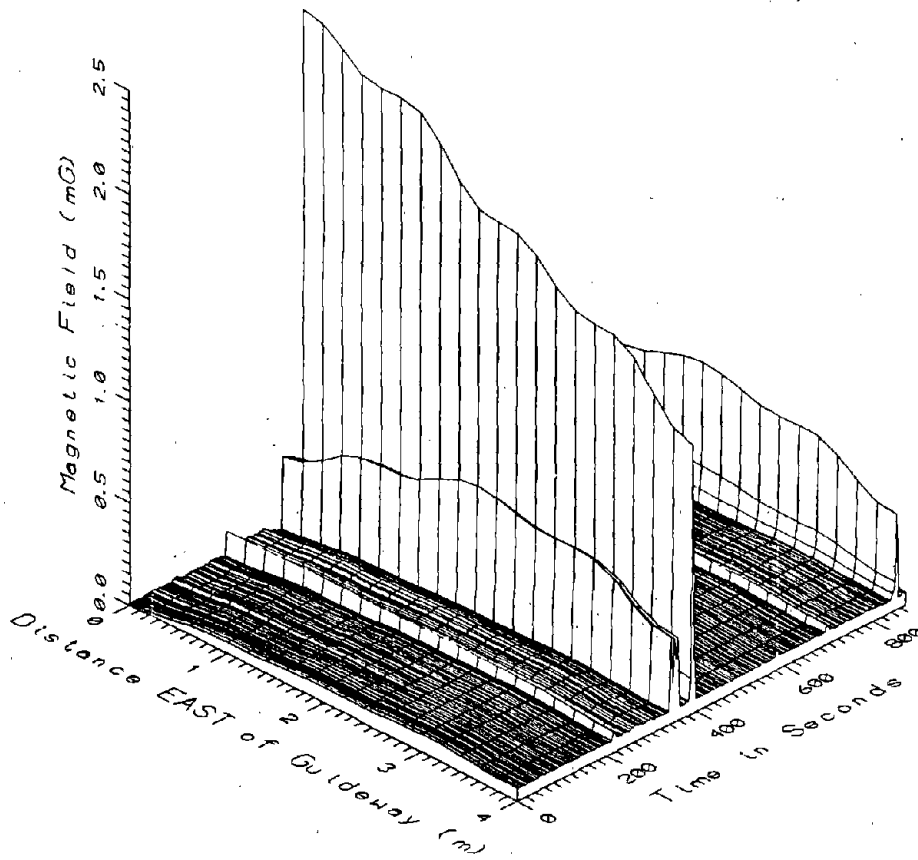

TR7032, SOUTH LOOP FEEDER CABLE 3.5m EAST OF GUIDEWAY - HIGH FREQ. 65-2560Hz

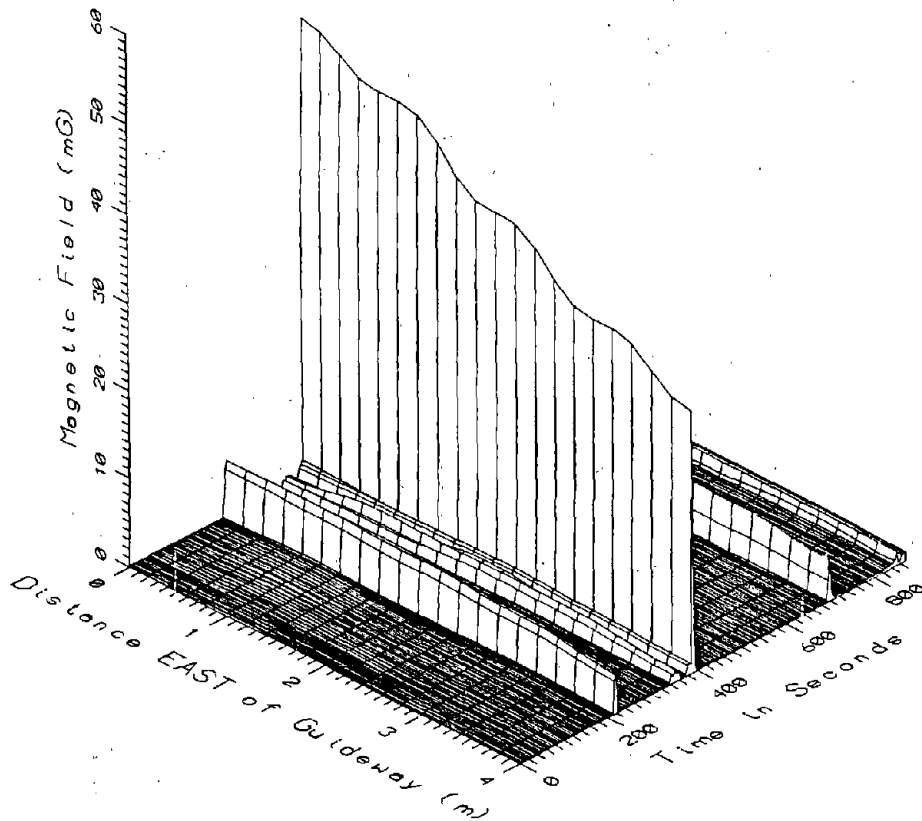

TR7032 SOUTH LOOP FEEDER CABLE 3.5m EAST OF GUIDEWAY - ALL FREQUENCIES 5-2560Hz