

Reference  
81-25

U.S. Department of Transportation  
Federal Aviation Administration

---

# Fifth Human Factors Workshop On Aviation Transcript

July 7-8, 1981



May 1982

Presented at  
Mike Monroney Aeronautical Center  
Oklahoma City, OK

21/05/2018  
26-18



REPORT NUMBER: FAA-ASF-81-7  
DOT-TSC-FAA-81-25

DOT/FAA  
FIFTH HUMAN FACTORS WORKSHOP  
ON AVIATION

Sponsored by the  
U.S. DEPARTMENT OF TRANSPORTATION  
FEDERAL AVIATION ADMINISTRATION

Presented at the  
Mike Monroney Aeronautical Center  
Oklahoma City, Oklahoma  
July 7 & 8, 1981

## FOREWORD

This document is a verbatim transcript of the proceedings of the Fifth Human Factors Workshop held at the Mike Monroney Aeronautical Center in Oklahoma City, Oklahoma, on July 7-9, 1981. The Sixth Human Factors Workshop was held at the same facility on July 7 and 8, 1981.



## TABLE OF CONTENTS

<u>SESSION 1</u>	<u>PAGE</u>
<u>OPENING REMARKS</u>	
Benjamin Demps..... Director Mike Monroney Aeronautical Center	1
Walter Luffsey..... Associate Administrator for Aviation Standards Federal Aviation Administration	2
J. Robert Dille, M.D..... Chief Civil Aeromedical Institute	5
<u>SPEAKERS</u>	
Dr. H. L. Reighard..... Federal Air Surgeon Federal Aviation Administration	7
William R. Kirkham, M.D., Ph.D..... Chief, Aviation Toxicology Laboratory Civil Aeromedical Institute	12
Richard F. Chandler..... Chief, Protection and Survival Laboratory Civil Aeromedical Institute	19
Charles R. Crane, Ph.D..... Biochemist, Aviation Toxicology Laboratory Civil Aeromedical Institute	23
D. DeSteiguer..... Chief, Survival Research Unit Civil Aeromedical Institute	26
Michael T. Lategola, Ph.D..... Chief, Cardiorespiratory Research Unit Civil Aeromedical Institute	30
Alvin M. Revzin, Ph.D..... Neuropharmacology Research Unit Civil Aeromedical Institute	36
William E. Collins, Ph.D..... Chief, Aviation Psychology Laboratory Civil Aeromedical Institute	40

TABLE OF CONTENTS (CONTINUED)

<u>SESSION 1 (CONTINUED)</u>	<u>PAGE</u>
Carlton E. Melton, Ph.D..... Chief, Aviation Physiology Laboratory Civil Aeromedical Institute	46
James O. Boone, Ph.D..... Chief, Selection and Testing Research Unit Civil Aeromedical Institute	51
 <u>SESSION 2</u>	
 <u>SPEAKERS</u>	
Alan E. Diehl, Ph.D..... Program Scientist, Office of Aviation Medicine Federal Aviation Administration	58
Richard Snyder, Ph.D..... Head, Biomedical Department University of Michigan	58
Stanley N. Roscoe, Ph.D..... Head, Behavioral Engineering Laboratory New Mexico State University	76
Col. George C. Mohr, USAF MC..... Commander, USAF Aviation Medical Research Laboratory Wright-Patterson AFB, Oh.	95
Richard L. Sulzer, Ph.D. .... Consultant Wright State University	102
William J. Cox ..... Independent Aviation Consultant Falls Church, Va.	110
C. William Connor..... Adjunct Professor of Aviation Psychology Embry-Riddle University	118
Saul Sells, Ph.D..... Director, Institute of Behavioral Research Texas Christian University	120
Joseph Tucker, Ph.D..... Coordinator, Center for Educational Technology Catholic University	127

TABLE OF CONTENTS (CONTINUED)

<u>SECTION 2 (CONTINUED)</u>	<u>PAGE</u>
Kay Avery.....	134
Manager, Emergency Procedures Training	
American Airlines	
 <u>SECTION 3</u>	
Capt. J. E. Carroll.....	140
Vice President, Flight Standards and Training	
United Airlines	
 Robert Rose, M.D.....	147
University of Texas Medical School	
Galveston, Texas	
 Robert Wick, M.D.....	157
American Airlines	
Dallas, Texas	
 Stanley R. Mohler, M.D.....	167
Wright State University	
Dayton, Ohio	
 Rick Clark.....	171
Flight Safety Foundation	
Arlington, Va.	
 John R. Harrison.....	178
Director, Office of Aviation Safety	
Federal Aviation Administration	
 <u>ADDITIONAL MATERIALS ATTACHED</u>	
Supplementary Materials Submitted at the Fifth Human Factors Workshop	
 Additional Comments Presented during Workshop C	
 Bibliography and Figures from Dr. Joseph Tucker's Presentation	
 Questionnaires Distributed in Workshop A, Biomedical and Behavioral Factors in Pilot Operations	

## LIST OF ACRONYMS

AFTI	Advanced Fighter Technology Integration
ALPA	Airline Pilot Association
ALSF	Approach Light System with Sequenced Flashing Lights in ILS Cat-II Configuration
AME	Aviation Medical Examiner
AMRL	Aerospace Medical Research Lab
AOPA	Aircraft Owners and Pilots Association
APA	Allied Pilots Association
ARD	Systems Research & Development Service
ASI	Airspeed Indicator
ASRS	Aviation Safety Reporting System
ASTM	American Society of Testing and Materials
ATC	Air Traffic Control
ATCS	Air Traffic Control Specialist (System)
BFR	Biennial Flight Review
CAA	Civil Aeronautics Administration
CAI	Computer Assisted Instruction
CAMI	Civil Aeromedical Institute
CARI	Civil Aeromedical Research Institute
CAS	Collision Avoidance System
CDTI	Cockpit Display of Traffic Information
CODE	Controller Decision Evaluation
CRT	Cathode Ray Tube

CSC	Civil Service Commission
DER	Designated Engineering Representative
DME	Distance Measuring Equipment
EEOC	Equal Employment Opportunity Commission
FAA	Federal Aviation Administration
FAR	Federal Air Regulation
FIFO	First In First Out
FPL	Full Performance Level
GA	General Aviation
GADO	General Aviation District Office
GPWS	Ground Proximity Warning System
HSI	Horizontal Situation Indicator
HUD	Head Up Display
ICAO	International Civil Aviation Organization
IFALPA	International Federation of Airline Pilots Associations
IFR	Instrument Flight Rules
ILS	Instrument Landing System
INA	Inertial Navigation System
KLM	Royal Dutch Airline
LOFT	Line Oriented Flight Training
LRCA	Long-Range Combat Aircraft
MCAT	Multiplex Controller Aptitude Test
MLS	Microwave Landing System
MMR	Mouth-to-mouth Resuscitation
MTPB	Multiple Task Performance Battery
NAFEC	National Aviation Facilities Experimental Center

NASA	National Aeronautics & Space Administration
NAV Star	(A Navigation Satellite)
NBS	National Bureau of Standards
NTSB	National Transportation Safety Board
OAM	Office of Aviation Medicine
OPM	Office of Personnel Management
OSHA	Occupational Safety and Health Administration
PATCO	Professional Air Traffic Controllers Organization
PSA	Pacific Southwest Airlines
REILS	Runway End Identifier Lights
SAE	Society of Automotive Engineers
SAFER	Special Aviation Fire and Explosion Reduction Committee
SFO	San Francisco, CA.
STAI	State-Trait Anxiety Level
TC	Terminal Control
TRSB/MLS	Time Referenced Scanning Beacon/Microwave Landing System
TSO	Technical Standard Order
VASI	Visual Approach Slope Indicator
VFR	Visual Flight Rules
4D NAV	(4 Dimensional Navigation)

SESSION 1  
(July 7, 1981)

MR. DEMPS: Good morning and welcome to Oklahoma City and the Mike Monroney Aeronautical Center. I'm Benjamin Demps, the Director of the Aeronautical Center, and I'm pleased to host such a distinguished group of professional visitors to the Center for these two seminars.

We are combining for this greeting and for some of the later activities the participants of both the Human Factors workshop on maintenance and the Human Factors workshop on aviation medicine. I'm sure you know that the benefits to be derived from your separate but concurrently happening seminars will be of great benefit to the aviation industry.

I also noticed that your programs refer to the Fifth Human Factors Workshop on Biomedical and Behavioral Factors and the Sixth Human Factors Workshop on Aviation Maintenance.

This indicates then a continuing effort in each of those separate endeavors, and I'm pleased to see you joining us at this time. The research at the Civil Aeromedical Institute is of vital importance to the agency, the Department of Transportation, the aviation industry and the public.

During your stay here, you will be presented information on the multifaceted mission of the Aeronautical Center.

By the way, at any time during this, the period of time that you'll be here, if there's anything that you wish to do at the Aeronautical Center, if there are any meetings that you wish to have with any of the people here at the Aeronautical Center here, please, let us know. We will readily and quickly accommodate your needs.

I would like to introduce some of your host members. First, Dr. Reighard, Federal Air Surgeon, Office of Aviation Medicine, Federal Aviation Administration (FAA), and John Harrison, Director, Office of Aviation Safety.

The next two gentlemen will be speaking to you in a few moments, Mr. Walter Luffsey, Associate Administrator for Aviation Standards, FAA Headquarters in Washington; and Mr. Luffsey will be talking about human factors in aviation medicine.

Dr. Robert Dille will open the session for the workshop on biomedical and behavioral factors. Dr. Dille is the Chief, Civil Aeromedical Institute. So once again, welcome to Oklahoma City Aeronautical Center and I hope your meetings are fruitful. Thank you.

MR. LUFFSEY: Good morning. Let me add my welcome to our fifth and sixth workshop on human factors. I am also delighted with the turnout that we have. I am impressed with the professional distribution that we have.

I apologize that we have to do two of these at once and create the split sessions. But I also wanted to add somewhat of a note of finality to the continuing workshop and dialogue that we have had in this kind of setting.

I was somewhat concerned that this could protract over a long period of time and I do have some program commitments and I get the feeling that perhaps we haven't really articulated well what we planned to do with all this information we've been acquiring.

So I would like to talk about the process that we plan to follow. I don't want to imply by what I said that we want to stop the dialogue, just the formal setting that we had been using since November of last year.

It was our intent to try to cover a range of topics that have been associated in some way with human factors and I might add immediately that I'm not sure that we all have a common definition of human factors and I can't proffer one.

So I challenge you perhaps even to give us a reasonable definition of human factors. Our only point was to cover a range of subjects that have been mentioned and have been associated with human factors, whatever it's defined as.

What we have done is that starting back, I believe, in November of last year, we tried to cover a set of panels and a subject area which effectively involved transport category operations, recognizing in full that the general audience would have an opportunity to discuss any facet related to human factors at any time.

We followed on with that a second workshop in January, and there we tried to put our focus fundamentally on commuter aviation. We had the opportunity to piggyback on the commuter symposium which was being held.



Following that, in March, back at the Transportation Systems Center, we held another conference workshop and at that conference we tried to focus on some of the Air Traffic Control (ATC) issues and particularly part of the helicopter operation. There was an expression early on that we had not really focused as we should have on helicopters, either manufacturing or operation. So we tried to accommodate that in a workshop setting.

Following that, in May, at the Technical Center in Atlantic City, we hosted a workshop under the good graces of Mr. Yulo and his arrangements. We were able to focus specifically on the ATC function and its interface with the total system.

That was the first real session where we structured in detail workshop sessions, although we have done something like that in the previous setting.

Today, we elected to join two subjects recognizing there is some disparity. On the other hand, I mentioned earlier that perhaps joining maintenance and medicine might not be a bad idea. If you look at me and my size and shape and things like that, I've got some things to learn about maintenance. But the subjects, though separate here at the Aeronautical Center with this wonderful facility, provide an ideal opportunity to cover both the aviation medicine side of the human factors issue as well as the maintenance side.

Again, I do not want to take a lot of time. If I can get through in a hurry we can get quickly to the work of the workshops. I challenge you to present everything you can to us. Now let me tell you what we want to do with everything that you present to use.

Some time back we decided that we would have an oversight group for what we call, "human factors," that I would probably chair that group, and that we would have full representation from within the FAA and the National Aeronautics and Space Administration (NASA) and the Department of Defense (DOD), essentially an all-government oversight group.

That oversight group would receive the benefit of the input on all of these workshops and their representation of what is being done in NASA, in FAA and in DOT. Now, if there's something that is not being done which has been presented to us, then obviously we want to show that and show where it would fit in the structure or a reason for not doing it if that's the case; or,

perhaps at a minimum, the prioritization of the work effort in the human factors area for everyone in the government who is involved in aviation human factors work.

The task force that we have established in FAA consists of representatives from all of the organizations who have been arduously pouring over the details of all of the workshops that we've held and will also follow on this workshop to do the same thing.

I hope to bring together the steering group as quickly as I can with the objective of developing a representative program in September. If I can bring the oversight group together -- and let me tell you the constituents: I will be chairman of the steering group, which will include A.P. Albrecht, the Associate Administrator for Engineering Development at the FAA, and James Costantino, the Director of the Transportation Systems Center, as well as representatives from the Department of Defense and NASA and the Associate Administrator for Air Traffic and Airways Facilities at the FAA.

Externally I have not yet asked or had a determination from NASA. I expect to do that in the next couple of weeks. There will be a new associate administrator coming in.

That is where our request will be levied. And from DOD, frankly, we have not asked yet for participation on the oversight group and basically the reason for that was we were waiting for the output on the task force study. The Presidential commission, now that we have that in hand, my guess is I will probably go to General Howard Leaf and ask for a suggestion from him as to an oversight participant.

So that is the constituency of the group. There have been some suggestions that perhaps we should call on a couple of outside generic organization representatives -- perhaps the National Research Council or perhaps the Flight Safety Foundation, and that's still under consideration.

At any rate, as quickly as I can pull that group together and as quickly as Guice Tinsley and Cliff Hay can pull together the information that has been acquired here and present it to that group, I will do so.

We will then follow up with, time permitting, a listing session where we call selected Washington organizations together, present what we have found

and ask for any input: Have we missed anything that was intended to be presented in all of these workshops? And from that session, I would expect to lay over the existing programs the areas of activities identified through the workshops and again try to structure a program which addresses as many of the issues as we can within the resources available to us.

And as I said, in September you folks will know exactly what we intend to do in the program. Obviously, we will remain open to comment on a continuing basis. I would expect then after we initiate such a program, or restructure our existing programs as appropriate, that we will be coming back periodically to report progress, and during that entire period of work and whatever that time frame turns out to be, the oversight group will have some purview over the activity.

The intent is, we want to respond to the community's requirements and we want to do it in a responsible way. So we need you, we need your input, we need your participation and I ask that you give it freely.

Thank you again for being here. I appreciate your taking time from your busy schedules and thank you again for hosting us. Thank you very much.

MR. DEMPS: Dr. Dille, Chief of the Civil Aeromedical Institute, will say a few words and after his talk with you, we'll be breaking out to our sessions.

DR. DILLE: Although of limited interest to those of you attending the maintenance workshop, I would like to welcome all of you to the Civil Aeromedical Institute, or CAMI. The Aviation Medical Development Center was established as a part of the Aeronautical Center in 1946, 35 years ago.

While that name did not stick (it was changed the following year and several times in ensuing years) there has been a continuity of programs, and until recently even a continuity of some of our staff members.

We have, just for this meeting, come up with a 20-year cumulative index of research reports from here. It is in the jacket of those attending the biomedical workshop. If there's anyone attending the maintenance workshop who would like a copy, you can obtain one on request.

We also, subject to availability of them, have individual copies of research reports that you can obtain from us this week and either pick up or have mailed to you.

Also if any of you attending the maintenance workshop have any specific areas of CAMI you'd like to visit, please let us know this evening at the social hour, at lunchtime, or sometime today.

We have no general tour for all attendees that has been set up at this time. CAMI's been involved in, and its predecessor, CARI, Civil Aeromedical Research Institute, has been involved in aircraft accident investigation for the last 20 years and we feel this is perhaps the best method of identifying possible aviation safety problems.

The medical certification branch of CAMI processes over 500,000 applications for airman medical certificates each year. We get enough questions raised in that program alone to keep our staff busy answering the questions that are asked on different medical conditions, and different medications that come on the scene.

We have in that program a huge data base that contains, for example, over 5,000 monocular, or one-eyed pilots and this is more active one-eyed pilots than most of the countries in the world have total pilots.

We have been able to analyze this data base for a number of things, including accident rates for various physical defects, and for guidance on the frequency and content of physical exams; others have attempted to identify pesticide-related cancer and stress in air traffic controllers.

Occupational-related accident rates of physicians are a favorite target in that latter type of study. We also receive in CAMI the medical portion of accident investigation reports. Those of you working in cabin safety are familiar with Donell Pollard's data base and her cabin safety workshops.

We have an industrial hygiene program that's active now with asbestos, PCBs, headset test tones and other noise complaints. There's an education program for both physicians and airmen which includes medical seminars for our 8,200 designated physicians, an accident investigation course for medical officers, and also in conjunction with the Air Force, the Navy, NASA and soon the Army, an active physiological training program for civil aviation personnel which ranges from free to twenty dollars in cost.

So I wanted to let you in a little bit about what CAMI does, and if we can answer any of your questions while you're here, please contact any

of our staff. I think they're fairly liberally sprinkled among your attendees.

(RECESS)

DR. DILLE: The primary purpose of the workshop is for you to tell us what the critical human factors issues and biomedical human factors areas are and thereby help us assign priority for our work.

We are not requesting additional resources and not asking you to help justify the same. We will, as promised, spend one and a half days listening to you; but you were warned in your letter from Mr. Demps, a letter of invitation, that first we were going to tell you about some of our past accomplishments and some of our current activities as a basis for the discussions which will follow, particularly tomorrow and into Thursday morning.

Our first speaker on this session of FAA presentations is our Federal Air Surgeon, Dr. H.L. Reighard, from Washington, D.C.

DR. REIGHARD: Thank you, Bob. Good morning. I'm going to make a few remarks by way of background relating to civil aviation medicine efforts in the human factors area on the part of the Federal government.

I will talk a little bit about the history of biomedical and behavioral factors efforts. I will list some of the accomplishments of FAA civil aviation medicine research and then I will talk briefly about some of the things I see as still needing to be done into the future.

I don't expect that I will make any particular revelations to you; rather, I would like to give an overview with regard to what we have viewed, and what we do view in the future as significant in this particular specialized field.

I would imagine at this point that a great deal of the work that came to have a civilian flavor had some of its origins in the military field. Aviation medicine, as a matter of fact, started with military efforts and I will mention that briefly in my comments on the history. We are fortunate today to have with us an outstanding spokesman for the military aviation medical research effort, Colonel George Mohr, the commanding officer of the Aeromedical Research Institute of Wright-Patterson Air Force Base. He will be speaking to you later.

I guess the first physician to fly was Dr. John Jeffries. He was in a balloon that traversed the English Channel in 1785 and I'm told -- I can't corroborate this -- that the pilot of the balloon midway considered having to jettison Dr. Jeffries because he was losing lift. The only way the pilot felt that he would make it across was to get rid of his "baggage" and this probably started the struggle which has existed between medical people and airmen and engineers and physicists and so on throughout the history of aviation medicine.

By 1875, the first life support equipment was in use. This was probably the oxygen equipment that was used throughout the 1800's, with balloon flights. The first aviation medical examinations were given to U.S. Army and Navy aviation personnel in 1912.

Early in World War I, England concluded that about 90 percent of her casualties in aviation operations were due to, quote "human factors." It was their determination, after accident investigations and attempts to reconstruct circumstances surrounding selected accidents, that there should be some kind of medical requirements for aviators. They did institute such a program and the casualty rate was reduced significantly, and attributed to the fact that there were specific criteria for the selection of those people who flew. The U.S. adopted many of the British specifications for aviators when it entered the war in 1917.

Now, the civilian part of aviation really came into being, as far as a coherent effort to regulate and provide specifications, with the passage of the Air Commerce Act of 1926. And by the end of December, 1926, a set of medical standards had been developed by the first Chief of Civil Aviation Medicine, Dr. Louis Bauer.

Those standards were in part, as you would imagine, fashioned after the existing military medical standards. The focus was primarily on special senses, vision and hearing. Dr. Bauer set up a system for the application of medical standards.

He chose to go the route of designating private persons to assist in the medical assessment and created a core of designated aviation medical examiners. This system was implemented in 1927 and was fully operational at least by the early 1930's.

The 30's saw some other significant developments relating to human factors. One was the establishment of a maximum flying hours per month rule for airline pilots. The first biomedical research effort was established in 1935 by the U.S. National Bureau of Standards, and a special committee for aviation medicine was established in 1936.

The CAA, Civil Aeronautics Administration, predecessor to the FAA, established a medical science station in Kansas City at one of their regional offices. This was the first U.S. Government civil aviation medical research facility.

In the early 40's, a good bit of the civil aviation medicine effort was applied to the beefing up of the United States' potential to support the growing military effort. The so-called "Civilian Pilot Training" program pre-occupied the CAA not just in medical, but in other areas as well. Around the mid-40's, physical requirements for air traffic control tower operators were also established.

As Dr. Dille indicated, the Civil Aeromedical Research Laboratory, called by another name, was established here in Oklahoma City in 1946 at the then existing Aeronautical Center. It was moved to Ohio State University in 1955 and back to Oklahoma City in 1958. It was then called the Civil Aeromedical Research Institute. In 1965 it was joined with three other divisions of the Office of the Civil Air Surgeon and became the Civil Aeromedical Institute as it's called now.

During the period of the 50's, some of the changes that occurred included specific research on medical standards for aviators and air traffic controllers, and the development of crashworthiness criteria as the result of the impact research done here.

The Office of the Civil Air Surgeon was established in 1959, now called the Office of Aviation Medicine. The age 60 rule for airline pilots was promulgated in 1959. This all coincided with the creation of the Federal Aviation Agency, now Administration. We also had the first major revision of the medical standards since those established by Dr. Bauer in 1926. In 1959 we established specific standards for the major diseases of significance to civil aviation medicine.

Beginning around 1960 and continuing, the FAA has established medical activities in the area of accident investigation, airmen and AME (aviation medical examiner) education, aircraft hijacking inputs and a number of other fields.

Now if I may, I'd like to turn from some of the historical considerations to a simple listing of some of the accomplishments, mostly in research. They will be just that, a listing. I will leave it to the CAMI scientists who will follow me to develop these matters further.

We, the researchers and scientists, have been significantly involved in the development of specifications for energy-absorbant seats, the development of criteria for aircraft evacuation, evaluating and developing specifications for protective breathing equipment. We have had numerous consultations with various companies in the aviation industry with regard to a wide variety of human factors problems. The evaluation of toxicity relating to the thermal decomposition of cabin interior materials, evaluating and testing flotation devices, the development of defenses against hijacking, including the development of a screening profile and a strategy for managing a hijacking event while in progress, developing a special evacuation means and procedures for specific groups of people such as handicapped and so on.

One quite significant development, which is an ongoing effort, has to do with developing selection criteria for air traffic controllers. We are just about to complete and forward a final packet to the Office of Personnel Management, for a totally revised controller selection battery that has been developed over the last eight to ten years, which, by its precision of selection, is expected to save as much as \$3 million annually because of the reduction of the failure rate in training and later on the job.

Scientists here at CAMI developed information which permitted the Agency to write specifications relating to ozone exposure in certain aircraft operations. The toxicology laboratory and its work will be discussed in more detail by Dr. Kirkham. We do have some continuing activity, which is very important, as referred to by Dr. Dille. That is the accumulation of incidents relating to accidents in terms of autopsy information and toxicological material analyses.



I would also like to point out briefly some areas that I feel should be cause for continuing interest and in some cases concern. I believe we, in the Agency, working with the industry, have an obligation to ensure the systematic identification of requirements for future biomedical and behavioral research.

I think we need to set them down in writing, as Walt Luffsey has indicated. We need to have the benefit of the input of you folks from the industry and by academic institutions.

We may be doing in the future some further work relating to pilot aging. I say, "We may be." I'd like to give a brief background on that.

Five days ago the panel, which was put together by the National Institute on Aging to review a prior report from the Institute of Medicine of the National Academy of Sciences, submitted its final draft report.

The report contained three recommendations: one, that the present age 60 rule be retained; two, that a systematic effort be initiated to accumulate data that might in the future be used to consider modifications of the "arbitrary but necessary" age 60 rule; and the third recommendation was that the age 60 rule should also be applied to part 135 operations.

And I say we may be doing studies for the reason that, in the body of the report of the panel, there is a suggested approach of using actual airline pilots as subjects. This is an approach to obtaining the necessary data which might lead to consideration of granting exemptions to the age 60 rule.

This is a draft report. It is to be further commented on by the panel members and analyzed by the National Institutes of Health. Whether or not this suggested approach is taken, remains to be seen.

We need to do further work on screening of aviators and air traffic controllers. We have already initiated an analytical study to look at the frequency of examination for airmen and air traffic controllers.

We'll have to look at the evolving technology in aviation, particularly with regard to increasing automation in the cockpit and the air traffic controller system. Considerable work has already been initiated here at CAMI in those areas.

We will have to be alert to the occurrence of new hijacking phenomena or terrorist phenomena and be prepared to respond in a biomedical or behavioral science fashion to those.

Although difficult and perhaps impossible, it is our intent to take a look at the factor of pilot judgment, that thing that's almost immeasurable and may continue to be immeasurable. It is universally believed that where so-called pilot error is concerned, the matter of judgment appears to be the factor most commonly involved. Not intelligence, not skill, but the decisions, sometimes poor, that are made in the face of circumstances encountered by aviators.

We will attempt to take a look at this to see if anything can be done, hopefully, to improve this situation whereby aviator judgment is involved in the support of safety of operations.

We, in the medical field, strongly support the need for accumulating data and providing the degree of sophistication and analysis that is required to understand the contribution of various factors to safety and to accident causation. And this is an important continuing need that will have to be worked on very assiduously in the future if we are to take a rational approach in problem solving in the aviation setting.

In summary and conclusion, I feel that there is a need to build on the evolving spirit of cooperation among the biomedical and behavioral scientists, other government elements and industry. I think we will all benefit and the public safety will benefit from that continuing effort. Thank you very much.

DR. DILLE: Thank you, Dr. Reighard. Our next speaker is Bill Kirkham, a forensic pathologist and Chief of our Aviation Toxicology Laboratory at CAMI, and Bill's topic is, "What does medical investigation of aircraft accidents reveal?"

DR. KIRKHAM: Thank you, Dr. Dille. It's good to see a lot of familiar faces in this group. I hope that in the workshops we will have an opportunity to visit in more detail, particularly those of you who are attending the workshop on accident investigation.

Accidents represent perturbations in the aviation system, which we all wish would operate without error. They are experiments in nature, and as such

give us an opportunity to study errors or mishaps with a goal of correcting safety deficiencies which may have caused the accident.

Now, if I may have the first slide, please. The National Transportation Safety Board investigates accidents mainly to determine the cause and identify certain safety problems.

The NTSB, with limited staff for the most part, handles large aircraft accidents and fatal general aviation accidents. The Federal Aviation Administration investigates accidents to determine if regulatory functions are involved, if the Federal Aviation regulations are adequate, and if there has been a violation of the Federal Aviation regulations.

Nonfatal general aviation accidents, by far the greatest number of accidents, are investigated by the FAA. Even though the National Transportation Safety Board (NTSB) has human factors investigators, they have little if any in-house medical support.

Because of this, the FAA by agreement supports the NTSB through its regional personnel and aviation medical examiners, as it can, with some medical pathology and laboratory services.

This help is primarily in obtaining autopsies and toxicology specimens on crew in general aviation accidents, and by direct participation with NTSB safety, the human factors group in major air carrier accidents.

Civil Aeromedical Institute personnel, as part of the research activities, have participated in the aircraft accident investigations for some 20 years. The rationale for this has been to identify problems that may occur, problems which may point to areas which need laboratory research, or to modifications that could be made to improve aviation.

In these activities, CAMI personnel participated in almost all major air carrier accidents in the United States and in many selected general aviation accidents.

Now, what can we learn by studying accidents and investigating accidents? Well, one of the things that we learn, and the easiest thing, is to correlate crash injuries with what happens during the impact, and this focuses our attention on restraint functions because, although the accident is not prevented, we can possibly restrain the individual so as to possibly diminish the injuries that he would receive.

And I'm going to show you a series of slides for the rest of my presentation and obviously this can only be a panoramic overview of what we might find in an accident investigation.

Now, we know by dynamic study, impact studies, that the human body will flail forward if unrestrained. This is sort of a composite of 11 general aviation aircraft cabins, and we see serious injuries to the head and chest and flailing of the legs. And this is an artist's drawing of the type of thing that we very frequently see in accidents that are at the level that the human body can perhaps tolerate.

Fortunately in the last two, two and a half, three years we've had a requirement that all new manufactured airplanes have a shoulder harness placed in the front two seats, and that the people flying those aircraft use their shoulder harnesses on take-offs and landings which we hope will avoid some of this.

To show you the type of correlations that can be made by medical people at an accident scene, here's a young man who died as a result of a puncture wound in the chest. Now, the medically oriented person will ask the question, Why did he get this puncture wound? How did he get the puncture wound when the fellow in the left front seat, the pilot, walks away from this accident?

His buddy is dead in the right front seat. Now, the pilot came forward against this yolk, and you'll notice the breaking pattern here, and the fellow who died came forward against this yolk, and notice the breaking pattern of the yolk there.

There was some brown discoloration on the end of this which, under the microscope, revealed red blood cells, muscle and skin. And there's no question that this was the spike that penetrated the fellow's chest and he lost his life as a result of that.

This is the type of crash injury correlation that can be made by medical personnel investigating accidents. Now, we can see this duplicated. This is a slide from one of the impact studies of a dummy seated in a Beech cabin here on the impact track and notice how the body comes forward, chest against the yolk, possibly breaking all the ribs, possibly bursting the heart, and the head coming into the panel inflicting very severe injuries.

A shoulder restraint can go a long way to reducing the type of injuries that are received. And some of the past research at CAMI has developed tolerances to impacts, and these levels of 80 G's and 200 G's and 30 G's and 50 G's and so forth are very high in terms of survivability. Actually the aircraft structure in many instances will fail before the human body will fail if the individual is properly restrained.

Now, we see also in accident investigation that part of our restraint systems may not be functioning properly, and it behooves us to look at the way people are restrained. And here we see an inertia reel that in an accident failed, so this was the weakest part of the restraint system.

And the seat is an integral part of the restraint system.

And if you have a seat that will break as this seat did, you see, it affords less than optimum protection to the individual because he may receive very severe injuries on a secondary impact when a seat like this will break suddenly.

And so one area of accident investigation is to look at seats and look at seating configuration. Here the individual sits over the main spar, and there is very little attenuation of vertical impact forces in this type of seat configuration.

We had thought for a long time that our air carrier seats worked very well, but an accident like this, in which the left gear collapsed, led to a number of seats breaking over into the aisle and this type of separation of a seat leg from the seat pan in a relatively minor air carrier accident.

These are the types of observations that medical investigators can make. Now, Mr. Chandler is going to talk to you more specifically about seat functions and seat testing.

Here's a recent accident, a relatively low-level accident, I would estimate. Notice that the seats are broken over toward the aisle. And again, notice that the seat legs here failed rather markedly for the degree or type of accident. One of the easy things to do is to make crash injury correlations and look at restraint systems and how they protect the occupants.

Another thing we can do is look at postcrash factors. You can survive the impact, but die in the post-crash situation, a fire, drowning, exposure, toxins and perhaps any number of things.

An old accident here, you see, we've had the fuel misted here, ingested in the engines. The fire ball has gone off and the people are trying to make their egress at the time this picture was taken.

And an investigation of the postcrash situation revealed that those people sitting in rows 12, 13 and 14 were found -- their bodies were found here as they tried to exit out the right rear exit. This exit was closed. They did not go forward, and these individuals appeared to have been queued up in the line waiting to get out of the aircraft.

They were overcome by the toxic gases and they had very high levels of carbon monoxide in their blood. This was a medical investigation that was done by CAMI and such a report is available to you if you'd like to see that egress from the burning aircraft.

Another accident that occurred in Anchorage. Prior to this accident, we suspected that the carbon monoxide levels were not high enough in certain accident victims to really incapacitate them.

So Dr. Crane apparently suggested that we also look for cyanide, hydrogen cyanide, in those accident victims and this was the first one. These are carbon monoxide levels here. This is an incapacitating level and this is a lethal level and those are hydrogen cyanide levels.

And a number of these accident victims had hydrogen cyanide in their system - and Dr. Crane is going to talk to you about where we stand in terms of toxicity testing on some of the interior materials - but this led us to suspect that the interior materials did indeed contribute to the toxicity of that environment. And here the DC10 at Los Angeles is a prime example of the type of situation that we'd sure like to avoid.

We'd like to prevent this. We'd like to get those people out. The interior materials here did not burn, but they did give off gas. None of the individuals were impaired in their egress from the aircraft, but the firemen who came in there after the accident after all the people were out, to make sure that they were out, collapsed, overcome by those toxic gases.

And so it behooves us to define what that toxic load is here and to alter these materials if possible. This all comes from correlating certain accident investigations with certain research work.

Another thing we can do is to identify toxic factors that may be operational on the crew. Because of some delays in processing specimens by another laboratory that we used, some 13 years ago a small forensic toxicology unit was set up in the Civil Aeromedical Institute, and we put together a box like this.

It's called a tox box. This tox box is distributed all over the country and it appears at an accident scene and a pathologist can use this to collect specimens that can be sent in to the laboratory to analyze for various toxic materials.

This operation is run by actually three people in our laboratory and we get specimens from about 65 to 70 percent of the pilots who are killed in aircraft accidents.

One of the areas that is important is this whole business of air application. These people who apply chemicals to our crops and so forth are subjected to the toxicity of those materials that they apply. And one can follow them over the course of the year and they do develop a chronic toxicity.

I can't say that that really occurs in the pilots. We don't have those kinds of studies. These are pesticide applicators. Eight hundred and forty-nine pesticide applicators were studied for a full year, and you can see that the cholinesterase, a very important constituent in their system, does decrease over a period of time. And so aerial applicators are subjected to the same types of toxicity, and through the years we have provided a medical advisory service to aviation physicians or aviation medical examiners who may handle these people who are subjected to the toxic effects of the pesticides.

Alcohol has been identified as a significant problem. Over the years 8.5 percent of the pilots in fatal accidents have blood alcohol levels at the level that would impair their function.

Drugs: we see individuals who take drugs. 4.2 percent, in recent years, of those pilots who are killed have some association with drugs or narcotics.

Physiologic factors - you can be overcome by G forces. This young fellow was doing aerobatics - overcome by G forces. Over the weekend we had two accidents, aerobatic accidents that appear to possibly have been related to pilot incapacitation - one here outside of Oklahoma City and one in San Angelo, Texas.

Another very important area is with this problem of spatial disorientation. Here is a piece of an airplane found half a mile or a mile away from the rest of the fuselage - in-flight break-up.

When we see this type of thing, and if there's an overcast or something like that, we wonder about this problem of spatial disorientation. If you look at the cause factors of fatal accidents in the NTSB reports, you will see that continued VFR flight into adverse weather conditions and spatial disorientation are part and parcel of the same problem, are number two, number two in the cause of fatal aircraft accidents. It's very difficult to get at this. This is something we need to train around to prevent.

Medical conditions in crews - we can try to elaborate on this by doing autopsies and examinations on the pilot. And the pilot who was in a crash down here in Ardmore, Oklahoma, which killed 83 people, had very severe coronary artery disease. He did not disclose this fact that he had pain and was on medication.

He did not disclose this to his aviation medical examiner, and so we monitor the medical certification procedure by investigating accidents and doing the medical portion of them.

And the last area, as I have outlined in here, is very difficult to get at, and Dr. Reighard pointed this out. This is the business of pilot judgment, planning for flight crew coordination. Actually crew/air traffic coordination might be named here. Cockpit discipline, attentiveness of the crew, this is an area that's very difficult and it behooves us to concentrate more on this because this is the cause of many of our accidents, such as the world's worst tragedy that occurred in Tenerife.

The problem of the communication from tower to cockpit, the problem of communication within the cockpit that allowed this tail-end plane to take off in the fog with reduced visibility with the Pan Am plane on the runway.

That's a human factors accident. That's not an airworthiness accident. It's an operation, human factors type of problem.

And what about this one, the 727 over San Diego, what kind of an accident is that? That's a cockpit attentiveness, ATC communication type accident. It is very difficult for us as accident investigators to get at the specifics of this type of thing.



So that when we look at the NTSB statistics that show that between 85 to 90 percent of our aircraft accidents are caused by something in the pilot, it behooves us as medically oriented people to look at those human factors components that we can address to see if we can find out what's causing these accidents specifically, and feed this back into the system to do some prevention. Thank you.

DR. DILLE: Thank you, Dr. Kirkham. The next presentation is on passenger seat performance by Richard F. Chandler, Chief Protection and Survival Laboratory.

MR. CHANDLER: Thank you, Dr. Dille. You've just heard Bill Kirkham go through a synopsis of the work done in field investigation of aircraft accidents. Such work is one of the ways we learn what our problems are.

Among the slides he showed you were slides depicting the performance of passenger seats.

The performance of air carrier passenger and general aviation seats during a crash has been sporadically investigated since the 1950's. Most of these investigations used simple linear spring mass dynamic theory to evaluate the theoretical performance of the seat and restraint system under short duration crash loads, but provided very limited test data to support their conclusions.

More recently it has been recognized that the simple linear dynamic model is an inadequate tool for any but the most rudimentary studies, and more complex models have been developed.

In particular, the FAA has developed the Seat-Occupant Model for Light Aircraft which provides a nonlinear finite element model for describing the seat and restraint system and an 11 mass model of the occupant with beam-column simulation of the lumbar spine and the neck.

This model is now in final validation, and appears to represent the single occupant light aircraft seat with reasonable fidelity.

To evaluate the application of these models to transport aircraft passenger seats, the Civil Aeromedical Institute has undertaken a program to obtain baseline performance data for a variety of passenger seats under carefully controlled laboratory conditions which simulate the crash loading

conditions. This test program began in February of 1981 and is scheduled to be completed in December.

Since the work is not complete, it would be premature to present final results or conclusions at this meeting. Instead, I would like to outline the scope of the program, and to present some observations and problems which are apparent at this time.

Because the current regulatory requirements are based on static loading conditions, we started our program with a simple static test similar to that described in the Technical Standard Order for passenger seats. This slide shows the test arrangement which we used. The seats are mounted on our test sled, just as we would for a dynamic test.

A six degree of freedom load cell is placed under each leg of the seat to measure the forces and moments at the attachment points of the seat to the aircraft floor. The aircraft floor is simulated by a fixture, described in the Crash Survival Design Guide, which allows the floor to be deformed to approximate the distortion which may occur due to external forces in a crash.

Thus we have two test conditions possible here, one with floor deformation, one without. The loads are applied through the pulley system to equalize the loads in all seat positions even if deformation varies.

Load cells in the link to the body block measure the load at each position.

Some typical observations are indicated in this slide, where post-test position of the body blocks are shown, together with the failure at the lap belt which was the end point for this test.

If we remove the seat cushions, we see that the rigid body blocks have loaded the leading edge of the seat pan, causing them to bend downward until the body blocks contact the seat legs, which then carry the load directly.

This is an artificial loading condition that is not representative of either field observations or dynamic test experience. This seems to confirm observations by others that this static test procedure is not representative of occupant loading of the passenger seat.

Even if the leading edge of the seat pan were of more substantial structure, it would only form a fulcrum for the rigid body block, a different

loading condition, but not more representative of the occupant.

Here we see a failure of a lap belt with a rated strength of 2,000 pounds, considerably above the minimum requirement of 1,500 pounds. Failure of 2,000 pound rated strength lap belts were a frequent end point to our tests, so much so that we have begun replacing all 2,000 pound belts with 3,000 pound belts in order to increase the chance of failure in the seat structure.

For our dynamic tests we use a similar seat installation, but with 50th percentile anthropomorphic dummies as seat occupants. In addition to the two test conditions previously described, we add a third variable shown in the slide; a combination of forward and side loading produced by yawing the seat 30 degrees to the side. The sled test facility at CAMI allows us to control both the impact velocity and deceleration acting on the sled.

For these tests we chose a roughly trapezoidal crash pulse, with a fairly short rise time as shown in the slide. We began testing each seat assembly at 6 G, and then increased the G level by 3 G increments, using an untested seat assembly, on subsequent tests until structural failure was observed. The impact velocity, represented by the area under the curve on the slide, was high enough to assure that failure would occur during the test pulse. In this test, failure occurred at about 180 milliseconds.

Here we see the load measured at the right rear leg, where the failure occurred, and the failure point is more obvious. Knowing the failure point, we can easily calculate the impact velocity required to produce the failure, an important point for future test planning.

It is well to remember that even though aircraft may crash at higher velocities than we are testing, any velocity greater than required to produce failure in the seat will contribute no information pertinent to the seat performance.

Now, let's look at a few more examples of failure points, and let's start with the exception to the common results, shown here.

This seat failed by general deformation of the basic seat structure until spot welds holding the basic structure together let go. This is the only seat in our program which failed in this manner, the other failures being associated with fittings such as a lap belt tie down fitting and an aft leg attachment fitting.

An aft leg tension link failed at the eye of the bolt attachment to the seat.

Seat tie down buttons which fit into the floor track... this failure was the result of floor deformation, which caused the buttons to bear on the side of the track, together with a rigid leg structure which would not deform to allow the buttons to bear evenly across the track.

A comparable failure occurring on the floor track.

One of the test conditions which I haven't mentioned is illustrated by this slide, an overhead view of a test with passengers seated behind the test seat. We are doing these tests to evaluate the effectiveness of the "brace for impact" position as well as to measure the loading on the seat.

These tests seem to substantiate earlier tests which show the value of the brace position... injury criteria can be reduced by about 50 percent, but also have indicated a "size effect" on injury potential for the unbraced occupant.

Here, the smaller passenger, a 5th percentile female dummy has cleared the seat in front of her, while the 50th percentile dummy and 95th percentile dummies sustain greater head impacts with the seat back.

This may have even greater significance as seat pitch becomes closer, making all passengers, in effect, a larger percentile size.

In conclusion, I would like to summarize some observations made so far in the program, but please keep in mind that the program is not yet over.

All seats exceeded the minimum requirement for forward static loading by 5 to 35 percent.

Two seats, of ten tested, failed during application of floor deformation, without any other loading.

Although there is a wide variation in the data, the mean lap belt loop loads measured in these dynamic tests would indicate that the minimum static load required by regulation, 1,530 pounds, would occur in a dynamic test condition of about 3.6 G.

Failure of lap belts rated at 2,000 pounds commonly occurred before seat or track failure.

Three of four seats dynamically tested in the forward condition withstood 9 G.

Zero of two seats dynamically tested in the forward condition withstood 6 G if concurrently stressed by floor deformation.

Three of six seats tested with 30 degrees yaw withstood 6 G in dynamic tests. None withstood 9 G.

One of two seats tested with 30 degrees yaw and floor deformation withstood 6 G. None withstood 9 G.

The sequence of failure is difficult to determine without appropriate instrumentation.

Dynamic loads at time of failure are generally greater than static loads at time of failure.

Thank you.

DR. DILLE: Thank you, Mr. Chandler. Our next presentation will be by Charles R. Crane, Ph.D., Biochemist, Aviation Toxicology Laboratory, Civil Aeromedical Institute, on understanding the fundamentals of smoke toxicity in aviation.

DR. CRANE: Thank you, Dr. Dille. Ladies and gentlemen, I'm going to give a fairly brief summary on this topic because it is really composed of so many detailed small items that to discuss one in detail would be rather boring.

To discuss very many of them adequately would take much too long.

In the early 1960's many people in the aviation environment became aware for the first time of the possible significance to survival of postcrash fires. It was first observed that some victims with no impact-related physical injuries died as a result of the ensuing fire. So the questions arose: What killed them? How did they act? If we could answer those questions, then how might we reduce the risk of injury or death in the post crash fire situation, particularly with reference to toxicity?

Our forensic toxicology unit found that such victims invariably presented an elevated blood carboxyhemoglobin (COHb) concentration, indicating inhalation of CO from the fire.

In early 1969, the Biochemistry Research Unit became interested in the observation that such COHb values ranged anywhere from 35 to 85 percent saturation. The obvious questions were: What is the minimal lethal COHb value? and if CO inhalation wasn't responsible for the deaths of those victims with levels below the minimum lethal concentration, then what did they die of?

There was a possibility that the some of the reported COHb values were in error due to inadequate analysis; so our unit initiated an evaluation of the common analytical techniques used by forensic toxicology laboratories.

We found that for postmortem analysis under any but ideal conditions, the commonly-used colorimetric procedures could introduce considerable error.

We further found that only gas chromatographic techniques were reliable and recommended that they be utilized exclusively for COHb analysis of blood from fire victims. Gas chromatographic techniques are now used in most laboratories.

We recongized further that toxic gases other than CO are present in smoke, and that if CO alone wasn't responsible for the death of fire victims, possibly it was due to the combined toxicity of several gases.

Knowing that cyanide is a toxic gas that had been shown to be present in smoke from other sources, we proposed that HCN could be a factor in the death of postcrash fire victims.

We therefore suggested that blood cyanide analysis be included in the routine postmortem toxicological examinations.

In late 1970 there was an impact-survivable accident in Alaska that involved postcrash fire, and for the first time aircraft fire victims were shown to have elevated blood cyanide levels in addition to elevated COHb levels.

However, we were still unable to answer the specific question, Are the demonstrated levels of CO and HCN together adequate to explain the cause of death?

So, in 1971 we initiated a program that has continued to date; elements of that program are to: identify those toxic components of smoke that contribute significantly to the overall toxicity of smoke; define experimentally the

dose/response relationship for each of these components, both singly and in suitable combinations where the response measured is related to one's ability to escape from a fire environment; devise a small-scale test method for burning materials and measuring the toxicity of the smoke where both the generation of the smoke and the evaluation of its toxicity are relevant to the environment of real fires; justify or validate the use of experimental animals to gather data that will be used to predict effects of humans; and finally, come to a decision concerning the best way to improve passenger survival time in the fire environment, taking into account such relevant factors as the real magnitude of the risks associated with the fire hazard, how much improvement can be achieved and at what cost.

Also what degree of importance should be placed on such properties of materials as durability, comfort, aesthetics, etc.

Along the way, we must not lose sight of the possibility that the risk of postcrash fire deaths from smoke toxicity may not be realistically reduced by controlling cabin interior materials. Furthermore, we should make everyone aware that the risk today is really a surprisingly small one, anyway.

If no one died from toxic smoke inhalation in postcrash fires after today, we would save, statistically, 10 to 15 lives per year, according to the best estimates we have.

So, since 1970, in our laboratory we have: designed a small-scale animal toxicity test system that allows us to measure the time-to-incapacitation and time-to-death for rats exposed to atmospheres of smoke from real materials or to synthetic atmospheres composed of known gases; determined the incapacitating and lethal doses in rats of three systematically toxic gases -- CO, HCN and H<sub>2</sub>S -- and of two irritant toxic gases -- HCL and acrolein; devised for the first time a generalized model and equation that relates an animal's body weight and respiration rate to time to incapacitation and time to death as a function of the concentration of any one, or any combination, of the systemic toxic gases; demonstrated that for systemic toxic gases, at least, the dose/response relationships derived from animal experiments can be used to calculate dose/response relationships for humans; compared in our system the relative toxicity of the thermal decomposition products of well over one hundred polymeric materials -- natural and synthetic; determined the incapacitating and lethal heat loads for rats/mice,

and developed an equation that will predict incapacitation and death for rats or humans exposed to any given air temperature; participated in the efforts of several organizations to evaluate the smoke toxicity problem and/or develop appropriate methodologies: The American Society of Testing and Materials (ASTM), National Bureau of Standards (NBS) committees and Special Aviation Fire and Explosion Reduction (SAFER) committees.

I realize this was a lot of words without really giving you much details. At any time you are free, feel welcome to drop around our laboratory or talk with me in the halls and I'll be glad to give you all the information I can. Thank you.

DR. DILLE: Thank you, Charles.

#### RECESS

DR. DILLE: The first presentation in this session will be an analysis of protective breathing systems intended for use aboard transport category aircraft by Don DeSteiguer.

MR. DeSTEIGUER: Thank you, Dr. Dille. First slide, please. On November the 3rd, 1973, the Pan American Boeing 707, following an in-flight fire, impacted into the end of the runway at Boston's Logan. The investigation of that accident, among other things, questioned the functioning, or nonfunctioning, of the protective breathing equipment that was provided aboard the aircraft.

If we look at the protective breathing equipment, we find we have generally two types carried aboard our transport category aircraft. The first is a two-piece device which makes use of the quick-don oxygen mask, which is already there and connected for use in the event of a decompression.

This, of course, gives respiratory protection. Facial protection is then obtained through the use of the supplementary goggles. The other protective breathing device on the flight deck is a full-face mask which is normally coupled to a portable cylinder, allowing one of the crew members to go back into the aircraft for examination, firefighting, what have you.

Due to the questions which were raised in the Boston Pan Am accident, we were requested to develop a testing program and to evaluate those items of



protective breathing equipment which were currently in use in the commercial air fleet.

The method which we established, rather than trying to rely on a subject telling us whether they think they smelled something or not, was based on a quantitative procedure where we get actual analytical data as to whether the equipment is functioning and how well the equipment is functioning.

Very briefly, the procedure is to put the equipment on the subject. We hook sample tubes to the equipment and then we challenge that equipment with approximately 100 parts per million of normal pentane.

Normal pentane being selected because of its nonirritating and nontoxic properties at those levels. We then pulled the gas samples through and into a gaschromatograph which in turn gives us an analytical measurement of the amount of normal pentane which the equipment is being challenged with and the amount of normal pentane which might be penetrating into the equipment.

A typical data recording which we obtained is such -- the pass and fail points are across the bottom, the lower dotted line represents the pass-fail point for the respiratory system or the oxygen mask of the two system components.

The other, or the higher dotted line, represents the pass-fail point for the visual system, or for the goggles. If it is a one-piece system where both the visual and respiratory systems are in one compartment, then the lower line is the pass-fail point.

Now, what we generally found was that the oxygen mask itself functioned quite well. In this case, there was no penetration of any kind into the mask; but when we look at the goggles, we find they fail immediately and totally.

They were more of a hindrance than a help. The crew members would be better off never to put them on. We received for testing 137 different kinds of protective breathing devices which were currently in use in our air carrier fleet.

Of the 137 which we tested, 115 did not pass the test procedure. The remaining 22, though they may have passed the contaminant protection, had additional problems such as those encountered in donning, peripheral vision, things of that type.

The test procedure did validate one concept and that was the concept of venting the goggles in order to keep them sufficiently clean for our purposes. The concept was good, but the method of attempting to do this proved to be totally insufficient.

In other words, what they were doing was attempting to build into the goggles a pair of small tubes which would then be positioned into the mask cavity. Then when you put the regulator on pressure, you obtain a venting into the goggles.

The problem with the technique they were trying to use is that the tubes did not go into the mask cavity, but quite frequently would lie into the sealing area, and consequently never functioned.

The concept proved good, but the approach was not good. The solution to the problem was to use that concept of venting, but - instead of attempting to put tubes into the goggles - to build a valve system into the nose cup of the mask, which you see here on a Puritan quick-don type mask, a valve which would allow oxygen to flow from the mask into the goggles.

Now, so as not to compromise the performance of the mask during decompression, the valve normally would remain closed as you would see it here. As you would put the goggles on, the goggles would force the valve down and then would open the valve, as you see here. The competitors all took the identical same approach by using vent valves of one type or another.

The Scott Sierra mask - they have gone with the same concept, though the vent valve may appear to be somewhat different. In this case, the valve would be normally closed, and if you needed it after donning the mask and goggles, then you would pull the lever down, opening the valve and venting the goggles.

We found this system to be reliable, though there were some problems in the early stages of the development. One involved the amount of oxygen that was required to vent the goggles, and it looked as though this would require an additional cylinder of oxygen being incorporated into the aircraft crew system.

This is not a desirable feature due to the economic factors involved. By continuing the work with this system and by fine-tuning it, eventually, the manufacturers and CAMI were able to reduce the flow to the goggles through controlling the valve size and by controlling the pressure from the regulator, obtaining a system that did work and was compatible with the existing aircraft oxygen system.

Now let us go one step further taking the case of American Airlines B727. This was a case of a small bomb being placed upon the aircraft. It did not particularly damage the aircraft, but it did set it afire.

Smoke became very intense in the passenger cabin. The flight deck crew manually deployed the oxygen masks to the passengers who donned the masks, and their comments after the accident was over indicated that this action on the part of the crew members had saved their lives.

About two months later, we have a similar situation on Hughes Air West where the flight deck crew again manually deployed the oxygen masks, and the passengers indicated that this action had saved their lives.

Following these two incidents, both Boeing and Douglas issued bulletins to their customers pointing out that this procedure was of no benefit whatsoever to the passengers. Psychology was all that had been in effect. The type of mask we're talking about for the passengers, of course, is the simple, small, yellow plastic mask -- and I say simple in quotations because it is not that simple -- that we have all seen demonstrated.

Now, why would Boeing and Douglas issue bulletins stating that this mask did not work in the smoke and fume environment? Let's look very briefly at the function of the masks and its design.

First, the oxygen is accumulated in a reservoir bag. Now, this is not a rebreathing bag as a good many people think, but is merely a reservoir or collector bag for the accumulation of oxygen.

The mask itself is here. When the individual starts his inhalation, the valve opens here, and during the first part of his inhalation, he draws a high level of oxygen out of the reservoir which goes deep into his lungs where the gas exchange will mostly take place.

Once that reservoir collapses, we have a spring-loaded dilute valve which then opens and you pull in ambient or cabin air, and whatever else may be in that ambient or cabin air. Then when he exhales, it is vented out at this point.

The system was designed for decompressions. It is very efficient under those conditions on a very low flow of oxygen.

The problem that both Boeing and Douglas had is that unless you have a decompression, there is no flow activated to the mask. So that when the passengers put the masks on, they were simply breathing through the ambient dilute valve.

Now, if you have a decompression, the very low flow of oxygen which is delivered to the mask expands and provides for your ventilation rate. We are looking at this device at the present time to see what might be done with it to provide protection to the passengers with the existing systems.

The approach that has been most practical today is simply not to dump overboard the previous breath, but hold it in another reservoir which in turn is coupled back to the dilute valve so that we recycle part of the breath after we empty the reservoir.

The procedure is very simple. We may not get 100 percent protection with it, but at the present time, it looks as though a good deal of protection can be provided at very little added expense.

Thank you.

DR. DILLE: Thank you Don. At least half a dozen of our scientists have been involved in rather extensive tests of the acute effects of ozone on human and respiratory function performance. And giving a summary of many of these studies is Dr. Lategola of our physiology laboratory, a presentation entitled, "Effects of Ozone on Cockpit and Cabin Crew."

DR. LATEGOLA: Thank you, Dr. Dille. Ladies and gentlemen.

The majority of airline passenger and crew complaints attributed to ozone exposure consist primarily of respiratory irritation with cough and sub-sternal discomfort. Other common symptoms are headache and fatigue. Symptoms have been primarily associated with transpolar flights during late winter to early spring in the vicinity of major atmospheric low-pressure centers.

In April, 1977, the Civil Aeromedical Institute was requested to provide research in support of a proposed rule limiting airline cabin ozone levels.

The Aviation Physiology Lab, consisting of units headed by Drs. Higgins, McKenzie and myself, all under Dr. Melton's leadership, immediately began research preparations, and the first experiments were run in February, 1978. Four consecutive studies were completed by November, 1979.

Symptomatic effects of inspired ozone are intensified by the increased breathing of physical activity. Because flight attendants are usually more physically active during flight than other crew members or passengers, our first two studies were focused on the flight attendants. The third and fourth studies were focused on the sedentary cockpit crew members and passengers. A comprehensive battery of flight-related physiological functions were assessed in an attempt to define the threshold concentrations for adverse ozone effects under simulated flight conditions. All experiments were run at a pressure equivalent of 6,000 feet in an altitude chamber, in which relative humidity was kept at 10-12 percent, and temperature at 68-74° Fahrenheit.

The subjects in the first two studies were paid, 20-30 year old men and women, with height and weight characteristics of flight attendants. After medical examination and training for the experimental procedure, each subject was exposed to an ozone-in-air mixture in one experiment, and to air-only in another experiment. The two experiments were separated by one week.

The experimental schedule for the first study is shown in Slide 1. The subjects were run in pairs on a staggered time schedule. The first pre-altitude procedure was a respiratory questionnaire. For this, the subject first performed one maximum inspiration and expiration, and then rated the presence and degree of 5 symptom categories. Next, three maximum forced-vital-capacity efforts by each subject were recorded on a spirometer. From these recordings, six separate measurements of mechanical pulmonary function were obtained.

Then, after a standard breakfast, electrode placement and urine voiding, each subject was exposed to 0.2 ppm ozone-in-air for 4 hours at 6,000 feet in the altitude chamber. At altitude, each subject underwent a handsteadiness test, photopic vision testing, dark adaptation and scotopic vision testing, and a Wechsler short-term memory test. Interspersed with these tests were

four treadmill tests of 10 minutes each. The treadmill speed was 2.0 miles per hour for the females, and 3.0 miles per hour for the males. The treadmill incline was set at zero for the first 3 tests, and at a 5 percent positive incline for the fourth test. These treadmill loads were based on Astrand's study of flight attendant workloads, and were chosen to produce a heart rate of about 100 beats per minute in the first 3 treadmill tests, and 100 to 140 beats per minute in the fourth treadmill test. Heart rate and respiration were measured during each treadmill test.

Immediately after exiting the altitude chamber, 3 additional forced-vital-capacity efforts by each subject were recorded. The measurements from these recordings were divided by the corresponding pre-altitude measurements in order to calculate the change associated with exposure to ozone plus altitude. These calculated changes were compared to the same measurements in the no-ozone experiments as a measure of the effects of the ozone.

Immediately after the forced-vital-capacity recordings, the subject's respiratory symptoms were reassessed. The symptoms were assessed for immediate post-altitude effects, and for recollected symptoms right after the last treadmill test at altitude. The pre- and post-altitude symptoms were scored by algebraic difference, and compared to the scores of the no-ozone control experiments. Blood and urine samples were obtained for subsequent analysis.

The second slide presents a list of the tests run in the areas of vision, blood and urine in the first study. One can readily see that the search for threshold ozone effects was quite comprehensive

In all of the functions evaluated in the first study, no statistically significant adverse effects resulted from the 4-hour altitude exposure to 0.2 parts per million ozone.

As shown in Slide 3, the experimental schedule and tests in the second study were identical with the first study except that: each subject was exposed to 0.3 parts per million ozone for a duration of 3 hours, and a total of three treadmill tests were run at altitude. The first two treadmill tests were identical with the first three of study I, and the last treadmill test was identical in both studies. All other measurements and scoring were identical with those of the first study.

Summarized results of the second study are shown in Slide 4. Please focus your attention on the second vertical column. No statistically significant adverse ozone effects occurred in the heart rate, Wechsler, vision, blood, and urine tests. As indicated by starred items, statistically significant adverse effects for both males and females occurred in the areas of symptoms and spirometry functions.

Regarding subjective symptoms, the differences between the ozone and no-ozone mean scores within each sex group were statistically significant for the immediate post-altitude period as well as during the last treadmill test at altitude. The highest mean score occurred in the male group during the last treadmill test at altitude. This score indicates a "slight" to "moderate" degree of discomfort. The remaining three mean scores for both sexes also lay between "slight" and "moderate" discomfort.

No experiment had to be terminated because of intolerable symptomatic stress on the part of any subject.

Throat irritation was the most prevalent symptom, reflected usually by involuntary coughing during forced vital capacity efforts. Substernal discomfort, and dry or burning eyes were second and third in prevalence. One male suffered breathing discomfort for three subsequent days. Two males and two females reported considerable lassitude for two subsequent days. Symptoms in all other subjects disappeared in four hours or less. Symptoms of these degrees and durations after a single ozone exposure are considered to be completely reversible.

During the last treadmill test, which was lighter for the females than for the males, the mean symptom score for the females was greater than that of the males, even though the females' pulmonary ventilation was about 35 percent less than that of the males. This appears to indicate the presence of a greater symptomatic sensitivity to ozone in the females as compared to the males.

The mean heart rates achieved by both the males and females during the 30 total minutes of treadmill work approximated Astrand's reported mean level of 108 beats per minute for a four-hour work shift in flight attendants. Because increased ventilation of physical activity increases ozone symptoms, an increased treadmill time for the females would have increased the observed ozone symptoms. Since no significant symptoms occurred in the first study,

0.2 parts per million ozone, for 4 hours with 4 treadmill tests, then the ozone threshold for symptoms in flight attendants is probably greater than 0.2 parts per million, but less than 0.3 parts per million.

Regarding pulmonary function, all 6 of the spirometry parameters within each sex group were decreased by ozone with statistical significance. Within each sex group, the last three parameters, manifested greater decreases than the first three. Those last three parameters are known to sensitively reflect resistance changes in the smaller airways of the lung. The mean decreases in these three parameters ranged from 6.5 to 15.6 percent.

Because the more prevalent symptoms reflected upper tracheobronchial discomfort, the significant decreases in the first 3 parameters were not surprising. However, because no subjects experienced symptomatic discomfort in the peripheral portions of the lung, the larger significant decreases in the last three spirometry parameters were somewhat unexpected. In more severe ozone exposures, one of the potentially serious effects is pulmonary edema. Therefore, in order to minimize possible adverse effects of substantial ozone exposure, the removal of the person from the ozone exposure at the first definite symptoms of throat and substernal discomfort would appear to be a prudent action.

Because increased ventilation increases ozone symptoms, increasing the treadmill time to approximate actual duty durations of flight attendants would have intensified the adverse spirometric effects of the ozone. Therefore, the ozone threshold for adverse mechanical pulmonary effects in flight attendants would have intensified the adverse spirometric effects of the ozone. Therefore, the ozone threshold for adverse mechanical pulmonary effects in flight attendants most probably lies between 0.2 and 0.3 parts per million.

Let us now shift our attention to the more sedentary cockpit crew members. The subjects in this study were male smokers and nonsmokers, 40 to 59 years of age.

The experimental procedure resembles that of the second study except that: all treadmill tests were omitted.

The next slide summarizes the findings in this study. No statistically significant adverse ozone effects occurred in the heart rate and short-term memory tests.



Regarding symptoms, all smokers and nonsmokers combined manifested small but statistically significant symptoms with ozone exposure. The largest mean symptom score occurred in the 40-49 year-old nonsmoker group, and this score was in the "slight" to "moderate" discomfort range. The observed symptoms generally disappeared within 4 hours, and were considered to be completely reversible.

Eye discomfort was the most prevalent symptom, followed by headache, nasal irritation, and throat irritation. The substantial eye irritation was most probably the main reason for the small but statistically significant decreases which occurred in four of the vision tests. The increase in eye symptoms probably resulted from the fact that eye testing was done towards the end of the 3-hour ozone exposure in this study as compared to the second study, in which it was done towards the beginning of the ozone exposure. The increased nasal irritation may have resulted from the more naturally-occurring nasal breathing of sedentary rest, as opposed to the increased oral breathing during the treadmill tests of the second study. Since nasal breathing is known to scrub ozone, then, in the case of unavoidable ozone exposure, nasal breathing could partially protect the deeper portions of the lung.

All smokers and nonsmokers combined manifested small but statistically significant decreases in 3 spirometry functions due to ozone. Most of the decreases occurred in the nonsmoker group. The lesser effect of the ozone on the spirometry functions of the smokers was probably due to the prior desensitization of the smokers' lungs by accumulated smoking damage. Other studies have shown that greater ozone exposures do adversely affect the smoker's lung more than that of the nonsmoker.

Because adverse effects observed in this study were statistically significant, but small in degree, the ozone threshold for adverse effects in sedentary cockpit crew members is probably right at 0.3 parts per million. That same threshold should also be valid for sedentary passengers.

Subsequent to evaluation of all ozone studies, an FAR (Federal Air Regulation) was issued on February 20, 1980. The time weighted average of 0.1 parts per million and peak level of 0.3 parts per million ozone, corrected to sea level, were adopted for the in-flight commercial airline cabin. The time weighted average of 0.1 parts per million refers to flights of more than four hours duration.

Thank you.

DR. DILLE: Thank you, Mike. The next presentation has the very broad title of "Influence of Alcohol, Drugs and Pollutants on Brain, Behavior and Performance" by Alvin M. Revzin, who right now is our Neuropharmacology Research Unit.

DR. REVZIN: Thank you, Bob.

Aviation personnel may be exposed to a wide variety of toxic chemicals, drugs and environmental pollutants. I shall lump all of these things under the generic name of toxicants. My research work involves measuring the effects of some classes of these toxicants on brain functions. The objective of this research is to determine the exposure levels and circumstances at which these toxicants can affect job performance. Achieving this objective has required development of special methods which, though sensitive and predictive, are technically very difficult and time-consuming.

The work I will briefly describe today was based on evaluating the toxicant-induced changes in the response properties of single nerve cells in those subcortical visual areas concerned with peripheral vision in experimental animals. This approach has two virtues: It has proven to be very sensitive. If a toxicant produces changes in the response properties of a class of neurones, it is unambiguous evidence that visual functions have been disturbed. Such disturbances can be missed in human visual studies/examinations since most of these do not test peripheral visual functions and incompletely test central functions.

I have studied many toxicants with these methods, but will concentrate on three: organophosphate pesticides, ethyl alcohol and microwave radiation.

Ethanol: The primary data is very simple. Ethanol induces a sharp decrease in the sensitivity and specificity of posterior thalamic neurones concerned with peripheral vision. The threshold dose is about 5 mg percent (0.005 gm/100 gm). This corresponds to about a third of a shot of whiskey for most of us. Neurones in other visual protection systems were 4-10 times less sensitive to ethanol than were other thalamic sensory and motor nerve cells.

These results were obtained in anesthetized animals but quantitatively similar data is now being obtained in studies of the effects of ethanol on peripheral vision in human volunteers, confirming the power and sensitivity of the approach.

The visual mechanisms I was using are concerned mainly with regulation of visual attention. Normally we "look at" -- our attention is directed at -- things projected onto the fovea. The central  $1^{\circ}$ - $3^{\circ}$  of the retina. If significant events ( an airplane coming down the taxiway as we are preparing to take off, or a truck coming through a red light) occur in peripheral (extra foveal) vision, the system I was recording from tells this to the brain and, if we so decide, the system also generates the appropriate eye movements required to foveate, examine or "pay attention to" the new event. Alcohol inhibits this mechanism, so that, as blood alcohol levels increase, we become progressively less responsive to events in peripheral visual areas -- the classic "tunnel vision" of the drunk. Clearly, in the complex visual environments of aviation, such inhibition of vision is undesirable and dangerous. That such inhibitions occur at extremely low blood alcohol levels is also disturbing -- it certainly changed my own social drinking patterns! It suggests that any alcohol in the blood could be a factor in accidents occurring in heavy traffic where ability to respond to things happening all about us is critical. Under lower sensory loadings, there is probably no problem, since we have other mechanisms to take care of the peripheral reflex, including simply monitoring by turning our heads. One more point. These are reflex functions -- we will not be aware of dysfunctions. Indeed, the reduction in awareness of the entire visual world may contribute to our sense of well-being under ethyl alcohol since there seem to be fewer things out there to disturb us.

We also devoted a lot of time to the investigation of toxic effects of organophosphate pesticides and related chemicals used in agricultural aviation. These include not only the organophosphate pesticides, but the carbamate based pesticides and therapeutic drugs used to cure the effects of poisoning, notably Atropine and Pralidoxine.

But the use of organophosphates is dangerous. It's quite well known. In high doses one sees a variety of symptoms beginning with muscle twitches

and parasympathetic symptoms, symptoms of parasympathetic discharge, and ending in gross seizures and death with high levels.

There is also some anecdotal evidence suggesting, and some experimental data, suggesting that prolonged exposure to organophosphates results in visual dysfunctions of various kinds and sleep dysfunctions. Conceivably interferences in pulmonary metabolism could be one of the dysfunctions contributing to the development of Alzheimer's Disease, senile dementia.

In my father's area of Michigan, where there were a lot of fruit farmers, people used to say that you had to watch out in driving because people don't drive very well during spray season. Clearly, high doses are toxic. What about low doses? Well, we tested it in a system similar to the one just described. As background and as noted, we studied single units, but these are not uniformly responsive to stimuli. The units were variously sensitive to the size and motion of the stimulus, some responding to targets a degree of arc or less, others responding only when the target size exceeded 40 degrees of arc, a very large target. They differed enormously in the sensitivity to velocity, some responding to velocities so slow that I have difficulty seeing it, others at very high velocities.

The main class, however, was directional selectivity units. That is, the cell would respond maximally when the target moved in one direction and would not respond at all or, indeed, would be inhibited when a target would move in some other direction. There were other complexities as well, but to cut a long story short, the organophosphates pesticides abolished the directional selectivity of directionally selected cells and did not do anything else. This occurred at doses substantially lower than the threshold doses required to see any peripheral effects.

The effects lasted a long time, a matter of hours, which is the limit of useful time to follow any one unit with this measure. Higher doses, as befits a convulsive agent, just generally increased the excitability of the whole system. So, organophosphates had a limited and very highly specific effect on the system which occurred at very low doses. Carbamate pesticides did the same thing, again, at very low doses.

Pralidoxines, which is used in the therapy of organophosphates pesticide poisoning, did the same thing. Atropine and other materials, which are used

predominantly to antagonize the central effects of organophosphates and carbamate pesticides, did the same thing. Any perturbation of cholinergic function blocked the directionally selected response, with some evidence that other things were happening as well. The abolition of directional selectivity means that erroneous information is being relayed from the eye to the higher brain centers. As with alcohol, normally this is probably not terribly significant since other cues about the visual universe are available.

In an emergency situation with rapid signal input rate, which has to be evaluated, the presence of erroneous information simply increases the probability that the pilot will move his controls in the wrong direction.

And at the postmortem, his widow will be told that since there was little decrease in blood cholinesterase, the accident was undoubtedly due to pilot error. This can be exacerbated in a sense because there is also evidence that colds, other viral infections, arsenic pesticides and other things which can affect the blood-brain 'barrier,' can, on a moment-to-moment basis, greatly increase the sensitivity of the organism to the presence of organophosphate and carbamate pesticides.

What all of this taken together means is that there is no real therapy for many or most central effects of organophosphates. Indeed, there is good evidence which I got in another system, that that treatment of organophosphate pesticide poisoning with atropine may exacerbate many of these effects of the pesticides.

Clearly, the only solution to the poisoning situation is to avoid exposure, to use whatever protective cockpit devices are available, to wear protective clothing at all times and to make sure that your spray controls are adequate. This is especially critical not only to the pilot, but for ground personnel and other people who may inadvertently be exposed to the sprays and get in their automobile and drive for a few miles cross-country thereafter.

I should also note that these studies emphasize acute or single exposure to organophosphates, ethanol and other factors. A good deal of evidence suggests that the real problem with many of these may lie with the real world situation where we are exposed to repeated and small doses of these things over a period of time where a variety of unexpected summations occur.

I would go on in a lengthy exposition about microwaves, but in light of the grimness of what I have been talking about so far, I'll content myself with saying that contrary to my expectations when I initially went into the research, there seems to be, at least with the acute situation, no toxic problem caused by exposure to microwaves at levels under the de facto standard of 10 milliwatts per square centimeter.

Thank you.

DR. DILLE: Thanks, Al. William E. Collins, Chief, Aviation Psychology Laboratory, will now summarize psychological research on flight-related performance and workload problems.

DR. COLLINS: The Civil Aeromedical Institute's (CAMI) Aviation Psychology Laboratory has been involved in research relevant to the human factors aspects of aviation safety for over two decades. The laboratory is dedicated to the conduct of research in experimental and physiological psychology relating to current and anticipated biomedical and behavioral problems. That research has included, but has not been limited to: the psychological and psychophysiological aspects of work proficiency; the relationship of various sensory processes (such as vision, audition, spatial orientation, and others) to performance; person-machine relationships; problems in air-ground communication; the effects of various types of stress on human performance; personnel systems; selection, training, and job performance, particularly of air traffic controllers; and the measurement of aptitudes and abilities as these relate to aircrew and ground personnel. Our work in the area of personnel systems has produced a number of significant accomplishments related to agency personnel and programs. Those contributions will be covered in a subsequent presentation.

In this discussion we will briefly note some of the kinds of research findings that we have generated in the laboratory and other types of studies of performance related to human factors problems of safety in flight. We have arbitrarily divided our studies into four main sections for ease of discussion.

Sensory Research in Flight Safety. Fundamental to any human factors base for performance assessment are the human sensory systems, particularly those that provide visual and auditory information. These systems are also

significant in that their functions (along with cognitive processes) are subject to various demands and stresses in aviation environments and thereby influence both safety and health.

In the area of audition, our laboratory has provided the agency, aircraft manufacturers, and the flying public with noise-level data for single engine and twin engine aircraft, for helicopters, and for crop dusting aircraft activities. Based on those data, we have provided the agency, CAMI's Aeromedical Education Branch, aviation medical examiners around the country, and the flying public in general, with data-based recommendations for protecting the hearing of pilots. We have gone about evaluating the various types of ear protectors and have developed a 3-number rating system for ear plugs that is currently being used by the Occupational Safety and Health Administration (OSHA) in that agency's basic training of inspectors. We also completed a successful assessment in CAMI's evacuation simulator of using speech signals to direct passengers to emergency exits when vision is obscured in the cabin.

We have used animals in those studies where they were required to assess the effects on visual performance of pesticides used by crop dusters. We were able to demonstrate significant decrements in performance before the usual symptoms of poisoning appeared. That cautionary information is being communicated to pilots engaged in aerial application through CAMI's Aeromedical Education Branch. Similarly assessed was the biomedical and behavioral interaction of marijuana and altitude on visual performance. The prepotentiating effects of altitude on marijuana-related performance decrements was demonstrated in animals and has served as the basis for several university studies using human subjects.

Color in various types of displays -- both for the air traffic controller and the pilot -- is a current human factors engineering effort. One biomedical side of the question involves color vision, and we have been active at CAMI in assessing the validity -- or lack of validity -- of several of the color vision tests -- and types of tests -- used in the medical examinations required of pilots and controllers. Color is also a feature of some visual approach slope indicator (VASI) systems and we have explored, in simulators, the effects on landing performance of different types of VASI's. In other simulator experiments we have varied the visual cues (e.g., the length and

width of runways), and determined the perceptual effects of those variations in efforts to quantify the various visual illusions that occur, particularly in "black hole" landing situations. Approach angles produced in a simulated "black hole" situation tend to be lower than desirable and are extremely variable. "Black hole" approaches were also significantly lower with long or narrow runways than with short or wide runways. Those studies support visual effects as practical contributors to illusions, and "size" cues in the runway image as important determinants of those illusions.

Performance and motion related to accident findings. The Aviation Psychology Laboratory has had a long-standing interest in the problem of spatial disorientation. The problem area is a significant one since statistics over the past several years indicate that spatial disorientation is consistently the third leading cause of general aviation fatalities. Our research in this area has involved field surveys of Aviation Medical Examiners (regarding medical tests related to detecting impairment in orientation systems) and flight schools (regarding training in spatial orientation). Based in part on those surveys, we have made educational recommendations regarding flight training and recommended against the introduction of new or more specific physical examination requirements. Based on our laboratory studies, we devised a methodology for familiarizing pilots with disorientation experiences on the CAMI Disorientation Device. A private manufacturing company in the aviation field enlisted our support in producing portable devices -- Vertigons -- patterned after CAMI's for general educational purposes. CAMI's Aeromedical Education Branch has two of these devices and sends them to aviation safety meetings, air shows, and similar events all around the country. Tens of thousands of general aviation pilots have "flown" this educational device and have been given the safety briefing that goes with it. The Air Force has recently purchased about 30 newer versions of this familiarization tool, all based on the original CAMI methods.

Analysis of general aviation accident statistics and accident reports (through the courtesy of the National Transportation Safety Board) have also been conducted. With regard to spatial disorientation, it is clear that pilots need an appreciation of the problem (our Vertigons help to provide that opportunity) and that a variety of educational techniques -- which we have



specifically outlined as recommendations -- are necessary to give pilots "a built-in association between adverse weather, disorientation, and fatal accidents."

The human factors aspects of "propeller-to-person" accidents have also been subjected to analyses through accident reports. Our data indicate that the person most at risk for being struck by a rotating propeller is a passenger who is either deplaning or assisting the pilot. Our analysis of factors associated with this type of accident led us to make several types of recommendations -- in a report currently being reviewed for publication in Washington Headquarters -- ranging from education to procedures to hardware.

Our approaches to these various human factors problems have involved field surveys, analysis of accident records, and also laboratory studies. With respect to the latter, and based on our research experience regarding spatial disorientation and other influences of motion on the human operator, we have conducted several studies to assess specific effects of alcohol and a few other drugs on performance during yaw-axis movement. Our initial studies on joystick tracking behavior of a localizer/glide slope instrument indicated that doses of alcohol which were too low to influence this type of performance in a stationary environment were effective in producing performance decrements during the additional stress imposed by motion. Similar results are obtained with ordinary doses of depressant drugs, including Dramamine, an over-the-counter preparation to prevent motion sickness. The importance of these findings in assessing potentially adverse influences of drugs on performance in any transportation system is clear -- the possibility of undesirable side effects specific to motion must be considered.

We have also been examining performance during the so-called hangover stage following alcohol intoxication. These laboratory studies have been geared particularly to the FAA's "8-hour rule" of abstinence from alcohol prior to flying. So far, our tests indicate no deleterious hangover effects on tracking performance during motion, on the MTPB, or on speech perception against a background of aircraft noise. Our studies are, however, in no way complete since we have worked with relatively moderate peak blood alcohol levels (averaging 90-100 mg percent) and have not incorporated the additional interactive stressors of altitude, noise, and vibration.

Our current research efforts involve alcohol/altitude/noise interactions and their influence on performance at different workload levels.

Complex performance and workload. Our laboratory research in human factors problems related to both individual and team performance has made use of CAMI's Multiple Task Performance Battery (MTPB). The MTPB was originally developed for the Air Force by the Lockheed Company to provide an array of six synthetic tasks specifically designed to assess skills relevant to piloting an aircraft under varied conditions of workload. The six tasks include: detection of changes in red and green warning lights; monitoring changes of needle deflection in four meters; mental arithmetic; a two-dimensional compensatory tracking task with a joystick control; individual and group problem solving; and pattern identification. CAMI work on the MTPB has led to probably the first data-based, quantitative documentation of a separate human ability to "time-share" -- a concept in frequent use in human factors research. We have also used the MTPB to establish rates of adaptation and significant factors in performance modifications during laboratory simulations of time-zone changes. And, in the process of being published as OAM (Office of Aviation Medicine) reports are two recent studies -- one of which showed no deleterious effects on performance of a 24-hour crash diet and another which demonstrated some specific declines in performance during a few hours of withdrawal from cigarette smoking. Although additional research is needed, the latter finding, has considerable current implications for proposed rules regarding any ban on smoking in the cockpit of aircraft.

We have also been examining some aspects of noise on performance. We have recently assessed effects of 24 hours of sleep deprivation on 2-3 hours of MTPB performance with aircraft noise present, and ear protection used in some tests and not used in other tests. Of interest is the finding that, while sleep loss produces clear performance deficits, less deficit is present without ear plug protection against the noise stressor than with ear plug protection.

Our MTPB complex is currently in use in support of research projects conducted by CAMI's physiologists and in the assessment of aeromedical implications of alcohol usage under varying workload demands.

A final area of our laboratory research which involves workload is oriented more toward the human factors aspect of air traffic control work than it is toward piloting aircraft. However, our approach has implications for certain types of piloting behavior and represents an attempt to be a step ahead of current workload issues by assessing the human demands imposed by the generics of a proposed future hardware system. Specifically, we have been concerned with questions related to vigilance and monitoring ability using computer-generated radar displays. Our displays incorporate alphanumerics and our research scenarios require less control of the simulated traffic than they do the detection of specific "significant" changes which occur relatively infrequently. The tasks might thus be considered to be low on a workload scale and the primary demand is that of monitoring computerized traffic changes.

Our most recent studies in this area have some direct personnel implications. In one study we established the similarity of performance of both men and women with the various measures of performance on simulated radar tasks. Our most recently completed task -- our report of which is currently being reviewed in Washington Headquarters for publication purposes -- involved age differences in radar monitoring performance. Our results indicated significant performance deficits across a 2-hour monitoring session which were greater for our 60-year old subjects than they were for 40-year olds, which in turn were greater than those obtained for 20-year olds. The application of these findings to current considerations regarding changes in the agency's "age 60" rule is fairly obvious.

During the current budget-imposed hiatus in training at the Academy, we are working with instructors in the Academy's air traffic training program in evaluating vigilance problems under low task loads in highly automated radar systems. We are also looking further into the question of age and performance decrement -- we are examining the possible effects that the wearing of bifocals might have on these decrements. And, finally, we are pursuing studies to determine personality and physiological predictors of performance decrement on monitoring tasks.

Thank you very much.

DR. DILLE: The fourth Laboratory chief we'll hear from is Carleton E. Melton, Chief of the Aviation Physiology Laboratory. Carl's had considerable involvement in the ozone and other studies and also a lot of experience in Studying stress in air traffic specialists, student pilots and the like.

I believe this is the first presentation on fatigue and stress in flight inspection crews.

DR. MELTON: Thank you, Dr. Dille. Before I get to the flight inspection experiment, I'd like to go back and talk about some of our earlier experiments as far as overview and share with you some of the reasons how we got into that work and what we hoped to accomplish by it.

I had a personal experience the other day that I think is illustratiye of the main reason I think we're here at this conference. On my desk at home I have a squeeze bottle of glue and a squeeze bottle of eye drops. Now, these are both made of white opaque plastic, but of different shapes, and I had a recycled stamp that didn't have any stickum on it, and I attempted to put some glue on it, but I got the eye drops by mistake and squirted the eye drops all over the stamp.

It didn't amount to very much. I just wiped it off, swore a little bit, but I got to thinking, Would it have been a bigger mistake if it had been made the other way around and I put the glue in my eye? And I decided it probably wasn't a bigger mistake, but the consequences were much greater.

And I think in aviation we tend to judge the size of the mistake by the size of the consequences. It's not uncommon for a pilot to line up on the runway, and particularly if its a left and right runway situation, even to land on the wrong runway. It commonly doesn't make any difference; a little embarrassment maybe. The controller might chip at you a little bit. But it did in Mexico City. And yet the man in Mexico City didn't make a much bigger mistake than, say, the general aviation pilot at Will Rogers would, but the consequences were much, much greater. And it appears to me that there is a base rate of error that we're never going to pass in the system, that it's just the way the computer is built and there isn't going to be a model change in the future that we know about.

So I don't think we're ever going to get this error rate out of the system and we'll probably always have accidents that are due to some fundamental errors of confusion.

However, there are some things we can do about it to minimize accident rates and improve safety. One is we can make the system more tolerant of error. We can make a more forgiving system, recognize that this error rate is greater than zero.

The other thing we could do is make sure through training, proficiency, recurrent training, education, selection, certification, all those things, that we have a system that keeps the error rate at that absolute minimum level.

And what we've been doing in the physiology laboratory for the last 20 years is looking at factors in the aviation system that keep the error rate higher than it needs to be.

I guess you could say we began at the beginning in this area of work because we started with student pilots who had no previous flight experience. The first group we put through a perfectly conventional syllabus, unstructured. We provided no input to syllabus.

We turned the fixed base operator loose on them. We went along and made measurements on them (Dr. Crane was one of those; he remembers it very well) and followed them through the syllabus.

Now, characteristically, when these students began in this syllabus, they were joyful, realization of a dream to fly, wide open for learning, relaxed. In this highly desirable state under the tutelage of classical instruction technique, you might say, they progressed over a period of flights to a level of terror that caused the physician who was in charge of the laboratory, where urine analyses were being conducted, to phone and ask if one of our students had a tumor because his output of adrenaline-like substances was so great that it appeared to be pathological. This student was actually hospitalized for studies as a result of this.

This taught us that the instructor was probably the most powerful stressor in the system, and paradoxically, the greatest impediment to learning. We took another group of subjects, took a rather frontal attack on the problem, and gave the students a tranquilizer, carefully supervised on dual flights, of course.

Now, this didn't have very much effect. We probably gave the tranquilizer to the wrong person. We probably should have given it to the instructor, and

I think we would have gotten better results.

We then pulled out all the stops, hired an instructor who was the picture-book type: experienced, mature, modern in his approach. We used the best syllabus that we could come up with, a highly idealized syllabus. We incorporated a ground trainer into the syllabus for ten hours of instruction for half the students. The other half got all their training in a Cherokee. And we found indeed that the stress levels were markedly reduced. And we found additionally that those who got their training on the ground, part of their training in the ground trainer, did just as well as those who got all their training in the airplane and at a much lower physiologic and economic cost.

So with this background, we found and strongly believe that this business of quality instruction is more than a nicety. It's a safety factor. These pilots are safer pilots.

In the old group, some of them are still flying, and they're still flying with the fears that were taught to them when they were students.

One of those students participated as a private pilot in a later study, and on landing at Love Field, when that airport was a principal terminal for that area, had a heart rate of 180 beats a minute.

Now, we wouldn't allow a person on a treadmill to obtain that level of heart rate because it wouldn't be safe. And this person was sitting quietly in a cockpit of a Cessna 150, and that's been shown to be light work.

So this is a very ponderable stress. Those students suffered a level of stress that's comparable to Gemini astronauts on blast-off. So it's something to recognize and be dealt with in a modern way and in a good training syllabus.

We, in our latest series of experiments, were called upon to evaluate fatigue in flight inspection pilots because of, I guess you would say, the increase in work density resulting from the shift from propeller driven aircraft to executive jets.

And so we went to each of the Flight Inspection Field Offices in the Continental United States, seven of them, and studied the three-man crews at each of these Flight Inspection Field Offices.

These three-man crews, for those of you who don't know, consist of aircraft commander, copilot and electronics technician, who turn the measurement gear to check the calibrations and specifications of the navigational aids.

Characteristically, these crews work five days in the office and then they're on the road. They're in the air for five days doing flight inspection work away from the office. So we studied each crew for a week in the office and then a week doing flight inspection work.

The principal instrument that we used for measurement here was the fatigue checklist which was developed at the U.S. Air Force School of Aerospace Medicine at Brooks Air Force Base, and validated there.

We also made physiological measurements on them in flight, recorded the electrocardiogram continuously and collected urine specimens from them for biochemical analysis.

The crews commonly expressed the opinion that office work was more fatiguing than flight work was. This was one comparison we were very interested in since flight work has been shown by Lattle and Joy and others, including ourselves, to be light work; that office work and flying are of similar character as far as metabolic expenditure is concerned. So if we could take that first slide. This compares the prework values by crew positions that you see along the bottom there. The fatigue checklist score should tell you that the lower the score, the greater the fatigue; the lower the number, the greater the fatigue.

And this simply shows that when they report for work, regardless of whether it is flight or office, they are equally rested, except for technicians, who apparently report for flight work somewhat more fatigued than they do when they report for office work.

And after work, the same sort of thing, again, the lower the bar, the greater the fatigue. It shows that in all positions the flight work is more fatiguing than office work.

Now, this we interpreted as being a confusion of work preference with objective work intensity. The fatigue checklist forces the individuals to choose descriptors that indicate true fatigue rather than "you make me tired" kind of fatigue, which they probably experienced in the office - negative feelings that are summed up as a statement of fatigue.

And the differences there are significant at the one percent level between flight work and office work. This is how the fatigue checklist differs. The difference in prework and postwork values shows the same thing. The difference is greater for flight work than it is for office work, but both of them would be described as light physical work. So there's an added component to fatigue in flight work that doesn't appear in office work. And this is again much the same at these different Flight Inspection Field Offices: Seattle, Los Angeles, Minneapolis, Battle Creek, Atlanta, Oklahoma City and Atlantic City.

And it shows prework and postwork values in the office and preflight and postflight values at the different FIFOs. And again it shows that fatigue is greater after a flight. At each of the offices, it is a consistent finding.

And this is the difference in prework and postwork by facility. And again, it is a consistent finding, though at some the difference is greater than at others.

Day by day, fatigue levels are shown here. The dotted line shows fatigue levels in the office, prework at the top and postwork in solid circles lower down; and for office work, it shows that the lines are fairly flat.

This indicates that there is a complete reversal of fatigue during the rest period, but for flight work there's apparently an accumulation of fatigue over at least the first four days of flight indicating that there is not a reversal of fatigue during the rest period.

The end spurt phenomenon is very characteristic of people who have an imminent expectation of release from duty on the fifth day. These are heart rate values taken from the crews and it shows office and flight values at the separate FIFO's.

It shows heart rates are higher during flight, significantly so in most cases, than in the office. And this gives us some insight into the fact that sympathetic outflow arousal is a good deal higher in flight, even though it might not be reflected in metabolic measurements, than it is in the office.

And this is heart rate, office and flight, by crew position, and it shows that for aircraft commanders and copilots there is a significant difference between flight and office and not a significant difference for technicians,



though technicians show somewhat higher mean heart rate than do the cockpit crew members.

Well, the conclusions that we can draw from this are -- oh, and I should mention the urinary studies that the FIFO flight crews show somewhat less chronic stress than do other corporate groups that we've studied, other workers here at the Aeronautical Center, air traffic controllers and experimental subjects in the laboratory. But they do show a somewhat higher acute workload level than these other workers groups.

This report is still being evaluated in the office flight operations and I can't report to you what adjustments might or might not occur as a result of these studies.

We did show in one or two cases, particularly in the case of technicians, that by the Air Force criteria, severe fatigue was evident.

In some cases, moderate fatigue levels were evident in cockpit crews. Yet none of these people, either biochemically or by the fatigue checklist instrument as a group, were outside the range of normal.

Well, I see my time is up. Thank you.

DR. DILLE: In a given year, about 25 percent of our research effort is devoted to aircraft control specialists. And on this morning's agenda, we have only one, the forthcoming paper by Jim Boone, from our Chief, Selection and Testing Research Unit, on psychological research on air traffic control specialists. We hope that most of the other significant data we can offer will come out in the workshop in the tour portion for the air traffic control group tomorrow.

DR. BOONE: An important area of research at CAMI's Aviation Psychology Laboratory has been the methodical detailing of the attributes of air traffic control specialists (ATCS's). Of particular interest are those attributes that discriminate between successful and unsuccessful ATCSs. Research has centered on two areas: the screening of ATCSs, initially through use of a selection battery and during developmental pass/fail training phases, and the characteristics of the workforce once ATCSs become full performance level controllers.

The entire screening process for ATCS candidates is a sequential procedure consisting of the initial Office of Personnel Management selection test

battery, basic non-radar and radar training phases at the Federal Aviation Administration Academy in Oklahoma City, and approximately ten phases of training in their respective field facilities. All phases of training are pass/fail. This presentation covers each component of the three screening steps individually.

CAMI began research on selection by administering a series of tests to newly selected ATCSs and correlating the test results with Academy performance. Normally this is done in the Headquarters auditorium on the first day prior to any training. Regression analyses resulted in a five test battery that best predicted Academy success. The present OPM selection test battery consists of these five tests recommended by CAMI researchers. There are: arithmetic computation, spatial relations test, complex oral directions test, abstract reasoning test and ATC problems test.

Prior to the selection battery implementation, CAMI studies revealed that attrition at the Academy was approximately 30 percent while field attrition was about 20 percent. Later CAMI studies on classes after implementation of the selection battery revealed a significant drop in attrition at the Academy to 22 percent and in the field to 16 percent.

Presently CAMI is involved in research aimed at assessing several new tests that show promise for inclusion in the selection battery. If everything continues as planned, implementation of a new selection battery should occur in fiscal year 1982. This should further decrease training failures. Full evaluation by CAMI of the new battery will occur after its implementation.

Other significant CAMI research on attributes used for initial selection are summarized as follows:

Age effects. CAMI studies on age differences are viewed by many in the agency as representing the most significant improvement in the selection process. CAMI studies revealed that training attrition rates for trainees 31 years of age and older are two to three times as high as those 30 years of age and younger. These CAMI studies played a decisive role in Congressional legislation establishing an optional early retirement for ATCSs and the imposition of an upper age limit of 30 on recruitment of trainees.

Prior experience effects. The only ATCS related experience found to be a valid predictor of success was prior experience with IFR (instrument flight rules) traffic control, i.e., radar. Aviation experience, such as being a pilot, or VFR (visual flight rules) ATC experience, i.e., nonradar, did not predict ATC success. Based on this research, CAMI recommended that limited points be given for some prior experience, such as VFR ATC, and that points be eliminated in other areas such as prior pilot and communication experience.

Education effects. CAMI research has found no education variable that is consistently predictive of ATCS success. In some cases educational level appears to be inversely related to Academy success. These results have led CAMI to recommend the elimination of extra points on the basis of education.

Sex effects. CAMI studies on sex differences in performance at the Academy showed no significant difference between men and women. Significantly fewer women were found to have prior ATC experience. Field attrition showed women attriting at higher rates. However, the differential attrition was mainly due to personal reasons. This result led to a more precise definition of causes of attrition in women ATCSs.

Following initial selection, the second stage of screening occurs at the FAA Academy. The program consists of a nonradar phase with two program components: academics, where students learn in a classroom environment basic knowledge requirements; and laboratory performance, where the knowledge is applied. The program also consists of a newly established radar phase also containing academics, where again the student learns basic knowledge and laboratory performance, where the knowledge is applied. CAMI is responsible for the entire program evaluation of both these programs. This includes the development of measurement devices as well as monitoring the program's progress and quality.

The program evaluation model designed by CAMI for ATCS Academy research contains four components. These are: design evaluation, implementation evaluation, formative evaluation, and summative evaluation. Program design and implementation evaluation, as the terms imply, occur at the beginning of the program. Formative and summative evaluation are the more important phases and occur simultaneously, and serve to evaluate the process and course of the program and its products. Each of these evaluation components uses the

techniques of statistics, math modeling, and various reporting systems. The mainstay analytical tool is our VAX 11/780 Computer system. Our data files consist of 587 columns on approximately 8,000 ATCSs. On input-by-input basis, formative statistical reports are summarized for research purposes and for transmittal to decision-makers. Statistics include sample sizes, means, standard deviations, intercorrelations, pass/fail rates, reliabilities on tests and labs, tests for parallelism on different forms of the same measure, and item parameters, i.e., item difficulty, item discrimination, and the validity of parallel laboratory problems and new items for parallel tests. Further, statistics are cumulative up to and including the most recent input.

When, based on the formative summary data, there appears to be a problem in how the training program is running, CAMI has the responsibility to alert the appropriate administrative personnel and prepare a concise report identifying the problem areas. Isolating the exact area requires considerable mathematical modeling.

Statistics and reports are summarized from the summative data base on a periodic basis for research and as information for decision-making. Statistics include sample sizes, means, standard deviations, intercorrelations, validity coefficients, attrition rates, and mathematical modeling. Attrition data is stratified by minority status, sex, prior experience, type of entry, veteran's preference, educational level, reasons for attrition, option, and region.

If the summative data base demonstrates a problem in the program, CAMI indicates a need for a major program revision. The data are reviewed very carefully to isolate the source of the problem. As in the formative evaluation the decision-makers are alerted to the problem but, in addition, in the case of the summative data, Washington level policy-makers and Aeronautical Center officials are alerted. Major program revisions require careful planning and more detailed attention than revisions based on formative data.

An example of a particularly significant and current Academy procedure which resulted from identification in the implementation data base of a need for a major program revision is that of the relative weight of performance measurement components in the nonradar lab. Our identification and recommended revision led to a revamping of the assessment program at the Academy where laboratory scores were weighted far more than academic scores in forming the

student's composite score. Prior to this revision the enroute Academy attrition rates were about 4.5 percent and later summative data on this group yielded a field attrition rate of 24.4 percent. After the scoring revision, the attrition rate at the Academy rose to 16.2 percent, while CAMI summative data of this group showed a drop in field attrition to 17.6 percent, indicating that attrition after the change was occurring at the Academy rather than three years later in the field. Modifications made in the screening process based on the CAMI research formative and summative data base has led to present 30 percent attrition rate at the Academy and an 8 percent attrition rate in the field.

In summary, what are the bottom line products for CAMI research in screening? Based on the selection battery research, we noted a decline in Academy and field attrition rates from 30 percent to 22 percent and from 20 percent to 16 percent, respectively, following implementation of the screening battery currently in use. In the Academy screening phase, following the initial drop in Academy attrition rates due to the introduction of the selection battery, the Academy rates have climbed to 30 percent while field attrition has declined to 8 percent, indicating an early screening of potential failures in the program.

Based on the Aeronautical Center's budget office estimates, the present screening procedures provide a cost avoidance of conservatively 10.5 million per year or, more realistically, 13.8 million per year compared to the pre-selection-battery era. In human savings, the savings in time and effort for candidates that are screened out in 3-5 months as opposed to 3-4 years, are intuitively obvious. Further, while it is impossible to place an accurate value on human safety, it is a reasonable and logical inference to assume that an increase in the quality of personnel entering ATC and an increase in the quality of training could only result in an increase in the potential for the saving of human lives. CAMI screening research operates with the clear understanding that, as the U.S. Armed Services have discovered much to their dismay, sophisticated equipment is a must in our modern era, but the productive use of sophisticated equipment is extremely reduced unless it is manned by qualified and well trained personnel.

CAMI field research into the psychological characteristics of the full performance level (FPL) ATCS workforce covers two main areas: stress/anxiety

and job attitudes. The results of some of these studies may be summarized as follows.

The principal instrument we have employed to study psychological stress is the State-Trait Anxiety Inventory (STAI). Our findings, obtained in collaboration with CAMI's physiologists during on-site stress studies at towers and centers, show that ATCSs score significantly lower on this measure of psychological stress/anxiety than either college students or the normal adult population. Results of another test, a mood-adjective checklist, have verified these results. The findings also demonstrate an increase in anxiety across an eight-hour work shift for ATCSs. However, this result is not significantly different than reported anxiety across shifts for a variety of non-ATCS jobs, such as engineering. The general conclusions of these studies are that ATCSs are well within normal adult limits on psychological job stress, and that any deviation appears to be toward less anxiety than is average in other work settings.

We have conducted several surveys to assess job motivation and job attitudes. In general, what ATCSs find most positive in their job is the job tasks, the challenge of ATC work, and their pay. What they dislike most is management, work schedules, and job tasks not directly related to ATC work. These likes and dislikes are similar by category to those reported for other occupational groups. Thus, methods which are successful in improving job motivation and morale for other occupations are likely to be effective with controllers. Concerning shiftwork, the most negative attitude was toward the night shift and most ATCSs preferred a rapid turn-around shift rotation as opposed to spending a long time on one particular shift. Overall, approximately 90 percent of surveyed controllers were satisfied with their occupational choice, a proportion that is well above what the average worker reports for other occupations. Parenthetically, we have been collecting similar data on airway facilities personnel.

Present research in the psychological characteristics of FPL ATCSs includes research on system errors. System error refers to a violation of air traffic separation standards. Preliminary results indicate that approximately 90 percent of the system errors are a result of human error, while the errors are rather evenly distributed across the work shift, with the exception of the

last hour, errors tend to occur more frequently just after a position change-over, and the number of errors is related to the number of IFR operations at the facility, as opposed to the total number of aircraft operations. We are also currently involved in assessing the reactions of airway facilities personnel to the new maintenance concept being instituted on a national basis. Our research support in these air traffic and airway facilities tasks involves, of course, direct interaction with the FAA workforce in areas of primary and current interest.

Thank you.

RECESS

SESSION 2  
(July 7, 1981)

DR. DIEHL: We have a pretty lengthy group of distinguished speakers this afternoon.

Each of these individuals, I would add, will be in the one of the four workshops tomorrow, and they will have more to say in those workshops. However, because of their stature we thought that they should have an opportunity to talk to the entire group today.

So without further ado, I will introduce Richard G. Snyder. He is certainly one of the most widely published individuals in the area of aviation safety.

Dr. Snyder is a former Air Force instructor pilot. He earned a Ph.D. in Physical Anthropology at the University of Arizona in 1959. He was with CAMI from 1960 to 1966 before joining the Ford Motor Company to head their Biotechnology group. In 1968 he joined the University of Michigan. He is now a full professor and head of their Biomedical Department in the Highway Safety Research Institute.

He is the author of fourteen books and has published over three hundred articles. He is also currently a consultant to the Aircraft Owners and Pilots Association, to NATO and to various other government associations. And additionally, he is the chief investigator for the State of Michigan for their aircraft accident investigation program. Gerry is going to speak about human factors, the missing link in general aviation accident investigation.

DR. SNYDER: The human factors aspects of aircraft design and operation with respect to accident prevention include a wide variety of biomedical and behavioral areas. These have primarily been reported from military or civil air carrier viewpoints, with much less attention given to problems in general aviation. In this presentation I'd like to focus on... and question... the fundamental assumption of our human factors knowledge relative to general aviation aircraft accidents, and suggest a new approach and methods to improve our knowledge.

We all know that the problem is the pilot... or is it? "Pilot Error" has been almost universally cited as a prime causal factor in a high percentage of general aviation accidents.

Until December 1926 civil aircraft design, manufacture, and flight was completely uncontrolled, and accident data prior to that time is sketchy. However,



human factors in the form of pilot error was prominently reported in the very first Department of Commerce report on civil air accidents and casualties. For the year 1927, 200 accidents involving 313 injuries were reported, and "pilot error" was attributed to 78, or 48%, of the 164 fatalities.<sup>(1)</sup> Incidentally, only 34 of the 200 aircraft and four of the pilots were licensed. Charles Lindbergh, with four bailouts by 1927, typified the hazards of early flying. He was nearly grounded by the Department of Commerce just prior to his trans-atlantic flight in 1927.<sup>(2)</sup>

A recent NTSB analysis of factors associated with 17,312 general aviation single-engine fixed-wing accidents concluded that the pilot was found to be a cause or factor in 86% of the total accidents and 90% of the fatal accidents studied.<sup>(3)</sup> However, it was also observed that it was not possible to assess the significance of the pilot's role in these accidents because of the lack of appropriate "flight exposure data." The reason for this has often been overlooked and understated.

In 1978 there were 25 air carrier accidents (6 fatal with 163 fatalities). Most of those accidents were competently investigated to assess the role of human factors<sup>(4)</sup> (Table I). However, at the same time there were 4,609 general aviation accidents, 795 of which were fatal, with 1,690 fatalities. Only six of these -- four air commuters and two general aviation aircraft accidents -- were investigated by a member of the NTSB human factors team.<sup>(5)</sup> Excluding the mid-air collision at San Diego (25 September) between an air carrier and light aircraft, resulting in 155 fatalities, not one of the other 4,607 general aviation accidents is reported to have received any investigation by a Federal human factors specialist. In 1978 the NTSB investigated 985 aircraft accidents and significant incidents, including all in-flight collisions and all air taxi and air carrier accidents. The field investigations of 3,504 other accidents were delegated to the FAA.<sup>(4, p. 38)</sup>

Last year there were 20 air carrier accidents (2 fatal, with 14 fatalities) and 25 commuter accidents (4 fatal, with 19 fatalities). Fifteen (33%) of these were investigated for human factors data. But preliminary statistics show there were 3,799 total general aviation accidents, 677 fatal with 1,374 fatalities. Although NTSB field investigators investigated a total of 940 aviation accidents in 1980,<sup>(8, p. 11)</sup> only one aviation accident was reported to have received human factors investigation.

TABLE I. COMPARISON OF AIR CARRIER, COMMUTER, AND  
GENERAL AVIATION ACCIDENTS 1978-1980

	Total Annual H. F. Investigations	Air Carrier	Air Commuter	General Aviation
1978 (4,5)				
Accidents	<b>18</b> *	25	32	4,609
Fatal		6	9	795
Fatalities		163	42	1,690
		<b>12</b>	<b>4</b>	<b>2</b> **
1979(5,6)				
Accidents	<b>14</b>	26	32	4,051
Fatal		5	10	682
Fatalities		352	59	1,382
		<b>3</b>	<b>8</b>	<b>3</b>
1980(5,7,8)				
Accidents	<b>16</b>	20	25	3,799
Fatal		2	4	677
Fatalities		14	19	1,375
		<b>7</b>	<b>8</b>	<b>1</b>

\* The large figures refer to the number of NTSB Human Factors "go-team" investigations involving either air carrier, commuter, or general aviation categories of accidents. Data supplied by National Transportation Safety Board as referenced above. Note that in some cases these numbers include human factors investigation of accidents conducted in foreign countries of aircraft not listed in U.S. statistics.

\*\* For 1978 no general aviation accidents were reported investigated for human factors in the NTSB Safety Information Preliminary Data for 1978 release of 16 January 1979. Subsequently two cases have apparently been reclassified.

The statistics raise an obvious question. How can we assume that we know much of anything at all about human factors aspects of general aviation accidents if they are not investigated in depth by trained specialists? The high incidence of pilot error in the statistics should be treated with suspicion and many reservations.

This situation is often not the fault of the FAA GADO (General Aviation District Office) inspectors or NTSB field investigators. The entire NTSB presently has only four human factors specialists -- all in the Washington office -- and hardpressed to handle even a portion<sup>(15)</sup> of the 45 air carrier and commuter accidents which occurred in 1980. As a result they were able to investigate only a single "general aviation" accident last year. FAA maintenance inspectors, operations specialists, or even safety specialists seldom have been trained in human factors, and many have not even been trained in accident investigation. Only a handful of FAA employees are human factors specialists, and their duties primarily involve research and administration activities rather than routine field investigation.

A further problem is the time and resources required to conduct an in-depth accident study. Informed sources indicate that the FAA spends four hours on the average general aviation investigation, and the NTSB (which usually is only involved in fatal or major accidents) averages 15 hours. This is not sufficient time to get very far with a human factors study, no matter which area it is concentrated in. Even a major air carrier investigation is limited to 200 hours total human factors effort.<sup>(5)</sup>

Two weeks ago a serious crash (four injured) occurred in which the destroyed aircraft was "released" 20 minutes after the FAA arrived at the scene. It was loaded into trucks by a back-hoe, and transport from the scene was initiated within 90 minutes. In the case of on-airport crashes the airport management is usually anxious to remove the wreckage from sight.

It would be completely infeasible to cover every accident with a human factors study, even assuming sufficient numbers of experienced professionals could be found. Yet, some improvement over the zero-data base presently employed must be considered. One approach being tried by the NTSB and FAA is through more complete data collection forms. However, the success of this will ultimately depend upon the time, effort, and ability of the individual who presently is un-

able to fill in even the estimated impact velocity, attitude, or other environmental crash dynamics in 95% of the present "short" accident investigation reports.

There is yet another approach. During the past 12 years, selected general aviation accidents have been investigated by University of Michigan researchers, primarily for crashworthiness and to determine causation of occupant injury in order to recommend improvements in occupant crash protection.<sup>(9-18)</sup> This is similar in some respects to studies previously conducted at CAMI by John Swearingen<sup>(19)</sup> and the toxicological investigations which have been subsequently continued by Dr. Kirkham.<sup>(20)</sup>

We work in cooperation with the Michigan State Police and local FAA and NTSB investigators, but as a separate entity. It is generally not recognized that in the university environment experienced pilots can be found who are also specialists in a particular professional discipline. This provides a resource of unusual human factors talent, including not only psychologists and medical specialists, but anthropologists, industrial and operations engineers, and other specialists, including, in our case, a suicidologist.

While we have lacked support to demonstrate what an in-depth multi-disciplinary team effort could accomplish, we have studied selected accidents from the point of view of various human factors specialists.

Incidentally, with few exceptions, the human factors specialist should also be an experienced pilot. He can most fully understand the pilots' environment in reconstructing an accident. Pilots routinely experience problems that might never be recognized or considered by the non-pilot investigator. For example, on an IFR flight in the middle of turbulence, a right front seat passenger drops a glowing cigarette lighter and the pilot gets vertigo while trying to reach down to recover it. How many times have you hurried the landing, or even made an unscheduled landing, because you had a compelling call of nature? Could this explain why a pilot recently attempted a below-minimum landing on a field closed by weather, killing himself and three others?

The term "human factors" involves a wide variety of considerations, including control/display behavior, physical workspace environment, pilot training technique and judgment, physiopsychological and psychomotor factors, fatigue, and toxic and biomedical aspects (Fig. 1). In many accidents, pre- and post-

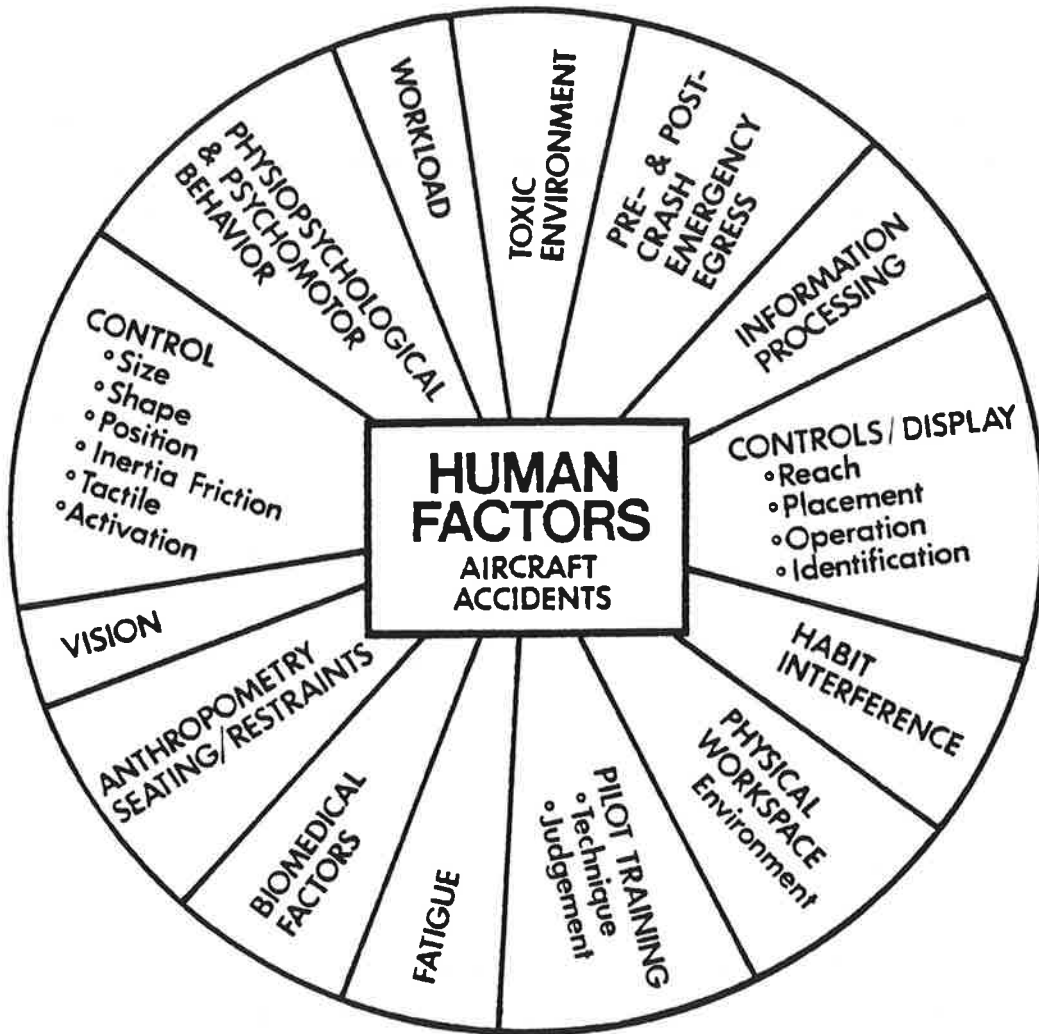

FIGURE 1. HUMAN FACTORS TYPICALLY INCLUDE THE ABOVE AREAS AS WELL AS A WIDE VARIETY OF OTHER CONSIDERATIONS. FEW PROFESSIONALS ARE TRAINED OR QUALIFIED IN MORE THAN A FEW AREAS, MAKING THE TEAM CONCEPT NECESSARY.

crash emergency egress is important. Usually none of these areas is considered in a general aviation accident investigation.

There is an extensive literature dealing with various aspects of human factors. Among studies of particular interest are the following. In Canada, Hemming has described the questions of a human factors investigation. He points out that "pilot error" is no longer an acceptable label.<sup>(21, p. 682)</sup> MacNamara et al.<sup>(22)</sup> has outlined a systematic model of the analysis of human factors in aircraft accidents. Lane<sup>(23)</sup> has discussed Australian human factors problems and techniques from the cost-benefit point of view. Burgin<sup>(24)</sup> has described the false hypothesis phenomenon, in which information processing and decision-making are not based upon all of the available facts. A variety of medical aspects of human factors described by Mohler<sup>(25)</sup> and Dille and Morris<sup>(26)</sup> require the cooperation of a number of medical specialities. Barron<sup>(27)</sup> has reviewed psychophysiological and environmental factors assessed in investigations of military accidents. Miller<sup>(29)</sup> has described a number of approaches and reiterated recommendations regarding the value of human factors investigators in aircraft accident investigation. This is a highly recommended comprehensive analysis which also provides a useful bibliography.

Under FAA contract a recent study<sup>(30)</sup> identified and analyzed 35 human factors design issues related to the major performance problems of general aviation pilots. Some crashes involve extremely complex human factors and require a multidisciplinary team approach for adequate analysis.

Typical human factors problems can be illustrated from our studies to date. For example, at 4:10 a.m. a Beech D-18S crashed onto an ice-covered lake while attempting an ILS final approach to the runway 1/4 mile away. The crash was non-survivable to the two pilots, and the cabin and cockpit were destroyed by post-crash fire. Weather was IFR with a ceiling of 300 feet and 1-1/4 mile visibility reported the previous hour, with light rain and fog at the time of the crash.

Among human factors items developed: FATIGUE - the pilot had flown 15 hours 12 minutes without rest. The flight had started 23-1/2 hours previously, with landings at five airports in two countries. (Another pilot in the same type aircraft under similar flight conditions had admitted to falling asleep on final in an earlier crash at the same airport). DESPONDENCY: The pilot was

divorced with seven children, and his engagement to another woman had just been called off. He had a complicated personal life, and may have also had medical problems.

The COPILOT was not qualified or checked out in the aircraft, was on the flight to build time, and reportedly had recently failed an instrument check.

Both occupants were ejected, and there was some question as to who was flying. A laceration on the left hand of the copilot could indicate that the copilot had his hand on the throttle. At impact the aircraft was to the right of course and turning away from the runway in a right turn. To further complicate matters, it was reported by a witness that the runway lights were out at the time of the accident, but these are automatically reset in the event of a power failure and supposedly could not have been out more than 1-1/2 seconds. There were also two pilots reports of brief high wind conditions and "wind shear" between 2:00-4:00 a.m., with branches blown off a tree located at the outer marker. In this case, there were multiple contributing factors.

Within the past two years there have been at least three suicides by aircraft in Michigan. These are often difficult to determine, and even where evidence is overwhelming, generally such cases are listed as accidental by the medical examiner.

Of major concern among medical factors is the question of the role of alcohol and drugs in general aviation aircraft accidents. At present some medical information is available on a reported 80% of pilots involved in accidents, and approximately 65-70% of pilots fatally injured in crashes undergo some form of autopsy.<sup>(20)</sup> However, to date very limited information is known for the vast majority of crashes where the pilot is not fatally injured. Therefore, no toxicological information is obtained. This represents a large unknown in biomedical human factors. The impending implied consent requirements (which would require any pilot receiving a medical certificate to allow a blood sample to be taken after involvement in an accident) will be an important and long-needed means to obtain information on the incidence and influence of alcohol and drugs in accidents.

Several studies have documented that there are "design-induced errors" related to many accidents, which may be attributed to pilot error. In one CAMI study,<sup>(31)</sup> for example, it was found that in two models of aircraft comparable

in performance, the gear and flap handles found in one model were reversed in the second. Habit interference involving switch and control confusion has also been reported by Lane<sup>(23)</sup> in an Australian study. Accidental activation of one control when reaching for another can occur when controls are spaced too closely together or when they are left unguarded. Use of the wrong controls or improper setting of a control implies that the operator does not receive sufficient feedback to recognize the mistake. Aircraft-design-induced pilot error can be masked without adequate human factors investigation, as described by Miller.<sup>(32)</sup> Major studies include the U.S. Army Handbook of Inadequate Aircraft Design,<sup>(33)</sup> and a study by the Bureau of Safety, Civil Aeronautics Board.<sup>(34)</sup> More recently an AOPA (Aircraft Owners and Pilots Association) article on cockpit standardization has reviewed current examples.<sup>(35)</sup>

It has frequently been found that an accident may occur as a consequence of a number of factors coinciding, which, had they occurred separately, would not have caused the accident. Such human factors are not easily detected.

Aircraft occupants are often injured post-crash, either in the course of egress or because they are unable to evacuate. One technique we have adapted in selected crash investigations involves a physical task analysis. The purpose is to demonstrate how possible human factors problems can be identified. The task analysis is performed in four steps (Table II). The first step is to group into functionally distinct tasks the activities required to exit the aircraft. In the case of the Gates Learjet 35A, (Fig. 2) for example, nine tasks have been identified in order for the flight crew to exit.

Secondly, the tasks are divided into elements that correspond to each movement. Ten elements are required for the crew to open the main door, and 17 to exit via the top hatch or rear window. Using floor plans and actual measurements, the third step is to determine the physical capabilities required to egress (Table III). In the case of the Learjet 35A the flight crew must enter the main cabin in a stooped posture, turn and reach for the handle, swing open the top half of the cabin door, then open the bottom door.

The pilot must travel ten feet, stooped no higher than 52 inches, exert a force of 38 pounds on the latch at a distance of 24 to 37 inches in front of the body and 27 inches above the floor.



TABLE II. THE BASIC TASK AND ELEMENTS REQUIRED FOR THE FLIGHT CREW TO EVACUATE A TYPICAL BUSINESS JET AIRCRAFT (SHOWN IN FIGURE 2). THE DASHED LINE SHOWS THE SEQUENCE FOR A CASE WHERE THE MAIN DOOR COULD NOT BE OPENED.

PILOT & COPILOT EGRESS PROCEDURE

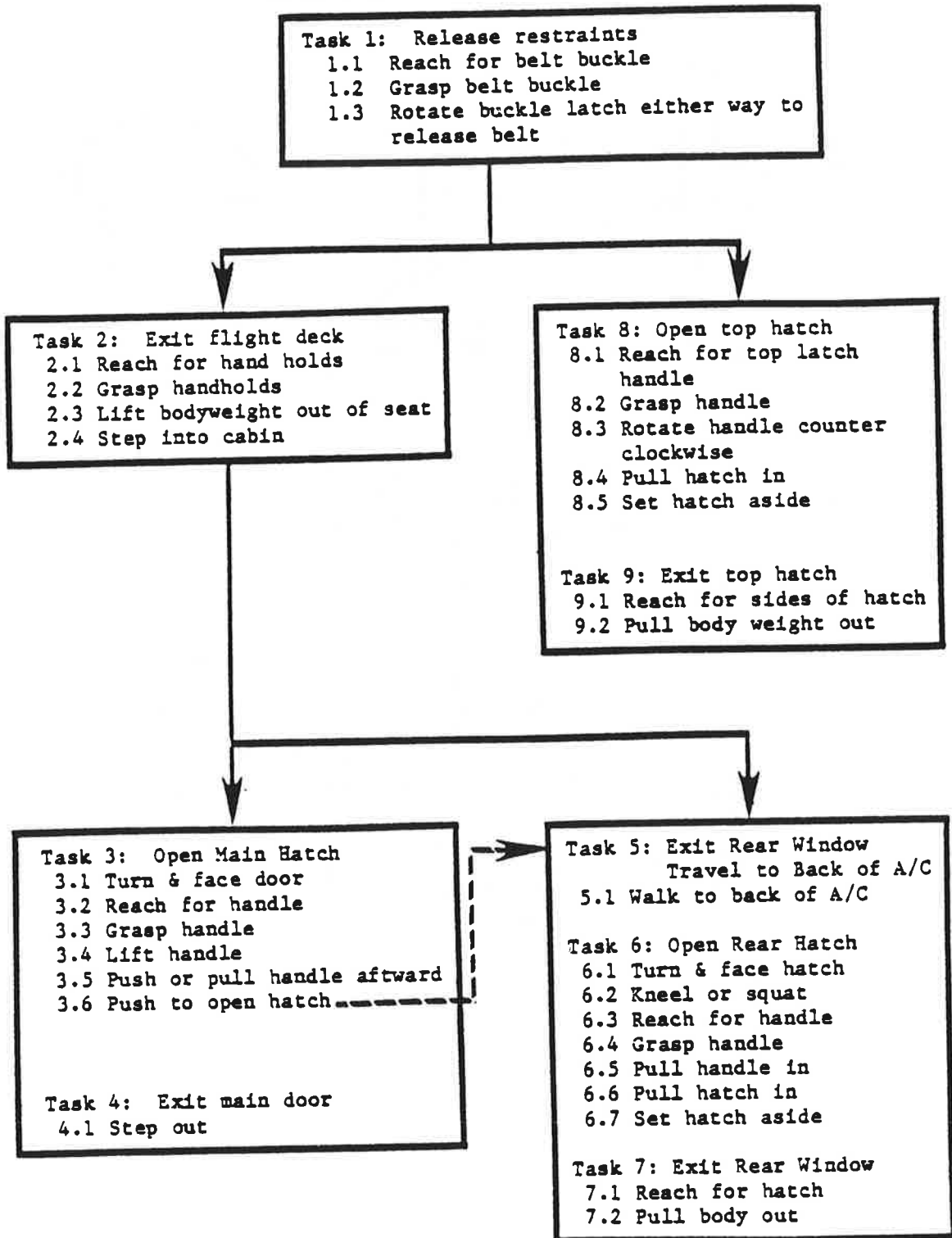

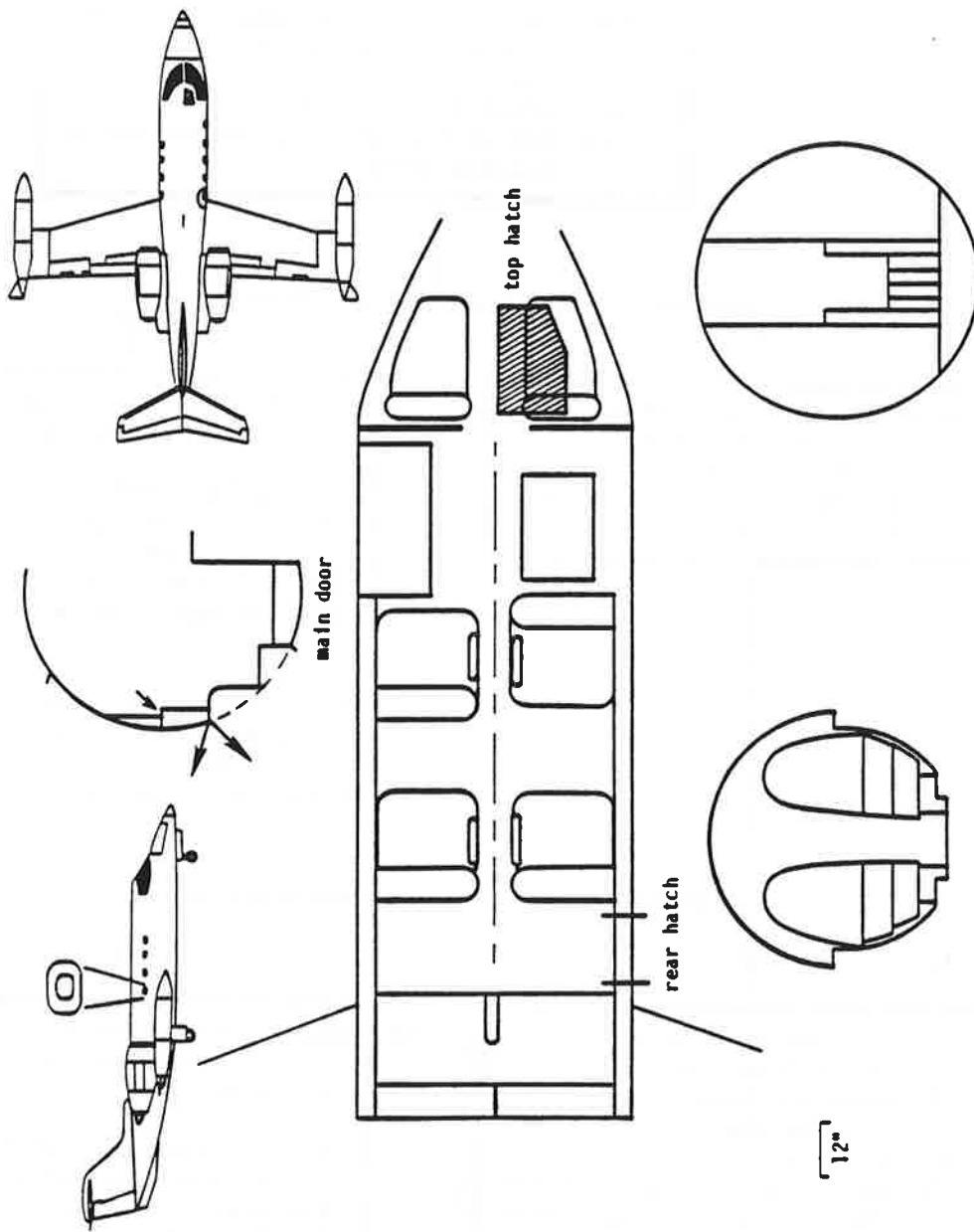

FIGURE 2. A SKETCH OF THE FLOOR PLAN IS USED TO FACILITATE ANALYSIS OF EGRESS PROCEDURES

TABLE III. REACH AND STRENGTH REQUIREMENTS TO REACH THE MAIN DOOR (SEE FIGURE 3) LATCH HANDLE AND OPEN IT - TASK 3.

Occupant Orientation	Latch Position & Exertion	Distance (inches)*			Force (lbs)	%Strong Enough	
		Vert.	Horiz.	Lat.		Males	Females
Facing Door	Closed-Lift	26	24-30	6	37	61-85	6-18
	Mid-Pull Left	29	24-30	4	44	79-97	2-15
Facing Forward	Closed-Lift	26	15	14	37	98	57
	Mid-Pull Back	29	13	14	44	95	61

Figure 3 shows a 5th-percentile female and 95th-percentile male in position required to open the door. Note how access is restricted by the curvature of the fuselage and the step on the lower half of the door. Reaching for the handle could be facilitated if handles on the top and side of the aircraft were provided for the occupants to hang onto while reaching for the latch handle.

The fourth step of task analysis is to compare the physical requirements with the physical capability of the persons who are expected to do the tasks. To open this latch requires a vertical force of 38 pounds. Computer simulations show that over 15 percent of the male population and 90 percent of the female population would have difficulty opening this door. They would have to get closer, use two hands, pry with their body, or get help. From 3 to 21% of the male population and 85 to 98% of the female population would have difficulty pushing this handle sideways from mid to open position. These conditions could be expected to worsen under crash conditions.

In a previous paper we have illustrated how alternative designs and procedures would improve the emergency egress of this particular door.<sup>(37)</sup> While use of a physical task analysis in aircraft accident investigation is an important technique, it is even more important that it be utilized as a tool by the designer during the original design process.

In summary, greater attention must be given to the investigation of human factors aspects of general aviation accidents. During the past three years, while 12,459 general aviation accidents have occurred, the NTSB subjected only six of these to human factors investigations. If only one in 2000 general aviation accidents is investigated for human factors, surely we yet have much to learn. The high percentage now superficially attributed to "pilot error" may be found on closer study to include and mask design-induced and other factors as well. Studies conducted by the University of Michigan during general aviation accident investigations have shown that there are resources and methods as yet unused. One approach - that of physical task analysis - is suggested as an additional way to provide valuable insight into human factors aspects not presently considered.

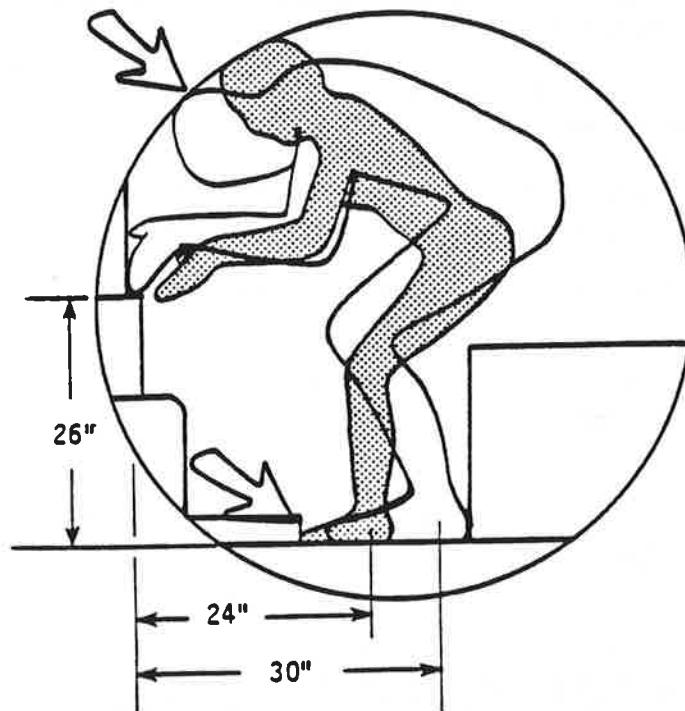

FIGURE 3. A SIDE FACING FIFTH PERCENTILE FEMALE AND NINETY-FIFTH PERCENTILE MALE OCCUPANTS ARE SHOWN REACHING FOR THE LATCH TO OPEN THE UPPER HALF OF THE MAIN DOOR (21). NOTE HOW ACCESS IS RESTRICTED BY THE CURVATURE OF THE FUSELAGE AND THE STEP ON THE LOWER HALF OF THE DOOR.

## REFERENCES CITED

1. Department of Commerce "Civil Air Accidents and Casualties" Aeronautics Branch. Washington, D.C. Information Bulletin No. 30. March 10, 1928.
2. Time "They Almost Grounded Lindy" p. 24, November 28, 1977.
3. National Transportation Board Special Study. Single-Engine, Fixed Wind General Aviation Accidents 1972-1975. Report NTSB-AAS-79-1, May 31, 1979.
4. National Transportation Safety Board Annual Report to Congress 1978. 30 March 1979.
5. Personal communication. Human Factors Branch, National Transportation Safety Board, Washington, D.C. 3 July 1981.
6. National Transportation Safety Board "Aviation Safety" Annual Report to Congress 1979. pp. 9-21. January 24, 1980.
7. National Transportation Safety Board Safety Information Release of January 13, 1981.
8. National Transportation Safety Board Annual Report to Congress 1980 January 27, 1981.
9. Snyder, R.G. "Crashworthiness and Occupant Protection in General Aviation Aircraft Accidents." Proceedings, Second International Meeting Aerospace Medicine, Melbourne, Australia, October 30, 1972.
10. Snyder, R.G. "Crashworthiness Considerations in Design of General Aviation Aircraft." The Consumer Factor. Proceedings of the Seventeenth Annual Meeting of the Human Factors Society (M.O. Ranc, Jr. and T.B. Malone, eds.), p. 222, Washington, D.C., October 1973.
11. Snyder, R.G. "Crashworthiness Investigation of General Aviation Accidents." The Society of Air Safety Investigators Forum, pp. 4-5, 20-24, Fall 1975.
12. Snyder, R.G. "Crashworthiness Investigation of General Aviation Accidents." National Business Aircraft Meeting, Society of Automotive Engineers, Inc., New York, Publication No. 750537, 1975.
13. Snyder, R.G. Field Experience Relative to Forensic Science Investigation of Fatal General Aviation Aircraft Accidents, panel on "The Forensic Sciences in Aircraft Accident Investigation." American Academy of Forensic Sciences, Washington, D.C., February 1976.
14. Snyder, R.G. "Injury and Fatality Causation in Survivable Michigan Accidents 1969-1975." Proceedings, Joint Committee on Aviation Pathology, RAF Halton, England. September 1976.

15. Snyder, R.G. "Civil Aircraft Restraint Systems: State-of-the-Art: Evaluation of Accident Experience, Experimental Data, and Standards." Society of Automotive Engineers, Technical Publication #770154 (reprinted SAE Transactions, 1978), February 1978.
16. Snyder, R.G. "General Aviation Crash Survivability." Society of Automotive Engineers, Technical Publications 780017, SAE Transactions, Vol. 87, February 1978.
17. Snyder, R.G. Occupant Injury Mechanisms in Civil Helicopter Accidents. AGARD/NATO, Operational Helicopter Aviation Medicine, AGARD Conference Preprint, pp. 6.1-1/66.14, May 1978.
18. Snyder, R.G. and Armstrong, T.J. "Crashworthiness Analysis of Field Investigation of Business Aircraft Accidents." Business Aircraft Meeting and Exposition, Society of Automotive Engineers, Technical Publication No. 790587, April 1979.
19. Swearingen, J.J. General Aviation Structure Directly Responsible for Trauma in Crash Decelerations. Special Report. Federal Aviation Administration, Office of Aviation Medicine, Washington, D.C. Report FAA-AM-71-3. January 1971.
20. Kirkham, W.R. What Does Medical Investigation of Aircraft Accidents Reveal? 5th Annual Human Factors Workshop on Aviation: Biomedical and Behavioral Factors in Aviation. U.S. Department of Transportation, Federal Aviation Administration, Mike Monroney Aeronautical Center, Oklahoma City. 7 July 1981.
21. Hemming, F.O. "Aircraft Accidents and Human Factors" Technical Notes. Aerospace Medicine pp. 682-684. June 1973.
22. Macnamara, W.D., W.J. McArthur, and P.J. Desn "A Model for the Analysis of Human Factors in Aircraft Accidents" Proceedings, Aerospace Medical Association, Bal Harbour, Fla. pp. 236-237. May 1972.
23. Lane, J.C. "Human Factors in Transportation." Proceedings, 10th Annual Conference of the Ergonomics Society of Australia and New Zealand. Snyder, Australia. November 1973.
24. Burgin, R.E. False Hypothesis and the Pilot Air Transportation Meeting, Boston. SAE Paper 780528. May 1978.
25. Mohler, S.R. The Predominant Causes of Crashes and Recommended Therapy. Federal Aviation Agency, Office of Aviation Medicine. Report No. 68-8. April 1966.
26. Dille, J.R. and E.W. Morris "Human Factors in General Aviation Accidents" Clinical Aviation and Aerospace Medicine. Aerospace Medicine 38(10):1063-1066. October 1967.

27. Barron, C.I. "Human Factors in Aircraft Accident Investigation: Physiological and Pathological Factors" Course Outline, University of Southern California, 1974.
28. Klinestiver, L.R. Psychophysiological and Other Factors Affecting Human Performance in Accident Prevention and Investigation. Proceedings, 18th Annual SAFE Symposium, San Diego. October 1980.
29. Miller, C.O. "Human Factors in Accident Investigation" ISASI Forum 13(1):16-25. Spring 1980.
30. Shelnutt, J.B., J.M. Childs, W.W. Prophet, and W.D. Spears Human Factors Problems in General Aviation Federal Aviation Administration Technical Center, Atlantic City, conducted by Seville Research Corporation, Pensacola, under subcontract to Emby-Riddle Aeronautical University, Daytona Beach. FAA Report FAA-CT-80-194, April 1980.
31. Pearson, R.G. Human Factors Engineering for Aircraft Accident Prevention Symposium, "Psychological Autopsy of Aircraft Accidents," American Psychological Association, Miami Beach. September 4, 1970.
32. Miller, C.O. "The Design-Induced Part of the Human Error Problem in Aviation." Journal of Air Law and Commerce 42:119, 1976.
33. U.S. Army Board for Aviation Accident Research Handbook of Inadequate Aircraft Design Fort Rucker, Oklahoma. 1964.
34. Civil Aeronautics Board Aircraft Design-Induced Pilot Error. Bureau of Safety, Washington, D.C. July 1967.
35. Schiff, B. "Cockpit Standardization" AOPA Pilot 23:41-44. July 1980.
36. National Transportation Safety Board Safety Information Preliminary Data for 1978. Washington, D.C. 16 January 1979.
37. Armstrong, T.J. and R.G. Snyder Human Factors Aspects of Emergency Egress from a Business Jet. Society of Automotive Engineers, Inc. Business Aircraft Meeting and Exposition, Wichita. SAE Paper 810617. April 1981.



DR. DIEHL: I certainly want to thank Gerry for a most informative talk. Our next speaker is Dr. Stan Roscoe and like Gerry Snyder, Stan needs no introduction.

He is currently Head, Behavioral Engineering Laboratory at New Mexico State University. He is also President of the Illiana Aviation Sciences Corporation, which is a private research consultant firm.

He has also long been associated with the University of Illinois. He received his Ph.D. in Engineering Psychology from Illinois in 1950. Shortly thereafter, in 1952, he joined the Hughes Aircraft Corporation where he was instrumental in developing a number of advanced display systems. In 1969 he returned to Illinois to set up the Aviation Research Laboratory there. Stan is a Fellow of the Human Factors Society and past president of that society.

He has been a recipient of three awards from the Human Factors Society, the Ely Award, the Fitts Award and the Williams Award. In addition, he is a Fellow of the Royal Aeronautical Society.

Stan is also the author of what must be the best-selling book in aviation psychology. Stan will be talking about neglected human factors aspects and aviation. He will be reading a prepared paper.

## NEGLECTED HUMAN FACTORS

Stanley N. Roscoe  
New Mexico State University

Misjudgments of position in flight and failures to detect other airborne traffic are casualties of the eternal tug-of-war between visible texture and the pilot's dark focus. The eye is lazy and resists the pull of a distant stimulus, preferring to rest at a relatively short focal distance as it does in the dark or when looking at the sky. Judgments of apparent size are highly correlated with visual accommodation distance, and the difficulty of detecting airplanes on stationary collision courses is greatly aggravated when focus is trapped by structure close to the eyes. Subject, cockpit design, task, and environment variables all interact to determine what we think we see.

During the history of experimental psychology a vast literature has emerged on our ability to detect things and our so-called constancies in judging their shapes, sizes, and distances. Among the many human factors in aviation, these abilities are particularly critical. Yet there is surprisingly little communication between investigators of the psychology of vision, the designers of airplanes, and the operational types who select and train flight crews. How we judge position and motion relative to airport runways and other surface objects, and how we detect other airplanes, especially those on collision courses, are among the most seriously neglected human factors in aviation system design, training, and operation.

### JUDGING SIZE AND DISTANCE

In 1950 at the University of Illinois it was discovered that airplane pilots making landing approaches by periscope come in high and land long and hard, unless the image of the scene is magnified by about 20 to 30 percent (Roscoe, 1950; Roscoe, Hasler, and Dougherty, 1966; see Figure 1). In 1973 Everett Palmer at NASA-Ames Research Center in California experimentally confirmed the common observation that pilots also make high approaches and long, hard landings in flight simulators with contact visual systems (Palmer and Cronn, 1973). Similar misjudgments occur with helmet-mounted imaging displays. Why is it that either real or virtual images projected at unity magnification cause objects such as airport runways to appear smaller and farther away than when viewed directly?

In 1975 Robert Randle of NASA-Ames Research Center and this author set out to find answers with the expert help of Robert Hennessy, now of the US National Research Council, and a gaggle of graduate research assistants at San Jose State University in 1975-77, the University of Illinois in 1977-1979, and New Mexico State University in 1979-81. Together we discovered a correlation of 0.9 or greater between the apparent, or perceived, size of objects subtending a given visual angle and an observer's visual accommodation--the distance to which the eyes are focused (Roscoe, 1979a, 1979b; see Figure 2). This finding runs directly counter to accepted theory.

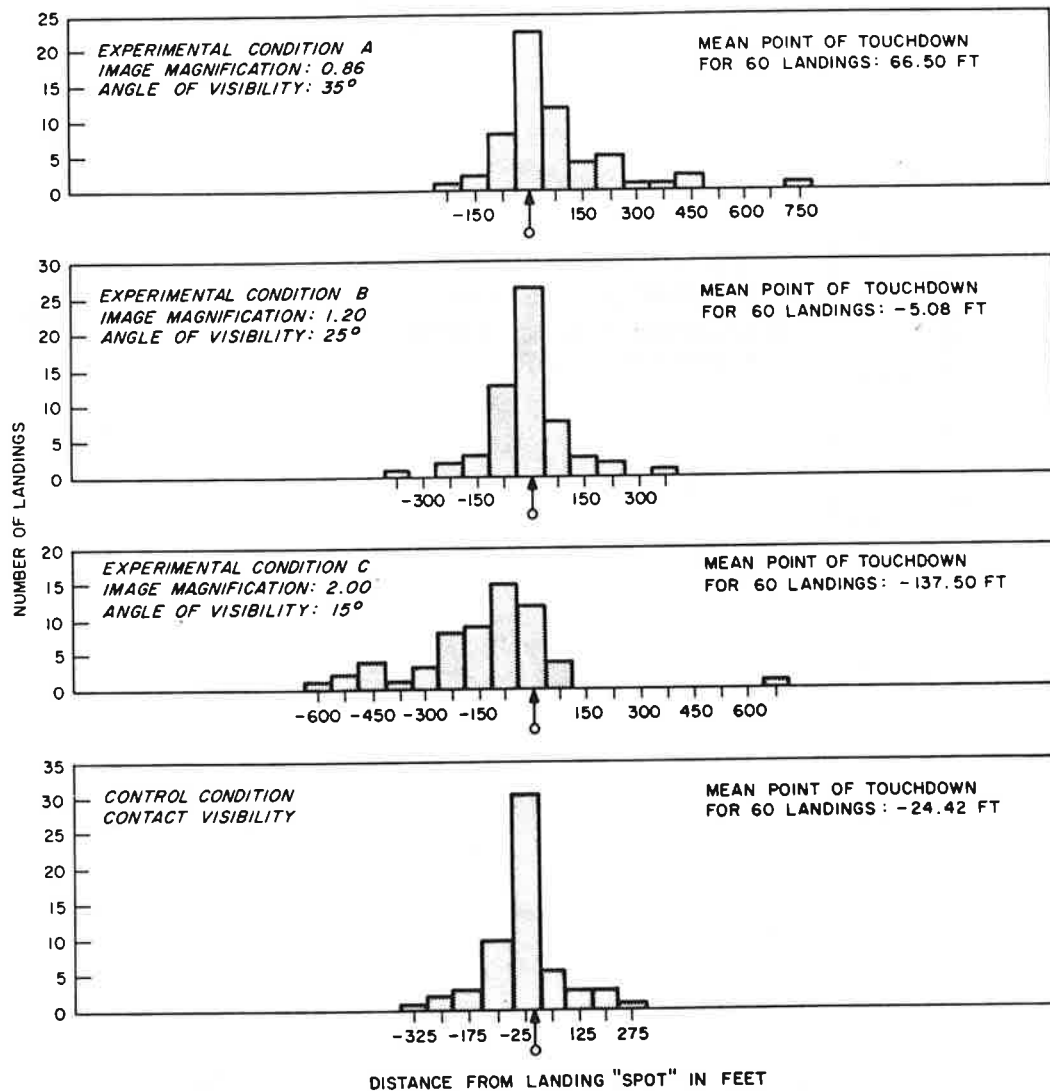

Figure 1. Distributions of points of touchdown for 60 landings (10 by each of 6 pilots) in four experimental conditions, three involving periscope magnification factors of 0.86, 1.20, and 2.00 and the fourth providing contact visibility. With x2 magnification pilots touch down short of the aimpoint and unexpectedly; with image minification they round out high and land long and hard; at x1.2 the distribution of touchdown points is virtually indistinguishable from that for contact visibility. (Roscoe, Hasler, and Dougherty, 1966)

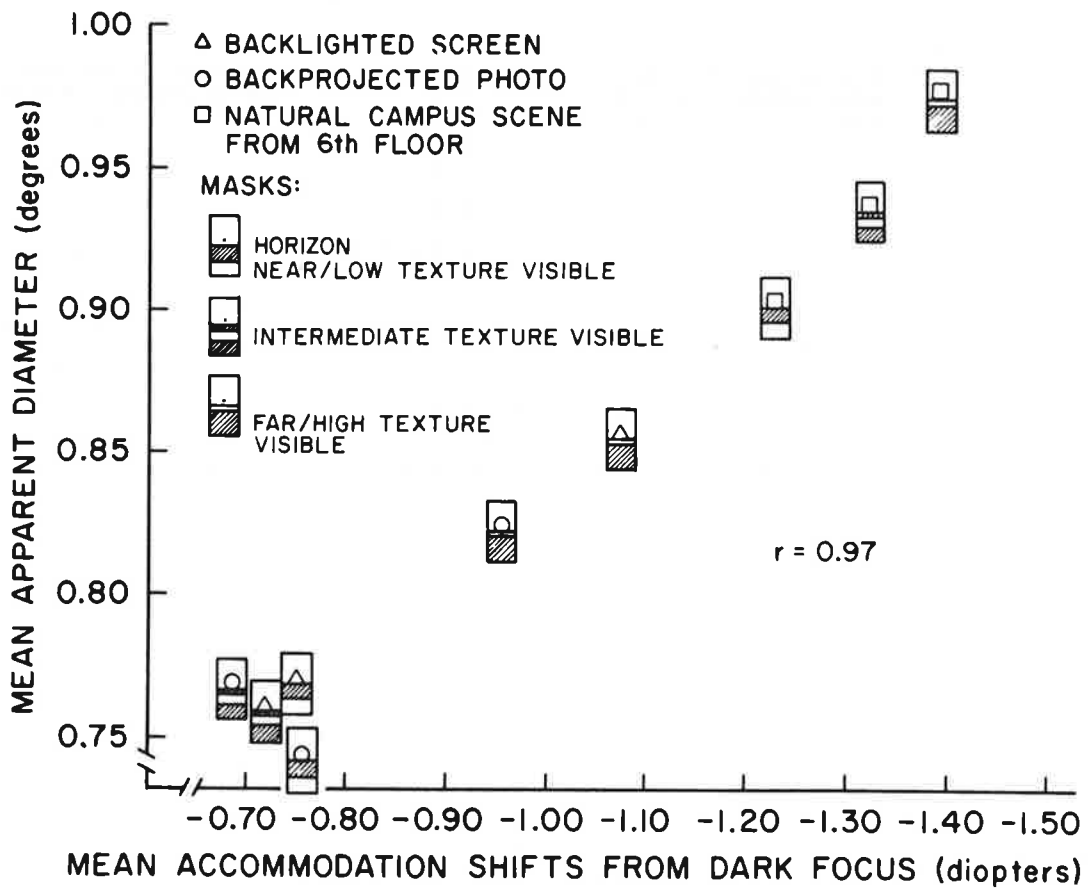

Figure 2. Mean apparent diameter of the simulated moon as a function of mean accommodation shift from individual dark-focus distances for eight observers viewing the moon against three different backgrounds (scenes), each differentially obscured by a series of three masks that induced further shifts in visual accommodation and apparent size. (Hull, Gill, and Roscoe, in press).

Perhaps it is not surprising that a relationship between perceived size and eye focus for distances well beyond the near limit of "optical infinity" went undiscovered for so long. Stimulus distances normally included in laboratory experiments do not approach those from which pilots view the world below them in flight. Indeed, few laboratory experiments in which eye focus was actually measured have involved distances of more than a few meters. But now that a strong relationship between the distance of eye focus and apparent size has been established, other mysteries of visual perception and illusion in flight become fair game for reassessment.

For example: Why do pilots making landing approaches over water at night toward a brightly lighted city consistently come in low (Kraft, 1978) and sometimes land in the bay short of the runway? This has happened in Tokyo, San Francisco, Los Angeles, Salt Lake City, and so it goes. Why is it that military pilots making ground attack runs so often fail to pull up in time and fly into the terrain in clear daylight? And why, in a group of pilots with "normal" vision, will some spot "bogies" so much sooner than others?

#### BACKGROUND

Before suggesting answers to such questions, some background is in order. By 1970 Randle had developed a classical Pavlovian conditioning technique, employing automatic biofeedback of focusing responses, to study the extent of possible voluntary control of accommodation. Randle's initial purpose was to teach children how to avoid becoming myopic. Then during the early 1970s, Hennessy, working with his mentor, Herschel Leibowitz, and fellow graduate student, Fred Owens, at The Pennsylvania State University, greatly extended our understanding of the "anomalous" empty-field, night, and instrument myopias and clarified the role of the dark focus, or relaxed accommodation, of the eye.\*

Then, between 1975 and 1981 at Ames Research Center, the University of Illinois, and New Mexico State University, 23 experiments were conducted involving the relationships among visual stimulus variables, eye accommodation, and associated perceptual responses.\* There is no longer any question that this line of investigation is of great importance to aviation. Among the many findings, the following stand out as contributing to our understanding of why pilots often misjudge sizes and distances and fail to see and avoid other aircraft in flight:

---

\*Though not cited individually here, reports of these experiments are included in the references at the end of this chapter.

1. Judgments of size, and by inference the distance, of objects in natural outdoor vistas are strongly dependent on the distance to which the eyes are focused ( $r > 0.9$ ).

2. Accommodation to natural vistas depends in a complicated way on the dark focus\* of the individual, the retinal locus and spatial frequency of visible texture (Benel, 1979), and the sharpness of focus needed for the discrimination of object identity, for example, reading a sign (Simonelli, 1979).

3. Individual differences in dark focus range from perhaps 15 D (7 cm) in extremely myopic people to as distant as -4 D (far beyond "optical infinity") in the extremely hyperopic; the more distant the individual's dark focus, the greater his or her tendency to focus beyond an acuity target to maximize apparent size for the discrimination of detail (Simonelli, 1979; see Figure 3).

4. Some individuals can be trained more readily than others to control the focal distance of their eyes voluntarily; there is some evidence that such trainability depends in part on the individual's dark focus and that both the selection and training of pilots should take such characteristics into account.

#### THE MOON ILLUSION REVISITED

A convenient way to study perceptual responses to the distant vistas seen in contact flight is to use a technique developed by Lloyd Kaufman and Irvin Rock (1962) to quantify the moon illusion. By superposing a collimated disk of light on any natural outdoor or laboratory scene and providing an adjustable-diameter comparison disk nearby, surprisingly consistent estimates of the apparent size of the simulated "moon" can be obtained. An adaptation of the Kaufman and Rock technique (known affectionately as "the moon machine") has been used in a series of experiments to correlate measured eye accommodation, judgments of apparent size, and characteristics of both natural and artificial visual scenes (Roscoe, 1979b).

These experiments have shown that with both natural and artificial scenes, whether in daylight or at night, when viewing conditions cause the eyes to focus near, the moon shrinks, and when they cause distant focus, the moon grows (Iavecchia, Iavecchia, and Roscoe, 1978; Simonelli and Roscoe, 1979; Benel, 1979; Hull, Gill, and Roscoe, 1979). Whatever the causal explanation may turn out to be, this invariant relationship appears to be the key to many of the misjudgments experienced by pilots. Such misjudgments can cause pilots to land in the water at night, fly into the terrain or overshoot a runway in the daylight, or fail to see and avoid another airplane on a collision course.

---

\*The distance at which the eyes focus in an empty field such as a clear sky is very close to the distance at which they come to rest in the dark.

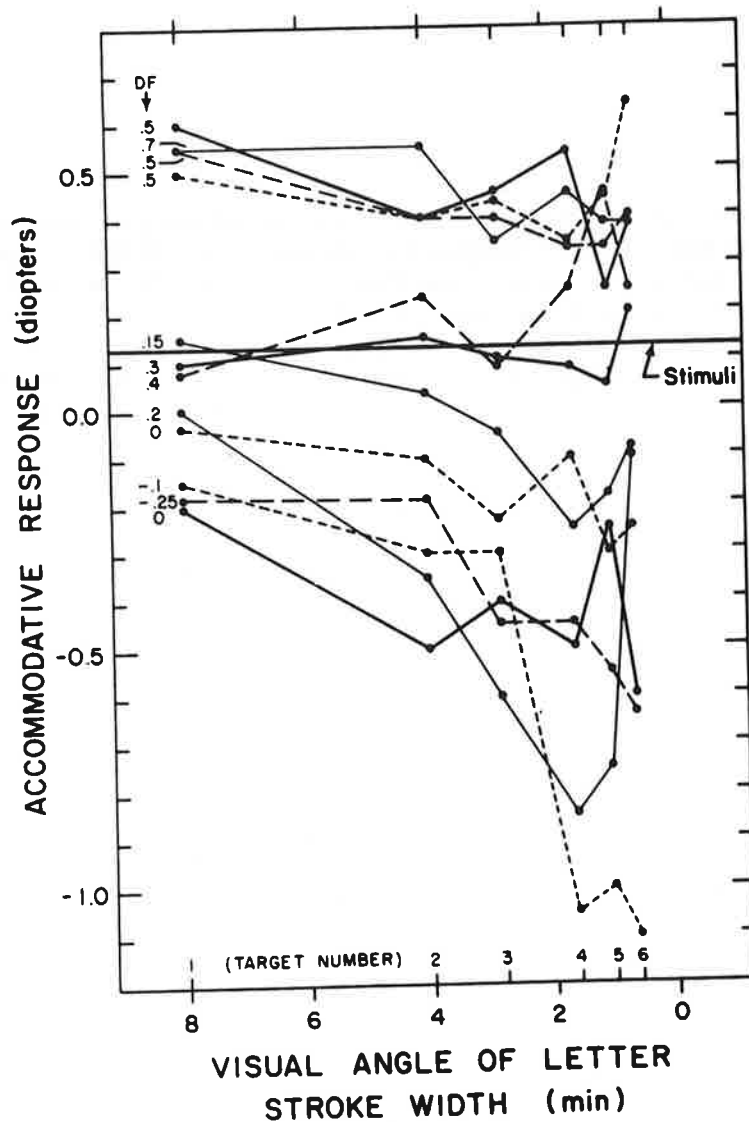

Figure 3. Individual visual accommodation responses to Snellen letters of various sizes presented at a fixed distance of 7.6 meters under constant illumination of 1.3 ftL. As the letters become smaller and harder to read, observers with more distant dark focus levels accommodate farther and farther beyond the targets for maximum acuity; observers with nearer dark focus levels do not exhibit this zoom-lens effect.

## CRITICAL VARIABLES

Viewing conditions that induce shifts in focus either outward or inward from the dark focus include subject, cockpit design, task, and environment variables as well as the distribution of visible texture.

### Subject Variables

Differences in perceptual abilities among people qualifying as having normal "20/20" vision are staggering (Simonelli, 1979). Some are surprisingly nearsighted while some have the ability to focus -4 D beyond "optical infinity," much like a zoom lens of a TV camera. A US Air Force recruit, when told by Nicholas Simonelli that he had remarkable vision, said, "Yes, Suh, I can tell the color of a frog's eyes at 100 paces." The recruit was not bragging; his acuity was on the order of 20/10 and his dark focus and far point well into the negative range.

Eye accommodation is a tug-of-war between the stimulus and the dark focus, with the stimulus normally pulling just hard enough to be seen and recognized. Simonelli refers to this as the "acuity demand" of a stimulus. As we walk, drive a car, or fly low over the terrain, our accommodation is determined largely by Gibson's (1950) well-known "texture gradient." The retina unconsciously performs some kind of an averaging routine on the textural elements to reduce the blur, and the fact that much of the scene necessarily remains blurred normally goes unnoticed so long as the acuity demand remains low.

In daylight the gradient extends uninterrupted from the nose and other parts of the body to the near foreground and on out to the distant horizon. But from the cockpit at night, and even in daylight at higher altitudes, the gradient is not uninterrupted. Between nearby cockpit surfaces and the outside visible texture the gradient is interrupted by empty space. Even clouds are effectively textureless in that they present little acuity demand, and at night the outside texture is limited to a thin horizontal band of point light sources. Now this is where individual differences in dark focus can cause giant misperceptions.

If a pilot's dark focus is at about arms' length, normal for young healthy eyes, he will experience empty field myopia in daylight, as well as night myopia. Empty field myopia is reinforced by the stimulus pull of window posts and frames, some of which are even nearer than arms' length. For example, we at New Mexico State University found that pilots focused at almost exactly the distance of window posts viewed against a sky background, even when a post was no wider than the 2-1/2-inch distance between the eyes, thereby supposedly causing no binocular obstruction to outside vision (Roscoe and Hull, in preparation).

Even though other traffic may be clearly visible, the effect of induced myopia is to blur the retinal image, reduce effective contrast, and make objects harder to see and apparently both smaller and farther away (Kraft,



Farrell, and Boucek, 1970; Roscoe, 1979a, 1979b). Targets can still be detected, particularly if they flash or glisten; or if they present an extended distinctive shape, such as a long, thin contrail; or if they move. However, another airplane on a collision course doesn't move, it only grows, slowly at first and then very rapidly, and it must subtend a visual angle of more than 8 minutes before it can be readily detected when badly out of focus (Luria, 1980).

Now for a different danger. If a pilot's dark focus is quite distant, possibly beyond optical infinity, and his attention is directed to the lights of a coastal airport and the city rising beyond, the visual scene can appear greatly magnified. The nearer lights of the runway threshold will expand downward from the horizontal band of city lights, thereby making it appear that the airplane is high on final approach. The pilot may compensate by reducing power and drop below the proper glideslope. At some point the low position will suddenly become apparent, and normally the pilot will add sufficient thrust to land safely; but with engines spooled down, thrust may come too late to avert the water landing.

#### Cockpit Design Variables

The pilot's legal requirement to "see and avoid" as a means of maintaining traffic separation in clear weather is at best an anachronism. At high subsonic speeds, head-on closing rates approach 1000 knots. That is about 17 nautical miles per minute, or one mile every four seconds. To avoid another airplane on a near head-on collision course, it must be picked up at a minimum of about three miles. Fortunately, at en route flight levels airplanes typically leave contrails that can be seen for many times that distance, so despite the undependability of the see and avoid concept, seeing and avoiding continues to save many lives every year.

Consequently, while few pilots count on seeing and avoiding, everyone does the best he can. Everyone except the manufacturers of airplanes, the regulatory agencies who certificate them, and the investigative agencies who determine the probable causes of midair collisions. Strong words? Perhaps, but objectively accurate in view of the routine certification of airplanes that do not meet nominal minimum cockpit visibility standards and the fact that officially approved deviations from such standards are never cited as contributing causes of pilot errors in midair collisions on clear, bright, sunny days.

Title 14 of the US Code of Federal Regulations, as revised in 1963, stated in part that no windshield post in the cockpit of a transport category aircraft shall "exceed 2.5 inches total obstruction in projected width on the pilot's eyes when located within a sector of 20 degrees and 60 degrees azimuth to the left of the pilot's forward vision . . ." This standard is based on the fact that 2.5 inches is the average distance between human eyes, and any window obstruction of greater projected width necessarily makes it possible for another airplane on a stationary collision course to be completely obscured to both eyes. Nevertheless, this standard is frequently violated in the design of transport category aircraft.

The DC-9, for example, has a window post starting 30 degrees to the left of the pilot's forward vision (and another to the right of the copilot) that exceeds the interocular distance by approximately two inches. It creates a binocular obscuration of almost 9 degrees, as shown in Figure 4, and a total sector of obstruction to one eye or the other of 31 degrees. Figure 5 illustrates the zones of monocular and binocular visibility from the DC-9 pilot's nominal eye position and compares these with the nominal standard. The solid black areas are supposed to be free of binocular obscuration.

Since 1967 the DC-9 has been involved in four midair collisions in clear daylight, resulting in 335 deaths, in which visibility of the other airplane was totally or partially obscured by the DC-9's oversized window posts. These midair collisions occurred over Urbana, Ohio, in 1967; Fairland, Indiana, in 1970; Duarte, California, in 1971; and Zagreb, Yugoslavia, in 1976. In none of these accidents was there any evidence that either the pilot or copilot saw the other airplane before the instant of impact. This was true despite the fact that the DC-9 crew was warned by ATC at least 15 seconds before the Urbana collision, and over Zagreb the other airplane, a Trident III, was leaving a seven-mile-long contrail at flight level 330 (33,000 feet) that was visible to other pilots in the area and should have been visible to the DC-9 pilot for at least three minutes.

But the DC-9 is not alone. Oversized posts can be found in the Boeing 747, the Lockheed L-1011, the Airbus, the Trident, and many other entries in this game of airway Russian Roulette. To investigate this problem, we measured the effects of simulated window posts 2-1/2 and 4-5/8 inches wide, and 12 inches in front of the eyes, on the probability of detecting simulated contrails at various elevations projecting various angular distances from the right or left edge of such a post (Roscoe and Hull, in preparation). With a 2-1/2-inch post, the probability of detection in a single fixation of 1/3 second ranged from 0.79 to 0.97 as the angular length of a contrail increased from 6 to 16 degrees to the right or left of forward vision, as illustrated in Figure 6.

With the 4-5/8-inch post (2-1/8 inches greater than the interpupillary distance), the probabilities of detection for corresponding contrails, also shown in Figure 6, plunged to 0.10 for 6 degrees (barely visible to one eye or the other at the right or left edge of the post) and gradually increased to 0.29 for 7 degrees, 0.55 for 9 degrees, 0.68 for 12 degrees, and 0.65 for 16 degrees. In addition to the total binocular obscuration caused by an oversized window post, the probability of detection of a contrail in the sectors of monocular visibility on either side is greatly reduced. Few pilots are aware of the danger caused by wide window posts a few inches from the eyes.

#### Task Variables

Pilots with normal visual functions can expect outward shifts in accommodation when task demands create elevated workloads and stresses.

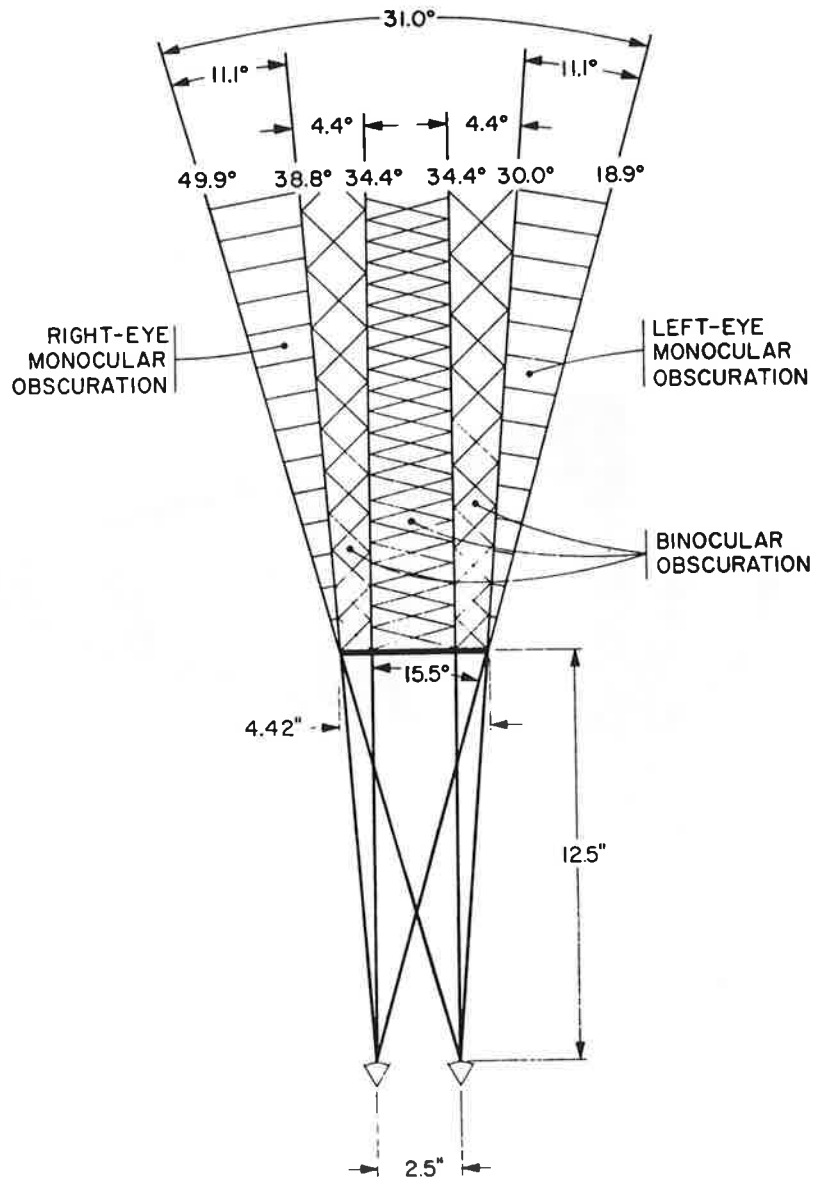

Figure 4. Visibility diagram showing sectors of monocular and binocular obscuration caused by a window post of 4.42-inch projected width 12.5 inches from pilot's eyes.

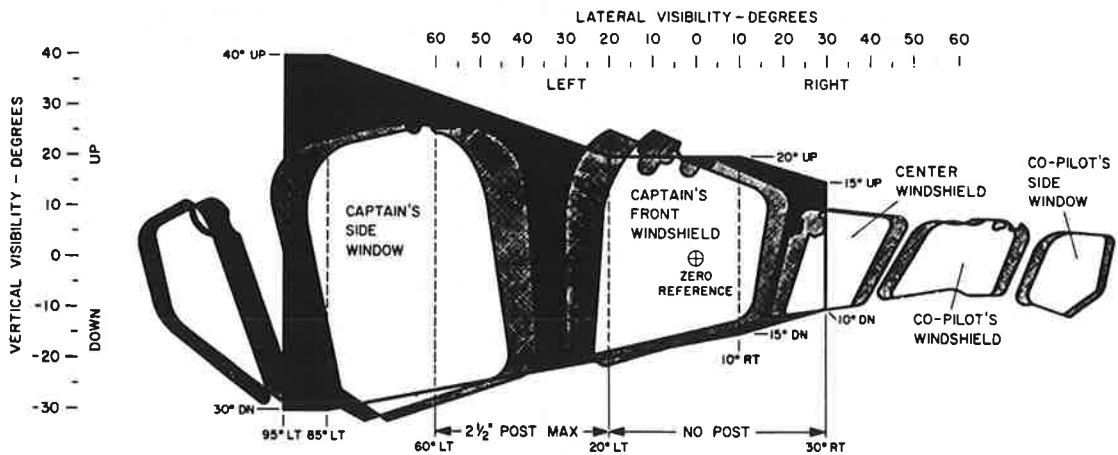

Figure 5. Comparison of DC-9 visibility with US Federal Aviation Administration nominal visibility standard. Solid dark areas indicate binocular visibility obscuration where none should exist; shaded areas indicate monocular obscuration.

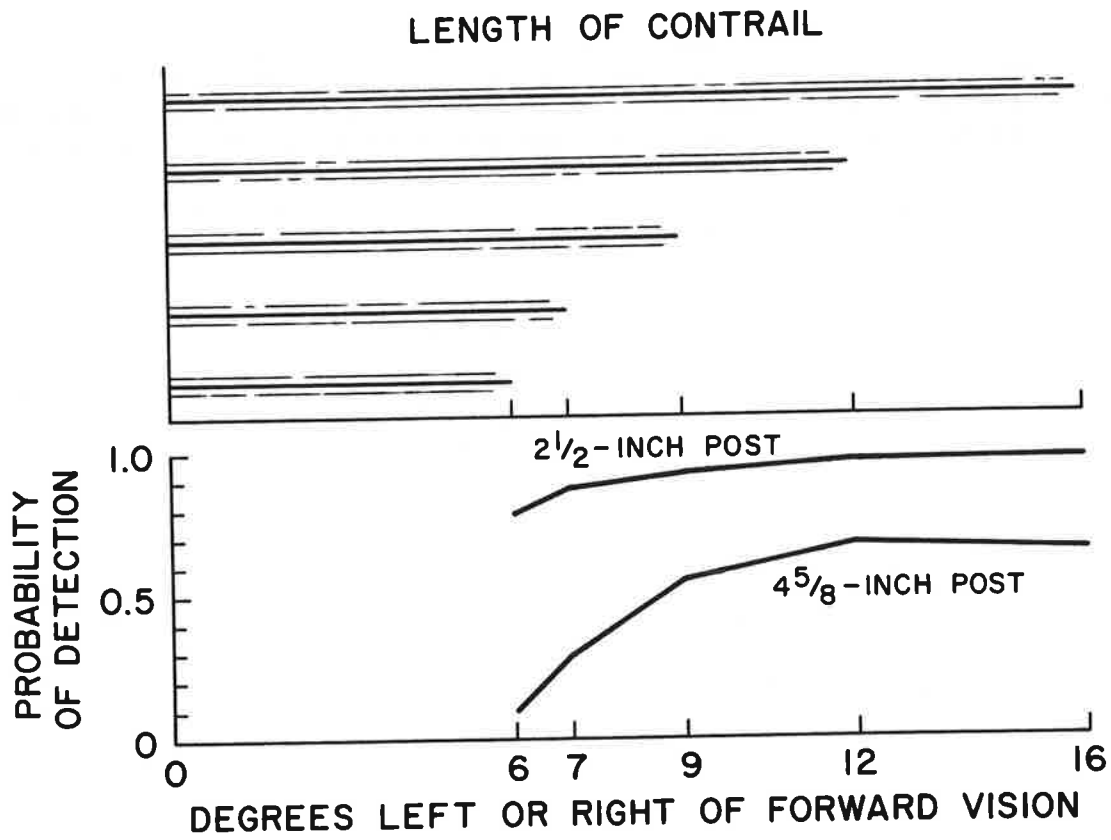

Figure 6. Probability of detecting simulated contrails of varying angular subtense against a uniform background as a function of the obscuration caused by window posts of 2 1/2- and 4 5/8-inch projected widths at 12 inches from the pilot's eyes. (Hull and Roscoe, in preparation)

Several experiments have demonstrated accommodation shifts with interposed mental activities (for example, Malmstrom, 1978; Gawron, 1979; see Figure 7). Bob Randle and John Petitt found that accommodation shifted outward between measurements 20 seconds and 10 seconds before touchdown on simulated landing approaches by reference to a computer-animated night visual scene. We have no comfortable explanation (Randle, Roscoe, and Petitt, 1980).

However, outward accommodation is at least partially mediated by the sympathetic branch of the autonomic nervous system (Cogan, 1937; Benel, 1979; Gawron, 1979). That's the one that makes us run faster and fight harder. It also helps us see the distant enemy in the shadow of a rock and the stag behind a bush. It increases our acuity by magnifying what we see, just as outward focus magnifies the moon. Can it be that the flow of sympathetic adrenalin in the attack pilot expands his visual world, makes the ground appear lower, and causes him to pull up too late? When a periscope's magnification is set too high, pilots are often surprised by a touchdown far short of the runway (recall Figure 1). Randle, Petitt, and this author also found that pilots do not accommodate accurately to changing focus demands induced by ophthalmic lenses. They responded slightly better to a direct view of the computer-animated display than to collimated virtual images as presented on head-up displays, thus bringing into question the supposed advantage of preparing the eyes to see the runway when it suddenly appears on low visibility approaches. Optically collimating an image tends to release our focus from the distant stimulus and allows it to lapse toward the dark focus distance.

### Environmental Variables

This discussion might have been headed, "St. Thomas Revisited." Surely one of the most puzzling and dramatic aviation mysteries surrounds the crash of an American Airlines B-727 at Harry S. Truman Field, St. Thomas, Virgin Islands, in 1976. Captain Arthur Bujnowski had made 154 uneventful landings on the same short, wide runway with similar daylight visibility and light, gusting winds. But on April 27, 1976, Art Bujnowski made a normal "slotted" approach, leveled off a few feet above the runway, and floated beyond the point of no return. The flaming crash and resulting smoke cost the lives of 35 passengers and two flight attendants (NTSB, 1976; Roscoe, 1976, 1980a).

Art Bujnowski is a pilot's pilot, a skillful, calm, no-nonsense ex-Captain, now in forced retirement in Connecticut and permanently grounded. But three minutes before his ill-fated landing in 1976 he was in extreme pain from blocked ears due to an abnormal increase in cockpit and cabin pressure caused by mismanagement of the air compressor during a rapid descent. Other crew members and passengers were in similar pain. Intense stimulation of the inner ears causes an accommodative spasm of the eyes at about arms' length on average (Clark, Randle, and Stewart, 1975).

Neither Bujnowski nor his copilot could see the clearly visible VASI lights on final approach, and both testified they expected the airplane to touch down, as doctrine called for, 1000 feet from the runway threshold. But it did not touch down, and with about 1500 feet of runway remaining, the

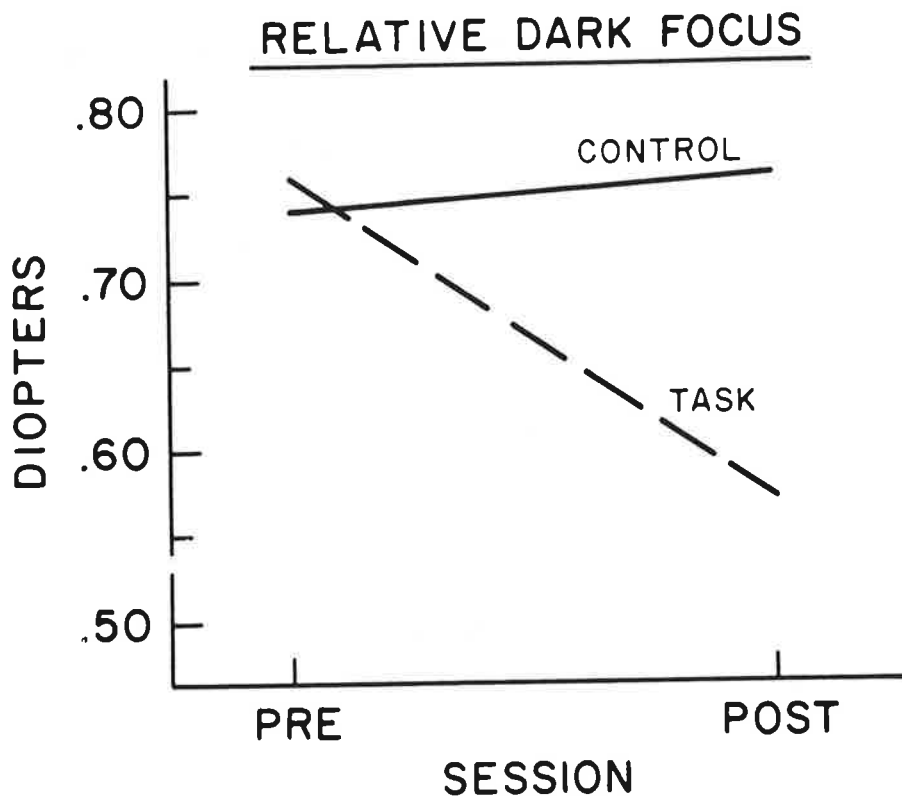

Figure 7. Relative dark focus (absolute dark focus minus far-point focus in diopters) before and after TASK subjects performed a short-term memory task (delayed digit cancelling) for four minutes and CONTROL subjects rested for four minutes.

copilot finally said, "You're still high, Art." The same comment is often made by a safety pilot in the right seat while a pilot-subject rounds out high and floats with a periscope set at x1 magnification. The visual field is compressed with near accommodation, and the runway appears higher than it is. As Art Bujnowski remembered:

"...all I could see were cottages and stores or whatever they were. But it seemed like the activity was right there at eye level, ..."

(Transcript of NTSB public hearing, p. 360.)

#### REAL-WORLD APPLICATION

Randle's demonstration of the possibility of conditioning the accommodation reflex by the application of biofeedback calls for systematic investigation of the trainability of individuals varying in dark focus distances and other oculomotor abilities. Basic data in this area are fragmentary but promising, and effective conditioning techniques are needed involving only simple, inexpensive equipment that can be used by instructors or technicians with limited training, or even by the individual pilot. There has been some success using a simple vernier optometer constructed from crosspolarized strips of inexpensive filter material (Simonelli, 1979).

The effective focal distance of the eyes can be manipulated either voluntarily, following bioconditioning, or involuntarily, by having pilots wear polyfocal glasses as is done by United Air Lines (Harper and Kidera, 1968). Acuity in resolving distant stimuli is enhanced by focusing at a distance greater than that of the stimulus to be discriminated (recall Figure 3). It is possible that detection of distant "point" targets, such as other aircraft, also can be enhanced by inducing accommodation to distances at or "beyond" optical infinity for individuals capable of unusually distant focus.

Each of the so-called anomalous myopias and its associated micropsias\* are encountered in varying degrees by pilots flying airplanes, particularly ones with head-up displays. Similar myopic responses and micropsic perceptions occur in airplane simulators with contact visual systems. Recall that it was concern with the bias errors in landing with imaging flight displays that stimulated interest in this line of research in the first place. It is evident that pilots do learn to compensate partially for such biased perceptions. The possibility of training individuals to recognize conditions in which to expect macropsic\* as well as micropsic misperceptions and to compensate for them voluntarily is out there like Mt. Everest (or Mt. St. Helens).

---

\*Reduced apparent size.

\*\*Increased apparent size.



REFERENCES

- Benel, R.A. Visual accommodation, the Mandelbaum effect, and apparent size. Las Cruces, NM: New Mexico State University, Behavioral Engineering Laboratory, Technical Report BEL-79-1/AFOSR-79-5, 1979.
- \*Benel, R.A. and Benel, D.C.R. Accommodation in untextured stimulus fields. Champaign, IL: University of Illinois at Urbana-Champaign, Department of Psychology, Technical Report Eng Psy-79-1/AFOSR-79-1, 1979.
- Clark, B., Randle, R.J., and Stewart, J.D. Vestibular-Ocular Accommodation Reflex in Man. Aviation, Space, and Environmental Medicine, 1975, 46, 1336-1339.
- Cogan, D.G. Accommodation and the Autonomic Nervous System. Archives of Ophthalmology, 1937, 18, 739-766.
- Gawron, V.J. Eye accommodation, personality, and autonomic balance. Las Cruces, NM: New Mexico State University, Behavioral Engineering Laboratory, Technical Report BEL-79-2/AFOSR-79-6, 1979.
- \*Gawron, V.J. Differences among myopes, emmetropes, and hyperopes. Las Cruces, NM: New Mexico State University, Behavioral Engineering Laboratory, Technical Report BEL-80-1/AFOSR-80-1, 1980.
- Gibson, J.J. The perception of the visual world. Boston: Houghton Mifflin, 1950.
- Harper, C.R. and Kidera, G.J. Flight Deck Vision and the Aging Eye. Aerospace Medicine, 1968, 39, 1119-1122.
- \*Hennessy, R.T. Instrument Myopia. Journal of the Optical Society of America, 1975, 65, 1114-1120.
- Hull, J.C., Gill, R.T., and Roscoe, S.N. Locus of the stimulus to visual accommodation: Where in the world, or where in the eye? Las Cruces, NM: New Mexico State University, Behavioral Engineering Laboratory, Technical Report BEL-79-5/AFOSR-79-9, 1979.
- Iavecchia, H.J., Iavecchia, H.P., and Roscoe, S.N. The moon illusion: Apparent size and visual accommodation distance. Champaign, IL: University of Illinois at Urbana-Champaign, Department of Psychology, Technical Report Eng Psy-78-4/AFOSR-78-3, 1978.
- Kaufman, L. and Rock, I. The Moon Illusion. Scientific American, 1962, 207, 260-268.

- Kraft, C.L. A Psychophysical Contribution to Air Safety: Simulator Studies of Visual Illusions in Night Visual Approaches. In H.A. Pick, Jr. (Ed.), Psychology: From research to practice. New York: Plenum Press, 1978.
- Kraft, C.L., Farrell, R.J., and Boucek, G.P., Jr. Visual performance from the 737 cab as a function of pilot's position within the cab. Seattle: The Boeing Company, Unnumbered internal report, 1970.
- \*Leibowitz, H.W. and Owens, D.A. Anomalous Myopias and the Intermediate Dark Focus of Accommodation. Science, 1975, 189, 646-648. (a)
- \*Leibowitz, H.W. and Owens, D.A. Night Myopia and the Intermediate Dark Focus of Accommodation. Journal of the Optical Society of America, 1975, 65, 1121-1128. (b)
- \*Leibowitz, H.W., Hennessy, R.T., and Owens, D.A. The Intermediate Resting Position of Accommodation and Some Implications for Space Perception. Psychologia, 1975, 18(3), 162-170.
- Luria, S.M. Target Size and Correction for Empty-Field Myopia. Journal of the Optical Society of America, 1980, 70, 1153-1154.
- Malmstrom, F.V. Effects of Concurrent Mental Activity on Static and Dynamic Accommodation Responses. Ph.D. dissertation, Oklahoma State University, 1978. (Dissertation Abstracts International, 1979, 39B, 61-62.)
- National Transportation Safety Board (NTSB). Aircraft accident report: American Airlines, Inc., Boeing 727-95, N1963; St. Thomas, Virgin Islands, April 27, 1976. Washington, DC: United States Government Printing Office, Report NTSB-AAR-77-1, 1976.
- \*Owens, D.A. Factors Influencing Steady-State Accommodation. Ph.D. dissertation, Pennsylvania State University, 1976. (Dissertation Abstracts International, 1977, 37B, 5863.)
- \*Owens, D.A. The Mandelbaum Effect: Evidence for an Accommodative Bias toward Intermediate Viewing Distances. Journal of the Optical Society of America, 1979, 69, 646-652.
- \*Owens, D.A. and Leibowitz, H.W. The Fixation Point as a Stimulus for Accommodation. Vision Research, 1975, 15, 1161-1163.
- \*Owens, D.A. and Leibowitz, H.W. Oculomotor Adjustments in Darkness and the Specific Distance Tendency. Perception and Psychophysics, 1976, 20(1), 2-9. (a)
- \*Owens, D.A. and Leibowitz, H.W. Night Myopia: Cause and a Possible Basis for Amelioration. American Journal of Optometry and Physiological Optics, 1976, 53, 709-717. (b)

- Palmer, E. and Cronn, F.W. Touchdown Performance with a Computer Graphics Night Visual Attachment. Proceedings of the AIAA Visual and Motion Simulation Conference. New York: American Institute of Aeronautics and Astronautics, 1973.
- Randle, R.J. Volitional Control of Visual Accommodation. AGARD Proceedings No. 82 on Adaptation and Acclimatization in Aerospace Medicine. Neuilly-sur-Seine, France: North Atlantic Treaty Organization, 1970.
- Randle, R.J., Roscoe, S.N., and Pettit, J. Effects of accommodation and magnification on aimpoint estimation in a simulated landing task. Washington, DC: National Aeronautics and Space Administration, Technical Paper NASA-TP-1635, 1980.
- Roscoe, S.N. Aircraft Pilot Performance as a Function of the Extent and Magnification of the Visible Horizon. Ph.D. dissertation, University of Illinois at Urbana-Champaign, 1950. (Dissertation Abstracts International, 1951, 11, 173.)
- \*Roscoe, S.N. Ground-Referenced Visual Orientation in Flight Control Tasks: Judgments of Size and Distance. In Vision R&D Program Review. Washington, DC: Naval Air Systems Command and Office of Naval Research, 1975, 145-174. (Originally issued by the University of Illinois as Technical Report ARL-75-7/ONR-75-1, 1975.)
- Roscoe, S.N. Appendix I: Human Factors and Crew Performance in the St. Thomas Accident. In Accident Investigation Post-Hearing Submission to the National Transportation Safety Board, B-727 Accident, St. Thomas, Virgin Islands, April 27, 1976. Arlington, TX: Allied Pilots Association, 1976.
- \*Roscoe, S.N. How big the moon, how fat the eye? Savoy, IL: University of Illinois at Urbana-Champaign, Aviation Research Laboratory, Technical Report ARL-77-9/AFOSR-77-8, 1977.
- Roscoe, S.N. When Day is Done and Shadows Fall, We Miss the Airport Most of All. Human Factors, 1979, 21, 721-731. (a)
- Roscoe, S.N. Ground-referenced visual orientation with imaging displays: Final report. Champaign, IL: University of Illinois at Urbana-Champaign, Department of Psychology, Technical Report Eng Psy-79-4/AFOSR-79-4, 1979. (b)
- Roscoe, S.N. Aviation psychology. Ames, IA: Iowa State University Press, 1980. (a)

- \*Roscoe, S.N. Bigness Is in the Eye of the Beholder. Proceedings of the Seventh Symposium on Psychology in the Department of Defense. Colorado Springs: United States Air Force Academy, 1980, 39-80.  
(b)
- \*Roscoe, S.N. and Benel, D.A. Is the eye smart or the brain forgiving? Champaign, IL: University of Illinois at Urbana-Champaign, Department of Psychology, Technical Report Eng Psy-78-1/AFOSR-78-1, 1978.
- Roscoe, S.N., Hasler, S.G., and Dougherty, D.J. Flight by Periscope: Making Takeoffs and Landings; the Influence of Image Magnification, Practice, and Various Conditions of Flight. Human Factors, 1966, 8, 13-40. (Originally issued in 1952 by the Office of Naval Research as Human Engineering Report 71-16-9, classified CONFIDENTIAL.)
- \*Roscoe, S.N., Olzak, L., and Randle, R.J. Ground-Referenced Visual Orientation with Imaging Displays: Monocular versus Binocular Accommodation and Judgments of Relative Size. Proceedings of the AGARD Aerospace Medical Specialists Meeting, Athens, Greece. Neuilly-sur-Seine, France: North Atlantic Treaty Organization, 1976.
- Simonelli, N.M. The dark focus of visual accommodation: Its existence, its measurement, its effects. Las Cruces, NM: New Mexico State University, Behavioral Engineering Laboratory, Technical Report BEL-79-3/AFOSR-79-7, 1979.
- Simonelli, N.M. Polarized Vernier Optometer. Behavior Research Methods and Instrumentation, 1980, 12, 293-296.
- Simonelli, N.M. and Roscoe, S.N. Apparent size and visual accommodation under day and night conditions. Champaign, IL: University of Illinois, Department of Psychology, Technical Report Eng Psy-79-3/AFOSR-79-3, 1979.

DR. DIEHL: Thank you. Stan, as always, has provided us with a lot of food for thought. Our next speaker is Colonel George C. Mohr. He is currently the Commander of the U.S. Air Force Aerospace Medical Research Laboratory at Wright-Patterson AFB.

Colonel Mohr received his M.D. degree from Harvard in 1957 and his Master of Public Health degree in 1961. He is board-certified in aerospace medicine by the American Board of Preventive Medicine. He is currently a Chief Flight Surgeon. He has been on active duty for over 25 years. Probably of more significance, he has been involved with biotechnological research for the past 17 years.

He has held a variety of positions involving vibration and impact research as well as bioacoustics and has been the Technical Director of the Life Support Division at the Headquarters, Aerospace Medical Division.

He has also been the Director of Research and Development and the Vice Commander of the Aerospace Medical Division. He is the author of over 40 articles. We have asked him to talk in the area of pilot workload and techniques to assess pilot workload in high-performance military aircraft.

COLONEL MOHR: It is a pleasure to be here this afternoon to tell you a little about my laboratory and, in particular, about one of our very important programs supporting military aviation.

First of all, biotechnology in the Air Force is concerned specifically with the design of advanced manned weapons systems. Therefore, it is a highly applied kind of research and quite different from the clinically oriented medical research that is conducted by most health-oriented Federal agencies.

In this respect, it is very closely allied with the work that is done here at CAMI and, of course, the work that is done in our two sister services, the Army and the Navy, and by NASA. The work I manage in my laboratory is concerned with three broad areas. The first of these comes under the heading of biodynamics and bioengineering. There are four major thrusts in this program - the first being the crucial area of communication in noise. Much of the research that was done by the military departments that is realized in our current aircraft was, in fact, completed in the 1950s. Today we are confronted with a need for highly secure, high fidelity communications, both within the aircraft and between the aircraft and the ground. This has led us to develop new digital systems for which overall systems performance has yet to be defined.

We also have major programs concerned with transient accelerations, very important to egress systems design, and programs concerned with sustained and maneuvering acceleration that pose very severe stresses on the pilot operator in our high-performance fighter aircraft.

Fortunately, most of these disciplinary areas can be dealt with in engineering terms by translating the characteristics and materials properties of the body and the physical response of the cardiovascular and nervous systems into analytic models that allow us to translate medical information into hard engineering design points.

The second area of major interest in my laboratory deals with the broad disciplines of human engineering. I will not enter into a debate on exactly how human engineering overlaps with the broader area of human factors.

But let me say that this area is conducted in concert with the work done by our sister laboratory, the Air Force Human Resources Laboratory. If I were to simplify our program, our focus would assume availability of average-skilled and average-trained operators.

It is our job to assess operator vulnerabilities and capabilities and translate these into specific design points for controls, displays, cockpit layouts, and the provision of automated aids for information management.

We work broadly, cutting across all of our military missions. We have major programs related to strategic bomber design. This, of course, will be of considerable interest now with the LRCA (Long Range Combat Aircraft) programs and the possibility of an advanced technology bomber coming to the forefront. We also have major programs concerned with tactical aircraft design. We currently fly very high performance aircraft, and the next generation promises to offer even more sophistication.

Many of our programs that deal with the design of our weapons systems also provide very real insights into the vulnerabilities of our enemies' weapon systems. Many of our programs therefore deal with means to counter the human operator in enemy weapons systems.

The third broad area in my laboratory deals with the specific human hazards associated with chemicals. In recent years, the focus has been on missile propellants, but today as we embark upon the need for alternative and synthetic fuels, much of the work is centering on developing a standard which is not only

consistent with the engine requirements but will also provide a fuel which is safe to handle, manufacture, store, transport, and dispose of.

After those brief comments on the activities of my laboratory, I would like to center your attention on one of the major areas of concern within the biotechnology community.

A research aircraft, AFTI (Advanced Fighter Technology Integration), will be flying within a few months. It is a very sophisticated test bed designed around an F-16 modified with various canards. It is capable of decoupled flight, which will allow this airplane to literally fly sideways. This is possible because of the very rapid advances in on-board computing power available to military aircraft.

As we move into the era of submicron chip electronics, we will soon be able to manage hundreds of data channels essentially in real time. All of this, of course, brings to bear on the human engineer the very difficult problem of sorting out what information must be provided to the operator in what form, in what time frame, and with what update rates.

In other words, there is the whole problem of workload because, indeed, the military pilot must do a great deal more than fly the vehicle, that is, manage the aircraft controls. After all, it is his principal job to safely enter a high threat environment, find and select a specific target of greatest value, strike that target effectively while safely evading, deceiving, avoiding or countering the threats and finally making his way back to the base for recovery.

Therefore, the military pilot has to fly his airplane, manage the threats, find the targets, and manage the weapons; and in doing so, he must share his attention, his eyes, his hands and feet and his brain in a prioritized fashion.

Now, this is the basic rationale for our program. I should point out that the AFAMRL (Air Force Aerospace Medical Research Laboratory) workload program is an effort which is conducted jointly with my sister laboratory, the School of Aerospace Medicine at Brooks AFB.

It is also a triservice program where we have close relationships with the Army and the Navy. Basically, what we are trying to do here, however, is build upon 40 years of research in this area and to capitalize on the literature in order to achieve certain specific goals.

We have to be able to measure objectively, even when we are dealing with subjective factors. We want to standardize workload measures in a matrix so that we can generalize from mission to mission or system to system.

More importantly, we need to apply these workload measures through a standardized battery which can be realized in hardware and be made flightworthy. Of course, that means we must overcome very severe constraints on power, volume, weight, and reliability.

Now, the way we are approaching this is through a task force of scientists representing a broad range of disciplines. I must say, at this point, this work is not mine. It is the work of the scientists in my laboratory. Therefore, I am only presenting the work that they are accomplishing.

We have broken the problem down into three elemental tasks. The first is to derive a standardized procedure to describe the mission, basing the technique on well-known task analytic approaches. The second task is to arrive at a set of rating strategies that will allow us to deal with conceptual missions, missions for aircraft yet to be designed because it is our objective to get well ahead of the designers and mission planners so that we can design out some of the problems that Professor Roscoe has so eloquently described. The third task is to develop objective psychophysiological measures of workload. Our capability, to date, to describe operation missions requires gross simplification of a rather complex problem. We have currently completed an analysis of a classical air-to-ground mission in the A-10. In the immediate future, we will be analyzing air superiority missions with the F-15 as well as looking into the application of the F-16 for night and adverse weather operations at much higher speeds in air-to-ground operations against the enemy.

Basic intent, of course, is to break the given mission down into a set of specific tasks, identifying the kind of information that must be provided, the decisions that must be made, and the actions that must take place and in turn, to break these factors down in terms of their time and performance criticality. In other words, some actions need to be accomplished within very narrowly defined time limits in addition to being performed correctly. Many other things that are done can be set aside for a moment or can, in fact, be performed with less than ideal precision.



Once this kind of analysis is available, a given mission scenario can be defined by a set of carefully described sub-segments which can be evaluated by experts drawn from the operational community, all of whom are well-versed and experienced with that particular mission.

This information then is used in the further development of the specific assessment that I will describe for you in a moment pertaining to the subjective estimates of workload.

The magic bullet for this assessment technique is also based on the work of others, but appears to be offering significant power in allowing us to generalize across different mission scenarios.

The analytic technique we are using is conjoint analysis which allows us to deal with more than a single dimension of subjective workload and, more importantly, to transform ordinal data to an interval data scale. In other words, if A is rated harder than B and B is harder than C, we can convert these ordinal ratings for each combination of dimensions to an interval scale, to finally arrive at a single value which gives us a true numerical weight for each particular combination of conditions judged by a population of raters.

For instance, consider a three-by-four rating system, where you break the mission scenario down into three workload vectors: the time load factor, the mental effort load factor and the psychological stress load factor. These three dimensions are then considered at four different levels of difficulty for each factor which gives you four to the third (64) different combinatory cells in the matrix. Note that time load, mental load, and psychological load, often referred to as pucker, can be applied to a wide range of specific missions and relate to such demands as cognitive management of information, flying precision, observation of displayed information, target characteristics, etc. These are rather generalized descriptors of the types of major workload factors that appear to impact on the overall difficultness of the mission.

Without attempting to explain the detailed mathematics, I could demonstrate how the combinations of these three factors: time stress, psychological load, and mental effort can be rated by a given subject into a matrix of descending difficultness. To illustrate this, the overall mission is rated in relation to the relative influence of psychological or pucker factor, time stress demand and mental effort demand on overall workload.

There is a set of constraints which are applied to determine whether or not the ratings are biased or unbiased. Ratings are obtained from a sample of pilots rank ordering the difficultness of the 64 different cells in the matrix. Through algorithms which basically linearize the contribution of each rating factor to the overall workload characterizing the given mission, we arrive at an interval assessment of how the workload factors interact. Now the important point here is that for a particular mission that is so rated, the relative weight of say, a high level of pucker and a high level of time stress might be shown to predominate in determining overall workload.

For another mission scenario, that particular factor combination, because of the difference in the relative weighting placed on each factor in the scenario, might result in a lower workload rating. This allows one to compare across two different missions the relative weight placed by the pilot operators on the importance of each workload vector in a general sense.

Needless to say, this approach needs to be further evaluated. We have done some very early work where we have applied this approach to an air-to-air missile engagement. We are currently applying it to a strategic bomber mission and also to a refueling mission.

Thus far, these data look very reassuring.

Continuing with the development of the workload measurement battery, we are borrowing again from the literature to develop imbedded secondary task measures based on the Sternberg test technique which has great power. Unfortunately, the Sternberg test itself is obtrusive and requires conscious attention. We have developed ways of implementing such tests in an unobtrusive manner.

One of the most promising methods is our imbedded secondary communications test. Every pilot in military operations expects to receive a good deal of chatter while flying.

For example, an A-10 pilot might typically be instructed to go to UHF Channel 5 and report presence of a SAM to "Dogbone." In order to do that, he has to go through a series of elemental task performances. He will not ordinarily recognize he is performing a short-term memory task, nor will he recognize that he can be measured with respect to his complex reaction time. These measures of complex reaction time for short-term memory can be obtained without the pilot realizing that a secondary task has been imposed while he was flying, say a demanding terrain following air-to-ground, mission segment.

We are also, in developing the measurement battery, relying heavily on the voluminous literature that relates to electrophysiologic measurement techniques. I would like to give you a few insights into one method of great promise: specifically evaluating evoked response potentials derived from the electroencephalogram.

Much of the work in the literature was done with single stimulus transient evoked responses. We, however, have been looking at high-frequency steady state evoked response, particularly visual evoked responses. If you flicker a light above the critical fusion frequency at relatively low intensity levels, the test is unobtrusive. We found indeed that you can obtain very nice evoked responses using a spectrum analyzer. The response is time-locked with a specific phase lag and amplitude ratio measurable for a stimulus frequency range of 40 to 60 Hertz. Observed amplitude changes relate analytically to workload level. There is some variability, of course, between subjects. We also have found one can mix stimulus frequencies in this range, 45, 50, and 55 Hertz. One can simultaneously measure the amplitudes and the phase lag for each stimulus frequency. Interestingly enough, if one plots the phase lag against frequency, the slope of that line in units of seconds turns out to be very closely related to the neurotransmission speed which changes again with stress levels.

Now, what is all this going to do for us? We believe that by investigating the various categories of military operations (and the greatest current interest is in the high-performance air superiority and air-to-ground missions), we can identify critical mission scenarios which can be reliably rated in interval terms using the conjoint analysis technique. We can add this information to a battery of imbedded behavioral tasks and neurophysiologic measurements to arrive at an index of workload which can be used to identify those aspects of system design and operation tactics which have the greatest sensitivity and potential for degrading the effectiveness of the manned system. Hopefully, this will allow us to gain enough insight to design out many of these problems in or next generation aircraft.

More importantly, if we can arrive at objective measures that we can use for specifications and, at the same time, provide an airworthy measurement system that can be used in the test environment by the operator, we will be able to

encourage compliance - in short, give the Government the opportunity to measure how well the designer has done.

That is our program and I hope to see success within this decade.

DR. DIEHL: Colonel Mohr, thank you so much for the insight into the Air Force program. I am sure we will benefit from much of this work in the not-too-distant future.

Our next speaker, Dr. Sulzer, earned his Ph.D. in Psychology from Duke University in 1953. He spent ten years working for the United States Air Force at the Electronic Systems Division. He was at the FAA Technical Center from 1963 until he retired in 1980. There he worked on various types of aeronautical equipment and air traffic control systems. Since that time, Dr. Sulzer has been the consultant to Wright State University and the United States Air Force. We are going to ask Dick if he would give us an overview of the pilot workload study that was undertaken by Wright State University for the FAA and the Air Force.

DR. SULZER: In 1965, the current regulations covering minimum crew determinations became effective. That represented a switch from an aircraft weight criterion to an aircraft design criterion. After 1965, each transport flight deck was studied and evaluated by FAA to determine whether the design crew was adequate to handle the workload in normal and contingency conditions. Hence, it was recognized that an aircraft flight deck might be designed and equipped, so that there were many complex crew duties and emergency procedures requiring a larger number of crew members; or a different aircraft flight deck might be differently designed and equipped, so that there were simpler and fewer crew activities required, and a smaller crew size might be acceptable.

Further, it was not necessarily the case that small transports would have fewer crew responsibilities and larger aircraft more - possibly a large aircraft could be more automated or even less complex by design and might need

less piloting than a smaller transport.

However designed, it was not the FAA who was telling manufacturers how to design flight decks; the freedom to innovate and improve is inherent in the regulation of minimum standards that leave open the opportunity to add additional features and new simplifications or automatic systems at the manufacturer's option. What the new 1965 regulations said was, however designed, FAA will evaluate crew size in terms of crew workload, not mere gross weight of the aircraft.

One further point on crew workload is worth noting. One cannot simply add up all the necessary and possible contingency crew duties and activities and say, for example, this highly automated flight deck scores a "42" and so acceptable for two pilots, while their other more work intensive flight deck scores a "61" and requires three. It is not only the number of indicators and the complexity of actions required but also the configurational properties of the design that are important.

If it were desired, a simple and highly automated set of crew systems could be laid out in a design that restricted access and so subdivided responsibilities that a relatively light workload was spread over a larger crew.

The oft repeated demand that aircraft systems indicators be placed on a panel reachable only by a side-facing flight engineer smacks of this sort of reasoning. With regard to the new Airbus design, pilot associations committed to a minimum flight crew of three actually have published studies that purport to show that an engineer's panel, out of the pilots reach and near vision, is a necessity, regardless of the degree of simplification and automation.

And, of course, the FAA regulations have never ordered a particular arrangement of seating for flight engineers, navigators, or the non-flying crew members. Again, on the concept of minimum standards and maximum freedom to innovate and improve, the FAA has left the flight deck layout conventions as permissive as possible. Now the International Federation of Airline Pilots Associations (IFALPA) would wish to see that freedom reduced so that Airbus and others would have to design around a standard requirement for side-facing engineer's position.

This relative independence of configuration and simple gross workload is well illustrated, though in extreme form, in the U.S.S.R. We do not know

whether all the crew members are fliers, or perhaps some are policemen whose main job is to see that the fliers come home and do not escape the blessings of the worker's paradise, but take for example the latest helicopter.

As shown in Aviation Week in the current issue, Russia's new heavy lift helicopter, which was demonstrated at the Paris Air Show, lifts 15 tons or so. The flight deck is configured for five crew members. It cannot be flown outside the local area by less than four.

By our standards, if recertificated in the U.S., it would have a minimum crew complement of four. Why? Workload requires it. The pilots cannot see the flight engineers system indicated. The navigator is behind and way off to the side away from the pilot, et cetera.

Suppose Sikorsky built an American helicopter with similar heavy-lift potential. I imagine the navigation system would be up front available to the pilots. The system would be simplified and the few remaining controls would be up front. Such a U.S. version would be certificated for two.

Clearly, the difference in workload has little or nothing to do with the flight environment or the inherent stability, trust ratio, or other aerodynamic properties. Rather, it derives from the design: one requires four, one does not.

Workload then is a function of the design. As all of you know, now in 1981 we have an enormous amount of knowledge about workload, and many models of pilot performance concerning vigilance, systems monitoring, information processing, decision making, problem solving, control performance, and the like.

The first, though, that comes to the mind of a reasonable man is -- surely we have enough information -- let us get about the task of putting it together in a way that is both theoretically sound and practically useful.

You probably saw in Aviation Daily for May 20, 1981 that Pacific Southwest Airlines (PSA) and Southwest Airline pilots backed two-man crews in testimony before the Presidential Task Force on Crew Complement. They agreed that two-man crews provide as much safety and sometimes more than three-man crews. But PSA pilots want more pilot input into the aircraft certification. For example, they were dissatisfied with the minimum equipment list.

But, fundamentally, what they, the pilots, want most of all is a good solid workload standard. Ideally, you can think of this desire as a wish for a black box that you can carry around in a suitcase and attach to the crew members and to the aircraft, and from which you can read out "on a meter" instantaneous and average workload readings - such as: now 65%; was 48% averaged over the last one minute, et cetera.

And who would not want that? When we are dealing with physical work, we very nearly have such a measurement system.

Say I want to compare the workload of pedaling a bicycle at twenty miles an hour over a straight and level course versus riding a moped at the same speed over the same course. To do that I could, for example, have the bike rider and the moped rider breathe into a gas analyzer, I could have each of them wired to a heart-rate recorder, and I could put sensors on their large leg muscles. Then, with suitable leads from the vehicle wheels, I could get solid measures of operator workload and vehicle performance.

We know what the measures would show. And we could compare these work measures to maximum for the individual operators, obtained in maximum performance trials and, say, for example, that the average of our panel of bike riders worked at 79% of physical capacity to match a 20-mile speed that required only 32% of capacity for the gasoline powered machine operators.

So now, for pilot work, which is obviously more mental -- it is re-using, perceiving, deciding, controlling, speaking and so forth, not pumping up and down with the large leg muscles. People desire a similar measurement system and procedure for comparing and evaluating results against acceptability standards, such as same percentage of maximum capacity over some period of time in normal and contingency conditions.

What Captain James Fitzgerald actually said to the Presidential Task Force on Crew Complement, as quoted in the Aviation Daily, was "We ask that first a comprehensive method of measuring human workload be developed. This measurement should then be used to establish a reasonable workload that should not be exceeded by the average pilot."

This seemingly reasonable request is simply that a practical method of measuring total workload be established as a standard, and that this method be used to prove that a given aircraft design is or is not acceptable for the average pilot.

As I said, this is approximately the first thought that comes to mind -- the idea has been expressed time and again in recent years. Well, what about it?

"Unfortunately, once you have worked for a while on the problem, you rapidly find that a quantitative measurement of workload is a little bit of utopia. Human operators are beings very difficult to quantify and totally rationalize, et cetera."

Those last two sentences are not me speaking. They are direct quotes from the most recent authoritative book on the subject: Neville Moray's Mental Workload, Its Theory and Measurement, published in 1979, page 418.

In the final summary section of that book, on page 492, the British authority, David Hopkin, is quoted as saying: "There does not seem to be any major set of concepts about mental workload that no one has ever tried to use in order to solve or throw light on an applied problem. Most techniques have been tried ..." and continuing in the same paragraph, Hopkin says, "Unfortunately, no technique approaches general acceptance as a standard measure of mental workload in applied concepts."

So, right off, let's disabuse ourselves of the notion that we can now, or will soon, be able to do for total pilot workload anything similar to what we can do for various kinds of physical workload; that is, establish really valid and highly inter-correlated objective measurements that enable us to quantify the total performance and compare obtained measures with maxima.

So, no magic bullet is likely to be discovered to solve all problems. But, that is not to say that we cannot make useful measurements and comparisons, and arrive at overall judgments of new designs that will be proven correct by the test of time, and actual live service experience.

In fact, the FAA has been making such correct -- and later proven by experience -- judgments on crew complement, using pilot workload as the standard, for at least fifteen years, or since the current regulations were placed in effect.

The present Wright State University study is just one element in a continuing and broad program of research, workshop exchanges of latest technology, and publication of state-of-the-art summaries and recommended programs for future advances in workload technology.



Our particular study -- which I emphasize is only one small part of a much larger area of study being performed in the military, overseas and here in NASA, and particularly in the aircraft companies that actually perform the design work and design evaluations of computing new ideas for workload reduction and qualitative improvement -- is set up in three phases.

Task One was conducted to describe, clarify and catalog approved flight crew member workload determination techniques that have been used in the past. The idea was not to tell future cockpit evaluation teams how to do it, but rather to indicate how earlier certification programs had been tailored to focus on tests of critical or changed features on the particular flight decks and to show how laboratory, engineering, simulation and flight test methods had been employed successfully to guide choices among design alternatives and to furnish data indicating that workload in the final new design was equivalent to or improved over that of already accepted and proven aircraft.

When you have been working under a set of regulations for fifteen years, and appropriate procedures have been developed to assess workload in widely differing designs such as the DC9 and the B747, and the varying aircraft have all proved acceptable in regular line service, it makes good sense to go back and record what you have been doing and how you have done it. The Task report is in press.

Tasks Two and Three are as yet incomplete although much of the data has been collected. The purpose of these later phases of the Wright State study is to catalog and describe newer workload measurement and evaluation techniques.

By and large, these newer procedures have not been used in past commercial aircraft crew complement determinations but have originated in the military, laboratory experimentation, and in non-pilot workload contexts. If the Wright State team is finally successful, the result will be a handbook telling what detailed techniques are now available, more or less off the shelf, for future testing of specific aspects of pilot workload. And in the case of Task Three, what workload measurement techniques appear to have promise of some future application to flight deck problems but are not yet proven to the status of current state-of-the-art.

The Task 1 report runs to many pages and, obviously, it is not possible to describe here all the various mock-ups, simulations, analytical, experimental,

and flight test procedures. The essence of what we learned in examining material provided by Boeing, Douglas, and Lockheed and by the aircraft certification, engineering flight test, and flight operations evaluation organizations in the FAA regional offices can, however, be stated briefly.

Various methods of evaluating workload have been applied at appropriate stages of flight deck development and have served to answer crucial questions about workload. Final evidence of design adequacy is developed in actual flight test, because neither simulation nor analysis, without actual flight operations, can provide total substantiation that workload and crew duties are satisfactory when compared to existing operational aircraft.

The simulation methods employed to date are most useful for demonstrating overall configurational suitability and specific stimulus-response adequacy. Mock-ups are used to test the visibility and conspicuity of indicators, the convenience of reach and accessibility of controls, and the conformance to layout conventions and pilot expectations. More functional simulators are used to measure the complexity and number of required procedures by count, and by timing simulated pilot actions. The ease of operations of controls and utility of warnings are among the questions examined, and in some cases comparisons are made between activities using new design features versus features of an existing, service-proven flight deck design. Despite the great utility of simulation, not all problems can be solved this way; particularly person-to-person interactions in simulation do not duplicate routine flight conditions due to motivational differences -- hence many causes of errors cannot be revealed.

Also, simulation is not sufficient to prove the operational suitability of large changes in cockpit design, such as conversion to electronic flight instruments. Major changes of flight crew interface may require a complete cycle of analyses, simulation, and flight test before sufficient understanding of the integration of the crew is achieved to permit application to commercial air transport aircraft.

Analyses are made using computer models of internal visibility and physical action requirements. More elaborate time and task computations are also made using pilot response data from earlier detailed part-task recordings and procedures requiring tabulations from sample flights in high workload regimes. Comparison data on time to complete actions in the new design, in contrast to

an operational flight deck, are presented to show the balance of workload between crew members and the appropriate distribution of work requirements over busy periods, such as approach and landing.

Flight testing, sometimes of simulated airline operations, is employed to substantiate the adequacy of design and the acceptability of emergency procedures as well as to demonstrate ordinary flight duties which are characteristic of the new design.

There is no simple solution to all the issues raised and no single tell-all method of testing new designs prior to availability for actual flight. However, the task of workload evaluation can be accomplished to satisfy needs during aircraft design and to provide needed numerical data to support pilot subjective ratings of acceptability and favorable comparison. In combination, the various assessment procedures have been successful. Aircraft designed to be flown by different crew complements have been so certificated and have been proved safe and acceptable in actual line service. The correlation between FAA workload determinations in certification procedures and the ultimate criterion of airline experience has been excellent. Still, the many difficult decisions made in designing and approving complex certification programs should be recognized, and efforts should be extended to develop improved test methods as the understanding of human behavior allows.

Since a portion of all successful evaluations currently involves the attitudes and perceptions of flight crew members, there will be a continuing need for subjective assessment. It is essential that these assessments be made by persons who are experienced in conducting procedures in differently designed cockpits and who are accountable for their judgments. Otherwise, strong individual bias may influence pilot opinion. Also, it is noted that individual production aircraft are examined to consider the workload impact of equipment or configuration variations. Finally, each airline is inspected to verify that actual flight operations are satisfactory with the unique combination of pilot qualifications, special airline procedures, flight deck equipment outage allowances, company equipment added, and challenges of the particular operating environment. Hence, the adequacy of the approved crew complement is monitored continuously to ensure that changes after airworthiness type certification do not invalidate the original determination.

In summary, the Wright State team found that workload confirmation is a continuing process from the earliest concept development through the successive design and development stages. Ultimately, confirmation is accomplished in the prototype airplane as it undergoes intensive test and evaluation scrutiny to confirm and demonstrate suitability.

DR. DIEHL: Our next speaker is Mr. William "Joe" Cox. Joe is currently an aviation consultant in Washington, DC and he has had a very interesting aviation career.

He began his military flying experience as a cadet flying SNJ's and ended up as a commander of the C-5A Wing at Dover. He retired in 1979 from the FAA. He is a highly experienced test pilot.

He has worked on various timely programs and has been a consultant at Wright State University on their workload measurement program. But perhaps his most interesting assignment recently was as a consultant to the Presidential Task Force. Joe's presentation is a review of the Crew Complement problem.

MR. COX: Although we have concluded that the procedures FAA followed in certifying the DC-9-80 for operation by a minimum crew of two were proper and represented the state-of-the-art at that time, we recommend that those procedures be improved and strengthened in several respects in preparation for future certifications.

Rapid developments in the field of digital avionics and flight control systems, and the attendant increased complexities of computer software, require that FAA have the breadth and depth of expertise to address these areas properly during aircraft certification. FAA should make appropriate additions to its staff for these purposes. In addition, we recommend that FAA develop new systems on the role of flight crew members, for certifying software, and for monitoring software configuration changes.

At present, the only generally accepted method for evaluating workload is task/time-line analysis based on comparison with previous aircraft designs. This technique, supplemented by improved subjective evaluation methods applied by qualified pilots, will offer the best means for demonstrating compliance with FAA crew complement criteria. We recommend that the FAA incorporate such methods in the tests to be employed for the certification of the B-757 and B-767

aircraft. Studies of crew performance under a variety of conditions may provide additional methods for the assessment of crew complement in the future. Line operations, full-mission simulation using selected line pilots could be used in conducting these studies.

Consultation with qualified line pilots has long proven to be beneficial and is incorporated to varying extents by manufacturers in the aircraft design process. Several aspects of new aircraft certification, such as crew procedures, workload evaluation, and training requirements, would be enhanced by augmenting FAA certification teams with FAA for a specified period. We recommend that FAA consider adopting such a procedure along the lines of the current procedure for using designated engineering representatives (DERs).

FAA should assign high priority to completing and keeping current Chapter 187 of FAA Order 8110.8 to provide formal guidelines for evaluating the effects of weather, ATC, and other system factors.

The minimum equipment list identifies those items that may be inoperative when an aircraft is dispatched on a commercial flight (with appropriate operating restrictions). Recognizing that crew workload could be directly affected by the minimum equipment list, we recommend that the minimum equipment list be prepared and that related tests for examining combinations of failures be conducted during the crew complement certification process as well as during the subsegment process relating to the development of air carriers' operating specifications.

Crew complement, as noted earlier, is only one among many crew-related issues that have a bearing on aviation safety. On the basis of concerns expressed by flight crews and others, as well as our own observations, we consider these issues to be important in the interest of promoting flight safety.

The aircraft separation assurance program should receive FAA's highest priority, and efforts to improve the ATC system should be adequately and promptly funded. We are encouraged by recent FAA announcements regarding plans for the rapid implementation of collision avoidance systems. As the Airline Pilots Association (ALPA) and others have urged, we recommend that FAA examine the possibility of using the ATC Radar Beacon System in the initial implementation of these systems. Positive control of aircraft should be provided in all heavily traveled air space and major terminal areas at the earliest possible time.

Reliever airports and runways should be established in major terminal areas to provide appropriate separation between low-performance aircraft and jet transports.

To further increase the effectiveness of the ATC system, we recommend that FAA require all aircraft using heavily traveled airspace to be equipped with at least Mode C (altitude encoding) transponders.

Some form of vertical guidance, such as Visual Approach Slope Indicators, should be installed on all runways used by air carriers. Airports served by air carriers should also have instrument landing system facilities. Instrument landing system and related ground support facilities should be upgraded to keep pace with advances in aircraft capability such as autoland.

Local noise abatement procedures in some cases require special flight maneuvers that could compromise safety. We recommend that FAA consider ways of standardizing procedures relating to these maneuvers with safety as the primary concern. Consideration should also be given to exempting newer, quieter aircraft from noise abatement procedures that were designed for older aircraft types.

Improvements should be made in the provision of pre-flight weather briefings and timely and accurate in-flight weather information, particularly in terminal areas.

Flight crews of whatever size should be relieved of and insulated from demands and distractions that do not relate to flying the aircraft. Some measures, such as prohibiting non-flight-related cockpit conversations and communications during critical phases of flight, have been proposed. Potential distractions can be further reduced through the increased use of single transponder code assignments and automated communications devices, and through the establishment of direct communications links between the ground and passenger-cabin crews to deal with such matters as the personal needs of passengers. We also recommend further reduction of non-essential contacts between the passenger cabin and the cockpit. Cabin crews should be trained to deal with passenger problems and to operate cabin equipment without the assistance of flight crew members.

Although the incapacitation of a flight crew member is a rare occurrence, the airlines should uniformly establish programs to train crew members to recognize subtle incapacitation of a fellow crew member and to follow appropriate

procedures in the event of such an emergency. We also recommend the further development and use of restraining devices that would prevent an incapacitated crew member from interfering with the flight controls during critical phases of flight.

We are impressed with efforts by air carriers to reduce the number of crew-related accidents by improving training in command, leadership, and cockpit resource management skills and by establishing line-oriented flight training programs. In addition, we recommend that airline pilots serving as second in command also be required to have an FAA airline transport pilot certificate with type ratings for the aircraft on which they serve.

Special attention should be directed to concerns expressed by some pilots over what they consider to be an excessively punitive approach by FAA in enforcing safety regulations. We recommend that ways be sought to instill and strengthen a sense of trust and cooperation between FAA and members of flight crews. In particular, we recommend that NASA's Aviation Safety Reporting System be strongly supported by FAA and NASA, and that serious provisions applicable to the aviation safety reporting system and to protecting aircrews from unwarranted disclosure of conversations recorded on cockpit voice recorders be enforced.

Many of the Federal Aviation Regulations relating to flight crew responsibilities appear to be unnecessarily complex. An effort should be made to simplify and clarify the Federal Aviation Regulations to make them more understandable and easier to use.

Enroute, terminal area, and approach charts are frequently designed in a way that makes them difficult to use. The design and content of these charts should be improved.

The Secretary of Transportation should take steps to expedite the implementation of FAA's Aviation Safety Analysis System Project to strengthen its ability to collect, process, and disseminate safety-related information necessary for decision-making in FAA and the aviation industry generally. The Aviation Safety Analysis System is being designed to be compatible with other accident data systems, including those maintained by the National Transportation Safety Board and the International Civil Aviation Organization. It is essential that this system include worldwide data.

The research conducted by FAA, NASA, and the Department of Defense on the impact of automation on the role of flight crews should be continued and expanded. We also recommend that strong support be given to the development and evaluation of safety-related systems, such as Cockpit Display of Traffic Information and Heads-up Displays, as well as to on-going research on the effects of fatigue, desynchronosis, and length of duty period on flight crew performance.

When I was asked a few days ago to provide a presentation to this workshop regarding my observations on the crew complement issues, it initially gave me some difficulty. It was difficult, for example, to select a topic that was not under review by the President's Task Force on Aircraft Crew Complement.

And, if the results of the Task Force were not released to the public in time for this presentation I would have difficulty in steering clear of the many sensitive topics that have characterized the crew complement debate. However, it appeared to me that there were neutral areas that were not generally considered to be in the domain of the crew complement controversy.

Not many, but enough to attempt a discussion. For that discussion I had chosen the subject, "Beyond the Crew Complement Problem" to review the various system and operational enhancements that appear to be needed regardless of the outcome of the crew complement question. This would have been somewhat risky, but I was willing to attempt such a discussion to encourage communication on the selected topics within the air transportation industry and, in particular, within this workshop.

However, the Task Force's recommendations were made public last Thursday. I have redirected this presentation around this newly released information. I have also revised the title of this presentation to "A Review of the Crew Complement Recommendations."

Before I start this review, I want to make two or three points. I will attempt to keep my discussion of the Task Force recommendations strictly factual. If I provide additional comments on any matters not contained in the Task Force report, I will identify these as ideas or thoughts not included in the report. Whenever I use the word "we," I am using the words of the Task Force's formal report.

On July 2, 1981, the President's Task Force on Aircraft Crew Complement issued its report concluding that operation of the McDonnell Douglas DC-9-80



aircraft by a crew of two is safe, and that adding a third crew member would not be justified in the interest of safety.

Chaired by former FAA Administrator and Air Force Secretary, John L. McLucas, and including Fred J. Drinkwater, III, Chief of Aircraft Operations at NASA's Ames Research Center, and Lt. Gen. Howard W. Leaf, Inspector General of the Air Force, the Task Force which was appointed by President Reagan was asked to review the August 1980 decision of the FAA to certify the DC-9-80 for operation by a minimum crew of two persons. It was also asked to make recommendations concerning the use of two-member crews in the proposed Boeing 757 and 767 and other "new generation" commercial jet aircraft.

In determining that the DC-9-80 is safe for operation by a crew of two members, the Task Force concluded that the procedures FAA followed in reaching its decision were proper and in compliance with the applicable provisions of the Federal Aviation Act of 1958.

Addressing future aircraft, the Task Force concluded that, as designed, the Boeing-757, Boeing-767, and the A-310 being developed by the European consortium, Airbus Industries, potentially can be operated safely by a crew of two, and that the addition of a third crew member would not be justified in the interest of safety.

The Task Force has said that, although it cannot pre-judge the outcome of the certification process as it would be applied to future aircraft, the present certification process, improved and strengthened as recommended by the Task Force, will ensure proper certification of such aircraft as the Boeing-757 and Boeing-767, and proper review of the certification of such foreign-made aircraft as the A-310, from a crew complement standpoint.

The Task Force's recommendations concerning the crew complement process relate to the FAA procedures and staffing for evaluating digital avionics, flight control systems, and computer software; FAA methods for evaluating crew workload; participation of line pilots in the certification process; FAA guidelines for evaluating aviation systems factors; and evaluation of equipment that may be inoperative when an aircraft is dispatched.

With respect to those recommendations, the Task Force has provided the following: Other safety-related recommendations of the Task Force concern improvements in the air traffic control system and aviation operating procedures;

insulation of flight crews from demands and distractions not relating to flying the aircraft; training and qualification of flight crews; enforcement of safety regulations; the clarity and content of regulations and other documents; and safety-related data collection and research.

A final recommendation was made to ... "urge that FAA take special care to guard against any diminution of existing safety standards among air carriers as a result of economic changes within the industry. New entrants must be held to the same high standards that long-established carriers have maintained and established carriers must be encouraged to maintain their high standards regardless of pressure to cut costs in the face of new competition. The experience to date has been excellent, and we are confident that FAA can be counted on to carry out its duty under the law to maintain the highest standard of safe, reliable air transportation in the United States."

When the Task Force first came together, it quickly identified five areas of major concern and formed teams or panels to deal with the issues related to these areas. The subject areas were the safety record of the airlines, the air traffic environment, cockpit systems and technology, human factors, and the certification process. Each team reviewed the voluminous data available to it and conducted its own analysis. Part II of the Task Force report is a review and analysis of those major issues.

In its report, the President's Task Force on Aircraft Crew Complement has provided the following information regarding its approach to the investigation and study of the crew complement issue:

Within the 120 days we have had to complete our review and analysis. We have endeavored to consider every relevant factor, to hear every responsible proponent of every reasonable point of view, and to examine all written material presented -- from handwritten letters sent by individual pilots, flight engineers, and members of the public, to voluminous filings submitted by parties with substantial interests in the outcome of our inquiry.

We assembled teams of independent experts to conduct studies of all facets of the crew complement issue. In doing so, we drew heavily from various government agencies, especially the National Aeronautics and Space Administration and the U.S. Air Force, as well as a few independent research organizations, for the expertise of individuals who had no ax to grind on the issue before us. Each of the teams conducted an intensive review of the existing literature and analyzed

all available relevant data.

We interviewed numerous pilots, airline executives, and representatives of aircraft manufacturers, the principal flight crew associations, and the FAA. We also visited, and examined data provided by, representatives of European aircraft manufacturers, airlines, pilot associations, and aviation ministries.

In addition to the DC-9-80, we specifically considered the B-757, B-767, and Airbus Industrie A-310 aircraft from a crew complement standpoint. We were briefed extensively on these aircraft during visits to the manufacturer's facilities, and we reviewed substantially related documentation. As cockpit observers, we flew in the DC-9-80 and other currently operational aircraft flown by two- and three-member crews. We also examined mock-ups of the cockpits of the B-757, B-767, and A-310 aircraft, and observed and participated in simulator demonstrations of the B-767 cockpit systems.

Finally, we invited public comments and held ten days of public hearings, during which we and the principal members of the Task Force staff had the opportunity to ask questions of those presenting testimony in an effort to understand fully all the issues, data, views, and perceptions involved. The technical investigations, and the public hearings and comments, provided the basis for our conclusions and recommendations.

At the press conference on the second day of this month Dr. McLucas pointed out that there has been an increase in the fraction of jet transports flown by two-member crews and as this fraction has increased, safety records have improved overall. Furthermore, in 1980, two-member airplanes accounted for twenty-four percent of the scheduled airline fleet and forty-two percent of departures. For that year there was not one fatal accident in the more than four million certified route air carrier passenger operations in the United States.

Dr. McLucas concluded the press conference on March 2nd with the following statement: "We have reached a number of conclusions in the course of our work, but one conclusion stands out. Jet transports can be designed to operate safely with crews of two. They can be designed to operate safely with crews of three. Both designs have achieved excellent safety records."

Thank you.

DR. DIEHL: Thank you very much, Joe. Our next speaker is Capt. Charles "Bill" Connor.

In addition to being a line pilot for a Delta in a 727, he is also an Adjunct Professor of Aviation Psychology at Embry-Riddle University. He holds a Master of Science in Aviation Technology, among other degrees, from Embry-Riddle University. He is a former U.S. Marine Corps pilot. He has been a test pilot, and has flown the L-1011 and the DC-10 aircraft.

I would like to get Bill to give us some prospectives from the operational airline pilot's view point on the Presidential Task Force findings; and, anything else he might provide us within our human factors program.

MR. CONNOR: Thank you. I would like to start with my disclaimer. I am not representing Delta or ALPA, but I would like to cover some of these issues.

The computer/mechanical technology has made a quantum leap in the past decade. But what about human technology, this being the psychological technology and physiological technology. The other area, environmental technologies, make's up this group which has not kept pace with the computer/mechanical technologies.

Let me pose some operational questions. Does the new technology fit the external variable environment? Will the new machines be an extension of the man, or will the man be made an extension of the machine? Will the control be returned to the cockpit? Can the environment be upgraded to maximize automation potentialities? Should artificial intelligence be developed at this time?

Airport facilities -- should all runways have ILS's (instrument landing systems) installed? Should the glide slopes have DME (distance measuring equipment) readouts? Should all runways be grooved and have VASI's installed? Should all runways be standardized with respect to lighting in the following areas: (a) ALSF II lighting; (b) approach light system; (c) sequence flashing lights; and (d) REILS?

What will be the navigation environment? Will we have access to TRSB/MLS, NAV Star, or 4D NAV.? Is there a time frame for implementation of these navigation systems? Can we have electronic vertical guidance in the interim at all runways? Yes.

The end-fire antennae has been available for the past three years. The system has no terrain restrictions or tidal effect. This system is presently installed at Rock Springs, Wyoming.

Should we standardize cockpit information instrumentation with respect to electronic displays? How will we upgrade the existing fleets that do not have the electronic displays? Could the new information formats be a location problem or a search problem?

Will all new aircraft have ground speed readout on the ASI? Will all new aircraft have wind direction and velocity on the HSI's as currently planned?

Would it be more desirable to have wind direction and velocity in numerics on the ASI? I think so. There is a capability in existence to have wind telemetry in the landing zone which is superimposed on the localizer signal presently.

What are the physiological technology factors in this new system? Dehydration -- will the new aircraft have five percent humidifiers? Will studies be done on biological circadian rhythm desynchronization? Will studies be done on noise level fatigue as applied to infrasonics?

Are we studying visual fatigue from high altitude glare or electronic display glare? Are we doing any studies on nutrition as related to crew performance? Are there any studies underway addressing the problems associated with physiological inactivity during long periods aloft?

How will the area of psychological technology be addressed in training? Is LOFT the answer to future training problems in automation? Will we be facing the possibility of mental and perceptual-motor atrophy with the new flight deck automation? Should we consider using climb and descent corridors to eliminate excessive voice communications?

Hopefully some of these questions can be answered during the workshop tomorrow.

Thank you.

DR. DIEHL: In the first session, we heard a great deal about accident investigation and pilot performance. And this last group of speakers will be addressing problems on air traffic controller performance and cabin safety, and we are again fortunate in having some nationally recognized experts on these topics.

Dr. Saul Sells will be our first speaker. He is currently the director of the Institute of Behavioral Research at Texas Christian University and he has been at TCU since 1962.

He is a Professor of Psychology and holds a PhD from Columbia University. He has also taught at the University of Texas and Trinity University. He was, in addition, the head of the Medical Psychology Department at the U.S. Air Force School of Aviation Medicine. He is currently a consultant to several airlines and to a large variety of government and industrial concerns.

He is an editor of various psychology publications and also has been active in the statistical research. He has published over 20 books and approximately 300 journal articles and technical reports.

I would like to point out that he has received quite a number of honors over the years. He has been president of the Society for Multivariate Experimental Psychology, the Southwestern Psychological Association, and the APA's Division of Military Psychology. He has received awards from the Aerospace Medical Association, and holds the Air Force Commendations for Meritorious Civilian Service. He is listed in the Who's Who in the U.S. and the World and American Men of Science. We are delighted to have Dr. Sells here today. He will be talking about air traffic controller specialists selection. Dr. Sells.

DR. SELLS: Thank you.

The United States is probably the only country in the world in which actuarial selection of personnel for employment is a well-accepted practice. This involves the use of previously validated predictors (tests and other types of information, such as demographic and biographic variables) to make probabilistic predictions of success on specifically defined jobs, based on experimental validation studies. Probabilities of success in such situations apply to batches (groups, samples) of applicants and are not specific to individuals, as in clinical assessment, for which validation is not possible because of the uniqueness of each clinical decision.

The usual approach in the design of selection research is first to complete a job analysis in order to identify the critical person characteristics required for effective performance of the job. A competent job analysis is thus useful for the development of a set of predictor instruments and also for evaluation of existing performance measures or, as is usually the case, development of new performance measures appropriate for the research. Unfortunately, performance measures developed for personnel decisions, when professional measurement

principles are not followed, are generally both too unreliable and too vague to be useful as criteria in rigorous selection research.

In a selection study, the experimental selection instruments are administered to a sample of applicants for the job (in a predictive design) or to a sample of incumbents (in a concurrent validation design), and the investigator must obtain performance measures for a suitable period on those hired (in the former case) or on all tested (in the latter case) and then correlate predictors with criteria.

Acceptance of predictors that correlate highly and significantly with the criteria enables the development of composite scores that can be examined in expectancy tables to observe probabilities of success at different levels of predictor score. With reasonably high correlations it is generally found that probability of success increases with higher scores, but at the same time the proportions of applicants qualified at those levels fall off. Determination of a cutting score is a responsibility of management (not the selection research professional) and involves a decision that balances the limited supply of high level talent available against the need for numbers of positions to be filled. The higher the cutting score, the fewer qualified persons available, but the lower the rate of failure to be expected, and vice versa, the lower the cutting score, the greater the number of qualified persons available (qualified as defined by the cutting score), but the higher the rate of failure to be expected.

In actual practice, it is necessary to assure stability of results and this usually involves replication of the research on additional test samples to cross-validate the initial findings. It is frequently possible to consider expectancy for different combinations of predictors. However, a major problem is the inclusion in the research of criterion measures representing different stages of development in a job. For example, in ATCS research, it is possible to utilize laboratory grades and pass vs. fail in training at the FAA academy as criterion (performance) measures at an early point in ATCS career development and also on-the-job performance at later stages, during developmental training and later during full performance level, journeyman performance. In most fields, the relation between performance during training and later progress and performance should not be assumed or taken for granted and is really an empirical question.

Finally, it is accepted doctrine among professionals in selection research that quality control is a continuing necessity when an experimental selection instrument (test battery) is operationalized and utilized over time. Changes in social conditions, in the self-selection of the portion of the population comprising the applicant samples, as well as changes in procedures, may result in changes in yield. Furthermore, changes in the job may alter the results obtained. Once a test battery is accepted for operational use, it should be monitored by essentially cross validation procedures on a continuous basis to provide assurance of its continued usefulness.

The tremendous growth and expansion of commercial aviation in the United States and indeed, the entire world, over the past thirty-odd years have required development of an extensive air traffic control system to ensure aviation safety as well as orderly and efficient use of airports and air lanes by the every-increasing fleets of passenger, cargo, and military aircraft. In this system, operated by the Federal Aviation Administration (FAA), the position of Air Traffic Control Specialist (ATCS) has been and for a considerable time to come, will continue to be the most critical link. Development of technology for a fully automated system is believed by some experts to be a feasible possibility, but in the remote future, the system must depend on the performance of controllers until such equipment is developed, tested, and fully available on an operational basis.

The air traffic controller job is unique in that it has no counterpart in the civilian work force and the numbers of men and women required annually by the Federal Aviation Administration to maintain budgeted staffing levels far exceed those of available personnel trained in the military services, the only present source of trained controller personnel. As a result, the system depends on the recruitment, selection, and training of talented but inexperienced persons from the general labor force.

Research on the selection of air traffic controllers began in the early 1950's, under both military and civilian (FAA) auspices. Beginning in 1960, a series of selection studies was carried out at the FAA Civil Aeromedical Institute (CAMI) that led to the adoption of an operational ATCS selection battery by the then Civil Service Commission (CSC) in 1964. This battery has been employed by the CSC and its successor, the Office of Personnel Management (OPM) for the selection of ATCS's up to the present time. Based on functions identi-



fied in commercially published tests, it consisted of five mainly trait-oriented aptitude tests which correlated significantly with course grades and pass-fail in the FAA Academy. These were: Spatial Patterns, Computations, Abstract Reasoning and Letter Sequence, Oral Directions, and Air Traffic Control Problems.

Between 1964 and the present, only a few changes were made in the procedures based on this battery. These included: (1) In 1968, the CSC battery was waived for applicants with specialized military ATC experience, such as radar control; this was a move to adapt to a serious shortage of ATCS's in a rapidly expanding system. (2) In 1973, an age limit of 30 years was adopted for applicants, based on research which had indicated a negative correlation between age and ATCS performance. (3) Also in 1973, all applicants were again required to take the CSC test, but variable credit was awarded for prior aviation-related experience. In addition, a pre-developmental program, through Executive Order 11813, 1974, provided for noncompetitive hiring of women and minorities in air traffic and other FAA occupations.

Dissatisfaction with the CSC battery arose when serious attrition rates, between 25 percent and 40 percent, were experienced among initially qualified ATCS's during the two to five years that they were training on-the-job to attain full performance level. Although the FAA attempted to cope with this problem by re-establishing a centralized, 15-week ATC Initial Qualification Training Program at the FAA Academy, beginning in 1976, it was felt that great savings would be achieved through an improved selection instrument. In addition, questions were raised concerning the adequacy of the method of granting experience credit and also the extent to which the CSC battery complied with the Uniform Guidelines established by the Equal Employment Opportunity Commission (EEOC).

As a result, continuing research emphasized the improvement of initial selection of ATC applicants, with studies focused on prediction of full performance level in the ATC specialty, differential placement of new ATC specialists in center, terminal, and flight service station assignments, incorporation of measures of prior aviation experience in selection and placement, development of improved performance measures for criteria in selection research, and conformity with EEO guidelines, as well as other related topics.

A significant aspect of new test development has been the emphasis on job simulation tests, as opposed to factor-trait oriented tests, which have dominated the field of pre-employment testing since the emergence of factor analysis as a central theme of psychometric practice, beginning in World War II. Theoretically, test batteries representing relevant factors in the cognitive and noncognitive areas, should with appropriate weighting, provide optimal prediction of performance of any job and also maintain predictive validity when jobs change, merely by alteration of test weights. In actual practice, however, where time constraints on testing prevent saturated representation of the factors, which are heterogeneous for the most part, and where criterion performance measurement is generally reduced to rather unreliable ratings, the requirements of the theoretical models are seldom met. Under these circumstances, well-designed job simulation items that capture the critical essence of jobs to be performed might well produce validity coefficients substantially higher than those achieved by specific trait tests. Indeed, a combination of exceptional skills in test design and criterion performance measurement in the FAA selection research program has resulted in a virtual tour-de-force in the quality of the latest tests for ATCS selection.

Since 1976, four major studies have been carried out with a new test battery consisting of the Multiplex Controller Aptitude Test, a new paper and pencil test that simulates the controller decisions using a radar scope, the Abstract Reasoning and Arithmetic Reasoning Tests from the CSC Battery, and the Occupational Knowledge Test, used to calculate prior aviation credit. These involved large samples representing four important population groups: 1) full performance level ATC specialists (journeymen); 2) developmental ATC specialists with several years of ATC training, but not yet FPL qualified; 3) new ATC appointees, just entering training, and applicants for ATC work.

This research has demonstrated that the new test battery has high validity and is well suited for identifying applicants for the ATCS occupation with the highest potential for success, virtually without reference to sex, race-ethnic group, education, or prior experience. The inclusion of the Occupational Knowledge Test has enabled a superior method of providing credit for prior relevant experience than the previously used Rating Guide. The new battery is not only a major achievement with respect to validity, but also meets the EEOC Guidelines for Employee Selection by demonstrating fairness where there is

adverse impact on women and some minorities, particularly blacks.

Notwithstanding the importance of the achievement represented by this outstanding research, which will result in cost savings of many millions of dollars in attrition, replacement of losses, and training of replacements; there is little doubt that further research and development on ATCS selection will be justified. Hopefully, those responsible for such further work will have the talent and creativity of Dailey and his associates in the MCAT project.

Future R and D in ATCS selection should involve both predictors and criterion measures. In the predictor area it may be mentioned that several critical factors mentioned in job analysis studies have not yet been addressed. These include auditory perception and verbal comprehension, as in receiving auditory messages and oral communication, particularly verbal fluency and speech intelligibility. In addition, despite the elegance with which the essence of the original motion picture displays the Controller Decision Evaluation (CODE) test, developed by Buckley and Beebe in 1970, at NAFEC, was represented in paper and pencil form in the MCAT, the move from machine-implemented, real time situations to static paper and pencil test situations was, in my opinion, a move in the wrong direction.

The CODE test provided excellent simulation of the controller decision tasks with regard to collision avoidance, but also simulated the distribution of controller work-load over time too well to be maximally useful in a test situation. It would have been more appealing if the traffic density had been kept high throughout the duration of the test. Development of the MCAT took the direction of first translating crucial decision problems into a serial slide presentation and then to paper-and-pencil presentation. The final version, which is speeded and spirals toward increasing difficulty of problems presented, is an excellent test. It requires short-term memory, mental computational skills, and attention to diverse information in a speeded, and hence highly demanding situation, while at the same time requiring no prior instruction or training or examinees to perform the tasks.

Considering the fact that Dailey and Pickrel were faced with prohibition against projectors and other equipment for testing by the Civil Service Commission, the exceptional paper and pencil test that they developed can only be admired. Nevertheless, I am convinced that in the 1980's and beyond, no equip-

ment should be too expensive for the air traffic control system. We already have the technology to move our tests to new modes, involving two-way communication with computers, with realistic simulation of even the most complex situations. At this particular time, we may have to wait for support to utilize such equipment in new test development activities. However, I have no doubt that the future lies in that direction. And the future is now.

In the criterion area, what is needed most is new on-line measures of controller performance in his/her complex work environment. I am impressed with the new Radar Training Facility at this Center, which was described by Dr. Boone at a symposium in San Diego in 1979. This will undoubtedly be a research as well as training facility and hopefully will provide a basis for the development of such on-line proficiency measurement, in a manner that will not interfere with ongoing activities. There is also activity at a research level that may result in changes in the system, such as cockpit displays of air traffic information for collision avoidance and distributed management of traffic between air and ground, new computers and computer aids for the controller, and new methods of communication. As these develop and eventually impact the system, it will be necessary to review the functions of the controller and the demand for changes in predictors and performance measures.

At this time the public is aware of many problems in the air traffic control system. However, there has been no implication that I am aware of concerning the quality of the controllers that staff the system. Those that are presently employed were selected mostly by the CSC battery. I have no doubt that when the new battery is adopted the proportion of top quality talent entering the system will be even better.

DR. DIEHL: Thank you very much, Dr. Sells. I appreciated that interesting overview. Our next speaker is Dr. Joseph Tucker. Joe, like all of our other speakers, has a very interesting background.

His operational experience began as a U.S. Army Air Force navigator and later as a navigator instructor. He earned his Ph.D. in educational psychology from Columbia University in 1949. From 1949 to 1957, he was with the United States Air Force Personnel and Training Research Center and from 1957 to 1959, he was with the Space Technology Laboratory where they undertook some pioneering studies in support of the Atlas ICBM Program.

Since 1959 Joe has been involved in a variety of industrial and organizational consulting activities, primarily in the areas of program instruction and educational technology.

And since 1975, he has been the coordinator for the Center for Educational Technology at Catholic University of America. He will speak on aging, stress and performance assessment in the air traffic controller performance.

DR. TUCKER: As we know, the Federal Aviation Administration is the primary employer of Air Traffic Controllers and has management responsibility over all aspects of that employment including selection, orientation, training, retention, progression and retirement. It includes responsibility for assuring, and evaluating periodically the continuing "readiness to perform" of each air traffic controller. That responsibility is operationally met through selected "missions" of the FAA such as the Office of Aviation Medicine and Civil Aeromedical Institute. This paper reports on three concerns that relate to job performance -- aging, stress, and job performance assessment.

### Aging

The facts about air traffic controller aging and retirement present a varied picture. The information presented here is from an Air Traffic Controller Loss Study prepared August 1980, by FAA Headquarters. A well-documented fact is that controllers' careers are longer than other Federal careers. The length of a controller's career is related to the retirement option selected. Over the decade of the 70's, the average controller selecting an optional retirement worked to age 60, about two years longer than the average of other FAA employees and two years less than the average U.S. Government employee. Disability retirees averaged about 23 years of service, and had an average age of about 47 years. Those controllers selecting an "early out" option averaged about 28 years of service. Up to 1975 most retirees selected the voluntary option. Between 1975 and 1981 the disability option was selected most frequently. The current trend is such that it is projected that by 1985, the optional retirement choice will be most often selected followed by ATC "Early Out" and disability in that order. But the fact remains that the Air Traffic Controller career within FAA is one in which controllers evidence strong staying power both as to average retirement age and length of service. These data have been stable for ten years. In fact, average length of service has increased one full

year since 1971. These data show that air traffic controllers enter service at an age younger than most Federal employees and a very large percentage make it a working life career.

Age of entry into service has been shown to have a strong inverse relationship to successful performance in training and subsequently on the job. Research by CAMI in the 60's documented that the attrition among new selectees who were in their thirties or older was so high that FAA management limited selection for the enroute and terminal options to applicants under age 31. This implies that air traffic controlling is a young person's occupation. Research by Cobb in the mid- and late 1960's supported the entry age cut-off by demonstrating that the job proficiency of full performance level ATCS's or journeyman-level controllers, generally tended to decline progressively after age 40. Evidence that this decline, based on job performance ratings, had a significant detrimental effect on system performance is not available. There is medical evidence of physiological changes with age as is to be expected. Yet Booze concluded after studying the morbidity experience of over 28,000 air traffic controllers over a ten-year period, "that experience does not appear excessive when compared with the experience of other outside groups studied, except for psychoneurotic disorders. Additionally, a lack of association between disease occurrence and occupation is observed in the data correlating disease occurrence with length of service and age."

Pickrel and Associates in conducting validity studies to support the use of a Pass/Fail criterion at the FAA Academy documented that air traffic controller performance improved for the first several years on the job. Decrements associated with continuing service occurred primarily among controllers assigned to administrative duties. Aging, per se, was not a factor.

Thackray's study of the effect of age on the ability to sustain attention during performance on a simulated radar task showed that mean target detection time, errors of omission and commission increased significantly with age, with performance impairment occurring earlier in the two-hour experimental session with increasing age. Physiological measures of visual scanning activity and skin conductance level, as well as subjective measures of fatigue, boredom, and attentiveness all failed to provide adequate explanations for the greater decline in performance with age.

Thackray's work, some medical findings and evidence of performance decrements suggests that research into the effect of aging must continue but it must get closer to the actual career experience of the air traffic controller. As Pickrel has pointed out, there is much diversity of activity among the three air traffic control options. There are seven Flight Service Station positions and three levels of facilities. The terminal positions include radar control, VFR and movement of traffic on the ground. The Air Traffic Control Centers similarly have a variety of positions. In addition, workloads vary from facility to facility and from shift to shift. Are the aging controllers being used selectively in a manner significantly different from the younger controllers? In other words, if there is an implicit recognition of performance decrement with increasing age among air traffic controllers, is it being managed within the system in some manner?

In addition to the on-going research being conducted by CAMI and other FAA agencies on the aging process, several other approaches to research may be in order. The Personnel Management Information System should be evaluated as to how well it is tracking key career decisions by controllers and improved where necessary. Longitudinal studies are likely to be more informative than the cross-sectional studies so often used in the on-going research. And, finally, this speaker recommends strongly that consideration be given to use of modern, sophisticated naturalistic inquiry methodology aimed at finding out what really does happen career-wise among controllers as they build up lengthy periods of service. The inconclusiveness of the research on aging at this point suggests that we might not yet have identified the right questions to ask. Naturalistic Inquiry Methodology could lead to the identification of the "right questions."

### Stress

Since the experience of stress is subjective and personal, it is very difficult to state a concise, objective operational definition of the concept. The experience "stress," has physiological, emotional and intellectual correlates all of which help scope the concept. The word "stress" has many meanings in the English language. The following meaning "emotional or intellectual strain or tension" is meaning six in Funk and Wagnalls. Within the context of that definition, strain is "overexertion" and tension is mental strain or intense nervous anxiety.

The job of air traffic controller is one that requires cognitive facility and emotional stability. It is an active, participative job rather than a passive one. However, it is not a physically demanding job. The work itself does not lead to physical overexertion and physical fatigue. Consequently, when terms that have physiological "overtones" such as fatigue and stress are used for the air traffic controller job it is assumed that they have an emotional origin. It is less often recognized that they may have, also, an intellectual, cognitive origin.

The workload of an air traffic controller can vary during a shift, or as a function of location, from low activity to high activity. Emotional stress can be associated with all levels of job activity and the question of what level of activity in air traffic controlling correlates with the minimum of emotional stress is an important human factors question.

Stress of an intellectual, cognitive origin can arise from an information processing overload. The following will discuss stress as information processing overload and then as anxiety.

#### Information Processing

Finkelman and Kirschners' article "An Information Processing Interpretation of Air Traffic Control Stress" in a recent issue of The Human Factors Journal defines stress in information processing terms. They assume that the controlling task places unusually high information processing demands upon controllers for extended periods of time so that they must work close to the limits of their channel capacity. The summary of their article includes the following interesting statement, "The effort required to process information, maintain continuous concentration, and render timely and reasonable decisions is likely to be very stressful. Although stress related performance decrements would not be acceptable in the typical air traffic control situation, the effects of stress may manifest themselves in social and family relationships and in physical and mental health. It is possible that laboratory measures of information processing (such as the delayed digit recall subsidiary task) could be used to evaluate reserve capacity and thereby predict the ability to cope with stress. Air traffic controllers with higher channel capacities may be less likely to make errors under conditions of stress and less likely to suffer the physiological consequences associated with high information processing loads."



"Channel Capacity," an obvious analogy, is the key concept. The trained air traffic controller is assumed to have an ability to process air traffic that is relatively stable in each controller, but varies as to capacity from controller to controller.

Each is assumed to have a "reserve capacity" that can supplement the normal capacity. This capacity also can vary from controller to controller. Under conditions of heavy workload, the controller with a relatively low normal capacity would have to call upon his reserve capacity sooner than a controller with a high normal capacity. The low capacity performer would be likely to experience stress sooner and experience it longer and possibly be more potentially prone to a performance error than the high capacity performer.

This conception is researchable. The implications for selection, training and performance assessment are obvious. Laboratory studies by Thackray at CAMI support the existence of an information overload phenomenon. Research into possible selection instruments such as the "delayed digit recall subsidiary task," seem justified, particularly, at a time when increases in air traffic controller workload are forecast. Since this theory is helpful in explaining the relationship between stress and job performance, I hope there can be a brief discussion of it at tomorrow's workshop.

In summary, stress can both affect one's job performance and be affected by job demands. A plausible conceptual relationship to "channel capacity" can be postulated and tested.

The relationship between stress and other variables may be non-linear and require careful plotting.

### Anxiety

Anxiety has been defined psychiatrically as "a tense emotional state characterized by fear and apprehension regarding the future."

Smith has reported on a decade of research concerning stress, anxiety, and the Air Traffic Control Specialty. Smith's ten studies included attitude surveys, the State Trait Anxiety Inventory, other anxiety inventories and physiological measures. Smith found air traffic controllers, in general, to score low on trait anxiety. There is no reason to assume that trait anxiety, as a personal characteristic of air traffic controllers acts to degrade "channel capacity," with a possible effect on job performance.

State anxiety is sensitive to shift length and workloads. State anxiety scores are higher toward the end of the shift, a condition true of many professions. They tend to be higher on night shifts as opposed to day shifts. However, state anxiety does not show in air traffic controllers a level that would affect either job performance or "channel capacity."

Smith concludes his report as follows "...there is little evidence to support the notion that ATCSs are engaged in an unusually stressful occupation. That is not to say that ATCSs never encountered unusual stress on the job; however, it does appear that this is the exception rather than the rule. ATCSs appear both well-qualified and well-suited for air traffic work. The demands of air traffic work do not appear to place unusual stress on ATCSs; this professional group appears quite capable of handling requirements of the job without distress. The notion that this occupational group is being pressed to the psychological and physiological limit is clearly unjustified."

A study conducted by the University of Michigan Institute of Social Research in 1975 compared stress factors in 23 different occupations. Though largely subjective and based on only about 100 men per occupation, their report would appear to support the position that air traffic control is not necessarily the most or even a uniquely stressful occupation. The study states that in regard to the demand for mental concentration on the job, train dispatchers and family physicians were rated with ATCSs at the highest levels.

Much depends on the criteria chosen for stress. In fact, the report asserts that "if one were to peek at the most stressed occupational groups, they would tend to be the machine paced assembly line workers," an effect of boredom, dissatisfaction with the workload and dissatisfaction with the job as a whole.

This brings us to topics of boredom and monotony and air traffic controlling, for there is anxiety among human factors specialists that increased automation may produce such an effect for air traffic controllers. Thackray has studied this matter recently at CAMI. I conclude this discussion of stress with Thackray's conclusion, "It is concluded that the available data offer no support for the belief that boredom, monotony, or under-stimulation per se produce the syndrome of stress. However, monotony coupled with a need to maintain high levels of alertness, which might exist if controllers lacked sufficient confidence in an automated system, could represent a combination capable of eliciting considerable stress."

## Performance Assessment

My third easy topic is Performance Assessment. Fortunately my time is short. Job performance is the basis for controller retention and progression. Job knowledge is critical but does not appear to be the basis for distinguishing between good and poor performance.

Controllers evaluate each other. In training, the evaluations are based on laboratory exercises, instructor ratings and skills tests. When proficiency is reached, supervisors' ratings are the primary indicator of acceptable performance.

Elimination rates of the FAA Academy vary from 20 to 40 percent. Subsequently, in the field, the elimination rates can reach 20 percent. However, elimination percentages aside, the fact is that controllers believe that they can distinguish between good and poor performers, and do so using the job or job related data in making pass/fail decisions. The impressive predictive validities reported by Dr. Sells testify, in part, to the reliability and validity of the proficiency assessment measures.

But, the search for and research into valid job performance measures continues. One aggregate criterion used in validity studies by Colman consists of measures of training performance, job performance, progression and attrition. Buckley and Associates reported in 1978 on a theory of an approach to objective measurement of the radar control performance of air traffic controllers, by means of air traffic control simulation exercises. Buckley identified at least 45 systems measures of job performance. Currently, Boone is continuing the research into identifying valid, useable measures of job performance and their best combination.

Pickrel has used performance measures to establish pass/fail cut-offs for academy training and has urged the use of Controller Skills Tests to support the reliability and validity of laboratory scores. Currently, the speaker is investigating the feasibility of using micro-simulations for skills testing.

Over the shoulder evaluations by job supervisors have been made more objective based on detailed job/task analyses performed by the System Development Corporation.

The current research and development work promises to provide increasing

objective, reliable and valid measures of ATC job performance. However, their primary use will be for making pass/fail decisions at critical career progression points. The separating of good from poor performances is likely to be improved. However, the determination of what constitutes "mastery" among air traffic controllers and the differentiation of the best controllers from the acceptable ones, awaits a theory of cognitive behavior that is descriptive of what the cognitive repertoire of a controller is and how it is used in the control of air traffic. Kinney and Associates of the Mitre Corporation have made an impressive beginning in this regard as described in their 1977 studies. The writer hopes that this topic can be addressed at tomorrow's workshop concerning the Air Traffic Control Specialists.

DR. DIEHL: Thank you, Dr. Tucker. Our last speaker is Miss Kay Avery. Kay has two degrees, one in education and one in zoology. She taught high school for two years in Wisconsin, and then joined American Airlines where she flew for several years as a line flight attendant. She has held supervisory positions in flight service and has been involved with the training of flight service personnel. And for over 20 years, she has been involved with flight attendant emergency procedures and training at American Airlines. We ask Kay to come up here and talk about cabin crew and flight crew coordination.

MISS AVERY: I guarantee this will not be long. I did not really find out that I was going to be able to come to speak to this group until yesterday morning. So I do not have a paper, just some general comments that I hope you might be interested in.

I thought you might be interested to know about flight attendant and crew coordination with the cockpit crew members.

That is sort of a central issue which a lot of pilots consider very important, from a procedure angle. And I thought I might talk -- there are doctors in this room -- briefly about our flight attendant medical training that we do at American Airlines and then lastly, a little bit about cabin safety and our concerns.

And we have some real concerns there with recent incidents that have been happening. On crew coordination, our procedures -- remember, now, I am speaking just from one airline standpoint and every airline has different procedures.

One of my jobs is to handle coordination of all flight attendant procedures to and with and from the pilots. That is why I am down in our Fort Worth

offices because the flight department is there and has been there for some years. So all I have to do is walk across the street, or make a telephone call so we can coordinate. Another reason is that our certificate to fly is held by the Southwestern Region of the FAA and it is not too far away from the airport. So it makes it kind of a cozy society. I am in charge of all flight attendant evacuation procedures. Now, I do not just sit at home at night and dream these things up.

Our Director of Safety, Mac Eastburn has a tremendous influence over me. We respect him and those procedures have been developed.

All safety general procedures -- and here is an example. The DC-10's, as many of you know, were certified or at least American's were, with door armed lights in the cockpit so the crew knew not only that the door was closed, but it was armed too. Therefore, we could not depart from the gate until our pilot got on the ball and armed that door immediately. Whereas on all our other aircraft, the doors are armed as we push back. Okay. "Flight" has removed those lights from the cockpit now and we are going to change our procedures so they are standardized and every aircraft is the same. That is not a real exciting procedure, but, you know, it is interesting, I thought.

I do furnish flight attendants with evacuation procedures and they have published a checklist, planned emergency checklist, and it is published in the pilots' manual. And we welcome any pilots to come to any of our emergency training sessions. It is often difficult to get them to do so because recurrent emergency training usually lasts till midnight. That is when the aircraft are available. We use the actual airplane for the drill work in the recurrent training.

We have simulators in Fort Worth which are very lovely, and very expensive for the initial training. One thing, and I think our pilots understand this -- our evacuation procedures, as such, the evacuation of the airplane, is taught without the crew present at all.

That is kind of a grim overtone, but we are supposed to be able to act on our own without their intervention. We will not wait for them because they may not be there in an accident. So that is the basis and philosophy of that particular training. If anybody wants to ask me about that in the workshop tomorrow, I will be glad to discuss it. The reason is important, a quicker evacua-

tion. I think we have seen in so many airlines evacuations, the cabin crew is waiting for the cockpit to say "Go," and in those precious seconds, if a fire occurs, time is lost.

Our vice president of marketing speaks with Mr. Ehmann, Captain Ehmann, the vice president of "flight." But I am talking about safety training as such, not the big corporate philosophies. American's medical training more than complies with any FAR specifications. I am sure you are familiar with the FAR; it is rather general in first-aid and medical training. We teach and have hands-on training on resuscitation. Now, I cannot honestly stand here and tell you we teach CPR, but we are awfully close to it. We call it MMR and CCC, mouth-to-mouth resuscitation and closed cardiac compression.

The reason is time. The Red Cross Association training is a full eight hours. We do not have eight hours to spend. But we do spend the money to have mannequins at the school and at every one of our flight attendant bases, we have half an "Andy" there and every year everybody compresses and blows like mad.

And I can tell you, I think our results have been pretty good. I am very proud of our flight attendants in what they have attempted to do because we know we have people who are sick once in a while on our aircraft, some passenger deaths, and they really have tried.

I think they need all the accommodations possible. We only teach -- and some of you medical people might be interested in this. We teach flight attendants to treat symptoms only. They do not diagnose.

Back with Orville and Wilbur when I became a flight attendant, I was taught about stroke and heart attack and shock and everything else. And then with the concept of Dr. Leather, who some of you might remember, he changed that.

We are not nurses. That year is long gone. We are not professionals in the medical field. We are just treating what we can see and, you know, that works. People with a little knowledge start treating something -- they start treating things that perhaps should not be.

We stay away from that. It is called levels of consciousness: Is the person breathing? Tilt the head back. Does the person have a pulse? You know what you can do if they do not have that.

If you lay them flat on the floor, there are basic things to do. And we follow a regular checklist. So far it has been pretty successful. We can do a better job. I am not quarreling here. I think we do a much better job and I am trying to even improve that checklist.

We teach within the confines of the medical equipment that is available to us in the aircraft. A lot of suggestions come from various medical groups -- why don't you add an airway -- those things that you stick in your throat. So if you have a more sanitary blowing procedure, well, that takes a little training. You do not want to gouge something back in someone's throat without that.

Also, things in the aircraft like to be stolen and that is probably our greatest problem. They do not stay with us very long. That is why we do not have those, and we have done pretty well with just what we have. We teach them how to put on a splint and we have not used a splint. We do teach them how to do it and why not to administer burn ointment unless the passenger requests it and how to put on a bandage compress. We have used that; and how to wash out an eye irritation, and so forth.

Cabin safety then is the end result. We have procedures to have flight attendants report to us what is happening. This is the best of all. It is called OP4. Who cares what number it is. Whenever there is a medical emergency on the trip, they come to us in Fort Worth first. We in turn send them to Dr. Wick who is now our corporate medical director, but not before we get a chance to read them and know what is going on medically on our aircraft every day.

We certainly cannot dream things up, although we think about people who are going to get sick on this, this and this. We know what they are getting sick from. And I suppose when we get into the rocket era, there will be a whole new set of disorders that might come.

We are not perfect. We learn from everyone, and mainly our flight attendants in this manner. In flight cabin safety, and I bet we are going to discuss this in our workshop tomorrow, safety on the work environment is certainly of concern to American Airlines and every company that I know of.

There are some real serious issues that are facing us right now. The hijacker. That is not too funny. And the hijacker has a volatile liquid now as a weapon and I am sure many of you have seen the FAA film of what happens when

a volatile liquid is ignited in a cabin.

It just cannot happen. And it is pretty bad, I'll tell you. So we are very concerned, particularly our director of safety and other interested people. What can we do to prevent this character from getting on the airplane?

These devices in the cabin aircraft -- out of the cabin aircraft -- become very lethal as you get into pressurization systems. Here is what we are, and here is where we in flight service and the flight department work as a team.

And talking about hijacking, and we really do, we share the same training aids. That happens to be a B box. It happens to be a B box, QCS film and we share the same procedures. We share the same room if we wanted to, to look at this training tape.

We have other films that we also share that the FAA has given to us, or we make our own. And we do share them with the pilot. Share them, they make them and we take the advantage of it.

In the case of hijacking, and we have had several, it really brings the entire crew together. I guess psychologists would have an answer to that. But it is very noticeable and it is very heartwarming following a hijacking, they have comments in writing to me like "We think our captain was great." Boy, is that nice to see. And the most recent hijacking that we had was at our one year's anniversary party at the captain's home.

There is another area not quite so potentially serious. What about the unruly, the apparent drug addict, or the unruly passenger? Now, we will not spend time addressing that.

But, it does not happen that often. We have over 1,100 departures a day and if we get one incident, we have had it. But one is almost too much. We at American are definitely addressing that subject. Our director of flight service is extremely concerned and we are going to do something to help the flight attendant. We cannot say "no," drug addict, you cannot board our airplanes because we do not know. But we certainly can do a little better job in training our flight attendant how to handle this so we do not have to call a doctor or a cockpit crew member back to help us out.

I have just briefly mentioned, I will be anxious to talk to any of you. about these subjects, crew procedures, coordination, flight attendant medical



training which we are quite proud of, and our interest and concerns to improve the welfare of our flight attendant in the cabin environment.

I am anxious to hear your inputs on this and I very much look forward to learning from all of you in our workshops tomorrow. Thank you.

DR. DIEHL: Thank you very much, Kay. Because of the lateness of the hour, I think we are going to have to forego the questions.

SESSION 3  
(July 9, 1981)

DR. DILLE: Our major activity this morning is going to be to hear summary reports from the workshop leaders from all day yesterday. Before we start that, however, we do have some unfinished business from Tuesday's program and we have an invited speaker from Tuesday afternoon, Captain J.E. Carroll, Vice President, Flight Standards and Training from United Airlines to give us a presentation this morning.

CAPTAIN CARROLL: Good morning, everyone. I recognize that this is a little out of order and is not what was originally planned to be given; and while the FAA may be an arm of the U.S. Government, my wedding anniversary was Tuesday and my wife carries a little more weight than the Government.

And so I thank you for bearing with me for being out of order. I think I have some things which I know are of interest to me on the subject of human factors and I hope that you'll find that it fits in a little bit with what you have been discussing.

I recognize again that being out of sequence that you are about ready to put the thing to bed from the standpoint of workshop reports; but perhaps this will add a little bit more to your thinking.

And while it may not change the final report, I think it will at least augment some of the things you've been discussing. Human factors is a very important subject and in particular, I'd like specifically to talk about the relationship in the human factors area of cockpit resource management.

Now, attention to human factors has been primarily addressed in the area of design of equipment, its location in the cockpit, and to items of comfort and ease of use such as, the seats, manuals and associated reference materials; whereas, the need for training in human factors as it relates to the interaction of the cockpit crew members has for one or more reasons either been touched on lightly or totally neglected.

The organizations that have pursued training in this regard in most cases have approached it on an one-time basis and even then have scheduled just their captains for the training.

Nevertheless, the recognition of the need for addressing the problem has continued to be evident in the industry and today more and more attention is being paid to this particular aspect of human factors.

This recognition for the need of training in what United Airlines has termed cockpit resource management is supported by many accident reports and incident investigations. During the past ten years, over 60 percent of the air carrier accidents have had as one causal factor some aspect of poor cockpit resource management.

If we were to add to this the accidents that have occurred in corporate and general aviation, we would find that more than 80 percent of all accidents have had a similar ingredient.

As a result of this mounting evidence, the NTSB has on an increasing basis made recommendations for training in this area. As a personal example of United Airlines, December 1978, a recommendation was made that some form of assertiveness training be undertaken to ensure vital information being communicated in a more positive manner.

The FAA, too, in recognition of this mounting awareness has been meeting its responsibilities in part by holding a series of workshops such as this to try and assess the approach to be taken to address this growing problem.

Other forms have also been used to pursue this issue. In 1975, ICAO Technical Conference that was held in Istanbul had as its overriding theme the problems being evidenced in the area of human factors. In June of '79, NASA held a symposium in San Francisco, the subject of which was human factors as it relates to resource management training. In April of this year, there was a seminar at Ohio State on the same subject.

In December, the ICAO Technical Conference will again touch several agenda items addressing the concern with human factors as it relates to resource management. The problem confronting us all might be summarized in the following manner: Why does a person who was carefully selected, highly trained, properly checked and licensed, physically fit, mentally well-balanced and unusually well-paid sometimes perform in less than the optimum fashion, and this, despite being aware that the penalty of human error can be catastrophic.

United Airlines' attention was drawn to the magnitude of the situation rather dramatically in December of 1978. Our accident at Portland in which the fuel supply was exhausted was a graphic illustration of what can occur if the cockpit resources are not properly managed.

It also caused us to focus on the fact that our last three major accidents could be directly attributable to poor resource management in the cockpit. In each of these accidents, the aircraft could have continued to fly successfully if actions by the crew had been more properly directed.

In 1972, our 737 crash at Midway was contributed to, in large measure, by a lack of awareness in the cockpit when after an expedited descent, the speed brakes were left in the extended position.

In December, 1977, our accident at Salt Lake was again a result of a series of events which could result and be termed poor cockpit resource management. As a result of this recognition, United made a decision in February of 1979 to use its training resources to establish a program that would preclude as much as possible any accident that could be attributed to poor management resources available to the cockpit.

We subsequently researched, at length, programs of this kind that could be implemented by foreign and domestic carriers. We found as we stated earlier that the programs while varying in length and content were all essentially one-time events and directed almost solely to their captains.

As an example, one of the best courses available on the subject has been created by KLM. It is basically designed to take to the field and it is composed of 15 AV packages which run approximately 30 minutes each for a total of seven or eight hours.

It is, however, passive, not participative and it is planned to be given just once. There is a second part of their program which lasts five days and is participative, but this is only given to their captains.

After reviewing these many programs, the ultimate conclusion was that human behavior cannot hope to be changed on a long-term basis by exhortation alone, nor by any brief exposure to education on the subject.

As a result, though still not sure of the program to be followed, we made an initial decision that any training that would evolve must ultimately be addressed to all cockpit crew members and must also be done on a recurrent basis.

The complexity of the problem caused us to have to spend the initial months of our deliberations just attempting to define the problem if only to

determine how it might be specifically addressed.

Our indecision was based on questions such as: Can you train people for command; Is leadership an inherent trait; If you emphasize command or leadership to all crew members, would it tend to suggest committee action in the cockpit, since all crew members would then lean more towards the exercise of command or leadership.

The more we reviewed the problem, the more we recognized that the emphasis had to be primarily on cockpit resource management. Our recognition stemmed from the fact that as our equipment has advanced, as technology has improved, as responsibility has increased for both the size of the equipment and the size of the cabin crew, our captains had to become more and more a manager than ever before.

The analogy, especially if you were to use all wide-body equipment, would be that the captain of an ocean liner was responsible for overall management of the ship. We reason too that not only must management skills be improved, but also the ability of each crew member to work in harmony with others has to be addressed.

The endless combinations of personality and management style that are possible in our cockpits pointed up the need for each individual to be aware of not only the impact they can have on others, but also how with this recognition, they could then be more effectively interfacing with all those with whom they come in contact.

Our goal was to have a more efficient, proficient and safe operation and we ultimately verbalized this goal as striving for synergism in cockpit resource management. We sought outside assistance to help us establish a proper program.

One of the consultants we engaged was Scientific Methods, Incorporated, of Austin, Texas. They are the originators of management grid training and we decided that the grid language should be the cornerstone for the training we were about to embark upon.

We had investigated other approaches, but recognized that the frame of reference provided by management would serve our purposes best.

In addition, we also engaged a second consultant, Dr. Lee Bowman, Professor of the School of Education at Harvard University. The intent was to have Dr. Bowman oversee the entire program to ensure that our educational approach was proper.

Our developmental work began in earnest in July of 1979 and we have now finished the first two phases of what is to be a multi-faceted program. The initial phase implemented the 1st of March of this year and now completed is a self-study program consisting of seven booklets which were mailed to all our cockpit crew members at two-week intervals.

In recognition that we have over 5000 cockpit crew members at United, we felt that the initial step had to be a self-study course so to provide the background for the need of the program, to establish the frame of reference for language previously referred to and to provide a foundation for subsequent training.

For the second phase, we have developed formal seminar training to provide the opportunity for firsthand application of the principles of a self-study program. The seminar program will be in full swing this Sunday, the 12th of July; and we will initially have all of our management, instructors, and line captains attend.

The seminar will provide a role-playing opportunity to confront the dilemma situations which are true to the experiences that occur on the line. These dilemmas assume the presence of the proper professional skills, but require the exercise of effective interpersonal relationship skills if they are to be properly addressed.

Feedback on each individual's effectiveness will be provided by their fellow participants in the seminar. It was incidentally a considered decision to initially send only the managers, instructors, and line captains to the seminar for two reasons: First, it will take a year just to process this group through formal seminar experience and to schedule the first and second officers simultaneously would have stretched the program over a three-year period before all of our captains had had this training; secondly, it was felt that with a new experience of this type and the potential sensitivity of the training, it would be best to first have the captains interface with each other.

This, we believe, will eliminate the concern for the impact of any feedback we might receive about the management styles we have on subsequent line operation.

If the feedback was to be given by first or second officers with whom they might subsequently be scheduled, we could have the potential of creating a less than desirable cockpit atmosphere.

The third phase of our training plan to begin in October will be to incorporate into our loft scenarios the principles to assume in the self-study and seminar phases. It is here that we believe the first real payoff will have begun to be realized.

Although, first and second officers will have had, at that time, only the self-study course, it should provide sufficient background to enable them to participate effectively in this loft training.

Part of our plan is to take video or audio tape, the loft experience, and then in a debriefing session, take the opportunity to review how the scenario was flown. Specifically, the instructor will spin the tape to the particular portion of the flight to be reviewed, play it for the crew, and say I want you to discuss among yourselves why it went so well, or the alternative, where it might have been improved.

The crew will then in their discussion provide feedback to each other on the positive and negative aspects of the flight. At the end of their discussion, the tape will be erased by the crew so they will not have any concern for the tape possibly being used in any way in the future.

Subsequent phases still being developed will provide a formal seminar experience for first and second officers on the upgrade to the next higher seat. This formal training at that time should enable them to recognize how they, in their new position, will find themselves with new contributions to make or new resources to manage.

The training will also be provided in a seminar atmosphere for any new hired crew members as they join the airlines, but with the same intent that will be present for the upgrade training for the first and second officers. In recognition of our flight attendants as an integral part of our crew, it is our plan to give a form of this training program to both the incumbent group and to provide it as part of the training given to new hires.

As you can see, this is an ambitious, long-range program; but it is well underway and to date finding great acceptance on the part of our cockpit crew members; and recognition of a need to have this acceptance we had from the beginning has helped to give representation of each of the working groups and as part of the steering committee responsible for the overall program.

They also have proceeded very cautiously. As an example, we first tested the self-study course with a cross section of 175 crew members before finalizing it and having it distributed to the entire group.

We have also run three tests of the seminar with a representative sample of management and line captains prior to formally implementing this phase and we will continue to test each subsequent phase of the program as it is developed prior to its implementation.

We also recognize that when dealing with people and the types of training that this overall program encompasses, it should never be considered a final product. It must remain dynamic and therefore open to change at any time. Our tests caused us to revise the first two phases several times, but the changes became smaller as we gained experience.

Change, however, must and will be a continuing part of the overall program. We have found as knowledge of our efforts has spread that there has been a growing interest in pursuing this form of training.

Most recently, the Canadian Department of Transport and two Canadian airlines have expressed a desire to investigate further. There may be ultimate commercial opportunities in providing this training; however, the goal was and is to address an obvious need in the area of human factors training on United; specifically, to enhance the interaction and smooth functions of our cockpit crews.

The key word is synergism and if we are to be successful, it will become an expected and recognizable ingredient in all of our cockpits.

Thank you.

DR. DILLE: Okay. We will get on now with the summary and because of scheduling, we are going with Dr. Rose first and the workshop B on biomedical and behavioral factors in the performance of air traffic control specialists.



There is no established order after that. So if any of the other workshop leaders need to leave, let us say, before 11, come up and tap me on the shoulder and we will adjust the schedule accordingly.

But we will start with Dr. Robert Rose, University of Texas Medical School at Galveston to hear about the air traffic control workshop.

DR. ROSE: Thank you, Dr. Dille. It was a privilege to chair the workshop yesterday on the biomedical and behavioral factors in air traffic controller performance. Our group was small, but I thought it worked very efficiently and effectively together.

The discussion was quite focused and I think a good deal of consensus was achieved during the course of the day. The main topics that we addressed were primarily in the domain of behavioral factors.

We did not spend much time, nor was the composition of our group particularly oriented towards biomedical factors so most of what you're going to hear will be on the behavioral aspects and perhaps some other time, it might be considered a group topic more specifically on biomedical issues.

There were three general areas that we discussed. The first one, which comprised the largest amount of our time in deliberations, was air traffic controller skills analysis. This grew out of a discussion that readdressed the question about what the future was of air traffic controllers. There was a perception among a number of the members of the group, myself included, that the projection for the next 15 to 20 years down the pike was for complete automation of the enroute air traffic control system. But we heard from a number of participants that this was really not so, and that the decision-making responsibility of controllers would still be existent and be needed, required and recruited for. And so I will go into some of the discussion of this.

The second topic was the topic of the work and the social environment, the issues of job satisfaction or dissatisfaction, the problems of perception or misperception of the different groups involving controllers, managers, etc. And I will talk some about that.

The third area on which we spent somewhat less time was the question of system errors and future investigations of those with human factor concerns.

A fourth area, which really was outside the rather strict purview of our group, but nevertheless came up a number of items and I think it is worth mentioning, is the whole issue of information transfer.

It was apparent to a number of members of our group that they were unaware of work, systematic work, the collection of data and information deriving from those data, that had been done by other individuals, either within the FAA structure itself or affiliate groups. There was some distress and concern expressed several times during the course of the day that individuals knew of various studies that had been conducted, the nature of data bases that had been assembled, and although they heard about them, were unaware of their specifics.

Perhaps, I think the workshops and the evolution and birth of them may indeed reflect a certain awareness of this problem at the FAA management level. But nevertheless, one might consider the possibility of a more systematic effort to facilitate information transfer among various groups which are working with various aspects of human factors. It is, I think, important to try to get people not only to talk together, but to try to become more systematically aware of work that has been done in the last several years which is relevant to the concerns in system errors, for example, of stress, illness, or work on skills analysis, etc.

Most of the work that is done by various groups does not reach the archival literature, is not published in the sources or documents to which most bibliographic services are directed, like abstract services, etc. Consequently, I think that there should be some increasing concern directed to this issue which is that we are at times re-inventing the wheel or, if not re-inventing the wheel, not learning that other groups have done some relevant work.

There was considerable consensus among the individuals in the workshop about a need to develop a much more comprehensive and clearer understanding of the actual tasks and skills involved in air traffic control work. Numerous individuals pointed out that there is indeed some consensus in terms of over-the-shoulder monitoring. When one watches an air traffic controller and he accepts the hand off and works the plane and hands it off again, one can develop a flow chart of what the actual objective description of the events are in that process.

However, the ways in which the perception of the controller, the cognitive functioning, the decision-making that he employs to accomplish these

tasks has not been, as of yet, specified in objective terms.

And as I just said, this is despite the fact and we were aware of the fact, that individuals who are experienced can look over the shoulder of the individuals who are doing the controlling tasks and come to some degree of consensus. There is interrater reliability, in other words, about the nature of conduct of that task.

However, the specification of it is not very well done. There are indeed some strategies or paradigms, which are available that have been developed from cognitive psychology and they can be utilized in trying to dissect out, in terms of what was referred to as micro-analysis of the tasks, what controllers actually are doing in objective terms.

Dr. Tucker, from Catholic University, gave an example of that and other examples that can be used in a simulation environment and computer interface.

The need was generally agreed upon by all participants, and the strategies involved in establishing that and the advantages realized are considerable.

The emphasis was repeatedly made about the need for an objective measure of performance, not just subjective interrater reliability, and a number of advantages were agreed upon by the group.

Number one, it was pointed out that a shorter training time would be accomplished. Number two was the goal of a better specification of the specific kinds of cognitive and perceptual skills that would be needed for recruitment and hiring.

Number three, an improved opportunity for rewarding excellence of controllers. This is a problem that is a two-edged sword as has been pointed out; whether or not we want to reward excellence in terms of actual controlling abilities or not, I would argue for it, but there was some discussion about the politics of that particular issue and I think that deserves some more discussion.

The fourth was improved planning for interface of automation strategies in human performance. I will talk about that just a bit more in just a second.

And the fifth is an area which appeared kind of on the surface. We did not get into that in great depth, but nevertheless there was some discussion earlier in the meeting about the question of specification of the particular associated attitudes or psychological perceptions of controllers. Along this

line, what do we want to look for in the future controller, ten years, 15, 20 years down the pike? Do we want to look for the individual who is a better information manager, as one might phrase that, first, as a controller who is controlling, who owns the air space. There was some discussion about that, and indeed people felt that if there was a better specification of what the actual skills were, what the tasks actually involved are, in an objective way, one might be able to have a better idea of what kind of personality might be associated with the acquisition or the learning of those skills.

A number of strategies and ways of approaching this were also discussed. The first tapped into an observation that we made in our study of air traffic controllers in the 70's. We found, using peer rating methods for measuring technical competence in which individuals were asked to rate individuals of their teams or sister teams in terms of three areas, technical skills and general competence and ideal team, that there was considerable consensus among the controllers that could be observed in terms of identifying those individuals who were indeed considered the stars or the ones that could really, quote, "obtain the picture quicker" or who were most adept when things got hairy, to work effectively and efficiently when separating a complex picture. Some one-seventh to one-ninth of the controller work force were considered by their peers to be excellent in this area, whether or not they liked them personally.

One might go ahead and identify that group by peer nomination and try to study them as particularly skilled in the subjective sense and try to use them as one population to study in terms of micro-analysis of objective tasks of the controller.

One might do it under two different conditions. The first relates to the analysis of what takes place in the information processing, cognitive decision-making, the kind of learning algorithms or strategies individuals employ in more routine kinds of tasks. Some 70 to 90 percent of the time, the controller is separating two to three to four planes. Somewhere between five and 15 percent of the time, it varies, the controller is separating aircraft in larger numbers in terms of transitioning aircraft in approach control, for example, and anywhere from seven to ten aircraft.

That is rare. Are there different tactics or strategies that are actually employed by controllers in the two different situations? Are there different

ways that they approach it? We think so.

There was a general consensus also about the issue of establishing a better interface in communication and future work -- taking the information derived from this micro-analysis and our understanding of how the controller conducts his work, his tasks, and what strategies he employs with the different plans and options that are being considered for increased automation. It was interesting for me and for several other members of the group, who are not particularly knowledgeable about these technical aspects, to learn that one way of conceptualizing the technical developments for the future of the increased use of computer technology, is that it really provides the controller a potentially increased amount of information more readily for him to make decisions.

And there has been some ardent discussion about this in terms of what is the model for the 20 years down the road. But nevertheless, there was general consensus that, for clearly in the next two decades, the controller will be taking this increased available information and using it to make certain kinds of decisions.

One of the proposed strategies was to take controllers, assuming we can develop this better understanding of the objective workload, and place the individuals in three or four different models utilizing "automation" and increase air traffic work and see which ones mesh better. One could use a simulation environment to do this.

But I think the message between the lines of the group discussion was the issue of increased communication between those concerned with how individuals do their tasks, both looking at objective and subjective phenomena, and trying to work closely with the individuals designing the kinds of information and computer transfer of information to the individual. There was some concern that this was not working, that the groups had not worked in as close collaboration as they might, and there was some suggestion that there really should be a planned strategy for the future.

The other area that fell out from this, in terms of strategies, related to the issue of the need to look at the controller and the information provided by the computer, the planning and decision opportunities provided by the computer and to look at, at the same time, the questions of the controller/pilot

interface. It became clearer as the discussion went on that there were several problems potentially developing in terms of various planned strategies, in terms of who made what decision and what impact that had on the other individual, who had what control, who had what responsibilities, and that there was a need to facilitate that dialogue early on in the planning for the next ten or 20 years.

There was also discussion about the possibility of evaluating a couple of more objective kinds of environmental issues. Number one was the assessment of whether or not the particular configuration of the work environment, in terms of the large rooms and long corridors, really provided an atmosphere which initially made it necessary to facilitate communication among the controllers, but now many provide an atmosphere which may be distracting because of the large amount of background noise, and some work on this might be done.

Secondly, and along the same lines, some ongoing investigations should be reinforced, in terms of looking at whether the controller work groups should be one person, or should be two or three. Other discussions came out, and more technical ones, about the use of colored video displays and the voice actuated data input into the computer because of communications back and forth between controller and pilot, should these data about the speed or altitude of the aircraft be entered by voice input to the computer.

In general, the group was in considerable agreement about the importance, for a number of reasons that I have tried to outline, of what the actual tasks are in objective terms. This would have spin-offs in terms of hiring, training, and a better understanding of the future man-machine interface.

It is interesting that in the course of the discussion we started out by saying what is the need and what kind of skills does the controller have to have in the future. But it became very apparent during the course of the discussion that we really do not know today actually what the controller is doing and that is obviously the basis necessary for projections for the future.

A second topic relates to the issue of air traffic control work and the social environment interface. It was recognized in the group and there was some discussion relating to the fact that there is obviously, and known to

many individuals who have participated in discussions with controllers, an awareness that there is a presence of significant conflicts.

They are often, but not universally, significant distortions in their perception of management, management's goals, decisions and missions by air traffic controllers, and at the same time, significant distortions of the motivation, interests, and attitudes of controllers by supervisory and management personnel.

There are series of events and situations with labor management, union management negotiations issues in which there is a kind of formalization of these distortions and, unfortunately, the perpetuation of these has significant effects in terms of the issue of job dissatisfaction. It kind of fans the flame unfortunately.

There was some discussion early on about the need for improved training and education in terms of management skills, and I was interested in Captain Carroll's presentation.

It was excellent in terms of the management grid which, for those of you who do not know about it, is conceptualized as two axes. One axis is the concern for mission, for getting the job done, and the other axis has to do with the concern for individuals or people. And there are 9,1 administrators who look all at mission and none about people, and 1,9 individuals (and I may have the axes mixed up), who are all for people and not for mission. Their purpose is to try to move people toward a 9,9 configuration taking into account both the job that has to be done and the individual's feelings and morale at the same time.

In any event, I was reminded of that as a possible strategy for the training of future supervisors because it was commented that indeed most of the supervisory personnel, if not all, come from the air traffic controller work force. The skills inherent to doing controlling work and the kinds of recruiting strategies and what we look for in controllers have to be translated into management skills and that is not an easy jump. Just like it is not easy for pilots or any other group, and we often are confronted with the dilemma of being promoted to a level of incompetence, which we are all aware of. The problem was an increased need for education about management skills and personnel skills for many supervisors.

It was also mentioned in the context of this work-social environment interface that it was important that we make more systematic study of the sources of feedback that individual controllers receive in the course of their day.

It was pointed out that Luin was referred to as task feedback, was did one make the correct decision in issuing instructions to the aircraft and facilitate separation, versus the concept of evaluative feedback. Evaluative feedback often has to come in the context that "you did a good job," and it comes from person to person, not just in terms of the fact that you did not have a crash, or mix a pair together.

There was considerable concern about looking at this issue of feedback to develop and improve the issue and to develop ways of improving the level of job satisfaction perceived by the controllers.

It was also suggested as a strategy in the recruitment and early training of controllers that more emphasis and more attempts be made to explain the nature of the air traffic controller job to the young developmental controller and the issues of the relative short-lived nature of controlling. The period of time that the controllers work after they become fully qualified journeymen controllers is somewhere in the vicinity of 15 to 18 years. Then, the level of activity of work that the controllers engaged in, training, after early 40's drops rather considerably compared to their younger colleagues ten years their junior.

The issue of the changes or potential changes in promotion schedules should be explained so individuals know more about the career line. And the concept was mentioned that the analogy was more like the military where you can retire after 20 years. Some consideration should be given perhaps to more systematically looking at those issues and communicating them early on before someone gets into being a controller.

There was also the mention of more attempts to structure dialogue and to enhance participation of controllers in problem solving, perhaps through peer nominations via the controller work force which could or could not be within the PATCO structure.



There is a perception among individuals that they do not have that. Indeed, when there has been an attempt, sometimes from management, to proceed that way, it has been blocked by the union, and there are a number of charges and countercharges that have moved back and forth; but nevertheless, there needs to be an increased focusing on the goal to try to develop systematic participation of controllers, both on a simple level and also for long-term planning of future systems.

There also was mention about the need for increased research and investigation on the potential beneficial effects of reducing perceived job dissatisfaction on health and performance, and there is considerable literature in the management field about the fact that job dissatisfaction is associated with a variety of problems in performance, and it has a future risk for a negative health outcome.

The final area, which we did not spend a great deal of time on, came up towards the end of our day and was the discussion of system errors, in which a number of points emerged. We did not develop as comprehensive a number of suggestions about future research strategies; but nevertheless, a number of things came up which individuals had some consensus about.

The first related to the need to assess quite carefully the quality and the representativeness of the data base of system errors. It is well known and established that there is a significant underreporting bias; it may vary from facility to facility. The issue of the underreporting bias is affected, of course, by policies of immunity and/or anonymity and whether or not conclusions that have been previously derived from an analysis of this data base are valid. It was pointed out that there is a need for this kind of work on system errors not to be a one-time shot, but to be an ongoing issue across facilities, across time.

The need to assess potential detrimental effects of shift rotation on errors was pointed out. It is well established now in the psychophysiological literature, well documented as a matter of fact, mostly in Scandinavian work, that shift effects have a negative effect on health.

The body does not readjust rhythmically in a short period of time and this has been studied in literature and reported recently in jet lag going from Europe to the United States and back again in a number of systems like

cortisol and melatonin, and there is work in the Scandinavian group on epinephrine excretion and so on, indicating that if you shift even as infrequently as once a month, there is considerable disruption of basic biological rhythms. There are some studies, though not as many, on decrements in performance.

Now, individuals often elect to engage in shift work because of the freeing up of weekends, long periods of time, etc. However, there is enough significant literature to raise questions about this and one should proceed to look at whether or not there is an increased risk of errors when one recently comes off a significant change in shift rotation.

There is a need to clarify whether or not there are very different kinds of factors operating in errors when they occur at times of low traffic and when there is little going on, there are one or two planes on the scope, which may be related to inattention, boredom and distractability as compared to the kinds of errors that may occur when the system is really busy and the controller is working a large number of planes. The second error type may relate to more task complexity and it is not clear yet whether or not -- what proportion of the time that errors occur.

Indeed, if lower levels of activity predominate in terms of percentage of work time, say 2/3 or 3/4 of the time, and if during that period half the errors occur, it means that heavy workloads occupy the relatively small percentage, 1/2 to 1/3 of the time remaining, yet contain half of the errors. That is significant. In other words, one has to look at these -- it may be very different kinds of problems inherent in system errors in these two different situations.

It was also pointed out that the FAA should address perhaps more systematically not only what went wrong, the system error, but why it went wrong. That suggests the possibility of more intensive interviewing of participants, supervisors, their perceptions, a kind of a psychological autopsy of the problem after it occurs as well as the more objective kinds of analysis that is currently done.

And I think, finally, the issue was raised about the need to integrate and investigate to what extent job dissatisfaction contributes to system errors.

That is it and thank you very much.

DR. DILLE: I took some furious notes on one point that Dr. Rose made. As you recall on Tuesday afternoon, Drs. Tucker and Sells referred quite liberally to CAMI's studies on air traffic control specialists. The 4th Workshop in this series was held at the FAA Technical Center in Atlantic City about two months ago and it was on the topic of air traffic control. There were, of course, no formal presentations at the workshop by anyone from CAMI. And several participants have reported back to me that they did not find many attendees at the Technical Center who had ever heard of CAMI, let alone of any CAMI studies. It would seem that a major function of our workshops would be to improve communication on the topics selected for emphasis, but I am not sure in the biomedical-behavioral area that we have been doing that effectively, because again, our work was not much in evidence at the previous workshop and the relatively small group in the air traffic controller session here has not significantly expanded our range of communication. So, we may not have completely fulfilled our objective in that particular area. Another workshop yesterday was a relatively small, but enthusiastic group on aircraft accident investigation, and at this point, I will ask Dr. Bob Wick, who is the corporate medical director from American Airlines and the workshop leader on aircraft accident investigation to give his summary report.

DR. WICK: Ladies and gentlemen, as Dr. Dille mentioned, we had a very small, but enthusiastic group. We alternately went from the verge of fisti-cuffs to cheering and celebrations about the great truths that we had uncovered.

Actually, we did discuss some 15 different items and in quite some length with a varied group consisting of physicians, forensic dentists, airport managers, airport engineers, and people with a wide variety of background which contributed to the wealth of material presented for all of us.

The first and the fundamental question that we really asked ourselves was is it necessary to investigate all accidents. And, of course, this generated quite a bit of discussion for several reasons.

We concluded among other things that the difference between a fatal accident and a minor accident and sometimes an incident in which no accident occurs really is minuscule and sometimes a matter of chance, so that the investigation of accidents and other incidents is useful, but it is not necessarily essential in terms of all encompassing efforts.

There are, again, finite limits to the amount of time and power and money available for investigating such accidents. As an experienced accident investigator pointed out, that time after time after time we can classify the causative accidents into about two or three or four really major areas, many of them beginning with the initiation of poor judgment on the part of a pilot involved. The areas of strictly medical accidents and structural failure accidents are way, way down the list.

In fact, they're so small as to be not a particularly fertile area in which to work for investigation at the present time. The area of judgment, however, on the part of the pilots and crew members involved is, of course, another story.

We concluded, I think, that the investigation of all accidents while desirable is certainly not a practical end at the present time and that a thorough investigation of a representative sample of accidents is likely to provide us with much more useful detail and much more useful information on which to base further work in this area.

As you know from the outline, there were a number of areas suggested to us for discussion. We did briefly touch on most of them, but I must say that in many cases, we elected to defer those discussions which were more properly the responsibilities of some of the other groups.

One such area that we mentioned very briefly was the problem of instrument reading error. While it is true that it plays a large part in some accidents, it is also an area in which work can be done prior to the crash just as well as after the crash.

There is nothing unique to the postaccident investigation, for example, of errors in instrument reading. We did comment, however, that visual problems and visual limitations were rather significant and a number of us in that group who are active aviators shared one experience in that the problem in moving from aircraft to aircraft or flying new aircraft is often one of visual skills.

Those of us who are middle-aged -- I'm not middle-aged yet, but that I have to define as ten years older than I am, but unfortunately, of course, that moves up every year. Those of us who do have bifocals and trifocals and quadrifocals and so forth all had the common experience of having the difficulty,

not necessarily with the flying per se and psychomotor skills involved, but actually in just locating and reading instruments, switches and so on and so forth. However, this is work, which can be done as well prior to a crash, in fact, had better be done prior to the crash. The postcrash investigation in this area is not a particularly fruitful area.

We spent a great deal of time discussing some of the crash injuries which occurred and in particular, we discussed a number of areas related to seats and seating. The problem of seat failures, after a crash, is one which has attracted a great deal of attention.

In some cases, of course, if the structure itself remains intact, the probability is that the seats will too, in terms of a large aircraft or airliner crash. In terms of general aviation crash, the situation unhappily is quite a bit different and not so satisfactory.

There are a large number of injuries which probably could be prevented by a more adequate and a better design of seat structure and crushable features to the seat. The problem of G loading was discussed at some length, not only in the fore and aft crash, which is the expected direction of crash, but in the lateral area as well.

One area of particular concern which consumed quite a bit of our discussion time was the problem of the vertical component of the crash injury. Dr. Jerry Snyder, who was a member of our group and many of you know is one of the world's foremost experts on crash injury and the acceleration injury was able to contribute, of course, immeasurably to the area in this particular injury.

Vertical components were discussed and while I will not discuss particular brand names within our group, we did discuss at some length certain models and types of airplanes in which the rear seats are notorious for causing injuries.

A related subject had to do with the upper torso restraint and the whole subject of shoulder harnesses. And in that area, we found some rather interesting problems. One of the problems, of course, is in the air carrier aircraft.

The flight deck and the flight cabin crews all have shoulder harnesses and for the most part, they are used. We were unable to identify any accident or

or injury which occurred because of the use of these shoulder harnesses and shoulder and upper torso restraints.

On the other hand, there are one or two reports of injuries caused in general aviation aircraft by the use of shoulder harnesses, but the general consensus was that for every one or two of those injuries, there were a hundred or two hundred or a very large number at least of injuries prevented.

There is no such thing as a perfect upper torso restraint yet, but certainly those that are available are helpful. They do save lives. They should be used and the occasional injury which they do produce is certainly no reason at all not to use them.

We discussed at some length the possibility of shoulder harnesses and upper torso restraints for passengers in the cabin of a commercial airliner and the conclusion was that again it is not a particularly practical thing to do at this time and, in fact, a lot of the information available to us from the insurance companies who are obligated to settle cases of injuries was that the seat belt was used still seems to be a reasonably adequate or satisfactory solution.

There is some work to be done yet in the seat structures and in the seat padding. The environment in which an airline passenger sits, while the actual seat belt itself when used still seems to be adequate.

We discussed to considerable extent an extension of this point, the problem of shoulder harnesses and seat belts in general aviation and commuter aircraft, and we had available to us several dramatic comparison studies in which persons in the same aircraft using the shoulder harness were uninjured and persons in other seats in that same airplane without shoulder harnesses were injured seriously, broken backs and so on.

We think, and we do recommend, of course, strongly that the shoulder harness be extended universally in all general aviation aircraft in all seats. We think that the benefit and the cost benefit will be certainly well within the practical limits.

As a subdiscussion, we considered for a few moments the question of a pregnant passenger using a seat belt and the largest body of information available to us is probably again through insurance channels and our insurance

colleagues, and there were several in that group that were unaware of any suits arising out of the use of a seat belt in the case of a pregnant passenger. That one subject which is often brought up about possible injury to the fetus, as a practical matter, does not seem to be a problem.

We then turned to an area somewhat more medical in nature, the area of alcohol and drugs and we had a rather lengthy discussion. Some of us within that group have had some academic background and some academic experiences and we were able to conclude, or it was presented to us as reasonable information by Dr. Bill Kirkham who is, of course as you know, the Chief of Toxicology branch here, that alcohol at the present time appears to be a factor in about eight to eight and one half percent of the general aviation accidents, a rather significant factor.

This, of course, is a controversial area. It is an area in which there have been large numbers of papers published, quoting anywhere from 1 percent to 41 percent and everything in between.

But Bill Kirkham's data and information seem to be about the best available at the present time, that alcohol plays a significant role in about 8.5 percent or so of the general aviation accidents.

On the other side, the question of drugs arose and again, Bill was able to contribute substantially in this area, indicating that with the exception of marijuana -- that may be an important exception -- but with the exception of marijuana, that drugs, other drugs of all types, drugs and medicines, appear to be a significant factor in only about 4 percent of some 700 fatal general aviation accidents which occur a year.

Gerrit Walhout with NTSB indicated to us -- I find it gratifying -- that about 80 percent now of all general aviation accidents do have a postmortem examination done at the time.

The quality varies a little bit, but frankly, ladies and gentlemen, anything is better than nothing and that is what we used to get was nothing.

We were able to conclude that alcohol is a significant problem. It is not necessarily a large problem. The large problems are again, as we were able to point out and discuss among ourselves, still the problems of disorientation, weather penetration, in general, poor judgment on the part of the pilot in command.

The subject of marijuana was discussed at considerable length and I must say there was a disagreement among us about the use of marijuana and the role of marijuana and the incidence of marijuana use by active pilots.

Now, this is a drug which is used, of course, primarily by younger, relatively younger, people. It is also a drug which is technically very, very difficult to find in the case of a postcrash analysis.

The techniques involved are difficult. They require alcohol swab of the mucus membranes. They do not lend themselves even to the good toxicology work which is done here at the Civil Aeromedical Institute.

Only a half a dozen or so laboratories around the United States are able to make repeated routine accurate analyses for the use of marijuana so that we still have a rather significant question mark, and this is an area in which we would recommend additional work.

We have a significant question about the incidence of marijuana and the role of marijuana in the causation of an accident. Mr. Bill Rorke of Colorado indicated that he is doing quite a bit of work in that area right now and it was his opinion that marijuana may be a significant part of the general aviation accidents among younger people.

There was another opinion from other universities, specifically Michigan and Ohio State, that marijuana use by pilots seems to be fairly small. The young students that are seen at those universities at least appear to be fairly level-headed folks, not too much of the hippy variety or hippy population.

At any rate, we had a rather lengthy, and we thought, fruitful discussion on the role of marijuana and drugs.

Then, we turned to the area of mass casualties and again, this is an area in which a number of us in the room have had, unfortunately and sadly enough, some experience. There were at least four or five of us in the room who were participants in various active phases of the DC10 crash in Chicago in 1979 where we had at one incident 273 casualties, 273 fatalities.

A number in the room also had experienced in the Tenerife disaster in which two 747's collided, and although none of us had been there, there were some people who had quite a bit of knowledge about the Turkish crash, the DC10 crash, in which some 300 people were killed in Paris.



There was some experience available to us from those in the room from the Mexico City crash, from the PSA crash out in San Diego and so forth.

So actually, we had collectively quite a bit of personal experience in the mass casualty area and we discussed at considerable length the tremendous problems which occur when there is a sudden and immediate accident of this nature.

Almost no one, no one, not even the largest number of metropolitan areas in the country, New York, Los Angeles and Chicago and so forth, are really, really prepared for the instant disaster and the instant problems which occur after a major crash.

One of the things that came up, for example, was the subject of body bags. Where does one suddenly on short notice get 300 to 400 body bags? And the conclusion was that we are going to have to call upon the good auspices of the nearest air base or army or military facility which may have them.

The other logistical problems were the location and the finding of human remains. Just no one has 400 to 500 and 1000 stakes just sitting around and flags and waterproof tags, the little things that make a difference between no identification and satisfactory identification, the many, many problems we discussed at considerable length.

The next area that came from that, of course, had to do with the identification of the individuals in the accident. There are a number of aspects. We were fortunate that one of our members happens to be the long-time medical examiner of Cleveland, Cuyahoga County area and also is the Secretary-Treasurer of the International Association of Coroners & Medical Examiners. And the difficulties in identification are many-fold. To begin with, each local jurisdiction, more than 3000 counties in the United States, has its own medical head coroner or medical examiner.

There is a coroner in some of the smaller counties, even in large counties like Pennsylvania, but there is not necessarily a physician or pathologist or osteopathic physician.

It may be a funeral director and it may just be a justice of the peace. His background and legal training may be quite small and most, without exception, are unprepared for the tremendous impact of such a large event in their particular county.

Prior to releasing bodies and prior to burying bodies, they all have to be identified if possible. The pressures are unimaginable and unfortunately -- I speak from personal experience -- the press, the families -- everybody and his brother is there and some people are very helpful, some people are not.

Some people in this room have had quite a bit of experience in that area. It is necessary to identify individuals before a body can be released or before a body can be shipped.

The family wants the remains of their loved ones. In many cases, the identification cannot be made, then other legal maneuvering and manipulations have to be made in order to issue death certificates. All kinds of things, insurance payments, death benefits, and so forth may be held up for literally years without the presence of a death certificate.

The subject of identification then was addressed at some length and we were fortunate to have a very astute forensic dentist as part of our group who had a nice slide presentation on the general subject of forensic dentistry identification, the techniques he used, and so on.

I might comment for the benefit of all of you that in the Chicago crash, we were able to identify about 175 of the 273 folks involved, solely through the use of dental records. That was the only thing we could use. The FBI with their fingerprint team, which is very competent and very efficient, but in that particular accident, was only able to make 15 or so identifications out of the whole group.

As for the personal effects, Dr. Clyde Snow from this area came down and assisted us with the anthropology, and the remaining identifications which were made were made in that area.

About 10 percent of the people on that aircraft in that accident were not able to be identified by any means or all means combined. This is not as bad in the Tenerife crash. I believe of the 200 and some Americans involved, almost 100 of them were not identified and were buried in a mass grave; but

dental records were extremely effective.

One of the problems which comes up, of course, is gathering these dental records and that is an area in which an airline is usually pretty good because it has good communication facilities and we discussed, at some length, some of the problems in identifying, locating, and obtaining the folks with dental records.

The legal responsibilities were discussed in such a case at quite some length. The primary responsibility is by Federal status vested in the National Transportation Safety Board. They are in charge.

However, most local county medical authorities are not aware of this, so there is a potential problem right from the very beginning. Unfortunately, the NTSB does not have internally any significant medical capabilities so that while they have a very fine investigation capability, their area and their work in the medical area are quite limited.

Consequently, they normally delegate to the county medical examiner the responsibility for accident investigation. And it was pointed out by one of our group who has been to a rather large number of these major mass casualty accidents, that almost without exception, every county medical examiner says I can handle it, I can manage it and it takes 24 to 48 to 72 hours for the magnitude of this task to sink in, at which time, most of them become far more amenable to assistance and help and advice. But that first 24 to 48 hours is rather brutal. Lastly, or next to the last, we discussed the role of the airport itself in accident causation and accident investigation.

Almost without exception, all aircraft accidents start at airports or almost all aircraft flights which result in an accident begin at airports. Many of them end at airports as well.

We were unable to identify, however, really major areas of the airport itself in which are causative with a few exceptions, the few exceptions being some of the unusual approaches necessary at airports with peculiar geographic situations.

The problems of one or two other airports that have unusual weather situations dictating abnormal procedure were discussed at some length.

The last discussion that we had with respect to the airports was related to our alcohol discussions in that we considered the role of bars, restaurants and so forth at airports, and our general conclusion was that although alcohol was a problem, there is no particular relationship between the bars and restaurants on airports and the alcohol obtained therein and subsequent alcohol accidents.

Most of the alcohol accidents occur in general aviation. They occur from takeoffs from smaller airports where the bars or restaurants are not a particularly contributing factor.

We discussed very briefly in the postaccident investigation the role of the copilot versus the captain in terms of accident and causation and lack of service. And that has been mentioned earlier this morning, a very fine presentation by one of the small airlines based out of O'Hare. I think it is called United and you may correct me on that one. So we did discuss that at great length; that is an area of training and work within the training facilities.

Last and by no means least, we discussed very briefly, although we finally concluded it was probably not germane to our committee, we discussed the problems of pilot supply. That is to say the fact that with the military requiring longer and longer enlistment periods on the part of their pilots and the increasing number of aircraft in the military, the fact that more and more commercial airline pilots and commercial pilots of all kinds will come strictly out of the civilian and general aviation community.

That is viewed by some as a possible problem, although there is a difference of opinion. Others do not consider that a particular problem. Most general aviation pilots have been self-selected. Once they are through the first 500 or 1000 hours to get through the general aviation or out of the general aviation area into commuter airlines, scheduled airlines and so forth, they have further subsequent training which may fill any gaps which occurred in their education at that point.

That was our day. We thought it most valuable and most interesting. Thank you very much.

DR. DILLE: We will go next with Dr. Stan Mohler, Professor of Aerospace Medicine from Wright State University reporting on Workshop A which is on

biomedical and behavioral factors in pilot operation.

DR. MOHLER: Thank you, Bob. This workshop which was similarly interdisciplinary in makeup identified 28 specific issues that, in the judgment of the group, should receive attention in the near future as direct safety related questions.

Our issues were in three categories, that of the flight management category, that of physiological factors and that of the behavioral factors.

We did ascribe a priority to these topics from extremely important to important, to somewhat important and I will run through them, primarily hitting the extremely important topics and then commenting some on the others.

The first topic that we identified under flight management that should receive additional attention is that of the increasing application of automation in the newer aircraft and even in the older aircraft that are being upgraded and continue to be put in use.

The role of automation in regard to how the human interacts with the new automated devices and how these devices interact with the human so that the human is in command at all times.

This role, we feel, needs attention. The group also felt that the nature of information presentations as currently being evolved; that is, the method of displays of bits of information and the various flight management modes, how this is given in the advanced display so that the crew can make optimal use of these, also needs attention.

The group also felt that the new cathode ray tube displays specifically should be assessed from the standpoint of the human factors implications. These displays can be increased in size, decreased in size, can be made to present information bearing formats, and that particular point was felt to be of extremely high priority for research.

Another area that the group concentrated on is that of operational fatigue management. This question continues to arise. It continues to cause discussions and interactions. There are accidents such as the Tenerife accident, a Lear jet accident at Richmond, Virginia, and others where fatigue per se is found to be a major contributing factor.

And the management of fatigue as a potential safety problem lurking in the background was felt to be of very high priority by this group.

Cockpit visibility from the standpoint of a continuing assessment of the minimum visibility standards, from the crew members' standpoint concerning the external environment, was felt to be a topic for specific emphasis.

This topic runs into the complication that you must maintain structural integrity at the same time you are maintaining the potential for cockpit visibility capabilities and, therefore, must continue to receive attention.

Another area is maintenance of skill by crew members in regard to their specific proficiency requirements. How, through behavioral studies and other techniques, this skill can be properly assessed and maintained was stressed.

The group felt that flight path altitude control was a point that requires attention at the present time. There are various types of displays and various means of determining your altitude at various points in the flight, but there are not any standardized methods by which different crew members, carriers and types of aircraft in general aviation maintain flight path altitude control. This was felt to be a factor. One aside on that, apparently some of the persons are using the oral altitude warning devices as the primary means of achieving their altitude and leveling off, without too much attention to other parameters.

Another factor related to the total design philosophy for the cockpit layout, so that human characteristics and traits are involved in the new cockpit designs and layouts, and from an overview system's approach, was looking at the human characteristics in regard to the cockpit design.

Another concern of the group was that of the various types of aircraft mixing in differing environments around the terminals, single-pilot operations and multi-crew operations. They felt that a consideration should be given to the actual work loadings of the crew members in these different types of settings.

Another factor under flight management is that of the newly developed computer assisted instruction and how this type of new approach to training pilots can be better implemented, so that information is transferred to the pilots with proper achievement of skills.

Those were the key areas that were listed under flight management. Under our second category, the physiological category, it was felt that both the peak and the minimum work loads required in each phase of flight needed attention. Too little attention has been given to the minimum work load requirements and somebody pointed out the paucity of papers given and published in this area where pilots and crew members may under periods of low work load move into an unaroused state and be inefficient at intervening. When an emergency occurs, or not actually responding properly to the appropriate segment of flight requirements are examples of this.

Disturbed sleep patterns were felt to be one of the primary fatigue elements. The group feels that additional specific research on the amount of sleep prior to flight and the quality of the sleep is indicated, as well as how various types of flight disturb the sleep patterns.

In that connection, biological rhythms were cited and although biological rhythms play a role, the group feels that with some of the current large-scale studies going on that that problem is receiving attention at the moment. So that was given one of the middle-type priority levels.

An area that crew members have talked about and some others have talked about but that has received inadequate attention, is that of the long flights and the various flights where the crew is inactive in the cockpit.

They, perhaps, are experiencing dehydration and have not been sensitive to replenishing fluids and nutrition in the cockpit on long flights -- the quality and nature of the nutrition and how it might relate to crew performance and safety.

The areas that have received relatively little attention are the synergistic inner actions -- what the crew might be taking in regard to pharmacological agents, plus cockpit external toxic factors that could normally be present that would not be a problem unless there was some internal chemical substance that would interact.

Cockpit noise and vibration are thought to be a continuing problem that should receive attention. We still have older crew members that come in with noise-induced hearing loss.

And these problems, it was felt, are with us, particularly in general aviation, and require further attention.

Under the behavioral area, the main topics discussed were developing methods of measuring individual performance capabilities. This area, when developed, would enable individuals, for example, to assess changes with normal aging processes, changing due to other aspects, including fatigue for that matter, and any questions of toxic substances, pharmacological agents, medical condition, could be assessed when there was an adequate measure of functional performance capabilities of the individual.

And followup to that, the group recommends that task performance criteria be specified, so that for a specific task you have specified criteria against which the decrements in individual performance can be assessed.

Without the performance criteria, then one has no way of assessing the significance of performance decrements. The group felt that human factors approaches to the cockpit resource management and crew coordination are absolutely essential in the next decade and that this area should receive specific attention.

The group also felt that the area of judgment merited study from the standpoint at first of pilot selection. Initially, you could assess somehow the potential for exercising judgment by the individual at the time of selection and then, along the careers of individuals, have periodic ways of assessing judgment, judgment changes, and training individuals to perform better quality judgments. Some of us felt that judgment training is a possibility and that area requires attention.

An additional area for crew members is that of self-induced stresses. Individuals turn up for the flight with certain stresses. Included in this are cigarette smoking, alcohol abuse, drug abuse, chocolate ice cream abuse -- we even touched on food excess, and various things which actually work to the detriment of a healthy body.

We know that one or two of these alone may be tolerable, but multiple self-induced stresses over a long period of time when combined with sleep loss may be the tipping of the balance in the direction of an unsafe person. In addition to that, we went into, with one of our psychologists, stress coping strategies for persons who can deal with and be trained to deal with, the



normal stresses that occur both in flight and in off-duty circumstances, personal crises, and personal problems that can be brought into the cockpit if the individual does not know how to cope with these particular phenomena.

We then covered one general area as our last topic which is outside of these three because it is more general, and it was felt by the group that the last five years or so of major accidents, perhaps even all accidents for that matter, that are on record with massive amounts of data collected, could be made available to a group of constituted human factors persons who would sift through, take an objective look from another viewpoint at that data, and make recommendations for things that could be done to prevent such accidents in the future.

We do have a summary of each of these topics and they will be available in the final report. Thank you.

DR. DILLE: Last but certainly not least you will hear from Rick Clark from the Flight Safety Foundation who was our workshop leader on the cabin safety workshop.

MR. CLARK : We are going to go through, here, the summary of the discussions that our group had yesterday in the area of cabin safety and human factors. I would like to say that we did not formally adopt recommendations or vote upon things.

This will be a sense of the discussion of pretty much as to what has happened in the previous speeches. The group represented a good sampling of the industry. We had aircraft manufacturers, some equipment manufacturers, operators of aircraft, both from the airline, corporate and airline crew members. We had enough, we thought, of a workable group. It would have been helpful to have had, perhaps, some other equipment manufacturers in some of the various areas, but we feel we did have a workable group.

In the time available, we went through, perhaps, half a dozen topics. The first couple of topics are in the area of human factors in the cabin operating environment and the first of those is problems associated with high altitude flight.

What we are looking at here and talking about were two areas -- air quality in the cabin and oxygen system capabilities or I should say, maximum

pressurization system capabilities.

It was discussed that economic factors have apparently driven both the corporate and the airline operators to higher flight altitudes, and it is simply a matter of saving fuel which is a very significant and growing proportion of their operating expense.

The economic driving forces have pushed us into an operating regime where we are pushing the limits of the aircraft structure, and the limits of the emergency oxygen system to cope with either a gradual or sudden decompression.

Part of the group's discussions centered on the fact that design and test criteria emphasized relatively gradual pressure loss and not the major decompressions that have occurred; they are not frequent, but have occurred.

Part of the discussion went toward the feeling that perhaps as a research area, it is worth looking at the true capabilities, particularly in business aircraft, of a flight crew to deal with a sudden decompression and get the aircraft down to a survivable altitude. This, after all, is a premise for many of the waivers that have been recently granted. We felt that we were in an area of granting waivers where perhaps the technical data are not as firm as it should be.

In the area of air quality (this was an interesting one), again we felt there were no firm conclusions but perhaps some indications that some research was needed. The problem as explained to us showed up in two areas: 1) crew member complaints initially attributed to hypoxia but perhaps not with that cause; and 2) passenger complaints. The passenger complaints, oddly enough, came from consumer complaints to Transport Canada who was keeping track of this type of thing a few years ago. The concern was, that with the goal of saving fuel, we are minimizing the use of pressurization equipment in the aircraft, maintaining an adequate pressure differential, but reducing the overall airflow.

One of the manufacturers pointed out that they are, in fact, in some of the newer equipment, changing the air circulation system to try to improve the interior air quality. They do this mostly as a comfort item and say that comfort is the driving force in cabin air quality.

I guess the group's concern here was that perhaps comfort is not being maintained through operating practice and not through design and that we

need to look at that, not just as a comfort function, but as a function of atmospheric contaminants.

I mentioned earlier that we felt hypoxia was not necessarily the effect being observed, but that there were perhaps other contaminants.

Again, to the group's knowledge, there had not been much work done in this area and perhaps, there should be in the near term since we are operating aircraft in this manner now.

Going further, we went into the area of crew training and coordination which has literally become fashionable and has gotten a lot of well-deserved attention both here and in the industry throughout the country and the world.

The group's feeling was that there is a difference in functional efficacy between the smaller aircraft, smaller transport aircraft or corporate aircraft, and the large wide body aircraft.

You have a difference in size, that is significant. You do not have the separation that you do in the wide body of large numbers of cabin crew. In a small aircraft, you do not even have a large crew.

Our view was that the emphasis on cockpit management, which is so prominent this morning, is at least in the case of wide bodies if not overall, really one of aircraft management. That should be the emphasis as all of us go running off down the path of developing or using cockpit management programs.

The group emphasized that it is normal for communications to break down or, shall we say, be less than normal during emergencies. But that the phenomenon should be minimized and can be minimized by cross education of the cabin and cockpit crews as to what their mutual duties are, what each is going to be doing, and to follow that up, maintaining communication during an emergency to provide each other with information that one or the other lacks. This should be, if not already, a strong element of crew training.

One other factor emphasized in terms of operational practice was the need for the captain of the aircraft to brief the cabin crew on the flight. It may not necessarily be a long, formal briefing, but some sense of briefing to develop a crew awareness.

We went into one interesting area; the corporate flight attendant is a group that's relatively small, but deserves emphasis here. They have on their

own, the corporate flight attendant group, developed their programs.

They have some advantages over the airline flight attendant group. They have smaller aircraft to deal with, smaller passenger loads, yet they have difficulties in the area of support. They cannot depend on a large organization to provide them with a lot of services which the airline flight attendants count upon.

They have to be self-sufficient. They have to be trained to be self-sufficient, particularly when they are going to foreign air fields, even smaller domestic air fields, where they literally are the only services provided both from the emergency and routine standpoint.

The group further noted that in the area of cabin safety, the FAA's carrier inspectors have not been, until recently, strongly involved in cabin safety. At present, the FAA requires 25 percent of their inspection activity to be oriented toward cabin operations; however, the goal has not been met, as the group felt, due to a perceived lack of seriousness in the program, and to the normal flying orientation of the inspectors.

Recent FAA actions have been taken to include cabin inspection reports in the cabin safety data bank and to begin detailed analysis of these reports. The group felt that this action on its own, without going any further for the time being, may produce a higher degree of interest on the part of the inspectors and cooperation. This would, in turn, benefit the quality of cabin safety provisions within and without the agency.

We went into another area, human factors and accident survival. The first topic of discussion here was water survival technology and problems, and the major emphasis for the group was the problems of flotation cushions and the relative quality of these cushions as a survival aid when compared to other existing or potential survival equipment.

In general, it was felt the cushion may not be worth consideration as a survival aid. Instead, emphasis should be given to development of easily used life vests, and I emphasize the words "easily used life-vests and flotation platforms" that can be used in aircraft not currently equipped with conventional water survival equipment.

Particular emphasis was laid on FAA regulatory requirements regarding water survival training and TSO equipment standards, the latter dating from

World War II. Operators and manufacturers appear to find little relation between the requirements and current needs.

In the case of one operator represented in the group, they must train for planned ditching, if we can get into a little jargon here, please bear with me, they must train for planned ditchings and they do train for unplanned water accidents.

The latter training is not required. In effect, the operator is having to do double duty: 1) to meet an outdated regulatory requirement and; 2) to meet the actual need.

Recent experience seems to indicate the unplanned water accident is the valid area for emphasis; however, this operator, as I said, remains saddled with the requirement dating from some 40 years ago.

Within the industry, this whole topic has not really been looked at --- we have had other things to look at. However, it is one of current discussion within the industry and one that we felt worth going through.

From the standpoint of corporate aircraft, the point was made that water survival equipment is often added to the corporate aircraft as an afterthought without regard for its location, its accessibility or its efficacy. Partially, this is due to the fact there is no guidance on what you should do with the equipment.

You have limitations to what the equipment is, but then you also have limitations on what you do when you put it in the cabin. Are there better places to put it? Are there worse places to put it? And this is something that could be approached by the industry.

In the area of accident injury prevention, there was a great deal of discussion on human injury tolerance and the equipment capabilities, with a distinction between the two. Very clearly, the group wanted to talk about the difference between establishing the damage tolerance to the aircraft crew and passenger seats versus the need to define the capability of the crew members and passengers themselves to withstand the accident deceleration forces.

Strong emphasis was put on the need for biomedical research into the tolerances of passengers, restrained only by lapbelts to deceleration.

To date, everything has emphasized full restraint systems, torso harnesses, crotch straps, lap belts, and the whole works. And from the manufacturers' standpoint that is not very useful, because that is not the seat the passenger sits in.

This is an area that certainly CAMI, if no other place, could work in.

The FAA's plans, announced more than a year ago, to examine accidents more closely with respect to the success of restraint systems have not reached implementation and should. They would be an adjunct to the biomedical research that I just mentioned.

In discussing the matter of passenger weight and size, the current values used in equipment design and even simply weight and balance, it was interesting to note that one of the Transport Canada representatives said that they have just recently completed a thorough field study which arrived at passenger size characteristics, which we in the room were all wondering -- were they current?

You know, there was a strong feeling that it was worth the FAA working together with Transport Canada to obtain these figures, look at them and evaluate what we're doing in terms of our design standards.

Two other topic areas fell in here -- the brace position and passenger preference for restraint systems. Regarding the brace position, the group observed that the old "grab ankles" technique is being deemphasized within the industry. The emphasis is changing to one of the goal of stabilizing the body in relation to the surrounding equipment in the most effective manner that the person can figure out, with some recommendations being given. The true concern is controlling the sudden release of energy rather than recommending a specific position.

This is what the group felt that we were working towards. In fact, in the case of the "grab ankles," it was felt that this was counterproductive and this was the reason that it was falling out of grace if not style.

In the area of passenger preference of restraint systems, the group felt that all of us were operating on assumptions of what airline passengers thought. But none of us really knew other than our own preferences when in an airline seat.

And they felt that the FAA or other parties should undertake some studies in the passenger population to see what they used, what they liked, what they do not like and what they truly do think.

It has been a long time since anybody made any studies regarding which way the seat was going to face and we all sort of harp back to those days and there has not been anything very firm since then.

In the area of aircraft fires, the group received a briefing on recent FAA and industry cooperation in testing of cabin fire extinguishers. The superiority of the Halon 1211 fire extinguisher in fire fighting was recognized, but it was clear the technical studies must be either conducted or reviewed and publicized concerning the relative toxicity of the Halon 1211 fire agent.

The group's concern here was that potentially a very good fire fighting tool may be rejected, or at least its adoption may be inhibited within the industry, by concern over toxicity which may not be merited, but in any event, is not known.

Again, that is something that could be done in the near term, and should be done because these fire extinguishers are on the threshold of being adopted throughout the industry and are superior in fire preventive capabilities, if we can demonstrate to the people that they are not harmful.

As part of the FAA's work in the cabin fire extinguisher area and coming back to the training area, the group felt it was very worthwhile emphasizing the need for the cabin crew to work as a team when fighting a fire, that one person does not pick up the bottle and take care of a cabin fire situation.

There are several functions that must be carried out, one of which is actually using the fire bottle and the crew training in this area must be refined. Some operators are already working on this area.

In the area of aircraft evacuation (this was another one where the matter of outdated regulations was felt to be a factor), there was concern voiced that future aircraft would not take advantage of research in emergency lighting among other topics, if current regulations relating to lighting location were not at least modified in some manner.

We are not talking about aircraft that are appearing in the next two or three years. We are talking about aircraft appearing within the next five to ten years. The question was to what degree are we saddling ourselves with inappropriate requirements? I think the group was interested in that, and it is an area of potential gain for the industry.

As a sort of recap here in the area of cabin safety, we got on the subject of location of emergency exits: What was the best means. We had a debate back and forth about tactile identification, visual identification, and aural identification. Someone came up with a summary which everyone liked. At this point, the well-trained flight attendant is the best way to get passengers to safe exits.

The well-trained flight attendant can overcome many of the problems associated with visual, aural, and other means of exit identification and with the nearly unpredictable postaccident circumstances.

Thank you.

DR. DILLE: The six human workshops to date have been funded by and under the executive direction of the FAA Office of Aviation Safety, the Director of that office, John R. Harrison. After taking this opportunity to sincerely thank our speakers, our workshop leaders, and each of the rest of you as participants in what we feel was a very successful meeting, I turn the platform over to Jack Harrison for the concluding remarks for this human factors workshop.

MR. HARRISON: Thank you, Bob. My purpose is not to make a speech, but merely to say thank you. We appreciate the efforts of the group leaders and this group for their industrious contributions to this subject. I would like to tell you what we plan to do from this point, this being the last of the workshop sessions.

We expect to put a program together within approximately 60 days. Thereafter, we will initiate the individual segments of the program.

With respect to the proceedings themselves, we will publish the proceedings in their entirety and, of course, in addition, we will mail copies of the transcript of these proceedings to each of the participants.



Eventually, you will receive a copy of the proceedings covering all of the workshops.

With respect to this proceeding, I think Bob mentioned that the record will be held open for 30 days and you can submit additional issues or recommendations for research and study.

We expect to have significant funding for this program and we anticipate that most of the research work will be carried out in industry or academia. Again, let me thank you for your contributions and in behalf of my office, the Office of Aviation Standards and the FAA, thanks again.

SUPPLEMENTARY MATERIALS SUBMITTED BY SPEAKERS AT THE FIFTH HUMAN FACTORS  
WORKSHOP ON AVIATION

June 30, 1981

AIR CARRIER OVERWATER HAZARDS - BACKGROUND AND SUMMARY:

Operating Environment: Over 200 U.S. air terminal airports have significant bodies of water in approach/departure areas. The majority of airline flights arrive, or depart, over these bodies of water. Water temperatures range from 32F to about 70F.

Water Accident Experience: Since the airlines began operating turbo-jet powered aircraft (1958), forty-three of these have been involved in water accidents, worldwide. Nineteen of these were U.S. operated. All occurred during approach/departure, many at night and/or in weather. The furthest distance from land was 30 miles (one accident). All of the others were within 15 miles of land. The maximum notice to aircraft occupants was about seven minutes.

Water accident Survivability: There were survivors in twenty-six of the forty-three accidents. In some cases there were survivors after very heavy impacts and vertical entry, factors which would mitigate against survival in land accidents.

FAA Regulatory Requirements: The governing regulations have not changed much since the 1930's, when one accident might involve about thirty persons. Much larger numbers are involved today. Under these regulations, the airlines are preparing for "planned ditchings" and many airline crew personnel have been conditioned to believe that overwater operation commences at least 50 miles from shore. FAA personnel have informed us that the "unofficial FAA working definition" of a water accident involves an event that occurs more than 400 miles from land and provides at least fifteen minutes notice to aircraft occupants. There has never, as noted above, been such an accident involving an airline jet aircraft. The last one fitting the definition was a L-1049, in the Atlantic, in 1962.

Under the regulations, airlines are required to have life rafts aboard when operating more than 50 miles from land. At this time, however, fifteen have exemptions allowing operation out to more than 160 miles without rafts.

When operating within 50 miles only individual floatation devices are required, either life vests or floatation cushions. Those carriers operating under exemptions are required to provide only life vests.

Overwater Emergency Equipment:

1. the "floatation cushion" is the only form of water survival equipment on the majority of aircraft. Users float on the back with the head in the water, thereby subject to drowning from wave action, or unconsciousness/drowning as a result of hypothermia. There are reasons to believe that some cushions lose

effective buoyancy after only minutes of use. Further, many airline passenger information cards depict users floating vertically, head out of water. FAA tests, in 1966, revealed that this position cannot be maintained.

2. Standard FAA-Approved life vests are derivatives of a 1930's design, the military "Mae West". This device was intended to be donned prior to overwater flight, by trained crew members. Several accidents, and many simulations, have demonstrated that most passengers (and many crewmembers) cannot locate, don and operate the device under actual emergency conditions, or in no-panic, full light, simulations. In one accident, according to the NTSB report, passengers were almost totally preoccupied with locating, unpacking and donning the vest over a period of about seven minutes.

3. The current life rafts are too heavy and bulky to be successfully launched under the most-probable accident conditions. But, they are also unsuitable for planned ditchings; over a twenty year period less than 50% of installed rafts were launched successfully, when time was available, and in some cases none were launched. In lieu of developing rafts which are suitable, the FAA cites deployment problems as part of the rationale for not having them aboard.

Crew Overwater Emergency Training: With rare exceptions, these are based on the "planned ditching" scenario. During the drills, time is available for vest donning, raft positioning at exits, etc. Some airlines provide a little training in unintentional water contacts, others pay lip service to it and some teach that all water accidents are planned accidents. The crews are not prepared to react to this most-likely accident.

Rescue Capability: There is none in the context of locating and recovering large groups of persons from offshore waters, within their anticipated life expectancy.

Environmental Hazards: In 32F to 50F waters, we can expect casualties within minutes of entry. Immersion effects will have rapid impact on children, elderly, those with heart/respiratory conditions. The physically handicapped and non-swimmers will drown quickly. Even the fit and competent will face drowning, given the nature of the individual floatation devices. In cool, or cold, water it will be a "race" between death from drowning, or from loss of body heat (hypothermia) In warmer waters, sharks are a definite threat. It will be another "race".

It is clear that large airline aircraft can be involved in water accidents. Accident experience shows that these will probably occur in offshore waters with little notice. The same experience shows that both equipment and training are unsuitable. There is therefore a probability of major casualties in a survivable accident. Persons who conduct "cost-benefit" studies might consider the costs of preventing these deaths prohibitive. We believe, however, that the true cost will be pennies per passenger flown and that the FAA, charged with providing the "highest possible degree of safety" should require immediate corrective actions.

Prepared By: Wayne E. Williams, Director, Institute for Survival Technology

BEHAVIORAL ENGINEERING LABORATORY

Department of Psychology  
Box 5095/Las Cruces, New Mexico 88003  
Telephone (505) 646-4716



A Program of Research on Human Factors in Aviation

---

Stanley N. Roscoe  
Behavioral Engineering Laboratory  
New Mexico State University

PROBLEM

Modern aircraft feature computer-aided communication, navigation, guidance, control, and display systems. Area navigation systems and control procedures have been implemented in a preliminary way and are being extended to provide vertical guidance, speed control, and energy management. Improved traffic control computers are being developed, a new microwave landing system (MLS) is being implemented, and a satellite global positioning system (GPS) and communication aids are waiting in orbit. These technological and operational advances will affect all types of flying; their benefits and demands will not be felt exclusively by the aeronautically sophisticated.

Predictably the situation just described involves complex changes in the roles of people and machines both on the ground and in the air. Understandably various elements of the aviation community are concerned about the long-standing human factors problems that are being elevated to critical levels and will surely get worse before they can be solved. However, before presenting a program of research on human factors in aviation, let us examine why such a program should be considered at all and what can reasonably be expected to result from its implementation.

There appear to be two principal reasons for the growing feeling of urgency in developing a program of research on human factors in aviation. The first concerns the changing roles of flight crews and air traffic controllers with increasing computer-based automation and the impact of these changes on the people themselves--not only on pilots and controllers but also on passengers and support personnel. The second is the growing recognition among responsible people that both airborne and ground instrumentation, including simulators and other training devices as well as displays, controls, and communication equipment, frequently fail to provide necessary and sufficient information in a suitable form for current operations and that this need not and should not be the case for the future.

#### Function Allocation to People and Machines

Whether on the ground or in the air, some functions can be handled better by computers than by pilots and controllers, but the converse is also true. Nevertheless, the best ways to take advantage of the capabilities of each are not always evident and generally not clearly resolvable on the basis of current scientific knowledge. Furthermore, how well each can handle any given function depends greatly on how performance of the function is designed into the system--how computers are programmed and how pilots and controllers are selected and trained and what types of displays and controls are provided to support their uniquely human abilities.

Other things being equal, as they seldom are, if people are to be most effective in complex system operations, they have to be kept busy. Humans are poor watch-keepers, or monitors, called on to perform only when something goes wrong or when the unexpected occurs. Computers, on the other hand, are excellent monitors and are capable of fast, accurate, and reliable responses in any situation that occurs predictably. The "Catch 22" is that the uniquely human capability to handle the unpredictable can be depended on only if the human is awake, alert, and ready to take effective action, and these conditions can be maintained only if the human is routinely involved and currently proficient.

#### Human Factors in Aviation System Design

The burden of human factors research in aviation is to provide a practical scientific basis for designing equipment and procedures and training and certification programs to optimize human performance of those functions assigned to pilots, controllers, and maintenance personnel. Whenever an airplane cockpit, a traffic control center, or an operational or maintenance procedure is designed, the designer has to make many decisions, whether consciously or otherwise, that will affect the performance of operational and/or maintenance personnel. Some relevant design principles have been established and embodied in minimum standards for certification, but these are generally not well stated, documented, or understood.

Human Factors in Aviation Training and Certification

Similar problems exist in the area of operator training, certification, and currency maintenance and assurance. Some principles of effective training and transfer of learning have been developed through research and operational experience. But once again these have not been well documented and are not well understood by many who are responsible for specifying the characteristics of training devices or for developing training programs. Clearly the major airlines have made the best use of advanced technology in training, but even here much improvement is possible and needed, and the benefits of their experience need to be passed along to the rest of the aviation community.

## APPROACH

How should a program of research on human factors in aviation be organized and implemented to assure timely availability of workable solutions for the problems just described?

As a first suggestion, the problems can be approached in either a horizontal or a vertical fashion, and each has its place. By the horizontal approach we mean the development and validation of general principles of design for human effectiveness--principles that can be applied across the board whenever an operator is called on to perform a certain class of functions or tasks. By the vertical approach we mean the application, testing, and validation of horizontally derived principles during the advanced development of specific systems and prior to their operational certification. While this may cost time and money up front, it will surely pay off later.

As a general rule, horizontally oriented research tends to be done by universities and by a few small contract research groups. In contrast, the time and energies of research personnel in government laboratories and industry tend to be consumed by projects of a more typically vertical nature. The research programs at the University of Illinois on principles of display frequency separation, flight path prediction, and visual time compression are representative of the former type. The cooperative FAA/NASA programs on terminal configured vehicles (TCV) and the cockpit display of traffic information (CDTI) are recent examples of the latter type.

Display and Control Design Principles

Recurring problems in instrument design stem from the fact that whenever any particular function has to be implemented the designer has to make a number of decisions; he may or may not be aware that he is making decisions, and very frequently he fails to consider that the same alternatives have been dealt with many times before over many other drawing boards. Few laboratory directors, project engineers, training managers, or pilots realize just how many important design

decisions are made in precisely this way. Nevertheless, this process has gone on and on throughout the history of aviation system development.

What are the sorts of decisions made over and over by different designers at their drawing boards? A few examples and some of the alternatives involved are listed below:

1. Size, scale factor, and sensitivity of a display
2. Direction of sensing: fly-to, fly-from, or frequency-separated
3. Visibility and reachability
4. Combinations of indications within a display
5. Display modes: alphanumeric, symbolic, pictorial
6. Arrangement of controls and displays within a panel or console
7. Feel of controls: damping, detents, feedback
8. Coding and function of switches, knobs, levers
9. Grouping of functionally related operations
10. Logic and coding of caution and warning indications

During the less than half-century since human factors engineering was recognized as at least a semiscientific discipline, countless horizontal and vertical research programs have dealt with such issues as those embodied in the list above. Nevertheless, different decisions have been made by different designers regarding similar applications of each of the items listed. Possibly because individual applications differ in subtle ways, the proper selection among design alternatives is not always evident even to the most experienced people in the field.

None of the required decisions would be particularly difficult to make if experts could agree on the correct choice among alternatives in each case or if there were available a sufficient body of objective data describing the consequences of any decision. It is a fact, however, that the experts do not agree. Some like the moving card, others like the moving pointer; some believe in "symbolic" others in "pictorial" displays, and so on. On the other hand, there is experimental evidence on many of these issues, but it is not complete and, in addition, lacks generality. When new problems arise that are somewhat different from the old ones that have been solved experimentally, it is not certain that the old solutions are applicable.

Solving each new problem or each new version of an old problem by experiment is simply not feasible. There is neither enough time, money, nor manpower to accomplish such a program. Nor is it satisfactory, in the absence of experimental evidence or unanimous opinion, to be confronted with the necessity for making what often appear to be arbitrary decisions. Often this necessity is avoided by authorizing development of several alternative versions of the same system in the hope that one will prove satisfactory. When this is done the designer knows in advance that a large proportion of his money is necessarily being wasted.



The hope that a largely horizontal program of research might ultimately reduce the designer's uncertainty appears to follow as a natural consequence of the present dilemma. A horizontal program, as a complement to existing vertical programs, carries with it the notion of generality of results, and this is what is needed. The horizontal approach implies in effect: let us not be totally diverted by the particular problems that arise from day-to-day, but let us consider the problem as a whole and attempt to arrive at general rules for displays and controls that can be applied successfully in any subsequent instance.

### Training and Transfer Principles

Human factors problems associated with the training, certification, and refreshment of pilots, controllers, and support personnel have much in common with those encountered in equipment and procedures design, but there are also notable differences. In common is the situation that much of what is known and can be stated as principles is not necessarily known to the people responsible for operational applications. In contrast, however, this is not so much a problem for research as it is a challenge to spread the word to managers, administrators, and individual operators, including instructional system developers and professional instructors.

For example, the potential effectiveness of flight simulators in pilot training and certification is well documented, and in the case of airline operations, widely and legally accepted. However, simulators do not command similar respect and use in general aviation, air taxi, and commuter operations. Admittedly there is less economic pressure to replace flight training in less expensive airplanes, but the factors contributing to the relatively ineffective use of simulators in primary and intermediate training phases are complicated and subtle. To be cost effective, simulators must save their operators money by costing less to own and operate than the flight time they replace.

Possibly because of the outstanding success of airlines in using complex and costly flight simulators for training, the belief is widely held that simulators have to look, feel, move, and smell like airplanes to be effective. In a subtle way the airlines have been caught in their own trap. To persuade their professional pilots to accept the complete substitution of simulators for airplanes in the training and certification process, they have emphasized the total fidelity of simulators to their counterpart airplanes. The pilots, in turn, have so embraced the notion that a simulator has to be a tethered airplane that they are now insisting on simulators of higher and higher apparent fidelity.

This circular sequence of events and positions appears to offer mixed blessings. Clearly the importance of certain types of simulator fidelity has been well established both through research and operational experience, and this conclusion is gaining wide acceptance.

Unfortunately it is also evident that efforts to achieve ultimate apparent fidelity of simulators can be counterproductive. Not only is the cost far out of line with any possible benefits, but also the training effectiveness of such devices can suffer. Research has shown that certain intentional departures from literal duplication of aircraft characteristics can make possible training strategies far more effective than those currently employed.

Evidence for these strong and, to some people, heretical statements can be found in research on augmented feedback in training, on unrealistically exaggerated response lags and instabilities, on intentionally reduced visual cues in contact flight training and elevated workloads creating larger than lifelike stresses analogous to swinging a leaded bat before stepping to the plate. Similarly the unwarranted emphasis on ultimate apparent fidelity tends to discourage development and imaginative use of simpler and more flexible and reliable part-task devices and computer-based teaching scenarios that can yield even more effective training at a greatly reduced cost.

Reasons for the current state of our aviation training technology are not hard to discover. While the Department of Defense has invested vast sums in training-research simulators, virtually all of the research has been of a vertical rather than a horizontal nature. Because transfer of training experiments are difficult to conduct and also very expensive, such experiments typically involve comparison of two, three, or four training conditions treated as qualitative factors because they are actually composites of quantitative factors too numerous and confounded to unravel and manipulate individually. This approach is essentially vertical in that total simulator configurations are developed and then comparatively evaluated.

Results of such comparisons lack generality of application because they reflect only the combined effects of particular sets of values of the many component variables individually important in simulator design and use. To get at the main effects and interactions, statistically speaking, of the many independent design and use variables, a different research strategy is called for, one that is essentially horizontal rather than vertical. Fortunately a research paradigm new to the aviation community, but long used in the chemical industry, has been advanced by Dr. Charles Simon.

The practicality of applying this innovative research strategy to human operator performance and training is no longer a matter for speculation. More than half a dozen experiments conducted at the University of Illinois have involved experimental designs and multiple regression analyses of the type advanced by Simon. Also such a design was employed successfully at NASA-Ames Research Center in a study of pilot judgment of projected touchdown points on simulated landing approaches by reference to computer-generated visual displays.

HUMAN FACTORS AND AVIATION SAFETY  
STANLEY N. ROSCOE

Even more directly applicable, a transfer of training experiment recently completed at New Mexico State University included five simulator design variables, one training variable, and three transfer-vehicle configurations. The experiment, completed in less than a month, involved only 80 trainees, 48 of whom received training in individually unique simulator configurations. The experiment yielded reliable and unbiased regression equations for the main effects and first-order interactions of the six experimental variables for each of the three transfer-vehicle configurations. The specific findings of this experiment, dealing with a simple lateral-steering task, have little direct application to aviation but demonstrate that meaningful multifactor transfer experiments can be conducted effectively and economically.

#### FRINGE BENEFITS

Benefits of an aviation research program are not limited to the application of research findings and technological advances, although these can be expected to be substantial. The functions of such a program are to educate as well as discover, and the production of scientists and engineers who specialize in solving human problems encountered in aviation system design, training, operation carries a high priority at this time; individuals formally trained and with research experience in these areas are in extremely short supply and are badly needed by the aviation community.

APPLICATION OF EPIDEMIOLOGIC CONCEPTS IN RESEARCH ON  
HUMAN FACTORS IN AVIATION

Dr. J. G. Daubs  
TWR Corporation  
173 Central Ave.  
Milton, MA 02186

Potential contributions of epidemiologic science to aviation

Comments submitted in response to:

5th HUMAN FACTORS WORKSHOP ON AVIATION:  
BIOMEDICAL AND BEHAVIORAL FACTORS IN AVIATION

Sponsored by the  
U. S. DEPARTMENT OF TRANSPORTATION  
Federal Aviation Administration

July 7-9, 1981

Mike Monroney Aeronautical Center  
Oklahoma City, Oklahoma

## INTRODUCTION

In recent years human factors researchers have witnessed with delight the growing demands for their expertise and services. These calls have come from academia, government, and private industry alike. Even the public at large has seemingly recognized the need for science to not ignore the human factor. The present workshop is but part of a larger reaction to these stimulating developments. The U.S. General Accounting Office ( Comptroller General) Report (CED-80-66) for example, encourages the FAA to reinforce and expand attention to human factors. Yet, more careful scrutiny of the non-specialist's concepts of human factors often reveals that new dimensions have been added to the expectations of human factors research. These new dimensions extend well beyond the bounds of "Knobology", "Boxology", and "Simulology", past clinical and experimental biomedicine and behavioral science on into the region of observational epidemiology. Human factors criteria have been essential to epidemiologic studies in occupational medicine and public health (1). In turn, human factors research may be strengthened through application of epidemiologic principles. The purpose of the following remarks is to present some of the recent thoughts from modern medical research and contemporary epidemiology and suggest that these conceptualizations may be useful in developing a more systematic and rigorous approach to human factors research in aviation.

## EPIDEMIOLOGY

In that few epidemiologists are engaged in human factors activities (less than 2% of the Human Factors Society membership are from medicine(2)) it seems appropriate to offer a brief overview of this branch of science. The term itself is derived from epi(upon), demos(people), and ology( thought). In its broadest sense it is the study of conditions that occur upon humans. Thus like "human factors" the term "epidemiology" is open to many interpretations. Today, epidemiologists usually define the discipline as the science (more than just the study) of the occurrence of morbidity ( and by implication, of health, safety, function, performance, etc.) in man. Traditionally, epidemiologists are clinicians who study health in populations or groups of people. One essential difference between epidemiology and clinical practice is that the former is concerned with groups of people ( patients and non-patients) in their natural environment, whereas the latter focuses upon the individual(patient) more or less isolated from his environment.

Epidemiologic activities can be reduce to two general categories; descriptive and inferential, with inferential work being either particularistic ( specific program, planning, or policy studies) or scientific ( discovery of the natural laws governing health). In common usage the term epidemiology can refer to that body of knowledge or collection of information about a health condition, the method of study using observation of groups, or the science of the determinants and origins of health ( or illness).

Six areas have been identified (3) in which epidemiologists contribute to knowledge of health and safety and in which they aid in human health and safety decision making:

ETIOLOGY	Identifying and quantifying causal factors or risk indicators.
EFFICACY	Establishing the degree to which health and safety practices are either beneficial, useless, or harmful.
EFFECTIVENESS	Measuring the level to which an efficacious practice actually benefits a defined group.
EFFICIENCY	Measuring how much effectiveness can be achieved for a given expenditure of resources.
EVALUATION	Assessing the extent to which a stated goal, objective or standard is actually reached as the result of specific health or safety practices.
EDUCATION	Introducing practitioners, administrators, and policy makers to the epidemiological perspective, and to the value of applying quantitative science to health and safety problems.

From the above definition and description of epidemiologic work the human factors specialist can surely recognize many overlapping areas of interest. This is especially true if we consider the expanding horizons of the human factors field.

## EPISTEMOLOGY

Scientific research activities can be said to operate on an epistemological scale extending from the molecular or particle level on one end to the world or universe level on the other end. Most biological and medical researchers operate toward the reductionist end of the spectrum and search for knowledge about the mechanisms of health or disease. Epidemiologists work near the opposite end- in the holistic portion - of the epistemological scale; they search for knowledge of the determinants of health or disease. The fundamental issue confronting medical research today is deciding on the role and priorities

of these two approaches to health knowledge and control(4).

Among the public there is widespread belief that through basic medical research we have stamped out the great disease killers of the past. It is true that there has been a linear decline in most infectious diseases over the last century, but the evidence suggests this improvement in human health has been related to better socio-economic conditions, not the result of reductionist medical research. In fact the dominance of the mechanistic approach to health research since the 17th century has been said to have led us to overlook the importance of "smoking, refinement of food, and lack of exercise is respiratory, intestinal, and cardiovascular disease."(4)

Our objective here, however, is not to compare the relative merits of the two approaches for they are complementary. Both are sources of enlightenment; each has it's own class of problems for which it is more likely to produce rewarding results. The two epistemological approaches are important in the context of human factors studies primarily because each has spawned research methodologies that to the uninitiated appear similar, yet are so strikingly different that failure to recognize these distinctions can lead the unwary investigator to false conclusions. As Kenneth Boulding said in his recent presidential lecture at the annual meeting of the American Association for the Advancement of Science, (5)

"The uncritical transfer of statistical techniques which are entirely appropriate in some epistemological fields, into fields in which they are quite inappropriate, has been the source of a great deal of wasted scientific effort."

Methodological differences between the two approaches are many. For example, one employs the well known experimental method, the other often uses the more complex and less well known non-experimental method. One assesses results by statistical inference procedures, the other demands the causal inference process ( It should be stressed that the basic principles governing the process of causal inference are NOT the same as those of statistical inference.(6)) Acceptance criteria for the one are usually two-sided arbitrary "p" values, for the other, rational standards are set based on existing knowledge and pragmatic projected outcomes. One approach emphasises sample quantity; the other subject quality. As mentioned before, both approaches are useful, the difficulty arises when the experimental techniques are misapplied to inappropriate data.

## CONCEPTUAL BARRIERS

It has been recognized that scientific progress has frequently been held back by inadequate problem conceptualization. The evidence was already at hand but the problem was obscured by intellectual fallacies. As medical research advanced these obstacles had to be overcome. Feinstein (7) has identified five common beliefs that have acted as major conceptual barriers to the progress of clinical science:

1. In motivation, the clinician believes that the main incentive for scientific research is to discover the cause of natural phenomena and that phenomena whose causes are unknown cannot be properly managed;
2. In reasoning, the clinician believes that his intellectual organization of clinical observations is rationally amorphous -that his thinking has too many intricate and unquantified elements to be expressed in the mathematical structures used for other types of scientific analysis;
3. In observation, the clinician believes that his descriptions of symptoms and signs cannot be scientifically precise because they often contain nouns, adjectives, verbs, and adverbs rather than the numerical dimensions of measurement;
4. In correlation, the clinician believes he finds a constant association between the abnormal structures and abnormal functions that occur in human illness; and
5. In classification, the clinician believes that he adequately identifies human illness by categorizing sick people with diagnostic names that represent the morphologic and laboratory abnormalities of disease.

Feinstein proclaims that

"Each of these beliefs is widely disseminated, long established, and seldom questioned; each has achieved the secure status of tradition; and each is either inappropriate, obsolete, or mistaken."

Analogous misconceptions may currently serve as deterrents to the growth of human factors research.

## STRATEGIES AND TACTICS

As human factors investigators delve further into non-experimental research they may benefit from some of the strategies and tactics used by epidemiologists. Initially in epidemiologic work it was necessary to improve study designs in the areas of homogeneity, taxonomy, and nosography. A similar effort might be productive in human factors research.

Inasmuch as the predominant study format for epidemiologic research is the non-experimental design, epidemiologists have had to develop means of avoiding, removing, or controlling for bias and confounding. Indeed the major issues in epidemiologic research are bias and confounding. These are complex matters and cannot be discussed within the constraints of this brief paper. The main strategies involve restriction and stratification maneuvers. For those more familiar with observational research figure 1 and table 1 offer some insight into the epidemiologic approach and the causal assessment process.



## RESEARCH OBJECTIVES

Judging from much of the material presented the objective of human factors research might be construed as the search for "statistical significance." In the early stages of investigation, prior to the development of biologically plausible hypotheses such qualitative objectives would be acceptable. The main thrust of epidemiologic work takes place in the quantitative stage. Here the objectives are effect estimation, risk factor identification, impact assessment and can involve decision analysis and cost-benefit studies that yield results usable by planners and policy makers.

Many of the human factors data appear to be amenable to these advanced analytic methods. Many of the existing data not in usable form could also be cleansed and interpreted by epidemiologic procedures. It thus appears that there is an opportunity to enhance our human factors knowledge by altering our research objectives.

## CONCLUSIONS

This short commentary is intended to encourage expansion of human factors research through the application of epidemiologic science. The chief short-term gain would be through reassessment of existing reports and use of existing databanks where the data are compatible with effect, impact, and decision level analysis. By-products of this approach would be identification of data deficiencies, recognition of additional research opportunities, and establishment of research priorities.

## REFERENCES

1. Rey, P. Ergonomic Criteria Necessary to Epidemiologic Studies in Industrial Medicine and Public Health. Ergonomics 22(6):661, June, 1979.
2. Human Factors Society Directory and Yearbook 1981, p145.
3. White, Kerr L. Contemporary Epidemiology, International J. Epidemiology 3:295-303, 1974.
4. McKeown, T. The Direction of Medical Research, The Lancet No. 8155, Vol II for 1979, p1281-1284, Sat. 15Dec. 1979.
5. Boulding, K.E. Science: Our Common Heritage, Science 207(4433):831-836, 1980.
6. Susser, Mervyn. Judgement and Causal Inference Criteria in Epidemiologic Studies, Amer. J. Epidemiology 105:1-15, 1977.
7. Feinstein, A.R. Clinical Judgment, Baltimore, Williams and Wilkins, 1967.

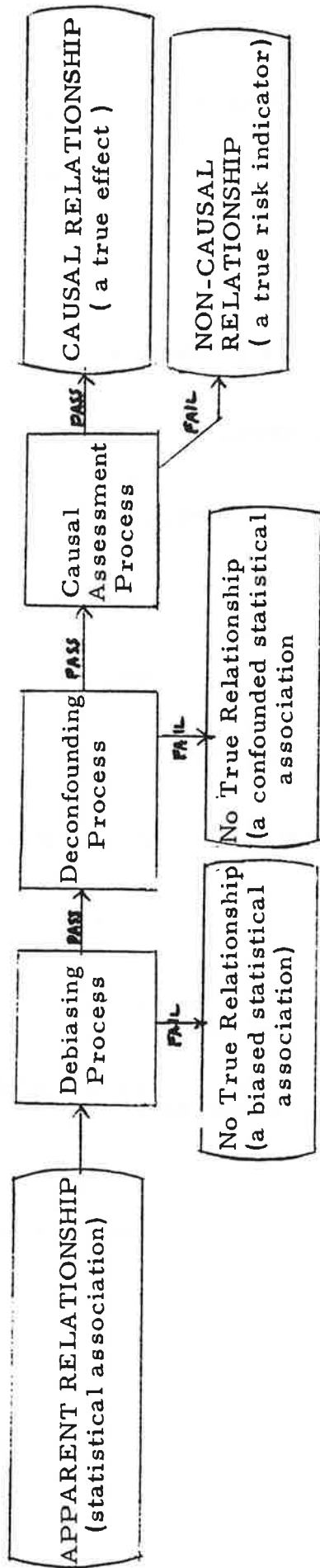

Figure 1. FLOW DIAGRAM FOR EPIDEMIOLOGIC EVALUATION OF AN APPARENT ASSOCIATION.

Table 1 . ELEMENTS OF THE CAUSAL ASSESSMENT PROCESS

---

---

- 1- Temporal order: cause precedes effect.
  - 2- Clinical trial/experiment : removal of cause prevents effect.
  - 3- Gradient of effect : dose-response relationship.
  - 4- Magnitude of effect : strong effect more convincing.
  - 5- Replicability : effect occurs in other similar circumstances.
  - 6- Clinical coherence : does not conflict with "known" natural history of disease.
  - 7- Biological plausibility : does not disagree with "known" biological mechanisms.
  - 8- Sociological credibility : Not at variance with "known" societal events.
  - 9- Clinical analogy : similar causes produce similar effects.
  - 10- Simultaneous specificity : both cause and effect limited to specific circumstances.
  - 11- Specificity of primary effect: effect under study is stronger than other effects produced by the same cause.
-

ADDITIONAL COMMENTS PRESENTED DURING WORKSHOP C

COMMENTS OF BERTIL WERJEFELT, PRESIDENT, XENEX CORPORATION FOR THE RECORD  
ON FIFTH HUMAN FACTORS WORKSHOP ON AVIATION, JULY 7-9, 1981 - WORKSHOP C:  
CABIN SAFETY - SMOKE AND FIRE FACTORS: TOXICITY, HUMAN LIMITS AND PROTECTION.

\* \* \* \*

The discussions and presentations on the use of Halon 1211 were certainly an encouraging step forward in aviation safety. However, current practices to suppress fires could be further improved. The recent disaster in Riyadh is ample testimony to this fact. Information available at this time indicates that toxic fumes from an inaccessible cargo fire caused the 301 fatalities. In order to have a meaningful fire extinguishing system, it is imperative that all possible sources of fire and toxic fume generation be accessible, either with portable extinguishers or permanent installations. Recognizing that permanent installations in the fuselage may be objected to from a weight standpoint, it may be advisable to provide more hatches in the cabin floor in order to have easy access to all cargo areas. By so doing, the use of the portable extinguishers could be maximized. Obviously caution must be exercised when opening hatches. Improved fire fighting training for flight attendant personnel would also enhance safety.

The toxicity of fire suppressants as well as the toxicity of the products of combustion warrant that emergency protective breathing equipment be provided for all occupants on board aircraft. Presently, emergency breathing equipment for toxic fume protection is only provided for cockpit crews. In some cases, flight attendants are provided a portable emergency breathing device which incorporates a smoke hood. This device, we are told, has a fifteen minute duration of breathable air. The installed weight is between 4½ and 5 pounds per unit. The duration of breathable air or oxygen available to the cockpit

crew in the event of a smoke or fire emergency is not well defined, but can be interpreted to be 2 hours based on FAR 121.333. Supplementary oxygen supply (duration) varies from airline to airline. Some airlines provide from 4 to 8 hours of supplemental oxygen (@ 14,000 ft.) for each flight deck crew member. This equates to a ½ to 1 hour pure oxygen supply per crewmember. FAR 121.337 "Protective breathing equipment for the flight crew" implies a 15 minute supply (300 liters STPD of oxygen per crewmember). Although the law is confusing as it concerns the actual minimum quantity of breathable air or oxygen that would be available to the flight crewmembers for toxic fume protection, it goes without saying that the longer one can sustain life in such emergencies, the better it is - especially if the extended duration does not entail added economic penalties. We are informed that the weight penalty associated with current cockpit crew emergency breathing equipment is at least 10 pounds per crewmember. This translates to a 15 to 20 minute protection against toxic fumes.

It seems that the justification for providing emergency breathing equipment for toxic fume protection for the crew, but not the passengers, is based on the philosophy that no one will survive unless the pilots do. However, it has been repeatedly demonstrated that a large number of fatalities involving seemingly survivable accidents are attributed to asphyxiation prior to or after landing. In other words, the aircraft lands intact but the passengers are asphyxiated. Although final reports have not yet been made concerning several recent disasters, it is believed that in excess of 600 people have been asphyxiated during the last 24 months, mostly on american made aircraft. In perspective, this is a staggering figure. In terms of loss of life due to asphyxiation, the aviation industry is confronted with the equivalent of an MGM disaster every few months.

In the MGM disaster 84 fatalities were recorded, 68 of which were unquestionably attributed to asphyxiation. (These victims showed no visible signs of physical trauma.)

The concept of providing toxic fume protection for crewmembers only is unquestionably outdated and contrary to available data and evidence which suggests that protection should be provided non-discriminately to all occupants.

It is not so that industry or the FAA do not recognize that there are problems. It seems, however, that the absence of an acceptable solution has posed a continuous deterrent to providing any toxic fume protective breathing equipment whatsoever for the passengers.

Two principal factors to consider when implementing any new safety system designed for use by the public are: A. The meaningful safety value of same and B. Educating the public to its use. Additionally, of course, there are moral, legal and financial ramifications.

Several years ago the FAA proposed that industry provide protective smoke hoods for passenger use. Industry objected on two principal grounds: The smoke hood would not provide meaningful safety value. In addition, considerable difficulty was anticipated in educating the public to its use.

Some of the products of combustion encountered in aircraft fires are extremely toxic. The fumes (hydrogen cyanide, for instance) can render victims unconscious in a matter of seconds. This is perhaps the most formidable consideration when addressing this problem. With such highly toxic components, that affect people in a few seconds, the fact that aircraft doors can be opened, for ventilation and smoke evacuation purposes, does not necessarily pose a meaningful safety value, given the time required to descend, depressurize and open the doors.



In addition to the protective breathing equipment, which is mandatorily provided for the cockpit crews, the cockpits are ventilated with fresh air at a rate which, in many cases, is 10 to 20 times higher than the rest of the interior aircraft. This high fresh air ventilation rate serves to further diminish the adverse affects of toxic fumes from a physiological standpoint as well as enhancing pilot visibility. The net effects are: smoke or toxic fumes emanating from other areas are essentially blocked from entering the cockpit (so long as cockpit door is closed) or, in the case of a cockpit fire, the smoke emanating from such a fire will be vented directly into the passenger compartment, where the passengers have no protection whatsoever from the toxic fumes!

Aircraft fires are of two principal categories - in flight and post crash. Meaningful safety devices for toxic fume protection should, of course, address both circumstances.

One of the objections voiced by industry to the smoke hood, proposed by the FAA, related to the difficulty in donning the device. Although there is some merit to this philosophy, it would seem that a smoke hood is better than no protection at all. However, it should also be pointed out that, in many cases the smoke hood would be relatively useless considering the practical aspects of aircraft fires. I.e. the first signs of a fire are usually manifested by smoke in the cabin. Thus, donning the mask would also entail breathing contaminated air trapped in the smoke hood.

The smoke hood was also objected to on the grounds that finding and donning the smoke hood would delay evacuation in the event of a post crash fire. There may also be some merit to this philosophy.

It is now approximately two decades since the toxic fume and asphyxiation problems were brought to the attention of government, industry and the public in the form of asphyxiation fatalities from seemingly survivable accidents. The absence of passenger safety equipment for toxic fume protection is now being brought into the legal arena. Recently, a \$62 million law suit was filed against two operators and one manufacturer seeking compensation for two lives lost in the apparently survivable Riyadh disaster (cause of death - asphyxiation).

The increasing use of combustible fluids as means of highjacking airliners is also focusing attention on passenger emergency breathing equipment as well as, of course, fire extinguishing equipment (Halon 1211).

There are viable solutions at hand which have been proposed by Xenex Corporation for which Xenex has patents pending. In further elaborating on this subject, I want to stress that while it is not my intention to use this forum to promote a specific proprietary product or system, I would consider it a disservice to members of this forum and the interest of public safety not at least to disclose that there are now inexpensive and effective remedies available from private industry.

In brief and simple terms, as explained to many of the participants at the conference, the Xenex Portable Emergency Life Support (PELS) Systems utilize the existing pneumatic air sources on board the aircraft as a source of fresh uncontaminated air. In one of the preferred embodiments, the ducted fresh air is diverted to the passenger service units and appropriately connected by means of a hose and air bladder to the existing oxygen masks. This provides the user a continuous uncontaminated fresh air source so long as the unit is connected to the supply source, in other words, several hours of breathable air if this

is necessary. The unit can be disconnected from its supply source thus providing a portable supply of air by means of the air bladder which can also function as a rebreathing bag. The portable supply is, within present design parameters, sufficient for 2½ to 8 minutes depending on individual requirements. Reconnecting the PELS unit to the supply source will rejuvenate the portable air supply in approximately 20 seconds, while simultaneously providing breathable air to the user.

As we all know, safety in aviation is in many respects based on redundancy systems. Therefore, (as it concerns the Xenex systems) in the event a compressor should fail, for instance, from a burned out bearing, which may, in fact, introduce undesirable and toxic fumes into the duct system, one would, of course, use another compressor as a supply source. In the event of complete engine failure in conjunction with the presence of smoke or toxic fumes, it would be desirable to have a connection from the ram air duct(s) so that clean ram air can be introduced into the system. The capability of providing ram air into the cabin is useful not only from a standpoint of providing breathable air in the event of engine or compressor failure, it also serves to enhance the removal of toxic fumes, as well as to maintain cabin pressure and temperature, in the event of failure of the air conditioning packs. By way of example, the pressure increase due to ram effect is approximately 50% over the static ambient at normal cruise speeds. This means, descending to 18,000 ft., where the static ambient pressure is approximately half of that at sea level, would provide approximately normal pressurization of 11 psia. The increased fuel burn at lower altitudes would make this a desirable feature, in that higher altitudes can be maintained, in the absence of functioning pressurization equipment.

By using ram air the need to open cabin doors for the removal of toxic fumes may also be obviated. Another side benefit of the use of ram air is the concomitant reduction in the use of bleed or compressed air when operating within flight altitudes where ram air is useful for pressurization purposes.

The previously mentioned weight penalties of approximately 10 pounds per cockpit crewmember to maintain 15-20 minutes of toxic fume protection, is in sharp contrast to the weight penalty associated with the Xenex PELS System which is on the order of only one-half pound (in many cases, less) per passenger seat, for several hours of breathable air, plus the portable feature.

Recent cost figures, relating fuel penalty to the carriage of superfluous weight on board aircraft, indicates that the cost per pound for a 747 operating 3,000 hours a year, is on the order of \$45 to \$50 per pound per year. Relating this cost to the current equipment required to provide toxic fume protection for the cockpit crew, we find the cost to be between \$450 to \$500 per year per crew seat. The cost of the Xenex PELS, assuming an average trip of 3 hours, based on average load factors of 60%, is on the order of 4½¢ per ticketed passenger!! On a per seat per year basis, it is 1/20th of cost of the cockpit crew system. The cost of equipment itself, considering shelf life of the equipment of 3-5 years, would add a fraction to the above cost of 4½¢.

On a ticket valued at hundreds of dollars, absorbing an additional cost of 5¢ for the purpose of safety and saving lives would certainly appear to be a prudent investment on the part of the air traveler as well as the airline. Obviously, there are no longer any valid economic deterrents against providing meaningful toxic fume protection for all occupants on board aircraft.

In an effort to ease and minimize the burden on industry, a Xenex PELS unit, suitable to be connected to the fresh air (gasper) outlets will also be available. This unit requires positive action on the part of the user for activation whereas, the other PELS unit previously described is a passive system, merely requiring the donning of the mask when it is presented.

The major objections previously voiced by industry vis-a-vis the smoke hood, i.e. meaningful safety value and delay in evacuation, are effectively remedied with the Xenex PELS System. A practical example of this, as it concerns, for instance, the evacuation of aircraft, would be to deploy the emergency breathing equipment, and if the passengers find need to use it in the course of evacuation, then they need merely breath from the nearest available unit. Current regulations require that emergency evacuation of aircraft be accomplished within 90 seconds. The 2½ to 8 minute portable air supply of the Xenex systems provides more than adequately for this implied requirement for portable protective breathing equipment in the course of evacuation.

In closing my comments on this issue, I believe you will agree it is blatantly apparent to everybody that: A. there is a long overdue need for emergency breathing equipment for all occupants on board aircraft; B. There are viable solutions (both technically and economically) available from private industry that can be implemented essentially immediately; C. Previously, the greatest deterrent, for an effective improvement in this area of aviation safety, was the cohesive will of all parties concerned to affect such an improvement, within the state of the art at the time. - It is impossible to perceive that this deterrent still exists.

Conclusively, although there are other parallel issues, relating to smoke and fire safety, deservant of utmost attention and resolve (some of which may await ultimate resolution for many years); safety improvements concerning asphyxiation hazards must be implemented in the immediate future.

I appreciate the opportunity to present my views on these serious issues and trust that they are of meaningful value to the members of this forum, the traveling public, FAA and industry.

\* \* \* \*

BIBLIOGRAPHY AND FIGURES FROM DR. JOSEPH TUCKER'S PRESENTATION,  
JULY 7, 1981

## Bibliography

1. Booze, C.J. The Morbidity Experience of Air Traffic Control Personnel, 1967-1977, FAA-AM-78-21, FAA Office of Aviation Medicine, Washington, D.C. April 1978.
2. Buckley, E. P., House, K and Hood, R. "Development of a Performance Criterion for Air Traffic Control Personnel Research Through Air Traffic Control Simulation", FAA-RD-78-71, FAA Systems Research and Development Service, Washington, D.C. July 1978.
3. Collins, W. E., Boone, J. O., and VanDeventer, A. D., EDS; "The Selection of Air Traffic Control Specialists: I. History and Review of Contributions by the Civil Aeromedical Institute", FAA-AM-80-7, FAA Office of Aviation Medicine, Washington, D.C., June 1980.
4. Donoher, J. W. "Human Error in ATC Systems Operations" Human Factors Vol. 22, No. 5, October 1980, pp. 535-546.
5. Finkelman, J. M. and Kirschner, C. "An Information-Processing Interpretation of Air Traffic Control Stress", Human Factors Vol. 22, No. 5, October 1980 pp. 561-568.
6. Guba, E. G. "Criteria for Assessing the Trustworthiness of Naturalistic Inquiries" Educational Communication and Technology, Vol. 29, No. 2 Summer 1981, pp. 75-92.
7. Hopkin, V.D. "The Measurement of the Air Traffic Controller" Human Factors Vol. 22, No. 5, October 1980, pp. 547-560.
8. James, L. R. Hater, L. J. Shanokon, J.W. Brini, J.R. Jones, D.B. and Sells, S.B. "Identification of Received Environmental Factors Associated with Student Adjustment, Laboratory Performance and Satisfaction in the Air Traffic Control Specialist Training Program", Institute of Behavioral Research, Texas Christian University, Fort Worth, Texas June 1980.
9. Kinney, G. C., Spahn, M. J. and Amoto, R. R. "The Human Element in Air Traffic Control: Observations and Analyses of the Performance of Controllers and Supervisors in Providing ATC Separation Services" MTR-7655, The MITRE Corporation, McLean, Va., December, 1977.
10. Pickrel, E. W. "A Job Simulation Approach to Selection Tests" Fourth International Symposium on Educational Testing, University of Leyden, The Netherlands, June 1980.
11. Pickrel, E.W. "Performance Standards for Pass-Fail Determinations In The National Air Traffic Flight Service Station Training Program." FAA-AM-79-18, FAA Office of Aviation Medicine, Washington, D.C. July 1979.
12. Smith, R. C., "Stress, Anxiety and The Air Traffic Control Specialist: Some Conclusions from a Decade of Research, FAA-AM-80-14, FAA Office of Aviation Medicine, Washington, D.C., September 1980.



13. Thackray, R. J. and Touchstone, R. M. "The Effect of Age on Complex Monitoring Performance, Laboratory Note Aviation Psychology Laboratory, FAA Civil Aeromedical Institute, Oklahoma City, Oklahoma.
14. Thackray, R. J. "Boredom and Monotony as a Consequence of Automation: A Consideration of the Evidence Relating Boredom and Monotony To Stress " FAA-AM-80-1, FAA Office of Aviation Medicine, February, 1980
15. Thackray, R. J. and Touchstone, R. M., "An Exploratory Investigation of Various Assessment Instruments as Correlates of Complex Visual Monitoring Performance." FAA-AM-80-17, FAA Office of Aviation Medicine, Washington, D.C. October 1980.
16. Thackray, R. I. "The Effect of Age on the Ability to Sustain Attention During Performance of a Simulated Radar Task" Research Task, Bimonthly Report, Task No.: AM-C-81-PSY-84, Aviation Psychology Laboratory, FAA Civil Aeromedical Institute, Oklahoma City, Oklahoma, April 1981.
17. Report, Institute of Social Research, University of Michigan, sponsored by The National Institute for Occupational Safety and Health, 1975.

Joseph A. Tucker  
Center for Educational Technology  
Catholic University of America  
Washington, D.C.

# Optional Retirement - Retirement Age

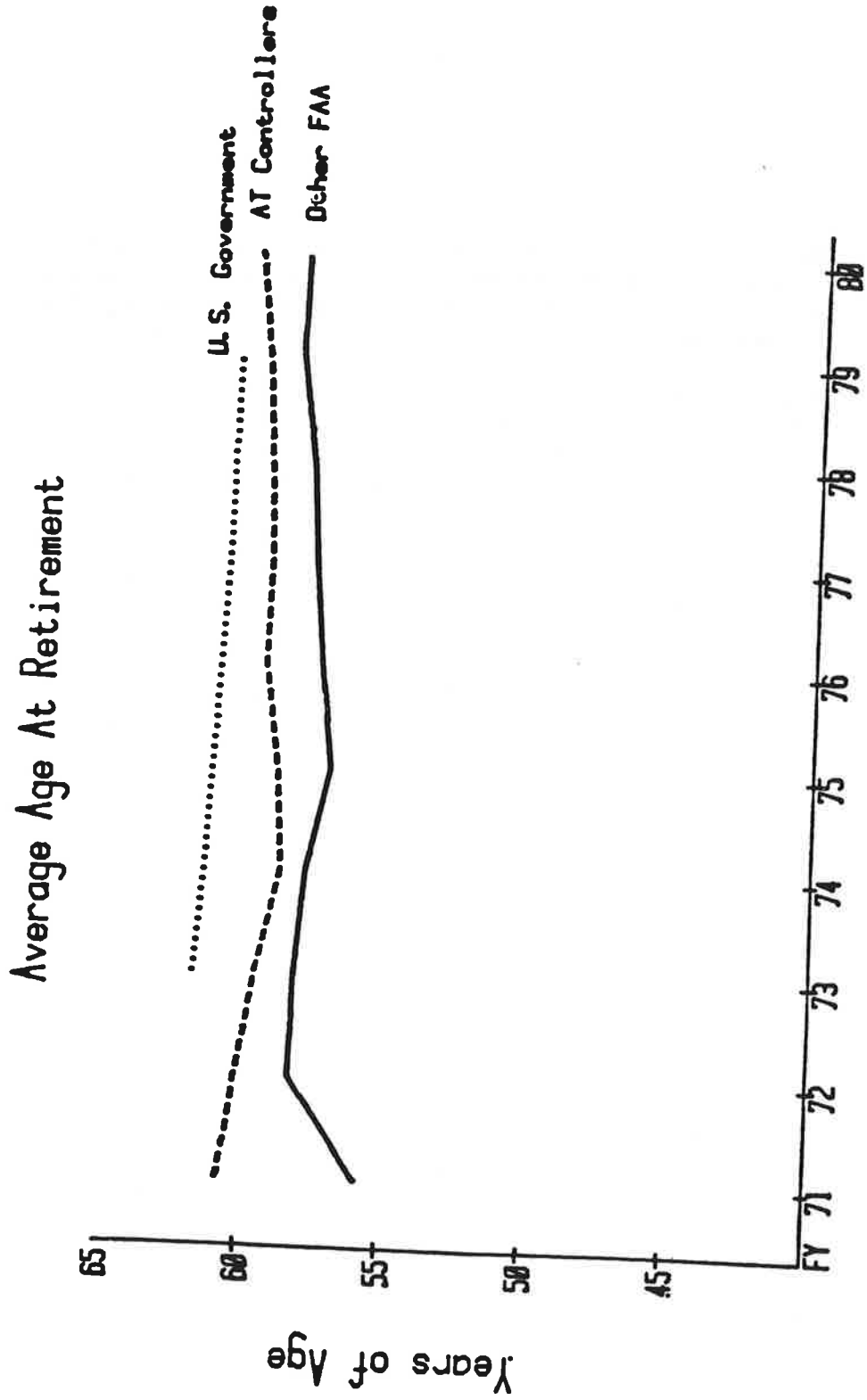

ADDITIONAL MATERIAL - TUCKER

# Optional Retirees - Length of Service

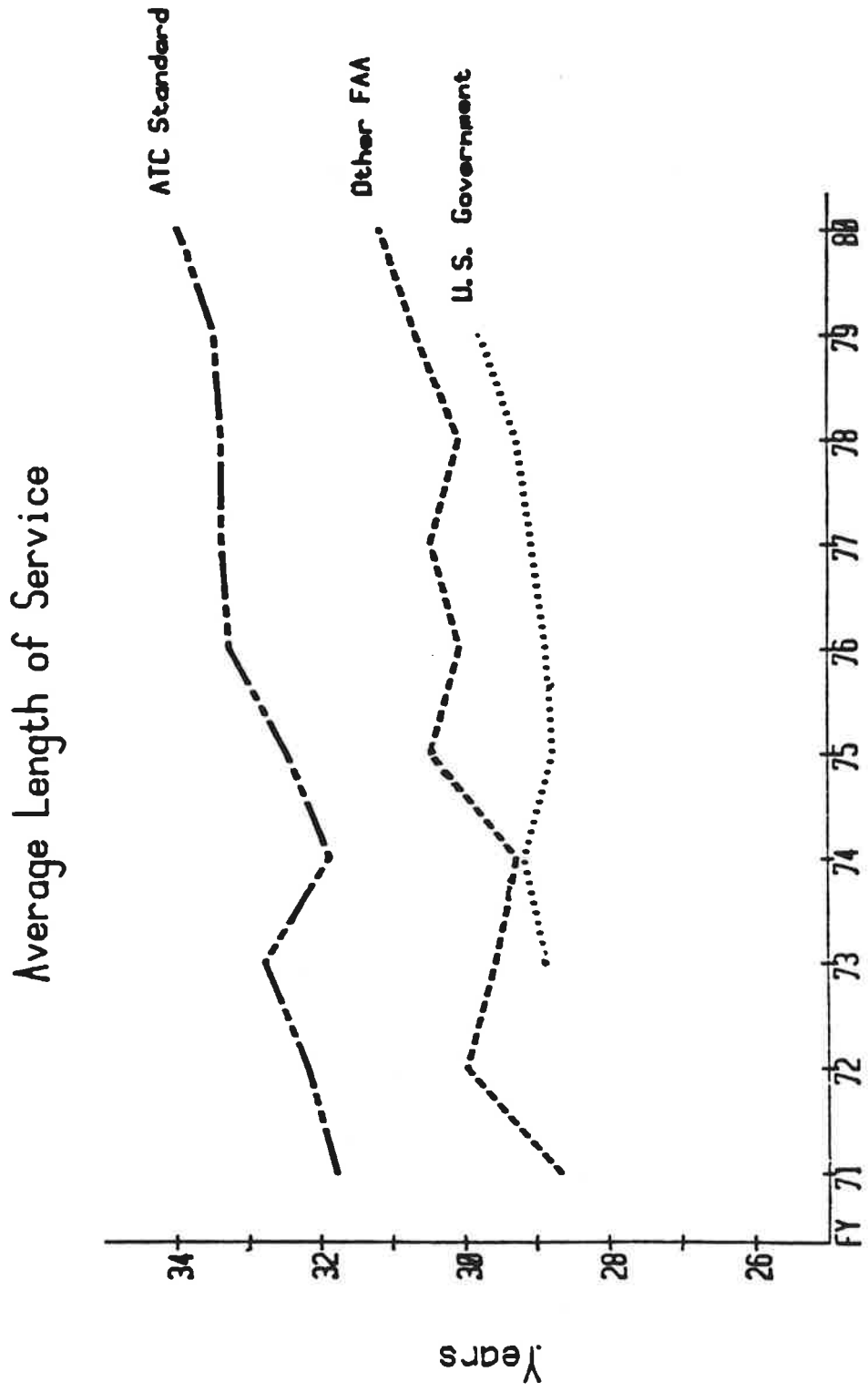

ADDITIONAL MATERIAL - TUCKER

QUESTIONNAIRES DISTRIBUTED IN WORKSHOP A, BIOMEDICAL AND BEHAVIORAL  
FACTORS IN PILOT OPERATIONS

IDENTIFICATION OF HUMAN FACTORS ISSUES IN AVIATION:  
BIOMEDICAL AND BEHAVIORAL FACTORS

I. TITLE OF ISSUE OR QUESTION:

Skill maintenance: pilot proficiency

II. SUMMARY OF ISSUE OR QUESTION:

Identify problem areas and make recommendations for the maintenance of pilot proficiency.

III. RATE PRIORITY OF RESEARCH ON THIS ISSUE AS IT RELATES TO AVIATION SAFETY.

/-----X-----/-----/-----/-----/-----/  
EXTREMELY HIGH      MODERATE      LOW      EXTREMELY LOW  
HIGH

IV. SUPPLEMENTARY INFORMATION.

A. EVIDENCE FOR IMPORTANCE OF ISSUES:

1. Number of aircraft accident, where pilots are in situations beyond their skills at that moment.
2. Increased information load pilots are required to process more today than before.
3. Variance of pilot's skills and aircraft types in general aviation.

B. FUTURE RESEARCH PROJECTS NEEDED REGARDING THIS ISSUE:

1. Effects of automated flight, increased information load on manual flying skills.
2. Evaluation of continuing pilot education, including standardization of R.F.R.
3. Evaluation of 6 hours, 6 approaches per six month regulation.
4. Development of ongoing pilot attitude training and assessment.

C. APPLICATION OF FINDINGS - SAFETY, EFFICIENCY, AND/OR COST BENEFITS EXPECTED FROM FUTURE RESEARCH ON THIS ISSUE:

Safety benefits are obvious; efficiency and cost benefits include not only fewer accidents, but reduced training costs: higher volume.

D. REFERENCES:

NTSB accident reports

E. (OPTIONAL) PARTICIPANT NAME: Fred C. Hyman

IDENTIFICATION OF HUMAN FACTORS ISSUES IN AVIATION;  
BIOMEDICAL AND BEHAVIORAL FACTORS

I. TITLE OF ISSUE OR QUESTION:

Investigation of the human factors involved in the introduction of cathode ray tube displays in airline cockpits.

II. SUMMARY OF ISSUE OR QUESTION:

More information is needed on numerous pilot/display interface questions such as what information to display, when, what form, priority of various information, what should be automatically displayed, what manually called up, etc.

III. RATE PRIORITY OF RESEARCH ON THIS ISSUE AS IT RELATES TO AVIATION SAFETY.

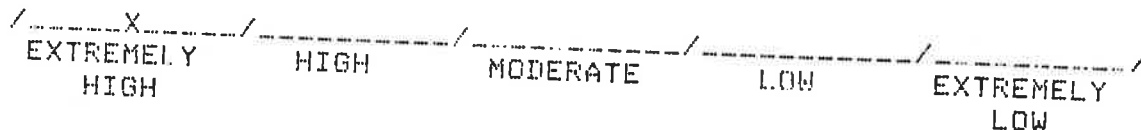

IV. SUPPLEMENTARY INFORMATION.

A. EVIDENCE FOR IMPORTANCE OF ISSUES:

These displays are coming. Some research going on by aircraft manufacturers in U.S. and U.K.

B. FUTURE RESEARCH PROJECTS NEEDED REGARDING THIS ISSUE:

See II above

C. APPLICATION OF FINDINGS - SAFETY, EFFICIENCY, AND/OR COST BENEFITS EXPECTED FROM FUTURE RESEARCH ON THIS ISSUE:

CRT's are expected to be cost beneficial; safety will be effected by quality of research and decisions resulting.

D. REFERENCES:

Human factors literature

E. (OPTIONAL) PARTICIPANT NAME: W. A. Jenson

IDENTIFICATION OF HUMAN FACTORS ISSUES IN AVIATION:  
BIOMEDICAL AND BEHAVIORAL FACTORS

I. TITLE OF ISSUE OR QUESTION:

Total Simulator vs. Airplane Training

II. SUMMARY OF ISSUE OR QUESTION:

More and more pilot training is being accomplished with simulators because of their increasing sophistication and the economic advantages offered. Yet, they are not a complete substitution for airplane time. In many cases, pilots do not approach problems in a simulator the same way they do in an airplane because of motivational problems or the way simulation training is conducted. Certain techniques such as Line-Oriented Flight Training (LOFT) can help alleviate some of these problems. None the less, this state of affairs is recent and deserves close scrutiny. How realistic must a simulator be in order to be as effective as airplane training?

III. RATE PRIORITY OF RESEARCH ON THIS ISSUE AS IT RELATES TO AVIATION SAFETY.

/-----X-----/-----/-----/-----/-----/  
EXTREMELY HIGH      HIGH      MODERATE      LOW      EXTREMELY LOW

IV. SUPPLEMENTARY INFORMATION.

A. EVIDENCE FOR IMPORTANCE OF ISSUES:

The new FAR allowing for eventual total simulator training and the relative absence of simulator vs airplane evaluations of the effectiveness of training.

B. FUTURE RESEARCH PROJECTS NEEDED REGARDING THIS ISSUE:

(above)

C. APPLICATION OF FINDINGS - SAFETY, EFFICIENCY, AND/OR COST BENEFITS EXPECTED FROM FUTURE RESEARCH ON THIS ISSUE:

If simulator training is proven roughly comparable, airplane time can be almost completely eliminated resulting in significant cost savings. However, training organizations must proceed with caution.

D. REFERENCES:

Line-Oriented Flight Training. Lauber & Foushee  
NASA CP 2184

E. (OPTIONAL) PARTICIPANT NAME: Dr. H. Clayton Foushee

IDENTIFICATION OF HUMAN FACTORS ISSUES IN AVIATION;  
BIOMEDICAL AND BEHAVIORAL FACTORS

I. TITLE OF ISSUE OR QUESTION:

Application of Automation

II. SUMMARY OF ISSUE OR QUESTION:

What type of automation is needed- should it perform actions on its own or monitor pilot actions?  
Distribution of controlling and monitoring functions between crew and computers.  
Difficulty of maintaining manual skills in an automated environment.

III. RATE PRIORITY OF RESEARCH ON THIS ISSUE AS IT RELATES TO AVIATION SAFETY,

/-----X-----/  
EXTREMELY HIGH      HIGH      MODERATE      LOW      EXTREMELY LOW

IV. SUPPLEMENTARY INFORMATION.

A. EVIDENCE FOR IMPORTANCE OF ISSUES:

Human is a poor monitor of infrequent events and failures. Pilots have difficulty transitioning from highly automated aircraft to mainly manual aircraft, e.g. First Officer on DC 10 to Captain on B-727. to be effective in emergency manual operations they must maintain skills through active involvement in routine operations.

B. FUTURE RESEARCH PROJECTS NEEDED REGARDING THIS ISSUE:

What is proper role of automation and how much can/should pilot be taken out of control and information loop as opposed to leaving him in loop and having computer monitor, advise and/or limit his actions.

C. APPLICATION OF FINDINGS - SAFETY, EFFICIENCY, AND/OR COST BENEFITS EXPECTED FROM FUTURE RESEARCH ON THIS ISSUE:

Controlled flight into terrain accidents have been virtually eliminated by G.P.W.S. Fuel and efficiency savings can be realized through flight management systems.

D. REFERENCES:

NASA Ames Automation report - Dr. Wiener and Dr. Boehm-Davis  
Aviation Psychology - Dr. Roscoe

E. (OPTIONAL) PARTICIPANT NAME: Dr. Roscoe/ Edmunds



IDENTIFICATION OF HUMAN FACTORS ISSUES IN AVIATION:  
BIOMEDICAL AND BEHAVIORAL FACTORS

I. TITLE OF ISSUE OR QUESTION:

Information presentation

II. SUMMARY OF ISSUE OR QUESTION:

With advanced flight displays, utilizing CRT technology, not enough attention has been given to flight information presentation, format, i.e., size, shape, color, symbology, for standardization to reduce error and fatigue.

III. RATE PRIORITY OF RESEARCH ON THIS ISSUE AS IT RELATES TO AVIATION SAFETY.

/-----X-----/-----/-----/-----/-----/  
EXTREMELY HIGH      HIGH      MODERATE      LOW      EXTREMELY LOW

IV. SUPPLEMENTARY INFORMATION.

A. EVIDENCE FOR IMPORTANCE OF ISSUES:

With the proliferation of CRT and advanced displays (HUD, Shared Radar Displays, Advanced avionics) have developed different displays with little attention to presentation of information.

B. FUTURE RESEARCH PROJECTS NEEDED REGARDING THIS ISSUE:

Committee should be established to determine human factors needs when developing advanced displays.

C. APPLICATION OF FINDINGS - SAFETY, EFFICIENCY, AND/OR COST BENEFITS EXPECTED FROM FUTURE RESEARCH ON THIS ISSUE:

This might not appear to be hot issue right now, but without consideration, we will face same problems as with cockpit standardization 20 years ago.

D. REFERENCES:

(new suggestion)

E. (OPTIONAL) PARTICIPANT NAME: Russell Lawton (ADPA)

IDENTIFICATION OF HUMAN FACTORS ISSUES IN AVIATION;  
BIOMEDICAL AND BEHAVIORAL FACTORS

I. TITLE OF ISSUE OR QUESTION:

Minimum Standards for Cockpit Visibility

II. SUMMARY OF ISSUE OR QUESTION:

Many current aircraft do not meet visibility standards specified in Title 14 of the Code of Federal Regulations. A draft advisory circular incorporates an SAE committee recommendation to relax these standards to allow even poorer visibility.

III. RATE PRIORITY OF RESEARCH ON THIS ISSUE AS IT RELATES TO AVIATION SAFETY.

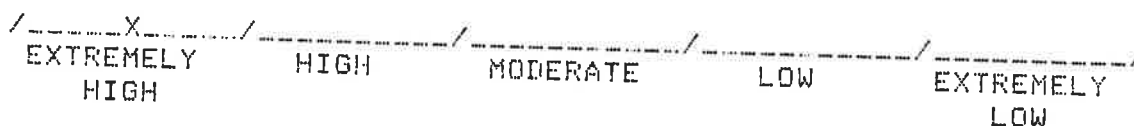

IV. SUPPLEMENTARY INFORMATION.

A. EVIDENCE FOR IMPORTANCE OF ISSUES:

There have been four mid-air collisions involving the DC-9 alone in which the other aircraft and/or its contrail was obscured or at least partially obscured from the view of one or both pilots by the nonstandard (oversized) window posts.

B. FUTURE RESEARCH PROJECTS NEEDED REGARDING THIS ISSUE:

Studies of probability of detection of nonmoving (collision course) targets of varying shapes, sizes, and contrast with background as a function of their spatial proximity to cockpit window posts of various widths.

C. APPLICATION OF FINDINGS - SAFETY, EFFICIENCY, AND/OR COST BENEFITS EXPECTED FROM FUTURE RESEARCH ON THIS ISSUE:

Establishment of the seriousness of the decrement in traffic detection performance associated with posts that exceed interpupillary width.

D. REFERENCES:

NTSB reports of accidents over Urbana, Ohio (1967); Fairland, Indiana (1970); and Duarte, California (1971). Yugoslav government report of accident over Zagreb (1976)

E. (OPTIONAL) PARTICIPANT NAME: Stan Roscoe

IDENTIFICATION OF HUMAN FACTORS ISSUES IN AVIATION:  
BIOMEDICAL AND BEHAVIORAL FACTORS

I. TITLE OF ISSUE OR QUESTION:

Operational Fatigue/Fatigue Management

II. SUMMARY OF ISSUE OR QUESTION:

Fatigue is the most frequently stated problem of pilots in airline operations. Fatigue embodies elements of physical exertion, sedentary periods, sleep disruptions, scheduling, day vs night flying and ground vs flight activities.

III. RATE PRIORITY OF RESEARCH ON THIS ISSUE AS IT RELATES TO AVIATION SAFETY.

/-----X-----/-----/-----/-----/-----/  
EXTREMELY HIGH      HIGH      MODERATE      LOW      EXTREMELY LOW

IV. SUPPLEMENTARY INFORMATION.

A. EVIDENCE FOR IMPORTANCE OF ISSUES:

Recent conferences; labor/management issue, popular press reflects public concern for safety

B. FUTURE RESEARCH PROJECTS NEEDED REGARDING THIS ISSUE:

Operational research; development of methods for objective assessment of "mental" fatigue

C. APPLICATION OF FINDINGS - SAFETY, EFFICIENCY, AND/OR COST BENEFITS EXPECTED FROM FUTURE RESEARCH ON THIS ISSUE:

all

D. REFERENCES:

NASA Conferences proceedings on "Desynchronization and Fatigue"  
- SFO, August, 1980.

E. (OPTIONAL) PARTICIPANT NAME: C. E. Melton

IDENTIFICATION OF HUMAN FACTORS ISSUES IN AVIATION:  
BIOMEDICAL AND BEHAVIORAL FACTORS

I. TITLE OF ISSUE OR QUESTION:

The effectiveness of Flight Path Control (altitude) Monitoring by electronic devices in the cockpit.

II. SUMMARY OF ISSUE OR QUESTION:

1. Reliability of the monitoring device in providing basic guidance
2. Lack of consistent and standardized operations.

III. RATE PRIORITY OF RESEARCH ON THIS ISSUE AS IT RELATES TO AVIATION SAFETY.

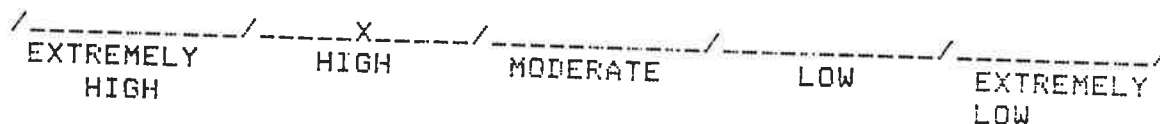

IV. SUPPLEMENTARY INFORMATION.

A. EVIDENCE FOR IMPORTANCE OF ISSUES:

1. Altitude deviations are a major problem
2. Altitude deviations degrade protection built into ATC system and can and do lead to near mid-air collisions.
3. Altitude warning systems are required by regulation and have not solved the problem.

B. FUTURE RESEARCH PROJECTS NEEDED REGARDING THIS ISSUE:

1. Design of standardized cockpit procedures which do not degrade their monitoring effectiveness.
2. Better Human Factors input into design and utilization of these & similar devices

C. APPLICATION OF FINDINGS - SAFETY, EFFICIENCY, AND/OR COST BENEFITS EXPECTED FROM FUTURE RESEARCH ON THIS ISSUE:

1. Increased Air Safety
2. Increased efficiency within ATC system (secondary)

D. REFERENCES:

1. FAR notice requiring altitude warnings systems in air carrier airplanes.
2. ASRS reports & studies regarding altitude deviations

E. (OPTIONAL) PARTICIPANT NAME: Harry W. Orledge

IDENTIFICATION OF HUMAN FACTORS ISSUES IN AVIATION:  
BIOMEDICAL AND BEHAVIORAL FACTORS

I. TITLE OF ISSUE OR QUESTION:

Maintenance of pilot qualifications in more than one aircraft.

II. SUMMARY OF ISSUE OR QUESTION:

Some operators require crews to maintain qualification on more than one aircraft and/or rotorcraft.

III. RATE PRIORITY OF RESEARCH ON THIS ISSUE AS IT RELATES TO AVIATION SAFETY.

/-----/-----X-----/-----/-----/  
EXTREMELY HIGH MODERATE LOW EXTREMELY  
HIGH LOW

IV. SUPPLEMENTARY INFORMATION.

A. EVIDENCE FOR IMPORTANCE OF ISSUES:

In a recent Airmicronesia accident, pilot error was cited as the probable cause because of habit patterns established from flying a previous piece of equipment.

B. FUTURE RESEARCH PROJECTS NEEDED REGARDING THIS ISSUE:

To what degree should the cockpit and procedures be more standardized to allow this procedure.

C. APPLICATION OF FINDINGS - SAFETY, EFFICIENCY, AND/OR COST BENEFITS EXPECTED FROM FUTURE RESEARCH ON THIS ISSUE:

This may tremendously enhance safety.

D. REFERENCES:

Airline Flight Standards, ALPA, and Military

E. (OPTIONAL) PARTICIPANT NAME: Duane Edelman

IDENTIFICATION OF HUMAN FACTORS ISSUES IN AVIATION:  
BIOMEDICAL AND BEHAVIORAL FACTORS

I. TITLE OF ISSUE OR QUESTION:

Cockpit Design philosophy - Human traits/crew station & design.

II. SUMMARY OF ISSUE OR QUESTION:

There are a number of new systems being developed for new and older aircraft that do not benefit from a design philosophy or standard that fully considers the human element.

III. RATE PRIORITY OF RESEARCH ON THIS ISSUE AS IT RELATES TO AVIATION SAFETY.

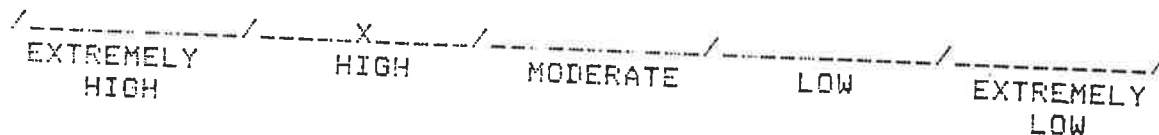

IV. SUPPLEMENTARY INFORMATION.

A. EVIDENCE FOR IMPORTANCE OF ISSUES:

There are several manufacturers who are building the same pieces of equipment with different design philosophies.  
Examples:

1. Flight management systems
2. Radio management systems
3. Beacon Collision Avoidance
4. Warning systems, aural and visual
5. CRT systems displays
6. Heads up display

B. FUTURE RESEARCH PROJECTS NEEDED REGARDING THIS ISSUE:

1. Location of instrumentation
2. Types of displays
3. Types of controls
4. Sequence of displays
5. Light colors
6. Field of sight
7. Comprehension

C. APPLICATION OF FINDINGS - SAFETY, EFFICIENCY, AND/OR COST BENEFITS EXPECTED FROM FUTURE RESEARCH ON THIS ISSUE:

The net results would be an increase in safety, less cost in training and improve standardization.

D. REFERENCES:

Airline Flight Standards, ALPA, NASA, and Private industry

E. (OPTIONAL) PARTICIPANT NAME: Duane Edelman, Republic Airlines

IDENTIFICATION OF HUMAN FACTORS ISSUES IN AVIATION:  
BIOMEDICAL AND BEHAVIORAL FACTORS

I. TITLE OF ISSUE OR QUESTION:

Workload requirements in various classes of operation (equipment operation)

II. SUMMARY OF ISSUE OR QUESTION:

What are the differences in cockpit workload requirements between single pilot, lightly equipped general aviation aircraft and multi-crew aircraft, operating IFR in high density terminal areas.

III. RATE PRIORITY OF RESEARCH ON THIS ISSUE AS IT RELATES TO AVIATION SAFETY.

/-----/-----X-----/-----/-----/  
EXTREMELY HIGH                  MODERATE                  LOW                  EXTREMELY LOW

IV. SUPPLEMENTARY INFORMATION.

A. EVIDENCE FOR IMPORTANCE OF ISSUES:

Traffic mix in high density areas  
Increased regulation of airspace

B. FUTURE RESEARCH PROJECTS NEEDED REGARDING THIS ISSUE:

Realistic way to assess variable cockpit workload requirements imposed by a procedure under consideration.

C. APPLICATION OF FINDINGS - SAFETY, EFFICIENCY, AND/OR COST BENEFITS EXPECTED FROM FUTURE RESEARCH ON THIS ISSUE:

Increased safety based on procedures designed with less opportunity for error caused by unrealistic information processing or crew workload requirements.

D. REFERENCES:

(new suggestion)

E. (OPTIONAL) PARTICIPANT NAME: Jan Million

IDENTIFICATION OF HUMAN FACTORS ISSUES IN AVIATION:  
BIOMEDICAL AND BEHAVIORAL FACTORS

I. TITLE OF ISSUE OR QUESTION:

Computer Assisted Instruction (CAI)

II. SUMMARY OF ISSUE OR QUESTION:

Should CAI be used as second level instruction to upgrade pilots to advanced Electronic displays?

III. RATE PRIORITY OF RESEARCH ON THIS ISSUE AS IT RELATES TO AVIATION SAFETY,

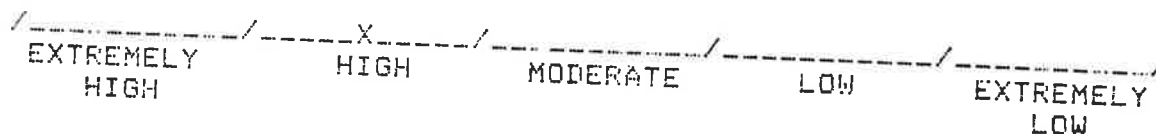

IV. SUPPLEMENTARY INFORMATION.

A. EVIDENCE FOR IMPORTANCE OF ISSUES:

Economics, simulator costs too high for training pilots on new displays and flight guidance systems. Table top terminals and other new training approaches will be coming to cut simulator costs.

B. FUTURE RESEARCH PROJECTS NEEDED REGARDING THIS ISSUE:

As to how much training time can be saved. Teach concepts with training costs and crew confidence factor as prime concerns.

C. APPLICATION OF FINDINGS - SAFETY, EFFICIENCY, AND/OR COST BENEFITS EXPECTED FROM FUTURE RESEARCH ON THIS ISSUE:

Better trained pilot to more efficiently utilize advanced displays, plus systems concepts.

D. REFERENCES:

(new suggestion)

E. (OPTIONAL) PARTICIPANT NAME: C. W. Connor



IDENTIFICATION OF HUMAN FACTORS ISSUES IN AVIATION:  
BIOMEDICAL AND BEHAVIORAL FACTORS

I. TITLE OF ISSUE OR QUESTION:

Cockpit standardization

II. SUMMARY OF ISSUE OR QUESTION:

Should the FAA require more standardization of flight deck equipment? Currently unlike the U.S. Military, there is little in the FAR's that requires that the location, size or shape of controls or displays be standardized.

III. RATE PRIORITY OF RESEARCH ON THIS ISSUE AS IT RELATES TO AVIATION SAFETY.

/-----/-----/-----X-----/-----/  
EXTREMELY HIGH      HIGH      MODERATE      LOW      EXTREMELY LOW

IV. SUPPLEMENTARY INFORMATION.

A. EVIDENCE FOR IMPORTANCE OF ISSUES:

Pilot flying different aircraft may suffer from habit interference when operating different equipment.

B. FUTURE RESEARCH PROJECTS NEEDED REGARDING THIS ISSUE:

New displays such as CRT and HUD, and the proliferation of digital control panel

C. APPLICATION OF FINDINGS - SAFETY, EFFICIENCY, AND/OR COST BENEFITS EXPECTED FROM FUTURE RESEARCH ON THIS ISSUE:

Safety, minimize error

D. REFERENCES:

NTSB "Aircraft Design Induced Errors" 1967, Fitts & Jones 1948  
Design Induced Landing Gear Accident in Beech-Baron & Bonanza  
A/C, NTSB Spec Invest 80-10

E. (OPTIONAL) PARTICIPANT NAME:-----

IDENTIFICATION OF HUMAN FACTORS ISSUES IN AVIATION:  
BIOMEDICAL AND BEHAVIORAL FACTORS

I. TITLE OF ISSUE OR QUESTION:

Self-Induced Stressors

II. SUMMARY OF ISSUE OR QUESTION:

Continue and expand the research of aircrew performance degradation due to self-induced stressors such as self-medication, drug abuse, poor sleep and eating patterns, alcohol, etc.

III. RATE PRIORITY OF RESEARCH ON THIS ISSUE AS IT RELATES TO AVIATION SAFETY.

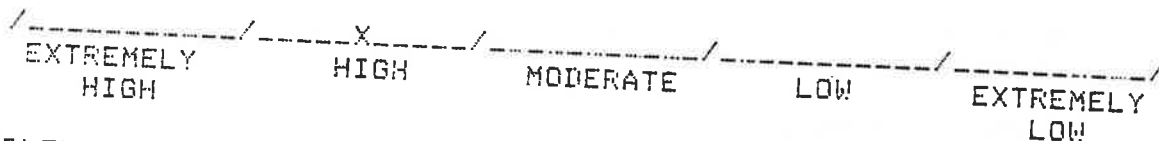

IV. SUPPLEMENTARY INFORMATION.

A. EVIDENCE FOR IMPORTANCE OF ISSUES:

High incidence of pilot caused aircraft accidents.

B. FUTURE RESEARCH PROJECTS NEEDED REGARDING THIS ISSUE:

Synergistic effects of altitude with items such as: Common cold remedies, sleep deprivation, residual effects of alcohol (over 8 hour fast drinking), reactive hypoglycemia. Not only consider single, but in combination.

C. APPLICATION OF FINDINGS - SAFETY, EFFICIENCY, AND/OR COST BENEFITS EXPECTED FROM FUTURE RESEARCH ON THIS ISSUE:

More than regulatory, suggest (dissemination of information through all possible avenues. Inclusion in various flight instruction programs throughout the spectrum of pilot ratings can be encouraged by ensuring these items are included in written examinations by FAA designated examiners.

D. REFERENCES:

CAMI of FAA and School of Aerospace Medicine of USAF  
Naval Safety Center, US Navy and Air Inspection and Safety Center, Norton AFB, CA

E. (OPTIONAL) PARTICIPANT NAME: Charles S. Erwin

IDENTIFICATION OF HUMAN FACTORS ISSUES IN AVIATION:  
BIOMEDICAL AND BEHAVIORAL FACTORS

I. TITLE OF ISSUE OR QUESTION:

Task performance criteria

II. SUMMARY OF ISSUE OR QUESTION:

Should/can minimum performance standards be set for pilot performance over and above current standards/resulations?

III. RATE PRIORITY OF RESEARCH ON THIS ISSUE AS IT RELATES TO AVIATION SAFETY.

/-----X-----/-----/-----/-----/-----/  
EXTREMELY HIGH      HIGH      MODERATE      LOW      EXTREMELY LOW

IV. SUPPLEMENTARY INFORMATION.

A. EVIDENCE FOR IMPORTANCE OF ISSUES:

Pilot's protest to "age 60" rule; accidents caused by pilot error.

B. FUTURE RESEARCH PROJECTS NEEDED REGARDING THIS ISSUE:

Are different standards required for different planes? Should standards be set at the end-point level (e.g. landing the plane) or at the subtask/factor level (e.g. reaction time)? Should performance standards be set for peak performance level, median level or lowest level exhibited by pilot? Should different standards be set for entry-level vs. experienced pilots. Are there compensating factors associated with age?

C. APPLICATION OF FINDINGS - SAFETY, EFFICIENCY, AND/OR COST BENEFITS EXPECTED FROM FUTURE RESEARCH ON THIS ISSUE:

D. REFERENCES:

Chiles: CAMI Reports  
NASA Reports

E. (OPTIONAL) PARTICIPANT NAME: G. Mohr

IDENTIFICATION OF HUMAN FACTORS ISSUES IN AVIATION:  
BIOMEDICAL AND BEHAVIORAL FACTORS

I. TITLE OF ISSUE OR QUESTION:

Development of methods for evaluating changes in functional and operational capabilities of aviation personnel produced by environmental and medical factors including aging.

II. SUMMARY OF ISSUE OR QUESTION:

Many factors, such as increasing age, cerebro-vascular accidents and traumatic head injury, can affect the functional capabilities of a pilot. There are now no generally accepted methods for evaluating such capabilities, a fact underlying much of the controversy over the "Age 60" rule. Such measures are needed to resolve this, and related problems.

III. RATE PRIORITY OF RESEARCH ON THIS ISSUE AS IT RELATES TO AVIATION SAFETY.

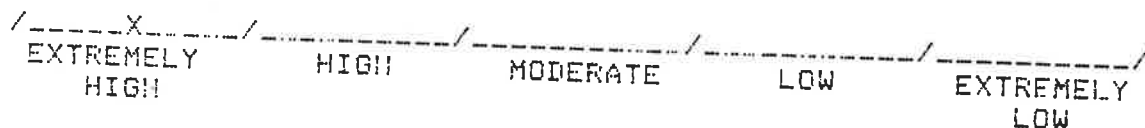

IV. SUPPLEMENTARY INFORMATION.

A. EVIDENCE FOR IMPORTANCE OF ISSUES:

Recent bitter controversy regarding "Age 60 Rule"

B. FUTURE RESEARCH PROJECTS NEEDED REGARDING THIS ISSUE:

Many organized groups a) Behavioral Responses to complex stimulus tasks; b) Electrophysiological analysis of potentials evoked by complex stimulus arrays; Animal models and human subjects.

C. APPLICATION OF FINDINGS - SAFETY, EFFICIENCY, AND/OR COST BENEFITS EXPECTED FROM FUTURE RESEARCH ON THIS ISSUE:

Development of suitable testing methods would provide acceptable basis for retirement criteria for aviation personnel in critical tasks.

D. REFERENCES:

(new suggestion)

E. (OPTIONAL) PARTICIPANT NAME: A. Revzin

IDENTIFICATION OF HUMAN FACTORS ISSUES IN AVIATION:  
BIOMEDICAL AND BEHAVIORAL FACTORS

I. TITLE OF ISSUE OR QUESTION:

Judgment

II. SUMMARY OF ISSUE OR QUESTION:

"Poor Judgment" is responsible for most GA accidents. Can "good Judgment" be taught or measured.

III. RATE PRIORITY OF RESEARCH ON THIS ISSUE AS IT RELATES TO AVIATION SAFETY.

/-----X-----/-----/-----/-----/-----/  
EXTREMELY HIGH      HIGH      MODERATE      LOW      EXTREMELY LOW

IV. SUPPLEMENTARY INFORMATION.

A. EVIDENCE FOR IMPORTANCE OF ISSUES:

Jensen & Benel, 1967 (FAA Report) stated that the majority of accidents (based on NTSB files) were due to causes which could be classified as Judgment failure. Can this good Judgment be taught and how best to do this.

B. FUTURE RESEARCH PROJECTS NEEDED REGARDING THIS ISSUE:

Emery Riddle Study to be completed in 1982.

C. APPLICATION OF FINDINGS - SAFETY, EFFICIENCY, AND/OR COST BENEFITS EXPECTED FROM FUTURE RESEARCH ON THIS ISSUE:

safety

D. REFERENCES:

FAA contract reports

E. (OPTIONAL) PARTICIPANT NAME: \_\_\_\_\_

IDENTIFICATION OF HUMAN FACTORS ISSUES IN AVIATION:  
BIOMEDICAL AND BEHAVIORAL FACTORS

I. TITLE OF ISSUE OR QUESTION:

Resource Management, Crew Coordination, The Role Structure of the Cockpit.

II. SUMMARY OF ISSUE OR QUESTION:

The nature of interpersonal processes in the cockpit has played a role in a significant number of accidents. For example, subordinate crew members are sometimes hesitant to question captains or speak up in potentially dangerous situations. It is also clear that personality plays a role in that process. Little research has been undertaken to clarify the processes.

III. RATE PRIORITY OF RESEARCH ON THIS ISSUE AS IT RELATES TO AVIATION SAFETY.

/-----X-----/-----/-----/-----/-----/  
EXTREMELY HIGH      HIGH      MODERATE      LOW      EXTREMELY LOW

IV. SUPPLEMENTARY INFORMATION.

A. EVIDENCE FOR IMPORTANCE OF ISSUES:

Air carrier incidents and accidents. Full-mission simulation research. Interviews with pilots.

B. FUTURE RESEARCH PROJECTS NEEDED REGARDING THIS ISSUE:

Personality research. Evaluation in realistic simulated environment. Observational and interview studies with air carriers.

C. APPLICATION OF FINDINGS - SAFETY, EFFICIENCY, AND/OR COST BENEFITS EXPECTED FROM FUTURE RESEARCH ON THIS ISSUE:

Implications for selection and training. Impacts the overall safety of the operation and the way cockpit resources are managed.

D. REFERENCES:

Cockpit Resource Management NASA CP 2120

E. (OPTIONAL) PARTICIPANT NAME: Dr. H. Clayton Forshee

IDENTIFICATION OF HUMAN FACTORS ISSUES IN AVIATION:  
BIOMEDICAL AND BEHAVIORAL FACTORS

I. TITLE OF ISSUE OR QUESTION:

The relationship between inadequate stress coping strategies and aircrew performance.

II. SUMMARY OF ISSUE OR QUESTION:

According to many psychiatric studies, aviators who are not coping with the ongoing life stresses to which everyone is subject will tend to "Act Out" their frustration through aggression directed outward at others (or toward inanimate objects such as the aircraft), and through alcohol abuse and violation of regulations (aviation or motor vehicle) which may tend to make them accident-prone.

III. RATE PRIORITY OF RESEARCH ON THIS ISSUE AS IT RELATES TO AVIATION SAFETY.

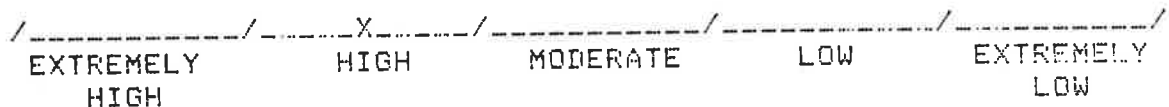

IV. SUPPLEMENTARY INFORMATION.

A. EVIDENCE FOR IMPORTANCE OF ISSUES:

A recent unpublished study has demonstrated a relationship between airmen who present the symptoms of inappropriate stress coping strategies in "acting out" their aggressions and frustrations and those involved as causal or contributory factors in aircraft mishaps.

B. FUTURE RESEARCH PROJECTS NEEDED REGARDING THIS ISSUE:

To further define the symptoms of inadequate stress coping and the relationship between this and aircrew performance.

C. APPLICATION OF FINDINGS - SAFETY, EFFICIENCY, AND/OR COST BENEFITS EXPECTED FROM FUTURE RESEARCH ON THIS ISSUE:

Definition of inadequate stress-coping symptoms for use by flight instructors, those responsible for selection training and scheduling of aviators, and aviation managers will enable the non-selection of low stress copers and allow training for alternate adequate stress coping strategies.

D. REFERENCES:

Alkov, R.A. "Inadequate Stress Coping strategies and the Aircrew Factor caused Mishap in the US Navy" unpublished Naval Safety Center Research Report, June 1981.

E. (OPTIONAL) PARTICIPANT NAME: Robert A. Alkov

IDENTIFICATION OF HUMAN FACTORS ISSUES IN AVIATION:  
BIOMEDICAL AND BEHAVIORAL FACTORS

I. TITLE OF ISSUE OR QUESTION:

Visual Accommodation Effects on Pilot Performance

II. SUMMARY OF ISSUE OR QUESTION:

Empty-field myopia; night myopia and hyperopia; and instrument myopia caused by imaging displays all cause misperceptions of size and distance in flight.

III. RATE PRIORITY OF RESEARCH ON THIS ISSUE AS IT RELATES TO AVIATION SAFETY.

/-----X-----/-----/-----/-----/-----/-----/  
EXTREMELY HIGH      HIGH      MODERATE      LOW      EXTREMELY LOW

IV. SUPPLEMENTARY INFORMATION.

A. EVIDENCE FOR IMPORTANCE OF ISSUES:

Experiments conducted at Ames Research Center, the University of Illinois, and New Mexico State University have shown high correlations between visual accommodation and perception of size and distance.

B. FUTURE RESEARCH PROJECTS NEEDED REGARDING THIS ISSUE:

Specific effects of collimated imaging displays on visual responses and effectiveness to biofeedback trainings.

C. APPLICATION OF FINDINGS - SAFETY, EFFICIENCY, AND/OR COST BENEFITS EXPECTED FROM FUTURE RESEARCH ON THIS ISSUE:

Possibility of training pilots to recognize and voluntarily compensate for flight conditions and equipment that cause misaccommodation.

D. REFERENCES:

Various papers and technical reports by R.J. Randle, R.T. Hennessee, S.N. Roscoe and their associates.

E. (OPTIONAL) PARTICIPANT NAME: S. N. Roscoe



IDENTIFICATION OF HUMAN FACTORS ISSUES IN AVIATION:  
BIOMEDICAL AND BEHAVIORAL FACTORS

I. TITLE OF ISSUE OR QUESTION:

Peak & Minimum (Extreme) Workload limits

II. SUMMARY OF ISSUE OR QUESTION:

Do extremely high and/or low levels of crew activity (workload) lead to unsafe situations. A Related issue is to determine the correlation (positive or negative) between workload and safety (as determined by satisfactory task performance).

III. RATE PRIORITY OF RESEARCH ON THIS ISSUE AS IT RELATES TO AVIATION SAFETY.

/-----X-----/-----/-----/-----/-----/  
EXTREMELY HIGH      HIGH      MODERATE      LOW      EXTREMELY LOW

IV. SUPPLEMENTARY INFORMATION.

A. EVIDENCE FOR IMPORTANCE OF ISSUES:

Accidents have occurred for which the commonly accepted cause was either that the crew was too busy or was inattentive due to low activity levels.

B. FUTURE RESEARCH PROJECTS NEEDED REGARDING THIS ISSUE:

Assuming the existence of an appropriate workload metric, utilize operational type simulators (such as during LOFT) to correlate workload (instantaneous and time history) with task performance (procedural errors, reaction times, aircraft control accuracy)

C. APPLICATION OF FINDINGS - SAFETY, EFFICIENCY, AND/OR COST BENEFITS EXPECTED FROM FUTURE RESEARCH ON THIS ISSUE:

Cockpit crew station design.  
Aircraft certification process.

D. REFERENCES:

Thackray - FAA CAMI (minimum)  
Chiles - FAA CAMI (maximum)

E. (OPTIONAL) PARTICIPANT NAME: Roger P. Neeland - FAA/ARD 340

IDENTIFICATION OF HUMAN FACTORS ISSUES IN AVIATION:  
BIOMEDICAL AND BEHAVIORAL FACTORS

I. TITLE OF ISSUE OR QUESTION:

Disturbed sleep patterns associated with civil transport flight

II. SUMMARY OF ISSUE OR QUESTION:

Civil flights, particularly long haul, tend to produce disturbed sleep patterns in crew - alternate day & night flights - 24 hour schedule tend to force crews to need short sleeps at inappropriate times. Sleep loss/disturbance affects performance in particular ways.

III. RATE PRIORITY OF RESEARCH ON THIS ISSUE AS IT RELATES TO AVIATION SAFETY.

/-----/-----X-----/-----/-----/  
EXTREMELY HIGH      HIGH      MODERATE      LOW      EXTREMELY LOW

IV. SUPPLEMENTARY INFORMATION.

A. EVIDENCE FOR IMPORTANCE OF ISSUES:

Recent work has shown sleep loss does not greatly effect well-learned handling performance, e.g. I.F. but tends to narrow attention, & increase the number of procedural blunders. ASRS Study (Orlando) identified crew complaints that s/d was associated with incidents.

B. FUTURE RESEARCH PROJECTS NEEDED REGARDING THIS ISSUE:

1. Confirm types of sleep patterns in various kinds of operations.
2. Analyze flying tasks in terms of activities vulnerable to sleep loss effects.
3. Devise operational procedures to counter possible blunders.

C. APPLICATION OF FINDINGS - SAFETY, EFFICIENCY, AND/OR COST BENEFITS EXPECTED FROM FUTURE RESEARCH ON THIS ISSUE:

safety

D. REFERENCES:

ASRS Study (Orlando)  
Howitt et. al Aerospace 1978 EEG & Fatigue

E. (OPTIONAL) PARTICIPANT NAME: John Howitt & Robin Dodge

IDENTIFICATION OF HUMAN FACTORS ISSUES IN AVIATION:  
BIOMEDICAL AND BEHAVIORAL FACTORS

I. TITLE OF ISSUE OR QUESTION:

The effects of fatigue on flight safety in long duration flights.

II. SUMMARY OF ISSUE OR QUESTION:

In the restricted context of long duty periods aloft, components of fatigue (biological and environmental) need to be identified, their effects quantified, and potential counteractants assessed for diminution of adverse fatigue effects on flight-related functions.

III. RATE PRIORITY OF RESEARCH ON THIS ISSUE AS IT RELATES TO AVIATION SAFETY.

/-----/-----X-----/-----/-----/-----/  
EXTREMELY HIGH      HIGH      MODERATE      LOW      EXTREMELY LOW

IV. SUPPLEMENTARY INFORMATION.

A. EVIDENCE FOR IMPORTANCE OF ISSUES:

Fatigue continues to be listed as a substantial component in aviation accidents, but remains uncharacterized as to its specific components.

B. FUTURE RESEARCH PROJECTS NEEDED REGARDING THIS ISSUE:

Identification and quantitation of components of fatigue in long duration flights. Assessment of counteractants to fatigue.

C. APPLICATION OF FINDINGS - SAFETY, EFFICIENCY, AND/OR COST BENEFITS EXPECTED FROM FUTURE RESEARCH ON THIS ISSUE:

Reduction of adverse effects of fatigue on aviation safety.

D. REFERENCES:

CAMI Reports, Mohler; Physiological Index.

E. (OPTIONAL) PARTICIPANT NAME: C.W. Connor, Harry W. Orledge,  
and Michael T. Letesola

IDENTIFICATION OF HUMAN FACTORS ISSUES IN AVIATION:  
BIOMEDICAL AND BEHAVIORAL FACTORS

I. TITLE OF ISSUE OR QUESTION:

Inflight nutrition, dehydration and restricted motion (mobility)

II. SUMMARY OF ISSUE OR QUESTION:

Is there a need to research the long and short term effects of nutrition, dehydration and limited motion or activity relative to pilot "on duty" awareness.

III. RATE PRIORITY OF RESEARCH ON THIS ISSUE AS IT RELATES TO AVIATION SAFETY.

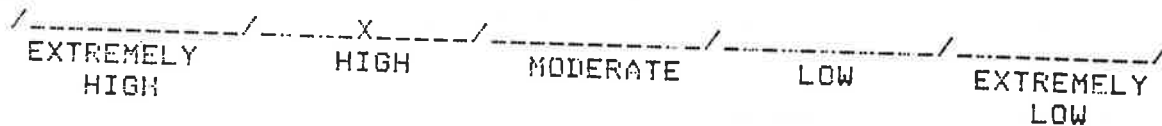

IV. SUPPLEMENTARY INFORMATION.

A. EVIDENCE FOR IMPORTANCE OF ISSUES:

NASA ASRS  
Accident investigating by military, ALPA, NTSB, & FAA  
where fatigue was a factor.

B. FUTURE RESEARCH PROJECTS NEEDED REGARDING THIS ISSUE:

- 1) Study of physiological aspects of food digestion as it affects pilot due to limited duty activity (physical)
- 2) Study of nutrient needs due to special environment
- 3) Study to find correlation in circadian sleep rhythms and nutritional needs involved in the pilot alertness.
- 4) Actual effects of digestive process on meal served in flight on pilots physiology.

C. APPLICATION OF FINDINGS - SAFETY, EFFICIENCY, AND/OR COST BENEFITS EXPECTED FROM FUTURE RESEARCH ON THIS ISSUE:

D. REFERENCES:

(new suggestion)

E. (OPTIONAL) PARTICIPANT NAME: Capt. Hal Nord

IDENTIFICATION OF HUMAN FACTORS ISSUES IN AVIATION:  
BIOMEDICAL AND BEHAVIORAL FACTORS

I. TITLE OF ISSUE OR QUESTION:

Interactions of toxic substances with other external factors.

II. SUMMARY OF ISSUE OR QUESTION:

The human brain is an exceptionally efficient computer; Many common toxic agents (e.g., alcohol, nicotine, fuel/lubricant fumes, gardening pesticides) can affect its operation and increase accident/error probability. At present, there is surprisingly little data on effects of these toxic agents on performance--even for alcohol. Such data, in our smoke and chemical inundated environment is urgently needed as basis for regulatory or educational policy.

III. RATE PRIORITY OF RESEARCH ON THIS ISSUE AS IT RELATES TO AVIATION SAFETY.

/-----/-----X-----/-----/-----/  
EXTREMELY HIGH      HIGH      MODERATE      LOW      EXTREMELY LOW

IV. SUPPLEMENTARY INFORMATION.

A. EVIDENCE FOR IMPORTANCE OF ISSUES:

Alcohol, marijuana, pesticides, and possibly, lubricant fumes are known vectors of accident causation. The little data existing for other agents suggests that there are a lot more things out there that can, without our knowing, interfere with flight-related brain functions.

B. FUTURE RESEARCH PROJECTS NEEDED REGARDING THIS ISSUE:

Systematic attack on acute and chronic neurobehavioral toxicology of substances to which aviation personnel (pilots) are commonly, or frequently, exposed.

C. APPLICATION OF FINDINGS - SAFETY, EFFICIENCY, AND/OR COST BENEFITS EXPECTED FROM FUTURE RESEARCH ON THIS ISSUE:

Restricting exposure to substances known, or shown, to cause impaired performance will reduce frequency of performance errors, and crashes.

D. REFERENCES:

(new suggestion)

E. (OPTIONAL) PARTICIPANT NAME: A. Revzin

IDENTIFICATION OF HUMAN FACTORS ISSUES IN AVIATION:  
BIOMEDICAL AND BEHAVIORAL FACTORS

I. TITLE OF ISSUE OR QUESTION:

Cockpit noise and vibration

II. SUMMARY OF ISSUE OR QUESTION:

No published studies available for noise and vibration in new and/or old general aviation aircraft and related effects on pilot fatigue.

III. RATE PRIORITY OF RESEARCH ON THIS ISSUE AS IT RELATES TO AVIATION SAFETY.

/-----/-----/-----X-----/-----/  
EXTREMELY HIGH      HIGH      MODERATE      LOW      EXTREMELY LOW

IV. SUPPLEMENTARY INFORMATION.

A. EVIDENCE FOR IMPORTANCE OF ISSUES:

Wide range of noise which occurs in light aircraft can cause pilot fatigue and increase likelihood of pilot error.

B. FUTURE RESEARCH PROJECTS NEEDED REGARDING THIS ISSUE:

Inflight testing of light aircraft cockpits for both new and old aircraft, demonstrating deterioration of cabin sound proofing and increased noise as aircraft ages.

C. APPLICATION OF FINDINGS - SAFETY, EFFICIENCY, AND/OR COST BENEFITS EXPECTED FROM FUTURE RESEARCH ON THIS ISSUE:

Findings of noise levels should be correlated with levels of performance decrement. Standards should be established for light aircraft cockpit noise levels.

D. REFERENCES:

Insufficient data available from accident investigation to show long term effects on fatigue.

E. (OPTIONAL) PARTICIPANT NAME: Russell Lawton (AOPA)

IDENTIFICATION OF HUMAN FACTORS ISSUES IN AVIATION:  
BIOMEDICAL AND BEHAVIORAL FACTORS

I. TITLE OF ISSUE OR QUESTION:

Biological rhythms

II. SUMMARY OF ISSUE OR QUESTION:

Are performance parameters critical for aviation safety significantly different during different phases of circadian or ultradian rhythms. Are there biorhythm phase differences in efficacy of factors which may influence performance (drug state, drug withdrawal, workload, sleep deprivation, etc)? In what ways does rhythm desynchrony influence performance? Are there ways to minimize any performance impairments resulting from rhythm desynchronies like "jet lag".

III. RATE PRIORITY OF RESEARCH ON THIS ISSUE AS IT RELATES TO AVIATION SAFETY.

/-----/-----/-----X-----/-----/-----/  
EXTREMELY HIGH      HIGH      MODERATE      LOW      EXTREMELY LOW

IV. SUPPLEMENTARY INFORMATION.

A. EVIDENCE FOR IMPORTANCE OF ISSUES:

Many performance parameters and most physiological and drug-response parameters have been shown to display major circadian fluctuations and occasionally minor ultradian ones. Phase-shifts or desynchrony of circadian rhythms may result from rapid time zone change, changes in workshift or even drugs. During desynchrony various physiological and behavioral changes can occur.

B. FUTURE RESEARCH PROJECTS NEEDED REGARDING THIS ISSUE:

Which performance parameter potentially relevant for aviation safety (e.g. attention, short-term memory) may be significantly impaired during 1) certain circadian rhythm phases or 2) during circadian rhythm desynchrony. What factors maximally produce rhythm desynchrony? What manipulations may mitigate the deleterious effects of rhythm desynchrony on performance, etc.? Other questions: 1) does desynchronosis interact with other factors (drugs, workload, sleep deprivation, etc) to adversely affect performance? 2) Does desynchronosis have retroactive effects, e.g. on recall of information? 3) Are any "time of day" differences in performance due to "true circadian rhythms or to other factors such as food, water, sleep deprivation, etc.?

C. APPLICATION OF FINDINGS - SAFETY, EFFICIENCY, AND/OR COST BENEFITS EXPECTED FROM FUTURE RESEARCH ON THIS ISSUE:

- 1) Reassessment of work schedule and workload regimens following transmeridian flights.
- 2) Reassessment or reassignment of man/machine configurations during different times of day.

D. REFERENCES:

Higgins, et.al. : CAMI Reports

E. (OPTIONAL) PARTICIPANT NAME: Frank A. Holloway, Ph.D.

IDENTIFICATION OF HUMAN FACTORS ISSUES IN AVIATION:  
BIOMEDICAL AND BEHAVIORAL FACTORS

I. TITLE OF ISSUE OR QUESTION:

Examination of data regarding recent accident (non-fatal and fatal) by competent human factors specialists (preferably with pilot experience)

II. SUMMARY OF ISSUE OR QUESTION:

Objectives: to recommend actions to avoid accidents; to determine need for and priority for further human factor research; and to recommend what further human factors data needs to be examined and recorded in future accident investigations.

III. RATE PRIORITY OF RESEARCH ON THIS ISSUE AS IT RELATES TO AVIATION SAFETY.

/-----X-----/-----/-----/-----/-----/  
EXTREMELY HIGH      HIGH      MODERATE      LOW      EXTREMELY LOW

IV. SUPPLEMENTARY INFORMATION.

A. EVIDENCE FOR IMPORTANCE OF ISSUES:

Continuing accidents with cause factors that are not fully assessed.

B. FUTURE RESEARCH PROJECTS NEEDED REGARDING THIS ISSUE:

Use of a special outside human factors group to review past 5-10 years complete NTSB files on each accident.

C. APPLICATION OF FINDINGS - SAFETY, EFFICIENCY, AND/OR COST BENEFITS EXPECTED FROM FUTURE RESEARCH ON THIS ISSUE:

Data to be used in prevention programs as indicated.

D. REFERENCES:

(new suggestion)

E. (OPTIONAL) PARTICIPANT NAME: W. A. Jensen



IDENTIFICATION OF HUMAN FACTORS ISSUES IN AVIATION: BIOMEDICAL AND BEHAVIORAL FACTORS:

I. Title of Issue or question:

Human Factors Issues at General Aviation Airports

II. Summary of Issue or question:

To what extent do airport conditions (operations and physical features) influence piloting aircraft in approach, landing, taxiing, and takeoff maneuvers--and how can adverse effects be ameliorated? (See attached sheet for more.)

III. Rate priority of research on this issue as it relates to aviation safety.

          X          /          X          /          /          /            
Extremely High      Moderate      Low      Extremely low  
High

IV. Supplementary information.

A. Evidence for importance of issues:

Airports are cited as causal and contributing to both air carrier and general aviation aircraft accidents. The frequency of citations are considered significant enough to warrant research & development efforts to focus on airport conditions to produce the knowledge & information upon which improvement can be based.

B. Future research projects needed regarding this issue:

Present efforts are not addressing airport issues, but are instead focusing on the man and his relationship to the machine.

C. Application of Findings - Safety, efficiency, and/or cost benefits expected from future research on this issue:

Findings will have a direct and positive effect on safety and efficiency of operations at airports. They can be applied through the FAA's Airport Development Aid Program and other agency efforts.

D. References:

E. (Optional) Participant name: John Kal, AAS-320

Please return by Aug 9, 1981

TO: Dr. Henry W. Mertens  
FAA/CAMI, AAC-118  
P.O. Box 25082  
Oklahoma City, OK. 73125

Attachment to: Identification of Human Factors Issues in Aviation:  
Biomedical and Behavioral Factors

Item II (continued)

For light conditions experienced during daylight:

- o What airport features and conditions influence pilots to land aircraft short of runways and how can this be corrected? To what extent are they correctable?
- o What airport features and conditions influence pilots in making flare maneuvers? Can they be corrected?
- o What airport features and conditions influence pilots to overshoot runways? Are better cues needed?
- o Do runway widths and other features create illusions of speeds greater or less than indicated by instruments? To what extent can they influence stopping distances?
- o Can airport lighting (clarity and configuration) be objectively evaluated from ground surface positions which duplicate the cues it provides during approach, landing, and takeoff?
- o Do point light sources similar to present day VASI's alone provide the best (optimal) vertical guidance?
- o Does the color of lighting (the often referred to "sea of blue lights" for taxiways) offer adequate guidance for maneuvering aircraft?
- o Do terrain features immediately surrounding airports (within 5-miles on approach, within the last mile by quarter mile increments) influence pilot maneuvers of aircraft and with what effects?

These questions are by no means exhaustive but are representative of areas where research and development by human factors specialists are believed to be needed. They are intended to stimulate and guide the make up of projects and programs that will produce, if not the answers to them, a better understanding of the interactions between airports and pilots.

#### IV. Supplemental Information

##### A. Evidence

CAMI, through Mertens and others, has demonstrated how runway features (length to width ratios) affect angles of approach in the landing maneuver of aircraft. This was done for dark night conditions. Perhaps more importantly, these kinds of efforts should be pursued for other than these conditions. A review of NTSB data on Conditions of Light by Injury Index shows a greater number of injuries in general aviation flying occurring in other conditions. For example, over a 3-year period, there are average annual occurrences of 39 fatalities during daylight conditions, 2 during moonlight night conditions, one at dusk, one during dark night, and none at dawn. Focusing human factors/airports research efforts on daylight conditions, therefore, could produce a greater benefit.

Additional support for such efforts comes from another source. An analysis of aircraft accidents was made by a NASA contractor which tends to corroborate NTSB's finds that airports exert a good deal of influence in aircraft accidents. In analyzing air carrier aircraft accidents, the contractor found in 32 out of 58 air carrier accidents, that airport conditions were second only to pilot experience as causal or contributory in accident occurrences.

Consulting NTSB records further and then looking at general aviation aircraft accidents adds another supporting argument. Here, on average in about 8 percent of the occurrences annually, airport conditions are cited as influencing accidents.

Human factors research in the highway field of transportation has proven itself beneficial. One need only consult Highway Research Board and National Cooperative Highway Research Program publications for evidence of this. While operations do not take place in the same mediums, there are enough similarities in operators, vehicles, and paths to suggest the same degree of success for human factors/airports research.

D. References

Mertens, H.W. and Lewis, M.F. Effect of Different Runway Size on Pilot Performance During Simulated Night Landing Approaches, CAMI; 1981 Article in Aviation Space Environmental Medicine.

Mertens, H.W. Runway Image Slope as a Clue for Judgment of Approach Angle, FAA/CAMI, Report FAA-AM-79-25, November 1979.

Kovalsky, N.B. etal. An Analyses of Pilot Error-Related Aircraft Accidents, NASA Report CR 2444, Washington, D.C., June 1979.

Various publications on human factors in Highway Research Reports and National Coperative Highway Research Program Reports dealing with such topics as polarized head lights, highway street and lane widths, proximity of guard rails to shoulders, etc.

QUESTIONNAIRES DISTRIBUTED IN WORKSHOP B, BIOMEDICAL AND BEHAVIORAL  
FACTORS IN THE PERFORMANCE OF AIR TRAFFIC CONTROL SPECIALISTS

IDENTIFICATION OF HUMAN FACTORS ISSUES IN AVIATION:  
BIOMEDICAL AND BEHAVIORAL FACTORS

I. TITLE OF ISSUE OR QUESTION:

ID of ATC task characteristics

II. SUMMARY OF ISSUE OR QUESTION:

Much speculation exists about what the ATC task actually involves. Performance is often judged by subjective ratings. An objective measure derived by researchers in cooperation with ATCS would be an important initial step in assessing automation needs and potentials, developing job motivators, revising ATC training, etc.

III. RATE PRIORITY OF RESEARCH ON THIS ISSUE AS IT RELATES TO AVIATION SAFETY.

/-----X-----/-----/-----/-----/-----/  
EXTREMELY HIGH      HIGH      MODERATE      LOW      EXTREMELY LOW

IV. SUPPLEMENTARY INFORMATION.

A. EVIDENCE FOR IMPORTANCE OF ISSUES:

Kinney S.O.P. research  
S. Tucker's current research  
ASRS results on error attribution

B. FUTURE RESEARCH PROJECTS NEEDED REGARDING THIS ISSUE:

Evaluation of ATC task in Cognitive Psychology/System Analysis Terms.

C. APPLICATION OF FINDINGS - SAFETY, EFFICIENCY, AND/OR COST BENEFITS EXPECTED FROM FUTURE RESEARCH ON THIS ISSUE:

Basis for work situation motivation (improved labor relations)  
Cut training costs, build cooperation ATC/FAA

D. REFERENCES:

E. (OPTIONAL) PARTICIPANT NAME: C. Graham

IDENTIFICATION OF HUMAN FACTORS ISSUES IN AVIATION:  
BIOMEDICAL AND BEHAVIORAL FACTORS

I. TITLE OF ISSUE OR QUESTION:

II. SUMMARY OF ISSUE OR QUESTION:

Need micro analysis of controller task performance to provide a basis for assessing impact of changes in controller work on controller workload and on traits and knowledge required to be a good controller.

III. RATE PRIORITY OF RESEARCH ON THIS ISSUE AS IT RELATES TO AVIATION SAFETY.

/-----/-----/-----/-----/-----/  
EXTREMELY HIGH      HIGH      MODERATE      LOW      EXTREMELY LOW  
HIGH

IV. SUPPLEMENTARY INFORMATION.

A. EVIDENCE FOR IMPORTANCE OF ISSUES:

B. FUTURE RESEARCH PROJECTS NEEDED REGARDING THIS ISSUE:

C. APPLICATION OF FINDINGS - SAFETY, EFFICIENCY, AND/OR COST BENEFITS EXPECTED FROM FUTURE RESEARCH ON THIS ISSUE:

D. REFERENCES:

E. (OPTIONAL) PARTICIPANT NAME:-----

IDENTIFICATION OF HUMAN FACTORS ISSUES IN AVIATION:  
BIOMEDICAL AND BEHAVIORAL FACTORS

I. TITLE OF ISSUE OR QUESTION:

II. SUMMARY OF ISSUE OR QUESTION:

Need to study the social aspects of the controller work environment to find means of increasing levels of Job satisfaction and perhaps Job performance.

III. RATE PRIORITY OF RESEARCH ON THIS ISSUE AS IT RELATES TO AVIATION SAFETY.

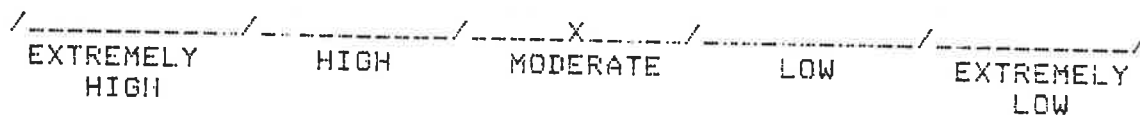

IV. SUPPLEMENTARY INFORMATION.

A. EVIDENCE FOR IMPORTANCE OF ISSUES:

B. FUTURE RESEARCH PROJECTS NEEDED REGARDING THIS ISSUE:

C. APPLICATION OF FINDINGS - SAFETY, EFFICIENCY, AND/OR COST BENEFITS EXPECTED FROM FUTURE RESEARCH ON THIS ISSUE:

D. REFERENCES:

E. (OPTIONAL) PARTICIPANT NAME: \_\_\_\_\_



IDENTIFICATION OF HUMAN FACTORS ISSUES IN AVIATION:  
BIOMEDICAL AND BEHAVIORAL FACTORS

I. TITLE OF ISSUE OR QUESTION:

Skills Analysis

II. SUMMARY OF ISSUE OR QUESTION:

A comprehensive skills analysis that specifies the knowledges, skills, and abilities necessary for ATC Job performance is needed as a basis for many areas of human factors research on ATC.

III. RATE PRIORITY OF RESEARCH ON THIS ISSUE AS IT RELATES TO AVIATION SAFETY.

/-----X-----/-----/-----/-----/-----/  
EXTREMELY HIGH      HIGH      MODERATE      LOW      EXTREMELY LOW

IV. SUPPLEMENTARY INFORMATION.

A. EVIDENCE FOR IMPORTANCE OF ISSUES:

Basic to many other areas of research

B. FUTURE RESEARCH PROJECTS NEEDED REGARDING THIS ISSUE:

C. APPLICATION OF FINDINGS - SAFETY, EFFICIENCY, AND/OR COST BENEFITS EXPECTED FROM FUTURE RESEARCH ON THIS ISSUE:

High cost benefit - as a basis for many research projects

D. REFERENCES:

E. (OPTIONAL) PARTICIPANT NAME:-----



IDENTIFICATION OF HUMAN FACTORS ISSUES IN AVIATION:  
BIOMEDICAL AND BEHAVIORAL FACTORS

I. TITLE OF ISSUE OR QUESTION:

Objective measures of Air Traffic System performance

II. SUMMARY OF ISSUE OR QUESTION:

Objective measures that are accurate and comprehensive are necessary as tools for evaluating alternative future systems.

III. RATE PRIORITY OF RESEARCH ON THIS ISSUE AS IT RELATES TO AVIATION SAFETY.

/-----/-----X-----/-----/-----/  
EXTREMELY HIGH MODERATE LOW EXTREMELY  
HIGH LOW

IV. SUPPLEMENTARY INFORMATION.

A. EVIDENCE FOR IMPORTANCE OF ISSUES:

B. FUTURE RESEARCH PROJECTS NEEDED REGARDING THIS ISSUE:

C. APPLICATION OF FINDINGS - SAFETY, EFFICIENCY, AND/OR COST BENEFITS EXPECTED FROM FUTURE RESEARCH ON THIS ISSUE:

D. REFERENCES:

E. (OPTIONAL) PARTICIPANT NAME:-----

IDENTIFICATION OF HUMAN FACTORS ISSUES IN AVIATION:  
BIOMEDICAL AND BEHAVIORAL FACTORS

I. TITLE OF ISSUE OR QUESTION:

Research on various man-machine combinations to determine optimal future systems.

II. SUMMARY OF ISSUE OR QUESTION:

III. RATE PRIORITY OF RESEARCH ON THIS ISSUE AS IT RELATES TO AVIATION SAFETY.

/-----/-----/-----X-----/-----/  
EXTREMELY HIGH      HIGH      MODERATE      LOW      EXTREMELY LOW

IV. SUPPLEMENTARY INFORMATION.

A. EVIDENCE FOR IMPORTANCE OF ISSUES:

B. FUTURE RESEARCH PROJECTS NEEDED REGARDING THIS ISSUE:

C. APPLICATION OF FINDINGS - SAFETY, EFFICIENCY, AND/OR COST BENEFITS EXPECTED FROM FUTURE RESEARCH ON THIS ISSUE:

D. REFERENCES:

E. (OPTIONAL) PARTICIPANT NAME:-----

IDENTIFICATION OF HUMAN FACTORS ISSUES IN AVIATION:  
BIOMEDICAL AND BEHAVIORAL FACTORS

I. TITLE OF ISSUE OR QUESTION:

What impact does X-Ray emission from CRT have on the neurology system?

II. SUMMARY OF ISSUE OR QUESTION:

With increased use of high intensity and color CRT or the use of high voltase, what effect will this have on the decision making capability of the controller?

III. RATE PRIORITY OF RESEARCH ON THIS ISSUE AS IT RELATES TO AVIATION SAFETY.

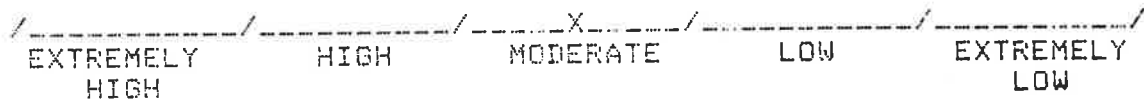

IV. SUPPLEMENTARY INFORMATION.

A. EVIDENCE FOR IMPORTANCE OF ISSUES:

B. FUTURE RESEARCH PROJECTS NEEDED REGARDING THIS ISSUE:

C. APPLICATION OF FINDINGS - SAFETY, EFFICIENCY, AND/OR COST BENEFITS EXPECTED FROM FUTURE RESEARCH ON THIS ISSUE:

Safety

D. REFERENCES:

E. (OPTIONAL) PARTICIPANT NAME:-----

IDENTIFICATION OF HUMAN FACTORS ISSUES IN AVIATION:  
BIOMEDICAL AND BEHAVIORAL FACTORS

I. TITLE OF ISSUE OR QUESTION:

Task analysis

II. SUMMARY OF ISSUE OR QUESTION:

With the projected use of humans in the decision making process for ATC, data bases need to be developed to assist in the selection process, and in the man-machine relationship.

III. RATE PRIORITY OF RESEARCH ON THIS ISSUE AS IT RELATES TO AVIATION SAFETY.

/-----X-----/-----/-----/-----/-----/  
EXTREMELY HIGH      HIGH      MODERATE      LOW      EXTREMELY LOW

IV. SUPPLEMENTARY INFORMATION.

A. EVIDENCE FOR IMPORTANCE OF ISSUES:

The future equipment development is directed towards providing more information to the controller.

B. FUTURE RESEARCH PROJECTS NEEDED REGARDING THIS ISSUE:

C. APPLICATION OF FINDINGS - SAFETY, EFFICIENCY, AND/OR COST BENEFITS EXPECTED FROM FUTURE RESEARCH ON THIS ISSUE:

safety

D. REFERENCES:

Tuckers, Kinney, Buckley

E. (OPTIONAL) PARTICIPANT NAME:\_\_\_\_\_

IDENTIFICATION OF HUMAN FACTORS ISSUES IN AVIATION:  
BIOMEDICAL AND BEHAVIORAL FACTORS

I. TITLE OF ISSUE OR QUESTION:

How to develop techniques that will allow determination of optimal levels of ATC automation

II. SUMMARY OF ISSUE OR QUESTION:

III. RATE PRIORITY OF RESEARCH ON THIS ISSUE AS IT RELATES TO AVIATION SAFETY.

/-----/-----X-----/-----/-----/  
EXTREMELY HIGH      HIGH      MODERATE      LOW      EXTREMELY LOW

IV. SUPPLEMENTARY INFORMATION.

A. EVIDENCE FOR IMPORTANCE OF ISSUES:

B. FUTURE RESEARCH PROJECTS NEEDED REGARDING THIS ISSUE:

C. APPLICATION OF FINDINGS - SAFETY, EFFICIENCY, AND/OR COST BENEFITS EXPECTED FROM FUTURE RESEARCH ON THIS ISSUE:

D. REFERENCES:

E. (OPTIONAL) PARTICIPANT NAME:-----

IDENTIFICATION OF HUMAN FACTORS ISSUES IN AVIATION:  
BIOMEDICAL AND BEHAVIORAL FACTORS

I. TITLE OF ISSUE OR QUESTION:

Task analyses, system error studies need to be conducted not on a one-time basis, but should be continually up-dated as ATC systems continue to evolve.

II. SUMMARY OF ISSUE OR QUESTION:

III. RATE PRIORITY OF RESEARCH ON THIS ISSUE AS IT RELATES TO AVIATION SAFETY.

/-----/-----X-----/-----/-----/-----/  
EXTREMELY HIGH      HIGH      MODERATE      LOW      EXTREMELY LOW

IV. SUPPLEMENTARY INFORMATION.

A. EVIDENCE FOR IMPORTANCE OF ISSUES:

B. FUTURE RESEARCH PROJECTS NEEDED REGARDING THIS ISSUE:

C. APPLICATION OF FINDINGS - SAFETY, EFFICIENCY, AND/OR COST BENEFITS EXPECTED FROM FUTURE RESEARCH ON THIS ISSUE:

D. REFERENCES:

E. (OPTIONAL) PARTICIPANT NAME:-----



IDENTIFICATION OF HUMAN FACTORS ISSUES IN AVIATION:  
BIOMEDICAL AND BEHAVIORAL FACTORS

I. TITLE OF ISSUE OR QUESTION:

human factors for ATCS

II. SUMMARY OF ISSUE OR QUESTION:

Definition of man/machine interface for proposed new ATC concepts such as CAS, MLS, M&S, CDTI. Also definition of new pilot/controller interface procedures.

III. RATE PRIORITY OF RESEARCH ON THIS ISSUE AS IT RELATES TO AVIATION SAFETY.

/-----/-----X/X-----/-----/  
EXTREMELY HIGH      HIGH      MODERATE      LOW      EXTREMELY LOW

IV. SUPPLEMENTARY INFORMATION.

A. EVIDENCE FOR IMPORTANCE OF ISSUES:

If these interfaces are not defined, the concepts often don't get used & they are needed, particularly CAS

B. FUTURE RESEARCH PROJECTS NEEDED REGARDING THIS ISSUE:

Experiments of ATC simulations of new concepts (esp. MLS & CDTI) to determine the best controller interfaces.

C. APPLICATION OF FINDINGS - SAFETY, EFFICIENCY, AND/OR COST BENEFITS EXPECTED FROM FUTURE RESEARCH ON THIS ISSUE:

D. REFERENCES:

E. (OPTIONAL) PARTICIPANT NAME: Messie Jennings

IDENTIFICATION OF HUMAN FACTORS ISSUES IN AVIATION:  
BIOMEDICAL AND BEHAVIORAL FACTORS

I. TITLE OF ISSUE OR QUESTION:

Relationship of classes of feedback to job satisfaction/  
dissatisfaction

II. SUMMARY OF ISSUE OR QUESTION:

Feedback from the job may be largely adverse based on policies.  
Many opportunities and data for positive feedback are available  
but unused.

III. RATE PRIORITY OF RESEARCH ON THIS ISSUE AS IT RELATES TO  
AVIATION SAFETY.

/-----X-----/-----/-----/-----/-----/  
EXTREMELY HIGH      HIGH      MODERATE      LOW      EXTREMELY LOW

IV. SUPPLEMENTARY INFORMATION.

A. EVIDENCE FOR IMPORTANCE OF ISSUES:

Dr. Rosen's studies and controller reports

B. FUTURE RESEARCH PROJECTS NEEDED REGARDING THIS ISSUE:

1. Study of means of combining feedback data to provide  
sources for positive feedback.

C. APPLICATION OF FINDINGS - SAFETY, EFFICIENCY, AND/OR COST  
BENEFITS EXPECTED FROM FUTURE RESEARCH ON THIS ISSUE:

Supervisor performance, on the job training, promotion  
and retention, selection.

D. REFERENCES:

E. (OPTIONAL) PARTICIPANT NAME: Joseph A. Tucker

IDENTIFICATION OF HUMAN FACTORS ISSUES IN AVIATION:  
BIOMEDICAL AND BEHAVIORAL FACTORS

I. TITLE OF ISSUE OR QUESTION:

Analysis of cognitive functions of Air Traffic Control.

II. SUMMARY OF ISSUE OR QUESTION:

The issue relates to understanding what "masters" performance by the controller really is.

III. RATE PRIORITY OF RESEARCH ON THIS ISSUE AS IT RELATES TO AVIATION SAFETY.

/-----/-----X-----/-----/-----/  
EXTREMELY HIGH      HIGH      MODERATE      LOW      EXTREMELY LOW

IV. SUPPLEMENTARY INFORMATION.

A. EVIDENCE FOR IMPORTANCE OF ISSUES:

Inability to specify what makes a top quality controller good in performance terms

B. FUTURE RESEARCH PROJECTS NEEDED REGARDING THIS ISSUE:

Development of embryonic methodologies

C. APPLICATION OF FINDINGS - SAFETY, EFFICIENCY, AND/OR COST BENEFITS EXPECTED FROM FUTURE RESEARCH ON THIS ISSUE:

Selection, training performance assessment

D. REFERENCES:

Office of Aviation Medicine work

E. (OPTIONAL) PARTICIPANT NAME: Joseph A. Tucker

IDENTIFICATION OF HUMAN FACTORS ISSUES IN AVIATION;  
BIOMEDICAL AND BEHAVIORAL FACTORS

I. TITLE OF ISSUE OR QUESTION:

Voice input

II. SUMMARY OF ISSUE OR QUESTION:

Can flight plan or clearance information be translated to computer language with important consequent reduction in ATCS button pushing?

III. RATE PRIORITY OF RESEARCH ON THIS ISSUE AS IT RELATES TO AVIATION SAFETY.

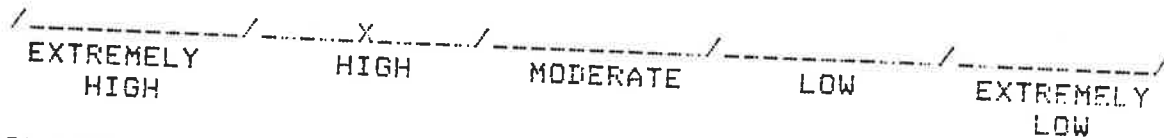

IV. SUPPLEMENTARY INFORMATION.

A. EVIDENCE FOR IMPORTANCE OF ISSUES:

High ATCS workload and distraction from monitoring situation display

B. FUTURE RESEARCH PROJECTS NEEDED REGARDING THIS ISSUE:

yes

C. APPLICATION OF FINDINGS - SAFETY, EFFICIENCY, AND/OR COST BENEFITS EXPECTED FROM FUTURE RESEARCH ON THIS ISSUE:

Increased system capacity is possible

D. REFERENCES:

D. W. Connolly Study at FAA TC showed some initial potential.

E. (OPTIONAL) PARTICIPANT NAME: \_\_\_\_\_

IDENTIFICATION OF HUMAN FACTORS ISSUES IN AVIATION:  
BIOMEDICAL AND BEHAVIORAL FACTORS

I. TITLE OF ISSUE OR QUESTION:

Impact of color displays on the ATC personnel system.

II. SUMMARY OF ISSUE OR QUESTION:

Many waivers have been granted for deficiencies in color vision. Possible increase in system errors by those who are deficient. Operational requirements/functional purposes need clearer definition.

III. RATE PRIORITY OF RESEARCH ON THIS ISSUE AS IT RELATES TO AVIATION SAFETY.

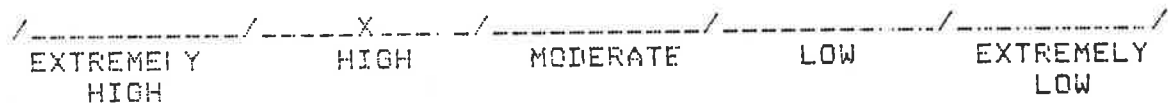

IV. SUPPLEMENTARY INFORMATION.

A. EVIDENCE FOR IMPORTANCE OF ISSUES:

Color displays being tested without regard for this issue.

B. FUTURE RESEARCH PROJECTS NEEDED REGARDING THIS ISSUE:

Monitor direction of design and functional application of color in tomorrow's system. Test optimum configuration for man and hardware.

C. APPLICATION OF FINDINGS - SAFETY, EFFICIENCY, AND/OR COST BENEFITS EXPECTED FROM FUTURE RESEARCH ON THIS ISSUE:

D. REFERENCES:

E. (OPTIONAL) PARTICIPANT NAME: E. W. Pickrel

IDENTIFICATION OF HUMAN FACTORS ISSUES IN AVIATION;  
BIOMEDICAL AND BEHAVIORAL FACTORS

I. TITLE OF ISSUE OR QUESTION:

Sector suite design

II. SUMMARY OF ISSUE OR QUESTION:

What is the optimum configuration of the enroute ATC sector?

III. RATE PRIORITY OF RESEARCH ON THIS ISSUE AS IT RELATES TO AVIATION SAFETY.

/-----/-----X-----/-----/-----/-----/  
EXTREMELY HIGH      HIGH      MODERATE      LOW      EXTREMELY LOW

IV. SUPPLEMENTARY INFORMATION.

A. EVIDENCE FOR IMPORTANCE OF ISSUES:

Computer driven system does not require the 36" flat row console arrangement. IBM deformagraphic display technology can eliminate heat generating and implosive potential CRT's and associated equipment from the control room - remote the hardware.

B. FUTURE RESEARCH PROJECTS NEEDED REGARDING THIS ISSUE:

C. APPLICATION OF FINDINGS - SAFETY, EFFICIENCY, AND/OR COST BENEFITS EXPECTED FROM FUTURE RESEARCH ON THIS ISSUE:

Increased flexibility for separate reconfiguration  
Environmental improvement, etc.

D. REFERENCES:

E. (OPTIONAL) PARTICIPANT NAME:-----

IDENTIFICATION OF HUMAN FACTORS ISSUES IN AVIATION:  
BIOMEDICAL AND BEHAVIORAL FACTORS

I. TITLE OF ISSUE OR QUESTION:

Determine the factors related to system errors, both individual and system.

II. SUMMARY OF ISSUE OR QUESTION:

Additional reformation is needed to determine the elements of the controller's performance that make him more or less susceptible to developing an error. Research in this area has been limited to only a few studies at this time.

III. RATE PRIORITY OF RESEARCH ON THIS ISSUE AS IT RELATES TO AVIATION SAFETY.

/-----/-----X-----/-----/-----/  
EXTREMELY HIGH      HIGH      MODERATE      LOW      EXTREMELY LOW

IV. SUPPLEMENTARY INFORMATION.

A. EVIDENCE FOR IMPORTANCE OF ISSUES:

B. FUTURE RESEARCH PROJECTS NEEDED REGARDING THIS ISSUE:

C. APPLICATION OF FINDINGS - SAFETY, EFFICIENCY, AND/OR COST BENEFITS EXPECTED FROM FUTURE RESEARCH ON THIS ISSUE:

D. REFERENCES:

E. (OPTIONAL) PARTICIPANT NAME:-----

IDENTIFICATION OF HUMAN FACTORS ISSUES IN AVIATION;  
BIOMEDICAL AND BEHAVIORAL FACTORS

I. TITLE OF ISSUE OR QUESTION:

Develop a skill analysis of the ATC Job.

II. SUMMARY OF ISSUE OR QUESTION:

This is needed to adequately assess the elements of the Job that are critical. It will serve as a data base for future evaluation and proposed changes.

III. RATE PRIORITY OF RESEARCH ON THIS ISSUE AS IT RELATES TO AVIATION SAFETY.

/-----X-----/-----/-----/-----/-----/  
EXTREMELY HIGH      HIGH      MODERATE      LOW      EXTREMELY LOW

IV. SUPPLEMENTARY INFORMATION.

A. EVIDENCE FOR IMPORTANCE OF ISSUES:

B. FUTURE RESEARCH PROJECTS NEEDED REGARDING THIS ISSUE:

C. APPLICATION OF FINDINGS - SAFETY, EFFICIENCY, AND/OR COST BENEFITS EXPECTED FROM FUTURE RESEARCH ON THIS ISSUE:

D. REFERENCES:

E. (OPTIONAL) PARTICIPANT NAME:-----



IDENTIFICATION OF HUMAN FACTORS ISSUES IN AVIATION:  
BIOMEDICAL AND BEHAVIORAL FACTORS

I. TITLE OF ISSUE OR QUESTION:

Evaluation of system improvements or alterations

II. SUMMARY OF ISSUE OR QUESTION:

When alterations are proposed, human factors studies are needed to assess the effects of these changes.

III. RATE PRIORITY OF RESEARCH ON THIS ISSUE AS IT RELATES TO AVIATION SAFETY.

/-----/-----X-----/-----/-----/  
EXTREMELY HIGH      HIGH      MODERATE      LOW      EXTREMELY LOW  
HIGH

IV. SUPPLEMENTARY INFORMATION.

A. EVIDENCE FOR IMPORTANCE OF ISSUES:

B. FUTURE RESEARCH PROJECTS NEEDED REGARDING THIS ISSUE:

C. APPLICATION OF FINDINGS - SAFETY, EFFICIENCY, AND/OR COST BENEFITS EXPECTED FROM FUTURE RESEARCH ON THIS ISSUE:

D. REFERENCES:

E. (OPTIONAL) PARTICIPANT NAME: \_\_\_\_\_

IDENTIFICATION OF HUMAN FACTORS ISSUES IN AVIATION;  
BIOMEDICAL AND BEHAVIORAL FACTORS

I. TITLE OF ISSUE OR QUESTION:

Lack of clear and documented understanding of controller skills and knowledge requirements.

II. SUMMARY OF ISSUE OR QUESTION:

Information is required to provide a baseline for change as job requirements are changed and for developing and validating controller selection criteria.

III. RATE PRIORITY OF RESEARCH ON THIS ISSUE AS IT RELATES TO AVIATION SAFETY.

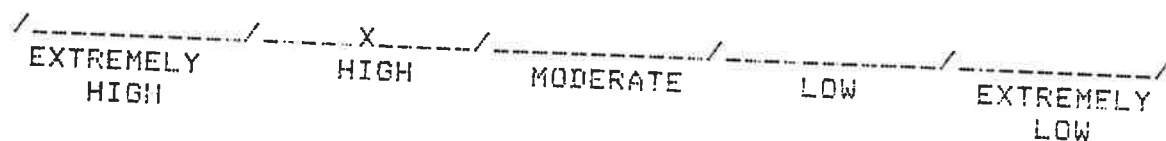

IV. SUPPLEMENTARY INFORMATION.

A. EVIDENCE FOR IMPORTANCE OF ISSUES:

B. FUTURE RESEARCH PROJECTS NEEDED REGARDING THIS ISSUE:

C. APPLICATION OF FINDINGS - SAFETY, EFFICIENCY, AND/OR COST BENEFITS EXPECTED FROM FUTURE RESEARCH ON THIS ISSUE:

D. REFERENCES:

E. (OPTIONAL) PARTICIPANT NAME: \_\_\_\_\_

IDENTIFICATION OF HUMAN FACTORS ISSUES IN AVIATION:  
BIOMEDICAL AND BEHAVIORAL FACTORS

I. TITLE OF ISSUE OR QUESTION:

ATCS Training

II. SUMMARY OF ISSUE OR QUESTION:

The FAA up or out program eliminates persons from ATCS jobs who are not able to perform at top level facilities. Research should be done to determine if the FAA is eliminating persons who could competently perform at lower levels.

III. RATE PRIORITY OF RESEARCH ON THIS ISSUE AS IT RELATES TO AVIATION SAFETY.

/-----/-----X-----/-----/-----/  
EXTREMELY HIGH      HIGH      MODERATE      LOW      EXTREMELY LOW

IV. SUPPLEMENTARY INFORMATION.

A. EVIDENCE FOR IMPORTANCE OF ISSUES:

High attrition in ATCS training failure

B. FUTURE RESEARCH PROJECTS NEEDED REGARDING THIS ISSUE:

C. APPLICATION OF FINDINGS - SAFETY, EFFICIENCY, AND/OR COST BENEFITS EXPECTED FROM FUTURE RESEARCH ON THIS ISSUE:

Cost beneficial if competent persons are not separated.

D. REFERENCES:

E. (OPTIONAL) PARTICIPANT NAME: Jim Boone, Ph.D.

IDENTIFICATION OF HUMAN FACTORS ISSUES IN AVIATION;  
BIOMEDICAL AND BEHAVIORAL FACTORS

I. TITLE OF ISSUE OR QUESTION:

ATCS training

II. SUMMARY OF ISSUE OR QUESTION:

Use of automation to compress ATCS training time.

III. RATE PRIORITY OF RESEARCH ON THIS ISSUE AS IT RELATES TO AVIATION SAFETY.

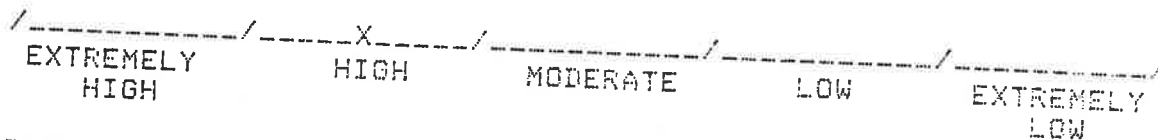

IV. SUPPLEMENTARY INFORMATION.

A. EVIDENCE FOR IMPORTANCE OF ISSUES:

Present ATCS training methods require large manpower from the active ATCS workforce and is a slow and ineffcient process.

B. FUTURE RESEARCH PROJECTS NEEDED REGARDING THIS ISSUE:

C. APPLICATION OF FINDINGS - SAFETY, EFFICIENCY, AND/OR COST BENEFITS EXPECTED FROM FUTURE RESEARCH ON THIS ISSUE:

Better method to fill the ATCS personnel shortfall and maintain active ATCS for job tasks rather than training.

D. REFERENCES:

E. (OPTIONAL) PARTICIPANT NAME: Jim Boche, Ph.D.

QUESTIONNAIRES DISTRIBUTED IN WORKSHOP C, CABIN SAFETY

IDENTIFICATION OF HUMAN FACTORS ISSUES IN AVIATION:  
BIOMEDICAL AND BEHAVIORAL FACTORS

I. TITLE OF ISSUE OR QUESTION:

Survival in unplanned crash landings in water.

II. SUMMARY OF ISSUE OR QUESTION:

What equipment is needed to assure survival, considering promptness of rescue, water temperature, etc. When should such a crash landing be considered a significant threat (ie: size & location of body of water, etc).

III. RATE PRIORITY OF RESEARCH ON THIS ISSUE AS IT RELATES TO AVIATION SAFETY.

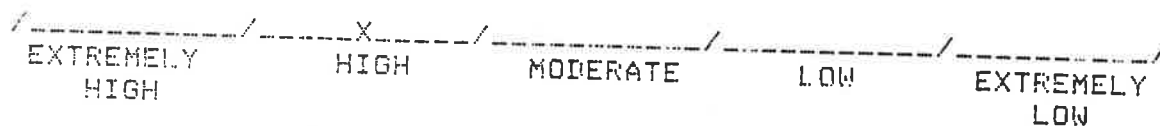

IV. SUPPLEMENTARY INFORMATION.

A. EVIDENCE FOR IMPORTANCE OF ISSUES:

Hypothermia, drownings

B. FUTURE RESEARCH PROJECTS NEEDED REGARDING THIS ISSUE:

open

C. APPLICATION OF FINDINGS - SAFETY, EFFICIENCY, AND/OR COST BENEFITS EXPECTED FROM FUTURE RESEARCH ON THIS ISSUE:

D. REFERENCES:

E. (OPTIONAL) PARTICIPANT NAME: Henri Brantins FAA ASW-120

IDENTIFICATION OF HUMAN FACTORS ISSUES IN AVIATION:  
BIOMEDICAL AND BEHAVIORAL FACTORS

I. TITLE OF ISSUE OR QUESTION:

Cabin Pressurization

II. SUMMARY OF ISSUE OR QUESTION:

It is commonly believed that cabin pressure is equivalent to 5,000-6,000 ft. altitude. Many times it can be on the order of 10,000 ft. The public and medical profession is unaware of this sometimes dangerously rarified atmosphere that can cause cardiac arrest or other cardiac and respiratory problems.

III. RATE PRIORITY OF RESEARCH ON THIS ISSUE AS IT RELATES TO AVIATION SAFETY.

/-----X-----/-----/-----/-----/-----/  
EXTREMELY HIGH      HIGH      MODERATE      LOW      EXTREMELY LOW

IV. SUPPLEMENTARY INFORMATION.

A. EVIDENCE FOR IMPORTANCE OF ISSUES:

See II. Saving fuel at the expense of public health and safety. Evidence is commonly available from the medical and aviation community.

B. FUTURE RESEARCH PROJECTS NEEDED REGARDING THIS ISSUE:

Public medical aviation statistics - data base to monitor health (cardio-pulmonary) effects of air travel on the public at large.

C. APPLICATION OF FINDINGS - SAFETY, EFFICIENCY, AND/OR COST BENEFITS EXPECTED FROM FUTURE RESEARCH ON THIS ISSUE:

To be determined - definitely in the public interest

D. REFERENCES:

FAA Docket 20351

E. (OPTIONAL) PARTICIPANT NAME:-----

IDENTIFICATION OF HUMAN FACTORS ISSUES IN AVIATION:  
BIOMEDICAL AND BEHAVIORAL FACTORS

I. TITLE OF ISSUE OR QUESTION:

Toxic fume protection for occupants of passenger cabin

II. SUMMARY OF ISSUE OR QUESTION:

There is no protective breathing equipment against toxic fumes.

III. RATE PRIORITY OF RESEARCH ON THIS ISSUE AS IT RELATES TO AVIATION SAFETY.

/-----X-----/-----/-----/-----/-----/  
EXTREMELY HIGH      HIGH      MODERATE      LOW      EXTREMELY LOW  
HIGH

IV. SUPPLEMENTARY INFORMATION.

A. EVIDENCE FOR IMPORTANCE OF ISSUES:

It appears approximately 600 people have been asphyxiated over the last 24 months (mostly on American made aircraft) The aviation industry is facing an MGM disaster every few months and is doing little or nothing about it.

B. FUTURE RESEARCH PROJECTS NEEDED REGARDING THIS ISSUE:

C. APPLICATION OF FINDINGS - SAFETY, EFFICIENCY, AND/OR COST BENEFITS EXPECTED FROM FUTURE RESEARCH ON THIS ISSUE:

Industry credibility

D. REFERENCES:

FAA Docket 20331, News Articles, Common Knowledge

E. (OPTIONAL) PARTICIPANT NAME:-----



IDENTIFICATION OF HUMAN FACTORS ISSUES IN AVIATION:  
BIOMEDICAL AND BEHAVIORAL FACTORS

I. TITLE OF ISSUE OR QUESTION:

Fresh air ventilation bacteriological, viral and fungal contamination limits (also toxic gas contamination limits).

II. SUMMARY OF ISSUE OR QUESTION:

Fresh air ventilation is dangerously low (from a health standpoint). The low fresh air ventilation rates is promoting the spread of contagious diseases.

III. RATE PRIORITY OF RESEARCH ON THIS ISSUE AS IT RELATES TO AVIATION SAFETY.

/-----X-----/-----/-----/-----/-----/  
EXTREMELY HIGH      HIGH      MODERATE      LOW      EXTREMELY LOW

IV. SUPPLEMENTARY INFORMATION.

A. EVIDENCE FOR IMPORTANCE OF ISSUES:

FAA Docket 20351

B. FUTURE RESEARCH PROJECTS NEEDED REGARDING THIS ISSUE:

Numerous, which should be apparent after reviewing FAA Docket 20351

C. APPLICATION OF FINDINGS - SAFETY, EFFICIENCY, AND/OR COST BENEFITS EXPECTED FROM FUTURE RESEARCH ON THIS ISSUE:

Substantial, lost benefits.

D. REFERENCES:

FAA Docket 20351

E. (OPTIONAL) PARTICIPANT NAME:-----

IDENTIFICATION OF HUMAN FACTORS ISSUES IN AVIATION:  
BIOMEDICAL AND BEHAVIORAL FACTORS

I. TITLE OF ISSUE OR QUESTION:

Cold water survival - aircraft accidents.

II. SUMMARY OF ISSUE OR QUESTION:

Acquisition and donning of personal flotation devices - can certain types of life preservers be donned by typical aircraft passengers with less confusion and in less time - are certain life preserver storage locations more accessible during emergencies (seat back vs underseat storage).

III. RATE PRIORITY OF RESEARCH ON THIS ISSUE AS IT RELATES TO AVIATION SAFETY.

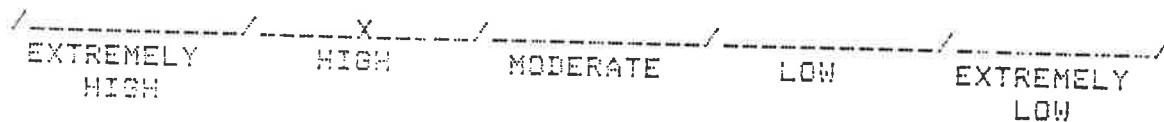

IV. SUPPLEMENTARY INFORMATION.

A. EVIDENCE FOR IMPORTANCE OF ISSUES:

St. Croix, Escambia Bay and Shetland Islands accidents

B. FUTURE RESEARCH PROJECTS NEEDED REGARDING THIS ISSUE:

Acquisition of personal flotation devices

C. APPLICATION OF FINDINGS - SAFETY, EFFICIENCY, AND/OR COST BENEFITS EXPECTED FROM FUTURE RESEARCH ON THIS ISSUE:

D. REFERENCES:

NTSB and English reports

E. (OPTIONAL) PARTICIPANT NAME: Do. de Steigler, AAC-119D

IDENTIFICATION OF HUMAN FACTORS ISSUES IN AVIATION:  
BIOMEDICAL AND BEHAVIORAL FACTORS

I. TITLE OF ISSUE OR QUESTION:

Protective breathing devices for flightcrew members

II. SUMMARY OF ISSUE OR QUESTION:

Tests conducted at CAMI demonstrate problems with the efficiency of current-use protective breathing devices and also demonstrate solutions (with minimal economic impact) for these problems.

III. RATE PRIORITY OF RESEARCH ON THIS ISSUE AS IT RELATES TO AVIATION SAFETY.

/-----X-----/-----/-----/-----/-----/  
EXTREMELY HIGH      HIGH      MODERATE      LOW      EXTREMELY LOW

IV. SUPPLEMENTARY INFORMATION.

A. EVIDENCE FOR IMPORTANCE OF ISSUES:

Boston Pan Am accident, November, 1973.

B. FUTURE RESEARCH PROJECTS NEEDED REGARDING THIS ISSUE:

Positive action by the FAA to upgrade protective breathing devices.

C. APPLICATION OF FINDINGS - SAFETY, EFFICIENCY, AND/OR COST BENEFITS EXPECTED FROM FUTURE RESEARCH ON THIS ISSUE:

D. REFERENCES:

FAA-AM-78-4

E. (OPTIONAL) PARTICIPANT NAME: Don de Steisuer, AAC-119D

IDENTIFICATION OF HUMAN FACTORS ISSUES IN AVIATION:  
BIOMEDICAL AND BEHAVIORAL FACTORS

I. TITLE OF ISSUE OR QUESTION:

In-flight fires

II. SUMMARY OF ISSUE OR QUESTION:

Examine the concept and operational procedures for intentional decompression during in-flight fires as a means to activate the passenger oxygen system, providing some respiratory protection from toxic fumes produced by the fire.

III. RATE PRIORITY OF RESEARCH ON THIS ISSUE AS IT RELATES TO AVIATION SAFETY.

/-----/-----X-----/-----/-----/  
EXTREMELY HIGH      HIGH      MODERATE      LOW      EXTREMELY LOW

IV. SUPPLEMENTARY INFORMATION.

A. EVIDENCE FOR IMPORTANCE OF ISSUES:

Varig and Saudi in-flight fires

B. FUTURE RESEARCH PROJECTS NEEDED REGARDING THIS ISSUE:

Passenger respiratory protection from in-flight toxic fumes.

C. APPLICATION OF FINDINGS - SAFETY, EFFICIENCY, AND/OR COST BENEFITS EXPECTED FROM FUTURE RESEARCH ON THIS ISSUE:

D. REFERENCES:

E. (OPTIONAL) PARTICIPANT NAME: Don de Steiguer, AAC-119D

IDENTIFICATION OF HUMAN FACTORS ISSUES IN AVIATION:  
BIOMEDICAL AND BEHAVIORAL FACTORS

I. TITLE OF ISSUE OR QUESTION:

Is research as applicable as possible and are research findings available to operational people?

II. SUMMARY OF ISSUE OR QUESTION:

Many times people who have to use equipment or procedures developed in research have little input into what is being researched. In addition, research findings are not readily accessible or easily understood by these operational people.

III. RATE PRIORITY OF RESEARCH ON THIS ISSUE AS IT RELATES TO AVIATION SAFETY.

/-----/-----X-----/-----/-----/-----/  
EXTREMELY HIGH            HIGH            MODERATE            LOW            EXTREMELY LOW

IV. SUPPLEMENTARY INFORMATION.

A. EVIDENCE FOR IMPORTANCE OF ISSUES:

There is misunderstanding of use of O2 equipment, brace for impact positions, and implications of seat design. This is also evidenced by popularity of protection and survival workshops conducted by AAC-119 for operational people, request for information, etc.

B. FUTURE RESEARCH PROJECTS NEEDED REGARDING THIS ISSUE:

Analysis of incidents/accidents/inspector reports are needed to provide up-to-date information regarding cabin discrepancies and operational problems.

C. APPLICATION OF FINDINGS - SAFETY, EFFICIENCY, AND/OR COST BENEFITS EXPECTED FROM FUTURE RESEARCH ON THIS ISSUE:

Identification of actual safety problems and trends in order to make research meaningful and applicable will be cost beneficial, enabling airlines to make use of researcher materials helps make training more cost beneficial and meaningful.

D. REFERENCES:

E. (OPTIONAL) PARTICIPANT NAME: Donell Pollard

IDENTIFICATION OF HUMAN FACTORS ISSUES IN AVIATION: BIOMEDICAL AND BEHAVIORAL FACTORS:

I. Title of Issue or question:  
Crash Injury Potential of Seat/Restraint Systems.

II. Summary of Issue or question:  
Seats/restraint systems are presently tested statistically. This is an outmoded method and provides very little information about crash injury. Testing needs to continue to discover and establish parameters to be used for dynamically testing seats/restraints for certification for use in air craft.

III. Rate priority of research on this issue as it relates to aviation safety.

/    XXX    /            /            /

---

Extremely    High            Moderate            Low            Extremely low  
High

IV. Supplementary information.

- A. Evidence for importance of issues:  
Cabin Safety Data Bank, Accident History and sled test research indicate that many times there is little correlation between strength as statistically determined and actual performance in crash situations, especially pertinent to injury causation. In addition, dynamic testing might make possible use of flexible, lighter weight materials thus reducing the weight penalty imposed by seats.
- B. Future research projects needed regarding this issue:  
Continuation and additional emphasis.

C. Application of Findings - Safety, efficiency, and/or cost benefits expected from future research on this issue:

See A, reduction of weight.

D. References:

E. (Optional) Participant name: Donell Pollard

Please return by Aug 9, 1981

TO: Dr. Henry W. Mertens  
FAA/CAMI, AAC-118  
P.O. Box 25082  
Oklahoma City, OK. 73125

IDENTIFICATION OF HUMAN FACTORS ISSUES IN AVIATION: BIOMEDICAL AND BEHAVIORAL FACTORS:

I. Title of Issue or question:

What are the variables which influence passenger egress.

II. Summary of Issue or question:

Further study needs to be conducted to ascertain the effects of such things as lighting, cabin debris, aisle width, seat pitch on evacuations under emergency conditions.

III. Rate priority of research on this issue as it relates to aviation safety.

\_\_\_\_\_ / \_\_\_\_\_ / XXX / \_\_\_\_\_ / \_\_\_\_\_  
Extremely High Moderate Low Extremely low  
High

IV. Supplementary information.

A. Evidence for importance of issues:

Evidence in Cabin Safety Data Bank, Accident Histories that many variables may influence passenger egress.

B. Future research projects needed regarding this issue:

Extension of present research findings.

C. Application of Findings - Safety, efficiency, and/or cost benefits expected from future research on this issue:

Possibly advancing time when computer modeling could be used for aircraft certification.

D. References:

E. (Optional) Participant name: Donell Pollard

Please return by Aug 9, 1981

TO: Dr. Henry W. Mertens  
FAA/CAMI, AAC-118  
P.O. Box 25082  
Oklahoma City, OK. 73125

QUESTIONNAIRES DISTRIBUTED IN WORKSHOP D, MEDICAL ASPECTS OF AIRCRAFT  
ACCIDENT INVESTIGATION



IDENTIFICATION OF HUMAN FACTORS ISSUES IN AVIATION:  
BIOMEDICAL AND BEHAVIORAL FACTORS

I. TITLE OF ISSUE OR QUESTION:

There is an urgent need for the development of a computer program package to facilitate the handling of mass casualty accidents.

II. SUMMARY OF ISSUE OR QUESTION:

Mass casualty accidents occur infrequently but when they happen the normal order of things is upset and many problems surface. There is no good, complete, computer program to address this problem in existence today. Insurance underwriters have verified the need for more expeditious methods of processing the casualties.

The use of a good computer program would:

- 1) Standardize antemortem data and act as a guide for airline personnel in the collection of such data.
- 2) Standardize the collection of postmortem data by Pathologists, Dentists, personal effects personnel, fingerprint experts, and other forensic scientists.
- 3) Facilitate the comparison of postmortem and antemortem data during the identification process.
- 4) Provide for the accumulation, storing, and verification of more toxicology and autopsy data during the autopsy process.
- 5) Simplify the Identification and separation of the remains of the crew of the airplane in a mass casualty accident.
- 6) Make it a simpler process to record the antemortem and postmortem seat locations.
- 7) Save money for it would shorten the time involved in the mass accident investigation process.

III. RATE PRIORITY OF RESEARCH ON THIS ISSUE AS IT RELATES TO AVIATION SAFETY.

/-----/-----X-----/-----/-----/  
EXTREMELY HIGH                  HIGH                  MODERATE                  LOW                  EXTREMELY LOW

IV. SUPPLEMENTARY INFORMATION.

A. EVIDENCE FOR IMPORTANCE OF ISSUES:

Insurance underwriters, Coroners, Medical Examiners, Forensic Dentists, and other Forensic Scientists verify that there is no good complete computer program of this type available for air or other modes of transportation accidents.

B. FUTURE RESEARCH PROJECTS NEEDED REGARDING THIS ISSUE:

We know of no Civilian or Military Program that has the completeness to carry out the desired functions. Data for the layout for such a program was cumulated at FAA's Civil Aeromedical Institute some years ago, but the computer program never came to fruition. The computer Identification assistance program could be obtained by contract with a computer programming company and selected forensic scientists familiar with the uniqueness of this type of data and the data comparison process. Forensic scientists familiar with mass casualty processing must be included. NTSB, and CAMI Human Factors personnel should field test the program to improve, modify, and update its content as needed.

C. APPLICATION OF FINDINGS - SAFETY, EFFICIENCY, AND/OR COST BENEFITS EXPECTED FROM FUTURE RESEARCH ON THIS ISSUE:

The general public would benefit for simplified techniques would be developed to assist the local Coroner or Medical examiner minimize misidentifications. When an accident occurs in a sparsely populated area the NTSB and the FAA would be in a better position to be of assistance to those at the scene. Bodies could be processed rapidly and returned to the bereaved sooner to help lessen their sorrow. The entire ID process could be handled more efficiently and costs reduced. When this type of program is utilized in a Commuter or Air Taxi accident the medical and toxicology information could be more completely documented.

D. REFERENCES:

Reports, discussions, and personal communications regarding Identification problems at the scene of mass casualty accidents that have occurred within the last five years identify the need for this type of a program.

E. Participant's Name: Curtis A. Mertz, D.D.S.

IDENTIFICATION OF HUMAN FACTORS ISSUES IN AVIATION:  
BIOMEDICAL AND BEHAVIORAL FACTORS

I. TITLE OF ISSUE OR QUESTION:

Post-crash mental care for aircraft accident survivors.

II. SUMMARY OF ISSUE OR QUESTION:

What are the needs of cockpit crew, cabin crew, and passengers for post-crash mental care in order to assess the emotional trauma, detect subsequent potentially adverse effects of the accident experience on personal performance (e.g., judgment, emotional response to emergencies, etc.), and treatment programs to promote recovery.

III. RATE PRIORITY OF RESEARCH ON THIS ISSUE AS IT RELATES TO AVIATION SAFETY.

/-----/-----X-----/-----/-----/  
EXTREMELY HIGH      HIGH      MODERATE      LOW      EXTREMELY LOW

IV. SUPPLEMENTARY INFORMATION.

A. EVIDENCE FOR IMPORTANCE OF ISSUES:

There is considerable evidence from the Tenerife KLM/Pan Am collision and the Western Air Lines accident in Mexico City that mental care of cabin crew and passengers is helpful in alleviating psychological trauma. Cockpit crews may also benefit from mental care following an accident. Two cases are known where airline pilots committed suicide following an accident.

B. FUTURE RESEARCH PROJECTS NEEDED REGARDING THIS ISSUE:

Research is needed to determine the scope of the problem, the effects of trauma on post-crash personal performance, and methods of dealing with post-crash mental effects.

C. APPLICATION OF FINDINGS - SAFETY, EFFICIENCY, AND/OR COST BENEFITS EXPECTED FROM FUTURE RESEARCH ON THIS ISSUE:

Mental care for accident survivors may enable more rapid relief from trauma in survivors and more rapid return to productive activity.

D. REFERENCES:

E. (OPTIONAL) PARTICIPANT NAME: Jerome Lederer

IDENTIFICATION OF HUMAN FACTORS ISSUES IN AVIATION: BIOMEDICAL AND BEHAVIORAL FACTORS:

- I. Title of Issue or question:  
 With decreasing numbers of military pilots in the civilian community because of long military retention of its pilots, will the GA accident rate increase?
- II. Summary of Issue or question:  
 Most airplane pilots and many commercial pilots have military backgrounds. Fewer pilots are leaving the services. Therefore, commercial and airline flying will rely more heavily on the available supply of civilian trained aviators. Will this have an unfavorable effect upon civilian accident rates?
- III. Rate priority of research on this issue as it relates to aviation safety.
- |                |      |          |     |               |
|----------------|------|----------|-----|---------------|
| /              | /    | X        | /   | /             |
| Extremely High | High | Moderate | Low | Extremely low |
- IV. Supplementary information.
- A. Evidence for importance of issues:  
 The evidence needs to be developed to see if this is or is not a problem.
- B. Future research projects needed regarding this issue:  
 An accident study is required to determine the efficiency of a military background in civilian accident prevention. If military trained pilots have a lower accident rate during a civilian career then something from the military training
- C. Application of Findings - Safety, efficiency, and/or cost benefits expected from future research on this issue:  
 Possibly lowered accident rates. should be included in the civilian training.
- D. References:
- E. (Optional) Participant name: \_\_\_\_\_

Please return by Aug 9, 1981

TO: Dr. Henry W. Mertens  
 FAA/CAMI, AAC-118  
 P.O. Box 25082  
 Oklahoma City, OK. 73125

IDENTIFICATION OF HUMAN FACTORS ISSUES IN AVIATION: BIOMEDICAL AND BEHAVIORAL FACTORS:

- I. Title of Issue or question:  
The Psychology of the Co-pilot Takeover from the Captain
- II. Summary of Issue or question:  
Apparently, too few pilots flying the airplane as co-pilot are willing to take over control even when the aircraft is evidently outside of acceptable parameters. The need for assertiveness has been made evident in a significant number of airplane accidents. In addition to the assertive training called for by the NTSB, another means may be developed to promote the takeover without loss of prestige by the Captain (of co-pilot, in some cases).
- III. Rate priority of research on this issue as it relates to aviation safety.

X / / / /  
Extremely High Moderate Low Extremely low  
High

IV. Supplementary information.

A. Evidence for importance of issues:

The accidents in Partland, Oregon, the accident in the Gulf of Mexico, and numerous other landing accidents are mute reminders of this need.

B. Future research projects needed regarding this issue:

Develop the approach path as a system with no prestige loss for the takeover of control by the non-flying pilot anytime the aircraft and approach system is out of rigidly preset limits.

C. Application of Findings - Safety, efficiency, and/or cost benefits expected from future research on this issue:

Accident prevention and loss of life speaks for itself.

D. References:

E. (Optional) Participant name: \_\_\_\_\_

Please return by Aug 9, 1981

TO: Dr. Henry W. Mertens  
FAA/CAMI, AAC-118  
P.O. Box 25082  
Oklahoma City, OK. 73125

IDENTIFICATION OF HUMAN FACTORS ISSUES IN AVIATION: BIOMEDICAL AND BEHAVIORAL FACTORS:

- I. Title of Issue or question:  
Airport Contribution to Accidents
- II. Summary of Issue or question:  
Epidemiological studies are needed of airports to determine which if any are implicated in accidents. Certain aspects seem to be so related. Over water takeoffs in light aircraft seems to be one such factor.
- III. Rate priority of research on this issue as it relates to aviation safety.
- |                |   |      |   |          |   |     |   |  |   |  |   |  |               |
|----------------|---|------|---|----------|---|-----|---|--|---|--|---|--|---------------|
| Extremely High | / | X    | / |          | / |     | / |  | / |  | / |  |               |
|                |   | High |   | Moderate |   | Low |   |  |   |  |   |  | Extremely low |
- IV. Supplementary information.
- A. Evidence for importance of issues:  
New Orleans Lakefront airport is notorious for disorientation accidents in G/A aircraft. Kansas City was a problem for air carriers landing short and striking the surrounding dykes. Some are a problem because of summer density altitudes.
- B. Future research projects needed regarding this issue:  
A long-term epidemiological study of all nations' airports is required. With proper factor analysis, the relation to accidents can be developed.
- C. Application of Findings - Safety, efficiency, and/or cost benefits expected from future research on this issue:  
The offending airports can be modified and others can benefit from the experience so gained. New airports can be designed without these traps in the development.
- D. References:  
Daugherty et al
- E. (Optional) Participant name: \_\_\_\_\_

Please return by Aug 9, 1981

TO: Dr. Henry W. Mertens  
FAA/CAMI, AAC-118  
P.O. Box 25082  
Oklahoma City, OK. 73125

IDENTIFICATION OF HUMAN FACTORS ISSUES IN AVIATION: BIOMEDICAL AND BEHAVIORAL FACTORS:

- I. Title of Issue or question:  
Who has what legal responsibilities at the scene of an accident?
  
- II. Summary of Issue or question:  
The answers to this question are reasonably well known, i.e. the NTSB has sole Federal responsibility. However, outside of Federal circles, the answers are seldom known. Most local and state authorities need to be made aware clearly of this fact and of the limitations placed on them in the case of an aircraft accident. Much valuable information is often lost by premature "do gooders" who inadvertently destroy information or muddle it which creates difficulty.
  
- III. Rate priority of research on this issue as it relates to aviation safety.

/	X	/	/	/
Extremely High	High	Moderate	Low	Extremely low

- IV. Supplementary information.
  - A. Evidence for importance of issues:  
Few, if any, coroners and medical examiners really understand that they do not have primary jurisdiction in the case of an aircraft accident. This has resulted in the destruction of valuable accident investigation information and even competition in some cases as to who can do what?
  
  - B. Future research projects needed regarding this issue:  
A publication detailing these responsibilities and actions should be sent to the coroners and medical examiners of every county in the U.S.A. The problem will not be solved but it can be minimized.
  
  - C. Application of Findings - Safety, efficiency, and/or cost benefits expected from future research on this issue:  
Ease and speed of accident investigation will be facilitated.
  
  
  - D. References:
  
  
  - E. (Optional) Participant name: \_\_\_\_\_

Please return by Aug 9, 1981  
  
TO: Dr. Henry W. Mertens  
FAA/CAMI, AAC-118  
P.O. Box 25082  
Oklahoma City, OK. 73125

IDENTIFICATION OF HUMAN FACTORS ISSUES IN AVIATION: BIOMEDICAL AND BEHAVIORAL FACTORS:

I. Title of Issue or question:

The Mass Casualty Problem

II. Summary of Issue or question:

No jurisdiction is really ready for mass casualties. This has been shown in New York, Chicago, San Diego, and Teneriffe. The experience of those involved should be collated and developed in to a planning guide. Just the logistical problems alone are staggering and not properly considered until too late. However, the experience is available if it can be drawn together.

III. Rate priority of research on this issue as it relates to aviation safety.

	/	/	X	/	/		
Extremely High			Moderate		Low		Extremely low

IV. Supplementary information.

A. Evidence for importance of issues:

No one is of the opinion that another mass casualty accident will never occur. It is only a matter of time. In that case, few airports are really ready in spite of periodic exercising of plans. Almost none have any plan for autopsies, body bags, stakes, reefers for body storage, x-rays for dental identification, etc. However, the requirements are known by those with the

B. Future research projects needed regarding this issue: experience.

A "literature" search should provide the information needed for such a guide. Admittedly, the market for such a guide is small but it is important.

C. Application of Findings - Safety, efficiency, and/or cost benefits expected from future research on this issue:

Expediency in gathering and organizing the supplies necessary can assist in minimizing costs of accident investigation.

D. References:

Kirkham, INA, Wick, etc.

E. (Optional) Participant name: \_\_\_\_\_

Please return by Aug 9, 1981

TO: Dr. Henry W. Mertens  
FAA/CAMI, AAC-118  
P.O. Box 25082  
Oklahoma City, OK. 73125



IDENTIFICATION OF HUMAN FACTORS ISSUES IN AVIATION: BIOMEDICAL AND BEHAVIORAL FACTORS:

I. Title of Issue or question:  
Passenger Identification Responsibilities: Moral, Ethical, Legal

II. Summary of Issue or question:  
In the last several mass disasters, the problem of passenger identification was extreme, acute in time pressure, and difficult technically. Can better organization and planning improve the problems which arose? In particular, should a coordinated plan be developed for cooperation between dental experts, fingerprint teams, personal effects teams, and anthropologists which might eliminate some confusion which is characteristic of such events?

III. Rate priority of research on this issue as it relates to aviation safety.

\_\_\_\_\_ / \_\_\_\_\_ / X / \_\_\_\_\_ / \_\_\_\_\_  
Extremely High Moderate Low Extremely low  
High

IV. Supplementary information.

A. Evidence for importance of issues:

Haste has been a problem which brought together separate elements of forensic teams which were therefore uncoordinated. Had a plan been in existence, the effort should have been quicker and with less duplication. This would have speeded identification process, saved time, and been less expensive and less traumatic to families.

B. Future research projects needed regarding this issue:

What organizational notification plan can be developed to integrate the identification elements?

C. Application of Findings - Safety, efficiency, and/or cost benefits expected from future research on this issue:

This is expected to ease the legal problems involved with major accidents as well as solve moral and ethical problems resulting from questionable presence on aircraft of deceased. Positive and quick identification eases all these problems.

D. References:

Kirkham et al

E. (Optional) Participant name: \_\_\_\_\_

Please return by Aug 9, 1981

TO: Dr. Henry W. Mertens  
FAA/CAMI, AAC-118  
P.O. Box 25082  
Oklahoma City, OK. 73125

IDENTIFICATION OF HUMAN FACTORS ISSUES IN AVIATION: BIOMEDICAL AND BEHAVIORAL FACTORS:

I. Title of Issue or question:  
The Use of Dental Records in Victim Identification

II. Summary of Issue or question:  
Aircraft accidents in which fire plays a major role present a significant problem in victim identification. Improved means of locating dental records quickly are needed. Aircrew members may well benefit by having Pannorex films on file at their bases.

III. Rate priority of research on this issue as it relates to aviation safety.

\_\_\_\_\_ / \_\_\_\_\_ / \_\_\_\_\_ /  X  / \_\_\_\_\_  
Extremely High Moderate Low Extremely low  
High

IV. Supplementary information.

A. Evidence for importance of issues:

This is not directly a safety prevention issue. However, it is relevant since location and identification of the crew member or members does play some role in accident investigation. Following a fire, the use of dental records is probably the single most helpful identification tool. It is in some cases the only means available.

B. Future research projects needed regarding this issue:

Should dental information be recorded on FAA records? Is this feasible?

C. Application of Findings - Safety, efficiency, and/or cost benefits expected from future research on this issue:

Considerable time can be saved during an accident investigation which permits prompt information about which tissue is that of crew. This in turn permits accurate information to be gleaned about presence or absence of other medical

D. References: factors (e.g. infarcts on part of pilots, etc.) found in crew remains.

Kirkham et al

E. (Optional) Participant name: \_\_\_\_\_

Please return by Aug 9, 1981

TO: Dr. Henry W. Mertens  
FAA/CAMI, AAC-118  
P.O. Box 25082  
Oklahoma City, OK. 73125

IDENTIFICATION OF HUMAN FACTORS ISSUES IN AVIATION: BIOMEDICAL AND BEHAVIORAL FACTORS:

I. Title of Issue or question:  
The Role of Alcohol and Other Drugs in Aircraft Accidents

II. Summary of Issue or question:  
While there is some probability regarding the role of alcohol in fatal and non-fatal accidents, this should be clarified. Equally important, the role of common street drugs and especially marijuana should be investigated.

III. Rate priority of research on this issue as it relates to aviation safety.

Extremely High / X / Moderate / Low / Extremely low

IV. Supplementary information.

A. Evidence for importance of issues:

Reports indicate that alcohol plays a role in from 8% to 50% of the fatal aircraft accidents. This wide variation should be pinned down. Unknown, however, is the role of common street drugs including the cannabis drug so popular at present.

B. Future research projects needed regarding this issue:

Easy method for determination of presence or use of cannabis.  
Representative sample of all accidents to determine rate of occurrence following alcohol and drug use.

C. Application of Findings - Safety, efficiency, and/or cost benefits expected from future research on this issue:

The cannabis work should have application in auto accidents as well as in aircraft. It may also have some relation to industrial accidents.

D. References:

Harper et al, Mohler et al, Wick et al in Aerospace Medicine. See Bill Collins for a good bibliography.

E. (Optional) Participant name: \_\_\_\_\_

Please return by Aug 9, 1981

TO: Dr. Henry W. Mertens  
FAA/CAMI, AAC-118  
P.O. Box 25082  
Oklahoma City, OK. 73125

IDENTIFICATION OF HUMAN FACTORS ISSUES IN AVIATION: BIOMEDICAL AND BEHAVIORAL FACTORS:

I. Title of Issue or question:  
Shoulder Harness Use in Commuter and G/A Aircraft

II. Summary of Issue or question:  
There are numerous anecdotal reports of individuals injured in crashes in which the flight crew was uninjured and were the only occupants wearing shoulder harnesses. Can occupants of these aircraft be fitted with shoulder harnesses or must this be restricted to the flight crew?

III. Rate priority of research on this issue as it relates to aviation safety.

\_\_\_\_\_ / \_\_\_\_\_ /   X   / \_\_\_\_\_ / \_\_\_\_\_  
Extremely High Moderate Low Extremely low  
High

IV. Supplementary information.

A. Evidence for importance of issues:  
Compression fractures of the spine are one such problem resulting from lack of shoulder harnesses on all occupants when a sudden deceleration occurs.

B. Future research projects needed regarding this issue:  
This will require a joint project with structural engineers to determine if it is feasible to install such shoulder harnesses.

C. Application of Findings - Safety, efficiency, and/or cost benefits expected from future research on this issue:  
Reduced injuries should result.

D. References:  
Kirkham, Wick, Snyder, personnel communication

E. (Optional) Participant name: \_\_\_\_\_

Please return by Aug 9, 1981

TO: Dr. Henry W. Mertens  
FAA/CAMI, AAC-118  
P.O. Box 25082  
Oklahoma City, OK. 73125

IDENTIFICATION OF HUMAN FACTORS ISSUES IN AVIATION: BIOMEDICAL AND BEHAVIORAL FACTORS:

I. Title of Issue or question:  
The Vertical Component of Crash Injury Impact

II. Summary of Issue or question:  
This is related to seat structure but includes aircraft structure and seat mountings. Many general aviation accidents and some air carrier accidents as well involve high vertical descent rates at impact. The result is compression fractures of the spine. Suitable crushable and slow deforming structures under the seats could prevent these injuries which often otherwise result in transections of the spinal cord.

III. Rate priority of research on this issue as it relates to aviation safety.

/	X	/	/	/
Extremely High	High	Moderate	Low	Extremely low

IV. Supplementary information.

A. Evidence for importance of issues:

A substantial number of the fatalities in GA have ruptured organs and structures as well as compression fractures and basilar skull fractures.

B. Future research projects needed regarding this issue:

Continued work on crushable structures which slow the "G" loading on the spine and to the various viscus structures prone to deceleration injuries.

C. Application of Findings - Safety, efficiency, and/or cost benefits expected from future research on this issue:

Decreased mortality and morbidity.

D. References:

Autopsy reports following accidents.

E. (Optional) Participant name: \_\_\_\_\_

Please return by Aug 9, 1981

TO: Dr. Henry W. Mertens  
FAA/CAMI, AAC-118  
P.O. Box 25082  
Oklahoma City, OK. 73125

IDENTIFICATION OF HUMAN FACTORS ISSUES IN AVIATION: BIOMEDICAL AND BEHAVIORAL FACTORS:

I. Title of Issue or question:  
Has seat design been optimized for crash injury protection?

II. Summary of Issue or question:  
A significant number of injuries are caused in otherwise survivable accidents when the seats fail, collapse, tear loose, or otherwise inflict injuries upon the occupants. Seat design improvement is still needed to prevent these types of injuries. This is applicable to both air carrier and general aviation aircraft. The design of GA seats has in some cases not improved in more than 40 years.

III. Rate priority of research on this issue as it relates to aviation safety.

\_\_\_\_\_ / X / \_\_\_\_\_ / \_\_\_\_\_ / \_\_\_\_\_  
Extremely High      Moderate      Low      Extremely low  
High

IV. Supplementary information.

A. Evidence for importance of issues:

In GA aircraft, the stall spin accident is still one of the more prevalent accident types. Impact involves both lateral and vertical decelerations. In many cases, the aircraft is relatively undamaged but the occupants die because the seat structure does not contain them within the aircraft nor spread the impact over time in a satisfactory manner.

B. Future research projects needed regarding this issue:

- 1. Survey seat construction currently in use.
- 2. Correlate injury with seat construction.
- 3. Develop prospective study for redesign and replacement of unsatisfactory seat.

C. Application of Findings - Safety, efficiency, and/or cost benefits expected from future research on this issue:

Decrease in mortality and morbidity with lessened trauma.

D. References:

Snyder many publications.

E. (Optional) Participant name: \_\_\_\_\_

Please return by Aug 9, 1981

TO: Dr. Henry W. Mertens  
FAA/CAMI, AAC-118  
P.O. Box 25082  
Oklahoma City, OK. 73125

IDENTIFICATION OF HUMAN FACTORS ISSUES IN AVIATION: BIOMEDICAL AND BEHAVIORAL FACTORS:

I. Title of Issue or question:  
Pregnant Passengers and the Use of Seat Belts.

II. Summary of Issue or question:  
Do seat belts cause injuries in the case of pregnant passengers either to the mother or the fetus? This question is commonly asked but there is little or no definitive information available to speak to it. This should be the subject of a retrospective study which can include aircraft and surface transportation accidents when searching for the answer.

III. Rate priority of research on this issue as it relates to aviation safety.

	/	/	X / X	/	
Extremely High	High	Moderate	Low	Extremely low	

IV. Supplementary information.

A. Evidence for importance of issues:

The U.S. air carrier industry transports about 300,000,000 passengers each year. They are largely unscreened from a medical standpoint and included in this group are significant numbers of mothers-to-be.

B. Future research projects needed regarding this issue:

This can be a reasonably low budget study involving followups after accidents and rapid decelerations. It does not need to make use of any prospective techniques which would ethically be unsuitable.

C. Application of Findings - Safety, efficiency, and/or cost benefits expected from future research on this issue:

Should injuries be found or other untoward medical events, a redesign of seat belts may be needed or education about the placement may be sufficient. Special padding may also be a solution for pregnant females.

D. References:

E. (Optional) Participant name: \_\_\_\_\_

Please return by Aug 9, 1981

TO: Dr. Henry W. Mertens  
FAA/CAMI, AAC-118  
P.O. Box 25082  
Oklahoma City, OK. 73125

IDENTIFICATION OF HUMAN FACTORS ISSUES IN AVIATION: BIOMEDICAL AND BEHAVIORAL FACTORS:

I. Title of Issue or question:  
Post Crash Investigation of Instrument Reading Errors

II. Summary of Issue or question:  
There are still at least four different types of altimeters in common use although at least three have been shown to be incriminated in a significant number of unwarranted descents to ground contact. A definitive study is needed to resolve the problem of altimetry and altimeter presentations.

III. Rate priority of research on this issue as it relates to aviation safety.

\_\_\_\_\_ / X / \_\_\_\_\_ / \_\_\_\_\_ / \_\_\_\_\_  
Extremely High Moderate Low Extremely low  
High

IV. Supplementary information.

A. Evidence for importance of issues:  
Unwarranted descent through errors in altimeter reading are common, serious, and result in accidents. Several other incidents have occurred which did not result in accidents only by mere chance.

B. Future research projects needed regarding this issue:  
Resolve single pointer, drum, three pointer controversy.

C. Application of Findings - Safety, efficiency, and/or cost benefits expected from future research on this issue:  
Elimination of instrument reading errors, particularly errors in reading the altimeter which should minimize ground strikes due to inadvertent descents.

D. References:  
NTSB Accident and Incident Reports.

E. (Optional) Participant name: \_\_\_\_\_

Please return by Aug 9, 1981

TO: Dr. Henry W. Mertens  
FAA/CAMI, AAC-118  
P.O. Box 25082  
Oklahoma City, OK. 73125



IDENTIFICATION OF HUMAN FACTORS ISSUES IN AVIATION: BIOMEDICAL AND BEHAVIORAL FACTORS:

I. Title of Issue or question:  
Is It Necessary to Investigate All Aircraft Accidents?

II. Summary of Issue or question:  
The difference between an accident, fatal or not, and an incident is often small and at times almost a matter of chance. At the present time, accident investigation is more random than organized. A very thoroughly investigated significant sample of accidents should provide more useful information than the current random and haphazard investigations.

III. Rate priority of research on this issue as it relates to aviation safety.

Extremely High / Moderate X / Low / Extremely low  
High

IV. Supplementary information.

A. Evidence for importance of issues:  
No definitive information is available about the number of accidents which result from physical incapacitation of the pilot. This is needed but can be obtained by a good autopsy series. A similar series is needed to obtain data on the number of suicides in aircraft. This too can probably be obtained by good psychological accident investigation.

B. Future research projects needed regarding this issue:  
Organization of investigation teams to obtain data.

C. Application of Findings - Safety, efficiency, and/or cost benefits expected from future research on this issue:

Revision of aeromedical standards as appropriate should the current examination techniques and standards need be altered.

D. References:

NTSB, FAA reports by Yanowitch.

E. (Optional) Participant name: \_\_\_\_\_

Please return by Aug 9, 1981

TO: Dr. Henry W. Mertens  
FAA/CAMI, AAC-118  
P.O. Box 25082  
Oklahoma City, OK. 73125

IDENTIFICATION OF HUMAN FACTORS ISSUES IN AVIATION: BIOMEDICAL AND BEHAVIORAL FACTORS:

- I. Title of Issue or question:  
Post Crash Investigation of Use of Upper Torso Restraints.
- II. Summary of Issue or question:  
There is little information available concerning the actual findings in the case of shoulder harness use in aircraft accidents. Some misinformation clouds the issue. Studies should be instituted in air carrier and commuter aircraft in which crew injuries are looked at vis a vis passenger injuries who were not wearing upper torso restraints. To some extent automobile accident data might also be useful.
- III. Rate priority of research on this issue as it relates to aviation safety.

/                    /                    X                    /                    /

---

Extremely High                    Moderate                    Low                    Extremely low

High

- IV. Supplementary information.
  - A. Evidence for importance of issues:  
It has been the personal experience of a number on this committee that accidents have occurred which should not have resulted in any injury but instead fatal head injuries or wedge fractures of the spinal cord have occurred. The statistical evidence of the beneficial effect of an upper torso restraint is not readily apparent. It should be.
  - B. Future research projects needed regarding this issue:  
With these data, an intense educational effort can be instituted which will encourage the use of those shoulder harnesses which are now available.
  - C. Application of Findings - Safety, efficiency, and/or cost benefits expected from future research on this issue:  
Decreased morbidity and mortality from head injuries and from flexion.
  - D. References:  
Synder R.G. various
  - E. (Optional) Participant name: \_\_\_\_\_

Please return by Aug 9, 1981

TO: Dr. Henry W. Mertens  
FAA/CAMI, AAC-118  
P.O. Box 25082  
Oklahoma City, OK. 73125

# Local 553 - Air Transport Division

5705 N.W. 38th Street  
Miami Springs, Florida 33166  
Telephone (305) 871-3692

Transport Workers Union  
of America  
AFL-CIO

Patricia Fink  
President



Dorothy A. Payne  
Financial Secretary-Treasurer

Jeanne Notaro  
First Vice President

Wm. J. Redford  
International Vice President  
Transport Workers Union

August 12, 1981

Dr. Henry W. Mertens  
FAA/CAMI, AAC-118  
P. O. Box 25082  
Oklahoma City, OK 73125

Dear Dr. Mertens:

Enclosed are suggestions for areas that I feel that CAMI can do some very constructive and timely research in the areas of cabin safety. Most of these topics were touched in the Cabin Safety group during the 5th Human Factors Workshop held at CAMI recently, which I attended.

Our union represents over 6500 Easter Air Lines Flight Attendants and feel that these areas are a concern to all the airline industry and have far reaching impacts, both economical and safety, to airlines, passengers, and crewmembers.

I also want you to know that I was extremely pleased about the recent Human Factors Workshop on Cabin Safety, and I hope FAA deems it appropriate to maintain workshops such as these in the future. I was very enlightened during the three day workshop by the various participants in all the workshops.

Please note, also, our change of mailing address, which is as follows:

TWU Local 553, Air Transport Division  
7370 N. W. 36 Street Suite 412  
Miami, FL 33166  
(305) 592-9390

Thank you for your time and consideration.

Yours truly,

Larry Robinson  
Safety Chairman  
TWU Local 553  
Air Transport Division

LR:cr  
OPEIU #128  
AFL-CIO

IDENTIFICATION OF HUMAN FACTORS ISSUES IN AVIATION: BIOMEDICAL AND BEHAVIORAL FACTORS:

I. Title of Issue or question: BIOMEDICAL AND BEHAVIORAL EFFECTS OF REDUCED AIR EXCHANGE RATES IN TRANSPORT AIRCRAFT ON SUBJECTS REPRESENTATIVE OF FLIGHT ATTENDANTS.

II. Summary of Issue or question: Reduced Air Exchange Rates per person presently occur on transport aircraft due to increased passenger capacities and reduced pressurization pack operations in order to increase revenues and reduce fuel consumption. The subsequent reduction of per person air exchange rates could potentially affect the non-sedentary flight attendant in an adverse manner.

III. Rate priority of research on this issue as it relates to aviation safety.

XXXXXXX	/		/		/		/	
Extremely High		Moderate		Low		Extremely low		
High								

IV. Supplementary information.

A. Evidence for importance of issues: Same as above in II.

B. Future research projects needed regarding this issue: Pressure chamber tests with subjects representative of flight attendant crewmembers.

C. Application of Findings - Safety, efficiency, and/or cost benefits expected from future research on this issue: Findings could affect significantly aircraft design and operations of pressurization systems.

D. References: None

E. (Optional) Participant name: Larry Robinson - Safety chairman  
TWU Local 553, Air Transport Div.  
7370 N.W. 36th St., Miami, FLA 33166  
Please return by Aug 9, 1981

TO: Dr. Henry W. Mertens  
FAA/CAMI, AAC-118  
P.O. Box 25082  
Oklahoma City, OK. 73125

IDENTIFICATION OF HUMAN FACTORS ISSUES IN AVIATION: BIOMEDICAL AND BEHAVIORAL FACTORS:

I. Title of Issue or question: Applicability of Shoulder/Lap Restraint Systems for Air Transport Aircraft Passengers.

II. Summary of Issue or question: Due to changes in passenger seat design, mainly in pitch and incline, the potential for impact injuries to passengers on transport category aircraft is increased. Relevant and timely research in this area is greatly needed.

III. Rate priority of research on this issue as it relates to aviation safety.

XXXXXXXXX /	/	/	/	/
Extremely High	Moderate	Low	Extremely low	
High				

IV. Supplementary information.

A. Evidence for importance of issues: Past CAMI research in seat designs identifies that impact injury potential increases as reduced pitch and incline of passenger seats occur. The crashworthiness of the seat/restraint system/passenger unit in the new pitch/incline configurations need relevant and timely research in order to maintain a reasonable level of safety for the traveling public.

B. Future research projects needed regarding this issue: Dynamic sled testing at 6, 9, and 12G levels is deemed appropriate.

C. Application of Findings - Safety, efficiency, and/or cost benefits expected from future research on this issue: FAA rulemaking and TSO standards can be derived from information, data, and insight revealed by this research.

D. References: None

E. (Optional) Participant name: Larry Robinson - Safety chairman  
TWU Local 553, Air Transport Div.  
7370 N.W. 36th St. Miami, FLA 33166  
Please return by Aug 9, 1981

TO: Dr. Henry W. Mertens  
FAA/CAMI, AAC-118  
P.O. Box 25082  
Oklahoma City, OK. 73125

LIST OF ATTENDEES

LIST OF ATTENDEES

Fifth Human Factors Workshop  
on Aviation

Mr. Anthony Adamski  
Chrysler Corp.  
Box 824  
Willow Run Airport  
Ypsilanti, MI 48197

Mr. Dominck A. Alfieri  
Assistant Vice President, Claims  
U.S. Aviation Underwriters  
110 William Street  
New York, NY 10038

Mr. Robert Alkov  
Aviation Psychologist, Aeromedical Div.  
Naval Safety Center  
Naval Air Station  
Norfolk, VA 23511

Mr. David Anderson  
FAA  
800 Independence Ave., S.W.  
Washington, DC 20591

Mr. Karl F. Anderson  
Executive Vice President  
Flt Engineers' Int. Ass. AFL-CIO  
905 16th Street, N.W.  
Washington, DC 20006

Kay Avery  
Administrator, Flight Service  
American Airlines, Inc.  
AAL Plaza, Learning Center  
Ft. Worth, TX 76035

Sharon A. Barthelmess  
Cabin Safety Specialist  
FAA, ASF-300  
800 Independence Ave., S.W.  
Washington, DC 20591

Mr. James V. Bernadini  
Civil Aeromedical Institute, AAC-142  
P.O. Box 25082  
Oklahoma City, OK 73125

C.M. Bertone  
Chief, Human Factors Engineer  
SiKorsky Aircraft  
North Main Street  
Stratford, CT 06602

Mr. James O. Boone  
Chief, Selection/Testing Research  
Civil Aeromedical Institute  
P.O. Box 25082  
Oklahoma City, OK 73125

Mr. Charles Booze  
Aeromedical Certification Branch  
Medical Statistical Section, AAC-132  
P.O. Box 25082  
Oklahoma City, OK 73125

Mr. Henri Branting  
Aerospace Engineer  
FAA Aircraft Engineering Div.  
800 Independence Ave., S.W.  
Washington, DC 20591

Jackie Brederlow  
Air Carrier Inspection (Large Airplanes)  
Transport Canada, Tower C  
Place de Ville  
Ottawa, Ontario K1A0N8

Zita Brunet  
Air Carrier Inspection (Large Airplanes)  
Transport Canada, Tower C  
Place de Ville  
Ottawa, Ontario K1A0N8

Mr. Anthony Buige  
FAA, OSEM  
800 Independence Ave., S.W.  
Washington, DC 20591

Mr. Caesar Caiafa  
FAA Technical Center  
Atlantic City Airport, NJ 08405

Mr. James Carroll  
Claim Supervisor  
U.S. Aviation Underwriters  
110 William Street  
New York, NY 10038



J.E. Carroll  
Captain  
Vice President  
Flight Standards and Training  
United Airlines  
Stapelton International Airport  
Box 66100  
Denver, CO 80207

Mr. Edward L. Cates  
SGT USAF Hospital  
Little Rock AFB, AR

Mr. Richard F. Chandler  
Chief, Protection/Survival Lab  
Civil Aeromedical Institute  
P.O. Box 25082  
Oklahoma City, OK 73125

Mr. Ron Ciolli  
11771 Natural Bridge  
Bridgeton, MO 63044

Mr. Richard Clarke  
Director of Operations  
Flight Safety Foundation, Inc.  
5510 Columbia Pike  
Arlington, VA 22204

Mr. Jerald D. Cockrell  
Consulting Psychologist  
A.O.P.A. Air Safety Foundation  
Rt. 2, Box 266  
Wartrace, TN 37183

Mr. William E. Collins  
Chief, Aviation Psychology Lab  
Civil Aeromedical Institute, AAC-118  
P.O. Box 25082  
Oklahoma City, OK 73125

C.W. Conner  
Delta Airlines  
ERAU Graduate School  
9420 S.W. 102 Ct  
Miami, FL 33176

Adriaan A.G. Cooper  
Manager, Structures  
Fairchile Burns  
1455 Fairchild Drive  
Winston-Salem, NC 27105

Mr. Michael Costello  
Southwest Airlines  
P.O. Box 37611  
Love Field  
Dallas, TX 75235

Cynthia Cox  
Civil Aeromedical Institute, AAC-119  
P.O. Box 25082  
Oklahoma City, OK 73125

Mr. Jack G. Daubs  
Epidemiologist  
TWR Corp.  
173 Central Ave.  
Milton, MA 02186

Mr. Don De Steiguer  
Chief, Survival Research Unit  
Civil Aeromedical Institute  
P.O. Box 25082  
Oklahoma City, OK 73125

Mr. Fred G. DeLacerda  
Human Performance Lab.  
Oklahoma State Univ.  
Colvin Center  
Still Water, OK 74078

Mr. Allen Diehl  
Program Scientist  
FAA Aviation Medicine AAM-540  
800 Independence Ave., S.W.  
Washington, DC 20591

Mr. J. Robert Dille  
Chief, Civil Aeromedical Institute, AAC-100  
P.O. Box 25082  
Oklahoma City, OK 73125

Robin Dodge  
Wright State University  
P.O. Box 927  
Dayton, OH 45401

Marie Doll  
Air Carrier Inspection (Large Airplanes)  
Transport Canada, Tower C  
Place de Ville  
Ottawa, Ontario K1A0N8

Mr. Duane Edelman  
Flight Standards  
Republic Airlines  
7500 Airliner Drive  
Minneapolis, MN 55423

Mr. Bill Edmunds  
Human Performance Specialist  
Airline Pilots Assoc.  
1625 Massachusetts Ave., N.W.  
Washington, DC 20036

R.L. Edwards  
Suite 900, Brickell Centre  
799 Brickell Plaza  
Miami, FL 33131

Mr. Charles S. Erwin  
Chief, Aerospace Physiology  
U.S. Air Force  
USAF Clinic/SGT  
Vance, AFB, OK 73701

Mr. Walter Fenstermacher  
Flight Standards Branch  
Aircraft Maintenance Unit, AAC-952A  
P.O. Box 25082  
Oklahoma City, OK 73125

H. Clayton Fouschee  
Research Psychologist  
NASA, MS 239-3  
NASA, Ames Research Center  
Moffett Field, CA 94035

J.D. Garner  
Chief, Emergency Evacuation  
CAMI-Retired  
7412 N.W. 21st  
Bethany, OK 73008

S.R. Gerber  
Coroner  
Cuyahoga County Coroner's Office  
2121 Adelbert Road  
Cleveland, OH 44106

Mr. Charles Graham  
Principal Psychologist  
Midwest Research Institute  
425 Volker Blvd.  
Kansas City, MD 64110

Mr. George Harris  
Pres. Harris Corp.  
1222 S. Carson  
Tulsa, OK 74119

Mr. George C. Hay  
Chief, Special Programs Div.  
FAA Office of Aviation Safety  
800 Independence Ave., S.W.  
Washington, DC 20591

Lloyd Hitchcock  
Engineering Research Psychologist  
FAA Technical Center  
ACT-200  
Atlantic City Airport, NJ 08405

Mr. Frank Holloway  
University of Oklahoma Health Sciences Center  
P.O. Box 26901  
Oklahoma City, OK

Mr. Andrew Horne  
Medical Officer  
FAA  
800 Independence Ave., S.W.  
Washington, DC 20591

Mr. John S. Howitt  
Medical Dept., CAA House  
45-59 Kingsway  
London, WC2B  
ENGLAND

Mr. Stephen Huntley  
Engineering Psychologist  
DOT/Transportation Systems Center  
Kendall Square  
Cambridge, MA 02142

Mr. Fred C. Hyman  
Candidate Biological Psychology/Pilot  
O.U. Health Sciences Center  
924½ N.W. 17th  
Oklahoma City, OK 73106

Maggie Jennings  
CSC/ATC Simulation Facility  
FAA Technology Center  
Atlantic City, NJ 08405

Mr. Walter Jensen  
Air Transport Association of America  
1709 New York Ave., N.W.  
Washington, DC 20006

Mr. Don Johnson  
President  
Interaction Research Corp.  
2002 E. State  
Olympia, WA 98506

Karen N. Jones  
Personnel Research Psychologist  
U.S. Coast Guard Institute  
P.O. Substation 18  
Oklahoma City, OK 73169

Mr. John C. Kal  
ATTN: AAS 300  
Office of Airport Standards, FAA  
800 Independence Avenue, SW.  
Washington, D.C. 20591

Toni Ketchell  
Assoc. of Professional Flight Attendants  
1004 W. Euless Blvd.  
Euless, TX 76039

Mr. William R. Kirkham  
Chief, Aviation Toxicology Lab  
Civil Aeromedical Institute  
P.O. Box 25082  
Oklahoma City, OK 73125

Jeanne Koreltz  
Flight Attendant Training Instructor  
Republic Airlines, Inc.  
7500 Airline Drive  
Minneapolis, MN 55450

Mr. Michael T. Lategola  
Chief, Cardiorespiratory Unit  
Civil Aeromedical Institute  
P.O. Box 25082  
Oklahoma City, OK 73125

Mr. Russell S. Lawton  
Operations and Safety  
Aircraft Owners & Pilots Association  
7315 Wisconsin Ave.  
Washington, DC 20014

Mr. Jerome Lederer  
Institute of Nuclear Power Operations  
468-D Calle Cadiz  
Laguna Hills, CA 92653

Mr. Dwight Lindsey  
Research Psychologist  
U.S. Army Safety Center  
Ft. Rucker  
Alabama 36363

Mr. Michael W.B. Lock  
Cranfield Institute  
Bedford, England

Mr. George Long  
Senior Scientist  
FAA Technical Center  
Atlantic City Airport, NJ 08405

Mr. Donald Lee Lowrey  
FAA Aeronautical Center  
Civil Aeromedical Institute, AAC-114  
P.O. Box 25082  
Oklahoma City, OK 73125

Mr. Walter Luffsey  
FAA Associate Adm. for Av Standards  
800 Independence Ave., S.W.  
Washington, DC 20591

D.K. (Benny) Lynch  
Supervisor, Passenger Safety  
Air Carrier Inspection (Large Airplanes)  
Transport Canada, Tower C,  
Place de Ville  
Ottawa, Ontario K1A0N8

W. MacIntyre  
Air Carrier Inspection (Large Airplanes)  
Transport Canada, Tower C  
Place de Ville  
Ottawa, Ontario K1A0N8

Mr. Carlton E. Melton  
Chief, Aviation Physiology Lab., AAC-115  
Civil Aeromedical Institute  
P.O. Box 25082  
Oklahoma City, OK 73125

Mr. Henry W. Mertens  
Chief, Human Performance Unit, AAC-118  
Civil Aeromedical Institute  
P.O. Box 25082  
Oklahoma City, OK 73125

Mr. Curtis A. Mertz  
Pres. Mertz & Stockman, Inc.  
Box 370  
4605 Elm Avenue  
Ashtabwa, OH 44004

Jan Million  
The Ninety-Nines, Inc.  
P.O. Box 59965  
Oklahoma City, OK 73159

Mr. Stanley R. Mohler  
Wright State Univ. School of Med.  
P.O. Box 927  
Dayton, OH 45401

Mr. George C. Mohr  
Commander  
AF Aerospace Medical Research Lab.  
Wright-Patterson AFB  
Dayton, OH 45433

Mr. Ted Moody  
Cessna Aircraft Co. Pawnee D  
5800 E. Pawnee  
Wichita, KS

D.E. Murphy  
Chief, Design Engineering, 36-46  
Douglas Aircraft Company  
3855 Lakewood Blvd.  
Long Beach, CA 90846

Mr. Roger P. Neeland  
Chief  
Airborne Systems Branch  
800 Independence Ave., S.W.  
Washington, D.C. 20591

Mr. Hal Nord  
President  
Aviation Management Advisors, Inc.  
41 South Road  
Rye Beach, NH 03871

Mr. Harry W. Orlady  
Captain  
Orlady Associates, Inc.  
312 So. Park Road  
LaGrange, IL 60525

Mr. James F. Parker, Jr.  
Biotechnology, Inc.  
3027 Rosemary Lane  
Falls Church, VA 22042

Leslie M. Pattersen  
Technical Staff  
The MITRE Corp.  
Bedford, MA 01730

Mr. Bill Picatti  
Bell Industry  
Far West Manufacturing Div.  
18225 N.W. 76th Street  
Redmond, WA 90052

Evan Pickrel  
Program Scientist  
FAA Aviation Medicine AAM-500  
800 Independence Ave., S.W.  
Washington, DC 20591

Mr. Hank Putek  
Manager of Training  
Piper Aircraft Corp.  
Lockhaven, PA 17745

Mr. John P. Reese  
Director, Airworthiness Programs  
Aerospace Industries Association  
1725 DeSales St., NW.  
Washington, D.C. 20036

Mr. Roy E. Reichenbach  
Chief, Aircraft Safety Division  
FAA Technical Center  
Atlantic City Airport, NJ 08405

Mr. Alvin M. Revzin  
Chief, Neuropharmacology Unit  
Civil Aeromedical Institute  
P.O. Box 25082  
Oklahoma City, OK 73125



Susan E. Richardson  
USAF Hospital  
Little Rock/Physiological Training  
2802 Grayfox Lane  
Jacksonville, AR 72075

Mr. Larry Robinson  
Eastern Airlines  
Transport Worker's Union - LCL 553  
9310 Fontainebleau Boulevard #113  
Miami, FL 33172

P.R. Robinson  
Captain  
Airline Pilots Association  
666 Cheatham Drive  
Marietta, GA 30064

Mr. Phil Rogers  
Design Engineer  
Luminator Div. of Gulton Ind.  
1200 E. Plano Parkway  
Plano, TX 75074

Mr. Stanley N. Roscoe  
Professor of Psychology  
New Mexico State Univ.  
Box 5095  
Las Cruces, NM 88003

Mr. Robert Rose  
Chairman, Dept. of Psychiatry  
Univ. of Texas Medical Branch  
Room 1,200, Graves Bldg.  
Galveston, TX 77550

Mr. William B. Rourke  
Metropolitan State College  
Sigma Systems  
1006 Eleventh Street  
Denver, CO 80439

Kathy Russo  
Assoc. of Professional Flight Attendants  
1004 W. Eules Blvd.  
Eules, TX 76039

Mr. David J. Schroeder  
Chief, Clinical Psy. Unit, AAC-118  
Civil Aeromedical Institute  
P.O. Box 25082  
Oklahoma City, OK 73125

S.B. Sells  
Research Professor and Director  
Institute of Behavioral Research  
Texas Christian University  
Fort Worth, TX 76129

Mr. Steve Sheek  
Fairchild Burns Company  
1455 Fairchild Drive  
Winston-Salem, NC 27105

Mr. William T. Shepherd  
Program Scientist  
FAA Aviation Medicine AAU-550  
800 Independence Ave., S.W.  
Washington, DC 20591

W.H. Shook  
Design Coordinator - Safety  
Douglas Aircraft Co.  
3855 Lakewood Blvd.  
Long Beach, CA 90846

Mr. Jim Simpson  
Transportation Injury Specialist, Inc.  
301 Ranblin Oaks  
Moore, OK 73160

Mr. Paul W. Smith  
Consultant  
1324 N.E. 56th  
Oklahoma City, OK 73111

Trudy Smith  
Assoc. of Professional Flight Attendants  
1004 W. Eulesse Blvd.  
Eulesse, TX 76039

Mr. Richard G. Snyder  
Biomedical Dept.  
Highway Safety Research Institute  
University of Michigan  
Ann Arbor, MI 28109

Mr. Richard Sulzer  
Aviation Consultant  
204 Hemlock Drive  
Linwood, NJ 08221