

1. Report No. DOT-TSC-UMTA-73-1		2. Government Accession No.		3. Recipient's Catalog No. PB-220 795	
4. Title and Subtitle DEVELOPMENT AND TESTING OF A COMPLETELY PASSIVE, AIR SUSPENDED, AIR PROPELLED PERSONAL RAPID TRANSIT VEHICLE				5. Report Date April, 1973	
				6. Performing Organization Code	
7. Author(s) Charles H. Smoot et al				8. Performing Organization Report No. DOT-TSC-UMTA-73-1	
9. Performing Organization Name and Address Uniflo Systems Company 7401 Washington Avenue South Minneapolis, Minnesota 55435				10. Work Unit No. UM306/R3722	
				11. Contract or Grant No. DOT-TSC-367	
12. Sponsoring Agency Name and Address U.S. Department of Transportation Urban Mass Transportation Administration Office of Research, Development & Demonstrations Washington, D.C. 20590				13. Type of Report and Period Covered Final Report March, 1972 to August, 1972	
				14. Sponsoring Agency Code	
15. Supplementary Notes <div style="text-align: center;">Reproduced by NATIONAL TECHNICAL INFORMATION SERVICE US Department of Commerce Springfield, VA. 22151</div>					
16. Abstract <p>A prototype Uniflo vehicle base with mock-up superstructure was tested on 55 ft. of full-scale track.</p> <p>Sound treatment to meet NCA 60 at 25 ft. from the guideway enclosure and within the vehicle was proposed and the costs determined.</p> <p>A heating and cooling system using passive vehicle heat sink elements with station berth recharging was found desirable because of its lower cost and reliability.</p> <p>An evaluation of the estimated production quantity costs for the vehicle base, guideway surface, levitation and thrust elements showed a reduction of 49% compared to previous design estimates.</p> <p>Extensive tests confirmed the feasibility of the track based linear air turbine used for acceleration and service braking in the Uniflo PRT system.</p> <p>Ride quality measurements indicated a need for improved secondary suspension.</p> <p>Empty vehicle speeds over 20 ft./sec. and accelerations exceeding 5 ft./sec.² were achieved with an air flow of 72.0 ft.³/sec. Vehicle starting drag was less than 5 lbs. force.</p>					
17. Key Words PRT (Personal Rapid Transit) Air Cushion Vehicles Passive Vehicle Circulation and Distribution			18. Distribution Statement DOCUMENT IS AVAILABLE TO THE PUBLIC THROUGH THE NATIONAL TECHNICAL INFORMATION SERVICE, SPRINGFIELD, VIRGINIA 22151		
19. Security Classif. (of this report) Unclassified		20. Security Classif. (of this page) Unclassified		21. No. of Pages	22. Price

PREFACE

This report covers work accomplished under Contract No. DOT-TSC-367 from the U.S. Department of Transportation, Transportation Systems Center, 55 Broadway, Cambridge, Massachusetts.

Each portion of the body of this report has its own author who conducted the development and test work described.

The authors are as follows:

Guideway Operating Surface – Lowell A. Kleven
Full-scale Test Vehicle – Gary J. Wirth
System Noise Emissions – Lowell A. Kleven
Heating, Ventilating and Air Conditioning Study – Lloyd E. Berggren
Component Cost Estimates – Frank J. Palcher
System Performance Information – Lowell A. Kleven and Gary J. Wirth

All of the hardware constructed and tested during this project was based on designs previously developed by the Uniflo Systems Company, a subsidiary of Rosemount Inc. 12001 West 78th Street, Minneapolis, Minnesota 55435. Many refinements to these basic designs were added during the project, and the necessary short-run tooling was developed and built as part of the project.

As a subcontractor, the International Acoustical Testing Laboratories, Inc. made valuable contributions to this project. In addition to the sound measurements and analysis, their recommendations are embodied in the vehicle superstructure and guideway treatment.

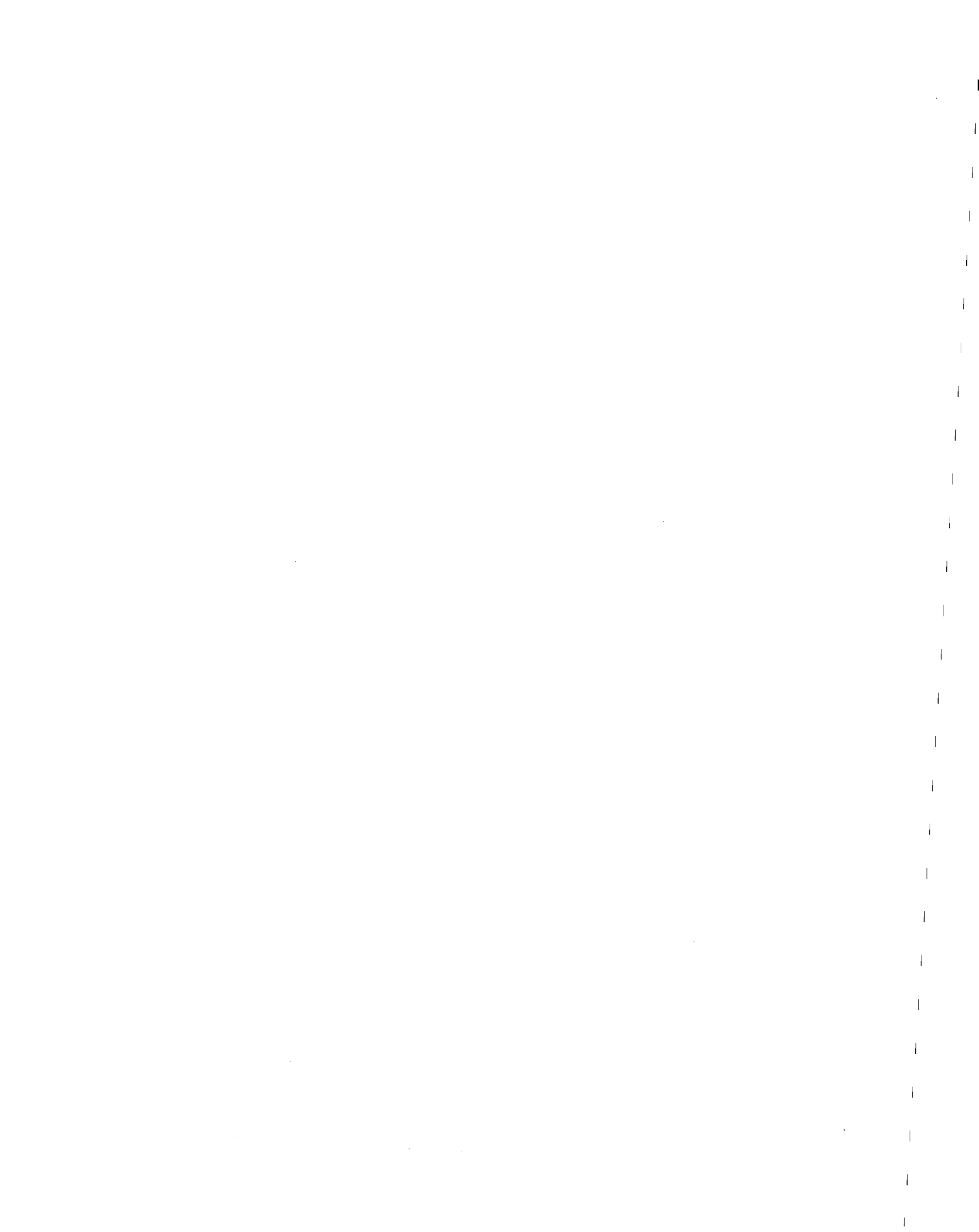
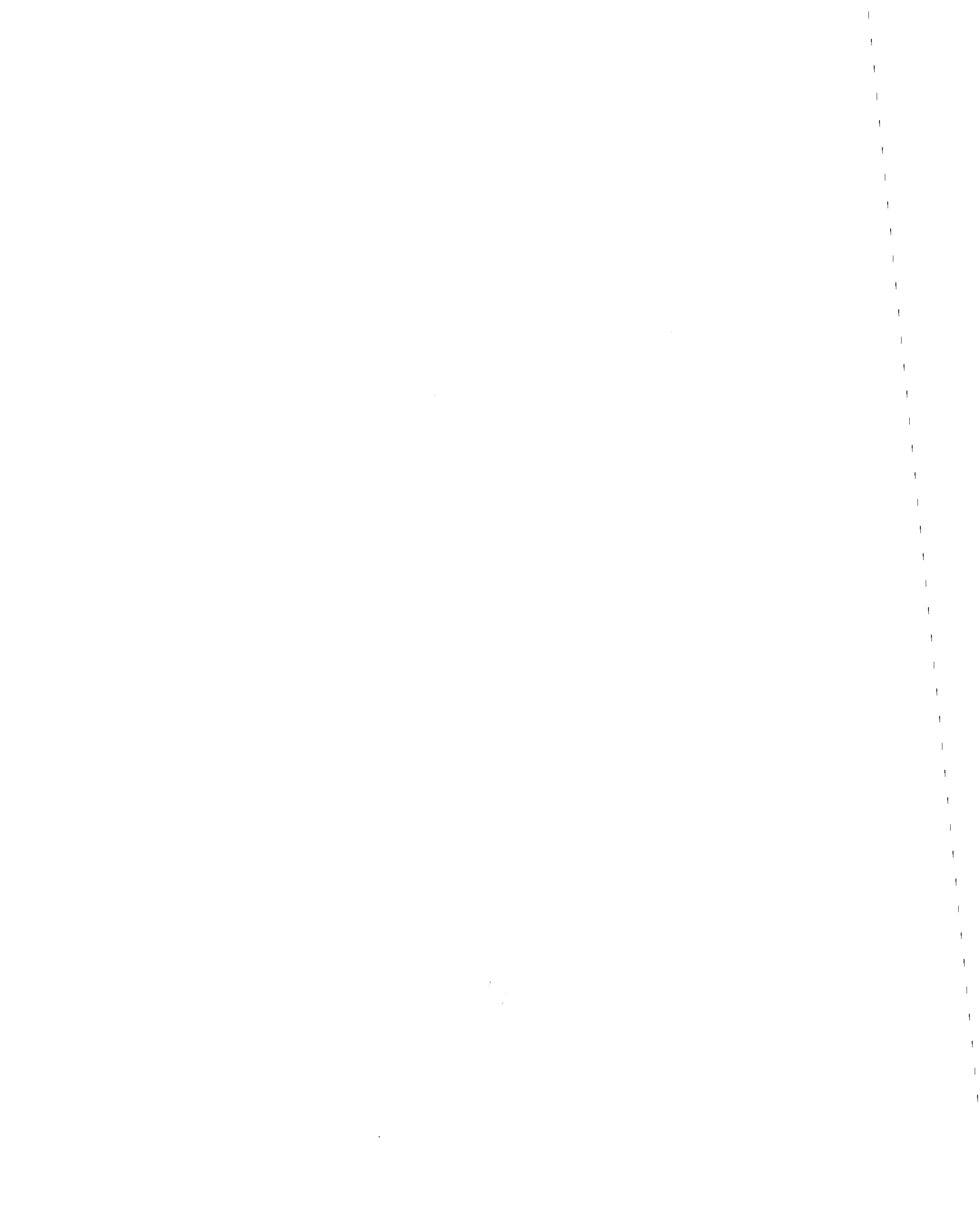

TABLE OF CONTENTS

Preface	I
List of Drawings	V
List of Figures	VII
List of Tables	IX
1.0 Guideway Operating Surface	
1.1 Background	1
1.2 Operating Surface Design and Installation	1
1.3 Turbine Module Design and Construction	9
1.4 Control System	9
1.5 Air Supply	12
2.0 Full-Scale Test Vehicle	
2.1 Background	15
2.2 Vehicle Description	15
3.0 System Noise Emissions	
3.1 Background	29
3.2 Testing Methods	29
3.3 Data Reduction and Discussion	31
3.4 Enclosure Treatment	37
3.5 Acoustical Treatment for the Vehicle	40
3.6 Conclusions and Recommendations	42
4.0 Heating, Ventilating, and Air Conditioning Study	
4.1 Abstract	43
4.2 Background	43
4.3 Vehicle Air Conditioning by Blower Station Based Air Conditioner	46
4.4 Vehicle Air Conditioning by Vehicle Borne Heat Sink	49
4.5 Conclusions	56
5.0 Component Cost Estimates	
5.1 Background	59
5.2 System Component Costs	59
5.3 Estimated Capital Equipment Costs	65
5.4 Summary and Conclusions	67
6.0 System Performance Information	
6.1 Background	69
6.2 Test Instrumentation and Conditions	
6.2.1 Instrumentation	70
6.2.2 Test Conditions	72
6.3 Linear Turbine Performance	74
6.4 Ride Quality	77
6.5 Emergency Braking	79
6.6 Conclusions and Recommendations	80
APPENDICES	
A Report of Inventions Appendix	A-1
B Heating, Ventilating, and Air Conditioning Study Considerations	B-1
References	81

Preceding page blank



LIST OF DRAWINGS

Drawing No.		Page
E-00485	Uniflo Test Facility	2
E-00461	Guideway, Fixed	3
E-00320	Operating Surface, Section Joint	6
E-00476	Operating Surface, Section Joint, Top View	7
E-00339	Operating Surface, Expansion Joint	8
E-00465	Turbine Module Assembly	10
E-00523	System Control	11
E-00522	Uniflo Vehicle Prototype Mock-Up	18
E-00505	Vehicle Base Modifications	19
E-00227	Vehicle Base Cross Section	20
E-00528	Levitation Pad Assembly	21
E-00532	Levitation Pad Interconnecting Hardware	22
E-00534	Eight-Pad Interconnect Schematic	23
E-00509	Air Conditioning Pop-Out Valve	24
E-00530	Vehicle Dampening Installation	25
E-00497	Thrust Bucket	26
E-00501	Vehicle Thrust Bucket Assembly	27

Preceding page blank

LIST OF FIGURES

Figure No.	Title	Page
1-1	Test Facility Guideway	1
1-2	Uniflo Operating Surface	4
1-3	Blower Performance Curves	12
1-4	150 HP Blower and Motor Installation	13
2-1	Vehicle Bottom	16
2-2	Acoustical Baffling	16
2-3	Vehicle Rotated 90° for Maintenance	17
2-4	Load Boxes Entering Vehicle	17
3-1	Sound Equipment – 25 foot point	30
3-2	Sound Equipment – in vehicle	31
3-3	Background Noise with Blower Running	32
3-4	Sound Pressure Levels – 25 foot point – full vehicle	33
3-5	Sound Pressure Levels – 25 foot point – empty vehicle	33
3-6	Sound Pressure Levels (corrected) – 25 foot point – empty vehicle	34
3-7	Sound Pressure Levels (corrected) – 25 foot point – full vehicle	34
3-8	Sound Pressure Levels – inside empty vehicle	35
3-9	Sound Pressure Levels – inside full vehicle	35
3-10	Sound Pressure Levels DBA vs. Time – 25 foot point	36
3-11	Sound Pressure Levels DBA vs. Time – inside vehicle	36
3-12	Typical Structural Guideway Enclosure	37
3-13	Sound Pressure Levels (corrected) – 25 foot point – full vehicle – recommended enclosure	39
3-14	Sound Pressure Levels (corrected) – 25 foot point – empty vehicle – recommended enclosure	39
3-15	Sound Pressure Levels DBA (corrected) – 25 foot point – recommended enclosure	40
4-1	One-Way Elevated Structure	45
4-2	Blower Station Based Cooling “A”	46
4-3	Blower Station Based Cooling “B”	47
4-4	Blower Station Based Cooling “C”	48
4-5	Heat Sink Unit – Vehicle Installation Diagram	49
4-6	Heat Sink Unit – Circulation System	50
4-7	Heat Sink Unit – Regeneration System	51
4-8	Vehicle Borne Heat Sink Unit Alt. 1	52
4-9	Vehicle Borne Heat Sink Unit Alt. 2	53
4-10	Vehicle Borne Heat Sink Unit Alt. 3	54
4-11	Vehicle Borne Heat Sink Unit Alt. 4	55
5-1	Uniflo System Components	60
5-2	Turbine Assembly	62
5-3	Vehicle Components	63
5-4	Vehicle Thrust Bucket	64

Preceding page blank

LIST OF FIGURES (CONT.)

Figure No.	Title	Page
6-1	Vehicle Entering Arresting Mechanism	69
6-2	Vehicle in Arresting Mechanism – fully extended	69
6-3	Accelerometer Installation	70
6-4	Tachometer	70
6-5	Position Detector	71
6-6	Power Cable Arrangement	71
6-7	Vehicle Borne Test Equipment	71
6-8	Vehicle Weighing Set-up	72
6-9	Turbine Performance vs. Velocity	75
6-10	Turbine Efficiency vs. Velocity	76
6-11	Thrust vs. Vehicle Lateral Displacement	76
6-12	Typical Run Data Plot with Full Vehicle and Emergency Braking . .	78
6-13	Permitted Maximum Vertical and Lateral/Longitudinal Vibration Levels on Urban Trips	79
B-1	Heat Sink Unit Operating Time	B-3
B-2	Heat Sink Unit Schematic	B-5

LIST OF TABLES

Table No.	Title	Page
3-1	Sound Transmission Loss	38
3-2	Absorption Data for Interior of Treated Car	41
4-1	Summary of Analysis of Alternate System Approaches to Vehicle-Borne Heating and Cooling	57
6-1	Test Conditions	73
6-2	Ride Quality	77
6-3	Emergency Brake Data	80
B-1	Tube Heat Transfer Rates	B-4

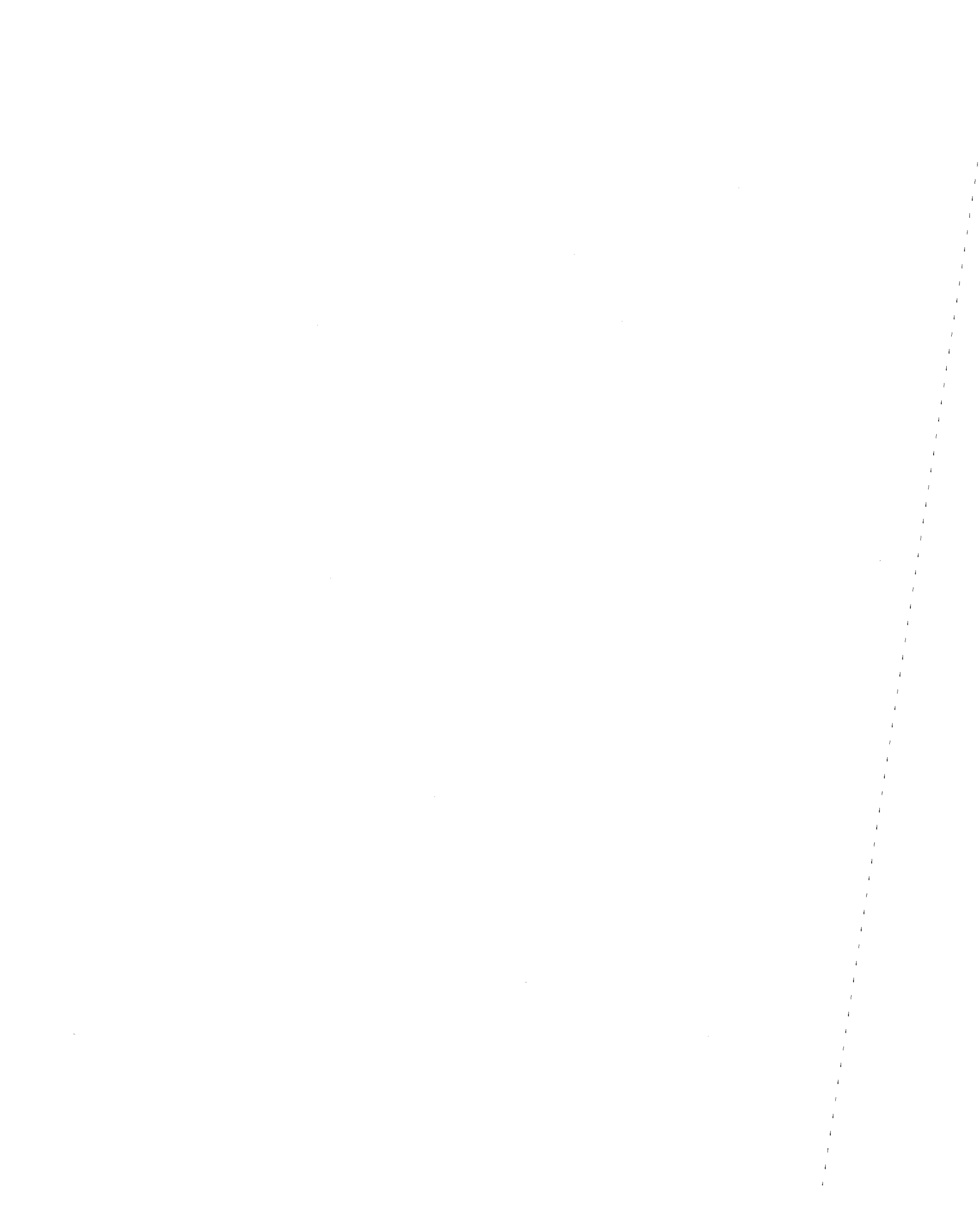

1.0 GUIDEWAY OPERATING SURFACE

1.1 BACKGROUND

This phase of the contract work was to design and install a full-scale prototype guideway, with a minimum length of 30 ft. The guideway was to contain production prototype levitation valves and acceleration and braking thrusters.

The guideway of a Uniflo system is composed of two basic elements: 1) the operating surface, and 2) the structural enclosure. Since the guideway was installed inside the Uniflo plant, no structural enclosure was necessary, and the operating surface was installed on the floor of the plant.

Eighty-seven feet of guideway surface were constructed. The installed guideway was made of two different elements. A 55 foot portion of the guideway was of a production prototype design with prototype levitation valves and turbine modules. A 32 foot portion was made from an existing plywood operating surface with only levitation valves, and no turbine modules .

Another contract requirement was the provision for an air supply capable of providing full acceleration and deceleration capability. A 150 HP blower was installed which supplied air at 2.3 to 2.6 psi and up to 150 ft.³/sec. air flow.

1.2 OPERATING SURFACE DESIGN AND INSTALLATION

The system layout is shown on Drawing E-00485, and Figure 1-1 shows photographs of the system.

The facility was laid out so that the vehicle could be tested for acceleration, dynamic braking, and emergency braking.

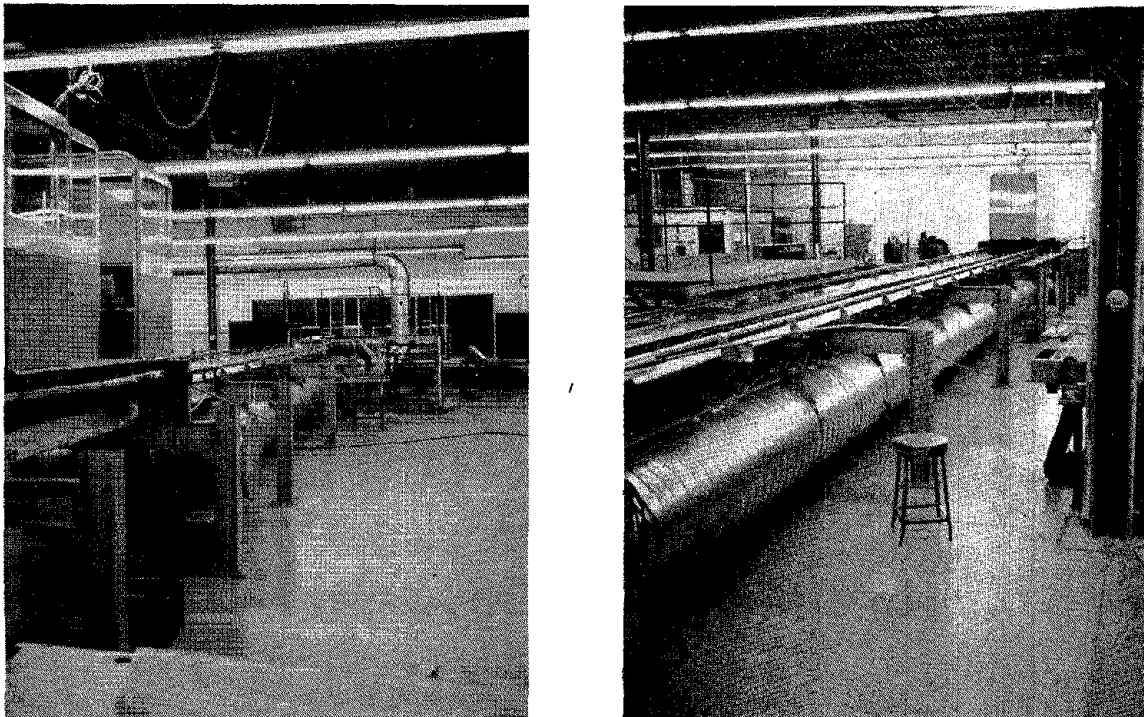
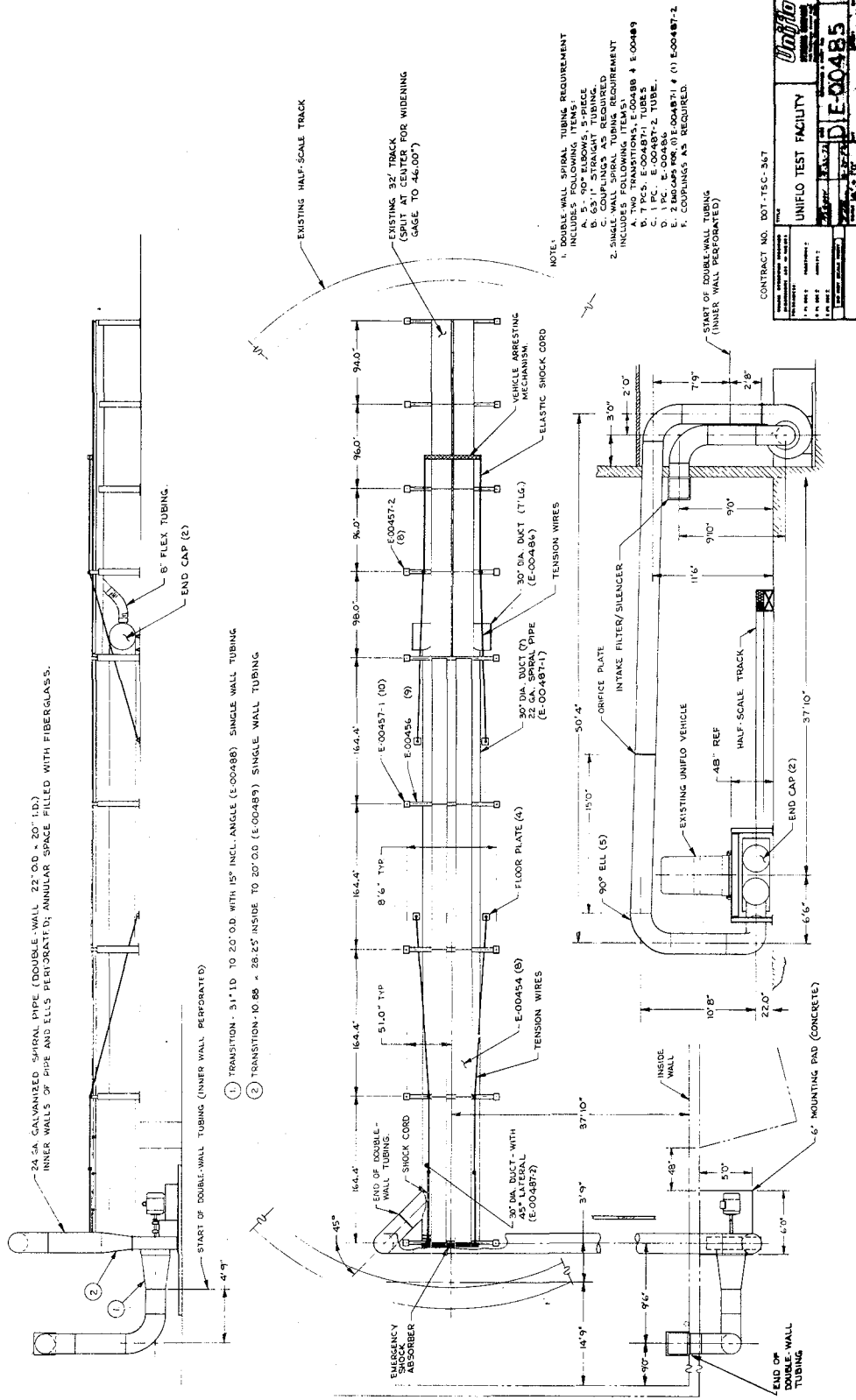
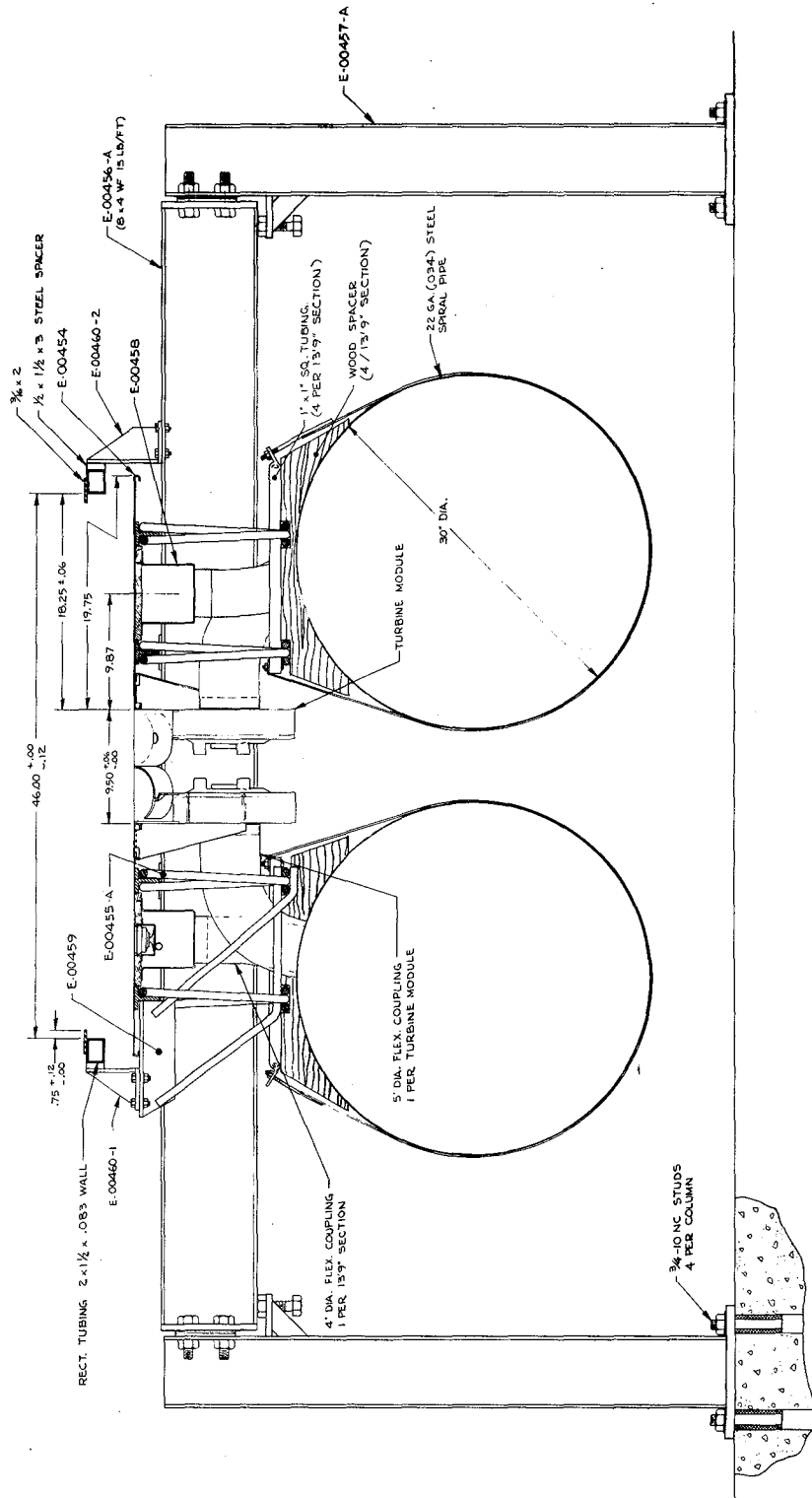

Figure 1-1. Test Facility Guideway from each end.





GUIDEWAY, FIXED	
UNION BUG	
DATE	BY
APPROVED	REVISION
NO. OF SHEETS	SHEET NO.
PROJECT NO.	DATE
E-00459	

The 55 ft. of prototype guideway had full acceleration capability in the direction toward the vehicle arresting mechanism. The minimum thrust was

This section, vehicle was

cc
ar
w
cc
sf
at
di
tc
U

th
is
(.C
jo:

one turbine module per operating surface section of 13 ft. 9 in). Only minimum thrust was to accelerate the vehicle from the far end of the 55 ft. section where the vehicle emergency braked.

The arresting mechanism consisted of one continuous 5/8" diameter elastic shock absorber cords of rubber covered with fabric. The single cord was woven back

of the vehicle about 10 ft. long were obtained. An aluminum channel which mated with the vehicle, and held the shock cords. Two additional aluminum channel and shock cords upon recoil. The cord provided a weight of 10 lbs. per foot, and enabled storage of 16,500 foot pounds of energy loss in the shock cords was between 12% and 15%, and the velocity of cord return was less than 9%. This operation allowed higher speeds away and fewer turbine modules in the space limitations of the

operating surface were made of existing designs. Drawing E-00461 shows Figure 1-2 shows a photograph of the operating surface. The operating surface with two identical halves. Each half is constructed of 13 ga. galvanized steel surface, which is supported by two special bar joists. The bar joists kept the levitation surface flat when the vehicle traverses the section.

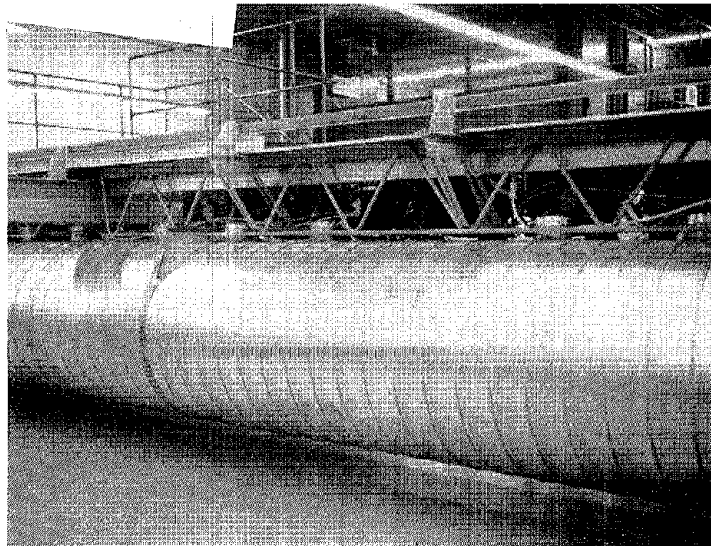

Figure 1-2. Uniflo Operating Surface

The bar joists are supported at each end with a cross beam. An adjustment between the vertical column and the cross beam provides means to level the operating surface. During installation, a surveyor's level was used to level the operating surface. The vertical columns were bolted to the concrete floor.

Centered between the bar joists and connected to the 13 ga. levitation surface is an air supply duct. This duct provides air to the levitation valves and holds the control manifolds.

The main air supply is provided by two 30 inch diameter spiral wrapped 22 ga. (.034 inches) galvanized steel tubes. These tubes weigh 12.7 lbs. per foot, and have a seam failure strength higher than 48 psi.

Connections between the levitation surface duct and the main supply duct are made with 4 inch diameter flexible tubing. The turbine modules are connected to the main air supply with 5 inch diameter

tubing of the same type, and brackets were attached to the levitation surface to hold the turbine modules.

The levitation valves were of previous design, and have been used on the 20" gauge Uniflo track for several years. These valves were mounted in the levitation surface with a wood interface. The wood interface is only a temporary design; its use avoided construction of tooling for the valve mounting ring.

The operating surface was checked for deflections due to vehicle imposed loads. These deflections have a relationship to ride quality. The deflection of the operating surface cross beam assembly at the center of the bar joist span was .041 inches with a fully loaded vehicle (3,200 lbs.). The cross beam, at the center of the operating surface half, deflected .021 inches maximum, and .015 inches when the bar joist deflection is maximum. The bar joist deflection alone calculates at .026 inches.

The construction requirements for the operating surface were specified to be flat within .06 inches.

Checkout of the operating surface showed some areas were raised more than .19 inch from flat. These areas were flattened to specification by squeezing with a hydraulic press on the lower tension member of the bar joist until it became longer. This method suggests a simple way to flatten or to camber the operating surfaces as requirements dictate.

Deflections of the edge of the operating surface where the turbine modules are mounted were .01 to .03 inches with reference to bar joist. The deflection was measured with a full weight vehicle (3,200 lbs.). The use of 13 ga. steel for the levitation surface appears satisfactory as far as deflections and strength are concerned. The use of a lighter gauge material would be preferred when the mounting ring for the levitation valve is pressed into the surface. However, vendors feel the 13 ga. material can be formed for the mounting ring. The 13 ga. material appears as the best compromise between strength and formability.

The bar joists in the present design are satisfactory from a strength and deflection viewpoint. However, they should be studied to optimize bar sizes for weight and cost reduction.

The turbine module mounting required a design change. When the turbine modules were shut off and the vehicle delevitated, the pressure in the flexible 5 inch hoses pushed the turbine module into the vehicle buckets and caused interference. The problem was corrected by connecting the lower end of the turbine module bracket to the tension member of the bar joists. A redesign of this bracket and/or turbine module mounting method is desirable for future work.

The joints between sections on the levitation surface have to be smooth and leak proof. Drawings E-00320 and E00476 show the section joint for the guideway. This joint was satisfactory for operation of the vehicle. The joint method produces a problem when removing a damaged section for repair or replacement. Only if the angle fingers are removeable will the section come out, unless several sections before and after the section to be removed are loosened and slid apart. Additional future design work on this joint is necessary.

Another joint was tried between the steel operating surface and the 32 ft. of plywood deck. This joint closely resembles the design shown on Drawing E-00339, which is intended for the expansion joint located at the expansion joint of the structural enclosure. Although there was no expansion involved in the test facility, the vehicle operated over the joint in both directions without encountering any problems.

Several areas of redesign are deemed necessary in the 30 inch main air supply tubes. A design of an easily coupled joint at the 13 ft. 9 in. section joints would be beneficial to simplify field assembly and disassembly.

The 4 inch and 5 inch flexible tubing from the main air supply should have a simpler connection to the main air duct. A rubber molded, snapped-in-place module would be desirable, rather than the soldered nipple and hose clamp arrangement, as was used in the test facility.

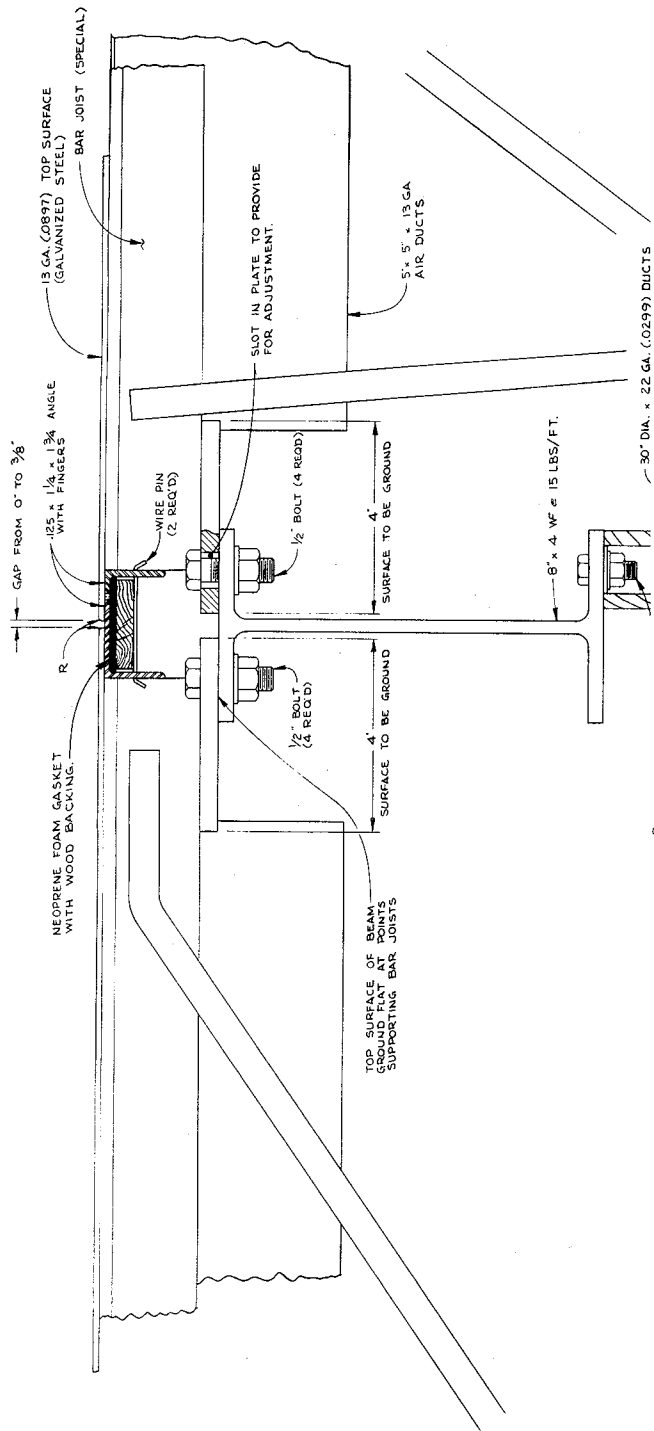

This page is reproduced at the

This page is reproduced at the back of the report by a different reproduction method to provide better detail.

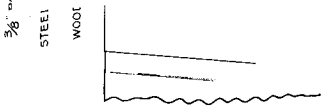

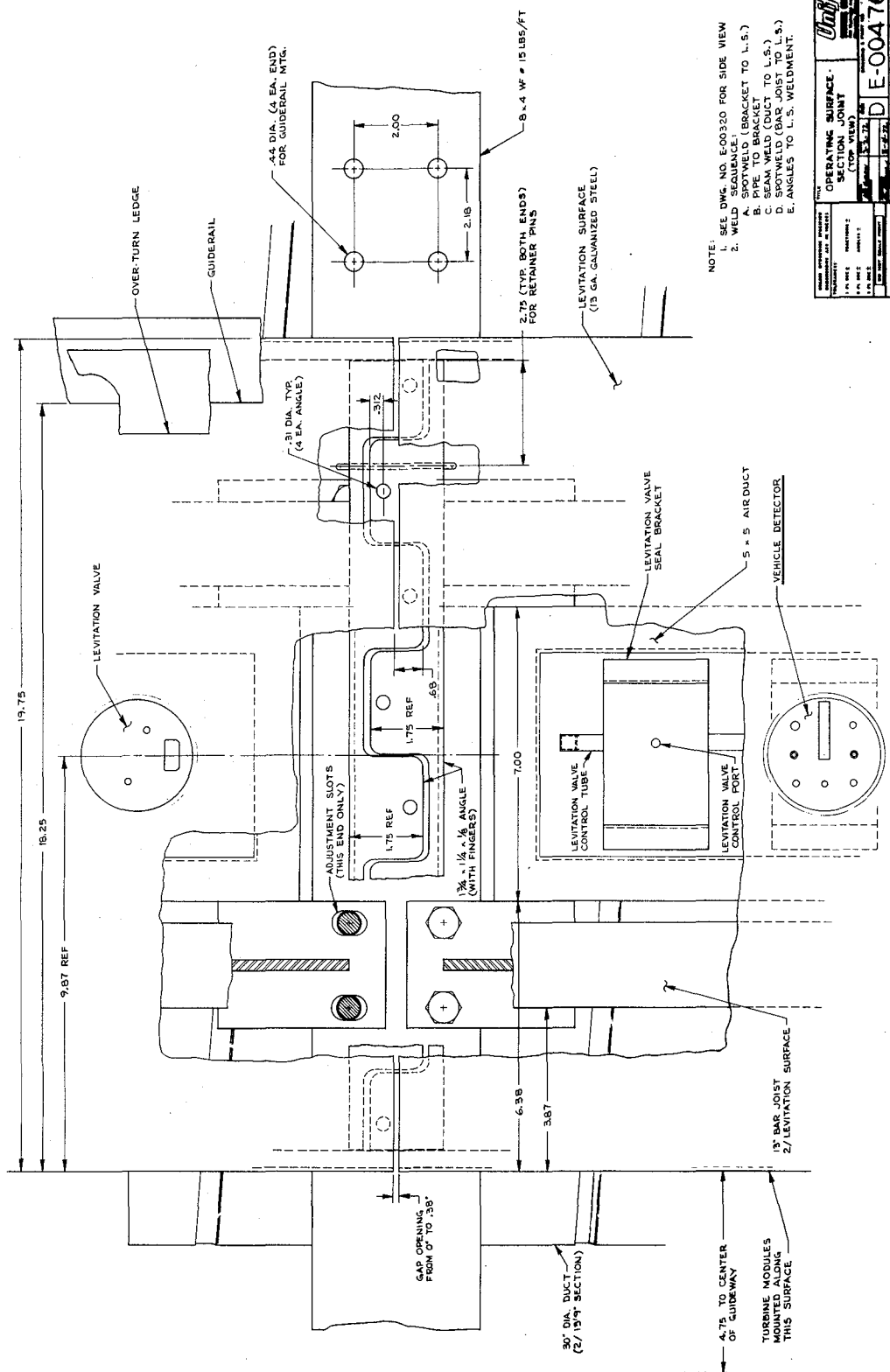

NOTE:
 1. SEE DWG. NO. E-00320 FOR SIDE VIEW
 2. WELD SEQUENCE:
 A. SPOTWELD (BRACKET TO L.S.)
 B. SPAN WELD (BRACKET TO L.S.)
 C. SPAN WELD (BRACKET TO L.S.)
 D. SPOTWELD (BAR JOIST TO L.S.)
 E. ANGLES TO L.S. WELDMENT.

OPERATING SURFACE SECTION JOINT	
DATE	REV.
10/10/54	1
11/10/54	2
12/10/54	3
1/10/55	4
2/10/55	5
3/10/55	6
4/10/55	7
5/10/55	8
6/10/55	9
7/10/55	10
8/10/55	11
9/10/55	12
10/10/55	13
11/10/55	14
12/10/55	15
1/10/56	16
2/10/56	17
3/10/56	18
4/10/56	19
5/10/56	20
6/10/56	21
7/10/56	22
8/10/56	23
9/10/56	24
10/10/56	25
11/10/56	26
12/10/56	27
1/10/57	28
2/10/57	29
3/10/57	30
4/10/57	31
5/10/57	32
6/10/57	33
7/10/57	34
8/10/57	35
9/10/57	36
10/10/57	37
11/10/57	38
12/10/57	39
1/10/58	40
2/10/58	41
3/10/58	42
4/10/58	43
5/10/58	44
6/10/58	45
7/10/58	46
8/10/58	47
9/10/58	48
10/10/58	49
11/10/58	50
12/10/58	51
1/10/59	52
2/10/59	53
3/10/59	54
4/10/59	55
5/10/59	56
6/10/59	57
7/10/59	58
8/10/59	59
9/10/59	60
10/10/59	61
11/10/59	62
12/10/59	63
1/10/60	64
2/10/60	65
3/10/60	66
4/10/60	67
5/10/60	68
6/10/60	69
7/10/60	70
8/10/60	71
9/10/60	72
10/10/60	73
11/10/60	74
12/10/60	75
1/10/61	76
2/10/61	77
3/10/61	78
4/10/61	79
5/10/61	80
6/10/61	81
7/10/61	82
8/10/61	83
9/10/61	84
10/10/61	85
11/10/61	86
12/10/61	87
1/10/62	88
2/10/62	89
3/10/62	90
4/10/62	91
5/10/62	92
6/10/62	93
7/10/62	94
8/10/62	95
9/10/62	96
10/10/62	97
11/10/62	98
12/10/62	99
1/10/63	100
2/10/63	101
3/10/63	102
4/10/63	103
5/10/63	104
6/10/63	105
7/10/63	106
8/10/63	107
9/10/63	108
10/10/63	109
11/10/63	110
12/10/63	111
1/10/64	112
2/10/64	113
3/10/64	114
4/10/64	115
5/10/64	116
6/10/64	117
7/10/64	118
8/10/64	119
9/10/64	120
10/10/64	121
11/10/64	122
12/10/64	123
1/10/65	124
2/10/65	125
3/10/65	126
4/10/65	127
5/10/65	128
6/10/65	129
7/10/65	130
8/10/65	131
9/10/65	132
10/10/65	133
11/10/65	134
12/10/65	135
1/10/66	136
2/10/66	137
3/10/66	138
4/10/66	139
5/10/66	140
6/10/66	141
7/10/66	142
8/10/66	143
9/10/66	144
10/10/66	145
11/10/66	146
12/10/66	147
1/10/67	148
2/10/67	149
3/10/67	150
4/10/67	151
5/10/67	152
6/10/67	153
7/10/67	154
8/10/67	155
9/10/67	156
10/10/67	157
11/10/67	158
12/10/67	159
1/10/68	160
2/10/68	161
3/10/68	162
4/10/68	163
5/10/68	164
6/10/68	165
7/10/68	166
8/10/68	167
9/10/68	168
10/10/68	169
11/10/68	170
12/10/68	171
1/10/69	172
2/10/69	173
3/10/69	174
4/10/69	175
5/10/69	176
6/10/69	177
7/10/69	178
8/10/69	179
9/10/69	180
10/10/69	181
11/10/69	182
12/10/69	183
1/10/70	184
2/10/70	185
3/10/70	186
4/10/70	187
5/10/70	188
6/10/70	189
7/10/70	190
8/10/70	191
9/10/70	192
10/10/70	193
11/10/70	194
12/10/70	195
1/10/71	196
2/10/71	197
3/10/71	198
4/10/71	199
5/10/71	200
6/10/71	201
7/10/71	202
8/10/71	203
9/10/71	204
10/10/71	205
11/10/71	206
12/10/71	207
1/10/72	208
2/10/72	209
3/10/72	210
4/10/72	211
5/10/72	212
6/10/72	213
7/10/72	214
8/10/72	215
9/10/72	216
10/10/72	217
11/10/72	218
12/10/72	219
1/10/73	220
2/10/73	221
3/10/73	222
4/10/73	223
5/10/73	224
6/10/73	225
7/10/73	226
8/10/73	227
9/10/73	228
10/10/73	229
11/10/73	230
12/10/73	231
1/10/74	232
2/10/74	233
3/10/74	234
4/10/74	235
5/10/74	236
6/10/74	237
7/10/74	238
8/10/74	239
9/10/74	240
10/10/74	241
11/10/74	242
12/10/74	243
1/10/75	244
2/10/75	245
3/10/75	246
4/10/75	247
5/10/75	248
6/10/75	249
7/10/75	250
8/10/75	251
9/10/75	252
10/10/75	253
11/10/75	254
12/10/75	255
1/10/76	256
2/10/76	257
3/10/76	258
4/10/76	259
5/10/76	260
6/10/76	261
7/10/76	262
8/10/76	263
9/10/76	264
10/10/76	265
11/10/76	266
12/10/76	267
1/10/77	268
2/10/77	269
3/10/77	270
4/10/77	271
5/10/77	272
6/10/77	273
7/10/77	274
8/10/77	275
9/10/77	276
10/10/77	277
11/10/77	278
12/10/77	279
1/10/78	280
2/10/78	281
3/10/78	282
4/10/78	283
5/10/78	284
6/10/78	285
7/10/78	286
8/10/78	287
9/10/78	288
10/10/78	289
11/10/78	290
12/10/78	291
1/10/79	292
2/10/79	293
3/10/79	294
4/10/79	295
5/10/79	296
6/10/79	297
7/10/79	298
8/10/79	299
9/10/79	300
10/10/79	301
11/10/79	302
12/10/79	303
1/10/80	304
2/10/80	305
3/10/80	306
4/10/80	307
5/10/80	308
6/10/80	309
7/10/80	310
8/10/80	311
9/10/80	312
10/10/80	313
11/10/80	314
12/10/80	315
1/10/81	316
2/10/81	317
3/10/81	318
4/10/81	319
5/10/81	320
6/10/81	321
7/10/81	322
8/10/81	323
9/10/81	324
10/10/81	325
11/10/81	326
12/10/81	327
1/10/82	328
2/10/82	329
3/10/82	330
4/10/82	331
5/10/82	332
6/10/82	333
7/10/82	334
8/10/82	335
9/10/82	336
10/10/82	337
11/10/82	338
12/10/82	339
1/10/83	340
2/10/83	341
3/10/83	342
4/10/83	343
5/10/83	344
6/10/83	345
7/10/83	346
8/10/83	347
9/10/83	348
10/10/83	349
11/10/83	350
12/10/83	351
1/10/84	352
2/10/84	353
3/10/84	354
4/10/84	355
5/10/84	356
6/10/84	357
7/10/84	358
8/10/84	359
9/10/84	360
10/10/84	361
11/10/84	362
12/10/84	363
1/10/85	364
2/10/85	365
3/10/85	366
4/10/85	367
5/10/85	368
6/10/85	369
7/10/85	370
8/10/85	371
9/10/85	372
10/10/85	373
11/10/85	374
12/10/85	375
1/10/86	376
2/10/86	377
3/10/86	378
4/10/86	379
5/10/86	380
6/10/86	381
7/10/86	382
8/10/86	383
9/10/86	384
10/10/86	385
11/10/86	386
12/10/86	387
1/10/87	388
2/10/87	389
3/10/87	390
4/10/87	391
5/10/87	392
6/10/87	393
7/10/87	394
8/10/87	395
9/10/87	396
10/10/87	397
11/10/87	398
12/10/87	399
1/10/88	400
2/10/88	401
3/10/88	402
4/10/88	403
5/10/88	404
6/10/88	405
7/10/88	406
8/10/88	407
9/10/88	408
10/10/88	409
11/10/88	410
12/10/88	411

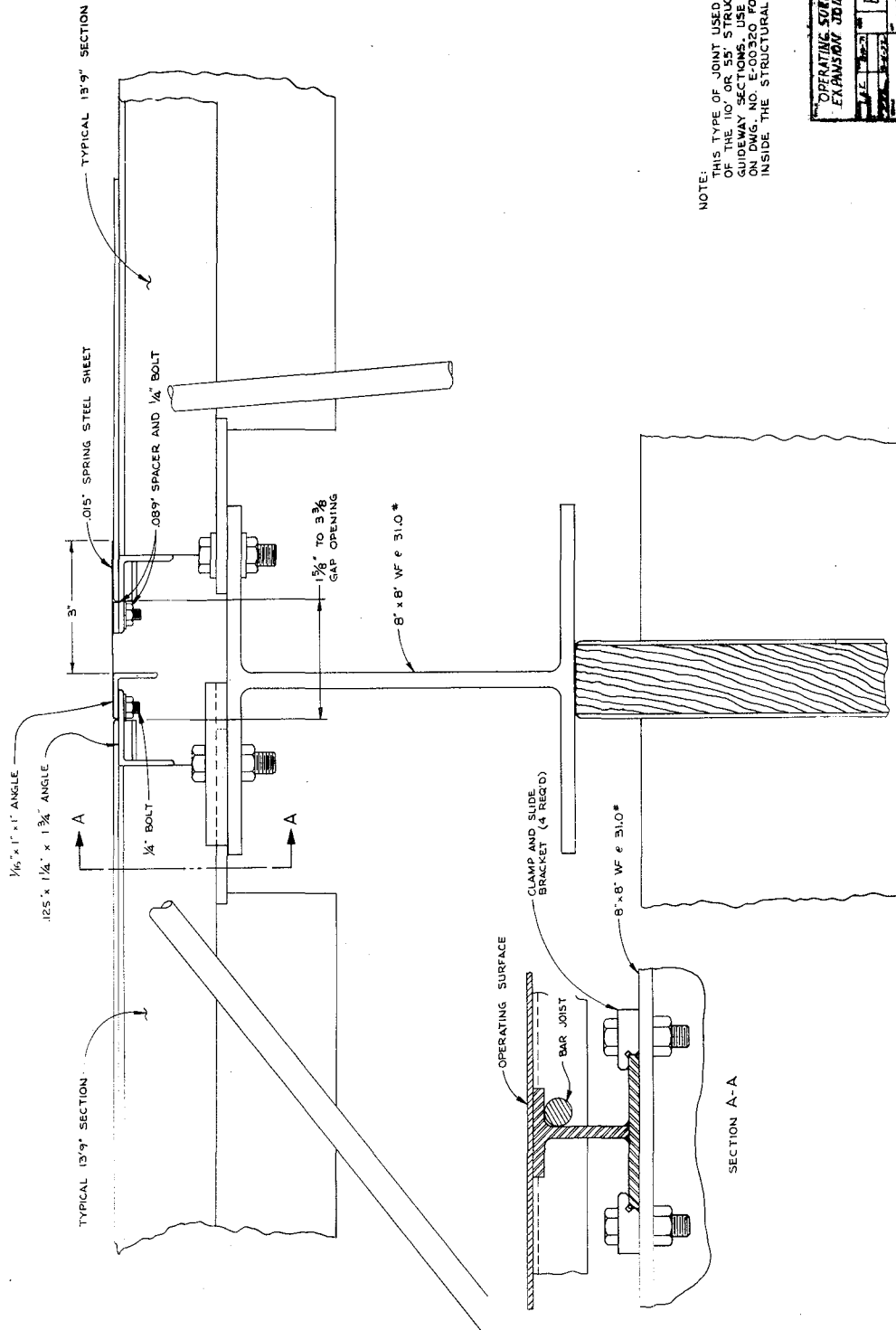

NOTE: THIS TYPE OF JOINT USED AT THE JOINTS ON THE JOINTS OF STRUCTURAL GUIDEWAY SECTIONS USE JOINTS SHOWN ON DWG. NO. E-00320 FOR JOINTS INSIDE THE STRUCTURAL GUIDEWAY.

OPERATING SURFACE EXPANSION JOINT	
DATE	E-00320
BY	
CHECKED	
APPROVED	

1.3 TURBINE MODULE DESIGN AND CONSTRUCTION

The propulsion unit for the Uniflo system is a linear air turbine. The design and configuration have been under development for several years. The object of this contract was to construct enough of the modules to measure full-scale performance. To provide this data, 40 units were constructed, and 36 installed in the 55 ft. steel operating surface.

Drawing E-00465 shows the general configuration of the module. The basic shell and buckets are made from polyester fiber glass. The diaphragms are made from neoprene rubber, and the smaller plastic parts are made from phenolic. The assembly is riveted together and sealed with silicone rubber. Some of the tooling for the parts existed, such as the plenum halves and buckets. The additional tooling was made under the contract.

The turbine module was designed before the contract. However, an amplifier valve was designed which would amplify the levitation pad pressure signal to a level to operate the main poppet valve. This design uses parts and principles of operation used in the levitation valves. Performance of the turbine module is discussed in Section 6.0 of this report. In summary, the thrust produced by the modules for the whole vehicle is 250 lbs. static, with a fall-off with speed to 200 lbs. at 19 ft./sec. Thrust levels higher than this are desirable, and with changes in valve shapes, nozzle area, bucket shapes, thrust levels over 360 lbs. static are expected. Future work on the turbine module is required to produce higher thrust levels and to generally acquire more information on its operation.

Another future area of turbine module design is to examine changes which would produce less noise. This would probably be more productive from a cost effectiveness standpoint than guideway enclosure designs for noise reduction.

1.4 CONTROL SYSTEM

The control system for the test facility was very elemental. It consisted of the ability to inhibit levitation valves, enable the forward turbine modules, and enable the reverse modules. An interlock was provided to make sure the vehicle either had full thrust or emergency braking upon return from the vehicle arresting mechanism.

Drawing E-00523 shows the schematic drawing. Electric solenoid valves were used for conversion of electric to pneumatic signals required for the operation of the levitation valves and turbine modules.

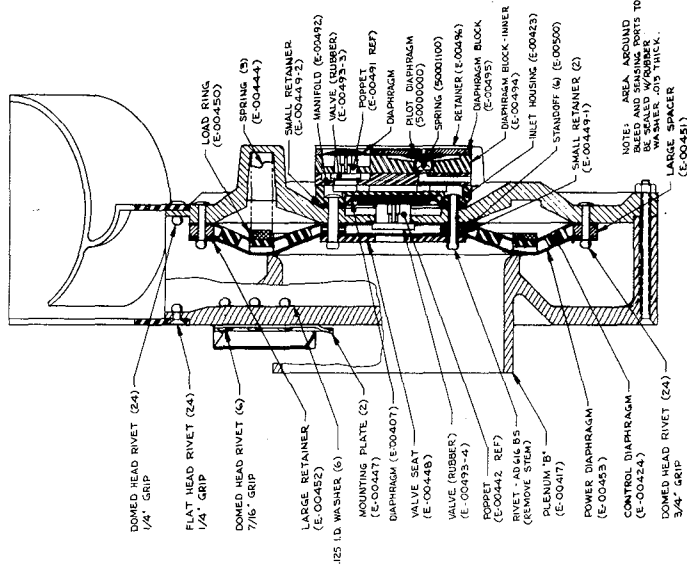
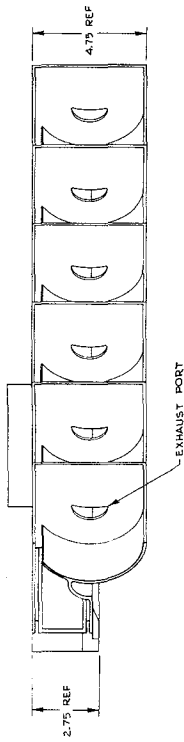

SECTION A-A
SCALE: 1/1

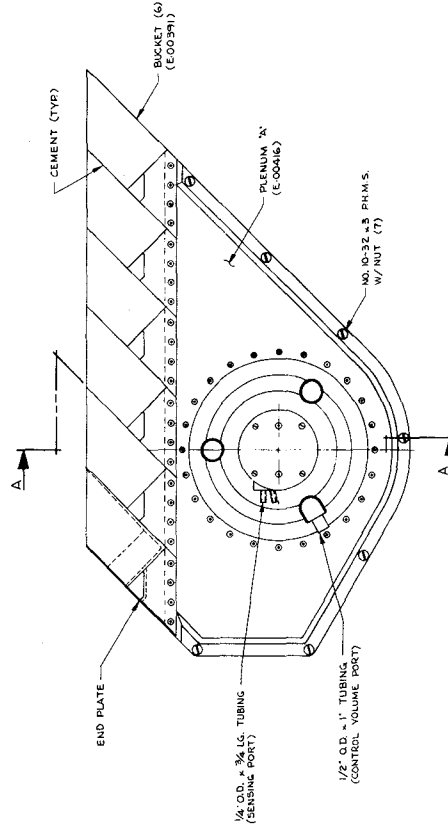

UNION	
TURBINE MODULE ASSEMBLY	
REV	DATE
1	10-1-57
2	10-1-57
3	10-1-57
4	10-1-57
5	10-1-57
6	10-1-57
7	10-1-57
8	10-1-57
9	10-1-57
10	10-1-57
11	10-1-57
12	10-1-57
13	10-1-57
14	10-1-57
15	10-1-57
16	10-1-57
17	10-1-57
18	10-1-57
19	10-1-57
20	10-1-57
21	10-1-57
22	10-1-57
23	10-1-57
24	10-1-57
25	10-1-57
26	10-1-57
27	10-1-57
28	10-1-57
29	10-1-57
30	10-1-57
31	10-1-57
32	10-1-57
33	10-1-57
34	10-1-57
35	10-1-57
36	10-1-57
37	10-1-57
38	10-1-57
39	10-1-57
40	10-1-57
41	10-1-57
42	10-1-57
43	10-1-57
44	10-1-57
45	10-1-57
46	10-1-57
47	10-1-57
48	10-1-57
49	10-1-57
50	10-1-57
51	10-1-57
52	10-1-57
53	10-1-57
54	10-1-57
55	10-1-57
56	10-1-57
57	10-1-57
58	10-1-57
59	10-1-57
60	10-1-57
61	10-1-57
62	10-1-57
63	10-1-57
64	10-1-57
65	10-1-57
66	10-1-57
67	10-1-57
68	10-1-57
69	10-1-57
70	10-1-57
71	10-1-57
72	10-1-57
73	10-1-57
74	10-1-57
75	10-1-57
76	10-1-57
77	10-1-57
78	10-1-57
79	10-1-57
80	10-1-57
81	10-1-57
82	10-1-57
83	10-1-57
84	10-1-57
85	10-1-57
86	10-1-57
87	10-1-57
88	10-1-57
89	10-1-57
90	10-1-57
91	10-1-57
92	10-1-57
93	10-1-57
94	10-1-57
95	10-1-57
96	10-1-57
97	10-1-57
98	10-1-57
99	10-1-57
100	10-1-57

1.5 AIR SUPPLY

The air supply consists of a 150 HP electric motor/centrifugal blower combination. The blower is a standard unit manufactured by Buffalo Forge Co., Buffalo, New York. Figure 1-3 shows the performance curves supplied by the manufacturer. Two curves are shown; one with variable inlet vanes open, and the other with the inlet vanes turned to cause a downward sloping pressure versus flow curve. This flow pressure curve will produce stable operation at very low flows. Even though blowers have backward curved blades, most centrifugal blowers show an increased pressure with flow at their low flow conditions when variable inlet vanes are not used.

From the blower to the guideway, 22" diameter double-wall tubing carried the air. The inner wall of the tubing was perforated, and the gap was filled with fiber glass. This type of construction reduced the sound level of the blower. Installed in the tube was an orifice plate of 11" diameter, which measured the air flow. Unfortunately, the orifice plate caused a pressure drop of 8 to 10 inches of water at running conditions. Because of this drop, the variable inlet vanes were opened slightly, and the blower would surge at low flows (levitation only).

A filter was provided on the inlet. The length of the inlet pipe was short so the sound was not attenuated appreciably. Because of this, the inlet was disconnected at the blower and outside air was used during the sound tests. This reduced the background noise. Commercially available silencers installed on the blower can silence the blower noise.

Power to the motor was 460 Volt, 3 phase. A 160KW power meter monitored the power consumption.

Figure 1-4 shows a photograph of the blower installation.

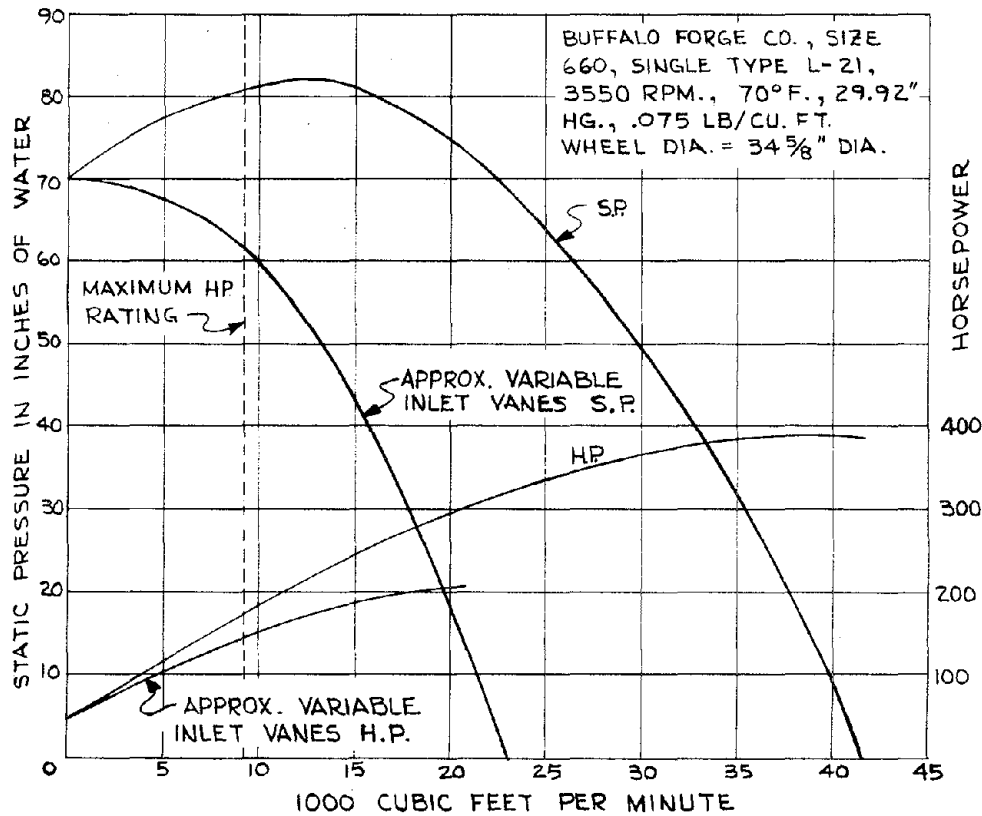

Figure 1-3. Blower Performance Curves

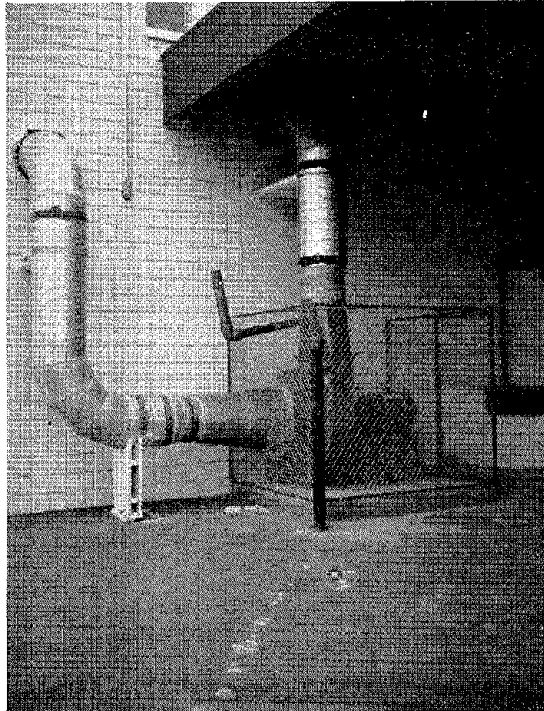

Figure 1-4, 150 HP Blower and Motor Installation

This page is reproduced at the back of the report by a different reproduction method to provide better detail.



2.0 FULL SCALE TEST VEHICLE

2.1 BACKGROUND

Under this item of the contract, Uniflo Systems Company was to provide an 8-passenger vehicle with production prototype turbine buckets, levitation pads, and emergency brake skids. At the beginning of the contract, Uniflo had an operational 44" gauge vehicle, the base of which was to be modified to bring it up to the conditions of the contract. The superstructure shown in Drawing E-00522 was unmodified. Drawing E-00505 generally shows many of the modifications made to the vehicle base.

In particular, the items requiring attention were:

1. Modify pad base to the latest design configuration.
2. Mold new pads of 40 durometer neoprene.
3. Install brake skids of .4 friction coefficient.
4. Improve pad interconnect system to eliminate leaks and interface with the new pad base design.
5. Increase the gauge width to 46".
6. Design a suitable secondary suspension to connect the vehicle superstructure to the base.
7. Design and install turbine buckets.
8. Install acoustical baffles over the turbine exhaust ports.

All of the above items were satisfactorily completed under the contract, and are described below.

2.2 VEHICLE DESCRIPTION

The original pad base is shown in Drawing E-00227. It was determined by previous analysis and experiment that this configuration was causing stability problems, and should be changed to the configuration shown in Drawing E-00505. In this modification, most of the inner plate was removed with only enough left to retain the outer bead of the pad. A preferred construction is shown on Drawing E-00528. However, tooling costs for stampings prohibited the use of this design for the production prototype. The above modifications reduced the levitation height 3/8", so 3/8" plywood spacers were installed between the pads and the vehicle, as can be seen on Drawing E-00505.

It was observed that the existing pads made of nitrile rubber were taking a set and getting harder with age. This resulted in stability problems. For this contract, new pads were molded, using 40 durometer neoprene. The usual Hughson Z-306 urethane coating was applied to the outside of the pad to reduce wear and friction.

The existing vehicle was equipped with HMW polyethylene (Hercules 1900) brake skids with a friction coefficient of about .2. For the emergency braking tests, skids of about .4 friction coefficient were also needed. The material selected was Raybestos.R-3375-0, which is an asbestos rubber-bonded, heavy-duty material containing brass chips. Friction coefficient is .43. The Hercules 1900 and the R-3375-0 are of different thickness, so the brake shims were adjusted accordingly.

The existing pad interconnect system necessary for load sharing between the levitation pads was prone to leaking, due to the use of compression-type seals at the vehicle pad interface. The entire interconnect system was replaced, using 3/4" PVC pipe and insert fittings. The piping schematic and details are shown in Drawing E-00532 and E-00534. In addition to the interconnect plumbing, an outlet vent was installed on each pad to provide air for the future air conditioning system. The outlets are sized to supply 1/4 cfs. air from each pad. A simple pop-out valve shown in Drawing E-00509, was designed to be installed on each air conditioning outlet. They are positioned so that at low pad pressure the steel slug falls and blocks the opening. At operating pressure, the slug is forced up and out of the way. This sealing of the pad is required for reliable restart.

The changing of the vehicle gauge to 46" was done by installing 1" shim packs under the roller mounts on each side of the vehicle (E-00505). The shims are in 1/16" increments, and were changed to

Preceding page blank

shift the vehicle laterally for the test of turbine performance fall-off with misalignment.

The superstructure is mated to the vehicle base using Lord mounts. As shown in Drawings E-00522 and E-00505, four suspension mounts were made up and bolted to the underside of the superstructure floor. The eight Lord mounts were then positioned as shown in Drawing E-00505. Lord mounts JM-5425-15 were used with a spring rate of 175 lb./inch. This gives an empty natural frequency of 2 3/4 cps, and a loaded frequency of 2 cps. JM-5424-30 with a spring rate of 250 lb./inch were purchased for back-up. Volkswagen steering shimmy dampers, Part No. Z11415-901F are used for damping in all three axis. Drawing E-00530 shows the installation. The change in mounting of the superstructure required strengthening of the floor in several areas. In particular, splice plates were installed at a center joint, and stiffeners were installed in walk areas.

The turbine buckets designed for this contract are shown in Drawing E-00497. The design shape of the bucket is similar to previous designs, except for the radius on the inlet edge to improve performance when the vehicle and guideway halves of the turbine are misaligned laterally. The buckets are compression molded of polyester premix, with a 15% glass content. Temporary aluminum tooling was made under the contract. A bucket assembly was built up by pop riveting the buckets to aluminum extrusions. The whole assembly was then riveted into the vehicle as shown in Drawing E-00501. The buckets are installed with a 1/8" clearance from the guideway in the delevitated position.

Figure 2-1 is a view of the bottom of the vehicle showing levitation pads, brake shoes, and turbine buckets.

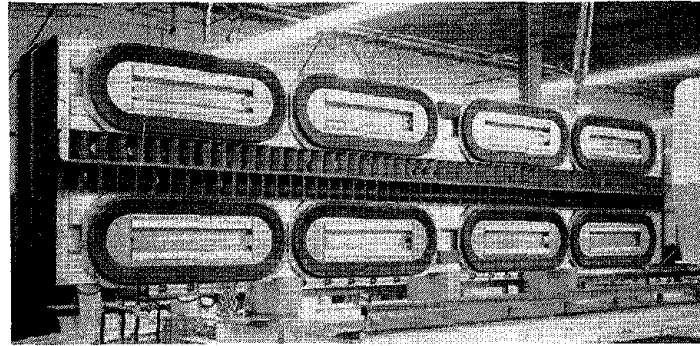

Figure 2-1. Vehicle Bottom

Acoustical baffles were installed in the vehicle above the turbine exhaust ports as shown in Figure 2-2. Sound absorption is obtained with a lead-foam sandwich. This was built up using 1/4" urethane foam with adhesive on both sides—1 lb./ft.² lead sheet, and 3/4" urethane foam with adhesive on one side. The installation of this baffling had no measurable affect on sound levels outside the vehicle, and only 1 to 2 DBA inside the vehicle.

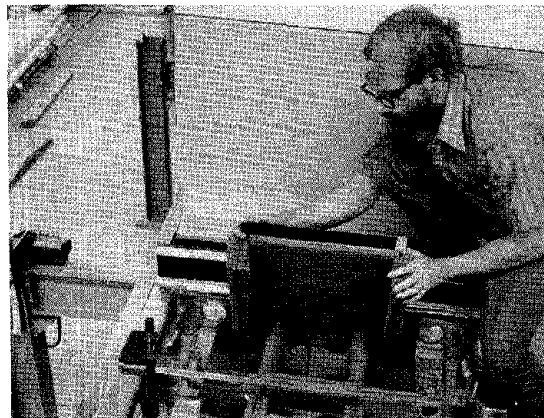

Figure 2-2. Acoustical Baffling

In conjunction with the contract, USC made some minor additions to the superstructure. A hoist arrangement was built up which allowed the vehicle to be picked up and rotated 90° for maintenance on the bottom of the vehicle (Figure 2-3). Light-weight boxes were made and loaded to 212 lbs. each to represent the useful load of 1,700 lbs. Load boxes were hoisted in as shown in Figure 2-4. Finally, a pneumatically actuated door lock was installed. The piston and pin arrangement is activated by pad pressure so that the door is locked when the vehicle is levitated.



Figure 2-3. Vehicle Rotated 90° for Maintenance

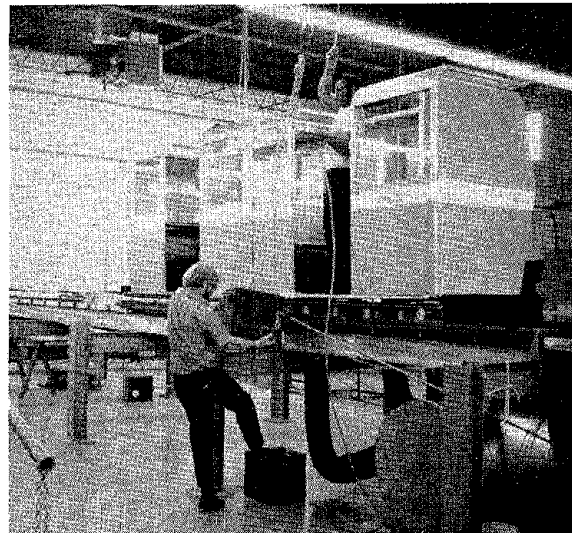
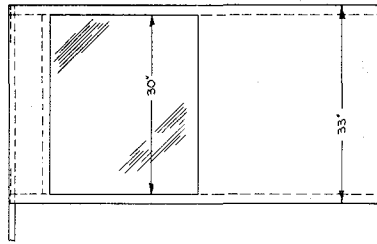
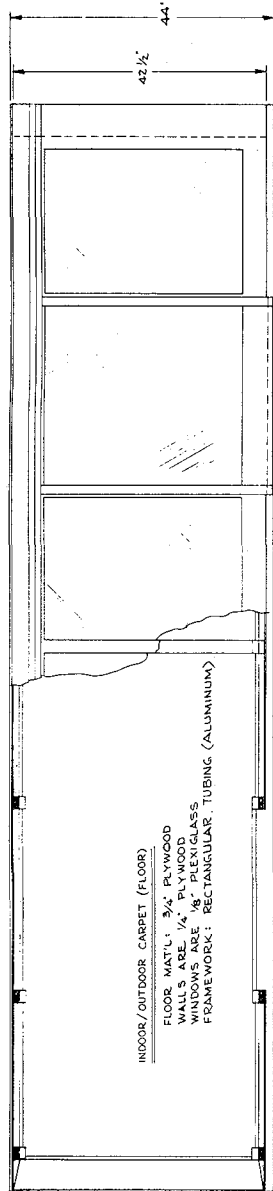
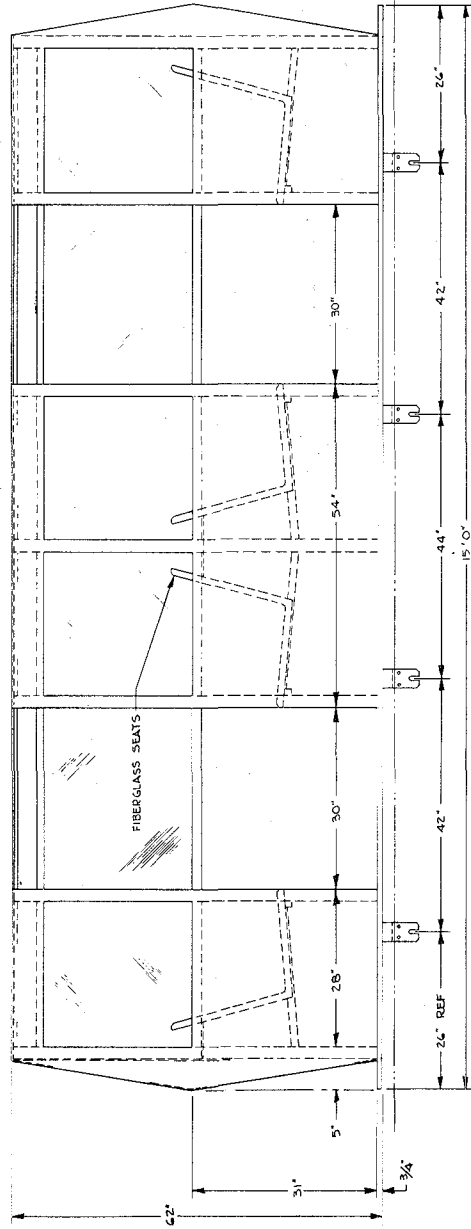

Figure 2-4. Load Boxes entering Vehicle

This page is reproduced at the back of the report by a different reproduction method to provide better detail.



DOOR (NOT SHOWN IN PLACE)
 MAT'L:
 1/2" PLYWOOD
 1/2" ALUMINUM
 1/2" x 3/4" AL. TUBING



SIDE ELEVATION
 (DOORS NOT IN PLACE)

CONTRACT NO. DOT-TSC-367

UNIFLO VEHICLE PROTOTYPE MOCKUP	UNIFLO
PROJECT NO. E00522	DATE 1/27/78
BY [Signature]	BY [Signature]
CHECKED [Signature]	CHECKED [Signature]
DATE 1/27/78	DATE 1/27/78

is rep
 on e
 in
 the

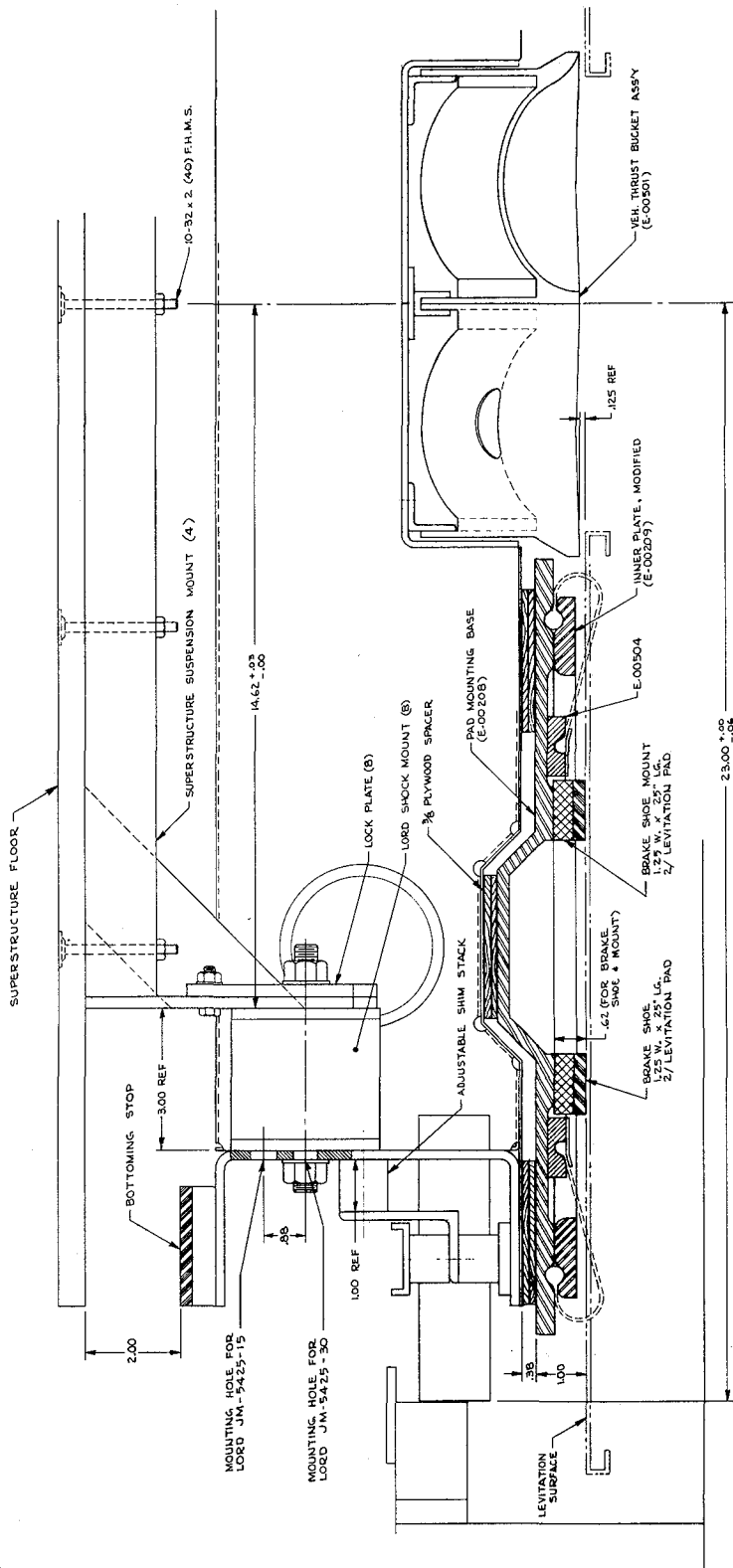

CONTRACT NO. DOT-TSC-367

VEHICLE BASE MODIFICATIONS			E-00505 REV. 1 DATE 11/15/67
PART NO. 1 QTY. 1 PART NO. 2 QTY. 1	PART NO. 3 QTY. 1 PART NO. 4 QTY. 1		

REV	DATE	DESCRIPTION	BY	CHK
A		Customer Change Order		

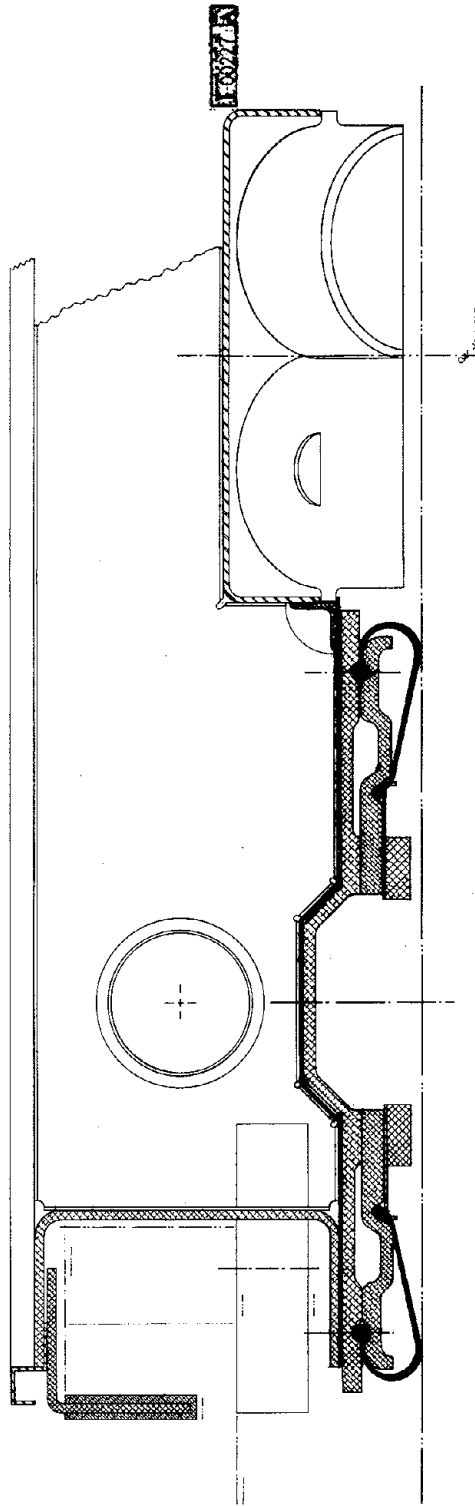

Uniflo UNIFORM COMPANY	
Vehicle Base Section Cross Section (Cast Aluminum Rio Base)	DATE: 1/27/70
1-28-70	VP
D E-0027A	
SCALE: FULL	FIG. 3

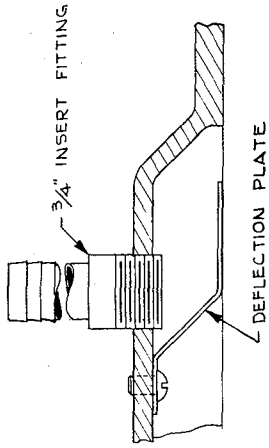

SECTION A-A
SCALE: 1/1
(SIGNAL OUTPUT PORT)

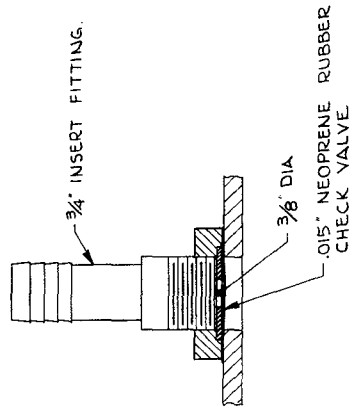

SECTION B-B
ROTATED 90° CCW
SCALE: 1/1
(SIGNAL INPUT PORT)

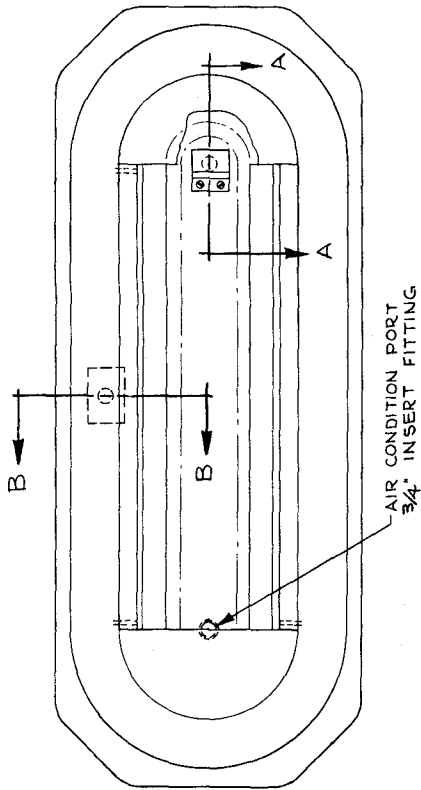

BOTTOM VIEW
SCALE: 1/4

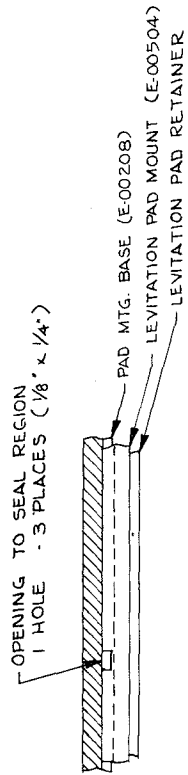

DETAIL C
SCALE: 1/1

CONTRACT NO. DOT-TSC-367

UNIFORM DRAWING SPECIFICATIONS		UNIFORM DRAWING SPECIFICATIONS	
UNITS: DIMENSIONS ARE IN INCHES		UNITS: DIMENSIONS ARE IN INCHES	
TOLERANCES:		TOLERANCES:	
1. FIT MFG.	FRACTIONS: 2	TITLE	
2. FIT MFG.	DECIMALS: 2	LEVITATION PAD INTERCONNECTING HARDWARE	
3. FIT MFG.	ANGLES: 2	UNIFLO SYSTEMS COMPANY	
4. FIT MFG.	DO NOT SCALE DRAWING	DRAWING & PART NO.	
		C E-00532	
		SCALE NOTED	

FRONT OF VEHICLE

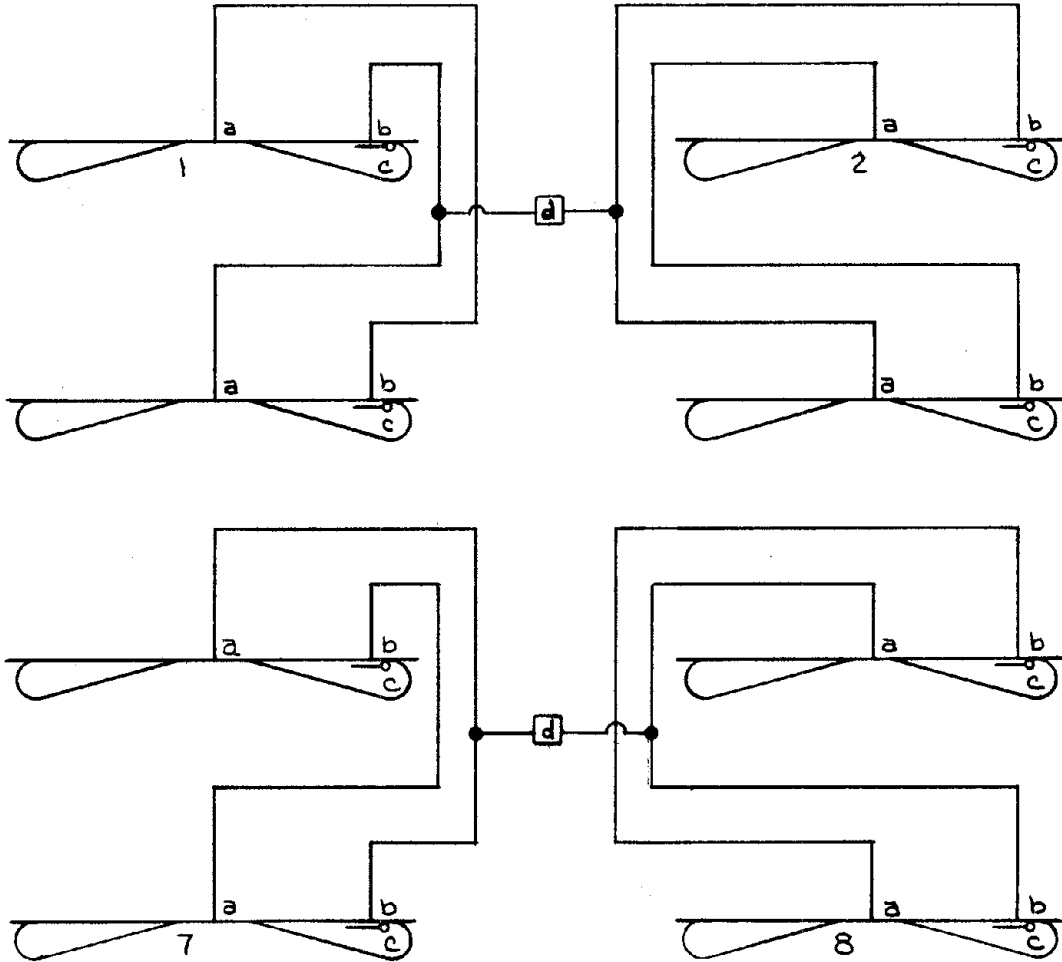

a. - SIGNAL OUTPUT
b. - SIGNAL INPUT

c. - CHECK VALVE
d. - 1" BALL VALVE

UNLESS OTHERWISE SPECIFIED DIMENSIONS ARE IN INCHES TOLERANCES 1 PL DEC ± FRACTIONS ± 2 PL DEC ± ANGLES ± 3 PL DEC ±	TITLE 8-PAD INTERCONNECT SCHEMATIC		 SYSTEMS COMPANY 7401 Washington Avenue South Minneapolis, Minnesota 55423	
	CONTRACT NO. DOT-TSC-367	DRAWING & PART NO. A E-00534	DATE 8-22-72	REV
DO NOT SCALE PRINT CONTRACT NO. DOT-TSC-367	APPROVED SCALE NONE	SIZE A	DRAWING & PART NO. A E-00534	REV
	SCALE NONE	WT	SHEET	OF

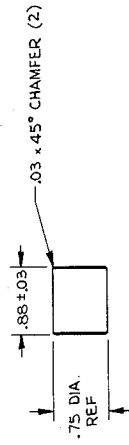
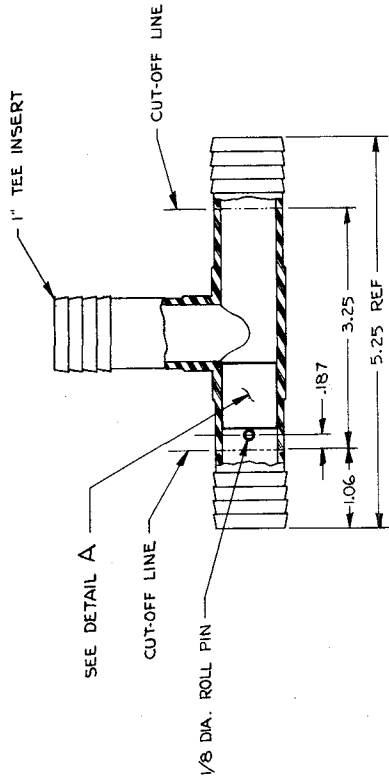
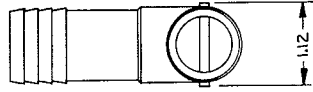

DETAIL A
MAT'L: 3/4" DIA. GROUND STEEL ROD.

DESIGN APPROVED BY: [Signature] DATE: 11-15-72 DRAWN BY: [Signature]		Uniflo SYSTEMS COMPANY 1000 W. 10th Street, Suite 100 Denver, Colorado 80202	
TITLE: AIR-CONDITIONING POP-OUT VALVE		SIZE: C	SHEET NO: E-00509
1 PL. INC 2 2 PL. INC 2 2 PL. INC 2 2 PL. INC 2		SCALE: 1/1	UNIT:
100 NOT SCALE PRINT		DATE:	SHEET:

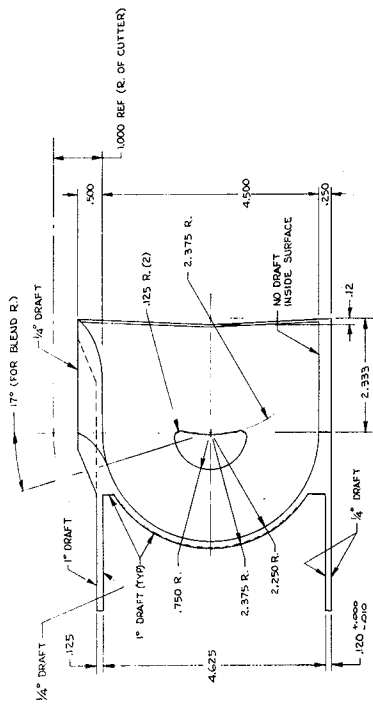

DIMENSIONS THIS VIEW FOR TOP SURFACE ONLY

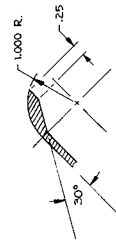
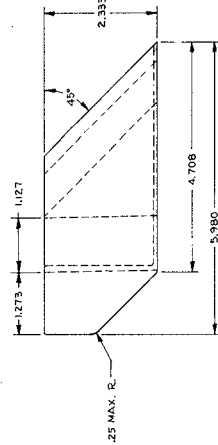
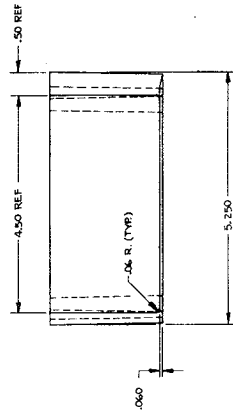

MATL: POLYESTER HOLDING COMPOUND

CONTRACT NO. DOT-TSC-367

PROJECT NAME (NUMBER)	CONTRACT NO. DOT-TSC-367
DRAWING NO. E-00497	DATE 11/27/73
DESIGNED BY (NAME)	CHECKED BY (NAME)
DRAWN BY (NAME)	APPROVED BY (NAME)

Other equipment used for measuring the sound pressure levels was:

- Kudelski (NAGRA) precision portable tape recorder
- Bruel and Kjaer impulse precision sound level meter model 2204
- Bruel and Kjaer 1" microphone model 4145
- Tripod and 3 meter cable
- Piston phone model 4220
- Nose cone model UA 0051

For analysis of recorded data, the following equipment was used:

- Kudelski (NAGRA) precision tape recorder
- Bruel and Kjaer 1/3 octave band filter model 1612
- Bruel and Kjaer impulse precision sound level meter model 2204
- Bruel and Kjaer high speed level recorder model 2304

In order to determine the location of the 25 ft. point along the guideway, a small sound level meter (dBA) was held at several positions along the guideway with the vehicle levitated. The point of highest dBA value was chosen for the further tests.

After determining the location of the 25 ft. point as outlined above, the car was moved to the end of the track and the ILG calibrated reference sound source placed on the track at the former car position. The microphone, equipped with the nose cone, was located at the selected 25 ft. point on a tripod with the microphone located 4.5 ft. from the floor and diaphragm horizontal. See Figure 3-1 for equipment set-up at the 25 ft. point. The microphone was connected by the 3-meter extension cable to the sound level meter, output of which was fed to the 1/3 octave band analyzer. The system was calibrated at 124 dB with the piston phone, and adjusted for atmospheric pressure.

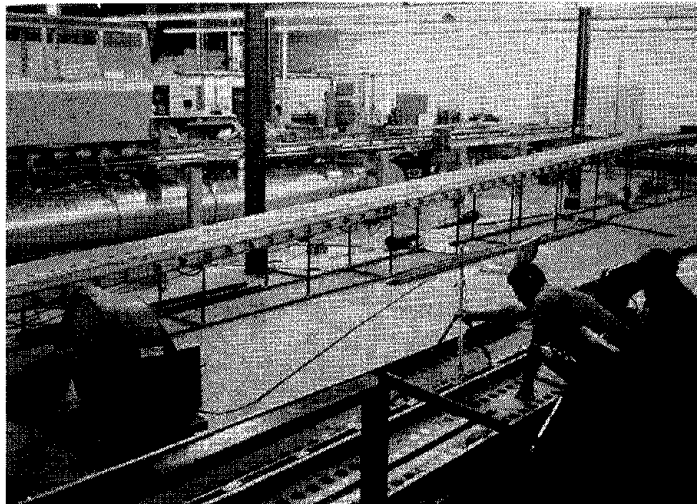

Figure 3-1. Sound equipment set up at the 25 foot point.

3.0 SYSTEM NOISE EMISSIONS

3.1 BACKGROUND

The Uniflo system uses low pressure air for levitation and propulsion. The air flow inherently generates noise. The purpose of the contract work was to measure the level and frequency distribution of these noises, and recommend solutions and costs of the noise control. The noise levels were measured under full acceleration, deceleration and levitation at two points; one, 25 ft. from the vehicle, and two, inside the vehicle. From this data the type of required sound control materials was determined. The costs were estimated for these materials.

3.2 TESTING METHODS

The acoustical testing, data reduction and analysis was performed by the International Acoustical Testing Laboratories, Inc. (Intest), Post Office Box 8049, St. Paul, Minnesota 55113. The measurements of steady sound pressure levels such as background noise were measured directly in 1/3 octave bands at the Uniflo test facility. The sound pressure levels of the acceleration, deceleration, and levitation runs were recorded on magnetic tape, and reduced later at the Intest facility.

Originally, the sound power level of the vehicle was to be calculated from the acoustical room constant and the vehicle sound pressure levels. The sound pressure level of a free field would then be calculated. This was to represent measurement of the sound pressure levels in the out-of-doors as would be typical for the Uniflo system. In addition, measurement of the sound pressure levels at 15 ft. and 25 ft. from the guideway was to be used for determination of the directivity (Q). However, the difference of the sound pressure levels at the 25 ft and 15 ft. positions were too small to give good results for the value of Q.

Alternatively, to calculate sound pressure levels in free field, the sound level of the vehicle was determined by the substitution method. This involved measurement of sound pressure levels at the 25 ft. point with the vehicle on the guideway and at the same 25 ft. point when the ILG (calibrated sound power source) replaced the vehicle on the guideway. The substitution equation is as follows:

$$PWL_V = PWL_I + SPL_V - SPL_I$$

where: subscripts V and I refer to the vehicle and ILG respectively.

For finding sound pressure level in a free field (SPL_F) at 25 ft. from the vehicle, PWL_V was inserted in the following formula.

$$SPL_F = PWL_V + 10 \log_{10} \left(\frac{Q}{4\pi r^2} \right)$$

In this formula, Q has been taken as unity rather than as 2 since the vehicle is to be 15 ft. above the ground, and r is 25 feet.

The reference sound power source was an ILG calibrated reference sound source of which the sound power output has been determined at Armour Research Foundation by the reverberation technique and which has been calibrated periodically in the Intest reverberation chamber and which was again calibrated prior to the Uniflo measurements. For the calibration and the measurements the line voltage was 115 volts - 60 Hz.

Preceding page blank

With the ILG operating at full power and 115 Volts, sound level measurements were determined in 1/3 octave bands from 31.5 Hz to 8,000 Hz.

At the 25 ft. location the microphone was set up connected to the sound level meter and fed to the tape recorder by appropriate cables. A calibration signal from the piston phone was recorded as a reference point. The noise levels emitted during the following runs were recorded.

- a. Empty vehicle, levitated but at rest
- b. Fully loaded vehicle, levitated but at rest
- c. Empty vehicle, cycled through an acceleration and dynamic braking (deceleration) run.
- d. Fully loaded vehicle, cycled through an acceleration and deceleration.

Then the recorder and microphone were installed in the vehicle with an operator, and the runs (a through d) repeated and the noise levels in the vehicle recorded. See Figure 3-2 for the equipment set-up in the vehicle.

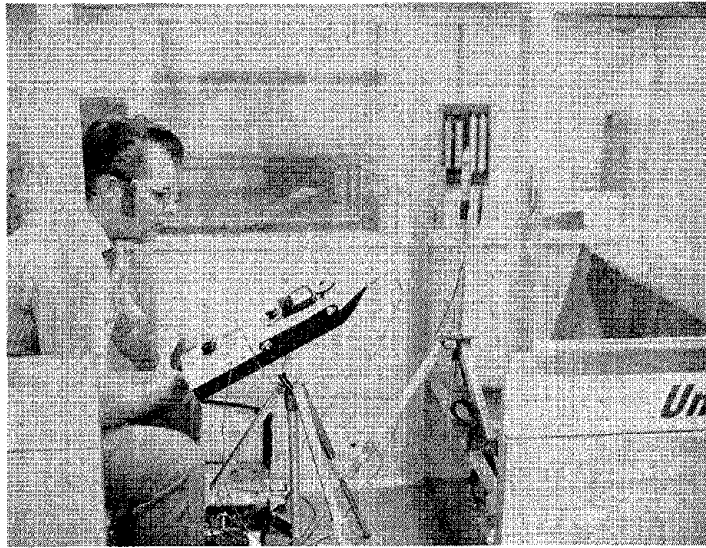

Figure 3-2. Sound equipment set-up in the vehicle.

Before the recording of the test conditions, a determination of the background noise was made using the sound level meter and the 1/3 octave filter directly. This determination was made at the 25 ft. point and in the vehicle with the blower on, but no vehicle or equipment in operation. Further, the background noise at the 25 ft. point was determined with the blower also off.

3.3 DATA REDUCTION AND DISCUSSION

The background levels directly recorded are plotted in Figure 3-3. The sharp peak at 1,000 Hz is the blade passage frequency of the blower. Also plotted on the graph are the NCA 50, 60 and 70 noise criteria curves. The NCA curves have been reduced by 4.9 dB from the octave band curves given in Beranek¹, since the Uniflo plots are in 1/3 octave bands.

This page is reproduced at the back of the report by a different reproduction method to provide better detail.

¹P. 520, *Noise Reduction*, Leo L. Beranek, McGraw Hill 1960.

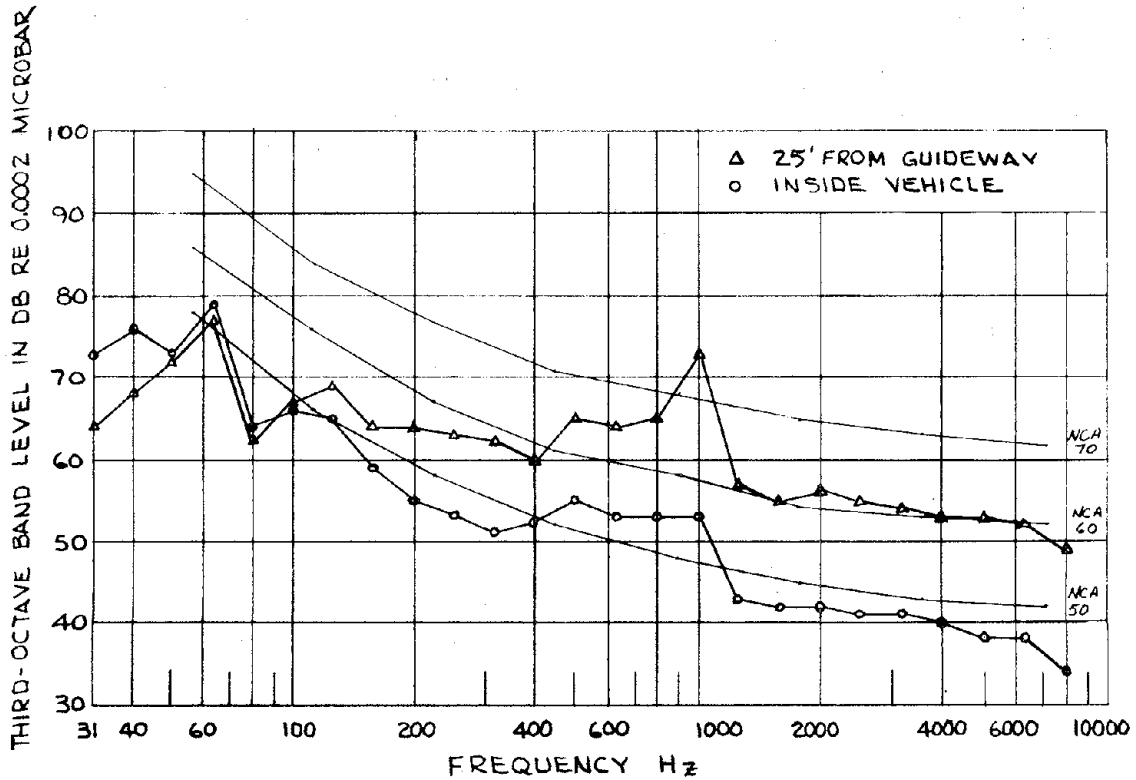

Figure 3-3. Background noise with blower running.

The data gathered in the testing was reduced in 1/3 octave bands with the recording analysis equipment and plotted. Since the background levels were low compared to the noise levels measured, no background correction was necessary.

In addition, an A-weighted sound level (dBA) time history for each of conditions of c and d above at the 25 ft. point and in the vehicle was reduced from the recorded data, using the Bruel and Kjaer high speed level recorder.

Figures 3-4 and 3-5 show the measured sound pressure levels at the 25 ft. point for the conditions specified above. The data shows slightly higher sound pressure levels (2 dB) for the deceleration than the acceleration. The turbine modules are generating more thrust during deceleration, and indicate the noise level is dependent on thrust level.

erent
provide

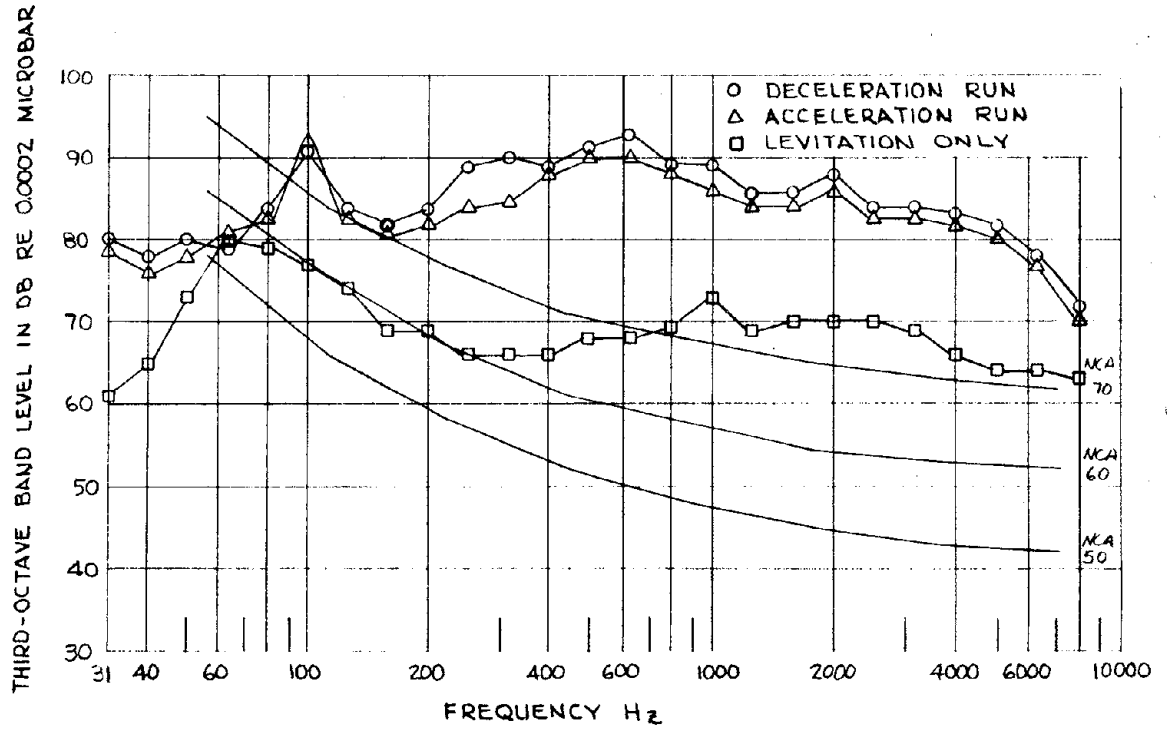

Figure 3-4. Sound Pressure Levels, 25 foot from Guideway, direct measurement, full vehicle.

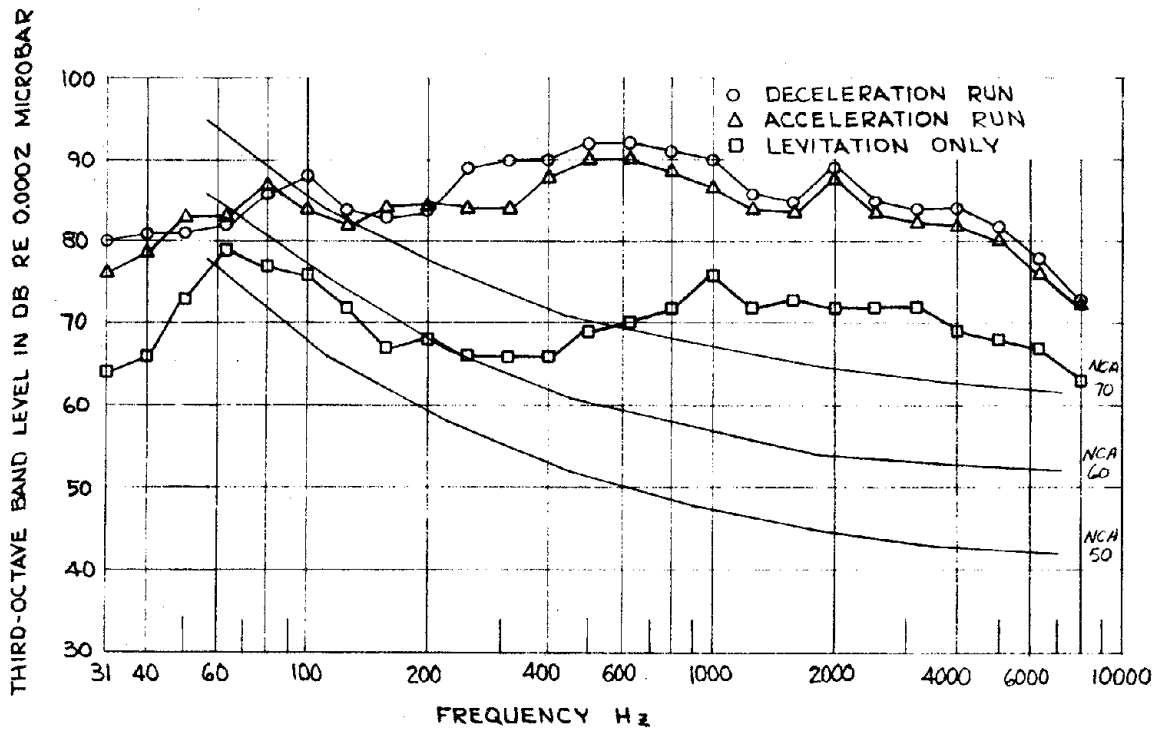

Figure 3-5. Sound pressure levels, 25' from guideway, direct measurement, empty vehicle.

The sound pressure levels during levitation are slightly different for an empty and full vehicle, and are frequency dependent. However, the noise contribution of levitation is small when compared to the acceleration and deceleration values.

To approximate the conditions with a guideway in the out-of-doors, the measurements were corrected for a free field. This data is plotted in Figure 3-6 and 3-7.

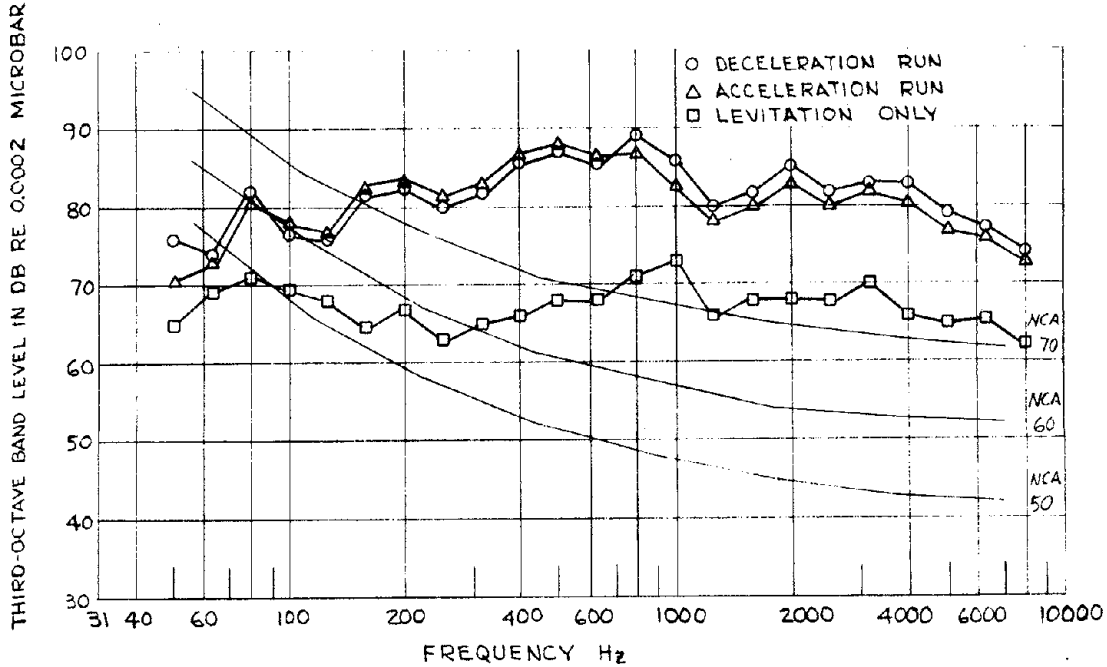

Figure 3-6. Sound pressure levels, 25' from guideway, values corrected for free field, empty vehicle.

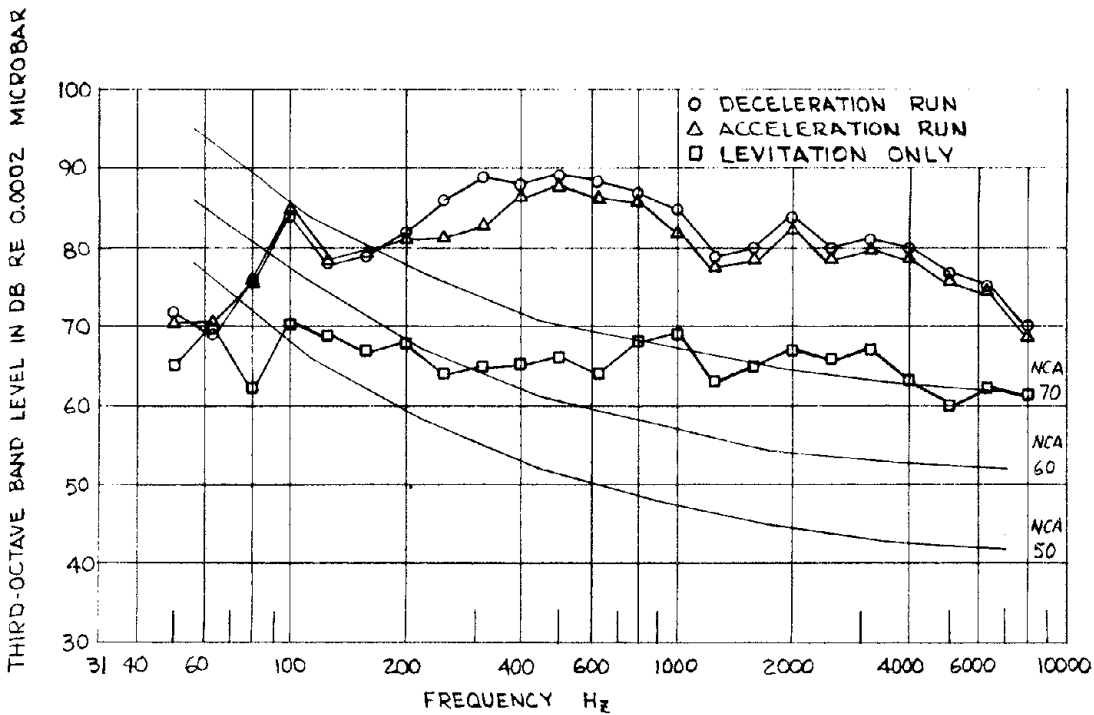

Figure 3-7. Sound pressure levels, 25' from guideway, values corrected for free field, full vehicle.

Figure 3-8 and 3-9 show the sound pressure levels measured inside the vehicle for the conditions specified above. The attenuation of the high frequency sound is very noticeable. The vehicle super-structure was a plywood mock-up without any particular attention to sound reduction. Again, the sound levels for deceleration are higher than for acceleration. The sound levels for a full vehicle with only levitation are about 3 dB higher except at the low frequencies.

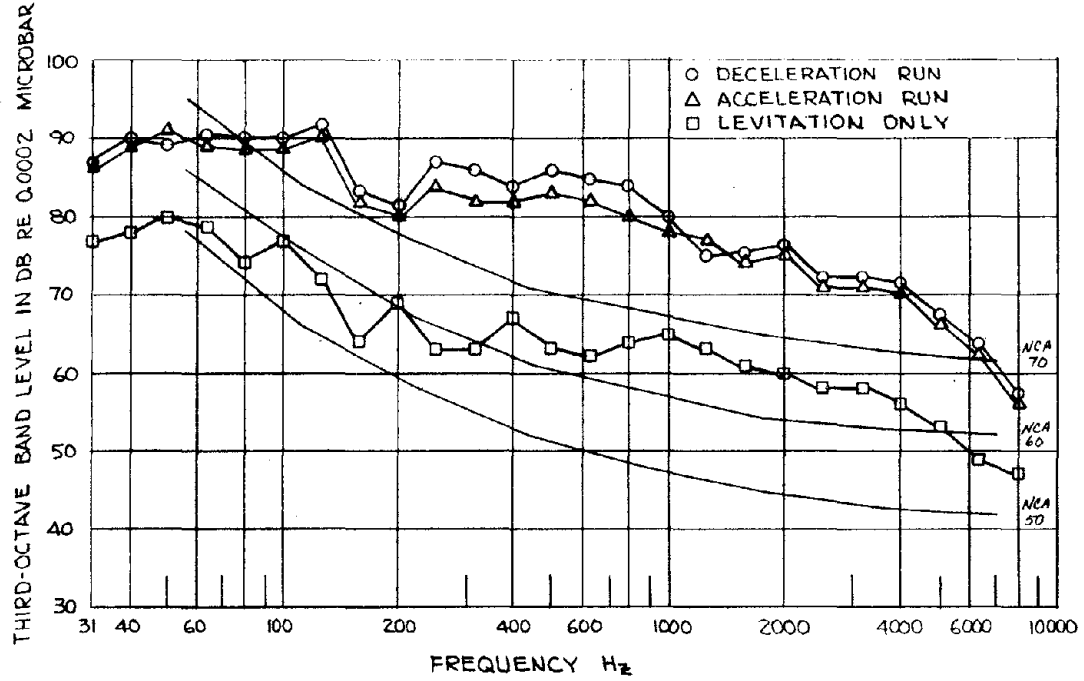

Figure 3-8. Sound pressure levels measured inside empty vehicle.

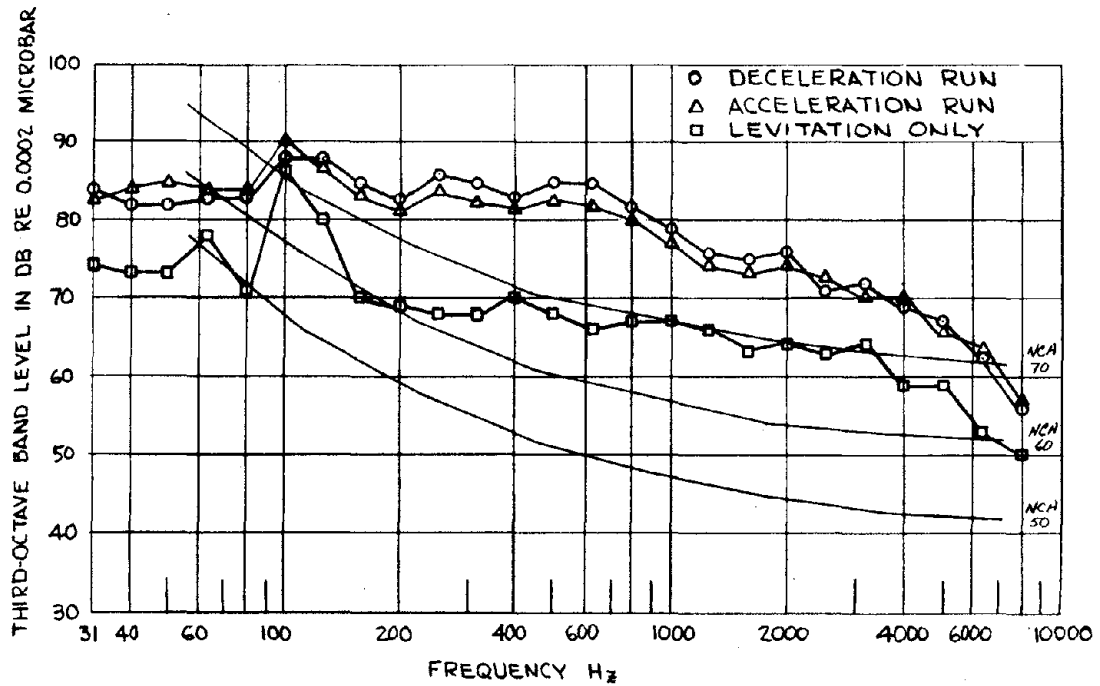

Figure 3-9. Sound pressure levels measured inside full vehicle.

The above tests were made with an acoustical baffling installed over the thrust buckets in the vehicle. (See Section 2.0). The effectiveness of the baffling was poor. The drop at the 25 ft. point was not noticeable on a hand-held dB meter (less than 1 dBA). In the vehicle the attenuation was about 2 dBA.

Figures 3-10 and 3-11 show the A-weighted sound level time history for fully loaded and empty vehicle during acceleration and deceleration, both inside the vehicle and at the 25 ft. point. From the plots the peak values at the 25 ft. point are 102 dBA. Inside the vehicle the levels peak at 94 dBA. The dBA values would be reduced by about 3dB for the free field for the frequency range 315-4000 Hz (see Figure 3-4 through 3-7).

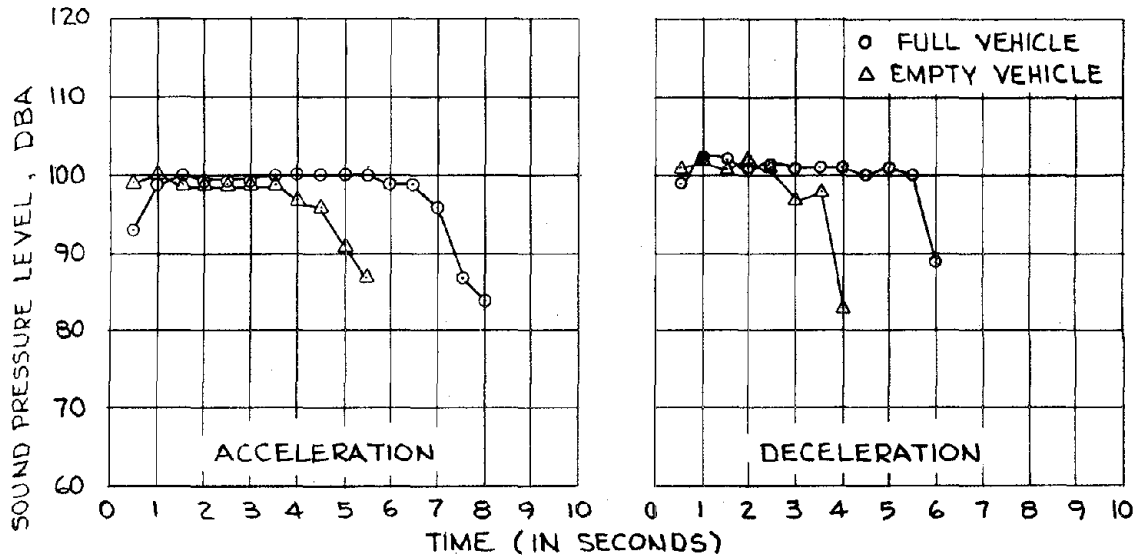

Figure 3-10. Sound pressure levels, DBA, as measured directly, 25' from guideway, versus time.

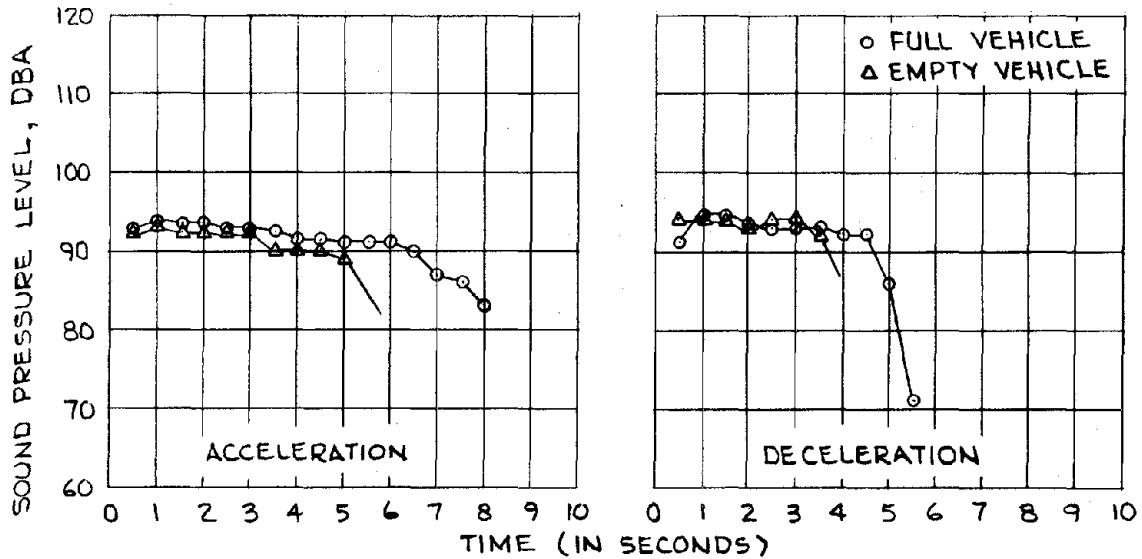

Figure 3-11. Sound pressure levels, DBA, as measured directly, inside vehicle, versus time.

3.4 ENCLOSURE TREATMENT

The structural guideway enclosure is intended to reduce the noise emission, as well as to support the guideway, protect the vehicles and equipment from weather and malicious mischief.

One structural guideway design would be a prestressed concrete U channel with 3 ft. windows and a light concrete roof. This construction is shown in Figure 3-12.

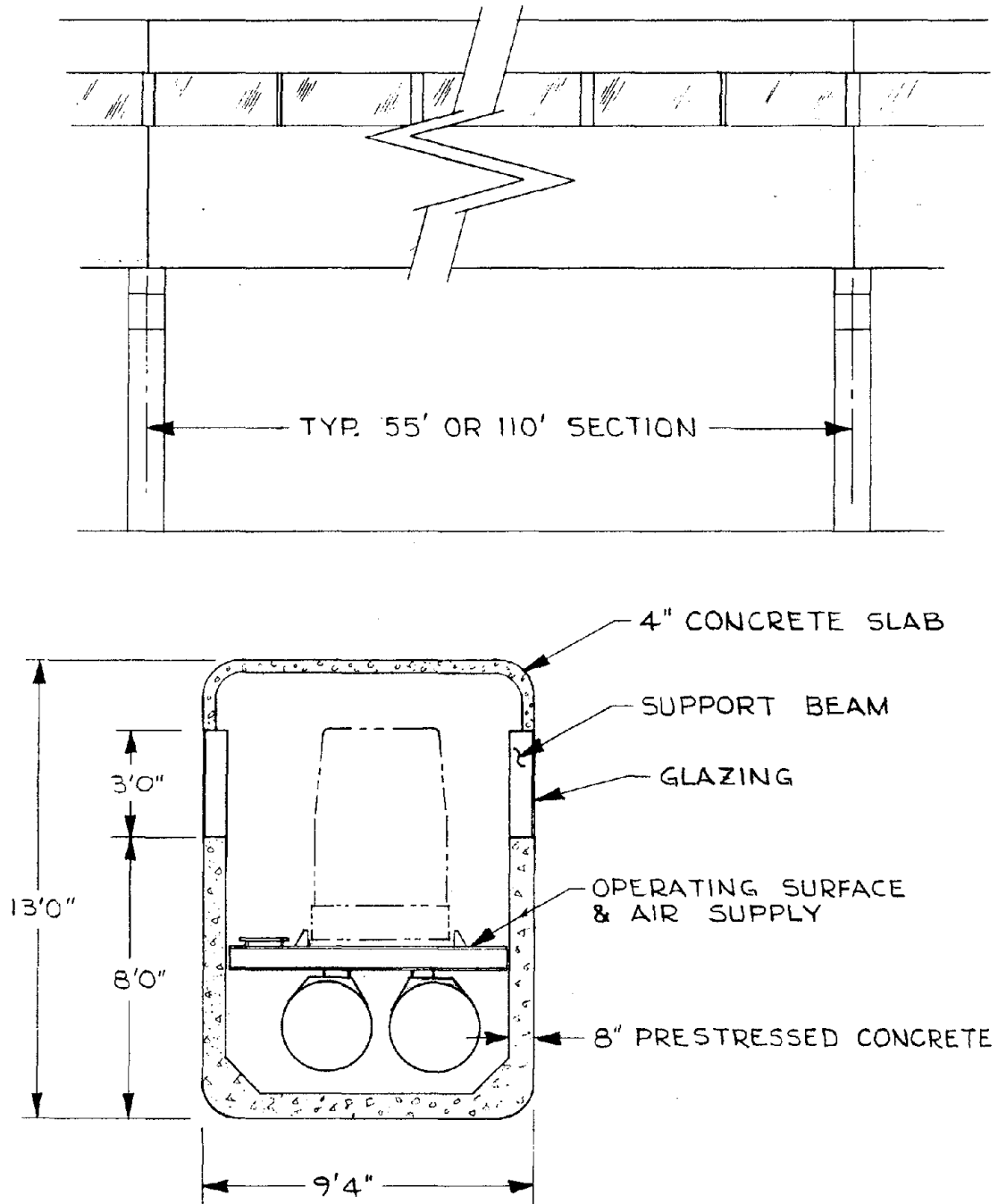

Figure 3-12. Typical structural guideway enclosure.

To reduce the noise at the 25 ft. point to NCA 60, an enclosure with a minimum of 4" prestressed concrete with windows of double glazed Polarpane glass (or their acoustical equivalents) is suggested.

Sound transmission loss (TL) values for 4" concrete (taken from National Bureau of Standards Test No. 804) and for the Polarpane from Polarpane Corporation's trade literature are given as following Table 3-1:

TABLE 3-1
Sound Transmission Loss

Hz	125	172	250	350	500	700	1000	1400	2000	2800	4000	Mean
Concrete	37	33	36	44	45	50	52		60		67	47
Polarpane	25	31	36	40	42	44	45	44	39	36	42	39

(Polarpane is made by C.E. Glass Inc., a subsidiary of Combustion Engineering Inc., 825 Hylten Road, Pennsauken, New Jersey 08110). The Polarpane assembly comprised 1/4" glass separated from 3/16" glass by 51 mm.

The free field SPL values at 25 ft. point expected to result if the specified enclosure were used for the guideway were obtained by reducing the free field values for no enclosure (Figures 3-6 and 3-7) by

$$TL - 8, \text{ dB}$$

where TL is the value from Table 3-1 for the appropriate frequency band and the 8 dB is the amount by which the pressure near the vehicle is expected to be raised by the presence of the enclosure. (See Table IV, page 134 for subways, Report No. OST-ONA-70-2, April 1970, Technical Report: *Evaluating the Noises of Transportation*, and P.W. Wilson (1971), *Rapid Transit Noise and Vibration*, presented at the Rail Transit Conference at ATA, April).

The 8 dB mentioned above could be reduced perhaps by 3 dB by lining the lower part of the interior of the enclosure. See *Rail Vehicle Noise* by T.D. Northwood, Research Paper No. 155 of Div. of Bldg. Resch., Nat. Resch. Council of Canada, Ottawa, 1963.

The sound pressure levels resulting from a treated enclosure are shown in Figures 3-13 and 3-14. As can be seen, the sound pressure levels are well below NCA 60, except for a point at 3000 Hz. This results from the dip in the transmission loss curve for polarpane. For the calculation, the transmission loss for only the polarpane was used. The concrete was equivalent to or greater than the glazing. In the structural guideway the concrete is 8 inches thick, and has an appreciable amount of area. The sound pressure levels could be expected to be slightly lower than those plotted. However, the method of installation of the materials has a pronounced affect on the final values; therefore, the plots are only indicative of final results.

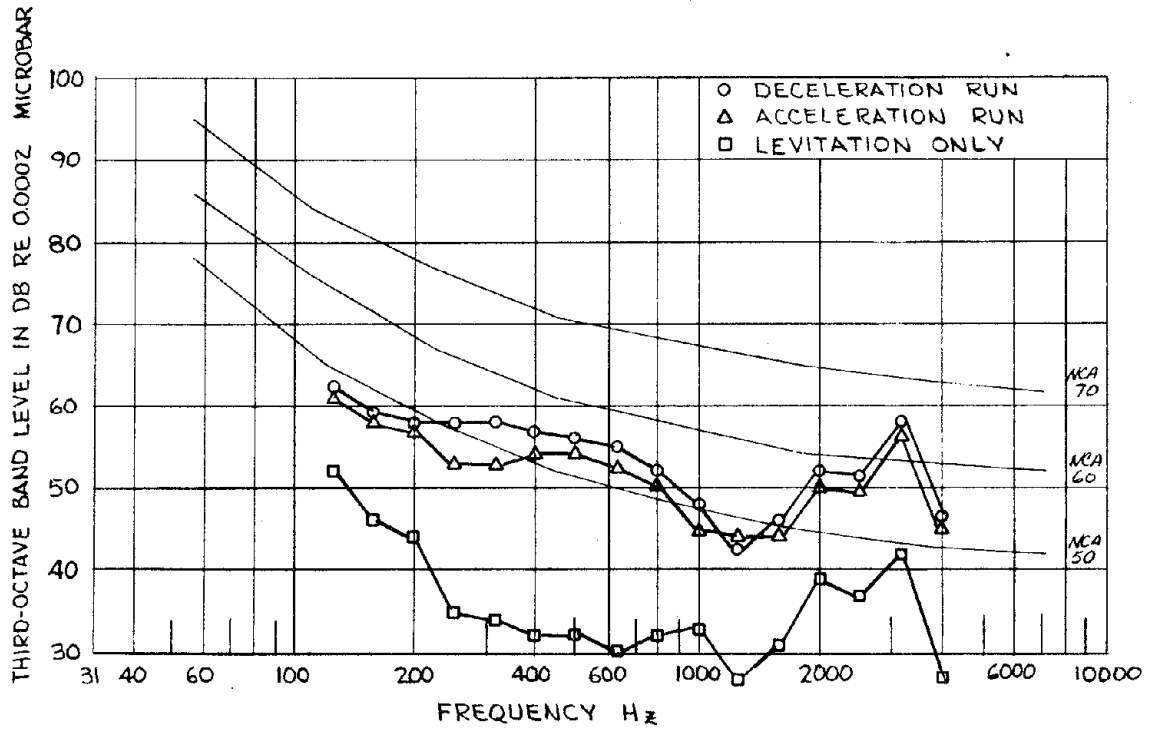

Figure 3-13. Sound pressure levels, 25' from guideway, full vehicle, corrected for free field and recommended enclosure.

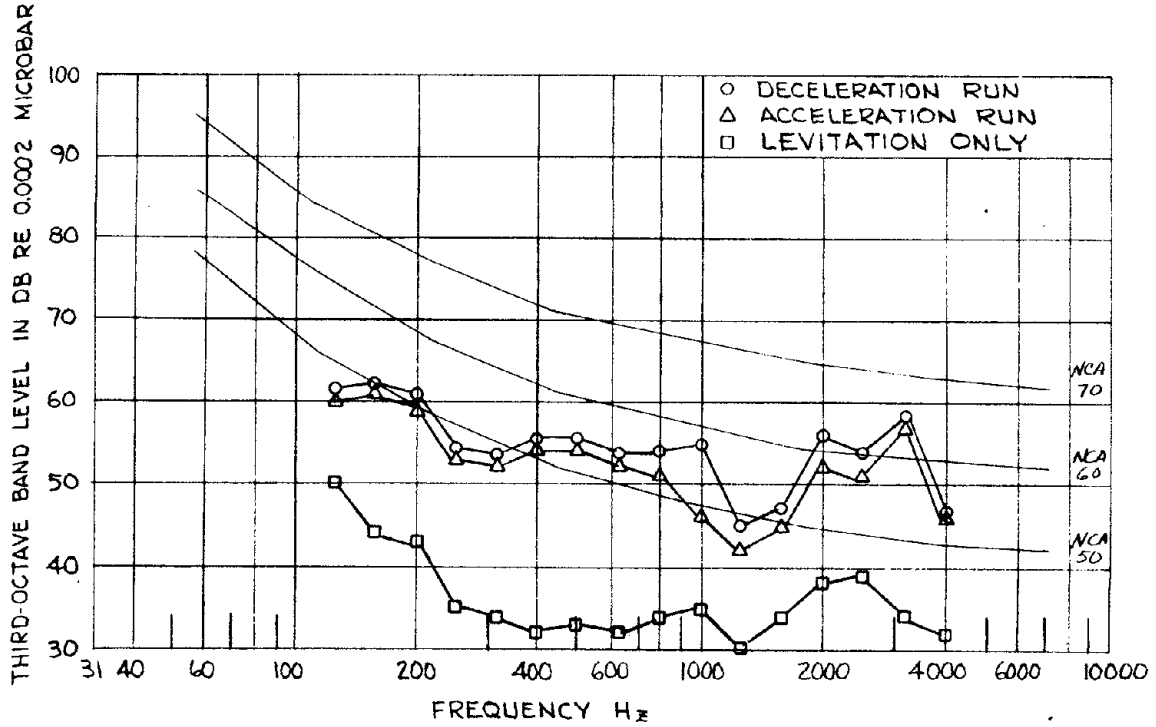

Figure 3-14. Sound pressure levels, 25' from guideway, empty vehicle, corrected for free field and recommended enclosure.

For estimating the dBA values at the 25 ft. point after installation of the enclosure, the pre-enclosure values for dBA are reduced by

$$3 + 42 - 8 = 37 \text{ dB}$$

The 3dB is the average drop off going from the test room to free field found for the frequency range 315-4000 Hz inclusive. The 42 is the average of the TL values for Polarpne over the same frequency range, and the 8 dB is the expected rise near the vehicle due to the enclosure. Figure 3-15 shows the dBA plot versus time for a treated guideway.

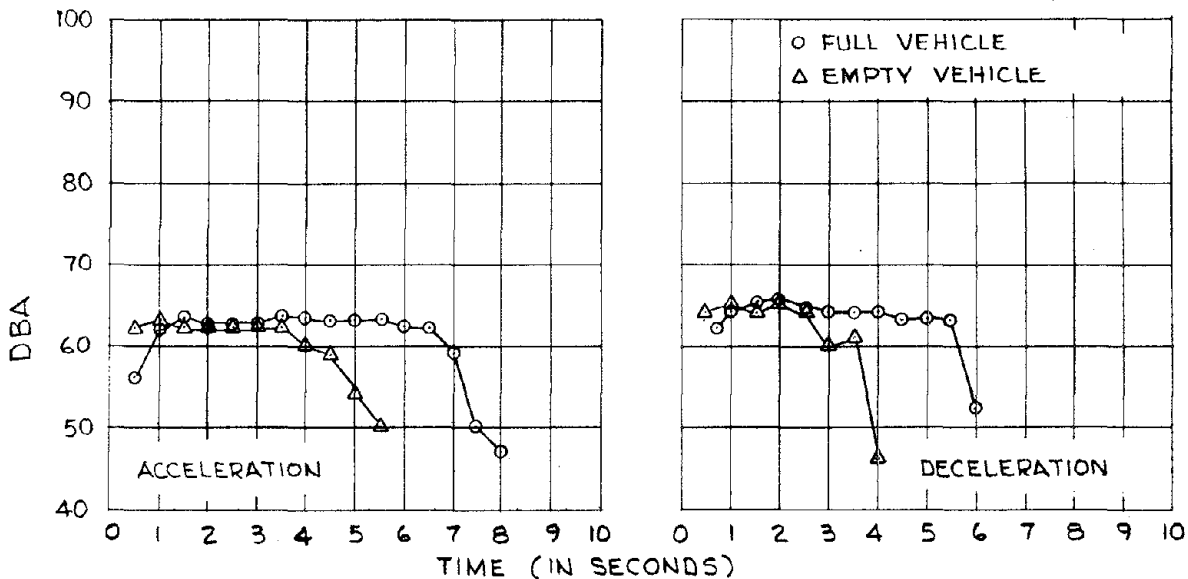

Figure 3-15. Sound pressure levels, dBA, 25' from guideway, corrected for free field and recommended enclosure.

The modifications to the structural enclosure as shown in Figure 3-12 to meet the NCA 60 noise emission criteria would be the addition of double glazing on the windows. All air leaks have to be sealed and any vents provided have to be treated for sound transmission. The cost of adding double glazing in place of single glazing would be \$26.00 per foot, with a 3 ft. high window. If a six foot high window was used, the cost would almost double. The window height is subject to many considerations, and the end user would have strong leverage in determining this factor.

In some cases, there may be no windows, and 4" concrete panels could be used to meet the noise criteria curve.

3.5 ACOUSTICAL TREATMENT FOR THE VEHICLE

The vehicle is presently constructed of 1/4" plywood, 1/8" plexiglass and aluminum framing on a 3/4" plywood floor does not offer adequate noise reduction. Note in Figure 3-11 that interior sound levels may reach 94 dBA in the early deceleration.

It is not known what portion of the sound in the vehicle arrives as structure borne compared to air borne sound.

The noise level SPL in the vehicle resulting from the generation in or entrance into the vehicle of sound equivalent to that from a source of PWL_i operating in the reverberant vehicle will be,

$$SPL = PWL_i - 10 \log A + 6$$

where A is the total absorption of the material in the vehicle.

The noise level in the given vehicle may be approximated with an unknown degree of precision by,

$$SPL = PWL - 3 - TL - 10 \log A + 6$$

where: PWL = sound power level of sound developed outside of the vehicle by its levitation, acceleration or deceleration mechanisms;

- 3 is to indicate that it is assumed half the sound energy impinges on the vehicle surfaces;

TL is the effective transmission loss of the composite window, wall, door and floor of the vehicle; and

A is the absorption in the vehicle.

As an example, take the case of the present vehicle assumed to have been treated acoustically by adding absorption and find the necessary TL of the composite to meet NCA 60.

Since the calculations are rather involved and of uncertain precision, they will be carried out only for a case where maximum correction is needed to show the order of magnitude of the composite TL required.

The case treated is that of the vehicle fully loaded and under deceleration and sound at 500 Hz.

TABLE 3-2

Absorption data for interior of treated car:

Element	Treatment	A, Coeff.	Area, Ft. ²	Abs. Sabins
Floor	Inside outside carpet	0.20	50	10.0
Windows	Glass, double glazed	1.18	76	13.7
Walls & Ceiling	GP-2 Sound Foam 1"	0.62	196	121.5
Chairs	With People Thereon	0.88	23	20.2
TOTAL SABINS				165.4

For 500 Hz, PWL of vehicle = 126 dB, desired SPL = 61 for NCA 60. Thus using the equation previously given;

$$TL = 126 - 3 - 61 - 10 \log 165 + 6 = 46 \text{ dB}$$

Therefore, at 500 Hz the necessary transmission loss of the composite vehicle skin to drop the interior SPL to that for NCA 60 is a transmission loss of 46 dB.

This value of TL is near that given in Table 3-1. To approach these values it is suggested that double glazed Polarpane or its equivalent be used for the windows and that Soundmat LF Light (made by Soundcoat Products, 515 Madison Ave., New York, New York 10022) or its equivalent be applied to a vehicle wall made of 20 gauge steel or heavier as required for structural needs. Data on Soundmat are given in Bulletin 693 by the Soundcoat Co.

With this treatment and on the basis of this calculation, the maximum dBA in the vehicle might be expected to drop to about 70 dBA.

It is further recommended that the floor of the vehicle be made double with a layer of fiberglass sound board in between.

The added cost to make the vehicle meet NCA 60 would be about \$300.00 for the addition of double glazed windows and \$1,200 for the addition of the Soundmat LF Light acoustical material. The total cost per vehicle would be approximately \$1,500.

3.6 CONCLUSIONS AND RECOMMENDATIONS

From the sound pressure measurements, the structural enclosure and the vehicle will require acoustical treatment in order to meet the sound pressure levels specified by NCA 60. The treatment required is technically feasible, and the cost is not excessive. A typical mile of system would increase in cost by \$168,000 (\$138,000 for structural guideway and \$30,000 for 20 vehicles). This appears to be an increase of 3 1/2% in system capital cost.

The prime source of noise generation is the linear air turbine. More work on reducing its noise generation can be more cost effective than reducing the noise transmitted by enclosure materials.

An acoustically treated guideway should be constructed and tested for sound transmission. A vehicle which is acoustically treated should also be constructed and tested.

4.0 HEATING, VENTILATING, AND AIR CONDITIONING STUDY

4.1 ABSTRACT

Several methods of heating, ventilating, and air conditioning Uniflo vehicles using air from the levitation pad system were examined and compared. The preferred system is comprised of a passive vehicle mounted heat exchanger (HS Unit) that operates as a heat sink or heat source to condition the vehicle ventilating air flow bled from the vehicle levitation pad system. The HS Unit is recharged (heated or cooled) during the dwell time in the stations while the vehicle is being off-loaded and reloaded by forcing air (which has been heated or cooled as required by station based equipment) through the HS Unit. This system is fundamentally efficient in that only the vehicle interior volume and the air actually used to ventilate this space is conditioned.

The vehicle mounted HS Unit has an estimated capital cost of \$1,400. The station based heating and refrigeration system that regenerates the HS Unit, during the vehicle dwell time in the station, has an estimated capital cost of \$6,700/berth. This is based on a charge rate factor of 5 that enables the vehicle to operate continuously for 2 hours when the trip time is 8 times the station dwell time. The estimated capital cost of a direct-fired burner plumbed into the regeneration system that will recharge the HS Unit when it is used as a heater during the heating season is \$500/berth.

The operating cost of the air conditioning equipment per berth with a charge rate factor of 5 at peak load is estimated to be \$.11 per hour, while the operating cost of the heating equipment per berth at peak load is \$.08 per hour.

4.2 BACKGROUND

Personal rapid transit systems are characterized by many relatively small vehicles operating in series at close headways on exclusive guideways. In any transit system employing exclusive guideways, a vehicle breakdown that results in a stalled vehicle effectively stops all traffic on the line in question. It is, therefore, imperative that vehicle reliability in a personal rapid transit system be maximized if high system reliability is to be achieved. The original Uniflo Personal Rapid Transit System concept was based upon completely passive vehicles (no on-board propulsion system, no on-board controls, no on-board lights, no on-board powered heating, ventilating, air conditioning system). Throughout the development of the Uniflo Personal Rapid Transit System, the objective of a completely passive vehicle has been a continuing design goal, and has strongly influenced the approach to vehicle heating, ventilating, and air conditioning.

The objective of this study is to determine the optimum approach to Uniflo vehicle heating, ventilating and air conditioning, keeping the system passive so far as the vehicle is concerned.

Study Conditions – Two reference ambient conditions were defined, one for cooling and one for heating:

Cooling	Dry Bulb Temperature	96°F
	Wet Bulb Temperature	80°F
	Relative Humidity	50%
	Wind	15 mph
Heating	Dry Bulb Temperature	0°F
	Wet Bulb Temperature	-1°F
	Relative Humidity	50%
	Wind	0 mph

Consideration was given to several other variables as follows:

Wind – The 15 mph wind velocity was used to determine film coefficients for overall heat transfer coefficients in calculations related to guideway heat dissipation or absorption under cooling conditions.

Under heating conditions it was concluded that wind could be ignored, since calculations showed that guideway air temperature would, for all practical purposes, be equal to the ambient temperature for all wind conditions, and it is the guideway air temperature that determines vehicle heating load.

Solar Load – Solar heating was taken into account for cooling calculations. Guideway alignment was assumed to be East/West to produce maximum solar heat input to the system.

Under heating conditions it was assumed that there was no solar heating since such an assumption results in maximum heating requirements. (See Appendix B for further discussion of Solar Heat Load).

System Configuration – The system configuration and system operating conditions that were assumed for this HVAC study are as follows:

Guideway – A one-way elevated structure as shown on Figure 4-1, one-half mile in length, serviced at midpoint by a blower station.

Number of Vehicles - 7

Vehicle Description – Length 16', Width 46", Height - 70", Volume 300 cu. feet,
Capacity 8, 10 or 12 passengers. Surface area, 321 square feet.

Total Air Flow – 12.7 lb./sec.

Temperature Rise Thru Blower – 35° (Blower Efficiency 60%)

Vehicle Air Conditioning Requirements – The interior of the Uniflo vehicle should be conditioned to:

Summer:

Ventilating Air Flow – 120 SCFM
Temperature, dry bulb – 80°F (max.)
Temperature, wet bulb – 70°F (max.)

Winter:

Ventilating Air Flow – 120 SCFM
Temperature, dry bulb – 50° (min.)
Temperature, wet bulb – 44° (max.)

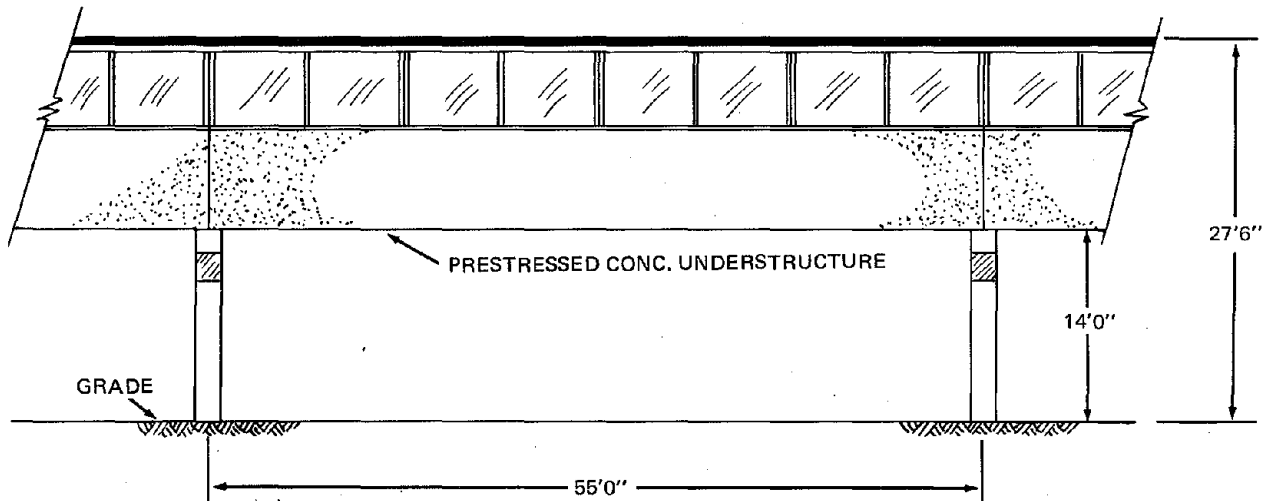

ELEVATION
TYPICAL 55'0 SPAN

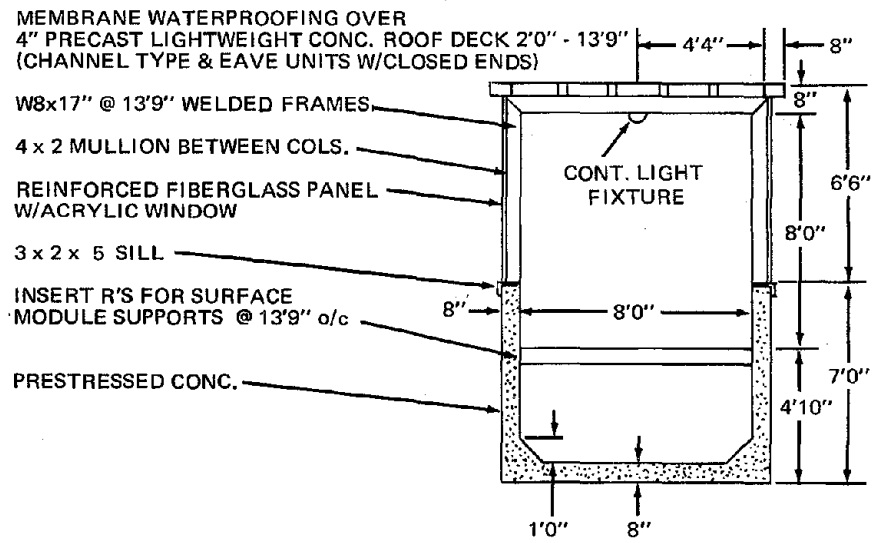

TYPICAL CROSS SECTION

Figure 4-1. One Way Elevated Structure

4.3 VEHICLE AIR CONDITIONING BY BLOWER STATION BASED AIR CONDITIONER

Initially consideration was given to heating or cooling the Uniflo PRT by ventilating the vehicle with conditioned air drawn from the levitation pad system under the vehicle. This approach to HVAC requires that the air be cooled (or heated) at the blower station so that, on the average, the ventilating air flow through the vehicle would maintain the vehicle atmosphere at the desired 80° DBT, 70° WBT under air conditioning conditions, and at 50° DBT under heating conditions when ambient temperatures are in the zero degree range.

If the guideway structures are *perfectly insulated*, and the circulation system (Figure 4-2) is designed to recycle 90% of the air, with a dehumidification coil processing the 10% fresh air for humidity control, and a cooling coil to cool the air from the blower to the desired 80° DBT, the combined cooling system would have to have the capacity of 37.6 tons per half mile.

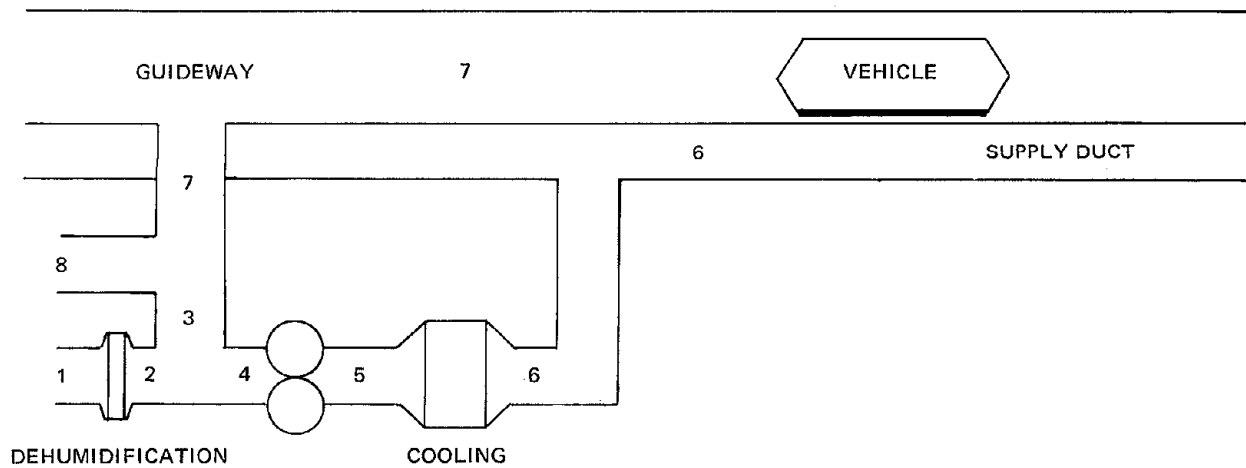

LOCATION	TEMP. °F		PERCENTAGE OF TOTAL AIR FLOW	PER HALF MILE	
	DB	WB		DEHUMIDIFICATION	COOLING
1 Inlet Air	96	80	10	4.8 tons	
2 Conditioned Inlet Air	66	66	10		32.8 tons
3 Recycled Air	80	70	90		
4 Blower Inlet Air	79	69	100		
5 Blower Outlet Air	114	79	100		
6 Supply Air	80	70	100		
7 Guideway Air	80	70	100		
8 Exhaust Air	80	70	10		
				TOTAL AIR COND. LOAD	37.6 tons

(TOTAL AIR FLOW = 12.7 LB./SEC.)

Figure 4-2. Blower Station Based Cooling with *Perfectly Insulated* Guideway Structure (condition 100% of supply air).

Since the Uniflo guideway has two parallel supply ducts, the question is raised, "Would this cooling load be reduced if the air in only one duct, i.e., half the blower discharge air, is cooled and used to ventilate the vehicle?" Again assume a *perfectly insulated* guideway structure. Figure 4-3 is a schematic of this circulation system. The ventilation air, 2 SCFM, is taken from the levitation pads, that are supplied by air from the cooled supply duct. The guideway air temperature is now greater than the 80°DB, as it is the average of the 50% of the blower discharge that is cooled and the 50% that is not cooled. Because the vehicle is operating in guideway air that is warmer than the vehicle interior (80° DB), it picks up heat from the guideway air. The 2 SCFM of ventilating air flow must be cooled below the desired 80° DB temperature to compensate for this heat load and the passenger heat load. With a well insulated vehicle, the vehicle cooling load could be accommodated with 66° DB ventilating air temperature. Such a system requires 35.4 tons of cooling. Note that this does not represent a significant reduction in cooling load compared to the system where 100% of the supply air is conditioned.

If an actual guideway structure such as that shown in Figure 4-1 is hypothesized and thermal losses and solar loads for the reference hot day are taken into account, the air conditioning load is 125.9 tons

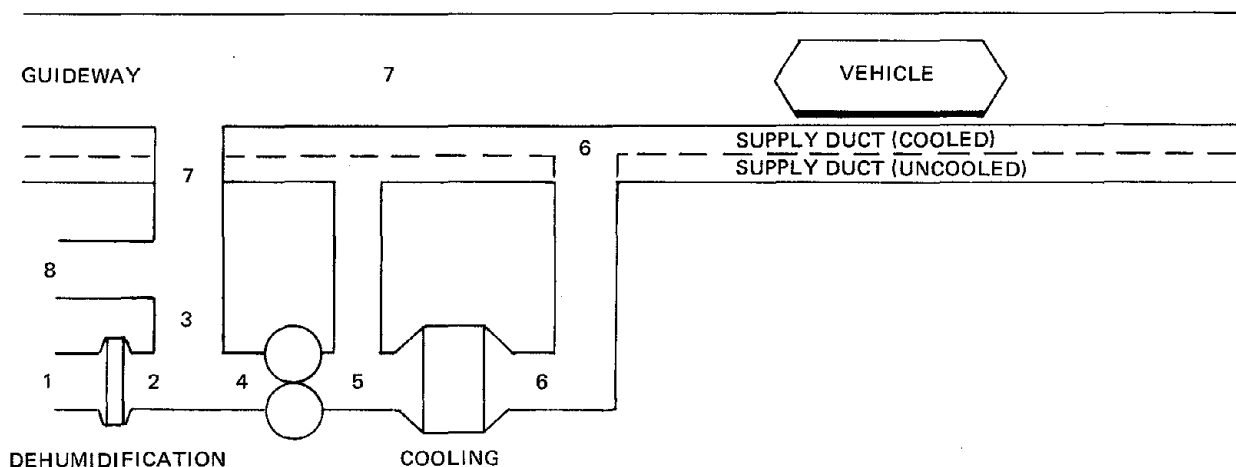

LOCATION	TEMP. °F		PERCENTAGE OF TOTAL AIR FLOW	PER HALF MILE	
	DB	WB		DEHUMIDIFICATION	COOLING
1 Inlet	96	80	10	4.8 tons	
2 Conditioned Inlet	66	66	10		30.6 tons
3 Recycled	98	75	90		
4 Blower Inlet	95	74	100		
5 Blower Outlet	130	83	100		
6 Conditioned Supply	66	66	50		
7 Guideway	98	75	100		
8 Exhaust	98	75	10		
				TOTAL AIR COND. LOAD	35.4 tons

(TOTAL AIR FLOW = 12.7 LB. /SEC.)

Figure 4-3. Blower Station Based Cooling with *Perfectly Insulated* Guideway Structure (condition 50% of supply air).

per half mile (Figure 4-4). Assuming optimistically that half the required cooling load could be accomplished with water coils and half with a mechanical refrigeration system, the estimated capital cost of the cooling system would be: 63 ton water chiller coil system \$5,000.00 and 63 ton mechanical refrigeration system – 63 x \$650/ton = \$41,000 for a total cost of \$46,000. The system has 7 vehicles per half mile, so the cost per vehicle is \$6,600.

For any of the preceding cases the heat and moisture introduced to the system by the passengers is such a small percentage of the total cooling load that this factor can be neglected.

Comparing the energy requirements for cooling with a perfectly insulated guideway system with a real system shows that improving guideway insulation reduces the size of the cooling system. However, even if a perfectly insulated guideway were achieved, the energy requirements remain high because the cooling system must remove all of the thermal energy introduced by the blowers to the working fluid.

Uniflo vehicles in transit can be cooled or heated by conditioned air delivered to the vehicle via the levitation pad system. However, none of the circulation systems evaluated appear to be efficient solutions to the vehicle air conditioning problem. The actual vehicle air conditioning load is only 0.45 tons per vehicle, while the best of these station based systems require 5 tons of refrigeration capacity for each vehicle in transit. The possibility exists that a more efficient circulation system for delivering the blower station conditioned air to the vehicle may be developed. If such a system can be realized, the highly desirable objective of vehicles that contain no vehicle borne air conditioning equipment would be met.

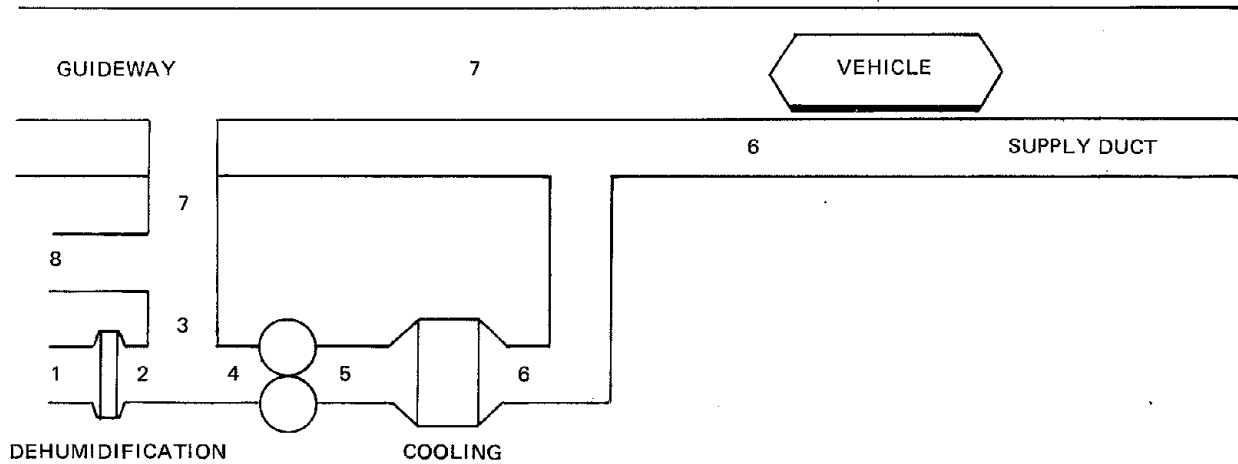

LOCATION	TEMP. °F		PERCENTAGE OF TOTAL AIR FLOW	PER HALF MILE	
	DB	WB			
1 Inlet	96	80	10	DEHUMIDIFICATION	10.9 tons
2 Conditioned Inlet	40	40	10	COOLING	115.0 tons
3 Recycled	125	72	90	TOTAL AIR COND.	125.9 tons
4 Blower Inlet	117	71	100		
5 Blower Outlet	152	79	100		
6 Conditioned Supply	40	40	100		
7 Guideway	125	72	100		
8 Exhaust	125	72	10		

(TOTAL AIR FLOW = 12.7 LB. /SEC.)

NOTE: Guideway structure similar to Fig. 4-1 except supply ducts assumed to be perfectly insulated.

Figure 4-4. Blower Station Based Cooling with a Realistic Guideway Structure and Solar Load (condition 100% of supply air).

4.4 VEHICLE AIR CONDITIONING BY VEHICLE BORNE HEAT SINK

Air conditioning Uniflo vehicles by conditioning all of the air (the system working fluid) as it goes through the blower stations so that some of the air can be drawn off the vehicle levitation pad system to ventilate and cool the vehicle interior, as indicated in the previous section of this report, is an inefficient approach to vehicle air conditioning. A fundamentally more efficient approach to vehicle air conditioning employs a heat-sink heat exchanger (referred to hereafter as the HS unit) mounted on the vehicle. The objective of a passive vehicle is met by designing the HS unit so that it can be recharged, i.e., remove or add heat to create a usable heat-sink or heat source, by passing refrigerated or heated air from a station based refrigeration or heating system through the HS unit during the time that the vehicle is in its berth. While the vehicle is in transit, air bled from the pad system passes through the HS unit, which cools and dehumidifies or heats the air, and is then used to ventilate the vehicle. The vehicle ventilating system based on the HS unit is shown in Figures 4-5, 4-6, and 4-7. (Appendix B contains information pertaining to vehicle ventilation, the HS Unit, and the station equipment for recharging the HS Unit).

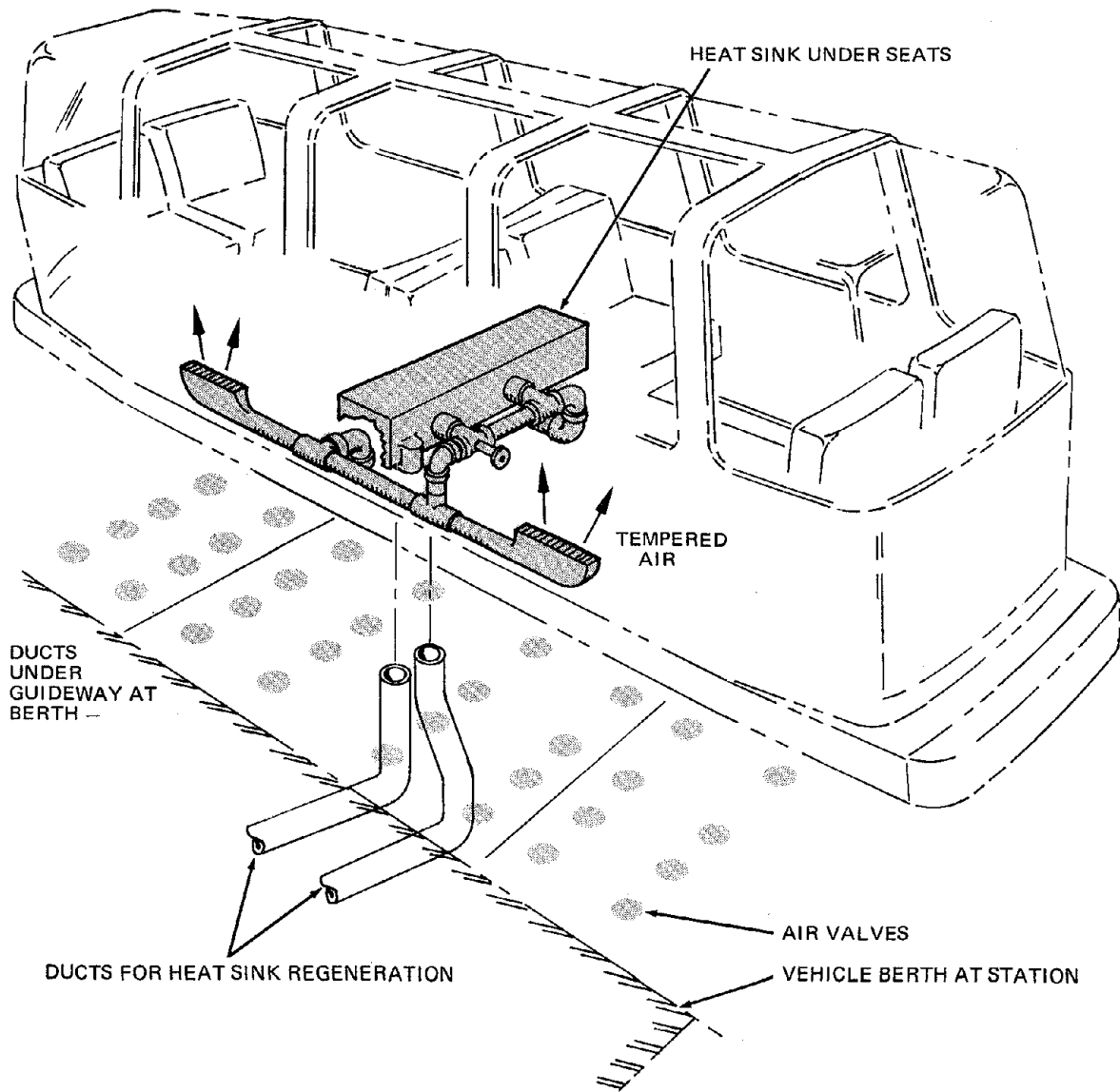

Figure 4-5. Heat Sink Unit - Vehicle Installation Diagram.

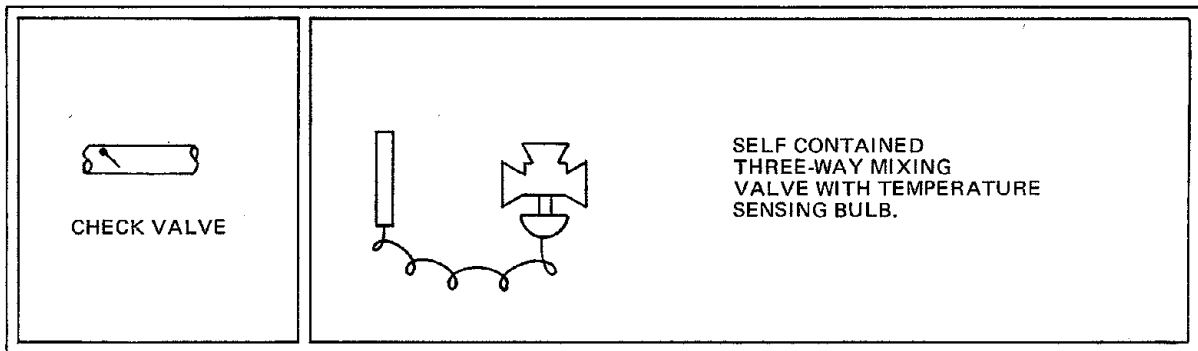
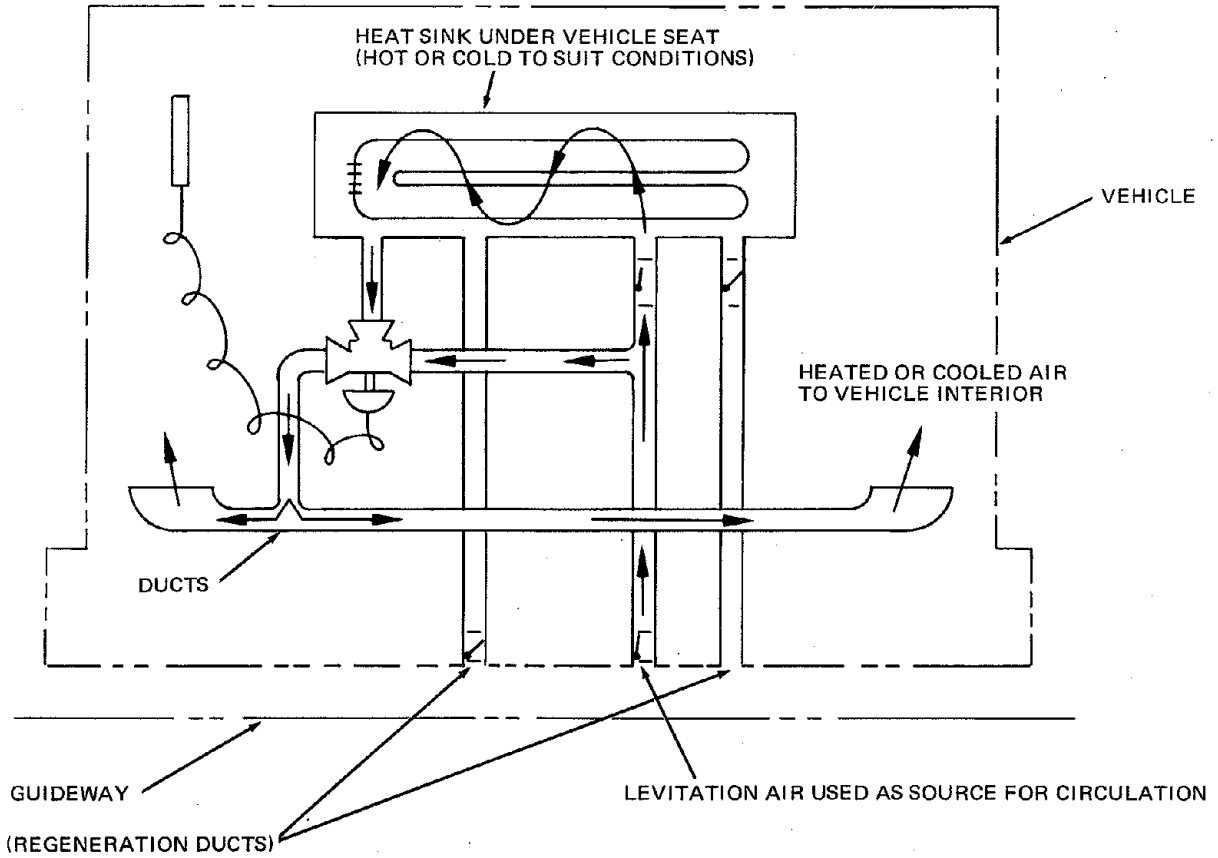

Figure 4-6. Heat Sink Unit – Circulation System for Vehicle Heating and Cooling.

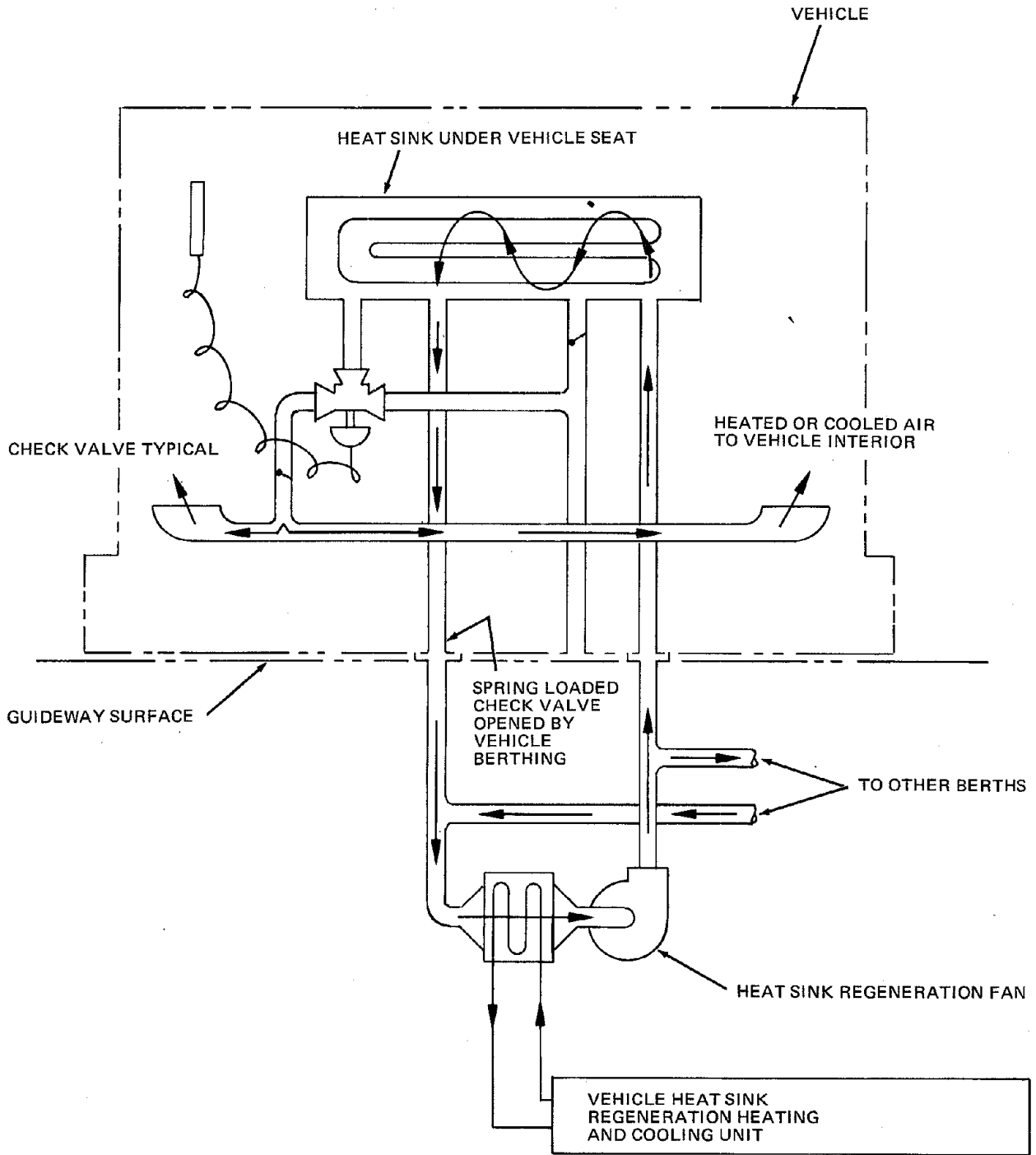
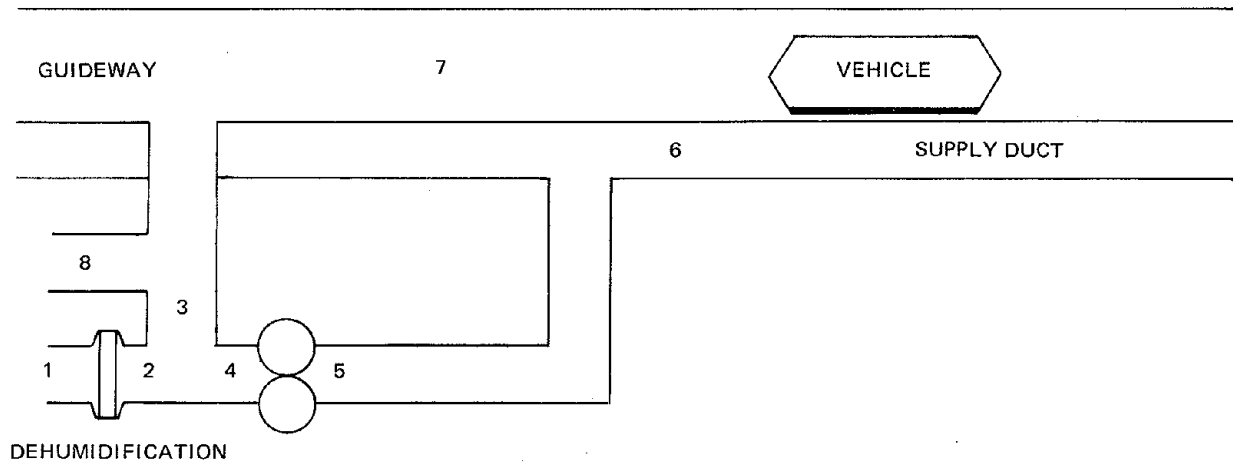

Figure 4-7. Heat Sink Unit – Berth and Vehicle Circulation System for Regeneration.

Using the vehicle based HS unit, four alternative air circulation systems as far as the guideway and blower station system is concerned, are possible:

Alternate 1. Ninety percent (90%) of the air from the guideway is returned to the blower inlet where it is mixed with 10% fresh air, which has been dehumidified for ventilation purposes.



LOCATION	NO SOLAR LOAD TEMP °F		SOLAR LOAD TEMP °F		PERCENTAGE OF TOTAL AIR FLOW
	DB	WB	DB	WB	
1 Inlet	96	80	96	80	10
2 Conditioned Inlet	66	66	66	66	10
3 Recycled	110	78	139	85	90
4 Blower Inlet	106	77	132	83	100
5 Blower Outlet	137	85	167	90	100
6 Supply (avg.)	106	77	135	84	100
7 Guideway (avg.)	100	75	129	82	100
8 Exhaust	110	78	139	85	10

Dehumidification Load = 4.9 tons/half mile

Max. Vehicle Cooling Load = 1.95 tons/vehicle

Figure 4-8. Vehicle Borne Heat Sink Unit Alt. 1. Recycle 90% of air with Blower Station Dehumidification of Fresh Air.

Alternate 2. The blower inlet air is 100% fresh air cooled (to dehumidify it) by a heat exchanger at the blower inlet, and the tunnel is ventilated by natural draft effect.

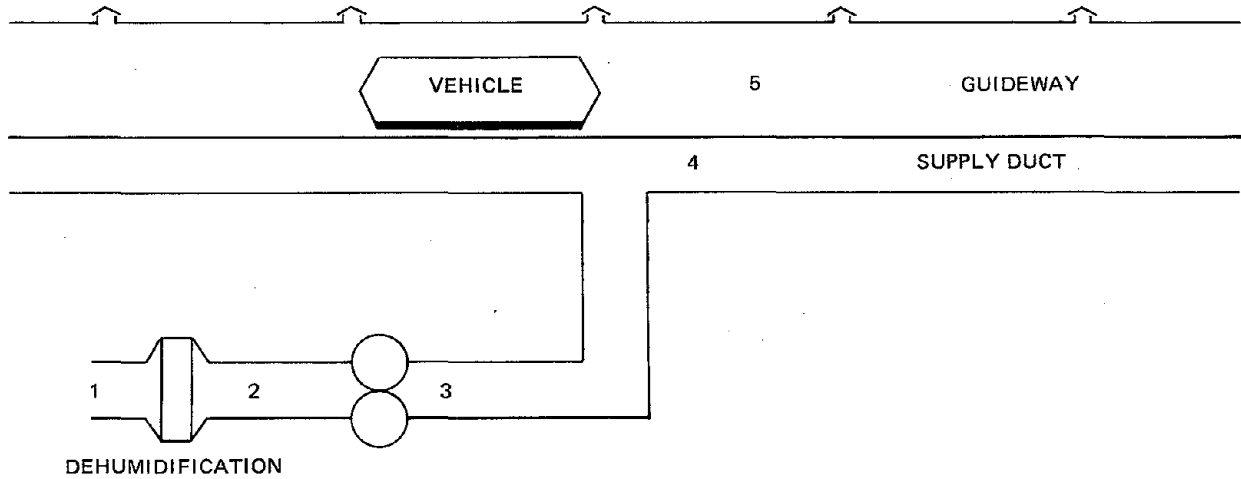

LOCATION	NO SOLAR LOAD TEMP °F		SOLAR LOAD TEMP °F		PERCENTAGE OF TOTAL AIR FLOW
	DB	WB	DB	WB	
1 Inlet	96	80	96	80	100
2 Cond. Blower Inlet	66	66	66	66	100
3 Blower Outlet	101	76	101	76	100
4 Supply (avg.)	98	75	108	78	100
5 Guideway (avg.)	97	—	110	—	100

Dehumidification Load = 49 tons / half mile
 Max. Vehicle Cooling Load = 1.2 tons / vehicle

Figure 4-9. Vehicle Borne Heat Sink Unit Alt. 2. No recycling, guideway ventilated, and Blower Station Dehumidification of 100% of Inlet air.

Alternate 3. The blower inlet air is 100% fresh air, the blower discharge is cooled to ambient temperature, and the tunnel is ventilated by natural draft effect.

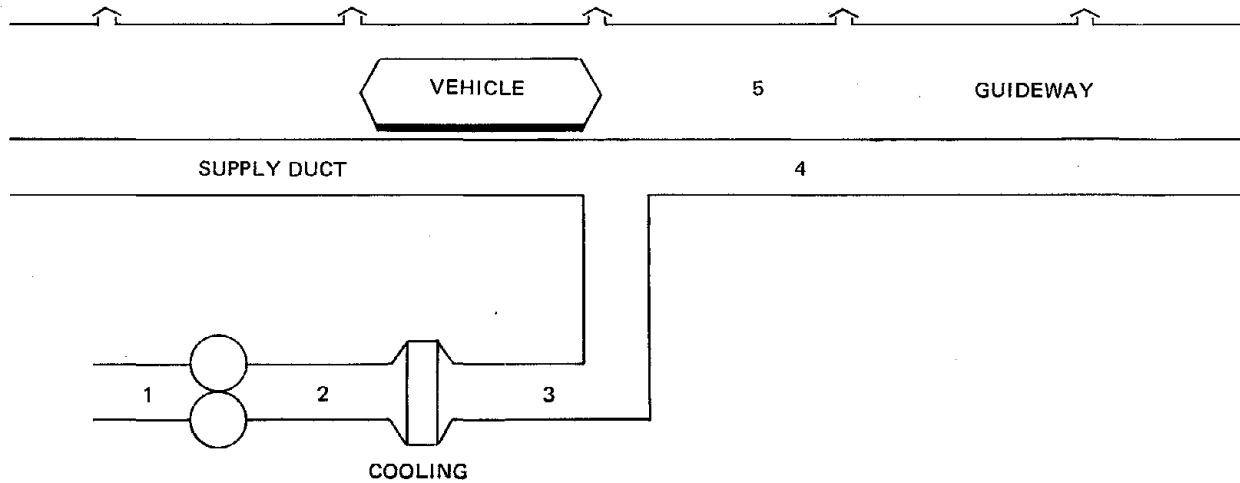

LOCATION	NO SOLAR LOAD TEMP °F		SOLAR LOAD TEMP °F		PERCENTAGE OF TOTAL AIR FLOW
	DB	WB	DB	WB	
1 Inlet	96	80	96	80	100
2 Blower Outlet	131	88	131	88	100
3 Cond. Supply	96	80	96	80	100
4 Supply (avg.)	96	80	107	83	100
5 Guideway (avg.)	96	80	110	83	100

Blower Discharge Cooling Load = 35.4 tons/half mile
 Max. Vehicle Cooling Load = 1.4 tons/vehicle

Figure 4-10. Vehicle Borne Heat Sink Unit Alt. 3. No recycling, blower outlet cooled to ambient conditions.

Alternate 4. The blower inlet air is 100% fresh air with no thermal processing of the air at the blower stations, and the tunnel is ventilated by natural draft effect.

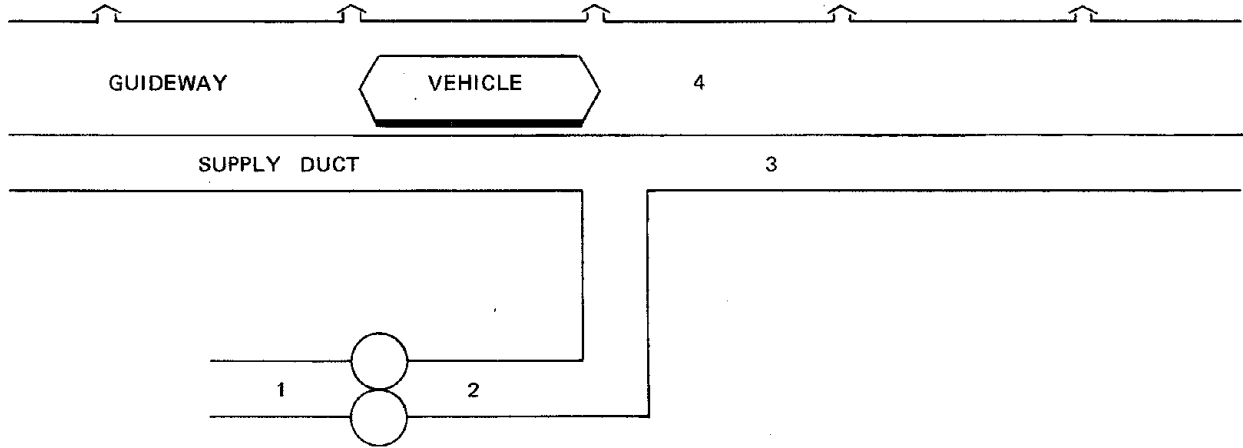

LOCATION	NO SOLAR LOAD TEMP. °F		SOLAR LOAD TEMP. °F		PERCENTAGE OF TOTAL AIR FLOW
	DB	WB	DB	WB	
1 Inlet	96	80	96	80	100
2 Blower Outlet	131	88	131	88	100
3 Supply (avg.)	104	82	115	84	100
4 Guideway (avg.)	99	81	110	83	100

Max. Vehicle Cooling Load = 1,5 tons/vehicle

Figure 4-11. Vehicle Borne Heat Sink Unit Alt. 4. No recycling, no cooling of air at the Blower Station.

Alternate 1 can be dismissed as being impractical because supply duct and vehicle passageway average temperature levels rise to 20° to 40° above ambient to dissipate the solar heat input and the thermal input of the blower to the working fluid. This significantly increases the heat transfer into a vehicle in transit. It also increases the amount of heat to be removed from the vehicle ventilating air by approximately 30%. The net result is an excessively high vehicle cooling load.

Alternate 2 incorporates a ventilated guideway structure which precludes recycling of the air, the working fluid. Ventilating the guideway by natural or forced draft is an effective and efficient method of dissipating the solar heat load and the heat introduced into the working fluid by the blower. All of the air is dehumidified prior to the blower inlet by cooling the air to 66° WBT. This requires 49 tons of refrigeration per half mile. The air from the blower will enter the supply duct system at 101° DBT, 76° WBT. Since the supply duct system is not well insulated, and the ventilated vehicle passageway is at 110° DBT, the average supply duct temperature, which is also the average temperature of the ventilating air entering the vehicle HS unit, will be about 108° DBT. Because the ventilating air arriving at the vehicle is dehumidified, the required load on the HS unit is only 1.2 tons.

Alternate 3 is the same as Alternate 2, except that instead of dehumidifying the inlet air, a heat exchanger is added at the blower outlet. This heat exchanger is designed to reduce the blower outlet temperature (without dehumidification) from 131° DBT to 96° DBT (ambient). Thus the air enters the supply duct at ambient temperature level, and on a zero radiation day would neither pick up nor reject any significant amount of heat in its passage through the supply duct to the point of usage. On days when the solar load is maximum, the natural draft or forced draft ventilation of the vehicle passageway in the guideway, minimizes the importance of thermal insulation of the guideway and/or the supply duct system. As a result, the system is relatively insensitive to solar loads. Because the cooling downstream of the blower does not involve dehumidification, it requires only 35.4 tons of cooling, compared to 49 tons in Alternate 2, where dehumidification of all the working fluid was achieved.

The vehicle HS unit must dehumidify the ventilating air; consequently, with Alternate 3, the vehicle cooling load is 1.42 tons, slightly more than the 1.2 tons required with Alternate 2, where the ventilating air arrives at the vehicle dehumidified.

Alternate 4 circulation system, like Alternates 2 and 3, is based on no recirculation of the working fluid which permits guideway ventilation by natural or forced draft, making it practical to limit guideway air temperatures to 110° on a reference hot day with a full solar load. Thus, where average passageway temperatures would range up to 135° F under solar load conditions with Alternate 1 on a 96° DBT 80° WBT day, this temperature would not exceed 110° F with a ventilated guideway. Because the air supply ducts are not insulated, the average temperature of the air delivered to the vehicle tends to approach guideway air temperature, resulting in an HS unit load requirement of 1.5 tons with no other air processing equipment.

4.5 CONCLUSIONS

Table 4-1 presents in tabular form the results of the analysis of the four alternate system approaches to Uniflo vehicle cooling. These results indicate the solar load can best be handled by ventilating the guideway. This ventilation can be accomplished by natural draft, although mechanical ventilation may be employed and may be desirable when acoustic requirements are factored into the solution. These results also show that the most efficient approach to vehicle air conditioning is Alternate 4, which places all the burden directly on the vehicle born HS unit.

Estimated costs of the four alternate systems are also shown on Table 4-1. Alternate 4 is the lowest capital cost system.

Any alternate that involves processing the working fluid, even 10% of it, on a continuous basis results in very large capacity cooling/refrigeration systems.

Alternate Number	Blower Inlet Air	Guideway	Blower Disch. Air	Supply Duct Average Temp.		Vehicle Passageway Average Temp.		Energy Requirements		Total Tons per Vehicle	Estimated Cost	
				No Solar Load	With Solar Load	No Solar Load	With Solar Load	Blower Station Processing Per Mile	Vehicle Cooling		Expressed as Capital Cost per Mile	Expressed as Capital Cost per Vehicle
1	90% recycled 10% dehumid. to 66°WB	Sealed to permit recycling	Not processed	106°DB 77°WB	135°DB 84°WB	100°DB 75°WB	129°DB 82°WB	9.8 tons	1.9 tons/vehicle	2.6	\$30,160	\$2,150
2	100% fresh dehumidified to 66°WB	Natural Draft Ventilated	Not processed	98°DB 75°WB	108°DB 78°WB	97°DB	110°DB	9.8 tons	1.2 tons/vehicle	8.2	\$47,600	\$3,400
3	100% fresh	Natural Draft Ventilated	Cooled to Inlet Ambient Cond.	96°DB 80°WB	107°DB 83°WB	96°DB 80°WB	110°DB 83°WB	70.8 tons	1.4 tons/vehicle	6.46	\$23,500	\$1,680
4	100% fresh	Natural Draft Ventilated	Not processed	104°DB 82°WB	115°DB 84°WB	99°DB 81°WB	110°DB 83°WB	None	1.5 tons/vehicle	1.5	\$19,600	\$1,400

TABLE 4-1

Summary of Analysis of Alternate System Approaches to Vehicle Borne Heating and Cooling

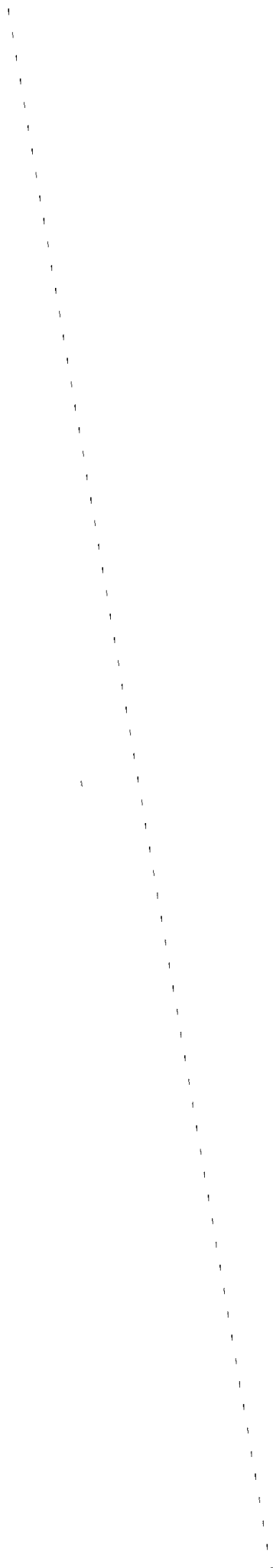

5.0 COMPONENT COST ESTIMATES

5.1 BACKGROUND:

The contract work objective was to provide system cost estimates in accordance with the following:

- A. Provide a breakdown of all system component costs obtained on this contract.
- B. Provide capital equipment cost estimates based on production quantities of all items obtained on this contract which are at the production prototype design level.

Under the contract, certain Uniflo system components were designed and built as prototype units for the functions of support, guidance, air distribution, acceleration, and braking.

The cost breakdowns reported in section 5.2 are based on actual costs incurred on this contract for building the prototype units. The costs include direct material and direct labor with overhead of 120% (less than the actual USC rate) and general and administrative expense of 20% (also less than the actual USC rate) as billed to the DOT on this contract before cost sharing. No profit is included in these costs.

5.2 SYSTEM COMPONENT COSTS:

The actual system component costs obtained on the contract are listed below. To facilitate visualizing the various components, refer to Figure 5-1, Uniflo System Components; Figure 5-2, Turbine Assembly; Figure 5-3, Vehicle Components; and Figure 5-4, Vehicle Thrust Bucket. Detailed descriptions of these components are given earlier in this report.

SUPPORT AND GUIDANCE

	Cost Per Module Two modules per 13'9" section of guideway. Based on Qty. of 8 Modules	
Guideway Cross Beams (Fig. 5-1)		
Direct Labor	\$ 43.88	
Overhead (120%)	52.66	
Direct Material	<u>87.55</u>	
	\$184.09	
General & Admin. Expense (20%)	<u>36.82</u>	
Total Cost of Structural Cross Beams		\$ 220.91
Bar Joist Assembly (Fig. 5-1)		
Direct Labor	\$195.80	
Overhead (120%)	234.96	
Direct Material	<u>337.07</u>	
	\$767.83	
General & Admin. Expense (20%)	<u>153.57</u>	
Total Cost of Sheet Metal Surfaces & Truss Supports		\$ 921.40
Guide Rail Assembly (Fig. 5-1)		
Direct Labor	\$ 52.49	
Overhead (120%)	62.99	
Direct Material	<u>73.51</u>	
	\$188.99	
General & Admin. Expense (20%)	<u>37.80</u>	
Total Cost of Guide Rails		\$ 226.79
Total Cost of Support and Guidance		<u>\$1,369.10</u>

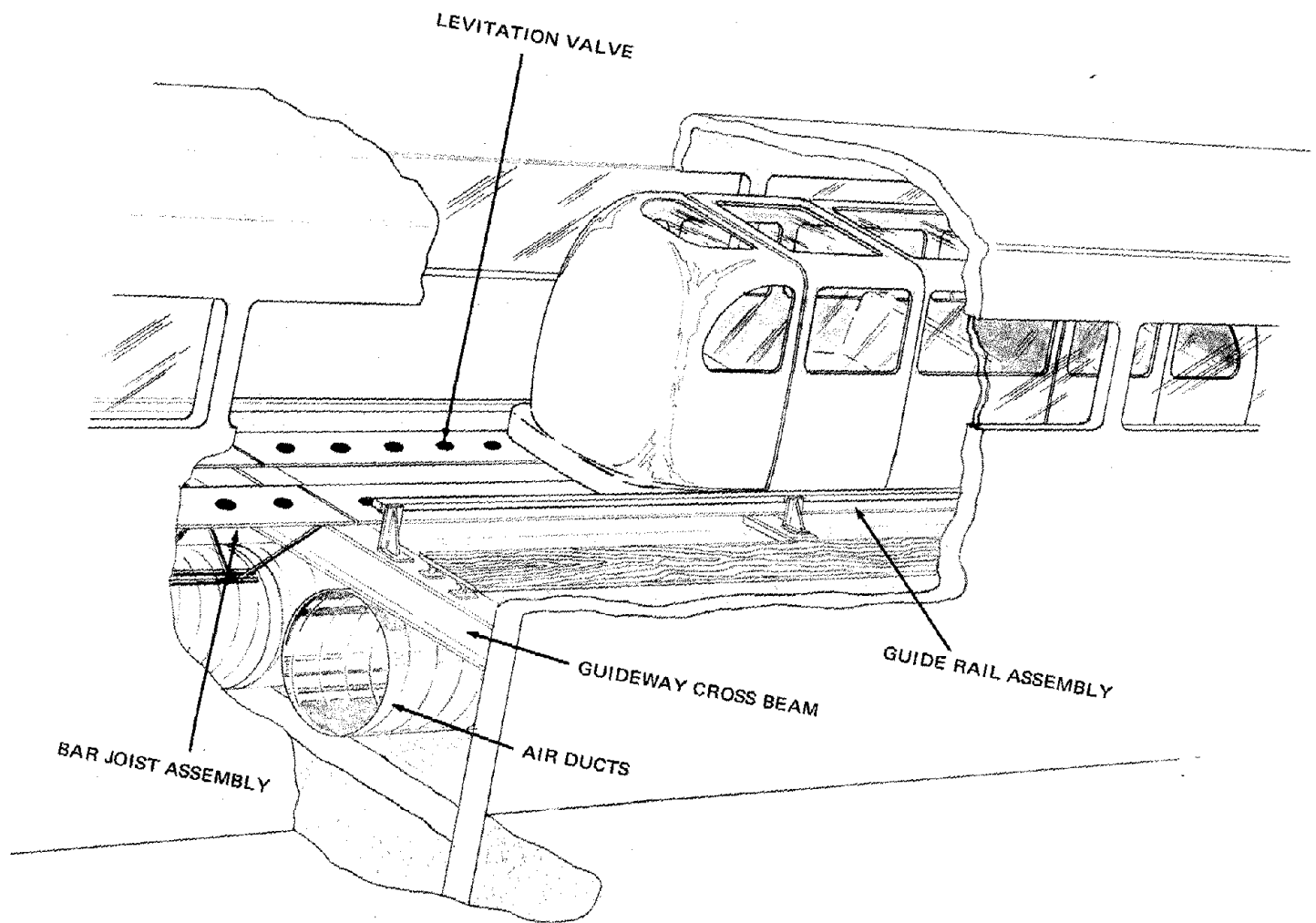

Figure 5-1. Uniflo System Components.

AIR DISTRIBUTION

	Cost Per Duct Based on 8 Modules Built
30" Dia. Air Ducts (Fig. 5-1)	\$ 82.80
Direct Labor	99.36
Overhead (120%)	<u>105.69</u>
	\$287.85
General & Admin. Expense (20%)	<u>57.57</u>
Total Cost of Air Distribution	<u>\$345.42</u>

ACCELERATION AND BRAKING

	Cost Per Assembly Based on 40 Modules Built
Turbine Assembly (Fig. 5-2) Guideway Mounted Element	
Direct Labor	\$ 57.20
Overhead (120%)	68.64
Direct Material	<u>32.42</u>
	\$158.26
General & Admin. Expense (20%)	<u>31.65</u>
Total Cost of Accelerator Module Assembly	<u>\$189.91</u>

VEHICLE COMPONENTS

	Cost Per Pad Assembly & Per Vehicle Based on Production for One Vehicle	
	Per Pad Assembly	Per Vehicle
Pad Mounting Base (Fig. 5-3)		
Direct Labor	\$119.92	
Overhead (120%)	143.90	
Direct Material	<u>* 10.80</u>	
	\$274.62	
General & Admin. Expense (20%)	<u>54.92</u>	
Total Cost of Pad Mounting	\$329.54	\$2,636.32
Levitation Pad (Fig. 5-3)		
Direct Labor	\$ 10.38	
Overhead (120%)	12.46	
Direct Material	<u>19.06</u>	
	\$ 41.90	
General & Admin. Expense (20%)	<u>8.38</u>	
Total Cost of Rubber Pad	\$ 50.28	\$ 402.24

*Excludes cost of castings furnished by USC

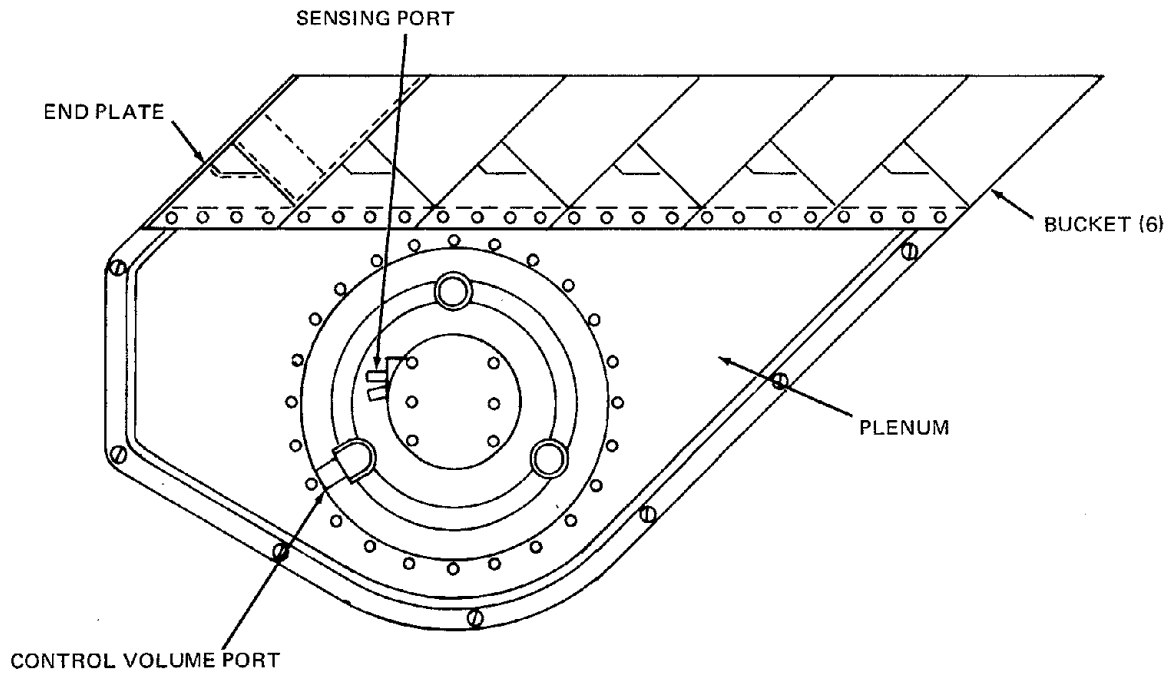
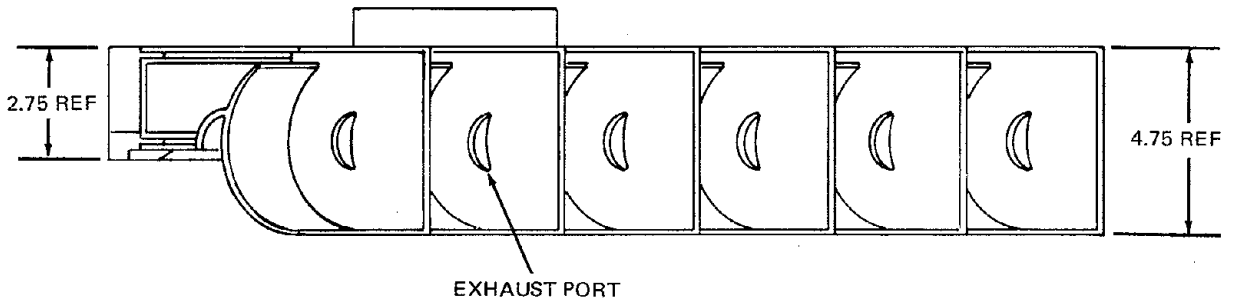
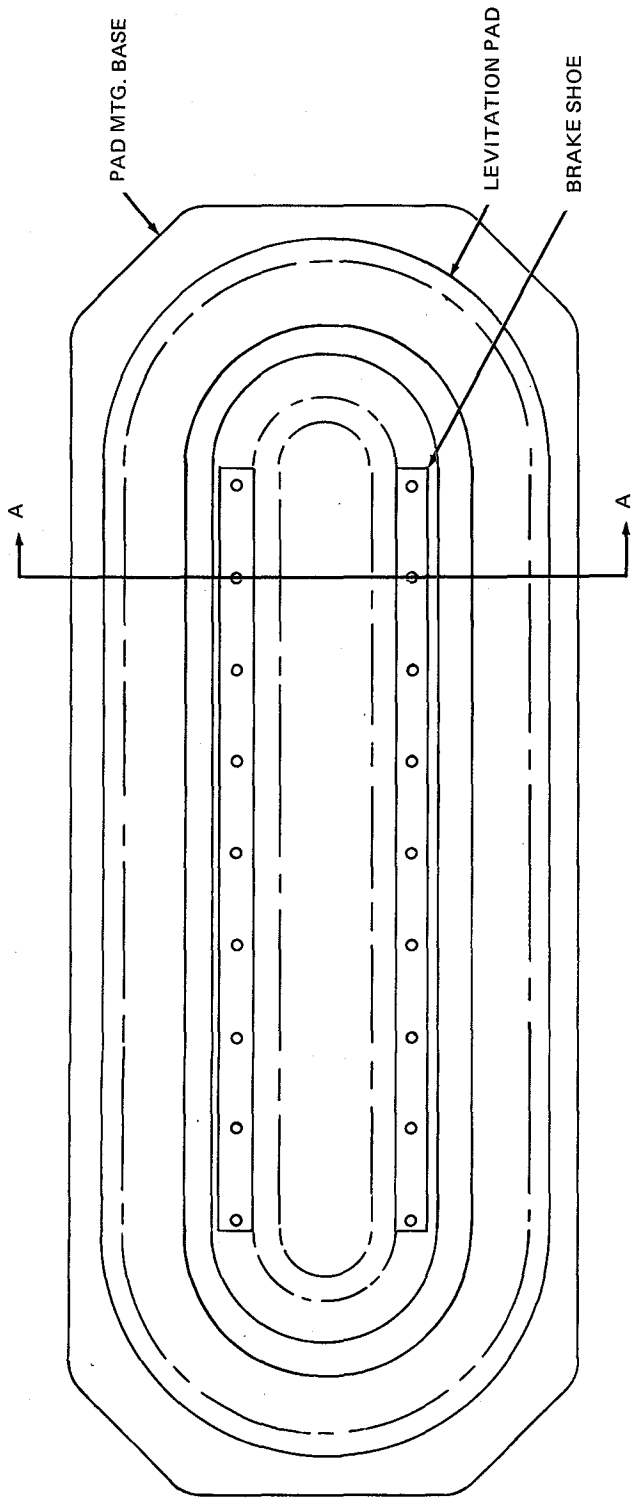

Figure 5-2. Turbine Assembly



BOTTOM VIEW

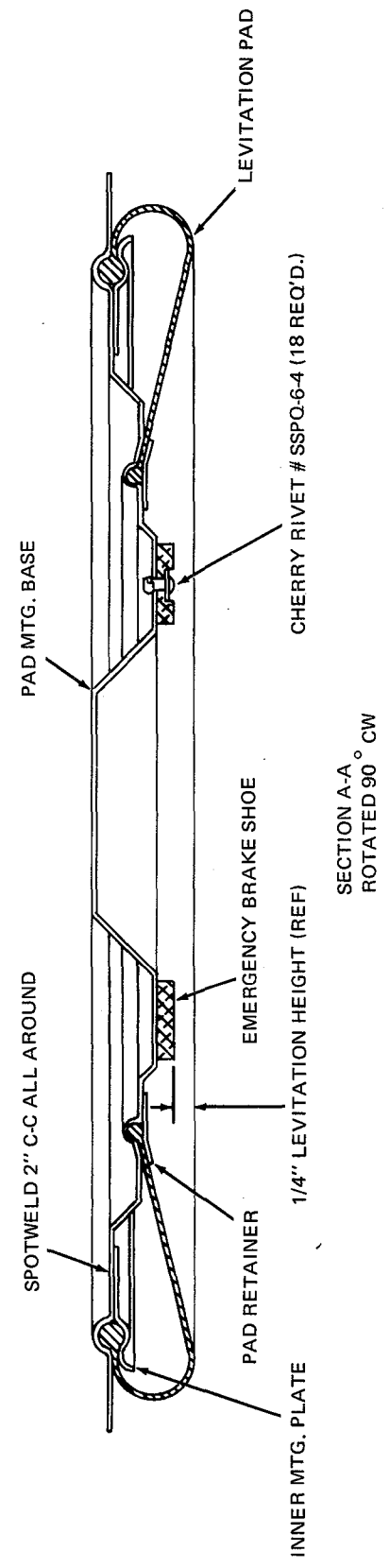

Figure 5-3. Vehicle Components.

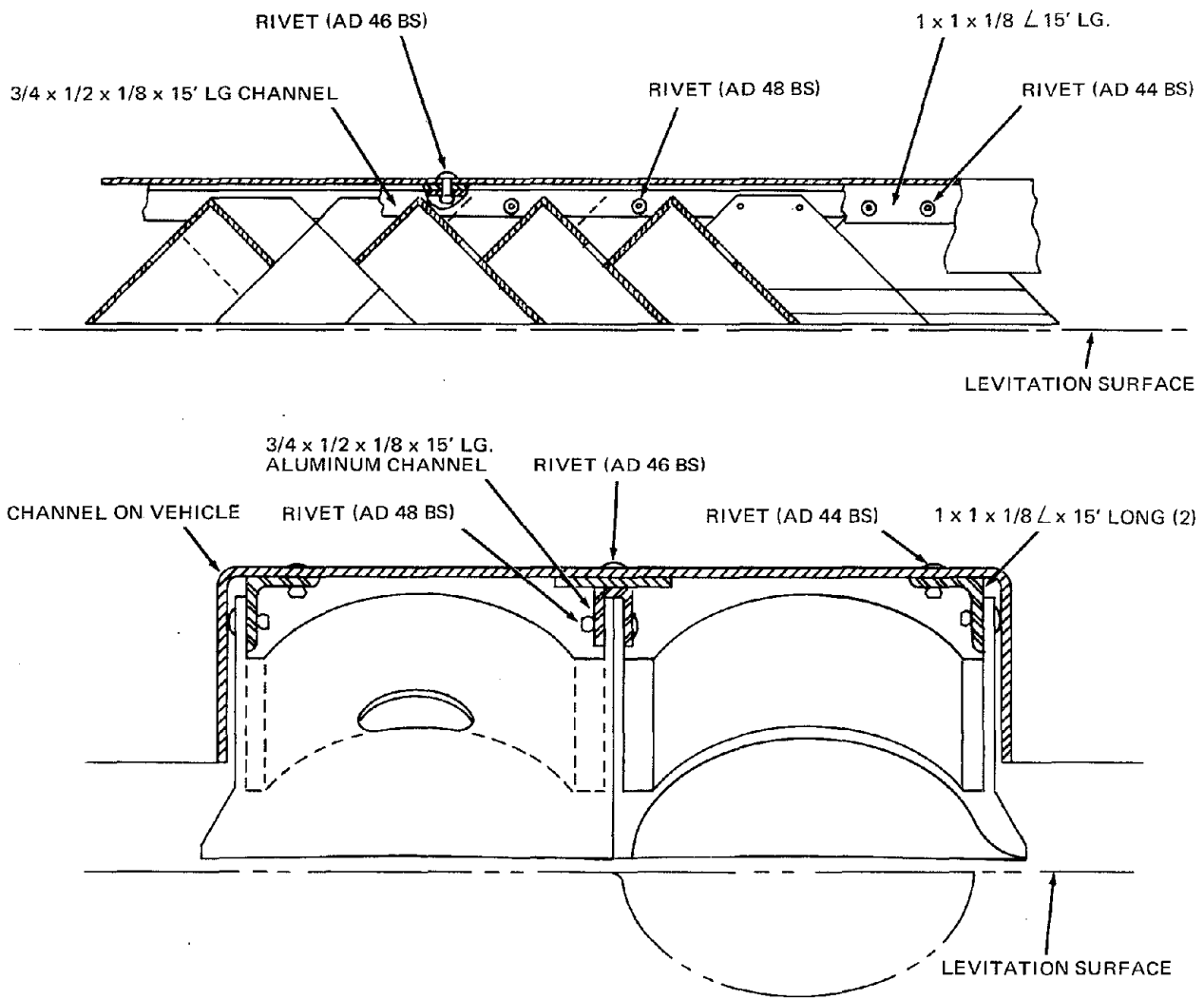

Figure 5-4. Vehicle Thrust Bucket

Brake Shoe (Fig. 5-3)		
Direct Labor	\$ 4.16	
Overhead (120%)	4.99	
Direct Material	<u>3.46</u>	
	\$ 12.61	
General & Admin. Expense (20%)	<u>2.52</u>	
Total Cost of Brake Shoe		\$ 15.13 \$ 121.04
Total Cost of Pad Assemblies		<u>\$394.95</u> <u>\$3,159.60</u>

Cost Per Vehicle
Based on Production for
One Vehicle

Vehicle Thrust Bucket Assembly (Fig. 5-4)	
Direct Labor	\$189.28
Overhead (120%)	227.14
Direct Material	<u>52.00</u>
	\$468.42
General & Admin. Expense (20%)	<u>93.68</u>
Total Cost of Vehicle Thrust Bucket Assembly	<u>\$562.10</u>

LEVITATION

Cost Per Valve
Based on 160 Valves Built

Levitation Valve Assembly (Fig. 5-1)	
Direct Labor	\$1.79
Overhead (120%)	2.15
Direct Material	<u>1.10</u>
	5.04
General & Admin. Expense (20%)	<u>1.01</u>
Total Cost of Levitation Valve Assembly	<u>\$6.05</u>

5.3 ESTIMATED CAPITAL EQUIPMENT COSTS

The following capital cost estimates cover the components of the Uniflo Personal Rapid Transit System, which have been developed to the production prototype design level. Two cost estimates are given for each component—one on a low production quantity, and the other on a normal production quantity. The system components estimated are only a portion of the total Uniflo Personal Rapid Transit System requirement. Consequently, the estimates do not constitute a total system cost.

The cost estimates prepared under the contract include the functions of support and guidance, air distribution, acceleration and braking, vehicle components, and levitation.

In order to establish a production quantity for estimating the cost of the components, a two-mile long demonstration system was assumed to be a reasonably sized system for estimating a typical low volume production quantity, and a twenty-mile long system was assumed for estimating a normal volume production quantity. After establishing the quantities involved, bids were secured from two different suppliers on each component, based on the quantities specified. These bids covered finished parts prepared for final assembly, and shipped to Uniflo Systems Company. The assembly costs were estimated by Uniflo Systems Company.

The estimated capital equipment costs are priced FOB Uniflo Systems Company, and do not include field installation.

SUPPORT AND GUIDANCE

	Cost Per Module	
	(768 per mile of one-way guideway)	
	Based on Qty. of 1,500 modules	Based on Qty. of 15,000 modules
Guideway Cross Beam (Fig. 5-1)	\$ 29.90	\$ 29.90
Bar Joist Assembly (Fig. 5-1)	293.00	253.00
Guide Rail Assembly (Fig. 5-1)	<u>47.30</u>	<u>45.70</u>
Total Cost Per Module	<u>370.20</u>	<u>328.60</u>
Average Cost Per One-Way Mile	<u>\$284,314.00</u>	<u>\$252,365.00</u>

AIR DISTRIBUTION

	Cost Per Duct Assembly	
	(768 per mile of one-way guideway)	
	Based on Qty. of 1,500 Units	Based on Qty. of 15,000 Units
30" Dia. Duct (Fig. 5-1)	\$ <u>167.00</u>	\$ <u>138.00</u>
Average Cost Per One-Way Mile	<u>\$128,256.00</u>	<u>\$105,984.00</u>

ACCELERATION AND BRAKING

	Cost Per Assembly	
	(Average 2,000 per mile of one-way guideway)	
	Based on Qty. of 4,000 Assemblies	Based on Qty. of 40,000 Assemblies
Turbine Assembly (Fig. 5-2)	\$ <u>66.30</u>	\$ <u>65.20</u>
Average Cost Per One-Way Mile	<u>\$132,600.00</u>	<u>\$130,400.00</u>

VEHICLE COMPONENTS

	Cost Per Vehicle	
	(Average 20 vehicles per mile of one-way guideway)	
	Based on 40 Vehicles	Based on 400 Vehicles
Levitation Pad Assembly (Fig. 5-3)		
Pad Mounting Base	\$ 110.20	\$ 24.60
Levitation Pad	18.80	17.70
Brake Shoe	11.02	10.71
Total Cost Per Pad Assembly	<u>\$ 140.02</u>	<u>\$ 53.01</u>
Total Cost Per Vehicle	<u>\$ 1,120.16</u>	<u>\$ 424.08</u>
Average Cost Per One-Way Mile	<u>\$22,403.00</u>	<u>\$8,482.00</u>

Note: Each vehicle requires 8 pad assemblies and 16 brake shoes.

Vehicle Thrust Bucket Assembly (Fig. 5-4)	<u>\$ 292.00</u>	<u>\$ 261.00</u>
Average Cost Per One-Way Mile	<u>\$ 5,840.00</u>	<u>\$5,220.00</u>

LEVITATION

	Cost Per Valve	
	(15,840 per mile of one-way guideway)	
	Based on Qty. of 30,000 Valves	Based on Qty. of 300,000 Valves
Levitation Valve Assembly (Fig. 5-1)	<u>\$ 4.31</u>	<u>\$ 2.53</u>
Average Cost Per One-Way Mile	<u>\$68,270.00</u>	<u>\$40,075.00</u>

5.4 SUMMARY AND CONCLUSIONS

	Actual Component Costs	Estimated Production Cost
Guideway Cross Beam	\$ 220.91	\$ 29.90
Bar Joist Assembly	921.40	253.00
Guide Rail Assembly	226.79	45.70
30" Air Ducts	345.42	138.00
Turbine Assembly	189.91	65.20
Pad Mounting Base (per Vehicle)	2,636.32	196.80
Levitation Pad (per Vehicle)	402.24	141.60
Brake Shoe (per Vehicle)	121.04	85.68
Vehicle Thrust Bucket (per Vehicle)	562.10	261.00
Levitation Valves (per valve)	6.05	2.53

The actual component costs cited above were costs incurred when building the prototype units under this contract. The estimated production component costs are based upon quantities sufficient for the construction of a twenty-mile-long system.

Summarized, on the basis of potential cost on a per-mile basis, estimated costs are:

<u>Component Description</u>	<u>Average Cost per Mile of One-Way Guideway</u>	
	<u>Based on 2 Mi.</u>	<u>Based on 20 Mi.</u>
Operating Surface w/air Supply Piping	\$412,570	\$358,349
Accelerator Assemblies	132,600	130,400
Vehicle Components –		
Levitation Pads, Brake Skids and Accelerator Buckets	28,243	13,702
Levitation Valves	68,270	40,075
Total	<u>\$641,683</u>	<u>\$542,526</u>

The Uniflo Systems Company has made numerous system capital cost estimates in the past. Comparing these prior component estimates with the above component estimates, the following is observed:

	<u>Average Cost per Mile of One-Way Guideway</u>	
	<u>Based on 2 Mi.</u>	<u>Based on 20 Mi.</u>
Prior estimates of operating surface, piping, accelerators, vehicle components, and levitation valves.	\$1,055,400	\$1,055,400
Current estimates per above	<u>641,683</u>	<u>542,526</u>
\$ Reduction	<u>\$ 413,717</u>	<u>\$ 512,874</u>
% Reduction	40	49

This gratifying reduction in estimated cost of a significant portion of the Uniflo system costs lends confidence that prior overall Uniflo system cost estimates have been conservative. Further, the marked reduction in estimated production costs of the components examined under this contract indicate promise that other components of the Uniflo system may be amenable to similar cost improvement.

6.0 SYSTEM PERFORMANCE INFORMATION

6.1 BACKGROUND

Low speed operating information on the Uniflo system was obtained by operating an instrumented Uniflo vehicle on an 87 ft. long section of guideway. As required under the contract, the data gathered covers the areas of passenger ride quality, linear turbine performance, and emergency braking rates. As described in Section 1.0 of this report, the guideway consists of 55 ft. of steel Uniflo guideway, and 32 ft. of wood guideway to be used as a runout area. The steel guideway is equipped with continuous forward turbines to accelerate the vehicle toward the runout section, where an arresting system stops the vehicle and returns it to the steel guideway, at which time dynamic or emergency braking can be deployed. Figures 6-1 and 6-2 show the operation. The vehicle used for these tests is described in Section 2.0 of this report, and is basically an experimental 8-passenger vehicle.

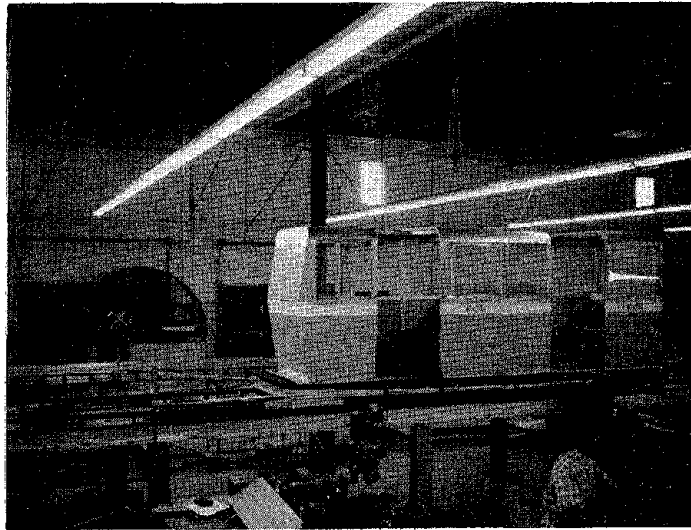

Figure 6-1. Vehicle entering arresting mechanism.

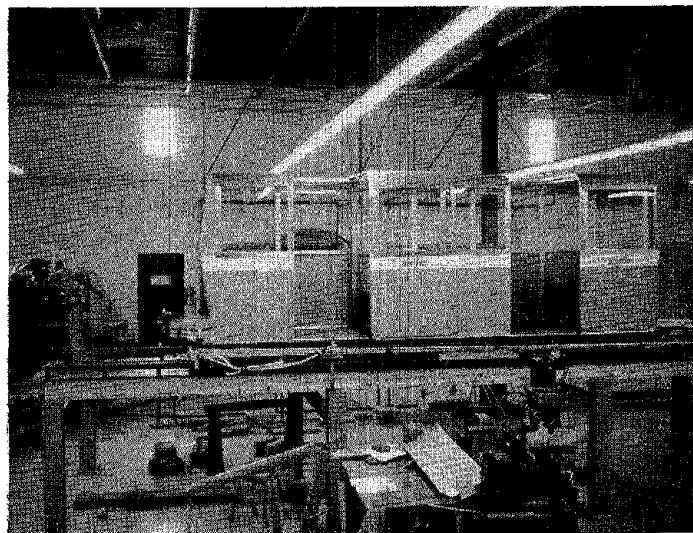

Figure 6-2. Vehicle with arresting mechanism fully extended.

6.2 TEST INSTRUMENTATION AND CONDITIONS

6.2.1 Instrumentation:

Since the runs were of short duration and not steady state, it was decided to record all data simultaneously. To do this a Honeywell 8" Visicorder was selected to be the recording instrument. Seven measurement channels were used. The measurement and transducer are listed below:

- Channel A Differential pressure on orifice plate to measure air flow with a Satham PM 96TC - 1-350 differential pressure transducer (range ± 1 psid)

- Channel B
and D Vertical and lateral acceleration with a Satham A 5-2-350 accelerometer (range $\pm 2g$)

- Channel C Longitudinal acceleration with a Satham A45-2-350 accelerometer (range $\pm 2g$)

- Channel E Levitation pad pressure with a Satham PM 73063 ± 3 -350 pressure transducer (range ± 3 psid)

- Channel F Vehicle velocity with a Dynalco Corporation, Model T421 tachometer connected to a drive wheel

- Channel G Position on the guideway detector using a photo transistor and metal tabs. Position marked every foot.

The accelerometers were attached to a wood block, and then to a metal bar. This bar was attached to the main support frame of the superstructure. Figure 6-3 shows the installation. The tachometer was installed in the vehicle, and is shown on Figure 6-4. The position detector is shown in Figure 6-5. The pad pressure transducer was installed in the vehicle. All the vehicle mounted transducers were routed to an interconnection and signal conditioning instrument.

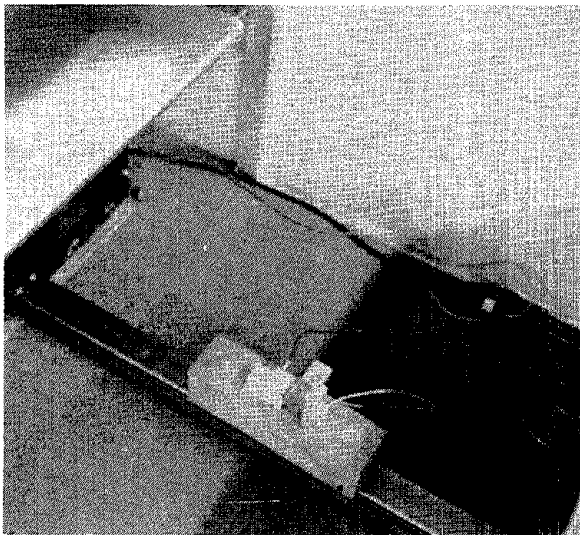

Figure 6-3. Accelerometer Installation.

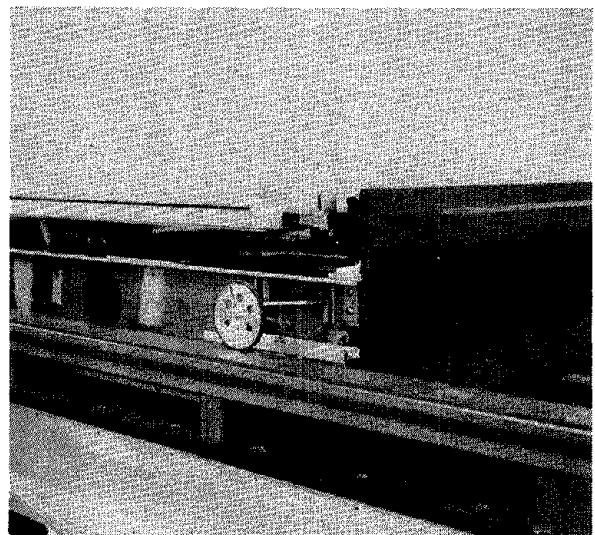

Figure 6-4. Tachometer.

The signal conditioning was accomplished by the addition of passive resistive components to adjust zero and full scale values of the transducers. From the signal conditioning instrument the outputs were fed directly to the Visicorder galvanometers. The Visicorder and 10 volt power supply were mounted in the vehicle, and power was supplied by cable running along the guideway. A separate cable from the orifice plate differential pressure transducer also ran along the guideway and was connected to the Visicorder. The power cable arrangement is shown in Figure 6-6. The test equipment in the vehicle is shown in Figure 6-7.

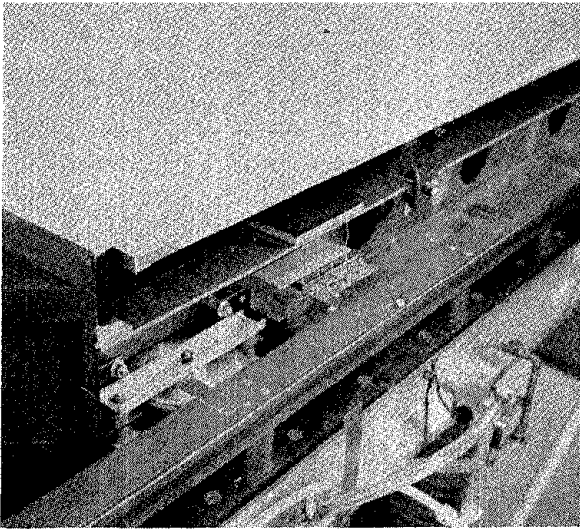

Figure 6-5. Position Detector

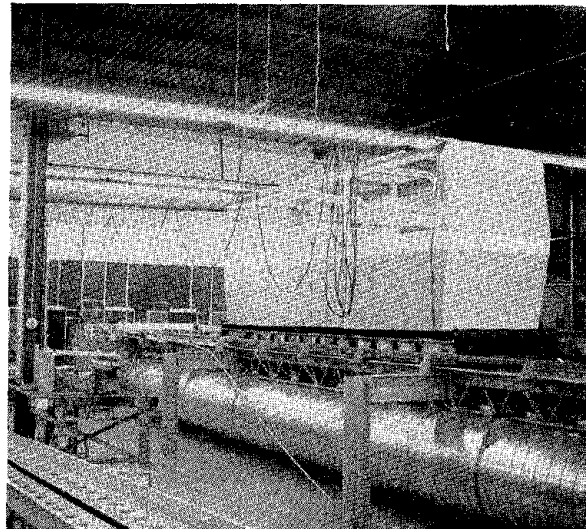

Figure 6-6. Power Cable Arrangement

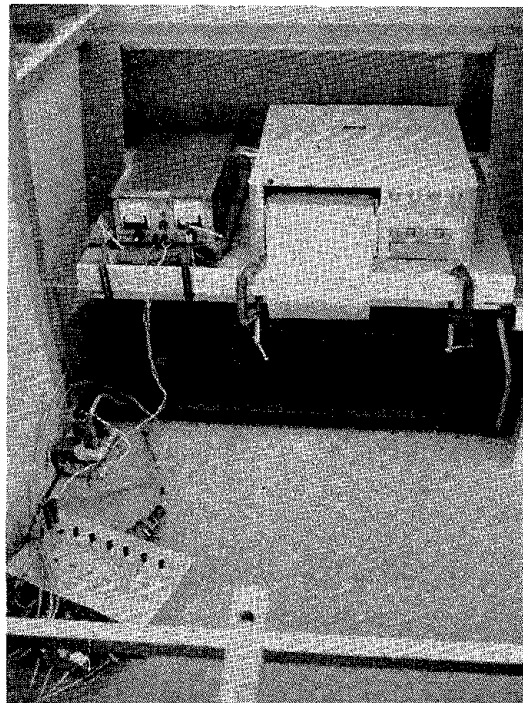

Figure 6-7. Vehicle Borne Test Equipment.

This page is reproduced at the back of the report by a different reproduction method to provide better detail.

The Visicorder galvanometers were M5000 used on the position detector channel. The three acceleration channels used M24-350 with a damping factor of 1.15. This gave a frequency response whose amplitude was down 7% at 5 Hz, 21% at 10Hz, and 49% at 20 Hz.

The three remaining channels used M100-350 galvanometers. The orifice differential pressure channel had its frequency response lowered by orifice and volumes added in series with each input. This was to reduce the large noise present in the orifice plate measurement. The response time for the differential pressure measurement was .28 seconds for 63.2% response.

The orifice itself is 11 inches in diameter with a vena contracta tap.

Electrical power input was measured with a General Electric Model Type AB-40 Watt meter.

Miscellaneous instrumentation included a Fairbanks balance beam scale, 0 to 900 lbs., Dwyer 0-2 psi magnehelic pressure gauges, 80 in. and 140 in. water manometers, and several spring scales.

6.2.2 Test Conditions

The weight of the vehicle was determined by weighing an empty vehicle with the Fairbanks scale, one end at a time, as shown in Figure 6-8. Materials added after the weigh-in were weighed and added. Final weight of the completed vehicle with seats installed is 1,400 lbs. The instrumentation package is 110 lbs. For empty vehicle tests, one seat was removed to get a gross of 1,500 lbs. 1,700 lbs. in the form of eight 212 lb. load boxes were installed (see Figure 2-4) to get a maximum gross weight of 3,200 lbs. for full vehicle tests. With the 4,000 in.² of pad area, this gave nominal pad pressures empty and full of .38 and .80 psi respectively. These pressures were confirmed by the pad pressure data.

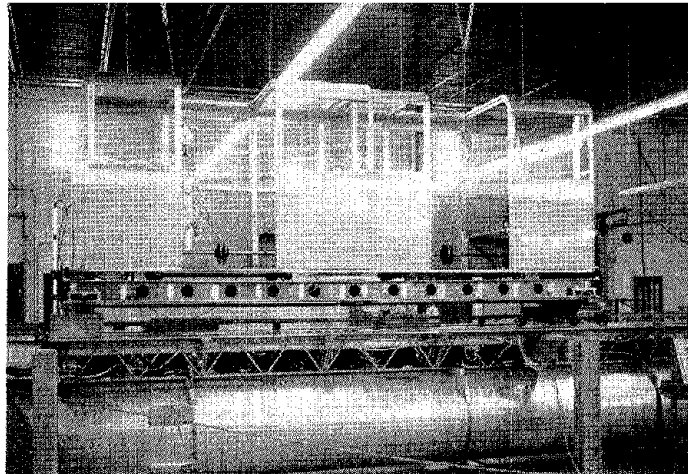

Figure 6-8. Vehicle Weighing Set-up.

Electrical power in, air power in, and various pressures were monitored for three conditions of the system. This data is shown in Table 6-1. Condition A and condition C are approximately the same, and give about 2 1/4 psi supply pressure during full acceleration conditions. Condition A had the inlet duct disconnected for the acoustical tests (the inlet is terminated inside the building which added an unrealistic amount of noise) and shows somewhat higher pressures and flows during full acceleration. Condition B has the inlet vanes set so as to get minimal blower surge at idle, but this caused unacceptably low pressure at full thrust. Most testing was done with condition C, and the data was used for various calculations.

Of primary interest in the Table 6-1 is the 195 HP electrical input power with only 52 air horsepower input to the system. About 20 HP of the loss is caused by the air bled to prevent blower surge, and another 6 HP is lost across the measuring orifice. The electric motor is 83% efficient, so this leaves a blower efficiency of 48%. This must be improved for future installation by working closely with a blower manufacturer to get a blower that will operate in the required pressure flow range without surge.

determined from the accelerometer readings for the reverse, low speed, and max speed curves, using a vehicle weight of 3,200 lbs. The average acceleration, A_a was determined from the formula:

$$A_a = \frac{V_f^2 - V_i^2}{2 X}$$

Where:

V_i is the speed of the vehicle at the 1 foot marker.

V_f is the speed of the vehicle at the 38 foot marker.

X is the distance between the markers (37 ft.).

The curve for the average thrust shows that for $\pm 1/4''$ displacement, there is a 15% fall-off in thrust. For $+ 1/8''$ displacement, there is a 7% decrease, and for $- 1/8''$ displacement, there is a 2% increase in thrust.

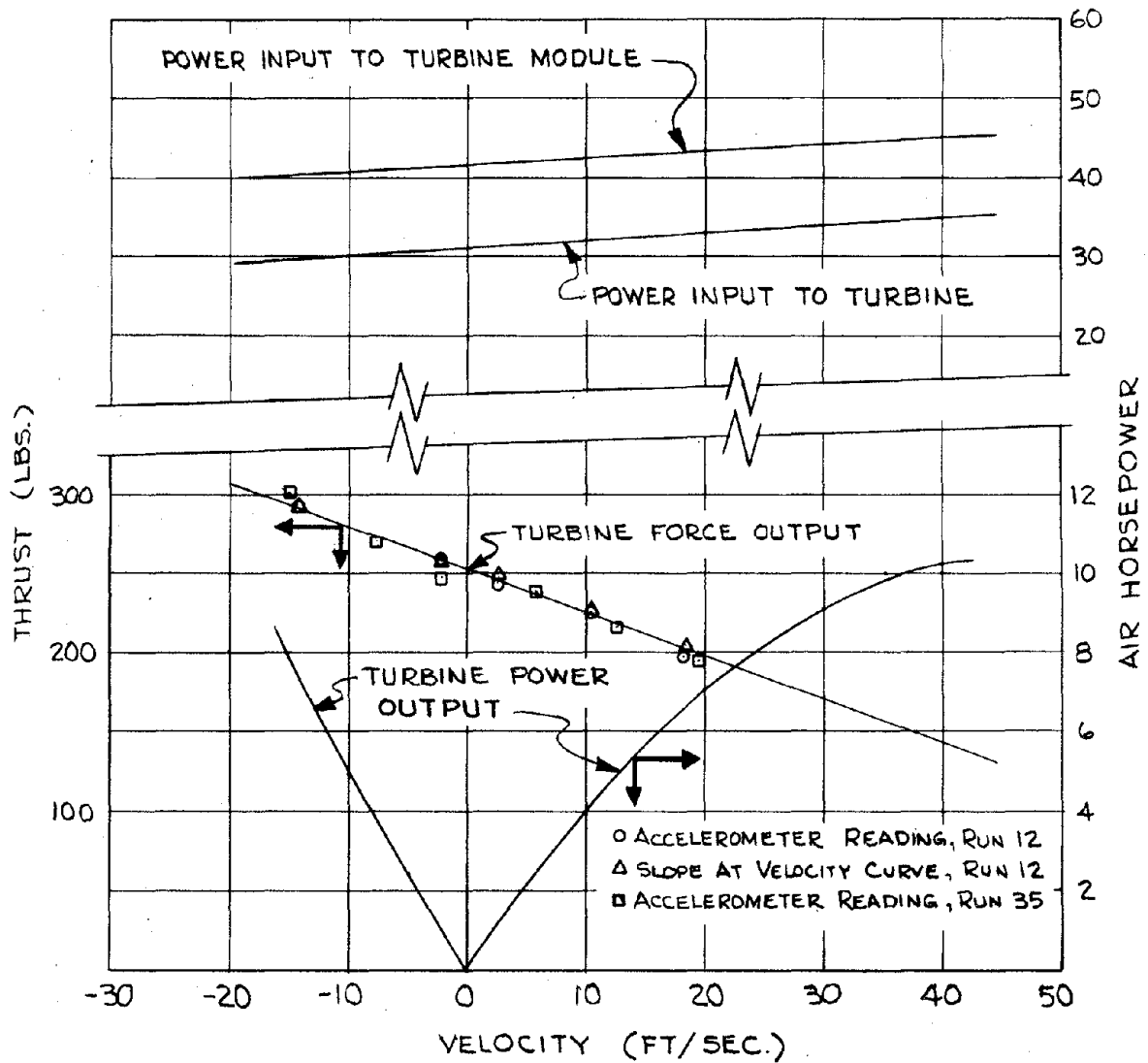

Figure 6-9. Turbine performance versus velocity.

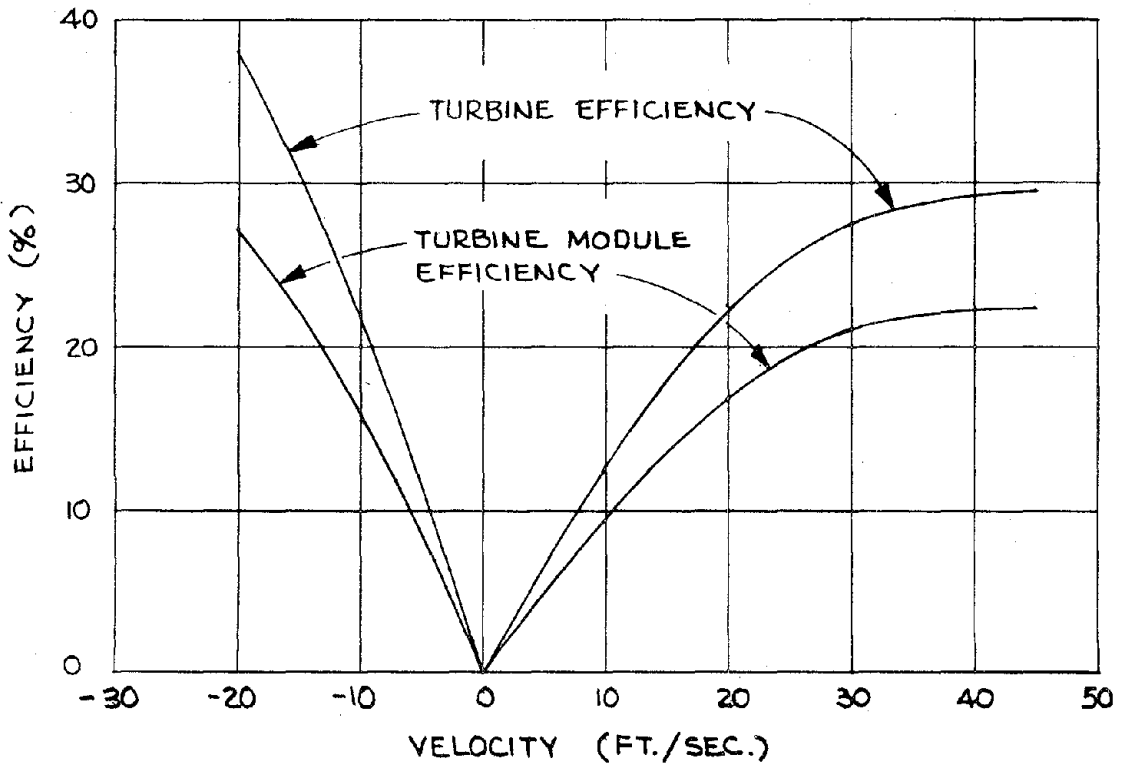

Figure 6-10. Turbine efficiency versus velocity.

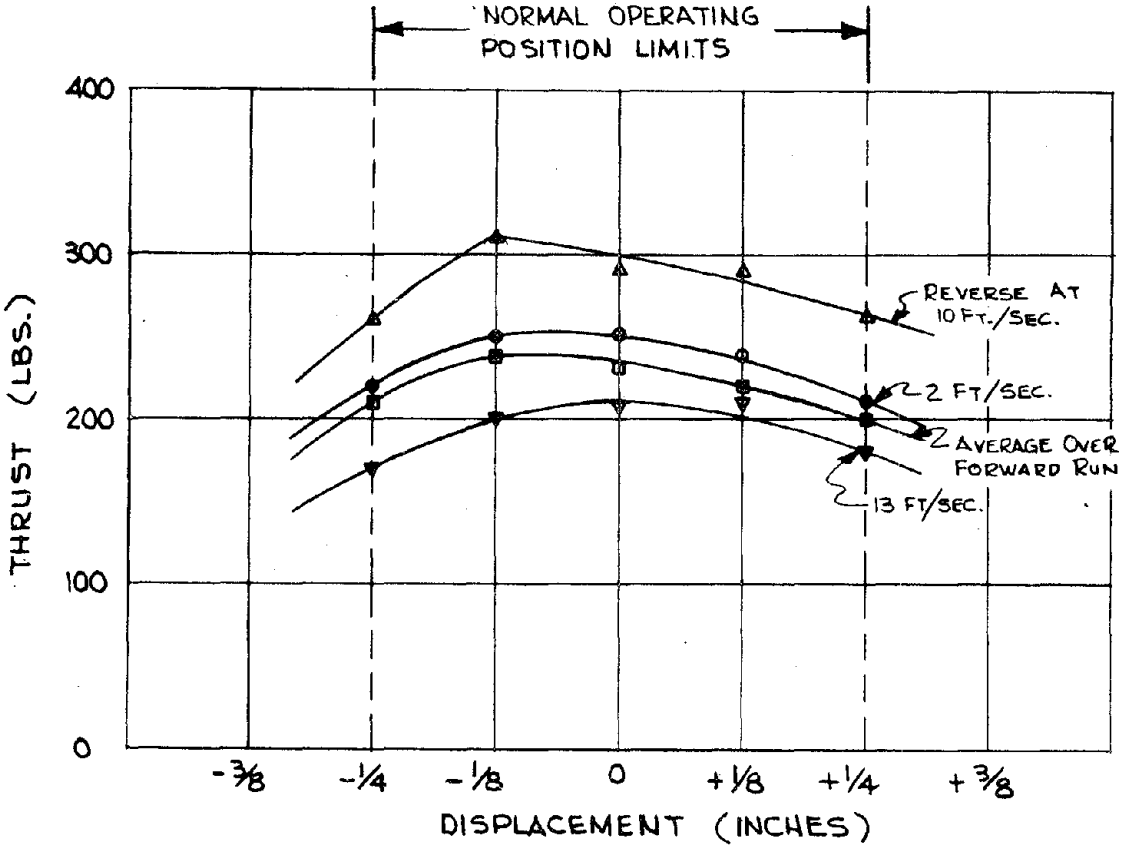

Figure 6-11. Thrust versus lateral displacement of vehicle.

6.4 RIDE QUALITY

The ride quality for 3 axis vibrations for both empty and full vehicles was measured using the three accelerometers. Typical data for an acceleration and emergency braking run is shown in Figure 6-12. The three acceleration axes are plotted for the complete run. Velocity of the vehicle and position data are also shown. The data was roughly analyzed manually to determine the amplitude and frequency of the pure sinusoid vibrations that were present and is presented in Table 6-2. This data was compared to the lower limiting value of the "reduced comfort region" of the tentative ISO¹ standards for urban trips (1 hour exposure) shown in Figure 6-13. The results show that heavy vehicles meet the proposed standards. The empty vehicle had a problem with lateral vibration which for some reason coupled with the longitudinal axis to also cause an excess in that direction. The test vehicle guide rollers are rigidly mounted with the vehicle having a nominal guide rail clearance of 1/8". As shown in the data, a reduction of this clearance to 1/16" largely solved the problem. For a production vehicle, a rudimentary elastic suspension should solve the problem.

TABLE 6-2 RIDE QUALITY

Vehicle Condition	Frequency - Amplitude		
	Vertical	Longitudinal	Lateral
Full Vehicle - 15 ft./s Run # 38	20 Hz - .06 g	10 Hz - .02 g 18 Hz - .02 g	10 Hz - .03 g 15-20 Hz - .03 g
Empty Vehicle - 20 ft./s Run # 41	9 Hz - .06 g 20 Hz - .06 g 48 Hz - .06 g	<u>13 Hz - .07</u> 28 Hz - .025	<u>13 Hz - .4 g</u> <u>20 Hz - .08 g</u>
Full Vehicle - Emergency Braking - Run # 39	1/3 Hz - .05 g 18 Hz - .038	5 Hz - .03 g 8 Hz - .025 g	10 - 20 Hz - .02 g
Empty Vehicle - Emergency Braking-Run # 41	7 Hz - .02 g 19 Hz - .06 g	<u>13 Hz - .06 g</u>	<u>13 Hz - .3 g</u> 20 Hz - .04 g
Full Vehicle - Dynamic Braking - Run # 38	20 Hz - .05 g	10 Hz - .01 g 18 Hz - .03 g	9 Hz - .025 g 15 Hz - .015 g
Empty Vehicle - Dynamic Braking - Run # 40	18 Hz - .05 g 48 Hz - .21 g	<u>12 Hz - .06 g</u> 42 Hz - .09 g	<u>12 Hz - .3 g</u> <u>23 Hz - .1 g</u>
Empty Vehicle - Dynamic Braking -- Clearance on side guidance reduced to 1/16" Run # 42	7 Hz - .05 g 48 Hz - .15 g	10 Hz - .035 g 18 Hz - .06 g	<u>7 Hz - .09 g</u> 16 Hz - .05 g

Underlined values exceed tentative ISO standards (lower limit of reduced comfort) for urban trips (1 hour exposure). (See Figure 6-13)

Double underlined values grossly exceed tentative ISO standards.

¹ *A Study for the Selection of an Intermediate Capacity Public Transit System*,
Department of Transportation and Communications, Ontario, Canada, January 1972.

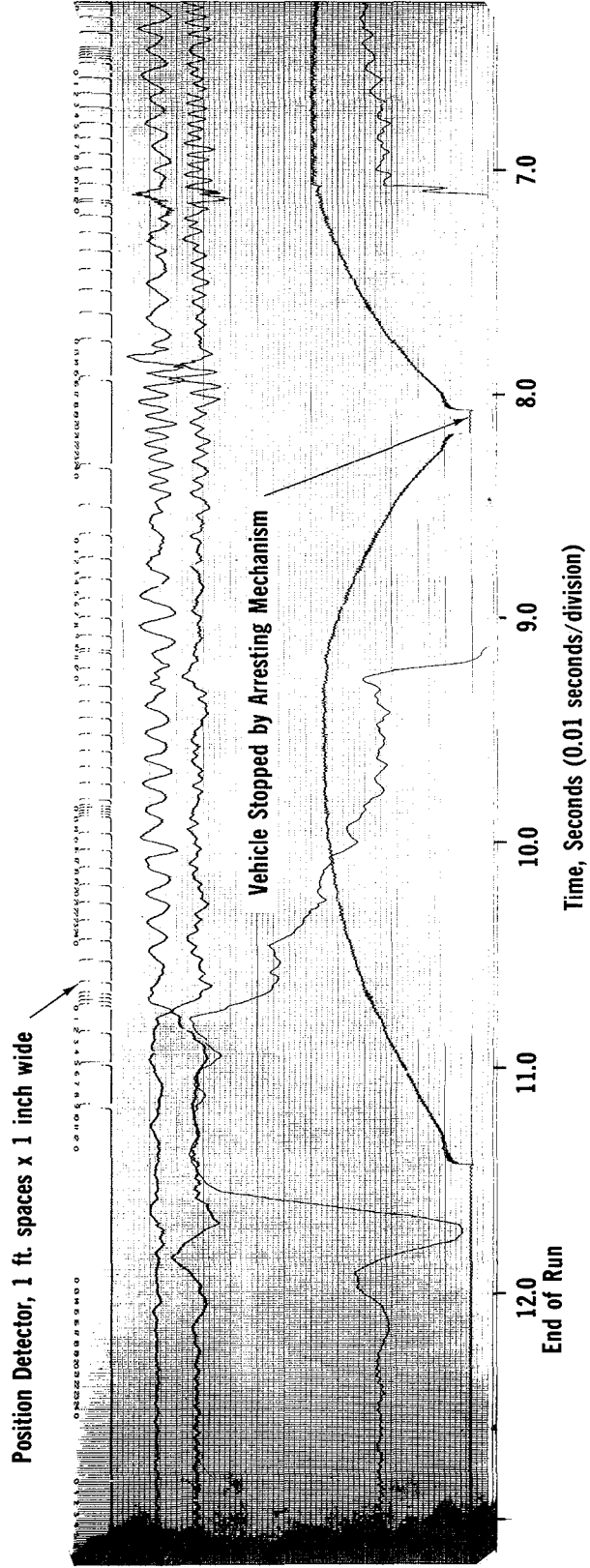
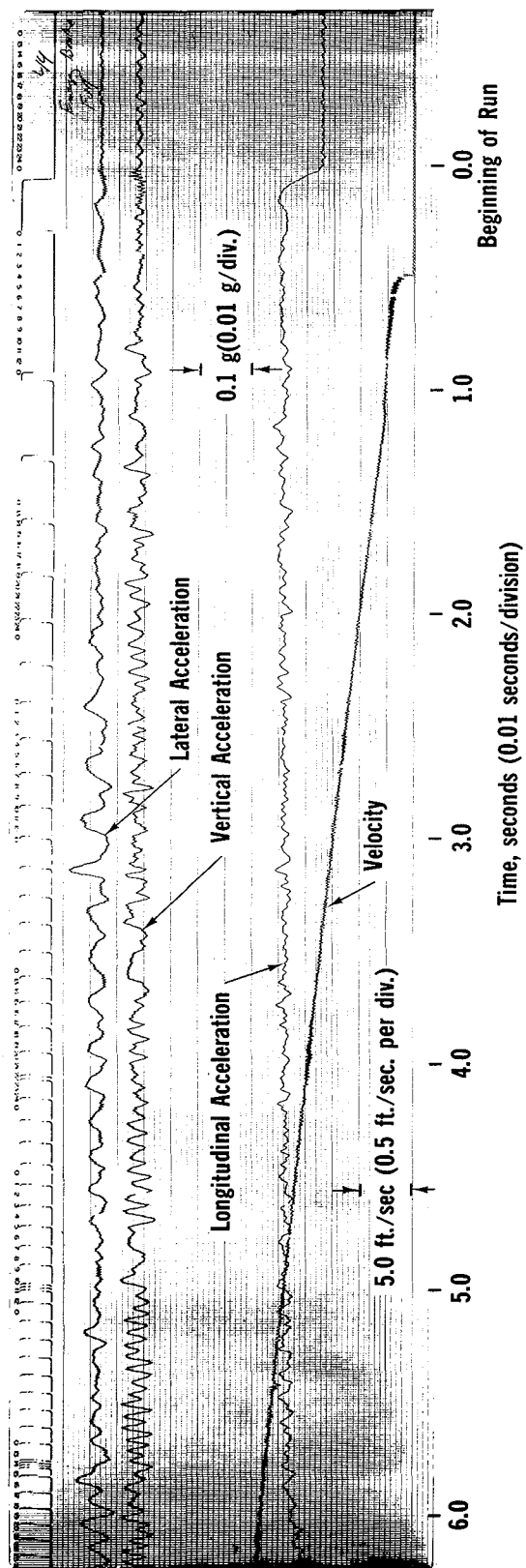

Figure 6-12 Data Plot of a Typical Run With Emergency Braking and a Full Vehicle

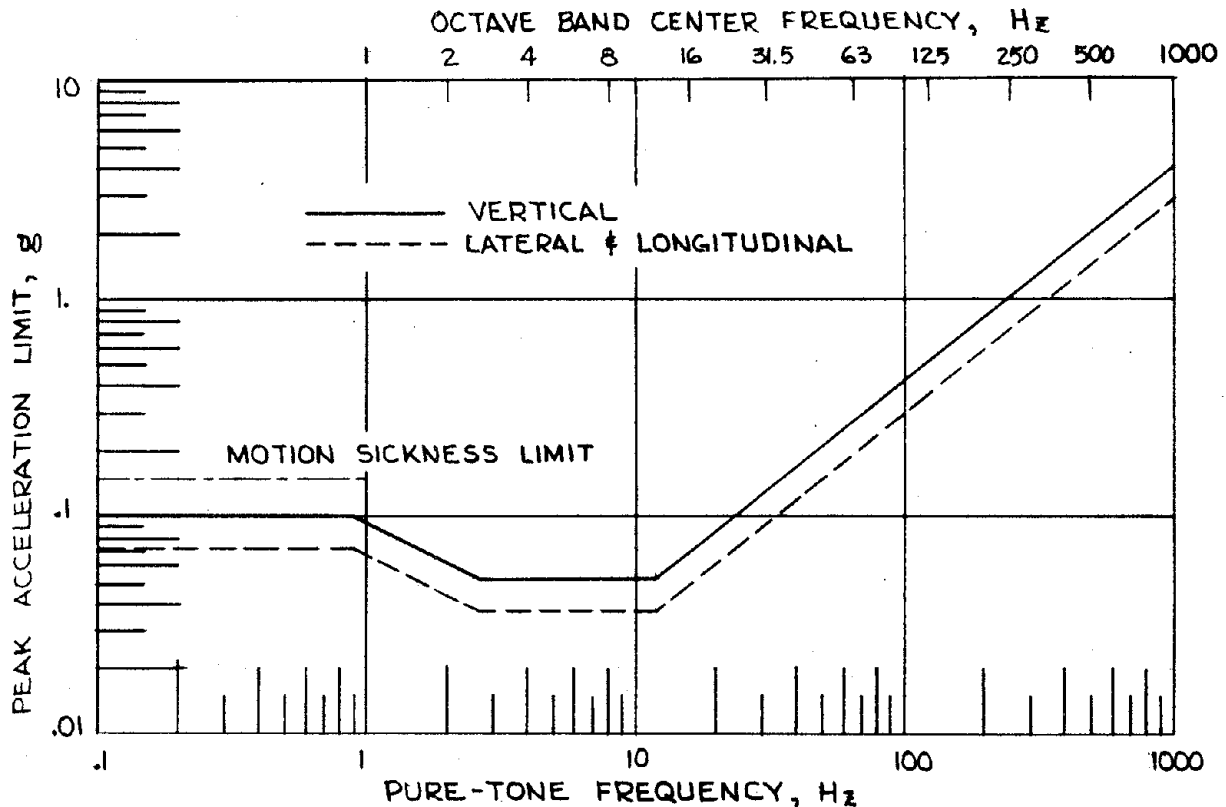

Figure 6-13. Permitted maximum vertical and lateral/longitudinal vibration levels on urban trips.

(These levels are applicable for one pure-tone excitation occurring within the above frequency range. Same criteria apply to persons standing or sitting.)

6.5 EMERGENCY BRAKING

Data on emergency braking was obtained from the longitudinal accelerometer traces. The coefficients of friction were obtained from the acceleration levels and the jerks were obtained from the slope of the acceleration levels. The data is presented in Table 6-3. For the Uniflo system type of emergency braking, the deceleration is given directly by the coefficient of friction, i.e., a coefficient of .4 gives a .4 g deceleration. The data for friction coefficient shows that it is practical to get emergency braking rates from .2 g to .4 g. The initial jerk is shown for different conditions and brake materials. Normal operation would be the first one listed, i.e., the vehicle sliding onto a level section with the air conditioning bleed open. These jerk levels recorded did not appear to be excessive by people riding the vehicle. Jerk level is seen to be proportional to friction coefficient. Because the bleed-off affects the time for the vehicle to settle, the jerk levels are lower with the bleed closed off. The instant stop condition results in fairly high jerk levels. The final jerk for this type of braking is seen to be quite high. Though very noticeable, persons riding the vehicle felt the high final jerk rates were acceptable.

TABLE 6-3 EMERGENCY BRAKE DATA

	HWM Polyethylene Hercules 1900		Raybestos 3350-0		Mixture of 1/2 of Each	
	Light	Heavy	Light	Heavy	Light	Heavy
Coefficient of friction:						
Initial	.15	.19	.43	.42	.33	.34
Final	.21	.21	.40	.41	.33	.34
Initial Jerk						
With bleed (a)	.14 g/s	.13 g/s	.47 g/s	.40 g/s	.23 g/s	.25 g/s
Without bleed (b)	.10 g/s		.34 g/s	.29 g/s		
Instant stop (c) - with bleed	.89 g/s	.71 g/s	1.9 g/s	1.5 g/s		
Instant stop (c) - without bleed	.16 g/s		.55 g/s	.63 g/s		
Final Jerk	3.3 g/s	2 g/s	6.5 g/s	4.0 g/s	5.4 g/s	2.9 g/s

- a. With bleed refers to the air conditioning ports being open to atmosphere.
- b. Without bleed refers to the air conditioning ports being closed.
- c. Instant stop refers to a section being turned off when the vehicle is on it. In a normal emergency stop, the vehicle runs onto a dead section.

6.6 CONCLUSIONS AND RECOMMENDATIONS

In general, the tests showed very good results with the system components performing as expected. The vehicle suspension gave an acceptable ride with only a minor problem with lateral vibration that can easily be remedied. The levitation pads had very low drag, were stable, and have fast response. The emergency braking system works well, and can give any desired braking rate. Jerk levels are high, but appear to be acceptable. The turbine output falls off at an acceptable rate with speed, and has better than expected tolerance to misalignment. The blower system efficiency and the turbine module output were the main items where performance was below expected levels. The blower will require special design work by the manufacturer, as at present, the Uniflo requirements are considerably different from the usual. With proper design, an operating efficiency of 70-80% instead of 48%, should be achievable, as well as a considerable reduction in idle horsepower. The main problem with the turbine module was a number of small dimensional deficiencies which added up to cause a large reduction in the turbine valve area. Design pressure drop across the valve was to be .2 psi, while the actual pressure drop was .6 psi. This deficiency can be corrected in the next units fairly easily. The turbine itself puts out about 10% less thrust than expected. Various non-idealities occurred in the construction and installation that are the most probably causes of this loss. Care must be taken in future units to keep them aerodynamically clean and mounted squarely.

The next stage in performance testing should test components at higher speeds. The suspension should be tried around curves, and the pads should be life tested at speed. This implies a long test track with bi-directional capability or a continuous loop system. The turbine module should be redesigned with a goal of increasing output to more than 40 lbs. of static thrust. Design improvements must also be made to increase efficiency and decrease noise. These improvements will come mainly in the areas of nozzle and bucket design.

LIST OF REFERENCES USED FOR SECTION 4.0 AIR CONDITIONING STUDY AND APPENDIX B

1. *Fan Engineering*, Sixth Edition – Buffalo Forge Company
2. *Handbook of Engineering Fundamentals*, College Edition – Ovid W. Eshbach
3. *Heating and Air Conditioning* – Burgess H. Jennings
4. *Principles of Engineering Heat Transfer* – Warren H. Giedt, PhD
5. “Cooling Coils for Water and Refrigerant, Comfort and Process” – The Trane Company
6. “Direct Expansion Cooling Surface” – Aerofin Corporation Bulletin DP-66
7. *Ashrae Handbook of Fundamentals*, Heating, Refrigerating, Ventilating and Air Conditioning – American Society of Heating, Refrigerating and Air Conditioning Engineers, Inc. 1972
8. *Ashrae Guide and Data Book, Systems and Equipment*, Heating, Refrigerating Ventilating and Air Conditioning – American Society of Heating, Refrigerating and Air Conditioning Engineers, 1967.

LIST OF REFERENCES USED FOR SECTION 3.0, SYSTEM NOISE EMISSIONS

9. *A Study for the Selection of an Intermediate Capacity Public Transit System*, Ontario Ministry of Transportation & Communications, Ontario, Canada, January, 1972.
10. *Noise Reduction*, Leo L. Beranek, McGraw Hill 1960.
11. Report No. OST-ONA-70-2, April 1970, Technical Report: *Evaluating the Noises of Transportation*.
12. *Rapid Transit Noise and Vibration*, P.W. Wilson (1971), presented at the Rail Transit Conference at ATA, April.
13. *Rail Vehicle Noise*, T.D. Norwood, Research paper No. 155 of Division of Building Research, National Research Council of Canada, Ottawa, 1963.



APPENDIX A

REPORT OF INVENTIONS APPENDIX

It is believed that no significant patentable improvements to Uniflo system components were developed during the execution of Contract DOT-TSC-367.

Two noteworthy innovations or improvements were applied during the development and testing under this contract:

1. Vehicle Test Rebound Mechanism, described in Section 1.0, Guideway Operating Surface, in the body of the report.

This device enabled testing normally requiring nearly twice the amount of track utilized in this contract. Its further use is proposed for any follow-on testing at higher speeds.

2. Restart for Levitation Pad Assembly, described in Section 2.0, Full Scale Test Vehicle, in the body of the report.

This simple relief valve provides restart assurance on all pads of a track air source multipad levitation system with integral vehicle ventilation air flow. This device was first described in an internal Uniflo Systems Company R & D report for the month of April, 1971.

APPENDIX B

HEATING, VENTILATING, AND AIR CONDITIONING STUDY CONSIDERATIONS

This appendix contains discussions considering:

1. Solar Heat Load
2. Vehicle Ventilation
3. Heat Sink Unit
4. Station Refrigeration System for Recharging Vehicle HS Unit.
5. Station Heating System for Recharging Vehicle HS Unit.

Figures and Tables:

Figure B-1 Heat Sink Unit Operating Time

Figure B-2 Heat Sink Unit Schematic

Table B-1 Tube Heat Transfer Rates

1. SOLAR HEAT LOAD

The solar heat load was calculated for the guideway structure defined in Figure 4-1. These calculations show that the average guideway air temperature would go to 121°F with no air circulating in the system. At this temperature level, the guideway would dissipate the solar heat input at an equilibrium rate. Assuming full air flow (blower discharge temperature 131°F), the equilibrium average temperature was calculated to be 127°F. Comparing these equilibrium guideway air temperatures with those calculated for no solar load conditions, it is clear that the solar load is very significant. With no solar load, the equilibrium average guideway air temperature with full air flow from the blower is only about 4° above the 96° DB reference hot day temperature. Reduction of the solar load by increasing the insulation and by double glazing and the use of solar reflective glass is possible, but is also costly. A very effective alternate is the ventilation of the guideway (when vehicle cooling is required) by either natural draft or by mechanical forced draft. Either method will reduce average guideway air temperatures from the 125° range to the 100° to 110° range. The major favorable impact derived from the reduction of average guideway air temperature on the vehicle air conditioning problem stems from the fact that thermal load (heat input) to the vehicle from the guideway air through which it moves is cut nearly in half by this strategy. The conclusion is obvious—since guideway ventilation requires little or no energy, ventilate the guideway for significant reduction in vehicle cooling load.

2. VEHICLE VENTILATION

Uniflo vehicles accommodating passenger loads up to 12 can be adequately ventilated by a ventilating air flow of 120 cfm. To maintain 80° DBT and 70° WBT (vehicle air temperature), the ventilating air flow must be cooled enough to compensate for the passenger heat load and the heat transferred to the vehicle from the guideway air through which it moves.

The passenger heat load (sensible) was estimated at 220 BTU/hour/passenger. The heat transferred from the guideway air into the vehicle is dependent upon the degree to which the vehicle is insulated. With guideway to vehicle temperature differential of 30°, a poorly insulated vehicle would absorb 6,700 BTU per hour, while a well insulated vehicle with double glazing absorbs only 2,700 BTU per hour. Taking a 12 passenger vehicle (with 12 passengers) well insulated, the total cooling load is 5,320 BTU per hour. This cooling load is accommodated by cooling the 120 cfm ventilating air flow to a 40°F WBT.

The heating load for a well insulated vehicle with only 1 passenger (heating load drops as occupancy increases) on the reference cold day is 3,880 BTU/hr. This heating load is accommodated by heating the 120 cfm ventilating air flow to 80°F DBT.

3. HEAT SINK UNIT

The Heat Sink Unit is a fin-tube heat exchanger charged with a heat storage medium. The unit is designed to have enough capacity to operate as a heat sink (or heat source) for 45 minutes with the heating and cooling loads defined in the preceding section. The unit will be recharged during the station dwell time by an industrial refrigeration system (or a heating system) built into the station. Figure B-1 shows how the 45 minute operating time is extended for various regeneration rates.

The mechanical design for the HS Unit vehicle mounted air conditioning system is shown on Figures 4-5, 4-6, and 4-7. Cold (or hot) air is forced through the HS Unit during the station dwell time to regenerate the unit. While the vehicle is in the loading berth with the vehicle-berth doors open, the vehicle is a direct extension of the station space which is heated or cooled by the building HVAC system.

The vehicle is ventilated while in transit by bleeding 120 SCFM from the levitation pad system. This source is positive and relatively constant, and results in a positive vehicle interior pressure which effectively prevents the warm or cold vehicle passageway air from leaking into the vehicle. Ventilating air from the vehicle is filtered as it is exhausted to prevent dirt and debris generated by the passengers in the vehicle from being discharged into the vehicle passageway system.

For this study it was assumed that the HS Unit is charged with water and that the unit is so designed that the water can be frozen or heated to 200°F without damage to the tube structure. As a heat sink, the unit operates on the heat of fusion which gives 144 BTU per pound of charge. As a heat source, the unit operates

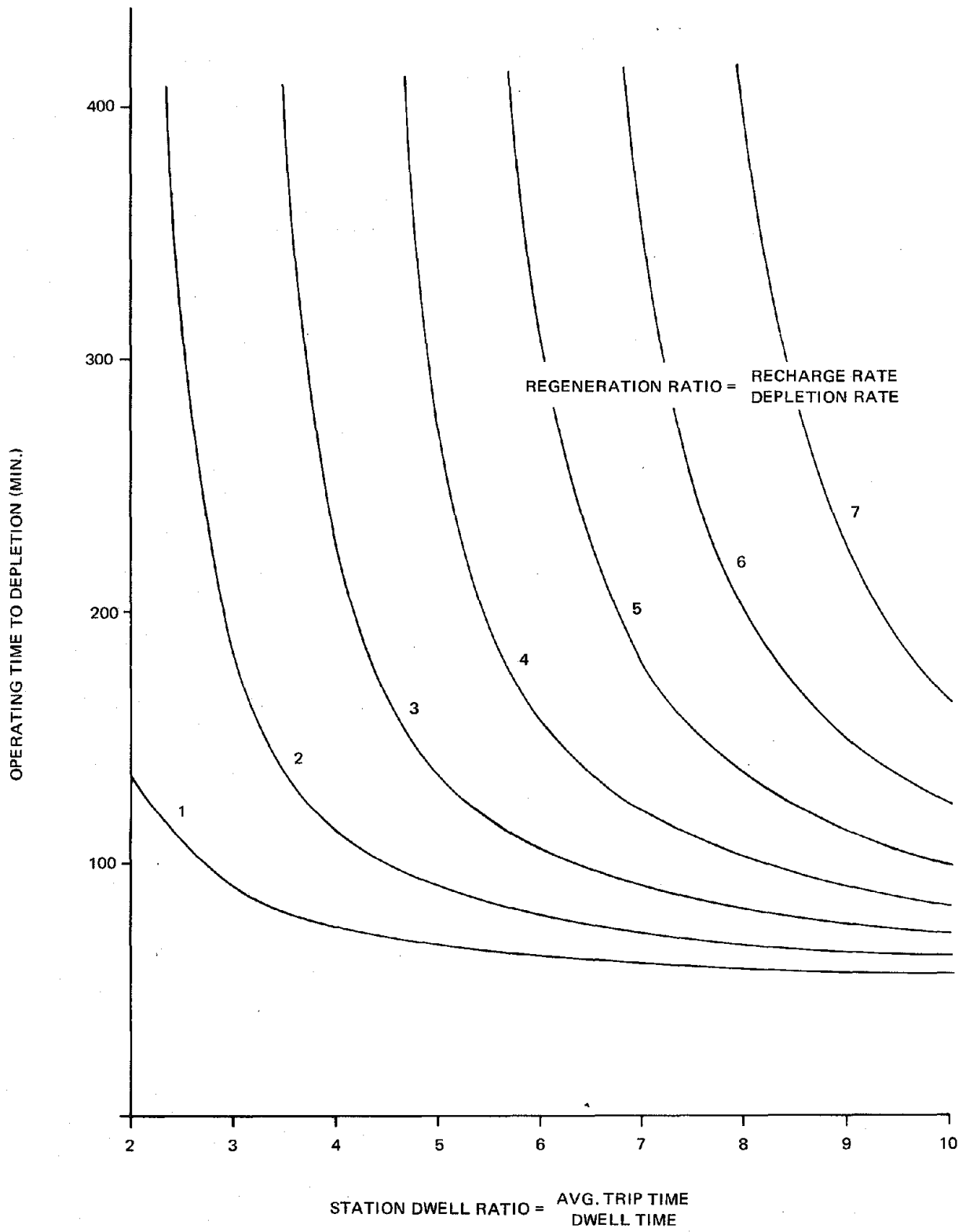
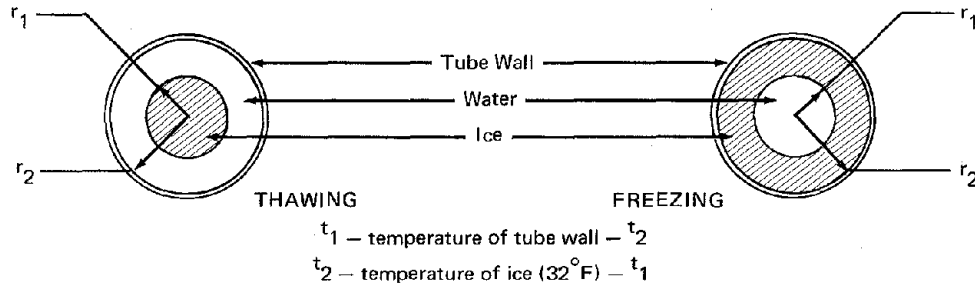

Figure B-1. Heat Sink Unit Operating Time as a Function of Regeneration Ratio and Station Dwell Ratio.

simply on the heat stored in the water at temperatures up to 200°F. (If the sealed tube structure is designed to withstand 10 psig, the fully charged temperature can be increased to 240°F, which would result in nearly a 50% increase in available stored heat.)

Table B-1 shows the rate at which heat can flow into a tube, assuming the contained water is frozen and progressively melted. As the ice melts, the flow rate decreases because water is a relatively poor heat conductor. The table also shows the rate at which heat can be extracted during the recharge cycle. The heat extraction rate is 4 times greater than the heat absorption rate because the thermal conductivity of ice is 4 times that of water. This is a desirable circumstance, as it tends to favor the recharge cycle as opposed to the draw down cycle, since vehicle trip times (draw down time) will typically be a multiple of the berth dwell time (recharge time).



HEAT TRANSFER RATE IN BTU/HR./LINEAL FT. OF TUBING

Radius Ratio r_1/r_2	1.01		1.1		1.5		2		3	
Percent Melted or Frozen	2		17		55		75		89	
$t_1 - t_2$	Thawing	Freezing	Thawing	Freezing	Thawing	Freezing	Thawing	Freezing	Thawing	Freezing
3	606	2,424	63.5	254	14.9	59.6	8.7	34.8	5.5	22.0
5	1,011	4,945	106	424	24.8	99.2	14.5	58.0	9.2	36.8
10	2,022	8,100	212	848	49.6	198.4	29.1	116.4	18.3	73.2
15	3,033	12,120	318	1,272	74.5	298.0	43.7	174.8	27.5	110.0
20	4,044	16,220	424	1,696	99.3	377.2	58.2	232.8	36.6	146.4

TABLE B-1 Tube Heat Transfer Rates

The HS Unit is diagrammed in Figure B-2. On the reference hot day with full solar load, the ventilating air from the pads has a 115° DB, 84° WB average temperature. The 120 SCFM ventilating air is to be cooled to 40° WB resulting in a cooling load of 17,800 BTU/hour. To provide 45 minutes of vehicle air conditioning, the HS Unit must have 13,400 BTU of useable capacity. Based on Trane Company refrigerant cooling coil capacity data, eight tube rows in a series will cool the ventilating air to the desired 40° WB temperature. As the HS Unit is discharged, the ice in the tubes melts progressively in the direction of ventilating air flow. With 53 rows of tubes in series and transverse to the ventilating air flow, the HS Unit cooling capacity will start to drop below the desired capacity when the melt has progressed through the first 47 rows, therefore, the HS Unit capacity must be based on containing in these rows enough ice to provide the design capacity of 13,400 BTU or $\frac{13,400}{144} = 93$ lb. of ice. The whole unit will then contain $\frac{53}{47} \times 93 = 103$ lb. of ice ($\frac{103}{57} = 1.81$ cu. ft.) This volume of ice can be contained in an US Unit in 2300 ft. of tubing having an I.D. of 0.379 in. (tube volume = 0.000785 cu. ft./foot.) With 15 tubes per inch in both directions, the HS unit will be 1.7 x 1.7 x 3.5 feet. (53 rows of tubes parallel to the air flow, 26 tubes per row.)

Data pertaining to heat transfer capacity for Trane refrigerant cooling coils which are quite similar to the subject HS Unit in terms of tube diameters and spacing is available relating capacity in BTU/ hour per sq. ft. of face area to face velocity and suction temperature. Extrapolating this data to the relatively low face velocity of 42 ft./min. ($\frac{120}{2.9}$), and the mean effective temperature difference of 28°F, a heat transfer capacity of 18,000

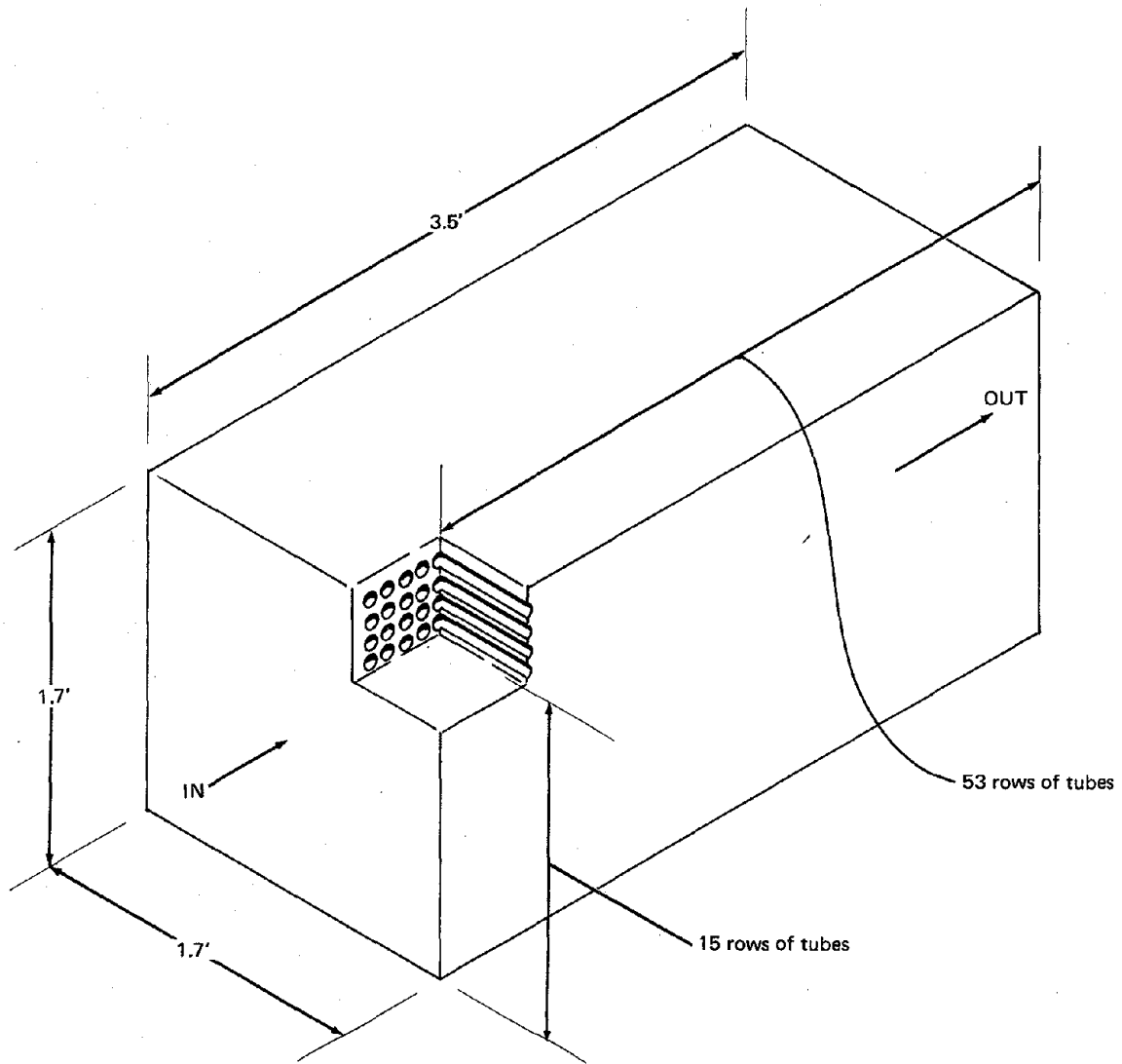

Unit has 2300 feet of 0.379" I.D. tubing which holds 103 pounds of ice
 Total Estimated Weight - 103 lb. charge + 223 lb. structure - 326 lb.

Figure B-2. Heat Sink Unit Schematic

BTU/hour is estimated, which matches the calculated cooling load of 17,800 BTU/hour.

The HS Unit is recharged in the station during the time when the vehicle is berthed. To maximize the charge rate, the cold air is blown through the unit at a face velocity of 1,000 fpm, which results in calculated recharge rates of:

BTU/Hour	Cooling Air Temp.	Charge Rate Factor	Installed Cost/Ton
86,000	0°F	4.8	\$1,200.00
115,000	-10°	6.5	1,300.00
151,000	-20°	8.5	1,400.00
183,000	-30°	10.3	1,500.00

The HS Unit is used as a heat source when vehicle heating is required. The sealed in water in the tube system can be heated to 200° without developing significant internal pressures in the tubes. The vehicle heating load, when occupied by one passenger is 3,880 BTU/hour at a vehicle interior temperature of 50°F DB. This vehicle temperature can be maintained by heating the 120 SCFM ventilating air flow to 80°F. On the reference cold day the ventilating air arrives at the vehicle at a temperature of 3°F. This air must be heated to 80°F which requires 11,350 BTU/hour. The HS Unit will, when fully charged, heat all of the air passing through it to 200°F, therefor, to heat the 120 SCFM ventilating air to 80°F only 38.5% or 46 CFM is passed through the unit. As the charge is depleted and the average temperature of the water in the heat exchanger approaches 80°F all of the ventilating air is circulated through the HS Unit.

The heat capacity, in terms of stored, available BTU in the HS Unit, is 11,300 BTU [103 lb. (200° - 90°)]. Thus the stored heating capacity in terms of vehicle operational time on the reference cold day, is 1.0 hour ($\frac{11,300}{11,350}$) which is somewhat greater than the designed 0.75 hour when operating in the cooling mode on the reference hot day.

4. STATION REFRIGERATION SYSTEM FOR RECHARGING VEHICLE HS UNIT

The HS Unit must be recharged during the time that the vehicle is in the station for off-loading and loading. The station refrigeration capacity (SRC) can be calculated from the following expression:

$$\text{SRC (tons)} = \frac{[\text{Vehicle Refrigeration Load (BTU/hr.)}] [\text{Charge Rate Factor}] [\text{No. of Berth}] \text{Occupancy Factor}}{12,000}$$

Where: Vehicle Refrigeration Load - 17,800 BTU/hr.

$$\text{Charge Rate Factor} = \frac{\text{Charge Rate (BTU/hr.)}}{\text{Vehicle Refrigeration Load (BTU/hr.)}}$$

$$\text{Occupancy Factor} = 0.75$$

Then SRC (tons)/berth = (1.11) (Charge Rate Factor) in tons

The occupancy factor reflects the fact that a berth is not occupied continuously since time must be provided in each loading cycle for vehicle movement in and out of the berth. The installed cost per ton is dependent upon the Charge Rate Factor. As this factor is increased it is necessary to resort to lower cooling air temperatures which increases the cost/ton of the refrigeration system. The following table shows the effect of increasing the charge rate factor on the installed cost per ton of refrigeration capacity:

STATION REFRIGERATION SYSTEM DATA

Charge Rate Factors	Cost/Ton	Tons/Berth	Cost/Berth
5	\$1,200.00	5.6	\$ 6,700.00
7	1,300.00	7.8	10,100.00
9	1,400.00	10.0	14,000.00
10	1,500.00	11.1	16,600.00

The energy cost per berth per hour with a charge rate factor of 5 is estimated at \$.11 when operating at peak load.

5. STATION HEATING SYSTEM FOR RECHARGING VEHICLE HS UNIT

During the heating season, the HS Unit must be charged to provide a heat source for warming the vehicle ventilating air. The station heating capacity (SHC) can be calculated from the following expression:

$$\text{SHC (BTU/HOUR)} = [\text{Vehicle Heating Load (BTU/HR.)}] [\text{Charge Rate Factor}] [\text{No. of Berths}] [\text{Occupancy Factor}]$$

Where Vehicle Heating Load = 11,350 BTU/HR.

$$\text{Charge Rate Factor} = \frac{\text{Charge Rate (BTU/HR.)}}{\text{Vehicle Heating Load (BTU/HR.)}}$$

$$\text{Occupancy Factor} = 0.75$$

Then SHC (BTU/HR./BERTH) = [8,500] [Charge Rate Factor (BTU/HR.)]

The following table shows the effect of increasing the charge rate factor on the heater capacity and capital cost:

STATION HEATING SYSTEM DATA

Charge Rate Factor	BTU/HR/BERTH	Cost/Berth
5	42,500	\$500
7	59,500	550
9	76,500	600
10	85,000	650

The energy cost per berth per hour with a charge rate factor of 5 is estimated at \$.08 when operating at peak load.

