

REPORT NO. DOT-TSC-RSPA-79-2

A STUDY OF TERRESTRIAL RADIO DETERMINATION  
Applications and Technology

J.E. Ward  
M.E. Connelly  
A.K. Tetewsky

ELECTRONIC SYSTEMS LABORATORY  
MASSACHUSETTS INSTITUTE OF TECHNOLOGY  
Cambridge MA 02139



FEBRUARY 1979  
FINAL REPORT

DOCUMENT IS AVAILABLE TO THE PUBLIC  
THROUGH THE NATIONAL TECHNICAL  
INFORMATION SERVICE, SPRINGFIELD,  
VIRGINIA 22161

Prepared for  
U.S. DEPARTMENT OF TRANSPORTATION  
RESEARCH AND SPECIAL PROGRAMS ADMINISTRATION  
Office of Transportation Programs Bureau  
Washington DC 20590

NOTICE

This document is disseminated under the sponsorship of the Department of Transportation in the interest of information exchange. The United States Government assumes no liability for its contents or use thereof. The report reflects the view of the authors, who are responsible for the facts and accuracy of the data presented herein, and it does not necessarily represent the official view or policy of the government. This is particularly true with respect to the choice of any one TRD system at the present time.

NOTICE

The United States Government does not endorse products or manufacturers. Trade or manufacturers' names appear herein solely because they are considered essential to the object of this report.

Technical Report Documentation Page

1. Report No. DOT-TSC-RSPA-79-2	2. Government Accession No.	3. Recipient's Catalog No.	
4. Title and Subtitle A STUDY OF TERRESTRIAL RADIO DETERMINATION-- Applications and Technology		5. Report Date February 1979	6. Performing Organization Code
7. Author/s) J.E. Ward, M.E. Connelly, A.K. Tetewsky	8. Performing Organization Report No. DOT-TSC-RSPA-79-2		
9. Performing Organization Name and Address Electronic Systems Laboratory* Massachusetts Institute of Technology Cambridge MA 02139		10. Work Unit No. (TRAIS) OS960/R9523	11. Contract or Grant No. DOT/TSC-1274
12. Sponsoring Agency Name and Address U.S. Department of Transportation Research and Special Programs Administration Office of Transportation Programs Bureau Washington DC 20590		13. Type of Report and Period Covered Final Report Sep. 1976-Sep. 1977	
15. Supplementary Notes *Under Contract To: U.S. Department of Transportation Research and Special Programs Administration Transportation Systems Center Cambridge MA 02142			
<p>This report describes the results of a study of terrestrial radio determination (TRD) applications and technology. Considerable emphasis has been placed on automatic automotive vehicle location or monitoring (AVL or AVM) systems because almost all of the system designs, tests, and operational installations over the past decade have been in these areas. Land vehicle applications considered include law enforcement, taxicabs, public transportation, emergency services, and trucking.</p> <p>The four basic TRD technologies -- hyperbolic, multilateration, proximity, and dead reckoning -- are discussed and compared. Particular points of comparison are accuracy, coverage area, measurement rates, communication requirements, vehicular capacity, and fixed installations required. Also discussed are the pros and cons of centralized vs. decentralized systems, multi-user systems, the advantages of hybridization among TRD technologies to achieve system goals in particular applications, and the results of Loran-C measurements made in Boston as part of the study.</p> <p>The subject of TRD communication has received particular attention, since in many TRD systems, communications is already the limiting factor in system capacity. The problems of digital communications on land-mobile radio channels are presented, existing TRD communications are described and compared, and some suggestions for improvement, perhaps involving development and FCC authorization of new types of radio channels, are presented.</p> <p>Conclusions are presented on the potential benefits of TRD, and on the actions that U.S. Government agencies might take in regard to fostering TRD developments and applications.</p>			
17. Key Words TRD, monitoring, accuracy, hybridization		18. Distribution Statement DOCUMENT IS AVAILABLE TO THE PUBLIC THROUGH THE NATIONAL TECHNICAL INFORMATION SERVICE, SPRINGFIELD, VIRGINIA 22161	
19. Security Classif. (of this report) Unclassified	20. Security Classif. (of this page) Unclassified	21. No. of Pages 206	22. Price



## PREFACE

The authors wish to thank the many people and organizations that have taken time to meet with us during the course of this study, or to spend time on the telephone answering difficult questions. Visits are detailed in the Appendix, but the numerous people talked to by telephone have not been specifically identified.

Thanks are also due to Mr. Constantine Photopoulos for the Loran-C measurements reported in Section 3.3 conducted as a Bachelor of Science thesis, and to the International Navigation Corporation for loaning the receiver used.

Finally, thanks are due to Dr. Ralph Kodis, Mr. Harold Stein, and Mr. Edward Farr of the DOT/Transportation Systems Center for their direction of the work, and their understanding as delays occurred in the completion and submission of this final report.

# METRIC CONVERSION FACTORS

Symbol	When You Know	Multiply by	To Find	Symbol
		<b>LENGTH</b>		
mm	millimeters	0.04	inches	in
cm	centimeters	0.4	inches	in
m	meters	3.3	feet	ft
m	meters	1.1	yards	yd
km	kilometers	0.6	miles	mi
		<b>AREA</b>		
cm <sup>2</sup>	square centimeters	0.16	square inches	in <sup>2</sup>
m <sup>2</sup>	square meters	1.2	square yards	yd <sup>2</sup>
km <sup>2</sup>	square kilometers	0.4	square miles	mi <sup>2</sup>
ha	hectares (10,000 m <sup>2</sup> )	2.5	acres	ac
		<b>MASS (weight)</b>		
g	grams	0.005	ounces	oz
kg	kilograms	2.2	pounds	lb
t	tonnes (1000 kg)	1.1	short tons	
		<b>VOLUME</b>		
ml	milliliters	0.03	fluid ounces	fl oz
l	liters	2.1	pints	pt
l	liters	1.06	quarts	qt
l	liters	0.26	gallons	gal
m <sup>3</sup>	cubic meters	36	cubic feet	ft <sup>3</sup>
m <sup>3</sup>	cubic meters	1.3	cubic yards	yd <sup>3</sup>

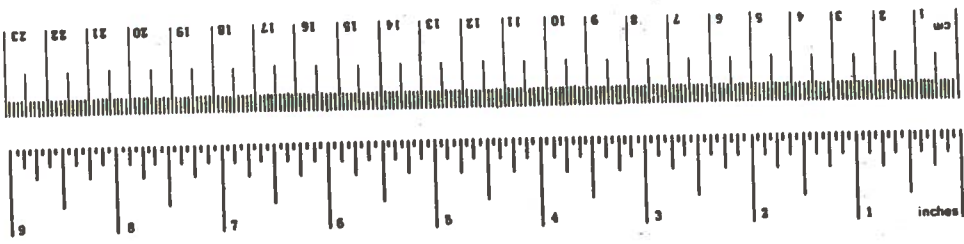

Symbol	When You Know	Multiply by	To Find	Symbol
		<b>LENGTH</b>		
in	inches	2.5	centimeters	cm
ft	feet	30	centimeters	cm
yd	yards	0.9	meters	m
mi	miles	1.6	kilometers	km
		<b>AREA</b>		
in <sup>2</sup>	square inches	6.5	square centimeters	cm <sup>2</sup>
ft <sup>2</sup>	square feet	0.09	square meters	m <sup>2</sup>
yd <sup>2</sup>	square yards	0.8	square meters	m <sup>2</sup>
mi <sup>2</sup>	square miles	2.5	square kilometers	km <sup>2</sup>
ac	acres	0.4	hectares	ha
		<b>MASS (weight)</b>		
oz	ounces	28	grams	g
lb	pounds	0.45	kilograms	kg
	short tons (2000 lb)	0.9	tonnes	t
		<b>VOLUME</b>		
tblsp	tablespoons	5	milliliters	ml
fl oz	fluid ounces	30	milliliters	ml
c	cup	0.24	liters	l
pt	pint	0.47	liters	l
qt	quart	0.95	liters	l
gal	gallon	3.8	liters	l
ft <sup>3</sup>	cubic feet	0.03	cubic meters	m <sup>3</sup>
yd <sup>3</sup>	cubic yards	0.76	cubic meters	m <sup>3</sup>
		<b>TEMPERATURE (exact)</b>		
°F	Fahrenheit temperature	5/9 (after subtracting 32)	Celsius temperature	°C

### TEMPERATURE (exact)

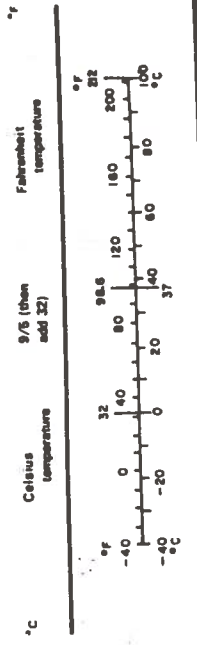

## CONTENTS

	<u>Page</u>
1. INTRODUCTION	1
2. POTENTIAL TRD APPLICATIONS, REQUIREMENTS, AND BENEFITS	3
2.1 Police Vehicle Dispatching	3
1) Response Time	3
2) Apprehension Rates	3
3) Response Time Data on CAD and AVL Systems	7
4) Simulation Study of the Effect of AVL on Travel Time	11
5) System Integration and Push-Button Dispatching	12
a) Incident Detection and Reporting to the Police	14
b) Complaint Clerk Functions	14
c) Dispatcher Functions	15
d) Travel Time	19
6) Reducing Travel Time	21
a) Preemption	21
b) One-Man Cars	23
c) Dispatch Strategy	23
7) Benefits of Reduced Response Time	23
8) AVL Requirements for Law Enforcement	29
a) AVL Accuracy	29
b) Update Rates	34
c) AVL Coverage	37
d) AVL Cost Requirements	39
2.2 Taxicab Dispatching and Security	40
2.3 Fixed Route and Dial-A-Ride Bus Control	47
1) Fixed-Route Headway Regulation	47
2) Dial-A-Ride Bus Control	57
2.4 Emergency Medical Services	70
2.5 Aircraft Movement on an Airport Surface	73

CONTENTS (cont'd)

	<u>Page</u>
2.6 Truck Dispatching and Security	76
3. LOCATION TECHNOLOGY	84
3.1 TRD System Considerations	85
1) System Choice	85
2) Centralization vs. De-Centralization	86
3) Basic TRD Categories	88
a) Hyperbolic Navigation Systems	88
b) Multilateration Location Systems	89
c) Proximity Location Systems	90
d) Dead-Reckoning Systems	92
4) Hybrid Systems	94
3.2 The 1977 Philadelphia Tests	98
1) Introduction	98
2) The Los Angeles Accuracy Requirements	99
3) The Tested Systems	99
4) Position Location Performance	101
3.3 Loran-C Experiments by M.I.T.	102
3.4 General Observations on Location Technology	110
1) Accuracy	110
2) Coverage	110
3) Capacity	111
4. COMMUNICATION TECHNOLOGY	115
4.1 Introduction	115
4.2 Mobile Digital Technology	115
1) Regulatory Issues	115
2) Equipment in Being	116
3) The Land-Mobile Channel	117
4) Digital Modulation Techniques and Problems	119
5) Digital Message Time	122
6) Non-Voice-Channel Communications	124



CONTENTS (Cont'd)

	<u>Page</u>
4.3 Communications Disciplines	125
1) Time-Slot Systems	125
2) Interrogate-and-Respond Systems	127
3) Random-Access Systems	130
4) Error Control	132
4.4 Typical TRD Communications Systems	134
1) Boeing FLAIR System (Dead-Reckoning TRD)	134
2) Teledyne System (Loran-C TRD)	137
3) Hoffman System (Proximity TRD)	138
4) Hazeltine System (Pulse Multilateration TRD)	140
5) Communications Systems Comparisons	140
4.5 Possibilities for Improved Digital Communication Links	142
5. CONCLUSIONS AND RECOMMENDATIONS	148
5.1 Conclusions	148
5.2 Recommendations Regarding Application Areas	149
1) Police, Fire and Medical Services	149
2) Public Transportation	153
3) Truck Dispatching and Security	158
4) Disaster Relief and Civil Defense	159
5) Aircraft Surface Navigation	160
6) Other Aircraft and Marine Applications	160
5.3 Recommendations Regarding Technology Improvement	161
1) Loran-C	161
2) TRD Communications	161
APPENDIX A Visits and Other Contacts	163
APPENDIX B Comments on Non-Terrestrial Applications that might Share TRD Location Capabilities and Technology	180
APPENDIX C References	189
APPENDIX D Report of New Technology	195

FIGURES

	<u>Page</u>
1. Percent of Arrests in Relation to Overall Response Time	4
2. Arrest Delay Time	6
3. Receipt of Call-To-Dispatch Times - All Events LOCATES Systems Used Versus Not Used	8
4. Dispatch-To-Arrival Times - All Events LOCATES System Used Versus Not Used	9
5. Total Response Times - All Events LOCATES System Used Versus Not Used	10
6. Relationship Between Patrol Car Travel Time and Utilization Factor (9-Sector Hypothetical Command)	13
7. Huntington Beach Car Status Display	17
8. Huntington Beach Incident Display	18
9. Typical Map Elements of the FLAIR Display	20
10. Average Travel Time as a Function of Sector Area and Effective Speed	22
11. Suburban Scenario, Automatic Vehicle Location System Benefits (Montclair, CA)	25
12. Urban Scenario, Automatic Vehicle Location System Benefits (New Orleans, LA)	26
13. Metropolitan Scenario, Automatic Vehicle Location System Benefits (New York City Precinct 103)	27
14. Average Extra Distance Traveled Relative to a Perfect AVL System	31
15. Comparison of C.P.E. Radii with the Street Map of Downtown Boston	33
16. AVL System Accuracy Versus Update Rate	36
17. Placement of Wayside Emitters in Montclair	38
18. Capital Investment Versus Number of Cars	41
19. Location of Major Transportation Terminals and Taxi-Cab Stands within Boston Proper	44

FIGURES (cont'd)

	<u>Page</u>
20. Typical Transit and Highway Diversion Curves, Rapid Transit	49
21. Transit Equipment Requirements, Cleveland, 1966	51
22. Relationships Among Demand Rate, Vehicles, and Area (Many-to-Many DAR, Mean Level of Service 2.5)	66
23. Relationships between Number of Vehicles and Level of Service (Many-to-Many DAR, 25 Demands/sq. mile/hr.)	67
24. Taxiway Network -- Kennedy Airport	75
25. Loran-C Readings taken May 6, 1977 at Fixed Location (MIT/ESL)	107
26. Plot of Vessel Trajectory Around Known Buoy Locations (based on Loran-C TD's), St. Mary's River Tests 1977	114
27. Typical Fading Envelope Measured at a Carrier Frequency of 850 MHz	118
28. Digital Data Transmission via FM Voice Radios	121
29. Time Components of a Mobile-to-Base Transmission	121
30. Comparison of Standard Audio Low-Pass Filter and New Emission-Attenuation-Based Rolloff for F3Y Digital Modulation	145

TABLES

	<u>Page</u>
1. Car Locator Resolution and Dispatch Error Characteristics (9-Sector Hypothetical Command; Utilization Rate $\rho = 0.0$ )	29
2. Weekday Person Trips in Eastern Massachusetts, Regional Planning Project (1964 Measurements)	61
3. Comparison of Position Location Accuracy Results for 1977 Philadelphia Tests for Four Systems	103
4. Changes in Loran-C Readings at M.I.T. over Ten Days	106
5. TRD Communications Systems Comparisons	141

## 1. INTRODUCTION

The objective of this study program was to evaluate the potential applications of terrestrial radio determination (TRD) systems and to relate the requirements of such applications to the numerous specific techniques available for implementing TRD. The primary goal was to assist the Department of Transportation in formulating a rational, long-term policy in this area with respect to research and development programs, the support of demonstration systems, the establishment of national standards, and regulatory matters. A particular aspect was to investigate carefully the possibility of satisfying the requirements of multiple TRD applications with a common system.

In the conduct of the study, an extensive literature search was made and the large number of applicable reports located were carefully reviewed, the principal operational TRD systems were visited, and contacts were made with potential users and suppliers of TRD and mobile digital communication equipment. A number of applications have been identified in which an automatic vehicle locating capability appears to be cost effective, including police dispatching, fixed route and dial-a-ride bus systems, taxi dispatching, aircraft navigation on an airport surface, and truck dispatching and security. These applications are fully discussed in Section 2. With a TRD system in place, numerous secondary applications might also become economically feasible, but it has been assumed that the initial TRD installations must be justified by the benefits received by the primary users listed above.

TRD technology has also been reviewed and analyzed as it applies to various applications. Under most conditions, any of the basic TRD techniques now available appear to be capable of providing adequate accuracy for the AVM and AVL applications discussed in Section 2. Extreme accuracy requirements or difficult operating environments can, in most cases, be handled by a combination of techniques. TRD technology is discussed in detail in Section 3.

It should be noted that TRD techniques will normally be employed as part of a computer-based command and control system and that the integrated functioning of the overall system must be considered in selecting the TRD component and in evaluating its cost effectiveness. In particular, we have found that providing adequate digital data communication capacity and coverage to service multiple users will probably be the limiting factor in the performance of most systems, consequently a substantial effort has been devoted to analyzing the communication requirements of each of the primary applications. In Section 4, the limitations of current mobile data links are identified, and several methods for correcting such deficiencies are suggested.

Conclusions and recommendations are given in Section 5, and the Appendix describes the visits made and other contacts.

## 2. POTENTIAL TRD APPLICATIONS, REQUIREMENTS, AND BENEFITS

Several comprehensive reviews of potential TRD applications have already been published, e.g., by the Orange County General Services Agency (Reference 4), the Institute of Public Administration and Teknekron (Reference 5), the Mitre Corporation (Reference 6), and the Jet Propulsion Laboratory (Reference 7). We will concentrate in this section on those applications which we believe have the greatest potential payoff, i.e., police dispatching, bus transit systems, taxi dispatching, aircraft navigation on an airport surface, emergency services, and truck scheduling and security.

### 2.1 Police Vehicle Dispatching

1) Response Time. The principal benefits derived from a knowledge of vehicle locations in police work are reduced response time, greater officer safety, reduced radio channel congestion, and a reduced requirement for supervisory patrols. The most important of these is reduced response time since it results in a higher apprehension rate, it sometimes prevents a non-criminal incident (e.g., family argument) from escalating into a criminal incident (assault/murder), and it increases a victim's chances of survival if emergency medical service is required. Moreover, a community's opinion of its own police department is greatly enhanced by prompt responses to complaints. Conversely, the reputation suffers when the police are slow in arriving, especially on priority calls. Although it is difficult to prove, disrespect for the police probably encourages a higher level of criminal activity than would otherwise be the case. The recent sharp rise in crime in Montreal during a police "slow-down" indicates that criminals are not unmindful of a department's current state of effectiveness.

2) Apprehension Rates. Several attempts have been made to quantify the value of reduced response time (References 8, 11, 12, 15), but, in our opinion, the data available is still insufficient to support a firm conclusion.

Data collected by Isaacs (Reference 11) in Los Angeles are shown in Figure 1. Any point on the curve represents the percentage of arrests in

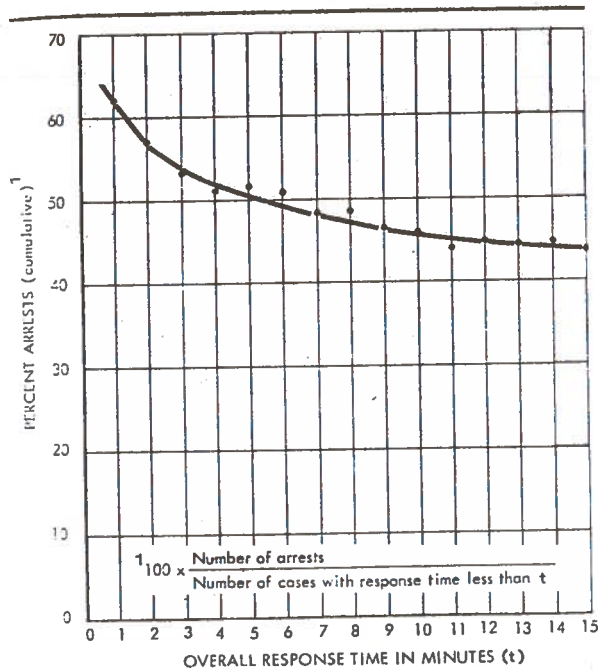

Figure 1 Percent of Arrests in Relation to Overall Response Time (Code Six Responses Only)\*

\*A code six message is one given by radio by a field officer when he arrives at the scene of a call.



all cases with response times less than the specified value. This plot, however, is based on only 70 criminal incidents for which both patrol and communications center response times happened to be available. The actual arrest rate on calls in Los Angeles (14%) is much lower than the plot would indicate. The trend, lower response time producing a higher arrest rate, is as expected. Of the 4376 calls for service involving a possible crime analyzed by Isaacs, only 1614 (37%) actually resulted in a crime report. Of these crimes, 227 (14%) were cleared by an arrest and 95 (6%) were cleared by other means, i.e., a total of just 20% of the crimes reported were cleared. Figure 1 shows 40% to 60% of the crimes in the sample being cleared by an arrest. This implies that the sample included a disproportionate number of crimes against persons, for which the apprehension rate is much higher than for crimes against property.

On the 4,376 calls examined by Isaacs, the communications center average delay was 5.17 minutes (std. deviation 9.09 minutes), but on a subset of emergency calls the delay averaged only 2.11 minutes (std. deviation 3.90 minutes). On a small sample of 265 calls, the patrol response time averaged 5.23 minutes (std. deviation 7.67 minutes). Of these, 160 calls were ranked as emergencies and for this subset, the average patrol response time was 3.81 minutes (std. deviation 5.29 minutes). If the data on the 265 calls is taken as being typical of all calls, then the average overall response time in possible crime incidents is 10.4 minutes (std. deviation 11.9 minutes). For incidents in the emergency category, the average overall response time is 5.92 minutes (std. deviation 6.57 minutes).

Some arrests are not the result of a call to the police followed by the dispatching of a patrol car to an incident. Often the officer in the field observes criminal or suspicious activity himself, chances upon a wanted person or stolen vehicle, or is notified directly by a citizen that a crime has been committed. When such cases are added to the radio call cases, Isaac's sample of crime reports increases to 1905 of which 482 (25%) were cleared, 336 by arrest and 146 by other means. Of the arrests, 304 (90%) were made by patrols and 32 (10%) by detectives. About 25% of the patrol arrests, however, were people previously identified in a detective followup. As shown in Figure 2, almost half of all arrests

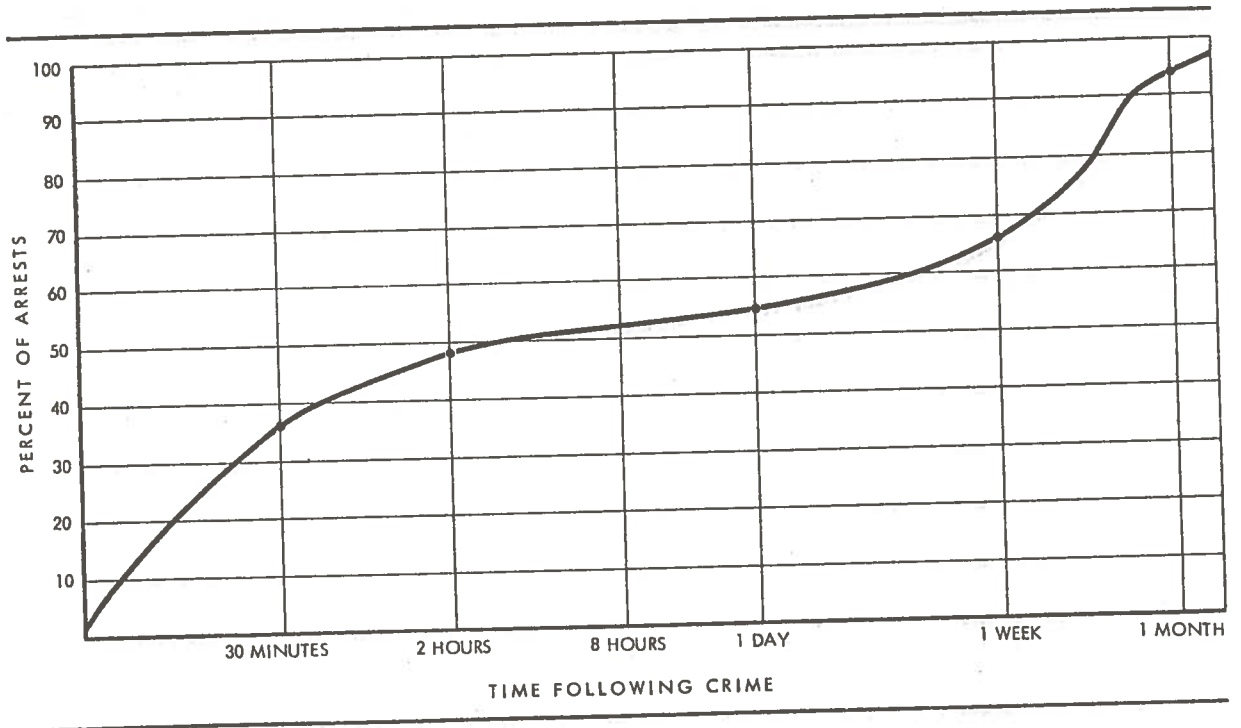

Figure 2 Arrest Delay Time

are made within 2 hours of the crime, and 223 of the 336 arrests (66%) were at the scene of the crime or in the vicinity. Significantly, 91 arrests resulted from an officer observing suspicious activity directly. The clearance of cases with unnamed suspects is low (181 out of 1556 cases, or 12%) and most of these resulted from on-scene arrests. About the only effective strategy for this important category of crime is to get to the incident quickly and to increase the amount of preventive patrolling. Once the crime is committed and the criminal has left the vicinity, there is very little chance of apprehension.

3) Response Time Data on CAD and AVL Systems. Since a number of factors contribute to the overall response time, the emphasis should be on an integrated system design which attempts to reduce all of the delay components. The introduction of a single improvement, such as AVL or computer-aided dispatching (CAD), taken alone, is often not sufficient to produce a significant improvement in apprehension rates. The implementation of the Boston CAD system, for example, has only reduced the average overall response time to priority calls from 9 minutes to 8 minutes. In St. Louis in 1975, the overall response time in District 3, where AVL (FLAIR) - equipped vehicles were operating, was 8.54 minutes. In the previous year, without FLAIR, the response time in that District had been 9.02 minutes (Reference 9).

In smaller cities, dispatching innovations have produced more significant benefits. The Huntington Beach CAD and street address data base has reduced the response time for emergencies to 4.5 minutes (Reference 1). Nearby Santa Ana is similar in population and area to Huntington Beach, but it has no computer aided dispatching. The emergency response time there is 6.4 minutes. In Montclair, California, the installation of a signpost AVL system and pushbutton status reporting reduced both the dispatch delays and the vehicle transit times as shown in Figures 3, 4, and 5. Montclair is a compact city (population 27,000; area 5.2 square miles) with an easily traversed street grid. With AVL, 83% of the total response

MONTCLAIR POLICE DEPARTMENT

(ALL EVENTS)

SUMMARY OF DISPATCHER RESPONSE TIMES

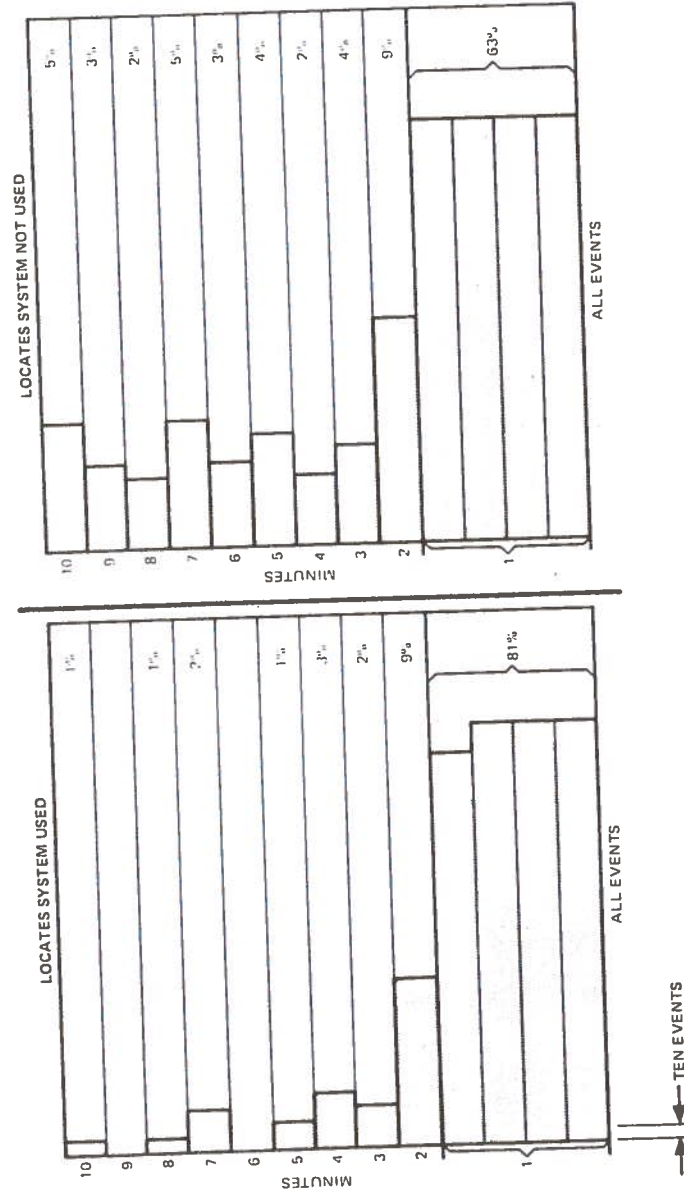

Figure 3. Receipt Of Call-To-Dispatch Times - All Events  
LOCATES System Used Versus Not Used

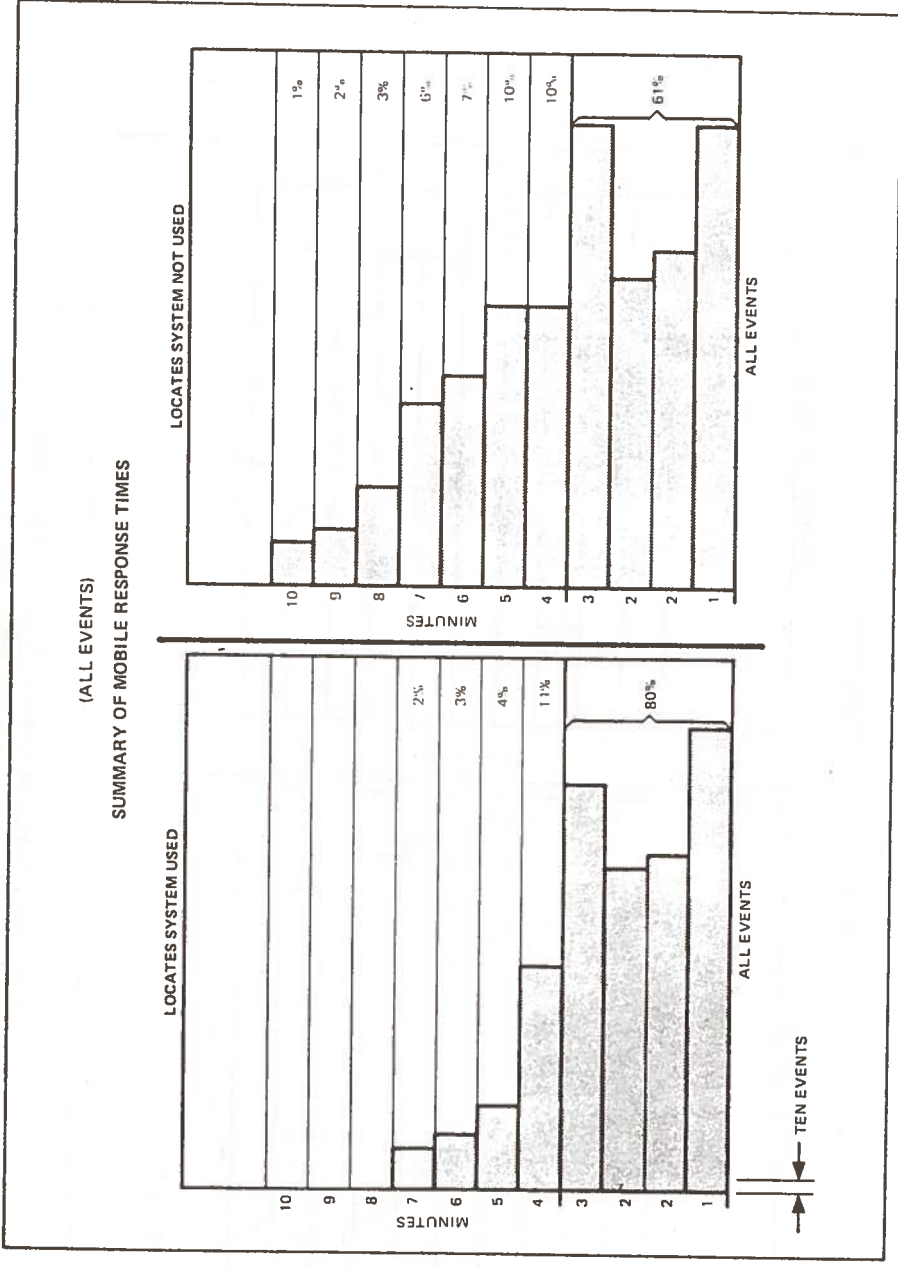

Figure 4. Dispatch-To-Arrival Times - All Events  
LOCATES System Used Versus Not Used

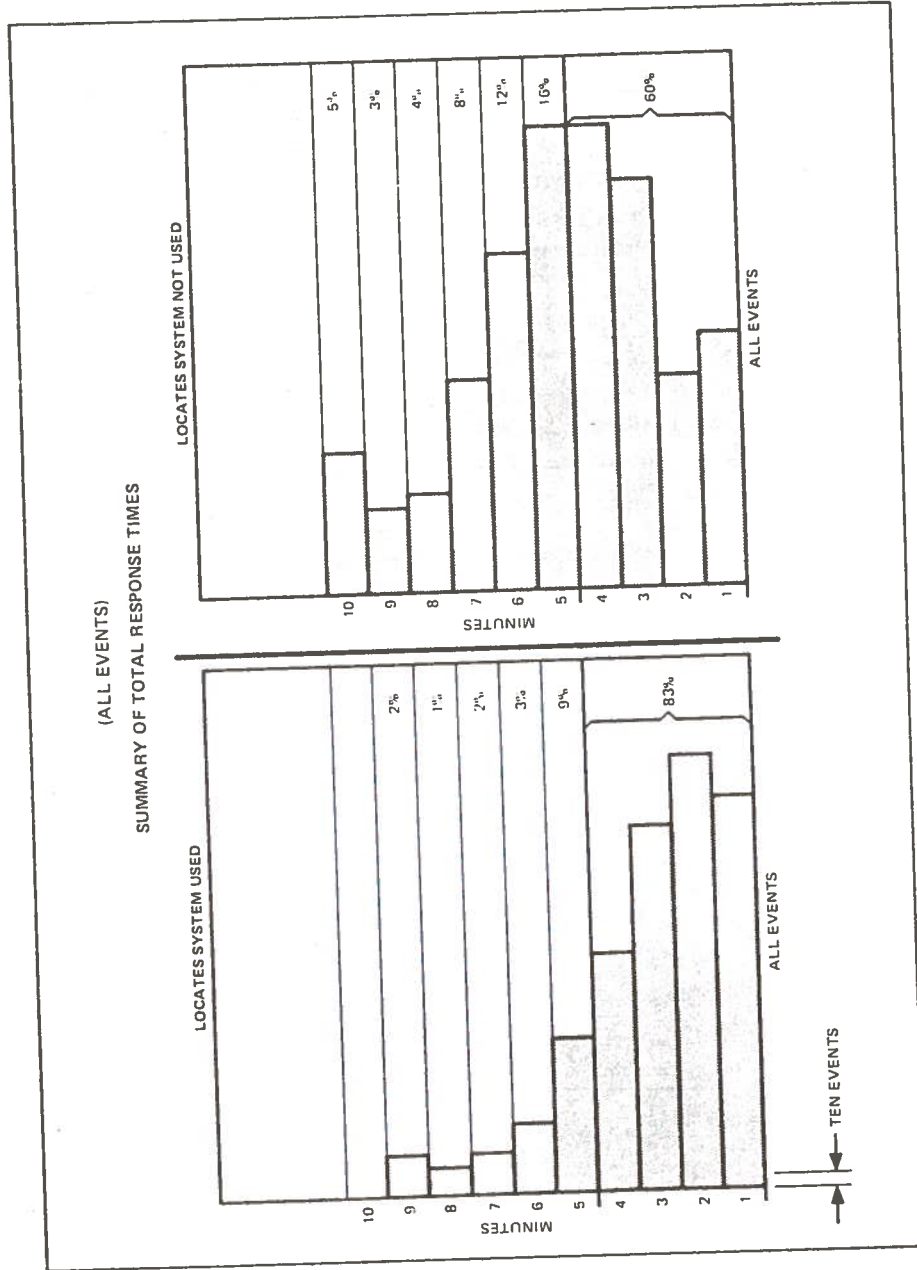

Figure 5. Total Response Times - All Events  
LOCATES System Used Versus Not Used

times were 4 minutes or less (Reference 10). The average travel time with LOCATES was 1.9 minutes, whereas without LOCATES, it was 2.9 minutes (Reference 15).

4) Simulation Study of the Effect of AVL on Travel Time. In a classic simulation study (Reference 13), Larson compared the average travel time obtained by two dispatching strategies in a hypothetical precinct composed of 9 one-mile squares:

- a) Strict center-of-mass dispatching, i.e., the exact positions of the 9 patrol vehicles and of the incidents were not considered in selecting the nearest unit. Each vehicle on preventive patrol was assumed to be at the center of mass of its assigned patrol sector and each incident at the center of mass of its sector. If just completing an assignment, a vehicle was assumed to be at the center of mass of the sector in which the incident occurred.
- b) Nearest car dispatching with AVL supplying perfect location information on each car. Cars completing service were assigned to the nearest waiting call if a queue existed.

The geographic and functional model used by Larson is rather specific, but it indicates roughly the reductions in response time that can be achieved by AVL techniques. Cities are usually sub-divided into supervisory units called precincts or districts, which in turn are sub-divided into patrol sectors. A single dispatcher may handle the patrols of several precincts but only rarely is a car from one precinct assigned to an incident in another precinct. The basic functional unit and queue, therefore, is at the precinct level. In New York City, there are 77 precincts and over 700 patrol sectors, i.e., about 9 patrol sectors per precinct. Larson's 9-sector model, therefore, corresponds functionally to a typical New York City precinct, although a one square mile sector is somewhat large for an urban police department. The 79 patrol sectors in Boston, for example, range from 0.15 to 1.6 square miles in area. The average size is 0.57 square miles. On the other hand, Huntington Beach has an area of 26.5 square miles divided into 12 beats, i.e., 2.2 square miles per beat, whereas Montclair averages 1 square mile for each of its 5 beats.

Larson's simulation results, with and without the AVL capability, are shown in Figure 6. Utilization factor is the fraction of time that the patrol cars are on assignment. In the middle range of utilization factors (0.3 to 0.7) where police systems operate most of the time, the availability of vehicle locations reduces the average travel time by 0.5 to 1.0 minute. Under near-saturation conditions ( $\rho=0.95$ ), the simulated AVL system reduces travel time by 2.5 minutes, but most of this decrease is due to the strategy of reassigning cars to the nearest incident when a queue exists. Larson generalizes these results as follows, "In a command of typical size (for example, 9 sectors) the reduction in mean travel time caused by car position information is not particularly large (usually less than 20 percent, depending on the utilization factor)."

As the utilization factor increases, Larson's data also indicates that the fraction of assignments which are inter-sector increases almost in proportion. To illustrate this, at a utilization factor of 0.75 in the AVL simulation, the fraction of assignments out of a car's own sector, on the average, was exactly 0.75. With strict center of mass dispatching, the wrong (i.e., not the nearest) car was assigned to an incident 20% of the time at this utilization factor and each of these errors, on the average, increased the distance travelled by 0.4 miles (1.6 minutes at 15 mph).

5) System Integration and Push-Button Dispatching. Some analyses of AVL systems stop at this point and conclude that a mere 10-20% reduction in average travel time is, at best, a marginal justification for implementing such systems (References 9,14). The AVL, however, makes possible additional improvements in the dispatch process, which would produce much more significant benefits and could lead eventually to push-button dispatching. With an automatic telephone-address data base, computer-aided dispatching, and automatic vehicle location, we feel that the dispatch delay in emergency cases could be reduced to about 15 seconds. The total response time in such cases would be largely determined by



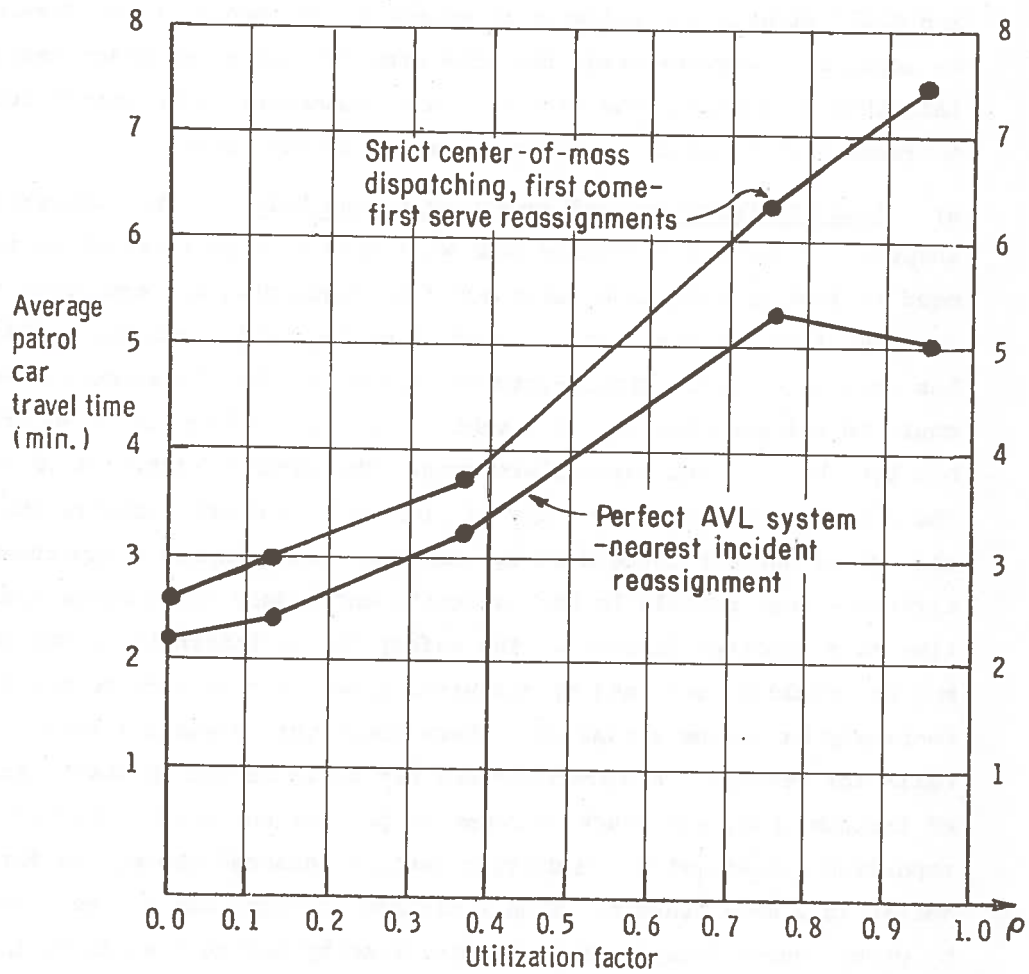

- Travel speed assumed to be 15 mph
- Approx. 900 calls for service were generated in each simulation run

Figure 6 Relationship between Patrol Car Travel Time and Utilization Factor (9-Sector Hypothetical Command)

the vehicle travel time, and this could also be reduced by more sophisticated dispatch strategies and force deployments made possible by AVL and CAD. Without any increase in manpower, it appears to be feasible to achieve an average total response time in police emergency cases of less than 3 minutes. The technical and procedural improvements necessary to reach this level of performance are discussed below:

a) Incident Detection and Reporting to the Police - The widespread adoption of the 911 emergency code will save time by eliminating the need to look up telephone numbers before requesting any emergency services (police, fire, medical, etc). Opening police call boxes for public use has been suggested. Victim-actuated alarms are highly effective and these could be relayed directly to a vehicle; burglar alarms are also effective, but they have a high false alarm rate. The obvious tactic of increasing the number of patrolmen on duty is limited by economic constraints, but the use of one-man instead of two-man cars would enable a department to circulate more patrols in the community and reduce the average travel time to a reported incident. The safety factor intrinsic in the two-man car could be retained by dispatching two or more cars to every potentially hazardous situation. These constitute a small fraction of all calls for service. A communications net could be set up which incorporated taxicab, bus, and truck drivers as part of the crime detection and reporting system, with the drivers getting enhanced protection for themselves as a side benefit. When a citizen contacts the police department by phone, queue delays should be minimized by having a sufficient number of incoming trunks and complaint clerks to handle peak loads. Larson (Reference 13) has observed saturated systems in which up to 40% of the calls incurred delays of 30 seconds or more. An automatic call distributor is required to assure that calls are handled on a first come - first served basis to minimize the possibility of a long wait.

b) Complaint Clerk Functions - According to Larson, the average time to gather and record information about a complaint (names, addresses, incident description, etc.) is 20 to 30 seconds, although some complaints

stretch out to 2 minutes or more. The precinct and patrol sector corresponding to the address must be looked up and the complaint slip transferred to a dispatcher. Using the old manual conveyor belts, the transfer operation alone took 5-10 seconds. In St. Louis, the clerk writes up the complaint on a polygraph and the information is copied simultaneously at a dispatch post. The complaint clerk also makes the critical decision of assigning a priority to the incident. Mistakes could be serious and, for that reason, St. Louis employs fully qualified police officers as complaint clerks. In computer aided dispatch systems (CAD), the clerk enters the information received directly into the computer via a keyboard, using an alphanumeric display to check the entries and correct mistakes. The computer automatically verifies the address, assigns a case number, and looks up the corresponding precinct and sector. When complete, the complaint information can be transferred without delay to the appropriate dispatcher's display queue. One additional improvement is possible in the complaint clerk's operation. An automatic telephone-address look up can be provided which makes the address of the phone from which the call originates available immediately. The Chicago Police Department now has this capability.

c) Dispatcher Functions - If the dispatcher has a queue of complaints waiting to be serviced or if there are no precinct vehicles available, an incoming complaint may not be acted upon immediately. Larson states that dispatcher saturation delays "vary from a few seconds to a few minutes, but they rarely exceed 10 minutes." In some cities, patrol force saturation (no cars available within the precinct) frequently causes delays of more than a hour. In servicing a complaint, the dispatcher selects a unit to assign (usually the sector patrol, if it is available) and verbally transmits the address and other pertinent information about the incident to the unit. Typically, the transmission lasts only 10 to 15 seconds, although sometimes lengthy descriptions must be passed on to the patrol and these are time consuming. If the sector car is not available, further delay is incurred trying to find the nearest available vehicle from another sector. Since patrols spend

a substantial fraction of the time out of their own sectors, keeping track of their movements and status, and trying to assign the nearest available car to a given event is a major part of the dispatcher's workload. Computer aided dispatching (CAD) reduces this workload to a degree.

The Huntington Beach CAD system may be taken as typical. It provides the dispatcher with two computer-generated displays:

Car Status Display (Figure 7) - Communications data and the status of all cars (available, enroute, at scene, investigate, to station and out of service) are listed along with the number of the case assigned to each busy car and the number of incidents in each beat which have not yet been serviced. Car status is updated automatically on the basis of status reports transmitted from the vehicles via their digital status entry units.

Incident Display (Figure 8) - The information entered by the complaint clerk on the case being processed is displayed along with the corresponding reporting district, fire box number, and beat number. The dispatcher enters the vehicle number of the unit he decides to assign to the case on his keyboard, whereupon the computer automatically transmits all the information in the complaint to the designated car, where a teleprinter produces a hard copy. Below the action area, the same display has a table of assigned, but unresolved cases, categorized by incident type, and a table of all unassigned incidents with abbreviated details on each. Any case can be transferred to the action area by the dispatcher by typing in the case number.

The implementation of an automatic vehicle location (AVL) system at the Huntington Beach facility gave the dispatchers the following additional assistance. A color TV monitor is provided with the location and status of all police vehicles superimposed on a street map of the city. Zoom capability enables the dispatcher to view areas down to a half mile square. When a case is placed in the active area of the

```

1 UNIT 3A2 REQUEST CAR STOP
2 EXCEPTION=314
3 UNIT 617S2 EMERGENCY 17A4 EMERGENCY UNIT 19A4 EMERGENCY
4 1 MESSAGES---UNIT 23S2 REQUEST CALL 123A2
5 UNIT ON RADIO= 2A2 19A2 214A3
6
7
8 AVAILABLE..... AT SCENE..... INVESTIGATE..... TO STA OUT...
9 2A3 13A2 ..... 5A2/039 ..... 2A1 108A2 ..... 6A1 9A4
10 2A2 14A3 ..... 7A3/043 ..... 3A4 117A3 ..... 7A4 17A1
11 3A2 15A3 001T2 ..... 11A3/062 ..... 23A2 128S2 ..... 37S2 148A1
12 4A3 16S2 002A3 ..... 13A2/046 ..... 23A3 137A3 ..... 89A4 084S2
13 5S3 17A3 003A3 ..... 14S2/064 ..... 25A3 712S2 ..... 139S2 085A1
14 6A2 18A3 003T2 ..... 15A2/047 ..... 26A3 917A3 ..... 081A2
15 7A2 19T2 004S3 ..... 15S2/045 ..... 26A2
16 8A3 24A3 005A2 ..... 16A3/052 ..... 37A2
17 8S2 112A3 010A3 ..... 17T2/057 ..... 46A3
18 9A2 112S2 070A2 ..... 18A2/055 ..... 58A2
19 10A3 129A2 071S3 ..... 19S3/050 ..... 59A2
20 10A2 139T3 074A3 ..... 24A2/089 ..... 67A3
21 11A2 415A2 076S2 ..... 35A3/048 ..... 79A2
22 12T2 812A3 078A3 ..... 69A2/081 ..... 89A2
23 12A3 919S2 ..... 103S2/056 ..... 101A3
24 ..... 114A2/059 ..... 102A2

```

STATUS DISPLAY

Figure 7 Huntington Beach Car Status Display

▼DISPATCHER INCIDENT DISPLAY

```

1
2 064 09:30 17342 COLEDO          APT:103B      RD 272 FB 53 BT 05
3 C INF:HABERFILL MARVIN P      ADD:          PH:714 830-2113
4 ASGN: 45C4 - 454 -
5 459R PRI: 3 MINOR INJURY TO MAN WHEN HIT BY CAR
6
7
8
9
10 R      T      O      L      E      W      V      P      R      M      X      C
11 039 042 044 045 046 047 048 049 050 051 052 053 054 056 057 058
12 059
13
14 # TYPE P TIME -----ADDRESS----- -INTERSECT ST- APT# RD# FB BT DEPT
15 063 211 -1 09:29 15211 BEACH                -                233-21-03 P
16 065 901T-1 09:35          CINDY                -GRAND            425-01-05 C
17 060 415 -2 09:20 19232 BEACH                .                280-29-01 P
18 061 594 -3 09:23 17201 ADAMS                .                321-69-08 P
19 062 459 -3 09:27          GOLDEN WEST        -MC FADDEN        231-23-08 P
20
21
22
23
24

```

Figure 8 Huntington Beach Incident Display

incident display by the dispatcher, the AVL system automatically places the location of the incident at the center of the display and zooms in to an area which contains a minimum finite number of available patrol units. The selection of the nearest unit or units for dispatching is then carried out with the aid of this situation display. A similar AVL display is incorporated in the St. Louis FLAIR system (Figure 9). \*

After reviewing the various aids available to the complaint clerk and the dispatcher, we have concluded that push-button dispatching is now technically feasible. With CAD, AVL, Digital Data Links, and mobile teleprinters, a complaint clerk could dispatch a patrol by push-button immediately after entering the incident address, thereby getting the nearest available vehicle on the way 10-15 seconds after a call is received. The full details of the case could be transmitted to the car en route after the complaint form had been completed. Meanwhile, however, the vehicle is in transit. With an automatic telephone-address lookup, the dispatch could be made even sooner on the assumption that the call is from a phone in the vicinity of the incident. Pushbutton dispatching, of course, would profoundly alter the role of the present dispatcher. He could devote more time to the tactical management and support of field units, for example, by sending backup patrols where needed, by redeploying his forces dynamically to cover unprotected areas, and by supplying information on hazards, stolen vehicles, warrants, etc. as required to assure the safety of his men.

d) Travel Time - For calls within a given sector of area A, Larson (Reference 13) has derived the following approximate formula for average travel time (T):

$$T \approx \frac{2}{3V} \sqrt{A} .$$

This result assumes that the patrol cruises randomly throughout the entire area and that, in responding to a call, it proceeds along an E-W, N-S street grid at an effective speed V, which is not a function of the

---

\*FLAIR is a registered trademark of the Boeing Company.

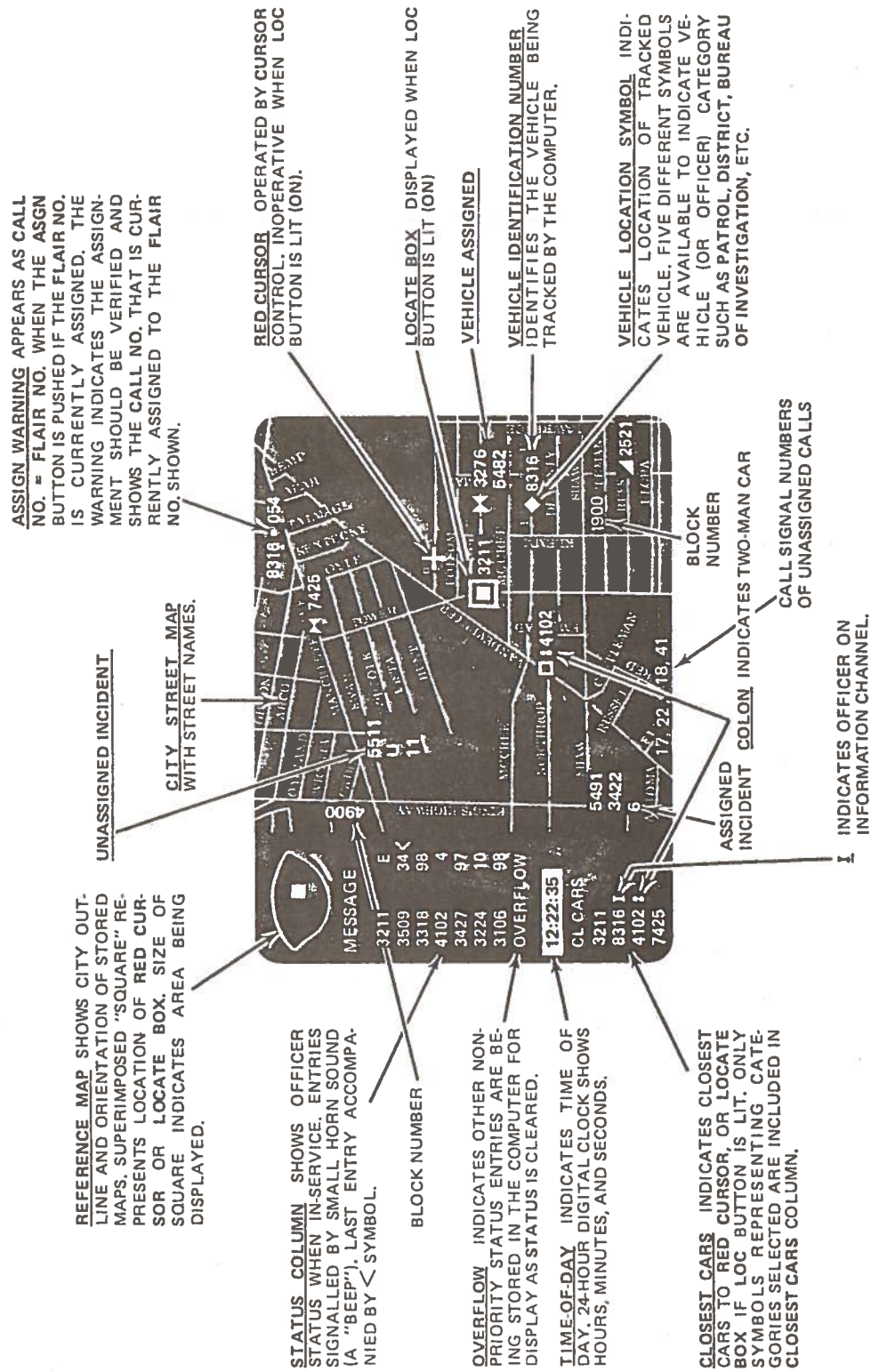

Figure 9. Typical Map Elements of The FLAIR Display



direction of travel. Incidents are assumed to occur with equal probability in all parts of the sector. A plot of travel time vs. sector area is given in Figure 10 for various values of speed.

6) Reducing Travel Time, If, with pushbutton dispatching, the dispatch delay can be reduced to about 15 seconds, the dominant component in overall response time becomes travel time. Larson's simulation results in Figure 6 show that closest-car dispatching made possible by AVL reduces the average travel time about 0.50 to 1.0 minutes depending on the patrol system's utilization factor. Emphasis must be placed on reducing the response time in emergency cases (crime-in-progress, accidents, officer in trouble, etc.) and for this class of cases, the following steps could be implemented:

a) Preemption - Adopting a procedure whereby an emergency can preempt a non-priority call, i.e., if a patrol is busy on a non-priority case, it can be reassigned to an emergency. Since emergencies are a small fraction of all calls for service, this rule would guarantee that practically the entire patrol force, including the sector car, would be available for an emergency assignment. At high utilization factors, sector cars are frequently busy or out of their own sector and the dispatcher is often forced to assign a car from a remote sector to a case. The average travel time under such circumstances will be much greater than that predicted by Larson's formula. In Boston, for example, the average travel time on priority one incidents is 5 minutes, although with an average sector area of 0.57 square miles, Larson's formula would lead one to expect a value of only 2 minutes at 15 mph. The difference is due to the large number of inter-sector dispatches. When no cars in the precinct are available, the incident is placed in queue until a patrol somewhere in the precinct completes its current assignment. Queue time, in this case, is added to travel time.

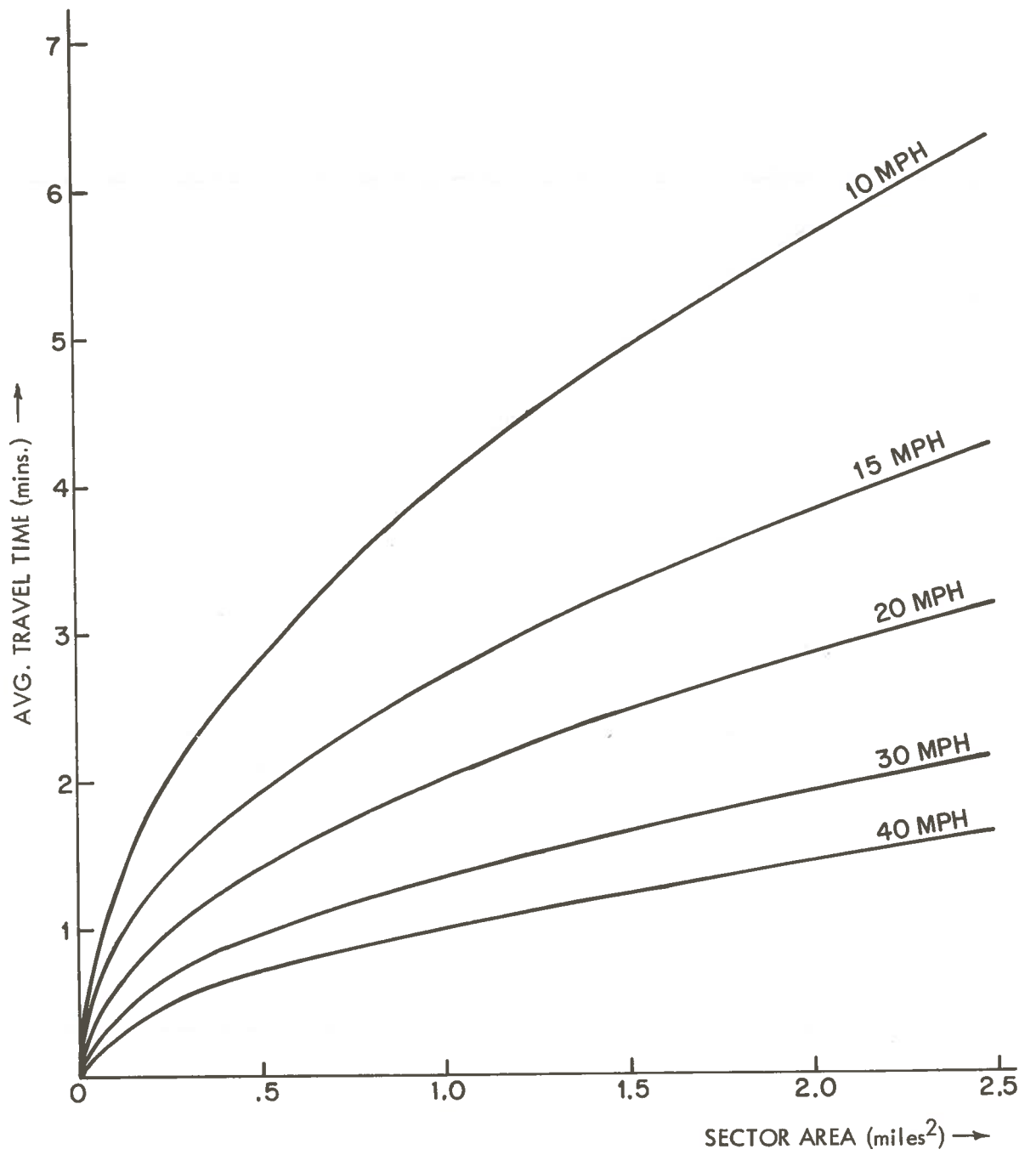

Figure 10 Average Travel Time as a Function of Sector Area and Effective Speed

- b) One-Man Cars - Given the same total police budget, the use of one-man instead of two-man cars almost doubles the number of patrol units, which effectively halves the sector area (A) in Larson's formula and reduces the average travel time by a factor of 0.7. The risk associated with one-man cars can be partially alleviated by always dispatching two vehicles to a potentially hazardous case.
- c) Dispatch Strategy - A great variety of sophisticated dispatching strategies and force deployment techniques are made possible by the CAD and AVL systems and these can be used to reduce travel time and to prevent queues from forming in any precinct (Reference 13, 16). For example, adjacent sector cars can be coordinated in the following way. If a car in one sector becomes busy, a car in any of the adjacent sectors can be moved to a fixed position on the boundary line between sectors. In this position, it is able to respond more quickly to subsequent calls in either its own or the neighboring sector. If the precinct gets too busy to cover all the sectors in this manner, additional vehicles can be sent into the area by the watch commander. These vehicles can be transferred from less busy adjacent precincts or from a special tactical force specifically created to alleviate momentary overloads in all the precincts. The object of these strategies is to always have a vehicle available in each sector which can respond to an emergency call. If this is done, the average travel time for emergency cases will be the value predicted by Larson's formula. Beyond that, a city can only reduce response time by deploying more patrols. This costs money, a resource which most municipalities are short on today.
- 7) Benefits of Reduced Response Time, We have hypothesized that, with CAD, AVL, Digital Data Links, and mobile teleprinters, pushbutton dispatching can be implemented and that this will reduce average overall police response times to less than 3 minutes. What would be the benefit of such an improvement? Using a simulation model of the dispatch and apprehension

process, the Aerospace Corporation has produced the plots shown in Figures 11, 12, and 13 for the cities of Montclair, New Orleans, and New York respectively. The "dispatch delay" in their model is the time from the initiation of the crime to the time a car is assigned. A 5-minute "dispatch delay" in the Aerospace plots would be equivalent to a 3-minute crime and a 2-minute dispatch delay as we have defined the term. This assumes that the victim calls immediately after the crime has been committed. A 0.5 minute "dispatch delay" would only be possible if the victim triggered a direct alarm as the crime commenced and the necessary information were relayed almost immediately to a patrol. The push button dispatching performance discussed in this final report would, in Aerospace's terms, be equivalent to a 3-minute crime followed by a 911 call and the complaint clerk transaction, i.e. a "dispatch delay" of roughly 3.5 minutes. The dashed line on each of the graphs represents our estimate of how push-button dispatching would perform in the Aerospace simulation model. Aside from the fact that the model produces the correct arrest rate (approximately 20%) for Montclair, New Orleans, and New York City under present operating conditions in those cities, there is no experimental evidence that it is valid for shorter response times. Our use of the Aerospace results to assess the benefits of pushbutton dispatching, therefore, is tentative. With this reservation kept in mind and retaining the present car density, Figure 11 predicts a change in the arrest rate in Montclair from 0.21 to 0.37 (+76%). Figure 12 predicts a change in the arrest rate in New Orleans from 0.24 to 0.40 (+67%). Figure 13 predicts a change in the arrest rate in New York from 0.21 to 0.29 (+38%). If these predictions are valid, the introduction of pushbutton dispatching would clearly be very cost effective. Note, however, that the improved performance is not due to AVL alone, but to the combined effect of AVL, CAD, digital data link, and mobile teleprinters operating as an integrated pushbutton dispatch system.

Crime related incidents, in practice, are not distributed evenly over a city's area, consequently patrol vehicles are usually more concentrated in the high-crime, high-demand-for-service zones. In Boston,

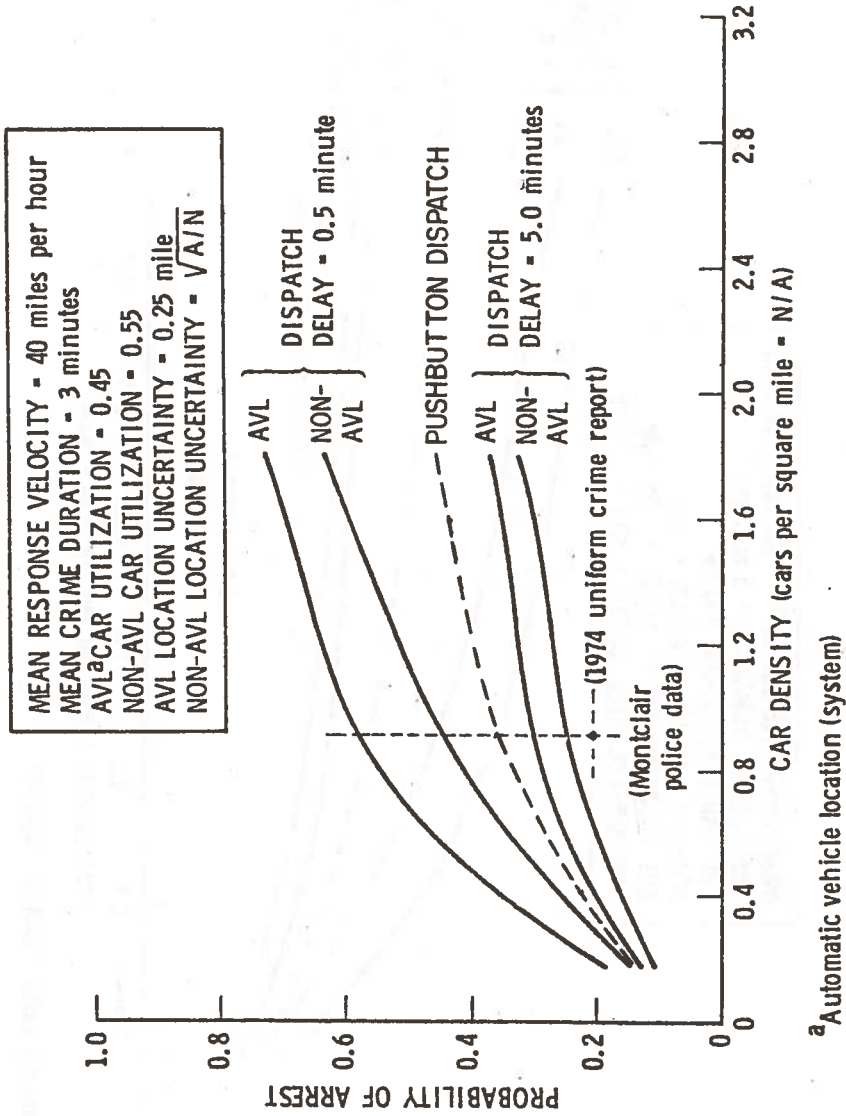

Figure 11 Suburban Scenario, Automatic Vehicle System Benefits (Montclair CA)

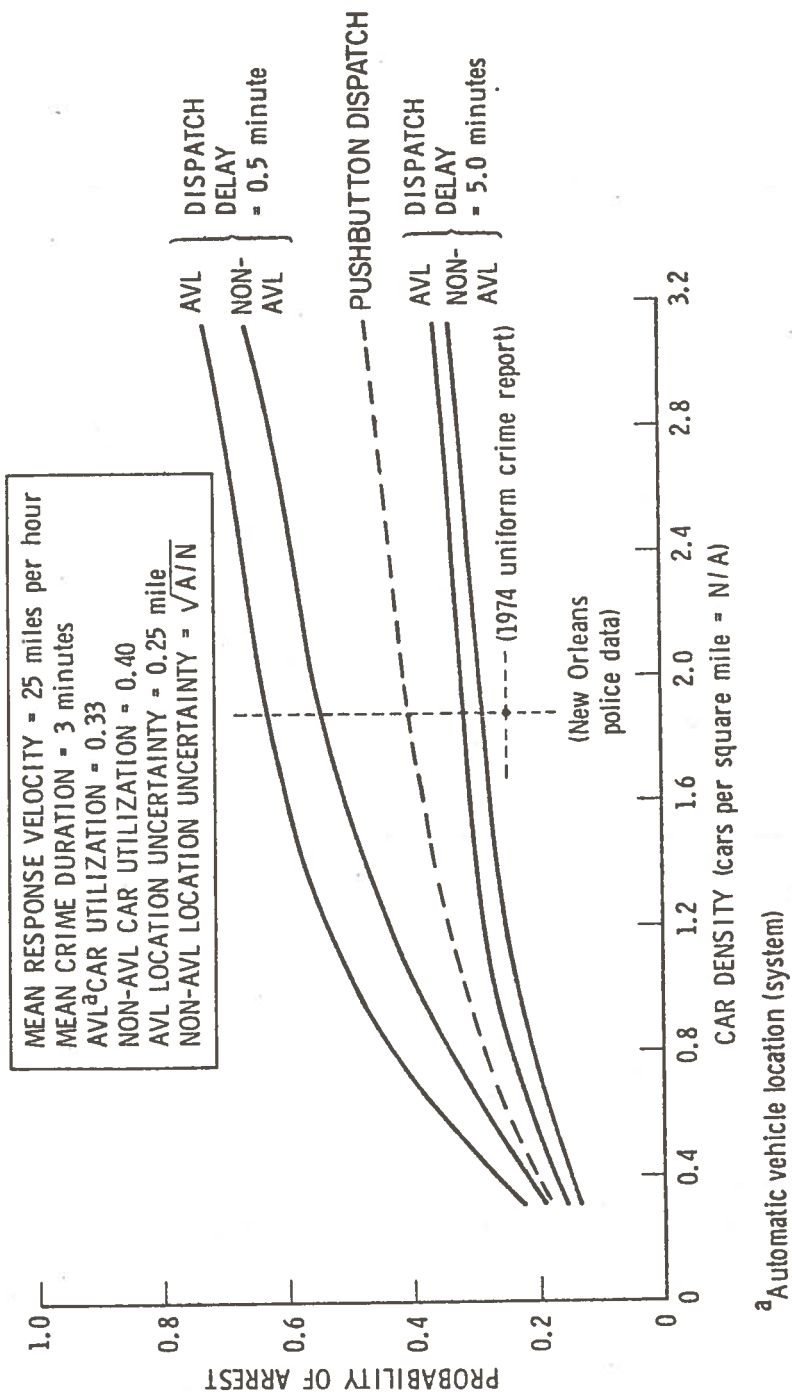

Figure 12 Urban Scenario, Automatic Vehicle Location System Benefits (New Orleans LA)

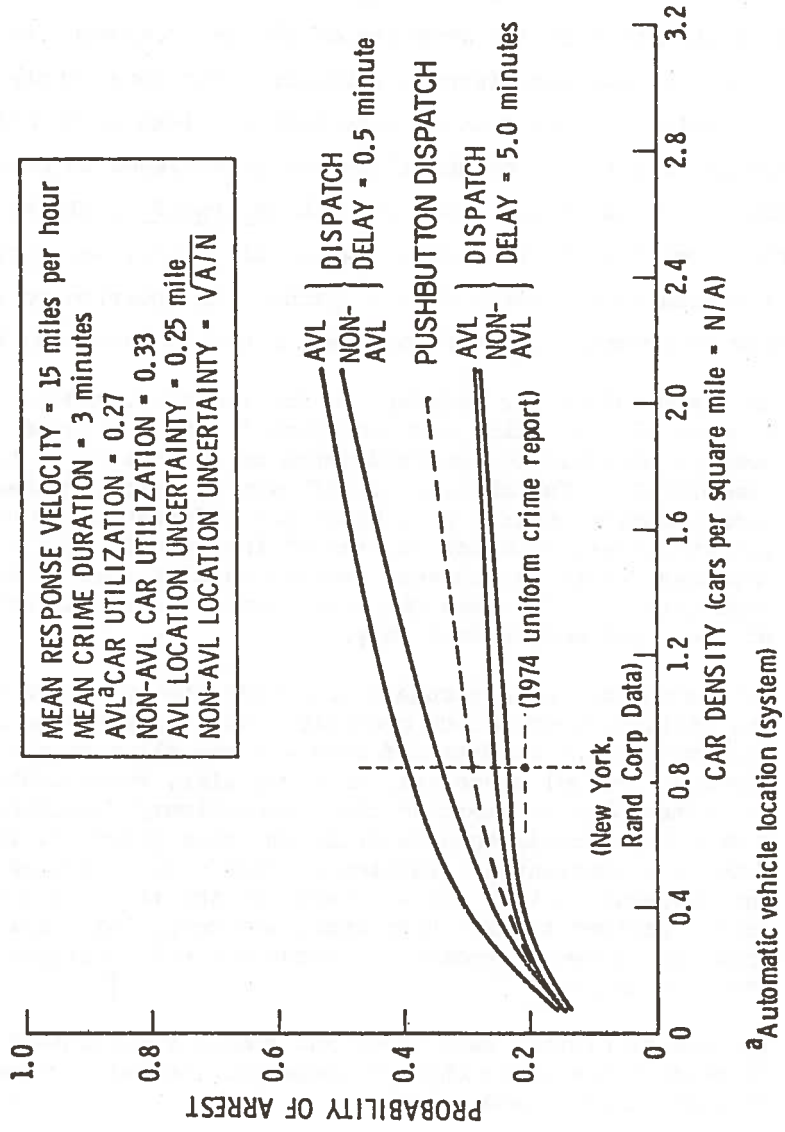

Figure 13 Metropolitan Scenario, Automatic Vehicle Location System Benefits (New York City Precinct 103)

for example, car densities range from 6.6 vehicles per square mile in District One to 0.6 vehicles per square mile in District Eight. Counterbalancing this, to a degree, is the fact that response speeds tend to be lower in the busy Districts and utilization factors higher. Ultimately, a definitive judgement on the benefits of shorter response times must be based on more adequate experimental evidence. The data, analyses, and simulation results we have seen to date however, lead us to believe that an increase in arrest rate of about 50% can be achieved in most cities with pushbutton dispatching. This benefit by itself would more than justify the investment in AVL, CAD, digital data link, and mobile teleprinters required to implement such a system. In addition to improved apprehension of criminals, other important benefits have been identified:

- a) Enhanced safety for officers in the field. Emergency status signals via data link combined with location information make it possible to send assistance to an officer in trouble immediately. The ability of officers to quickly access comprehensive central data bases for information on vehicle registrations, criminal records of individuals, and hazards associated with an incident address enables them to exercise extra caution when the situation calls for it and to do their job more effectively.
- b) More complete, more accurate, and more timely record-keeping and monitoring of police operations will improve the real-time management of patrol forces and the allocation of resources. Patrol sergeants, in particular, would probably be better able to exercise their supervisory functions at a dispatch console than by cruising their precinct. Red tape is a substantial fraction of each officer's workload; any decrease in this activity adds to the time available for more important tasks. Dispatcher and complaint clerk workloads are likewise reduced. Coordination of multiple vehicles would be easier.
- c) The use of digital data links and mobile teleprinters will decrease voice radio channel congestion and will enhance message security and accuracy.
- d) Faster response time is a benefit not only in crime-related cases, but also in medical emergencies and incidents, such as family arguments, that might escalate into crimes.



8) AVL Requirements for Law Enforcement, Having concluded that there are worthwhile benefits to be realized from the application of AVL to police command and control systems, we next tried to specify the AVL requirements imposed by such systems. The primary parameters of interest are accuracy, update rate, coverage, and cost. Data link requirements will be discussed in a separate section.

a) AVL Accuracy - In Figure 6, the average patrol car travel time as a function of utilization factor was presented for two dispatch techniques simulated by Larson (Reference 13):

1. Strict Center of Mass Dispatching
2. Perfect resolution AVL with a car reassigned to the nearest incident when a queue has formed.

The simulation model was an array of 9 sectors, each one mile square, representing a typical precinct. Larson also ran tests on the same model for various levels of AVL resolution. The resolution was specified as a fraction ( $\sigma$ ) of the sector length, which in his model was one mile. The extra travel times for values of  $\sigma$  of 0.25, 0.15, 0.10, and 0 (perfect resolution) are given in the following table.

Table 1 Car Locator Resolution and Dispatch Error Characteristics (9-Sector hypothetical command; utilization rate  $\rho = 0.0$ )

	Strict Center-of-Mass Dispatching	$\sigma = 0.25$	$\sigma = 0.15$	$\sigma = 0.1$	$\sigma = 0.0$
Probability of dispatch error	0.27	0.23	0.17	0.11	0.0
Average extra travel distance, given dispatch error	0.31	0.23	0.15	0.12	0.0
Unconditional average extra travel distance	0.084	0.053	0.025	0.013	0.0

Note: Distance units are sector lengths = miles. Each table entry is based on a simulation run in which approximately 900 calls for service were generated. Dispatch error occurs if the assigned unit is not the closest available unit to the scene of the call. The "extra travel distance" is the difference between the distance traveled by the dispatched unit and the travel distance of the closest available unit. Here,  $\sigma$  = resolution (miles) of car locator system.

To relate the table with Figure 6, we note that the average extra travel distance imposed by strict center-of-mass dispatching is 0.084 miles. At 15 mph, this is equivalent to 20 seconds of extra travel time, which is exactly the difference between the two plots on Figure 6 at  $\rho=0$ . The strategy of preempting a car on a non-priority case to cover a priority case makes nearly all cars available for an emergency call. In terms of the model, this is equivalent to a utilization factor of zero for emergency responses, so the  $\rho=0$  case is significant.

The table above can be extrapolated to cover an array of nine square sectors having any arbitrary sector length simply by scaling (multiplying) the extra travel distances by the chosen sector length. The result of such scaling is plotted in Figure 14.

The most significant aspect of Figure 14 is that for small sectors, e.g.  $l \leq 0.5$  miles, the average penalty in extra travel distance is not great, even for center-of-mass dispatching. To illustrate, the nine patrol sectors in Boston's District 1 (downtown) have an average area of 0.15 square miles. This is equivalent to a 0.39 mile by 0.39 mile square (2060 ft. x 2060 ft.). As indicated on the graph, the average extra travel distance relative to a perfect AVL system is only 175 feet with center-of-mass dispatching. At 15 mph, this extra distance adds just 8 seconds to the average travel time. Averages are somewhat deceiving. What actually happens 73% of the time is that the correct car is selected. For these incidents, there is no penalty in extra travel distance, since the nearest car has been dispatched. In the remaining 27% of the incidents, however, the car selected is not the nearest car. The average extra travel distance for these cases is 0.12 miles (0.31 x 0.39) or 638 feet. At 15 mph, the extra distance adds 29 seconds to travel time. Thus, in roughly three out of four cases with center-of-mass dispatching, the correct vehicle is selected regardless. In the fourth case, the vehicle chosen is not the nearest one and a significant average penalty in travel distance and time is incurred. Averaged over all the dispatches, however, the penalty is not great. We conclude, therefore, that in the

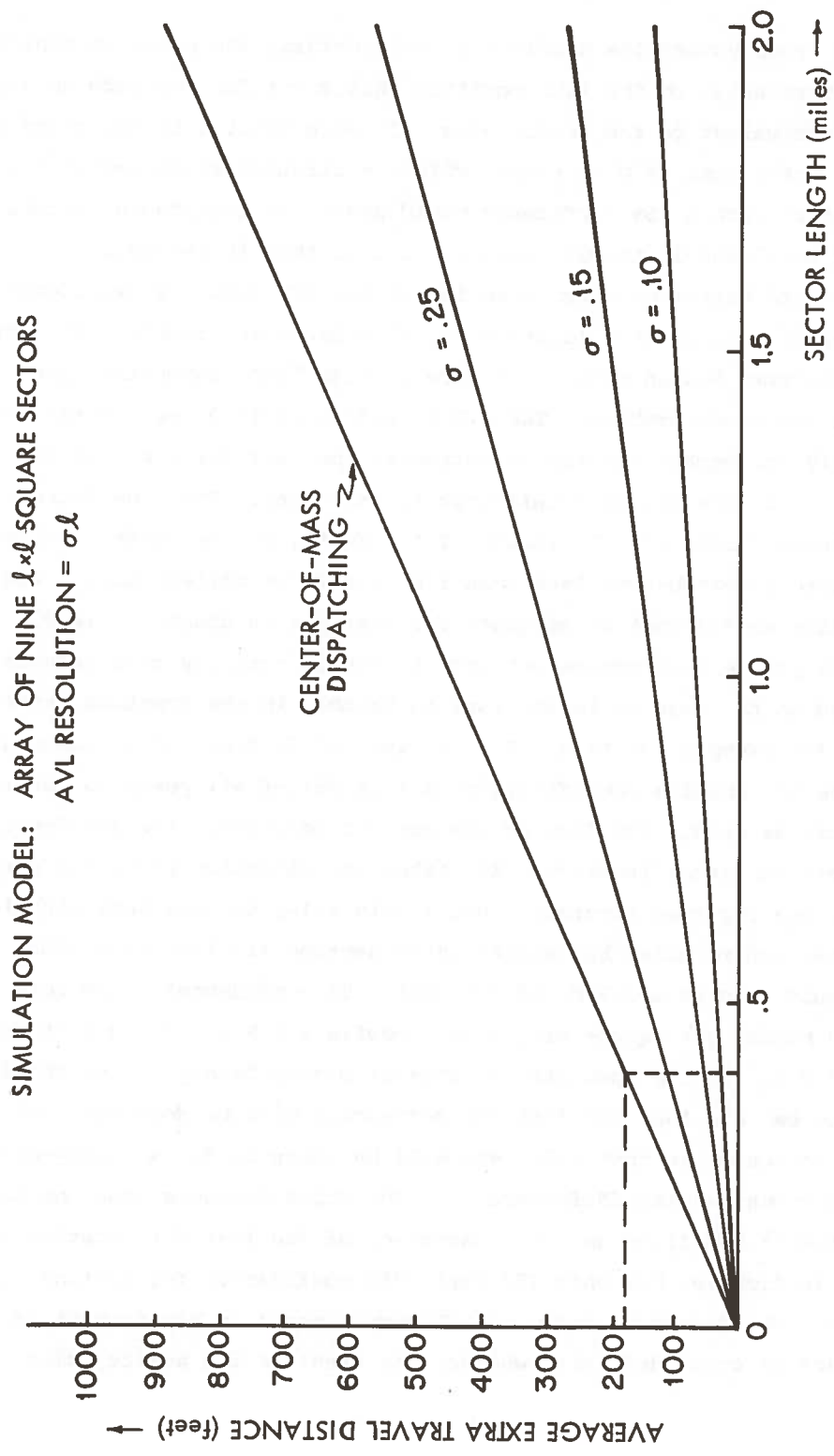

Figure 14 Average Extra Distance Traveled Relative to a Perfect AVL System

downtown areas having the smallest patrol sectors, the error in vehicle placement relative to the true position should not fall outside an area roughly equivalent to the sector area. In more precise terms, given a minimum sector area of 0.15 square miles, a circular error probability of 1200 feet with a 95% confidence would assure an acceptable average level of penalties in travel time, i.e., less than 10 seconds.

A second criterion often used in setting AVL accuracy requirements is the ability to quickly locate a patrol vehicle in trouble. The street map of downtown Boston shown in Figure 15 with four concentric location zones indicates the problem. The C.P.E. radius of 1200 feet (outer circle) is clearly inadequate for search purposes; the hunt for a patrol in trouble could take almost a half-hour in this area. The zone defined by the inner circle (C.P.E. radius of 400 feet), on the other hand, could be completely searched in less than 2 minutes. We believe that a 400 foot C.P.E. (95% confidence) is adequate for searches in downtown areas.

Some police departments set very stringent accuracy requirements on AVL based on the need to locate cars in trouble in the downtown environment. Dallas, for example, wants a C.P.E. radius of 75 feet for a stationary car. The Los Angeles specification is that 95% of all position determinations must be within 300 feet of the correct location. The Jet Propulsion Laboratory AVL study (Reference 14) takes the dimension of half a city block as the required accuracy. Under this rule, Los Angeles, with 166 blocks per square mile, has blocks which average 410 feet on a side, hence would require a C.P.E. of 205 feet (95% confidence). New York City with 240 blocks per square mile would require a C.P.E. of 170 feet according to J.P.L. In the open street grids of Orange County, three Chiefs of Police believe that 800 foot AVL accuracies will be required, but the general consensus is that 1000 feet will be adequate for a county-wide law enforcement system (Reference 1). The Urban Sciences Study on Boston (Reference 8) specified an A.V.L. accuracy of 300 feet for locating a vehicle in trouble, but only 750 feet (95% confidence) for routine dispatching. The Polhemus review of AVL requirements in New York State (Reference 4) concluded "that whether the event is for police, fire,



Figure 15. Comparison of C.P.E. Radii with the Street Map of Downtown Boston

or ambulance services, repeatability on the order of 200 to 250 feet would be quite acceptable. In urban areas, and in particular case areas, greater resolution is necessary with a level of repeatability on the order of 130 feet being reasonable."

Perhaps it is a mistake to impose the stringent accuracy requirement of finding a vehicle in trouble in the downtown area on the entire AVL system. A possible alternative would be to develop special equipment for homing in on vehicle or walkie-talkie emergency transmissions at close range. We will withhold judgement on this suggestion until a reliable estimate of the cost of providing 100 to 400 foot AVL accuracies in the downtown environment has been obtained.

b) Update Rates - Update rate requirements for police AVL systems are closely related to position accuracy requirements in that car motion during the update period can place a vehicle a considerable distance away from its last reported position and increase the chances of an incorrect assignment. In effect, vehicle motion during the update interval increases the dispersion of position estimates relative to the true position, hence the distance travelled should be a small fraction (say 20%) of the position accuracy desired. First of all, we assume that a vehicle in which the emergency button has been activated will be at rest, hence the 400 foot C.P.E. requirement for finding a car in trouble is not the accuracy specification to use in setting the update interval. The correct model is an unassigned vehicle on patrol (10-25 mph) for which, by our estimate, the desired C.P.E. (95%) in position is 1200 feet. A general relationship for update interval is:

$$\text{max. update interval} = \frac{.2 \text{ CPE}}{V} \quad \text{where } V = \text{Avg. patrol speed in ft/sec.}$$

Thus, in areas where the patrol speed averages 10 mph, the update interval should be about 16 seconds and where the patrol speeds are 25 mph., the update interval is reduced to 6 seconds. Actually, an accurate position determination is only necessary just prior to an assignment.

If there are no incidents awaiting service, a standby update period of 60 seconds would probably be acceptable. A reduced update rate during standby conditions makes more capacity available for other digital messages transmitted on the same channel. Furthermore, when a call for service is received, it is not necessary to update the location of the entire fleet. Only those cars in the precinct from which the call is received will be involved in the dispatcher's choice, hence only their locations need to be updated. It is the polling of this smaller group of vehicles that should require no more than 6 to 16 seconds, depending on patrol speeds, as indicated previously. A group of cars that has been polled in response to a call for service need not be polled again during the current fleet update period of 60 seconds.

Another approach to analyzing position update requirements was presented by the Jet Propulsion Laboratory in Reference 14. In this study, an exponential distribution of vehicle speeds was assumed with a median speed of 15 mph. The tradeoff between polling interval and the accuracy of the AVL technique employed is shown in Figure 16 taken from the JPL report. To illustrate the use of this plot, an overall position accuracy of 300 meters (984 feet C.P.E. at 95% confidence) requires an AVL device accuracy of 270 meters and an update interval of 10 seconds. The overall accuracy diminishes rapidly if the polling interval goes above 10 seconds, but it does not improve appreciably if the interval is less than 10 seconds.

In reviewing the update interval requirements set for various AVL systems, we find that they range from 1.25 seconds (Boeing FLAIR) to the poll-on-demand technique in effect at Huntington Beach (Hoffman). Boeing's high update rate is dictated by the need for their dead reckoning and map matching algorithm to detect turns quickly, otherwise a vehicle can be placed on the wrong parallel street. Huntington Beach uses one UHF channel for both voice and AVL position reports, with voice having priority. For this reason, AVL loading is kept to a minimum by only polling vehicles prior to a dispatch.

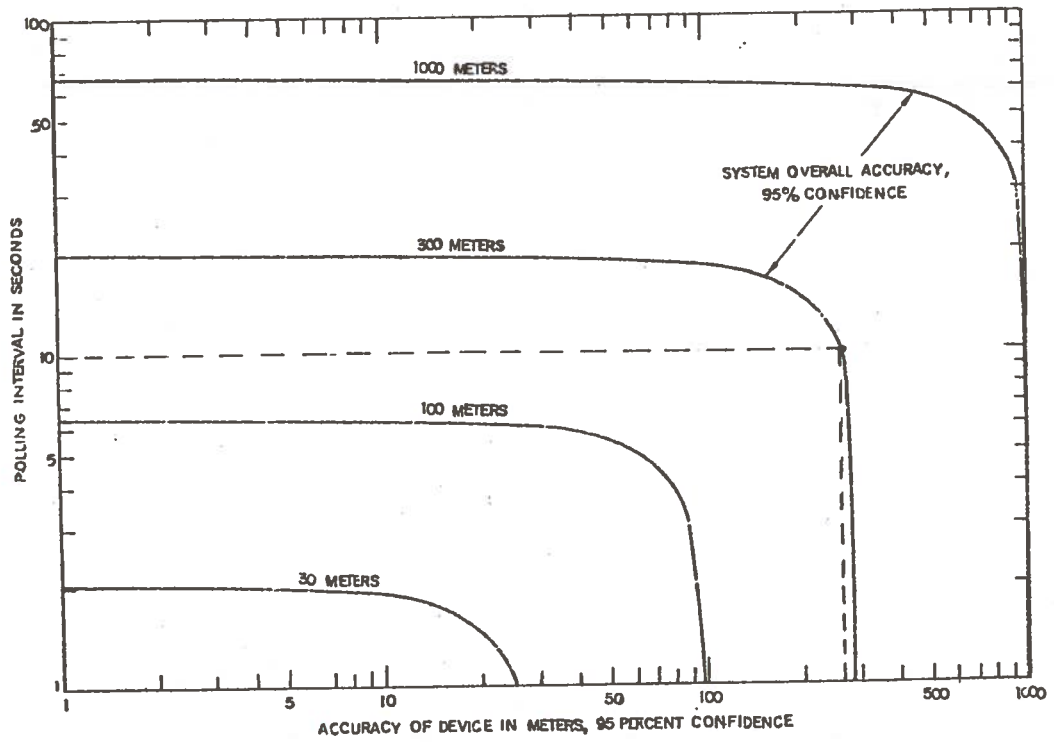

Figure 16 AVL System Accuracy versus Update Rate



In Montclair, a position report is transmitted to the dispatch center automatically when a vehicle enters the coverage area of the next signpost on its route. The update rate, therefore, is determined by the spacing of the signposts and the speed of the vehicles. As shown in Figure 17, the street grid of Montclair is based on a 2400' x 1200' block, so signposts at the intersections are 65 to 33 seconds apart at 25 mph.

The Dallas AVL system being developed by Hazeltine will have a maximum update interval of 10 seconds, with the condition that there shall be at least one update for every 300 feet travelled by any one vehicle. The Los Angeles multi-user demonstration system (transit and police) will require each vehicle to be updated at least once every 40 seconds, with a design goal of one update per vehicle every 25 seconds. The Urban Sciences study on the Boston AVL system (Reference 8) concluded that vehicle positions should be monitored every 30 seconds on the average, with the ability to monitor selected vehicles more frequently if necessary.

c) AVL Coverage - AVL coverage requirements for law enforcement applications are very much situation dependent, ranging from small cities to entire states. The following table of actual or suggested police systems, presented in order of increasing area, indicates the range of applications.

Jurisdictions	Area (square miles)	Population (1973)	Number of Vehicles
Montclair, California	5.2	27,000	15
Huntington Beach, California	26.5	146,400	54
Boston	46	618,000	273
Montclair, Ontario, Upland, Chino	50.2	143,000	62
St. Louis	61.2	558,000	436
Chicago	222.6	3,173,000	1561
Dallas	265.6	816,000	479
New York City	299.7	7,647,000	1858
Los Angeles	463.7	2,747,000	1622
Orange County (25 cities included)	784	1,697,000	545
New York State	49,576	18,214,000	8800*

\*800 State Police Vehicles, 2500 rural local police vehicles, and 5500 urban local police vehicles.

CITY OF MONTCLAIR

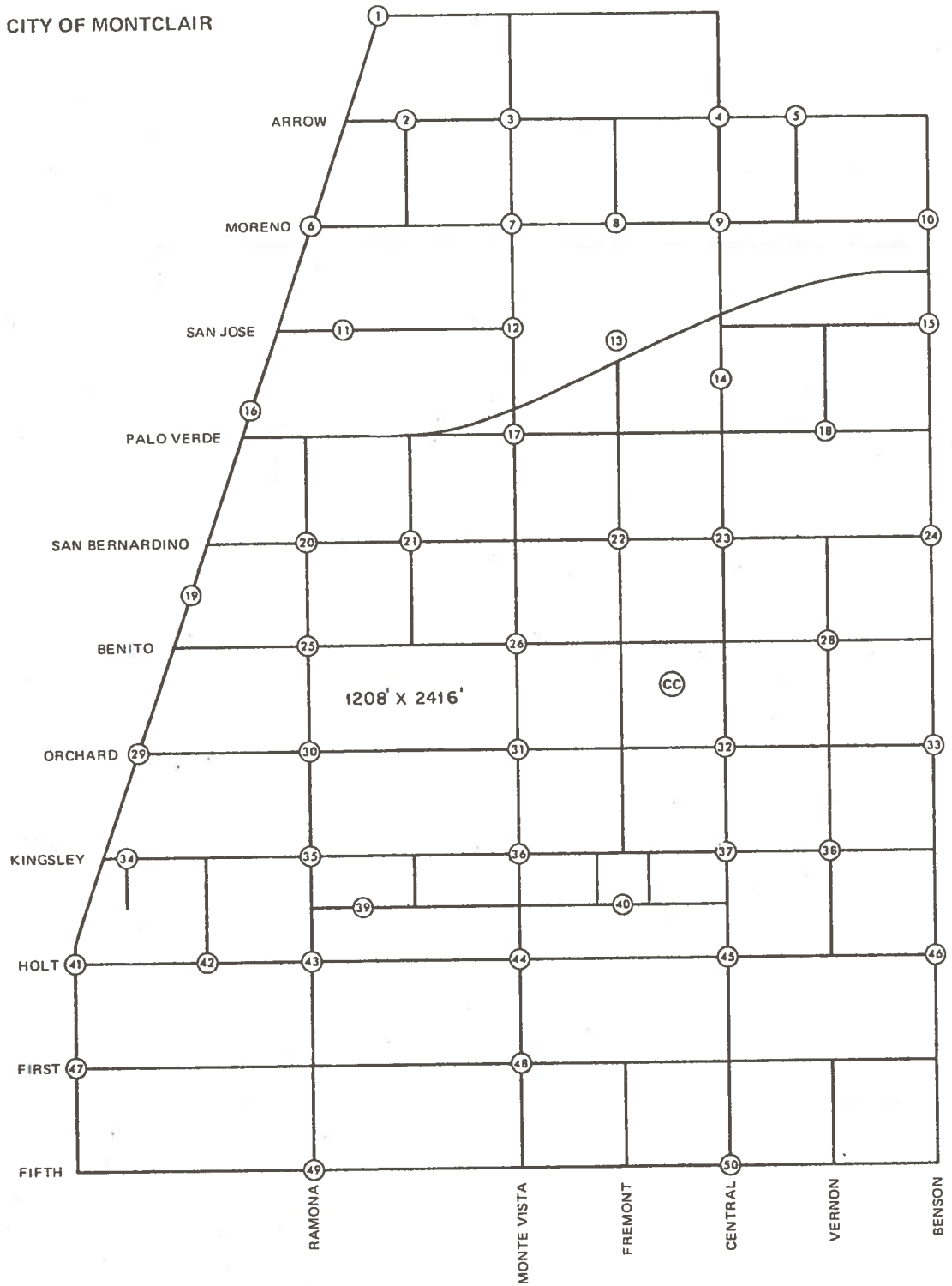

Figure 17 Placement Of Wayside Emitters In Montclair

d) AVL Cost Requirements - The tendency of police departments committed to a greater degree of automation is to proceed on a piecemeal basis by implementing CAD, mobile data terminals, or AVL separately. The order of procurement varies from department to department. St. Louis and Montclair installed an AVL system first. Huntington Beach started with CAD and mobile data terminals, later adding an AVL capability. Boston installed CAD, but not mobile data terminals or AVL. Several cities such as Oakland, Kansas City, Cleveland, and Minneapolis fitted their vehicles with mobile data terminals, which are used primarily to access a centralized data base, but have not yet procured a CAD system.

Generally, the benefits received from the installation of AVL, CAD, or MDT alone are marginal. Expenditures are much easier to justify on the basis of a totally integrated system, one capable of push-button dispatching and extremely short response times. As discussed previously, a 50% increase in the present arrest rate appears to be achievable if overall response times can be reduced to less than 3 minutes. Such performance is feasible with a combined CAD, MDT, and AVL system that permits push-button dispatching.

This does not imply that the total effectiveness of a given police force can be increased by 50%, because the police perform many useful services that are not crime related. Speed of response, on the other hand, is advantageous for a variety of non-criminal incidents, e.g. medical emergencies and family quarrels. We conclude, somewhat heuristically, that a community would probably be willing to spend 25% more to support its patrol functions, if, thereby, a 50% increase in arrest rate could be achieved and response times could be reduced below 3 minutes.

The total annual cost of operating a one-man patrol car 24 hours a day is about \$100,000 (salaries, maintenance, fuel, administrative overhead, etc.) and a 2-man car costs twice as much, i.e. \$200,000 (References 1, 8, 9, 10). A 25% increase in the support level for patrols therefore, is equivalent to \$25,000 per year for each one-man vehicle and \$50,000 per year for each two-man vehicle. If one assumes that the entire investment in CAD, MDT, and AVL equipment must be amortized in 5 years

at 7% interest, then the maximum acceptable capital investment as a function of the number of cars in the fleet is plotted in Figure 18. A fixed annual maintenance cost, estimated to be 5% of the initial capital investment, is included in the annual charges. Superimposed on the plot are a few actual or estimated system costs, which, in most cases, are an order of magnitude lower than the acceptable maximum. The three operational systems (Huntington Beach, Montclair, and St. Louis) were all prototypes for the respective vendors, and presumably, the costs will decrease for comparable equipment in time. The final conclusion is that integrated CAD, AVL, and MDT systems could be provided that would be cost effective for a wide range of police departments. The key assumption requiring further validation, however, is that such systems will reduce overall response time to less than 3 minutes and that the reduction will increase the arrest rate by at least 50%.

## 2.2 Taxicab Dispatching and Security

The taxi dispatching problem is similar to the police dispatching problem, the objective being to select the nearest available car to answer a call. Under present procedures, the correct vehicle is often not assigned and, as a consequence, fleet operating expenses are higher than necessary.

In the last comprehensive traffic survey in the Eastern Massachusetts region (Reference 17), the following breakdown of taxi trips on a typical weekday was given:

### INTERNAL TAXI TRIPS BY BUSINESS PURPOSE

Average Weekday - 1963

<u>BUSINESS PURPOSE</u>	<u>NUMBER OF TRIPS</u>	<u>PER CENT</u>
Home Base	13,595	7.3
Personal Use	300	0.2
Taxi Stand	17,224	9.2
Pick-up Passenger	65,864	35.2
Discharge Passenger	88,042	47.0
Pick-up Article	612	0.3
Deliver Article	675	0.4
Cruise	311	0.2
Other	460	0.2
	<hr/>	<hr/>
TOTAL	187,083	100.0
	40	

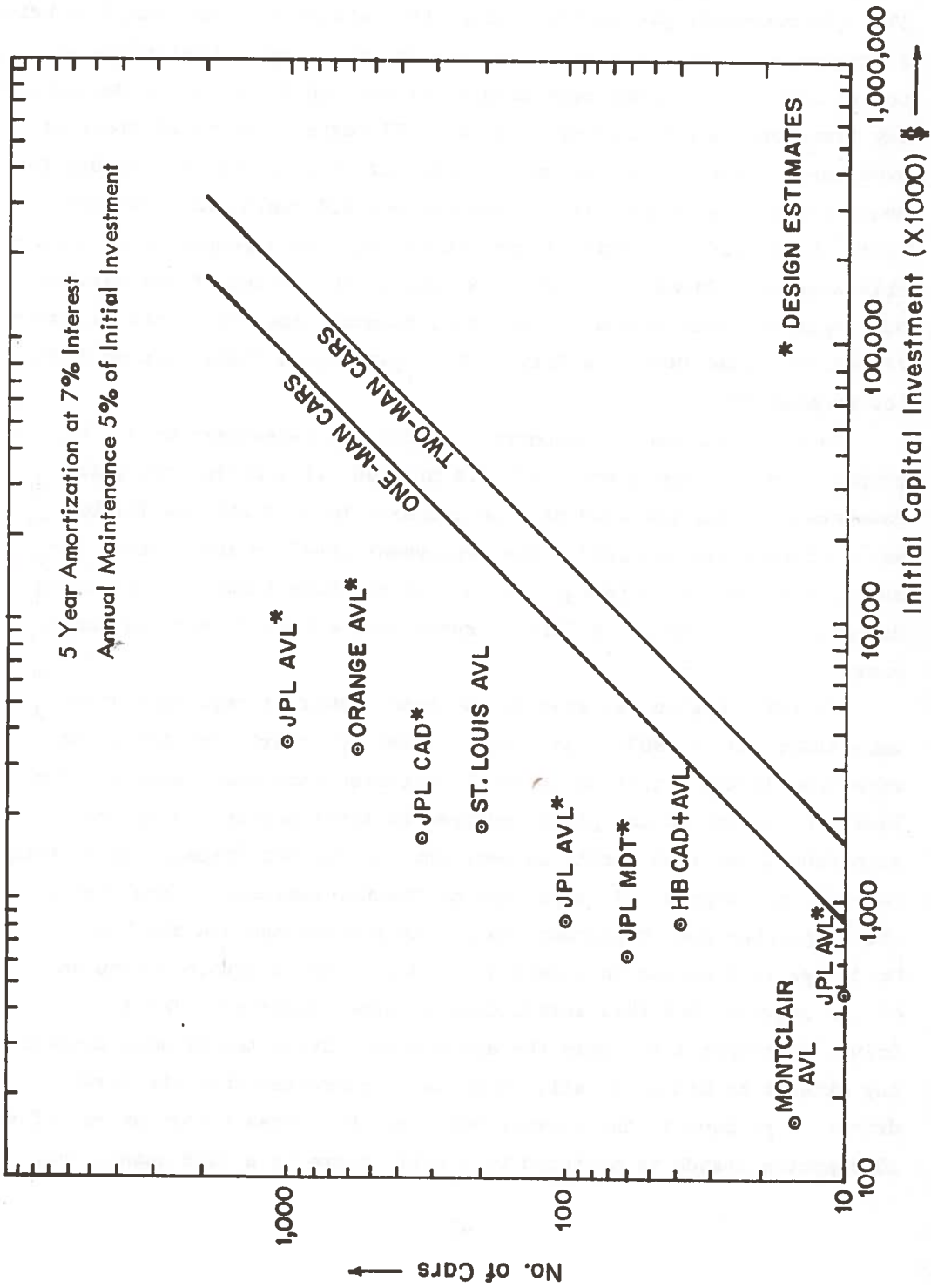

Figure 18 Capital Investment versus Number of Cars

Of the 88,717 trips to discharge a passenger or deliver an article, 66,476 (75%) were initiated by a dispatch operation. In the remaining 25%, the passenger presumably boarded the vehicle at a cab stand or hailed a passing cab. At the time of the survey, the City of Boston had 1525 registered taxis and the remaining 78 cities and towns in the Massachusetts Bay Transportation Authority area had 1473 taxis. The total fleet of 2998 taxis served a population of 2,614,522, i.e. there was one cab for every 872 residents overall and one cab per 404 residents in Boston itself. Nationwide, a ratio of one cab to every 1000 people is a reasonable average. There are 262,000 taxicabs in the United States serving 3361 separate communities. Most cabs, however, operate in the big metropolitan areas (New York City 11,977, Washington 8500, Chicago 4600, Los Angeles 985, etc.).

In 1973, taxicabs transported 3.4 billion passengers on 2.2 billion trips. Cabs covered a total of 13.4 billion miles during the year. Passenger revenue was \$3.9 billion compared to \$1.7 billion for bus and rail carriers combined. The employment level in the taxicab industry was 494,000, although, because of the high turnover rate among drivers, a total of 1.2 million persons were employed over the entire year.

In 1977, Boston has exactly the same number of registered taxicabs (1525) as in 1967. The largest fleet (Checker) dispatches its cars from 23 key locations (stands) scattered throughout Boston. The location closest to the pickup address is first determined by the dispatcher, and then a call is sent out for the top Checker cab at that location to respond. If there are no Checker vehicles at the stand, the dispatcher must broadcast the pickup address and ask for "bids." No driver is supposed to submit a bid unless he is within 3 minutes of the address, but this restriction is often violated. The first driver to submit a bid gets the assignment. Since ten or more drivers may attempt to bid on a call, there is no guarantee that the first driver to respond is the closest vehicle. Even when a taxi at one of the 23 dispatch stands is assigned to a call, there is a good chance that

some other available vehicle in transit is actually closer to the pick-up point. After a driver has dropped off a passenger or package, he is supposed to go to the nearest of the 23 dispatch stands and wait for a new assignment. Cabbies, however, will often move to another stand if the activity is low at their current location.

The distribution of all 350 reserved taxi parking spaces (stands) in downtown Boston is shown in Figure 19 (Reference 18). One possible vehicle location technique would be to number these stands and have the drivers transmit the number corresponding to their location to the dispatch center, along with status updates. The dispatcher could enter this information manually into a computer or, in a more sophisticated system, the driver could enter it directly via a mobile keyboard and digital data link. If the pickup address specified in a call is entered by the dispatcher, the computer can automatically select the nearest available taxi from its file of vehicle locations. As can be seen from Figure 19, taxi stands are spaced very close together in certain downtown areas and it would certainly be acceptable to designate such clusters by a single number or to sub-divide the whole area into small zones. Referring to the street map of downtown Boston in Figure 15, it appears that roughly a 800' x 800' zonal grid would be required in the most highly developed sections of the city for taxicab dispatching. The accuracy of any automatic vehicle location technique used for taxicabs should be comparable to this requirement, i.e., a C.P.E. of 400 feet with 95% confidence. Since vehicles are generally at rest while awaiting a new assignment, position updates could coincide with driver-initiated status changes, except when the emergency button has been activated. In the latter case, periodic position updates would be necessary.

The advantage of AVL over stand locations is that it provides a means of locating any vehicle quickly in the event of a holdup or an attack on the driver. A foot-actuated emergency button would be required, as well as a vehicle-to-base digital data link which could be monitored directly by the police dispatch center. As stated previously, there is a natural symbiotic relationship between taxi operators and

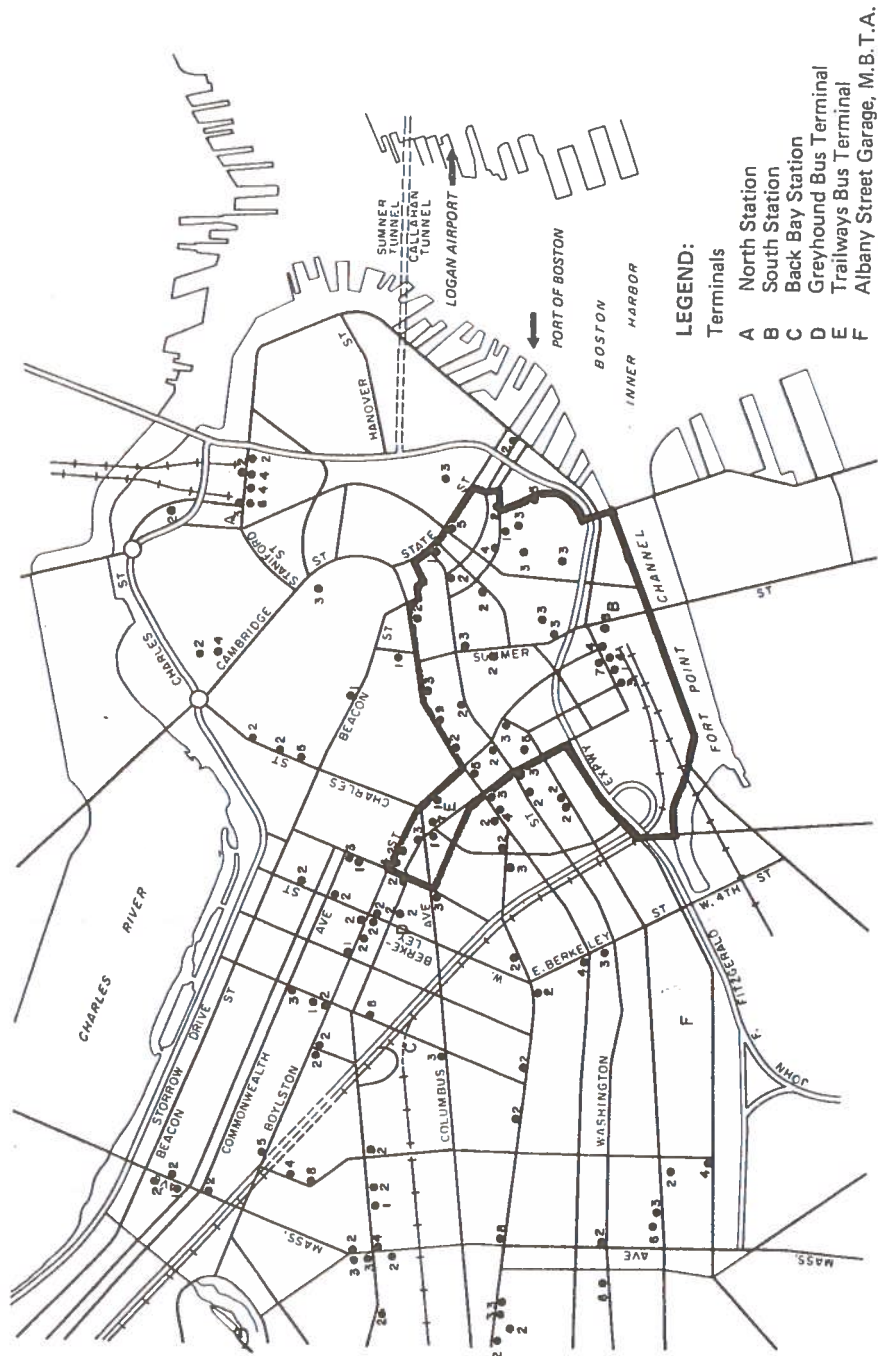

Figure 19. Location of Major Transportation Terminals and Taxi-cab Stands within Boston Proper; Boundary of the Central Area of Boston

SOURCE / Boston Redevelopment Authority



the police department that has never been fully exploited. In Boston, for example, the taxi fleet is five times larger than the police fleet. The use of taxicab drivers to detect and report crimes-in-progress, suspicious activity, and accidents would greatly enhance the effectiveness of police operations. In return, the police could provide the drivers themselves with much better protection if taxicabs were equipped with AVL and a data link monitored at the police dispatch center. Typically, there are between 700 to 800 taxicab holdups or beatings in Boston annually, and there have been 8 murders of taxicab drivers in recent years.

Technically, it seems to be quite feasible to combine the dispatch operations of all the city's cabs in a single system and to eliminate the present wasteful duplication of personnel and equipment. The company or independent operator selected by a customer would be identified by the trunk line on which the call is received. The central computer would select the nearest vehicle from that company's fleet and present this information to the dispatcher, who would assign the designated car to the call over the proper voice channel. The benefits to the police of a taxicab patrol auxiliary may be sufficient to justify their subsidizing the central elements of the system, leaving only the mobile equipment to be purchased by the cab owners. The functions of a taxicab system would be much simpler than those of the police systems discussed in the previous section, but the economic constraints are more severe also. In the Boston area, we have been told by Mr. Ted Kline, Editor of the Taxi News Digest, a cab must average about \$60 on the meter per shift to make the operation acceptable to the owners. A fleet cab, typically, is out for two 10-hour shifts per day, although an owner-operator might drive only one shift of 10 to 14 hours duration. A vehicle averages 100 miles per shift, half of which are paid miles, half unpaid. A fleet cab which satisfies Mr. Kline's income criteria, therefore, generates about \$43,800 in revenue operating two shifts for 365 days each year. Of this amount, the drivers receive 65% in direct and indirect compensation and the mileage-related expenses (amortization over life of

car, gas and oil, maintenance, accident insurance, tires, batteries, etc.) total about \$11,600 per year. A new taxicab costs \$4300 and a cab purchase loan is generally paid off over a 30 month period. The vehicle odometer, typically, records 60,000 to 70,000 miles each year, but because of the large amount of idle time, the engine probably "travels" about 100,000 miles per year.

With AVL and computer-aided dispatching, we believe that the average number of unpaid miles per shift can be reduced from 50 to 20. This would represent a 30% reduction in the mileage-related expenses or \$3480 saved per vehicle per year.

Based on the current pricing of police mobile equipment, providing AVL, status/emergency keys, and data link should require an investment of about \$2000 per taxicab. The centralized CAD facility serving all 1500 vehicles in the City of Boston should cost less than \$1 million because the functions and requirements are much less stringent than those for police CAD systems. Thus, if \$3480 can be saved in operating expenses per vehicle per year, the total required investment of \$4,000,000 would be more than paid off in one year. The mobile equipment could be expected to have a useful life of at least 5 years, and the central facility, a life of 10 years or more. These rough estimates indicate that an integrated CAD and AVL capability for taxicabs would be a profitable investment for the owners just on the basis of minimizing unproductive mileage. No attempt has been made to quantify the additional benefits of such a system, i.e., enhanced protection for drivers; overall reduction in dispatching expenses due to the consolidation of functions in one facility; augmentation of police functions by having cab drivers report crimes-in-progress, suspicious activity, and accidents; reducing the cab component of urban traffic and air pollution; fuel conservation; better data on the geographic and temporal distribution of taxicab demand enabling owners to allocate their resources more efficiently; detailed operational data for supervisory and record-keeping functions.

### 2.3 Fixed-Route and Dial-A-Ride Bus Control

1) Fixed-Route Headway Regulation. There are three potential benefits from the application of AVL to fixed bus routes; reduced headway dispersion, greater driver security, and increased efficiency in exercising supervisory functions. The first of these improvements would increase customer satisfaction in a number of important ways. For example, one of the most uncomfortable aspects of utilizing a bus is waiting at a stop to be picked up, especially in inclement weather (rain, sub-zero temperature, etc.). Customers tend to remember the occasional long delays under such conditions and not the average delay. A high dispersion in headway increases the probability that a long pickup delay will occur. The same factor adversely affects customers who are operating under a time constraint, e.g., those who must punch a time clock, attend a scheduled meeting, or catch a train. If a bus line has a high dispersion in headways, passengers cannot accurately predict how long a given trip is going to take, hence must allow a generous margin of safety by starting the trip earlier or must resort to a more reliable form of transportation.

When a long gap occurs between vehicles, the first bus to appear after the gap is often crowded because it has picked up the extra people who have accumulated at the previous stops. A bus operating at 160% of its seating capacity does not provide a comfortable ride for its passengers and chronic crowding undoubtedly diverts potential customers to other travel modes. If the passenger load were more evenly divided among the buses assigned to a route, overcrowding might be prevented, but large headway variations cause a significant fraction of the vehicles to be overloaded. Moreover, the well-known dynamic instability of a bus string tends to make every bad situation worse, both with respect to passenger loading and increased trip time.

Customer satisfaction (or dissatisfaction) can only be quantified by relating it in some way with the public's choice of travel modes. If improvement in service leads to a higher utilization of the transit system relative to private automobiles, important environmental objectives

are achieved (less traffic, reduced air pollution, fuel conservation, etc.) and the economic position of the transit system itself is strengthened, especially if the increased patronage occurs during the off peak hours. However, modal choices are based on a complex matrix of factors (References 19-23) which include trip time, cost, car ownership, economic status, comfort, convenience, trip purpose, time-of-day, trip distance, privacy, etc. Evidence indicates that the door-to-door travel time of public transit relative to the automobile is the dominant factor in the choice of travel modes. In general terms, if the trip time by transit is equal to the trip time by automobile, the public transit mode will be selected by about half the trip makers. If transit takes twice as long as the automobile, only 20% of the work trips will utilize transit and these are probably people who have no viable alternative. However, if transit takes half as long as the automobile, about 90% of all trip makers will select this mode (see Figure 20).

Unfortunately, a reduction in headway dispersion has no direct bearing on average trip time by transit, it merely increases the probability that the actual trip time will be approximately equal to the average trip time. For this reason, it is not possible to claim that a reduction in headway dispersion by itself will lead to a specific gain in the number of people utilizing public transit, even though customer satisfaction would clearly be increased by such an improvement. More precise adherence to schedules, however, will permit the use of shorter layover times and, thus, will result in reduced headways and shorter trip times.

Layover times at each end of a bus route are usually set with the object of preventing delays that develop in one trip from carrying over into the next trip. To illustrate, we will use data collected by Ward and Houpt (Reference 24) on the Dudley-Harvard route of the Massachusetts Bay Transportation Authority. This route is 3.7 miles long (one-way) and a round trip during the peak morning hours (7-9 a.m.) is scheduled to take 56 minutes, including a 6 minute layover at Harvard. The time interval between successive buses (headway) is 6.5 minutes and the lay-

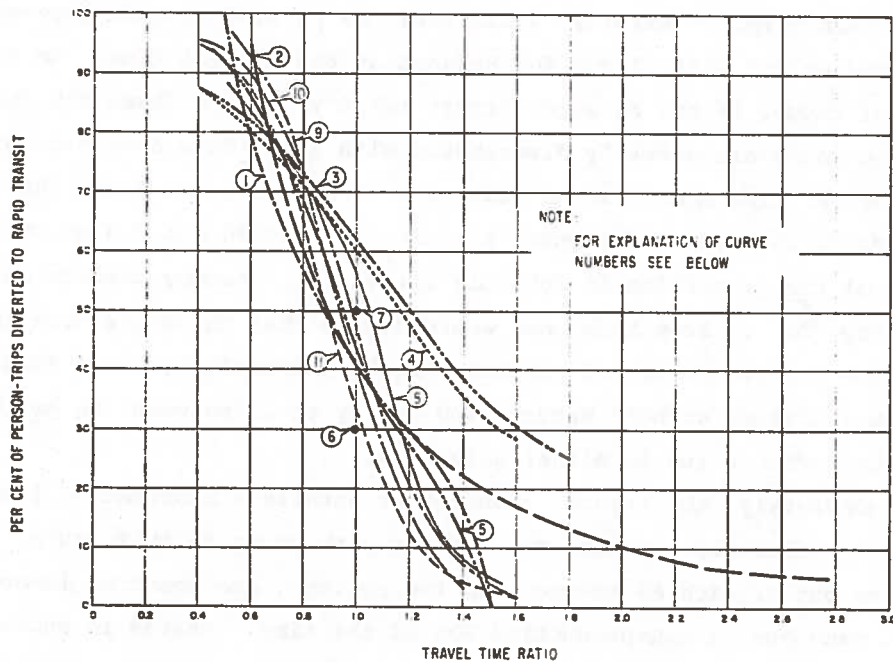

<u>CURVE NO.</u>	<u>CURVE DEVELOPED BY</u>	<u>YEAR</u>	<u>TO BE USED WITH</u>
1	Washington, D. C. Mass Transportation Survey	1958	Trips of all Types Potentially Divertable to Rapid Transit
2	Chicago Transportation Usage Study	1957	Work Trips to and from CBD and Outlying Areas
3	Chicago Transportation Usage Study	1957	Work Trips to and from CBD only
4	San Francisco Transportation Technical Committee	1959	All Trips of Interest to San Francisco Rapid Transit to CBD (All Orientations, All Times of Day, All Purposes)
5	Southern New Jersey Rapid Transit Study	1959	All Trips of Interest to Southern New Jersey Rapid Transit
6	Metro. Toronto Planning Board and Toronto Transit Commission	1958	Peak Period Transit Trips of all Types Divertable to Rapid Transit
7	Metro. Toronto Planning Board and Toronto Transit Commission	1958	Off-peak Period Transit Trips of all Type Divertable to Rapid Transit <sup>1</sup>
8	City of Seattle	N.A. <sup>2</sup>	All Trips of Interest
9	U. S. Bureau of Public Roads	1956	All Vehicular Trips of Interest to "Interstate" Freeway System
10	American Association of State Highway Officials	1957	All Vehicular Trips of Interest to Urban Freeways
11	American Association of State Highway Officials	1957	All Vehicular Trips of Interest to Urban Major Streets

<sup>1</sup>The two Toronto curves (6 and 7) are time-differential (time-saved) curves, rather than time-ratio. Therefore, the only plottable points are at 1.0 time-ratio (zero time-differential).  
<sup>2</sup>Not available.

Figure 20 Typical Transit and Highway Diversion Curves - Rapid Transit

over time at Dudley is 9 minutes. Thus, a bus could be up to 6 minutes late on the Dudley-Harvard leg and still leave Harvard on schedule on the return trip. Similarly, a bus could be up to 9 minutes late getting into Dudley and still leave for Harvard at the correct time. As a rough rule of thumb, if the measured errors relative to the fixed schedule on a given route are normally distributed with a standard deviation of  $\sigma$ , the layover time should be at least  $2\sigma$ . Ward and Houpt found that the dispersion in headway for buses arriving at Harvard was 6.3 minutes. In terms of the dispersion in schedule errors ( $\sigma$ ), headway dispersion is given by  $\sqrt{2\sigma^2}$ . From this, one would deduce that the dispersion in schedule errors ( $\sigma$ ) is 4.5 minutes. Ideally, therefore, there should be a 9 minute layover at both Harvard and Dudley to allow buses to get back on schedule after a run in either direction.

Obviously, the layover requirement entails a substantial loss of transit efficiency. During the morning peak hours on this route, 15 minutes out of each 65 minutes, on the average, are spent on layovers, i.e., each bus is non-productive 23% of the time. Stated in another way, the same transportation services could be provided by 8, instead of 10, buses assigned to the Dudley-Harvard route, if layovers were eliminated during the peak hours. Conversely, the 10 buses could be retained and shorter headways and trip times provided. According to Mr. Richard Barber, the Supervisor of Surface Line Scheduling for the MBTA, layover times for the entire bus system average 24.4% of each bus cycle over one full week of operation. On the busy routes, which employ most of the MBTA's 1200 active buses, layover time could be decreased in direct proportion to a decrease in headway dispersion. Providing a rest period for drivers between runs is not essential during the short peak demand times in the morning (7-9 am) and evening (4-6 pm). Drivers get an ample opportunity to rest during the off-peak hours.

The daily utilization of buses in Cleveland is shown in Figure 21. (Reference 20). As with most urban systems, the size of the fleet and the number of drivers is determined by the capacity requirements of the morning peak load. To handle the morning and evening peaks, many drivers

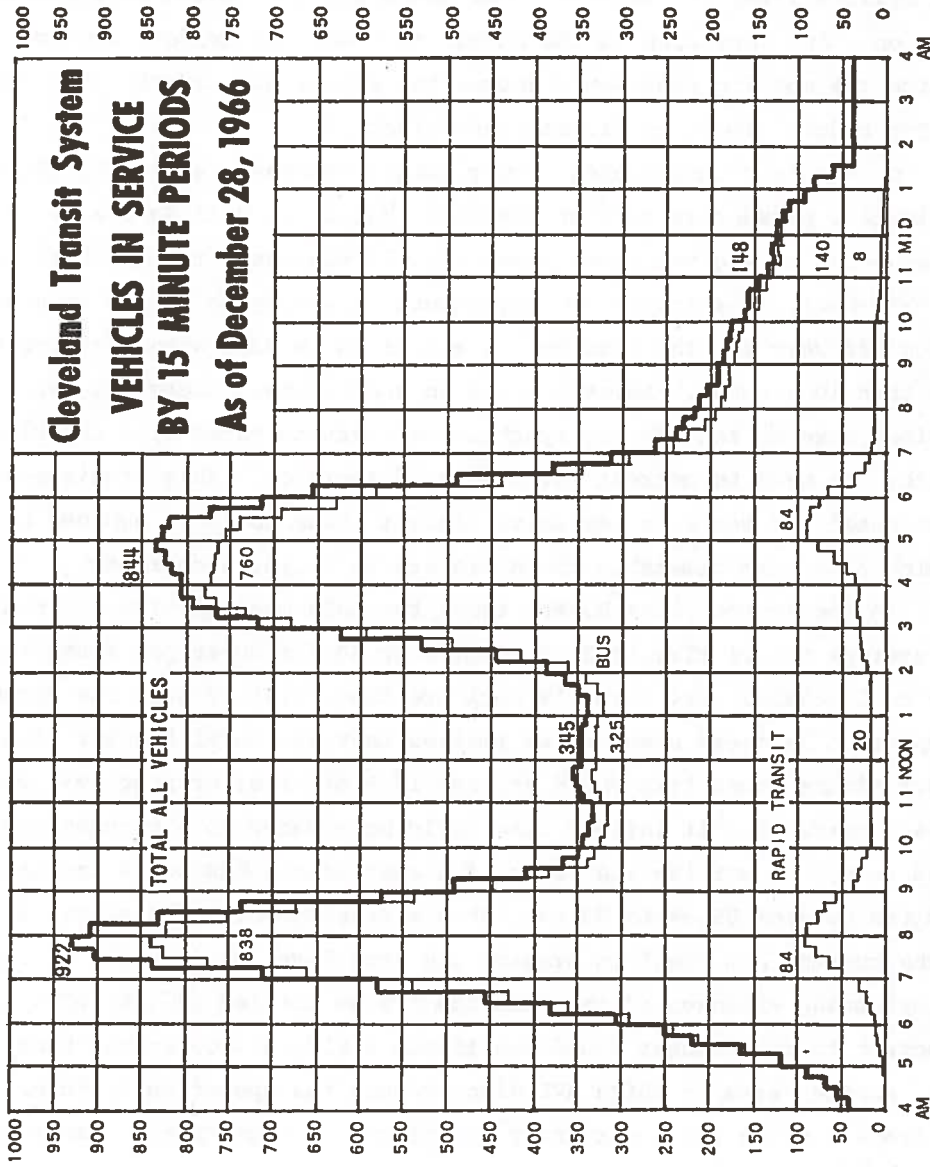

Figure 21. Transit Equipment Requirements, Cleveland, 1966

work split shifts, for example, four hours on, four hours off, and four hours on. Any reduction in the number of buses and drivers required to service the morning peak would reduce the entire bus transit system operating budget almost in direct proportion.

On the less busy routes having longer headways, e.g., 20, 30, and 60 minutes, passengers rely on the fact that a bus will pass a given pickup point at a given clock time, say, 13 minutes after the hour and the half-hour. Service is too infrequent to simply go to the stop at random and wait for the next bus to appear as is done when headways are less than 10 minutes. Layover times on such routes, therefore, are determined more by the need to synchronize starting times with the clock than by the need to correct for headway dispersion. This requirement, which sometimes leads to excessive layover times, could be avoided by issuing a printed timetable to passengers utilizing each route.

In the Metropolitan Boston area, the MBTA operates 199 bus routes; the average travel time is 21.6 minutes or 43.2 minutes per round trip with no layovers. Mr. Barber's estimate that 24.4% of each bus cycle is spent on layovers system-wide implies that the total layover time on a 43.2 minute round trip would average 13.9 minutes, or roughly 7 minutes at each terminal. If layover time could be reduced to 5 minutes per round trip, the utilization factor for each active bus would increase from the present 75.6% to 89.6%. Such a development would permit 84% of the current bus fleet to provide the same level of service. In 1975, the operating expenses of the MBTA bus system totaled \$86,180,000; a 16% reduction in this budget would constitute a \$13,789,000 annual benefit.

Another area in which AVL might reduce the operating expenses of bus transit is in the supervisory functions. A significant number of transit employees work as starters, pointmen, mobile supervisors, and dispatchers whose principal task is to keep the buses on schedule. In the MBTA system, schedule checking is primarily the responsibility of 149 starters, stationed at the principal terminals, and 5 traffic checkers. Other field forces like the barn supervisors and mobile inspectors, are mostly occupied with trouble shooting. In recent years, budgetary restrictions have reduced the number of en-route checkers or pointmen



drastically in all transit systems. In 1952, for example, the Chicago Transit Authority employed 400 mobile and stationary supervisors, but by 1973, only 208 were employed to monitor 2350 buses on 135 routes. With centralized monitoring of bus positions via data link and computer-aided headway control, it is probable that the performance of bus transit systems with respect to schedule adherence could be greatly improved and that the field personnel now responsible for this function could be replaced by a small number of centrally-located dispatchers. If these dispatchers exercise control-by-exception, i.e., only concern themselves with off-normal situations, and if the drivers themselves are given periodic updates on their headway or schedule deviations, so that they can initiate corrections, we estimate that a single dispatcher might be able to supervise up to 120 vehicles. If this estimate is correct, a total staff of about 30 dispatchers would be adequate to handle the MBTA's 1200 active buses around the clock. With centralized control, therefore, the 154 starters and traffic checkers used at present by the MBTA could be replaced by 30 dispatchers, a net reduction of 124 employees. At \$25,000 per employee (salary, fringe benefits, etc.), this reduction represents an annual benefit of \$3,100,000.

Driver and passenger security is a third area in which AVL techniques would yield benefits. Activation of an emergency button in the vehicle would alert the police department to the problem (robbery, assault, medical emergency, vandalism, etc.) and would pinpoint the exact location of the bus originating the alarm. The previous discussion of police response times indicates that assistance to the driver might be provided, on the average, about 3 minutes after he activates the alarm.

Over the 1972-74 period, there were 462 cases of assault on MBTA drivers that resulted in Workman's Compensation awards (medical expenses, sick leave, etc.) and, on some Boston routes at that time, drivers were refusing to operate without a police escort. Many less serious incidents are never reported. Dandrea (Reference 27) has estimated that in 1974 assaults and vandalism in the bus system cost the MBTA about \$365,000. A far more important effect, however, is that the perceived

level of risk influences the operators' pay scale. If they feel that they are in physical danger, the drivers will, quite properly, demand a level of compensation commensurate with the risk. Another major factor is the effect of violence or rowdyism on transit patronage. Anyone who considers the bus or subway system unsafe, most likely will resort to another travel mode, regardless of the cost or extra inconvenience. These factors cannot be quantified, but they are real and they are important.

As in the case of the taxicab fleet, bus drivers can be trained to serve as a police auxiliary, reporting crimes-in-progress, suspicious activity, accidents, wanted persons, etc. Two-way radio communications with the dispatch center or, perhaps, with the police department directly, would be essential to discharge this function properly.

Dandrea (Reference 27) has identified other secondary benefits that would accrue to the MBTA from installing two-way voice/digital communications equipment in the entire bus fleet and a central communications processor. In brief, these benefits are derived from making more accurate and comprehensive on-line data available to the MBTA management regarding passenger loading, trip times, maintenance problems, schedule adherence, and bus availability. Much of the data required for periodic schedule updates, according to Dandrea, could be collected automatically with such a system instead of sending traffic checkers to each loading point to record data manually. The result would be more efficient schedules and better utilization of vehicles and drivers. The allocation of costs among the 79 towns and cities included in the MBTA area is also determined, in part, by passenger counts and Dandrea's proposed system would provide more accurate inputs to that process.

What are the functional requirements for an urban bus transit system like the MBTA? With respect to AVL accuracy, the dominant factors appear to be headway control and the ability to locate a vehicle in the emergency state quickly. Taking the Dudley-Harvard schedule as typical (3.7 miles in 25 minutes), buses average about 9 mph or 790 feet per minute. Only three of the MBTA's 199 routes have rush hour headways less than 5 minutes; 5 to 15 minute headways are more representative of the busiest routes. At

9 mph, a 5 minute headway is equivalent to a 3950-foot spacing between successive buses. For control purposes, the error in vehicle positions should be no greater than 10% of the nominal spacing, i.e., a CPE (95% confidence) of about 400 feet is indicated. Based on previous discussions of police and taxicab requirements, this accuracy is also adequate for locating a vehicle in trouble in a highly-developed downtown area.

Update requirements are not severe in a fixed-route bus system as long as successive vehicles in a bus string are updated at approximately the same time. The relative positions determine what control actions, if any, must be taken to correct headway or schedule deviations. Periodic position updates of, say, one per minute should be adequate for this purpose. A vehicle in the emergency state, however, should be polled more frequently. The area covered by the MBTA system is 1022 square miles.

In summary, the application of AVL and digital data link techniques to fixed-route bus control and monitoring appears to be cost effective. For example, if the per-vehicle costs were \$3000 and the central processing and control facility were to cost \$2,000,000, the total capital investment for the MBTA's 1200-bus system would be \$5,600,000. Such an investment would be recovered in less than a year by the 16% reduction in the number of peak-hour buses and drivers required. The key question, which must still be answered by an experimental demonstration, is whether a practical headway control system can be devised which will actually permit such a reduction. Headway control utilizing AVL information has been attempted in the transit systems of Hamburg, London, Paris, Zurich, and Chicago. The only significant data available to us concerning these installations, however, is from the Hamburg operation (1152 buses, 24 routes). The headway deviation there was reduced by 50% and 25 reserve buses were eliminated because of the improved regularity of the service.

Within the next two to three years, a major demonstration of the application of AVM techniques to transit and para-transit fleets is planned in the Los Angeles area by the Urban Mass Transportation Administration (Reference 43). This experiment, involving the monitoring and control of 225

buses of the Southern California Rapid Transit District operating on fixed and random routes, will be extended in time to include a limited number of other vehicles such as police patrols, delivery trucks, and taxis. A 1972 UMTA experiment for improving schedule maintenance and safety on 60 fixed bus routes of the Chicago Transit Authority was unsuccessful because of a large number of reliability problems with the equipment utilized, which although eventually solved, adversely affected the results (Reference 44).

Prior to awarding the Phase II contract for the design, development, and deployment of the Los Angeles multi-user AVM system, a preliminary Phase I evaluation of four competing vehicle location sub-systems was conducted in Philadelphia in early 1977. The candidate systems were Loran-C (Teledyne), RF signposts (Fairchild and Hoffman), and pulse tri-lateration (Hazeltine). The objective was to ascertain that the vehicle location technique chosen for the Los Angeles experiment would operate satisfactorily and within specifications in an urban environment. The results of this competitive evaluation have been published by the D.O.T. Transportation Systems Center, and are discussed in Section 3.2 (page 98). An earlier comparison test of competing AVM technologies was conducted in Philadelphia in 1971 under UMTA sponsorship, and is documented in References 45 and 46. The 1977 Philadelphia tests are described in Reference 59.

2) Dial-A-Ride Bus Control. The main purpose behind the Dial-A-Ride concept is to provide the door-to-door service characteristics of taxicabs at a fare that approaches public transit fares. Lower costs per passenger result from the fact that several persons can share the vehicle at the same time. It is assumed that the demand will be sufficient in the area served to create coincident trip origins and destinations that can be satisfactorily accommodated by a set of piecewise-linear vehicle paths. If such is not the case, Dial-A-Ride reduces to ordinary taxi service, but with higher-than-ordinary taxi expenses.

In the original concept analysis carried out at M.I.T. (References 30, 31), it was concluded that "Dial-A-Ride does not require an AVL system to make it viable, but such a system would increase the efficiency by an average of 10 percent for all system sizes. That is, the same level of service could be provided with 10% fewer vehicles." Without AVL, the scheduling system only knows each vehicle's exact position when the driver reports via data link that he has picked up or dropped off a passenger. Between reports, the system merely knows that the vehicle is in transit between the last pickup/dropoff point in sequence. If the distance between successive points is small, i.e., the trip demand density is high, the uncertainty with respect to vehicle positions is not great. However, if the distance between successive points is large, significant errors in estimating a vehicle's position are possible, e.g., it makes a great deal of difference whether the vehicle first proceeded East-West or North-South on the street grid in travelling to the next pickup/dropoff point. When a vehicle must be selected by the dispatch computer to provide service to a new origin-destination pair, position errors may result in the assignment of a bus which is not closest to the pickup point, thereby generating excess mileage. On other occasions, the assignment may cause a vehicle to back-track, which annoys the passengers already on-board.

According to Professor Nigel Wilson of M.I.T., the Rochester Dial-A-Ride Demonstration Project has encountered a lower demand density than expected and, as a consequence, the average distance between successive

pickup/dropoff points is greater than anticipated (1.5 miles). Furthermore, drivers are quite casual about when they transmit a pickup or drop-off signal to the dispatch computer via data link, and this adds to the uncertainty in vehicle positions. In Professor Wilson's opinion, it is virtually impossible to effect a rendezvous between a Dial-A-Ride vehicle and a fixed route bus for transferring passengers without AVL position information.

A 10% reduction in the number of vehicles required to provide a given level of Dial-A-Ride service would be a more than adequate justification for installing AVL equipment in the DAR fleet. Assuming a 5-year amortization period at 7% interest and an annual maintenance expense equal to 5% of the initial capital investment, a \$1000 installation of AVL equipment in one vehicle would result in a \$295 annual charge for 5 years. The cost per vehicle-hour for operating a Dial-A-Ride bus has been estimated as \$12.50 (Reference 30), hence the cost for one full year of operation for one bus (12-hour day) would be \$54,750. Therefore, if a fleet of  $N$  vehicles were to adopt AVL, 10% of the fleet could be retired at an annual saving of \$5475  $N$ , but the installation of AVL equipment in the remaining 0.9  $N$  vehicles would result in a yearly expense of  $(.9 N) (295)$  or \$266  $N$ . The benefit-to-cost ratio of utilizing AVL in a Dial-A-Ride bus fleet, consequently, is twenty, a reasonable investment by any standard.

No study, to our knowledge, has been done on the accuracy requirements of AVL in a Dial-A-Ride system. The accuracy should be sufficient to minimize the assignment of wrong buses to calls, to avoid back-tracking, and to locate the vehicle quickly if the driver transmits an emergency signal. In the police and taxi applications, we have seen that the latter is the most stringent requirement, leading to a C.P.E. specification of 400 feet (95% confidence). On the basis of his simulation studies and the Rochester experiment, Professor Nigel Wilson believes that a 600-foot accuracy would be adequate for DAR bus scheduling. Position information is not critical until a new origin-destination pair must be assigned, and, even then, only the potential candidates for the assignment need to

be located exactly. At other times, an overall fleet update period of one minute would be acceptable.

Dial-a-Ride AVL coverage areas would vary from small cities to metropolitan areas such as that served by the Massachusetts Bay Transportation Authority (79 cities, 1022 square miles). The DAR experiment currently being run by the Rochester Regional Transit Service operates in two selected areas:

- a) Greece - population 55,000 - area 10.2 square miles
- b) Irondequoit - population 48,500 - area 11.6 square miles

Other DAR experiments have been conducted in Haddonfield, N.J. (12,500 population, 11 square miles, 10 buses), Santa Clara County (1,150,000 population, 200 square miles, 40-75 buses). Numerous variations of demand-responsive transit have also been implemented (Reference 30), including over 50 small, manual Dial-A-Ride systems. In spite of all the activity on DAR demonstrations, the most critical question is not whether AVL should be included as part of a Dial-A-Ride installation, but whether Dial-A-Ride itself is a viable transit concept.

It is obvious from the declining patronage and growing operating deficits over the last 30 years that classic transit (rail rapid and buses) is at a competitive disadvantage relative to the automobile trying to serve the dispersed origin-dispersed destination trips characteristic of today's metropolitan areas. It is also obvious, however, that the dominance of the automobile in urban travel leads to some undesirable side effects, e.g., excessive energy consumption, rush-hour traffic jams, air pollution, a large number of accidental injuries and deaths, a disproportionate allocation of urban space to roads and parking facilities, and the exclusion of a significant portion of the population who are non-drivers. The young, the aged, the poor, and the disabled lack adequate access to an automobile. Furthermore, if the family car is used to transport one member to work, other licensed drivers in the family are deprived of its use during that member's absence.

Nonetheless, unless a trip origin and destination are in the vicinity of rapid transit lines, the automobile is almost certainly the fastest and most convenient mode for any given urban trip. The average cost of operating a private automobile in an urban environment (fuel, insurance, depreciation, maintenance, etc.) is about \$1500 per year or \$4.10 per day. Referring to the results of a comprehensive measurement of trip making in the Eastern Massachusetts Regional Planning Project shown in Table 2 (Reference 17), we note that the 1,070,000 automobiles in the region were involved in 4,440,000 vehicle trips, i.e., the average automobile went on 4.15 trips per day. At the current cost of car ownership, therefore, one vehicle trip represents an expenditure to the owner of about \$1.00. On trips to the urban core, there is an additional expense of \$1.50 to \$2.50 for parking. Rapid transit and bus fares in the immediate Boston area are both set at \$.25 per ride, so it would appear that transit has a distinct price advantage over the car, especially on trips to the core area. In fact, however, the fares collected by the MBTA contribute only 25% of the total cost of operating the system. Including public subsidies, the true cost of a one- or two-mode trip by transit is \$1.00 to \$2.00, which is comparable to the average cost of an automobile trip.

The precipitous increase in fuel prices in recent years and greater concern over energy consumption and the degradation of the urban environment have created an urgent requirement for innovations that will make the transit modes more competitive with the automobile, especially in the critical area of trip time. In general, if transit time is equal to automobile time, transit will get about half the trips, but if transit takes more than 50% longer than the automobile, transit will only attract customers who have no other choice. Refer to Figure 20 in the preceding section, which shows the effect of travel time ratios (transit trip time divided by automobile trip time) on the modal split between cars and transit as estimated in eleven different studies.

In spite of the need for viable alternatives to the car, Dial-A-Ride experiments, such as Rochester, have not yet established that this



Table 2  
 Weekday Person Trips in Eastern Massachusetts  
 Regional Planning Project (1964 Measurements)

	<u>Number</u>	<u>Percent of Total Person Trips</u>
<u>Internal Person Trips</u>		
Auto Driver	4,444,000	45.8
Auto Pass. (Occupancy 1.43)	<u>1,907,000</u>	<u>19.7</u>
Auto Internal Total	6,351,000	65.5
School Bus Passenger	364,000	3.8
Subway/Streetcar Pass.	438,000	4.5
Bus Pass.	565,000	3.8
Train Pass.	<u>53,000</u>	<u>0.5</u>
Transit Total	1,420,000	14.6
Truck Passenger	11,000	0.1
Truck Driver	875,000	9.1
Taxi Driver	190,000	2.0
Taxi Passenger	<u>69,000</u>	<u>0.7</u>
Internal Person Trip Total	8,916,000	91.9
<u>External-Internal Person Trips</u>		
Auto Driver	325,000	3.3
Auto Passenger (Occupancy 2.1)	<u>357,000</u>	<u>3.7</u>
Auto External-Internal Total	682,000	7.0
Truck Driver External-Internal Trips	<u>38,000</u>	<u>0.4</u>
External-Internal Person Trip Total	720,000	7.4
<u>Through Person Trips</u>		
Auto Driver	27,000	0.3
Auto Passengers (Occupancy 2.45)	<u>38,000</u>	<u>0.4</u>
	65,000	0.7
Truck Driver through Trips	<u>3,000</u>	<u>Neg.</u>
	<u>68,000</u>	<u>0.7</u>
Total Person-Trips in EMRPP Area (Avg. weekday)	9,704,000	100

technique can compete with the private automobile with respect to travel time, convenience, and cost. Wilson has presented some preliminary results for tests last year in the Greece sector involving 7-9 computer-dispatched vehicles (Reference 32). After three months of testing and software refinement, the average wait time for customers demanding immediate service was reduced to 23.4 minutes and the average ride time was 18 minutes (Total time 41.4 minutes). For customers who called in advance to be picked up at a specific time, the deviation from the desired pickup time was 7 minutes (Std. Deviation). At the end of the test period, daily ridership was up to 462 and vehicles were averaging 5.1 passengers per hour. In previous testing under manual control, the DAR system had carried a peak daily load of 1000 passengers. Originally, fares had been set at a flat \$1.00, but, in later experiments, a graduated fare scale based on zones was introduced (\$.75, 1.25, and 1.75).

To assess the effect of a higher demand density, a one-day test was run in September, 1976, with demand artificially augmented by a group of volunteer riders. During the two-hour peak period, in which 133 passengers were served, vehicle productivity increased to 9.8 passengers per hour, but wait times for immediate-service customers averaged 35.4 minutes and ride times were 22.9 minutes on the average (Total 58.3 minutes). Perhaps even more discouraging was the large dispersion in pickup times (11.4 minutes), i.e., the time interval between a request for service and pickup, from the customers viewpoint, was unpredictable and, in that sense, the system was considered unreliable. At the present time, pickup delays have been reduced to about 18 minutes (average), but vehicle productivity remains at a low level (5 passengers per hour). Dial-a-Ride service now operates 8 hours per day in both the Greece and and Irandequoit test sectors using only 3 to 5 vehicles in each sector. Subscription service, however, is available 12 hours per day. Bus speeds average 16 mph. including the 5 to 10 stops per hour made by each vehicle.

The question of primary interest in our study is whether the Dial-A-Ride transit mode is to be taken seriously as a potential user of AVL techniques. The failure of the Santa Clara DAR experiment (Reference 33) and the marginal performance of both the Haddonfield and Rochester DAR experiments (References 30,32) indicate that Dial-A-Ride, as presently conceived, is not a practical transit alternative. However, after examining the evidence, we have concluded that, with appropriate operational, institutional, and marketing changes, a viable para-transit mode could be developed which might attract up to 30% of the trips made in most urban areas. This mode would accommodate and integrate all of the following trip formats:

1. Many-to-many (private), i.e., taxi
2. Many-to-many (shared ride) i.e., Dial-A-Ride
3. Many-to-one (shared) where the destination might be a school, a place of work, a shopping center, a rapid transit station, a special event, a child care center, a medical care center, a senior citizen center, airport, etc.
4. One-to-many (shared) inverse of item 3
5. Fixed Route Bus Service
6. Rail Rapid Transit Trunk Lines
7. Delivery of Parcels, Documents, Letters, Etc.

The ultimate test of such a system would be its performance relative to the automobile; as shown in Figure 20, a travel time ratio of about 1.2 would be required to divert 10 to 30% of the car trips to transit under various circumstances. The Rochester Dial-A-Ride mean level of service objective (2.5) was quite inferior to this, hence that system attracted less than 1% of all person trips within the Greece sector. [Note: mean level of service is defined as the mean of the system service time divided by the mean direct driving time]. Reliability of service is almost as important as trip time in attracting customers. Specifically, dispersion in scheduled pickup times should be of the order of one minute and waiting times for immediate service customers should consistently be 5 to 10 minutes or less.

That part of the system which operates in the many-to-many or many-to-one mode should be organized as a taxicab, not as a transit, service, with the driver's compensation being proportional to fares collected. Fares, in general, should vary with the type of service provided, e.g., a many-to-many (private) ride would cost considerably more than a many-to-one (shared) ride. The many-to-many services do not appear to be economically feasible unless vehicle operating costs are approximately equal to that achieved in the taxicab industry (\$6.00 per vehicle hour). This figure includes the driver's compensation, of course, and it would not be possible at transit pay scales.

In any given urban area, the natural inclination would be to start with a limited number of vehicles operating in the paratransit mode and to expand the fleet size gradually with increased public demand for service. Unfortunately, because of the enormous trip-making activity in all metropolitan regions, there is always the danger that the initial fleet will be overloaded immediately, causing the level of service to degrade and potential future customers to become prematurely disenchanted with the capabilities of the system. The collapse of the Santa Clara DAR experiment was a classic illustration of an insurmountable start-up problem (Reference 33). The Rochester experiment is a less hopeless situation, but it, also, is a good example of the double jeopardy in which small scale transportation innovations are placed. If the service offered is too good, too many people will be attracted to it, the initial system resources will be overtaxed, the system performance will deteriorate, and the users will become alienated. On the other hand, if the service is bad to begin with, the innovation will be rejected by the public forthwith. It is virtually a no-win situation in which the strategy is to provide a service that is neither too attractive or too unattractive, price being an important factor in controlling its usage. To illustrate the problem, we examined the trip demand potential that existed in the Rochester-Greece sector prior to the start of the experiment there. The Rochester-Genesee Regional Transportation Authority estimated that the Greece test area generated 56,000 intra-city trips per day by all modes. The peak hour usually has about 8% of the daily

trip total, which in this case would be 4480 trips. The test area was 10.2 square miles, so the peak demand density was 439 trips per square mile per hour. Figure 22 shows the many-to-many simulation results obtained by Wilson in 1971 (Reference 31), with Greece data added (dashed lines). Wilson's results indicate that for the area of Greece, 18 vehicles would be necessary to provide a mean level of service of 2.5 if the demand density for DAR service were only 12 trips per hour per square mile (2.7% of the total demand density during the peak hour). Since only 5 to 10 DAR vehicles were available for the initial series of tests, it is clear that if more than about 1% of the intra-Greece trips had switched to Dial-A-Ride, the system would have saturated and levels of service would have deteriorated. Figure 23, also based on Wilson's simulation studies, shows that under conditions of a constant demand density (25 trips per square mile per hour or 5.7% of the total demand density during the peak hour), the number of vehicles required to improve the level of service goes up rapidly below a value of two. Fortunately, the vehicles are more efficient in carrying many-to-one or one-to-many passengers and a substantial percentage of the trips in Greece are in these categories. For example, two shopping centers generate roughly 33% of the intra-Greece trips, and Kodak Park, a very large industrial site, is located in Greece.

We have spent a great deal of time discussing the prospects of Dial-A-Ride and other paratransit modes mainly because such applications might well be the predominant users of AVL equipment in a metropolitan area. A quick estimate of the potential number of paratransit vehicles required to service the Eastern Massachusetts Regional Planning Project area, for example, was 12,000. Surprisingly, the number of taxis, MBTA buses, school buses, and private buses in the EMRPP area is already a substantial fraction of this figure.

In a recent article (Reference 42), Alan Altshuler, Professor of Political Science and of Urban Studies and Planning at M.I.T. and formerly Secretary of Transportation and Construction for the Commonwealth of Massachusetts points out that "the American political system

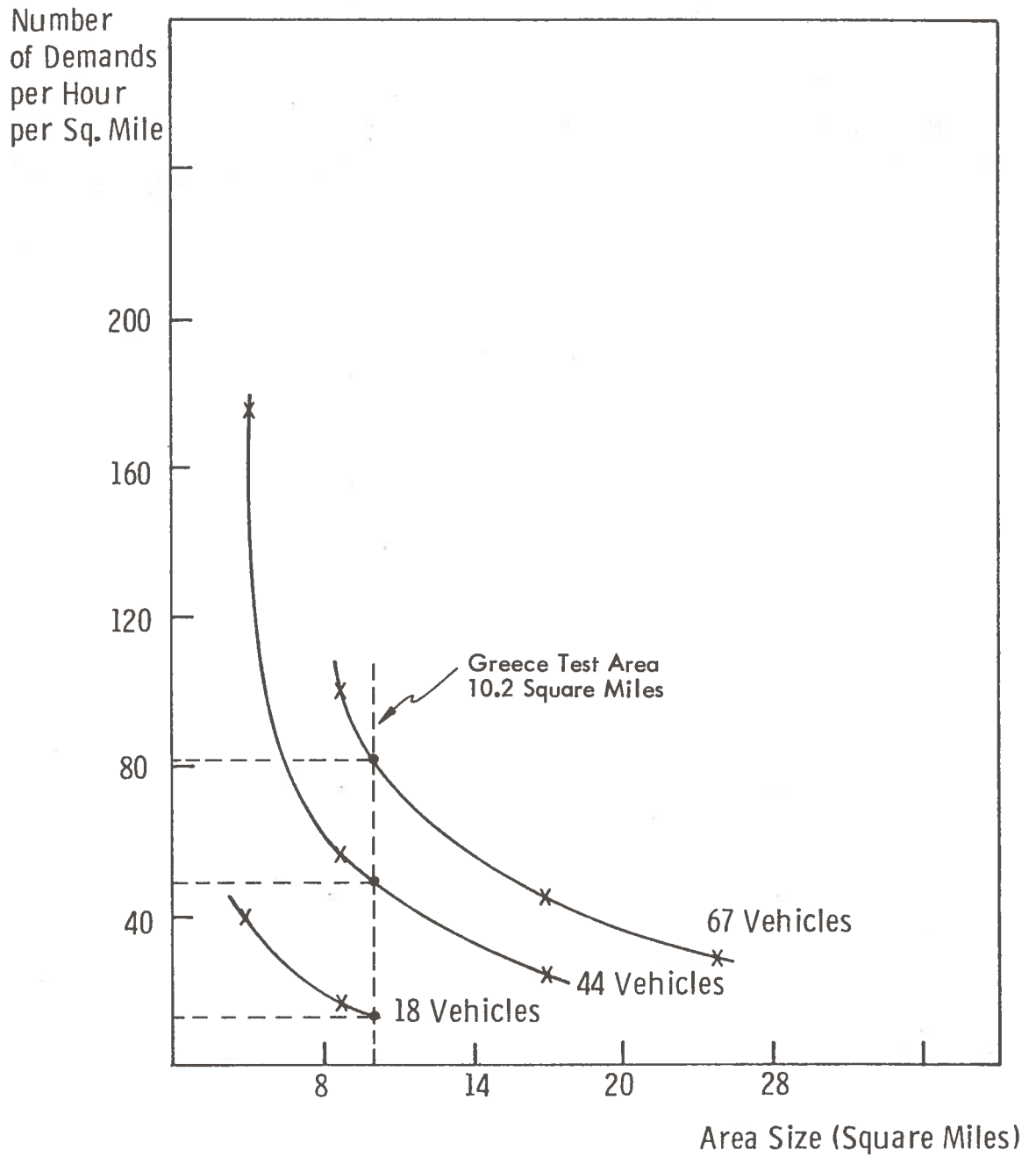

Figure 22 Relationships among Demand Rate, Vehicles, and Area (Many-to-Money DAR, Mean Level of Service 2.5)

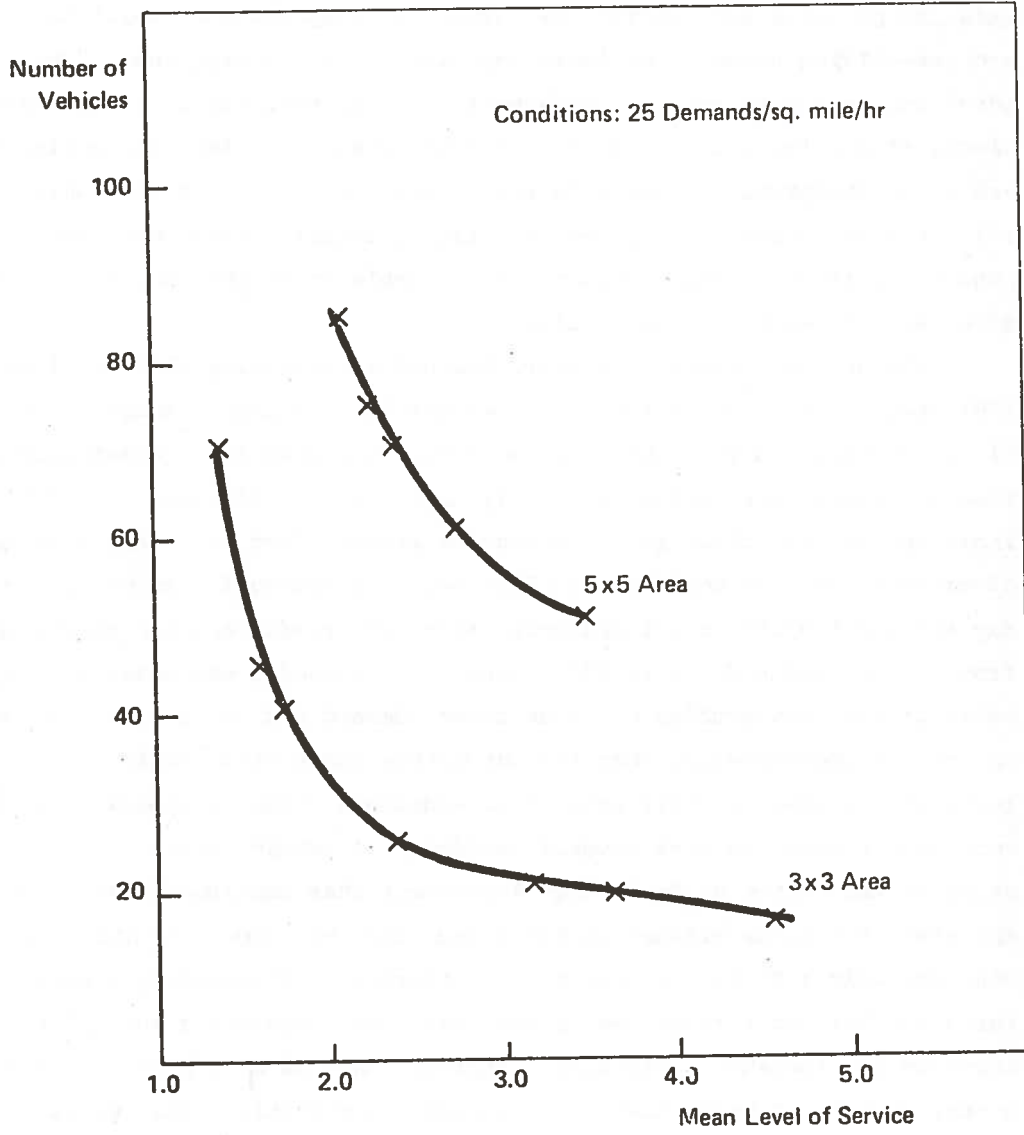

Figure 23 Relationships between Number of Vehicles and Level of Service (Many-to-Many DAR, 25 Demands/sq. mile/hr.)

strives, wherever possible, to accommodate new demands without disturbing existing policies and behavior patterns. This approach to political problem-solving tends to minimize conflict." As a consequence, "the ideal innovation is one that consumers will buy voluntarily in the market place, at a price high enough to cover its cost .... American politicians are drawn inexorably to technological innovation as a path to problem solving with minimal disruption of existing social arrangements and behavior patterns. Where technology is unable to do the job, the system often appears woefully ineffective."

The national transit industry has had an operating deficit since 1963 and, by 1975, the deficit had reached \$1.7 billion. Roughly 40% of all federal aid for urban transportation now goes for transit purposes. Federal transit assistance in FY 1977 totalled \$2.5 billion, a 19-fold increase over the 1970 level. Altshuler states, "Yet the transit share of urban travel has continued to decline. The automobile accounts today for about 97.5% of all passenger miles of travel in urban areas, up from 83% in 1950 and 93% in 1960. One can reasonably estimate, on the basis of numerous studies of urban travel demand and of consumer response to transit improvements, that the automotive share will remain at this level or increase slightly even if no additional highway capacity is constructed over the next several decades." Altshuler cites a recent study by the Office of Technology Assessment that concluded that doubling the transit vehicle mileage operated each day throughout the nation would generate only a 20 to 40% increase in ridership. Eliminating transit fares and holding service levels constant would generate a 50 to 70% increase in ridership. Altshuler concludes that if both policies were combined that, at best, transit patronage would double. This would only raise the transit share of urban travel to about 5% and it would entail a tripling of public spending for transit purposes by all levels of government. "Because of the growing sense of the limits of



conventional highway and transit programs, there has recently been an upsurge of interest in more innovative means of solving the problems of urban transportation." These include improved traffic management techniques, para-transit services such as dial-a-ride, regulatory measures to force the development of safer, less polluting, more fuel-efficient automobiles, and auto travel disincentives (gas and parking taxes, higher tolls, etc.). "Demand responsive transit services, efforts to promote carpooling and van pooling, and increases in conventional transit service coverage, however, seem likely to attract only very small numbers of patrons in the years ahead," according to Altshuler. There is a distinct possibility that Altshuler's last conclusion may be in error. The issue is sufficiently important that we have recommended in Section 5 that an urban test bed be set up to assess the ability of good paratransit service to divert trips from the private automobile.

#### 2.4 Emergency Medical Services

Functionally, the assignment of an ambulance to an emergency medical case is similar to the dispatching of police vehicles. Minimizing the time spent on the dispatch operation, the trip to pick up the victim, and delivery to an appropriate medical facility are of the utmost importance. Approximately 600,000 Americans die each year as a result of heart attacks and another 100,000 are killed in accidents. Many of these fatalities could be prevented by prompt medical attention. The arguments presented in the discussion of police command and control systems for push-button dispatching and AVL, therefore, are also applicable to ambulance command and control. The requirements for medical emergency and police dispatching are so similar, in fact, that it is clear that the two systems should be combined where possible. An integrated medical and police dispatch facility, in which both services share a common address data base and dispatch computer, is currently in operation in Boston. Often, of course, events like automobile accidents and fires require all three emergency services, police, fire, and ambulance. Coordination would be facilitated by the use of a single dispatch center and overall operational efficiency would be enhanced.

At first glance, it is not obvious that AVL would be a useful requirement for ambulances, since such vehicles are usually stationed at a specific location like a firehouse. In Boston, however, the Department of Health and Hospitals, not the Fire Department, is responsible for emergency medical services and the 8-12 ambulances on standby have no pre-assigned locations. Not infrequently, an ambulance that has just completed a run, but is still on the road, is the most suitable vehicle for a new assignment. To illustrate, the Emergency Medical service of the Watertown (Mass.) Fire Department recently answered five successive calls over a period of three hours without once returning to the firehouse. The new Federal Ambulance Specifications (KKK-A-1822, issued January, 1974) and more strict state supervision of emergency medical services (e.g., Massachusetts Ambulance Law and Regulations passed in 1973) have reduced the number of vehicles qualified to offer Class 1 emergency service. As a consequence, those vehicles which do meet the more stringent current requirements operate at a higher duty

cycle and are on the road a greater percentage of the time. The trend toward delivering patients directly to the hospital best equipped and staffed to handle their specific difficulty will tend to produce longer vehicle trips and more time spent on the road.

Perhaps the most compelling argument for equipping emergency vehicles with AVL, however, is the ability to exercise effective control over a large number of mobile units in the event of a major disaster such as an earthquake, plane crash, large-area fire, or act of war. Many vehicles from outside the afflicted area would be required to provide the necessary medical, fire and police services. The dynamic allocation of these resources as well as the control of local vehicles, would be greatly facilitated by up-to-date position and status information on each unit. Of even greater importance, however, would be the prior coordination of emergency communications so that effective disaster relief could be provided to all urban areas by the surrounding region.

As in the case of police operations, the use of AVL by emergency medical services is only practical as part of an integrated system with computer-aided dispatching and digital data communications. Information concerning each case should be entered as received by phone into the computer via a keyboard/display console. The computer could automatically check the validity of the address and maintain an up-to-date record of ambulance locations and status, and hospital locations, facilities, and status to assist in the choice of an appropriate point of entry for the patient. As soon as enough information is received to select the nearest available ambulance with the proper equipment and staff to handle the case, the medical dispatcher should have a push-button dispatch capability so that a vehicle can be sent on its way while he is recording the remaining data. Additional information will be received from "first responders" or from the ambulance crew after they have examined the patient, and this too should be incorporated in the computer file on the accident and made available to the hospital selected as the point of entry. Some agencies are even planning to telemeter patient data such as electro-

cardiogram signals from the ambulance en route to the hospital. The medical dispatcher should also have access to police and fire department support units and private ambulance services as backups for the first-line emergency vehicles. Because of the limited number of Class 1 ambulances available, the dispatcher's initial task might be to get a trained "first responder" to the scene quickly to attempt to stabilize the patient's condition before the arrival of the Emergency Medical Technicians in the ambulance. First responders are also helpful in evaluating an emergency situation first-hand, thereby assisting the dispatcher in assigning the proper resources. The first responder in many cases is a police officer, although with proper training, lifeguards, bus drivers, taxi drivers, and firemen could be equally effective in this role. There are many more police vehicles, buses, and taxis in a given metropolitan area than there are ambulances, hence, fast response times should be possible. In a survey conducted in 1973, the Massachusetts Department of Public Health found that only 196 of the 1092 vehicles used as ambulances in the State meet today's standards. At that time, 31 vehicles had direct radio communications with a hospital and less than one-third of the ambulances carried all nine essential pieces of equipment (suction, oxygen, resuscitation equipment, splints, long and short spine-boards, first aid and obstetric kits, and ambulance cot). Only 761 of the 13,000 ambulance attendants in the State were trained at the Emergency Medical Technician (EMT) level. The present objective of the Massachusetts Office of Emergency Medical Services is to have 9,000 trained EMT's to staff the Commonwealth's ambulance services and an additional 37,000 persons with enough first aid training to be classified as "first responders".

The situation has improved dramatically since 1973 due to a number of federal and state programs to upgrade ambulances, personnel training, communications, hospital emergency facilities, coordination between agencies, record keeping, and public awareness. To the outside observer, in fact, the parallel efforts in this field could themselves be coordinated more effectively. Both the Department of Transportation National Highway Traffic Safety Administration and the Department of Health, Education, and

Welfare (EMS Division) have programs to support emergency medical services at the state and local level. While the Law Enforcement Assistance Administration of the Justice Department is providing funds for centralized police dispatch facilities, the Department of Transportation is doing the same thing for fire and emergency medical dispatch facilities. The Coast Guard is responsible for EMS for vessels in coastal waters. The Federal Communications Commission exerts an indirect influence on efforts to coordinate emergency services by its power to allocate radio channels. Further overlapping of responsibilities exists at the state, county and local levels. Civil Defense, National Guard, and military organizations are active participants in disaster relief planning.

#### 2.5 Aircraft Movement on an Airport Surface

The advent of Category 3 landings and takeoffs requires, as a prerequisite, a method of navigating aircraft and avoiding conflicts on the airport surface under Category 3 visibility conditions. The prevention of conflicts between aircraft on the ground, of course, has always been a primary ATC objective. We believe that two of the AVL techniques discussed in this report, multilateration and Loran-C, can satisfy the surface navigation requirements of aircraft in restricted visibility and that it is appropriate to include this application in the evaluation of AVL costs and benefits.

The prevention of conflicts on the airport surface is a classic AVL problem. The tower controllers require a real-time map display showing the positions of all moving vehicles on the taxiways and runways in order to direct traffic effectively under restricted visibility conditions. Of particular importance is keeping the active runways free of vehicles during landings and takeoffs. A number of serious accidents have occurred in recent years (Chicago O'Hare, Boston Logan, Canary Islands Tenerife, Tel Aviv, etc.) involving takeoffs on an obstructed runway. Under Category 1 (220 ft. ceiling, 2600 ft. visibility), Category 2 (100 ft. ceiling, 1200 ft. visibility), and Category 3A (visibility 700 ft.) conditions, pilots can detect nearby aircraft and vehicles visually, so a location accuracy specification of 400 feet (C.P.E. 95%)

would be entirely adequate. However, under Category 3B conditions (150 ft. visibility), they would have to rely primarily on AVL data displayed in the cockpit for conflict avoidance and general guidance on the taxiways. As can be seen in Figure 24, the taxiway network of a major terminal such as Kennedy is complex and it would be rather easy to get lost under Category 3 conditions. In Category 3C (zero visibility), the pilots would be totally dependent on AVL information for collision avoidance, for surface navigation, and even for keeping the wheels of the aircraft on the taxiway. A typical taxiway is only 75 feet wide, whereas the wheel spacing on a 747 is 36 feet. Taxiway tracking, therefore, would require an AVL accuracy of less than 20 feet C.P.E. (95%). This is by far the most stringent accuracy specification on AVL that we have encountered, comparable to the requirements for the navigation of vessels on certain inland and coastal waterways.

A major element of the FAA's future Upgraded Third Generation ATC System is an all-weather capability for surveillance, guidance, and control of aircraft on the airport surface. Since 1972, the D.O.T. Transportation Systems Center has been engaged in an effort to specify, design, and develop new equipment to satisfy the FAA requirements. For surveillance, TSC has selected the Bendix Geoscan technique which employs ATCRBS transponder replies from aircraft and multiple, fixed receivers for accurate position location and vehicle identification. Two or more phased-array antennas must be installed at each airport so that aircraft can be interrogated individually and located by trilateration from their replies. The cost of a complete system, including four Geoscan antennas, displays, and computer, suitable for a major airport has been estimated as \$600,000. It is probable that a LORAN-C minichain in each major metropolitan area could be used to locate aircraft with comparable accuracy on an airport surface, position data being sent via data link from the aircraft to the tower. Since the chain could also be utilized by other agencies (police, ambulance, busses, etc.), this solution to the surface surveillance problem appears to be more cost-effective than the special-purpose Geoscan system selected by TSC.

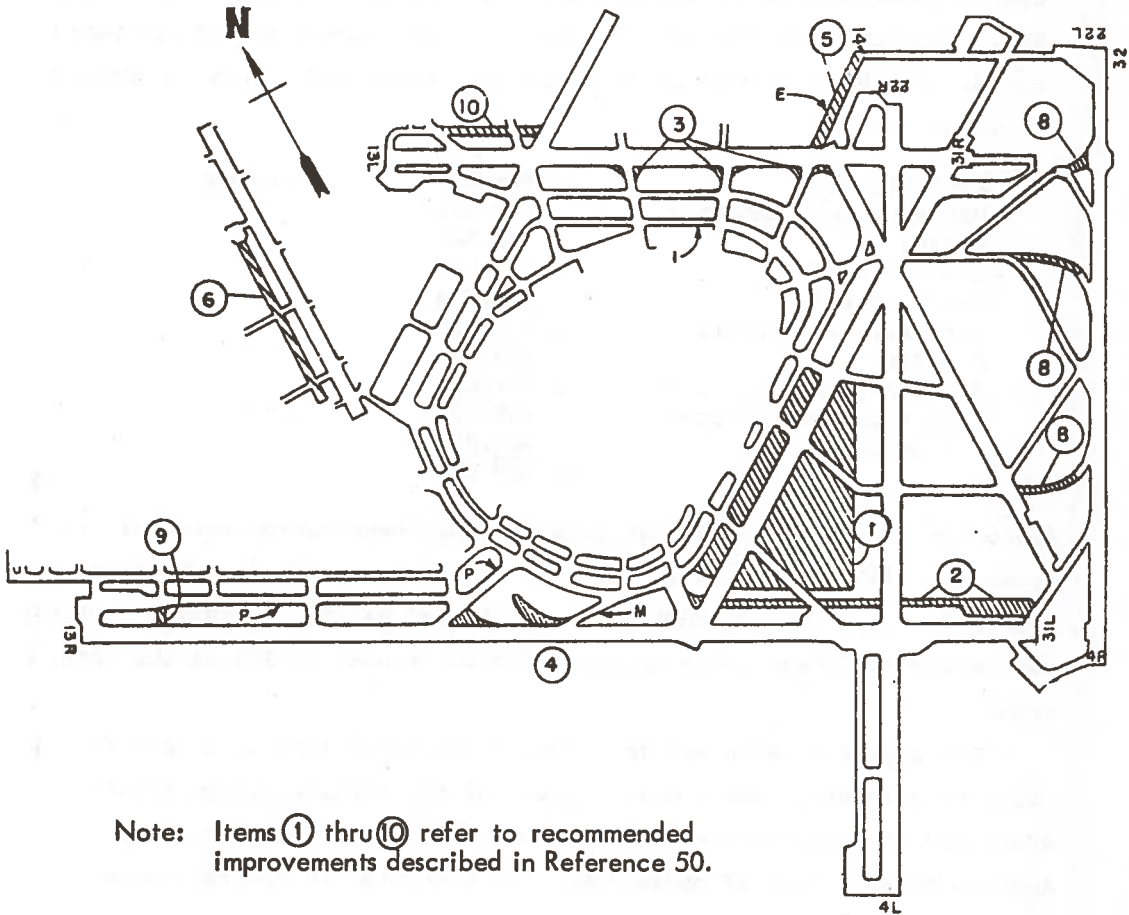

Figure 24 Taxiway Network -- Kennedy Airport

## 2.6 Truck Dispatching and Security

In 1972, there were 19,747,000 trucks in operation in the United States generating about 245 billion truck-miles of travel (Reference 56). All but 5,283,000 of these vehicles were small pickup and panel types. As the breakdown below indicates, there was a great diversity of uses:

Agriculture	4,258,000	trucks
Forestry and Lumbering	187,000	"
Mining	77,000	"
Construction	1,693,000	"
Manufacturing	443,000	"
Wholesale and Retail	1,875,000	"
For Hire	770,000	"
Personal Transportation	8,122,000	"
Utilities and Services	1,995,000	"
All Other	<u>327,000</u>	"
	19,747,000	

Since the discussion of AVL applications has centered on metropolitan areas, we will only consider the user categories which are characteristically urban (Manufacturing, Wholesale and Retail, For Hire, Utilities, and Service). These users employ 5,083,000 trucks or 26% of the total truck fleet.

The approach taken was to survey truck operations in a specific urban area (Boston) which were typical of the various categories of users and to evaluate the potential benefits of an AVL capability applied to each mode of operation. The benefits, in general, were of three types:

- 1) More efficient use of trucks and manpower
- 2) Security
- 3) More effective supervision of drivers

The economic profile of the trucking industry as a whole can be indicated by a few general statistics (Reference 56). Of the 2071 billion ton-miles of domestic intercity freight carried in 1972, 22.7% was carried in trucks compared to 37.8% by rail, 16.3% by inland



waterways, 23% by pipeline, and .2% by air. However, motor carriers of property regulated by the Interstate Commerce Commission, which handled only a fraction of the highway ton-miles cited above, generated operating revenues of \$18.7 billion in 1972. In contrast, the operating revenue of railroads was just \$14.15 billion, of water carriers \$.55 billion, and of pipelines \$1.34 billion. The operating revenues of motor carriers of property with a payroll and not subject to ICC regulation (local and intra-state carriers and carriers of certain exempt agricultural commodities, fish, etc.) was \$7.8 billion. About 100,000 long-haul trucks are operated by independent owner-drivers, most of whom hire themselves out to the big, government-regulated freight companies and haul whatever they are assigned. About 20% of the independents however, are involved in produce hauling. It is estimated that the independents are responsible for about 40% of all inter-city truck traffic. In addition, of course, there are a large number of trucks operated by private firms which are not for hire, but which are employed in the movement of inter-state and local freight associated with the organization's business. When this category of trucks is included, the nation's highway freight bill for 1972 probably totalled about \$65 billion. Some 1,085,000 people were employed in trucking and warehousing in 1975, 41.7% of the total direct employment in the transportation industry.

The Class 1 motor carriers dominate the segment of the industry under ICC regulation. The 1525 carriers placed in this category in 1972 generated 80% of the operating revenues collected by the 15,000 Class 1, Class 2, and Class 3 firms. The Class 1 fleet in 1972 had 56,000 trucks, 148,000 truck tractors, and 327,000 trailers. At the other extreme, the 62,924 for-hire establishments with a payroll and not subject to ICC regulation were predominantly small, local firms engaged in the following activities.

<u>Activity</u>	<u>Number of Establishments</u>	<u>Operating Revenues (Millions)</u>
general freight	10,947	\$1,692
household goods	7,891	987
sand and gravel	10,661	1,269
trash and garbage collection	8,292	945

<u>Activity</u>	<u>Establishments</u>	<u>Operating Revenues (Millions)</u>
package or parcel delivery	1,410	\$ 155
agricultural products and other ICC exempt commodities	10,812	1,182
mail, contract	2,685	200
timber	1,878	192
other commodities	8,348	1,171
	<u>62,924</u>	<u>\$7,793</u>

Two Class 1 common carriers serving the Boston area, McLean and St. Johnsbury, were contacted to determine if any aspect of their operations might benefit from an AVL capability. Both firms have a local terminal where freight picked up in the region is collected and loaded onto their long-haul trucks. Conversely, inter-city freight dropped off at these terminals is transferred to local delivery trucks and distributed throughout the metropolitan area. St. Johnsbury, the biggest carrier in New England, has 75 to 100 radio-equipped pickup and delivery trucks operating out of its Cambridge terminal and servicing the entire Eastern Massachusetts region. According to Mr. Collins, the manager of the terminal, about 75% of the local truck stops are pre-scheduled and the remaining 25% result from customer pickup calls during the day. In the latter cases, AVL would enhance efficiency by enabling the dispatcher to assign the nearest truck to each pickup. The line-haul trucks operate, for the most part, on a regular schedule along an ICC-authorized route from terminal to terminal. Their position in transit can usually be estimated with reasonable accuracy on the basis of their departure time from the previous terminal. St. Johnsbury takes special precautions with high-value cargoes, such as providing an escort, and hijacking has not been a serious problem for this firm.

McLean is a large Class 1 common carrier with extensive operating rights in North and South Carolina and the northeast quadrant of the United States. It operates over 65 freight terminals. The one located in Stoneham, Mass. serves the Metropolitan Boston area with a fleet of 46 pickup and delivery trucks, all but 9 of which are radio equipped. Mr. DiSantis, the manager of the Stoneham terminal, estimated that less

than half the truck pickups each day are prescheduled and that knowing the location of the vehicles would help the dispatcher to select the best truck for a given pickup. At one time, the McLean dispatchers tried to keep track of truck locations via voice reports on the radio channel, but this task became too burdensome as the fleet got larger and systematic monitoring was discontinued. Mr. DiSantis was especially enthusiastic about the use of AVL to provide more effective supervision of drivers. They are on their own and scattered over the entire Metropolitan Boston area. The company is very vulnerable to employee abuses, which can cut productive effort by up to 50%. According to Mr. DiSantis, automatic vehicle location is a capability which is "sorely needed" in the trucking industry. McLean protects high-value loads by having the driver report his status to the dispatcher at regular intervals. At present, hijacking does not appear to be a major problem for this firm.

To get a more comprehensive view of the hijacking losses sustained by local truckers, a visit was made to Mr. Leslie B. Morash, President of the Transportation Security Council of Massachusetts, who provided us with statistics collected by his organization from newspaper clippings. According to this source, the total loss in 1976 in New England due to hijacking, theft of loaded vehicles, and armed robbery was \$3,516,806. There were 108 incidents during the year (72 private, 36 common carrier), 11 drivers were kidnapped, and armed robberies occurred at five terminals. In 1975, the losses totalled \$2,594,461 for 100 incidents and in 1974, they came to \$4,386,610 for 98 incidents. Since these figures are based solely on newspaper reports, they may be incomplete and the magnitude of the losses could be inaccurate. Unfortunately, more reliable data is not available. Insurance claim reports assembled by the ICC for class 1 and Class 2 carriers in 1973 showed the loss levels indicated in the following table:

	<u>United States</u>	<u>%</u>	<u>New England</u>	<u>%</u>
Shortages	\$60,263,000	88.12	\$1,559,000	72.95
Thefts/Pilferage	6,357,000	9.30	255,000	11.93
HiJack	<u>1,764,000</u>	<u>2.58</u>	<u>323,000</u>	<u>15.12</u>
	\$68,384,000	100%	\$2,137,000	100%

If shortages are assumed to be caused by employee theft, then the theft-related losses listed above constituted 58.8% of all the insurance claims paid to Class 1 and Class 2 carriers in 1973 in the United States, but these losses amounted to only .6% of their total sales. At the other extreme, the Aerospace Corporation claims that the average annual loss by hijack or theft of trucks engaged in urban pickup and delivery service is \$1950 a year. Another survey by the Senate Select Committee on Small Business in 1972 placed the total cost of cargo theft in the United States at \$1.5 billion a year, \$900 million of which occurred in the trucking industry, but 85% of this loss, typically, was internal theft by employees (Reference 57).\* In the opinion of personnel in the Major Crime Unit of the Massachusetts State Police, 60 to 75% of the truck hijackings may also involve employee collusion. If this is the case, a driver-actuated alarm system, by itself, cannot be relied upon for protection.

The lack of authoritative data on the extent of hijacking losses makes it difficult to evaluate the potential benefits of a protective device based on AVL techniques. If the Aerospace estimate of \$1950 in losses per pickup/delivery truck per year is correct, however, then clearly the investment of a comparable sum in protective equipment is worthy of careful consideration.

The ability to assign the nearest truck to a pickup and to supervise the drivers more effectively are additional benefits that would be of significant value also. Mr. Morash, who is also the President of the B.N. Corkum Transportation Company, stated that with proper monitoring

---

\*If this estimate is accepted, then the total nation-wide loss due to hijacking and overt theft was 15% of \$900M or \$135M annually. Conversely, if the New England losses, which averaged \$3,500,000 per year in 1976, 1975, and 1974 according to the Transportation Security Council of Massachusetts, are assumed to be 7.1% of the national total (as indicated in the ICC 1973 figures), then the total domestic loss due to hijacking and overt theft would only be \$49,176,000. With the data available, therefore, we conclude that the actual total loss in the 1972-73 era was somewhere between \$50 M and \$135 M per year.

the productivity of his drivers could probably be increased by at least 10%. If it takes \$35,000 per year to operate a pickup/delivery truck (driver, gas, oil, maintenance, amortization, etc.), then a 10% boost in productivity would be worth about \$3500 per vehicle per year. If a 10% gain in productivity could also be realized from optimizing pickup assignments, an additional benefit of \$3500 per vehicle per year would be achieved.

A different type of pickup and delivery is provided by the Central Delivery service of Boston. They have 40 radio dispatched vehicles which are employed for fast pickup and delivery on a 24-hour-a-day, 7 day-a-week basis. Deliveries are made anywhere in the state, although 90% of their business is inside Route 128, the circumferential highway around Metropolitan Boston. An IBM card is punched for each customer call and these are posted on a status board by the dispatcher under the name of the driver assigned to the call. By keeping the cards in proper sequence, the dispatcher has a rough idea of where each driver is and where he will be in the future. The dispatcher's task is not merely to assign the nearest vehicle to a pickup, but also to combine all the deliveries to a given area in one vehicle. Mr. Brooks, the operations manager of the service, believes that AVL techniques combined with computer aided dispatching would be very helpful. The value would be even greater to the parent company in Washington, D.C., which operates a fleet of 200-300 vehicles with nine telephone clerks and three dispatchers handling several thousand calls a day.

The United Parcel Service, on the other hand, operates its 200 vehicles in the Boston area entirely on a pre-scheduled basis. Each driver has a fixed area in which he makes deliveries in the morning and pickups in the afternoon. The vehicles are not radio equipped. Ninety stops would be a typically daily schedule for one truck. In this mode of operation, AVL would be of little value unless security or supervision of drivers were problems of consequence and this does not appear to be the case.

The Boston Post Office serves 26 cities and towns with a fleet of 1100 vehicles utilized for mail delivery, mailbox pickups, parcel post delivery, intra-city transfers, and supervision. Inter-city mail transfers are now carried out by contractors using tractor-trailer combinations. Almost all vehicle movements are based on fixed routes and predetermined schedules, so the value of knowing vehicle locations at all times is not great. The ability to supervise the drivers more closely is a possible worthwhile benefit according to Mr. John Moran, Manager of Vehicle Services for Boston. Security is not a problem!

Service firms\* employ a large number of trucks in every metropolitan area. We contacted a typical firm, the A.W. Ashton Company, which operates a fleet of 11 radio-dispatched trucks in its electrical contracting business, to check on the applicability of AVL techniques. The Ashton mobile units, for the most part, remain inside the Route 128 circumferential and whenever they transfer from one job to another, the central dispatcher is notified. A large number of calls for emergency service are received each day which must be assigned to units already in the field. On the average, however, each unit only handles about 4 jobs a day. With a fleet of this size (11 vehicles) and a small number of stops per vehicle (4), the task of keeping track of the location and status of each unit can be readily carried out by the central dispatcher. AVL or CAD systems do not appear to be cost effective for a business of this size, but sharing a metropolitan area AVL service with other users might provide a low-cost means of supervising the operations of numerous small fleets.

The utility companies all have large truck fleets employed in routine installation and emergency repair work. New England Telephone

---

\*Plumbing, heating, electrical contracting, telephone, power, gas, septic tank service, carpentry, refrigeration, air conditioning, uniform rental, linen supply, laundries, locksmiths, road service, TV repair, dry cleaning, copy services, vending machines, burglar alarm service, messenger service, armored car delivery, ticket delivery, film processing, newspaper distribution, auto parts distribution, diaper services, flower delivery, air freight pickup and delivery, etc.

operates a total of 8500 trucks, but the foreman in a given area, such as Cambridge or Boston, has only a small number of emergency vehicles under his direct control. Most telephone trucks, except in the rural parts of New England, are not even radio equipped. Under normal conditions, a vehicle crew starts out with a pre-determined sequence of jobs every day, and reports via phone to the local foreman after each job is completed before moving on to the next site. This control system appears to be adequate except in disaster situations (hurricanes, ice storms, floods, etc.) where emergency assignments must be made to vehicles already in the field and where a large number of outside trucks are often brought into the disaster area to assist the local crews. The inescapable conclusion, however, is that if New England Telephone has decided that two-way radio is not worthwhile, then it is unlikely to install AVL equipment in the near future. We were told by Sgt. Fickle of the Huntington Beach Police Department that the Los Angeles Telephone Company was interested in AVL to provide security for trucks that pick-up pay phone money. Apparently enough collectors have been robbed in that area to make the consideration of AVL monitoring worthwhile. As in the case of truck hijacking, however, employee collusion is probably a factor in a significant percentage of the "robberies."

The Boston Edison Company operates 400 to 500 trucks dispatched from eight locations scattered about the Metropolitan Boston area. Each supervisor is in direct radio contact with his trucks, but when outside trucks are brought into the area to assist the local crews, they are accompanied by radio-equipped Edison vehicles for relaying messages transmitted on the Edison channels. Supervision of crews is largely carried out via radio, although occasionally a supervisor will personally visit a job site. Mr. Paul Ardito, a manager of repair and maintenance crews for Boston Edison, was interested in the application of AVL techniques for the coordination of emergency services and for supervisory functions, but he was unwilling to make a judgement without having firm estimates on cost and performance.

### 3. LOCATION TECHNOLOGY

During the course of this study, the various operational or proposed methods of terrestrial radio determination (TRD), particularly automatic vehicle location (AVL) and monitoring (AVM), have been identified and studied to the extent of available information. Two operational AVM sites were visited (the St. Louis and Huntington Beach Police Departments), contacts were made with the manufacturers of these and other types of TRD equipment, and the extensive literature in this field was carefully reviewed. Also, important new comparative test results in the urban environment for three of the four basic TRD system types became available in June, 1977, as a result of UMTA/TSC-sponsored tests in Philadelphia.

Except for some in-house data obtained in tests of a Loran-C receiver conducted as a thesis project under the contract, the discussion is based on results obtained by others as published in the technical literature or in report form. In line with the contract directions of looking ahead toward possible future widespread use of TRD techniques, and in particular toward common, multi-user systems that might serve a variety of requirements, the emphasis has been on determining and setting forth the general characteristics of the various location techniques in such matters as accuracy, capacity (number of position determinations per unit time), coverage area, and cost. Some of these factors are intertwined with the communications question, as will be discussed in Section 4. The present discussion concerns only the basic location technology.

Section 3.1 below discusses general system issues of TRD technology including comments on factors that have affected system choices in systems to date, definitions of centralized and de-centralized systems and user requirements, brief review of the characteristics basic to TRD technology classes, and hybrid systems, i.e., use of more than one basic TRD technology in a single system. Section 3.2 discusses the results of recent (1977) test results for four AVM systems in Philadelphia (including three of the four basic TRD techniques), and Section 3.3 describes the results of some tests made by M.I.T. on a Loran-C receiver as part of the present project.

Section 3.4 represents some final observations on location technology.



### 3.1 TRD System Considerations

#### 1) System Choice

Choice of the best TRD system for a given application depends, of course, on what one is trying to do, how much one wants to pay for it, and existing TRD facilities (e.g., Loran-C coverage, proximity devices, etc.) that may already be available in the operational area of interest. Up to the present, most TRD applications have been in virgin territory in which there were no existing facilities to consider. Also, each TRD system has been primarily planned and installed by a single user. Thus, each application has installed a complete system, including the position determination component to meet his own needs and without particular reference to other possible needs in the same area.

The diversity of technologies is well illustrated in the literature (References 1,2,6,7,15), and an almost random selection from them is evident in the few existing or planned installations to date. For example, the Chicago Transit (Monitor-CTA), the Montclair Police, and the Huntington Beach Police installed signpost (proximity) systems (References 44,10,1), the St. Louis Police have a dead-reckoning system (References 9,25), and the Dallas Police are in process of installing a wideband pulse-multilateration system. Two signpost systems, one pulse multilateration system, and one Loran-C system are currently in contention for the Los Angeles bus transit installation, which includes requirements for some random-route capability (References 43 and 59), and Loran-C is under consideration for the New York State Police (Reference 4). Finally, a phase-locked AM-Broadcast AVL system is about to be tested with a truck fleet in Los Angeles as an anti-hijacking aid (Reference 26). This diversity is typical of a new technology (AVM) and, of course, has been influenced by the states of development, costs, and relative performances of the various approaches at the time that each procurement decision was made, as well as by the requirements set forth by the procuring agencies, which were quite diverse in nature, particularly in regard to AVM coverage and accuracy.

An interesting aspect of the history to date regarding Loran-C is that none of the present operational AVM systems are in areas of the U.S. that had Loran-C coverage at the time these systems were procured, thus it was not a viable option for those systems. With the expanded coverage now going in on the Gulf Coast (7/78), the West Coast (1/77), and the Great Lakes region (2/80), only the band of states roughly between Nevada and Nebraska will be without Loran-C coverage by 1980 (3 to 5 additional transmitters have been proposed to fill this gap, but have not yet been authorized). The expanded coverage and the recent improvements in Loran-C technology (better transmitter timing and low-cost receivers) make Loran-C a contender for many more locations, as evidenced by its present consideration for Los Angeles and New York State. However it must still compete on a performance basis in individual applications decisions. As will be described, it has not demonstrated itself to be the most accurate of the present technologies in the urban environment and may lose out on that count for particular requirements. On the other hand, its inherent coverage capabilities over broad reaches of the U.S. commend it for wide-area applications that are just beginning to be evolved, and hybridization with other TRD technologies and/or installation of local mini-chain Loran-C transmitters can help it to meet high-accuracy requirements in critical locations.

The issue of system choice will of course continue, but its nature will be continually changing as technologies improve, as TRD applications (and therefore installed facilities) increase, and most particularly, if actions taken at the national government level push TRD technology in a specific direction, as has happened in the standardization of Loran-C for marine navigation in the Coastal Confluence Zone.

## 2) Centralization vs. De-Centralization

From a technology viewpoint, TRD systems can broadly be divided into two classes: centralized systems (those in which a central location is involved in some way in determining the positions of participating mobile units), and de-centralized systems (those in which a mobile unit

can determine its own position without communicating with any other location). From a needs viewpoint, TRD systems can also be either centralized (a central location wants to know where each participating mobile unit is but the units do not need this position information), or de-centralized (only the mobile units are interested in their own positions, e.g., for navigation). These two viewpoints form a matrix with four intersections such that either centralized or de-centralized TRD technology can be used to fill centralized needs, assuming communication capability in either case. Similarly, although de-centralized needs would normally be met by de-centralized technology (i.e., one in which mobile units can determine their own locations independent of any central system), they can also be met by centralized TRD technology if one is willing to depend on a central-to-mobile communication link for position information at the mobile units. Thus in characterizing TRD systems as centralized or de-centralized, it is useful to distinguish between the means of position determination on the one hand, and the information flow on the other.

It is important to note that centralization may reduce costs and/or improve performance in a TRD system, even when the information needs are decentralized, and basically de-centralized technology is employed. For example, Loran-C may be operated in any of the four modes described, depending on how the signal processing to convert time differences to position information is distributed between the mobile units and the central location. Stand-alone capability in the mobile units obviously requires replication of position signal processing in each mobile unit. The AVM systems based on Loran-C that have been proposed restrict in-vehicle processing to establishment of time differences (TD's), which are then communicated to the central location for further processing to yield position information. Since central processing can include a larger data base on known local anomalies, differential corrections from a monitor receiver (also possible without central processing -- Ref. 28), inclusion of other data (e.g., proximity devices), and map matching with a road or waterway network, greater position accuracy is practical than with in-vehicle processing. Also, a centralized processor

can cost less than the sum of the individual processors when any substantial number of mobile units is involved. Thus even when centralized information needs do not exist or are only secondary in nature, there still may be great advantage in using centralized processing of Loran-C TD's and communicating the resulting position information back to the mobile units. As soon as centralization is applied, however, the issues of capacities and response time arise, as determined by communications and data processing.

### 3) Basic TRD Categories

TRD technology and specific systems have been extensively described and analyzed in recent literature (e.g. References 1,2,6,7,15), and there is therefore no need to redevelop such detailed information here. For purposes of the present discussions, it is useful however to review the four basic types of TRD systems (in terms of the way in which position information is determined), with some general comments on their modes of operation and relative capabilities in various system measures of interest.

#### a) Hyperbolic Navigation Systems (e.g., Loran-C and Omega)

This class of systems transmits synchronized signals continuously from multiple locations such that by measuring time or phase differences for two pairs of transmitting stations, a mobile unit can locate himself at the intersection of two hyperbolic lines of position (LOP's). Conversion of time or phase difference data to LOP's on the earth's surface is by use of tables, overlay maps, or direct computation. This may be done in the mobile unit, or, as previously discussed, measured time or phase difference data may be transmitted to a central location for position determination.

The basic hyperbolic TRD system has no capacity limit in terms of mobiles that may determine their own positions

from the transmitted signals. In centralized use, capacity is determined by mobile-base communications and centralized data processing. Note however that since there may be any number of bases, each working with its own group of mobile units on a separate communication channel, capacity in centralized use is also in principle unlimited, so long as there can be more than one "central".

By nature, hyperbolic systems operating at low radio frequencies (10-100 kHz) provide continuous coverage over very large areas, except in specific locations where the signals are shielded from reaching a mobile unit, e.g., in deep natural canyons, in high-rise urban areas, inside tunnels, etc. Baselines for the Eastern U.S. Loran-C chain, for example, are measured in hundreds of miles. Of all the system types, they seem to offer the most cost-effective way of providing basic TRD coverage over the whole U.S. or regions thereof, at least from the point of view of the number of fixed installations required. As will be evident in later discussions, hybridization with other techniques may be necessary to augment the basic coverage in difficult spots and/or to meet accuracy requirements exceeding the capabilities of the basic system, but the costs of such augmentation would be part of specific user systems. Unfortunately, the difficult spots also tend to have the highest traffic density.

b) Multilateration Location Systems

This class of systems also uses multiple fixed antenna sites, but operates cooperatively with one mobile unit at a time. The usual arrangement is for the mobile unit to transmit a tone (phase system or a pulse signal), which is received at multiple fixed sites (three, minimum). Each receiving site measures time of arrival (or phase) against a synchronized reference, and transmits this data to the master site for computation of the position of the mobile unit. The mobile transmissions are at definite times as determined by synchronizing signals from a master fixed-site transmitter. Mobiles

may be addressed singly for response, or in groups in a time-slotted arrangement.

Since a multilateration system can work with only one mobile unit at a time (in a time-multiplex manner) when measuring position information, its capacity is determined by the time per position measurement and the desired update rate for each mobile. Once the capacity limit of a system has been reached, additional capacity in the same geographical area requires installation of one or more additional systems operating on different frequencies. Some facilities, such as sites for antennas, could of course be shared for installation purposes, but not much else.

Multilateration systems operate at high frequencies and do not provide the area coverage of hyperbolic navigation systems. Tone-phase systems, which do not seem to be much in favor these days, are authorized to operate on 25-kHz land-mobile radio channels in the 25-, 50-, 150-, and 450-MHz bands, and pulse systems, which require much wider bandwidths (up to 8 MHz), currently are authorized to operate only in the 900-MHz region of the spectrum (Ref. 61). Propagation range for good performance is such that system baselines are limited to perhaps 20 miles maximum (in the 1977 Philadelphia tests of the pulse-trilateration technique described in Section 3.2, receivers were sited in a triangle 6.5 miles on a side). Thus a given multilateration system can probably cover an area about 30 miles in diameter at best.

#### c) Proximity Location Systems

This class of location systems depends on having a large number of dispersed wayside location devices such that when a mobile unit is within a certain distance of a wayside device (i.e., in proximity), it either obtains an identification number from the wayside device (a direct proximity system) or the

wayside device obtains the mobile unit number (an inverse proximity system). The transmission between the mobile unit and the wayside device may use radio, optical, or magnetic induction techniques, and may be one-way or two-way. In two-way proximity transmission, the responding unit may be either active or passive in nature.

Mobile unit position is determined by sending the mobile unit and wayside device identification numbers resulting from proximity transmission to a central location by radio (or by land line in inverse proximity systems). In one current proximity system (to be described in Section 3.2), the mobiles are able to determine three different radii from each wayside transmitter on the basis of signal strength, and the transmitters are adjusted so the third (lowest-level) zones from adjacent transmitters overlap. The additional information on the detection zones thus defined is also transmitted to the base in this system.

Capacity of a proximity system depends on the type of proximity device used and the organization of information flow. For example, continuously transmitting radio wayside devices (signposts) may be used by any number of mobile units (just like a hyperbolic system), and capacity is limited only by mobile-base communications and data processing. As in hyperbolic systems, multiple bases may operate independently, each with its own group of mobile units, and capacity is thus in principle unlimited. On the other hand, an inverse proximity system can have only one base and group of mobile units. Two-way, responsive proximity transmissions are subject to saturation and/or interference effects when more than one mobile unit is in the vicinity of a wayside device.

In comparison to hyperbolic and multilateration systems, which determine the exact vehicle location at all times (subject to

measurement error), proximity systems quantize position to the signpost spacing, with an uncertainty equal to the effective radius of the proximity detection, and may provide no direct coverage between the detection zones around each transmitter, which may be up to a mile apart. Thus it is common in proximity systems to incorporate some features of dead-reckoning systems (see below) to interpolate between signposts. However, the three-zone proximity system referred to above is usually laid out so that coverage is continuous, with quantization equal to one-fifth the transmitter spacing. If 300-foot accuracy is required on a uniform basis, transmitters must then be spaced no more than  $5 \times 300 = 1500$  feet apart.

Since the number of proximity devices needed for area coverage is proportional to the square of the coverage radius, and inversely proportional to the square of the spacing, it can be quite large for high accuracy requirements over substantial areas. For example, 1/4-mile spacing everywhere in the Greater Boston area (inside Route 128) would require roughly  $\frac{2}{3}(\pi \times 11^2) \div (1/4)^2 = 4,055$  devices (about 1/3 of the circle centered on downtown Boston is water). The number required for fixed-route applications (e.g., bus routes, or interstate highways) is a linear function of route length.

#### d) Dead-Reckoning Systems

This class of systems depends on each mobile unit having on-board devices to measure travel direction and distance such that its ground track from a starting point can be determined, and thus its present location. While in principle dead reckoning permits a mobile unit to determine its position independently, the instrumentation type and quality needed for really accurate, long-term dead reckoning (e.g., as in aircraft inertial navigation) is impractical for terrestrial position determination uses. Also, error accumulation is roughly proportional to distance traveled. Thus, a terrestrial dead-reckoning



system needs to be corrected at frequent intervals by some other means of position determination in order to maintain reasonable accuracy. This is most easily accomplished in a centralized system.

For example, the Boeing FLAIR dead-reckoning AVM system now operational in St. Louis measures vehicle wheel rotation and compass heading incrementally and transmits this information every 1.25 seconds to a central location where it is matched against a street map and automatically corrected (if necessary) each cycle to keep the calculated vehicle position on the street network. An error may, of course, be made if the correction process picks the wrong street after a turn, and thresholds are therefore set on the amount of position correction permissible before the vehicle position is declared in doubt. Such vehicles must then be reinitialized by going to one of a number of locations established for this purpose. At present this is a manual operation requiring cooperation of the vehicle operator but could be made automatic by installing proximity devices at the reinitialization locations.

The capacity of a dead-reckoning system employing central tracking is limited only by the communications and data processing functions. In the FLAIR system described above, for example, the present communications capacity is 200 vehicles per 25-kHz radio channel, and the data processing capacity per computer is 1000 vehicles. FLAIR would use five radio channels for a 1000-vehicle system in its present implementation (Reference 62). These of course are parameters of a particular system based on a philosophy of sending incremental motion information at a very high update rate (every 1.25 seconds for each vehicle). A different configuration with some on-board processing might change these numbers, but probably not very much. If messages were sent less often, they would have to contain more information.

The coverage of a dead-reckoning system can in principle be as large as desired, but there are some practical considerations. Because of the error accumulation problem in odometer data, some means of frequent along-track correction must be available, and this is usually based on the event of turning from one street to another. This works well in a high-density urban area for vehicles making frequent turns, but becomes more of a problem in areas of less street density where vehicles may travel for miles on a straight road without any turns (e.g., on a suburban freeway). Thus the tracking problem becomes more severe as the coverage of a pure dead-reckoning system is extended outward from the urban core. Hybridization with proximity techniques could, of course, aid in this regard. The data base required for map matching also grows with the area covered, which must ultimately place a practical bound on the coverage area of a single system. A dead-reckoning system does not differ from the other TRD techniques in this regard whenever exact travelway identification is required, but the other techniques can operate with less detailed information when such identification is not required.

#### 4) Hybrid Systems

In the preceding section describing the four basic position location technologies, some references have been made to hybrid combinations among them. This subject will be further expanded upon here.

As previously described, dead-reckoning inputs are usually added in proximity systems to interpolate between wayside transmitters. They may also be added in hyperbolic and multilateration systems for the purpose of track smoothing, i.e., to improve the estimate of a vehicle's position as a function of time. Both hyperbolic and multilateration systems are subject to propagation anomalies and measurement errors which tend to be random in nature as the mobile unit moves about. Thus additional information about the unit's actual movements can be helpful in reducing the effect of these errors.

Another problem with hyperbolic and multilateration systems is that there may be locations in the service area that are shielded such that received signal strengths fall below usable margins, or have high local man-made noise levels. A mobile unit's position cannot be measured accurately so long as it remains in a shielded or noisy location, or may not be measurable at all. Shielding has proved to be a problem in the high-rise areas of cities, and under overhead structures such as elevated roadways, and noise may come from power lines, electrical transit lines, etc. Proximity devices may be used as "gap fillers" in such locations, with or without added dead-reckoning inputs, or dead reckoning may be used alone (it is assumed here that even though location signals are shielded, mobile/base communication is still possible, which is usually the case).

A further accuracy improvement technique that is inherent in proximity and dead-reckoning systems, and that can also be applied in hyperbolic and multilateration systems, is map correlation. Unlike the air or sea situations in which a plane or ship may move freely, land vehicles are generally constrained to move on a street or road network or other defined pathways (e.g., alleys, parking lots, etc.). Thus, measured position data can be compared with possible paths, and off-path data corrected to the nearest path. Note that this does not help along-path errors, but these are not usually as critical, i.e., it is usually of more interest to know which path a vehicle is on than exactly where it is on that path. (An exception would be fixed-route bus AVM, where the path is known a priori and the critical parameter is position along the path). Along-path errors can be corrected in map correlation whenever a vehicle makes a turn into another path, so long as the system accuracy is such that it is clear which path has been turned into. This is the origin of the common criterion for maximum allowable system measurement error ( $2\sigma$ ) in urban AVM systems as less than half the short dimension of a typical city block.

In addition to direct map correlation, other techniques may be applied in data processing to reduce the effect of random errors in

position measurements. If a mobile unit is polled at regular, frequent intervals for position data, a moving-average track vector can be calculated using a suitable smoothing algorithm that takes into account the physically feasible changes in unit position between updates. This can be done on the basis of basic position measurement data alone (e.g., Loran-C time differences), or as previously discussed, can be augmented by data from dead-reckoning sensors on the mobile unit.

Finally, "stable" propagation anomalies of two types exist in long-range hyperbolic systems like Loran-C and Omega. One of these is due to slow changes in propagation velocities over the paths from the transmitting stations to the operating AVM area, which may be several hundred miles in length. The effect of this type of error can be removed by using a fixed monitor receiver and correcting all system measurements by the changes in its output, i.e., operating differentially (Reference 28). It is also possible to improve Loran-C in this regard (and in signal strength) by installing a local mini-transmitter to substitute for one of the standard Loran-C chain transmitters, or by installing a complete local mini-chain.

The other type of propagation anomaly is quite local in character, perhaps restricted to locations within a few feet of whatever is distorting the field pattern of the hyperbolic system signals (e.g., power lines, trolley tracks, etc.). Such local anomalies can be mapped and corrected for in the data reduction.

As an example of the extent to which hybridization is being carried in AVM systems to achieve accuracy goals in the urban environment, the system architecture proposed in 1975 by the Teledyne Systems Company for a Loran-C based system is of interest (Reference 29). Teledyne uses differential correction and map correlation as relatively standard techniques for Loran-C AVM. For difficult signal locations they have devised "augmentors", which are proximity signposts, each transmitting a unique identification code (the augmentor transmissions are on a channel in the HF radio band, 72-76 MHz, and each vehicle must have a special receiver). A vehicle receiving an augmentor transmission reports the identification code so long as it is in the proximity of

the augmentor, causing the central system to shift automatically from Loran-C to proximity processing. If necessary to achieve accuracy goals, Teledyne may also include vehicle sensors (odometer readings and a turn sensor) for path interpolation, and/or a low-power minichain Loran-C transmitter for the service area. Each of these options contributes its share towards error reduction, and, of course, to system cost. In Reference 29 (a 1975 study), Teledyne states that 300-foot accuracy everywhere in the city of Philadelphia would require all the options, but that the local minichain transmitter (a costly item) and the vehicle sensors could be dispensed with in a 1000-foot system. In the recently conducted Philadelphia tests for TSC/UMTA to be described in a later section, Teledyne used all of the above-listed options except a turn sensor. The test requirements included accuracy goals of 300 feet (95%) and 450 feet (99.5%).

The two present operational AVM systems (St. Louis and Huntington Beach) are not hybrid systems -- the former is a pure dead reckoning system (St. Louis) and the latter is a multi-level proximity system providing continuous coverage on the basis of five signal-level zones between each pair of proximity transmitters. As has been mentioned, it appears that one aspect of the operation of the St. Louis System, the manual re-initialization of "lost" vehicles, could be improved by hybridization, i.e., use of proximity devices at reinitialization points (Ref. 62; see also the St. Louis visit report in Section 8 of the Appendix). The accuracy requirements of the Huntington Beach Police Department are 800-1000 feet over most of the city, 500 feet in special areas (Reference 1, Vol. 1, p. 2-154). At this level of location accuracy requirement, additional inputs would be of little use. In fact, as described in Section 3.2 following, the same proximity-only system deployed in Philadelphia achieved 242-foot accuracy ( $2\sigma$ ) in the random-route portion of the recent UMTA/TSC tests. Of course, the signposts were more closely spaced in Philadelphia because of the  $2\sigma$  accuracy requirement of 300 feet.

### 3.2 The 1977 Philadelphia Tests

#### 1) Introduction

Under Phase I of the UMTA/TSC program to install an AVM system in Los Angeles for bus transit use, including some random-route experiments (Reference 43), four contractors tested different AVM systems in Philadelphia in the first half of 1977 (Reference 59). The four systems tested were a Loran-C system (Teledyne Systems Co.), a wideband pulse-trilateration system (Hazeltine Corp.), and two signpost proximity systems (Fairchild Space and Electronics Company, and Hoffman Information Identification, Inc.).

The results of the tests and comparison to the specifications for Los Angeles are well described in Reference 59, however some observations on the results are developed here.

Because of the temporary nature of the test site, three of the contractors did not install communications or data processing systems, but employed data recording in the mobile vehicle for later processing by pre-certified programs. Thus, the communications functions of these systems (Teledyne, Hoffman, and Fairchild) were not tested. The Hazeltine system, on the other hand, required temporary installation of the central synchronization transmitter and fixed receiver sites, and since communications time slots are part of the system location transmissions, the two-way communications functions of the Hazeltine system were, in essence, tested along with the location functions. For the Hazeltine system, the time-of-arrival data were recorded at Central, again for later off-line processing.

None of the tests seems to have gone off letter-perfect on all counts, in some cases due to system or test equipment equipment problems of one sort or another, and in other cases due to lack of provision in the data reduction software for certain operational conditions. Thus the TSC report lists both the raw test results (in some cases both before and after a hardware change), and "edited data results", in which known faulty data and/or poor data due to correctable system problems have

been eliminated. The report presents no conclusions about or among the various systems -- it simply describes the systems, the test procedures, and the results.

## 2) The Los Angeles Accuracy Requirements

The basic requirements for the Los Angeles system are position location accuracies of 300 feet (95%) and 450 feet (99.5%) defined at both a subsystem and a systems level for both fixed-route and random route, and time-point accuracies of 15 seconds (95%) and 60 seconds (99.5%). In both cases, the 99.5% ( $3\sigma$ ) limit is imposed to limit the frequency of very large errors. In addition, a coverage specification limits average error on any 0.1-mile segment of any route to 450 feet to ensure that there are no pockets of poor (or no) performance. The TSC report tabulates all results, both raw and edited, against specifications, which was the purpose of the tests. The present discussion is not as concerned with these particular comparisons as with the configurations, and relative performance of the three basic system types in this most recent test of various techniques under identical conditions in a difficult environment.

## 3) The Tested Systems

The systems tested in Philadelphia were all hybrid in that each used combinations of basic location techniques in order to meet all of the various system specifications. It is interesting that the 15-second (95%) time-point specification raised special problems compared to a pure location specification. For example, every system found it necessary to locate a proximity device at each time point in order to meet the time-point accuracy requirement of the fixed-route tests.

Every system except the Hazeltine trilateration system used odometer data for interpolation and/or path smoothing, and one (Fairchild) added steering angle sensors and two-dimensional dead reckoning (with an on-board microprocessor) in the random-route tests because of the extremely small detection area of its "sharp" proximity devices. It thus might be

more fairly termed a dead-reckoning system, with precision (6-20 feet along-track) updates whenever a vehicle passes a proximity device. Hoffman, on the other hand, operated entirely with its complete-coverage, five-zone proximity system in random-route, but used odometer data for interpolation between time points in the fixed-route tests. This was because the proximity devices at the time points were too far apart (about one mile) to provide proximity zones sizes meeting the location accuracy requirements. Additional proximity devices could of course be used, as they were in Hoffman's random-route tests, but economics apparently favor odometer interpolation for fixed-route operation.

The Hazeltine system relied entirely on pulse trilateration for location in both random-route and fixed-route, and used "sharp" signposts only to meet the time-point requirement for fixed-route operation. It is apparent from the test results, however, that their signposts were not as "sharp" as Fairchild's. Fairchild's unedited results were 1 sec. (95%) and 2 sec. (99.5%), whereas Hazeltine's results (edited) were 15 sec. (95%) and 30 sec. (99.5%).

The Teledyne Loran-C system used proximity signposts (called Augmentors) for two purposes: to meet time-point requirements (as previously mentioned), and to fill in locations where the Loran-C signals were too weak for location operation, primarily in the high-rise areas. Odometer data was also employed for path interpolation and smoothing, and in the case of the fixed-route tests, to improve the accuracy of the time-point detection. This was done by adjusting all augmentors for a fixed initial detection range (54 feet) and generating a time-point signal when the test vehicle had moved 54 feet from initial detection. A temporary low-power mini-chain slave was also installed 40 miles west of Philadelphia to provide a stronger signal than the Dana, Indiana slave, which is about 8 dB weaker in the Philadelphia area than the North Carolina and Nantucket stations (Ref. 28), and not representative of Los Angeles conditions. Finally, 395 points in the working area were calibrated to permit distortions and anomalies in the Loran-C grid to be removed in data processing.



It is known that the Teledyne and Hazeltine data processing at the system level includes map-matching to improve accuracy; this is, of course, inherent in proximity systems.

As stated at the beginning of this Section the choice of location technique, or combination of techniques, depends on what one is trying to do. In this regard, it is noted that all four systems were deployed in different ways for the random-route and fixed-route tests, in two cases changing their basic position location technique, and in another adding an additional sensor type for fixed-route. As previously discussed, the emphasis on time points in the fixed-route specification was apparently a major factor in these changes. To indicate the severity of the 15-second time-point requirement in terms of location accuracy, a bus moving 5 miles per hour (7.3 feet per second) moves only 110 feet in 15 seconds, and the positional accuracy required is tighter the slower the bus moves.

As a comment on configurations, then, the Philadelphia tests illustrate the difficulty of devising common multi-user systems (including location technique, communications technique, and central processing) to meet a spectrum of user requirements. That is not to say that a common, multi-user location technology cannot be employed, but that different users may have to use it in different ways on a systems basis.

#### 4) Position Location Performance

For fixed-route tests at the subsystem level, the two proximity systems achieved 95% accuracies of 54 feet (edited) and 107 feet, respectively, and 99.5% accuracies of 70 feet (edited) and 156 feet. These numbers increased to 230 and 440 feet, and 242 and 461 feet in random-route tests. As noted in the preceding section, both proximity systems used different interpolation techniques in fixed-route than they did in random route, taking advantage of the known route.

The comparable figures for the pulse-trilateration system are (all edited figures): 270-440 feet (95%) and 490-940 feet (99.5%), for both random-route and fixed-route. The system operated the same way in

both tests. At the system level (for fixed-route only), these edited figures reduced to 191-325 feet (95%) and 490-655 feet (99.5%), taking account of data processing possibilities for a known route.

The fourth system (Loran-C) had comparable subsystem figures (all edited) of 303 feet (95%) and 1457 feet (99.5%) for fixed-route, and 358 feet and 1222 feet for random-route. The prevalence of a few percent of very large errors due to anomalous grid distortions is evident in the 99.5% figures, but the fact that they can be substantially eliminated in data processing is indicated by the system-level figures (all edited) of 291 feet (95%) and 383 feet (99.5%) for fixed route, and 325-472 feet (95%) and 375-819 feet (99.5%) for random-route.

The above figures are presented side-by-side in Table 3. It may be noted that although all four systems demonstrated the capability for 300-foot accuracy at the 95% level (the proximity systems more easily), the pulse-trilateration and Loran-C systems had trouble meeting 450 feet at the 99.5% level, indicating that the problem of occasional large-errors due to propagation anomalies, loss of signal, etc., in these location technologies has not been entirely solved, at least for the systems as deployed and tested in Philadelphia. The importance of this in any particular location system has, of course, to be balanced against other factors.

### 3.3 Loran-C Experiments by M.I.T.

An opportunity to obtain some hands-on experience with Loran-C arose during the contract when an undergraduate student (Constantine Photopoulos) became interested in conducting urban measurements as a thesis project, and Internav, Inc. indicated its willingness to loan a Loran-C receiver to M.I.T. for such a test. The thesis research (Ref. 49) was conducted during April-May, 1977, and included static measurements at the Electronic Systems Laboratory with a roof-mounted antenna, and mobile tests at various Boston-area locations with the receiver mounted in a laboratory station wagon. The same 8-foot whip antenna was used in all measurements.

TABLE 3 - Comparison of Position Location Accuracy Results  
for 1977 Philadelphia Tests for Four Systems

	Fairchild (Sharp Proximity)	Hoffman (Broad-area Proximity)	Hazeltine (Pulse Trilateration)	Teledyne (Loran-C)
<u>Subsystem Level</u>				
Fixed-Route 95%	54*	107	270-440*	303*
Fixed-Route 99.5%	70*	156	490-940*	1457*
Random-Route 95%	230*	242	270-440*	358*
Random-Route 99.5%	440	461	490-940*	1222*
<u>System Level</u>				
Fixed-Route 95%	81*	105	191-325*	291*
Fixed-Route 99.5%	125*	188	490-665*	383*
Random-Route 95%	220*	282	270-460*	325-472*
Random-Route 99.5%	430*	367*	693-940*	375-819*

Notes: Figures compiled from separate tables in Reference 59 (\*indicates edited data as described in reference). All figures are in feet.

The receiver used in the tests was an Internav Model 204, a fully automatic receiver designed primarily for marine use. Following panel-switch selection of the chain (in our case, the East Coast SS-7 chain) and the codes of the two desired slave stations, the receiver automatically locates and locks onto the proper cycles of the transmissions from the master (Carolina Beach, North Carolina) and the two slaves, and displays the S1 and S2 time differences (TD's) as digital readouts, with an indication resolution of 0.01 microseconds. The displays are updated at two-second intervals, with the S2 update offset by one second from the S1 update. This is because the receiver has only one timing circuit that is switched alternately between S1 and S2 for one second each. The slaves used in all the mobile testing were the ones at Nantucket, Mass. (Y) and Cape Race, Newfoundland (X). The Dana, Indiana slave (Z) was used in some of the laboratory testing.

Initial observation of the receiver operating in the laboratory indicated a change in each displayed TD on almost every update, with maximum excursion between the highest and lowest readings being about 0.30 microseconds. All subsequent measurements were therefore made by manually recording sequential two-second updates for 1-2 minutes and calculating means and standard deviations. These time factors were then converted to feet by using scale factors estimated from a 1:25000-scale Loran-C chart of the Boston area: about 848 feet per usec for the Nantucket Lines of Position (LOP's) and about 512 feet per usec for the Cape Race LOP's.

The accuracy of a position fix determined from two TD's depends on the gradients and crossing angles of the LOP's in the area. In the Boston area, the Cape Race and Nantucket LOP's cross at 40°, and the two-dimensional error distribution is elliptical, with a major dimension  $(E_{T1} G_1 + E_{T2} G_2) \cos 40/2$ , where  $E_{T1}$  and  $E_{T2}$  are the time errors, and  $G_1$  and  $G_2$  are the gradients (feet/microsecond). Thus the peak-to-peak  $TD_1$  and  $TD_2$  excursions of 0.3 microseconds discussed above correspond to 383 feet worst-case peak-to-peak fix error. This effect is called Geometric Dilution of Precision (GDOP), and charts with GDOP

contours are available for Loran-C chains as a ready means of determining fix accuracies. The remainder of the present discussion treats the two TD's separately for convenience, but the GDOP effect on location accuracy should be kept in mind.

Laboratory measurements with the receiver operating on 115-V line power were made on seven different days, the last four times as a check just prior to putting the receiver in the vehicle for a mobile run. The means and standard deviations for this series of measurements with a fixed antenna location (on top of a five-story building) are shown in Table 4. It will be noted that the standard deviations are fairly consistent from day-to-day, ranging from 25-45 feet for Cape Race and from 33-71 feet for Nantucket. However, it will also be noted that the means change from day-to-day, indicating either shifts in chain or receiver timing, or changes in propagation velocities. For Cape Race, the mean stays in a range of only 30.8 feet over the ten days (21.5 feet if the 5/6 reading is omitted), but for Nantucket, there is a shift of 107 feet between the first and second days (5/6 and 5/9), with a range of 60.4 feet for all subsequent readings. These day-to-day shifts in mean TD's indicate the desirability of using differential techniques in Loran-C AVM systems, i.e., correcting mobile unit TD's by amounts equal to the shifts in mean readings of a fixed monitor receiver tracking the same stations (Reference 28).

Curiosity was also aroused about the statistical nature of the short-term variations in TD readings because of what appeared to the eye to be a rather cyclic behaviour. A plot was therefore made of the 5/6 readings, and is shown in Figure 25. It is apparent that although the variations have some random content, a cyclic component with a period of about eight seconds (four sampling periods) is very prominent, particularly for the Nantucket TD's. These data were discussed with Internav, Inc. and Megapulse personnel to see if the cyclic behavior might possibly be attributable to the time constants used in the tracking loops of the receiver; however, this explanation was doubted. One suggestion was that the cyclic behavior might have been the result of a beat with some

TABLE 4 Changes in Loran-C Readings at M.I.T. over Ten Days

<u>Cape Race Readings</u>			
<u>Date</u>	<u>Mean TD (usec)</u>	<u>Standard Deviation (feet)</u>	<u>Mean relative to 5/6 mean (feet)</u>
5/6	37740.7026	33.4	
5/9	37740.6844	28.	- 9.3
5/11	37740.6480	29.6	-28.
5/12	37740.6468	40.6	-28.6
5/13	37740.6465	44.8	-28.7
5/14 (AM)	37740.6662	32.8	-18.7
5/14 (PM)	37740.6683	37.	-17.5
5/15 (AM)	37740.6425	25.2	-30.8
5/15 (PM)	37740.6453	35.3	-24.7
<u>Nantucket Readings</u>			
5/6	49391.9016	62.	
5/9	49392.0275	71.4	+106.6
5/11	49392.0007	66.2	+ 83.2
5/12	49391.9752	50.8	+ 53.9
5/13	49391.9732	56.6	+ 62.2
5/14 (AM)	49391.9875	46.7	+ 72.7
5/14 (PM)	49391.9904	39.7	+ 75.2
5/15 (AM)	49391.9582	39.7	+ 48.
5/15 (PM)	49391.9563	33.4	+ 46.3

interfering signal, and indeed, oscilloscope observation of the receiver output during the M.I.T. measurements indicated that very strong pulse signals were sweeping through the Loran-C pulses most of the time. It has since been learned that these signals originated from experimental operation of the new Caribou, Maine station in May

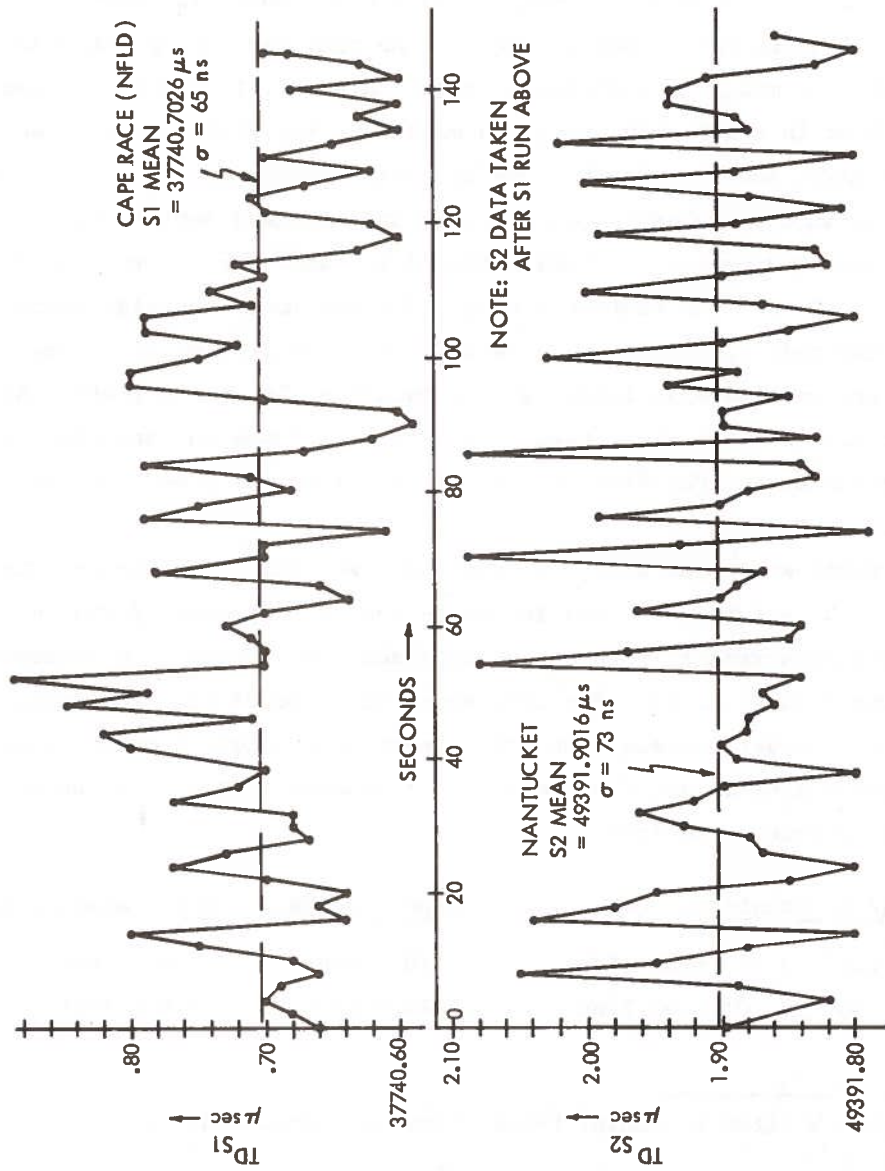

Figure 25. Loran-C Readings Taken May 6, 1977 at Fixed Location (MIT/ESL)

and June at a rate different than that of the East Coast chain, but that cross-rate signals should not cause such TD behavior.\*

If the data of Figure 25 are typical of Loran-C measurements, post-smoothing of the TD readouts would certainly seem to be in order. For example, a moving 5-point average (10 seconds smoothing) of the Nantucket data of Figure 25 reduces the peak-to-peak excursions from 300 nanoseconds to 80 nanoseconds (58 feet), and the standard deviation from 73.1 nanoseconds (62 feet) to 23.5 nanoseconds (20 feet).

Following the laboratory tests, the receiver was operated in the vehicle for mobile measurements on two days, May 14 and 15, at twelve locations in the Boston area, and each site was visited four times, in the morning and the afternoon of each day (Reference 49). At three low-rise locations in Cambridge and Brighton, standard deviations for Cape Race were comparable to those measured in laboratory -- ranging from 33 to 50 feet. The Nantucket standard deviations were also pretty much the same at two of the locations (ranging from 47 to 75 feet), but were considerably larger at one location (118 to 150 feet). At two medium-to high-rise areas in Boston (St. James and Berkeley Sts., and Boylston and Fairfield Sts.), the receiver would not lock on to the Loran-C signals.

Tests were made under an overhead power line (Allston and Carol Sts.), 50 feet from it, and 100 feet from it. Standard deviations for all measurements were again comparable to laboratory measurements, ranging from 40-62 feet for Cape Race and 61 to 84 feet for Nantucket, however, large, anomalous shifts in mean were noted in moving under the power line on all four occasions. Changes in mean for one set of readings were as follows:

<u>Change in Location</u>	<u>Δ Cape Race Mean</u>	<u>Δ Nantucket Mean</u>
from 100' to 50' from line	10.5 feet	46.1 feet
from 50' to 0' from line	248.9 feet	359.8 feet

---

\* Captain William B. Mohin, USCGS (Personal communication).



This anomalous behavior near fixed structures can, of course, be mapped and removed in data processing. Similar results were obtained in performing the same experiment near and under a rapid transit elevated structure (Nashua and Causeway Sts.). In moving from a point 100-feet from the elevated structure to a point 50-feet away, the Cape Race mean for all readings changed by 13 feet and the Nantucket mean by 23 feet. The receiver lost lock directly under the elevated line and no measurements were possible at that location.

Subsequent to these initial urban measurements, it was discovered that the battery-to-ac converter used to supply power to the Loran-C receiver produced an unacceptable ac output when the battery was not fully charged. A second series of tests were carried out in Boston, therefore, with the converter operating off the vehicle's regular battery-alternator supply. The results were much improved. Track was maintained on a loop through the downtown high rise area. The route included a 2-block section under the Causeway Street elevated and a passage under the Fitzgerald expressway. Remaining under the elevated structure for several minutes, however, later caused the set to lose track. Acquisition of a valid track on the Cape Race and Nantucket signals was accomplished at six different downtown locations, including the St. James-Berkeley and Boylston-Fairfield sites at which measurements could not be made in the initial test series. A Loran-C chart for Boston Harbor, produced by Internav from a theoretical evaluation of time differences, gave the following time coordinates for a specific check point on Nashua Street:

Cape Race	37726.2	$\mu$ seconds
Nantucket	49382.8	$\mu$ seconds

Actual measurements were made at this site on four separate occasions with two different 204 receivers, the average Cape Race Reading being 37725.81  $\mu$  sec's and the average Nantucket reading being 49381.99  $\mu$  sec's. Thus, relative to the chart, which is not an accurate absolute reference, the Cape Race deviation was .39  $\mu$  sec (200') and the Nantucket deviation was .81  $\mu$  sec (658'). A much more meaningful performance measure is

the repeatability of the time difference at a given location. At the Nashua Street site, the Cape Race averages had a maximum spread of  $\pm .13 \mu \text{ sec. } (\pm 67')$  and the Nantucket averages had a maximum spread of  $\pm .06 \mu \text{ sec. } (\pm 51')$ . The second set of Loran-C tests is more fully described in Reference 76.

### 3.4 General Observations on Location Technology

The preceding sections of this chapter have reviewed the characteristics of presently available TRD technology and systems, the results of the most recent comparative tests of AVM systems in Philadelphia, and the results of a small-scale Loran-C experiment, made in Boston as part of this study. Some general observations to conclude this review of TRD technology may be made as follows.

#### 1) Accuracy

The field of land vehicle position determination (AVM or AVL) has come a long way since active interest and work commenced about a decade ago. Any of the basic TRD technologies is now capable of providing a level of location accuracy that appears to be adequate for the AVM and AVL applications discussed in Section 2 under most conditions. Unusually severe accuracy requirements, where they exist, or difficult operating environments can in most cases be handled by hybridization among techniques. The two truly radio-determination techniques (Loran-C and multilateration) may in particular need augmentation with proximity and/or dead-reckoning techniques in areas subject to propagation problems such as field distortions, multipath cancellation, and shadowing.

#### 2) Coverage

The basic TRD technologies differ widely in respect to coverage characteristics. Any of them can apparently provide random-route coverage of a city-size area (say 10 miles in diameter) for land-vehicles, at reasonable cost, and coverage of major cities would account for a large fraction of the land-vehicle applications discussed in Section 2 and of the potential users in those applications. However, only two of the basic technologies (hyperbolic and multilateration) would also be able to serve aircraft and ship location or navigation requirements in those same areas.

Outside such areas with a high and medium density of potential land-vehicle users (e.g., in low-density suburban areas and on the open road), the cost of providing coverage by proximity, dead-reckoning, or multilateration techniques would appear to be high for the benefits obtained, and only a long-range system such as Loran-C seems cost effective. All of the land-vehicle applications discussed in Section 2 could benefit by AVM or AVL on a regional or country-wide basis, particularly:

Police, Fire, and Medical Services  
Truck Security  
Disaster Relief and Civil Defense

A long-range radio-location system is also required for air navigation and inland waterway applications, and of the present hyperbolic technologies meeting this requirement, only Loran-C has a usable combination of accuracy and coverage. These non-TRD applications were not studied.

### 3) Capacity

The basic TRD techniques also differ in characteristics affecting the number of vehicles that may use the service. In almost all land vehicle applications, the vehicles do not need information on their own positions: it is a central dispatcher or controller that wants to know. Thus, for land vehicles, centralized TRD systems are assumed and the question is how many vehicles can participate in a given TRD system. Depending upon the basic TRD system and the application, the limit may be a certain number of vehicles maximum, or an update rate of so many different vehicles per unit time. As has been explained earlier in the discussion of the basic technologies, dead-reckoning and proximity systems depend on centralized data processing for operation, and their capacities are limited only by the communications and data processing functions. However, they are limited in different ways. For the tracking that is an inherent part of the system operation, dead-reckoning systems must update each vehicle at intervals quite short compared to the intervals at which position information is needed in most applications. Thus the product of the update interval and the rate at which vehicle can be polled for position data determines a maximum number of vehicles per

channel or per system. In the Boeing FLAIR system, for example, the update interval is 1.25 seconds, and data for 200 vehicles can be read in this interval, per radio channel.

Proximity systems, on the other hand, do not have to track as part of the location operation, and the number of vehicles that may participate per system is determined only by the update requirements of the application, and the polling time per vehicle. If 50 vehicles could be polled per second on a radio channel (not an unreasonable figure, as will be discussed in Section 4 ), 6,000 vehicles could be updated every two minutes, 12,000 every four minutes, etc. These numbers can be expanded by use of additional radio channels.

In the only currently operating proximity system, Huntington Beach, California, the maximum polling rate is much slower (4.65 vehicles per second), largely limited by the channel turnaround delays in the Orange County selective-call radio network. Since the system shares the voice dispatch channel, vehicles are not "tracked" and are polled for position data only when there is a dispatch to be made. The maximum 50-odd patrol cars in the fleet can be polled in about 10 seconds, so this is a feasible mode of operation for a small fleet. With continuous polling, the system could update 560 vehicles per minute.

The capacities of dead-reckoning and proximity systems can be expanded indefinitely by paralleling communications channels, and data processors. Costs would increase linearly with fleet size in dead-reckoning systems, but in proximity systems the per-vehicle share of the fixed costs of the proximity transmitter installation would reduce with fleet size.

In multilateration systems, position determination takes a fixed time interval per vehicle, and each set of fixed receivers has a vehicular capacity set by application requirements for update rate(s). Once this capacity limit has been reached in a given system, a second set of receivers must be installed on another frequency. Although the synchronizing transmitter and the receiver sites might be shared, the costs of each additional parallel system would be almost as great as the first one.

The capacity of a single system is, however, substantial. The Hazeltine system slated for Dallas measures 500 vehicle positions per second, which would permit the updating of 60,000 vehicles in two minutes. Bandwidth required is 8 MHz, equivalent to 320 normal 25-kHz land-mobile communications channels.

Hyperbolic systems, of which Loran-C seems the only logical contender for the applications discussed in Section 2, have capacities in centralized operations that are limited only by communications and data processing. As in dead-reckoning and proximity systems, these functions can be paralleled, either in a single system or in separate systems. Furthermore, any number of mobile vehicles -- land-based, water-borne, or in the air -- may simultaneously operate on a de-centralized basis, i.e., independent of central data processing. In centralized use, and for a common communication technology, the capacity per radio channel will be less than that of a proximity system because of the longer message lengths required to transmit time-difference data compared to sign-post codes. In small-coverage systems, the time difference data can be truncated to only those bits that can change within the coverage area, but the number of bits required for two  $T_D$ 's will still be larger than a signpost numerical code. For example, in a 10-mile square area,  $T_D$ 's will vary by about 50 microseconds. If they are measured to 0.01 microseconds (the common resolution level), then each  $T_D$  has 5,000 possible values in the coverage area, and will require a minimum of 13 bits in reporting. In low-accuracy applications, it is also possible, of course, to truncate low-order bits. Dropping the three lowest-order bits in the above example would correspond to approximately 100-foot resolution in reporting.

The accuracy limits achievable with hyperbolic systems can be gauged by the results of measurements made with the short-baseline Loran-C chain installed by the Coast Guard near Sault Ste. Marie. The chain, consisting of four 100 watt Megapulse transmitters spaced about 30 miles apart, exhibited time difference errors of 15 nanoseconds or less, permitting fix accuracies on the St. Mary's River of  $\pm 25$  feet. Loran-C time differences measured on board a test vessel were used to plot its trajectory as it visited sequences of accurately tethered buoys. A typical trajectory, with the known buoy placements superimposed, is shown in Figure 26. (Reference 55).

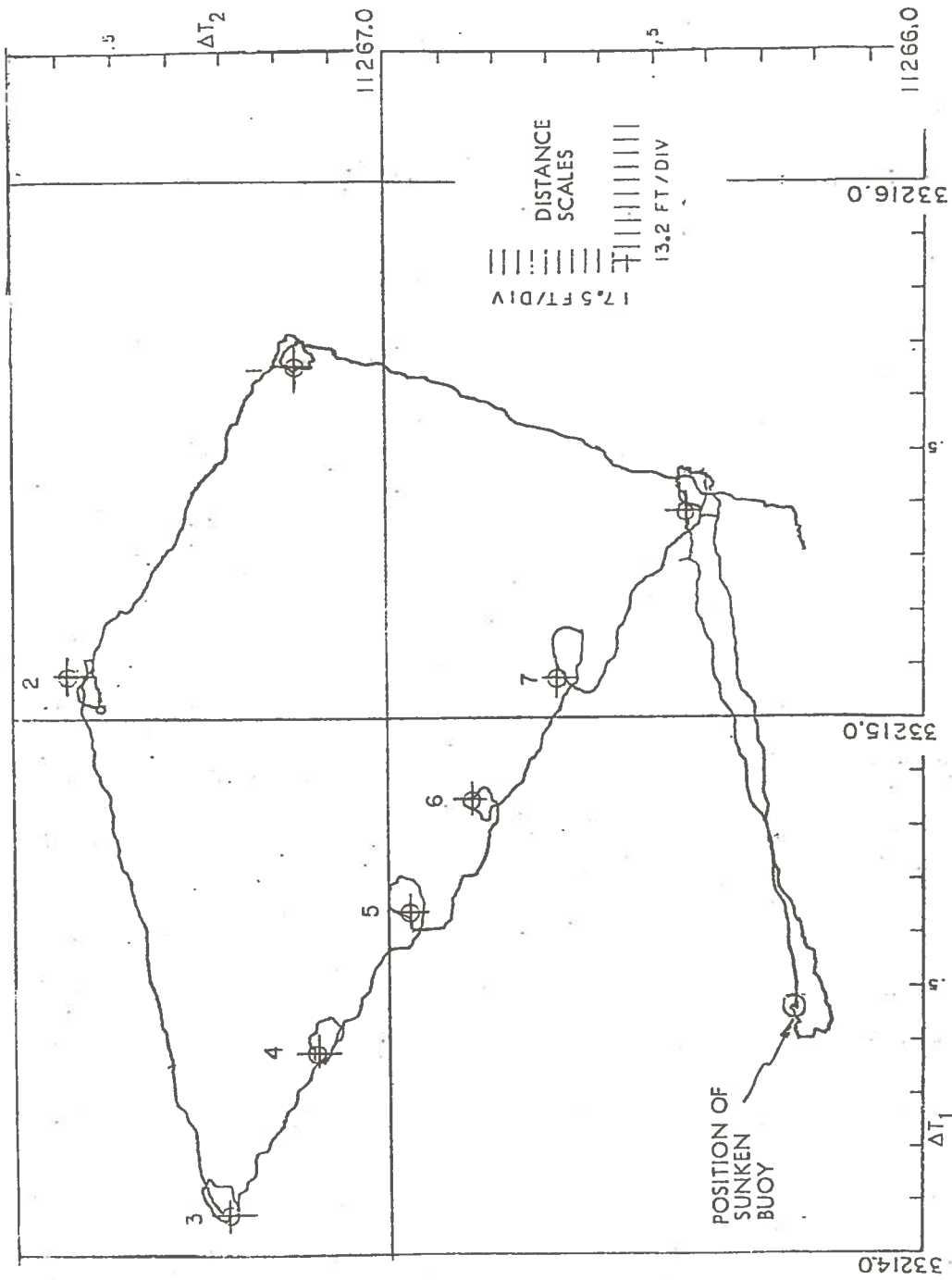

Figure 26. Plot of Vessel Trajectory Around Known Buoy Locations (Based on Loran-C TD's), St. Mary's River Tests 1977

## 4. COMMUNICATION TECHNOLOGY

### 4.1 Introduction

As discussed in the preceding section on Location Technology, TRD systems can be either centralized or decentralized. Centralization implies some sort of communication between each mobile unit and a central location, and that is the topic of this section. Information on the communications capabilities of current and proposed TRD systems has been accumulated and reviewed, and since digital communication on mobile-radio links is evolving rapidly in many non-TRD applications, available data on these other mobile digital communications systems has also been included.

The discussion is subdivided into four sections. Section 4.2 discusses regulatory issues, the techniques and problems of present land-mobile digital communications and the performance limits of TRD communication links. Section 4.3 reviews some of the basic communication disciplines involved when a centralized base communicates with a large number of mobiles. Several scenarios illustrating the different TRD communication capacities and parameter inter-relationships are discussed. Tentative comments are also made on wide-area and/or multi-user situations. Section 4.4 is a representative survey of various existing and proposed TRD communications systems. The parameters and operation of each system are described in detail and numerical indices are developed and compared in chart form. Section 4.5 discusses possibilities for improving the spectral utilization of digital transmission through definition of new digital-only channel specifications, and suggests a Federal policy initiative toward achieving such improvement.

### 4.2 Mobile Digital Technology

#### 1) Regulatory Issues

Mobile digital transmission in the Public Safety, Land Transportation, and Industrial Radio Services has until recently been authorized by the Federal Communications Commission only as a subsidiary use of voice-radio channels and equipment, with a two-second digital burst length limitation, and a requirement for voice station identification (Reference 61).

As AVM and mobile digital terminal systems have come into use, primarily in law-enforcement applications, two channel pairs in the Public Safety Service have been designated for all-digital use, but no all-digital channels have yet been designated in the other services.

A further FCC requirement on digital transmission is that the baseband modulating signals (i.e., the digital bit stream) must be passed through the same 3-kHz low-pass filter that it specifies for voice inputs to all land-mobile transmitters. This latter requirement is currently under review, as will be discussed in Section 4.5, but is a fact of life in all current land-mobile digital communications. One possible exception is in the Bell System cellular radiotelephone system currently being installed in Chicago, but that is a special authorization under a different part of the FCC Rules and Regulations. The gist of these regulatory issues is that the only radio channels available to the organizations that would be involved in most of the applications discussed in Section 2 are 3-kHz "voice" channels, generally on 25-kHz center-to-center spacing.

## 2) Equipment In Being

Another fact of life is that all of the presently owned land-mobile radio equipment, and all of the equipments available for purchase, are designed to the above F.C.C. standards. Thus, there has been an economic, as well as a regulatory incentive on the part of TRD system designers to offer digital data links as add-ons to standard voice radios. Various approaches have been taken as to the best way to do this, as will be further explained. The situation is much the same as in digital transmission over the telephone network -- a channel that was optimized in bandwidth for another purpose (voice transmission) is now to be used for digital transmission. Over the past 20 years, designers of telephone modems, as add-ons to the telephone network, have succeeded in overcoming the 3-kHz bandwidth limitation of the the telephone network by clever modulation, coding, and channel equalization techniques (not all of which can be applied in the radio environment), and 9600-bps telephone transmission is now routine. At the same time, however, the telephone network itself is changing gradually to digital transmission for all



services, largely removing the bandwidth limitations that modem designers faced. The possibilities for new types of "digital" channels in the land-mobile radio services to get around the voice-channel limitation is discussed in Section 4.5. The remainder of this discussion and that in Sections 4.3 and 4.4 is based on the present voice-channel transmission standards.

### 3) The Land-Mobile Channel

A digital communication link must be able to transmit and receive messages as fast and reliably as possible. One way to specify the reliability of a communication system is to say that for some percentage of the time; the message will be interpreted properly over some percentage of the area covered. The object is to make both percentages high enough to obtain efficient use of the frequency spectrum available, and at the same time, serve as many mobile units as possible. One of the most striking differences between digital communications and voice communications is the effect of errors. Because of the redundancy in voice, short fades or bursts of noise will not prevent a voice message from being understood. However, when machines automatically process digital data, even one error can cause the total message to be lost depending on how the system is designed. To understand why errors occur so often in mobile digital communications, some of the more dominant features of the mobile channel must be considered.

One of the most important problems in mobile reception in urban areas is that of deep signal fades as a function of mobile position, due to multipath reception. It has been well documented that signal strength in urban areas follows a Rayleigh probability distribution, which says that fades of 20 dB or more below median may be expected 0.5 percent of the time, or at 0.5 percent of locations. As a vehicle moves along a street, the reflected signals received tend to reinforce or cancel alternatively at intervals of about one-half the transmitted wavelength, so that signal amplitude received in a moving vehicle fluctuates rapidly. Also, a stationary vehicle (parked or stopped at a traffic light) may be in a fairly stable signal null. A graphic

illustration is provided by recently published data taken by the Bell Telephone Laboratories at 850 MHz (Reference 66). Figure 27 shows measured received signal level as a function of travel distance on a city street, in this case a total travel distance of five meters. The spread in signal amplitude is about 30 dB, and valleys are spaced about 0.25 meters apart, very close to the transmitted wavelength. A vehicle moving at a speed of 30 miles per hour would pass through about 60 nulls per second at this frequency (850 MHz).

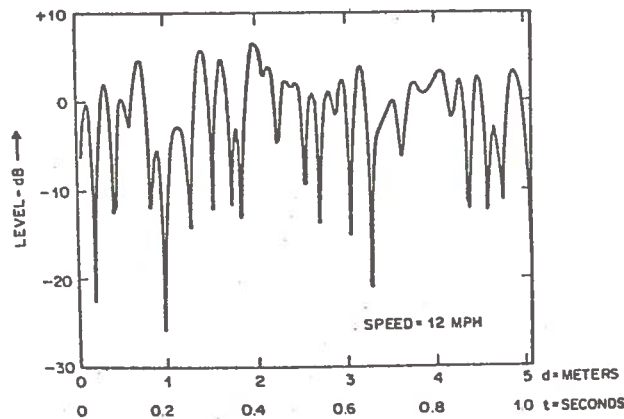

Figure 27 Typical Fading Envelope Measured at a Carrier Frequency of 850 MHz

The fluctuating signal level causes a fluctuating signal-to-noise ratio, and therefore affects the instantaneous error rate for digital modulation. Deep fade durations of 5-10 milliseconds are typically encountered, during which the error rate may be as high as one per 50 bits transmitted, or worse. Voice communications can be understood despite these few-millisecond signal gaps (or bursts of noise), but a digital message containing corrupted bits due to one or more fade periods while it is being transmitted will most likely have to be repeated, unless error correction coding is employed. At 4,800 bits per second, a 5-millisecond deep fade can affect 24 bits.

#### 4) Digital Modulation Techniques and Problems

The communication engineer must insure that the received signal strength is sufficient (most of the time) such that most fades will not cause the signal to be buried in the thermal (white Gaussian) noise. Use of high transmitter power levels is not an option in combating the multipath problem, because excessive broadcast power levels will cause interference to users of the same channel in adjacent geographical areas, and is not permitted by the FCC. The other option, that of employment of a wideband, noise-reduction communication link, is also not possible with the present channel allocations for FM land-mobile communications transceivers. To compound matters, the small channel bandwidth, and the maximum power output limitation place the standard FM land-mobile-communication transceiver near the FM threshold signal-to-noise ratio. Large signal fades can cause the FM communication system to operate below the threshold signal-to-noise ratio, and when this occurs, the received signal is significantly mutilated. In FM, this type of mutilation is commonly referred to as FM click noise. The small channel bandwidth, maximum power constraint, and a channel (especially in urban high rise areas) characterized by multipath fading, almost guarantee that as a mobile unit travels, the probability of some portion of the message being mutilated is high.

A variety of strategies and combinations therefore have been used in dealing with the multipath fades. Regarding bit rate, one strategy is to send at the highest bit rate possible without exceeding the channel bandwidth in the hope that for most of the messages, fades will be unlikely to occur while they are being sent. Another bit-rate strategy is to send the message so slowly that bit times are longer than fade durations, but in order for this to work the bit rate has to be so slow (less than 100 bits per second) that the resulting system is not very useful. In between these extremes, which is where most systems operate, there is a high probability that any message will have one or more errors, and resort must be made to redundancy and/or error-detection or error-correction coding to assure acceptance at the receiver of only messages

containing no errors. Most current systems only detect errors, and ask for repeat transmissions until an error-free copy is received. The percentage of messages received correctly without repeats is an important measure of performance for a mobile digital communications link.

All UHF land mobile transmit and receive center frequencies are spaced 25-kHz apart. The actual channel bandwidth is 20-kHz at the -25 dB level, and there is a 5-kHz guard band between channels. If a modified, standard FM land-mobile transceiver is used, then the digital data at the transceiver input must be in a form that can go through a voice filter with a 3-dB break point of 3600 Kz, and be a-c coupled into an indirect FM modulator. (Almost all voice FM transceivers use a phase modulator fed by the integrated signal. This technique is called indirect FM modulation). If the transmitter portion of a transceiver is modified in any way to obtain improved performance for digital transmission, FCC approval must be obtained.

The usual arrangement is shown in Figure 28. A one-way link is shown for clarity, but the mobile unit would usually be a transceiver. The modem at the transmitter feeds into the microphone input, or at least through the portion of the circuitry containing the voice filter. At the receiver, the modem output can be taken anywhere, and is usually taken at the discriminator to avoid filters which may be present in the audio output channel. Modulations possible include direct carrier modulation by frequency-shift keying (FSK) and phase-shift keying (PSK). The Boeing FLAIR system, for example, uses direct-carrier FSK, but this required by-passing the normal voice integrator with a wide-range integrator able to handle the maximum number of successive like bits in a message using non-return-to-zero (NRZ) coding. Almost all other systems use double modulation, i.e., submodulation of an audio carrier fed in through the normal microphone input. Common submodulations are FSK and PSK.

The different modulation techniques can be broken into two groups; those that require coherent demodulation and those that can use non-coherent demodulation. The techniques requiring coherent demodulation have lower error rates for a given signal-to-noise ratio, but require that some type of phase reference be maintained between the transmitter and receiver

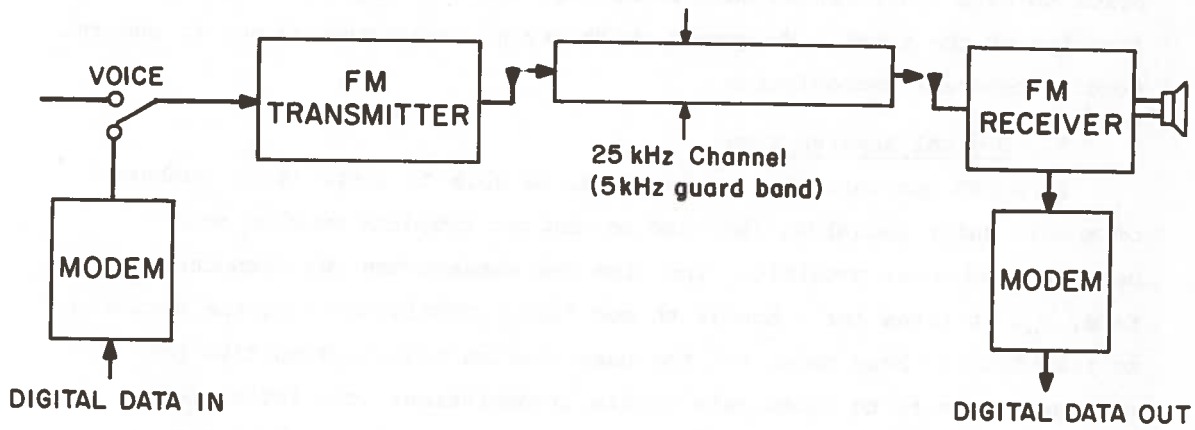

Figure 28 Digital Data Transmission via FM Voice Radios

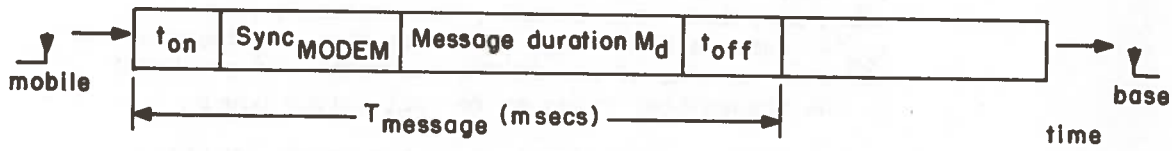

Figure 29 Time Components of a Mobile-to-Base Transmission

when sending a message, complicating the receiver. Also, the time it takes for the receiver reference to synchronize with the transmitted reference prior to data transmission adds to message time and may be a significant fraction of the total. Frequency-shift keying techniques do not in general require coherent demodulation.

#### 5) Digital Message Time

If a TRD communication system is to be able to serve large numbers of mobile units reliably, the time needed per complete message must be made as short as possible. The time per message has two components; the time,  $T_M$ , it takes for a mobile to complete transmission once the decision to transmit has been made, and the base station transmission time per message necessary to coordinate mobile transmissions (the latter does not apply in random-access protocol). A typical mobile-to-base transmission is shown in Figure 29, and has the following components:

- $t_{on}$  - The time it takes for a transmitter to come up to output power. For voice communications, this time is not critical so that in standard voice transceivers, power supplies, output stages, and antenna switching circuits can take 50-200 milliseconds to stabilize. For digital communications, the  $t_{on}$  can be longer than the actual data duration time, making inefficient use of the channel. Modifications can be made so that  $t_{on}$  can be negligible, although these modifications can be costly and difficult depending on how fast  $t_{on}$  must be made and which commercial receiver is being modified. For example, for extremely fast  $t_{on}$ 's, care must be taken to assure that no frequency components outside of the 20-Khz bandwidth are generated as the transmitter comes up to full output power.
- $t_{sync\_MODEM}$  - synchronization time, required by the modem, so that proper demodulation can occur. This is the time required for a coherent demodulator to obtain lock, i.e., for the internal data clocks to synchronize, or for other internal timing to be established (such as timing for integrate and dump demodulator circuits that might be employed in FSK). If a particular technique requires a long synchronization period, not only will the message time be longer but the possibility of going thru a fade is more likely and the entire message may be lost if a fade occurs while the modem was trying to synchronize.

$M_d$  - Message duration. This is the total time needed to send the data bits making up the message. The total number of bits includes both information bits and possible coding bits. The number of information bits depends on the type of location technique and the communication discipline used, and this will be discussed in Section C. The message duration is the total number of message bits divided by the bit rate.

$t_{off}$  - The time required for the transmitter carrier output power to fall, following shutdown, to a level that will not interfere with a succeeding transmission by another mobile. In some communications systems,  $t_{off}$  is significant (e.g., 150 milliseconds in the Orange County Communications System).

The other part of the message time per vehicle is the base transmission time necessary to coordinate the vehicle transmissions. As will be explained in Section 4.3 following, this can vary widely, depending on whether a polling or a time-slotted communications discipline is used, whether base and mobile transmissions can be overlapped in a polling discipline, whether missed mobile messages must be singled out for retransmission or ignored, and so forth. The basic base transmission has all the same time components as the mobile transmissions just described, but the message portion will usually be shorter in TRD applications where the information flow is primarily mobile to base.

Message lengths (i.e., the number of bits transmitted in the interval  $M_d$ ) are in general up to two or more times greater than the actual location data because of additional data that may be included (e.g., vehicle ID, status information) and use of message redundancy or error detection/correction coding to combat errors. The range in current systems is from 20 to 108 information bits per message.

One final comment regarding the limitations of existing voice radio designs for TRD communications is that whereas channel bandwidth is set by the F.C.C., organizations buying radio equipment for voice use do have flexibility in selecting or specifying other characteristics that will improve performance if the equipment is ever to be used for digital transmission, e.g., for TRD communications. The most important characteristics in this regard are the turn-on and turn-off times of

the transmitters, including antenna switching. Even if it costs extra to get these down to the few-millisecond range instead of the 50-100 milliseconds typically encountered, and the benefit for voice use would be unnoticeable, the investment could pay off handsomely in increased message throughput in digital service.

#### 6) Non-Voice-Channel Communications

All of the preceding has been based on use of land-mobile radios for TRD communications, which will be required in most systems. One current system, the Hazeltine pulse-trilateration AVM system, does not need communications in its basic location process, other than the wide-band (8 MHz) pulse transmission of the mobiles. For other base/mobile communications functions (status, requests, augmenting location information, etc.), 12 additional pulse times are included in each mobile transmission. These pulses follow the leading pulse on which the fixed receivers tri-laterate, and may be used for mobile-to-base messages. Similar provisions are made for base-to-mobile messages in the first half of each time slot (the measurement time for one vehicle).

With 500 two-millisecond time slots per second, the effective communication bit rate in either direction for non-location information is  $12 \times 500 = 6,000$  bps, 25% more than the fastest rate currently being obtained on a 25-kHz voice channel (by the Boeing FLAIR system).

It should be noted that in the present Hazeltine system design by far the bulk of the channel time (about 95 percent) is devoted to the communications function, and only about 5 percent is devoted to the location function. The first millisecond of each 2-millisecond time slot is for base-to-mobile messages, and 12 of the 13 vehicle pulses in the second half of the time slot are for mobile-to-base messages. The location update rate, and thus the vehicular capacity, could be substantially increased, if the communications content of the present Hazeltine format were reduced or eliminated, and some or all of the communications functions were shifted to a digital link on one or more 25-kHz voice channels. As noted above, two voice channels could easily handle the communications presently being provided, and the 8-MHz channel could then be used for up to 9,500 updates per second. This would appear to be a much more efficient use of the spectrum.



#### 4.3 Communications Disciplines

Given a digital communications channel with a particular bit rate, there are various ways to use it (communications disciplines) in a multi-user environment, and each way has advantages and disadvantages in regard to different communications parameters. In choosing a communications discipline to optimize one communications parameter of importance to a particular TRD technology (e.g., update rate in a dead-reckoning system), the designer may have accepted a performance in another parameter that is less than could be provided by one of the other disciplines, if it was unimportant in his particular application. In examining the techniques used in current systems, it is important to recognize these tradeoffs, which affect such TRD system parameters as capacity expandability, and so forth.

The three basic communications disciplines for transmitting messages from a number of mobiles to a single base station on a common channel are: time slot (TDMA), interrogate and respond (polling), and random access (sometimes called contention). There are several variations of the basic schemes. Key features of these disciplines are explained below.

##### 1) Time-Slot Systems

The first discipline is a time-slot system, in which a single base station synchronization message (not to be confused with modem synchronization as described in Section 4.3 preceding) initiates one round of responses from all mobiles. Mobiles receiving the synchronization message (some may not on a particular response cycle) start a time count. Each mobile has a different assigned time slot, and transmits its message when its counter reaches the preassigned number. Messages must be of fixed length in a time-slot system. Also, there is no way to interrogate a particular mobile, for example, to repeat a missed message, without breaking the basic response cycle, and unless extra hardware for individual interrogation has been provided. The current systems employing time-slot discipline simply ignore missed messages and look for new messages on subsequent response cycles.

The maximum vehicle capacity of a time-slot system depends on the message length and how often the user requires updates. For  $N$  time slots ( $N$  is the number of vehicles), one communication channel can report  $1/(N)(T_{\text{Message}})$  updates per second, ignoring the time taken by the base synchronization message. This is usually no longer than one vehicle response, or may be overlapped with the last mobile response if a full-duplex communications channel is employed. Once the system parameters are established and frozen into the hardware, the vehicular capacity of the channel is determined and increased capacity in a system, at the same update rate, will require additional channels.

The time-slot system is rather inflexible as regards changes in message lengths which may for one reason or another become desirable after the system is installed, since the equipment in every vehicle would have to be modified. One possibility for information that does not have to be transmitted completely in one response cycle (i.e., non-location information) is to transmit a portion of it in each of a number of succeeding response cycles, using spare bits provided for this purpose in the basic message format. This is actually done in the Boeing FLAIR system, in which only four bits of each message are allocated to status information. In order to send a two-decimal-digit 10-code, the two digits are spread over two response messages. This idea can of course be extended to longer messages, but then the inability to interrogate the vehicles for particular missed responses in the string of responses containing the message can be a problem. The probability of missing one or more portions of such a distributed message increases rapidly with message length, and many repeats of the entire message may be necessary unless error-correction coding is employed, or unless repeat of just the missing portions can be requested. If update requirements permit a very large number of mobiles in a time-slot system, there may be practical problems in maintaining time-slot synchronization over an entire response cycle. It may then be necessary to break the mobiles up into groups and code the base synchronization transmissions so that different groups respond to different synchronization codes. Such change

in an existing system may be difficult unless the hardware has been designed with provisions for change in mind.

The primary advantage of a time-slot discipline is that vehicle identification can be based on the time slot in which a vehicle transmits, and does not have to be included in the transmitted message. Also, only one base transmission is required to elicit responses from a large number of vehicles. Although vehicle identification can in theory also be omitted in vehicle messages in interrogate-and-response systems (to be described next), the danger of an erroneous response to an addressed interrogate message by the base (i.e., by the wrong vehicle) is such that non-time-slot systems have a vehicle identification (ID) code in all vehicle messages in order to detect false responses. There is a false-response probability in a time-slot system, but it is much less than in an interrogate and respond system. A random-access system obviously requires an ID code in each vehicle message, otherwise the base would not know which vehicle was transmitting. The time-slot discipline thus has the shortest message lengths, other things being equal. But this must be balanced against the rigidity of the format and the mobile transmission sequence.

## 2) Interrogate-and-Respond Systems

In the interrogate and respond, or polling, discipline, a base interrogation message is sent out for each desired vehicle response, and a vehicle responds only when it receives an interrogation message containing its own vehicle ID code. The same interrogation message is, of course, received by all vehicles and as explained above, there is a possibility that through errors in receiving the ID code, another vehicle may respond together with the addressed vehicle, or in place of it if the right vehicle missed the interrogation. In the former case, the responses interfere, a situation which the base can usually detect reliably. In the latter case (only one response is received but from the wrong vehicle), the base must depend on the ID code to reject the erroneous message. In either case, the base usually repeats the interrogation until it received an error-free response containing the right ID code, or until it decides that the addressed vehicle is not communicating. This last

decision is usually based on a set number of unsuccessful re-interrogations. Even if an erroneous response is somehow accepted by the communication logic, it can in some cases be detected in data processing through tests for physical reality in the apparent vehicle motion since the last update of the addressed vehicle, but it is much more desirable to catch erroneous responses before they get that far. If updates are very infrequent (as they are in the Huntington Beach AVM system), the physical reality test is not possible. It is thus usual in interrogate-and-respond systems to provide error detection or correction coding for the vehicle ID code in both base and mobile messages.

An advantage of the interrogate-and-respond discipline is that interrogation sequences can be completely flexible. For example, different vehicles in a mixed fleet (e.g., police, taxi's, trucks) can be updated at different rates appropriate for their individual TRD requirements instead of all at the same rate. Also, vehicles can be updated on the basis of the area they were in on previous responses. An obvious application of area-update would be in police or taxi dispatching, where only vehicles within a given radius of a call need be considered. Both of these possibilities work toward larger vehicle capacity for a given message rate.

Another advantage of the interrogate-and-respond discipline is that message lengths can easily be made flexible, even to the point of having different message lengths and formats for different classes of vehicles in a mixed-fleet situation. Of course, flexibility in this regard usually implies some message overhead in the form of control bits or codes to permit proper message interpretation at the receiver. Most mobile digital terminals designed for police communications have adopted the ASCII code conventions and work just like the usual computer terminals designed for telephone-line use, using delineator characters to signal start of heading (SOH), start of message (SOM), end of message (EOM), etc. The tradoff to be made in designing a particular system is the bit efficiency of fixed formats, which may later prove to be insufficient for expansion or unforeseen needs, versus the penalty in carrying extra bits to provide flexibility. In this regard, it is noted that information

needs do not always have to go up: some users may require less information than provided in a fixed format and could thus use shorter messages in a flexible communication system, improving efficiency. These issues will be of particular importance in designing multi-user TRD systems, as compared to the present situation in which TRD systems are being installed on a single-user basis.

The interrogate-and-response discipline also fits in well with an acknowledge/not-acknowledge strategy for handling messages in which errors are detected. Time permitting, both the base and the mobiles can retransmit as necessary to complete a particular message, if that is required. One strategy is the positive ACK/NAK response in which retransmission takes place if an acknowledgement message (either ACK or NAK) is not received within a given time. The other (negative) strategy assumes that the message went through unless a NAK or a request for retransmission is received. Since messages may be lost in either direction, the positive ACK/NAK strategy is more foolproof, but requires more channel time because of the extra transmissions needed to implement it. The negative strategy appears more suitable for routine TRD operation, since it takes less channel time, and action regarding missed or garbled messages is controlled at one end of the link (the base). A positive ACK/NAK strategy becomes more important in random-access (contention) disciplines where control of message initiation is dispersed in the mobiles, as will be explained further on.

The one-for-one base/mobile message ratio required in the interrogate-and-respond discipline may be of concern in some situations. If a half-duplex channel is used (the base and the mobiles all transmit on the same frequency), the base transmission time in requesting a response adds to the mobile transmission time in determining the total transaction time for updating one mobile. However, if a full-duplex channel is used, e.g., a UHF "channel" in which the base and the mobiles transmit on different frequencies, the interrogation of a new mobile may be overlapped with the response from the mobile previously interrogated. This is done in the Teledyne Loran-C AVM system, as will be explained in more detail in Section 4.4, with the result that there is no lost time between mobile responses.

Another area of concern in large-capacity TRD systems in which some mobiles may not be interrogated very often is what to do about non-location messages that the mobile may wish to originate, such as an emergency call for help. In a straight interrogate-and-respond system, there would be no way to send such a message until the mobile was next polled, and this might take several minutes in a large multi-user system. A suggested way around this is to make a hybrid system combining some aspects of all three disciplines. For example, if the base interrogations are time-slotted so that there is an open period for mobile-initiated transmissions every second or so, a mobile having an emergency message could use the random access discipline to transmit its message during the next such open period. The identification of this period could be either by the mobile's determining that the base has not transmitted for a set time since the last interrogation, or the base might transmit a special code or signal to indicate that it is now listening for mobile-initiated transmissions. The latter would appear to be the better method. The question of what to do if more than one mobile transmits simultaneously in such a situation will be discussed next.

### 3) Random-Access Systems

The final discipline to be discussed is random access (or contention). In this discipline, transmissions are initiated by the mobiles, and there is the problem that two or more mobiles may try to transmit at the same time, either because they all detect at the same time that the channel is clear, or if there is no detection mechanism, because they don't know that another mobile is already transmitting. The latter case can arise in full-duplex UHF channels because the mobile receiver is tuned to the base channel, not the mobile frequency. Even if the mobiles could listen to the mobile transmit frequency, they would not always be able to hear each other because without one of the antennas being elevated (as it is for the base), the effective range of mobile-to-mobile transmissions is less than that between any mobile and the base. To provide a "channel in use" indication for UHF systems, or mobile-to-mobile communication, it is common in voice

systems to have the base repeat any message being received from a mobile, or at least turn on its carrier for the duration of the mobile transmission. Mobiles can then tell when no other mobile is transmitting by monitoring the base transmitter. Many mobile transceivers have a signal output called "carrier detect" for this purpose. This can be used to prevent mobiles from starting a transmission when the channel is in use, but does not prevent two or more mobiles from starting transmission as soon as the carrier detect line goes off.

Simultaneous transmissions of the sort just described will interfere with each other, and in many cases, the base will not even know which mobiles were trying to transmit, so it can't address a request to them for retransmission. This is where the positive ACK/NAK strategy is important. A mobile not receiving either an ACK or a NAK in response to its message must retransmit, even though the base may have correctly received the message and it was the base ACK response that was lost! However, some method must be used to prevent conflicting mobiles from again conflicting on retransmissions. The usual method is to use different retransmission delays in different mobiles. With these delays in effect, some other mobile may of course get in first, but conflict situations should not result in endless repetitions of the same conflict.

The random-access discipline has advantages in certain TRD situations, particularly for proximity systems if one only wants to know when a mobile first reaches a proximity device and is not trying to determine locations in between. This was the type of communications discipline used in the now-abandoned Montclair, California AVM system -- whenever a mobile detected a signpost is transmitted the signpost code repetitively until reception was acknowledged by the base. It then did not transmit again until it detected a different signpost code, i.e., had traveled the distance to another signpost. This low level of TRD transmission activity is of particular value if one is sharing digital and voice transmissions on a common channel, as was the case in Montclair. A time-slot or interrogate-and-respond discipline would have kept the channel busy with messages which only occasionally contained new location information.

#### 4) Error Control

The final topic in this section is error detection. As has been indicated in previous discussions, the probability of errors in mobile digital communication is fairly high and some effective means must be provided for the base or a mobile to tell that a received message contains one or more errors. A variety of methods is in use in current TRD and mobile digital terminal systems, and includes multiple repetitions of each message for bit by bit comparison (100 percent redundancy or greater), cyclic error check coding, error correction coding, confidence tests on the received r-f energy for each bit, and some hybrid combinations among them. The methods used in several current TRD systems will be described in Section 4.4 following. Methods used in several non-TRD applications are briefly described below.

In its Mobile Digital Terminal (MDT) systems, Motorola employs double framing of each message, i.e., each message is repeated once and both copies are discarded if they do not agree on a bit by bit basis. Alternately, the received message may be displayed with each erroneous character code displayed as an asterisk (\*) to see if the meaning can still be determined despite the missing character(s). This can often be done for text messages, but is of little help if an error is made in a string of numbers. It also works only with human interpretation; information fed into a computer has to be right in every respect. The Motorola systems use a positive ACK/NAK strategy and automatically attempt retransmission up to a set number of tries (usually five) before alerting the operator that there is a problem. The double transmission is done on a bit inter-leaving basis, with a 64-bit offset between the two message copies. At the transmission rate of 2400 bits per second, this provides a 26.7-msec. offset between like bits, which is more than the usual fade duration, minimizing the probability that like bits will be clobbered by the same fade, and at the same time requiring only a 64-bit shift register to implement the comparison. Motorola MDT terminals have demonstrated 97 percent mess-



age completions in the Chicago Police system, including up to five automatic retries (see Appendix A). Information on the average number of retries for each completed message has not been available.

The Bell system, in its cellular mobile radiotelephone system being installed in Chicago, is following a somewhat different approach for the short digital control messages that are used to initiate calls and switch channels as a mobile moves from cell to cell. Bell is using a wider channel than is available in the land-mobile services (30-kHz IF bandwidth) and is transmitting 10,000 bits per second, Manchester coded to prevent a problem with long strings of like bits exceeding the dynamic range of the integrator preceding the phase modulator in the voice radio. This, of course, doubles the number of bit transitions to 20,000 per second. The designers of this system have been very concerned with the fading problem (Reference 66), particularly at this transmission speed, and have decided to repeat each message five times, with majority voting on a bit-by-bit basis. The net bit rate is thus 2,000 bits per second.

Other mobile digital terminals with which the authors are familiar employ just character parity, or parity in combination with a cyclic block check code. One worries more about the ID code portion of the message and double-frames it, but not the rest of the message. Some of these terminals have been reasonably successful in routine operational use in law enforcement and transportation applications, however the total number of such installations is not large (probably not more than 100), and many of these are in reality small-scale tests. Also, the radio propagation environments of the installations vary widely, and what may work well in an easy environment (say a small city with no tall buildings) may not work in a difficult environment like the high-rise area of a large city. More operating experience in a variety of environments would seem to be required before some consensus can be reached as to how the various parameters of TRD communications systems should be chosen.

#### 4.4 Typical TRD Communications Systems

In order to illustrate differences in approach to the mobile digital communications systems parameters discussed in the preceding sections, details on three current TRD communications systems transmitting digital data over voice-radio equipment are presented. These are typical of the current state of the art, and vary in such characteristics as bit rate, update rate, means of protection against errors, and degree to which the standard voice radio equipment is modified to reduce limitations on digital performance. Each of these systems was designed for use with a different basic TRD technology, and this has, of course, influenced choice of parameters, as will be explained. A current TRD communications system not employing voice radio channels is also described, and finally, a comparison is made between these four TRD systems (including communications) in terms of spectrum utilization.

##### 1) Boeing FLAIR System (Dead-Reckoning TRD)

The FLAIR\* system installed in St. Louis is using the highest bit rate (4,800 bps.) of any TRD system operating on a voice channel, or for that matter, any current mobile digital terminal system. Since it also does not use any redundant coding for error control, sends very short messages (20 bits) in a time-slot discipline, and has reduced the transmitter  $T_{on}$  and  $T_{off}$  times by equipment modifications, it has by far the highest message rate (177 per second) of any current TRD digital communications system operating on a 25-kHz voice-radio channel.

The high message-rate requirement is tied in with the operating parameters of the dead-reckoning TRD system. There are, of course, tradeoffs to be made in the resolution of the odometer and heading readouts, the number of resolution elements per message, and the time between messages from each vehicle. Boeing has elected to use a 1.25-second update interval for each vehicle, and to transmit incremental information in each message, i.e., the changes in distance and heading in the preceding 1.25 seconds. This has permitted encoding the TRD information into a total of 13 bits, 7 for distance and 6 for heading. Three bits are also included for emergency flags and four bits for status code, for a total of 20 bits per message.

The modulation used is direct-carrier FSK (FLAIR is the only current system not using sub-modulation). Since FM radios use indirect FM modulation, this requires feeding ramp inputs, the integral of the baseband

---

\*Trademark.

non-return-to-zero (NRZ) digital signal, into the phase modulator. This integration function is provided in the normal voice input channel, but does not have the dynamic range to handle long strings of consecutive like bits, thus Boeing designed a wide-range integrator and secured FCC approval to by-pass the normal integrator in the standard voice radio employed. As was explained in the previous section, the Bell System is avoiding the necessity of this particular modification in its cellular radio-telephone system by using Manchester coding (a positive-negative pulse sequence for a "one" and a negative-positive pulse sequence for a "zero"), but this doubles the channel bit rate for a given information rate. At the FLAIR information rate of 4,800 bits per second, the channel rate with Manchester coding would be 9,600 zero crossings per second, 10-dB down on the skirt of the 3-kHz modulation filter required by the FCC.

Boeing does, however, send a short burst of nine bits at 9,600 bps. as a decoder synchronization signal at the start of each message, taking 0.9375 milliseconds. This is working operationally, but as mentioned in an earlier section, Boeing, among others, has applied to the FCC for relief from the 3-kHz filter requirement. The filter restriction was revised recently by the FCC for police and fire services (see Section 4.5).

Boeing is using an RCA transceiver, and has modified the transmitter to reduce the  $T_{on}$  and  $T_{off}$  times to less than one millisecond each. Since spurious emissions (outside the assigned channel) can be created in turning a transmitter on and off, these modifications required FCC approval. A typical  $T_{on}$  for an unmodified voice radio is 50-150 milliseconds (ten or more times the total message time in the FLAIR system), thus the need for this modification.

As regards error protection, Boeing has elected not to use redundant coding, which would have increased the number of bits per message, reducing the number of vehicles that could be handled in the 1.25-second update interval. The error-detection method used is to examine the r-f energy in the receiver i-f amplifier on a bit-by-bit basis, and reject any bit which falls below a pre-set energy threshold. This provides protection against erroneous bits which may be generated by multipath fading. The tracking algorithm in the computer can miss up to four consecutive messages per

vehicle without losing track, so simply rejecting bad messages is a feasible mode of operation, so long as the rejection rate is not too high. The computer also rejects received messages which pass the r-f energy check, but still have errors. This is done by checking the amount of change in distance or heading in the 1.25-second update interval against the slopes of the previous track.

The FLAIR time-slot system is organized as follows. The base station sends out a 66-millisecond synchronization signal, and the vehicles then respond in 200 time slots of 5.625 milliseconds each. A vehicle response includes 0.52085 milliseconds of  $T_{on}$  time, 0.9375 milliseconds of 9,600 bps synch signal, and 4.375 milliseconds of data (20 bits at 4,800 bits per second), for a total of 5.625 milliseconds. The time slot identifies the vehicle, and no ID bits are included in the response message. A guard time of 59 milliseconds follows the base synchronization signal, before the first response. The base synchronization signal and guard time thus take a total of  $66 + 59 = 125$  milliseconds, or 10 percent of the 1.25-second update interval. The synchronization transmission cannot be overlapped with the vehicle responses to eliminate this 10 percent because the last 20 vehicles in the time-slot sequence would miss part of it while they were transmitting.

The FLAIR system sends 177 messages per second on a 25-kHz channel, or 7,080 messages per second per MHz. The bit rate of 4,800 per second yields 192,000 bits per second per MHz. Despite these high numbers, the system is limited to 200 vehicles per radio channel because of the high update rate required to perform dead-reckoning tracking with incremental information. FLAIR has had no problems operating in St. Louis, which is a low-rise city, with a single base transmitter/receiver site. The system is designed to accommodate satellite receivers if they should be necessary in a more difficult environment. The base computer will track up to 1,000 vehicles, but that will require five radio channels with 200 vehicles each.

One disadvantage of operating entirely with incremental information is that if a vehicle goes out of communication for any length of time, it is usually impossible to reestablish the track and the vehicle must be reinitialized. This could be done from any location by voice radio, but operationally, FLAIR has established a number of reinitialization points that can be communicated to the computer by push-button codes. Vehicles for

which track is lost are displayed on the dispatcher's screen and he informs the vehicles, which then go to the nearest reinitialization point and send a signal to the computer. Possibilities for making this process more automatic are discussed in Section 3 and in Appendix A, Paragraph 8.

## 2) Teledyne System (Loran-C TRD)

The Teledyne Loran-C AVL system has not yet been implemented on an operational basis in any urban area, but has been tested in various cities (not all of these tests have involved the communications system). Teledyne is using an interrogate-and-respond communications discipline, with the interrogation (poll) for each vehicle overlapped with the response from the previous vehicle. The total message time from one vehicle to the base is 120 milliseconds, giving a message rate of 8.33 per second. The base poll takes only 47.5 milliseconds, and overlaps the end of a vehicle response.

Teledyne is also using RCA transceivers, modified to shorten the  $T_{on}$  and  $T_{off}$  times. The modifications were developed independently of the Boeing modifications previously described, and are not nearly so effective. For example,  $T_{on}$  is 16.67 milliseconds, compared to 0.52 milliseconds for Boeing. Phase-shift keying (PSK) of an audio carrier is used (submodulation), and the data rate is 1,200 bits per second. Teledyne uses an error-correcting code with a redundancy of 71 percent. In one format for which information is available, the data portion of a message consists of 108 bits, made up of nine 12-bit characters. Each character consists of seven information bits and five Hamming-code check bits. This 7/5 Hamming code will detect two errors and correct one error, per character. The  $9 \times 7 = 63$  information bits include vehicle ID, two Loran-C time differences, status, and augmenting TRD information. (Depending on the number and type of augmenting devices used in a particular application -- proximity, odometer, turn indicator -- the message length used may be different than that just described.) Twelve message characters take 90 milliseconds at 1,200 bps.

There is a decoder synchronization preamble in each message, consisting of 16 bits (13.33 milliseconds). This, plus the 16.67-millisecond  $T_{on}$  and the 90-millisecond data time adds up to 120 milliseconds per message, or a rate of 8.33 messages per second. Teledyne can thus update 500 vehicles per minute, not counting repeat polls for missed messages. On a spectral basis, Teledyne sends 333 messages per second per MHz, and 48,000 bits per second per MHz.

Although its message rate is only five percent of that in the FLAIR system, the Teledyne system can easily handle 500 vehicles per channel, if one-minute updates are permissible, as the analyses of Section 2 indicate is so for most applications. If Teledyne were to operate at 4,800 bits per second and further reduce  $T_{on}$  as Boeing has done, the capacity could be as high as 2,250 vehicles per channel at a one-minute update rate, compared to the maximum 200 vehicles per channel for FLAIR. These higher capacities per channel are, of course, a result of using a TRD technology which transmits absolute, rather than incremental, position information, and has no minimum update rate requirement for TRD operation.

### 3) Hoffman System (Proximity TRD)

The Hoffman AVM system, presently in operation in Huntington Beach, California, is similar in many ways to the Teledyne system just described: its data rate is 1,200 bits per second and it uses the interrogate-and-respond discipline (although random-access, or contention, operation is also possible). It differs, however, in message formats, error-detection coding, and in using frequency shift keying (FSK) submodulation. The two tones used are 1,200 and 1,600 Hz.

The data in the Huntington Beach transmissions consists of 32 bits, including vehicle ID, 14 bits of signpost code, and status and emergency flags. These 32 bits are double-framed (repeated in each message) so that the base can detect errors by comparing the two copies. A message in which the copies do not agree is rejected and the vehicle is re-polled. The signpost code is in the form of two 7-bit numbers, one for E-W coordinates and the other for N-S coordinates. It is noted that this would code 16,384 signposts, more than any system is likely to have. If transmission time were of more concern than it is in the Huntington Beach system, a straight numerical code would be more efficient.

The decoder synchronization preamble consists of five bits, taking 4.2 milliseconds to transmit. The 64 information bits (32 bits, double-framed) take 53.3 milliseconds. With reasonable  $T_{on}$  and  $T_{off}$ , these times would indicate a message rate of about 15 per second. This is not possible, however, because of the constraints imposed by the Orange County coordinated communications system. The AVM system operates on the Huntington Beach voice channel, which as will be described, has a  $T_{on}$  of 35 milliseconds and

a  $T_{\text{off}}$  of 150 milliseconds, for a total of 185 milliseconds. It proved possible to overlap  $T_{\text{on}}$  and  $T_{\text{off}}$  somewhat between adjacent messages, reducing the gap between messages to 157 milliseconds, for a  $T_{\text{message}}$  total of  $4.2 + 53.3 + 157 = 215$  milliseconds. The base polls are overlapped, so the message rate is  $1/.215 = 4.65$  messages per second, about half that of the Teledyne system despite a data message half as long.

The spectral figures for the Huntington Beach system are 186 messages per second per MHz, and 48,000 bits per second per MHz. With reasonable  $T_{\text{on}}$  and  $T_{\text{off}}$  times, the system would send about 15 messages per second and 600 messages per second per MHz.

Orange County has organized the communications for its 23 communities and other county-wide organizations into a common system. Six channels are shared among the 23 communities for their local police department use. The Motorola Micor radios used have private line features, and it is this tone signalling that causes the problems in  $T_{\text{on}}$  and  $T_{\text{off}}$ , in addition to the characteristics of the Micor radios themselves. No modifications of the radios or of the private line signalling were possible in this installation. The Orange County setup includes extensive repeating of channels for county-wide coverage, and alternate control by a centralized county dispatcher, so nothing could be done that would upset the existing system.

Partly because of the shared use of the city voice channel and partly because of the mode of dispatch operation in Huntington Beach (see description in Section 2, vehicles are polled for position only when there is a dispatch to be made. Even at the slow polling rate (4.65 vehicles per second), polling the vehicles assigned to beats near an incident still takes only a second or two, which is fast enough for the purpose. The capacity would, however, not be sufficient for a larger city or a multi-user TRD system. With a better communications setup (a dedicated digital channel and minimal equipment constraints), the Hoffman system would update about 1,800 vehicles every two minutes, 80 percent more than the Teledyne system. Other things being equal, the difference is in the message lengths -- 64 bits for Hoffman versus 108 for Teledyne. As has been mentioned, the Hoffman messages could be shortened by about eight bits if signposts were encoded more efficiently, improving its capacity advantage still more.

#### 4) Hazeltine System (Pulse Multilateration TRD)

The Hazeltine system has already been described in Paragraph 6 of Section 4.2 (page 124). The purpose of the present discussion is to present the spectral data for comparison with three voice-channel systems just described. The system uses about 6 MHz of an 8-MHz channel for combined location and communication functions, compared to 25-kHz channel(s) for the other systems.

As previously noted, Hazeltine transmits 500 12-bit messages per second, appended to the response pulses which the base uses to determine location. No error coding is used, but the system has an inherent error detection capability in its multiple receptions of the transmitted information. Since vehicle transmissions are received at a minimum of three fixed receiving sites, the three (or more) copies received can be compared for error-detection purposes. Messages from the base to the vehicles (in the first half of each time slot) do not have this error-detection feature.

With 500 vehicle responses per second and an 8-MHz bandwidth, the spectral utilization of the Hazeltine system for the communications function is 62.5 messages per second per MHz, and 750 bits per second per MHz. These figures are considerably smaller than the 25-kHz systems just described, particularly in the bit rate per MHz. Although the Hazeltine system can handle  $500 \times 60 = 30,000$  TRD updates per minute, despite using 95 percent of the channel time for communications, and this is as large a capability as any TRD system is likely to need, the Boeing FLAIR system could update 56,640 vehicles per second in a comparable bandwidth, and provide seven non-location information bits per response. As pressures on the spectrum increase, the allocation of 8 MHz for TRD systems serving a few hundred vehicles may be open to question.

#### 5) Communications Systems Comparisons

Table 5 summarizes the communications system parameters for the four TRD communications systems just described. Note that the Boeing FLAIR system has a vehicular limit of 200 per channel imposed by the update rate requirements. Also that less than half the time in the Hazeltine system is available for mobile-to-base messages. These messages are, however, entirely available for non-TRD information.



Table 5 - TRD Communications Systems Comparisons

Company	Location Technology	Communications Discipline	Bandwidth	Message Length (bits)	Bit Rate (bps)	Messages per sec.	Messages per sec. per MHz	Bits/sec./Mhz	Veh. per min.
Boeing	Dead Reckoning	Time Slot	25 kHz	16	4800	177	7080	192000	200*
Teledyne	Loran-C	Interrogate & Respond	25 kHz	108	1200	8.33	186	48000	500
Hoffman	Proximity	Interrogate & Respond (& Random)	25 kHz	64	1200	4.65	333	48000	279
Hazeltine	Multi-lateration	Time Slot	8 MHz	12	13000	500	62.5	750 <sup>#</sup>	30000

\*Limited by the 1.25-second update requirement

<sup>#</sup>For the mobile-to-base slots. This would be 1625 if the base-to-mobile slots were also included.

#### 4.5 Possibilities for Improved Digital Communication Links

Over the past 8-10 years, digital communication on voice channels in the land-mobile radio service has progressed from about 100 bits per second in early teleprinter experiments to a range of 1200-4800 bits per second in currently operational TRD and mobile digital terminal systems. The preceding sections have indicated, however, that communication is still likely to be the limiting factor in large-scale application of centralized TRD techniques. Assuming that about 150 bit times are typically needed per update in the interrogate-and-respond mode that would probably be used in a very large system, these data rates will handle 400-1600 vehicles per channel if the update rate is once per minute and 20 percent of messages require repetition due to missed polls, errors, etc. Since little or no further improvement in data rate can be expected on a land-mobile channel as presently defined by the FCC, greater vehicle capacity in a TRD system can only be obtained by using multiple channels, with each channel handling a different part of the vehicle fleet. The channel capacity is even smaller for some TRD techniques. As has been described, the Boeing FIAIR system is currently operating at 4800 bps (the fastest of any), but must update at 1.25-second intervals because of the incremental nature of the transmitted dead-reckoning TRD data. It thus requires a separate channel for every 200 vehicles.

One question that has been examined in this study is whether the present FCC land-mobile channel specifications that have developed over time for voice use, and for which all available radio equipment is designed, are necessarily the most spectrally efficient way of transmitting digital data if multiple channels must be used to achieve a desired system capacity. That is, would there be a spectral use advantage in creating wider channels for solely digital data transmission at high data rates? This would of course be difficult in the 450-MHz (UHF) band because of the present high channel usage, but there is the possibility that special wide channels for TRD digital transmission could be created in the new 900-MHz land-mobile allocations. The FCC has already created two 8-MHz channels there for pulse multilateration TRD systems.

The thought that wider channels would be more efficient spectrally comes from the fact that a substantial portion of the present 25-kHz land-mobile channel spacing in the UHF band is taken up by guard bands to pre-

vent adjacent-channel interference. Given that about 4,000 Hz is the highest modulating frequency that needs to be transmitted for satisfactory voice reception, the FCC limits FM deviation to 5 kHz, and requires that at 10 kHz from channel center, any emission must be at least 25 dB down from the mean power of the unmodulated carrier. It further requires that prior to modulating the carrier, the baseband information signal (analog or digital) be attenuated at a rate of at least  $60 \log f/3$  dB above 3 kHz, where  $f$  is in kilohertz. At 10 kHz, this modulation attenuation is 31.4 dB, 6 dB more than the emission limitation. The 10-dB points of the modulation filter are  $\pm 4.4$  kHz, effectively setting the usable channel width as 8.8 kHz, 35 percent of the 25-kHz channel spacing. The result is that the best current ratio of bits per second to Hertz of channel spacing in an operational land-mobile data transmission system is 0.2 (4800/25000). Assuming that band-edge roll-off slopes can be the same for wider channels, the modulation rate can become a higher fraction of the channel-to-channel spacing as the latter is increased.

It is of course realized that there are many factors in mobile radio transmission that make high-speed digital signalling a less certain affair than on wire lines, the most prominent ones being multipath propagation and impulsive noise interference (Reference 74). Multipath causes signal fades up to 20-30 dB which vary the signal-to-noise ratio at the receiver. This, of course, affects channels of any width, but at some point as channel width is increased, fading tends to become frequency-selective, additionally causing distortion of the modulation. Multipath also causes delayed echoes of the transmitted signal which lead to intersymbol interference when the echo delay time becomes a significant part of the bit time. Thus intersymbol interference becomes more likely as the digital bit rate is increased. These propagation factors clearly place limits on bandwidth and digital signalling rates in land-mobile transmission, but it would seem to be sheerest coincidence if the present FCC channel specifications designed for 3-kHz voice transmission also yield the most efficient digital transmission per unit bandwidth, given the different nature of digital signals and the possibilities for optimal waveform design, matched-filter reception, and so forth.

The modulation filter limitation described above was very recently

modified by the FCC (for the Fire and Police Radio Services only) to permit better use of the present channels for a newly emerging technology -- digital voice scramblers. These systems, being developed by various vendors, require digital rates of 12-15 kbps to encode speech with acceptable quality for the public safety agencies that would use them, and the vendors appeal was that they could live with the 25-dB emission limitation at 10-kHz off carrier if the requirement for the standard audio low-pass modulation filter now specified by the FCC were removed. Boeing also requested removal of the filter requirement for its AVM system because, as was described in the preceding section, it uses a short burst of 9600 bps as the decoder synch preamble for its FLAIR system. The FCC started consideration of requests in Docket No. 21142, March 23, 1977 (Reference 67), and replaced the low-pass audio filter requirement with new sideband emission rolloff requirements effective February 23, 1978 (Reference 61). The new standards apply only to the Fire and Police Radio Services, and only to F3Y (FM digital voice) and F9Y (FM digital modulation) emissions.

As shown in Figure 30, the new emission rolloff standard starts at 5 kHz off-carrier, intersects the 25dB @ 10-kHz point described earlier, and then changes to a steeper slope that is 60 dB down at 20 kHz off-carrier. The attenuation can shift to a constant dB value of  $50 + 10 \log_{10}(P)$  whenever that value is less than  $116 \log_{10}(f_d/6.1)$ , which obviously cannot occur at attenuations less than 50 dB. For a 25-watt transmitter, the transition to a constant attenuation limit would occur at -64 dB. This emission rolloff above 10 kHz off-carrier is much more stringent than the standard levels of 25 dB or greater from 10-20 kHz off-carrier, and 35 dB from 20-50 kHz off-carrier, that are required for 20-kHz bandwidth voice channels, and is obviously intended to insure minimal audible crosstalk of F3Y or F9Y digital signalling tones into adjacent channels. Information on the technical problems in meeting these new sideband rolloff requirements when the low-pass audio filter is removed has not been obtained in the present study.

Although the audio filter and new sideband attenuation curves have been juxtaposed in Figure 30 for illustration, they are not strictly com-

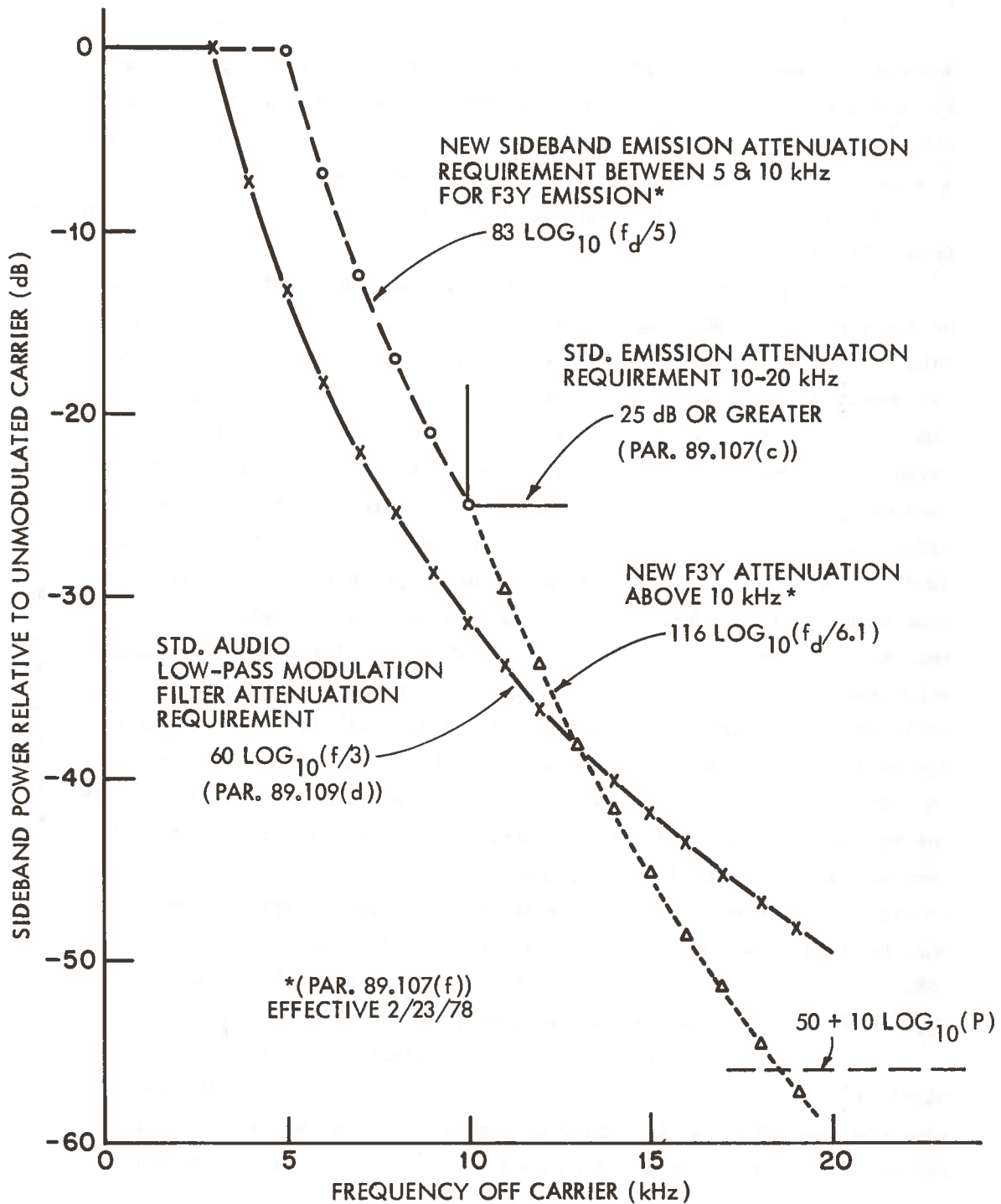

Figure 30 Comparison of Standard Audio Low-Pass Filter and New Emission-Attenuation-Based Rolloff for F3Y Digital Modulation

parable for spectrum definition purposes because the audio filter does not completely define the sideband emission of an FSK transmitter (which also depends on the deviation frequency, the modulation index, and the shaping of the baseband data pulses). Other things being equal, however, it is clear that a number of dB have been gained for modulating frequencies from 4-11 kHz.

It should also be noted that digital voice applications (scrambled or unscrambled) do not require the same signalling reliability as digital data. Removal of the voice filter does not widen the channel all that much, and modulation sidebands 10 kHz off the carrier must still be 25 dB down, limiting the effective channels width to less than 20 kHz. The fact that these organizations feel that digital modulation rates up to 15 kHz are feasible at all under the circumstances lends credence to the thought that wider channels for digital data should be seriously investigated. One further piece of evidence is that the Bell System has settled on 10-kHz data transmission in the 30-kHz channel spacing of its cellular radio-telephone system now being installed in Chicago. Actually, the channel zero-crossing rate is 20,000 per second, since Manchester coding is being employed. Information obtained from Mr. J.I. Smith of the Bell Laboratories (one of the authors of Reference 66) is that in this system, the FM deviation is 8 kHz, and the baseband roll-off filter is flat to 10 kHz. The measured spectrum of the transmitted signal is flat to 10-kHz off carrier, and is 30-dB down at 16-kHz off carrier. Thus, their channel is effectively about 50-percent wider than the land-mobile channels, which must be 25-dB down at 10 kHz off carrier. Bell is using direct-carrier FSK, feeding the Manchester-coded digital signal into the normal voice-input channel of its mobile transceivers.

If a 50-kHz channel were created for digital data transmission (equivalent to two present 25-kHz land-mobile channels), bandwidth considerations indicate that it should be possible to send at least 20,000 bits per second reliably, and perhaps more. This would be an improvement of

two-to-one in spectral utilization, resulting from the elimination of the present guard band between two adjacent channels. One might also think about even wider digital data channels, which could yield even more improvement on a spectral basis. Bandwidth is not the whole story, however, The most serious limitation on bit rate in land-mobile transmission appears to be the echo problem and the resulting inter-symbol interference. The literature has been carefully examined on this question and it seems clear that although strong echoes seldom exist with a delay time of more than about 3-5 microseconds, weaker echoes commonly exist out to 10 microseconds, and occasionally to 20 microseconds. This would place an upper bound on bit rates at somewhere between 30 and 50 kHz. Another problem with echoes is that they appear to the FM discriminator as interfering signals, and even though the FM capture effect makes the strongest signal (presumably the first energy received) predominate, the echoes cause very high frequency spikes in the discriminator output (Reference 75). These spikes can be reduced by wide-band discriminator designs, but the required bandwidth and dynamic range are considerable. For example, for an interfering signal of ratio  $q$  to the desired signal, the dynamic range required in the discriminator is  $1+q/1-q$ , and the discriminator bandwidth must be larger than the i-f bandwidth by the same ratio. For a  $q$  of 0.9, the ratio is 19, yielding a discriminator bandwidth of 570 kHz for a 30-kHz channel. There are ways around this, however. One strategy is to cascade successive hard limiters and filters of lesser bandwidth. The point is that for voice-radio designs, these measures to improve capture have not been necessary, and digital data transmission on voice radio equipment suffers thereby. Attention to building an optimum receiver, or at least as optimum as could reasonably be obtained, would be an obvious requirement in designing a wide-band, high-speed digital data link for land-mobile use.

In summary, considerable thought was put into the wide-band question during the study, and opinion was sought from every company contacted. Some had not really thought about the question, being too busy designing equipment for the present channels. Others thought that there was a good potential for transmission at higher rates on wider channels, perhaps as high as 30 kbps, but also had not done specific studies because no immediate need was in sight. There would appear to be a rationale for some government agency establishing needs and sponsoring research in this area.

## 5. CONCLUSIONS AND RECOMMENDATIONS

### 5.1 Conclusions

Applications of automatic vehicle locating techniques that appear to be cost effective have been identified in the dispatching of police patrol cars, ambulances, taxis, trucks, and paratransit vehicles such as Dial-A-Ride buses; in the regulation of headways along a fixed bus route; in the control of aircraft on an airport surface; and in providing security for persons and property in various transportation modes. The operational requirements for each specific application have been estimated and we have concluded that any of the four basic TRD techniques now available (Proximity, Multilateration, Dead Reckoning, and Hyperbolic) is capable of providing adequate service in an urban area. Deficiencies peculiar to each candidate can, in most cases, be overcome by employing hybrids. When consideration is extended to applications involving aircraft and vessels, the only AVL method that appears to satisfy the needs of all the potential users is Loran-C because of its combination of country-wide coverage, accuracy, and non-saturability. Even Loran-C, however, would have to be augmented by backup position determination devices in a few locations, such as high-rise urban areas, where the loss or distortion of signals is a problem.

It is clear that many important technical and operational questions must still be resolved before widespread implementation of AVL systems is warranted. These are discussed in the following review of individual applications along with suggestions on research programs, field tests, and demonstration systems that could be initiated to provide the data necessary for sound policy decisions. All the applications utilize TRD techniques as part of a centralized computer-based command and control network and the integrated functioning of the overall system must be considered in evaluating cost effectiveness. In particular, we have found that providing adequate digital data communication capacity and coverage to service multiple users will probably be the limiting factor in the performance of most installations. Intensive additional research and development in the area of mobile digital communications, therefore, is required. Significant improvements are also possible in the functional



characteristics and price of current Loran-C equipment and in combining the position information derived from this primary system with data from backups such as signposts and dead reckoning.

## 5.2 Recommendations Regarding Application Areas

1) Police, Fire, and Medical Services , The introduction of a single capability such as automatic vehicle location (AVL) or computer-aided dispatching (CAD), by itself, is usually not sufficient to produce a significant improvement in police response times or apprehension rates. We feel that the emphasis in the future should be on an integrated system design, which attempts to reduce all of the major delay components associated with the dispatch operation and vehicle travel time. Without any increase in manpower, an average total response time in urban police emergency cases of less than three minutes appears to be feasible if the following advanced capabilities can be combined in a single system:

- a) Adoption of the 911 emergency telephone code.
- b) Automatic call distribution to assure that calls are handled on a first-come-first-served basis.
- c) Automatic telephone address lookup.
- d) Push-button dispatching made possible by the integration of CAD, AVL and digital data link functions, and the installation of mobile data terminals in the patrol vehicles.
- e) Adoption of dispatch strategies which will reduce queue and travel times for priority cases, e.g., preemption (if a patrol is busy on a non-priority case, allow it to be reassigned to an emergency, if necessary); greater use of one-man patrol cars; and dynamic deployment of free vehicles to cover sectors in which the sector car is busy.

The foregoing hypothesis suggests two important steps that should be taken under government sponsorship. First, experiments and field tests should be carried out immediately to establish the true value of reduced response time with respect to higher apprehension rates and improved service to the public. Second, a demonstration push-button dispatching system should be implemented as a test bed for the development of pertinent hardware and software, for the evaluation of system performance and benefits in a real-world urban environment, and for generating reliable

cost data.

The ability to quickly locate a patrol car in distress appears to be the determining factor in setting AVL accuracy requirements and we have concluded that a C.P.E. (95% confidence) of 400 feet would be adequate for this function (vehicle at rest). A system-wide position update interval of one minute seems to be a reasonable choice, if the small subset of candidate vehicles involved in a specific assignment can be polled no more than 10 seconds before the assignment is made. An average vehicle cruise speed of 15 mph is assumed.

From a functional viewpoint, future digitized police command and control systems naturally should be organized to best serve existing operating entities, i.e. individual police departments. However, this does not preclude the possibility of several adjacent towns or cities sharing a common CAD facility, as Montclair, Ontario, Upland, and Chino are doing in California, or of combining police, fire, and ambulance dispatching in a single system. The most efficient communications system organization from a technical viewpoint should consider the present and future needs of the entire metropolitan region, with integrated police, fire, civil defense, and emergency medical networks sharing a set of assigned channels and antenna sites. The Orange County Communications Division, which serves 23 separate police departments, the sheriff, 26 fire departments, 24 hospitals, and transit in an area of 784 square miles with a population of 1,700,000 people, is an good example of an integrated regional system. The advantages of a regional approach are more efficient use of the frequency spectrum and communications facilities, improved coordination of police, fire, and medical vehicles, the enhanced ability of neighboring cities and towns to assist each other, and reduced design and procurement costs. The inadvisability of piecemeal uncoordinated implementation, jurisdiction by jurisdiction, is apparent from a few examples. Boston with a population of 618,000 and an area of 46 square miles is the core city of a metropolitan region having a population of 2,900,000 and an area of 1017 square miles.\* It already has an operating CAD system based on voice communications. Each of the 79 cities and towns

---

\*Standard Metropolitan Statistical Area (SMSA) - 1970 census data

in the region could individually implement its own unique combination of CAD, AVL, and communications equipment, possibly with separate facilities for dispatching local fire trucks and emergency medical vehicles, or, if an appropriate system architecture were established at the start, the entire region could be served by a common data communications network and compatible CAD, AVL, and Mobile equipment which would allow the coordination of all mobile units and the real-time exchange of information between jurisdictions. Similarly, St. Louis with a population of only 558,000 is at the center of an SMSA with 2,371,000 people. All told, the 243 SMSA's defined in the 1970 census had a population of 139,419,000 people, 69% the U.S. total. Some SMSA's are so close together that they can be considered part of a single metropolitan region, and thirteen such groups, known as Standard Consolidated Statistical Areas (SCSA), had a population of 65,736,000 in 1970, 32% of the U.S. total\*. Made up of a complex crazy-quilt of jurisdictions spread out over a large area, these groups present the most difficult problems with respect to system integration. The Los Angeles SCSA encompassing the Los Angeles, Anaheim, Oxnard, and Riverside SMSA's (population 10,231,000 in 1974; area about 4500 square miles) illustrates some of the historical and institutional impediments to the adoption of an integrated regional command and control architecture. At the heart of the SCSA, the City of Los Angeles is in the process of acquiring a new \$30 M police communications network with CAD and mobile data terminals, the initial emphasis being on direct vehicle access to various central data bases. Simultaneously, a contiguous group of seven cities (Gardena, Hawthorne, Hermosa Beach, Manhattan Beach, Palos Verdes Estates, Redondo Beach, and El Segundo) has signed a contract for its own centralized

---

\*Boston-Lawrence-Lowell; Chicago-Gary; Cincinnati-Hamilton; Cleveland-Akron-Lorain; Detroit -Ann Harbor; Houston-Galveston; Los Angeles-Long Beach-Anaheim; Miami-Ft. Lauderdale; Milwaukee-Racine; New York-Newark-Jersey City; Philadelphia-Wilmington-Trenton; San Francisco-Oakland-San Jose; Seattle-Tacoma; 1970 Census Data

police and fire department CAD and communications system. The Fire Department in the City of Los Angeles has a communications setup, recently acquired at a cost of \$5M, which is separate from the police system. UMTA is about to initiate a large-scale transit control experiment in Los Angeles involving AVL and a digital communications network, with a potential future tie-in with the police system. Immediately to the East is Orange County whose Communications Division coordinates planning and operation for all public service radio facilities (police, sheriff, fire, transit, etc.) in the county and its 23 municipalities. About 400 FCC licenses are involved.

Another major obstacle to the integration of various urban command and control systems is that support is provided by a diverse group of local, state, and federal agencies, each addressing itself to a specific operational problem. On the federal level, for example, the Law Enforcement Assistance Administration (Justice) funds police systems; the Urban Mass Transit Administration (DOT) supports bus and paratransit systems; the National Highway Traffic Safety Administration (DOT) and the Department of Health, Education and Welfare provide money for emergency medical services; fire departments receive grants from HEW for combined EMS-fire dispatch facilities; the National Cargo Security Program, which combats truck hijacking, originates in the Department of Transportation; the Federal Aviation Administration (DOT) provides for aircraft navigation aids and communications; the Coast Guard (DOT) is responsible for aids to ship navigation such as Loran-C and emergency marine communications; and the Department of Defense supervises the organization and equipping of Civil Defense forces. We strongly recommend that an effort be made to coordinate these various programs and the policies of the Federal Communications Commission so that the design, implementation, and funding of integrated, multi-user regional systems can proceed. Intensive research is required to identify the optimum architecture and technical features of such systems, and we recommend that the Department of Transportation or the Department of Defense be designated as the lead agency with the responsibility of seeing that

a comprehensive investigation is carried out in a timely fashion.

With respect to the problem of coordinating multiple local jurisdictions, a few helpful precedents exist for encouraging cooperation. For example, the Office of Emergency Medical Services created by the Commonwealth of Massachusetts in 1973, "... may coordinate on a regional basis communications centers, ambulance services, hospital emergency services, law enforcement and fire units and emergency operations centers, and facilitate hospital transfers of patients." This office is also responsible for the development of a State Communications Plan which is in conformance with FCC regulations. Federal funds for the purchase of communications equipment cannot be allocated unless an approved Plan exists. "Desired systems features to be reviewed include voice and data transmission requirements, central dispatch/911, paging, telemetry, emergency backup and disaster requirements, tie-in to existing communications networks, and accessibility to the public and facilities to be served. In addition, an engineering and site selection survey will be conducted to determine the location and number of radio transmitter sites needed for 100% coverage in implementing voice communications for emergency medical purposes." A more adequate technological base for efficient regional systems integration must be developed, however, before such state and local efforts can hope to be fully successful. In this area, a federal initiative is essential.

2) Public Transportation. The key questions with respect to the application of AVL techniques to fixed-route busses are whether a significant improvement in headway dispersion can be achieved and to what degree this improvement can be converted into a worthwhile economic benefit. Pending the initiation of the large-scale, multi-user Los Angeles demonstration by UMTA, preliminary answers to these questions, we feel, can be obtained by a relatively simple set of simulated and real-life experiments on a typical high-density line such as the Harvard Square-Dudley route in Boston. In the proposed real-life tests, each bus assigned to the route selected would be equipped with an AVL device

and a digital data link enabling it to periodically transmit location data to a small central computer and, in return, to receive headway control information which would be displayed in an appropriate format to the driver. The latter requirement is critically important, since we are inclined to believe that the best headway performance will be achieved if each driver is given a continuous indication of how far ahead or behind the computer-generated schedule he is and is allowed to exercise his own judgement on the tactics required to best match the schedule. The schedule should be adaptive and not fixed, taking into account the current disposition of all the buses in the string. On a fixed route, the more general AVL capabilities (e.g. Loran C) are not needed and a less expensive device such as the odometer may be adequate if the driver can manually reset position at each end of the line and, perhaps, at one or two checkpoints along the route. A location C.P.E. (95% confidence) of 400 feet appears to be adequate with periodic updates every minute. Successive buses in the string, however, should be updated at approximately the same time. The proposed experiment would compare various centralized and distributed control tactics and evaluate scheduling algorithms, hardware performance, overall system benefits, and costs. The associated simulation study would explore a broader range of control options, including some, like the bus activation of traffic lights, that might not be feasible in the real-life testing. More precise control of headways should permit a reduction in layover times at both ends of every bus line and a significant increase in the utilization factor of a given bus fleet. Since this is potentially the most important AVL benefit that we have been able to identify in the area of bus transit systems, we recommend that the small-scale experiment described above be initiated as soon as possible.

There is a general feeling of pessimism among transportation experts regarding the ability of public transit systems to compete with the private car for a larger share of the urban trip-making market. The conventional wisdom is typified by the OTA study referred to on page 68, which concludes that the percentage of all urban passenger miles of travel

carried by public transit cannot be raised above 5% even by doubling the daily transit vehicle mileage and making the service free. The experts are even more dubious about the possibility of ever covering public transit operating costs out of the fare box (Reference 58). At the present time in Boston, for example, fares finance only 25% of the total cost of subway and bus service; in Milwaukee and Chicago the fares contribute about 65% of the operating costs. The average for 19 major transit systems is 43% (Boston Globe, September 21, 1977); the remainder coming from the local, state, or federal tax base as a subsidy.

Within the context of conventional public transit techniques, doubts about the ability to compete successfully with the private automobile seem to be well founded. Future plans for upgrading the nation's urban transit systems involve capital investments between 1972 and 1990 of up to \$58.2 billion (Reference 64), but most of this money will be spent conservatively on conventional transit improvements (extension of rail rapid transit lines, replacement and expansion of rail and bus fleets, upgrading maintenance facilities and stations, etc.). Innovative planning has not been encouraged by the financial and functional difficulties encountered by the few systems which have attempted to advance beyond traditional transit technology, e.g., the Bay Area Rapid Transit District (BARTD), the new Washington, D.C. subway, the personal rapid transit demonstration in Morgantown, W. Va., and numerous Dial-A-Ride experiments.

As indicated in Figure 20 (page 49), the critical problem in diverting trips from the private automobile to transit is to achieve a comparable door-to-door travel time. Whereas rail rapid transit can compete on favorable terms with a car, a bus system or an integrated bus-rail system, in general, cannot. The principal delays occur in the collection-distribution phases of a trip, phases traditionally handled by a network of fixed bus routes. On most urban bus lines, the frequency of service is low, so a large fraction of the desired trip time can be wasted on pickup delays or transfers from one line to another. For example, in Boston the MBTA only has 10 bus routes out of 187 with a scheduled headway of 6 minutes or less during the rush hours. On most

routes, serving inner suburbs with low or moderate demand, the rush-hour headway is in the range of 10 to 30 minutes. During the off-peak hours, of course, the scheduled interval between busses is substantially greater on all routes. A bus is subject to the same traffic delays as an auto, plus the time lost in picking up and dropping off passengers.

Another limitation of bus collector-distributor systems is the relatively short distance that customers are willing to walk. In the suburbs, the nearest bus line is often too far away. In Stockholm, the planning rule is that suburban apartments should be within about a quarter of a mile and single-family houses within about half-a-mile of a rapid transit station (Reference 65). By coordinating land use with the design of transportation facilities, the Swedish planners expect public transit to attract 90% (Central Business District) and 15% (outer suburbs) of home-work-home trips.

We believe that a paratransit mode could be developed that would compete successfully with the private automobile for about 30% of the trips in a metropolitan region such as Boston even with the existing distribution of land uses. This mode would integrate all of the following trip formats:

- a) Many-to-many (private) - taxi
- b) Many-to-many (shared) - Dial-A-Ride
- c) Many-to-one (shared) where the destination might be a school, a place of work, a shopping center, a rapid transit station or express bus stop, a special event, a child care center, a medical care center, a senior citizen center, an airport, etc.
- d) One-to-many (shared) - inverse of item 3
- e) Pickup and delivery of parcels, documents, mail, etc.
- f) Fixed-route bus service
- g) Rail rapid transit and commuter rail

The first five items should be organized town-by-town as a taxicab, not as a public transit, service with the driver's compensation being proportional to fares collected. Centralized dispatch, AVL, and communications facilities could be operated by a regional transit agency, but



competing entrepreneurs, ranging from individual owner-operators to fleet owners, would provide the actual transportation services. Customers would be able to select either the private or shared ride option, the former giving them faster delivery and the latter, lower cost. The control algorithm for the assignment of shared rides, however, should place an upper limit on the trip time imposed on any given passenger, and we anticipate that this restriction in the many-to-many mode will result in no more than two or three passengers being in the vehicle at a time. Profitability of the proposed paratransit system, therefore, will depend largely on how skillfully the many-to-one and one-to-many trip market is exploited, since an opportunity exists here to carry a larger number of passengers on each trip without unduly prolonging the trip time of any one passenger. The inclusion of pickup and delivery services provides a means of utilizing excess capacity during off-peak hours, further enhancing profitability.

The public transit part of the system would benefit from the paratransit adjunct in two ways. First of all, many of its fixed bus routes, which, for the most part, lose money, could be eliminated, resulting in a direct reduction of the operating deficit. Secondly, the faster, more convenient collection-distribution services provided by the paratransit mode would make the rail rapid transit or express bus segment of a multi-mode trip more attractive and should increase transit patronage. The public agencies could concentrate on improving the performance of the high-volume, trunkline services, the area in which they have a distinct competitive advantage over the private automobile. The introduction of personal rapid transit technology at some future date is expected to further enhance this advantage because of a reduction in the time spent waiting for a vehicle and the ability of a PRT vehicle to skip stops.

In view of the potential of an integrated paratransit-public transit system to divert trips from the private automobile, thereby reducing urban traffic congestion, lowering the level of air pollution, and conserving fuel, we recommend that an experimental paratransit test bed be established in an appropriate inner suburban community for the evaluation of equipment, operating methodologies, pricing strategies, benefits, and costs. The

experiment should avoid the gross errors committed in previous Dial-A-Ride demonstration; i.e.

- (1) It should be organized as a taxicab, not as a public transit, service with competing participants and the driver's compensation being proportional to fares collected.
- (2) It should offer a full spectrum of transportation services (private, shared ride, school bus, collection and delivery of workers to a specific site, package pickup and delivery, etc.) and it should have ready access to a rail rapid transit, commuter rail, or express bus terminal so that multi-mode trips can be evaluated. The various options could be introduced gradually, i.e., one at a time, if necessary. For example, regular taxicab service, employing AVL and CAD for nearest-car dispatching, might be tested first. This mode could then be extended to include a many-to-many, shared-ride option with lower fares. Finally, the participants could be allowed to exercise their entrepreneurial talents by offering cut-rate many-to-one or one-to-many customized services as dictated by the characteristics of the local trip-making market.
- (3) The area served should not be too large, as was the case in the Santa Clara County experiment, and a sufficient number of vehicles should be available to provide an overall trip time approaching that of a private car. (A condition which the Rochester experiment failed to meet).

The full-scale, real-life paratransit experiment suggested above should be preceded, of course, by a detailed analysis, simulation and design study, but such an undertaking was beyond the scope of the present contract.

3) Truck Dispatching and Security. The same mobile data link and AVL equipment developed for the police and paratransit applications can be used in the evaluation of truck applications. We recommend that a sizable fleet of pickup and delivery trucks (50-100) operated by a

single company in a metropolitan region such as Boston be enlisted for real-life experiments on truck dispatching, driver supervision, and countermeasures to hijacking. An approximate quantitative measure of the benefits achievable with AVL and CAD in truck dispatching can be obtained from simulation studies, but these results must ultimately be validated in the field. The truck dispatch algorithm is more complex than the simple "nearest-taxicab" case because each truck has a sequence of pickups and deliveries before returning to the freight terminal. A vehicle which is not closest to a given pickup point at the time the assignment is made may pass right by it at some time in the future. The fleet experiments should be used for the development of appropriate central office procedures and software, and for the evaluation of system performance, benefits, and costs in a real-world urban environment.

The fast pickup and delivery services (intra-city) which operate in many cities are obviously more closely related to the many-to-many mode of the paratransit system and should be tested as part of that experiment.

4) Disaster Relief and Civil Defense. There appears to be insufficient attention paid to the problem of keeping track of and coordinating the movement of all the vehicles that might be needed for disaster relief or civil defense operations in a given metropolitan region. In this category, obviously, are police cars, fire trucks, ambulances, power company trucks, gas company trucks, telephone company trucks, and military units (National Guard, Army, Air Force, Navy). In the event of a major disaster, however, the effective participation of many other vehicles, such as those operated by public works departments, transit companies, truck companies, and taxicab companies, could be of critical importance. We recommend that this problem be given careful consideration in the study of communications system architecture suggested earlier.

5) Aircraft Surface Navigation. As discussed in Section 2.5, the accuracy requirement for taxiway navigation and control under restricted visibility conditions is of the order of 20 feet (95%), more stringent than any of the other TRD applications investigated, and beyond the demonstrated capabilities of TRD technologies examined in this report. The Loran-C system, however, has come very close to this figure in measurements of the short-baseline St. Marys River mini-chain, which was installed with an accuracy goal of 25 feet (see Figure 26). Also, one-hour standard deviations of 8 meters (26.25 feet) have been achieved in the private North Sea "Pulse/8" chain with 250-mile baselines (References 47 and 48).

If Loran-C mini-chain technology develops for high-accuracy AVM and AVL applications in major urban areas, major airports would be included in the coverage areas, and the same chains might also be used for aircraft location on the airport surfaces, providing a larger application base for the installed systems. The converse of this would also be true, i.e., if Loran-C mini-chain technology were justified on the basis of the location of aircraft on airport surfaces for navigation and control purposes, the systems could also be used for other TRD applications in the same areas.

Investigation should be made of the use of Loran-C technology for aircraft navigation and collision avoidance on an airport surface under restricted visibility conditions. This application requires a multi-access digital data link which permits aircraft-to-aircraft and aircraft-to-tower-to-aircraft exchanges. Such a link could be developed based on the technology employed in the police and para-transit communication systems.

6) Other Aircraft and Marine Applications. The scope of this study included only TRD applications, i.e., location on the land surface. At least one of the TRD systems, Loran-C, would also provide location coverage for aircraft flying over-land, and for vessels on navigable inland waterways. No recommendation are given with respect to these applications, since they were not part of the study. Because of the possibilities for augmenting the utility of this particular

TRD system, however, some thoughts on the aircraft and inland waterway applications are presented in Appendix B. The formulation of a federal policy on the large-scale implementation of TRD techniques will, ultimately, be based on an evaluation of all the perceived costs and benefits. This evaluation will most certainly include potential marine and airborne, as well as terrestrial, applications.

### 5.3 Recommendations Regarding Technology Improvement

The location technology aspects of terrestrial radio determination (TRD) seem in general to be developing fairly well in response to the needs of the market-place, to the extent that four basic TRD technologies -- hyperbolic, multilateration, proximity, and dead-reckoning -- are now working well enough to be competitive for many applications. To be sure, the marketplace to this point has been almost entirely Federal Government related; either through the funding by one Federal agency or another of locally generated applications (e.g., St. Louis, Huntington Beach), or through Federally initiated demonstration projects (e.g., St. Mary's River and Los Angeles). Is further Federal initiative required in regard to TRD technology? Based on the results of this study, the authors feel that two areas of TRD technology should be so considered.

1) Loran-C. This TRD system is alone in providing accurate regional or country-wide coverage at reasonable cost, and the technology to reduce transmitter timing errors to negligible levels (e.g., 25 ns) is at hand. Hybridization with one or more of the other techniques can handle difficult receiving environments (e.g., high-rise urban areas), but Federally-initiated research directed at better understanding of the local anomaly problem would seem to be in order. Also, installation of the additional stations needed to complete coverage of the 48 states, with spacings appropriate for required TRD accuracy, would be necessary to permit Loran-C to serve those applications for which it is best suited.

2) TRD Communications. Communications has been pinpointed as a potential limiting technology in large-scale, multi-user TRD situations. Although no TRD system has yet been so limited (because so few vehicles were involved), it would appear advantageous for one or more Federal

agencies, including the FCC, to take the initiative in determining the most spectrally efficient way to handle large amounts of digital data in land-mobile radio communication, along the lines suggested in Section 4.5. This question seems too important to be left to the normal course of industry-FCC adversary proceedings, and should be a funded development.

## APPENDIX A

### visits and Other Contacts

During the course of the study ten organizations were visited. Of these, seven were law enforcement agencies, of which two have operational TRD systems (Huntington Beach, Calif., and St. Louis), one has had a pioneering TRD system that is no longer operational (Montclair, Calif.), one is considering a TRD system (Orange County, Calif.), and two are currently installing high-speed, mobile digital terminals (Los Angeles and Chicago). The Los Angeles terminal specification includes computer-aided dispatching (CAD) and provision for later addition of TRD, but TRD acquisition is not presently budgeted.

The Chicago Police Department is emphasizing mobile digital terminals (MDT's) to ease dispatcher work load on mobile inquiries to data banks. It has computer-aided dispatching next on its priority list but has little current interest in TRD. The seventh police department visited (Boston) has CAD, but no present plans for acquiring either TRD or mobile digital terminals (MDT's), although the CAD system is designed to work with both. Orange County and its 23 constituent municipal police departments, including Huntington Beach, have had 100-word per minute mobile printers for some time, and since Huntington Beach also had a CAD system prior to acquisition of its new TRD system, it alone in the U.S. has all the elements (MDT, CAD, TRD) that would be needed to implement pushbutton dispatching, as discussed in the body of the report. St. Louis has no immediate plans for either MDT's or CAD. Note however that the FLAIR system incorporates some mobile-to-base features of MDT's, since 10-codes may be transmitted by pushbuttons.

The status of the seven departments in regard to TRD, CAD, and MDT's may be summarized as follows (X = operational):

	<u>TRD</u>	<u>CAD</u>	<u>MDT's</u>
Huntington Beach	X	X	X
St. Louis	X		
Montclair	Did Have		
Boston		X	
Orange County	?		X
Los Angeles		Getting	Getting
Chicago		?	Getting

Visits were also made to Motorola to discuss digital mobile communication and TRD, to Megapulse/Internav to discuss Loran-C, and to the Boston Taxi Association to discuss possible taxi interest in TRD.

The information obtained in all these visits is included in various sections of this report as part of the technical discussions. The dates and people involved are summarized below.

#### 1. Chicago Police Department

On December 4, 1976, J.E. Ward met with Superintendent William Miller, Pat O'Shea (in charge of radios), and Mike Zazzaro to discuss the 32-character Motorola Mobile Digital Terminals being installed in 200 patrol cars. At the time of the visit, two MDT's were installed and the system was about to undergo acceptance testing prior to release of the remainder of the MDT's. Contractor tests up to that time had shown that the 900-MHz trunked radio system was providing excellent coverage, and that 99% of messages were repeat-free, compared to a 97% specification requirement.

Superintendent Miller demonstrated the new 911 incoming call system which directs calls to the appropriate dispatcher on the basis of call-origination area, and displays the calling number at the dispatcher location (name and address listing for the phone will be added shortly). One problem they have been having is that over the first four months of operation, a steady 40% of 911 callers hang up as soon as the dispatcher answers. No good explanation of this behavior has been found.



Superintendent Miller said that he was watching developments in TRD, but that it did not rank high on his list of priorities for new capabilities for the Department.

## 2. Motorola

Also on December 4, J.E. Ward met with Dr. Jona Cohn, Director of Research, Motorola, and several associates to discuss mobile digital communication and TRD. Certain details of the Motorola MDT transmission format were obtained, which are discussed in the body of the report. In regard to TRD, they said that they had looked at a great variety of approaches over the past few years, and that Loran-C currently seemed to offer the best combination of good coverage, reasonable accuracy, and high capacity.

## 3. Huntington Beach Police Department

J.E. Ward and M.E. Connelly met on December 13, 1976 with Sgt. Fickle to discuss the Hoffman "signpost" TRD system recently installed and its use in Department operations. Captain Michael Burkenfield was away at the time, but Officer Edward McLaughlin (AVM specialist) was able to join the conversations briefly. The TRD system was not in regular use at the time of the visit because of a number of minor hardware and software problems that were delaying final acceptance, but Sgt. Fickle was able to demonstrate the complete CAD, Address File, and TRD system. Much of the discussion concerned the CAD and Address File systems, with which the TRD system is integrated, and these aspects are covered in the main body of the report. The TRD system operates on a polling basis, sharing the city voice (Green) channel used for all dispatching. It is planned to poll patrol cars for location only when there is a dispatch to be made, both to keep TRD loading on the channel low, and to avoid possible "big brother" complaints that might be engendered if vehicle tracking was continuous. Other information from Hoffman indicates that because of the selective calling features in the Orange County Communications Net, of which

Huntington Beach is a part, each poll/response cycle takes about 200 milliseconds, thus at maximum, five vehicles can be polled per second.

#### 4. Orange County Communications Center

M.E. Connelly and J.E. Ward met with Mr. Donald Poorman, Manager of the Orange County Communications Division (OCCD) on December 13, after the morning visit to the Huntington Beach Police Department (3, above). The primary purpose was to discuss the June, 1976, five-volume Automatic Vehicle Location (AVL) study<sup>1</sup> for which Mr. Poorman was the technical manager. Mr. Poorman said that the study, prepared by Products of Information Systems, Costa Mesa, was then being reviewed by the 23 municipalities in the County and the County Sheriff's Office. It was his opinion that there would not prove to be much support for the county-wide, mixed triangulation/signpost system proposed in the study, and that there were more pressing needs for the estimated \$4.5 million needed to implement it. He cited an automatic document storage and retrieval system as of higher priority, in his opinion.

Possible undesirable aspects of AVL that he foresees are: the AVL information would not be available to the Field Sergeants, who actually run a police patrol operation; the location of motorcycles, helicopters, undercover cars, and foot patrolmen would not be known; that keeping AVL software up to date (blocked roads, etc.) would be a problem; and that the average policeman would resent the "big brother" aspects of AVL. He feels that 1/2-mile accuracy is sufficient for dispatching nearest vehicles, although several of the municipal police departments cited 1000 feet or less in their inputs to the study. Finally, he feels that the smaller cities don't need AVL, and that in the bigger cities it is too hard to implement. On the other hand if AVL is to go in and be cost effective, he feels that it should be implemented under the control and supervision of a regional organization such as the Orange County Communications Division.

Mr. Poorman spent some time describing the functions and operations of the OCCD, which is probably unique in the U.S. in providing a

coordinated communications system for all public communication services for a whole county, including:

- Marshal
- Police Departments (23)
- Sheriff
- Paramedic Teams and Hospitals (24)
- Fire Departments (26)
- Schools
- Airport-Maintenance and Security
- Air Defense
- Transit (fixed route and Dial-a-Ride)
- Animal Control
- Administrative Communications
- Environmental Management (Public Works)
- Parks and Recreation
- Sanitation \*

The OCCD is staffed by 96 people and it has an annual operating budget of over \$3 million. Orange County has a population of 1,700,000 spread out over 784 sq. miles. The Sheriff and police departments alone operated 694 vehicles in 1976, and this number is expected to increase to 1061 by 1986. At present, some 4129 miles of streets must be patrolled in the County. The OCCD law enforcement system consists of 13 two-way VHF channels (voice/MODAT), and two teleprinter channels, one assigned completely to Huntington Beach. Some channels are assigned county-wide; others are for local municipal use and assigned so that six channels serve 23 communities without mutual interference. To provide optimal signal coverage and quality, multiple remote repeater stations are strategically located throughout the County to relay mobile voice and digital radio frequency transmissions as desired. Several additional sites only have a microwave capability for linking stations; some can pick up RF signals and relay them via a microwave link to stations with an RF transmitter. A total of 13 repeater sites are involved in this relay net. The

Motorola telephone-line message switcher at OCCD central handles about 1,400,000 transactions per month, up to 50,000 on a busy day. A 4.8-megabyte disk provides 8-hour retrieval of data. A new 50-megabyte unit is scheduled to replace it. Magnetic tape is used to record all voice messages. Only one operator at OCCD central is used to compose teleprinter messages for the 500 mobile units, but messages can also be composed by individual police dispatchers. "Control One" located at OCCD monitors all county-wide channels, and can take over any channel for dispatch purposes when that is desirable.

The OCCD facility, housed in its own building, includes an electronic repair shop (OCCD performs all maintenance in-house), a garage for the installation and removal of mobile communications equipment, "Control One" consoles, a medinet console, Sheriff's dispatch console, message switcher, disk message storage, magnetic tape storage, hard copy printers, signal selection circuitry, transmitter-receiver bays, charging station for hand-held units, traffic light controllers, office space for professional staff, and backup power (5-second switch over). OCCD accumulates funds for the replacement of old equipment by "charging" users, like the Sheriff's Department, a depreciation fee every year. Two mobile emergency communications vans are equipped to operate on every channel and there is over \$100,000 worth of equipment in each. OCCD also operates 7 maintenance trucks. The Orange County Paramedic net, the best in the country according to Mr. Poorman, cost \$800,000 to implement. Instead of 24 monitors at 24 separate hospitals, only one monitor at OCCD central is required to operate the net.

By state law, 911 emergency dialing will be implemented in Orange County; it will be a sophisticated system with selective routing and automatic number identification. The goal will be to answer calls within 10 seconds and to dispatch a vehicle, if required, in less than one minute.

In spite of the 13-site relay net, there are radio reception dead spots all over the County and this sometimes causes garbled messages

on the mobile teleprinters. In general, the use of teleprinters and digital status signals (MODAT) varies greatly from one law enforcement department to another. Some use these capabilities extensively, some hardly at all.

##### 5. Montclair Police Department

One December 14, 1976, J.E. Ward and M.E. Connelly visited one of the genuine pioneers in AVL development, the Chief of Police of Montclair, California, Raymond McLean. Starting with a modest grant from the California Council on Criminal Justice in 1970 to study the applicability of AVL and status reporting systems to medium and small-size police departments, Chief McLean developed, implemented, and used in day-to-day operations a signpost-based system called LOCATES. The Montclair hardware went into service in November, 1972, hence it was the first operational AVL system employed for law enforcement, predating Huntington Beach by four years. The Montclair system is now shut down because a regional computer-aided dispatch facility is being acquired and the other communities in the network (Ontario, Upland, and Chino) do not have AVL capabilities. Loss of user confidence because of failures during the system shakedown phase and the inability to get additional operational support from outside agencies are also factors in the termination of the Montclair experiment.

Montclair has a population of about 27,000 and it covers an area of 5.2 square miles. Fifty location transmitters (signposts) using a 75-MHz transmission frequency were installed throughout the city with the spacing between units varying from 1/8 to 1/4 miles. Fifteen police vehicles were equipped with special electronics to pick up 16-bit signposts within a range of 600' and transmit digital location and status information to the police command center via a secondary voice channel. Vehicles are not regularly polled and the transmission of digital location data normally occurs only when the vehicle first enters the coverage area of a new signpost, about every 15-30 seconds at normal patrol speeds. At the center, car locations and status were displayed automatically on a large-scale

map to assist the dispatcher in the assignment of units. The dispatcher was able to transmit a limited number of fixed digital messages to any selected mobile unit. An emergency signalling device was also developed that could be worn by an Officer, away from his vehicle, and used to alert the Command Center via the vehicle radio that assistance was required; but this was never put into use.

The Montclair hardware was developed by a division of Products of Information Systems called Applied Technology. During Phase 1 of the project in 1970-71, Montclair surveyed 220 potential vendors prior to selecting equipment for installation. Four of the firms contacted (Applied Technology, Astrophysics Research, Cubic, and Magnavox) actually demonstrated their AVL systems in the Montclair environment. These companies proposed proximity, Decca, Triangulation, and Omega techniques respectively. The proximity approach was selected on the basis of cost, utility, reliability, and the ability to expand modularly without interfering with other jurisdictions. Position accuracy and update rate could be improved by reduced signpost spacing; but in retrospect, Chief McLean felt that even 1/2 mile spacing might have been adequate for vehicle assignment purposes.

The numerous practical difficulties encountered with the system during the debugging phase are fully described in the Phase 2 Final Report, March 1974 (Reference 10). Apparently failures, faulty messages and locations, and interference with normal police operations during this period caused many of the users to lose confidence in the system. Ultimately, reliable operation was achieved according to Chief McLean, but by that time opinions within the force were divided between those who liked the system and those who did not. Officer safety should be stressed in indoctrinating personnel and AVL should not be employed to detect breaches in discipline. As a small city, Montclair lacked the influence of Los Angeles or even Huntington Beach, consequently funds that could have been used to support continued improvements in the system were diverted elsewhere.

The 18-month evaluation of the LOCATES system showed definite improvements in dispatch performance. For example, with the system, 86% of the critical dispatches took less than one minute to complete, whereas without the system, only 64% of the critical dispatches were completed in less than one minute. When using LOCATES, 78% of critical events had a total response time of less than 4 minutes, while without it, only 58% of the critical events had such a response.

The benefits of relieving the voice channel congestion by using the digital status message capability that was part of LOCATES was not quantified in the Montclair Phase II Final Report (Reference 10). The transmission of a status message, such as acknowledge, requires about 3.6 seconds by voice, whereas a LOCATES Transmission takes 0.9 seconds, a 75% reduction in channel occupancy. However, digital status messages were often followed up by a verbal verification, defeating the purpose of the digital transmission. With respect to message integrity, approximately 4.2% of the digital messages received during the evaluation period were false, i.e., contained errors.

#### 6. Los Angeles Police Department

On December 14, 1976, J.E. Ward and M.E. Connelly visited with Captain G.E. Conroy of the Los Angeles Police Department, who is in charge of procurement of their "PROJECT X" system (Emergency Command Communications Control System --- ECCCS). The total eventual cost of the system, which includes mobile digital terminals and automatic address verification, is expected to be \$25-30 million. Although AVL will not be included in the initial installation, the Phase I system specifications (July, 1976) require provisions for the later addition of a 64-bit AVL message capability. The contract for the first of four phases was expected to be awarded early in 1977. Motorola and System Development Corporation were the only bidders, the latter proposing PDP-11/70 computers and E-System terminals. About 800 cars out of 1500 will be equipped with terminals. With 500 vehicles on patrol simultaneously in Los Angeles, congestion

on the present five VHF radio channels is severe (annually there are 1.5 million license plate inquiries, 750,000 drivers license inquiries, etc.) The present voice (VHF) channels will be converted to digital mobile terminal use, and voice will be shifted to new UHF channels. LAPD employs mostly two-man vehicles. Three to five teams cover an area under the direction of a Lieutenant. In a high-priority situation, a car might cross over into another area. This mode of operation will create problems when the AVL system tries to assign the nearest car regardless of its assigned area. Captain Conroy is also concerned about the loss of a voice party line when communications become digital.

The AVL accuracy goal of the LAPD is 100', based on officer safety, e.g. finding an unconscious officer in an alley or locating a motorcycle involved in an accident. However, less stringent thresholds of 300' and 500' are also given, with 500' the maximum acceptable.

The number of daily dispatches for the LAPD varied from a low of 2481 to a high of 6468 over a 28-day period. A vehicle dispatch occurs for about 40% of the phone calls handled. In addition, there are approximately 7700 officer-initiated calls. The silent alarm system (business buildings) produces too many false alarms to allow it to communicate directly with the cars. The 911 emergency dialing has not yet been implemented in Los Angeles, but is expected to be in operation by 1981. Captain Conroy is in charge of this program also.

The LAPD is divided into four operating Bureaus; the Central Bureau will be the first to utilize the new MDT equipment. The San Fernando Valley Bureau will, hopefully, be equipped by July, 1979. These schedules are predicated on City Council approval of the necessary funding. (L.A. voters approved the necessary tax package in May, 1977).

The emphasis in Phase 1 will be to provide direct access from mobile digital terminals to various central data bases, i.e. Los Angeles Data Service Bureau, CJIS, Department of Motor Vehicles, and the NCIC. In addition, each MDT will be able to transmit fixed-text messages by the activation of a single pushbutton. Each terminal will



be capable of communicating with any other terminal via the base station. Supervisory vehicles will be equipped with hard copy printers, and patrol vehicles will be equipped with cassette recorders for message retention.

#### 7. Boston Police Department

John Ward, Avram Tetewsky, and Mark Connelly of M.I.T.-E.S.L. and Harold Stein of D.O.T.-T.S.C. visited the Boston Police Department Headquarters on January 5, 1977, to see the BPD computer-aided dispatch system in operation and to assess the potential applicability of terrestrial radio determination techniques. Officer Albert Knuipis was our official host and he gave us a tour through the BPD Command and Control Center, assisted by Sergeant McGee, the watch chief. We also met briefly with Joseph Sarno, the Director of Data Processing and visited the BPD's inhouse television studio. We did not have an opportunity to meet the Communications Director, Lt. Det. Geagan.

The CAD system was designed, programmed, and debugged by Arthur D. Little, Inc. and has been in operation for almost two years. It was set up to accommodate mobile digital terminals at some future date if the BPD decides to invest in such equipment. MDT's would be introduced in three phases; experimental trial, installation in district headquarters, and, finally, installation in the patrol vehicles. Boston is not currently contemplating AVL or MDT's, but the CAD system was designed with these in mind. Sgt. McGee estimates that the CAD system has reduced response time by roughly 1 minute. The average overall response time on priority calls in December, 1976, was 7 minutes; 2 minutes received-to-dispatch and 5 minutes dispatch-to-arrive. After arrival, priority events require, on the average, 20 minutes to clear. At this level, a one-minute reduction would have very little effect on the rate of apprehension. Quick response, however, greatly influences the public's opinion of the quality of police service it is getting, and can often prevent a non-criminal event like a family argument from escalating into a criminal event (assault). The CAD system also provides benefits with

respect to direct recording of complaint data, supplying district headquarters with current command and control information, processing statistical information used in the management of operations and resource allocation, and the storing and updating of criminal information.

All emergency calls (police, fire, ambulance, etc.) are received at one of 15 CRT display/keyboard positions where a complaint clerk types in the details of the complaint (five of these stations are dedicated to calls on stolen vehicles). The typed information is displayed on the CRT and visually verified by the clerk. Errors are corrected, if found, and the information is entered into the computer by pushing a button. The computer automatically executes an address verification routine, which confirms the validity of the incident location and notifies the clerk so that he can request a clarification from the caller, if necessary, prior to leaving the call. The complaint message is automatically placed in the queue of the appropriate dispatcher and after all higher priority messages have been cleared, it appears on the dispatcher's display. In assigning a vehicle to the incident, the dispatcher is aided by a vehicle status display, which must be kept up-to-date by manual computer entries since the BPD vehicles do not have AVL or digital status terminals. The computer, however, specifies the sector corresponding to the address of the incident and, normally, if the patrol in that sector is available, it will be dispatched to the scene. If the sector is busy, the dispatcher must select a patrol from one of the adjacent sectors. An analysis of dispatch operations has shown that over 70% of a vehicle's assignments are to incidents outside of its own sector (Reference 8).

The city is divided into five communication zones, each of which has a separate duplex UHF channel for patrol cars communications and a separate dispatcher. A sixth channel (#1) is provided for inquiries from the field and city-wide operations such as a civil disturbance. The walkie-talkies in a given zone operate on the same channel as the cars. Additional channels are available for towing (#7), hospitals, schools,

auxiliary police, surveillance, and administration. One VHF channel is used for inter-city police operations. An average of 3500 calls are received each day for police service, of which only about 200 relate to criminal activity. On some weekend nights, it is not uncommon for the Department to receive 7000 calls.

Since 1973, the total number of police vehicles has increased from 179 to 273, but only 100 to 225 of these would be on patrol at one time. The normal BPD complement of 2700 officers is now 500 under strength because of budgetary restrictions. The leadership sees prompt and effective responses to 911 (emergency) calls as the Department's primary function. The city is divided into six commands, each under a Deputy Superintendent, and these, in turn, are sub-divided into a total of 11 districts. The districts are further divided into patrol sectors, which range in size from 0.1 to 1.0 square miles. The total area of the City of Boston is 45 sq. miles. A seventh radio channel used by the Traffic Division has provisions for car-to-car communications. All cars can transmit and receive on Channel #1.

#### 8. St. Louis Police Department/Boeing

J.E. Ward, M.E. Connelly, and A. Tetewsky visited the St. Louis Police Department on February 1, 1977 and met with Herb Boesch, Director of Communications, SLPD, and Robert A. McMillen, Manager of AVM Research and Development, The Boeing Company. This visit had been originally arranged for mid-January, but was postponed at Boeing's suggestion because of the scheduled cut-over of three districts to operational FLAIR status on January 31 and the opportunity to see the system in actual use. (The previous Phase I tests in District 3 were considered limited in scope because cross-assignments were not possible.) Three more districts were scheduled to cut-over on February 14, and the remaining three on February 28, thus FLAIR should be operating city-wide after March 1. Herb Boesch said that within 20 minutes of the operational startup on January 31, a nearest-car designated by the FLAIR system happened to be a patrol returning to the station house at the end of its tour of duty, and was only two blocks from the incident at the time of the call. An arrest was made.

All aspects of the dispatcher's display were demonstrated on a scope monitoring the system operation. The high-speed updating (every 1.25 seconds) of 200 vehicles positions provides a very effective view of the patrol situation -- cars move along the streets of the computer-generated map in a most realistic manner. By comparison, the Huntington Beach (Hoffman Electronics) AVM system can update 50 vehicles positions at 11-second intervals, and then only if there is no voice traffic on the shared voice/digital channel. During the hour or so spent in observing the console, there were always at least two or three vehicles in "V" status, indicating that they needed to be initialized by the dispatchers. This is apparently not a major operational draw-back, but some scheme for automatic initialization, perhaps based on signposts, would appear to be a valuable addition. This is, of course, recognized by both the Department and Boeing, but there is no funding for it in the offing.

The \$1,800,000 contract for FLAIR covered installations in 200 vehicles: 149 assigned to districts and the rest mobile reserve and garage extras. A figure of \$4,200 was given as the per-vehicle hardware cost, including radios, or \$840,000 for 200 vehicles. The remainder of the contract (\$960,000) covered base equipment, programming, engineering, and other costs. A substantial effort is involved in coding every street, alley, and off-street location that a patrol vehicle can drive in as a vector for the computer map of the city. Aerial photos are used to supplement city maps which may not be up to date and/or contain survey errors.

One difference between St. Louis and Huntington Beach (Hoffman Electronics) is that the St. Louis System does not display incidents, only the manually positioned cursor. This is because St. Louis does not have a CAD system, and incidents are still kept track of by slips of paper.

The FLAIR system operates at considerably higher bit rates (4800 bps) in the land-mobile radio channel than any of the other AVM systems, and uses no error detection or correction coding. This,

combined with the short message lengths (16 bits) permitted by incremental updating, provides an update rate of 177 vehicles per second. Mr. McMillen said that each bit is tested for r-f signal level and accepted only if it is above threshold. Any message with one or more rejected bits is ignored, i.e., no update is made. This is not a problem for isolated missed messages, but a number of sequential missed messages may require the vehicle to be initialized.

Police operations aspects of the St. Louis FLAIR system are being described in the body of the report.

#### 9. City of Boston Cab Association

M.E. Connelly and J.E. Ward visited Ted Kline in Boston on March 4, 1977, to discuss possible uses of AVL in taxicab operations. Mr. Kline is the publisher of the Taxi News Digest, and also secretary of the City of Boston Cab Association, which has nine member companies operating 350 of the City's 1535 cabs. Mr. Kline feels that AVL could reduce the average 100 miles per cab-shift by 10%, with estimated savings of almost \$800 per year per cab. He also feels that AVL is vital for safety reasons, citing the average 700-800 cab robberies per year in Boston, and the number of drivers badly injured in robberies. Other information obtained is discussed in Section 2.2 of the main body of the report (pp. 40-47).

#### 10. Megapulse Inc./International Navigation Corporation

On April 8, 1977, J.E. Ward, M.E. Connelly and A. Tetewsky visited Megapulse Inc., Bedford, Massachusetts, a maker of solid-state Loran-C transmitters, and met with Dr. Paul Johannessen, President, Mike Fitzmorris, Ed. McGann, and Frank Cassidy. Also attending the meeting were Robert Goddard and John Currie from Internav, an associated company making Loran-C receivers. The purpose of the meeting was to discuss the state-of-the-art in Loran-C, and possible developments in the future.

The Megapulse representatives described the North Sea "Pulse/8" chain that they have installed for oil drilling operations, and which is providing accuracy of about 35 meters without static correction, and

standard deviations over one-hour periods of less than eight meters (Refs. 47 and 48). This privately operated system uses 1-kw transmitters on 250-mile baselines. They also discussed the St. Mary's River installation for the U.S. Coast Guard which is designed to provide 25-foot accuracy for ship navigation, and which was officially tested in June.

Megapulse makes a modular line of Loran-C transmitters from 100 watts up to 2 megawatts. The larger sizes have considerable redundancy from paralleled units, and elements can be removed for repair or maintenance without shutting down. Up-time experience is 99.5% or better. Many of these elements and systems were seen on a plant tour, including the large transmitter being assembled for the new Seneca, N.Y. master station of the reconfigured East Coast Chain. (Scheduled to be operational July 1978).

Tests of the new West Coast Chain are indicating some difficulties with signal strength in certain critical areas. The Megapulse people feel that some of the baselines are too long, and that the geometry is not ideal for coastal coverage. They also feel that internal land coverage of the U.S. should be based on siting stations 300-500 miles apart, closer than the present planning for possible future Loran-C extension that contemplates only three stations to cover the far West area between the Great Lakes (operational 2/'80) and West Coast chains.

In the receiver area, Internav feels that \$500 receivers are achievable if sufficient volume develops. Commercial units are presently in the \$3,000-3,500 price range, although one recent volume purchase of 230 units by the U.S. Coast Guard was at under \$1,000 each. In the marine and aviation markets, the potential sales are in the area of one million and 200,000, respectively.

In answer to a query about the possibility of M.I.T.'s borrowing a Loran-C receiver for mobile tests in Boston it was indicated that this could probably be done. Bob Goddard (who had left the meeting before this question came up) was designated as the contact point. (An Internav 204 receiver was later borrowed for use by Constantine Photopoulos

in a Bachelor of Science thesis conducted under the project and supervised by M.E. Connelly.) (Reference 49).

11. Other Visits in the Boston Area

In March, 1977, A.K. Tetewsky and M.E. Connelly visited the Massachusetts Office of Emergency Medical Services to talk to Mr. Culp about the applicability of AVL to ambulance services.

M.E. Connelly also reviewed Coast Guard operations with personnel at the First District headquarters, and bus services in the Metropolitan Boston area with the central dispatching staff of the Massachusetts Bay Transportation Authority. A follow-up discussion was held with Mr. Ralph Dandrea at the MBTA Engineering Department concerning his cost-benefit study of a proposed bus communications system.

In August, 1977, M.E. Connelly visited Mr. Leslie Morash, President of the B.N. Corkum Transportation Company, Wilmington, to obtain information on truck hijacking in New England and on the applicability of AVL techniques to pickup and delivery services. Mr. Morash is also the President of the Transportation Security Council of Massachusetts. A subsequent visit was made to Mr. Morris, who supervises hijacking investigations at the Boston F.B.I. office, to discuss federal statistics on hijacking losses.

## APPENDIX B

### Comments on Non-Terrestrial Applications that might Share TRD Location Capabilities and Technology

The present study was limited to terrestrial uses of various location techniques, primarily for automatic vehicle location (AVL) and automatic vehicle monitoring (AVM) of wheeled vehicles. Some of the TRD techniques are, of course, not restricted to location on the land surface, and can provide location for aircraft and watercraft within their coverage areas. If governmental consideration is to be given to installing a nationwide TRD capability, it would appear that the aircraft and inland-marine location needs should be included in any analysis of total system costs and benefits. With this in mind, a brief discussion of potential aviation and marine applications is appended below, even though such uses, strictly speaking, are outside the scope of the study.

#### 1. Air Navigation

A critical requirement for greater capacity at the major air terminals and for safe, efficient, segregated airspace structures has created the need for a more precise aircraft navigation aid than VOR-DME. In addition, the advent of Category 3 landings and takeoffs, requires, as a prerequisite, a method of navigating aircraft and avoiding conflicts on the airport surface under Category 3 visibility conditions. We believe that at least one of the TRD techniques discussed in this report, Loran-C, could satisfy the future terminal, en route, and surface navigation requirements of aircraft and that future studies will find it profitable to include these applications in the evaluation of the costs and benefits of providing nationwide TRD coverage.

The standard method of navigating aircraft in the United States is to utilize bearing and range with respect to VOR-DME or VORTAC ground stations. There are about 700 of these sites scattered throughout



the CONUS in addition to 200 VOR-only sites. In general, the FAA route structure is composed of piecewise-linear segments connecting a sequence of VORTAC stations, although arbitrary fixes defining a route are often designated by range and/or bearing relative to one or more stations. VOR (bearing) operates in the VHF range (108.2 - 117.9 MHz), and DME (range) operates in the UHF range (962 - 1215 MHz). Both devices, therefore, are limited by line-of-sight propagation, hence a large number of ground stations are necessary to provide coverage for aircraft flying at the lower altitudes. Since position is usually obtained in terms of range and bearing with respect to a given VORTAC site, position accuracy degrades with increasing range. With a typical VORTAC bearing error of  $\pm 3.55^\circ$  (95% probability) and a range error of  $\pm .5$  nm. or 3% of slant range, whichever is greater, the airspace corridor reserved for a given route must be at least  $\pm 3.5$  nm. wide 50 nm. from the station because of the uncertainty in the position of aircraft at that range. This does not include any allowance for flight technical errors, i.e., pilot errors (Reference 34), but it does incorporate airborne receiver as well as VORTAC errors. Propagation anomalies and dead spots are common in mountainous regions or areas where multi-path effects occur. The relatively poor accuracy of VORTAC fixes at a distance from the stations makes it difficult to lay out safe, efficient route structures, especially in the major terminal areas where arriving and departing carrier traffic is mixed with traffic from satellite airports and local, short-haul aircraft. Closely-spaced, segregated routes are desirable to provide first-order conflict protection for all these classes of aircraft. VORTAC-defined routes are also limited by the finite number of VORTAC stations available in each metropolitan area and by restrictions on the placement of these stations. Moreover, in the present system, traffic naturally funnels over the VORTAC sites, greatly increasing the probability of conflicts and introducing intrinsic bottlenecks which reduce capacity. VORTAC-to-VORTAC routing, of course, requires more flight miles than direct routing.

The arguments for an airborne area navigation capability are well-known. It is widely recognized that first-order conflict protection in dense traffic areas ideally should be achieved by the use of orderly flows in segregated airspace structures. However, to provide non-conflicting routing for arrivals and departures and to service traffic efficiently at all compass points, a rather complex 3D airspace structure is required. Area navigation provides the pilot with an independent means of following such a structure accurately at an acceptable workload level, and a flexible choice of efficient route layouts is made possible because tracks are not restricted to VOR radials and are not constrained by VOR site limitations. The use of parallel tracks and elimination of the funneling of traffic over VOR stations would, in themselves, be major safety improvements and would increase capacity and reduce controller workloads.

In the busy terminals today, however, the derandomization or organization of flow is carried out by radar vectoring. This method, based on extemporaneous path stretching and speed control under the direction of a ATC controller, requires a great amount of airspace. The capability for the pilot to follow 3D structures accurately is of little consequence, since the controller, in effect, navigates the aircraft from the ground.

Runway capacity is determined primarily by the precision with which aircraft are delivered at the runway threshold and by runway occupancy time. The latter can be reduced to a degree by using high-speed exits and by indoctrinating pilots with the importance of getting off the active runway as soon as possible after a landing. Precise delivery at the runway threshold, on the other hand, has only been demonstrated experimentally to date using area navigation in four dimensions (4D RNAV), i.e., the technique of getting an aircraft to a specific point in the airspace at a scheduled time employing closed-loop speed control. Simulation studies at M.I.T. (Reference 37), NASA-Langley (38), NASA-Ames (Reference 39), and Boeing (Reference 40) have independently established that the dispersion of the error in arrival time at the runway threshold can be reduced to 5 seconds or less in a 4D RNAV approach.

Segregated, efficient 3D terminal structures and precise 4D RNAV delivery of aircraft at the runway threshold require a more accurate method of determining aircraft positions than VOR-DME. On final approach, a typical carrier jet will fly in the speed range of 130-150 knots (220-253 ft. per second). If an aircraft is scheduled to arrive at the runway at a specific time and the allowable error in arrival time must have a standard deviation of about 5 seconds, then the navigation error must be small (20%, say) relative to the distance traveled by the aircraft in 5 seconds. If the navigation error has a normal distribution along two orthogonal axes, each with a standard deviation  $\sigma_N$ , we can set an acceptable limit of 220 feet on the value of  $\sigma_N$ . This is equivalent to a C.P.E. (95% probability) of 540 feet for the navigation error. Such accuracy is well within the capabilities of LORAN-C.

En route, with a comprehensive RNAV structure of direct routes, significant reduction in flight distances are possible and high-capacity parallel tracks would enable aircraft to avoid delays and to utilize their optimum flight profile.

If the next generation ATC system will require much greater precision in navigation to assure safe, efficient operations, a question to be answered is whether this requirement should be met by a gradual transition to LORAN-C, or by refinement of the present VOR-DME network. If LORAN-C can meet future needs, it could do so at a much lower overall cost. In any changeover, parallel operation of both systems would probably be necessary until about 1995 because of the current large investment in VOR/DME avionics and ground facilities. The National Plan for Navigation (Reference 77) estimates this investment as \$1.3 billion for the civilian system alone.

Suitable Loran-C equipment for air transport and general aviation use is not currently available, although the military forces have airborne Loran-D equipment, and used it extensively in Southeast Asia for tactical purposes. A program to develop and flight test Loran-C equipment for civilian airborne use should be initiated, with emphasis on providing an appropriate cockpit display for following a 2D route structure defined in terms of a universal coordinate system such as

latitude-longitude instead of time differences, faster Loran-C signal acquisition and tracking capabilities, and a convenient means for a pilot to select the optimum master-slave station pairs as a flight progresses and to set up waypoints marking the desired route. The only gap in presently scheduled Loran-C coverage over the continental U.S. by 1980 will be the Rocky Mountain region, and this could be filled by installing three to five additional Loran-C stations. Combining air and TRD applications could provide a stronger justification for closing this coverage gap.

## 2. Inland Waterway Uses

Precise knowledge of a vessel's position is an obvious prerequisite for safe and expeditious navigation, particularly in the major ports and on heavily used waterways. Since both commercial shipping and recreational boating is concentrated, for the most part, near centers of population, there is a possibility of utilizing metropolitan TRD systems to provide useful services to waterborne vehicles in their vicinity. A more likely approach would be to adapt TRD technology to the special needs of vessels, i.e., implement a system dedicated solely to marine uses. The potential applications would be:

- (1) Navigation: avoidance of hazards and conformance to channels, adherence to instructions issued by a harbor traffic control system
- (2) Collision Avoidance
- (3) Assist the Coast Guard in search and rescue operations by providing an exact location of vessels in distress
- (4) Assist the Coast Guard in the upkeep of aids to navigation, particularly buoys
- (5) Continuous monitoring of vessels with a hazardous cargo
- (6) Law Enforcement: Pollution Control, detection of smugglers and infractions of fishing regulations.

Boats within an area of TRD coverage could derive their position from the system and could receive and transmit information via the TRD digital data

link. With a long-range location system such as Loran C, continuous position information could be available to boats on all inland waterways of importance, just as it will be by 1980 for the coastal confluence zone.

The accuracy requirements for safe navigation vary greatly with the circumstances. Most marine navigation consists of short, linear segments from one navigation aid to another. Often, the helmsman simply dead reckons along a course leading to the next buoy or light-house in sequence until that navigation aid can be located by radar, sight, or sound. In general, errors on the present leg can be corrected after the aid is detected and do not carry over into the next leg of the course. Point-to-point navigation can be successfully carried out with minimal equipment on board each vessel; the main burden falls on the Coast Guard which must continuously check thousands of fixed aids to assure that they are correctly placed and in good working order. Buoys are frequently displaced by storms, lights fail, and horns malfunction, so the crew on each vessel must always be on the alert for such anomalies which can be hazardous. With complex, narrow passageways, a large number of navigation aids are required to define the channel precisely.

In dense traffic areas, collision with other vessels is a hazard equal in importance to accidental grounding, and buoy-to-buoy navigation is of limited usefulness in preventing collisions. Surprisingly, ship-board radar also fails to protect vessels from collisions on many occasions. Conflict between radar-equipped ships occurs so frequently that a special phrase has been coined to describe the phenomenon, i.e., "radar assisted collisions". Typically in such cases, each helmsman sees the other vessel on his radar display and executes an evasive maneuver. Since the maneuvers are uncoordinated and it takes a finite amount of time to detect what the other boat has done, they inadvertently end up on a collision course in which contact is unavoidable given the sluggish response of large vessels. Whereas off-shore navigation standards

tend to be relatively casual\*, the need to adhere to complex, narrow channels and to avoid collisions imposes much more severe requirements on vessels which utilize inland waterways and the busy harbors.

It appears that the basic functions of TRD system, precise determination of position and the exchange of information via a digital data link, could be readily adopted to the general problem of vessel navigation and collision avoidance. Successful collision avoidance requires not only that the relative position of nearby vessels be known, but also their intent, i.e., their projected trajectory over the next few minutes. By periodically exchanging position, heading, speed, and rate of turn data with each other via data link, vessels can be provided with the necessary information (properly displayed) to maintain safe separations at all times. When a vessel is operating in an area covered by one of the coast Guard's Vessel Traffic Systems (VTS), that system could derive backup surveillance data by eavesdropping on the transmissions and could also utilize the data link for issuing control commands and advisories on special hazards. At present, V.T.S. installations have been made in Puget Sound, the Houston Ship Channel, and San Francisco, with additional installations planned for New York, New Orleans, and Prince William Sound on the approach to Valdez. These are primarily oriented to ocean-based ship traffic, but several of these sites also are terminals for major inland waterways.

The worst-case accuracy requirement for vessel navigation and collision avoidance on inland waterways is probably of the order of 25 to 50 feet, considerably more stringent than for most TRD applications, but comparable to the requirements for aircraft guidance on an airport surface. A recent experiment with the short-baseline LORAN-C chain near Sault Ste. Marie indicates that such accuracies can be achieved in selected areas. (Reference 55).

---

\*The Argo Merchant was 20 n.miles off course when it grounded southeast of Nantucket spilling 7.5 million gallons of oil into the Atlantic.

Similar mini-chains would be economically feasible in metropolitan areas like New York to simultaneously serve the very precise location requirements of ships and aircraft, and local TRD users such as police, transit, trucks, and taxis. Twenty-two of the twenty-five busiest air carrier airports in the United States are located near large cities that are also shipping centers, so there is a fortuitous match between potential TRD applications and the navigation needs of air and water transport modes.

A major problem in search and rescue missions both on inland waterways and off coasts, is to accurately locate vessels in distress so that the appropriate resources can be promptly dispatched to the area. TRD techniques would be extremely helpful in that an endangered ship's current position in a common coordinate system could be transmitted either via voice or data link. If only the larger recreational vessels and most commercial vessels were equipped with TRD equipment, these boats could report accidents involving vessels in their vicinity which do not carry such equipment. The net result could be a significant improvement in the effectiveness of search and rescue operations, although it is difficult to attach a firm quantitative value to this benefit.

Another possible TRD application is to assist in the task of maintaining tens of thousands of navigation aids on inland and coastal waters. A TRD system, if it had the requisite accuracy, could provide a quick, convenient method of checking the location of buoys and of relocating them properly if they have drifted. In time, as more and more vessels are equipped with accurate electronic navigation devices, it may be possible to reduce the total number of floating and land-based aids that must be maintained. The upkeep of navigation aids is a major Coast Guard activity and any improvement in efficiency would lead to a significant budgetary benefit.

In most TRD applications, communication is between a vehicle and a central facility. Because the movement of ships on inland and coastal waterways is dispersed over a wide area, a data link utilized

for collision avoidance in maritime operations should permit vessels to exchange position, speed, heading, and rate of turn information directly with each other, independent of any shore-based facility. The latter, of course, can be involved in the interchange of data also, as would be required by harbor traffic control systems, search and rescue missions, and vessel monitoring.

A multi-access digital data link developed for ship-to-ship and ship-to-shore-to-ship exchanges could employ the same technology as the police, ambulance, paratransit, and aircraft data links previously discussed.

Loran-C equipment, if used for inland marine applications in addition to its present standardization for the Coastal Confluence Zone, should include the automatic conversion from time differences to latitude-longitude coordinates to avoid time delays and possible errors in manually converting time difference readouts to lines-of-position on a chart in order to determine a vessel's location. A continuous heading-up indication of a vessel's position relative to nearby ships and to the course being followed would be desirable. The projected future trajectory of each ship displayed would also be a valuable aid in preventing collisions, a feature that could be made possible by the periodic exchange of data between vessels via data link. Prior simulation studies should be carried out with realistic ship dynamics and disturbances to validate the functional effectiveness of this concept, to determine accuracy and update rate requirements, and to optimize the human factors aspects of the display design.



APPENDIX C

References

1. Automatic Vehicle Locator System Study (5 vol.'s), Prepared for the Orange County General Services Agency by Products of Information Systems, June, 1976.
2. Radio Navigation Study (2 vol.'s), prepared for the Office of Telecommunications Policy by G. Frenkel et al of the Computer Sciences Corp., February, 1975, AD-A010 114/115.
3. Terrestrial Radiodetermination Potential Users and Their Requirements, Cantor, Farr, and Kodis, D.O.T. Transportation Systems Center, July, 1976, DOT-TSC-OST-76-7.
4. Loran-C Conceptual Analysis prepared for the National Highway Traffic Safety Administration by the New York State Department of Motor Vehicles and Polhemus Navigation Sciences, June, 1976.
5. Public Urban Locator Service (PULSE) - Background and Conference Proceedings, edited for the Department of Housing and Urban Development by the Institute of Public Administration and Tekekron, PB 180 116, October, 1968.
6. Overview of Automatic Vehicle Monitoring Systems, Murray and Scales, MITRE Corp., PB 223 509, August, 1973.
7. AVL Monitoring Systems Study, prepared for the National Science Foundation by the Jet Propulsion Laboratory, JPL-5040-26, June 30, 1976.
8. A Study of the Application of an Automatic Vehicle Monitoring System to the Operation of the Boston Police Department - Urban Sciences Inc., 1972.
9. Evaluation of an Implemented AVM System - Larson, Colton, and Larson 1976 Carnahan Conference on Crime and Countermeasures, University of Kentucky.
10. Vehicle Location and Status Reporting System (LOCATES) Phase II Final Report, City of Montclair Police Department, March, 1974.
11. Task Force Report: Science and Technology, The President's Commission on Law Enforcement and Administration of Justice (Appendix B by Herbert Isaacs), 1967.
12. Analysis of Current Detroit Police Department Dispatch Functions, Detroit Police Department, June, 1968.

13. Urban Police Patrol Analysis - Richard Larson, M.I.T. Press, 1972.
14. Application of Automatic Vehicle Location in Law Enforcement - An Introductory Planning Guide - Hansen and Leflang, C.I.T. Jet Propulsion Laboratory, 15 January, 1976, Rept. JPL 5040-17 (NTIC #N76-24087).
15. Automatic Vehicle Location Systems for Law Enforcement Applications (4 vol.'s) - Prepared for L.E.A.A. by the Aerospace Corporation July, 1976, Report ATR-76(7914-01)-1.
16. Patrol Force Allocation for Law Enforcement - An Introductory Planning Guide - John and Kennedy, C.I.T. Jet Propulsion Laboratory, Report JPL 5040-18, 16 February 1976. (NTIS #N76-24084).
17. Comprehensive Traffic and Transportation Inventory - Wilbur Smith and Associates - Boston Regional Planning Project - Sept. 1965.
18. Transportation Facts for the Boston Region - Boston Redevelopment Authority - Michael Gruenbaum, Editor, 1968.
19. Modal Split (Nine Methods for Estimating Transit Usage) Fertal, Weiner, Balek, and Sevin - U.S. Department of Commerce, Bureau of Public Roads, December, 1966.
20. Urban Mass Transit Planning - edited by Wolfgang Homburger, University of California (Berkeley), 1967.
21. The Urban Transportation Problem - Meyer, Kain, and Wohl, Harvard University Press, 1965.
22. Transportation and Parking for Tomorrow's Cities - Wilbur Smith and Associates, New Haven, Conn., 1966.
23. Urban Transportation (Demand and Coordination) - Highway Research Board Bulletin 326; January, 1962.
24. Investigation of Closed-Loop Bus Control Strategies in Accordance with Schedule - John Ward and Paul Houpt, ESL-R-715, January 1977. M.I.T. Electronic Systems Laboratory.
25. A Dead-Reckoning Map Correlation System for Automatic Vehicle Tracking, Lezniak, Lewis, and McMillen, IEEE Transactions on Vehicular Technology, Vol. VT-26, No. 1, February 1977, pp. 47-60.
26. Results of an AM Broadcast AVL Experiment, Skomal, IEEE Transactions on Vehicular Technology, Vol. VT-26, No. 1, February 1977, pp. 11-18.
27. Benefit and Economic Impact of the MBTA Bus Radio Management In-formation and Control System - Ralph Dandrea, Project Manager, July, 1976, Massachusetts Bay Transportation Authority.

28. Differential Loran-C Time Stability Study, Robert B. Goddard, Report No. DOT-CG-31146-A, U.S. Coast Guard, November, 1973.
29. Emergency Vehicle Location and Status Reporting System for the City of Philadelphia, Teledyne Systems Co., November, 1975.
30. Summary Report, The Dial-A-Ride Transportation System, M.I.T. Urban Systems Laboratory USL-TR-70-10, Daniel Roos, et al, 1970.
31. Scheduling Algorithms for a Dial-A-Ride System, M.I.T. Urban Systems Laboratory, USL-TR-70-13, Nigel Wilson, et al, March, 1971.
32. Recent Advances in Computer Control Procedures for Demand Responsive Transportation Systems - Nigel Wilson and Eric Miller, ORSA/TIMS Joint National Meeting, November 3-5, 1976.
33. Anatomy of a Systems Failure: Dial-A-Ride in Santa Clara County, California, Robert Carlson, Transportation 5 (1976).
34. A Comparative Analysis of Area Navigation Systems for General Aviation - Steven Dodge - M.I.T. Dept. of Aeronautics and Astronautics, Flight Transportation Laboratory, FTL R74-1, June, 1973.
35. Implementation of Area Navigation in the National Airspace System - Clark, Bolz, Solomon, and Stephenson, Champlain Technology report for FAA-SRDS; August, 1975.
36. New York Air Traffic Capacity Study [Real Time Simulation] FAA-SRDS; FAA-RD-70-7; February, 1970.
37. Simulation Studies of Airborne Traffic Situation Display Applications - Final Report - Mark Connelly, M.I.T. Electronic Systems Laboratory, May, 1977. Report ESL-R-751.
38. Study of Aircraft-Centered Navigation, Guidance, and Traffic Situation System Concept for Terminal-Area Operation - Anderson, Will, and Grantham, NASA-Langley Research Center (NASA TN D-6992), November, 1972.
39. Simulation of 4D RNAV in the Terminal Area - Tobias and Erzberger, NASA-Ames Research Center; Systems, Man, and Cybernetics Conference, Dallas; October, 1974.
40. Strategic Control Algorithm Development; R.L. Erwin, et al; Boeing Commercial Airplane Company; - Report DOT-TSC-OST-74-3 (4 volumes), August, 1974.
41. The National Aviation System; Challenges of the Decade Ahead (1977 - 1986) - D.O.T. - Federal Aviation Administration. (Unnumbered Brochure.)

42. The Politics of Urban Transportation Innovation - Alan Altshuler, Technology Review; May, 1977.
43. AVM System for Los Angeles Transit - RFP TSC/432-0017-RN July 24, 1975 - Issued by the D.O.T. Transportation Systems Center; Cambridge, Mass.
44. "Monitor-CTA", Final Report, Martin Lukes, Raymond Shea, Chicago Transit Authority for U.S. Department of Transportation, Report No. UMTA-IL-06-0010-73-1, 1973.
45. Analysis and Comparison of Some Automatic Vehicle Monitoring Systems - Buck, Esposito, and Unkauf, DOT-TSC-OST-72-32, July, 1973.
46. Urban Field Tests of Four Vehicle Location Techniques - Scales, Mitre Corporation for U.S. Dept. of Transportation, UMTA-VA-06-0012-73-1, 1973.
47. Ekofisk Test Report - Pulse/8, Kongsberg Navigation, Sept. 1976.
48. Tor Field -- Report on Location of Wellhead, Kongsberg Navigation, October 3, 1976.
49. Performance of a Loran-C Receiver in an Urban Environment, Constantine I. Photopoulos, Bachelor of Science Thesis, Department of Electrical Engineering and Computer Science, M.I.T., May 1977.
50. A Suggested Action Program for the Relief of Airfield Congestion at Selected Airports, L.N. Mullion, et al, Federal Aviation Administration, April 1969, AD 689 107.
51. Cracking the Tanker Safety Problem, Juan Cameron, Fortune Magazine, April 1977.
52. Boating Statistics 1976, U.S. Coast Guard, Report CG-357
53. They Fight Oil Spills All over the World, Boston Globe (Parade Supplement), April 10, 1977.
54. 8th Annual Report, U.S. Department of Transportation, Fiscal Year 1974.
55. "St. Mary's River Mini Loran-C Precision Navigation Demonstration, Sault Ste. Marie, Michigan, June 23-30, July 19-21, 1977", Megapulse, Inc./Internav Corp., Bedford, MA. 01730
56. The Statistical Abstract of the U.S., Bureau of the Census, Department of Commerce, Issued October, 1976.
57. Transportation Crime: The Scope of the Problem, Transportation and Distribution Management, July, 1972.

58. Loran-C User Handbook, Coast Guard Publication CG-462, August 1974.
59. Experiments on Four Different Techniques for Automatically Locating Land Vehicles, B.E. Blood and B.W.A. Kliem, Report No. UMTA-MA-06-0041-77-2, DOT/Transportation Systems Center, Cambridge, MA, June 1977.
60. Evaluation of the Monitor - CTA Automatic Vehicle Monitoring System, H.G. Miller and W.M. Basham, Report No. UMTA-MA06-0024-74-1, DOT/Transportation Systems Center, March 1974 (Final Report).
61. F.C.C. Rules and Regulations, Vol. V., Sections 89.120, 91.120, and 93.120, December 1974 Edition, as amended through February, 1978.
62. FLAIR -- Fleet Location and Information Reporting, The FLAIR System, Document D246-2004-2, The Boeing Company, August 1975.
63. Boeing FLAIR<sup>TM</sup> AVM System -- Philadelphia Tracking Test, R.A. McMillen, Document D246-2031-1, The Boeing Company, January 21, 1977.
64. A Study of Urban Mass Transportation Needs and Financing - U.S. Department of Transportation, - July, 1974.
65. Stockholm: A Planned City - Goran Sidenblad, Scientific American; September, 1965.
66. Voice and Data Transmission in a Mobile Radio Channel at 850 MHz, G.A. Arredono and J.L. Smith, IEEE Transactions on Vehicular Technology, Vol. No. 1, February, 1977, pp. 88-93.
67. Docket No. 21142, Federal Communications Commission, Notice of Proposed Rule Making, March 9, 1977 (In the matter of Amendment of Parts 89, 91, 93, and 95 ... to eliminate the low pass audio filtering requirements in digital voice, AVM, and other high bit rate digital applications.)
68. Carrier Transmission of Binary Data in a Restricted Band, Tjhung and Wittke, IEEE Transactions on Communication Technology, Vol. COM-18, No. 4, August 1970, pp. 295-304.
69. Limit-Discriminator Detection Performance of Manchester and NRG Coded FSK, Cartier, D.E., IEEE Transactions on Aerospace and Electronic Systems, Vol. AES-13, No. 1, January 1977, pp. 62-70.
70. Tracking Performance of Symbol Synchronizers for Manchester Coded Data, Simon, M.K., and Lindsey, W.C., IEEE Transactions on Communications, Vol. COM-25, No. 4, April 1977, pp. 393-408.
71. Spectral Occupancy of Digital Angle-Modulation Signals, Prabhu, V.K., The Bell System Technical Journal, Vol. 56, No. 4, April 1976, pp. 426-493.
72. Performance of Biphase Digital FM Transmission, Kwan, C.Y., Simpson, R.S., and Batson, B.H., IEEE Transactions on Communications, Vol. COM-25, No. 5, May 1977, p.564 (Correspondence).

73. SE 205 Mobile Radio, Ketterling, H.P., and Klein, M.P., Electrical Communications (ITT), Vol. 51, No. 4, 1976.
74. Investigation of Digital Mobile Radio Communications, Thomas C. Kelly and John E. Ward, Electronic Systems Laboratory, M.I.T., U.S. Department of Justice Report, USGPO Stock No. 2700-00233, October, 1973.
75. Modulation Noise and Spectral Analysis, Panter, Phillip F., New York, McGraw-Hill 1965; Chapter II, "Interference in FM Reception".
76. Mobile Loran-C Tests in Boston Area, Connelly, Mark, M.I.T. - ESL. Memorandum, November 12, 1977.
77. National Plan for Navigation; A. Goldsmith, Editor; U.S. Department of Transportation; November, 1977.

APPENDIX D

Report Of New Technology

The work performed under this contract, while leading to no invention, has produced several innovative concepts on the use of terrestrial radio determination techniques for law enforcement, emergency services, public transportation, and trucking. In addition, the critical technical questions that must be addressed prior to the practical implementation of these concepts have been identified.

