

Referena
85-26

UMTA-MA-06-0153-85-12
DOT-TSC-UMTA-85-26



U.S. Department
of Transportation

**Urban Mass
Transportation
Administration**

Laboratory and Field Testing of NYCTA Power Frequency Track Circuits

Michael D. West
F. Ross Holmstrom

Transportation Systems Center
Cambridge, MA 02142

February 1986
Final Report

This document is available to the public
through the National Technical Information
Service, Springfield, Virginia 22161.

UMTA Technical Assistance Program

NOTICE

This document is disseminated under the sponsorship of the Department of Transportation in the interest of information exchange. The United States Government assumes no liability for its contents or use thereof.

NOTICE

The United States Government does not endorse products or manufacturers. Trade or manufacturers' names appear herein solely because they are considered essential to the object of this report.

1. Report No UMTA-MA-06-0153-85-12	2. Government Accession No.	3. Recipient's Catalog No.	
4. Title and Subtitle LABORATORY AND FIELD TESTING OF NYCTA POWER FREQUENCY TRACK CIRCUITS		5. Report Date February 1986	
		6. Performing Organization Code DTS-77	
7. Author(s) Michael D. West and F. Ross Holmstrom		8. Performing Organization Report No. DOT-TSC-UMTA-85-26	
		10. Work Unit No. (TRAIS) UM576/R5615	
9. Performing Organization Name and Address U.S. Department of Transportation Research and Special Programs Administration Transportation Systems Center Cambridge, MA 02142		11. Contract or Grant No.	
		13. Type of Report and Period Covered Final Report November 1982 - April 1983	
12. Sponsoring Agency Name and Address U.S. Department of Transportation Urban Mass Transportation Administration Office of Technical Assistance Office of Systems Engineering Washington, DC 20590		14. Sponsoring Agency Code URT-12	
		15. Supplementary Notes	
16. Abstract <p>This report addresses the possible electromagnetic interference between the electronic AC propulsion control systems and the signaling and train control systems. The potential exists for AC-drive propulsion systems to cause EMI that can adversely affect the operation of NYCTA's power-frequency track circuits. Harmonic components of the variable-frequency propulsion currents generated by the inverters conceivably could leak onto the third rail and then be magnetically coupled to the track circuits.</p> <p>General operating characteristics of the track circuits, test methods, and results are presented in this report. A good qualitative picture of overall NYCTA track circuit susceptibility to EMI was obtained. Each of the thirteen track circuits tested in the lab gave precise and repeatable results. Results obtained from the field tests of three track circuits were more variable, due to variability of conditions; however, results from the field were very similar to those obtained in the lab. The data from these measurements have been provided to the equipment manufacturers involved in the AC propulsion program and to the NYCTA.</p>			
17. Key Words Electromagnetic Interference, AC Propulsion, Rail Transit Power Frequency Signaling Systems		18. Distribution Statement DOCUMENT IS AVAILABLE TO THE PUBLIC THROUGH THE NATIONAL TECHNICAL INFORMATION SERVICE, SPRINGFIELD VIRGINIA 22161	
19. Security Classif. (of this report) UNCLASSIFIED	20. Security Classif. (of this page) UNCLASSIFIED	21. No. of Pages 90	22. Price

PREFACE

As part of the program for Subsystem Technology Applications to Rail Systems (STARS), AC-driven systems for rapid transit cars are being developed for demonstration in the United States. The AC-drive systems will utilize on-board electronically controlled static inverters to transform the DC propulsion power from the third rail to AC power for running the induction motors used for propulsion.

The Transportation System Center of the U.S. Department of Transportation, under the sponsorship of the Urban Mass Transportation Administration, conducted a series of laboratory measurements to assess the operating and EMI characteristics of New York Transit Authority (NYCTA) power-frequency signaling equipment.

Special thanks go to Lennart Long of DOT/TSC whose encouragement and support were instrumental in the completion of this project and to Paul Poirier of DOT/TSC who supervised the overall laboratory and field testing effort.

In addition, the authors wish to express gratitude to Sam Powell, Nabil Ghaly, and all other NYCTA personnel who provided us with their time, facilities and general support in this effort.

The authors also wish to thank Bob Rudich of AiResearch Mfg. Co. Division of Garrett Corp, Bill Truman of Westinghouse Electric Corp., Jim Hoelscher of GRS, Inc., Don Stark of U.S. & S Division of American Standard, Inc. and the rest of the EMI/EMC technical working group for the direction and technical expertise they provided for the duration of the program. Thanks also to Irving Golini of DOT/TSC who acted as equipment manager during the field testing portion of the program and who constructed some of the test equipment in the DOT/TSC laboratory and to Chuck Edelson of System Development Corp. for his invaluable supervision of a portion of the field testing.

Final thanks go to Ronald Kangas, Chief of the Design Division, UMTA Office of Systems Engineering, whose office sponsored the UMTA program in rail transit EMI/EMC under which this effort proceeded.

METRIC CONVERSION FACTORS

Approximate Conversions to Metric Measures

Symbol	When You Know	Multiply by	To Find	Symbol
LENGTH				
in	inches	~2.5	centimeters	cm
ft	feet	30	centimeters	cm
yd	yards	0.9	meters	m
mi	miles	1.6	kilometers	km
AREA				
in ²	square inches	6.5	square centimeters	cm ²
ft ²	square feet	0.09	square meters	m ²
yd ²	square yards	0.8	square meters	m ²
mi ²	square miles	2.6	square kilometers	km ²
	acres	0.4	hectares	ha
MASS (weight)				
oz	ounces	28	grams	g
lb	pounds	0.45	kilograms	kg
	short tons (2000 lb)	0.9	tonnes	t
VOLUME				
tsp	teaspoons	5	milliliters	ml
Tbsp	tablespoons	15	milliliters	ml
fl oz	fluid ounces	30	milliliters	ml
c	cups	0.24	liters	l
pt	pints	0.47	liters	l
qt	quarts	0.95	liters	l
gal	gallons	3.8	liters	l
ft ³	cubic feet	0.03	cubic meters	m ³
yd ³	cubic yards	0.76	cubic meters	m ³
TEMPERATURE (exact)				
°F	Fahrenheit temperature	5/9 (after subtracting 32)	Celsius temperature	°C

Approximate Conversions from Metric Measures

Symbol	When You Know	Multiply by	To Find	Symbol
LENGTH				
mm	millimeters	0.04	inches	in
cm	centimeters	0.4	inches	in
m	meters	3.3	feet	ft
m	meters	1.1	yards	yd
km	kilometers	0.6	miles	mi
AREA				
cm ²	square centimeters	0.16	square inches	in ²
m ²	square meters	1.2	square yards	yd ²
km ²	square kilometers	0.4	square miles	mi ²
ha	hectares (10,000 m ²)	2.5	acres	
MASS (weight)				
g	grams	0.035	ounces	oz
kg	kilograms	2.2	pounds	lb
t	tonnes (1000 kg)	1.1	short tons	
VOLUME				
ml	milliliters	0.03	fluid ounces	fl oz
l	liters	2.1	pints	pt
l	liters	1.06	quarts	qt
l	liters	0.26	gallons	gal
m ³	cubic meters	36	cubic feet	ft ³
m ³	cubic meters	1.3	cubic yards	yd ³
TEMPERATURE (exact)				
°C	Celsius temperature	9/5 (then add 32)	Fahrenheit temperature	°F

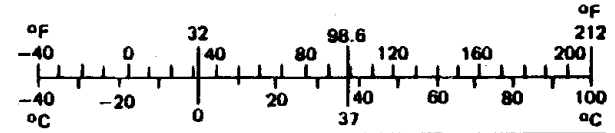
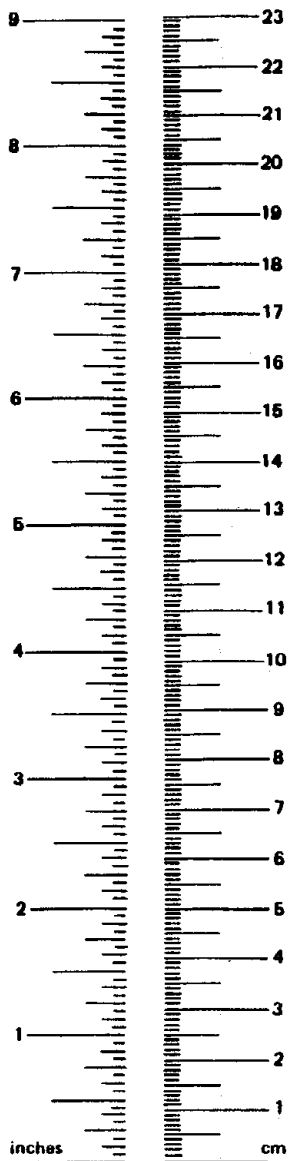

^a 1 in. = 2.54 cm (exactly). For other exact conversions and more detail tables see NBS Misc. Publ. 286, Units of Weight and Measure, Price \$2.25 SD Catalog No. C13 10 286.

17

TABLE OF CONTENTS

<u>Section</u>	<u>Page</u>
EXECUTIVE SUMMARY.....	vii
1. INTRODUCTION.....	1
2. POWER-FREQUENCY TRACK CIRCUITS.....	2
3. EMI CHARACTERIZATION OF TRACK CIRCUITS.....	8
4. NYCTA EMI SUSCEPTIBILITY LABORATORY TEST PROCEDURES AND RESULTS.....	9
4.1 Startup and General Test Procedures.....	9
4.2 Drop Response Characteristics of Picked Up Track Relays..	11
4.3 Pickup Response Characteristics of Dropped Track Relays..	12
4.4 Static Phase Shift.....	12
4.5 EMI Interference for the Occupied Case.....	13
4.6 EMI Interference for the Unoccupied Case.....	14
5. NYCTA EMI FIELD TEST PROCEDURES AND RESULTS.....	15
5.1 Setup and General Test Procedures.....	15
5.2 Notes on Track Circuit No. F3A-834.....	16
5.3 Notes on Track Circuit No. E4-744.....	17
5.4 Notes on Track Circuit No. D-1492.....	18
6. CONCLUSIONS.....	19
APPENDIX A - DATA FROM NYCTA TRACK CIRCUITS TESTED IN THE LABORATORY..	A-1
APPENDIX B - DATA FROM FIELD TESTS ON NYCTA TRACK CIRCUITS.....	B-1
APPENDIX C - EMI EFFECTS ON VANE RELAY TRACK CIRCUITS D.E. Start & A.G. Erlich, U.S.& S.....	C-1
APPENDIX D - EMI SUSCEPTIBILITY CHARACTERISTICS - POWER FREQUENCY TRACK CIRCUITS USING VANE RELAYS D.E. Start, U.S.& S.....	D-1

LIST OF ILLUSTRATIONS

<u>Figure</u>		<u>Page</u>
1.	A SINGLE-RAIL POWER-FREQUENCY TRACK CIRCUIT.....	1
2.	RECEIVING-END CIRCUITS USING REACTANCES.....	5
3.	A TYPICAL TWO-RAIL POWER-FREQUENCY TRACK CIRCUIT.....	7
4.	THE TEST APPARATUS AND ITS INSTALLATION IN THE LAB.....	10
5.	CONFIGURATION OF THE KEPCO MODEL BOP36-5M OP AMP-TYPE POWER SUPPLY.....	11

EXECUTIVE SUMMARY

As part of the program for Subsystem Technology Applications to Rail Systems (STARS), being undertaken by the Urban Mass Transportation Administration (UMTA), AC-drive systems for rapid transit cars are being developed for demonstration in the U.S. These systems will utilize on-board electronically controlled static inverters to transform the DC propulsion power from the third rail to AC power for running the induction motors used for propulsion. The potential payoff is greatly reduced maintenance expenses, due to the elimination of the moving mechanical parts in the electromechanical power controllers still used in many U.S. rapid transit systems, and in the DC motors currently used by all.

One potential problem that must be addressed if the benefits of AC propulsion are to be realized is that of possible electromagnetic interference between the electronic AC propulsion control systems and the signaling and train control systems.

The subway system of the New York City Transit Authority (NYCTA) will be the site for tests of AC-drive rapid transit cars. The potential exists for AC-drive propulsion systems to cause EMI that can adversely affect the operation of NYCTA's power-frequency track circuits. Harmonic components of the variable-frequency propulsion currents generated by the inverters conceivably could leak onto the third rail and then be magnetically coupled to the track circuits.

General operating characteristics of the track circuits, test methods, and results are presented in this report. A good qualitative picture of overall NYCTA track circuit susceptibility to EMI was obtained. Each of the thirteen track circuit tested in the lab gave precise and repeatable results. Results obtained from the field tests of three track circuits were more variable, due to variability of conditions; however, results from the field were very similar to those obtained in the lab. The data from these measurements have been provided to the equipment manufacturers involved in the AC propulsion program and to the NYCTA.



1. INTRODUCTION

The New York City Transit Authority (NYCTA) has been chosen at the site for future tests of domestic AC propulsion rapid transit cars. Preliminary technical analysis has shown that AC propulsion systems on rail transit cars will have the potential to interfere with power-frequency signaling systems. To minimize future operational problems at NYCTA, a program has been undertaken to measure the susceptibility of NYCTA power-frequency signaling systems to external EMI. The purpose of this report is to present the results of this effort to date.

The Transportation Systems Center of the U.S. Department of Transportation, under the sponsorship of the Urban Mass Transportation Administration, conducted a series of laboratory measurements to assess the operating and EMI characteristics of NYCTA power-frequency signaling equipment. The laboratory measurements were made under highly controlled conditions. To relate the results of the laboratory tests to real-world conditions, similar tests were performed on operational power-frequency signaling equipment in the field at NYCTA. General agreement was found between laboratory and field results. However, the electrical environment in which the signaling equipment actually operates in the field was found to differ in some respects from the highly idealized situation in the laboratory.

Comparison of laboratory and field results shows that a fairly accurate assessment of the EMI characteristics of power-frequency track circuits can be made, based on laboratory analysis. This fact should aid the EMI analysis of future rail transit systems employing power-frequency track circuits where AC propulsion systems might be introduced.

2. POWER-FREQUENCY TRACK CIRCUITS

Power-frequency track circuits are so called because they operate at frequencies used for primary power distribution. The most prevalent primary power distribution frequency in North America currently is 60 Hz, although in the past other frequencies were employed, most notably 25 Hz. The NYCTA primarily uses 60 Hz track circuits, although a number of 25 Hz track circuits are still in operation.

Power to operate the 60 Hz circuits comes directly from 110 vac 60 Hz power lines. Power for the 25 Hz circuits is provided by motor-generator sets.

Figure 1 shows a single-rail power-frequency track circuit utilizing a dual-element vane relay. The vane relay has two separate magnetic circuits: one energized by a 110 vac "local" winding, and the other by a low-voltage "track" winding. One winding produces an AC magnetic field that induces an AC eddy current in a metal vane that pivots up and down about a horizontal axis. The other winding produces another AC magnetic field that creates an $(I \times B)$ force by reacting with the AC current in the vane. The resulting force lifts the vane, thus opening the "back" contacts and closing the "front" contacts of the relay. When no train is present in the track circuit, the track winding is energized, and the relay is "picked up," back contacts are open, and front contacts are closed. When a train is present in the track circuit, the circuit carrying signal current to the track winding is shorted by the train, causing the relay to be "dropped," thus opening the front contacts and closing the back contacts. (A more detailed description of power-frequency signaling system operation is given in Appendices C and D of this report.)

Difference in phase of local and track currents in the relay is of critical importance to its operation, since maximum lifting force is generated on the vane when the induced current in the vane and the magnetic field with which it reacts are exactly in phase. As is seen in the test results in Appendix A, there is an inverse-cosine relationship between the relative phase variation of signals applied to the local and track windings, and the amplitude of track signal required to pick up the relay.

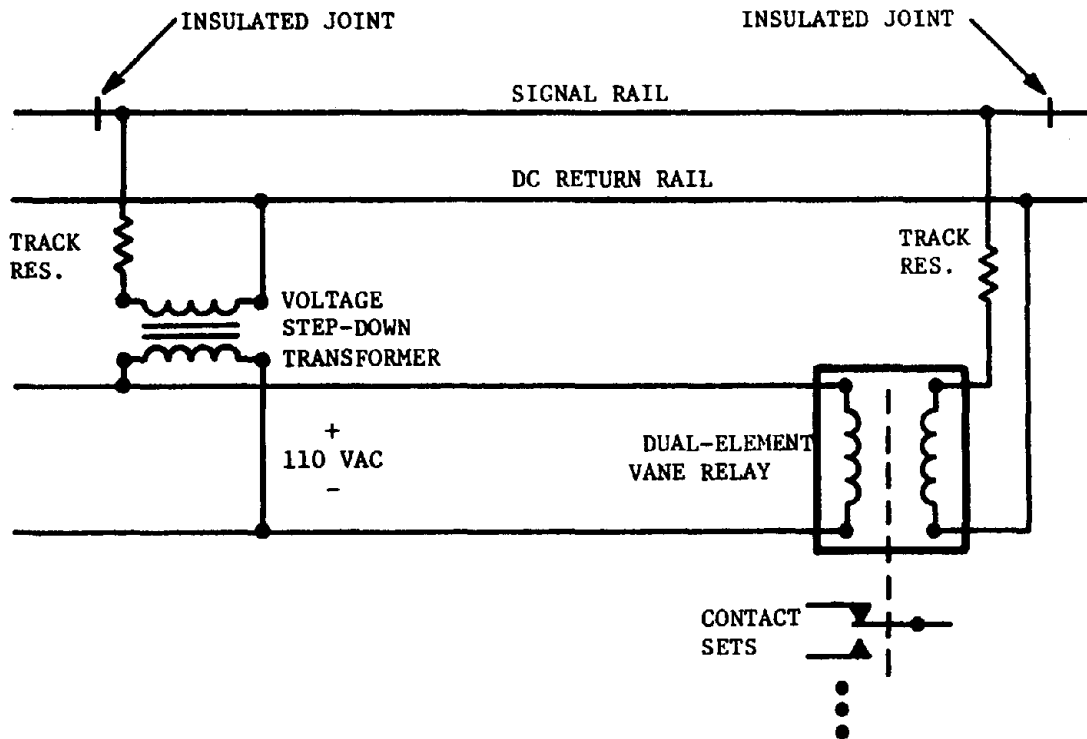

FIGURE 1. A SINGLE-RAIL POWER-FREQUENCY TRACK CIRCUIT

If the signal applied to the track winding is at a slightly different frequency than the local winding signal, the relay will periodically lift and drop, as the two signals drift in and out of proper phase.

For a fixed level of local winding current I_L , there is a threshold for the track winding current I_T below which the back contacts of the relay will be closed. A higher threshold for I_T exists above which the front contacts will be closed. The normal "working" current level specified for a track relay when the track circuit is unoccupied is generally between 1.15 times and 1.9 times the threshold for front contact closure. Inspection of a number of relay nameplates indicates that a typical ratio is 1.5:1.

To provide optimum phase relationship between the local and track signals applied to the relay, or to reduce DC propulsion current through the relay, reactive elements are often placed between the track and the track terminals of a relay. Figures 2a and 2b illustrate two such situations. Figure 2a shows an element called a shielding reactor shunting the relay terminals, and Figure 2b shows a series capacitor.

To determine operating characteristics of the track circuit, it was necessary to measure phase angles of all voltages and currents relative to a single reference. The reference chosen for phase was the line voltage V_L .

In a number of locations, NYCTA uses two-rail track circuits. This type of track circuit is used in especially long blocks. Figure 3 shows a representative configuration of a two-rail track circuit. Note that in this type of circuit, insulated joints are used in both rails at each end of the block, and a center-tapped inductor called an impedance bond is used to provide a balanced DC return path for propulsion current.

Some two-rail track circuits employ track relays of the two-phase rotary type. These relays are essentially two-phase torque motors, with one armature winding energized by the local signal and the other by the track signal. The two armature magnetic fields have phases approximately 90 degrees apart, and together yield a rotating magnetic field that produces a torque on the rotor, causing it to rotate and actuate the contacts. Threshold characteristics and phase characteristics of rotary relays are qualitatively similar to those of vane relays. However, rotary relays generally operate at lower levels of track voltage and current than do vane relays.

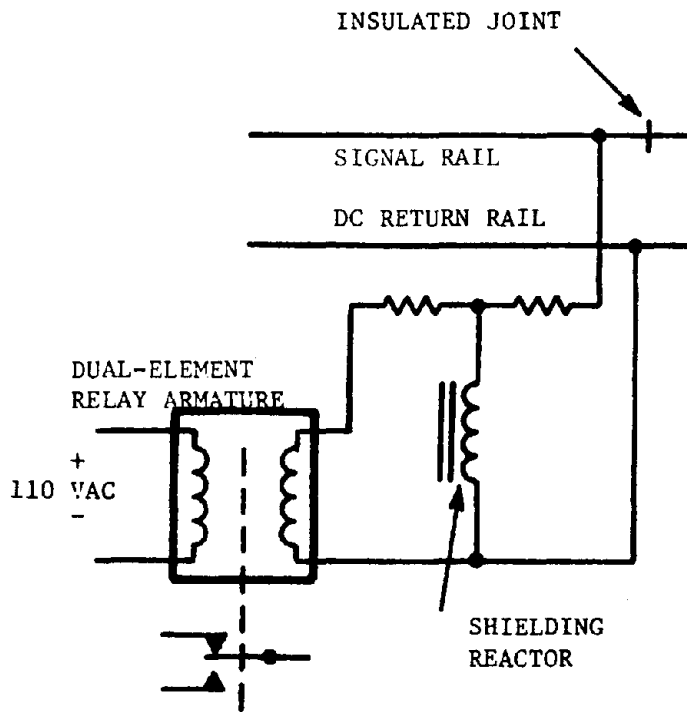

FIGURE 2a. RECEIVING-END CIRCUIT USING A SHIELDING REACTOR TO REDUCE DC CURRENT THROUGH TRACK WINDING OF RELAY

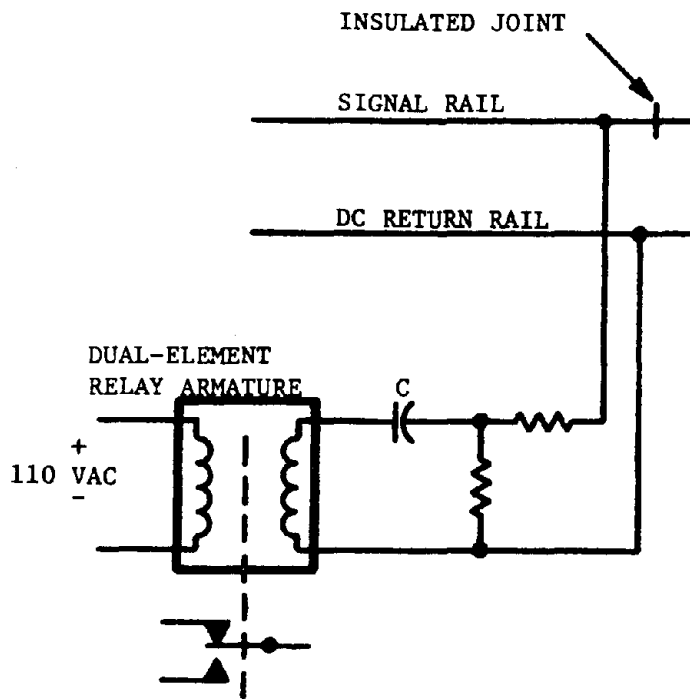

FIGURE 2b. RECEIVING-END CIRCUIT USING CAPACITOR TO ELIMINATE DC CURRENT THROUGH TRACK WINDING OF RELAY

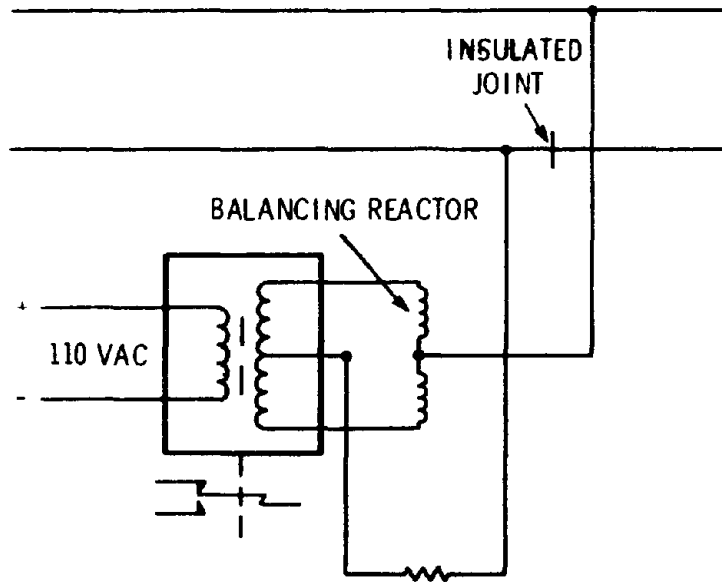

FIGURE 2c. RECEIVING-END CIRCUIT USING BALANCING REACTOR

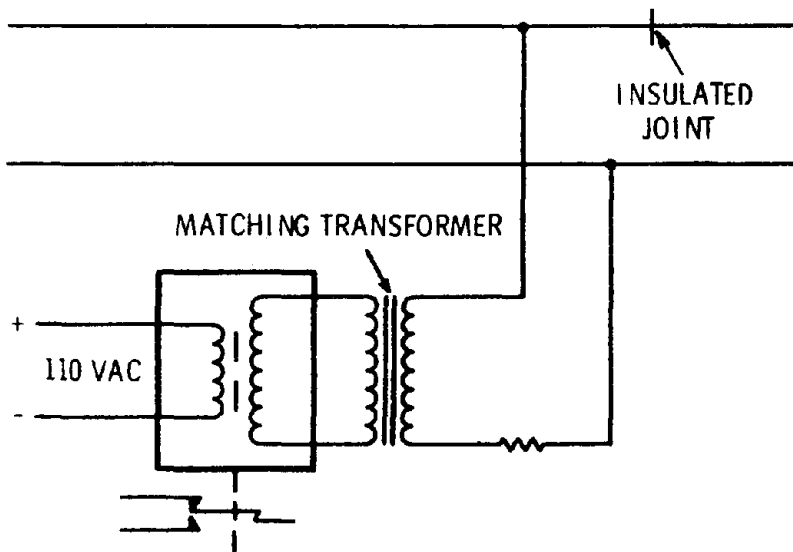

FIGURE 2d. RECEIVING-END CIRCUIT USING MATCHING TRANSFORMER

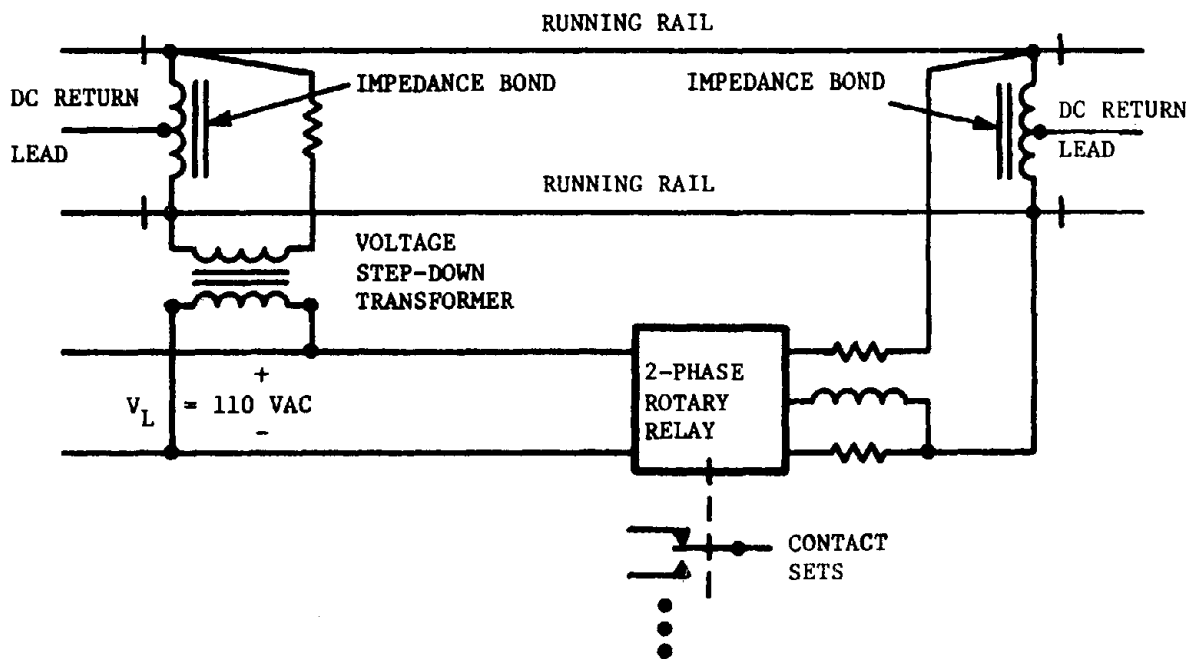

FIGURE 3. A TYPICAL TWO-RAIL POWER-FREQUENCY TRACK CIRCUIT

3. EMI CHARACTERIZATION OF TRACK CIRCUITS

Two separate mechanisms are recognized whereby electromagnetic interference can be coupled into a track circuit. The first of these is inductive interference, and the second is conductive interference. Modeling and analysis of the magnetic coupling between electrical components on the car and the running rails, and between the third rail and running rails, can provide information on the voltage and current waveforms of EMI present at the track leads of the track relay. The impedance characteristics of third rail and running rails, ballast, and impedance bonds, as well as the mutual impedance between the third rail and running rails, all play a role in determining the EMI characteristics of track circuits. (Ref's 1-4.)

The subject of this report is the related problem of assessing the response of a track circuit to EMI, given that certain types of EMI signals appear at its receiving-end track terminals. There are two cases to consider: the occupied case, and the unoccupied case.

In the occupied case, no valid track signal is being received by the track relay; and the question is, what type of interfering signal will cause the track relay to falsely lift. In the unoccupied case, the normal track signal is present at the track relay; and the question is, what type of interfering signal will cause the relay to drop.

The sections that follow outline the results of measurements of current and voltage levels, and of relative phases and frequencies, that lead to circuit malfunction for the occupied and unoccupied cases.

4. NYCTA EMI SUSCEPTIBILITY LABORATORY TEST PROCEDURES AND RESULTS

4.1 STARTUP AND GENERAL TEST PROCEDURES

The following procedures were followed for establishing the base-line operating conditions for each track circuit tested in the lab. Each track circuit was set up in the lab according to instructions supplied by NYCTA. Voltage and current amplitudes and phases were measured and recorded. Current amplitudes were obtained by measuring voltage across 0.1 ohm current-sampling resistors. Voltages were measured using an HP 3403A true-rms voltmeter. Relative phases were measured using an HP 3582A network analyzer or an oscilloscope. The voltage, V_L , applied to the primary winding of the track transformer and to the "local" winding of the track relay was supplied by a Variac for the 60 Hz track circuits and by an Elgar Model 1001 AC Power Source for the 25 Hz track circuits.

Next, the test apparatus was inserted between the track transformer of the track circuit and the track leads to the relay, as shown in Figure 4. The purpose of the test apparatus was to allow for injection of interfering signals in a prescribed fashion, and for alteration of the phase of track signal applied to the track relay. The test apparatus consisted of an adjustable phase shifter and a KEPCO op amp-type power amplifier. The phase shifter and power amplifier were adjusted to vary the amplitude and phase of signal to the track terminals of the relay, with the desired deviation from values present before the test apparatus was installed. Installation of the test apparatus for each specific track circuit tested is pictured in the corresponding circuit diagram in Appendix A.

Figure 5 shows the connection of the KEPCO amplifier for its use in summing the track signal and interfering signal.

An ohmmeter was used to detect the opening and closing of front and back relay contacts. The 1-kohm scale was used, and the threshold conditions that were recorded for the threshold of front contact closure or back contact opening were those for which the needle of the meter was barely fluttering, even if intermittently.

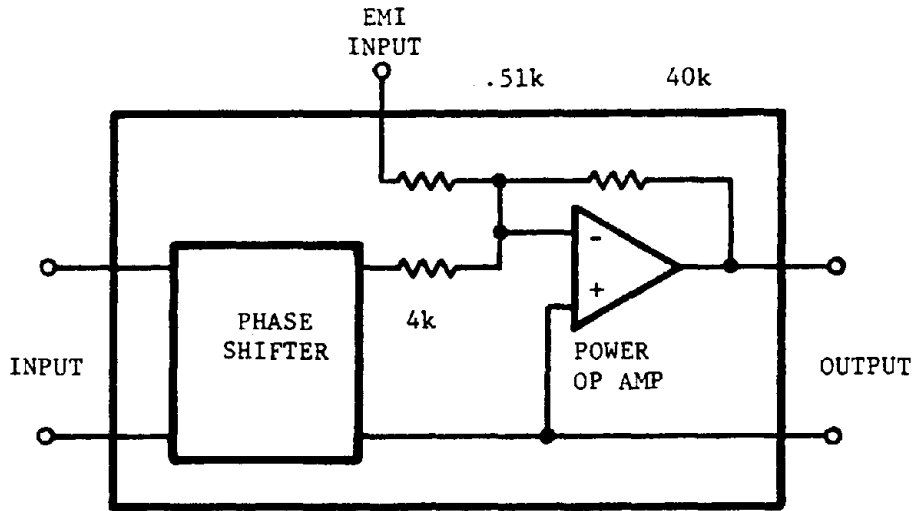

a. Test apparatus

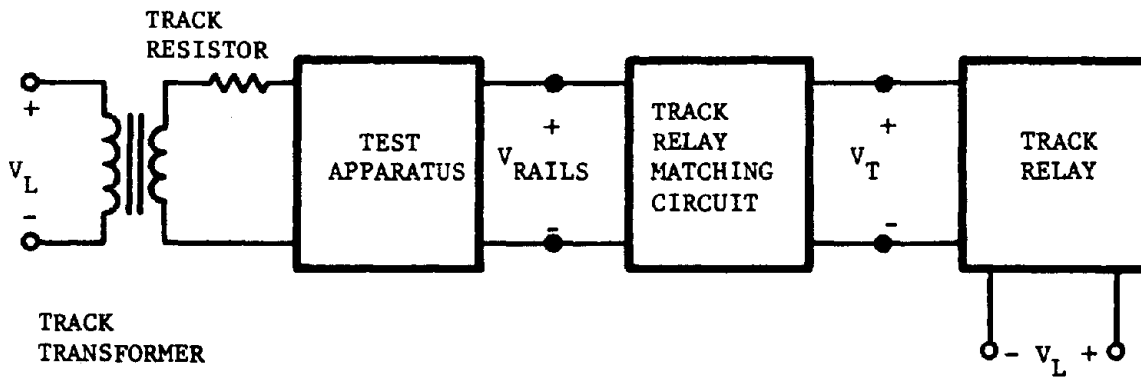

b. Installation of test apparatus in lab

FIGURE 4. THE TEST APPARATUS AND ITS INSTALLATION IN THE LAB

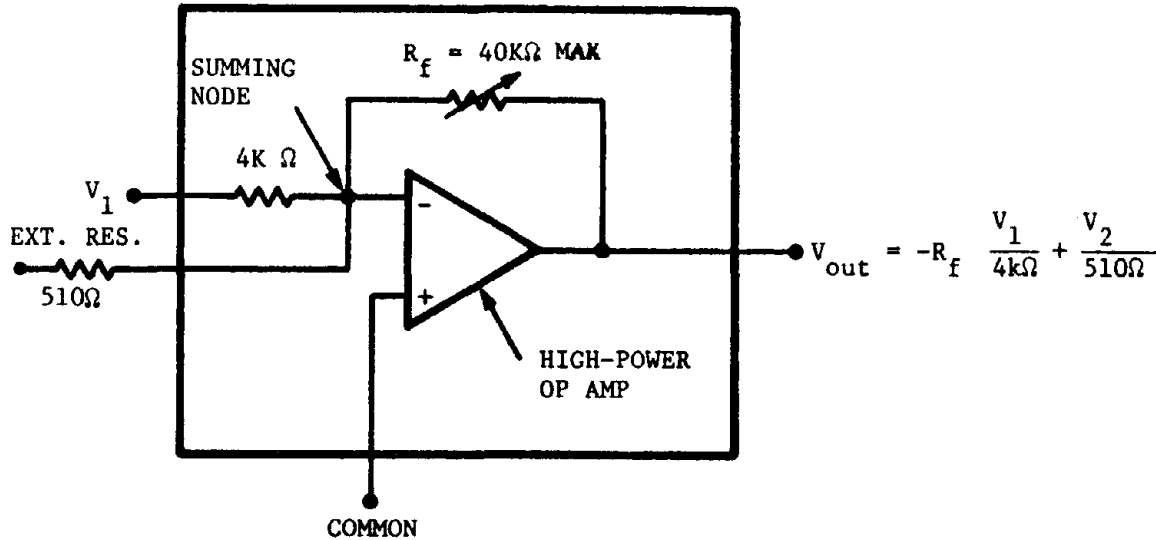

FIGURE 5. CONFIGURATION OF THE KEPCO MODEL BOP36-5M OP AMP-TYPE POWER SUPPLY

4.2 DROP RESPONSE CHARACTERISTICS OF PICKED UP TRACK RELAYS

The purpose of this test was to measure the drop response characteristics of track relays when a normally present signal was interrupted for varying durations. In each case the circuit was set up as shown in Figure 4.

A normally-closed contact pair of a small relay was inserted between the output of the phase shifter and the track signal input of the amplifier. The relay contacts were opened intermittently by applying a signal from a pulse generator to the coil of the relay. Interruptions of desired duration were triggered by pressing the manual trigger button on the pulse generator.

The duration t_I for which the signal was interrupted was adjusted until the front track relay contacts barely opened. This duration, defined as t_{IF0} , was measured by using a storage oscilloscope sweeping at low speed to observe the

voltage across the contacts of the small relay. Values of t_{IF0} were recorded for each of six combinations of amplitude of V_L and V_T . Three values of V_T were used: normal, and normal ± 10 volts (± 5 v in 25 Hz circuits). Two values of V_L were used: normal, and 10 v less (5 v less in 25 Hz circuits).

Values of t_{IF0} as a function of V_L and V_T are shown on the data sheets for each case in Appendix A.

4.3 PICKUP RESPONSE CHARACTERISTICS OF DROPPED TRACK RELAYS

The purpose of this test was to measure the pickup response characteristics of track relays to bursts of track signal as a function of amplitude and duration. The circuit was set as for the previous test, except that a normally open contact pair of the small relay was placed in series between the phase shifter and amplifier.

The burst duration t_B of track signal the relay was increased until the front contacts of the track relay barely closed. The minimum value for which closure occurred, defined as t_{BFC} , was measured by using a storage oscilloscope sweeping at slow speed to observe the voltage across the small relay. This test was repeated for six different combinations of V_L and V_T applied to the track relay. Two values of V_L were used: normal, and 10 v higher (5 v higher in 25 Hz circuits). Three values of V_T were used: normal, and normal ± 10 v (± 5 v in 25 Hz circuits).

Values of t_{BFC} as a function of V_L and V_T are shown on the data sheets for each case in Appendix A.

4.4 STATIC PHASE SHIFT

The purpose of this test was to measure the rms voltage level of the track signal required to close the front relay contacts as a function of phase difference of rail voltage V_{RAILS} and line voltage V_L . In this test the phase relationship between V_{RAILS} and V_L was varied by the phase shifter. For each phase setting the gain of the amplifier was adjusted until the contacts of the relay just barely opened or closed as indicated by the ohmmeter.

Because of static friction in the armature of the track relay, there was hysteresis in the relation between V_{RAILS} and relay armature position. A higher

value of V_{RAILS} was required to lift the relay armature and close the front contacts than was required to keep them closed thereafter. To experimentally determine the average of the values of V_{RAILS} for which the front contacts closed and reopened, the gain of the amplifier was varied back and forth until the value of V_{RAILS} resulted that was in the middle of the hysteresis loop, and the contacts were balanced between opening and closing. The values of V_{RAILS} thus determined are plotted in Appendix A for each track circuit tested, with the data labelled "EFFECTS OF HYSTERESIS MINIMIZED." The vertical axes of these graphs are labelled "VRMS (RAILS)," and the horizontal axes of the graphs giving the phase difference between V_{RAILS} and V_L is labelled "PHASE (DEGREES)."

To assess the complete extent of hysteresis, for specific values of phase difference V_{RAILS} was increased from 0 until the front contacts closed, then decreased until they reopened. Resulting values of V_{RAILS} are plotted, with the data labelled "CLOSED TO OPEN" and "OPEN TO CLOSED."

4.5 EMI INTERFERENCE FOR THE OCCUPIED CASE

This test was a measure of the relationship between the frequency and amplitude of V_{RAILS} that leads to periodic closure of the track relay's front contacts. In this case, V_{RAILS} is assumed to be an interfering signal, with the normal track signal absent.

This test used the lab setup shown in the the data sheets in Appendix A with the lead from phase shifter to amplifier disconnected. A signal from the frequency synthesizer was fed into the amplifier via the 510-ohm input resistor, at the point in the diagram labelled "EMI." Measurements were made for specific values of frequency of V_{RAILS} near the normal operating frequency of the track circuit. Since the rail signal was at a different frequency than the V_L , it would periodically pass through the optimum phase for lifting the relay armature. Thus, for small frequency difference, the armature would bob up and down in a periodic fashion. For larger frequency difference it would vibrate. At each frequency, signal amplitude was increased until the front contacts barely closed at the top of the armature's travel, as indicated by an ohmmeter across the contacts.

Depending on the specific track circuit, frequency was varied over a range from 5 to 15 Hz below the operating frequency to 5 to 15 Hz above the operating frequency. Frequency deviation was limited by the constraints that current into the control winding of the relay should be less than 2 amperes, and the vane of the relay should not impact too violently against its stops. This test was performed for V_L at its normal level, and for V_L 10 volts above normal (5 v above normal for 25 Hz track circuits).

Data are shown in Appendix A on graphs labelled "INTERFERING VOLTAGE ACROSS RAIL FOR OCCUPIED CASE," with frequency of interfering signal given in Hz, and interfering signal V_{RAILS} shown as "VRMS (RAILS)."

4.6 EMI INTERFERENCE FOR THE UNOCCUPIED CASE

The purpose of this test was to measure the amplitude and frequency characteristics of an added interfering signal that would lead to periodic opening of a track relay's front contacts when the track relay was initially picked up. During this test, the normal track signal was present. The interfering signal generated by the frequency synthesizer was summed with the normal operating signal using the amplifier as a summing amplifier. Frequency range of the interfering signal, and constraints on frequency range, were the same as in the occupied case just described. Measurements were made for V_L at its normal level, and for V_L 10 volts below normal (5 v below normal for 25 Hz circuits).

For each frequency of interfering signal, its amplitude was increased until the front contacts of the relay barely opened as indicated by the ohmmeter. (Once again, this opening occurred periodically due to the frequency difference.) Then the normal operating signal into the amplifier was disconnected and the amplitude of interfering signal at the rail contacts was measured.

Data are shown in graphs labelled "INTERFERING VOLTAGE ACROSS RAILS FOR OCCUPIED CASE."

The information gained from having repeated the EMI interference measurements on a limited set of track circuits for the occupied and unoccupied cases leads us to believe that results of measurements are repeatable to within approximately 5 percent at worst.

5. NYCTA EMI FIELD TEST PROCEDURES AND RESULTS

5.1 SETUP AND GENERAL TEST PROCEDURES

Three track circuits in actual revenue operation at NYCTA were tested, and the field test data are shown in Appendix B. The procedures used correspond to the lab procedures outlined in Section 4.2 for measuring the pickup response characteristics of dropped track relays, and in Section 4.3 for measuring the drop response characteristics of picked-up relays.

The first track circuit chosen for field test was NYCTA No. E4-744, and was a GRS 25 Hz double-rail track circuit with impedance bonds. This circuit could not be tested in the laboratory because the impedance bonds were too unwieldy to move there.

The second was NYCTA No. F3A-834, and was a US&S 60 Hz track circuit using a type VG-12 shielding reactor. A circuit of this type was later retested in the laboratory so that the lab data could be compared with the field results.

The third track circuit was NYCTA No. D-1492, and was a US&S 60 Hz track circuit using a type VG-10 shielding reactor.

The test setup for performing field tests is shown in Figure B-1, pg. B-2, in Appendix B. For performing measurements, the test apparatus shown in the figure could be inserted either at the transmitting end or receiving end of the circuit. When inserted at the transmitting end, a 1:1 isolation transformer was placed between the amplifier output and the track leads. When inserted at the receiving end, the 1:1 isolation transformer was placed between the track leads and phase shifter input.

For each of the three track circuits tested in the field, the following general procedures were followed: With the track circuitry in its normal operating state, measurements were made of the line voltage V_L and current I_L delivered to the local winding of the relay, as defined in Figure A-1a, pg. A-3. Next, voltage V_{RAILS} and current I_{RAILS} , present in the leads between track circuitry and rails, were measured.

As was done in the laboratory, current was measured by observing voltage across a 0.1-ohm current sampling resistor placed in the circuit. All phase angles were measured relative to the phase of V_L . Relative phases were measured using an HP 3582 network analyzer. Resistive voltage dividers and isolation transformers were used as shown in Figure B-1, pg. B-2 to derive a low-voltage signal proportional to V_L that could be fed safely to the network analyzer. The isolation transformers used for this purpose caused negligible phase shift.

Then the test apparatus was inserted at the receiving end of the track circuit as shown in Figure B-1, and the phase shifter and amplifier were adjusted to yield the amplitudes and phases for V_{RAILS} and I_{RAILS} that match normal operation. Then, the tests outlined in Sections 4.2 and 4.3 were performed.

Next, the test apparatus was removed from the receiving end and installed at the transmitting end of the track circuit. The phase shifter and amplifier were adjusted to give the values of V_{RAILS} and I_{RAILS} corresponding to original normal operating values at the transmitting end, and the tests outlined in Sections 4.2 and 4.3 were repeated.

Data are shown in graphs in Appendix B labelled "INTERFERING VOLTAGE ACROSS LEADS FROM RAILS AT RECEIVING END," and "INTERFERING VOLTAGE ACROSS LEADS TO RAILS AT FEED END." Values of voltage V_{RAILS} given are the threshold values of interfering signal for the front track relay contacts to close in the occupied case, and to open in the unoccupied case.

5.2 NOTES ON TRACK CIRCUIT NO. F3A-834

At the receiving end of the circuit, values of $V_{RAILS} = 4.70_{-5^{\circ}}$ volts and $I_{RAILS} = 1.10_{-29^{\circ}}$ amps were measured. At the feed end, the corresponding values were $V_{RAILS} = 6.10_{6^{\circ}}$ volts and $I_{RAILS} = 1.54_{-25^{\circ}}$ amps. These measurements were taken while the track circuit was dry. However, most of the testing at the feed end was performed in the rain.

This circuit was retested in the laboratory for verification. On analyzing the results of the field measurements, it was noted that the sum of the interfering 60.1 Hz signal needed to break the contacts for the unoccupied case plus the interfering 60.1 Hz signal needed to close the contacts for the occupied case did not approximately equal the recorded operating receiving-end value of V_{RAILS} as would be expected. The gain of the amplifier, which was to have been held constant for this portion of the field test may have been increased accidentally. An increase of 0.6 volts in normal operating V_{RAILS} signal level above the 4.7-volt level originally measured would account for the discrepancy. In the lab, V_{RAILS} was set at 5.75 volts for the unoccupied test. There is excellent agreement--less than 10 percent difference--between field and lab data for the receiving-end occupied case.

It should be noted that field measurements of V_L using an HP true-rms meter are greater than the comparable lab measurements by approximately 2 percent. This difference is due to the presence of harmonics that exist in V_L in the field.

5.3 NOTES ON TRACK CIRCUIT NO. E4-744

At the receiving end of the double-rail track circuit values of $V_{RAILS} = 0.21/80^\circ$ volts and $I_{RAILS} = 0.71/31^\circ$ amps were measured. The feed end of the track circuit required more power to drive it than could be provided with the amplifier, due to the low shunt impedance of the impedance bonds. Therefore measurements were only conducted at the receiving end.

5.4 NOTES ON TRACK CIRCUIT NO. D-1492

At the receiving end of this track circuit measured values of voltage and current were $V_{RAILS} = 3.87/24^\circ$ volts and $I_{RAILS} = 0.83/-44^\circ$ amps. At the feed end the corresponding values were $V_{RAILS} = 6.69/4^\circ$ volts and $I_{RAILS} = 1.97/-14^\circ$ amps.

The waveform of V_{RAILS} was very jagged, due to what appeared to be substantial content of 720 Hz harmonic.

6. CONCLUSIONS

The track circuit types selected for testing were representative of the major extent of the NYCTA signaling system. A total of 16 different types of track circuits were tested, including 13 in the laboratory, 2 in the field, and one at both lab and field. The circuit types that were not tested are essentially "one of a kind" -- 3 types of 25 Hz track circuits restricted to the Jamaica Line, the Rockaway section of the Canarsie Line, and the Corona yard track. Since NYCTA plans to phase out the 25 Hz track circuits soon, it is not believed to be appropriate for AC propulsion equipment manufacturers to include data on these track circuits when developing design criteria for their systems.

The body of data obtained in the laboratory presents a good qualitative picture of overall NYCTA track circuit susceptibility to EMI. Each track circuit tested in the lab gave precise and repeatable results for the given components and configuration used in the test setup. As shown in Appendix B, the results at the receiving end of NYCTA track circuit No. F3A-834 correlate very well with the test results obtained in the laboratory.

In general, each track circuit's susceptibility to EMI can vary by a significant amount as a function of voltage applied to the rails at the transmitting end (adjustable via taps on the secondary of the track transformer), and as a function of the selected resistor values. Selection of applied track voltage and resistances depends on track circuit length, ballast resistance, and the judgement of the signaling system maintenance personnel.

REFERENCES

1. "Recommended Practices for Rail Transit Intra-System Electromagnetic Compatibility of Vehicular Electrical Power and Track Circuit Signaling Subsystems," Volume I: Inductive Recommended Practices, and Volume II: Conductive Recommended Practices, May 1982.
2. Hoelscher, J., and R. Rudich, "Compatibility of Rate-Coded Audio Frequency Track Circuits with Chopper Propulsion Drive in Transit Systems," Proceedings of the 1982 Conference on Railways in the Electronic Age, London, England.
3. Krempasky, J.F., G.E. Clark, and L.A. Frasco, "EMI/EMC Rail Testing Program at WMATA," presented at the APTA Rapid Transit Conference, Cleveland, June 1982.
4. Holmstrom, F.R., "Conductive Interference in Rapid Transit Signaling Systems," Proceedings of the IEEE Industrial Applications Society 1985 Convention, Toronto, October 1985.



APPENDIX A
DATA FROM NYCTA TRACK CIRCUITS TESTED IN LABORATORY

Data are listed in this appendix for the track circuits tested in the lab.

<u>Entry No.</u>	<u>Mfgr.</u>	<u>Freq.</u>	<u>Description</u>	<u>Page</u>
A-1			General Laboratory Test Setup	A-2
A-2	US&S	25 Hz	PTV-42 relay	A-4
A-3	US&S	25 Hz	Model 15	A-6
A-4	GRS	25 Hz	Balancing reactor rotor type	A-8
A-5	GRS	60 Hz	Balancing reactor rotor type	A-10
A-6	GRS	60 Hz	Balancing reactor vane type	A-12
A-7	US&S	60 Hz	Matching transformer with PTV-42 relay	A-14
A-8			Retest of Entry A-7	A-16
A-9	US&S	60 Hz	Matching transformer with PV-250 relay	A-18
A-10	GRS	60 Hz	With matching transformer	A-20
A-11	US&S	60 Hz	With matching transformer - double rail	A-23
A-12	GRS	60 Hz	With matching transformer - double rail	A-26
A-13	GRS	60 Hz	Capacitor type	A-28
A-14	US&S	60 Hz	Capacitor type	A-30
A-15	US&S	60 Hz	Shielding reactor type	A-32

The data for each of the track circuit entries A-2 - A-15 contain the following pages of information:

1. Figure a: Receiving End Circuit / Data sheet: table of normal operating values of voltage, currents, and impedances as shown in Figure a and Figure A-1 of the General Laboratory Test setup diagram; table of t_{IF0} , the duration of interruption of V_{RAILS} signal in the unoccupied case leading to opening of front contacts, vs. track relay control terminal voltage V_T , for measurements described in Sec. 4.2; table of t_{BFC} , the duration of application of V_{RAILS} signal in the occupied case, leading the closing of front contacts vs. V_T , for measurements described in Sec. 4.6; and, signaling equipment list.
2. Figure b: Graph of magnitude of V_{RAILS} required to close front contacts as a function of phase difference between V_{RAILS} and V_L , for measurements described in Sec. 4.4.

3. Figure c: Graph of magnitude of interfering signal in the absence of normal V_{RAILS} that causes front contacts to close, vs. frequency of interfering signal. This corresponds to the occupied case measurements described in Sec. 4.5.
4. Figure d: Graph of magnitude of interfering signal added to normal V_{RAILS} that causes front contacts to open, vs. frequency of interfering signal. This corresponds to the unoccupied case measurements described in Sec. 4.6.

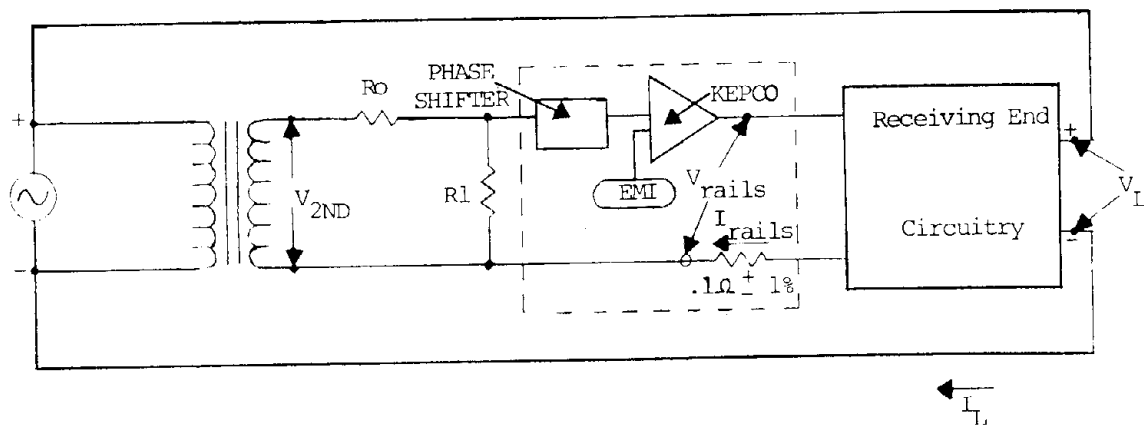

FIGURE A-1. GENERAL TEST SETUP

Figure A-1 shows the general laboratory test set up used to test each track circuit's susceptibility to EMI. The dashed outline encompasses the laboratory instrumentation inserted to generate the simulated interference. The individual receiving end circuit diagrams are included in each track circuit's data sheets. The operating voltages, currents and component impedance values shown in Figure A-1 and in the receiving end circuitry are also given in the data sheets. In some of the test set ups resistor, R_1 , is omitted.

All of the voltage measurements taken were recorded as RMS values. The voltage measurement, V_{RAILS} , represents the voltage across the track at the receiving end of the track circuit. The current, I_{RAILS} , which represents the track circuit current was determined by measuring the voltage across the .1 ohm precision resistor.

US&S 25 Hz Track Signaling Circuit Using PTV-42 Relay

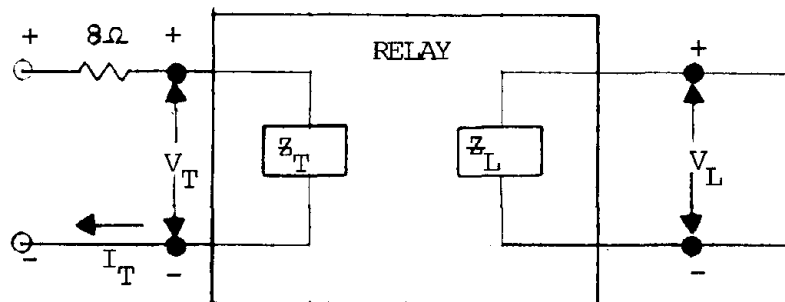

FIGURE A-2a. RECEIVING END CIRCUIT

Normal Operating Values (Without Test Apparatus)

$$V_L = 55 \angle 0^\circ \text{ (Reference)}$$

$$I_L = .32 \angle -86^\circ$$

$$V_{RAILS} = 7.8 \angle -14^\circ$$

$$I_{RAILS} = .93 \angle -21^\circ$$

$$R_0 = 2.5 \text{ Ohms}$$

$$V_T = .966 \angle 54^\circ \text{ (.047} \angle 160^\circ \text{ induced by } V_L)$$

$$I_T = .93 \angle -21^\circ \text{ (} Z_T = .27 + j1.0)$$

$$V_{2ND} = 10.1 \angle -16^\circ$$

$$R_1 \text{ omitted}$$

Occupied Injection of 25 Hz Signal

V_L (Ref)	$V_T = V_{CONTROL}$	t_{bfc} , sec.	#Cycles
55	$7.10 \angle -14^\circ$.17	4.2
55	$7.81 \angle -14^\circ$.15	3.8
55	$8.52 \angle -14^\circ$.14	3.4
60	$7.10 \angle -14^\circ$.16	4.0
60	$7.81 \angle -14^\circ$.14	3.5
60	$8.52 \angle -14^\circ$.12	3.0

Unoccupied Interruption of 25 Hz Signal

V_L (Ref)	$V_T = V_{CONTROL}$	t_{ifo} , sec.	#Cycles
50	$7.10 \angle -14^\circ$.06	1.5
50	$7.81 \angle -14^\circ$.09	2.2
50	$8.52 \angle -14^\circ$.10	2.6
55	$7.10 \angle -14^\circ$.09	2.2
55	$7.81 \angle -14^\circ$.09	2.3
55	$8.52 \angle -14^\circ$.10	2.5

Signaling Equipment

- Vane Relay - U.S. & S. PTV-42, PC 277919, Index SE
57.5 V, 25 Hz, Spec 3891.
- Track Transformer - U.S. & S. 55 V, 25 Hz,
Internal Resistance .2 ohm.

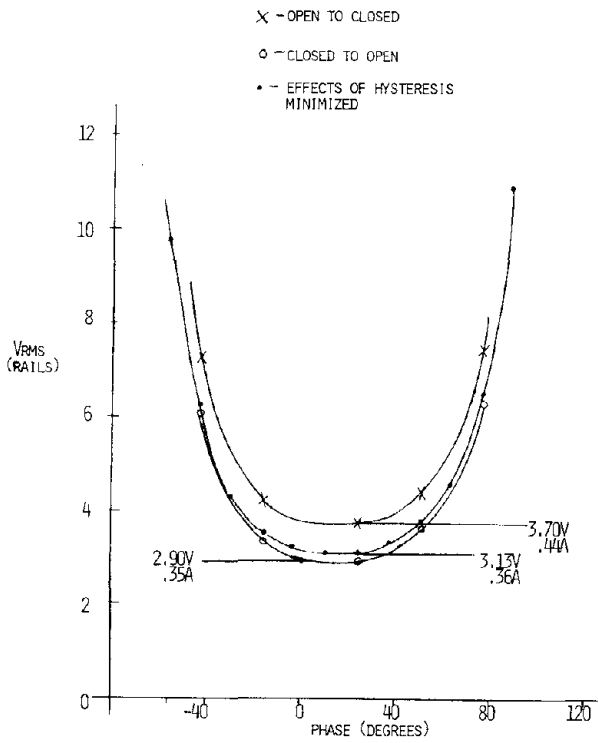

b. STATIC PHASE SHIFT OF 25 Hz SIGNAL ACROSS RAILS - 5/83

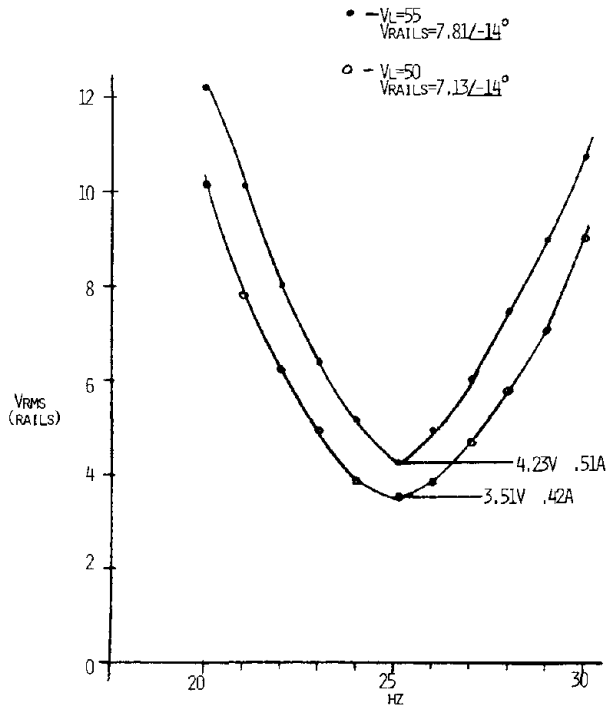

d. INTERFERING VOLTAGE ACROSS RAILS FOR UNOCCUPIED CASE - 5/83

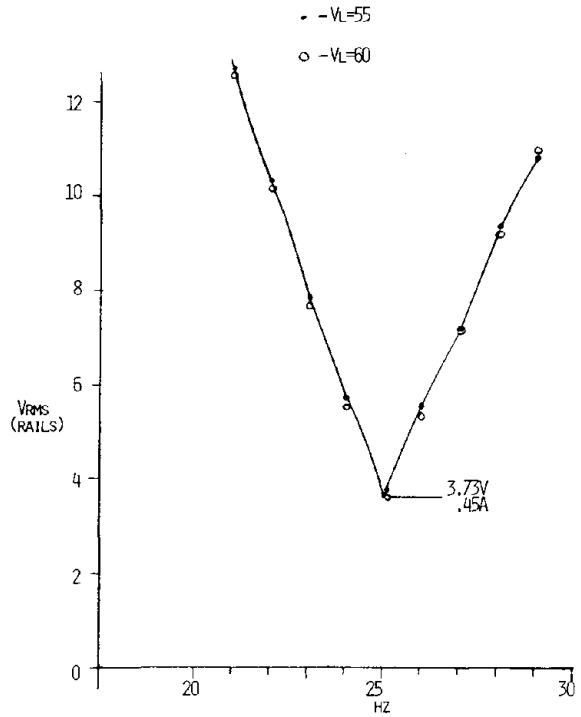

c. INTERFERING VOLTAGE ACROSS, RAILS FOR OCCUPIED CASE - 5/83

FIGURE A-2. US&S 25 Hz TRACK SIGNALING CIRCUIT USING PTV-42 RELAY

US&S 25 Hz Track Signaling Circuit Using Model 15 Relay

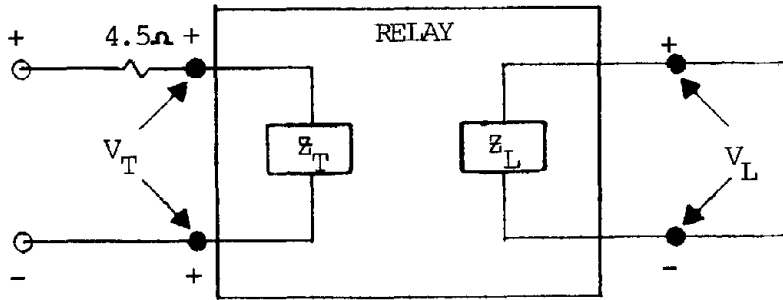

FIGURE A-3a. RECEIVING END CIRCUIT

Normal Operating Values (Without Test Apparatus)

$V_L = 55 \angle 0^\circ$ (Reference) $V_T = 1.73 \angle 51^\circ$ (.034 $\angle 94^\circ$ induced by V_L)
 $I_L = .19 \angle -78^\circ$ ($Z_L = 60.2 + j283$) $I_T = .71 \angle -21^\circ$ ($Z_T = .75 + j2.32$)
 $V_{RAILS} = 4.11 \angle 3^\circ$ $V_{2ND} = 6.1 \angle 0^\circ$
 $I_{RAILS} = .71 \angle -21^\circ$
 $R_0 = 1.0$ Ohms $R_1 = 3.33$ Ohms

Occupied Injection of 25 Hz Signal

V_L (Ref)	$V_T = V_{CONTROL}$	$t_{bfc}, \text{sec.}$	#Cycles
55	$1.57 \angle 51^\circ$.15	3.7
55	$1.73 \angle 51^\circ$.13	3.2
55	$1.89 \angle 51^\circ$.11	2.7
60	$1.57 \angle 51^\circ$.13	3.3
60	$1.73 \angle 51^\circ$.12	2.9
60	$1.89 \angle 51^\circ$.10	2.6

Unoccupied Interruption of 25 Hz signal

V_L (Ref)	$V_T = V_{CONTROL}$	$t_{ifo}, \text{sec.}$	#Cycles
50	$1.57 \angle 51^\circ$.03	.7
50	$1.73 \angle 51^\circ$.04	1.0
50	$1.89 \angle 51^\circ$.06	1.5
55	$1.57 \angle 51^\circ$.06	1.4
55	$1.73 \angle 51^\circ$.06	1.6
55	$1.89 \angle 51^\circ$.07	1.8

Signaling Equipment

- Vane Relay - U.S.&S. Model 15, Style T2V16, 2 Position, Local 55V, .23 A, Spec 1029, Control 1.75V .7A 25 Cycles, Serial A45078
- Track Transformer - U.S. & S. 55 V, 25 Hz, Internal Resistance .2 ohm (Secondary).

- - OPEN TO CLOSED
- × - CLOSED TO OPEN
- - EFFECTS OF HYSTERESIS MINIMIZED

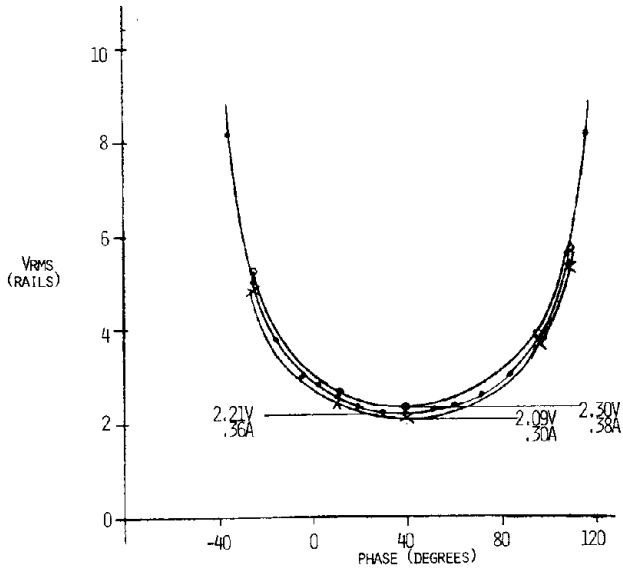

b. STATIC PHASE SHIFT OF 25 HZ SIGNAL ACROSS RAILS - 3/83

- - $V_L=55$
 $V_{RAILS}=4.11 \angle 3^\circ$
- - $V_L=50$
 $V_{RAILS}=3.74 \angle 3^\circ$

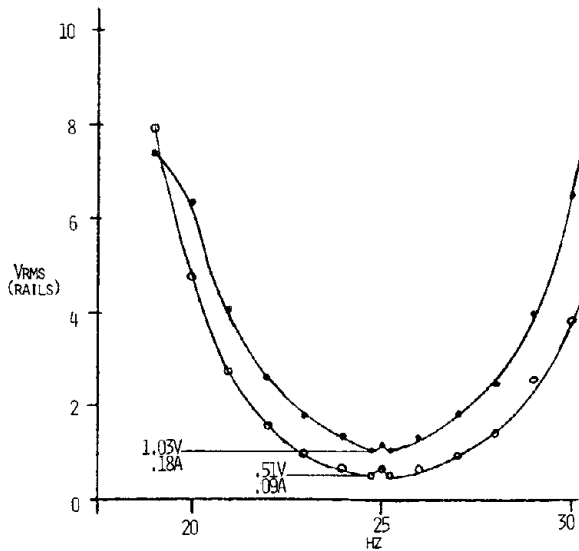

d. INTERFERING VOLTAGE ACROSS RAILS FOR UNOCCUPIED CASE - 3/83

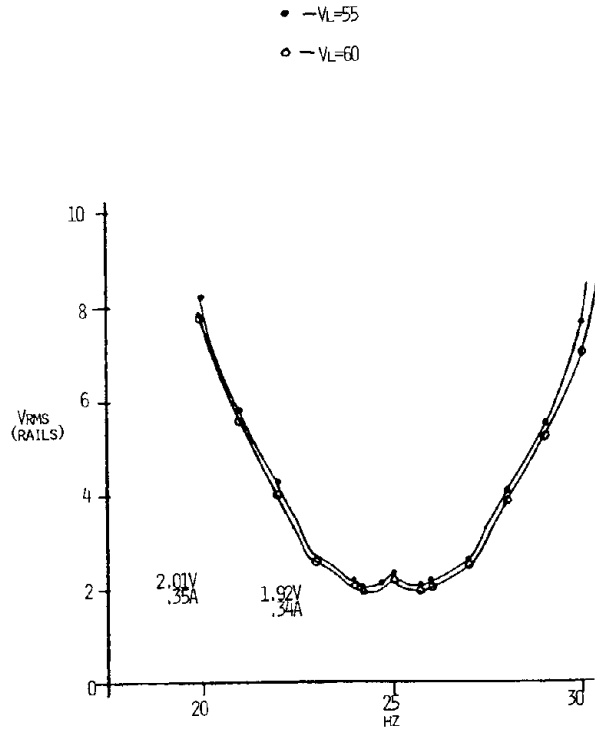

c. INTERFERING VOLTAGE ACROSS RAILS FOR OCCUPIED CASE - 3/83

FIGURE A-3. US&S 25 Hz TRACK SIGNALING CIRCUIT USING MODEL 15 RELAY

GRS Balancing Reactor Rotor Type Single Rail Signal Circuit - 25 Hz

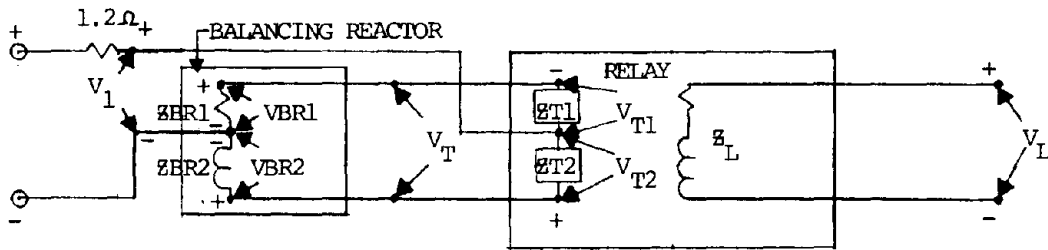

FIGURE A-4a. RECEIVING END CIRCUIT

Normal Operating Values (Without Test Apparatus)

$V_L = 55 \angle 0^\circ$ (Reference)	$V_T = .75 \angle 55^\circ$	$V_1 = 1.48 \angle 11^\circ$
$I_L = .30 \angle -49^\circ$	$V_{T1} = .52 \angle 33^\circ$	$V_{T2} = .34 \angle 94^\circ$
	$Z_{T1} = .44 \angle 30^\circ$	$Z_{T2} = 1.65 \angle -32^\circ$
$V_{RAILS} = 3.03 \angle 2^\circ$	$V_{BR1} = .83 \angle 1^\circ$	$Z_{BR1} = .76 \angle 0^\circ$
$I_{RAILS} = 1.38 \angle -7^\circ$	$V_{BR2} = 1.42 \angle 27^\circ$	$Z_{BR2} = 7.5 \angle 82^\circ$
$V_{2ND} = 6.20 \angle 0^\circ$		
$R_0 = 1.2$ Ohms	$R_1 = 2.1$ Ohms	

Occupied Injection of 25 Hz Signal

V_L (Ref)	$V_T = V_{CONTROL}$	$t_{bfc}, \text{sec.}$	#Cycles
55	$.68 \angle 55^\circ$.18	4.5
55	$.75 \angle 55^\circ$.16	4.0
55	$.82 \angle 55^\circ$.14	3.5
60	$.68 \angle 55^\circ$.17	4.3
60	$.75 \angle 55^\circ$.15	3.8
60	$.82 \angle 55^\circ$.13	3.3

Unoccupied Interruption of 25 Hz signal

V_L (Ref)	$V_T = V_{CONTROL}$	$t_{ifo}, \text{sec.}$	#Cycles
50	$.68 \angle 55^\circ$.10	2.5
50	$.75 \angle 55^\circ$.14	3.5
50	$.82 \angle 55^\circ$.16	4.0
55	$.68 \angle 55^\circ$.14	3.5
55	$.75 \angle 55^\circ$.16	4.0
55	$.82 \angle 55^\circ$.16	4.0

Signaling Equipment

1. Rotor Type Relay - G.R.S. DR No. 36100, List No. 6.5, Serial No. 8808, Class TOA, Position 2, Cycles 25, Phase 2.
2. Track Transformer - U.S. & S. 55 V, 25 Hz, Internal Resistance .2 ohm.
3. Balancing Impedance - G.R.S. DR. No. 42960-1, Serial No. M77030, Resistance .67 Ohms between 1 & 2 and between 2 & 3. Impedance 10.6 between 2 & 3.

- X - OPENED TO CLOSED
- O - CLOSED TO OPENED
- EFFECTS OF HYSTERESIS MINIMIZED

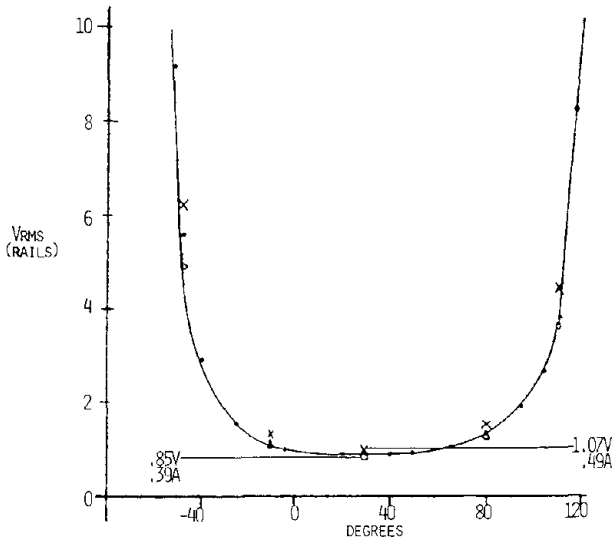

b. STATIC PHASE SHIFT OF 25 Hz
ACROSS RAILS - 3/83

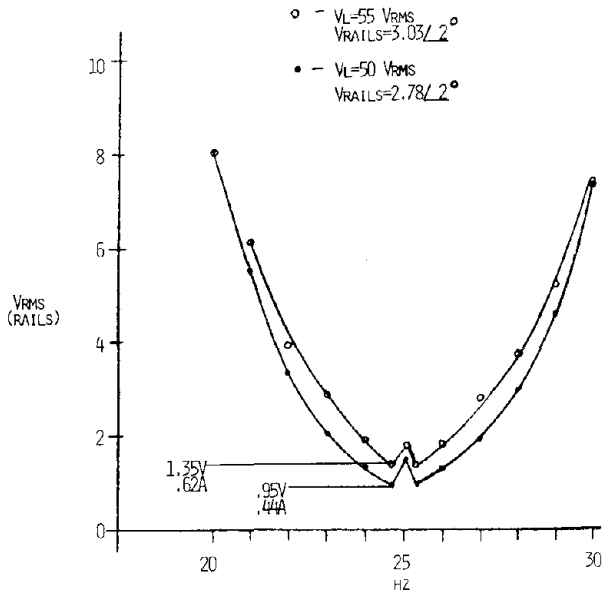

d. INTERFERING VOLTAGE ACROSS RAILS
UNOCCUPIED CASE - 3/83

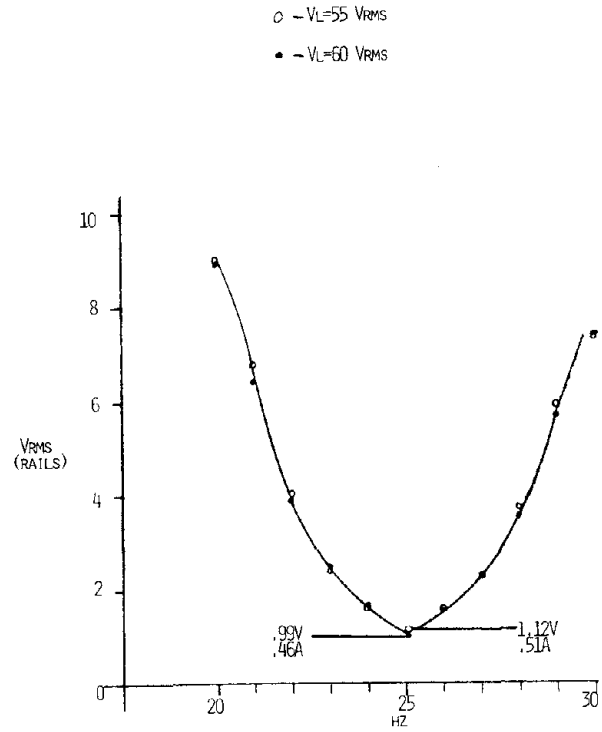

c. INTERFERING VOLTAGE ACROSS RAILS
OCCUPIED CASE - 3/83

FIGURE A-4. GRS BALANCING REACTOR ROTOR TYPE SINGLE RAIL 25 Hz SIGNAL SYSTEM

GRS Balancing Reactor Rotor Type Single Rail Signal Circuit - 60 Hz

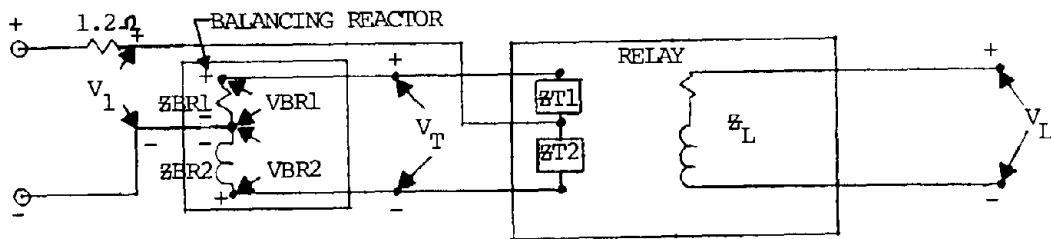

FIGURE A-5a. RECEIVING END CIRCUIT

Normal Operating Values (Without Test Apparatus)

$$\begin{aligned}
 V_L &= 110 \angle 0^\circ \text{ (Reference)} & V_T &= 1.00 \angle 47^\circ \text{ (.002} \angle 180^\circ \text{ induced by } V_L) \\
 I_L &= .26 \angle -50^\circ & V_I &= 1.24 \angle 13^\circ \\
 V_{RAILS} &= 2.22 \angle 3^\circ & V_{2ND} &= 5.21 \angle -1^\circ \\
 I_{RAILS} &= .96 \angle -11^\circ & Z_{BR1} &= .782 \\
 V_{BR1} &= .585 \angle -7^\circ & Z_{BR2} &= 14.7 \angle 86.5^\circ \\
 V_{BR2} &= 1.44 \angle 30^\circ & R_1 &= 1.4 \text{ Ohms} \\
 R_0 &= 1.2 \text{ Ohms} & &
 \end{aligned}$$

Occupied Injection of 60 Hz Signal

V_L (Ref)	$V_T = V_{CONTROL}$	$t_{bfc}, \text{sec.}$	#Cycles
110	.91 $\angle 47^\circ$.16	9.5
110	1.00 $\angle 47^\circ$.15	9.0
110	1.10 $\angle 47^\circ$.13	8.0
120	.91 $\angle 47^\circ$.16	9.5
120	1.00 $\angle 47^\circ$.14	8.5
120	1.10 $\angle 47^\circ$.13	7.5

Unoccupied Interruption of 60 Hz signal

V_L (Ref)	$V_T = V_{CONTROL}$	$t_{ifo}, \text{sec.}$	#Cycles
100	.91 $\angle 47^\circ$.05	3.0
100	1.00 $\angle 47^\circ$.11	6.5
100	1.10 $\angle 47^\circ$.12	7.0
110	.91 $\angle 47^\circ$.11	6.5
110	1.00 $\angle 47^\circ$.12	7.0
110	1.10 $\angle 47^\circ$.13	7.5

Signaling Equipment

1. Rotor Type Relay - G.R.S. Type 2, Size A, Class TQA, Group 6, DR. No. 36100-7, Serial # 23729, Volts Local 110/55, Volts Track 1.0/.5, Position 2 Phase 2, Cycles 60.
2. Track Transformer - G.R.S. DR No. 54940-5, GR4, S.N. 53860, Type 11, Size 1, Cycles 60, KVA .300.
3. Balancing Impedance - G.R.S. DR No. 42960-1, S.N. M77030

- - CLOSED TO OPENED
- × - OPENED TO CLOSED
- - AFFECTS OF HYSTERESIS MINIMIZED

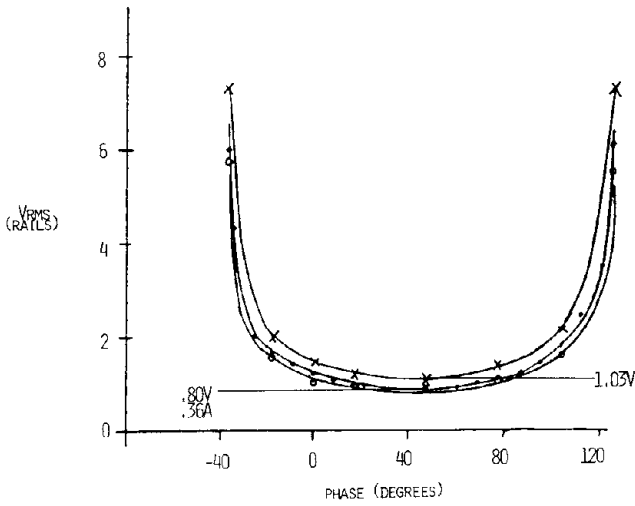

b. STATIC PHASE SHIFT OF 60 HZ ACROSS RAILS - 1/83

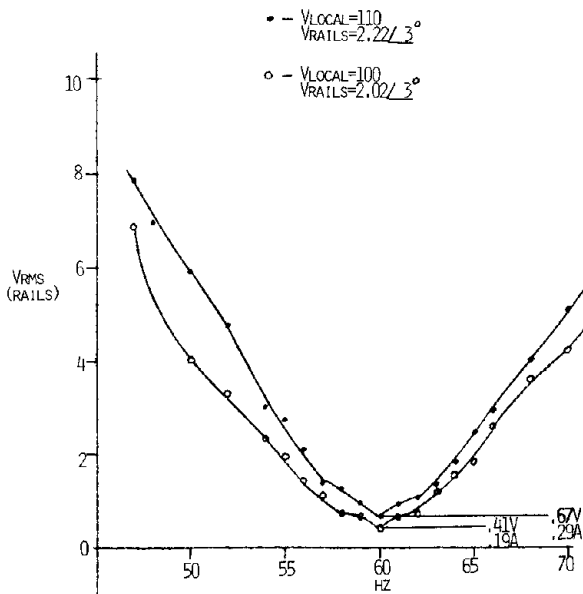

d. INTERFERING VOLTAGE ACROSS RAILS UNOCCUPIED CASE - 1/83

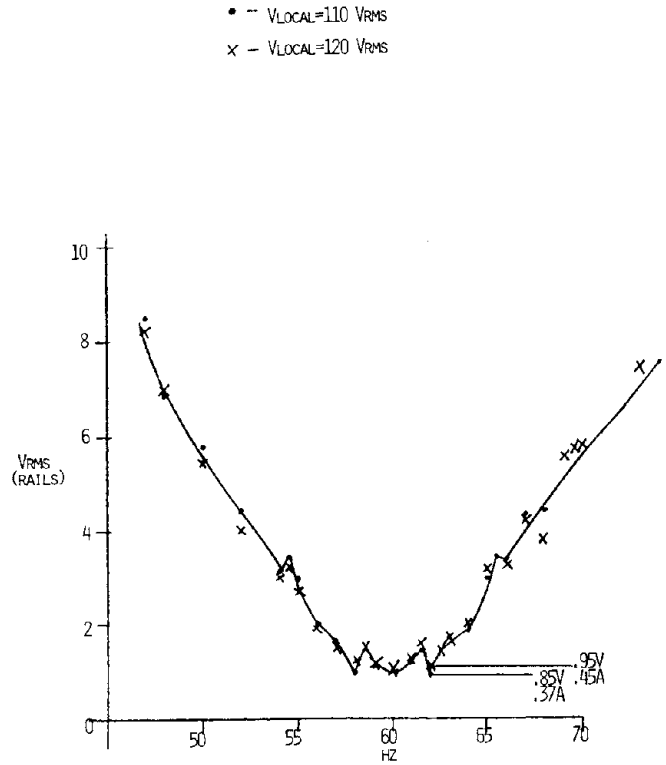

c. INTERFERING VOLTAGE ACROSS RAILS OCCUPIED CASE - 1/83

FIGURE A-5. GRS BALANCING REACTOR ROTOR TYPE SINGLE RAIL SIGNAL SYSTEM

GRS Balancing Reactor Vane Type Single Rail Signaling Circuit

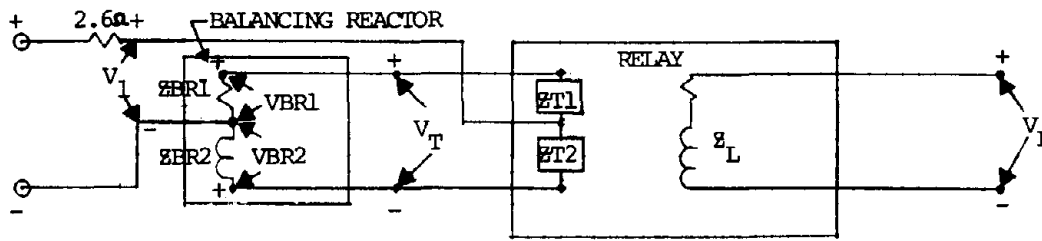

FIGURE A-6a. RECEIVING END CIRCUIT

normal Operating Values (Without Test Apparatus)

$V_L = 110 \angle 0^\circ$ (Reference)	$V_T = 1.00 \angle 68^\circ$ (.064 $\angle 102^\circ$ induced by V_L)
$I_L = .18 \angle -65^\circ$	$V_1 = .96 \angle 23^\circ$
$V_{RAILS} = 2.75 \angle 3^\circ$	$V_{BR1} = .480 \angle -5^\circ$ $Z_{BR1} = .780$
$I_{RAILS} = .72 \angle -7^\circ$	$V_{BR2} = 1.25 \angle 46^\circ$ $Z_{BR2} = .91 + j14.7$
$V_{2ND} = 5.25 \angle 0^\circ$	
$R_0 = 2.5$ Ohms	$R_1 = 15$ Ohms

Occupied Injection of 60 Hz Signal

V_L (Ref)	$V_T = V_{CONTROL}$	t_{bfc} , sec.	#Cycles
110	.91 $\angle 68^\circ$.22	13.0
110	1.00 $\angle 68^\circ$.18	10.5
110	1.09 $\angle 68^\circ$.16	9.5
120	.91 $\angle 68^\circ$.21	12.5
120	1.00 $\angle 68^\circ$.18	10.5
120	1.09 $\angle 68^\circ$.16	9.5

Unoccupied Interruption of 60 Hz signal

V_L (Ref)	$V_T = V_{CONTROL}$	t_{ifo} , sec.	#Cycles
100	.91 $\angle 68^\circ$.07	4.0
100	1.00 $\angle 68^\circ$.10	6.0
100	1.09 $\angle 68^\circ$.10	6.0
110	.91 $\angle 68^\circ$.12	7.0
110	1.00 $\angle 68^\circ$.13	7.5
110	1.09 $\angle 68^\circ$.13	7.5

Signaling Equipment

- Vane Relay - Type 'B', Size 2, Class V, DR No. 56005-100, S.N. 2557, Volts Local 110/55, Volts Track 2.0/1.0, Pos 2, Phase 2, Cycles 60.
- Track Transformer - G.R.S. DR No. 54940-5, GR4, S.N. 53860, Type 11, Size 1, Cycles 60, KVA .300.
- Balancing Impedance - G.R.S. DR No. 42960-1, S.N. M77030

- - CLOSED TO OPENED
- × - OPENED TO CLOSED
- - AFFECTS OF HYSTERESIS MINIMIZED

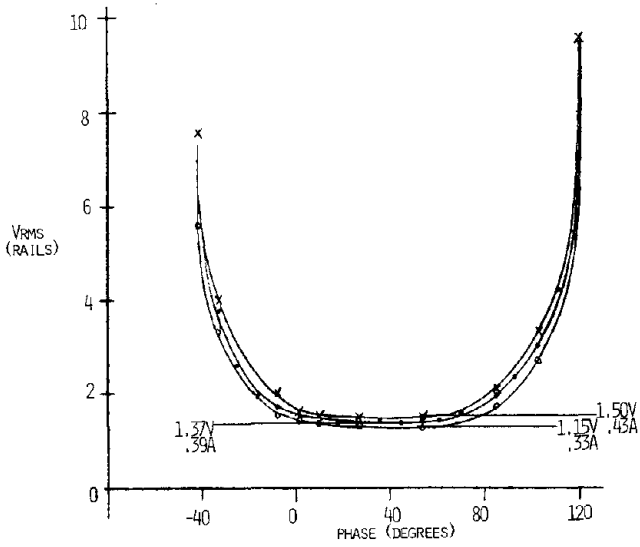

b. STATIC PHASE SHIFT OF 60 Hz ACROSS RAILS - 1/83

- - $V_{LOCAL}=110$ VRMS (REF)
 $V_{RAILS}=2.75 / 177^\circ$
- - $V_{LOCAL}=100$ VRMS (REF)
 $V_{RAILS}=2.50 / 177^\circ$

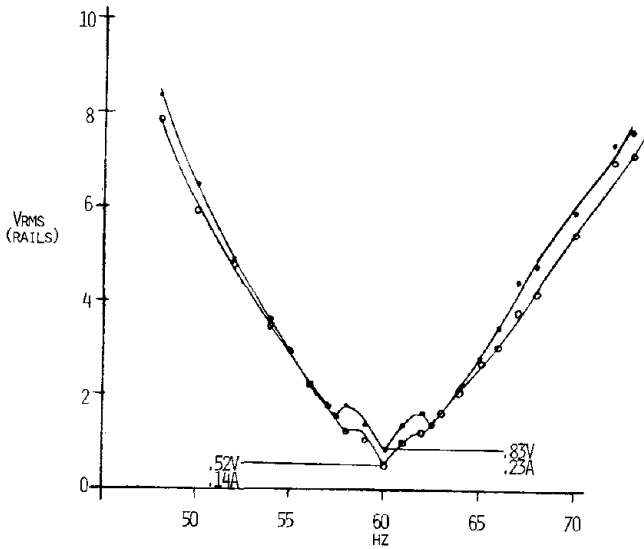

d. INTERFERING VOLTAGE ACROSS RAILS FOR UNOCCUPIED CASE - 1/83

- - $V_{LOCAL}=110$
- - $V_{LOCAL}=100$

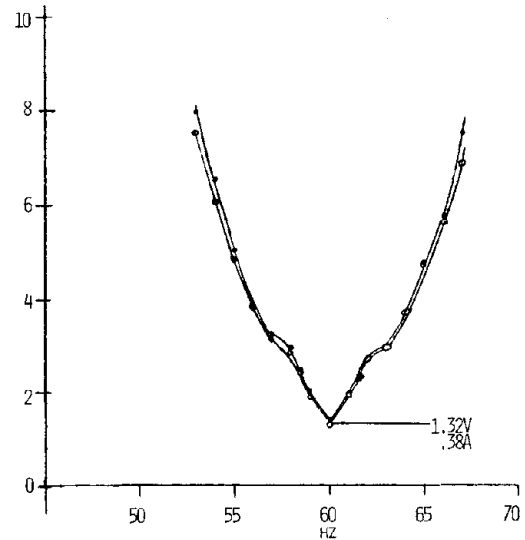

c. INTERFERING VOLTAGE ACROSS RAILS FOR OCCUPIED CASE - 1/83

FIGURE A-6. GRS BALANCING REACTOR VANE TYPE SINGLE RAIL SIGNAL SYSTEM

US&S Matching Transformer Single Rail Type Signaling Circuit

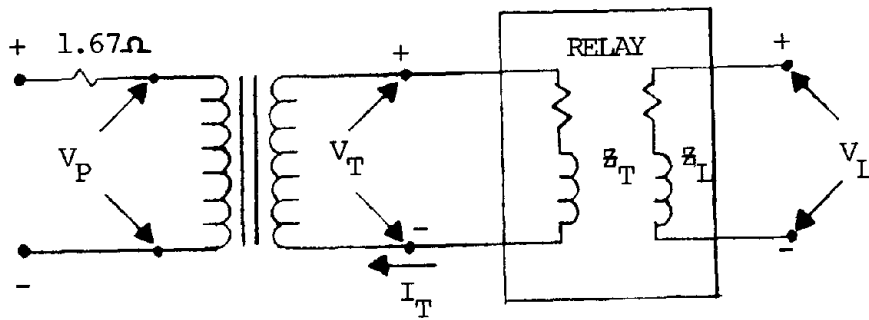

FIGURE A-7a. RECEIVING END CIRCUIT

Normal Operating Values (Without Test Apparatus)

$$\begin{aligned}
 V_L &= 114 \angle 0^\circ \text{ (Reference)} & V_T &= 5.1 \angle 63^\circ \text{ (.29} \angle -28^\circ \text{ Induced by } V_L) \\
 I_L &= .18 \angle -68^\circ & I_T &= .082 \angle -7^\circ \text{ (} Z_T = 21 + j59) \\
 V_{2ND} &= 4.27 \angle 0^\circ & V_P &= 1.20 \angle 57^\circ \\
 V_{RAILS} &= 3.45 \angle 3^\circ & R_0 &= 1 \text{ ohm} \\
 I_{RAILS} &= .58 \angle -14^\circ & R_1 &= \text{omitted}
 \end{aligned}$$

Occupied Injection of 60 Hz Signal

V_L (Ref)	$V_T = V_{CONTROL}$	t_{bfc} , sec.	#Cycles
104	$4.20 \angle 63^\circ$.25	14.7
104	$4.65 \angle 63^\circ$.20	12.0
104	$5.00 \angle 63^\circ$.18	10.8
114	$4.20 \angle 63^\circ$.22	13.2
114	$4.65 \angle 63^\circ$.18	10.8
114	$5.00 \angle 63^\circ$.16	9.6

Unoccupied Interruption of 60 Hz signal

V_L (Ref)	$V_T = V_{CONTROL}$	t_{ifo} , sec.	#Cycles
114	$4.20 \angle 63^\circ$.085	5.0
114	$4.65 \angle 63^\circ$.087	5.2
114	$5.00 \angle 63^\circ$.092	5.5
124	$4.20 \angle 63^\circ$.092	5.5
124	$4.65 \angle 63^\circ$.096	5.8
124	$5.00 \angle 63^\circ$.100	6.0

Signaling Equipment

1. Vane Relay - WABCO style PTV-42, UN385888-001, Spec 5270, S.N. A64872, Index-SH, Volts 115, Cycles-60
2. Track Transformer - WABCO style W-400, 60/100 Hz, VA360, UN451428-0101
3. Matching Transformer - WABCO, Volts 1-5, UN385860, V.A. 0.6, S.N 2481249

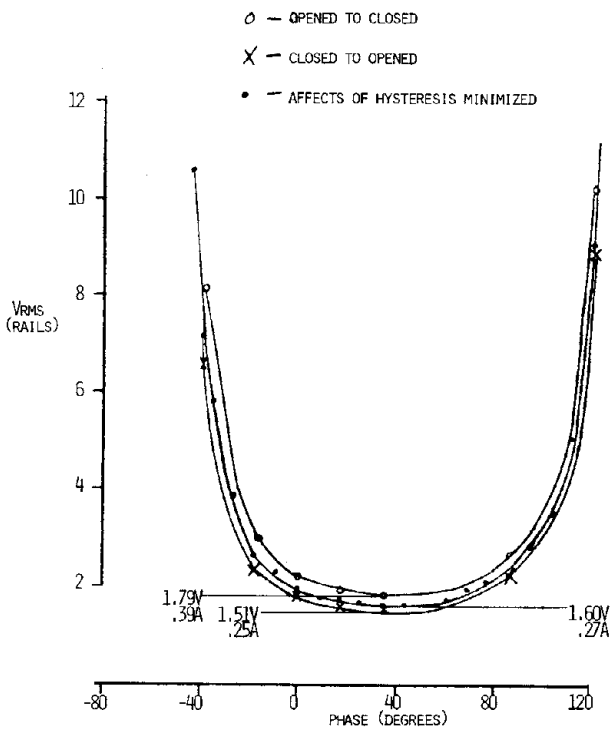

b. STATIC PHASE SHIFT OF 60 Hz ACROSS RAILS - 11/82

- - V LOCAL = 114 VRMS; V CONTROL = 4.65$^{\circ}$63$^{\circ}$
- - V LOCAL = 104 VRMS; V CONTROL = 4.20$^{\circ}$63$^{\circ}$
- X - V LOCAL = 114 VRMS; V CONTROL = 5.1$^{\circ}$63$^{\circ}$

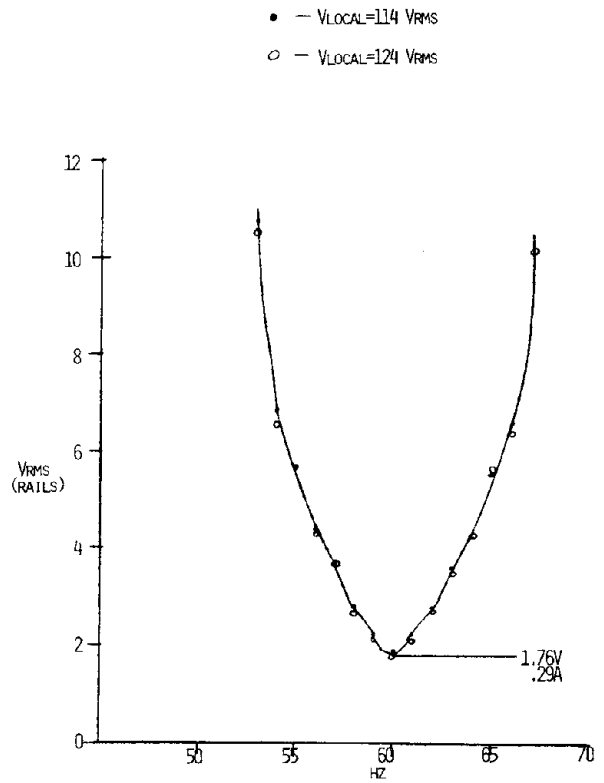

c. INTERFERING VOLTAGE ACROSS RAILS FOR OCCUPIED CASE - 11/82

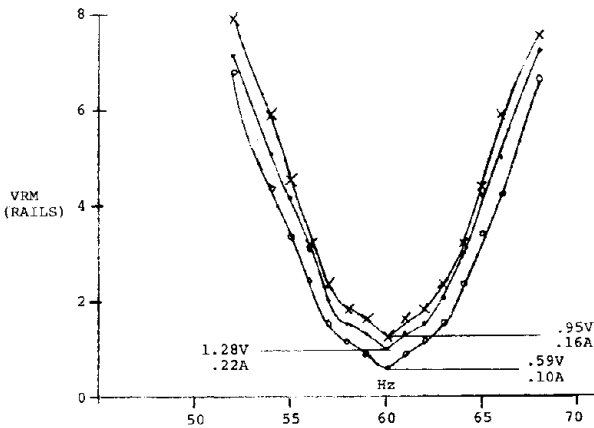

d. INTERFERING VOLTAGE ACROSS RAILS FOR UNOCCUPIED CASE - 11/82

FIGURE A-7. US&S MATCHING TRANSFORMER SINGLE RAIL SIGNAL SYSTEM

Retest of US&S Matching Transformer Type Signaling Circuit

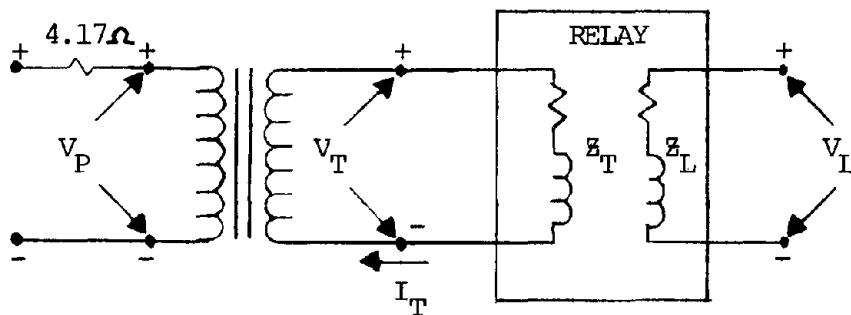

FIGURE A-8a. RECEIVING END CIRCUIT

Normal Operating Values (Without Test Apparatus)

$V_L = 114 \angle 0^\circ$ (Reference) $V_T = 4.4 \angle 59^\circ$ (.29 $\angle -28^\circ$ induced by V_L)
 $I_L = .18 \angle -68^\circ$ $I_T = .068 \angle -12^\circ$ ($Z_T = 21 + j61$)
 $V_{RAILS} = 2.55 \angle 3^\circ$ $V_p = 1.05 \angle 43^\circ$
 $I_{RAILS} = .48 \angle -20^\circ$
 $V_{2ND} = 3.1 \angle 0^\circ$
 $R_0 = .75$ Ohms R_1 omitted

Occupied Injection of 60 Hz Signal

V_L (Ref)	$V_T = V_{CONTROL}$	$t_{bfc}, \text{sec.}$	#Cycles
114	$3.99 \angle 59^\circ$.23	14.0
114	$4.37 \angle 59^\circ$.20	12.0
114	$4.75 \angle 59^\circ$.10	10.5
124	$3.99 \angle 59^\circ$.23	13.5
124	$4.37 \angle 59^\circ$.19	11.5
124	$4.75 \angle 59^\circ$.17	10.0

Unoccupied Interruption of 60 Hz signal

V_L (Ref)	$V_T = V_{CONTROL}$	$t_{ifo}, \text{sec.}$	#Cycles
104	$3.99 \angle 59^\circ$.033	2.0
104	$4.37 \angle 59^\circ$.067	4.0
104	$4.75 \angle 59^\circ$.067	4.0
114	$3.99 \angle 59^\circ$.072	4.3
114	$4.37 \angle 59^\circ$.078	4.7
114	$4.75 \angle 59^\circ$.083	5.0

signaling Equipment

1. Vane Relay - WABCO, UN385888-001, S.N. A64872, Index-SH, Volts 115, Cycles-60, Spec 5270.
2. Track Transformer - WABCO, Style W-400, 60/100 Hz, V.A. 360, UN451428-0101
3. Matching Transformer - WABCO, Volts 1-5, UN385860, V.A. 0.6, S.N. 2481249.

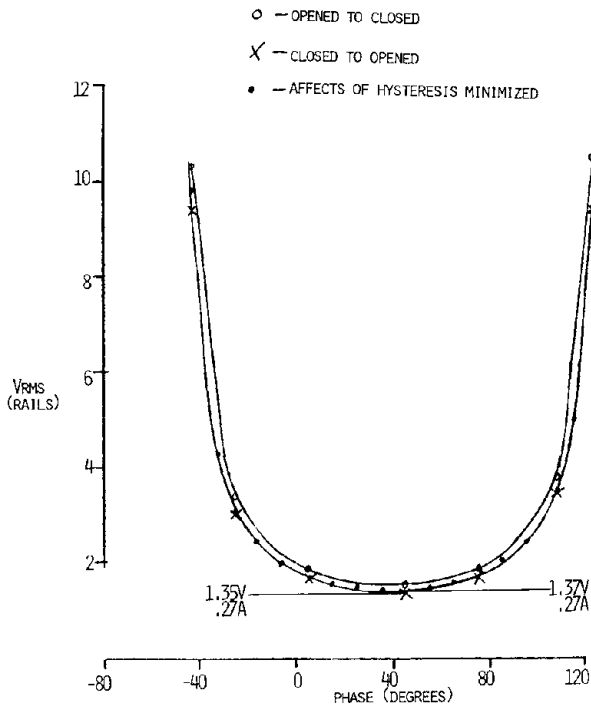

b. STATIC PHASE SHIFT OF 60 Hz ACROSS RAILS - 2/83 (RETEST)

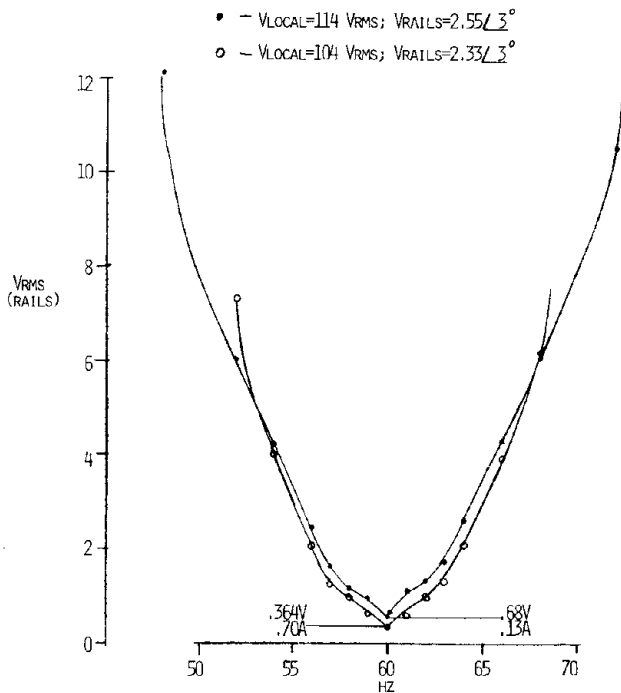

d. INTERFERING VOLTAGE ACROSS RAILS FOR UNOCCUPIED CASE - 2/83 (RETEST)

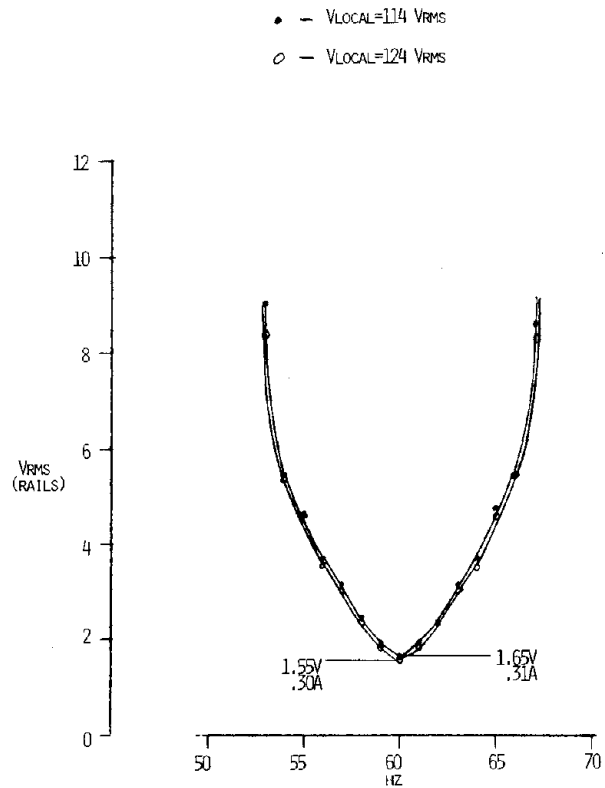

c. INTERFERING VOLTAGE ACROSS RAILS FOR OCCUPIED CASE - 2/83 (RETEST)

FIGURE A-8. US&S MATCHING TRANSFORMER SINGLE RAIL SIGNAL SYSTEM

US&S Matching Transformer Type Signaling Circuit Using PV-250 Relay

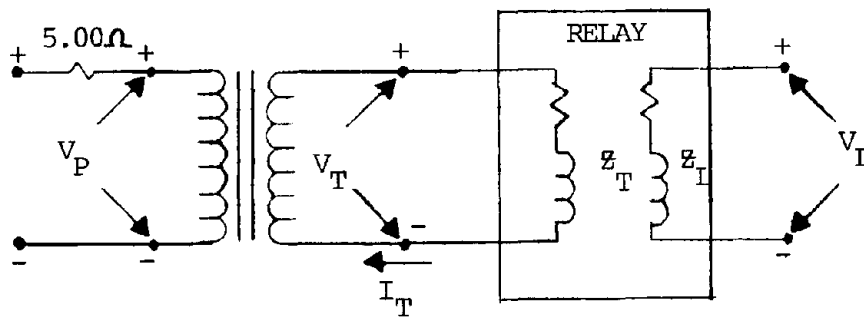

FIGURE A-9a. RECEIVING END CIRCUIT

Normal Operating Values (Without Test Apparatus)

$V_L = 114 \angle 0^\circ$ (Reference) $V_T = 5.0 \angle 60.5^\circ$ (.16 $\angle -8.5^\circ$ Induced by V_L)
 $I_L = .18 \angle -70^\circ$ $I_T = .076 \angle -5.5^\circ$ ($Z_T = 27 + j60$)
 $V_{RAILS} = 3.47 \angle 4^\circ$ $V_p = 1.2 \angle 45^\circ$
 $I_{RAILS} = .57 \angle -15^\circ$
 $V_{2ND} = 4.29 \angle 0^\circ$
 $R_0 = 1.5 \text{ Ohms}$ R_1 omitted

Occupied Injection of 60 Hz Signal

V_L (Ref)	$V_T = V_{CONTROL}$	$t_{bfc}, \text{sec.}$	#Cycles
114	$4.60 \angle 60.5^\circ$.23	13.5
114	$5.00 \angle 60.5^\circ$.19	11.5
114	$5.44 \angle 60.5^\circ$.17	10.0
124	$4.60 \angle 60.5^\circ$.21	12.5
124	$5.00 \angle 60.5^\circ$.18	10.5
124	$5.44 \angle 60.5^\circ$.16	9.5

Unoccupied Interruption of 60 Hz signal

V_L (Ref)	$V_T = V_{CONTROL}$	$t_{ifo}, \text{sec.}$	#Cycles
104	$4.60 \angle 60.5^\circ$.06	3.7
104	$5.00 \angle 60.5^\circ$.06	3.7
104	$5.44 \angle 60.5^\circ$.06	3.7
114	$4.60 \angle 60.5^\circ$.07	4.0
114	$5.00 \angle 60.5^\circ$.07	4.0
114	$5.44 \angle 60.5^\circ$.07	4.0

Signaling Equipment

1. Vane Relay - WABCO style PV250, UN342555-809, S.N. 2381820, Volts 115, Cycles-60.
2. Track Transformer - WABCO style W-400, 60/100 Hz, VA360, UN451428-0101
3. Matching Transformer - WABCO, Volts 1-5, UN385860, V.A. 0.6, S.N 2481249

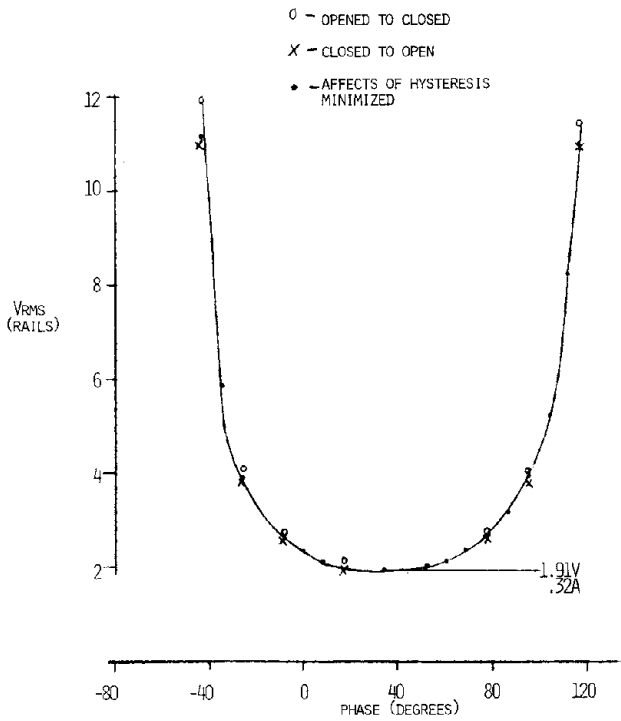

b. STATIC PHASE SHIFT OF 60 HZ
 ACROSS RAILS USING PV-250
 HIGH IMPEDANCE RELAY - 12/82

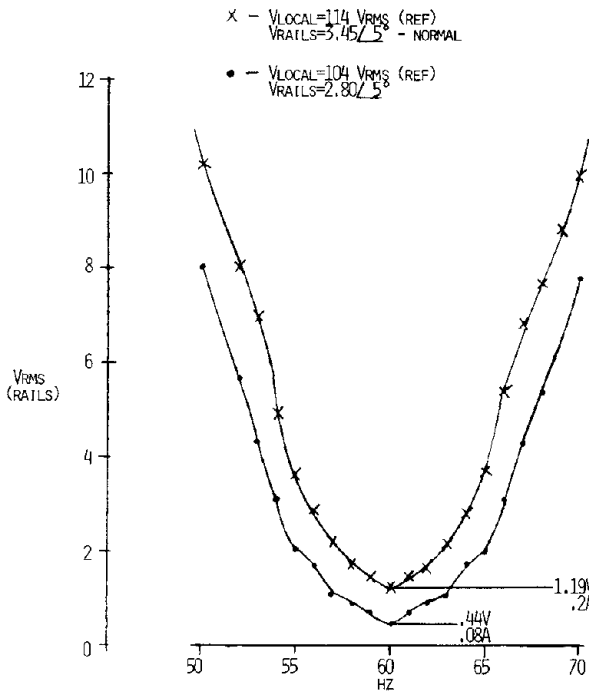

d. INTERFERING VOLTAGE ACROSS RAILS
 FOR UNOCCUPIED CASE USING PV-250
 HIGH IMPEDANCE RELAY - 12/82

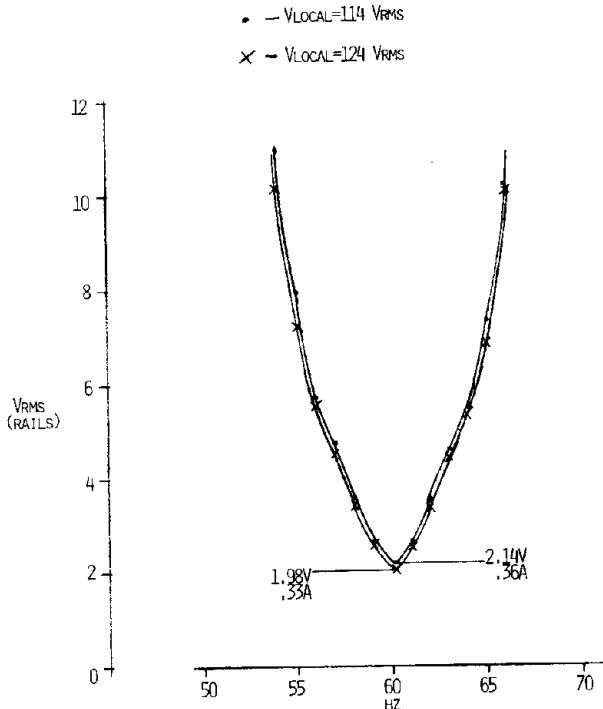

c. INTERFERING VOLTAGE ACROSS RAILS
 FOR OCCUPIED CASE USING PV-250
 HIGH IMPEDANCE RELAY - 12/82

FIGURE A-9. US&S MATCHING TRANSFORMER SINGLE RAIL SIGNAL SYSTEM

GRS Matching Transformer Type Signaling Circuit

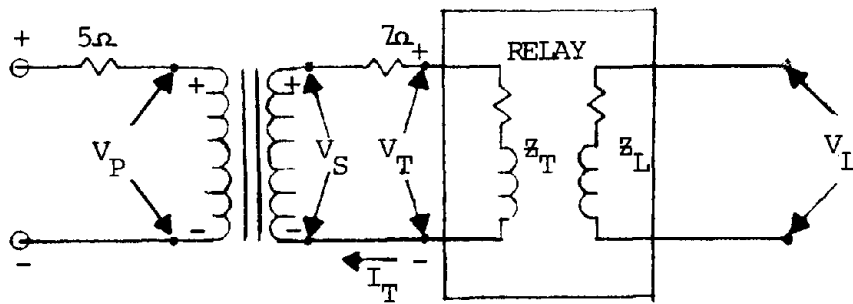

FIGURE A-10a. RECEIVING END CIRCUIT

Normal Operating Values (Without Test Apparatus)

$V_L = 110 \angle 0^\circ$ (Reference)	$V_T = 3.25 \angle 56^\circ$
$I_L = .176 \angle -65^\circ$	$I_T = .095 \angle -13^\circ$ ($Z_T = 12.5 + j32.0$)
$V_{RAILS} = 2.90 \angle 0^\circ$	$V_P = .95 \angle 43^\circ$
$I_{RAILS} = .43 \angle -12^\circ$	$V_S = 3.5 \angle 48^\circ$
$V_{2ND} = 5.00 \angle 0^\circ$	
$R_0 = 1.5$ Ohms	$R_1 = 3$ Ohms

Occupied Injection of 60 Hz Signal

V_L (Ref)	$V_T = V_{CONTROL}$	t_{bfc} , sec.	#Cycles
110	$3.25 \angle 56^\circ$.30	18.0
110	$3.55 \angle 56^\circ$.28	16.5
110	$3.25 \angle 56^\circ$.26	15.5
120	$3.55 \angle 56^\circ$.24	14.5

Unoccupied Interruption of 60 Hz signal

V_L (Ref)	$V_T = V_{CONTROL}$	t_{ifo} , sec.	#Cycles
100	$3.25 \angle 56^\circ$.12	7.2
100	$3.55 \angle 56^\circ$.11	6.5
100	$3.25 \angle 56^\circ$.13	7.5
110	$3.55 \angle 56^\circ$.12	7.0

Signaling Equipment

1. Vane Relay - G.R.S. DR NO. 56005-100, GR18, S.N.6151.
NYCTA Tag: Local 110V, P.U. 1.75V, W1.7V.
Set between 2.7 and 3.0 volts.
2. Track Transformer - G.R.S. Type U, Size 1, D.R. No. 54940-5, S.N. 53860
3. Matching Transformer - G.R.S. Type U, Size 1, D.R. No. 54940-8,
S.N. C80132, GR3

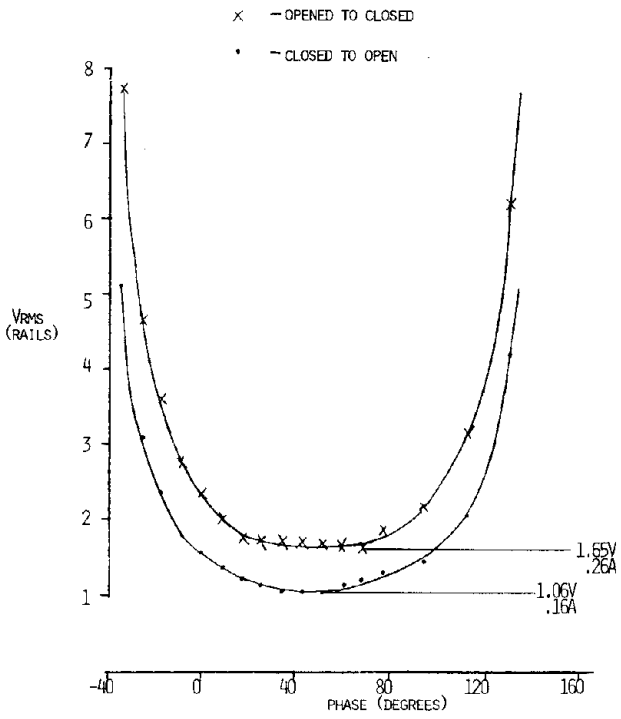

b. STATIC PHASE SHIFT OF 60 Hz ACROSS RAILS - 12/82

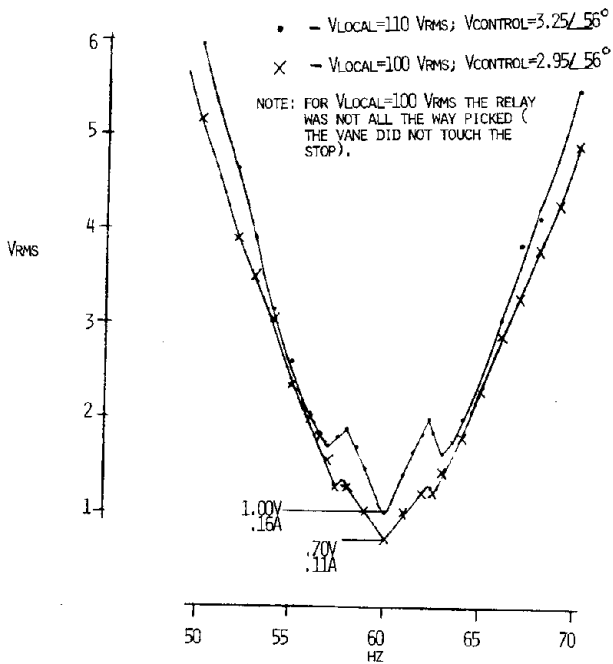

d. INTERFERING VOLTAGE ACROSS RAILS FOR UNOCCUPIED CASE - 12/82

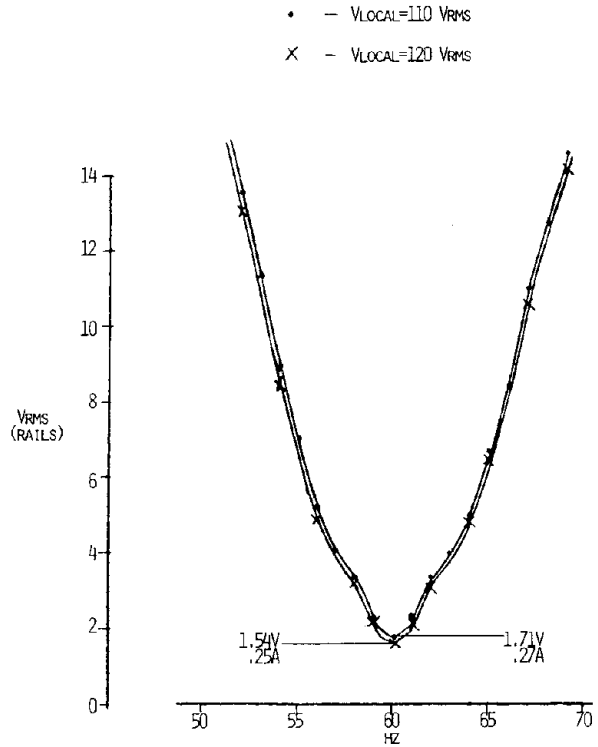

c. INTERFERING VOLTAGE ACROSS RAILS FOR OCCUPIED CASE - 12/82

FIGURE A-10. GRS MATCHING TRANSFORMER SINGLE RAIL SIGNAL SYSTEM

US&S Matching Transformer Double Rail Signaling
Circuit Using PV-250 Relay

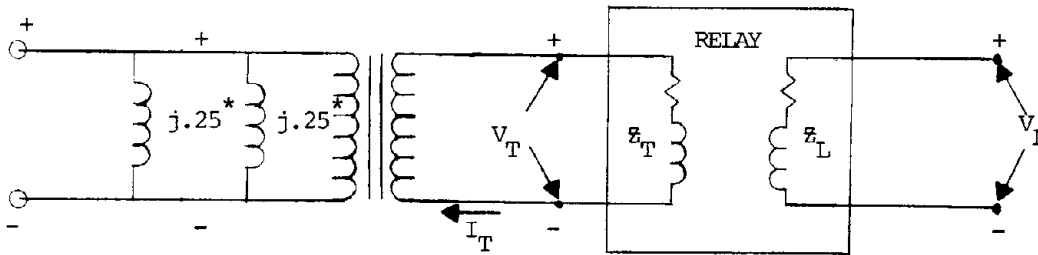

FIGURE A-11a. RECEIVING END CIRCUIT

Normal Operating Values (Without Test Apparatus)

$$\begin{aligned}
 V_L &= 114 \angle 0^\circ \text{ (Reference)} & V_T &= 4.0 \angle 97^\circ \text{ (.16} \angle -8.5^\circ \text{ Induced by } V_L) \\
 I_L &= .18 \angle -70^\circ & I_T &= .064 \angle 32^\circ \text{ (} Z_T = 26 + j57) \\
 V_{RAILS} &= .980 \angle 81^\circ \\
 I_{RAILS} &= .49 \angle 23^\circ \\
 V_{2ND} &= 6.24 \angle 0^\circ \text{ (Calculated - See explanation on next page)} \\
 R_0 &= .75 \text{ Ohms} & R_1 &= \text{omitted}
 \end{aligned}$$

Occupied Injection of 60 Hz Signal

V_L (Ref)	$V_T = V_{CONTROL}$	t_{bfc} , sec.	#Cycles
114	$3.65 \angle 97^\circ$.24	14.5
114	$4.00 \angle 97^\circ$.19	11.5
114	$4.35 \angle 97^\circ$.17	10.2
124	$3.65 \angle 97^\circ$.22	13.0
124	$4.00 \angle 97^\circ$.18	11.0
124	$4.35 \angle 97^\circ$.16	9.5

Unoccupied Interruption of 60 Hz signal

V_L (Ref)	$V_T = V_{CONTROL}$	t_{ifo} , sec.	#Cycles
104	$3.65 \angle 97^\circ$.050	3.0
104	$4.00 \angle 97^\circ$.055	3.3
104	$4.35 \angle 97^\circ$.058	3.5
114	$3.65 \angle 97^\circ$.055	3.3
114	$4.00 \angle 97^\circ$.058	3.5
114	$4.35 \angle 97^\circ$.062	3.7

signaling Equipment

1. Vane Relay - WABCO Style PV-250, UN342555-809, S.N. 2381820, Volts 115, Cycles 60.
2. Track Transformer - WABCO Style W-400, 60/100 Hz, V.A. 360, UN451428-0101
3. Matching Transformer - Volts 1-5, UN-385860, V.A. 0.6, S.N. 2481249

US&S Matching Transformer Double Rail Signaling
Circuit Using PV-250 Relay (Cont'd)

The impedance bonds of .25 ohms pure inductance shown in Figure A-11a were not actually in the circuit since the actual impedance bonds were too large to be shipped from New York. Therefore, the effects of having these inductances in the circuit on the relationship between V_{2ND} and V_{RAILS} were calculated.

This double rail circuit is identical to the US&S single rail matching transformer circuit using the PV-250 relay when looking into the matching transformer toward the relay. The voltage, V_p (Figure A-9a), was measured at $1.2 \angle 45^\circ$ and the current, I_{RAILS} (Figure A-9a), was measured at $.57 \angle -15^\circ$ A. Therefore, the impedance looking into the matching transformer is:

$$Z_1 = 1.05 + j1.82$$

Looking from the tracks at the feed end into this impedance in parallel with the two parallel .25 ohm inductances gives:

$$\begin{aligned} Z_2 &= Z_1 \times [(.25/2) \angle 90^\circ] / [Z_1 + j(.25/2)] \\ &= .119 \angle 88.4 = .003 + j.119 \end{aligned}$$

The impedance looking from V_{2ND} is .75 ohms in series with Z_2 :

$$Z_3 = .753 + j.119 = .762 \angle 8.98^\circ$$

Therefore, the relationship between V_{2ND} and V_{RAILS} is:

$$V_{RAILS} = (Z_2/Z_3) \times V_{2ND} = .156 \angle 80^\circ \times V_{2ND}$$

To determine V_{RAILS} , the phase was set at approximately 80° with the phase shifter and the KEPCO gain was adjusted so that when the track relay coil was suddenly energized the vane would pick up and lift the upper stop slightly before the stop slowly dropped down. The voltage, V_{RAILS} , required to do this was found to be .980 Vrms and V_{2ND} was calculated to be 6.24 Vrms. This voltage was located on a pair of taps on the secondary of the track transformer.

- o - CLOSED TO OPEN
- x - OPENED TO CLOSED
- - AFFECTS OF HYSTERESIS MINIMIZED

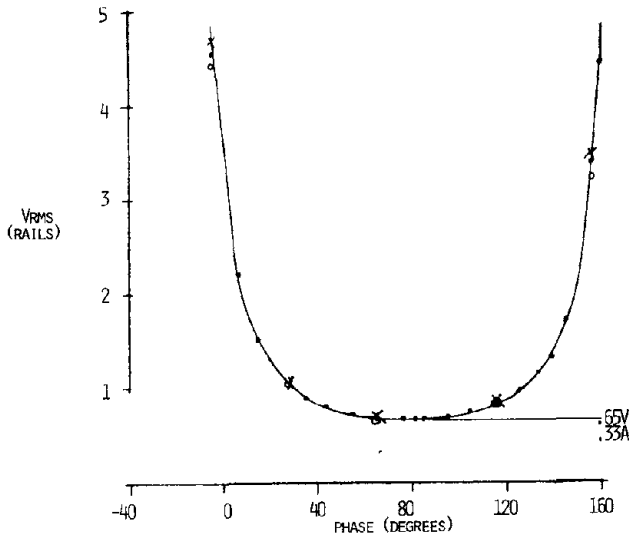

b. STATIC PHASE SHIFT OF 60 HZ ACROSS RAILS USING PV-250 HIGH IMPEDANCE RELAY - 1/83

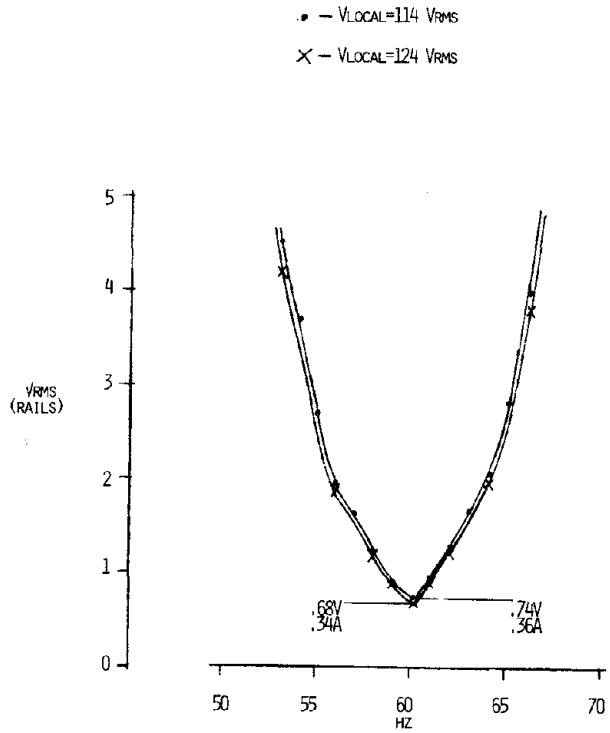

c. INTERFERING VOLTAGE ACROSS RAILS FOR OCCUPIED CASE USING PV-250 HIGH 250 IMPEDANCE RELAY -1/83

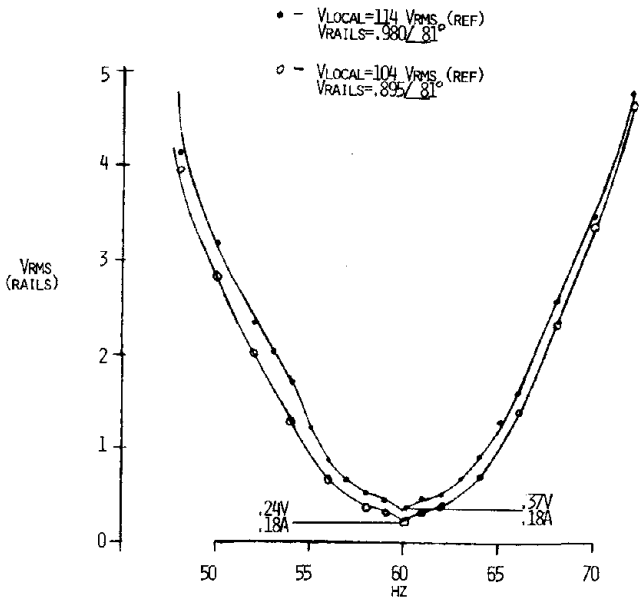

d. INTERFERING VOLTAGE ACROSS RAILS FOR UNOCCUPIED CASE USING PV-250 HIGH IMPEDANCE RELAY - 1/83

FIGURE A-11. US&S MATCHING TRANSFORMER DOUBLE RAIL SIGNAL SYSTEM

GRS Matching Transformer Double Rail Signaling Circuit

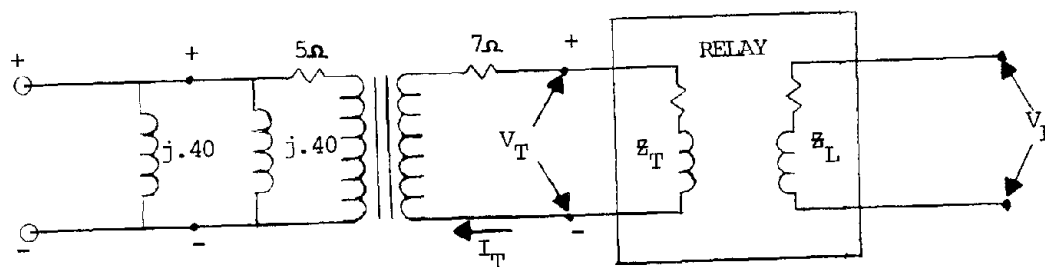

FIGURE A-12a. RECEIVING END CIRCUIT

Normal operating Values (Without Test Apparatus)

$$\begin{aligned}
 V_L &= 110 \angle 0^\circ \text{ (Reference)} & V_T &= 2.48 \angle 138^\circ \text{ (.39} \angle 89^\circ \text{ induced by } V_L) \\
 I_L &= .176 \angle -65^\circ & I_T &= .065 \angle 62^\circ \text{ (} Z_T = 9.3 + j37.1) \\
 V_{RAILS} &= 2.10 \angle 77^\circ \\
 I_{RAILS} &= .33 \angle 60^\circ \\
 V_{2ND} &= 16.3 \angle 0^\circ \text{ (Calculated - See explanation on next page)} \\
 R_0 &= 1.5 \text{ Ohms} & R_1 &= \text{omitted}
 \end{aligned}$$

Occupied Injection of 60 Hz Signal

V_L (Ref)	$V_T = V_{CONTROL}$	$t_{bfc}, \text{sec.}$	#Cycles
110	$1.91 \angle 77^\circ$.35	21.0
110	$2.10 \angle 77^\circ$.28	16.5
110	$2.29 \angle 77^\circ$.24	14.5
120	$1.91 \angle 77^\circ$.32	19.0
120	$2.10 \angle 77^\circ$.26	15.5
120	$2.29 \angle 77^\circ$.23	14.0

Unoccupied Interruption of 60 Hz signal

V_L (Ref)	$V_T = V_{CONTROL}$	$t_{ifo}, \text{sec.}$	#Cycles
100	$1.91 \angle 77^\circ$.05	3.0
100	$2.10 \angle 77^\circ$.11	6.5
100	$2.29 \angle 77^\circ$.13	7.5
110	$1.91 \angle 77^\circ$.11	6.3
110	$2.10 \angle 77^\circ$.11	6.5
110	$2.29 \angle 77^\circ$.12	7.0

Signaling Equipment

- Vane Relay - G.R.S., DR No. 56005-100, GR18, S.N: 6151, Local Volts 110, P.U. 1.75V, W1.7V, Set Between 2.7 and 3.0 volts
- Track Transformer - G.R.S. Type U, Size 1, Serial No. 53860, DR. No. 54940-5
- Matching Transformer - G.R.S. GR3, Type U, Size 1, DR No. 54940-8, Serial No. C80132

GRS Matching Transformer Double Rail Signaling Circuit (Cont.d)

The impedance bonds of .40 ohms pure inductance shown in Figure A-12a were not actually in the circuit since the actual impedance bonds were too large to be shipped from New York. Therefore, the effects of having these inductances in the circuit on the relationship between V_{2ND} and V_{RAILS} were calculated.

The impedance looking into the relay from where V_{RAILS} is measured is:

$$Z_1 = V_{RAILS}/I_{RAILS} = 6.4 + j1.88$$

The impedance looking from the tracks at the feed end towards the relay with the two impedance bonds across the tracks gives:

$$\begin{aligned} Z_2 &= Z_1 [(.40/2) \angle 90^\circ] / [Z_1 + j(.40/2)] \\ &= .006 + j.198 \end{aligned}$$

The impedance looking from V_{2ND} towards the receiving end is:

$$\begin{aligned} Z_3 &= 1.5 \times Z_2 / (1.5 + Z_2) \\ &= 1.52 + j.2 \end{aligned}$$

The relationship between V_{2ND} and V_{RAILS} is:

$$\begin{aligned} V_{2ND} &= (Z_2/Z_3) \times V_{RAILS} \\ &= 7.75 \angle -77^\circ \times V_{RAILS} \end{aligned}$$

V_{RAILS} was set at $2.10 \angle 77^\circ$ such that the vane of the relay struck the stop solidly. V_{2ND} was calculated to be $16.3 \angle 0^\circ$.

- — CLOSED TO OPENED
- X — OPENED TO CLOSED
- — AFFECTS OF HYSTERESIS MINIMIZED

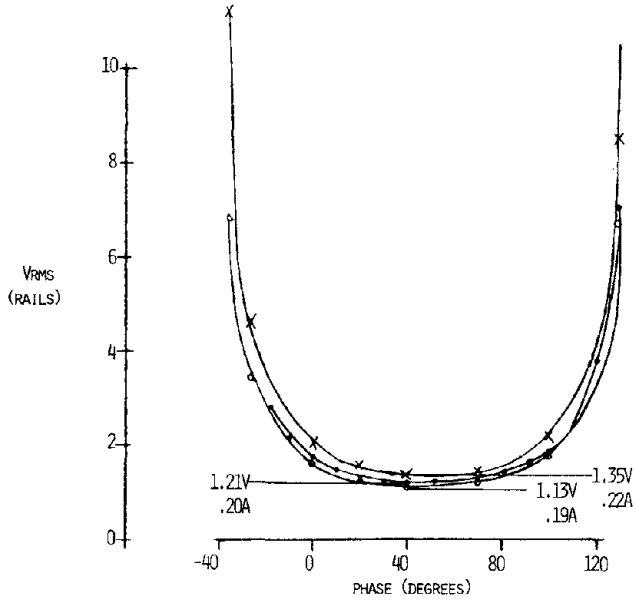

b. STATIC PHASE SHIFT OF 60 Hz ACROSS RAILS - 2/83

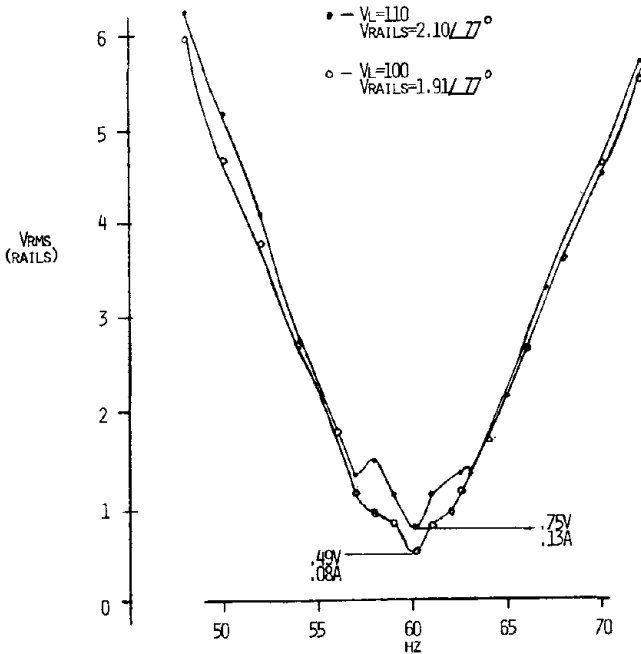

d. INTERFERING VOLTAGE ACROSS RAILS FOR UNOCCUPIED CASE - 2/83

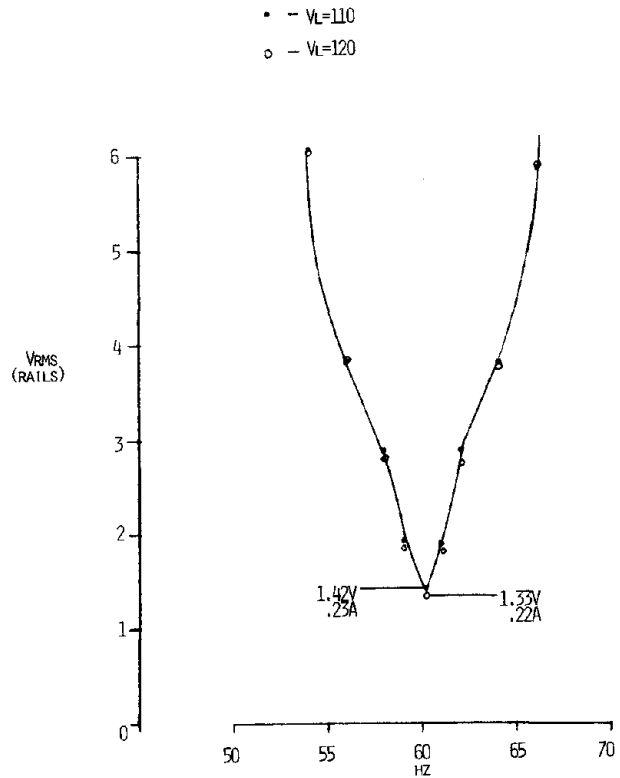

c. INTERFERING VOLTAGE ACROSS RAILS FOR OCCUPIED CASE - 2/83

FIGURE A-12. GPS MATCHING TRANSFORMER DOUBLE RAIL SIGNAL SYSTEM

GRS Capacitor Type Single Rail Signaling Circuit

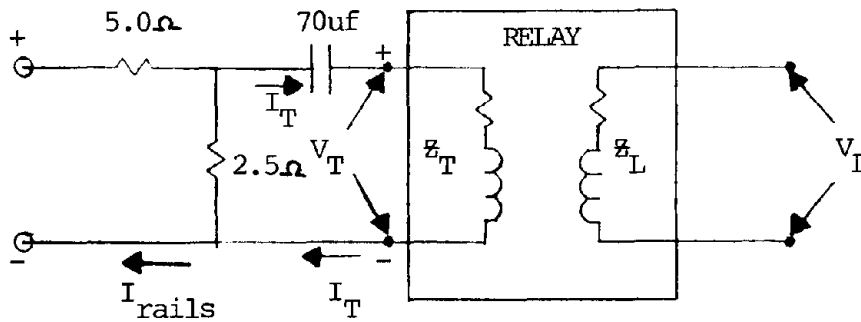

FIGURE A-13a. RECEIVING END CIRCUIT

Normal Operating Values (Without Test Apparatus)

$$V_L = 110 \angle 0^\circ \text{ (Reference)}$$

$$I_L = .176 \angle -65^\circ$$

$$V_{RAILS} = 4.05 \angle 8.5^\circ$$

$$I_{RAILS} = .58 \angle 8.5^\circ$$

$$R_0 = 1.5 \text{ Ohms}$$

$$V_T = 2.85 \angle 103^\circ \text{ (.4} \angle 69^\circ \text{ induced by } V_L)$$

$$I_T = .083 \angle 35^\circ \text{ (} Z_T = 12.6 + j32.0)$$

$$R_1 \text{ omitted}$$

Occupied Injection of 60 Hz Signal

V_L (Ref)	$V_T = V_{CONTROL}$	$t_{bfc}, \text{sec.}$	#Cycles
110	$3.00 \angle 101^\circ$.29	17.4
110	$2.85 \angle 101^\circ$.32	19.0
110	$2.70 \angle 101^\circ$.33	19.8
120	$3.27 \angle 101^\circ$.21	12.6
120	$3.11 \angle 101^\circ$.23	13.8
120	$2.95 \angle 101^\circ$.26	15.6

Unoccupied Interruption of 60 Hz signal

V_L (Ref)	$V_T = V_{CONTROL}$	$t_{ifo}, \text{sec.}$	#Cycles
110	$3.00 \angle 101^\circ$.140	8.3
110	$2.85 \angle 101^\circ$.137	8.2
110	$2.70 \angle 101^\circ$.134	8.2
100	$2.73 \angle 101^\circ$.120	7.2
100	$2.59 \angle 101^\circ$.120	7.2
100	$2.45 \angle 101^\circ$.120	7.2

Signaling Equipment

1. Track Transformer - G.R.S. Type U, Size 1, DR No. 54940-5, Serial No. 53861
2. Vane Relay - G.R.S., Local Volts 110, P.U. 1.75, W 1.7, Track Voltage set between 2.7 and 3.0 volts, DR. No. 56005-100, GR18, Serial No. 6151.
3. Capacitors - (2 in parallel), Sprague ECCOL No. PCBS, 35 uF/370 VAC, 60 Hz, D5000 AFC Protected, 520p356x6370d55p4x, Made in U.S. 8018.

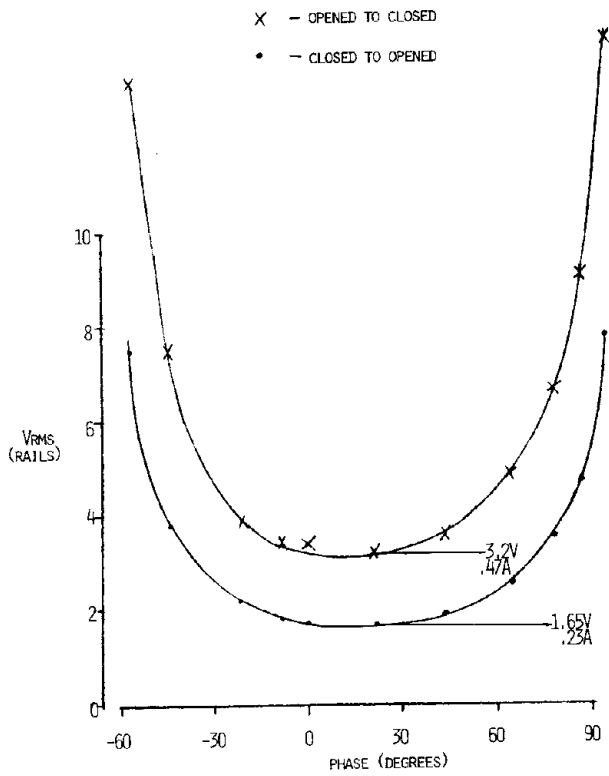

b. STATIC PHASE SHIFT OF 60 Hz ACROSS RAILS - 11/82

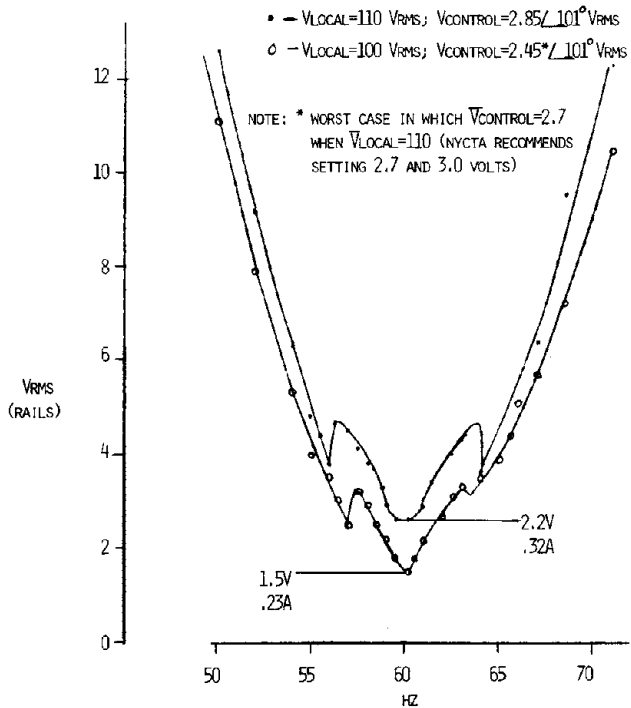

d. INTERFERING VOLTAGE ACROSS RAILS FOR UNOCCUPIED CASE - 11/82

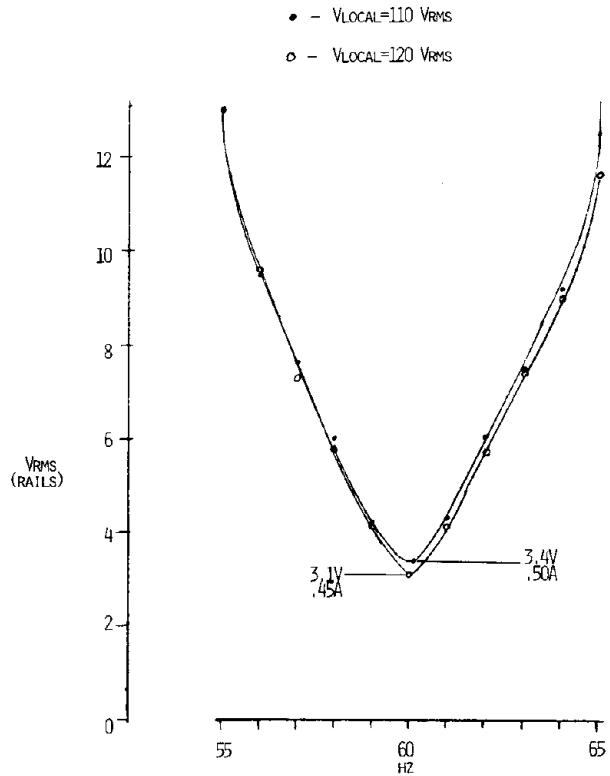

c. INTERFERING VOLTAGE ACROSS RAILS FOR OCCUPIED CASE - 11/82

FIGURE A-13. GRS CAPACITOR TYPE SINGLE RAIL SIGNAL SYSTEM

US&S Capacitor Type Single Rail Signaling Circuit

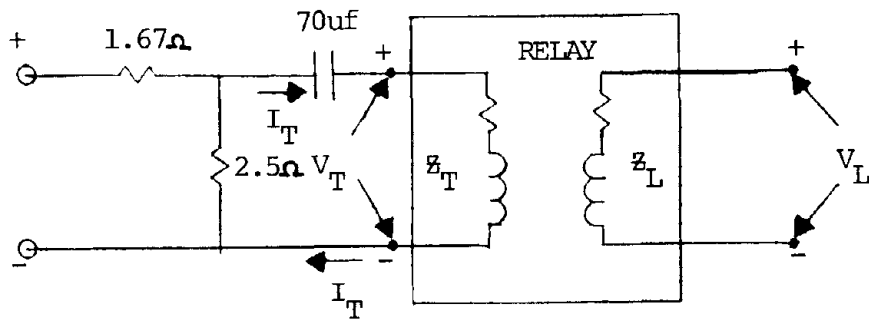

FIGURE A-14a. RECEIVING END CIRCUIT

Normal Operating Values (Without Test Apparatus)

$$\begin{aligned}
 V_L &= 114 \angle 0^\circ \text{ (Reference)} & V_T &= 3.10 \angle 78^\circ \text{ (.16} \angle -6^\circ \text{ induced by } V_L) \\
 I_L &= .165 \angle -67^\circ & I_T &= .079 \angle 7^\circ \text{ (} Z_T = 13 + j37) \\
 V_{RAILS} &= 1.90 \angle 0^\circ \\
 I_{RAILS} &= .53 \angle -4^\circ \\
 V_{2NDU} &= 2.34 \angle -4^\circ \\
 R_0 &= .75 \text{ Ohms} & R_1 &= \text{omitted}
 \end{aligned}$$

Occupied Injection of 60 Hz Signal

V_L (Ref)	$V_T = V_{CONTROL}$	t_{bfc} , sec.	#Cycles
114	$2.83 \angle 78^\circ$.25	15
114	$3.10 \angle 78^\circ$.20	12
114	$3.40 \angle 78^\circ$.18	11
124	$2.83 \angle 78^\circ$.22	13
124	$3.10 \angle 78^\circ$.18	11
124	$3.40 \angle 78^\circ$.16	10

Unoccupied Interruption of 60 Hz signal

V_L (Ref)	$V_T = V_{CONTROL}$	t_{ifo} , sec.	#Cycles
104	$2.83 \angle 78^\circ$.050	3.0
104	$3.10 \angle 78^\circ$.055	3.5
104	$3.40 \angle 78^\circ$.075	4.5
114	$2.83 \angle 78^\circ$.050	3.0
114	$3.10 \angle 78^\circ$.070	4.2
114	$3.40 \angle 78^\circ$.105	6.3

Signaling Equipment

1. Vane Relay - WABCO Model PV-250, 2F2B, 60 Hz, UN-342555-811, S.N. L575129, Cycles 60.
2. Track Transformer - WABCO Style W-400, 60/100 Hz, V.A. 360, UN-451428-0101
3. Capacitors - (2 in parallel) Sprague ECCOL No. PCBS, 35 uf/370 VAC, 60 Hz, D5000, AFC Protected, 520P356X6370D55P4X

- × - OPENED TO CLOSED
- - CLOSED TO OPENED
- - AFFECTS OF HYSTERESIS MINIMIZED

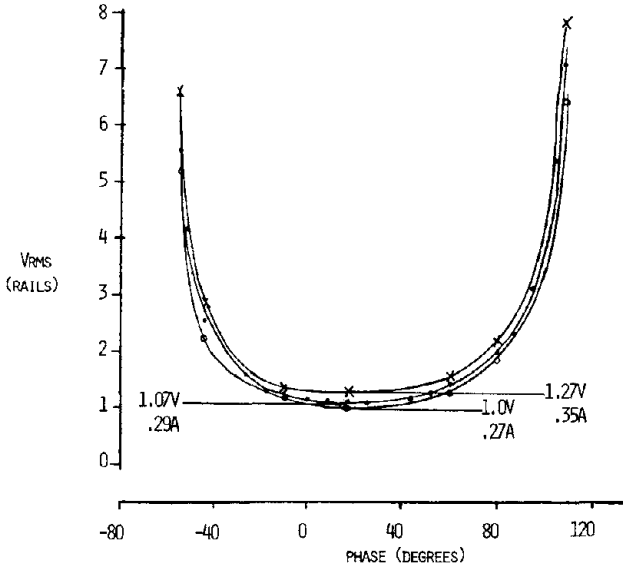

b. STATIC PHASE SHIFT OF 60 Hz ACROSS RAILS - 11/82

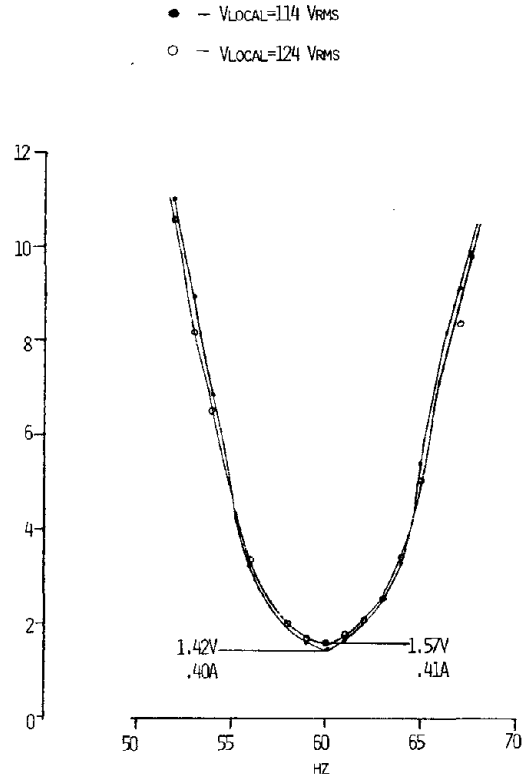

c. INTERFERING VOLTAGE ACROSS RAILS FOR OCCUPIED CASE - 11/82

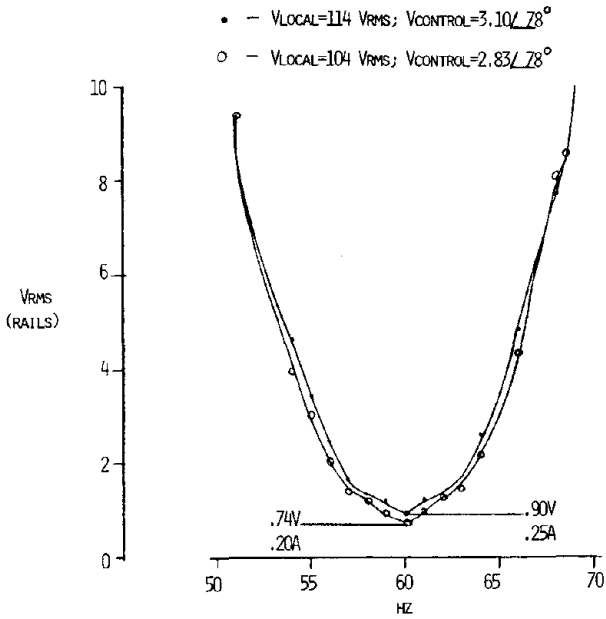

d. INTERFERING VOLTAGE ACROSS RAILS FOR UNOCCUPIED CASE - 11/82

FIGURE A-14. US&S CAPACITOR TYPE SINGLE RAIL SIGNAL SYSTEM

US&S Shielding Reactor Single Rail Signaling Circuit

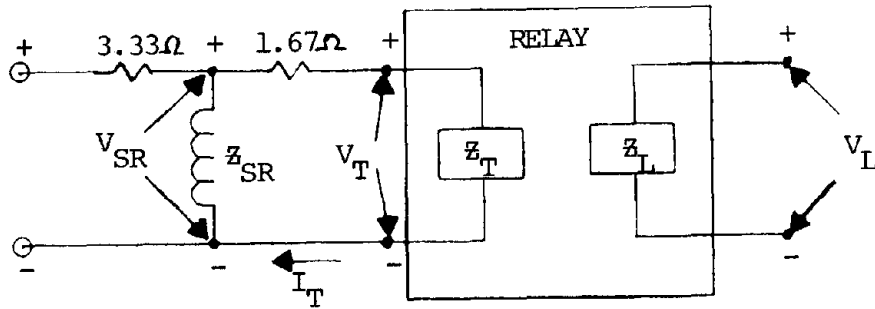

FIGURE A-15a. RECEIVING END CIRCUIT

normal Operating Values (Without Test Apparatus)

$V_L = 110 \angle 0^\circ$ (Reference)	$V_T = 1.50 \angle 65^\circ$ (.21 $\angle 65^\circ$ induced by V_L)
$I_L = .43 \angle -64^\circ$	$I_T = .29 \angle -2^\circ$ ($Z_T = 5.2 \angle 67^\circ$)
$V_{RAILS} = 3.05 \angle 13^\circ$	$V_{SR} = 1.74 \angle 51^\circ$
$I_{RAILS} = .63 \angle -20^\circ$	$I_{SR} = .34 \angle -35^\circ$ ($Z_{SR} = 5.07 \angle 86^\circ$)
$V_{2ND} = 4.92 \angle 0^\circ$	
$R_0 = 3.33$ Ohms	R_1 omitted

occupied Injection of 60 Hz Signal

V_L (Ref)	$V_T = V_{CONTROL}$	$t_{bfc}, \text{sec.}$	#Cycles
110	$1.36 \angle 65^\circ$.16	9.5
110	$1.50 \angle 65^\circ$.15	9.0
110	$1.64 \angle 65^\circ$.12	7.0
120	$1.36 \angle 65^\circ$.13	8.0
120	$1.50 \angle 65^\circ$.12	7.0
120	$1.64 \angle 65^\circ$.10	6.0

unoccupied Interruption of 60 Hz signal

V_L (Ref)	$V_T = V_{CONTROL}$	$t_{ifo}, \text{sec.}$	#Cycles
100	$1.36 \angle 65^\circ$.02	1.0
100	$1.50 \angle 65^\circ$.05	3.0
100	$1.64 \angle 65^\circ$.06	3.5
110	$1.36 \angle 65^\circ$.04	2.5
110	$1.50 \angle 65^\circ$.07	4.3
110	$1.64 \angle 65^\circ$.07	4.3

Signaling Equipment

1. Vane Relay - U.S. & S. Model 15, Style T2V16, 2 Position, Local Volts 110V, .4 Amps, 60 Cycles, S.N. C7936
2. Shielding Reactor - U.S. & S. Style VG-12, UN-297585, S.N. 0283274, Airgap .042 Inches, Impedance at 60 Cycles 6.0 Ohms, Max Current = 20 Amps, Resistance = .063
3. Track Transformer - U.S. & S. Style W400, 360 V.A., 60/100 Hz, UN451428-0101

- -- OPENED TO CLOSED
- × -- CLOSED TO OPEN
- -- EFFECTS OF HYSTERESIS MINIMIZED

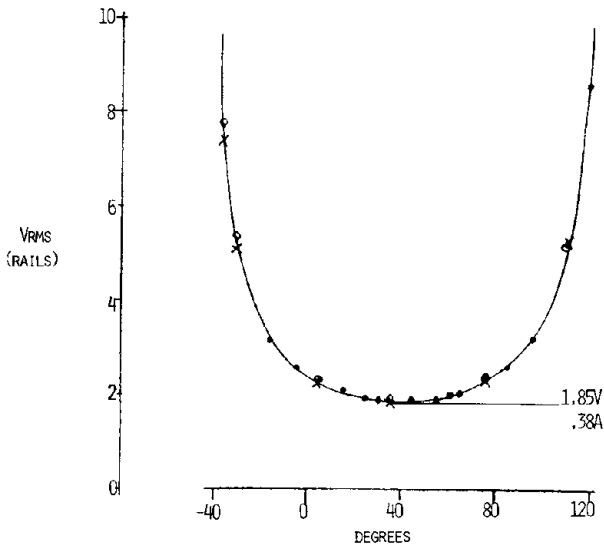

b. STATIC PHASE SHIFT OF 60 Hz ACROSS RAILS - 3/83

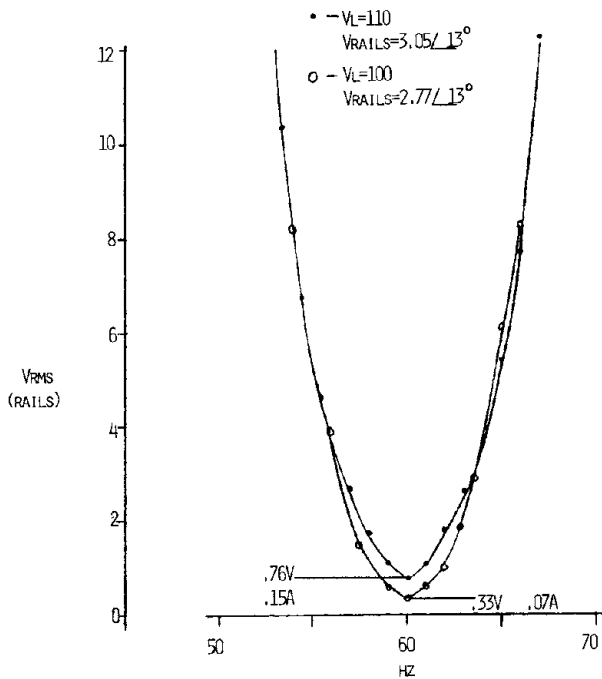

d. INTERFERING VOLTAGE ACROSS RAILS FOR UNOCCUPIED CASE - 3/83

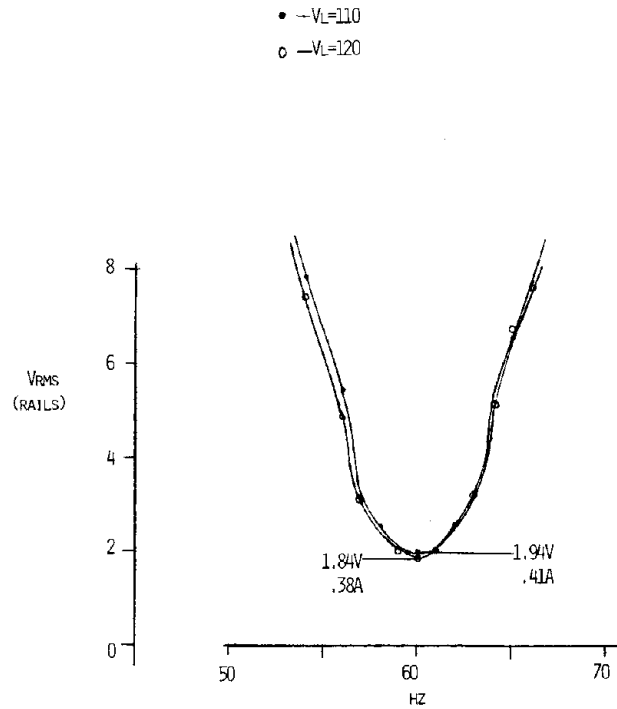

c. INTERFERING VOLTAGE ACROSS RAILS FOR OCCUPIED CASE - 3/83

FIGURE A-15. US&S SHIELDING REACTOR SINGLE RAIL 60 Hz SIGNAL SYSTEM

APPENDIX B
DATA FROM FIELD TESTS ON NYCTA TRACK CIRCUITS

<u>FIGURE</u>	<u>Description</u>	<u>Page</u>
B-1	General test setup	B-2
B-2	Track circuit no. F3A-834 components	B-3
B-3	Track circuit no. F3A-834 interfering voltage across leads from rails at receiving end for unoccupied case	B-4
B-4	Track circuit no. F3A-834 interfering voltage across leads from rails at receiving end for occupied case	B-5
B-5	Track circuit no. F3A-834 interfering voltage across leads to rails at feed end for both occupied and unoccupied cases	B-6
B-6	Track circuit no. E4-744 components	B-7
B-7	Track circuit no. E4-744 interfering voltage across leads from rails at receiving end for both occupied and unoccupied cases	B-8
B-8	Track circuit no. D-1492 components	B-9
B-9	Track circuit no. D-1492 interfering voltage across leads to rails at feed end for both occupied and unoccupied cases	B-10
B-10	Track circuit no. D-1492 interfering voltage across leads from rails at receiving end for both occupied and unoccupied cases	B-11

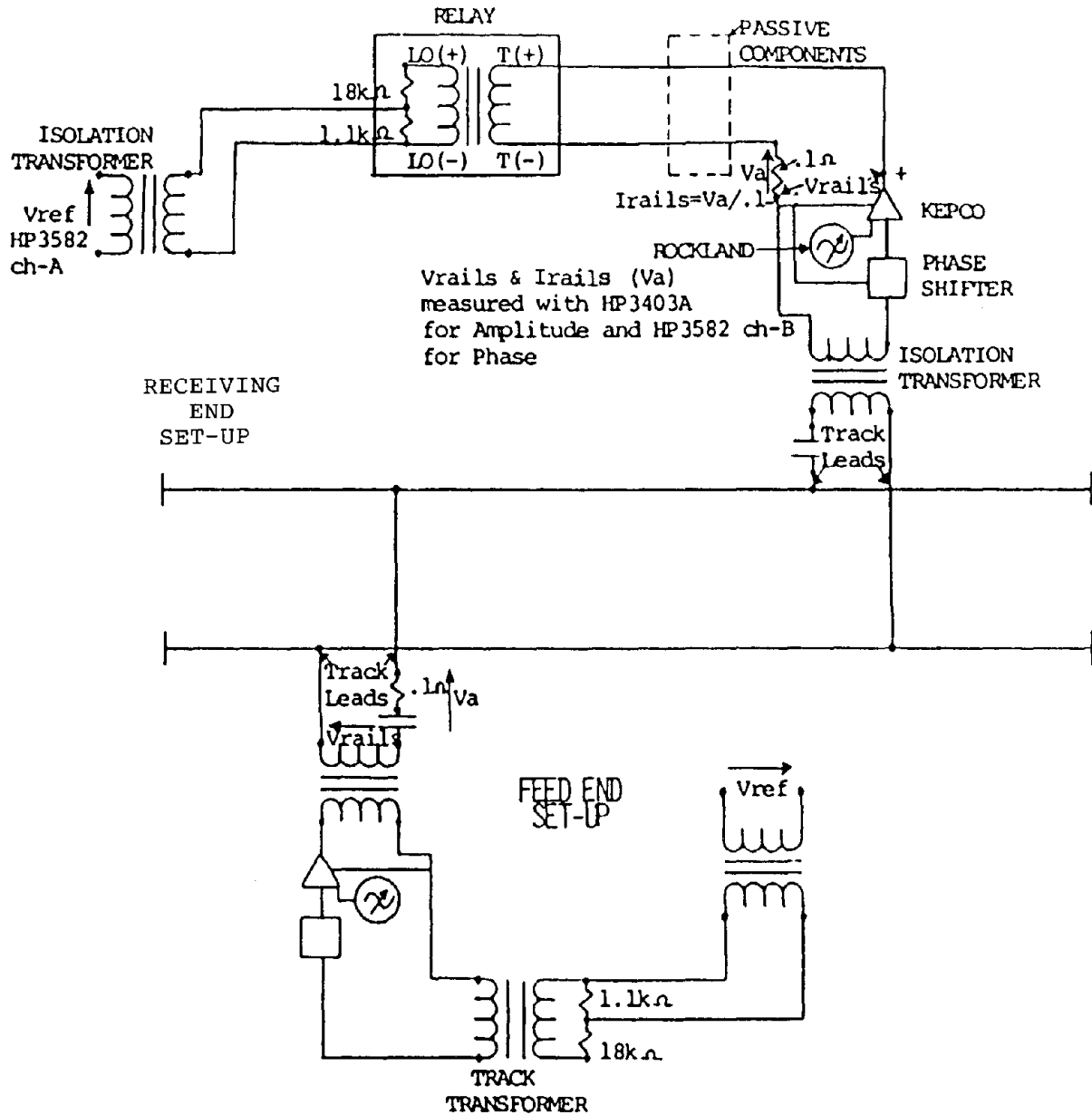
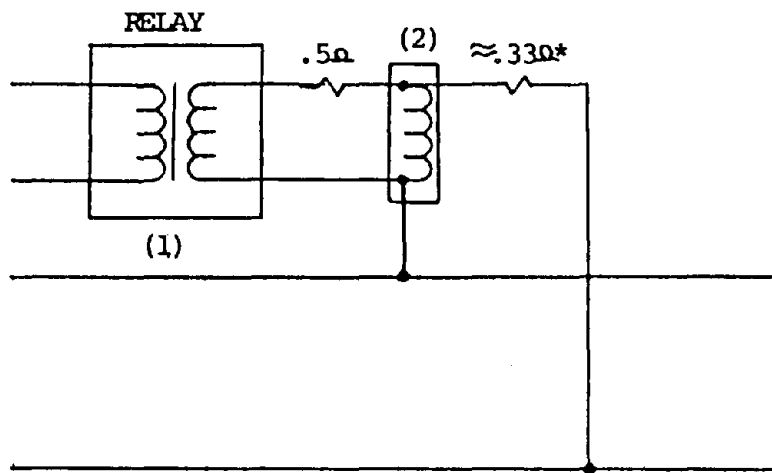

FIGURE B-1. GENERAL TEST SETUP AT BOTH ENDS OF THE TRACK CIRCUIT



1. RELAY - US&S PTV-42

LOCAL 115V .165A (112.3V MEASURED)

P.U. .78V .32A
 WORK 1.7V .48A
 CONTROL .82V .33A

2. SHIELDING REACTOR - US&S VG-12

$Z=6.0\Omega$ @ 60HZ
 $R=.063\Omega$

MAX I=20A

* Resistance not recorded but derived

FIGURE B-2. NYCTA TRACK CIRCUIT F3A-834 COMPONENTS

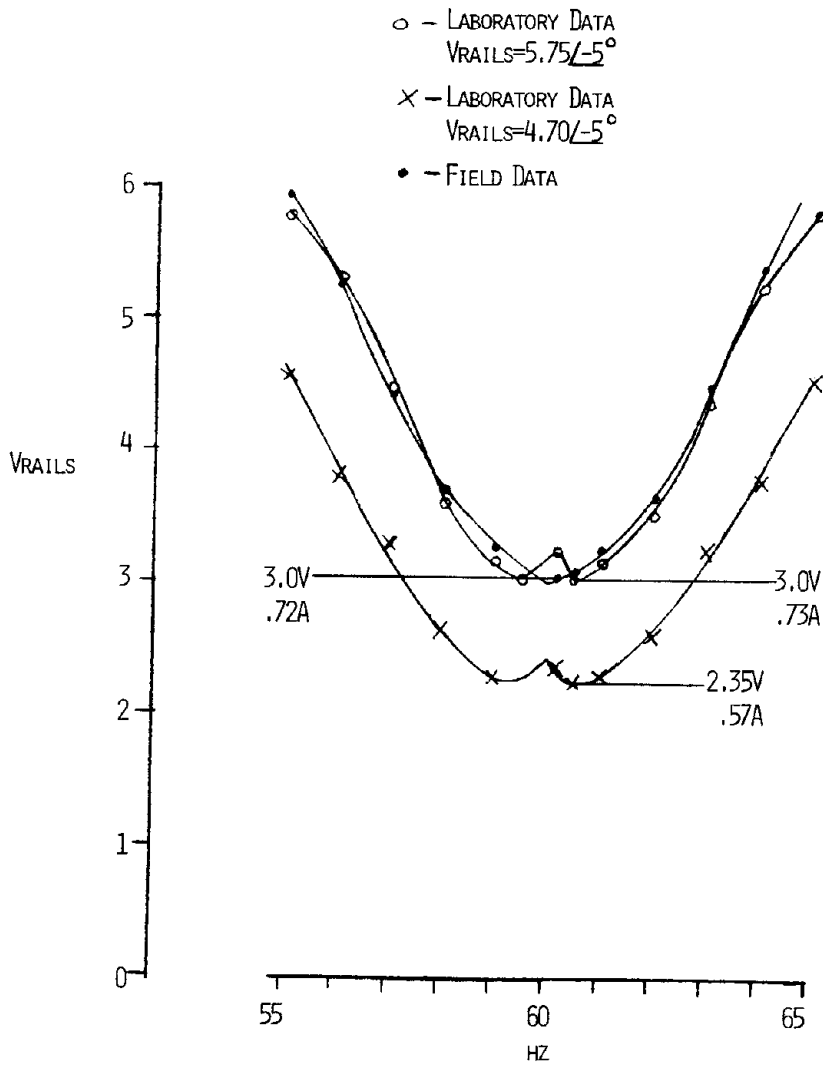

FIGURE B-3. NYCTA TRACK CIRCUIT F3A-834 INTERFERING VOLTAGE ACROSS LEADS FROM RAILS AT RECEIVING END FOR UNOCCUPIED CASE

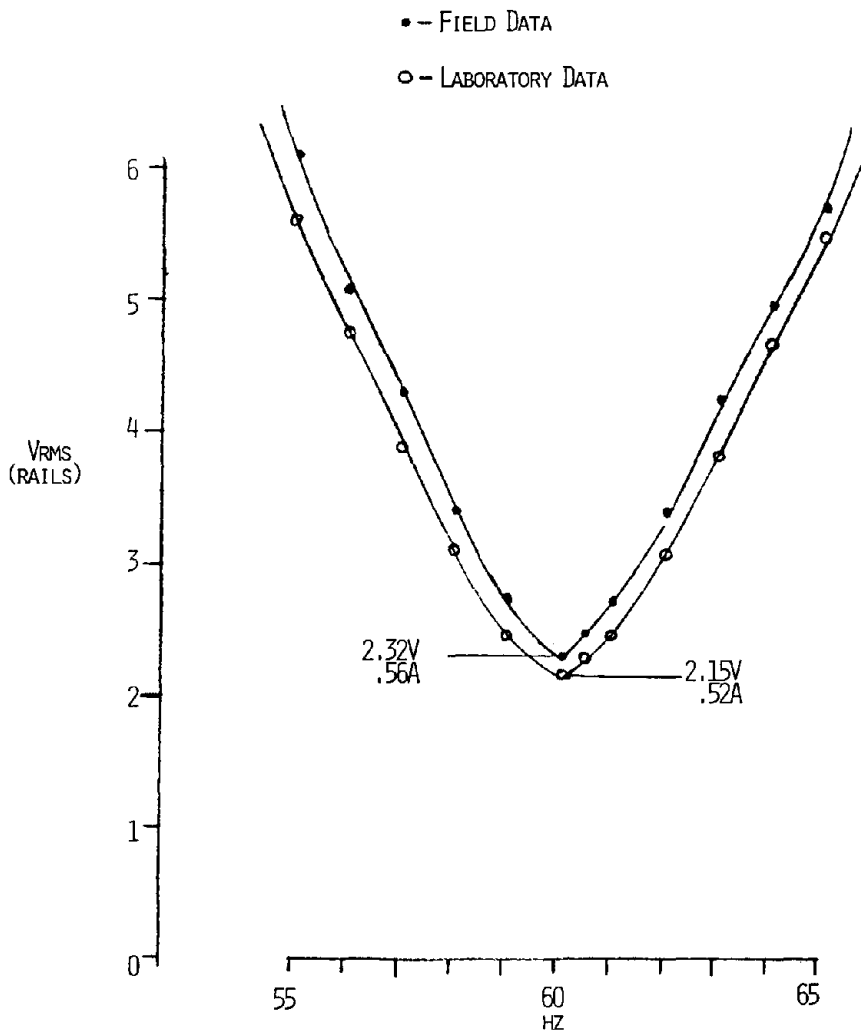

FIGURE B-4. NYCTA TRACK CIRCUIT INTERFERING VOLTAGE ACROSS LEADS FROM RAILS AT RECEIVING END FOR OCCUPIED CASE

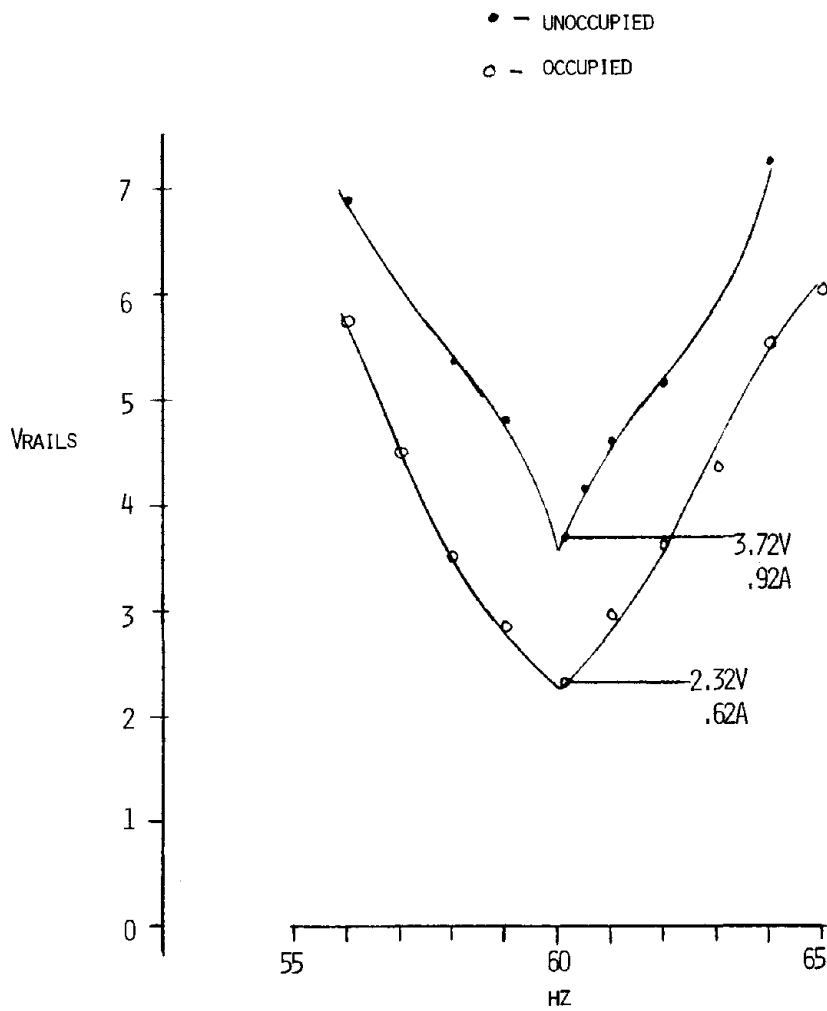
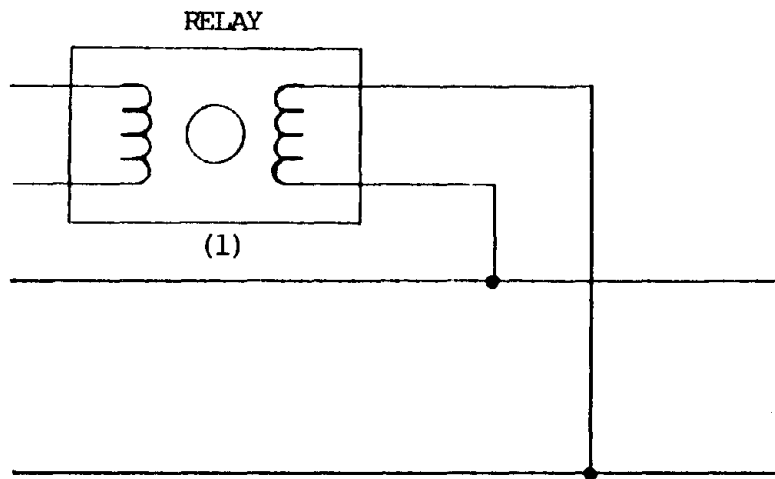

FIGURE B-5. NYCTA TRACK CIRCUIT F3A-834 INTERFERING VOLTAGE ACROSS LEADS TO RAILS TO FEED END FOR BOTH OCCUPIED AND UNOCCUPIED CASE



1. RELAY - GRS

TYPE M2FA 25HZ ROTOR TYPE

LOCAL 55V .29/-40° A (MEASURED)

FIGURE B-6. NYCTA TRACK CIRCUIT E4-744 COMPONENTS

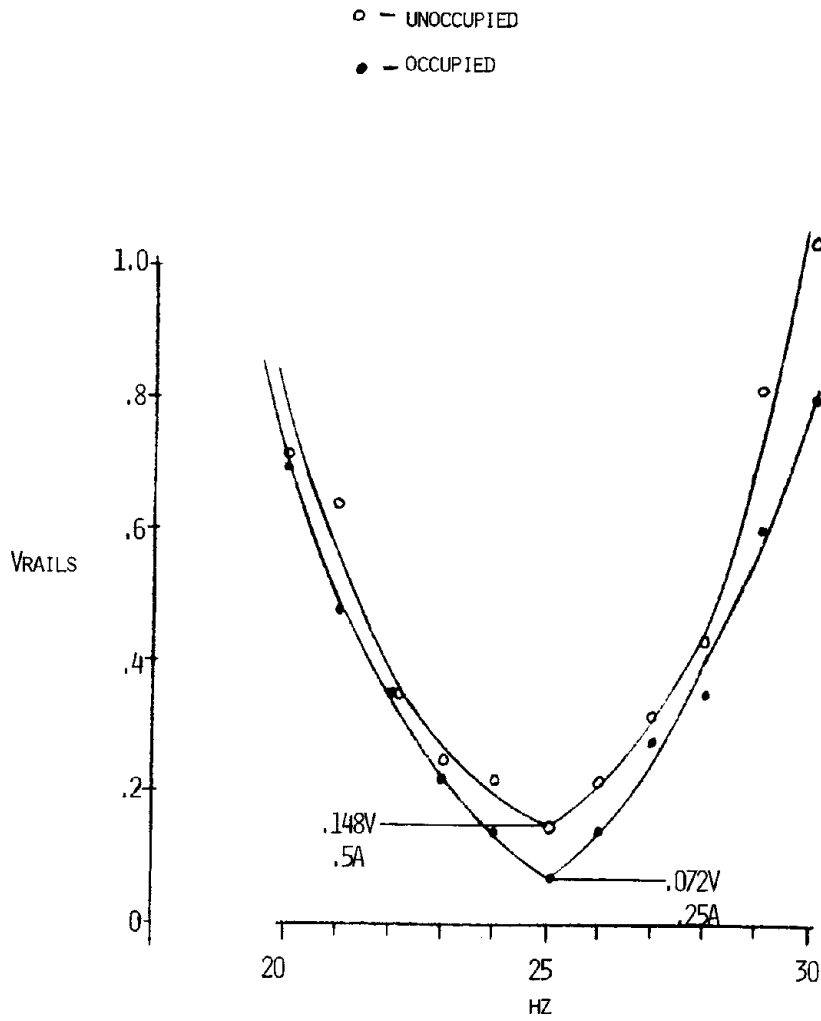
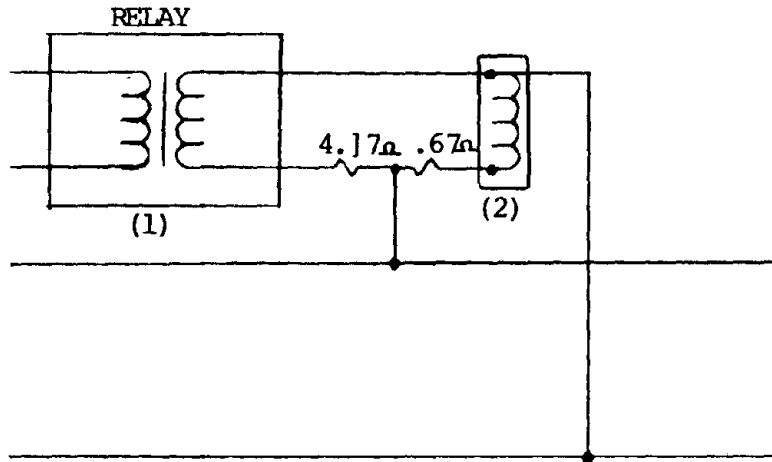

FIGURE B-7. NYCTA TRACK CIRCUIT E4-744 INTERFERING VOLTAGE ACROSS LEADS FROM RAILS AT RECEIVING END FOR BOTH OCCUPIED AND UNOCCUPIED CASE



1. RELAY - US&S

Pc 163975
 LOCAL 110V .4A

P.U. .72V .138A
 NORM 1.16V .22A

2. SHIELDING REACTOR - US&S VG-10

$Z = 6.2 \Omega$ @ 60HZ
 $R = .084 \Omega$

MAX I = .25A

FIGURE B-8. NYCTA TRACK CIRCUIT D-1492 COMPONENTS

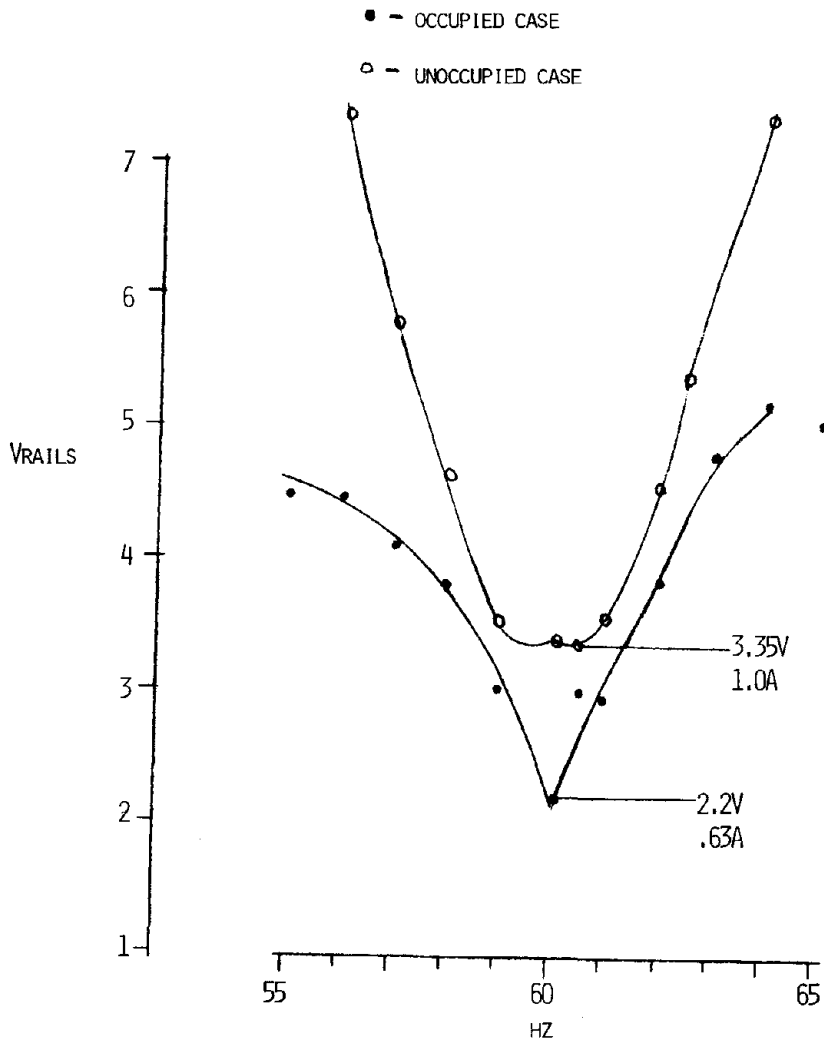

FIGURE B-9. NYCTA TRACK CIRCUIT D-1492 INTERFERING VOLTAGE ACROSS LEADS TO RAILS AT FEED END FOR BOTH OCCUPIED AND UNOCCUPIED CASE

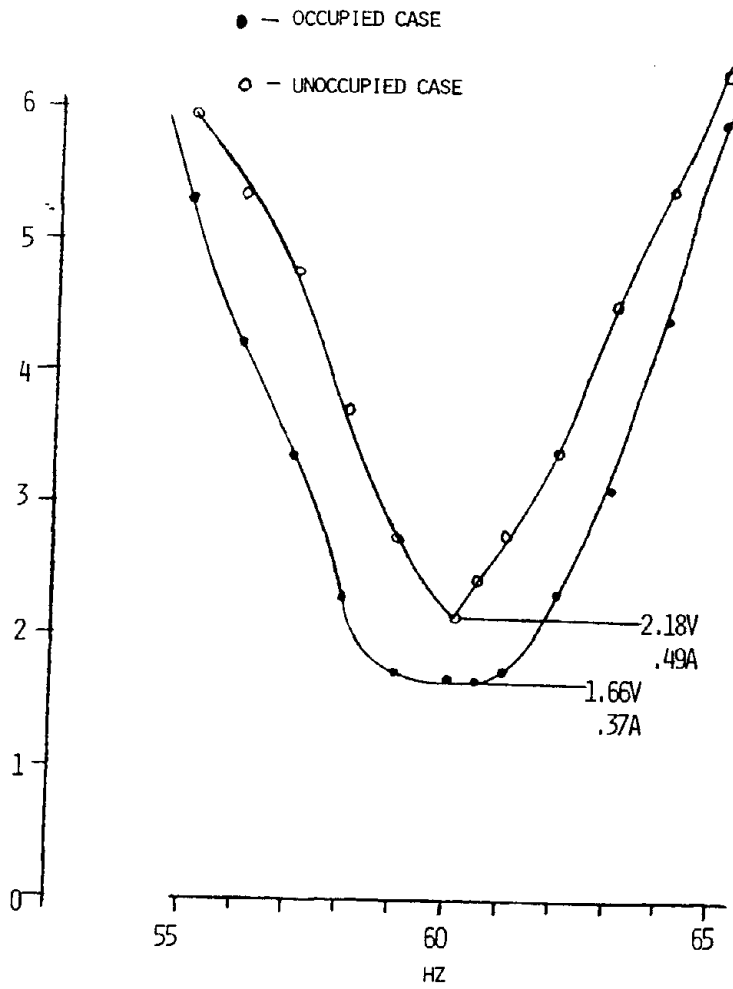

FIGURE B-10. NYCTA TRACK CIRCUIT D-1492 INTERFERING VOLTAGE ACROSS LEADS FROM RAILS AT RECEIVING END FOR BOTH OCCUPIED AND UNOCCUPIED CASE

APPENDIX C

EMI EFFECTS

on

VANE RELAY TRACK CIRCUITS

For Presentation and Discussion

at

Rail Transit EMI Working Group Meeting

Transportation Systems Center

June 9, 1983

UNION SWITCH & SIGNAL DIVISION

American Standard Inc.

Donald Stark, P.E.

A.G. Ehrlich, P.E.

EMI EFFECTS
on
VANE RELAY TRACK CIRCUITS

1.0 INTRODUCTION

This discussion deals with the behavior of vane relay track circuits in the presence of interference of the variable frequency type as generated by alternating current traction motor drives. Additional and more general information is contained in "EMI Susceptibility Characteristics, Power Frequency Track Circuits Using Vane Relays" which was presented for discussion at TSC Transit EMI Working Group Meeting February 7, 1980. A copy of this earlier paper is attached for reference.

2.0 BASIS OF DISCUSSION

The following factors are listed as the basis upon which the behavior of the track circuits is founded.

2.1 The track circuits have been properly designed to meet specifications with regard to train detection, and (except for single rail track circuits) broken rail detection.

2.2 Circuits are maintained in proper adjustment so as to preserve the original design characteristics.

2.3 The physical condition of track circuits, including minimum ballast resistance, cross bonding and rail bond conductivity, is maintained such as to support the original design characteristics.

2.4 The track circuit shunting characteristics of rolling stock and rail surface are maintained at or better than the specified value.

2.5 Under all conditions, including the worst case with regard to supply voltage, relay calibration and ballast resistance, the track relay of an unoccupied circuit will receive sufficient energy to at least make full stroke

(1.15 to 1.9 times pickup depending upon relay characteristics, where pickup is the energy level at which the front contacts close).

2.6 Under all conditions, including the worst case specification value rail to rail shunt resistance or with a broken rail (where applicable), the track relay energization will be decreased to or below the release value (0.80 to 0.90 times pickup depending upon relay characteristics).

3.0 SAFETY CONSIDERATIONS

During the course of normal operation of a variable frequency alternating current drive system, the frequency of the inverter will fall within the pass band of the signaling system for a significant time period. As indicated in the earlier paper, if the frequency difference between the reference and input (including interference) signals is small, the vane will cycle at the difference frequency. While this cycling condition may be detectable by operating personnel, it should be avoided as a matter of good system design practice. In addition, any condition which could cause sustained frequency and phase matching at interference levels sufficient to cause a false clear indication must be avoided.

Although single rail (traction return) track circuits do not provide broken rail detection, it is required of double rail track circuits. Interference components sneaking around the rail break through a parallel track or negative return cable via cross bonding connections must not cause false pickup of the track relay.

4.0 RELIABILITY CONSIDERATIONS

False track relay dropout is a manifestation of impaired operational reliability. Interference can cause movement of the vane. The range of such movement is a function not only of the magnitude and frequency of the interference but also of the prevailing track signal "over drive" or excess track signal during the interference exposure period. If vane movement is within the range which allows the relay front contacts to open when the track circuit is unoccupied, then reliability has been sacrificed. See phasor diagram in Figure C-1a.

5.0 LIMITING CLASS

Track circuits are designed to operate both safely and reliably even under worst case conditions of such factors as ballast leakage resistance, line voltage, track relay calibration, and shunting resistance. During actual operation, worst case limits must not be degraded by the introduction of additional energy from interference sources.

5.1 SAFETY

Considerations of limit cases with respect to safe transit system operation must include the case where a track circuit is occupied by a poor shunting car of train (Spec limit shunt) which, under worst case conditions, has reduced track relay energization to the release value. Under these conditions, it is only necessary for interference to increase the energy level to the pickup value to create a false clear condition. Further, in many transit systems, trip stops are held down over back contacts on the track relay. In many cases, it would be considered hazardous (to standing passengers) to allow interference to cause the back contact to open even momentarily due to the resulting sudden, unexpected brake application.

In the event of a false clear due to interference, the specific interference frequency and phase characteristics will determine if the false clear will be of a sustained or intermittent nature. Also, track circuits designed for higher shunting sensitivities tend to have less margin assignable to interference. In any case, the design of the overall signaling system will determine the impact of the incident with regard to transit system operation.

Broken rail detection must also be considered in double rail track circuits. Depending upon the nature of the break and track circuit parameters at the time, energization of the track relay may be reduced only to the release level. Under these conditions, the system margin for interference is the same as described above for train detection.

In reality, the margin for interference against a false clear (false unoccupied circuit) under these conditions is provided by the differential between release and pickup values for the track relay as shown in Figure C-1b. The margin in the case of falsely opening a track relay back contact in a trip

stop circuit is due mostly to friction within the relay mechanism, a small margin indeed. This condition is shown in Figure C-2. A similar situation occurs when a back contact of a track relay front repeater is used in the trip stop circuit except that the small circle in Figure C-2 would be centered on the "dropout/pickup" line instead of the release line.

5.2 RELIABILITY

Considerations regarding reliable operation of an unoccupied track circuit in the presence of interference are similar to those discussed above with respect to safety. The chief difference is that interference results in false track relay drop out. When all factors are at worst case limits, the track circuit is most susceptible to interference; that is, the relay is operating just at full stroke energization. Under these conditions the margin for interference against false dropout (false occupied circuit) is the full stroke to pickup differential of the relay.

6.0 CONCLUSION

It is difficult to predict how frequently worst case track circuit conditions will occur simultaneously with a limit case shunt or a broken rail. In some track circuits it may be possible to borrow some operating margin for EMI at the expense of reduced reliability with regard to safe side failures. However, prudent designs must avoid conditions which might produce a false clear.

The transit property on which the new variable frequency traction drives will operate should review operation of its circuits to assure that there has been no degradation of their characteristics since installation (due, for example, to aging or the effects of reduced minimum ballast leakage resistance, etc.). In addition, any track circuits which were installed such that they may operate at or near the limiting conditions with respect to shunting sensitivity (or broken rail detection where applicable) should be redesigned to increase operating margins to make room in the track circuit operating environment to accommodate the EMI generated by the new variable frequency alternating current traction motor systems.

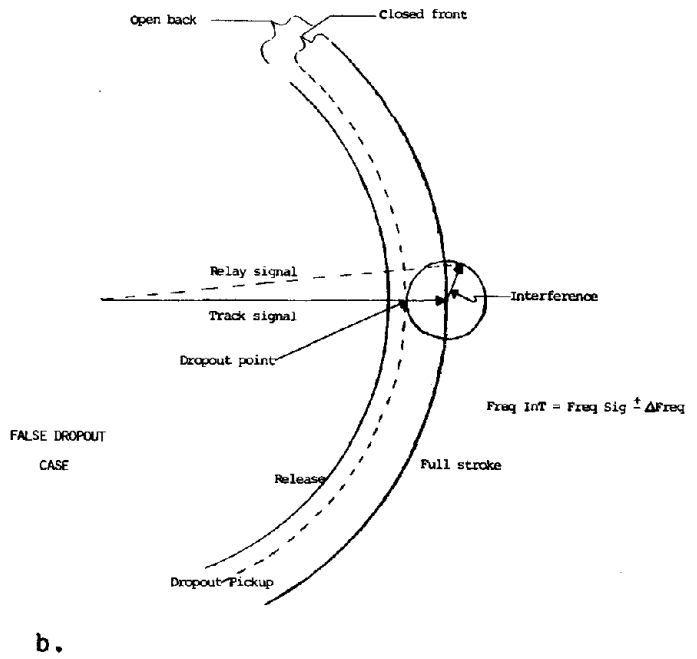
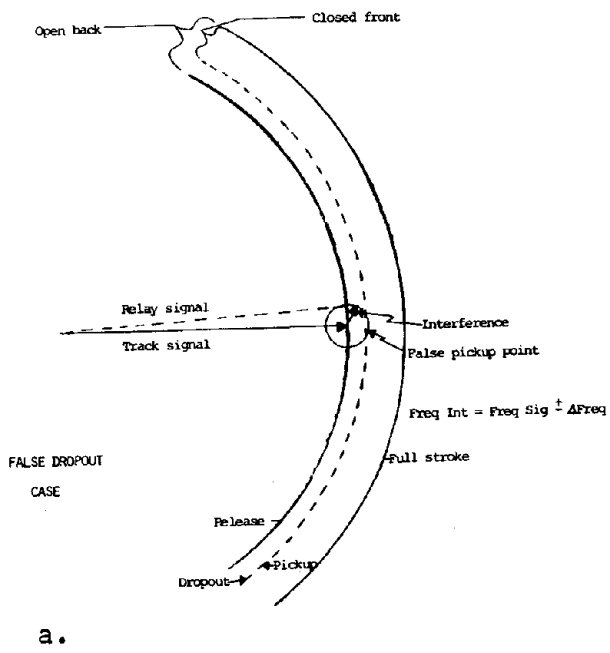

FIGURE C-1. FALSE DROPOUT CASE

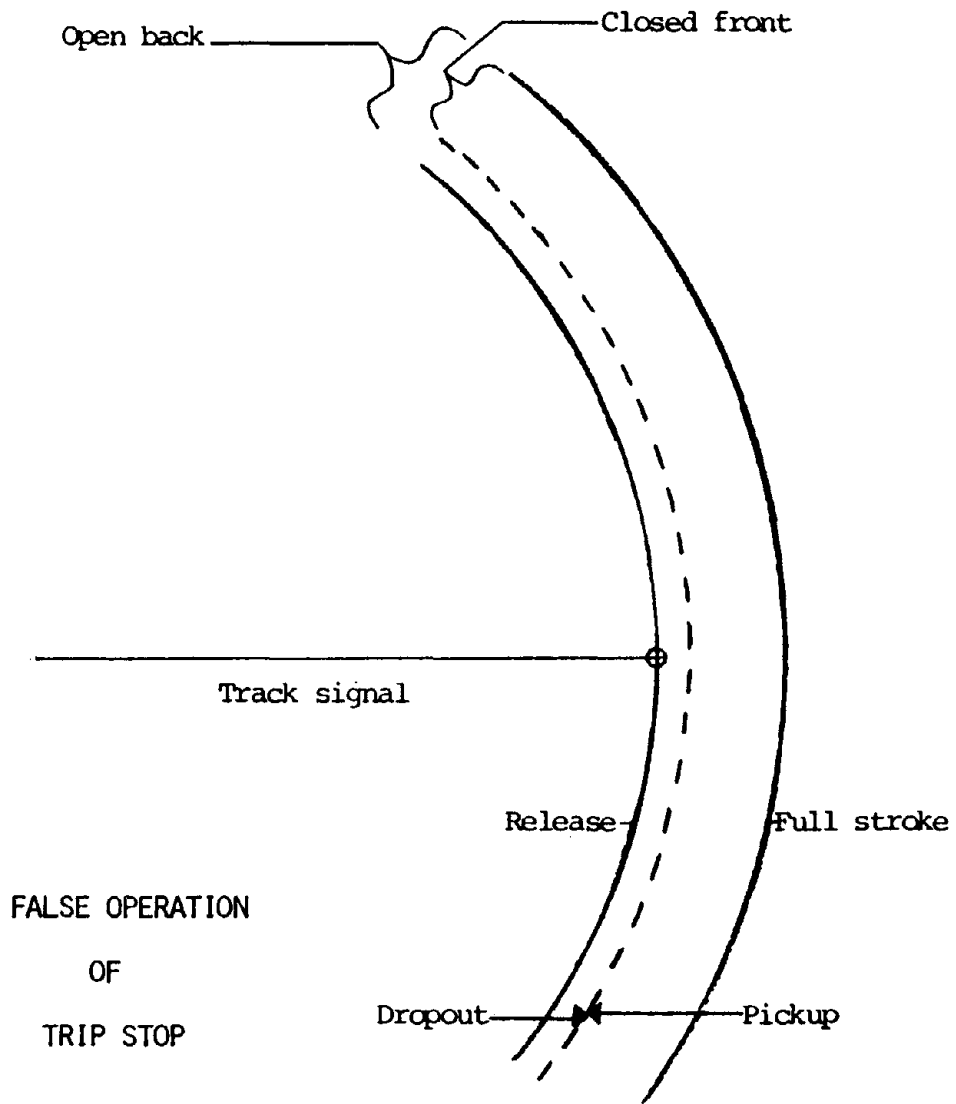
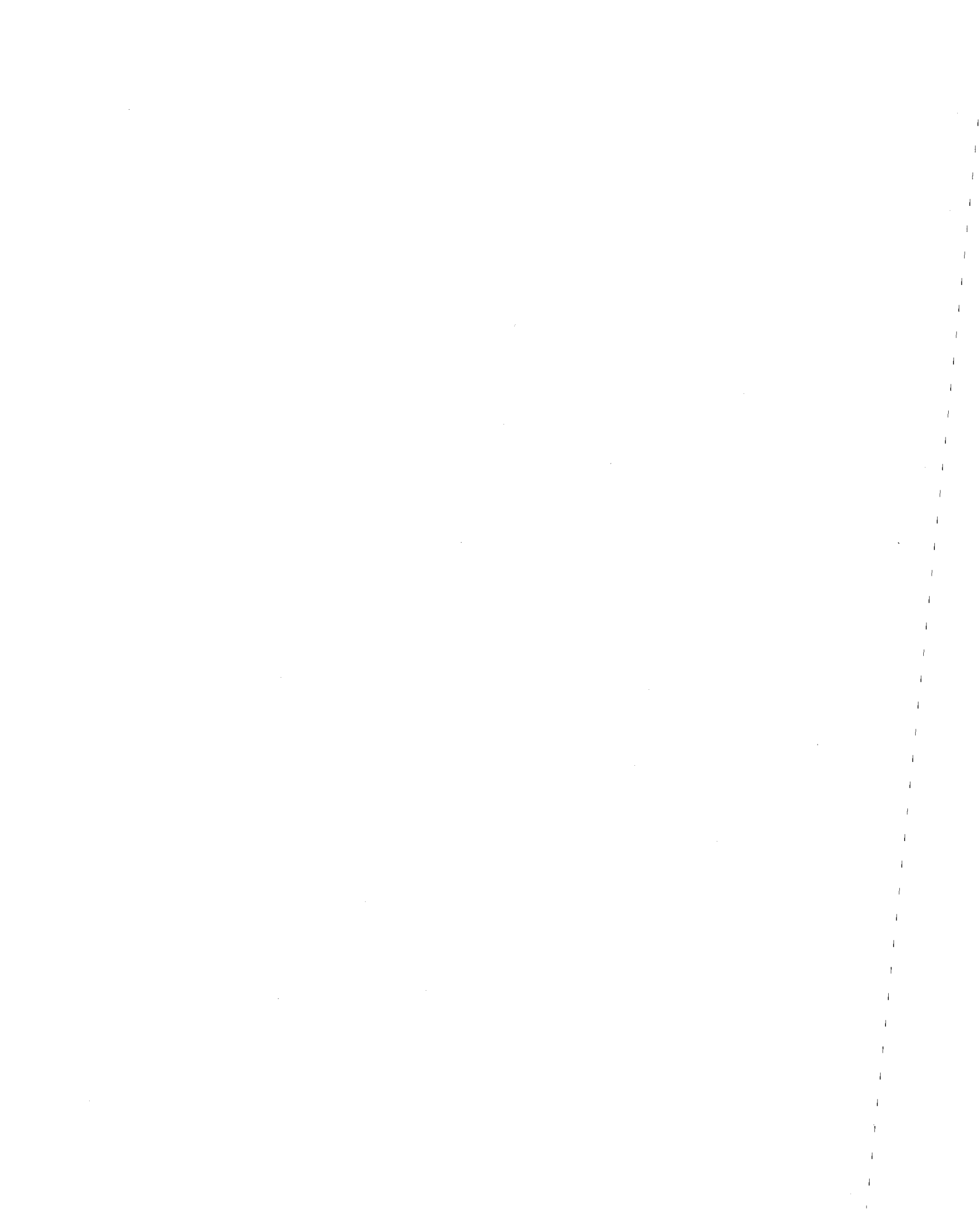

FIGURE C-2. FALSE OPERATION OF TRIP STOP



APPENDIX D

EMI SUSCEPTIBILITY CHARACTERISTICS

POWER FREQUENCY

TRACK CIRCUITS

USING

VANE RELAYS

FOR DISCUSSION AT TSC TRANSIT EMI

WORKING GROUP MEETING

FEBRUARY 7, 1980

UNION SWITCH & SIGNAL DIVISION

AMERICAN STANDARD INC.

Donald E. Start, P.E.

1. INTRODUCTION

One of the common alternating current track circuits used today in transit signaling systems operates at frequencies between 25 Hz and 100 Hz. These circuits often utilize 60 Hz commercial power and employ two-element or two phase detectors such as vane relays in either single rail or double rail track circuits. They have many advantageous characteristics but like all communication devices, they have a finite tolerance to "in band" interference.

This brief discussion is an attempt to bring the subject of Electromagnetic Interference (EMI) in this type of application into proper perspective. The remarks contained herein pertain almost exclusively to the receiving device (vane relay) itself. However, the coupling mechanisms referred to in a previously published paper, US&S Bulletin 319, may be applied to bridge the gap from the relay back into the track circuit where interference may be coupled from the onboard traction control systems and traction power supply system.

2. EMI SUSCEPTIBILITY OF VANE RELAY

Figure D-1 shows the interference susceptibility of a typical two-element vane relay with its local coil energized at Frequency F_0 , the signaling power supply frequency. The level "P.U." represents the track coil current for pick up at ideal phase. This is the most sensitive condition. As the track coil frequency deviates either above or below F_0 , the track coil current required to cause contact operation increases. In effect, the vane relay is a selective electromechanically tuned bandpass filter. For the range of frequencies and current below the curve, reliable signal system performance is assured. However, in areas closer to the curve, the mechanism of the vane relay is subject to greater physical stress due to vibration. For optimum life, it is desirable to restrict the product of level and time of exposure to a satisfactory low value. Thus, long time exposure must be limited to lower interference levels while short time exposure may be permitted at higher levels but still under the curve.

If interference levels fall about the curve, momentary contact operation can occur. That is, a back contact may open momentarily when the track circuit is occupied or a front contact may open for a brief period when the track

circuit is unoccupied. These, of course would be failsafe situations insofar as the signaling system is concerned.

If the interference should invade the shaded portion of the chart within a few Hertz of F_0 , the vane and contacts will cycle. That is to say, the contacts will open and close periodically at the difference frequency. The limits of frequency deviations, under which this phenomenon will occur are determined by the design of the relay and particularly the mass of the moving parts.

Operation in this region is, of course, unsafe and must be avoided by proper EMI coordination. In any case, however, the failure would be detectable since it would be cyclic and apparent to operating personnel. The only condition which can produce prolonged and, hence, undetectable and unsafe false operation would be if the track coil were energized with a current at frequency F_0 and if the phase relations between the track and local signals were constantly within the operable range of the vane relay. That is, both frequency and phase criteria must be met to produce an unsafe and undetectable failure. Phenomena capable of producing interference with two independent variables so closely matched are indeed rare.

3. EVALUATION CRITERIA

Numerous system variables determine the proportion of traction alternating current component which is coupled to the vane relay. Double rail track circuits couple a smaller portion of the interfacing component than single rail track circuits. Also, particularly in the single rail case, circuit length is an important factor.

The effects of interference should be considered separately with regard to safety and with regard to reliability.

A. SAFETY

Safety cannot be compromised. All factors which can result in unsafe operation must be fully evaluated and no undetectable failure should result in unsafe performance.

B. RELIABILITY

Physical stress such as caused by violent perturbations of the vane element is an important factor in determining the operational life of the vane relay.

Thus, the impact of interference becomes a statistical consideration in the overall determination of device reliability. That is, the less the physical stress, the longer the useful life of the relay.

In reality, the effects of physical stress are a function of both the intensity of the interference and the time of exposure. Statistical determination of physical stress is therefore unique to each application and includes considerations of the following items.

1. Type of track circuit
2. Magnitude and frequency of interfering signal
3. Traffic density over the track circuit
4. Specific characteristics of the relay.

SUMMARY

Different designs of hardware (vane relay) undoubtedly will have different interference response characteristics, particularly regarding rejection as a function of frequency. In addition, the statistical tolerance to physical stress will depend on the specifics of hardware design and the method of application to a particular signaling system.

Much of the background is covered in the attached paper, US&S Bulletin 319, which was presented to an APTA meeting in 1977. The difficult part to quantify will be the statistical approach to reliability which will be unique to each design and application and which, at least for new, remains with the area of propriety information.

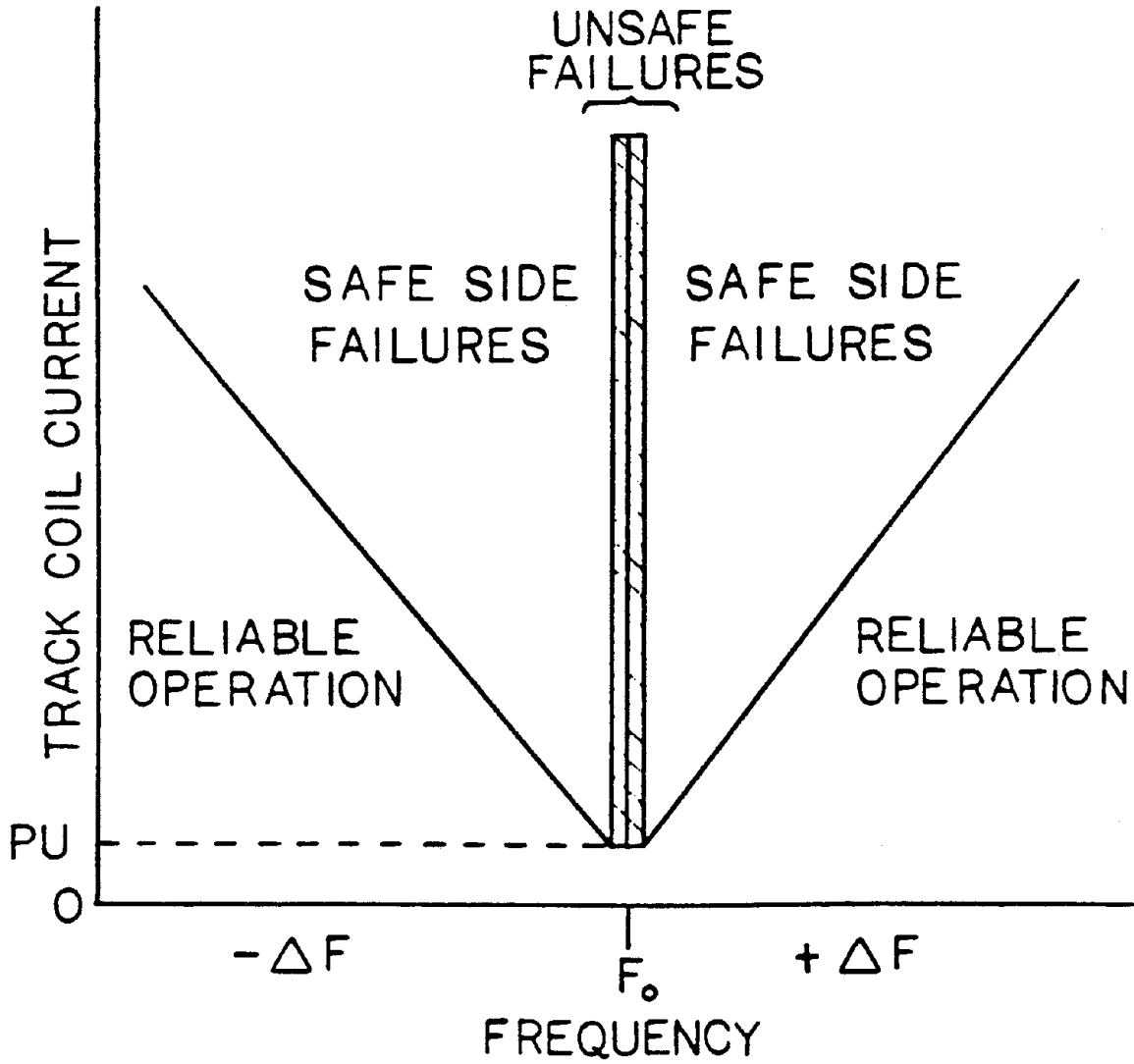

FIGURE D-1. SUSCEPTIBILITY OF VANE RELAY

DEFINITIONS

Vane Relay Operation

- e_{SIG} = Rail - Rail Track Signal At Receiving End
 e_{PU} = Rail - Rail Signal to Close Front Contact
 e_{DA} = e_{PU} Assuming Aero Friction etc.
 e_{REL} = Rail - Rail Signal to Close Back Contact
 e_{MAR} = Margin for Interference Under Prevailing Conditions

Limiting Cases

1. False Pick-Up (Close Front)

$$e_{MAR} = e_{PU} - e_{SIG}$$

2. False Drop-Away (Open Front)

$$e_{MAR} = e_{SIG} - e_{PU} + \text{Friction Effects}$$

3. False Trip Stop Release (Open Back)

$$e_{MAR} = e_{REL} - e_{SIG} + \text{Friction Effects}$$

Note: Worst case considerations should include Prevailing e_{SIG} . re: Imperfect Shunting and broken rail conditions.

US&S 7/31/83 D.E. Stark

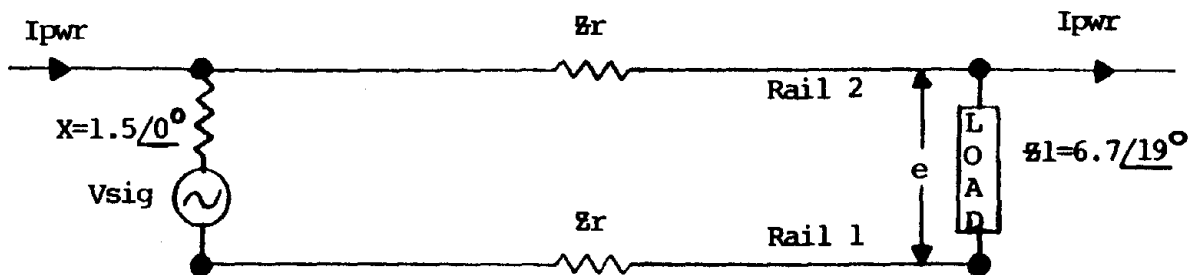

$$Z_{TK} = 2Z_R - Z_{M_{12}} = .23 / 75^\circ \text{ } / M_{ft}$$

$$Z_{M_{12}} = Z_R / 2 \text{ (FOR 1000 FT OF 5' GA. TRACK)}$$

$$Z_R = .23 / 75^\circ$$

$$e_{pwr} = \frac{I \cdot Z_R \cdot Z_l}{Z_{TK} + X + Z_l} = 0.18 \text{ V/AMP (TEST \#6)}$$

FIGURE D-2. INTERFERENCE TRANSFER "DRY" BALLAST

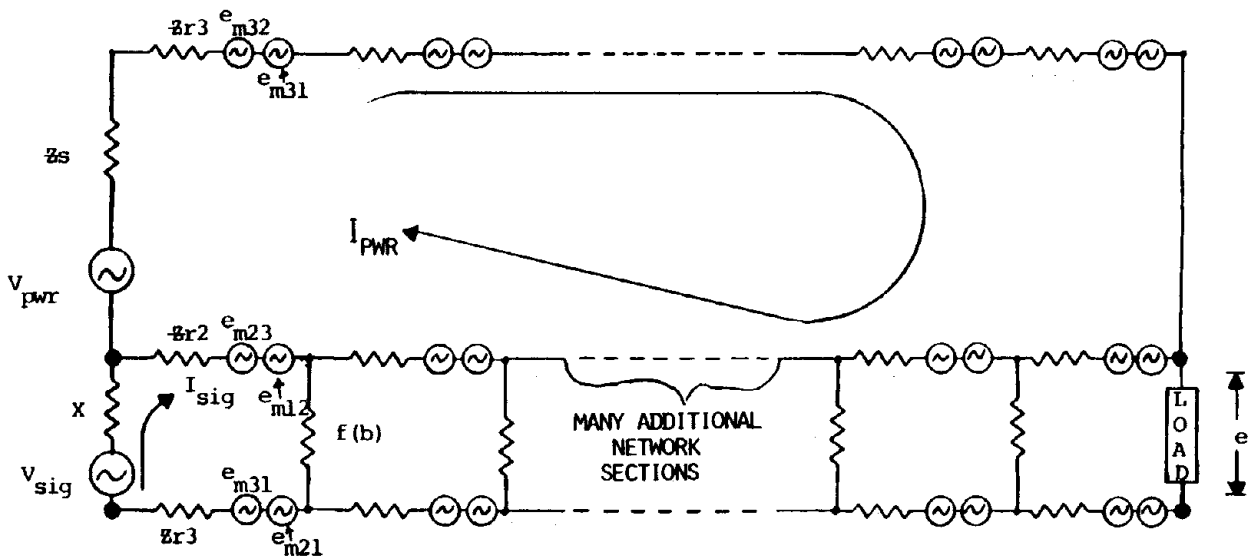

FIGURE D-3. TRACK CIRCUIT INTERFERENCE COUPLING MODEL

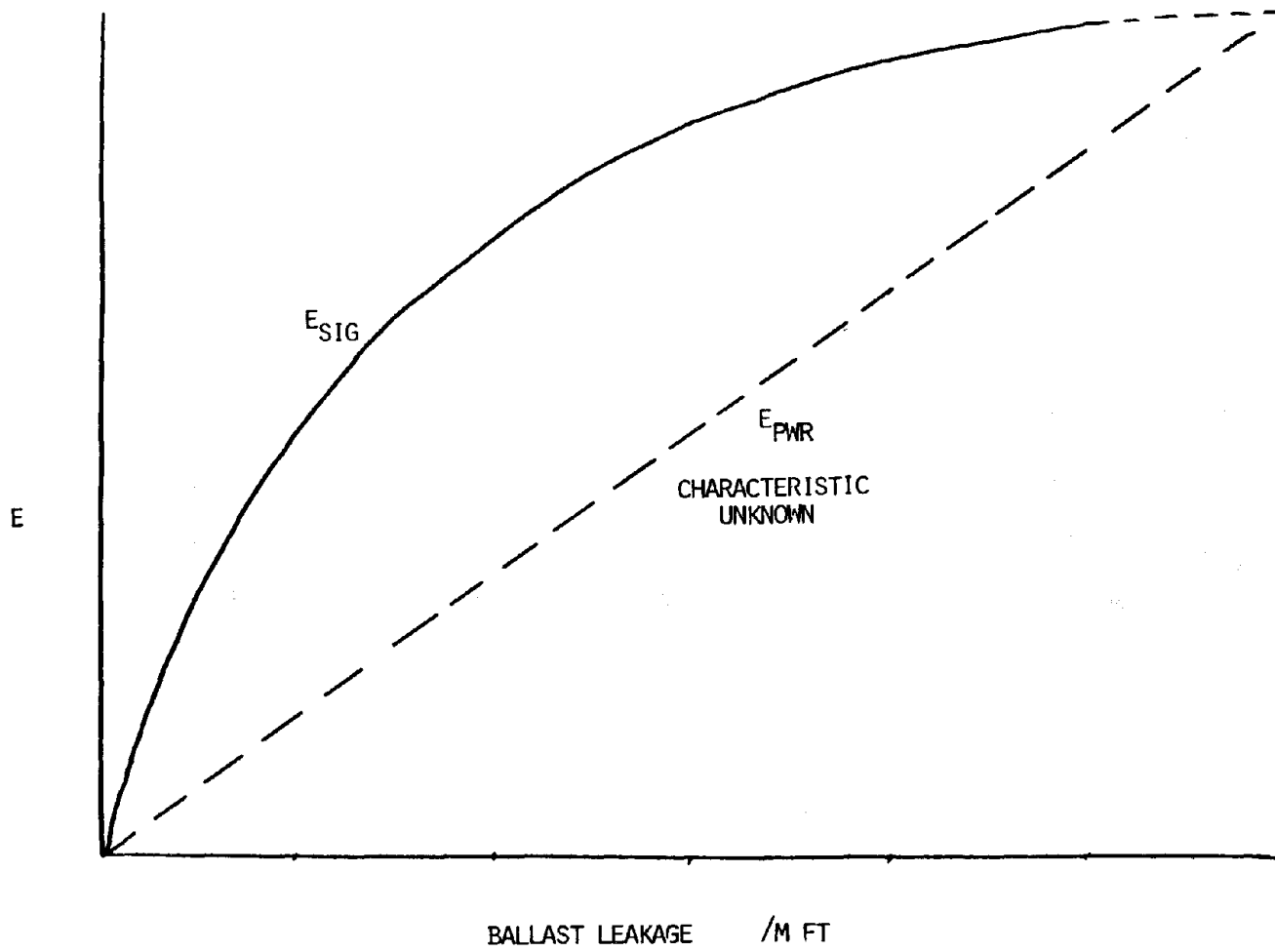

FIGURE D-4. SIGNAL AND INTERFERENCE PROPAGATION IN TRACK VS. BALLAST LEAKAGE

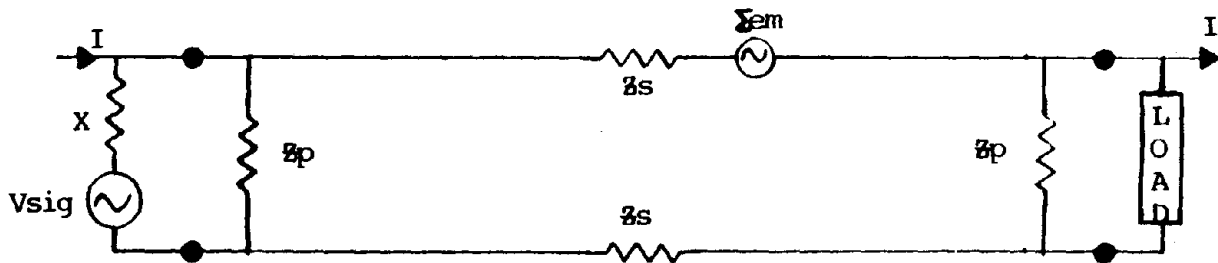

FIGURE D-5. EQUIVALENT TRACK CIRCUIT TT NETWORK

☆ U. S. GOVERNMENT PRINTING OFFICE: 1986--601-145--20,219