

PB294-840



REPORT NO. UMTA-MA-06-0025-79-1, I

ELECTRICAL INSULATION FIRE CHARACTERISTICS
Volume I: Flammability Tests

L.E. Meyer
A.M. Taylor
J.A. York

Boeing Commercial Airplane Company
P.O. Box 3707
Seattle WA 98124



FINAL REPORT
DECEMBER 1978

DOCUMENT IS AVAILABLE TO THE U.S. PUBLIC
THROUGH THE NATIONAL TECHNICAL
INFORMATION SERVICE, SPRINGFIELD,
VIRGINIA 22161

Prepared for
U.S. DEPARTMENT OF TRANSPORTATION
URBAN MASS TRANSPORTATION ADMINISTRATION
Office of Technology Development and Deployment
Office of Rail and Construction Technology
Washington DC 20590

REPRODUCED BY: **NTIS**
U.S. Department of Commerce
National Technical Information Service
Springfield, Virginia 22161

NOTICE

This document is disseminated under the sponsorship of the Department of Transportation in the interest of information exchange. The United States Government assumes no liability for its contents or use thereof.

NOTICE

The United States Government does not endorse products or manufacturers. Trade or manufacturers' names appear herein solely because they are considered essential to the object of this report.

1. Report No. UMTA-MA-06-0025-79-1		2. Government Accession No.		3. Recipient's Catalog No. PB294840	
4. Title and Subtitle ELECTRICAL INSULATION FIRE CHARACTERISTICS Volume I: Flammability Tests				5. Report Date December 1978	
				6. Performing Organization Code	
7. Author(s) L. E. Meyer, A. M. Taylor, J. A. York				8. Performing Organization Report No. DOT-TSC-UMTA-78-48, I	
9. Performing Organization Name and Address Boeing Commercial Airplane Company* P.O. Box 3707 Seattle, Washington 98124				10. Work Unit No. MA-06-0025(UM804/R9723)	
				11. Contract or Grant No. DOT-TSC-1221	
12. Sponsoring Agency Name and Address U. S. Department of Transportation Urban Mass Transportation Administration 400 Seventh Street, S. W. Washington, D. C. 20590				13. Type of Report and Period Covered Final Report July 1976-July 1978	
				14. Sponsoring Agency Code	
15. Supplementary Notes *under contract to: U.S. Department of Transportation, Research and Special Programs Administration, Transportation Systems Center, Cambridge, MA 02142. The other volume in this set is: <u>Electrical Insulation Fire Characteristics - Volume II: Toxicity</u> , and is also available from National Technical Information Service					
16. Abstract In the crowded, confined environment of a rapid transit vehicle, it is essential that smoke emission from all sources be minimized. The adoption of test standards and guidelines for wire and cable used in these vehicles must be undertaken in an organized, well-coordinated program in which flammability, smoke emission, toxic gas evolution, and circuit integrity are treated as interrelated components of a system. As a result of this need, standard flammability, smoke emission, and circuit integrity tests were developed for electrical wire and cable insulating materials used in rapid transit system vehicles and wayside and track installations. The objective of the program was to determine if any of the currently used materials can provide a fire-safe environment in terms of low flame propagation, smoke emission, and gas evolution, and determine whether any of these can meet criteria which will be established by taking into account the fire hazards inherent in transit systems. Wire and cable insulating materials currently in use on rapid transit systems and new polymeric materials proposed for such systems, were requested from manufacturers who had given indication of interest in the program. These samples were tested and ranked with respect to their performance during the tests. The report presents a discussion of the need for such standard tests, the criteria for the selection of a test method, the development of the test details, and a description of the standard tests. The study concludes that the objectives of the program have been achieved. Other conclusions and recommendations are presented. This report contains Appendices A through D: <u>Method of Performing Comparative Analysis; Analysis of Existing Smoke Test Methods; IEEE-383-1974 Test Method; and Inventions</u> , respectively. An Addendum: <u>Inhalation Toxicity of Thermal Degradation Products from Electrical Insulation</u> , is also included.					
17. Key Words Electrical Insulation; Fire Prevention and Control; Flammability; Guidelines; Insulation; Rail - Rapid Transit; Rapid Transit Systems; Safety; Toxicity; Testing Facilities			18. Distribution Statement Available to the Public through the National Technical Information Service Springfield, Virginia 22161.		
19. Security Classif. (of this report) Unclassified		20. Security Classif. (of this page) Unclassified 1A		21. No. of Pages	22. Price PC-A11 MF-A01

PREFACE

This document presents the results of DOT/TSC contract #1221, "Electrical Insulation Fire Characteristics." The contract was conducted by the Boeing Commercial Airplane Company, Seattle, Washington, from July 1976 through July 1978. The DOT/TSC gave an associated contract (DOT/TSC 1277) to the American Public Transit Association (APTA). The purpose of this concurrent contract was to provide transit industry input, advice, and consensus on electrical insulation fire characteristics.

The first two introductory sections of the document present background information regarding the need for the study and a brief description of the rapid transit system model used as the basis for the study. The next sections focus on the selection and development of test methods to determine the flammability, smoke emission, and toxic gas evolution characteristics of wire and cable insulations. The latter sections of the document present the results of subjecting various wire and cable insulations and constructions to the tests developed. Finally, an attempt is made to rank the insulation materials according to their performance during the tests.

I. Litant was the Technical Monitor for this project.

METRIC CONVERSION FACTORS

Approximate Conversions to Metric Measures

Symbol	When You Know	Multiply by	To Find	Symbol
LENGTH				
in	inches	2.5	centimeters	cm
ft	feet	30	centimeters	cm
yd	yards	0.9	meters	m
mi	miles	1.6	kilometers	km
AREA				
m ²	square inches	6.5	square centimeters	cm ²
ft ²	square feet	0.09	square meters	m ²
yd ²	square yards	0.8	square meters	m ²
mi ²	square miles	2.6	square kilometers	km ²
	acres	0.4	hectares	ha
MASS (weight)				
oz	ounces	28	grams	g
lb	pounds	0.45	kilograms	kg
	short tons (2000 lb)	0.9	tonnes	t
VOLUME				
teaspoon	teaspoons	5	milliliters	ml
tablespoon	tablespoons	15	milliliters	ml
fl oz	fluid ounces	30	milliliters	ml
c	cups	0.24	liters	l
pt	pints	0.47	liters	l
qt	quarts	0.95	liters	l
gal	gallons	3.8	liters	l
cu ft	cubic feet	0.03	cubic meters	m ³
yd ³	cubic yards	0.76	cubic meters	m ³
TEMPERATURE (exact)				
°F	Fahrenheit temperature	5/9 (after subtracting 32)	Celsius temperature	°C

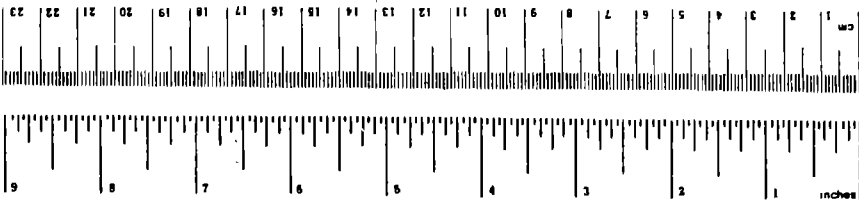

Approximate Conversions from Metric Measures

Symbol	When You Know	Multiply by	To Find	Symbol
LENGTH				
mm	millimeters	0.04	inches	in
cm	centimeters	0.4	inches	in
m	meters	3.3	feet	ft
km	kilometers	1.1	yards	yd
		0.6	miles	mi
AREA				
cm ²	square centimeters	0.16	square inches	in ²
m ²	square meters	1.2	square yards	yd ²
km ²	square kilometers	0.4	square miles	mi ²
ha	hectares (10,000 m ²)	2.6	acres	ac
MASS (weight)				
g	grams	0.035	ounces	oz
kg	kilograms	2.2	pounds	lb
t	tonnes (1000 kg)	1.1	short tons	st
VOLUME				
ml	milliliters	0.03	fluid ounces	fl oz
l	liters	2.1	pints	pt
		1.06	quarts	qt
		0.26	gallons	gal
m ³	cubic meters	35	cubic feet	ft ³
		1.3	cubic yards	yd ³
TEMPERATURE (exact)				
°C	Celsius temperature	9/5 (then add 32)	Fahrenheit temperature	°F

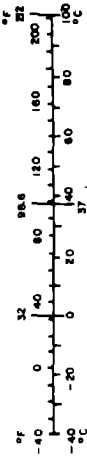

EXECUTIVE SUMMARY

The hazard of fire has long been a concern to the transportation industry. In recent years, attention has been focused on the effects of smoke produced from burning or smoldering rather than on the immediately apparent effects of toxic gases, the area previously of interest. Recent studies have shown that incapacitation or death from smoke is more probable than from fire. In the crowded, confined environment of a rapid transit vehicle, it is essential that smoke emission from all sources be minimized. Criteria for the amount of smoke that can be tolerated and standard methods for measuring smoke emission need to be established.

The problem of an "allowable" quantity of smoke is compounded by the possibility of toxic fumes in the smoke. The use of halogenated monomers as flame retardants in the basic polymer chain brings with it the problem of the emission of hydrogen-halogenated gases as well as halogenated compounds. It is extremely difficult to categorize wire and cables in this respect because of the different gases and compounds formed at different combustion, smoldering, or current-overload-induced temperatures. Standard criteria and test methods are required to properly characterize the toxic gas evolution properties of electric wire and cable.

Another problem in the selection of flammability and smoke emission criteria is that the integrity of the wire and cable must be maintained in circuits that are essential for the continued safety of the passengers and vehicle during and after a fire. Some of the insulations used to reduce flammability and smoke emission problems char or even melt and fall off the conductor. Currently, no accepted criteria or test methods exist to guide wire and cable manufacturers, vehicle manufacturers, or transit authorities.

None of these problems are insurmountable. The Urban Mass Transportation Administration (UMTA), working through the Transportation Systems Center, recognized these problems. They also recognized that the adoption of test standards and guidelines for wire and cable used in rapid transit systems must be undertaken in an organized, well-coordinated program in which flammability, smoke emission, toxic gas evolution, and critical circuit integrity are treated as interrelated components of a system.

After receiving competitive proposals, DOT awarded contract DOT-TSC-1221, "Electrical Insulation Fire Characteristics," to the Boeing Commercial Airplane Company in July 1976. A separate contract was awarded to the American Public Transit Association (APTA) to support the Transportation Systems Center and to bring to this work their knowledge and experience.

The objective of the program was to determine if any of the currently used electrical insulation materials can provide a fire-safe environment in terms of low flame propagation, smoke emission, and gas evolution. Examination of literature and interviews of a few of the larger rapid transit authorities were to be made to determine the details of transit system fires involving electrical insulation. A review was to be made of the various flammability test methods for wire and cable to determine which are the most appropriate to use in evaluating wire and cable for use in transit systems. Smoke test methods and guidelines were to be investigated. The National Bureau of Standards (NBS) smoke chamber was to be used where practical. Guidelines and test methods for determining suitable insulation for wire used in critical circuits were to be prepared. The materials and design of the samples of wire and cable were to be determined by the experience and recommendations of wire and cable manufacturers. These samples were to be tested for flammability, smoke and toxic gas emission, and circuit integrity. All samples of insulation materials were to be evaluated and ranked.

In addition, DOT/TSC Contract No. RA-77-15, "Inhalation Toxicity of Thermal Degradation Products from Electrical Insulation," was awarded to FAA-Civil Aeromedical Institute (CAMI) in July 1977 to determine the relative inhalation toxicity of the products of combustion (thermal degradation) of various types of electrical insulation. An executive summary of this report is included as an addendum to this report.

The electrical insulation fire characteristics project began in July 1976 and was completed in July 1978. This report presents the results of the test program.

The rapid transit system chosen for this study consists of two components, the vehicle and the wayside and track installation. The vehicle receives

its power via the third-rail pickup shoe interface. The pickup shoe assembly often becomes covered with contamination and is a potential source of fire as a result of the energy from arcing that takes place between the shoe and the third rail. Vehicle maintenance programs must include regular cleaning of the pickup shoe assembly.

Car designers route wire and cable under the floor of the passenger compartment as much as possible to minimize the hazard of fire and smoke emanating from it. The severe environment to which the wiring is exposed is a drawback to this approach. Heavier insulation becomes necessary, increasing the potential for fire, smoke, and toxic gases. Safety precautions such as fuses are employed in addition to the external routing of the wire. Voltage rating of wires range from 0.6 kV for control circuits to 2.5 kV for traction power circuits. There is a variety of criteria for the selection of wire and cable, but generally, no governmental or regulatory constraints govern wire and cable selection or installation on rapid transit vehicles.

Traction power ranges from 600 to 1,000 volts dc and is supplied from the third rail. Most of the wire used for traction power is 2000 MCM with an insulation of neoprene or synthetic rubber jacketed ethylene propylene rubber rated at 1,000 volts. Numerous other wires and cables are installed in the tunnels, waysides, and stations to provide power for communications, train command and control information, lights, and ventilating fans. There are various methods of installing wire and cable in tunnels. A typical method is to run all wires in lined ducts embedded in concrete; the advantage of this method is that a fire in one wire or cable cannot propagate beyond that duct, and flame and smoke are contained, thereby minimizing the effect on the passengers. In general, standard building and electrical codes are applied to the construction of tunnels and stations.

Fires have been attributed to numerous causes ranging from debris collecting near the third rail and subsequently being ignited by the arcing of the pickup shoe of a passing train or by ground faults of third-rail feeders, to hot breaking resistors and battery faults. The use of electrical insulation with improved flammability, smoke, and gas-emission characteristics would reduce the hazards to rapid transit systems.

Before selecting a flammability test method, criteria applicable to the selection were identified and assigned weighting factors. A total of 20 existing test methods from 17 different specifications were reviewed to determine how well each of them met the selection criteria. Some of the tests required that the specimen be positioned vertically, others that it be horizontal, and still others that it be at some angle such as 45 degrees. It was resolved that both horizontal and vertical flammability tests would be performed on the samples tested in this program. The vertical flammability test selected was a revised version of UL STD 44, while the horizontal flammability test selected was a revised version of ASTM D-470. All test specimens were preconditioned in a controlled environment for a minimum of 24 hours prior to the tests. Horizontal test specimens were subjected to a dielectric test following the exposure to flame. Due to the large range of wire sizes tested, it was necessary to use two different sizes of burners in the flammability tests. The smaller, a Bunsen burner with an output of approximately 930 BTU/hour, was used on wires AWG 4 and smaller. The larger, a Fischer burner with an output of over 2,000 BTU/hour, was used on wire larger than AWG 4. Pass/fail criteria were selected for the tests.

Smoke from burning materials within a transit system contributes to two main problems: obscuration of escape paths and exits, and incapacitation and/or suffocation due to insufficient oxygen or the toxic effect of fumes. Several methods have been devised to quantitatively measure smoke produced by a burning material. However, none were designed specifically for measuring and analyzing smoke produced from insulation on electrical wire caused by externally applied or internally generated heat. It was thus necessary to do considerable laboratory testing to evolve a suitable test. Selection criteria were identified and weighting factors assigned. Nine existing test methods were reviewed and compared to the criteria. The existing NBS test for wire uses a 3- by 3-inch comb upon which 10 feet of AWG 20 wire is wrapped. Another method was necessary to test larger sizes of wire in the NBS chamber. Two methods were evolved and used. One compared the specific optical density (D_s) of different wire sizes using the surface area equivalent to 10 feet of AWG 20 wire. The other compared the D_s of different sizes of wire using the insulation mass equivalent to 10 feet of AWG 20 wire. Wire AWG 10 and smaller was cut in one continuous length. Sizes AWG 8 through 4/0 were cut in 3-inch

lengths to fit into the NBS sample holder. Insulation was removed from MCM-sized cables and was cut in 3- by 3-inch squares to fit into the holder. All specimens were conditioned at 50 percent relative humidity and 72⁰F for a minimum of 24 hours. The NBS test duration was 20 minutes. Pass/fail criteria were selected for the test.

Initially Boeing was to sample the gases emitted during smoke tests. This approach was abandoned in favor of a separate DOT/TSC contract awarded to CAMI to conduct such tests on small animals (see addendum). The safety of the passengers in a transit vehicle in the event of a fire often depends upon the continued functioning of certain systems which in turn depend on the integrity of the wire insulation. Criteria for selecting the most appropriate method for testing wire and cable for circuit integrity were tabulated. Test methods were selected or derived for both single and multiconductor wire and cable. Pass/fail criteria were not derived.

Wire and cable samples were requested from all manufacturers who had given any indication of interest in the program. Specific insulation materials were not requested, only state-of-the-art or advanced materials. This approach resulted in several materials not being included that are currently being used by the transit industry. When this deficiency became apparent, the APTA Advisory Board obtained samples insulated with materials currently in use. Altogether, 83 single conductor wires and 21 multiconductor cables were received for testing.

Most of the samples were tested for flammability, smoke emission, and circuit integrity. Additional tests were performed on some samples. Scrape-abrasion-resistance tests were performed on all single conductor samples AWG 4 and smaller. Surface-resistance tests were performed on all single conductor wires submitted. Fluid-immersion tests were performed with nine fluids on a few selected materials. Dielectric tests were performed on all single conductor samples smaller than 500 MCM. Dynamic cut-through tests were performed on all single conductor samples tested. A cold bend test was performed on all samples except three.

Smoke emission tests were conducted on all samples of adequate quantity, and the specific optical density was computed. The duration of the NBS smoke test is 20 minutes, during which the specific optical density generally reaches its maximum and begins to decrease. The average specific optical densities for three test specimens of each sample were then averaged with like materials. The maximums (D_m) and values at four minutes ($D_s(4)$) were compared. As explained earlier, for wire sizes larger than AWG 20, tests were performed using both equivalent insulation surface area and equivalent insulation mass. These values were averaged to get a value for a specific wire size.

The materials are ranked as low, medium, and heavy smoke producers by the criteria previously discussed and established for values of D_m . Pass/fail criteria were not established on the basis of $D_s(4) < 10$ (low smoker), $D_s(4)$ 10 to 50 (medium smoker), and $D_s(4) > 50$ (heavy smoker). The rankings and categories are shown in Table S-1.

Table S-1. Ranking of Materials by Smoke Emission

Rank	$D_s(4)$ /Material	Category	D_m /Material
1	Teflon (PTFE)	<10 Low <50 Smokers	Teflon (PTFE)
2	Asbestos		Kapton
3	Kapton		Asbestos
4	Teflon (FEP)		Teflon (FEP)
5	Polyimide Coated Tefzel		Polyimide Coated Tefzel
6	Mica	50 Medium to Smoker 150	Mica
7	Halar	10 to Medium 50 Smokers	Tefzel
8	Tefzel		EPR
9	Silicone Rubber		Halar
10	EPR	>50 Heavy >150 Smokers	Silicone Rubber
11	Polyethylene		Polyester
12	Polyester		Polyethylene
13	Polyolefin		Polyolefin
14	Polyvinyl Chloride		Polyvinyl Chloride

In the ensuing commentary and discussion, various names of materials will be mentioned. However, it cannot be emphasized too strongly that materials with the same generic name do not all behave the same in a flame environment. Each insulation product should be tested to demonstrate its capabilities.

The results of the flammability tests of individual wires were averaged together where possible. Some were not of the same construction but had the same primary insulation. A method of numerical evaluation was derived, which includes a numerical value for ignition time, afterflame and glow time, conveyance of flame, and dielectric strength (after horizontal test only).

The general insulation materials for single conductor wire were ranked for flammability as follows:

- | | |
|----------------|--------------------|
| 1. Asbestos | 8. EPR |
| 2. Kapton | 9. Silicone Rubber |
| 3. Mica | 10. PVC |
| 4. Teflon | 11. Polyester |
| 5. EPR/Hypalon | 12. Polyolefin |
| 6. Halar | 13. Thermoplastic |
| 7. Tefzel | 14. Polyethylene |

Again, caution should be exercised because some of these rankings were based on a single wire sample.

Eleven of the 21 multiconductor cables submitted were considered comparable and thus tested for comparison and ranking. The ranking based on flammability test results was as follows:

- | | |
|-------------------------------|---|
| 1. Kapton/Kapton | 7. Silicone Rubber/Glass Braid |
| 2. Synthetic Rubber/Neoprene | 8. Halar/Halar |
| 3. Teflon (FEP) - Mica/Teflon | 9. Polyolefin/Polyolefin |
| 4. Polyethylene/Polyethylene | 10. Synthetic Rubber (Proprietary)/
Neoprene |
| 5. Polyethylene/Neoprene | |
| 6. Tefzel - Mica/Tefzel | 11. Polyolefin/Polyolefin |

Again, it should be noted that these data were gathered from test results of as few as one to three samples of some materials.

Circuit integrity tests were performed on all single conductor samples AWG 8 and smaller and on all multiconductor cables. Since the tests measure time to failure during a flame condition, the performance of a wire is based on a comparison of failure times. Wires insulated with silicone rubber outperformed all other materials from a circuit integrity point of view. It should be noted that silicone rubber must have a supporting member such as a fiberglass braid jacket to be a successful material. Ranking of materials based on single conductor circuit integrity tests are shown below

RANK	MATERIAL	RANK	MATERIAL
1.	Silicone Rubber	9.	Teflon
2.	Mica	10.	Tefzel
3.	Asbestos	11.	Polyvinyl Chloride
4.	EPR/Hypalon	12.	Halar
5.	EPR	13.	Thermoplastic
6.	Polyolefin	14.	Thermoplastic/Nylon
7.	Kapton	15.	Polyester
8.	Teflon/Asbestos	16.	Polyethylene

All of the multiconductor cables were similarly exposed to flame and are listed in order of their failure times except the first three, which had not failed in 30 minutes (1,800 seconds) of flame exposure when the test was discontinued.

1.	2-2X16-1	Silicone Rubber/Silicone Rubber
2.	A6-4X12-1	Silicone Rubber/Mylar/Glass Braid
3.	A2-19X12-1	Tefzel/Neoprene
4.	A3-7X14-1	EPR/Neoprene
5.	A3-7X14-2	Synthetic Rubber*/Neoprene
6.	A7-24X19-5	Polyethylene/Polyethylene/PVC
7.	A5-MX19-5	Polypropylene/Polyethylene/PVC
8.	4-7X12-2	Polyethylene/Neoprene

*Proprietary compound

9.	13-7X14-1	Mica-Teflon (FEP)/Teflon (FEP)
10.	A3-7X14-5	Polyolefin/Polyolefin
11.	4-7X12-1	Polyethylene/Polyethylene
12.	13-7X14-2	Mica-Tefzel/Tefzel
13.	6-7X12-1	Polyolefin/Polyolefin
14.	13-7X12-3	Kapton/Kapton
15.	A7-6X19-4	Polyethylene/PVC
16.	A3-7X14-4	Halar/Halar
17.	A2-6X19-4	Polyethylene/Shield/Polyethylene
18.	10-3X16-1	Tefzel/Shield/Tefzel
19.	3-7X20-2	Kapton/(No Jacket)
20.	3-7X20-1	Tefzel-Polyimide/(No Jacket)

It should be noted that the first 13 samples listed above did not fail until after five minutes. Silicone rubber again performed well, but there are several cables that have heavy jackets of Neoprene and PVC that also performed well.

Scrape-abrasion tests were performed on all single conductor samples AWG 4 or smaller received in adequate quantity. Thirty-one percent of the 64 samples tested failed. Materials used in the construction of the insulation barrier appear to have a significant effect on circuit integrity. Polyolefin appears to be the best overall performer, followed by Teflon (PTFE), Tefzel, Kapton, silicone rubber, PVC, polyester, and polyethylene.

Insulation resistance was measured on single conductor samples. Eighteen percent of the samples failed to meet the 2,500 megohm per 1,000 feet minimum. Failing specimens were predominantly insulated with PVC and silicone rubber. The better performers were Teflon, Tefzel, polyolefin, and Kapton.

Surface resistance measurements were made on the majority of the single conductor samples received. Approximately 7 percent failed to meet the 5 megohm-inch minimum. The better performers were polyester, polyolefin, polyethylene, Kapton, Teflon, Tefzel, and PVC.

Nineteen samples were selected for the fluid immersion tests. An attempt was made to subject as many different materials to the fluid as practical. Two different constructions using silicone rubber were complete failures in gasoline and trichloroethylene. Swelling was evident on samples insulated with EPR, Hypalon, and silicone rubber in both of these fluids. A sample of PVC exhibited 30 percent swelling and two samples of polyolefin approximately 10 percent each after immersion in trichloroethylene. One sample of Kapton with a Nomex braid failed the "3 kV-60 second hold" test after immersion in both ethylene glycol and trichloroethylene. All other materials appeared acceptable.

Dielectric strength tests were performed on 71 samples but little could be gained from the results because the thickness of the materials varied considerably and a large number of them were made of a composite of materials. Six percent of the samples failed an arbitrary minimum standard of acceptability. The minimum was 25 percent of the average of all those samples of the same wire size. The better performers were silicone rubber when jacketed with a fiberglass braid, some Kaptons, Tefzels, polyolefins, asbestos, and mica.

All samples passed the cold bend test without visible damage.

A stated objective of the program was to rank the materials according to their performance in a fire environment. The criteria for the ranking of the wire and cable insulating materials selected were flammability, smoke emission, and circuit integrity. Each of these has a different degree of importance, and weighting factors were assigned: flammability 0.30, smoke emission 0.47, and circuit integrity 0.23. If these values do not appear to be realistic to the reader, he/she is invited to revise them suitably and go through the exercise described in the text and determine their own ranking. Using the weighting factors and normalized performance factors, the materials can be ranked as shown in tables S-2 and S-3. Once again, it is of utmost importance to bear in mind that some of the data used to determine this ranking were obtained from as few as one or two samples of a particular material. All materials of the same generic name do not perform the same in a flame situation; thus, a material must prove itself by test and not be considered acceptable because

the manufacturer indicates that it is made of or contains asbestos, mica, Kapton, or some other highly ranked material. On the other hand, because the construction contains PVC, polyolefin, polyethylene, or another material that did not rank high, it should not be rejected without a fair test.

Table S-2. Ranking of Single Conductor Materials

Insulation Material	Ranking						
	Flammability	Smoke Emission		Circuit Integrity		Overall Ranking	
		After 4 Min.	D_m (Maximum)	4 Min. Base	20 Min. Base	4 Min. Base	20 Min. Base
Asbestos	1	1	3	3	3	1	1
Mica	3	5	5	2	2	2	2
Kapton	2	3	2	6	6	4	3
Teflon (PTFE)	4	2	1	7	7	5	4
Tefzel (Polyimide Coated)	7	4	4	9	9	7	5
Silicone Rubber	8	8	9	1	1	3	6
Tefzel	6	7	6	8	8	6	7
EPR	9	9	7	4	4	9	8
Halar	5	6	8	11	11	8	9
Polyester	11	11	10	12	12	10	10
Polyethylene	13	10	11	13	13	11	11
Polyolefin	12	12	12	5	5	12	12
PVC	10	13	13	10	10	13	13

Table S-3 Ranking of Multiconductor Cables

Cable Insulation Description	Ranking						
	Flamm- ability	Smoke Emission		Circuit Integrity		Overall Ranking	
		After 4 Min.	D_m (Maximum)	Using 4 Min. Base	Using 20 Min. Base	4 Min. Base	20 Min. Base
Teflon (FEP)-Mica/Teflon	3	1	2	*1	4	2	1
Kapton/Kapton	1	2	1	2	9	1	2
Synthetic Rubber/Neoprene	2	9	5	*1	*1	7	3
Silicone Rubber/Glass Braid	7	5	4	*1	*1	4	4
Synthetic Rubber/Neoprene	10	10	8	*1	2	9	5
Halar/Halar	8	3	3	*3	10	5	6
Tefzel-Mica/Tefzel	6	4	7	*1	7	3	7
Polyethylene/Neoprene	5	8	9	*1	3	8	8
Polyolefin/Polyolefin	11	7	6	*1	5	10	9
Poyethylene/Polyethylene	4	6	10	*1	6	6	10
Polyolefin/Polyolefin	9	11	11	*1	8	11	11

① Proprietary Compound

*Exceed Base Time

CONTENTS

1.0	INTRODUCTION	1
2.0	TYPICAL SYSTEM CONFIGURATION	3
2.1	The Vehicle	3
2.2	Wayside and Track Installations	6
3.0	ORIGINS OF FIRES AND PROBLEM AREAS	8
4.0	TEST METHODS DEVELOPMENT	11
4.1	Flammability Test Methods	11
4.1.1	Approach	11
4.1.2	Test Selection Criteria	11
4.1.3	Analysis of Existing Test Methods	12
4.1.4	Selection of Flammability Test Methods	22
4.1.5	Flammability Test Procedures	24
4.1.6	Pass/Fail Criteria	36
4.2	Smoke Test Methods	40
4.2.1	Approach	40
4.2.2	Test Selection Criteria	41
4.2.3	Analysis of Existing Test Methods	42
4.2.4	Selection of Smoke Emission Test Method	45
4.2.5	Smoke Emission Test Procedure	54
4.2.6	Pass/Fail Criterion	55
4.3	Toxicity Test	56
4.4	Circuit Integrity Test Methods	56
4.4.1	Approach	57
4.4.2	Test Selection Criteria	57
4.4.3	Analysis of Existing Test Methods	58
4.4.4	Selection of Test Methods	60
4.4.5	Circuit Integrity Test Procedures	61
4.4.6	Circuit Integrity Pass/Fail Criteria	66
5.0	TEST PROGRAM	68
5.1	Test Samples	68
5.2	Test Sample Identification	70
5.3	Flammability Tests	74
5.3.1	Burner Considerations	74
5.3.2	Vertical Flammability Test	82
5.3.3	Horizontal Flammability Test	83
5.4	Smoke Tests	84
5.5	Circuit Integrity Tests	86
5.6	Additional Wire and Cable Evaluation Tests	88
5.6.1	Scrape Abrasion Resistance Test	88
5.6.2	Insulation Resistance Test	89
5.6.3	Surface Resistance Test	90
5.6.4	Fluid Immersion Tests	93
5.6.5	Dielectric Tests	94
5.6.6	Dynamic Cut-Through Test	95
5.6.7	Cold Bend Test	95
6.0	TEST RESULTS AND ANALYSIS	97
6.1	Flammability Test Results	97
6.2	Smoke Test Results	121
6.3	Circuit Integrity	140
6.3.1	Single Conductor Wires	140

CONTENTS (Continued)

6.3.2	Multiconductor Cables	143
6.4	Results of Additional Performance Evaluation	150
6.4.1	Scrape Abrasion Resistance Test Results	150
6.4.2	Insulation Resistance Test Results	156
6.4.3	Surface Resistance Test Results	156
6.4.4	Fluid Immersion Test Results	168
6.4.5	Dielectric Strength Test Results	170
6.4.6	Dynamic Cut-Through Test Results	177
6.4.7	Cold Bend Test Results	177
6.5	Dimension Measurements	180
7.0	RANKING OF MATERIALS	185
7.1	Fire Environment	185
7.1.1	Single Conductor Wires	185
7.1.2	Multiconductor Cables	189
7.2	Ranking of Materials Based on Additional Performance Tests	192
8.0	CONCLUSIONS	193
9.0	RECOMMENDATIONS	196
APPENDIX A	METHOD OF PERFORMING COMPARATIVE ANALYSIS	198
APPENDIX B	ANALYSIS OF EXISTING SMOKE TEST METHODS	209
APPENDIX C	IEEE-383-1974 TEST METHOD	217
APPENDIX D	INVENTIONS	220
ADDENDUM:	CAMI EXECUTIVE SUMMARY OF DOT/TSC CONTRACT No. RA-77-15, INHALATION TOXICITY OF THERMAL DEGRADATION PRODUCTS FROM ELECTRICAL INSULATION	221

FIGURES

2-1	Typical Rapid Transit Systems Wire and Cable Installation	4
2-2	Pickup Shoe Mounted on Fiberglass Standoff	4
2-3	Typical Tunnel Installation	6
2-4	Third Rail Connection Details	6
2-5	Methods of Installing Wire and Cable in Tunnels	6
2-6	Typical Underground Installation of Wire and Cable	7
4-1	Vertical Flammability Test Setup	26
4-2	Vertical Flammability Test Data Sheet	29
4-3	Large Gauge Wire Flammability Test Setup	31
4-4	Horizontal Flammability Test Setup	35
4-5	Contact Plate Jig for Postflame Dielectric Test	37
4-6	Horizontal Flammability Test Data Sheet	38
4-7	NBS Aminco Smoke Chamber	47
4-8	Wire Comb	48
4-9	Mounting the Test Specimen	48
4-10	Smoke Density Versus Length	50
4-11	Smoke Density Versus Surface Area	51
4-12	Smoke Density Versus Insulation Mass	52
4-13	Smoke Density Versus Conductor Mass	53
4-14	BIW Circuit Integrity Test Setup	59
4-15	MIL-W-25038 Circuit Integrity Test	60
4-16	Single Conductor Wire Circuit Integrity Test Data Sheet	63
4-17	Multiconductor Cable Flammability/Integrity Test Setup	65
4-18	Failure Detection Circuitry	65
4-19	Multiple Conductor Cable Circuit Integrity Data Sheet	67
5-1	Test Burner and Plate Setup	81
5-2	10 Feet of AWG 20 Mounted	85
5-3	3 Inch Lengths of Larger Gauge Wire Mounted	85
5-4	Steel Mesh to Hold Insulation From Large Gauge Wire In Place	85
5-5	Calculations for Equivalent Surface Area and Insulation Mass Work Sheet	87
5-6	Scrape Abrasion Blade Details	88
5-7	Typical Surface Resistance Test Chamber	92
6-1	Flammability Test Data Sheet (Completed)	98
6-2	Typical Example Printed Smoke Test Results (Two Sheets)	125
6-3	Typical Example Graphical Smoke Test Results	127
6-4	Optical Density Plot Comparison (Silicone Rubber Insulated/ Polyolefin Jacket)	135
6-5	Optical Density Plot Comparison (Tefzel Insulated/Polyolefin Coated)	137
6-6	Optical Density Plot Comparison (Kapton Insulated)	138
6-7	Optical Density Plot Comparison (Polyolefin Insulated)	139
6-8	Optical Density Plot Comparison (Silicone Rubber Insulated/ Glass Braid Jacket)	141
6-9	Optical Density Plot Comparison (Teflon Insulated)	142

TABLES

4-1	Flammability Test Selection Criteria and Weighting Factors.	12
4-2	Flammability Test Summary—Horizontal Tests	15
4-3	Flammability Test Summary—Vertical Tests	17
4-4	Flammability Test Summary—Other Than Vertical and Horizontal	19
4-5	Wire Size Versus Flame Application	28
4-6	Wire Size Versus Vertical Flame Application Time	32
4-7	Wire Size Versus Horizontal Flame Exposure Time	34
4-8	Test Selection Criteria and Weighting Factors	42
4-9	Smoke Test Method Summary	43
4-10	Rating of Smoke Test Methods Versus Selection Criteria	46
4-11	Circuit Integrity Selection Criteria Weighting Factors	58
4-12	Wire Sizes and Corresponding Load Weights	62
5-1	Sample Suppliers/Manufacturers	69
5-2	Samples Requested	70
5-3	Single Conductor Samples Categorized by Wire Size	71
5-4	Single Conductor Samples Categorized by Insulation Material	72
5-5	Multiconductor Cable Samples	73
5-6	Supplier Identification Code	75
5-7A	Sample Descriptive Information, Single Conductor	77
5-7B	Sample Descriptive Information, Multiconductor Cable	80
5-8	Burner Statistics	82
5-9	Wire Size Versus Abrasion Tester Head	89
5-10	Wire Size Versus Mandrel Diameter and Load Weight	94
5-11	Wire Diameter Versus Mandrel Diameter	96
6-1	Flammability Test Results Categorized by Insulation Material— Single Conductor	100
6-2	Flammability Test Results—Multiconductor Cable	105
6-3	Flammability Test Results—Average of "Lumped" Materials, Wires AWG 4 and Smaller	108
6-4	Summation of Flammability Performance Factors	110
6-5	Flammability Evaluation—Single Conductor	112
6-6	Summary of Lumped Factors, Wires AWG 4 or Smaller	116
6-7	Multiconductor Cable Flammability Test Comparison	122
6-8	Multiconductor Cable Flammability Ranking	124
6-9	Specific Optical Density Test Results	129
6-10	Insulation Type Versus Average Specific Optical Density (D_s) at 4 Minutes	130
6-11	Insulation Type Versus Maximum Specific Optical Density (D_m)	131
6-12	Insulation Materials in Ascending Order of Smoke Emission at 4 Minutes	133
6-13	Insulation Materials in Ascending Order of Smoke Emission	134
6-14	Circuit Integrity Test Results—Single Conductor Wire AWG 8 and Smaller	144
6-15	Mean Time to Failure Versus Material and Gauge Size AWG 8 and Smaller	147
6-16	Circuit Integrity Test Summary	148
6-17	Circuit Integrity Test Results, Multiconductor Cable	149
6-18	Scrape Abrasion Resistance Test Results	152
6-19	Scrape Abrasion Resistance Test Results, Better Performers	155

TABLES (Continued)

6-20	Ranking of Materials Based on Scrape Abrasion Resistance	157
6-21	Insulation Resistance Test Results	158
6-22	Ranking of Materials Based on Insulation Resistance	162
6-23	Surface Resistance Test Results	163
6-24	Surface Resistance Test Results	169
6-25	Ranking of Materials Based on Surface Resistance	169
6-26	Fluid Immersion Test Results, Dielectric Test 3kV- 60 Second Hold	171
6-27	Fluid Immersion Test Results- Swelling of Insulation Material (O.D. Change %)	172
6-28	Fluid Immersion Test Results- Dielectric Breakdown (kV)	173
6-29	Dielectric Strength Test Results Summary	174
6-30	Dielectric Strength Test Results	175
6-31	Dynamic Cut-Through Results	178
6-32	Ranking of Material Based on Dynamic Cut-Through Test	180
6-33	Dimensional Measurements, Single Conductor Wires	181
6-34	Dimensional Measurements, Multiconductor Cables	183
7-1	Material Ranking Criteria Weighting Factors	186
7-2	Normalized Performance Factors for Materials to be Ranked	186
7-3	Ranking of Single Conductor Wires	188
7-4	Ranking of Insulation Materials	189
7-5	Normalized Performance Factors- Multiconductor Cables	190
7-6	Ranking of Multiconductor Cables	191
7-7	Ranking of Multiconductor Cable Insulations	192
A-1	Example of Assignment of Weighting Factors to Selection Criteria	200
A-2	Assignment of Weighting Factors to Flammability Test Selection Criteria	200
A-3	Assignment of Weighting Factors to Smoke Test Selection Criteria	201
A-4	Assignment of Weighting Factors to Circuit Integrity Test Selection Criteria	201
A-5	Smoke Test Method Selection- Candidate Methods Versus Smoke Density Measurement Capability	202
A-6	Smoke Test Method Selection- Candidate Test Methods Versus Repeatability	203
A-7	Smoke Test Method Selection- Candidate Test Methods Versus Ability to Test All Sizes and Constructions	204
A-8	Smoke Test Method Selection- Candidate Test Methods Versus Existing Wire Test Methods	205
A-9	Smoke Test Method Selection- Candidate Test Methods Versus Cost of Test	206
A-10	Smoke Test Method Selection- Candidate Test Methods Versus Simplicity	207
A-11	Smoke Test Method Selection- Candidate Test Methods Versus Simulation of Fire	208



1.0 INTRODUCTION

The hazard of fire has long been a concern to the transportation industry. In recent years, attention has been focused on the effects of smoke produced from burning or smoldering rather than on the immediately apparent effects of toxic gases, the area previously of interest. Recent studies have shown that incapacitation or death from smoke is more probable than from fire. In the crowded, confined environment of a rapid transit vehicle, it is essential that smoke emission from all sources be minimized. Criteria for the amount of smoke that can be tolerated and standard methods for measuring smoke emission need to be established.

The problem of an "allowable" quantity of smoke is compounded by the possibility of toxic fumes in the smoke. The use of halogenated monomers as flame retardants in the basic polymer chain brings with it the problem of the emission of hydrogen-halogenated gases as well as halogenated compounds. It is extremely difficult to categorize wire and cables in this respect because of the different gases and compounds formed at different combustion, smoldering, or current-overload-induced temperatures. Standard criteria and test methods are required to properly characterize the toxic gas evolution properties of electric wire and cable.

Another problem in the selection of flammability and smoke emission criteria is that the integrity of the wire and cable must be maintained in circuits that are essential for the continued safety of the passengers and vehicle during and after a fire. Some of the insulations used to reduce flammability and smoke emission problems char or even melt and fall off the conductor. Currently, no criteria or test methods exist to guide wire and cable manufacturers, vehicle manufacturers, or transit authorities.

None of these problems are insurmountable. The Urban Mass Transportation Administration (UMTA), working through the Transportation Systems Center, recognized these problems and also recognized that the adoption of test standards and guidelines for wire and cable used in rapid transit vehicles must be undertaken in an organized, well-coordinated program in which flammability, smoke emission, toxic gas evolution, and critical circuit integrity are treated as interrelated components of a system. As a result, UMTA competitively awarded contract DOT-TSC-1221, "Electrical Insulation Fire Characteristics," to the Boeing Commercial Airplane Company in July 1976. A

separate contract was awarded to the American Public Transit Association (APTA) to support the Transportation Systems Center and to bring to this work their knowledge and experience.

The objective of the program was "to determine whether any of the currently used electrical insulations can provide a fire safe environment in terms of very low flame propagation, smoke and toxic gas evolution... and determine whether any of these can meet criteria which will be established by taking into account the fire hazards inherent in transit systems."

The Electrical Insulation Fire Characteristics Project began in July 1976 and was completed in July 1978. This report represents the results of the test program.

2.0 TYPICAL SYSTEM CONFIGURATION

A rapid transit system powered by externally generated electricity which operates in both underground and surface environments was selected as the baseline model for the study. The reasons for this selection are as follows:

- Greatest usage of electrical wire and cable
- Greatest variation of type, construction, and insulation of materials
- Effect of operating environment on safety
- Results will be directly applicable to all other modes of transportation.

For the purpose of this discussion, the rapid transit system model will be treated as having two components: the vehicle(s), and the wayside and track installation. Each of these components is illustrated in Figures 2-1 through 2-6 and is discussed in general terms below. It should be noted that the figures depict a general model and are not intended to propose or favor any specific design or configuration.

2.1 The Vehicle

Figure 2-1 illustrates the usage and disposition of the vehicle wiring and shows in Figure 2-1c that the power for the vehicle is provided at the interface between the pickup shoe and the third rail. This pickup shoe assembly is a potential source of fire - the shoe, which is normally a metallic contact mounted on an insulator (wood, molded fiberglass, plastic), becomes covered with contamination which eventually carbonizes and burns as a result of the energy from the arcing which takes place between the shoe and the third rail. Therefore the vehicle maintenance program has to include regular cleaning of the pickup shoe assembly.

Figure 2-2 illustrates a typical pickup shoe which is designed to minimize this problem. From the pickup shoe the power is conveyed to the traction motor via a braided conductor and a heavy duty stranded insulated conductor. Power is also supplied to control circuits, lighting circuits, air conditioning fans, and door open-and-close circuits. As illustrated in Figure 2-1, the car designers make every attempt to minimize the safety hazard resulting from any fire or

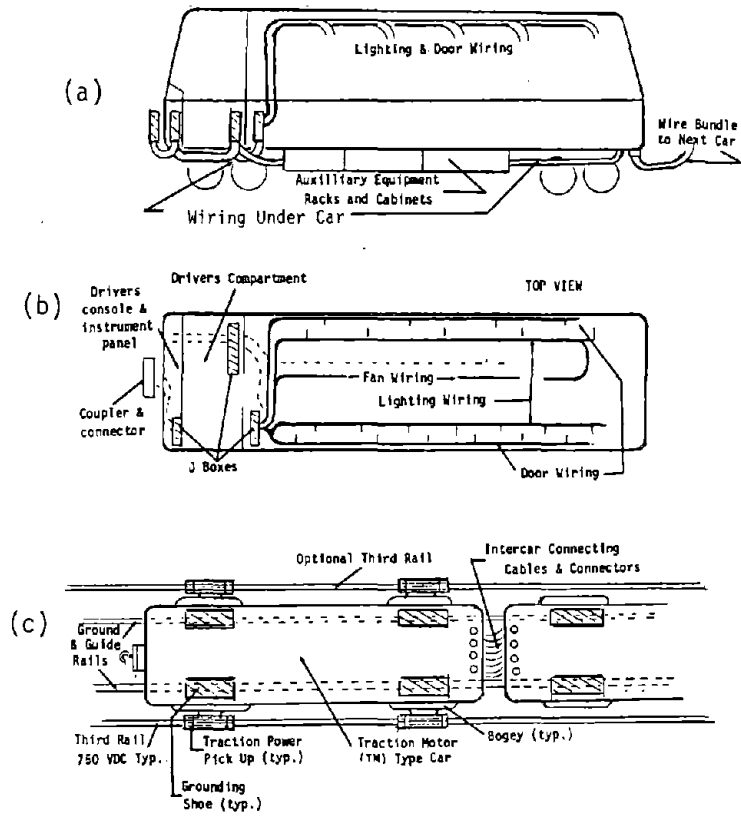

FIGURE 2-1 TYPICAL RAPID TRANSIT SYSTEMS WIRE AND CABLE INSTALLATION

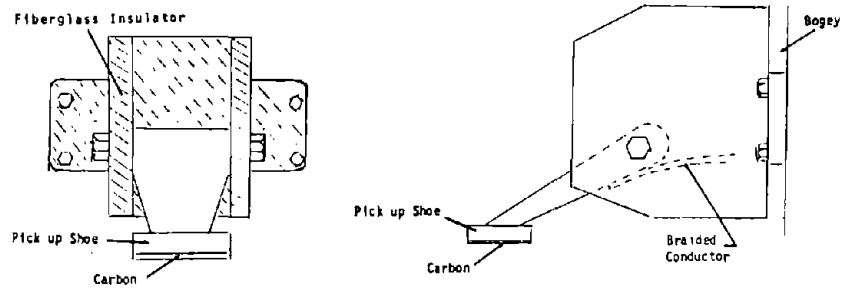

FIGURE 2-2 PICKUP SHOE MOUNTED ON FIBERGLASS STAND OFF

smoke emanating from the wire and cable by routing it under the floor of the passenger compartment. Only those wires required for lighting, doors, and public address are routed through the compartment. The drawback of this approach, however, is that it requires a heavy durable insulation to survive the severe environment external to the passenger compartment. Heavy durable insulation usually means more, thicker layers of insulation which can mean more smoke, flame, and toxic gases.

Traction motor wiring takes the most expeditious route from the pickup to the motor but is usually routed separately from other wiring. Signal and low power wiring is routed in bundles. Most wire bundles are protected by installation techniques which use the car structure for protection or by routing in protective channels installed especially for the purpose. Safety precautions such as the use of fuses are employed in addition to the external routing of the wire. The fuses are normally located in junction boxes located in the operator's compartment.

Since rapid transit systems usually operate a series of vehicles in the form of a train, the communication between the trains can be by one of two methods, (a) a series of cables or (b) a connector. Again, the cables have to survive an extremely arduous environment and therefore contain a considerable amount of fuel for any potential fire.

Approximately 15 to 20 thousand feet of wire and cable is now being used per car. For the majority of cars now in service, a large percentage of this wire and cable is neoprene or rubber jacketed cross-linked ethylene propylene. Some of the vehicles just coming into service use large amounts of Tefzel and Halar insulated wire and cables. The voltage ratings of the wire range from 2.5 kilovolts for high voltage (traction motor) circuits to 600 volts for control circuits. The sizes of the individual wires range from 1000 MCM to 16 AWG.

In general, there are no governmental or regulatory constraints on the electrical wiring installation design for rapid transit vehicles or for the selection of wire and cable to be used on these vehicles. At present, there are a variety of criteria for selecting wire and cable.

2.2 Wayside and Track Installations

Typical wayside and track installations are shown in Figures 2-3 through 2-6.

In most cases, traction power is supplied from a single third rail located on the far side of the track from the platform or tunnel walkway. In some systems two third rails are used. Traction power ranges from 600 to 1000 volts dc. This power is fed from the rectifying station via lined concrete ducts buried under the track bed. Most of the wire used for traction power is 1000 volt rated 2000 MCM and is of the neoprene or rubber jacketed ethylene propylene insulated variety. Figure 2-3 illustrates a typical track installation.

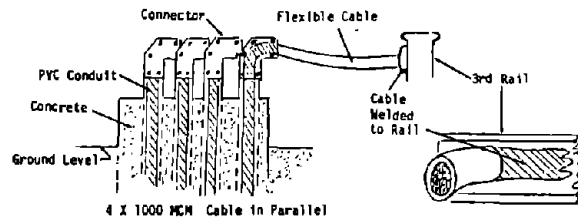
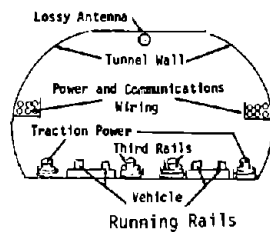

FIGURE 2-3 TYPICAL TUNNEL INSTALLATION FIGURE 2-4 THIRD RAIL CONNECTION DETAILS

Figure 2-4 illustrates one method by which the traction power is connected to the third rail. Numerous other wires and cables are installed in the tunnels and stations to provide power for lights and ventilating fans and to carry train command and control information, and communications. Figure 2-5 shows various methods of routing the wire in the tunnels. Figure 2-6 shows a typical installation that will run all wires in lined ducts embedded in concrete. This system has safety advantages in that a fire in one wire or cable cannot propagate to another, and flame and smoke will be contained, thereby minimizing the effect of an incident on the passengers.

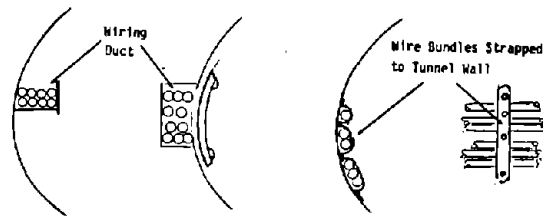

FIGURE 2-5. METHODS OF INSTALLING WIRE AND CABLE IN TUNNELS

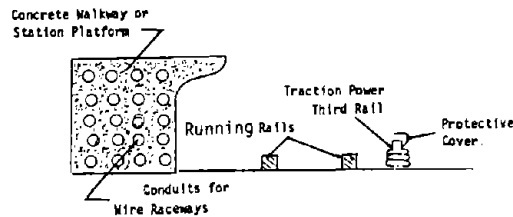

FIGURE 2-6. TYPICAL UNDERGROUND INSTALLATION OF WIRE AND CABLE

Other safety features are exemplified by the Washington Metropolitan Area system. The passenger stations are air conditioned and the tunnels are ventilated. Tunnel ventilating fans located in shafts between stations can serve as an emergency exhaust system and are connected to the essential power system. The fans can move air in either direction. In an emergency, the vent shaft louvers can be closed and air moved from the station area to the fan shafts and exhausted. Smoke and fumes caused by the emergency will thus be removed from public areas. In case of conditions requiring smoke flow to be in the opposite direction, the fans can be reversed. Fans are also used to exhaust heat generated by the trains, from beneath the station platform. Smoke and heat detectors are installed in all tunnels and stations. However, these fans and smoke and heat detectors are dependent on the integrity of the electrical wire and cable in order to perform their intended function in a hostile environment. The majority of the wiring presently installed on the walls of stations and tunnels is rubber or neoprene jacketed ethylene propylene.

In general, standard building codes and electrical codes are applied to the construction of tunnels and stations. The criteria for the selection of wire and cable for wayside and track installations is similar to that for vehicles.

3.0 ORIGINS OF FIRES AND PROBLEM AREAS

The following case histories can be used to postulate the typical origins of fires:

- Chicago Transit Authority (CTA) had a fire of major proportions caused by a piece of steel (flash) from the rail that came off, lodged in the vehicle truck, and shorted out the traction power. This may or may not be an isolated case and has little to do with the actual wire insulation. However, if it is a frequent happening, perhaps the electrical parts in the truck area should be protected by some specially designed shroud.

- New York City Transit Authority (NYCTA) describe their history of electrically involved fires as follows:

Electrical fires in the NYCTA subway system usually have two sources of ignition. The first cause is debris external to the vehicle. The nature of the subway system precludes keeping the trackways completely free at all times of debris. The debris is moved through the tunnel by the action of passing trains. At times, power cables feeding traction power to the third rail block the free movement of debris, and an accumulation of debris occurs. Arcing from the contact shoe of a passing train is enough to ignite the debris and cause the nearby cable to burn. The second cause of electrical fire is due to a cable fault. Some locations in the subway system are damp, and on occasion, water seeps into the cable causing a ground fault; it is possible that currents will be high enough to vaporize the conductor. The heat involved in this fault will cause the insulation to burn.

In the past six years, the Transit Authority has had four electrical fires that can be considered of major proportion. In all of these instances, there was only one death. A woman died of an apparent heart attack during a fire in a subway tunnel. This woman had a history of heart problems, and there is no evidence that her death was caused directly by the effects of the fire. In all instances, there were passengers treated for smoke inhalation.

Property damage, in all cases, was localized and did not cause extensive damage to the system.

- Montreal claims that there were no major incidents due to electrical system faults.
- Paris - disregarding the serious accident of 1903 - has had only two important fires. Some garbage fires have occurred but without repercussions. No deaths have resulted - only smoke inhalation. Fire fighters have only been hampered by smoke in tunnels.
- Port Authority of NY and NJ report that fires have been caused by "short circuits" and "grounds". Damage has been caused to property, but no deaths have resulted.
- Southeastern Pennsylvania Transportation Authority (SEPTA) reported that electrically involved fires on feeders are very rare. Those that occur are generally a result of insulation failure due to the end of its life or damage from external causes, such as damage caused at the time of installation. Most damage is confined to the cable itself. Property damage has been minimal and no deaths have occurred.
- Boston indicated that they had fires or potential fire situations in/with
 - Battery boxes - PCC cars
 - Insulation blocks - Bluebird cars
 - Cable fires - Kendall Station
 - Trolley wire down on car - Kenmore Station

One death has been attributed to the above.

It is difficult for fire fighters to reach a fire between stations, in tunnels or on elevated structures. Problems of extinguishing a fire may be due to lack of lighting, dense smoke, and lack of water. The following corrective action has been taken: (a) dry water pipes have been installed in the tunnels, (b) two-way radios have been installed in the cars, (c) auxiliary lighting circuits have been installed.

Fire fighters refuse to take action to combat fires (i.e., enter tunnels, mount overhead structures, etc.) until all electrical power has been removed.

Electrical fires on transit cars most frequently occur around the third rail-collector shoe assembly. Arcing caused by third rail gaps, misaligned shoes, or ice or other debris on the track area can ignite flammable materials under the cars. Improved design of collector shoes, beams, third rail spacing, and electrical clearances under cars are being incorporated to reduce arcing.

Battery fires are usually traced to a poor match of the battery, charger, and load. The mismatch, coupled with inadequate maintenance, could result in fires. Adequate battery/charger capacity and good maintenance procedures can greatly reduce this cause of fire.

Braking resistors are subjected to extreme heat and sometimes are the causes of fires.

From the above comments it can be concluded that the situation could be improved if the susceptibility of the electrical insulation to fire and ignition sources were reduced, if the amount of smoke emitted by the electrical insulation during a fire situation were reduced, and if improvements could be made to the design and maintenance of the entire system. The scope of the program discussed in this report is limited to the first two problems, but it is the impression of the writers that system design improvements could be effected which would reduce the fires associated with electrical components.

4.0 TEST METHODS DEVELOPMENT

4.1 Flammability Test Methods

4.1.1 Approach

The technical approach selected for the development of the Flammability Test Methods was as follows:

- Identify the test selection criteria
- Assign weighting factors to these selection criteria
- Review candidate, existing and proposed methods
- Conduct research or development necessary to derive additional data
- Select the test method
- Validate the effectiveness of the test method by laboratory test.

This section of the report discusses all of the above tasks except the laboratory test phase, which is discussed later in Sections 5 and 6.

4.1.2 Test Selection Criteria

Prior to reviewing all known flammability test methods for wire and cable, the criteria applicable to the selection of the test were identified and assignment of weighting factors to them established. The following criteria were identified:

In general, the selected method should

- Be an existing method or a modification of an existing method.
- Provide repeatable results from test to test and from laboratory to laboratory.
- Be capable of testing a wide range of wire sizes, e.g., 20 AWG - 2000 MCM.
- Be low cost, i.e., should not require high cost test equipment/facilities and should not use large amounts of wire.
- Be simple to conduct.
- Simulate the installation.

In addition, the flammability test should provide a means of measurement of

- Ease of ignition
- Flame propagation
- Amount of falling molten droplets or burning pieces
- Extinguish time.

Not all of these criteria are of equal importance, so weighting factors were assigned as shown below by comparing each criteria against the other in a binary, with 1 for the winner and 0 for the loser basis. The method used to derive these weighting factors is discussed in Appendix A.

TABLE 4-1 FLAMMABILITY TEST SELECTION CRITERIA AND WEIGHTING FACTORS

Criteria	Weighting factor
Ignition, etc.	.250
Repeatability	.214
Existing method	.143
Any laboratory	.143
All sizes	.107
Cost	.107
Simplicity	.036
Simulate installation	0

4.1.3 Analysis of Existing Test Methods

A total of twenty existing tests from seventeen different specifications were reviewed to determine how well each of them meet the criteria. The candidate specifications are shown below:

Existing Flammability Tests

ASTM D 470-75 Standard Methods of Testing Thermosetting Insulated and Jacketed Wire and Cable

ASTM D 2220-74 Standard Specification for Poly (vinyl chloride) Insulation for Wire and Cable, 75⁰ Centigrade Operation

ASTM D 2633-76 Standard Methods of Testing Thermoplastic Insulated and Jacketed Wire and Cable

FAA, FAR 25.1359 Federal Aviation Administration, Federal Aviation Regulations; Part 25, Air Worthiness Standards: Transport Category Airplanes; Paragraph 25.1359, Electrical System Fire and Smoke Protection

IEEE STD 383-74 IEEE Standard for Type Test of Class IE Electric Cables, Field Splices and Connections for Nuclear Power Generating Stations

IPCEA-NEMA S19-81 (NEMA Pub. No. WC3-1969) Rubber Insulated Wire and Cable for Transmission and Distribution of Electrical Energy

IPCEA-NEMA S61-407 (NEMA Pub. No. WC5-1973) Thermoplastic Insulated Wire and Cable for the Transmission and Distribution of Electrical Energy

MIL-W-5086 Military Specification, Wire, Electric, Polyvinyl Chloride Insulated, Copper or Copper Alloy

MIL-W-8777 Military Specification, Wire, Electrical, Copper, 600-volt, 150⁰ Centigrade

MIL-W-16878 Military Specification, Wire, Electrical, Insulated, General Specification for

MIL-W-22759 Military Specification, Wire, Electric, Fluoropolymer - Insulated, Copper or Copper Alloy

MIL-W-81044 Military Specification, Wire, Electric, Crosslinked Polyalkene Insulated, Copper

MIL-W-81381 Military Specification, Wire, Electric, Polyimide-insulated, Copper or Copper Alloy

UL BUL 758	Underwriters' Laboratories Bulletin Factory Inspection Procedure, Flame-Retardant Properties
UL STD 44	Rubber-insulated Wires and Cables
UL STD 62	Flexible Cord and Fixture Wire
UL STD 83	Thermoplastic - Insulated Wires

The flammability specifications reviewed were of varying degrees of thoroughness, ranging from vague to good. A summary comparison of the test methods reviewed are contained in Tables 4-2, 4-3, and 4-4. Among the items that were vague, or not mentioned in some specifications, were the temperature (minimum or maximum) of the flame, the type of gas, the gas pressure, the enclosure dimensions and particulars, and the preconditioning of specimens prior to testing.

Generally, of the twenty test procedures reviewed, all were comparable in size except the IEEE-383, which is meant to test cables for installation in a nuclear power generating station and is of a much larger scale. The following comparisons will not consider their likeness/unlikeness to the IEEE test.

All of the tests reviewed require a chamber approximately 12 inches by 12 inches by 24 inches high, with one side and the top open. A Bunsen or Tirrill burner of 3/8 inch bore by 4 inches in length is also required.

Vertical tests require that the flame of the burner be 5 inches in height with a 1-1/2 inch inner blue cone. Most of the tests require a gummed Kraft paper tape flame indicator flag to be placed on the test specimen above the flame-specimen intersection point. Approximately half of the tests require a surgical cotton pad to be placed under the test specimen. Both the flag and pad are for determining if the test specimen conveys flame. The burner is to be oriented 20 degrees from the vertical (from the test specimen). Conditioning of the test specimens is only mentioned in UL 44. The flame is applied to the test specimen for 15 seconds and removed for 15 seconds, and this cycle is repeated for four additional times (5 cycles). This is true of all test procedures reviewed. The only deviation is that UL 44 requires that the test flame not be reapplied until all flaming or

Table 4-2. FLAMMABILITY TEST SUMMARY - HORIZONTAL TESTS

TEST NUMBER	PURPOSE	APPARATUS	SPECIMEN/CONDITIONING
<p>ASTM D470-75</p> <p>Procedure for testing thermosetting insulation and jacket compounds used on insulated wire and cable.</p>	<p>Chamber - 12" W x 14" D x 24" H Open Top & Front Burner - Tirrill 3/8" x 4" Gas - Ordinary Illuminating Flame - 5" with 1-1/2" inner cone Clock or Watch</p>	<p>No pretest conditioning required. Specimen - 10" long</p>	
<p>IPCEA-NEMA S-19-81 (NEMA PUB. NO. WC3-1969) Paragraph 6.13.2</p> <p>Testing of rubber-insulated wires and cables used for transmission & distribution of electrical energy for normal conditions of installation and service, either indoors, aerial, underground or submarine.</p>	<p>Same as ASTM D470-75</p>	<p>Same as ASTM D470-75</p>	
<p>MIL-W-5086 (METHOD I)</p> <p>For polyvinyl chloride insulated single conductor electric wires made with tin or silver-coated copper/copper alloy conductors. The insulation may be used alone or with other insulating or protective materials.</p>	<p>Chamber - 12" W x 12" D x 24" H Open top & front Burner - Bunsen type, 3/8" bore x 4" fitted with a wing top flame spreader with 2" x 1/16" opening Flame - Blue, 2" high Tissue - Facial tissue conforming to UU-T-450</p>	<p>No conditioning mentioned Specimen 10" in length</p>	
<p>MIL-W-8777 (PROCEDURE II)</p> <p>For single conductor copper wire with silicone primary insulation capable of continuous operation at a maximum conductor temperature of 200°C. For use in aircraft and missiles. The wires covered by this specification are not intended as fire-resistant wires.</p>	<p>Chamber - An enclosure which allows a flow of sufficient air for combustion but is free from drafts. Burner - Bunsen, 3/8" bore x 4" with 2" x 1/16" flame spreader Flame - 2" high all blue flame of 1600° F Optional - 2" flame with blue cone of 1/3 its height. Tissue - Facial tissue conforming to UU-T-450.</p>	<p>No conditioning mentioned. Specimen length not given</p>	
<p>UNDERWRITERS' LABORATORIES BULLETIN 758 Factory Inspection Procedure, Flame-Retardant Properties</p>	<p>Chamber - 12" x 12" x 24" - Open on top and one long side. (Orientation not clear - assume long side horizontal) Burner - Tirrill, 3/8" bore x 4" Gas - ordinary illuminating at normal pressure Flame - 2" with 1/3 inner cone Watch or clock</p>	<p>Specimen 20" in length marked 2", 7" and 13" from one end. No conditioning mentioned.</p>	

TABLE 4-2. CONTINUED

	PROCEDURE	REQUIREMENTS
ASTM D470-75	Suspend specimen horizontally between two supports 8" apart. Bring burner under specimen so that the tip of blue cone just touches specimen. Remove flame after 30 seconds.	Observe during or after flame application, whether specimen supporting flame extends beyond impingement area. Also note behavior and duration of flaming of specimen after the removal of the test flame.
IPCEA-NEMA S-19-81 (NEMA PUB. NO. WC3-1969) Paragraph 6.13.2	Same as ASTM D470-75	Same as ASTM D470-75
MIL-W-5086 (METHOD I)	Suspend specimen horizontally in test chamber. With the burner held vertically and flame spreader parallel to specimen, apply flame directly under center section of specimen for 15 seconds for wire sizes 10 and smaller and 30 seconds for sizes 8 and larger. Withdraw flame immediately at the end of the period. Suspend tissue 9 1/2" below specimen during test.	Record distance of flame travel in each direction on specimen, self-extinguishing time and presence/absence of flame in tissue. Ignore charred holes or spots in the absence of actual flame.
MIL-W-8777 (PROCEDURE II)	A specimen of sufficient length shall be suspended taut in a horizontal position. The burner shall be applied vertically directly under the center of the specimen for 15 seconds for wires of size 10 or smaller and 30 seconds for wires larger than size 10. The tissue shall be suspended 9 1/2" below the specimen.	Record the rate of flame travel and self-extinguishing time.
UNDERWRITERS' LABORATORIES BULLETIN 758	Specimen to be laid and held tautly horizontally on supports 18" apart. Bring vertical burner to specimen so that inner blue cone just touches 2" mark on underside for 30 seconds.	Observe to determine rate of burning of the sample within the marked 6" length during and after flame application, also note any falling burning particles.

TABLE 4-3. FLAMMABILITY TESTS SUMMARY - VERTICAL TESTS

TEST NUMBER	PURPOSE	APPARATUS	SPECIMEN/CONDITIONING
<p>UNDERWRITERS' LABORATORIES STD. 44 Test requirements for rubber-insulated single and multiple-conductor cables up to 2,000 MCM for use at potentials of 5,000 volts or less.</p>	<p>Chamber - 12"W x 12"D x 24"H Open Top & Front Burner - Bunsen or Tirrill 3/8" bore x 4" Flame - 5" with 1-1/2" cone 1500°F or higher Gummed Kraft paper flame indicator Surgical Cotton Pad Wood Wedge to tilt Burner 20° from the vertical</p>	<p>Specimen 18" in length Half are aged 168 hrs. at 250°F</p>	
<p>UNDERWRITERS' LABORATORIES STD. 62 For flexible cord and fixture wire.</p>	<p>Chamber - 12"W x 14"D x 24"H Open Top & Front Burner - Tirrill 3/8" bore X 4" Gas - Ordinary illuminating Flame - 5" with 1-1/2" inner cone Gummed Kraft paper flame Ind. 20° wood wedge Clock or Watch</p>	<p>Specimen 18" in length Conditioning not mentioned</p>	
<p>UNDERWRITERS' LABORATORIES STD. 83 Tests for single-conductor, thermoplastic-insulated wires and cables of 2000 MCM and smaller and potentials greater than 600 volts.</p>	<p>Same as UL STD. 62</p>	<p>Same as UL STD. 62</p>	
<p>IPCEA-NEMA S-19-81 Paragraph 6.19.6 Test for rubber-insulated wires and cables used for transmission & distribution of electrical energy.</p>	<p>Same as UL STD. 62 except no mention is made of an open or closed front.</p>	<p>Specimen is approximately 22" in length.</p>	
<p>IPCEA S-61.402 (NEMA WC 5-1973) For testing of thermoplastic-insulated wires and cables which are used for transmission and distribution of electrical energy for normal conditions of installation and service, either indoors, aerial, underground or submarine.</p>	<p>Same as IPCEA-NEMA S-19-81</p>	<p>Same as IPCEA-NEMA S-19-81</p>	
<p>ASTM D2633-76 Method for testing thermoplastic insulations and jackets insulated wire & cable.</p>	<p>Chamber - 12"W x 14"D x 24"H Open top with closable front door Burner - Tirrill 3/8" x 4" Gas - Natural Flame - 5" with 1-1/2" inner cone Gummed Kraft Paper Flame Indicator Surgical Grade Cotton 20° wood wedge Clock or watch</p>	<p>Specimen 22" in length</p>	
<p>ASTM D2220-74 For testing insulation of poly(vinyl chloride) or the copolymer of vinyl chloride and vinyl acetate. Insulation recommended for use at conductor temp. not in excess of 75°C.</p>	<p>Same as ASTM D2633</p>	<p>Same as ASTM D2633</p>	
<p>UNDERWRITERS' LABORATORIES BULLETIN 758 To test flame-retardant properties of insulated wire.</p>	<p>Chamber - 12" W x 14" D x 24" H, Open top and front Burner - Tirrill - 3/8" bore x 4" Flame - 5" with 1 1/2" inner cone, 1500° F or higher 20° wood wedge Surgical cotton pad 1/2" gummed Kraft paper flame indicator Gas - Not mentioned</p>	<p>Specimen length not mentioned, probably less than 24" No conditioning mentioned</p>	

TABLE 4-3. CONTINUED

TEST NUMBER	PROCEDURE	REQUIREMENTS
	<p>UNDERWRITERS' LABORATORIES STD. 44 Flame is applied for 15 sec. and then removed for 15 sec. Then repeated for a total of 5 cycles. In no case shall the flame be reapplied until all flaming or glowing from a previous application has ceased of its own accord though the waiting period may exceed 15 sec. A 1/2" wide gummed Kraft paper tape flame indicator shall be placed 10" above flame application point which is 3" from bottom of vertical specimen. Cotton pad shall be placed 9-1/2" (max.) below flame impingement point.</p> <p>UNDERWRITERS' LABORATORIES STD. 62 Flame is applied in five 15 sec. cycles with a 15 sec. rest period between each application. Flame application point should be 3" (min.) from lower end of specimen. Paper flame indicator to be 10" above flame application point. Flame to be applied 20° from vertical.</p>	<p>If more than 25% of flame indicator is burned after any of 5 applications or if flaming or glowing particles or flaming drops fall on and ignite the cotton pad, specimen conveys flame. Specimens which flame or glow longer than 60 sec. after any flame application are not acceptable.</p> <p>If greater than 25% of flame indicator is destroyed after fifth flame application, specimen conveys flame. Duration of burning after the fifth flame application shall not exceed 60 seconds to be acceptable.</p>
	<p>UNDERWRITERS' LABORATORIES STD. 83 Same as UL STD. 62</p>	<p>Same as UL STD. 62</p>
	<p>IPCEA-NEMA 5-19-81 Paragraph 6.19.6 Same as UL STD. 62</p>	<p>Same as UL STD. 62</p>
	<p>IPCEA 5-61-402 (NEMA WC 5-1973) Same as UL STD. 62</p>	<p>Same as UL STD. 62</p>
	<p>ASTM D2633-76 Flame shall be applied to the specimen five times for 15 sec. duration with a 15 sec. rest period between applications. Paper flame indicator 10" above intersection of burner axis and axis of vertical specimen. Cotton pad is 9-1/2" (min.) below intersection of axes.</p>	<p>If more than 25% of flame indicator is burned after five applications of flame or if any particles or drops that fall during or within 30 sec. after the final flame application ignite the cotton, the wire is considered to have conveyed flame.</p>
	<p>ASTM D2220-74 Same as ASTM D2633</p>	<p>Maximum burning time after five 15 sec. flame applications is 1 minute.</p>
	<p>UNDERWRITERS' LABORATORIES BULLETIN 758 Same as UL STD. 44</p>	<p>Same as UL STD. 44</p>

TABLE 4-4. FLAMMABILITY TEST SUMMARY (OTHER THAN VERTICAL AND HORIZONTAL)

TEST NUMBER	PURPOSE	APPARATUS	SPECIMEN/CONDITIONING
<p>MIL-W-5086 (METHOD II) 30° FROM VERTICAL For polyvinyl chloride - insulated single conductor electric wires made with tin or silver-coated copper/copper alloy conductors. The insulation may be used alone or with other insulating or protective materials.</p>	<p>Chamber - 12" W x 12" D x 24" H Open top and front Burner - Bunsen, 3/8" bore x 4" Flame - 3" conical flame with 1" inner cone not less than 1750° F Tissue - Facial tissue conforming to UU-T-450</p>	<p>Specimen 24" in length No conditioning mentioned</p>	
<p>MIL-W-16878D (NAVY) 45° FROM VERTICAL Covers wires designed for the internal wiring of meters, panels and electrical/electronic equipment to have minimum size and weight consistent with service requirements. Rating of wire is 75° to 260°C and 250 to 3,000 volts.</p>	<p>Chamber - 12"W x 12"D x 24"H Open top and front Burner - Bunsen 4" x 3/8" bore Flame - 2" with 2/3" inner cone Gas - Not specified</p>	<p>Specimen 18" in length. No conditioning mentioned</p>	
<p>MIL-W-22759D 30° FROM VERTICAL Covers fluoropolymer-insulated single conductor electric wiring made with tin, silver, or nickel coated conductors of copper or copper alloys. Specification is approved for use of all Departments and agencies of the Dept. of Defense.</p>	<p>Chamber - 12"W x 12"D x 24"H Open Top & Front Burner - Bunsen or Tirrill 3/8" bore x 4", fitted with a wing top flame spreader having 2" x 1/16" opening. Flame - blue 2" high at Temp. of 955 ± 30° C</p>	<p>Specimen 24" in length. No pretest conditioning</p>	
<p>MIL-W-81044 30° FROM VERTICAL For crosslinked polyalkene insulated tin, silver or nickel coated/plated single conductor wire.</p>	<p>Chamber - 12" W x 12" D x 24" H Open top & front Burner - Bunsen, 3/8" bore x 4" Flame - 3" with 1" inner cone, not less than 1750° F Tissue - Sanitary tissue conforming to UU-T-450</p>	<p>Specimen 24" in length. No conditioning required.</p>	
<p>MIL-W-81381 30° FROM VERTICAL For Polyimide - insulated single conductor electric wires of silver or nickel-coated copper or copper alloy.</p>	<p>Chamber - 12" W x 12" D x 24" H Open top & front Burner - Bunsen, 3/8" bore x 4" Flame - 3" with 1" inner cone, not less than 1749° F Tissue - Facial tissue conforming to UU-T-450</p>	<p>Specimen 24" in length No conditioning required</p>	
<p>F.A.A., FAR 25.1359(d) and APPENDIX F 30° FROM THE VERTICAL Insulation on wiring installed in aircraft fuselage must be self-extinguishing when tested by this method.</p>	<p>Chamber - 12"W x 12"D x 24"H Open top and front Burner - Bunsen or Tirrill 3/8" bore X 4" Flame - 3" with 1" inner cone not less than 1749°F</p>	<p>Specimen 24" long and conditioned at 70 ± 5°F and 50 ± 5% relative humidity until moisture equilibrium is reached or 24 hours.</p>	
<p>IEEE STD. 383-74 To provide direction for establishing type tests which may be used for qualifying Class IE electric cables...For service in nuclear power generating stations.</p>	<p>In a naturally ventilated room or enclosure free from drafts. Tray - Ladder 3"d x 12"W x 8'H "L" shaped - connected to short length of horizontal tray (same size). A ribbon gas burner (10" wide) Gas - Propane Flame - approximately 1500°F and 15" high</p>	<p>No conditioning Power, control and instrumentation cables Cable Sizes - Multiple (see spec.)</p>	

TABLE 4-4. CONTINUED

TEST NUMBER	PROCEDURE	REQUIREMENTS
MIL-W-5086 (METHOD II) 30° FROM VERTICAL	Mark specimen 8" from its lower end and suspend it at 30° from vertical. Burner shall be held perpendicular to the specimen and 30° from its vertical plane. Apply the hottest portion of the flame to the lower side of the specimen at the test mark for 30 seconds. Suspend the tissue 9 1/2" below the test mark during the test.	Record distance of flame travel upward along the specimen from the test mark, time of burning after removal of the test flame and presence/absence of flame in tissue. Ignore charred holes or spots.
MIL-W-16878D (NAVY) 45° FROM VERTICAL	Specimen is held at 45° from vertical. Top of flame inner cone shall be applied to mark on specimen located 6" from lower end for 30 seconds.	The burning time and flame travel distance upward from test mark shall not exceed values specified in the detailed specification. Burning particles shall not fall from the specimen.
MIL-W-22759D 30° FROM VERTICAL	A 24" span of specimen suspended 30° from vertical. Burner flame is applied perpendicular to and under the specimen at test mark 8" from lower end. The long dimension of the flame spreader shall be parallel with the wire axis, with the center of the flame directed at the 8" test mark on the specimen. Flame application shall be 15 seconds for wire sizes 30 thru 18, 30 seconds for sizes 16 thru 12, 1 minute for sizes 10 thru 4, and 2 minutes for larger sizes. At the close of the application period, the flame shall be withdrawn.	Post flame dielectric test (described in specification) shall be performed without failure. The duration of the after flame in the specimen shall be noted.
MIL-W-81044 30° FROM VERTICAL	The specimen shall be suspended 30° from vertical with a mark 8" from the lower end. The burner shall be applied perpendicular to the specimen and 30° from its vertical plane at the 8" mark for 30 seconds. A sanitary tissue shall be suspended 9 1/2" below the flame-specimen intersection.	Record the flame travel distance along the wire from the mark, the burning time after flame removal and flame of tissue caused by falling particles.
MIL-W-81381 30° FROM VERTICAL	The specimen is to be clamped tautly at 30° from the vertical with a mark 8" from the lower end. The burner shall be held perpendicular to and 30° from the vertical plane of the specimen with the flame directed at the 8" mark for 30 seconds. The facial tissue shall be suspended 9 1/2" below the flame-specimen intersection.	Record the flame travel distance upward along the specimen from the test mark, burning time after flame removal and presence or absence of flame in facial tissue caused by falling particles.
F. A. A. , FAR 25.1359(d) and APPENDIX F 30° FROM THE VERTICAL	A 24" span of the specimen is suspended 30° from vertical. Burner flame is applied perpendicular to and under the specimen at test mark 8" from lower end. Remove flame after 30 seconds.	The average burn length may not exceed 3" and the average time after removal of source flame may not exceed 30 sec. Drippings from specimen may not continue to flame more than an average of 3 seconds after falling.
IEEE STD. 383-74	Cables to be arranged in a single layer filling at least center 6" portion of tray with half of the cable diameter between each cable. Burner situated horizontally 2 ft. above the bottom of the vertical tray.	The cable must not propagate fire, even if its outer cover is destroyed in the area of flame impingement.

flowing ceases on its own accord, even though the waiting period may exceed 15 seconds. A maximum burning time (flame and/or glowing) after the fifth flame application of 60 seconds is considered acceptable to the majority of the test specifications. If more than 25 percent of the paper tape flame indicator is burned, the specimen is considered, by most specifications, to convey flame.

Horizontal test requirements for the flame vary from a 5 inch height with a 1-1/2 inch inner blue cone to a 2 inch height with a 2/3 inch inner blue cone or a 2 inch by 1/16 inch wing top flame spreader. Some test specifications require that a facial tissue be placed under the test specimen to determine if flame is conveyed. Conditioning of the test specimen is not mentioned in any of the test specifications. The flame exposure time is a fixed 30 seconds on three of the specifications, but is variable (in steps dependent on wire size) on the other two. Pass/fail criteria are not specific, but the following observations are to be recorded:

- Whether specimen supporting flame extends beyond the flame impingement area.

- Behavior and duration of flaming after removal of test flame.

- Distance of flame travel in each direction

- Self-extinguishing time

- Presence/absence of flame in tissue

- Rate of flame travel

- Falling burning particles.

Other tests reviewed were primarily those which require that the test specimen be oriented at 30 degrees with respect to the vertical. The flame was required to be 3 inches high with a 1 inch inner blue cone, to 2 inches high with a 2/3 inch blue cone, or 2 inches high using a 2 inch by 1/16 inch wing top flame spreader. Facial tissues were required to be placed under the test specimen for measuring conveyance of flame in approximately 50 percent of the tests. Preconditioning was required in only one specification (FAA). The flame is oriented so that the burner stem is perpendicular to the specimen and exposed to it for 30 seconds, with the exception of one specification which required a variable time, depending upon the wire size being tested. With the exception of the FAA test, the pass/fail criteria are not specific, but the following observations are to be recorded:

Distance of flame travel upward
Time of burning after removal of test flame
Burning particles shall not fall from the specimen
Burning drippings shall not flame for more than 3 seconds (average)
after falling (no tissue required on this test)
Presence/absence of flame in tissue
One test requires that afterburn time not exceed 30 seconds
Perform and pass postflame dielectric test.

4.1.4 Selection of Flammability Test Methods

The majority of wire and cable in the transit system is installed horizontally. Therefore, it was postulated that the flammability test should be performed with the specimen held horizontally. It was conceded that a test in this position would be passed more easily than any other position. However, there is also a considerable amount of wire that is installed vertically in the transit car and in wayside installations. It would be an error to ignore this segment of wire installation, which is probably considered the "worst case condition" from a fire aspect. The resultant decision was to select both a horizontal and a vertical flame test. This decision helped in the method selection by eliminating tests that were not horizontal or vertical.

The much-discussed IEEE-383-74 test method was not used for the following reasons:

The large amounts of wire consumed in each test
Numerous comments in regard to the difficulty in getting repeatable results from laboratory to laboratory
Few laboratories have the necessary facilities for this test
Undetermined burner output for optimum results.

Most tests do not require preconditioning of the specimen prior to the test. It seemed that since a comparative test of insulating materials was being attempted, the specimens should all begin on equal ground and preconditioning should be required. The FAA flammability test requires that the specimen be conditioned at $70 \pm 5^{\circ}\text{F}$ and $50 \pm 5\%$ relative humidity for a period of not less than 24 hours. Most vertical tests require five 15 second flame applications with a 15 second period between each application. The repeated application of

flame appears to be directed toward determining the self-extinguishing characteristics of the insulating material. The five applications as stated above seemed excessive and unrealistic with respect to an actual fire condition, so the number was reduced to two, with varying durations of flame-exposure time according to the wire size, as discussed below.

The length of time that a specimen is exposed to flame should vary, depending on its size. As a flame is applied to a small wire, the insulation reaches the ignition temperature very rapidly, and if it is a flammable material, the heat generated by the burning insulation will sustain the flame. If a large wire with the same insulation is subjected to the same flame, a longer exposure time will be required for the insulation to reach the ignition temperature due to the increased capacity of the larger wire to absorb the heat. When the flame is removed, the thermal capacity of the large gauge wire will cause the flame to be sustained for a greater period of time than for the small wire. The flammability test in MIL-W-22759 demonstrates this point by specifying four different flame exposure times dependent on wire size. MIL-W-5086 (Method 1) and MIL-W-8777 (Procedure II) call for two different exposure times.

It was found by laboratory experiment that the standard Bunsen burner - 3/8 inch bore by 4 inch length - does not have the heat producing capability necessary for very large wires. A larger Fisher burner was selected for wires larger than 4 AWG.

The majority of the existing vertical tests position the burner at a 20 degree angle from the vertical, toward the specimen. There appeared to be no reason to deviate from this much-used angle. In tests using the Fisher burner, it became obvious that the Fisher burner should be tilted at a greater angle to engulf more of the larger wire within the flame and to simultaneously prevent the flame from being diverted directly up the side of the large specimen. The angle was increased to 40 degrees for the tests using the Fisher burner only. Most of the tests reviewed require that a gummed Kraft paper tape flame indicator be placed on the wire for measuring the conveyance of flame. A surgical cotton pad was required to be placed under the test specimen in about half of the tests reviewed for the conveyance of flame due to falling flaming droplets or burning particles. Both of these items were included in the adopted test methods.

The vertical flammability test selected is a modification of UL STD 44, the changes being as indicated below.

1. The flame is applied twice instead of five times.
2. The flame application time was varied depending on the wire size instead of 15 seconds regardless of the size.
3. The burner size was increased from a Bunsen or Tirrill to a Fisher burner for wire larger than AWG 4.
4. The test specimens were approximately 24 inches long, and wire was preconditioned at $70 \pm 5^{\circ}\text{F}$ and 50 ± 5 percent relative humidity for a minimum of 24 hours before test.

There are fewer existing horizontal test methods from which to make a selection. ASTM D 470 and IPCEA-NEMA S-19-81 (paragraph 6.13.2) are two very similar test methods. A third, MIL-W-5086 (Method 1) is similar except the burner is to be equipped with a 2 inch wing top flame spreader and is to have a facial tissue suspended under the specimen to detect conveyance of flame. The horizontal test includes variable flame exposure times, a cotton pad to measure flame conveyance, and a dielectric test to be performed on the specimen after the flame test has been performed.

The horizontal flammability test selected is a modification of ASTM D470. The modifications are as indicated:

1. The flame was applied once as on the referenced procedure but for varying amounts of time depending on the wire size.
2. The burner size was increased from the Bunsen or Tirrill to a Fisher burner for wire larger than AWG 4.
3. The test specimens were approximately 18 inches in length and wire preconditioned at $70 \pm 5^{\circ}\text{F}$ and 50 ± 5 percent relative humidity for a minimum of 24 hours before test.

4.1.5 Flammability Test Procedures

The repeatability of the results obtained from any test method is to some extent dependent on the procedures used to implement the test. Therefore it was considered necessary to develop detailed test procedures and test data sheets in addition to selecting the test method.

The test procedures and test data sheets for the horizontal and vertical tests and for the different wire size categories are included below.

4.1.5.1 Vertical Flammability Test For Wire Sizes 20 AWG - 4 AWG

APPARATUS

TEST CHAMBER	<ul style="list-style-type: none">- Sheet metal enclosure approximately 12 in. (30.5 cm) x 12 in. (30,5 cm) x 24 in. (61 cm) H.- Shall be open at the top and one vertical side.- Shall provide means to:<ul style="list-style-type: none">Hold specimen taut in a vertical position during the test.Hold burner in a position so that its axis is 20° from vertical and intersects the axis of the specimen.
BURNER	<ul style="list-style-type: none">- Bunsen/Tirrill type, 4 in. (10 cm) with 0.375 in. (1 cm) bore.
FLAME	<ul style="list-style-type: none">- Five in. (13 cm) with 1.75 in. (4.5 cm) inner blue cone and a temperature at $954 \pm 28^{\circ}\text{C}$ ($1750 \pm 50^{\circ}\text{F}$).
FLAME INDICATOR	<ul style="list-style-type: none">- Gummed Kraft paper tape.
GAS	<ul style="list-style-type: none">- Natural gas at a pressure of 6 in. (15.2 cm) of water.
COTTON PAD	<ul style="list-style-type: none">- Surgical grade cotton pad.
CLOCK	<ul style="list-style-type: none">- Digital clock indicating seconds or a clock with a hand that makes at least one revolution for each minute of elapsed time.

Figure 4-1 shows the vertical test setup.

PROCEDURE

A test specimen of sufficient length to fit in the test apparatus shall be marked at distances of 8 in. (20.3 cm) and 18 in. (45.7 cm) from one end. These marks indicate the intersection of the specimen and the burner axes and the lower edge

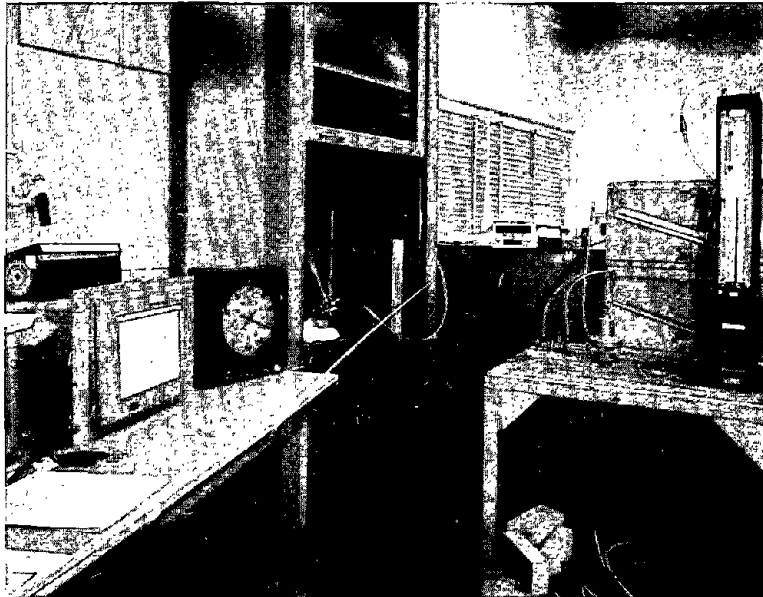

FIGURE 4-1. VERTICAL FLAMMABILITY TEST SETUP

of the flame indicator flag. The specimen shall then be conditioned at $21 \pm 3^{\circ}\text{C}$ ($70 \pm 5^{\circ}\text{F}$) and 50 ± 5 percent relative humidity for a minimum of 24 hours. The specimen shall remain in the conditioning environment until immediately before testing.

The test shall be conducted in a room generally free from drafts of air, although a ventilated hood may be used if air currents do not affect the flame. The specimen shall be oriented vertically and positioned tautly in the specimen holder of the test chamber. The means used should maintain tautness during the entire test. A dry surgical cotton pad shall be located a minimum of $9\frac{1}{2}$ in. (24.1 cm) below the flame-specimen intersection point.

The flame indicator flag shall consist of a 0.5 in. (12.7 mm) wide strip of gummed Kraft paper tape of 0.005 in. (0.127 mm) nominal thickness. The paper indicator shall be applied to the specimen so that the lower edge is 10 in. (25.4 cm) above the flame-specimen intersection point. Wrap the indicator once around the specimen, with the gummed side toward the conductor and the ends pasted evenly together and projecting 0.75 in. (19 mm) radially from the specimen on the opposite side to which the flame is to be applied. Moisten the gummed tape only to the extent that will afford proper adhesion.

The burner shall be adjusted to deliver the specified flame with the given gas pressure and at a temperature of $954 \pm 28^{\circ}\text{C}$ ($1750 \pm 50^{\circ}\text{F}$) as measured with a thermocouple pyrometer. The burner shall be held 20 degrees from the vertical so that the specimen passes through the tip of the blue inner cone, and the axis of the burner intersects the specimen at the "8 inch" mark on the specimen.

There shall be two flame applications. The duration of each flame application and the time between applications shall be as indicated in Table 4-5. At the end of the first flame application period, the flame shall be withdrawn and reapplied as indicated below or immediately after all flame and/or glowing embers have extinguished naturally, whichever occurs last. At the close of the second (final) application period, the flame shall again be withdrawn. All flames and/or glowing embers should be allowed to extinguish naturally.

TABLE 4-5 WIRE SIZE VERSUS VERTICAL FLAME APPLICATION TIME

Wire Size (AWG)	Flame Application Time (Sec.)	Time Between Flame Applications (Sec.)
20 & 18	10	15
16, 14 & 12	15	15
10 & 8	30	15
6	45	15
4	60	15

The following results and conditions shall be noted and recorded in the test data sheet shown in Figure 4-2.

- Ease of ignition upon application of flame (time to ignite).
- Ignition of the cotton pad due to falling burning particles and/or molten flaming droplets during the test.
- Duration of flame and/or glowing embers after each flame application.
- Length of damaged insulation beyond flame impingement, both above and below.
- Condition of the flame indicator flag.
- General color and quantity of smoke given off.
- Any other behavior of significance.

4.1.5.2 Vertical Flammability Test

For Wire Sizes Larger than 4 AWG

APPARATUS

TEST CHAMBER

- Sheet metal enclosure approximately 12 in. (30.5 cm) x 18 in. (45.7 cm) x 24 in. (61 cm) H.
- Shall be open at the top and one vertical side.
- Shall provide means to:
 - Hold specimen taut in a vertical position during the test.
 - Hold burner in a position so that its axis is 40° from vertical and intersects the axis of the specimen.

VERTICAL FLAMMABILITY TEST DATA SHEET						Sheet No. _____	
Material Description						Wire Size _____ AWG _____ MCM	
Manufacturer/Supplier						Burner Type <input type="checkbox"/> Bunsen <input type="checkbox"/> Fisher	
Gas Pressure <u>6.0</u> In. H ₂ O			Differential Pressure _____ In. H ₂ O			Flame Temp. _____ °F	
Test Date / /				Tested By			
Specimen No.	1	2	3	4	5	6	Average
Duration of first flame application, seconds.							
Time to ignition, seconds.							
Flaming after flame removal, seconds.							
Glowing embers after flame removal, seconds.							
Duration of second flame application, seconds.							
Total time between flame applications, seconds.							
Flaming after flame removal, seconds.							
Glowing embers after flame removal, seconds.							
Did:							
Specimen drip?	Yes						
	No						
Burning particles fall?	Yes						
	No						
Specimen convey flame to cotton pad?	Yes						
	No						
Specimen convey flame to flame indicator?	Yes						
	No						
Burn area:							
Distance from mark, Inches.	Above						
	Below						
	Total						
Smoke:							
<input type="checkbox"/> Heavy	<input type="checkbox"/> Moderate/Heavy	<input type="checkbox"/> Moderate	<input type="checkbox"/> Light/Moderate	<input type="checkbox"/> Light	<input type="checkbox"/> None observed		
<input type="checkbox"/> Black	<input type="checkbox"/> Black/Gray	<input type="checkbox"/> Gray	<input type="checkbox"/> Gray/White	<input type="checkbox"/> White			
Comments:							

FIGURE 4-2. VERTICAL FLAMMABILITY TEST DATA SHEET

BURNER	- Fisher burner with 1.50 in. (4.0 cm) diameter grid.
FLAME	- Adjust so that small cones between grid openings are of approximately 0.125 in. (3.2 mm) high and the non-luminous flame is 8 to 9 in. (20 to 23 cm) high, with a temperature of $982 \pm 28^{\circ}\text{C}$ ($1800 \pm 50^{\circ}\text{F}$).
FLAME INDICATOR	- Gummed Kraft paper tape.
GAS	- Natural gas at a pressure of 6 in. (15.2 cm) of water.
COTTON PAD	- Surgical grade cotton pad.
CLOCK	- Digital clock indicating seconds or a clock with a hand that makes at least one revolution for each minute of elapsed time.

Figure 4-3 shows the horizontal and vertical test setup for large gauge wire.

PROCEDURE

A 30 in. (76.2 cm) test specimen is marked at a distance of 8 in. (20.3 cm) from the lower end to indicate the intersection of the specimen and burner axis. The specimen shall then be conditioned to $21 \pm 3^{\circ}\text{C}$ ($70 \pm 5^{\circ}\text{F}$) and 50 ± 5 percent relative humidity for a minimum of 24 hours. The specimen shall remain in the conditioning environment until immediately before testing.

The test shall be conducted in a room generally free from drafts of air although a ventilated hood may be used if air currents do not affect the flame. The specimen shall be oriented vertically and positioned tautly in the specimen holder of the test chamber. The means used should maintain tautness during the entire test. A dry surgical cotton pad shall be located a minimum of 9-1/2 in. (24.1 cm) below the flame-specimen intersection point.

The flame indicator flag shall consist of a 0.5 in. (12.7 mm) wide strip of gummed Kraft paper tape of 0.005 in. (0.127 mm) nominal thickness. The paper indicator shall be applied to the specimen so that the lower edge is 10 inches (25.4 cm) above the flame-specimen intersection point. Wrap the indicator once

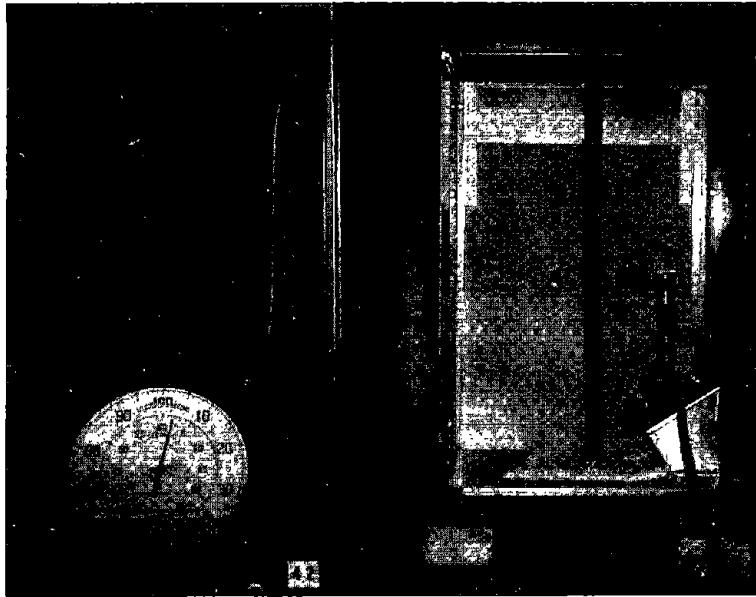

4-3a. Vertical



4-3b. Horizontal

FIGURE 4-3. LARGE GAUGE WIRE FLAMMABILITY TEST SETUP

around the test specimen with the gummed side toward the specimen and the ends pasted evenly together and projecting 0.75 in. (19 mm) radially from the specimen on the opposite side to which the flame is to be applied. Moisten the gummed tape only to the extent that will afford proper adhesion.

The burner shall be adjusted to produce a flame as described above and at a temperature of $982 \pm 28^{\circ}\text{C}$ ($1800 \pm 50^{\circ}\text{F}$) when measured with a thermocouple pyrometer. Gas pressure shall be held constant as indicated. The burner shall be held 40 degrees from the vertical so that the specimen passes through the flame and the edge of the specimen is within 1/2 inch of the edge of the burner. The axis of the burner shall intersect the axis of the test specimen at the "8 inch" mark.

There shall be two flame applications. The duration of each flame application and the time between applications shall be as indicated in Table 4-6. At the end of the first flame application period, the flame shall be withdrawn and reapplied as indicated in the table or immediately after all flame and/or glowing embers have extinguished naturally, whichever occurs last. At the close of the second (final) application period, the flame shall again be withdrawn. All flames and/or glowing embers should be allowed to extinguish naturally.

TABLE 4-6 WIRE SIZE VERSUS VERTICAL FLAME APPLICATION TIME

Wire Size	Flame Application Time (Sec.)	Time Between Flame Application (Sec.)
2/0 AWG	90 (1.5 min.)	15
500 MCM	240 (4 min.)	15
1000 MCM	360 (6 min.)	15
2000 MCM	600 (10 min.)	15

The following results and conditions shall be noted and recorded in the test data sheet shown in Figure 4-2.

- Ease of ignition upon application of flame (time to ignite).
- Ignition of the cotton pad due to falling burning particles and/or molten flaming droplets during the test.

- Duration of flame and/or glowing embers after each flame application.
- Length of damaged insulation beyond flame impingement, both above and below.
- General color and quantity of smoke given off.
- Condition of the flame indicator.
- Any other behavior of significance.

4.1.5.3 HORIZONTAL FLAMMABILITY TEST

APPARATUS

- | | |
|--------------|--|
| TEST CHAMBER | <ul style="list-style-type: none"> - Sheet metal enclosure approximately 12 in. (30.5 cm) x 12 in. (30.5 cm) x 24 in. (61 cm) H. - Shall be open at the top and one vertical side. - Shall provide means to support the test specimen in a horizontal position. - Shall provide means to support the burner perpendicular to the specimen and 20° from the vertical. |
| BURNER | <ul style="list-style-type: none"> - Bunsen/Tirrill type burner for small wire (20 through 4 AWG) 4 in. (10 cm) with 0.375 (1 cm) bore. - Fisher burner for large wire (larger than 4 AWG) with 1.50 in. (40 cm) diameter grid. |
| FLAME | <ul style="list-style-type: none"> - Bunsen/Tirrill - 5 in. (13 cm) with 1.75 in. (45 cm) inner blue cone and a temperature of $954 \pm 28^{\circ}\text{C}$ ($1750 \pm 5^{\circ}\text{F}$). - Fisher - adjust so that small cones between grid openings are approximately 0.125 in. (3.2 cm) high and the non-luminous flame is 8 to 9 in. (20 to 23 cm) high and the temperature is $982 \pm 28^{\circ}\text{C}$ ($1800 \pm 50^{\circ}\text{F}$). |
| COTTON PAD | <ul style="list-style-type: none"> - Surgical grade cotton pad. |
| GAS | <ul style="list-style-type: none"> - Natural gas at a pressure of 6 in. (15.2 cm) of water. |
| CLOCK | <ul style="list-style-type: none"> - Digital indicating seconds or clock with hand that makes at least one revolution for each minute of elapsed time. |

Figure 4-4 shows the horizontal test setup.

PROCEDURE

A test specimen of sufficient length to fit in the test apparatus shall be conditioned to $21 \pm 3^{\circ}\text{C}$ ($70 \pm 5^{\circ}\text{C}$) and 50 ± 5 percent relative humidity for a minimum of 24 hours. The specimen shall remain in the conditioning environment until immediately before testing.

The test shall be conducted in a room generally free from drafts of air, although a ventilated hood may be used if air currents do not affect the flame. Position the test specimen in a horizontal position on supports 8 in. (20.3 cm) apart. The cotton pad shall be positioned a minimum of 9.5 in. (24.1 cm) directly below the specimen.

The burner shall be adjusted for the required flame, positioned perpendicular to the specimen, and 20° from the vertical so that the specimen is in the tip of the inner blue cone on the Bunsen/Tirrill burner or approximately 2 inches (5 cm) from the top of the Fisher burner. In this section, direct the flame against the specimen for a period of time as indicated in Table 4-7 and then remove it. During the test, as well as after the application of the flame, observe whether or not the area of the specimen supporting flame extends outside the area exposed to the flame. Also note the behavior and duration of the flaming of the specimen after the application of the test flame.

TABLE 4-7 WIRE SIZE VERSUS HORIZONTAL FLAME EXPOSURE TIME

Wire Size (AWG)	Flame Exposure Time (Sec.)
20	10
16	15
8	45
4	90 (1.5 min)
2/0	120 (2.0 min)
500 MCM	240 (4.0 min)
1000 MCM	360 (6.0 min)
2000 MCM	600 (10 min)



FIGURE 4-4. HORIZONTAL FLAMMABILITY TEST SETUP

4.1.5.3.1 POSTFLAME DIELECTRIC TEST (HORIZONTAL TEST SPECIMENS ONLY)

To be conducted at least 1/2 hour after completion of the burning. The specimen from the flame test shall be clamped firmly in a horizontal position, leaving the burned portion of the wire accessible to a contact plate jig similar to that shown in Figure 4-5. The bottom contact plate shall be placed underneath the wire and shall make contact with the center 0.5 in. (1.3 cm) area of the burned section of the wire on the side of the insulation which has been nearest the flame. The upper contact plate shall be placed on top of the specimen, directly over the bottom plate, and a 1/4 pound (113.4 gm) weight shall be placed on the upper plate, directly over the specimen, to ensure contact with the burned area. A voltage shall then be applied between the conductor of the specimen and the contact plates of the jig. The voltage shall be increased at a uniform rate of 500 V rms/second from zero to failure of the damaged insulation on the test specimen.

All of the test data shall be recorded in the test data sheet shown in Figure 4-6.

4.1.6 Pass/Fail Criteria

Having selected a test method, devised a detailed test procedure, and designed a test data sheet, the next important task is to identify and quantify the flammability test pass/fail criteria. The following pass/fail criteria were selected:

4.1.6.1 VERTICAL FLAMMABILITY TEST

1. The burned (damaged) area should not exceed
 - a. 4 AWG (Bunsen Burner) - 6.0 inches up and 1.3 inches down. (Measured from the intersection point of the specimen and the centerline of the burner).
 - b. 4 AWG (Fisher Burner) - 10.0 inches up and 2.2 inches down.

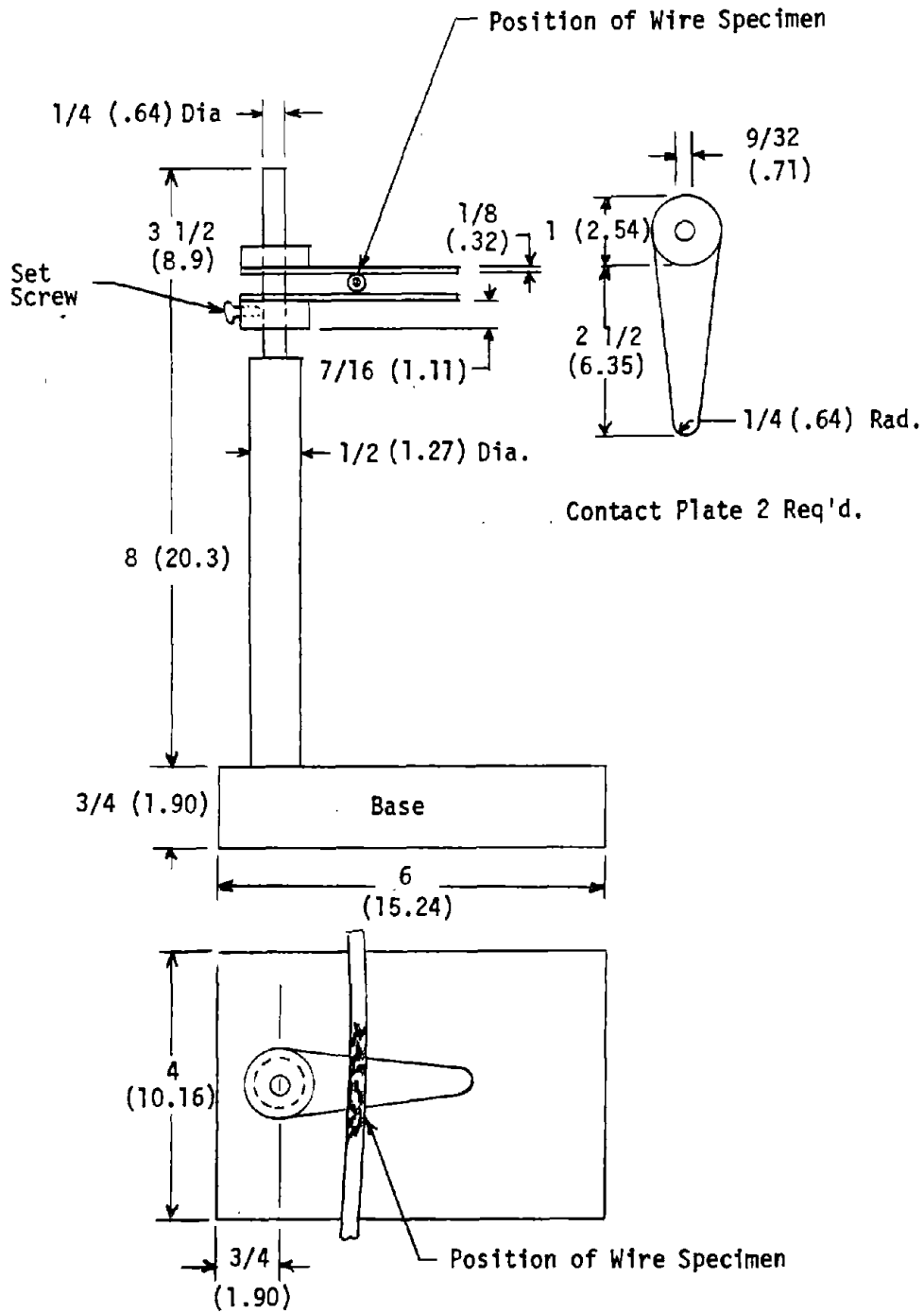

•Dimensions in inches (centimeters)

- Material:
- Base: Nonconductor
- Contact plates: Polished brass
- Upright supports: Brass

FIGURE 4-5. CONTACT PLATE JIG FOR POSTFLAME DIELECTRIC TEST

HORIZONTAL FLAMMABILITY TEST DATA SHEET

Sheet No. _____

Material Description _____ Wire Size _____ AWG _____ MCM

Manufacturer/Supplier _____ Burner Type Bunsen Fisher

Gas Pressure 6.0 In. H₂O Differential Pressure _____ In. H₂O Flame Temp. _____ °F

Test Date / / _____ Tested By _____

Specimen No.	1	2	3	4	5	6	Average
Duration of flame application, seconds.							
Time to ignition, seconds.							
Flaming after flame removal, seconds.							
Glowing embers after flame removal, seconds.							
Dielectric breakdown, Volts							

Did:

Specimen drip?	Yes						
	No						
Burning particles fall?	Yes						
	No						
Specimen convey flame to cotton pad?	Yes						
	No						

Burn area:

Distance, Total Inches							
------------------------	--	--	--	--	--	--	--

Smoke:

- Heavy
 Moderate/Heavy
 Moderate
 Light/Moderate
 Light
 None observed
- Black
 Black/Gray
 Gray
 Gray/White
 White

Comments: _____

FIGURE 4-6. HORIZONTAL FLAMMABILITY TEST DATA SHEET

2. The maximum time that a specimen may flame and/or glow after any withdrawal of the gas flame shall be:
 - a. 50 seconds for ≤ 4 AWG
 - b. 100 seconds for > 4 AWG
3. Not more than 25 percent of the flame detector shall burn to show that the insulation does not convey flame.
4. Falling molten, flaming and/or burning particles shall not cause the cotton pad to flame, to show that the insulation does not convey flame.
5. Ignition time of less than one second is not acceptable.

4.1.6.2 HORIZONTAL FLAMMABILITY TEST

1. The total burned (damaged) area should not exceed
 - a. 2.0 inches for ≤ 4 AWG
 - b. 4.0 inches for > 4 AWG
2. The maximum time that a specimen may flame and/or glow after the withdrawal of the gas flame shall be:
 - a. 50 seconds for ≤ 4 AWG
 - b. 100 seconds for > 4 AWG
3. Falling molten, flaming and/or burning particles shall not cause the cotton pad to flame, to show that the insulation does not convey flame.
4. Ignition time of less than one second is not acceptable.
5. Dielectric breakdown at less than 100 volts is not acceptable.

NOTE: Some teflons and silicone rubbers were found to crack after cooling from the flame exposures. This behavior was not thought to be detrimental to the performance of material because our concern is the performance during a fire situation and not after it. This cracking usually shows up as a failure on the dielectric test which follows the horizontal flammability test.

4.2 Smoke Test Methods

Following any large-loss fire, where the smoke produced by surface materials has appeared to be a factor, many officials have been tempted to apply regulations which would limit the amount of smoke produced by the surface burning of materials. However, very few people have made enough observations of smoke density under fire conditions to give any relative meaning to the values of smoke produced. Smoke contributes then to two problems (a) obscuration of escape paths and exits and (b) suffocation due to insufficient oxygen and/or incapacitation due to the toxic effect of the fumes. Obviously, limiting the smoke produced by an insulation in a flammability situation would tend to minimize the effects discussed above.

A number of attempts have been made to quantitatively define the smoke produced from a burning material. These attempts have resulted in several methods of smoke measurement, some of which have been adapted to existing flammability test methods and apparatus while others have been developed with the specific intent of evaluating smoke production. Lacking, however, are test methods designed specifically for the measurement and analysis of smoke produced by electrical wire and cable insulation resulting from externally applied heat and flame, internally generated heat due to circuit resistance, or any combination of these factors.

4.2.1 Approach

The technical approach used to arrive at a suitable smoke test method was similar to that described in paragraph 4.1.1 to develop the flammability test. However, since it was already known that there were no test methods devised specifically

for all sizes of wire and cable, it was recognized that considerable laboratory testing would be necessary to evolve a suitable test.

4.2.2 Test Selection Criteria

Prior to the review of existing methods of testing for smoke emission, it was necessary to identify the criteria applicable to the selection of the test. Additionally, weighting factors were assigned to these criteria according to their importance.

The following criteria were established for the smoke test. The selected method should:

- Measure the density (amount) of smoke emitted with time by the specimen material being tested.
- Be an existing method or a modification of an existing method.
- Be a test with which the industry has some familiarity and confidence so that the results of the study will be more acceptable.
- Provide repeatable results from test to test and from laboratory to laboratory.
- Be capable of testing a wide range of wire and cable sizes, e.g., 20 AWG - 2000 MCM.
- Be low in cost. It should not require expensive test equipment/facilities, should not require costly training of personnel, and should not use large amounts of wire.
- Be simple to conduct.
- Simulate the installation.
- Simulate the fire.

Not all of these criteria are of equal importance, and thus weighting factors were assigned as shown in Table 4-8. The method used to derive these weighting factors is discussed in Appendix A.

TABLE 4-8 TEST SELECTION CRITERIA AND WEIGHTING FACTORS

Criteria	Weighting Factor
Smoke emission characteristics and density	.250
Repeatable	.214
All sizes and constructions	.179
Existing Method	.143
Low cost	.107
Simplicity	.072
Simulate fire	.036
Simulate installation	0

4.2.3 Analysis of Existing Test Methods

There are two general categories of existing smoke test methods which were subjected to analysis. The first category can be described as a go, no-go type of test found in most older military and many commercial specifications for wire and cable. In these tests the specimen is suspended against a dark background to help the unaided eye detect smoke. The specimen is then heated to a specific temperature by subjecting it to current. While at the specified temperature, the specimen is visually examined for smoke emission. This category of test may provide some degree of confidence that an insulating material is not completely worthless, but it is meaningless as an evaluation of the smoke emission characteristics of wire and cable.

The second category of tests attempts to measure the smoke emission parameters beyond the "yes or no" (at a specific test point) of the first category. Examples of tests in this category are those which calculate smoke as a measure of light obscuration, sample weight loss, smoke particle and ash weight, density of smoke spot on filter element, maximum smoke density, total smoke production, and maximum obscuration rate.

The nine different smoke test methods which were considered worthy of further consideration are summarized in Table 4-9. The salient features of these methods are discussed below and a more rigorous discussion is included in Appendix B.

TABLE 4-9. SMOKE TEST METHOD SUMMARY

TEST METHOD	SPECIMEN SIZE/CONDITION	METHOD OF HEATING	TYPE OF COMBUSTION	AIR SUPPLY	CHAMBER	TIME	RESULTS
Arpahoe	1 1/2" x 1/2" x 1/8" weigh sample; accuracy + 0.2 mg. After test, weigh burned sample. Dechar 45 minutes and weigh again.	Propane Micro-burner	Free burning	Air velocity 4.5 CFH	30" x 5" x 5"	30 seconds	Total amount burned = (initial sample weight) - (Decharred sample weight) Smoke weight = (filter + smoke weight) - (initial filter weight) Char weight = (burned sample weight) - (Decharred sample weight) % smoke = (smoke weight) ÷ (total amount burned)
ASTM D 2843 (Rohm & Haas XP2)	1" x 1" x 1/4" (Rohm & Haas) 2" x 2" x 2" (Wayne State, U.) 23 ± 2% RH 50 ± 5% RH for not less than 40 hours.	Propane Gas burner	Free burning	No Ventilation	30" x 12" x 12"	4 minutes	Light absorption in % $(I_0 - I)/I_0 \times 100$
NBS Smokechamber	2 9/16" square Surface Exposed	Radiating 2.5 W/cm ²	Flaming or non-flaming controlled by a pilot flame	No Ventilation	36" x 36" x 24"	Usually ≥ 30 min.	Specific Optical Density $D_s = V/AL \text{ Log}_{10} (I_0/I)$
Lawrence Radiation Laboratory	2 9/16" square Surface Exposed	Radiating 2.5 W/cm ²	Flaming or non-flaming controlled by a pilot flame	Ventilation - 0 to 20 air changes per hour	36" x 36" x 24"	Usually ≥ 30 min.	Specific Optical Density $D_s = V/AL \text{ Log}_{10} (I_0/I)$
Commonwealth Experimental Building Station	50 mm Diameter Surface Exposed	Radiating 3.5 W/cm ²	Flaming or non-flaming controlled by O ₂ Electric sparks for ignition.	10 to 21% O ₂ in atmosphere	5.7 cubic meters	Time to reach maximum concentration	Specific Optical Density
ASTM E 84 (Steiner Tunnel)	20 1/4" x 24" (36 ft. 2 exposed) conditioned at 35 to 40% RH to a constant weight	Own heat of Combustion	Free burning	Air velocity 240 ± 5 Ft./Min.	77 3/4" x 12" x 25"	10 min. (less if test specimen is completely consumed prior to 10 min.)	Area under time-light absorption curve
ASTM E 162	6" x 18" Predry 24 hr. at 140°F Condition 73 ± 5°F at 50 ± 5% RH	Radiation equal to black body of same dimension at 1238 ± 7°F	Free burning	40 Ft./min.	18" x 9" x 6"	Earliest of progression of flame front the full length of specimen or 15 minutes.	Weight of smoke deposit on filter and optical density of deposited smoke film (density range 0 to 4.5)
Building Research Institute, Japan	1 gram, kept in desiccator about 20 days.	Electric Furnace Temp. varied 300 to 550°C	Flaming or non-flaming controlled by temperature	Free Convection	0.5 Cu Meter	unknown	Smoke generation coefficient $k \text{ V/ML Log}_e (I_0/I)$
ASTM D 757 (CASS)	0.200 to 0.400 Gram 23 ± 2°C at 50 ± 5% RH	Globar (incandescence)	Free burning	Free convection	Laboratory Hood	0 to 20 sec. ignition 10 to 30 sec. burning	% smoke by weight

The Arapahoe test has advantages in that it was designed as a smoke test, the test time is short (approximately 1 min.), has good repeatability, and is relatively inexpensive (test setup and materials). The disadvantages are that it uses a very small sample size, smoke emission is calculated as a function of weight loss, it does not measure obscuration of light, it requires 45 minute decharring of samples, and it may not ignite some samples in a short time. The amount of smoke which may occur before passage of air through the chamber is another limitation.

The ASTM D 757 test has the advantage that the apparatus used is the same as that used for flammability testing, resulting in low cost. The disadvantage is that the smoke emission is calculated by weight loss only.

The Steiner Tunnel Test (ASTM E 84) measures smoke emission, i.e., the degree by which it obscures light, and can be used to simulate installations. The disadvantages are that it requires a large area due to the size of the tunnel, it incurs high test material cost, and the smoke density reference is red oak. It also contains a flame spread rate test for construction materials.

ASTM E 162 is really a test for surface flammability and does not measure smoke emission but depends on weight measurement.

The XP2 (Rohm and Haas) was developed to measure the rate of smoke generation and visibility obscuration effects, and the cost of the tests are low. Disadvantages are that the size of the test sample is limited, the light beam is horizontal and subject to the effects of stratification, and manual observations are involved in deriving the test data.

The National Bureau of Standards (NBS) Test measures the rate of smoke generation and visibility obscuration, a vertical light beam is used, it is capable of additional tests such as gas sampling, and it has already been established as an industry standard for fabric testing and has been proposed as a standard for wire testing. It has the disadvantage of small sample size and its repeatability has been questioned.

None of the above test methods were developed specifically with wire and cable testing in mind. But a method had been developed to test wire which utilizes the NBS chamber.

4.2.4 Selection of Smoke Emission Test Method

None of the test facilities and methods reviewed were specifically designed to test electrical wire and cable. Therefore, the approach taken was to select a test facility which most nearly met all of the selection criteria and which could best accommodate a method of testing wire and cable. Table 4-10 shows the result of applying the procedure described in Appendix A to the selection of the test facility. As can be seen, the most promising facility was the NBS Smoke Chamber, which is shown in Figure 4-7.

The existing NBS test for wire uses a 3" x 3" comb shown in Figure 4-8 around which 10 ft of 20 AWG is wrapped as illustrated by Figure 4-9. The sample wrapped on the comb is exposed to flaming and/or radiant heat, and the resultant smoke emission is detected by a photocell which measures light attenuation due to the smoke. The amount of smoke emitted by the sample is usually quantified in terms of the Specific Optical Density (D_S). The relationship between D_S and the pertinent variable parameters is as follows:

$$D_S = \frac{V}{LA} \log \frac{100}{T}$$

where

V	=	Chamber Volume
L	=	Path length over which the light passes
A	=	Surface area of sample being burned
T	=	Present transmission of light beam

The major problem with the NBS chamber approach is that the 3" x 3" comb was designed to accommodate 20 AWG wire. Since the usage of 20 AWG in the rapid transit area is presently non-existent, it was felt necessary to develop a correlated method for testing larger gauge samples. At this point, a series of laboratory experiments were conducted to determine which of any of four mathematically inspired approaches to determining equivalency of lengths of wire to be used based on wire gauge. These experiments were conducted using PVC jacketed vinyl insulated wire. This wire was used because it can be classified as giving off a considerable quantity of smoke and as a result would be a good indicator of differences which occur from method to method and from gauge to gauge.

TABLE 4-10 RATING OF SMOKE TEST METHODS VERSUS SELECTION CRITERIA

SELECTION CRITERIA	Arapahoe	ASTM D 757 (Gass)	ASTM D 2843 Romm & Hass	ASTM E 162	ASTM E 84 Steiner Tunnel	Bldg. Research Institute	Commonwealth Exp. Building	Lawrence Rad. Laboratory	NBS
Smoke Characteristic	.014	0	.035	.014	.014	.028	.042	.049	.056
Repeatability	.036	.048	.006	.018	.006	.024	.012	.030	.036
All Sizes & Constructions	.005	.010	.020	.025	.040	.005	.015	.030	.035
Existing Methods for Wire	.008	.012	.016	.020	.032	0	.004	.024	.028
Low Cost	.021	.024	.015	.018	0	.006	.003	.009	.012
Simplicity	.006	.012	.010	.006	.002	.004	.002	.013	.016
Simulate Fire	.003	.002	.004	.005	.008	0	.001	.005	.006
TOTAL POINTS	.093	.108	.106	.106	.102	.069	.079	.160	.187

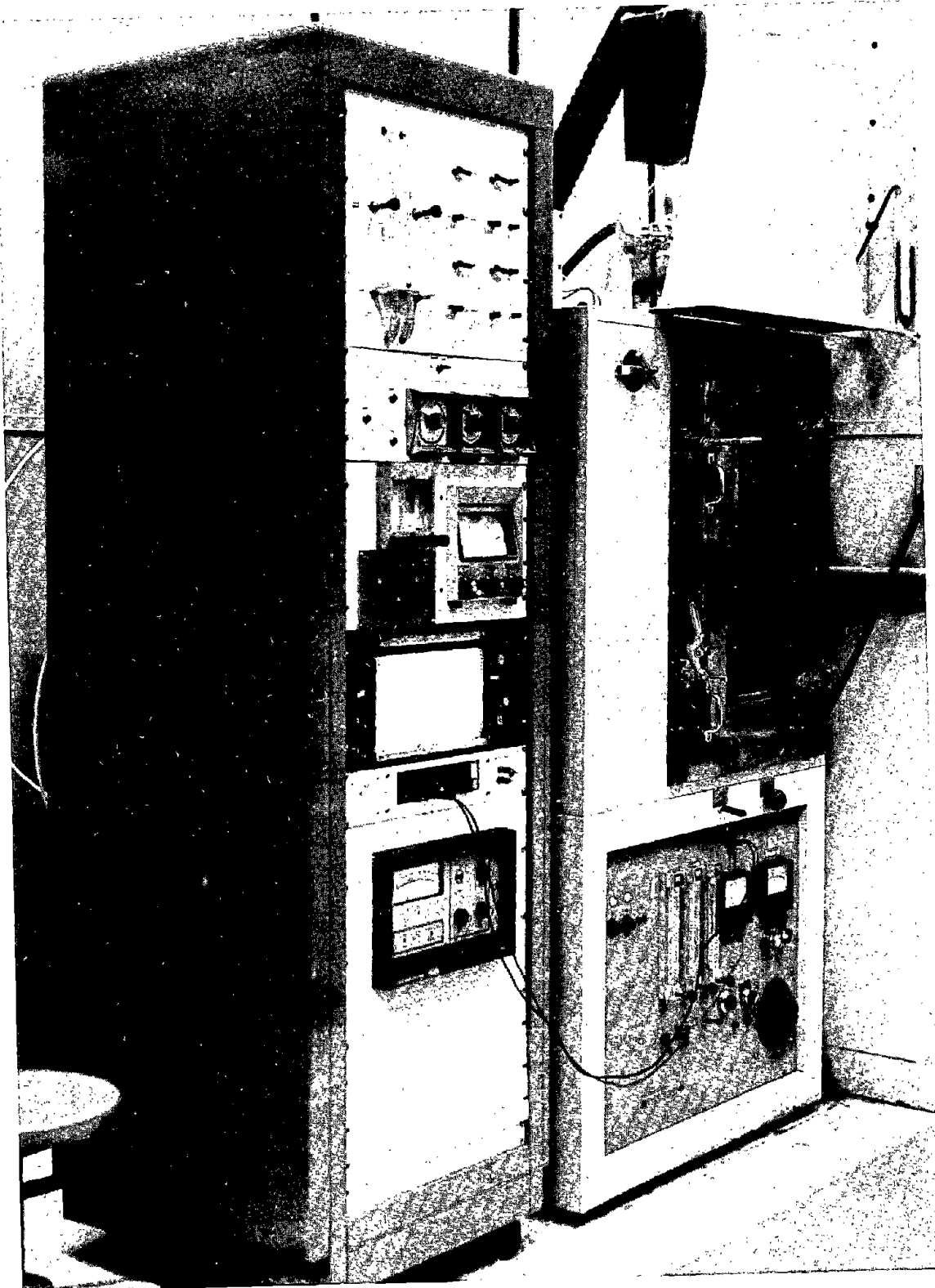

FIGURE 4-7. NBS AMINCO SMOKE CHAMBER

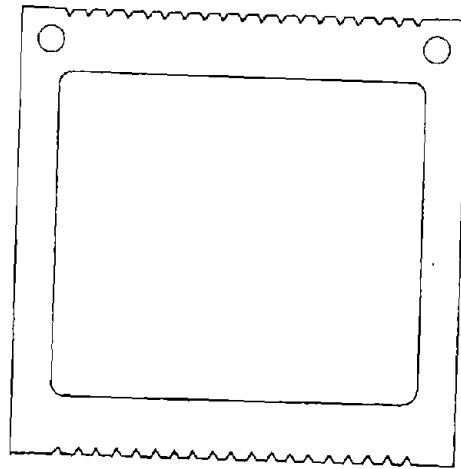
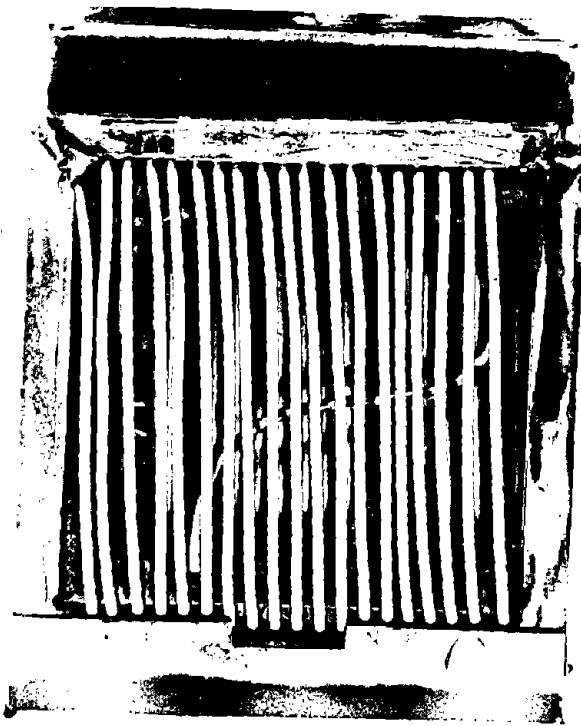
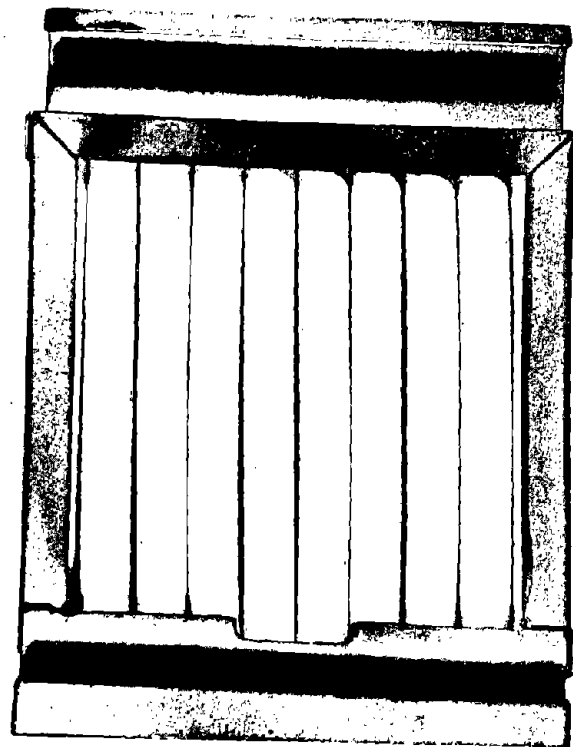

FIGURE 4-8. WIRE COMB



Small Wire Sizes



Large Wire Sizes

FIGURE 4-9. MOUNTING THE TEST SPECIMEN

The first approach was to use the same sample length for each wire size. This approach was quickly abandoned because as the wire size increased so did the problems of bending the wire to get it around the comb and ultimately bending the wire to get it into the chamber. The results of testing 10 ft AWG 20, 16, and 12 are shown in Figure 4-10. The limited number of wire sizes is due to the fact that the comb could only accept 20 ft of size 20, 16, and 12 AWG. When the lengths are equal, the large wire size has a greater amount of insulation (surface area and wall thickness) than the smaller sizes. As was expected, Figure 4-10 shows that the larger wires produced more smoke over a greater period of time.

The second approach was to use 10 ft of AWG 20 as the baseline and calculate the length of other sizes to be tested as a function of equivalent surface area, e.g., for the particular wire type being tested, 7.9 ft of 16 AWG and 5.4 ft of 12 AWG contributed the same surface area. The results of testing these specimens are shown in Figure 4-11. Examination of Figure 4-11 shows that this approach can be used to test a wide range of wire sizes. Since surface area is one of the variables in the D_S calculation, it was postulated that a constant value of D_S would be obtained when testing samples whose size is based on a constant surface area. However, the results of the test indicate that while, in general, the peak value of smoke emission is achieved at the same time, a wide spread of the maximum value of D_S (usually designated as D_m) is obtained. D_m may occur at any time from shortly after the test begins until the end of the test, depending upon the material.

The third approach was to compare specimens of wire, the length of which was a result of keeping the mass of insulation as a constant, again using a mass of insulation contained in 10 ft of 20 AWG as the baseline. The results of this test, shown in Figure 4-12, were most encouraging in that a large number of wire sizes can be tested, the curves for different wire sizes all have the same general form, and a somewhat narrow range of D_m was obtained for all wire sizes.

Another approach which was investigated was to use a constant conductor mass using 10 ft of 20 AWG wire as the baseline to determine the length of the test specimen. This approach was based on the premise that equal conductor mass would provide equal "heat sink" capability and would lead to D_m at the same time. As can be seen from Figure 4-13, the wide variation in values obtained

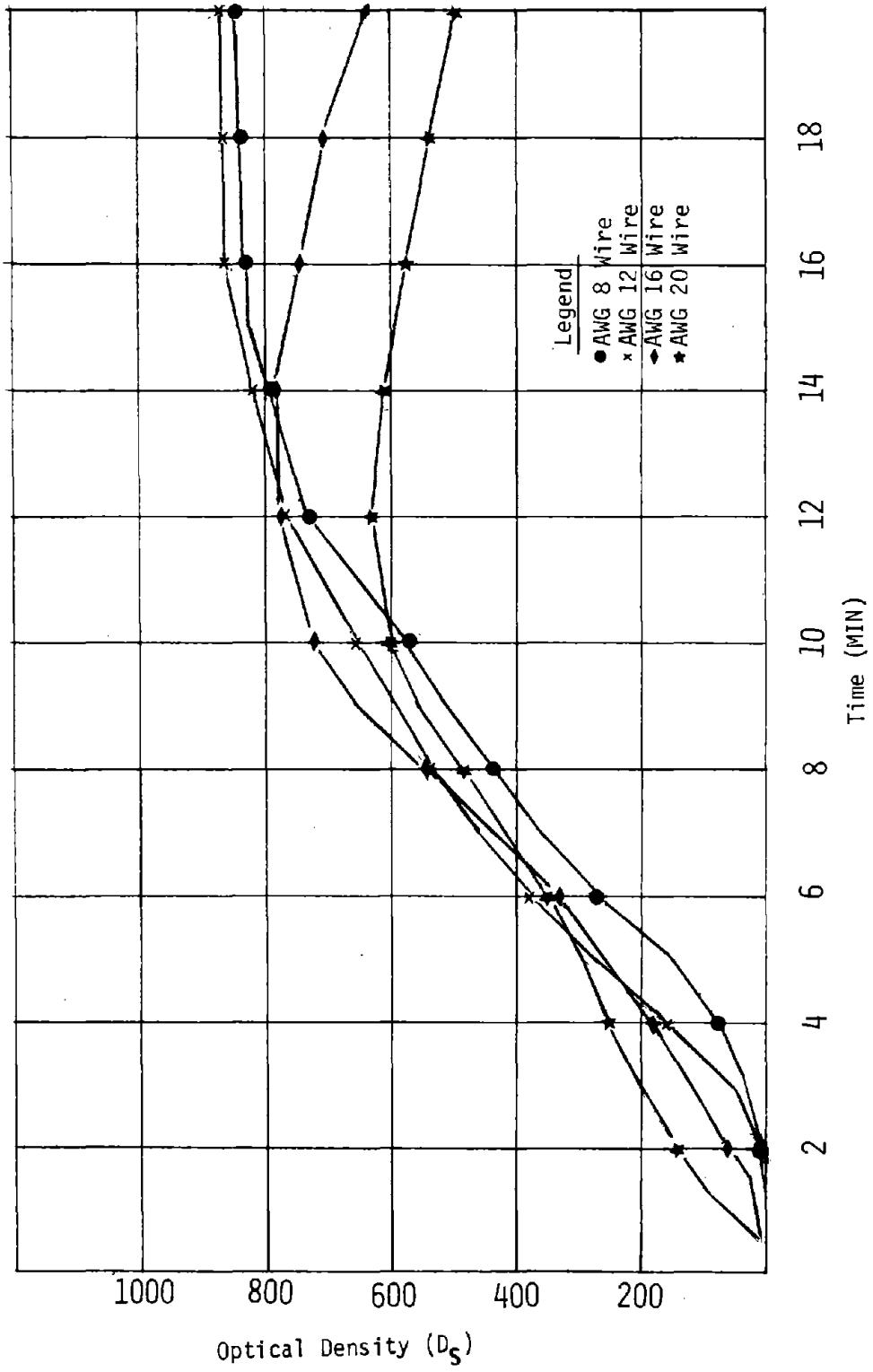

FIGURE 4-10. SMOKE DENSITY VERSUS LENGTH

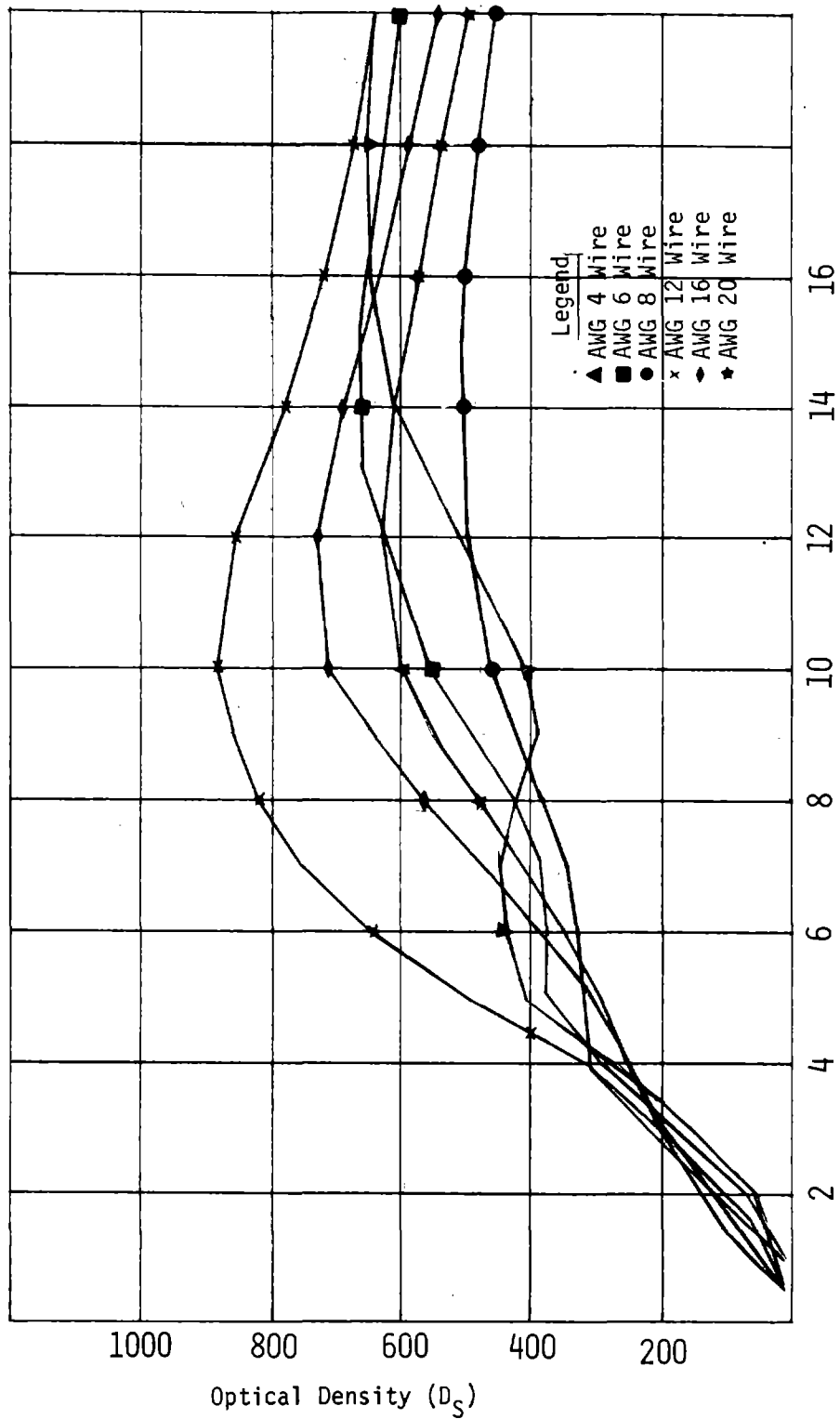

FIGURE 4-11. SMOKE DENSITY VERSUS SURFACE AREA

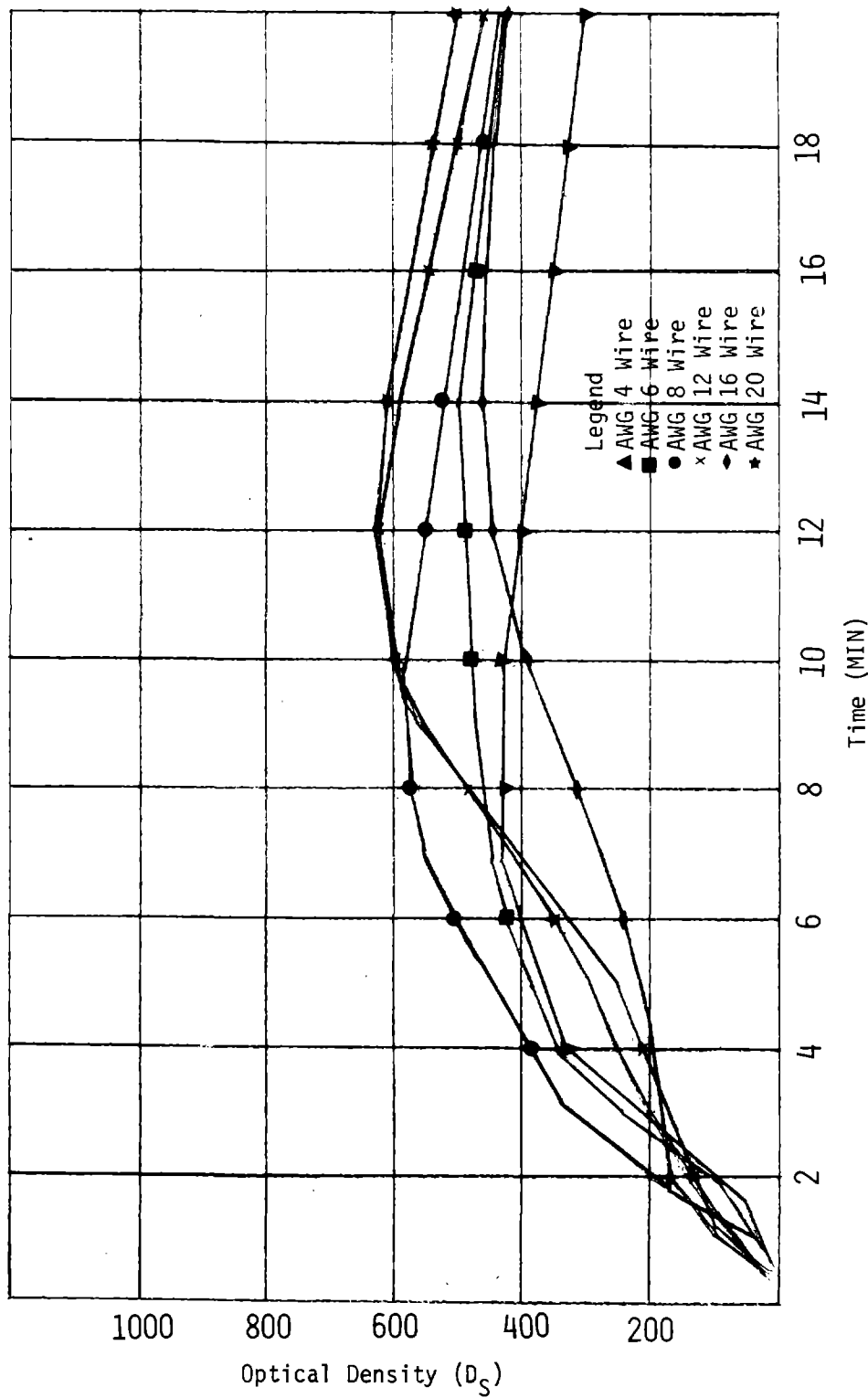

FIGURE 4-12. SMOKE DENSITY VERSUS INSULATION MASS

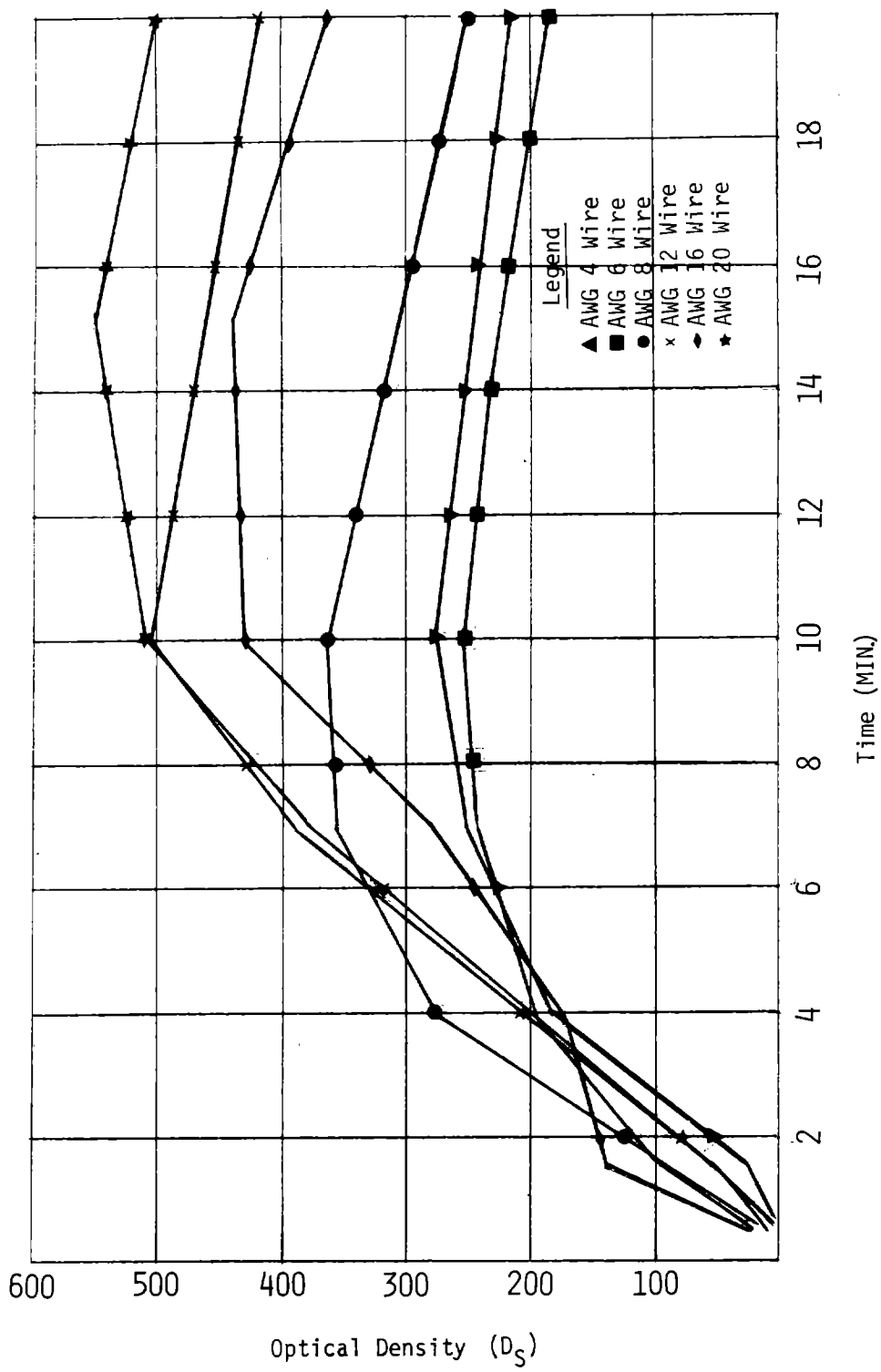

FIGURE 4-13. SMOKE DENSITY VERSUS CONDUCTOR MASS

for D_m for different wire sizes produced further consideration of this approach. The final approach investigated was to generate the smoke as a result of current overload rather than by flame or external radiation sources. The results of this test showed a wide spread in D_m values, and since the test did not offer any advantages over the constant insulated surface area and constant insulation mass, the test method was not pursued.

As a result of all the exploratory testing, it was concluded that both the 'equivalent surface area' and 'equivalent insulation mass' methods were suitable candidates for further evaluation. All of the other methods were discarded for the reasons mentioned. It should be noted that an additional impetus was provided for abandoning current overload testing by the APTA Advisory Board.

Unfortunately, time did not allow for a thorough study of the equivalent surface area and equivalent insulation mass to be completed prior to starting the actual wire and cable tests. A compromise was reached by using both methods on the test specimens with the thought that further analysis of the methods could be one of the products of the actual test phase.

4.2.5 Smoke Emission Test Procedure

All specimens are to be tested in triplicate. Cut 10 feet of AWG 20 wire from supply reel. Measure OD of AWG 20 wire using micrometer and calculate the surface area of 10 ft specimens. Remove approximately 1 inch of insulation. Measure exact length, weigh, and then calculate insulation mass per unit length. Calculate insulation mass for 10 ft of AWG 20. Using the surface area and insulation mass data, calculate equivalent surface area and equivalent insulation mass of each size of wire to be tested. For sizes AWG 10 and smaller, cut the specimens to correct length in one continuous piece. For sizes AWG 8 through 4/0, cut specimens into 3 inch segments. For MCM size cables, remove a length of the insulation and cut 3" x 3" squares.

Wind test specimens (AWG 10 and smaller) on comb and mount in holders. Stack 3 inch segments (sizes AWG 8 through 4/0) parallel to each other in holder. Flatten 3 inch squares and mount in holder. If required to maintain flattened configuration, use stainless steel screen in holders. Condition all specimens a minimum of 24 hours (50% RH and 72°F).

Calibrate NBS chamber radiometer to provide 2.5 watts per square centimeter. Ignite gas burners and calibrate gas flow to provide 16 cc/minute. Determine gas sampling tubes required for the insulation material being tested. Set controls to initiate gas sampling at 4 minutes after start of test. Calibrate each port for flow rate and duration of sampling time. Clean the photocell and lamp lenses and calibrate "zero" setting of instrument.

Secure mounted specimens from conditioning chamber and place on rack in chamber. Position specimen holder in place, close chamber door, close vents, and press "on" button activating chart recorder. Test 20 minutes. When gas sampling is initiated (at 4 minutes), verify correct flow and adjust if required. Monitor instrument during 20 minute test and make range changes as required.

At conclusion of 20 minute test period, actuate lever moving specimen on rack away from the flame and radiometer. Press "stop" button and open vents to evacuate chamber. When chamber is evacuated, open door and remove specimen holder, placing it in ventilating hood to cool.

4.2.6 Pass/Fail Criterion

Establishing an exact value for the pass/fail criterion applicable to the smoke emission characteristics of electrical wire and cable was not considered an appropriate result of this study. The rationale for this statement is that if a single value were chosen it would have to satisfy the most stringent requirements, i.e., wire and cable installed in a underground vehicle or tunnel in which little or no draught could be created in case of fire or collision. This would mean that a large number of insulation materials and constructions which are perfectly capable of providing satisfactory performance in less stringent locations, e.g., above-ground wayside installations, would be eliminated. In other words, the problem of selecting an electrical wire and cable based on smoke emission characteristics is a system problem, and the type of insulation selected can depend a great deal on the environment in which the system will operate.

As will be seen as a result of analysis of the test results, electrical insulations can generally be categorized as low smoke emitters, medium smoke emitters, and heavy smoke emitters, the ranges of maximum specific optical densities for these three

categories falling roughly in the regime 0-50 for low smokers, 50-150 for medium smokers, and greater than 150 for heavy smokers. When the specific optical density is observed at some time, such as 4 minutes, after the beginning of a test, a different set of ranges may be required. Therefore, rather than impose a pass/fail criterion in the interpretation of the test results, it was decided to assign each of the materials/constructions to one of the three categories discussed above.

4.3 Toxicity Test

The initial approach adopted by the contractor was to sample the gases emitted as a result of the smoke testing, identify the gases present, and estimate the percentage content of these gases in the smoke. This approach was predicated first on the fact that there is little agreement within the scientific community regarding the conclusions which can be drawn as a result of exposing small animals to smoke, and secondly, on the available funding versus the potential cost of small animal testing in relationship to the overall program. Subsequent to the program conducted by the contractor, DOT/TSC awarded a contract to the Civil Aeromedical Institute (CAMI), Oklahoma City, to conduct small animal testing of wire and cable materials and constructions supplied to CAMI by the contractor. An executive summary of the report on the CAMI contract has been included as an addendum to this report.

4.4 Circuit Integrity Test Methods

When a rapid transit vehicle is exposed to a fire environment, it is essential to the safety of the passengers that certain critical electrical circuits continue to function. A brief general definition of a critical circuit is as follows:

A critical circuit on a rail transit vehicle or wayside is defined as any circuit whose function is necessary to safely evacuate the passengers and crew from a rail transit car or tunnel in the event of a fire on a car and/or adjoining cars or in the tunnel. The circuit/circuits shall be required to function while experiencing a fire condition for the minimum time to perform the evacuation. Generally, lighting, control, communications, and alarm systems are considered critical circuits. However, in some instances, the propulsion circuitry could

also be considered critical when the car/train is midway between stations when fire is discovered and it must continue to a point where the fire can be extinguished.

It may not be necessary to treat a circuit/system as 'critical' if a backup circuit/system is treated as a critical circuit/system. For example, an emergency battery-powered lighting system (battery, wiring, lights, controls, etc.) must be capable of withstanding the rigors of the emergency (critical circuits) for the required time. If not, the emergency system is not what its name implies.

4.4.1 Approach

The approach employed was similar to that employed for flammability and smoke emission testing, i.e., test selection criteria were established, and various test methods of circuit integrity testing were compared with one another and against the selection criteria. The method which best met the criteria was selected.

4.4.2 Test Selection Criteria

The following criteria were used to select the most appropriate circuit integrity test, which should

Be capable of detecting the electrical integrity of the circuit and measure the time during which circuit integrity is maintained.

Be an existing method or a modification of an existing method.

Provide repeatable results from test to test and from laboratory to laboratory.

Be capable of testing a wide range of wire sizes, i.e., 20 AWG - 2000 MCM.

Be low in cost, i.e., it should not require high cost equipment/facilities and should not use large amounts of wire.

Be simple to conduct.

Simulate the installation.

Not all of these criteria are of equal importance. Therefore, weighting factors were assigned using the method described in Appendix A. The result is shown in Table 4-11.

TABLE 4-11 CIRCUIT INTEGRITY SELECTION CRITERIA WEIGHTING FACTORS

Criteria	Weighting Factor
Integrity Characteristics	.285
Repeatability	.238
All Sizes	.190
Any Laboratory	.143
Low Cost	.095
Existing Method	.048
Simulate Installation	0

4.4.3 Analysis of Existing Test Methods

Three existing candidate circuit integrity tests were reviewed. These were a test referenced by the Boston Insulated Wire (BIW) Company, (which was originally suggested by Dr. Irving Litant of the DOT/TSC), IEEE-383-74, and MIL-W-25038, "Wire, Electrical, High Temperature & Fire Resistant, Aircraft".

Details of the BIW test are shown in Figure 4-14. As can be seen from the figure, the required test equipment is minimal, requiring only slight modification of the setup used for flammability testing. The test consists of exposing a single wire to a flame and measuring the time that elapses before the ring cuts through the insulation and comes in contact with the wire conductor. This method has the advantage of being simple and inexpensive. The disadvantage is that it is applicable to single wires only.

The IEEE-383 test has the advantage that it can be used to detect loss of dielectric integrity between individual wires contained in a cable. As written in IEEE-383 (see Appendix C for details), it is costly and requires a special test chamber and large amounts of wire.

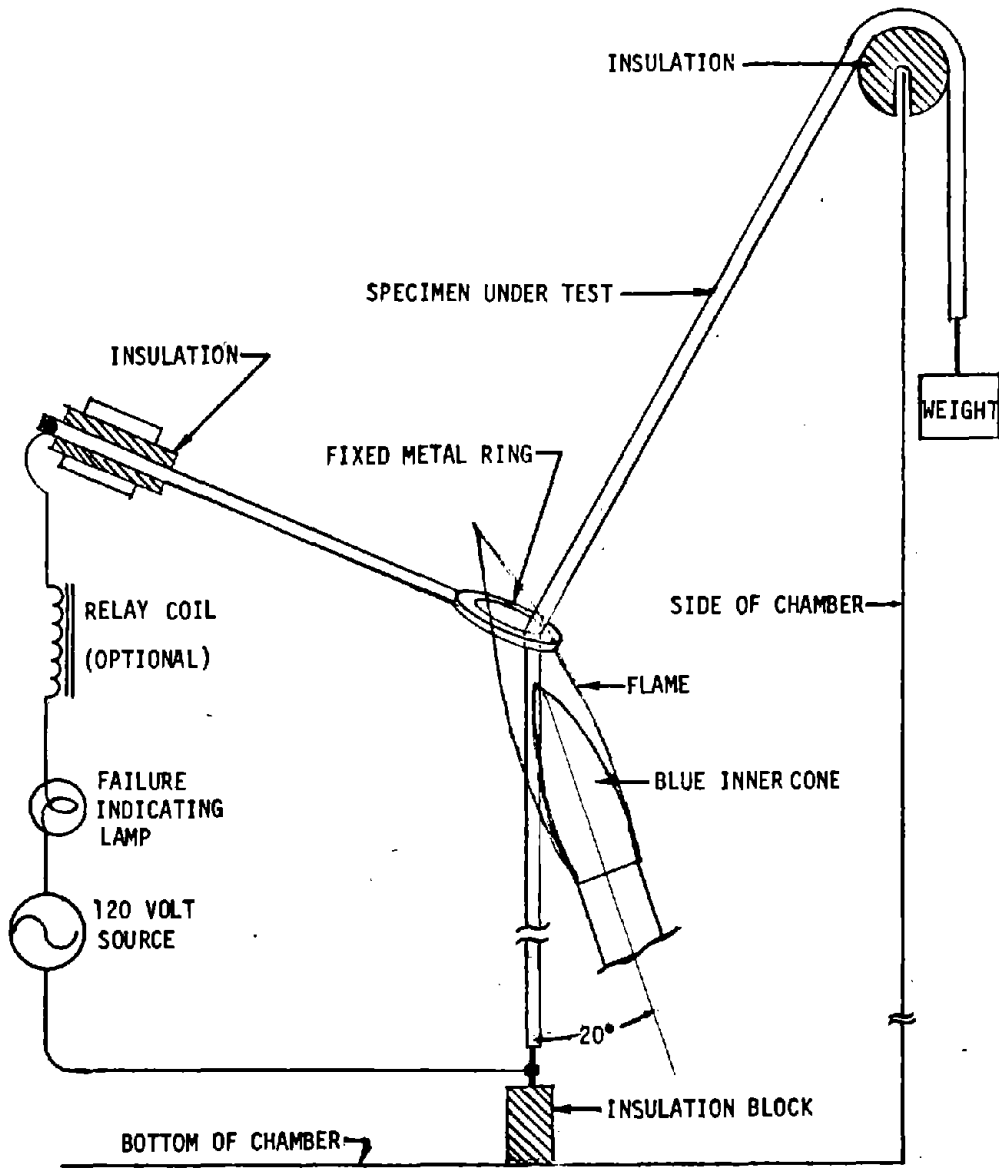

NOTE: For a large wire, it may be desirable to secure the sample at the top end and hang a weight on the bottom.

FIGURE 4-14. BIW CIRCUIT INTEGRITY TEST SETUP

The MIL-W-25038 test setup as shown in Figure 4-15 is an excellent test in that it provides a measure of circuit integrity when exposed to a combined fire-vibration environment, which could be expected on a moving vehicle. However, the test requires an expensive setup and is difficult to run.

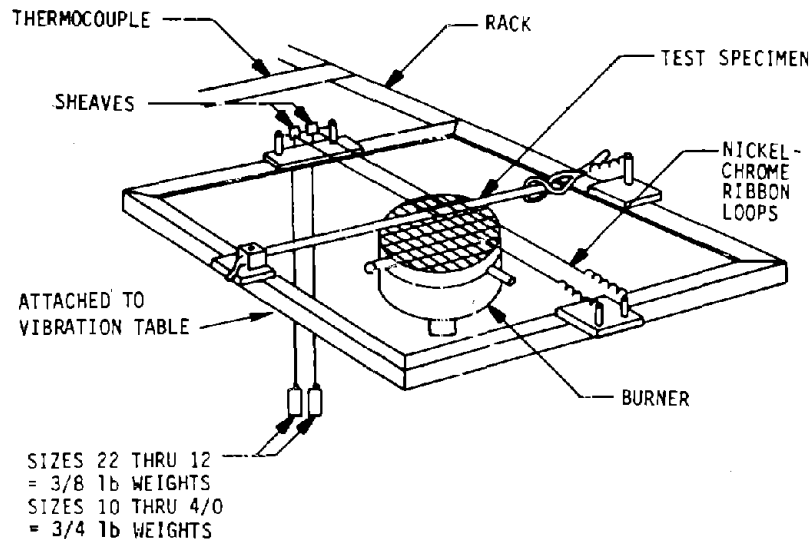

FIGURE 4-15. MIL-W-25038 CIRCUIT INTEGRITY TEST

4.4.4 Selection of Test Methods

A critical circuit on a rail transit vehicle or wayside is defined as any circuit whose function is necessary to safely evacuate the passengers and crew from a rail transit car or tunnel in the event of a fire on a car and/or adjoining cars or in the tunnel. The circuit/circuits shall be required to function while experiencing a fire condition for the minimum time to perform the evacuation. Generally, lighting, control, communications, and alarm systems are considered critical circuits. However, in some instances, the propulsion circuitry could also be considered critical if the car/train is found to be on fire midway between stations and it must continue to a point where the fire can be extinguished.

Since insufficient emphasis was placed on the definition or identification of critical circuits by the rapid transit industry, it was not possible to warrant selection of the MIL-W-25038 test. Therefore, the circuit integrity tests selected were the BIW test for single wires and modification (miniaturization) of the IEEE-383 test to make it compatible with the flammability test setup for multiconductor cables.

4.4.5 Circuit Integrity Test Procedures

4.4.5.1 Single Conductor Wire

APPARATUS

TEST CHAMBER	<ul style="list-style-type: none">- Sheet metal enclosure approximately 12 in. (30.5 cm) x 12 in. (30.5 cm) x 24 in. (61 cm) H.- Shall be open at the top and one vertical side.- Shall have provisions for locating burner in the proper position.
BURNER	<ul style="list-style-type: none">- Bunsen/Tirrill type, 4 in. with 3/8 in. bore.
FLAME	<ul style="list-style-type: none">- Five in. with 1-3/4 in. blue cone with temperature of $954 \pm 28^{\circ}\text{C}$ ($1750 \pm 50^{\circ}\text{F}$).
GAS	<ul style="list-style-type: none">- Natural gas at a pressure of 6 in. (15.2 cm) of water.
CLOCK	<ul style="list-style-type: none">- Digital clock indicating seconds or clock with hand that makes at least one revolution for each minute of elapsed time.
METAL RING	<ul style="list-style-type: none">- A 1 in. (2.5 cm) I.D. ring of approximately 0.2 (.5 cm) cross-sectional diameter material.
DETECTION CIRCUIT	<ul style="list-style-type: none">- 120 volt supply and lamp.

The test setup is illustrated in Figure 4.14.

PROCEDURE

The test specimen must be conditioned to $21 \pm 3^{\circ}\text{C}$ ($70 \pm 5^{\circ}\text{F}$) and at $50 \pm 5\%$ relative humidity for a minimum of 24 hours. Only one specimen at a time shall be removed from the conditioning environment immediately before subjecting it to this test.

The test shall be made in a room which is generally free from drafts of air, although a ventilated hood may be used if air currents do not affect the flame. One end of the test specimen, approximately 22 in. (55.9 cm) in length, shall be held in position at the bottom of the chamber, passing through a fixed 1 in. diameter metal ring located approximately 2-1/2 in. (6.35 cm) above a Bunsen burner and over an insulated portion of the upper sidewall where it is loaded with a weight which varies for different wire sizes as shown in Table 4-12. A 120 volt power supply shall be connected in series with the metal ring, test specimen, and a lamp with the insulation of the specimen preventing completion of the electrical circuit at the metal ring-test specimen intersection. Insulation failure will complete the circuit. The electrical circuit may also include a relay coil used to stop an electric clock.

TABLE 4-12 WIRE SIZES AND CORRESPONDING LOAD WEIGHTS

Wire Size (AWG)	Load Weight (lbs)
20 - 18	1
16 - 14	2
12 - 8	3-1/2
6 - 2	5
>2	10

The burner flame shall be adjusted to deliver the specified flame with the given gas pressure. The burner shall be placed under the sample so that the vertical plane through the stem of the burner includes the axis of the wire or cable. The angle block shall rest against the jig which shall be adjusted so that the flame impinges on the specimen 0.8 in. (2.0 cm) below the ring. The flame shall then be applied to the sample. The time taken for the lamp to light, thus indicating electrical contact between the ring and the conductor, shall be recorded.

All of the data shall be recorded in the data sheet shown in Figure 4-16.

CIRCUIT INTEGRITY TEST DATA

Material Description

Manufacturer/ Supplier

Wire Size _____ AWG _____ MCM

Test Date

Test Location

Tested By

Burner Type

Bunsen
Fisher

Gas Pressure _____ in. H₂O

Flame Temp. _____ °F

TIME TO ELECTRICAL FAILURE

SPECIMEN NO.	MIN.	SEC.	COMMENTS

ADDITIONAL COMMENTS: NONE

4.4.5.2 Multiconductor Cable

APPARATUS

TEST CHAMBER	<ul style="list-style-type: none">- Sheet metal enclosure approximately 12 in. (30.5 cm) x 18 in. (45.7 cm) x 24 in. (61 cm) H.- Shall be open at the top and one vertical side.- Shall have provisions for locating the burner and test specimen in the proper position.
BURNER	<ul style="list-style-type: none">- Fisher burner with 1-1/2 in. (4 cm) diameter grid.
FLAME	<ul style="list-style-type: none">- Adjust so that small cones between grid openings are approximately 1/8 in. (3.2 mm) high, the nonluminous flame is 8 to 9 in. (20-23 cm) high, and the temperature is $982 \pm 28^{\circ}\text{C}$ ($1800 \pm 50^{\circ}\text{F}$).
GAS	<ul style="list-style-type: none">- Natural gas at a pressure of 6 in. (15.2 cm) of water.
CLOCK	<ul style="list-style-type: none">- Digital clock indicating seconds or a clock with a hand that makes at least one revolution for each minute of elapsed time.
FAILURE DETECTION	<ul style="list-style-type: none">- An electric circuit to provide detection of conductor to conductor insulation failure.

The test setup is illustrated in Figure 4-17 and the electrical detector circuit diagram is illustrated in Figure 4-18.

PROCEDURE

A test specimen approximately 24 in. (61 cm) long shall be conditioned to $21 \pm 3^{\circ}\text{C}$ ($70 \pm 5^{\circ}\text{F}$) and 50 ± 5 percent relative humidity for a minimum of 24 hours. The specimen shall remain in the conditioning environment until immediately before testing.

The test shall be conducted in a room generally free from drafts of air, although a ventilated hood may be used if air currents do not affect the flame. Mount the test specimen as shown in Figure 4-17. The radius "R" should not be less than 4 in. (10 cm). Means of support should be provided to position the cable as shown. The flame from the burner should be directed at the cable at a point 30 degrees below

CHAMBER 12 IN. X 18 IN. X 24 IN.
OPEN FRONT AND TOP

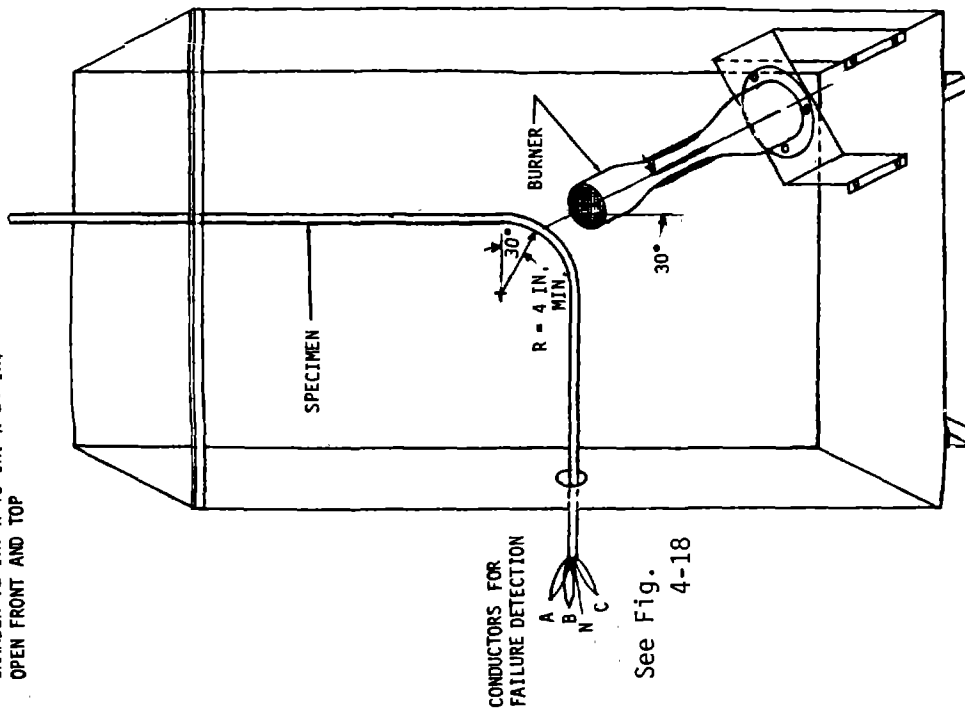

See Fig.
4-18

FIGURE 4-17. MULTICONDUCTOR CABLE
FLAMMABILITY/INTEGRITY TEST SETUP

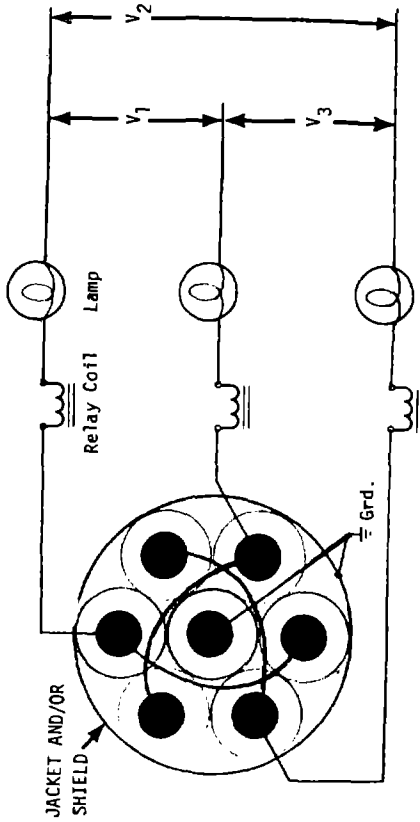

THREE PHASE DETECTION CIRCUIT
($V_1 = V_2 = V_3$)

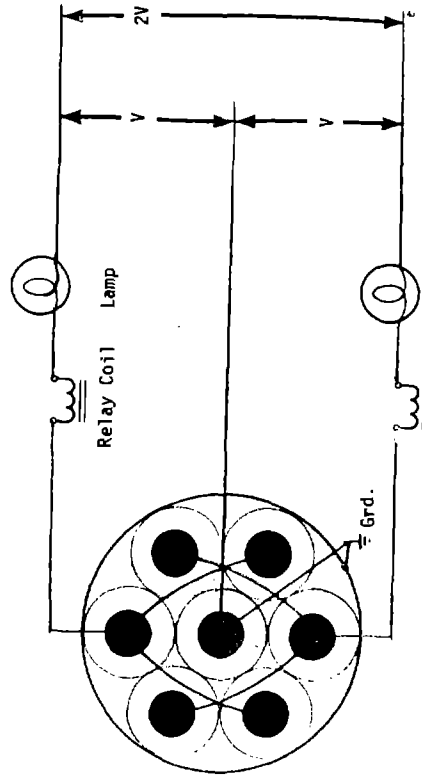

SINGLE PHASE DETECTION CIRCUIT

FIGURE 4-18 FAILURE DETECTION CIRCUITRY

where the radius "R" is horizontal (see Figure 4-17). The burner should be mounted in the plane of the specimen undergoing test and tilted 30° from vertical toward the specimen.

A circuit consisting of either a three phase (four wire) or a single phase (three wire 240/120 volt) power supply and three lamps, connected as shown in Figure 4-18 should be used to detect an insulation failure. An optional feature would be to include relay coils in each leg of the circuit which would stop a timing clock automatically upon insulation failure.

The flame should be applied to the specimen and not removed until at least one failure has been indicated by the failure sensing circuit or 30 minutes have elapsed, whichever is first. The precise time of failure shall be recorded as well as all data regarding flame propagation, smoke output, and anything else of significance.

The results of the test shall be recorded in the data sheet shown in Figure 4-19.

4.4.6 Circuit Integrity Pass-Fail Criteria

Circuits requiring special integrity are usually considered those associated with the safe evacuation of passengers in the event of a fire and are found in alarm, communication, control, traction, and lighting systems. The time that the wiring should withstand exposure to flame without failure is directly related to the minimum time required to evacuate the passengers.

It is beyond the scope of the study reported in this document to address the subject of the various methods by which the safety of passengers can be assured in a fire environment, the time it takes to transport these passengers to a safe environment, or the specific design methods employed by rapid transit system designers and operators. Therefore, no pass/fail criteria have been established as a means of categorizing the wire and cable tested. Rather, the ranking of the critical circuit capability of the wire and cable will be based on the time during which electrical circuit integrity can be preserved.

MULTIPLE CONDUCTOR CABLE CIRCUIT INTEGRITY TEST DATA SHEET

Sheet No. _____

Material Description	Wire Size _____ AWG _____ MCM
Manufacturer/Supplier	Burner Type <input type="checkbox"/> Bunsen <input type="checkbox"/> Fisher
Gas Pressure _____ 6.0 _____ In. H ₂ O	Differential Pressure _____ In. H ₂ O
Flame Temp. _____ °F	

Test Date / /	Tested By _____
---------------	-----------------

Specimen No.	1	2	3	4	5	6	Average
Time to first failure (Min: Sec)							
Time to second failure (Min : Sec.)							
Time to ignition (Seconds)							

Did:

Specimen drip?	Yes							
	No							
Burning particles fall?	Yes							
	No							
Specimen convey flame to cotton pad?	Yes							
	No							

Burn Area:

Distance from Q of burner	Above							
	Below							

Smoke:

<input type="checkbox"/> Heavy	<input type="checkbox"/> Moderate/Heavy	<input type="checkbox"/> Moderate	<input type="checkbox"/> Light/Moderate	<input type="checkbox"/> Light	<input type="checkbox"/> None Observed
<input type="checkbox"/> Black	<input type="checkbox"/> Black/Gray	<input type="checkbox"/> Gray	<input type="checkbox"/> Gray/White	<input type="checkbox"/> White	

Comments:

5.0 TEST PROGRAM

The purpose of conducting the test program was twofold:

To determine if the test methods discussed in Section 4.0 were meaningful and practical.

To provide data which could be used to rank the insulation materials and wire and cable constructions in terms of their performance in a fire environment.

5.1 Test Samples

Wire and cable samples were requested from all wire and cable manufacturers who had in some manner given an indication that they were interested in participating in the test program. Samples of wire insulated with the present state-of-the-art materials as well as new or advanced materials were requested. Specific insulating materials and constructions were not requested. The selection of materials and constructions was left entirely to the participating manufacturers, the reason being that if the manufacturer was to contribute a sizeable amount of wire for test, he should be allowed to select the material which would provide him the best probability of passing the tests performed on the wire. Due to this approach, several materials were not included in the samples that are presently being used by the transit industry.

Because of the deficiency in the test sample population, numerous insulating materials in use today were not included among the samples submitted by wire manufacturers. The APTA Advisory Board appealed to and received from their membership an additional twenty-five wire and cable samples insulated with materials specifically desired to be included in the tests.

Table 5-1 contains a list of all of the suppliers who contributed samples. It should be recognized that these samples were delivered free of charge and represent a considerable investment on the part of the wire and cable manufacturers, as can be seen from the requested sample lengths listed in Table 5-2.

TABLE 5-1. SAMPLE SUPPLIERS/MANUFACTURERS

SUPPLIER	MANUFACTURER
Boeing Vertol Company	Anaconda - Continental Wire and Cable Co.
Boston Insulated Wire and Cable Co.	BIW
British Insulated Calendar's Cables, Ltd.	BICC
Cerro Wire and Cable Co.	Cerro
E. I. dePont deNemours Co.	Haveg Industries, Inc.
Filotex	Filotex
General Electric, Wire and Cable	GE
Harbour Industries, Inc.	Harbour
Haveg Industries, Inc.	Haveg
Industrial Wire and Cable	IWC
ITT, Suprenant Division	ITT
Mili Bride, Inc.	Mili Bride
Prestolite Wire Division	Prestolite
Tensolite Company	Tensolite
Bay Area Rapid Transit District	Alpha Wire Corporation
Chicago Transit Authority	A.I.W. Corp, Tensolite Co., and two unknowns
Massachusetts Bay Transportation Authority	Collier Cable Co., Rome Cable Co., and U. S. Steel Corporation
Montreal Urban Community Transit Commission	Canada Wire and Cable, Northern Electric Co. and Phillips Cables, Ltd.
New York City Transit Authority	Allied Chemical Co., ITT, Suprenant Div. Okonite Wire and Cable Corporation and the Kerite Company
The Port Authority of NY and NJ	Anaconda-Continental Wire and Cable
Washington Metropolitan Area Transit Authority (Bechtel Associates Professional Corporation)	Andrew Corporation, Okonite Wire and Cable Corporation, Phelps Dodge Cable and Wire Co., and Superior Cable Co.

An attempt was made to reduce the number of wire sizes to be tested by picking those that were representative of the whole range of sizes used in the industry.

TABLE 5-2 SAMPLES REQUESTED

Size (AWG)	Quantity (ft)
*20	1500
16	1500
12	1500
8	1500
4	500
2/0	500
500 MCM	500
7 Cond./12 AWG	500

* or the next larger size, if 20 is not available

BICC Pyrotenax, Ltd. went to considerable trouble and expense to prepare and ship to The Boeing Company twenty-four samples. The samples were no doubt of high quality but were rigid materials (not flexible) and were not deemed the type of materials that this contract has commissioned The Boeing Company to include in testing. Our apologies to BICC Pyrotenax, Ltd.

Tables 5-3, 5-4 and 5-5 show the distribution of the size, insulation material and construction of the wire and cable samples received from manufacturers and from APTA.

5.2 Test Sample Identification

Identification codes were developed for all wire samples. The purpose of these codes was to preclude judgement of performance based on prejudices for one manufacturer over another. This method was not foolproof since some of the samples were manufactured with brand names, manufacturer, or other identification means.

TABLE 5-3. SINGLE CONDUCTOR SAMPLES CATEGORIZED BY WIRE SIZE

AWG or MCM	NO. OF SAMPLES
20	22
18	1
16	14
14	9
12	3
10	1
8	9
6	1
4	5
3	1
2	1
2/0	7
3/0	1
250	1
500	5
1000	1
2000	1

TABLE 5-4. SINGLE CONDUCTOR SAMPLES CATEGORIZED BY INSULATION MATERIAL

INSULATION MATERIAL	NO. OF SAMPLES
Asbestos	1
Ethylene Propylene Rubber (EPR)	1
Halar	1
Hypalon	1
Mica	1
Kapton	10
Polyester	2
Polyethylene	3
Polyolefin	12
Polyvinyl Chloride (PVC)	10
Silicone Rubber	12
Teflon	8
Tefzel	11
Thermoplastic	2
EPR/Hypalon	1
EPR/PVC	1
Rubber/Lead	1
Synthetic Rubber/Neoprene	3
Teflon/Asbestos	1
Thermoplastic/Nylon	1

TABLE 5-5. MULTICONDUCTOR CABLE SAMPLES

CONDUCTORS/SIZE(AWG)	INSULATION MATERIAL
2/16	Silicone Rubber/Silicone Rubber
3/16	Tefzel/S/Tefzel
4/12	Silicone Rubber/Glass
6/19	Polyethylene/S/Polyethylene
7/20	Kapton/(No Jacket)
7/20	Tefzel-H Coat/(No Jacket)
7/14	Mica Tape-Teflon(FEP)/Teflon (FEP)
7/14	Mica Tape-Tefzel/Tefzel
7/14	Halar/Halar
7/14	Polyolefin/Polyolefin
7/14	Synthetic Rubber/Neoprene
7/12	Kapton-H Coat/Kapton
7/12	Polyethylene/Neoprene
7/12	Polyethylene/Polyethylene
7/12	Polyolefin/Polyolefin
12/19	Polyethylene/Polyethylene
19/12	Tefzel/Neoprene
24/19	Polyethylene/S/Polyvinyl Chloride
148/19	Polypropylene/S/Polyethylene/PVC
"S" indicates a metallic shield.	

The identification scheme developed utilized three groups of digits to identify the wire manufacturer, wire gauge, and, generally, the materials provided by that manufacturer. For example, 1-20-3. The "1" is the supplier/manufacturer identification. The middle number is the wire gauge: 20 = AWG 20, 00 = AWG 2/0, and 500 = 500 MCM. For cables the middle number would be in the form, 7X12; the 7X indicates 7 individual insulated conductors and the 12 indicates that each conductor was a 12 AWG wire. The last number indicates that in this case, this is the third material furnished by the same manufacturer.

In retrospect it would have been preferable if the third group had been assigned serially so that each material was identified rather than indicating that the manufacturer sent more than one material. Thus, each time a "1" appeared, it would be known what the material was, e.g., silicone, while a "10" might mean PTFE.

The supplier identification code is shown in Table 5-6, and a complete list of all samples tested, the identification code for each sample, and the general description of the insulating material/construction are contained in Tables 5-7A and 5-7B.

5.3 Flammability Tests

5.3.1 Burner Considerations

In all flammability and circuit integrity tests involving a burner, special attention was given to the natural gas pressure, flame height, and gas consumption of the burner. Periodic checks were made on the maximum temperature of the flame and air flow through the test chamber. Some standard tests that were reviewed recommended the use of a burner incorporating a pilot light so that the flame could be removed from the test specimen by turning off the gas supply and reapplied by turning the gas supply back on. It was found by experience that a much more accurate test could be conducted by physically removing the burner and moving it back at the proper time. The flame does not extinguish at the exact time of shutoff nor does it ignite at the exact time the gas is restored. The flow rate changes also as the burner is warmed up. In the tests conducted under this contract, the burners were mounted on a hinged plate which would allow the burner to be lifted away from the specimen without disturbing the flame. This hinged plate is illustrated in Figure 5-1. The flame was adjusted for the proper parameters, and when all were stable, it was applied to the test specimen.

TABLE 5-6. SUPPLIER IDENTIFICATION CODE

SAMPLE NUMBER	SUPPLIED BY:	MANUFACTURED BY:
Beginning With		
1-	Boston Insulated Wire & Cable Co.	BIW
2-	Cerro Wire and Cable Co.	Cerro
3-	Filotex	Filotex
4-	General Electric, Wire and Cable	GE
5-	Harbour Industries, Inc.	Harbour
6-	Haveg Industries, Inc.	Haveg
7-	Unassigned	
8-	Mili Bride, Inc.	Mili Bride
9-	Prestolite Wire Division	Prestolite
10-	Tensolite Company	Tensolite
11-	ITT, Suprenant Division	ITT
12-	Industrial Wire & Cable	Industrial
13-	E.I. duPont deNemours Co.	Haveg Industries, Inc.
14-	British Insulated Calendar's Cables,Ltd.	BICC
15-	Boeing Vertol Company	Anaconda-Continental Wire & Cable Co.
A1-14-1	Bay Area Rapid Transit District	Alpha Wire Corp.
A2-14-1	Chicago Transit Authority	Unknown
A2-14-2	Chicago Transit Authority	A.I.W. Corp.
A2-250-2	Chicago Transit Authority	Unknown
A2-19x12-3	Chicago Transit Authority	Tensolite Company
A2-6/2x19-4	Chicago Transit Authority	Unknown
A3-7x14-1	New York City Transit Authority	Okonite Wire and Cable Corp.
A3-7x14-2	New York City Transit Authority	The Kerite Company
A3-2000-3	New York City Transit Authority	Unknown
A3-7x14-4	New York City Transit Authority	Allied Chemical Co.
A3-7x14-5	New York City Transit Authority	ITT, Suprenant Division
A4-500-1	Massachusetts Bay Transportation Authority	United States Steel Corp.
A4-500-2	Massachusetts Bay Transportation Authority	Collier Cable Company
A4-1000-3	Massachusetts Bay Transportation Authority	Rome Cable Company
A5-14-1	Montreal Urban Community Transit Commission	Northern Electric Co.
A5-14-2	Montreal Urban Community Transit Commission	Northern Electric Co.
A5-00-3	Montreal Urban Community Transit Commission	Phillips Cables, Ltd.
A5-000-4	Montreal Urban Community Transit Commission	Canada Wire and Cable
A5-Mx19-5	Montreal Urban Community Transit Commission	Northern Electric Co.
A6-4x12-1	The Port Authority of NY and NJ	Anaconda-Continental Wire and Cable Co.

TABLE 5-6. CONTINUED

SAMPLE NUMBER	SUPPLIED BY:	MANUFACTURED BY:
A7-2-1	Washington Metropolitan Area Transit Authority	Phelps Dodge Cable & Wire Co.
A7-00-2	Washington Metropolitan Area Transit Authority	Okonite Wire and Cable Corp.
A7-Coax-3	Washington Metropolitan Area Transit Authority	Andrew Corp.
A7-6x19-4	Washington Metropolitan Area Transit Authority	Superior Cable Co.
A7-24x19-5	Washington Metropolitan Area Transit Authority	Superior Cable Co.

TABLE 5-7A. SAMPLE DESCRIPTIVE INFORMATION, SINGLE CONDUCTOR

SAMPLE NUMBER	AWG	STRANDS AWG	INSULATING MATERIALS	OTHER
1-20-1	20	10/30	Silicone Rubber/XLM Polyolefin	600 V, Tinned
3-20-1	20	① 19/.203	Tefzel/Polyimide coat	Tinned
3-20-2	20	① 19/.20	Kapton	Tinned
5-20-1	20	19/32	Tefzel	600 V, 150°C, Tinned
6-20-1	20	7/28	XL Polyolefin	600 V, Tinned
9-20-1	20	19/32	Polyester	105°C, Tinned
9-20-2	20	19/32	Silicone Rubber/Glass Braid-Hi-Temp. Lacquer	600 V.
10-20-1	20	—	Extruded Teflon (PTFE)	1000 V.
10-20-2	20	—	Kapton/Polyimide Coat (MIL-W-81381/11)	200°C, 600 V.
11-20-1	20	19/32	XL Polyolefin	—
12-20-1	20	19/32	Teflon (EE)	Silverplated
12-20-2	20	19/32	Teflon (TFE)	Silverplated
13-20-1	20	—	Kapton/Polyimide Coat (MIL-W-81381/12 except tinplated)	—
14-20-1	20	1	Polyvinyl Chloride (General Purpose Insulation Grade)	—
14-20-2	20	1	Polyvinyl Chloride (General Purpose Sheathing Grade)	—
14-20-3	20	1	Polyvinyl Chloride (Acid-binding Compound)	—
14-20-4	20	1	Polyvinyl Chloride (Reduced-propagation Compound)	—
14-20-5	20	1	Polyethylene (Mineral filled)	—
14-20-6	20	1	Polyvinyl Chloride (Reduced Smoke and Propagation Compound)	—
14-20-7	20	① 19/20	Teflon (PTFE)	—
14-20-8	20	② 19/.0076	Silicone Rubber/Glass Braid/Terylene - Lacquered Orange	—
14-20-9	20	① 19/.020	Kapton/Teflon (FEP) Tape	—
10-18-3	18	—	Tefzel	1000 V.
1-16-1	16	26/30	Silicone Rubber/XLM Polyolefin	600 V, Tinned
4-16-1	16	19/29	XL Polyvinyl Chloride	1000 V, Tinned
5-16-2	16	26/30	Teflon/Asbestos/Glass Braid	600 V, 250°C, Nickel Coated
5-16-3	16	26/30	Silicone Rubber/Glass Braid	Tinned
6-16-1	16	26/30	XL Polyolefin	600 V, Tinned
8-16-1	16	19/29	Tefzel	—
9-16-1	16	19/29	Polyester	105°C, Tinned
9-16-2	16	19/29	Silicone Rubber/Glass Braid-Hi-temp Lacquer	Tinned
10-16-1	16	—	Extruded Teflon (PTFE)	1000 V.
10-16-3	16	19/29 ⁸	Tefzel	1000 V, Tinned
11-16-1	16	19/29	XL Polyolefin	—
12-16-3	16	19/29	Tefzel	Tinned
13-16-1	16	—	Kapton/Polyimide Coat (MIL-W-81381/12 except tinned)	—

① Diameter of individual strands in millimeters.
② Diameter of individual strands in inches.

TABLE 5-7A. CONTINUED

(Sheet 2)

SAMPLE NUMBER	AWG	STRANDS AWG	INSULATING MATERIALS	OTHER
14-16-7	16	① 19/.287	Teflon (PTFE)	Silverplate
14-16-8	16	② 40/.0076	Silicone Rubber/Glass Braid/Terylene-Lacquered Orange	Nickel Plated
2-14-1	14	-	Asbestos/Teflon/Glass Braid	399°C, 600V, Nickel Clad
2-14-2	14	-	Mica/Glass Braid-Silicone	1200°F; 600V, Nickel Clad
10-14-2	14	-	Kapton/Polyimide Coat (MIL-W-81381/11)	200°C, 600 V
14-14-10	14	① 50/.25	Silicone Rubber	Tinned
A1-14-1	14	-	Irradiated Polyvinyl Chloride	-
A2-14-1	14	1	Thermoplastic/Nylon (THHN)	600 V.
A2-14-2	14	1	Thermoplastic (THW)	600 V.
A5-14-1	14	-	Ethylene Propylene Rubber/Hypalon	1000 V.
A5-14-2	14	-	Ethylene Propylene Rubber	-
12-12-3	12	19/ -	Tefzel	Tinned
12-12-4	12	19/ -	Halar	Tinned
12-10-3	10	19/ -	Tefzel	Tinned
1-8-1	8	168/30	Silicone Rubber/XLM Polyolefin	2000 V, Tinned
3-8-1	8	① 127/.30	Tefzel/Polyimide Coat	Tinned
3-8-2	8	① 127/.30	Kapton	Tinned
4-8-1	8	37/24	XL Polyvinyl Chloride	1000 V, Tinned
6-8-1	8	84/27	XL Polyolefin	600 V, Tinned
9-8-2	8	7x19/29	Silicone Rubber/Glass Braid-Hi-Temp Lacquer	600 V, Tinned
10-8-3	8	-	Tefzel	1000 V,
11-8-2	8	-	XL Polyolefin	2000 V
13-8-1	8	84/27	Kapton/Nomex Braid (MIL-W-81381/12 except tinned)	-
11-6-2	6	-	XL Polyolefin	600 V.
1-4-1	4	420/30	Silicone Rubber/SLM Polyolefin	2000 V, Tinned
6-4-1	4	133/25	XL Polyolefin	600 V, Tinned
9-4-2	4	7x19/25	Silicone Rubber/Glass Braid-Hi-Temp Lacquer	600 V, Tinned
10-4-1	4	-	Mineral Filled Teflon (PTFE)	600 V
13-4-1	4	133/25	Kapton/Nomex Braid (MIL-W-81381/12 except Tinned)	-
10-3-3	3	-	Tefzel	1000 V
A7-2-1	2	① -	Thermolene (XL Polyethylene) (XHHW)	600 V
3-00-3	2/0	37x37/.25	Teflon (PTFE)/Kapton/Glass Braid/Teflon (PTFE)	250°C, 600 V, Nickel Plated
6-00-1	2/0	259/23	XL Polyolefin	600 V, Tinned
10-00-3	2/0	-	Tefzel	1000 V,

① Diameter of individual strands in millimeters.

② Diameter of strands in inches.

TABLE 5-7A. CONTINUED

(Sheet 3)

SAMPLE NUMBER	AWG	STRANDS AWG	INSULATING MATERIALS	OTHER
11-00-2	2/0	—	XL Polyolefin	2000 V
15-00-1	2/0	—	Hypalon (Per AAR 589)	1000 V
A5-00-3	2/0	—	XL Polyethylene/Semi-Conductive Jacket/ 14(3/16 x .027) tinned Cu armour over Jacket	
A7-00-2	2/0	—	EPR/Neoprene (RHH or RHW)	600 V
A5-000-4	3/0	—	Butyl Rubber/Chloroprene	-
A2-250-2	<u>MCM</u> 250	38/ —	Thermoplastic (THW) Uncoated Copper	75°C, 600 V
4-500-1	<u>MCM</u> 444	1000/24	XL Polyvinyl Chloride	2000 V, Tinned
10-500-4	500	—	Teflon (FEP)	1000 V
11-500-1	535	1325/24	XL Polyolefin	
A4-500-1	500	—	Synthetic Rubber/Polyvinyl Chloride	
A4-500-2	500	—	Synthetic Rubber/Lead	
A4-1000-3	1000	—	Polyvinyl Chloride (THW)	600 V, Uncoated Copper
A3-2000-3	2000	—	Synthetic Rubber/Neoprene	75°C, 1000 V

TABLE 5-7B. SAMPLE DESCRIPTIVE INFORMATION, MULTICONDUCTOR CABLE

SAMPLE NUMBER	NUMBER OF COND.	COND. AWG.	INSULATING MATERIALS		OTHER
			INDIVIDUAL WIRE/JACKET		
2-2x16-1	2	16	Silicone Rubber/Silicone Rubber		200°C, 300 V
3-7x20-1	7	20	Tefzel/H-Coat/No Jacket		-
3-7x20-2	7	20	Kapton/No Jacket		-
4-7x12-1	7	12	Polyethylene/Polyethylene		-
4-7x12-2	7	12	Polyethylene/Neoprene		-
6-7x12-1	7	12	Polyolefin/Polyolefin		-
12-3x16-1	3	16	Tefzel/Cu Shield/Tefzel		Tinned Conductor and Shield
13-7x14-1	7	14	Mica-Teflon(FEP)/Teflon(FEP)(White)		-
13-7x14-2	7	14	Mica-Tefzel/Tefzel(Black)		-
13-7x12-3	7	12	Kapton-H-Coat/Kapton		-
A2-19x12-3	19	12	Tefzel/Film/Neoprene		-
A2-6/2x19-4	12	19	Polyethylene/Cu Shield/Film/Polyethylene 7 Strand Steel Messenger (Shaped in the form of a Figure "8")		-
A3-7x14-1	7	14	Synthetic Rubber/Neoprene		-
A3-7x14-2	7	14	Proprietary Compound/Cloth Tape/Neoprene		-
A3-7x14-4	7	14	Halar/Halar		-
A3-7x14-5	7	14	Polyolefin/Polyolefin		-
A5-Mx19-5	148	19	Polyethylene/Paper/Al Shield/Polyethylene/PVC-Grease Impregnated		-
A6-4x12-1	4	12	Silicone Rubber-Glass Braid/Mylar Tape/Glass Braid		-
A7-6x19-4	6	19	Polyethylene/Al Shield/Polyethylene/Al Shield/PVC-Grease Impregnated		-
A7-24x19-5	24	19	Polyethylene/Film-Shield/Al Shield/Polyethylene/Al Shield/Polyethylene/PVC-Grease Impregnated.		-
A7-Coax-3	Coax		Foam Dielectric/Cu Slotted Shield/Polyethylene		-



5-1a. Burner and Plate Down During Test

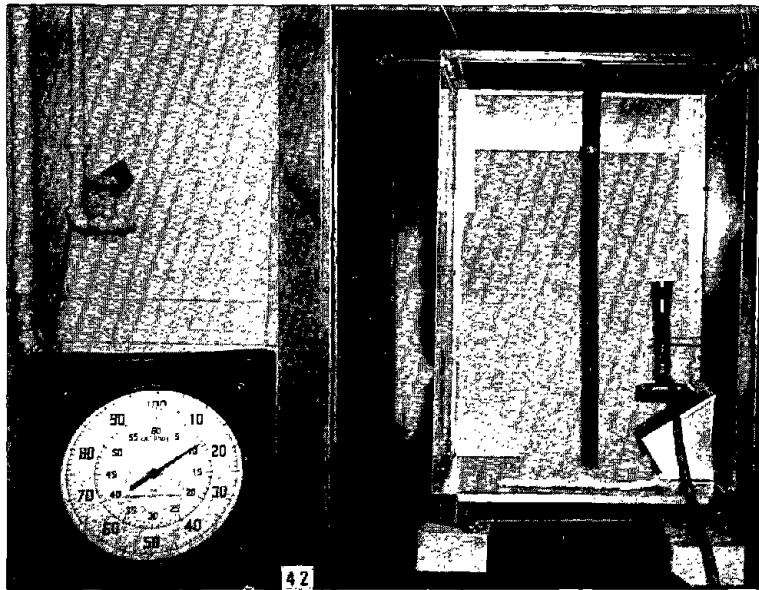

5-1b. Burner and Plate Away from Specimen

FIGURE 5-1. TEST BURNER AND PLATE SETUP

A water manometer was used to continuously monitor the gas pressure. A Venturi tube was used to continuously monitor the flow rate or the consumption of the gas by the burners.

The air velocity through the chamber ranged from 0 to 10 feet per minute with the burner operating.

The burner statistics are shown in Table 5-8.

TABLE 5-8 BURNER STATISTICS

BURNER	ORIFICE DIA. (IN).	GAS PRES.	CU FT. PER HR.	BTU PER HOUR	NOMINAL TEMPERATURE
BUNSEN	0.055	6"H ₂ O	0.9	936	1750 ^o F
FISHER	0.108	6"H ₂ O	1.95	2028	1800 ^o F

The BTU rate was calculated on the basis of 1040 BTU/cu. ft. furnished by the Washington Natural Gas Company. The temperatures were measured by chromel-alumel thermocouple.

5.3.2 Vertical Flammability Test

Samples were tested in accordance with the vertical flammability test procedure described in Section 4.1.5.2 and for the flame exposure time according to their size. In cases where the sample resisted damage by the flame, some samples were exposed for longer periods of time. This was especially true in the larger single conductor wires and multiconductor cables. There is a larger variation in insulation thickness and plies of insulation materials in these types of wire and cable. Some of the materials are very flame resistant while others will melt and flow away from the flame.

Flame exposure times for the test population of AWG 20, 16, 14, 8, and 4 wire was long enough to give reasonable assurance that they are appropriate. However, times for larger wires may need to be revised due to being established from a small number of samples. These times were determined in a way that was considered as fair as

possible for the samples involved. The 2000 MCM sample was tested to the procedure using the Fisher burner. The wire is much too large for this burner. If a test program consisting of more extremely large wires was being conducted, a larger burner would be required.

The flammability tests appropriate to multiconductor cable are generally used for single conductor wires larger than AWG 4. A few multiconductor cables which had no protective jacket were practically destroyed when subjected to this test. Ignition times were observed. This parameter was simply a judgement as to how soon the flame was actually emanating from the test specimen.

Afterflame and/or glow is the time measured from the removal of the gas flame from the specimen until all flaming or glowing is extinguished naturally.

The test specimen is considered to have conveyed flame if either the cotton pad placed below it is ignited or the Kraft paper flame indicator is more than 25 percent consumed by the flame.

The actual flame damage caused to the wire insulation, including any smoke or stain that could not be wiped from the specimen, was measured.

The data described above were collected for each of six test specimens for each sample.

5.3.3 Horizontal Flammability Test

In general, the same problems existed for horizontal tests as for vertical tests. The same parameters were observed, with the exception of the absence of a Kraft paper flame indicator. In addition, a postflame dielectric test was performed on the single conductor wires. The postflame dielectric test results are somewhat confusing because preliminary tests were conducted using a high electrical potential instrument which had a maximum output of 6 kV. As part of earlier tests, the specimen was tested up to 6 kV and held at that potential for 60 seconds. Data were recorded on this basis. In later tests, the specimens were tested on another machine after the 60 second hold, and the potential was further increased to failure.

5.4 Smoke Tests

Smoke tests were performed in the NBS Smoke Chamber.

Preparation of samples consisted of cutting AWG 20 wire to lengths 10 feet long. For each sample submitted, the outside diameter was measured for subsequent use in calculating surface area. A length of insulation was removed from the wire and measured to the nearest 0.001 inch and weighed to the nearest 0.0001 gram. These were used in subsequent calculations of mass per unit length. The formula for calculations of equivalent surface area and insulation mass are as shown in Figure 5-5. Other wire sizes were cut to lengths to provide the equivalent surface area or equivalent insulation mass of 10 feet of AWG 20 wire. For wire sizes smaller than AWG 10, these lengths were one continuous piece. For wire sizes AWG 10 through 2/0, the sample was cut into 3 inch lengths, and then the number of 3 inch pieces was selected to provide equivalent surface area or equivalent insulation mass. A different scheme was used to test the 500 MCM and larger cables. In this case the insulation was removed, flattened, and cut into a 3 inch square.

Prior to actual testing, all samples were conditioned at 50% relative humidity and 70°F for a minimum of 24 hours.

The standard NBS test for wire uses a 3 in. x 3 in. comb around which 10 feet of AWG 20 is wrapped as shown in Figure 5-2. All of the small wire sizes, which were the wires cut to continuous length as described earlier, were wound around the comb in this manner. The larger sizes, cut into three inch lengths, were mounted in the specimen holder as shown in Figure 5-3. The 3 inch squares of insulation removed from 500 MCM and larger cable were flattened and mounted in the specimen holder similar to a fabric specimen. However, in order to maintain the flattened condition of the specimen, a stainless steel wire mesh was utilized. An example of this can be seen in Figure 5-4. In all cases where a 20 AWG sample was provided, other sizes of the same insulation, provided by the same manufacturer, were tested in relation to the 20 AWG sample. When 20 AWG samples were not provided by a manufacturer, the smaller wires were wound on the comb. When the physical size allowed, the length of the sample was 10 feet. If 10 feet of a particular size could not physically fit the comb, the length was changed to 5 feet. When larger sizes were involved and no 20 AWG was provided for a baseline, the number of 3 inch pieces used was the number required to fill the holder.

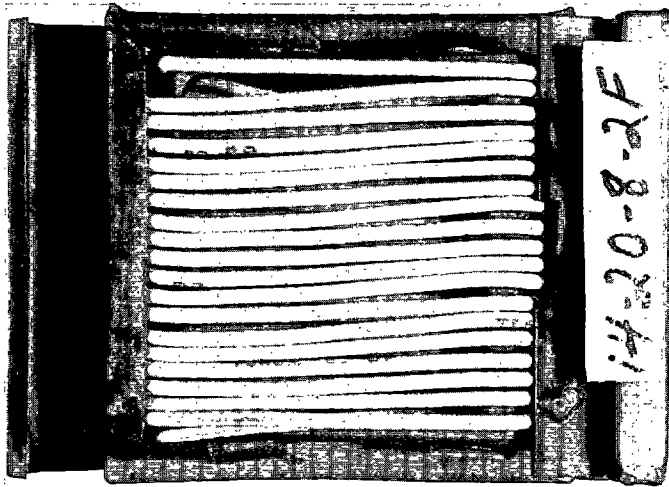

FIGURE 5-2. TEN FEET OF AWG 20 MOUNTED

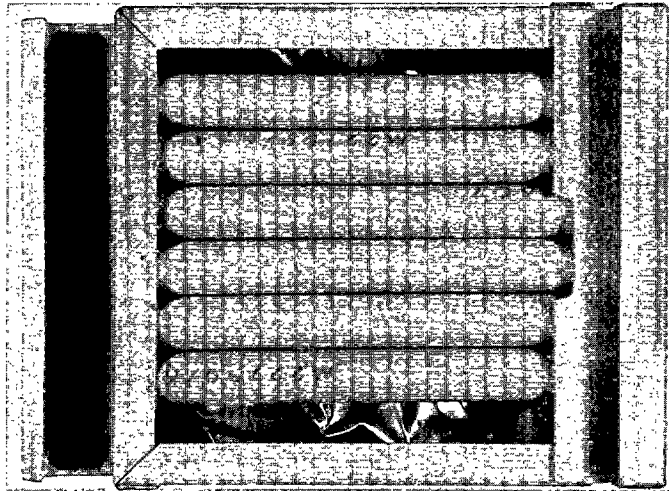

FIGURE 5-3. THREE INCH LENGTHS OF LARGER GAUGE WIRE MOUNTED

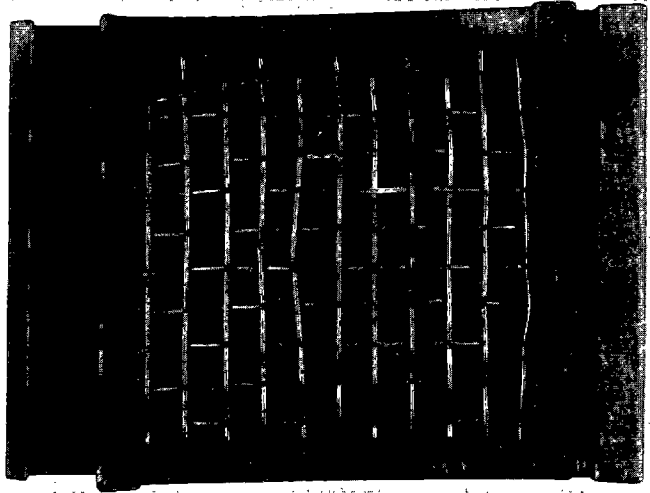

FIGURE 5-4. STEEL MESH TO HOLD INSULATION FROM LARGE GAUGE WIRE IN PLACE

All of the samples were exposed to heat under flaming conditions. The heat source was an electric furnace, adjusted by means of a circular foil radiometer to give a heat flux of 2.5 watts per square centimeter (2.2 BTU per second per square foot) at the specimen surface. Flame was induced by the application of a natural gas diffusion flame applied at the base of the specimen. Duration of test was 20 minutes for each sample. All tests were run in triplicate.

Percent light transmission was plotted on a continuous chart recorder. The data were then transcribed into a computer where the average of three samples was computed. Computer-generated printouts of specific optical density (average), maximum specific optical density, maximum observation index, and computer-generated curves of specific optical density versus time were provided.

One work sheet was prepared for each wire size from each supplier. Each sheet specifies the length of the sample, the method of mounting, either wound on the comb, stacked in the holder, or removed from the conductor and flattened in the holder, and details concerning equivalent surface area and equivalent mass test specimens. Figure 5-5 is typical of the sheets prepared during the test.

5.5 Circuit Integrity Tests

Circuit integrity tests were performed using the same burners and precautions described in Section 5.3. The tests were performed on all single conductor wire AWG 8 and smaller and on all multiconductor cable. Single conductor samples were tested in accordance with the test method described in Section 4.4.5.1, while all of the multiconductor cables were subjected to the test using the Fisher burner described in Section 4.4.5.2. Single conductor wires larger than AWG 8 were not included because of their rigidity and because they were difficult to adapt to the general test procedure in the same manner as the smaller wires.

The results are purely time measurements to failure. Many of the individual wire and cable samples failed in surprisingly equal amounts of time, some of them being very short.

WORK SHEET

WIRE: 11-6-2
WHITE POLYOLEFIN

$$LA = \frac{36.983}{TP(0.287)} = 41.02" = 13.67 \text{ PIECES}$$

$$3" \div 0.287 = 10.45 \text{ (APPROX 11) PIECES}$$

STACK 3 GROUPS OF 11 PIECES EACH IN HOLDERS

NUMBER 11-6-2-1
11-6-2-2
11-6-2-3

CONDITION

TEST 20 MINUTES IN FLAMING MODE + TOXICITY.

$$M_I = 0.98 \text{ g}$$

$$L_M = \frac{20.184}{0.98} = 20.59"$$

$$\frac{20.59}{3} = 7 \text{ PIECES}$$

STACK 3 GROUPS OF 7 PIECES EACH IN HOLDERS

NUMBER 11-6-2-4
11-6-2-5
11-6-2-6

CONDITION

TEST 20 MINUTES IN FLAMING MODE + TOXICITY.

FIGURE 5-5. CALCULATIONS FOR EQUIVALENT SURFACE AREA AND INSULATION MASS WORK SHEET

5.6 Additional Wire and Cable Evaluation Tests

One of the objectives of the program was to attempt to assess the overall performance of the candidate wires and cables in the rapid transit system environment in order to give better overall visibility to system designers. Therefore, it is important that characteristics of the wire other than those associated with a fire environment be available. The tests undertaken below are considered the minimum necessary to accomplish such a task and give data which are not normally available in suppliers catalogs and data sheets.

5.6.1 Scrape Abrasion Resistance Test

All single conductor wires AWG 4 and smaller were subjected to this test. Wires larger than AWG 4 could not be tested on the contractor's laboratory equipment. The test procedure is described below.

APPARATUS

The scrape abrasion tester shall consist of a device which abrades the surface of the wire insulation by means of a weighted scraping fixture. The scraping action shall be in both directions along the longitudinal axis of the wire for a distance of not less than 2 inches (5.1 cm) and at a speed of 30 to 60 cycles (stroke each direction) per minute. The scraping device that contacts the wire surface shall be a tungsten carbide blade as shown in Figure 5-6. During the scraping action, the

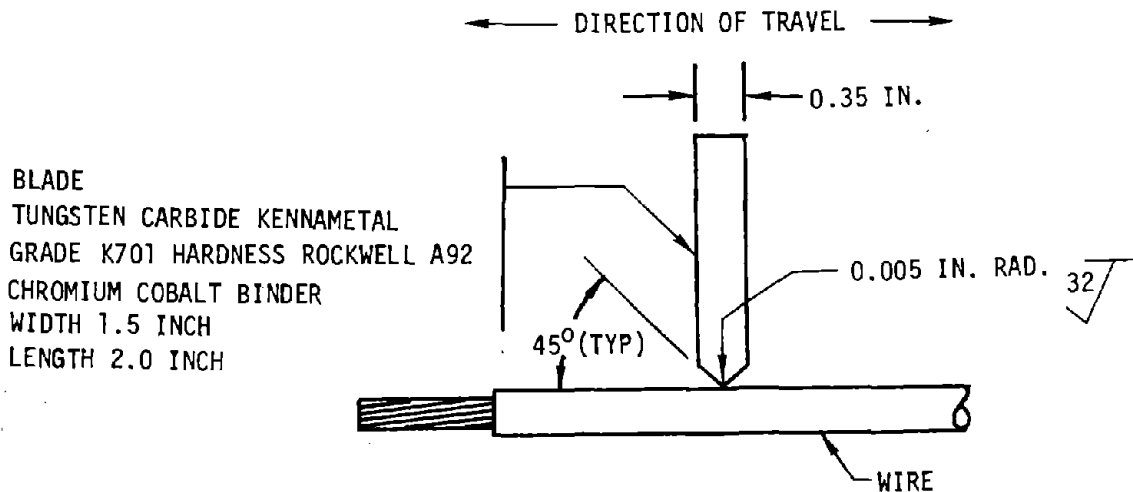

FIGURE 5-6. SCRAPE ABRASION BLADE DETAILS

vertical axis of the blade shall be maintained at 90 ± 2 degrees to the centerline of the test specimen. The test specimen shall be held taut and straight by clamps on a flat supporting anvil. The device shall be equipped with an electrical circuit designed so that when the scraping blade abrades through the wire insulation and contacts the wire conductor, the machine will stop.

PROCEDURE

One inch of insulation shall be removed from one end of a 24 inch specimen of the finished wire. The test specimen shall be clamped in the tester and subjected to the abrasion test. Four tests shall be performed with the specimen moved forward four inches (10.16 cm) and rotated 90 degrees between each test. Scrape abrasion resistance shall be the number of strokes required for the scraping blade to abrade through the wire insulation and stop the machine. The total weight of the tester head and the scraper blade shall be as shown in Table 5-9.

TABLE 5-9 WIRE SIZE VERSUS ABRASION TESTER HEAD

WIRE SIZE	WEIGHT (LB)
20-14	3
12-10	4
6	6
4-1/0	10
2/0	12
Larger	15

5.6.2 Insulation Resistance Test

The insulation resistance was measured on all single conductor wires 500 MCM and smaller, with the exception of the samples submitted by APTA members which were 500 MCM and larger and a few small wires. The reason for omitting these wires was due to insufficient material. The test procedure is described below.

PROCEDURE

The uninsulated ends of a wire specimen at least 26 feet (7.92 m) in length (large wires may require varying lengths depending on their rigidity, minimum bend radius, water bath container dimensions, and other considerations) shall be connected to a positive dc terminal, and the specimen shall be immersed to within 6 inches (15.2 cm) of its ends in a water bath, at $25 \pm 5^{\circ}\text{C}$ ($77 \pm 9^{\circ}\text{F}$), containing 0.5 to 1.0 percent of an anionic wetting agent. The specimen shall remain immersed for not less than four hours, after which a potential of not less than 250 volts nor more than 500 volts shall be applied between the conductor and the water bath, which serves as the second electrode. The insulation resistance shall be determined after one minute of electrification at this potential and shall be expressed as megohms for 1000 feet by the following calculation:

$$\text{megohms for 1000 feet} = \frac{\text{Specimen resistance (megohms)} \times \text{immersed length (feet)}}{1000}$$

5.6.3 Surface Resistance Test

The surface resistance test was performed on all single conductor samples submitted. The test procedure is described below.

PREPARATION OF SPECIMENS

The specimens shall consist of 6-inch lengths of finished wire, cleaned in accordance with the procedure for Group I materials in ASTM D-1371-68. The specimens shall subsequently be handled with maximum care, preferably with clean gloves, to avoid even the slightest contamination, including direct contact with the fingers. Each cleaned specimen shall be provided, near its center, with two electrodes spaced 1.0 ± 0.05 inch apart between their nearest edges. Each electrode shall be approximately 1/2 inch wide and shall consist of conductive silver paint (DuPont 4817 or equivalent) painted around the circumference of the specimen. Electrical connection to the dry electrodes may be made by wrapping several turns of fine (AWG size 28 or finer) tin-coated copper wire around the electrode, leaving a free end of the fine wire or sufficient length for soldering to the electrical lead wires inside the test chamber.

TEST CHAMBER

The test chamber shall be a Blue M Co., Model FR-1000A or equivalent. Ambient conditions for this test shall be a relative humidity of 95 ± 5 percent and a temperature of $23 \pm 3^{\circ}\text{C}$ ($73 \pm 5^{\circ}\text{F}$). The test chamber shown in Figure 5-7 is a tightly covered rectangular glass vessel containing a reservoir of aqueous solution to maintain the required relative humidity (see E104-51 ASTM E 104) and a humidity guage, when applicable, observable from outside the chamber, to indicate the relative humidity actually obtained. On the two long sides of the vessel, tin-coated AWG size 18 solid copper lead wires penetrate and are permanently sealed into a paraffin wax collar at intervals of approximately 1 inch and at least 1 inch from any edge. As an alternative, the leads may be insulated with polytetrafluorethylene (PTFE) and brought outside of the chamber through paraffin wax, silicone stopcock grease, or TFE bushings, provided at least 2 inches of PTFE insulation extend beyond the grease to minimize interchange of air. The electrical resistance of the chamber, measured across the lead wires under the specified test conditions of relative humidity and temperature but with no specimens in place, shall be a minimum of one million megohms.

PROCEDURE

With the specimens and electrodes prepared as specified above, the electrodes shall be connected to the lead wires in the test chamber. In all cases, the wire specimens shall be installed so that their ends are a minimum of one inch from the walls of the chamber. The cover of the chamber shall be put in place, and the test assemblies shall be conditioned for 96 hours at the relative humidity and temperature specified above. The resistance between the electrodes shall then be measured using a dc voltage of 200 to 500 volts, while the specimens are still within the test chamber after a 1 minute electrification. The surface resistance shall be computed by multiplying the measured resistance value by the measured overall diameter of the specimen in inches. Following the initial resistance measurements, a 2500 volt rms 60 Hz voltage shall be applied between electrodes for a period of 1 minute. There shall be no evidence of distress such as arcing, smoking or burning, flashover, or dielectric failure. After a discharge interval of 15 to 20 minutes following the voltage test, the surface resistance shall be remeasured and computed. Both values of computed surface resistance shall be greater than 5 megohms.

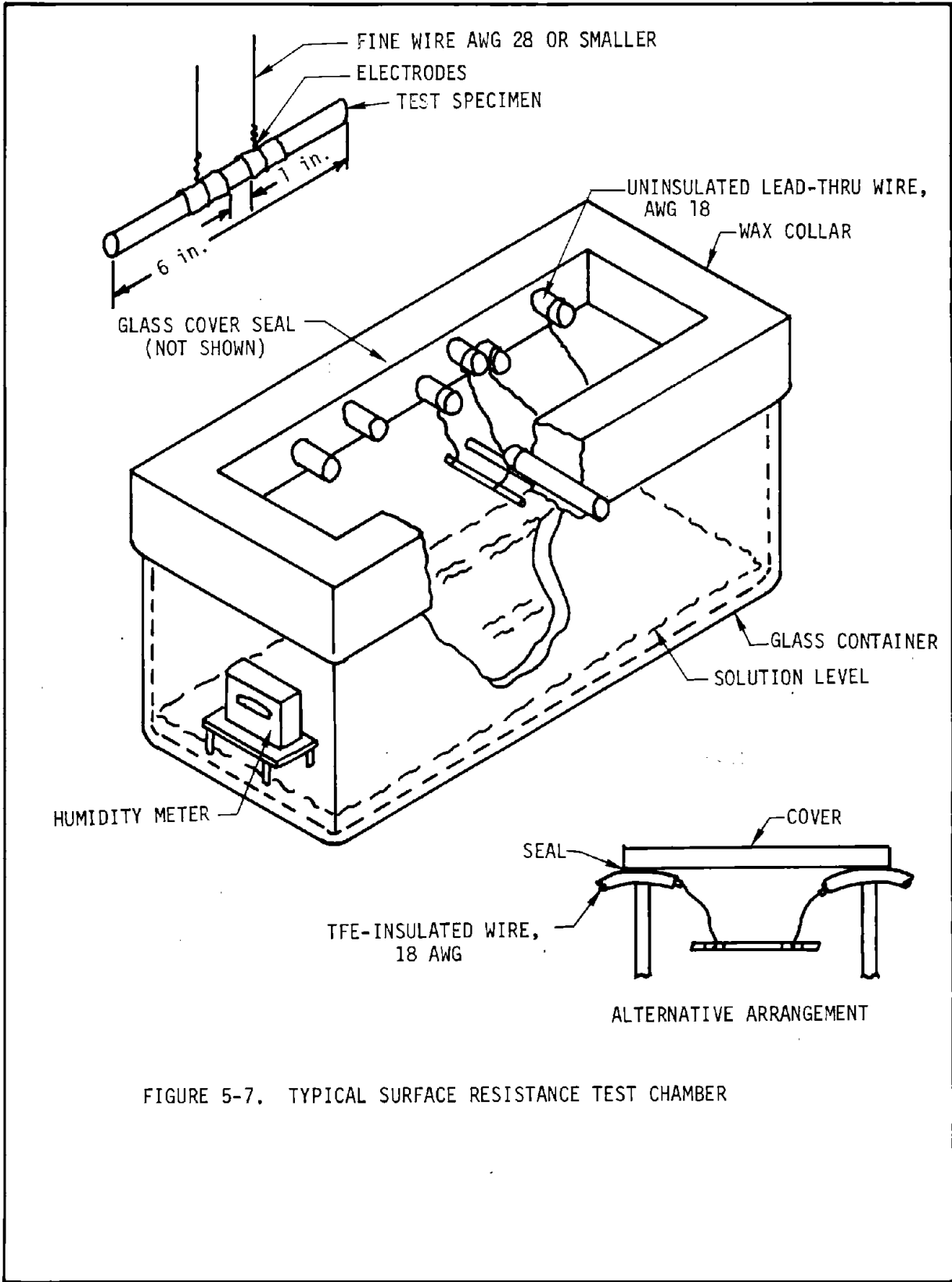

FIGURE 5-7. TYPICAL SURFACE RESISTANCE TEST CHAMBER

5.6.4 Fluid Immersion Test

Nineteen samples were selected with the object of getting as many different materials subjected to the nine fluids selected by the APTA Advisory Board. The number of samples was kept to a minimum due to the large amount of time required to perform each test. The test procedure is described below.

PROCEDURE

Separate specimens of wire of sufficient lengths to perform the subsequent tests shall be immersed to within six inches of their ends in each of the following fluids for 20 hours at room temperature:

- a. Diesel Fuel No. 2
- b. Lubrication Oil, SAE 10
- c. Gasoline
- d. Ethylene Glycol
- e. Isopropyl Alcohol
- f. Trichloroethylene
- g. Sea Water (5% NaCl + 0.5% CaCl₂)
- h. Sewage (1% ammonia solution)
- i. Alkaline Cleaner, DuBois Co., C-1102 (1 to 5 parts water)

During the immersion tests, the radius of bend of the wire shall be not less than fourteen times the maximum diameter of the wire. Upon removal from the liquids, the specimen shall remain for one (1) hour in free air at room temperature. The diameter shall be gauged accurately and compared to the initial diameter. The specimen then shall be subjected to the bend test followed by the dielectric test. The bend test shall be performed at room temperature (68 to 75°F) as follows:

One end of the specimen shall be secured to the mandrel and the other end to a load weight. The mandrel diameter and load weight are listed in Table 5-10. The mandrel shall be rotated until the full length of the specimen is wrapped around the mandrel and is under the tension of the indicated weight with adjoining coils in contact. The mandrel shall then be rotated in reverse direction until the full length of the wire which was outside during the first wrapping is now next to the mandrel. This

procedure shall be repeated until two (2) bends in each direction have been made in the wire. The outer surface of the wire shall then be observed with 10X magnification for cracking of the insulation.

TABLE 5-10 WIRE SIZE VERSUS MANDREL DIAMETER AND LOAD WEIGHT

WIRE SIZE (AWG)	MANDREL DIAMETER (INCHES)	LOAD WEIGHT (POUNDS)
16	1.5	1
12 - 14	3	2
8	5	3
4	8	5
2/0	11	10

The dielectric test is described in the next section.

5.6.5 Dielectric Tests

Dielectric tests were performed on all single conductor samples except those 500 MCM and larger that were furnished by APTA members and a few other samples that were furnished in insufficient quantity. The test procedure for both the dielectric withstand test and the dielectric breakdown test is described below.

DIELECTRIC WITHSTAND TEST

The uninsulated ends of the conductor shall be connected and the specimen shall be immersed in a five percent solution of sodium chloride in water at a temperature of $23 \pm 3^{\circ}\text{C}$ ($73 \pm 5^{\circ}\text{F}$) so that only the insulation at the stripped ends protrudes six inches from the surface of the solution. After immersion for one hour, 3000 volts, 60 Hz shall be applied between the conductor and an electrode in contact with the solution. This voltage shall be gradually increased at a uniform rate from zero to the specified voltage in 1/2 minute, maintained at the voltage for 1 minute, and gradually reduced to zero in 1/2 minute.

DIELECTRIC BREAKDOWN TEST

This test shall be performed in the same manner as the dielectric withstand test except the voltage shall be increased at the rate of 500 volts per second until breakdown.

5.6.6 Dynamic Cut-Through Test

All single conductor samples submitted were subjected to the dynamic cut-through test. Two samples, one with armor and the other with a lead sheath, were tested without the armor and sheath. The test procedure is described below.

TESTING APPARATUS

The dynamic cut-through test shall be performed using a tensile tester operating in a compression mode. The tester shall be equipped with a chart recorder which shall be suitable for recording the force necessary to force a tungsten carbide edge (Figure 5-6) through the insulation of a finished wire specimen. The tester shall also be equipped with a chamber, which will allow the test to be performed at elevated temperatures, and a 12-volt detection circuit designed to stop the tester when the tungsten carbide edge cuts through the wire insulation and contacts the conductor.

TESTING PROCEDURE

One inch of insulation shall be removed from one end of the finished wire specimen. The cutting edge shall be moved through the insulation at a constant rate of 0.5 inch per minute until contact with the conductor occurs. Four tests shall be performed on each specimen and the specimen moved forward one inch, minimum, and rotated clockwise 90 degrees between each test. The cut-through shall be the average of the four tests.

5.6.7 Cold Bend Test

The cold bend test was conducted on all samples in which there was sufficient quantity except the 2000 MCM sample (A3-2000-3), the slotted coax (A7-Coax-3) and the lead sheathed cable (A5-500-2). The first sample mentioned was too large for the cold chamber and the other two were not tested due to their physical nature. The test procedure is described below.

COLD BEND TEST

The test specimen shall be subjected to a temperature of -10°C (-14°F) for not less than two hours, and then immediately bent 180 degrees around a cylindrical mandrel. It shall then be straightened and bent 180 degrees around the mandrel in the opposite direction. The specimen shall be so held during the bending operations that it cannot revolve around its own axis. The diameter of the mandrel shall be determined as shown in Table 5-11.

TABLE 5-11 WIRE DIAMETER VERSUS MANDREL DIAMETER

THICKNESS OF CONDUCTOR INSULATION (INCHES)	MANDREL DIAMETER AS A MULTIPLE OF OUTSIDE DIAMETER OF THE CABLE.	
	≤ 500 MCM	> 500 MCM
Up to 0.1875	8	10
0.203 to 0.3125	10	12
0.328 and thicker	12	12

Following the bend test, the insulation on the specimen shall be observed with 10X magnification for cracks.

6.0 TEST RESULTS AND ANALYSIS

6.1 Flammability Test Results

The results of the flammability testing of each wire sample were recorded on the data sheet shown in Figure 4-2. Figure 6-1 is a typical example of a completed data sheet.

It should be noted that in the tables which will be used as part of the ensuing discussion, wires and cables are categorized by the primary insulation material. This may lead to some confusion when reviewing the charts because in one case a material is shown to have contributed to propagation of fire and in the next line the same material did not contribute to propagation. The reason for the difference is in the construction and in most cases the difference is caused by ancillary materials used as jackets, braids, etc. In most cases an attempt will be made to discuss the influence of jackets and braids even though the overall objective is to rank the wire and cable performance using the insulating material as the basis for comparison. It should be emphasized that all materials with the same generic name may not behave in the same way in a flame environment.

In evaluating the insulating materials submitted for testing, many variables enter into the analysis, making comparison difficult. For example, the size of wire, insulation thickness, method of construction, and compounds are all significant factors. It is difficult to average the results from samples of different wire size or different compounds and formulations of the same general insulating materials to compare with average results of other materials, e.g., silicone rubber compared with polyolefin. However, since this is the only method for comparing the wide variety of materials and sizes tested under this contract, data are lumped together to obtain the general performance for an insulation material. Some samples are constructed with materials other than the primary insulation, and these added or subtracted from the performance in some respects.

The test data show that the ignition time is consistently less for the horizontal tests than the vertical tests. This is probably due to the angle of attack of the flame upon the test specimen.

VERTICAL FLAMMABILITY TEST DATA SHEET							Sheet No. XXXXXXXXXX
Material Description TEPEL (ETFE)						Wire Size 8 AWG MCM	
Manufacturer/Supplier XXXXXXXXXX						Burner Type <input checked="" type="checkbox"/> Bunsen <input type="checkbox"/> Fisher	
Gas Pressure 6.0 In. H ₂ O			Differential Pressure 0.5 In. H ₂ O			Flame Temp. 1750 °F	
Test Date 3/9/77				Tested By DJ/LM			
Specimen No.	1	2	3	4	5	6	Average
Duration of first flame application, seconds.	30	30	30	30	30	30	
Time to ignition, seconds.	5	5	5	5	5	5	5
Flaming after flame removal, seconds.	1	0-1	0-1	0-1	0-1	0-1	0-1
Glowing embers after flame removal, seconds.	0	0	0	0	0	0	0
Duration of second flame application, seconds.	30	30	30	30	30	30	
Total time between flame applications, seconds.	15	15	15	15	15	15	
Flaming after flame removal, seconds.	1-2	1-2	2	2	3	2	2
Glowing embers after flame removal, seconds.	0	0	0	0	0	0	0
Did:							
Specimen drip?	Yes	<input checked="" type="checkbox"/>	<input checked="" type="checkbox"/>	<input checked="" type="checkbox"/>	<input checked="" type="checkbox"/>	<input checked="" type="checkbox"/>	<input checked="" type="checkbox"/>
	No						
Burning particles fall?	Yes						
	No	<input checked="" type="checkbox"/>	<input checked="" type="checkbox"/>	<input checked="" type="checkbox"/>	<input checked="" type="checkbox"/>	<input checked="" type="checkbox"/>	<input checked="" type="checkbox"/>
Specimen convey flame to cotton pad?	Yes						
	No	<input checked="" type="checkbox"/>	<input checked="" type="checkbox"/>	<input checked="" type="checkbox"/>	<input checked="" type="checkbox"/>	<input checked="" type="checkbox"/>	<input checked="" type="checkbox"/>
Specimen convey flame to flame indicator?	Yes						
	No	<input checked="" type="checkbox"/>	<input checked="" type="checkbox"/>	<input checked="" type="checkbox"/>	<input checked="" type="checkbox"/>	<input checked="" type="checkbox"/>	<input checked="" type="checkbox"/>
Burn area:							
Distance from mark, Inches.	Above	5.3	5.5	6.5	6.0	5.9	6.2
	Below	1.2	1.3	1.2	1.2	1.2	1.1
	Total	6.5	6.8	7.7	7.2	7.1	7.3
Smoke: NOTE: SMOKE WAS OBSERVED AFTER FLAME WAS REMOVED (LT. GRAY/WHITE)							
DURING TEST							
<input type="checkbox"/> Heavy <input type="checkbox"/> Moderate/Heavy <input type="checkbox"/> Moderate <input type="checkbox"/> Light/Moderate <input type="checkbox"/> Light <input checked="" type="checkbox"/> None observed							
<input type="checkbox"/> Black <input type="checkbox"/> Black/Gray <input type="checkbox"/> Gray <input type="checkbox"/> Gray/White <input type="checkbox"/> White							
Comments:							
THE INSULATION MATERIAL BURNED READILY WHILE THE FLAME WAS APPLIED BUT EXTINGUISHED ALMOST IMMEDIATELY UPON REMOVAL OF THE FLAME. THERE WERE SOME BARE SPOTS (EXPOSED WIRE) WHERE THE MATERIAL BURNED AND/OR MELTED AND RUN DOWN THE SPECIMEN LEAVING THE EXPOSED COPPER. AS THE SPECIMENS COOL MATERIAL CRACKS, LEAVING EXPOSED COPPER CONDUCTOR.							

FIGURE 6-1. VERTICAL FLAMMABILITY TEST DATA SHEET (COMPLETED)

Flammability test results of all 83 single conductor wires and 19 multiconductor wires are summarized in Tables 6-1 and 6-2. The data contained in Table 6-1 are for single conductor wire and are categorized according to the primary insulation. Thirteen insulation groups are shown. Flame exposure times for both horizontal and vertical tests are also included. Test results for the individual multiconductor samples are shown in Table 6-2.

Data for the AWG 4 and smaller single conductor wires are shown as maximum, minimum, and average by insulation groups in Table 6-3. Wires larger than AWG 4 were not further analyzed, because there were not enough samples of each wire size.

In an attempt to rank the individual materials, each performance parameter was assigned a quantitative value that could be added to indicate a degree of quality of performance. An explanation of the factors used and their derivation follows. The flammability performance factors are summarized in Table 6-4.

Flammability -

- 1) Vertical ignition - An arbitrary observation was a change of flame color and/or addition to the gas flame. On this basis the majority of ignition times are less than 10 seconds. Therefore, any time equal to or greater than 10 seconds was assigned a factor of zero, indicating a good performance. For a projected zero time (not probable), a factor of 2.0 was assigned. All times between zero and 10 seconds were assigned proportionate factor values.
- 2) Horizontal ignition - The same approach was used as in (1) above except that times equal to or greater than 5 seconds were assigned a factor of zero.
- 3) Afterflame/glow - The values of 50 and 100 seconds were chosen to be given a factor of 2.0 for ≤ 4 AWG and >4 AWG wire, respectively. Zero afterflame/glow time was assigned a factor of zero. Samples whose performance exceeded the maximums received no additional penalty.

TABLE 6-1. FLAMMABILITY TEST RESULTS CATEGORIZED BY INSULATION MATERIAL—SINGLE CONDUCTOR (Sheet 1)

SAMPLE NUMBER	TEST TIME (SECONDS) IIF VF	IGNITION (SEC)		AFTER FLAME/GLOW(SEC)		FLAME DAMAGE(IN)		CONVEY FLAME		POST FLAME DIELECTRIC (KV)	REMARKS
		VERTICAL	HORIZONTAL	VERTICAL	HORIZONTAL	VERTICAL	HORIZONTAL	VERT.	HORIZ.		
2-14-1	Asbestos 30- 15/15/15	12	2.5	0	0.5	4.07	1.55	No	No	2266	Little Damage Asbestos/Teflon
		9.4	1.5	0	0	4.72	1.48	No	No	950	
12-12-4	Halar 20- 15/15/15	3	2	0	0	8.0	1.70	No	No	150	Burns readily
		5.2	2.75	130	141	8.65	2.88	No	No	10,400	
15-00-1	Hypalon 180-120/15/120	6	1	0.5	0.5	5.19	1.87	No	No	3316	Little damage
		3	2	52	5.3	11.8	1.75	Yes	No	NA	
2-14-2	Thermoplastic 15- 15/15/15	3	2	14.5	6.1	8.55	1.70	No	No	8300	Ins. Consumed Exposed Cu
		1.5	1	14	30	10.8	4.05	No	No	17,000	
3-20-2	Kapton 10- 10/15/10	4	1	0.5	0	4.53	1.70	No	No	< 100	VF- Some Exp. Cu
		4.2	1	1	0	5.67	1.56	No	No	< 200	
10-20-2	10- 10/15/10	4.4	0.5	0.9	0	6.3	1.46	No	No	980	Nomex Braid Jacket Tape Composite
		3.2	1	0	0	6.6	1.65	No	No	5750	
13-16-1	10- 10/15/10	8	0.5	0	0	6.87	1.48	No	No	1533	Nomex Braid Jacket Tape Composite
		6.3	1	0	0	5.35	1.55	No	No	480	
10-14-2	15- 15/15/15	15	5.3	0	0	4.00	1.42	No	No	6000	Nomex Braid Jacket Tape Composite
		18	3.3	0	0	6.45	1.85	No	No	12300	
13-8-1	300- 60/15/60	10.5	4	0	0	5.5	2.09	No	No	17800	Nomex Braid Jacket Tape Composite
		10	6	0	0	6.1	2.24	No	No	4849	

① Exposed to Fisher burner - others exposed to Bunsen burner. ② Probably PVC ③ Listings such as "30 - 10/15/10" are interpreted as follows: 30 represents the horizontal flame exposure time, 10/15/10 represents the ten second vertical flame exposures separated by a 15 second no-flame condition. NA: Not attempted

TABLE 6-1. CONTINUED

SAMPLE NUMBER	TEST TIME (SECONDS) IIF VF	IGNITION (SEC)		AFTER FLAME/GLOW(SEC)		FLAME DAMAGE(IN)		CONVEY FLAME		POST FLAME DIELECTRIC (KV)	REMARKS
		VERTICAL	HORIZONTAL	VERTICAL	HORIZONTAL	VERT.	HORIZ.				
14-20-5	polyethylene	5	2.3	300	180	30	14.5	Yes	No	NA	Completely Consumed
A7-2-1	10- 10/- / -	10	4.5	③	3	①③	①2.56	Yes	No	8000	
A5-00-3	120- 60/15/60	14	11	780	600	①7.3	①4.6	No	No	NA	Glow for a long time
9-20-1	Polyester	1.7	1	2	0.6	7.5	2.56	No	No	NA	Ins. Consumed
9-16-1	10- 10/15/10	1.2	1	4.7	1	7.3	2.51	No	No	NA	
6-20-1	Polyolefin	2.75	1.2	1	0.5	5.00	2.11	No	No	6000+	
11-20-1	10- 10/15/10	2	1	28	12	4.85	1.75	No	No	600	
6-16-1	15- 15/15/15	3	1	31	0	5.45	2.04	No	No	6000	
11-16-1	15- 15/15/15	2.5	1.5	86	11	5.83	1.74	No	No	1800	
6-8-1	60- 30/15/30	4.5	2	85	103	5.88	2.56	No	No	2333	
11-8-2	60- 30/15/30	3	2.4	112	38	6.23	2.10	No	No	1700	
11-6-2	60- 45/15/45	4.5	2.2	66	26	6.77	2.24	No	No	900	
6-4-1	120- 60/15/60	5	3	88	88	6.58	2.68	No	No	1442	
6-00-1	120- 90/15/90	6.4	4.7	194	221	①8.33	①3.58	No	No	2580	Some Exp. Cu
11-00-1	120-120/15/120	7	3	149	86	①8.35	①2.88	No	No	4650	
11-500-1	240-180/15/180	6.2	4.9	555	282	①10.96	①5.43	No	No	3490	
14-20-1	Polyvinyl Chloride	1	0.5	6	4	10.0	2.07	No	No	400	Some Exp. Cu
14-20-2	10- 10/15/10	1	0.7	5.5	5	10.45	2.12	No	No	425	Some Exp. Cu
14-20-3	10- 10/15/10	1.5	1	4.1	3	9.78	1.85	No	No	<500	
14-20-4	10- 10/15/10	1.4	0.6	0	0	9.80	1.79	No	No	2600	

① Exposed to Fisher Burner - others exposed to Bunsen Burner ② Without Armor ③ NA: Not attempted
 ④ All specimens burned 3 Min. Two were required to be extinguished. ④ See note 3, sheet 1

TABLE 6-1. CONTINUED

SAMPLE NUMBER	TEST TIME (SECONDS) IF VF	IGNITION (SEC)		AFTER FLAME/GLOW(SEC)		FLAME DAMAGE (IN)		CONVEY FLAME		POST FLAME DIELECTRIC (KV)	REMARKS
		VERTICAL	HORIZONTAL	VERTICAL	HORIZONTAL	VERTICAL	HORIZONTAL	VERT.	HORIZ.		
Polyvinyl Chloride (Cont.)											
14-20-6	10- 10/15/10	2.6	1.4	2.6	2.8	7.80	1.66	No	No	2250	
4-16-1	15- 15/15/15	2	1	77	13.2	6.10	1.91	No	No	1200	
A1-14-1	15- 15/15/15	2	1	3.8	1	8.35	1.72	No	No	225	Some Exp. Cu
4-8-1	45- 30/15/30	3.5	2.5	2.5	1.3	6.35	2.14	No	No	1575	
4-500-1	240-240/15/240	5.1	4.6	0	0	9.21	3.65	No	No	4180	
A4-1000-3	240-120/15/120	4	3	28	34	11.7	5.8	No	No	24300	VF-Some Exp. Cu
Rubber, Etc.											
A5-14-1	30- 15/15/15 (EPR/Hypalon)	4	2.45	1	30	5.47	2.15	No	No	32400	
A5-14-2	30- 15/15/15 (EPR)	4	2	35	16	5.87	2.06	No	No	27700	Thick Insul.
A5-000-4	240-180/15/180 (Butyl Rub/Neoprene)	8	3.75	120	187	9.6	4.00	No	No	13900	
A4-500-1	600-300/15/300 (Rubber/PVC)	4.25	3	18	11	11.95	2.6	No	No	> 50kv	
A7-00-2	300-120/15/120 (EPR/Neoprene)	6	3.5	0	2	8.43	3.47	No	No	31 to 36kv	
A4-500-2	600-540/15/540 (Rubber/Lead)	238	40	55	34	7.7	2.6	No	No	NA	
A3-2000-3	1200-600/15/600 (EPR/Neoprene)	11.3	11	97	92	10.0	8.6	No	No	7.5 to 21.8kv mismatch	Burner/wire mismatch
Silicone Rubber											
1-20-1	15- 10/15/10	2	1	32	11	5.08	1.65	Yes	No	6000	Polyolefin Jkt.
9-20-2	10- 10/15/10	3.5	2	13	8.2	5.08	1.85	No	No	5535	Perylene compl. consumed
14-20-8	10- 10/15/15	1.8	1	4	8.5	10.53	1.96	Yes	No	4415	
1-16-1	30- 15/15/15	2.7	1.3	34	10	5.58	1.89	Yes	No	6000	Polyolefin Jkt.

⊙ Exposed to Fisher burner - others exposed to Bunsen burner.

MA:- Not Attempted.

⊙ See note 3, sheet 1

TABLE 6-1. CONTINUED

SAMPLE NUMBER	TEST TIME (SECONDS) IIF VF	IGNITION (SEC)		AFTER FLAME/GLOW(SEC)		FLAME DAMAGE(IN)		CONVEY FLAME		POST FLAME DIELECTRIC (KV)	REMARKS
		VERTICAL	HORIZONTAL	VERTICAL	HORIZONTAL	VERTICAL	HORIZONTAL	VERT.	HORIZ.		
		(Cont.)									
		Silicone Rubber									
5-16-3	20- 15/15/15	5	2	16	12	5.03	2.03	Yes	No	2600	
9-16-2	15- 15/15/15	6	2	10	8	5.60	1.88	No	No	6000+	
14-16-8	15- 15/15/15	1.5	1	1	11	10.22	2.08	Yes	No	6000	Terylene compl. consumed
14-14-10	15- 15/15/15	5.5	2.8	168	21	8.36	1.80	No	No	8300	
1-8-1	60- 30/15/30	4	2.5	34	11	6.00	2.04	No	Yes	3770	Polyolefin Jkt.
9-8-2	300- 30/15/30	10	4.0	13	0	5.92	2.34	Yes	No	6000	
1-4-1	300-300/15/300	5	3.1	0	0	8.3	2.19	No	Yes	15850	Polyolefin Jkt.
9-4-2	600-180/15/180	5	4.0	0	0	7.35	2.55	Yes	Yes	11230	
		Teflon									
10-20-1	10- 10/15/10	3.5	1.5	0	0	4.23	1.36	No	No	NA	All Cracked
12-20-1	10- 10/15/10	2.7	1.5	0	0	5.62	1.38	No	No	One-1300	other cracked
12-20-2	10- 10/15/10	2.5	1.5	0	0	5.24	1.41	No	No	3- 1900	3 cracked
14-20-7	10- 10/15/10	3	1.7	0	0	5.67	1.41	No	No	NA	Exp. Cu.
10-16-1	15- 15/15/15	3	2	0	0	4.83	1.56	No	No	NA	Cracks
14-16-7	10- 15/15/15	4.6	1.5	0	0	5.38	1.32	No	No	NA	Cracks during Test
10-4-1	90- 90/15/90	8.25	5.5	0	0	5.60	1.94	No	No	NA	Exp. Cu
10-500-4	240-240/15/240	15	12.2	0	0	7.27	3.55	No	No	NA	
		Tefzel									
3-20-1	10- 10/15/10	2.2	0.5	1	0.3	5.3	1.83	No	No	NA	Exp. Cu
5-20-1	10- 10/15/10	3	1	1.7	1.3	3.83	1.9	No	No	NA	Exp. Cu
10-18-3	10- 10/15/10	2.6	1.2	4.4	2.6	5.98	1.57	No	No	475	Some Exp. Cu
8-16-1	15- 15/15/15	2	1.5	3	1.2	6.6	1.79	No	No	100	Some Exp. Cu
10-16-3	15- 15/15/15	3	1.5	3	1.5	5.89	1.85	No	No	NA	Exp. Cu
12-16-3	15- 15/15/15	3.5	2	2.2	2.3	8.73	1.66	No	No	NA	Some Exp. Cu

①

Exposed to Fisher burner - others exposed to Bunsen burner.

NA: - Not Attempted

②

See note 3, sheet 1

TABLE 6-1. CONTINUED

SAMPLE NUMBER	TEST TIME (SECONDS) HF VF	IGNITION (SEC)		AFTER FLAME/GLOW(SEC)		FLAME DAMAGE(IN)		CONVEY FLAME		POST FLAME DIELECTRIC (KV)	REMARKS
		VERTICAL	HORIZONTAL	VERTICAL	HORIZONTAL	VERTICAL	HORIZONTAL	VERT.	HORIZ.		
12-12-3	Tefzel (Cont.) 20- 15/15/15	4.5	2.5	4.8	0	7.93	1.59	No	No	5725	Some Exp. Cu Test Too Severe Exp. Cu Some Exp. Cu
12-10-3	30- 30/15/30	4.7	3	3	0	9.17	1.70	No	No	1317	
3-8-1	60- 30/15/30	6	2	1.5	0	5.95	1.53	No	No	850	
10-8-3	60- 30/15/30	5	3.3	2.0	0	7.1	1.82	No	No	900	
10-3-3	60- 60/15/60	6.7	3.7	2.3	0	①10.42	① 2.89	No	No	NA	
10-00-3	120- 90/15/90	9	6	0	0.3	① 8.70	① 3.40	No	No	NA	

① Exposed to Fisher burner - others exposed to Bunsen burner.

② See note 3, sheet 1

NA: Not attempted

TABLE 6-2. FLAMMABILITY TEST RESULTS - MULTICONDUCTOR CABLE

SAMPLE NUMBER	TEST TIME (SECONDS) HF VF	IGNITION TIME (SEC.)		AFTER FLAME/GLOW (SEC)		FLAME DAMAGE (IN)		CONVEY FLAME		REMARKS
		VERTICAL	HORIZONTAL	VERTICAL	HORIZONTAL	VERTICAL	HORIZONTAL	VERT.	HORIZ.	
2-2x16-1 (2)	45 60/15/60	7.7	4.25	-	17.2	-	2.08	-	No	Some exposed wire.
3-7x20-1 (2)	45 60	-	2.25 2.25	58/36	0	6.27	2.05 2.13	No	No	
3-7x20-2 (2)	45 60	4.9 4.9	-	2.1/0.5 0	-	5.68 6.60	-	No	No	Burned brilliantly, mlt'd. and ran down specimens.
4-7x12-1	180 300 600	-	10.5 10.5	0	0	-	1.62 1.71	-	No	
4-7x12-2	180 300 600	15.1 15.1	-	0	10	6.2 6.4	3.75 3.9 4.1	No	No	Heavy smoke-sparks & flame jets radially Black smoke during flame Burned readily at first
13-7x14-1	180 300 600	7.75 7.75	3.2 3.2 3.2	6/1 0/1	7	9.0 9.55	3.7 3.62 4.15	No	No	
13-7x14-2	180 300	7	5.2 5.2	4/4 6/98 1/37	3.5	7.7 8.8 8.95	-	No	No	Inner Ins. visible - slight damage. Completely destroyed except mica tape wrap Mica tape exposed occasionally Melts, drips & burns readily Burns readily - Mica tape exposed.
13-7x14-2	180	7	5	0	0	-	2.72 3.02	No	No	
	60/15/60 90/15/90	9.25 9.25	-	0/1 0.5/7.7	-	8.63 8.93	-	No	No	

(1) Listings such as "180" and "90/15/90" are interpreted as follows: "180" represents the horizontal flame exposure time, "90/15/90" represents the two vertical flame exposure times separated by a 15 second no-flame condition.
 (2) Exposed to Bunsen burner only.

TABLE 6-2. CONTINUED

SAMPLE NUMBER	TEST TIME (SECONDS) (1) UF VF	IGNITION TIME (SEC.)		AFTER FLAME/GLOW (SEC.)		FLAME DAMAGE (IN)		CONVEY FLAME		REMARKS
		VERTICAL	HORIZONTAL	VERTICAL	HORIZONTAL	VERTICAL	HORIZONTAL	VERT.	HORIZ.	
13-7x12-3	180	-	2.5	-	-	2.20	-	No	No	Only slight damage to primary insulation No individual wire ins. is exposed.
	300	-	2.5	-	-	2.30	-	No	No	
	600	-	2.5	-	-	2.52	-	No	No	
6-7x12-1	120/15/120	40	-	0	6.4	-	-	No	-	Heavy Smoke, burns readily, damage only to Jacket Jacket destroyed-paper tape protects primary Insulation.
	180/15/180	40	-	0	7.0	-	-	No	-	
	180	-	3	-	-	3.98	-	No	No	
12-3x16-1 (2)	300	-	3	-	-	4.18	-	No	No	Burns readily-melts, drips & smokes. Shield exposed 4.2 in.
	600	-	3	-	-	4.20	-	No	No	
	120/15/90	7	-	87/74	8.3	-	-	No	-	
A2-19x12-3	120/15/120	7	-	85/69	8.2	-	-	No	-	Burned readily-Hvy. smoke Fuel consumed by 3 1/2-4 min. Jacket & filmwrap protect primary from major damage.
	30	-	3.5	-	-	2.16	-	No	No	
	45	-	3.5	-	0/2	2.14	-	No	-	
A2-6/2x19-4	45/15/45	5	-	-	7.70	-	-	No	-	Burned readily-Hvy. smoke Fuel consumed by 3 1/2-4 min. Jacket & filmwrap protect primary from major damage.
	120	-	3.8	-	-	4.05	-	No	No	
	240	-	3.8	-	-	4.40	-	No	No	
A3-7x14-1	300	-	3.8	-	-	4.47	-	No	-	Flame increased until all was engulfed. Second application had to be extinguished after 5 minutes.
	180/15/180	7.7	-	0/0.7	11.9	-	-	No	-	
	60	-	6	-	168/-	-	-	-	-	
A3-7x14-2	300	15	-	-	-	3.98	-	No	-	Smokes & smells bad Char 175% orig. dta. Burns readily-showers sparks & burning particles Large burning particles (1"x1/2") fall-50% of jacket flaked away-Not burned through.
	180	8	-	3/0	10.17	-	-	No	-	
	240	-	3.1	-	-	3.62	-	No	No	
A3-7x14-4	300	-	3.1	-	-	3.70	-	No	No	Cable flamed for 45 sec. Black smoke on second flame application.
	180/15/180	6.2	-	151/342	9.63	-	-	No	-	
	120	7.2	3.1	-	0	2.67	-	No	-	

(1) See Note 1, Sheet 1.

(2) Exposed to Bunsen burner only.

TABLE 6-2. CONTINUED

SAMPLE NUMBER	TEST TIME (SECONDS) HF VF	IGNITION TIME (SEC)		AFTER FLAME/GLOW(SEC)		FLAME DAMAGE(IN)		CONVEY FLAME		REMARKS
		VERTICAL	HORIZONTAL	VERTICAL	HORIZONTAL	VERTICAL	HORIZONTAL	VERT.	HORIZ.	
A3-7x14-5	120 90/15/90	7	2.9	- 187/58	105	- 7.68	2.66	- No	No -	Burned readily for 60 sec. Jacket destroyed on flame side-Showered sparks
A5-Mx19-5	180 240	- -	3.5 3.5	- -	6.5 17.5	- -	6.4 6.4	- -	No No	Burns readily-Hot grease drips & squirts from specimens
	60/15/60 90/15/90 120/15/180	4 4 4	- - -	2/0 1/4 5/9	- - -	11.9 11.9 11.9	- - -	No No No	- - -	Jacket burns readily-Hot grease came out of bottom end of specimen.
A6-4x12-1	120 120/15/120	- 9.5	4 -	- 18/25	0	- 8.1	2.48	- No	No -	Weak flame Little apparent damage.
A7-6x19-4	60 30	- -	5.5 5.5	- -	- -	- -	- -	- -	- -	With one 30 sec. flame exposure, the flaming jacket increased in intensity until the flaming specimen had to be extinguished.
	90/-/- 60/-/-	7.5 7.5	- -	- -	- -	- -	- -	- -	- -	Jacket burned readily exposing second layer which melted and dripped. Metallic shield acted as flame barrier.
A7-24x19-5	120 180 390 570	- - - -	3.3 3.3 3.3 3.3	- - - -	10 46 390 393	- - - -	4.6 4.7 5.25 5.7	- - - -	No No Yes Yes	Burned readily with moderate smoke Allowed to burn until significant happening - oil dripped
	60/15/60 90/15/90 120/15/120	4.5 4.5 4.5	- - -	2/3 4/6 39/103	- - -	8.3 8.6 8.4	- - -	No No No	- - -	Heavy smoke-smoked for long time after flame was removed.
A7-Coax-3	120 180 240	- - -	5.3 5.3 5.3	- - -	107 289 527	- - -	5.10 5.22 5.60	- - -	No No No	Jacket burns readily Inner material melts and feeds flame when slots are on bottom or toward flame.
	120/15/120 130/15/120	8.5 8.5	- -	67/200 104/494	- -	10.30 12.85	- -	No No	- -	

①

See Note 1, Sheet 1.

②

Slots away from flame.

③

Slots toward flame.

TABLE 6-3. FLAMMABILITY TEST RESULTS, AVERAGE OF "LUMPED" MATERIALS, WIRES AWG 4 AND SMALLER (Sheet 1)

INSULATION MATERIALS (No. of Samples).	IGNITION TIME(SEC)		AFTER FLAME/GLOW(SEC.)		FLAME DAMAGE (IN)		CONVEY FLAME?		POST FLAME DIELECTRIC (kv)
	VERTICAL	HORIZONTAL	VERTICAL	HORIZONTAL	VERTICAL	HORIZONTAL	VERT.	HORIZ.	
<u>Asbestos</u> (2)	Min.	1.5	0	0	4.07	1.48	No	No	950
	Avg.	2.0	0	0	4.40	1.52	No	No	1600
	Max.	2.5	0	0	4.72	1.55	No	No	2250
<u>Halar</u> (1)	Avg.	2	0	0	8.0	1.70	No	No	150
	Avg.	6	1	0.5	5.19	1.87	No	No	3316
<u>Mica</u> (1)	Min.	1	14	8.55	1.70	No	No	No	Bare Cu
	Avg.	1.5	33	10.2	1.72	No	50/50	No	4150
	Max.	2	52	11.8	1.75	Yes	Yes	No	8300
<u>Thermoplastic</u> (2)	Min.	0.5	0	4.00	1.42	No	No	No	< 100
	Avg.	1.96	0.25	5.7	1.64	No	No	No	5015
	Max.	4	0.9	6.87	2.09	No	No	No	17800
<u>Kapton</u> (9)	Min.	2.3	300	30	14.5	Yes	Yes	No	Bare Cu
	Avg.	5	180	30	14.5	Yes	Yes	No	Bare Cu
<u>Polyethylene</u> (1)	Min.	1	2	7.3	2.51	No	No	No	Bare Cu
	Avg.	1	3.35	7.4	2.53	No	No	No	Bare Cu
	Max.	1	4.7	7.5	2.56	No	No	No	Bare Cu
<u>Polyester</u> (2)	Min.	1	1	4.85	1.74	No	No	No	900
	Avg.	1.79	57.1	5.82	2.15	No	No	No	2597
	Max.	3	112	6.77	2.68	No	No	No	6000+
<u>Polyolefin</u> (8)	Min.	0.5	0	6.10	1.66	No	No	No	225
	Avg.	1.1	12.7	8.56	1.91	No	No	No	1446
	Max.	2.5	77	10.45	2.14	No	No	No	2600
<u>Polyvinyl Chloride</u> (8)	Min.	0.5	0	6.10	1.66	No	No	No	225
	Avg.	1.1	12.7	8.56	1.91	No	No	No	1446
	Max.	2.5	77	10.45	2.14	No	No	No	2600

Exercise caution. All materials of the same generic name do not behave the same in a flame situation.

TABLE 6-3. CONTINUED

INSULATION MATERIAL (No. of Samples)	IGNITION TIME (SEC)		AFTER FLAME/GLOW (SEC)		FLAME DAMAGE (IN)		CONVEY FLAME?		POST FLAME DIELECTRIC (KV)
	VERTICAL	HORIZONTAL	VERTICAL	HORIZONTAL	VERTICAL	HORIZONTAL	VERT.	HORIZ.	
<u>Silicone Rubber</u> (12) Min. Avg. Max.	1.5	1	0	0	5.03	1.65	7 Yes	3 Yes	2600
	4.33	2.31	27.1	8.4	6.92	2.02			6804
	10	4.5	168	21	10.53	2.34	5 No	9 No	15850
<u>Teflon</u> (7) Min. Avg. Max.	2.5	1.5	0	0	4.23	1.32	No	No	Cracks
	3.9	2.2	0	0	5.22	1.48	No	No	
	8	6	0	0	5.67	1.94	No	No	
<u>Tefzel</u> (10) Min. Avg. Max.	2	0.5	1	0	3.83	1.57	No	No	Some Bare
	3.15	1.95	2.66	0.95	6.65	1.72	No	No	
	6	3.3	4.8	2.6	9.17	1.9	No	No	
<u>EPR/Hypalon</u> (1) Avg.	4	2.5	1	30	5.47	2.15	No	No	32,400

Exercise caution. All materials of the same generic name do not behave the same in a flame situation.

- 4) Flame damage - The maximums of 10 and 2.5 inches were chosen to be assigned a factor of 2.0 for vertical and horizontal tests, respectively. No damage (improbable situation) was assigned a factor of zero. Other types of damage were assigned proportional factors. Exposed conductor was grounds for an additional penalty. A 2.0 was assigned if all samples exhibited bare conductor. Proportionately lesser penalties were assessed for fewer samples in violation.
- 5) Conveyance of flame - This is a yes or no situation based upon the condition of the flag or the cotton pad and was given a factor of 1.0 or 0.0, respectively.
- 6) Dielectric strength (after horizontal test) - Some test specimens were required to withstand 6 kV for 60 seconds while others were tested to failure at higher potentials. Voltages of 6 kV or greater were assigned a factor of 0.0. Zero volts were assigned a 1.0 factor. Values within the limits were given proportionate factors. Wires on which the insulation split after it cooled were arbitrarily given a 0.9 to indicate a slight superiority to a bare wire.

TABLE 6-4 SUMMATION OF FLAMMABILITY PERFORMANCE FACTORS

Vertical ignition time	0 to 2
Horizontal ignition time	0 to 2
Vertical afterflame/glow	0 to 2
Horizontal afterflame/glow	0 to 2
Vertical flame damage	0 to 2
Horizontal flame damage	0 to 2
Conveyance of flame	0 to 1
Dielectric strength	0 to 1
Total	0 to 14

Therefore the wires and cables which received the lowest number of points were considered to have the best performance in the flammability test.

These factors were applied to each of the single conductor wire test performance parameters and are shown in Table 6-5 for all wires. A ranking of insulation groups is shown in Table 6-6. Though this appears to be final, it deserves to be emphasized that several of these material/construction samples are represented by only one test sample.

Some samples of wire performed exceptionally well under the flame conditions of the vertical and horizontal tests while others were disappointing. Two samples containing asbestos showed little damage, and the postflame dielectric (PFD) qualities were perhaps lower than expected but acceptable. Only one sample insulated with Halar was submitted for test. This insulation burned readily leaving a black char over all the wire, but extinguished immediately upon removal of the gas flame. The PFD was low. A single sample of Hypalon performed about average, but because of its heavy insulation, it had a good PFD. Though the flame extinguished immediately, there were glowing embers for over two minutes after removal of the flame. One sample of mica-insulated wire performed well.

Three samples of common everyday thermoplastic (probably PVC) insulated wire used for wiring buildings and connecting machines was tested. The nylon jacket on A2-14-2 was credited for improved performance compared to A2-14-1. The insulation on sample A2-250-2 has a wall thickness of approximately 0.1 inch which made for good PFD performance after the 180 sec. flame exposure.

Wires insulated with Kapton (polyimide tape) performed very well in flame conditions. Ignition is one of the weaker points on small wires, but damage and afterflame and/or glow was a minimum. PFD results were low on two wires but probably acceptable on all others.

Sample 14-20-5, insulated with polyethylene, burned from end to end in both the vertical and horizontal tests, leaving only the bare conductor and occasional bits of char. Two other polyethylene-insulated samples also had problems. Sample A7-2-1 burned for 3 or more minutes after the second 60 sec. flame exposure during the vertical test. The PFD was 8,000 volts after 120 sec. flame exposure. A5-00-3 glowed (smoldered and smoked) for over 10 minutes after the flame exposure in both the horizontal and vertical tests. However, this sample did not ignite readily.

TABLE 6-5. FLAMMABILITY EVALUATION — SINGLE CONDUCTOR

SAMPLE NUMBER	INSULATION MATERIAL	IGNITION TIME (SEC)		AFTERFLAME/GLOW (SEC)		FLAME DAMAGE (IN)		CONVEY FLAME? YES OR NO 1.0 OR 0	POST FLAME DIELECTRIC 6kV TO 0 0 TO 1.0	FACTOR SUMMATION 0 to 14
		VERTICAL 0 TO 2.0	HORIZONTAL 0 TO 2.0	VERTICAL 0 TO 2.0	HORIZONTAL 0 TO 2.0	VERTICAL 0 TO 2.0	HORIZONTAL 0 TO 2.0			
AWG 20										
1-20-1	Silicone Rubber	1.600	1.600	1.280	0.440	1.016	1.320	1.000	0.000	8.256
3-20-1	Tefzel/Polyimide	1.560	1.800	0.040	0.012	2.000*	2.000*	0.000	1.000	8.412
3-20-2	Kapton	1.200	1.600	0.020	0.000	0.906	1.360	0.000	0.983	6.069
5-20-1	Tefzel	1.400	1.600	0.068	0.052	2.000*	2.000*	0.000	1.000	8.120
6-20-1	Polyolefin	1.450	1.520	0.040	0.020	1.000	1.688	0.000	0.000	5.718
9-20-1	Polyester	1.660	1.600	0.080	0.024	2.000*	2.000	0.000	1.000	8.364
9-20-2	Silicone Rubber	1.300	1.200	0.520	0.328	1.016	1.480	0.000	0.078	5.922
10-20-1	Teflon (PTFE)	1.300	1.400	0.000	0.000	0.846	1.088	0.000	0.900	5.534
10-20-2	Kapton	1.160	1.600	0.040	0.000	1.134	1.248	0.000	0.967	6.149
11-20-1	Polyolefin	1.600	1.600	1.120	0.480	0.970	1.400	0.000	0.900	8.070
12-20-1	Teflon (EE)	1.460	1.400	0.000	0.000	1.124	1.104	0.000	0.900	5.988
12-20-2	Teflon (TFE)	1.500	1.400	0.000	0.000	1.048	1.128	0.000	0.842	5.918
13-20-1	Kapton/Polyimide	1.120	1.800	0.036	0.000	1.260	1.168	0.000	0.837	6.221
14-20-1	Polyvinyl Chloride	1.800	1.800	0.240	0.160	2.000	1.770*	0.000	0.933	8.703
14-20-2	Polyvinyl Chloride	1.800	1.720	0.220	0.200	2.000	1.848*	0.000	0.922	8.710
14-20-3	Polyvinyl Chloride	1.700	1.600	0.164	0.120	1.956	1.480	0.000	0.922	7.942
14-20-4	Polyvinyl Chloride	1.720	1.760	0.000	0.000	1.960	1.432	0.000	0.567	7.439
14-20-5	Polyethylene	1.000	1.080	2.000	2.000	2.000	2.000	1.000	1.000	12.080
14-20-6	Polyvinyl Chloride	1.480	1.440	0.104	0.112	1.560	1.328	0.000	0.625	6.649
14-20-7	Teflon (PTFE)	1.400	1.320	0.000	0.000	1.134	2.000*	1.000	1.000	7.854
14-20-8	Silicone Rubber	1.640	1.600	0.160	0.340	2.000	1.568	1.000	0.263	8.571
14-20-9	Kapton	1.360	1.600	0.000	0.000	1.320	1.320	0.000	0.042	5.642
AWG 18										
10-18-3	Tefzel	1.480	1.520	0.176	0.104	1.598*	1.502*	0.000	1.000	7.380

* Reflects penalty for exposed conductor.

TABLE 6-5. CONTINUED

SAMPLE NUMBER	INSULATION MATERIAL	IGNITION TIME (SEC)		AFTERFLAME/GLOW (SEC)		FLAME DAMAGE (IN)		CONVEY FLAME ? YES OR NO 1, 0 OR 0	POST FLAME DIELECTRIC 6KV TO 0 0 TO 1.0	FACTOR SUMMATION
		VERTICAL 0 TO 2.0	HORIZONTAL 0 TO 2.0	VERTICAL 0 TO 2.0	HORIZONTAL 0 TO 2.0	VERTICAL 0 TO 2.0	HORIZONTAL 0 TO 2.0			
<u>AWG 16</u>										
1-16-1	Silicone Rubber	1.460	1.480	1.360	0.400	1.116	1.512	1.000	0.000	8.328
4-16-1	Polyvinyl Chloride	1.600	1.600	2.000	0.528	1.220	1.528	0.000	0.800	9.276
5-16-2	Teflon/Asbestos	0.120	1.400	0.000	0.000	0.944	1.184	0.000	0.842	4.490
5-16-3	Silicone Rubber	1.000	1.200	0.640	0.480	1.006	1.624	1.000	0.567	7.517
6-16-1	Polyolefin	1.400	1.600	1.240	0.000	1.090	1.632	0.000	0.000	6.962
8-16-1	Tefzel	1.600	1.400	0.120	0.048	2.000*	1.813*	0.000	1.000	7.981
9-16-1	Polyester	1.760	1.600	0.188	0.040	2.000*	2.000	0.000	1.000	8.588
9-16-2	Silicone Rubber	0.800	1.200	0.400	0.320	1.120	1.504	0.000	0.000	5.344
10-16-1	Teflon (PTFE)	1.400	1.200	0.000	0.000	0.966	1.248	0.000	0.900	5.714
10-16-3	Tefzel	1.400	1.400	0.120	0.060	2.000*	2.000*	0.000	1.000	7.980
11-16-1	Polyolefin	1.500	1.400	2.000	0.440	1.166	1.392	0.000	0.700	8.598
12-16-3	Tefzel	1.300	1.200	0.088	0.092	2.000*	1.886*	0.000	1.000	7.566
13-16-1	Kapton/Polyimide	0.400	1.800	0.000	0.000	1.374	1.184	0.000	0.744	5.502
14-16-7	Teflon (PTFE)	1.080	1.400	0.000	0.000	2.000*	2.000*	0.000	0.900	7.380
14-16-8	Silicone Rubber	1.700	1.600	0.040	0.440	2.000	1.664	1.000	0.000	8.444
<u>AWG 14</u>										
2-14-1	Asbestos	0.000	1.000	0.000	0.020	0.814	1.240	0.000	0.623	3.697
2-14-2	Mica	0.800	1.600	0.020	0.020	1.038	1.495	0.000	0.447	5.420
10-14-2	Kapton/Polyimide	0.740	1.600	0.000	0.000	1.070	1.240	0.000	0.920	5.570
14-14-10	Silicone Rubber	0.900	0.880	2.000	0.840	1.672	1.440	0.000	0.000	7.732
A1-14-1	Polyvinyl Chloride	1.600	1.600	0.152	0.040	2.000*	1.532*	0.000	0.962	7.886
A2-14-1	Thermoplastic/Nylon	1.400	1.200	2.000	0.212	2.000	2.000*	1.000	1.000	10.812
A2-14-2	Thermoplastic	1.700	1.600	0.580	0.244	1.710	1.360	0.000	0.000	7.194
5-14-1	EPR/Hypalon	1.200	1.020	0.040	1.200	1.094	1.720	0.000	0.000	6.274
5-14-2	EPK	1.200	1.200	1.400	0.640	1.174	1.648	0.000	0.000	7.262

* Reflects penalty for exposed conductor.

TABLE 6-5. CONTINUED

SAMPLE NUMBER	INSULATION MATERIAL	IGNITION TIME (SEC)		AFTERFLAME/GLOW (SEC)		FLAME DAMAGE (IN)		CONVEY FLAME ? YES OR NO 1.0 OR 0	POST FLAME DIELECTRIC 6KV TO 0 0 TO 1.0	FACTOR SUMMATION 0 TO 14
		VERTICAL 0 TO 2.0	HORIZONTAL 0 TO 2.0	VERTICAL 0 TO 2.0	HORIZONTAL 0 TO 2.0	VERTICAL 0 TO 2.0	HORIZONTAL 0 TO 2.0			
AWG 12										
12-12-3	Tefzel	1.100	1.000	0.192	0.000	1.586	1.272	0.000	0.047	5.197
12-12-4	Halar	1.400	1.200	0.000	0.000	1.600	1.360	0.000	0.975	6.535
AWG 10										
12-10-3	Tefzel	1.060	0.800	0.120	0.000	1.834	1.360	0.000	0.780	5.954
AWG 8										
1-8-1	Silicone Rubber	1.200	1.000	1.360	0.440	1.200	1.632	1.000	0.372	8.204
3-8-1	Tefzel/Polyimide	0.800	1.200	0.060	0.000	1.595*	1.224	0.000	0.858	5.737
3-8-2	Kapton	0.000	0.000	0.000	0.000	0.800	1.136	0.000	0.000	1.936
4-8-1	Polyvinyl Chloride	1.300	1.000	0.100	0.052	1.270	1.712	0.000	0.737	6.171
6-8-1	Polyolefin	1.100	1.200	2.000	2.000	1.176	2.000	0.000	0.612	10.088
9-8-2	Silicone Rubber	0.000	0.400	0.520	0.000	1.184	1.872	1.000	0.000	4.976
10-8-3	Tefzel	1.000	0.680	0.080	0.000	1.710*	1.456	0.000	0.850	5.776
11-8-2	Polyolefin	1.400	1.040	2.000	1.520	1.246	1.680	0.000	0.717	9.603
13-8-1	Kapton/Nomex	0.000	0.680	0.000	0.000	1.290	1.480	0.000	0.000	3.450
AWG 6										
11-6-2	Polyolefin	1.100	1.120	2.000	1.040	1.354	1.792	0.000	0.850	9.256
AWG 4										
1-4-1	Silicone Rubber	1.000	0.760	0.000	0.000	1.660	1.752	1.000	0.000	6.172
6-4-1	Polyolefin	1.000	0.800	2.000	2.000	1.316	2.000	0.000	0.760	9.876
9-4-2	Silicone Rubber	1.000	0.400	0.000	0.000	1.470	2.000	1.000	0.000	5.870
10-4-1	Teflon (TFE)	0.350	0.000	0.000	0.000	1.710*	1.552	0.000	0.900	4.512
13-4-1	Kapton/Nomex	0.000	0.400	0.000	0.000	1.100	1.672	0.000	0.000	3.172

* Reflects penalty for exposed conductor.

TABLE 6-5. CONTINUED

SAMPLE NUMBER	INSULATION MATERIAL	IGNITION TIME (SEC)		AFTERFLAME/GLOW (SEC)		FLAME DAMAGE (IN)		CONVEY FLAME? YES OR NO 1.0 OR 0	POST FLAME DIELECTRIC 6KV TO 0 0 TO 1.0	FACTOR SUMMATION 0 to 14
		VERTICAL 0 TO 2.0	HORIZONTAL 0 TO 2.0	VERTICAL 0 TO 2.0	HORIZONTAL 0 TO 2.0	VERTICAL 0 TO 2.0	HORIZONTAL 0 TO 2.0			
AWG 3 10-3-3	Tefzel ①	0.660	0.052	0.046	0.000	2.000	2.000	0.000	1.000	5.758
AWG 2 A7-2-1	Polyethylene	0.000	0.200	2.000	0.060	2.000	2.000	1.000	0.000	7.260
AWG 2/0 3-00-3	Kapton/Composite Tapes	0.000	0.000	0.000	0.000	0.000	0.000	0.000	0.193	3.209
6-00-1	Polyolefin	0.720	0.120	2.000	2.000	1.224	1.943*	0.000	0.570	9.353
10-00-3	Tefzel	0.200	0.000	0.000	0.006	1.870*	2.000	0.000	1.000	5.076
11-00-1	Polyolefin	0.600	0.800	2.000	1.720	1.670	2.000	0.000	0.225	9.015
15-00-1	Hypalon	0.960	0.900	2.000	2.000	1.730	2.000	0.000	0.000	9.590
A5-00-3	Polyethylene	0.000	0.000	2.000	2.000	1.460	2.000	0.000	0.000	7.460
A7-00-2	Neoprene	0.800	0.600	0.000	0.040	1.686	2.000	0.000	0.000	5.126
AWG 3/0 A5-000-4	Syn.Rub./Neoprene	0.400	0.500	2.000	2.000	1.920	2.000	0.000	0.000	8.820
250 MCM A2-250-2	Thermoplastic	1.400	1.600	0.280	0.600	2.000	2.000	0.000	0.000	7.880
500 MCM 4-500-1	Polyvinyl Chloride	0.980	0.160	0.000	0.000	1.842	2.000	0.000	0.303	5.285
10-500-4	Teflon (PTFE)	0.000	0.000	0.000	0.000	1.727*	2.000	0.000	1.000	4.727
11-500-1	Polyolefin	0.760	0.040	2.000	2.000	2.000	2.000	0.000	0.418	9.218
A4-500-1	Rubber/PVC	1.150	0.800	0.360	0.220	2.000	2.000	0.000	0.000	6.530
A4-500-2	Rubber/Lead	0.000	0.000	1.100	0.680	1.540	2.000	0.000	0.000	5.320
1000 MCM A4-1000-3	Polyvinyl Chloride	1.200	1.400	0.560	0.680	2.000	2.000	0.000	0.000	7.840
2000 MCM A3-2000-3	EPR/Neoprene	0.000	0.000	1.940	1.840	2.000	2.000	0.000	0.000	7.780

① Fisher burner is severe on smaller wires * Reflects penalty for exposed conductor.

TABLE 6-6. SUMMARY OF LUMPED FACTORS, WIRES AWG 4 OR SMALLER

RANK	INSULATION MATERIAL (No. of Samples)	IGNITION TIME		AFTER FLAME/GLOW		FLAME DAMAGE		CONVEY FLAME YES OR NO 1.0 OR 0	POST FLAME DIELECTRIC 6 kv TO 0 0 TO 1.0	FACTOR SUMMATION 0 to 14
		VERTICAL 0 TO 2.0	HORIZONTAL 0 TO 2.0	VERTICAL 0 TO 2.0	HORIZONTAL 0 TO 2.0	VERTICAL 0 TO 2.0	HORIZONTAL 0 TO 2.0			
1	Asbestos (1)	0.000	1.000	0.000	0.020	0.814	1.240	0.000	0.623	3.697
2	Kapton (9)	0.664	1.231	0.011	0.000	1.139	1.312	0.000	0.499	4.856
3	Mica (1)	0.800	1.600	0.020	0.020	1.038	1.495	0.000	0.447	5.420
4	Teflon (7)	1.213	1.160	0.000	0.000	1.261	1.446	0.143	0.906	6.129
5	EPR/Hypalon (1)	1.200	1.020	0.040	1.200	1.094	1.720	0.000	0.000	6.274
6	Halar (1)	1.400	1.200	0.000	0.000	1.600	1.360	0.000	0.975	6.535
7	Tefzel (10)	1.270	1.260	0.106	0.037	1.832	1.651	0.000	0.853	7.009
8	EPR (1)	1.200	1.200	1.400	0.640	1.174	1.648	0.000	0.000	7.262
9	Silicone Rubber (12)	1.133	1.111	0.690	0.336	1.372	1.614	0.750	0.106	7.112
10	PVC (8)	1.625	1.565	0.372	0.152	1.746	1.579	0.000	0.808	7.847
11	Polyester (2)	1.710	1.600	0.134	0.032	2.000	2.000	0.000	1.000	8.476
12	Polyolefin (8)	1.319	1.285	1.550	0.938	1.165	1.698	0.000	0.567	8.522
13	Thermoplastic (2)	1.550	1.400	1.290	0.288	1.855	1.680	0.500	0.500	9.063
14	Polyethylene (1)	1.000	1.080	2.000	2.000	2.000	2.000	1.000	1.000	12.080

* Caution. It is emphasized that all materials of the same generic name may not behave the same in a flame situation, and that some of the materials in this table were ranked using the test results from one sample.

Two samples of polyester-insulated wire were tested. This material ignited readily and was almost entirely consumed by the flame.

Wires insulated with polyolefin performed about average, with the exception of afterflame and/or glow which was usually below average and the PFD which was better than most materials.

Those wires insulated with PVC ignited readily. Samples 14-20-1 through 14-20-4 and 14-20-6 appear to be damaged excessively. The first three have a marginal PFD, with some specimens having exposed copper conductors. A1-14-1 is similar to the "14" samples. Samples 4-16-1, 4-8-1 and 4-500-1 have an apparent better quality of insulating material. However, 4-16-1 glowed in excess for an AWG 16 wire. The insulation on A4-1000-3 burned to the extent that the copper conductor was exposed on 75 percent of the vertical test specimens.

Of the twelve silicone rubber insulated samples, only one was not jacketed with one or more other materials. Four of the samples were jacketed with polyolefin, five with fiberglass braid, and two with fiberglass/terylene. The majority of the samples ignited readily due to the jacket material or the saturant, as in the case of the high temperature lacquer in some of the fiberglass braids. The terylene burned rapidly within the envelope of the burner flame. As silicone rubber burns, it tends to expand, get brittle, and flake away from the wire. An outer covering such as fiberglass tends to prevent flaking. However, some fine bits of the material appear to force themselves out through the mesh of the braid in the shape of hairy protrusions. The polyolefin jackets tend to absorb the thermal punishment of the flame for a short time, but it too flakes and falls causing the cotton pad to ignite and is said to convey flame. This is also true of the two larger fiberglass-coated wires (9-8-2 and 9-4-2), in that large globs of the glowing hairy protrusions also fall on the cotton and cause it to burn. All silicone rubber insulated wires had good PFD values.

Teflon is of two types, FEP and PTFE (TFE). The FEP teflon melts and drips from the conductor. Sample 10-500-4 is a very good example of this. The material is consumed by sublimation, but as the teflon cools it cracks, exposing the wire. On larger wires such as 10-4-1, the cracks were as wide as 3/32 inch. There was no afterflame and/or glow and no conveyance of flame.

Of the 12 Tefzel-insulated samples, only samples 3-20-1 and 3-8-1 had other materials included in the construction. These samples had a polyimide coat over the Tefzel. Approximately 50 percent of the samples exhibited bare copper wire after the tests. Five samples had marginal to good PFD values. Afterflame and/or glow was five seconds less for all samples. Flame damage was more pronounced on samples 12-16-3, 12-12-3, 12-10-3 and 10-8-3.

There were approximately ten other samples of various rubber insulating materials. Samples A5-14-1 and A5-14-2 both have thick insulation and are insulated with EPR/Hypalon and EPR. They had very high PFD. This instance emphasizes that the heavily insulated wires withstand the 15/15/15 vertical flame test with ease. One sample of A5-14-1 was exposed 20/15/20 (an extra 5 seconds), and the afterglow increased from 1 to 45 seconds. During the increased flame exposure, the Hypalon jacket was damaged to the point that the EPR was caused to burn and smolder as it did on the 30 second horizontal test. A sample of A5-14-2 was exposed for a like amount of time (20/15/20), but there was no drastic change in performance from the 15/15/15 exposure as there is no protective jacket on this construction.

Sample A5-000-4 is insulated with synthetic rubber/chloroprene. It ignited and burned with a bright orange flame and considerable smoke. The jacket split open and flaked off, but there appeared to be insignificant damage to the inner insulation material. Afterglow was two to three minutes.

Sample A4-500-1 is insulated with synthetic rubber/PVC. The jacket ignited, burned readily, and was damaged severely, but a black cloth tape under the jacket appeared to protect the primary insulation from the flame. The PFD was greater than 50 kV.

Samples A7-00-2 and A3-2000-3 were insulated with EPR/Neoprene. The jacket on A7-00-2 appeared to expand until the wire was about 1.5 to 2.0 times its original diameter and formed a very rough surface. Though there was little apparent glow, the specimen smoked for approximately 30 seconds after removal of the flame. After about 40 seconds on horizontal tests, there was a bulge under the jacket followed by a "pop" as it exploded, releasing a shower of sparks. Sample A3-2000-3 and the Fisher burner are a mismatch. The outside diameter of this wire is 2.35 inches. When the burner is brought up to the test specimen, the flame only attacks the surface area on the side next to the burner. Despite this shortcoming, during a 20 minute horizontal flame exposure, the heavy jacket of neoprene (0.137 in.) was destroyed

and the primary insulation was damaged. The PFD was still good. The afterglow was approximately 90 seconds on both the vertical and horizontal.

Sample A4-500-2 has a synthetic rubber insulation and a tenth inch lead sheath. Considerable exposure was required to melt the lead before the flame could attack the insulation. PFD tests were not performed because of the lead sheath. Afterglow was less than one minute.

A large assortment of multiconductor cables were received, many of which had little basis for comparison other than the generic relationship of the basic insulation. Because of the large difference in construction and size, it was very difficult to determine what test flame exposure time should be used. In many cases more than one time was used for both the vertical and horizontal flammability tests. Usually, if a certain exposure caused a minimal amount of damage, the time was increased, and if necessary, increased again. In some samples, the orientation of the sample itself can make a difference in the test results. Some of the telephone cables have shields which are constructed with a lap that runs parallel to the axis of the cable. If this lap is placed on the bottom side of the test specimen, the molten insulation material (some of it does melt) can "run out" of the lap and provide fuel for the flame. If the lap is placed on the top of the specimen, the performance may be altogether different. Test specimens were placed at random and notes were added to the data sheets, if necessary.

Two cables were insulated with silicone rubber. The smaller, 2-2X16-1, is designed for use in fire hazard areas. It is better than average from an ignition standpoint, but it flames for a considerable time after the gas flame is removed. The larger, A6-4X16-1, is insulated with silicone rubber covered by a fiberglass braid on each wire, then bound together with a mylar tape and covered with a glass braid. This material exhibited good ignition characteristics, but also flamed for a time after the gas flame was removed.

Four samples were insulated with Tefzel plus other materials. This material seems to perform well if it has a jacket to protect it from the flame. Sample 3-7X20-1 is made up of seven AWG 20 wires without a jacket. Though each wire has a polyimide coat over the Tefzel, it melts and runs down the specimen and small amounts of exposed wire are visible.

Sample 12-3X16-1 burned readily, exposing large lengths of the braided copper shield. There was little afterflaming or glow. Each conductor of sample 13-7X14-2 was insulated by mica tape, then covered by Tefzel, and the seven conductor cable is jacketed with Tefzel. At the end of the flammability tests, the majority of the Tefzel had melted and dripped from or been consumed by the flame, leaving considerable exposed mica tape wrapped wires. Sample A3-19X12-3 consists of Tefzel insulated wires jacketed with Neoprene. This jacket burns readily and smokes, but the char formed tends to provide protection for the inner materials. It should be noted that for a two minute horizontal test (flame exposure), there were flames for 64 seconds after the gas flame was removed, followed by a glow for another 60 seconds. It can probably be said that during some of the longer exposures, all of the combustibles have been consumed and so there is no afterflame.

Two samples were insulated with Kapton. Sample 3-7X20-2, a small cable made without a jacket, and 13-7X12-3 both performed well in flame, considering their construction.

There are several cables that were insulated with polyethylene and jackets of polyethylene, Neoprene or PVC. These samples are 4-7X12-1, A2-6/2X19-4, 4-7X12-2, A7-6X19-4, A7-2419-5 and A5-MX19-5. Samples 4-7X12-1 and 4-7X12-3 performed about average and were accompanied by considerable smoke. The polyethylene jacket on 4-7X12-1 gave off a lot of sparks and little jets of flame radially from the wire. Cable sample A2-6/2X19-4 had a polyethylene jacket over a copper shield and was very flammable. All of the jacket material burned and dripped, leaving only the shield and inner materials remaining. Sample A7-6X19-4 behaves in a manner similar to the sample just previously described. Flames from all test specimens had to be extinguished. Samples A7-24X19-5 and A5-MX19-5 are telephone cables that are grease impregnated. Their jackets burned, and in time the grease came out and fed the flame, but this takes considerable time due to the metallic shields included in their construction.

Sample 13-7X14-1 was of an identical construction to 13-7X14-2 (described previously) except that the insulation material was Teflon (FEP) instead of Tefzel. The FEP melted and dripped, exposing occasional bits of Mica tape wrapped wires on vertical tests, and most of them within the flame envelope on horizontal tests. The mica tape remained on the wire.

Samples A3-7X14-1 and A3-7X14-2 are synthetic rubber/Neoprene insulated. The jacket material of both samples burn readily and smoked. The char from the jacket on -1 tends to build up a protective barrier which is approximately 75 percent larger than the original diameter. Specimens continue to smoke for approximately 2 minutes after the flame is removed, but there is no flaming or glowing. The jacket of sample -2 drops flakes and pieces of burning material during the whole test but does not ignite the cotton pad. The jacket is completely destroyed (on flame side) after the 3 minute horizontal flame test, exposing individual wire insulation and jute filler material. A snapping noise from within the specimen and falling sparks continue for two minutes after the flame is removed.

Sample A3-7X14-4 is insulated with Halar. It burns readily, but the flame nearly extinguishes after 45 seconds. There was very little afterflame or glow.

Samples 6-7X12-1 and A3-7X14-5 are both insulated with polyolefin, but manufactured by different companies. In general they perform comparably. They both burn rather readily, smoke considerably, and glow in excess after the flame has been removed.

A sample of slotted coaxial cable, A7-COAX-3, insulated with a jacket of polyethylene was tested. The dielectric material is a foam of unknown makeup. When a specimen is exposed to the flame with the slots on the flame side, the molten foam feeds the flame and there is afterflame or glowing which may last for several minutes.

Eleven of these multiconductor cables were considered comparable. Table 6-7 contains factors, described in the forepart of this section, for the parameters of these 11 cables at all the different flame-exposure times. The summation of the factors in Table 6-7 is shown in Table 6-8 in an attempt to determine the ranking of these 11 multiconductor cables for their flammability performance.

6.2 Smoke Test Results

The raw data resulting from the smoke test program was assimilated by a computer and the data presented by two methods: (a) a printout of actual values for all parameters recorded and calculated, and (b) a graphical display of specific optical density versus time. Figure 6-2 illustrates a typical example of the printed data, and Figure 6-3 illustrates the content of graphical displays obtained.

TABLE 6-7. MULTICONDUCTOR CABLE FLAMMABILITY TEST COMPARISON

SAMPLE NUMBER	INSULATION MATERIALS	FLAME EXPOSURE TIME (SEC.)	IGNITION TIME (SEC)		AFTERFLAME/GLOW (SEC)		FLAME DAMAGE (IN)		CONVEY FLAME? YES OR NO 1.0 OR 0	FACTOR SUMMATION	
			VERTICAL 0 To 2.0	HORIZ. 0 To 2.0	VERTICAL 0 To 2.0	HORIZ. 0 To 2.0	VERTICAL 0 To 2.0	HORIZ. 0 To 2.0			
4-7x12-1	Polyethylene/ Polyethylene	180		1.360		0.400		1.500	0.000	3.260	
		300		1.360		0.160		1.560	0.000	3.080	
		600		1.360		1.000		1.640	0.000	4.000	
4-7x12-2	Polyethylene/ Neoprene	90/15/90	0.450		0.120		1.800		0.000	2.370	
		120/15/120	0.450		0.020		1.910		0.000	2.380	
6-7x12-1	Polyolefin/ Polyolefin	180		1.400		0.280		1.480	0.000	3.160	
		300		1.400		0.140		1.443	0.000	2.983	
		600		1.400		0.480		1.660	0.000	3.540	
6-7x12-1	Polyolefin/ Polyolefin	60/15/60	0.600		0.080		1.540		0.000	2.220	
		90/15/90	0.600		1.960		1.760		0.000	4.320	
		120/15/120	0.600		0.740		1.790		0.000	3.130	
13-7x14-1	Teflon(FEP)-Mica/ Teflon(FEP)	180		1.400		2.000		1.592	0.000	4.992	
		300		1.400		2.000		1.672	0.000	5.072	
		600		1.400		2.000		1.680	0.000	5.080	
13-7x14-1	Teflon(FEP)-Mica/ Teflon(FEP)	90/15/90	0.600		1.740		1.660		0.000	4.000	
		120/15/120	0.600		1.700		1.640		0.000	3.940	
13-7x14-2	Tefzel-Mica/ Tefzel	180		0.960		0.000		1.088	0.000	2.328	
		300		0.960		0.000		1.208	0.000	2.168	
		60/15/60	0.260		0.000		1.240		0.000	1.500	
13-7x14-2	Tefzel-Mica/ Tefzel	90/15/90	0.260		0.000		1.686		0.000	1.946	
13-7x12-3	Kapton/Kapton	180		1.000		0.000		1.328	1.000	3.328	
		300				0.020		1.725	0.000	1.895	
		600				0.154		1.786	0.000	2.090	
13-7x12-3	Kapton/Kapton	180		1.500		0.000		0.880	0.000	2.380	
		300		1.500		0.000		0.920	0.000	2.420	
		600		1.500		0.000		1.088	0.000	2.588	
13-7x12-3	Kapton/Kapton	120/15/120	0.000		0.000		1.260		0.000	1.260	
		180/15/180	0.000		0.000		1.400		0.000	1.400	

① Listings such as "180" and "90/15/90" are interpreted as follows: "180" represents the horizontal flame exposure time, "90/15/90" represents the two vertical flame exposure times separated by a 15 second no-flame condition.

② It should be noted that there is practically nothing combustible remaining to flame/glow.

TABLE 6-7. CONTINUED

SAMPLE NUMBER	INSULATION MATERIALS	FLAME EXPOSURE TIME (SEC.)	IGNITION TIME		AFTERFLAME/GLOW		FLAME DAMAGE		CONVEY FLAME? YES OR NO 1.0 OR 0	FACTOR SUMMATION
			VERTICAL 0 To 2.0	HORIZ. 0 To 2.0	VERTICAL 0 To 2.0	HORIZ. 0 To 2.0	VERTICAL 0 To 2.0	HORIZ. 0 To 2.0		
A3-7x14-1	Syn.Rub./Neoprene	300 180/15/180	0.400	1.000	0.160	0.060	2.000	1.592	0.000 0.000	2.752 2.460
A3-7x14-2	Syn.Rub./Neoprene	180 240 300 180/15/180	0.760	1.380 1.380 1.380	2.000 2.000 2.000	2.000	1.926	1.448 1.480 1.480	0.000 0.000 0.000 0.000	4.828 4.860 4.860 4.686
A3-7x14-4	Halar/Halar	120 90/15/90	0.560	1.380	0.040	0.000	1.644	1.068	0.000 0.000	2.488 2.204
A3-7x14-5	Polyolefin/ Polyolefin	120 90/15/90	0.600	1.420	2.000	2.000	1.536	1.064	0.000 0.000	4.484 4.136
A6-4x12-1	Silicone Rub./ Glass	120 120/15/120	0.100	1.200	0.000	0.500	1.620	0.992	0.000 0.000	2.192 2.220

① See note 1 on sheet 1.

TABLE 6-8. MULTICONDUCTOR CABLE FLAMMABILITY RANKING

RANK	CABLE DESIGNATION/DESCRIPTION	PERFORMANCE FACTORS FOR VARIOUS EXPOSURE TIMES (SEC.)											MEAN NORMALIZED FACTOR
		HORIZONTAL TESTS					VERTICAL TESTS						
		120	180	300	600	60/15/60	90/15/90	120/15/120	180/15/180				
	NORMALIZING FACTOR	5.0	3.333	2.00	1.00	3.0	2.0	1.5	1.00				
1	13-7x12-3 Kapton/Kapton		2.380 7.933	2.420 4.840	2.588 2.588			1.280 1.920	1.400 1.400				3.736
2	A3-7x14-1 Synthetic Rubber Neoprene			2.752 5.504					2.460 2.460				3.982
3	13-7x14-1 Teflon (FEP)-Mica/ Teflon		2.048 6.826	2.168 4.336		1.500 4.500	1.946 3.892						4.889
4	4-7x12-1 Polyethylene/ Polyethylene		3.260 10.866	3.080 6.160	4.000 4.000	2.220 6.660	2.370 4.740	2.380 3.570					5.867
5	4-7x12-2 Polyethylene/ Neoprene		3.160 10.533	2.983 5.966	3.540 3.540	1.895 5.685	4.320 8.640	3.130 4.695					6.672
6	13-7x14-2* Tefzel-Mica/ Tefzel		3.328 11.092				2.090 4.180						6.986
7	A6-4x12-1 Silicone Rubber/ Glass	2.192 10.96						2.220 3.330					7.145
8	A3-7x14-4 Halar/Halar	2.488 12.44					2.204 4.408						8.424
9	6-7x12-1 Polyolefin/ Polyolefin		4.992 16.638	5.072 10.144	5.080 5.080		4.00 8.00	3.940 5.910					9.155
10	A-3-7x14-2 Synthetic Rubber/ Neoprene		4.828 16.085	4.860 9.720					4.686 4.686				10.164
11	A-37x14-5 Polyolefin/ Polyolefin	4.484 22.42					4.136 8.272						15.346
* 13-7x14-2 Conveyed flame during horizontal flammability test - the only cable to do so.													

ACCESSION NUMBER 77090371022058

SPECIMEN NUMBER - 3 TEST DATE - 03/30/77

SAMPLE NUMBER - 4-16-1-A
SAMPLE TITLE - PVC
SAMPLE ORIGIN - YORK
REQUESTOR - JACK YORK

RADIANT FLUX DENSITY - 2.50 WATTS/CM-CM
FLAME CONDITION - FLAMING

INITIAL WEIGHT - .00 GRAMS
FINAL WEIGHT - .00 GRAMS
WEIGHT LOSS - .00 GRAMS
PERCENT LOSS - .00

ELAPSED TIME (MIN)	SPECIFIC OPTICAL DENSITY	SMOKE OBSCURATION INDEX	
1.50	13.2	1.8	D _s 4 Min.
4.00	117.6	18.3	
END	597.1	45.1	

MAXIMUM SPECIFIC OPTICAL DENSITY - 597.1	(20.00 MINUTES)
MAXIMUM SMOKE_OBSCURATION_INDEX - 45.1	(20.00 MINUTES)

D_m

FIGURE 6-2 TYPICAL EXAMPLE PRINTED SMOKE TEST RESULTS (SHEET 1)

JAGS-YEAK	00480M00	XELAMING	YORK	D _s 4 Min.	D _m
2.50	2.54	2.54	574.2	1.2	1.7
572.4	39.0	43.8	9.57	12.1	13.9
240	.00	4.27	9.57	3.60	93.75
.0	.1	.5	.9	1.2	2.1
2.7	3.4	5.6	10.3	12.1	15.9
18.4	21.0	26.6	36.4	33.8	47.5
51.0	54.8	62.7	75.6	71.8	87.5
91.6	95.9	108.7	115.7	119.5	126.5
124.5	132.6	138.6	146.4	146.8	153.9
156.7	159.5	165.1	170.6	177.9	181.6
184.6	187.7	194.1	204.2	207.9	215.4
219.0	222.7	226.6	240.3	245.9	261.8
266.6	270.9	275.1	289.3	293.4	306.2
310.9	315.2	318.7	328.1	331.5	339.8
342.8	346.0	348.7	354.1	357.0	368.2
371.3	374.6	377.1	382.1	387.5	396.2
399.1	402.3	405.8	411.7	414.8	424.8
430.1	432.4	434.7	441.5	444.8	453.8
456.1	458.3	460.6	468.0	473.3	478.9
481.3	483.5	485.8	491.7	493.6	499.9
502.2	504.3	506.1	511.4	513.0	516.9
518.2	519.5	520.6	529.6	543.1	550.1
551.2	552.3	553.5	556.3	558.3	560.4
561.3	562.2	563.0	565.7	567.2	568.6
569.4	570.1	570.9	572.4	579.5	541.9
542.9	543.3	543.8	545.2	546.0	546.9
547.3	547.7	548.0	548.8	549.1	550.1
.0	.1	.2	.2	.3	.4
.4	.5	.6	.8	1.1	1.4
3.3	3.8	4.3	4.9	5.6	6.2
9.6	10.3	11.0	11.7	12.5	13.4
16.5	17.2	18.0	18.7	19.1	19.5
21.4	21.7	22.1	22.3	22.5	22.7
23.5	23.7	23.9	24.0	24.2	24.4
25.2	25.4	25.7	25.9	26.1	26.3
27.6	27.8	28.1	28.5	28.8	29.3
31.7	32.0	32.3	32.7	33.1	33.4
34.9	35.1	35.3	35.5	35.6	35.8
36.4	36.5	36.6	36.7	36.8	36.9
37.5	37.6	37.7	37.8	37.9	38.0
38.4	38.6	38.7	38.8	38.9	39.0
39.5	39.6	39.6	39.7	39.7	39.8
40.2	40.3	40.3	40.4	40.4	40.5
40.8	40.9	40.9	41.0	41.0	41.0
41.2	41.3	41.3	41.4	41.4	41.4
41.5	41.5	41.5	41.6	41.6	41.6
43.6	43.7	43.7	43.7	43.7	43.7
43.7	43.7	43.7	43.7	43.7	43.7
43.8	43.8	43.8	43.8	43.8	43.8
30.9	30.9	30.9	30.9	30.9	30.9
30.9	30.9	30.9	30.9	30.9	30.9

FIGURE 6-2 TYPICAL EXAMPLE PRINTED SMOKE TEST RESULTS (SHEET 2)

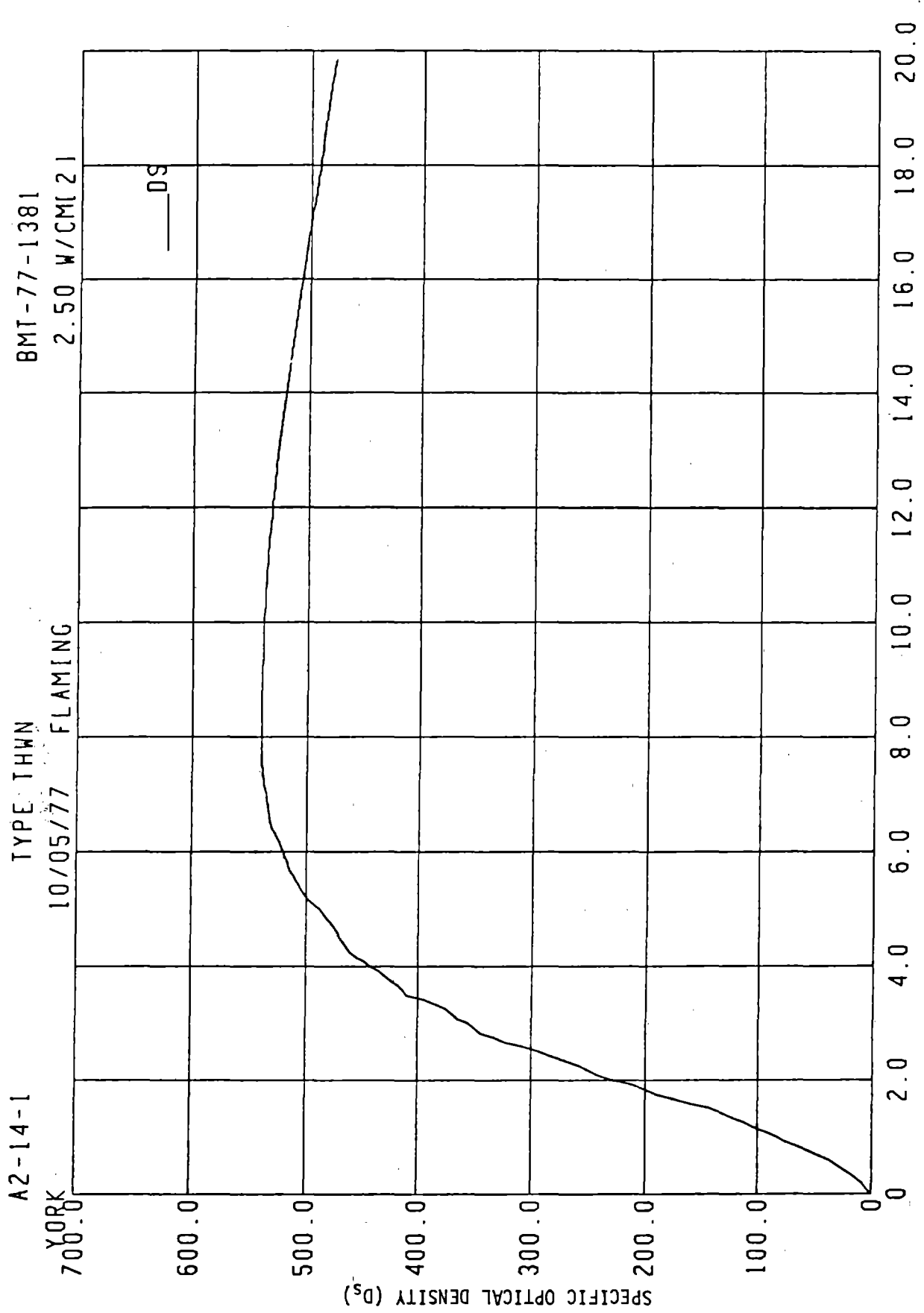

FIGURE 6-3 TYPICAL EXAMPLE GRAPHICAL SMOKE TEST RESULTS

To simplify the following discussion and analysis, the data have been further assimilated and rearranged as shown in Tables 6-9 through 6-11.

Table 6-9 contains the average maximum specific optical density (D_m) and that average value measured at the end of 4 minutes (D_s 4 min.) for each sample. As can be seen and as can be expected from the wide range of materials and constructions tested, there is a wide range of values, D_m varying between 0.2 and approximately 960, and D_s 4 min. between 0.0 and 500.

Table 6-10 and 6-11 present the average values of D_s at 4 minutes and D_m , respectively, for each sample grouped as a function of the basic insulation material. As can be seen from this chart, it is possible to separate wire insulating materials into three categories based on the values of D_m obtained from NBS Smoke Chamber Tests.

Category A	-	Low Smokers	D_m	0 - 50
Category B	-	Medium Smokers	D_m	51 - 150
Category C	-	Heavy Smokers	D_m	> 151

However, in certain cases the construction and size of the wire seem to have influence on whether the wire can be classified as Category A, B, or C. An analysis of the value of average D_m max versus wire size will be presented later in this discussion.

With respect to wire construction the following observations are considered noteworthy.

It is postulated that the relatively high D_m max for Kapton insulated wires 13-8-1A, 13-8-1B, 13-4-1A, and 13-4-1B is due to the effect of the nomex braid and saturant used as abrasion protection.

Significant improvement in smoke emission of Tefzel insulated wire is achieved by use of a polyimide top coat which seems to contain the smoke generated by the basic Tefzel. It is also noteworthy that the polyimide also prevents the Tefzel from dripping.

The burning of the combination of products used in the Halar insulated wire had

TABLE 6-9. SPECIFIC OPTICAL DENSITY TEST RESULTS

SAMPLE NUMBER	OPTICAL DENSITY		SAMPLE NUMBER	OPTICAL DENSITY		SAMPLE NUMBER	OPTICAL DENSITY		SAMPLE NUMBER	OPTICAL DENSITY	
	D _s 4 Min	Avg. D _m		D _s 4 Min	Avg. D _m		D _s 4 Min	Avg. D _m		D _s 4 Min	Avg. D _m
1-20-1	43.5	438.5	6-4-1A	352.6	460.2	11-6-2A	112.8	325.6	14-16-8A	26.0	298.9
1-16-1A	59.5	472.4	6-4-1B	373.0	571.2	11-6-2B	128.7	363.2	14-16-8B	51.3	73.0
1-16-1B	46.6	370.7	6-00-1A	299.0	365.7	11-00-2A	148.1	278.3	14-14-10	45.3	322.5
1-8-1A	49.1	369.5	6-00-1B	342.3	438.7	11-500-1	100.5	282.6	15-00-1	229.2	524.6
1-8-1B	54.7	316.0	6-7x12-1	4 5		11-500-1	173.2	522.8	A1-14-1	133.0	538.6
1-4-1A	31.5	309.7	6-7x12-1	514.0	957.0	12-20-1	0.3	0.9	A2-14-1	259.2	673.1
1-4-1B	32.1	221.4	8-16-1*			12-20-2	0.1	0.7	A2-14-2	442.4	542.6
2-14-1A	0.1	11.0	9-20-1	118.1	312.2	12-16-3A**	10.0	128.9	A2-250-2	316.7	515.0
2-14-2A	11.9	93.1	9-20-2	25.7	287.9	12-12-3A	2.7	100.6	A2-10x12-3	332.0	334.3
2-2x16-1	26.0	150.9	9-16-1A	151.3	344.6	12-12-4A	9.7	256.0	A2-6/2x19-4	14.7	240.1
3-20-1	3.4	20.8	9-16-1B	113.2	237.5	12-10-3A	10.0	130.2	A3-7x14-1	271.1	408.6
3-20-2	0.3	2.2	9-16-2A	16.2	242.1	12-10-3B	6.4	137.3	A3-7x14-2	279.4	473.7
3-8-1A	1.0	29.7	9-16-2B	22.1	254.3	12-3x16-1	3.0	341.5	A3-2000-3	296.6	469.9
3-8-1B	1.5	13.0	9-8-2A	33.3	322.7	13-20-1	0.2	0.6	A3-7x14-4	17.6	305.4
3-8-2A	0.2	0.5	9-8-2B	36.6	214.0	13-16-1A**	1.6	1.9	A3-7x14-5	220.4	413.9
3-8-2B	0.0	0.3	9-4-2A	23.2	192.2	13-16-1B	0.0	0.2	A4-500-1	412.3	449.5
3-00-3A	0.2	0.4	9-4-2B	11.2	148.9	13-8-1A	1.6	40.9	A4-500-2	0.5	18.5
3-00-3B	0.2	0.4	10-20-1	0.3	5.5	13-8-1B	0.2	5.4	A4-1000-3	500.7	509.9
3-7x20-1	4.1	47.3	10-18-3	34.9	290.9	13-4-1A	0.1	13.5	A5-14-1	63.4	289.8
3-7x20-2	0.6	7.7	10-16-1A	0.4	1.8	13-4-1B	0.8	10.7	A5-14-2	71.8	266.2
4-16-1	123.3	579.2	10-16-1B	0.3	1.2	13-7x14-1	0.0	38.3	A5-00-3	0.2	103.2
4-8-1A	248.7	467.3	10-16-3A	16.4	244.0	13-7x14-2	36.4	434.9	A5-000-4	207.3	313.9
4-500-1	272.7	627.2	10-16-3B	8.9	195.3	13-7x12-3	0.6	4.2	A5-Mx19-5	267.2	346.5
4-7x12-1	217.4	795.3	10-4-1A	0.4	7.2	14-20-1	374.1	691.5	A6-4x12-1	54.9	367.0
4-7x12-2	223.1	607.3	10-4-1B	0.3	2.6	14-20-2	220.2	616.3	A7-2-1	0.4	243.3
5-20-1	44.4	203.0	10-00-3A	5.7	145.9	14-20-3	161.1	576.2	A7-00-2	73.2	345.0
5-16-3	30.6	316.5	10-00-3B	17.0	126.2	14-20-4	319.1	502.7	A7-Coax-3	85.7	164.2
5-16-2A	0.7	8.2	10-500-4	3.2	16.9	14-20-5	74.6	500.9	A7-6x19-4	0.6	253.8
6-20-1	346.8	611.6	11-20-1	157.8	441.5	14-20-6	312.5	601.9	A7-24x19-5	201.0	360.8
6-16-1A	267.0	440.8	11-16-1A	133.4	403.1	14-20-7	0.6	4.9			
6-16-1B	238.2	393.8	11-16-1B	181.9	641.0	14-20-8	21.3	209.2			
6-8-1A	381.1	610.2	11-8-2A	175.5	423.0	14-20-9	0.8	12.9			
6-8-1B	418.2	672.2	11-8-2B	194.0	340.5	14-16-7	0.4	2.9			

* Not tested because of insufficient material.

** Smoke data was exchanged for 12-16-3A and 13-16-1A.

TABLE 6-10. INSULATION TYPE VERSUS AVERAGE SPECIFIC OPTICAL DENSITY (D_S) AT 4 MINUTES

SAMPLE NUMBER	D _S	SAMPLE NUMBER	D _S	SAMPLE NUMBER	D _S	SAMPLE NUMBER	D _S
<u>KAPTONS</u>		<u>MICA</u>	11.9	<u>SILICONES (CONT'D)</u>		<u>PVC (CONT'D)</u>	
3-8-2B	0.0	2-14-2A*		1-8-1B*	54.7	A2-14-1*	259.2
13-16-1B	0.0			A6-4x12-1*	54.9	A5-Mx19-5*	267.2
13-4-1A*	0.1	<u>TEFZEL</u>		1-16-1A*	59.5	4-500-1	272.7
13-20-1	0.2	12-12-3A	2.7			14-20-6	312.5
3-8-2A	0.2	12-3x16-1	3.0	<u>POLYETHYLENES</u>		A2-250-2	316.7
3-00-1A*	0.2	10-00-3A	5.7	A5-00-3*	0.2	14-20-4	319.1
3-00-1B*	0.2	12-10-3B	6.4	A7-2-1	0.4	14-20-1	374.1
13-8-1B*	0.2	10-16-3B	8.9	A2-6/2X19-4*	14.7	A4-500-1*	412.3
3-20-2	0.3	12-16-3A	10.0	14-20-5	74.6	A2-14-2	442.4
3-7X20-3	0.6	12-10-3A	10.0	A7-COAX-3*	85.7	A4-1000-3	500.7
3-7X12-3	0.6	10-16-3A	16.4	4-7X12-1	217.4		
14-20-9*	0.8	10-00-3B	17.0	4-7X12-2*	223.1		
13-4-1B*	0.8	10-18-3	34.9			<u>POLYOLEFINS</u>	
13-16-1A	1.6	13-7X14-2*	36.4	<u>POLYESTERS</u>		11-00-2B	100.5
13-8-1A*	1.6	5-20-1	44.4	9-16-1B	113.2	11-6-2A	112.8
				9-20-1	118.1	11-6-2B	128.7
<u>TEFLONS (PTFE)</u>		<u>HALAR</u>		9-16-1A	151.3	11-16-1A	133.4
12-20-2	0.1	12-12-4A	9.7			11-00-2A	148.1
10-20-1	0.3	A3-7X14-4	17.6	<u>RUBBERS</u>		11-20-1	157.8
10-16-1B	0.3			A5-14-1*	63.4	11-500-1	173.2
10-4-1B	0.3	<u>SILICONES</u>		A5-14-2	71.8	11-8-2A	175.5
10-16-1A	0.4	9-4-2B*		A7-00-2*	73.2	11-16-1B	181.9
14-16-7	0.4	9-16-2A*	11.2	A5-000-4*	207.3	11-8-2B	194.0
10-4-1A	0.4	14-20-8*	16.2	A3-7X14-1*	271.1	A3-7X14-5	220.4
14-20-7	0.6	9-16-2B*	21.3	A3-7X14-2*	279.4	6-16-1B	238.2
		9-4-2A*	23.2	A3-2000-3*	296.6	6-16-1A	267.0
<u>TEFLONS (FEP)</u>		9-20-2*	25.7	A2-19X12-3*	332.0	6-00-1A	299.0
13-7X14-1*	0.0	2-2X16-1	26.0			6-20-1	342.3
10-500-4	3.2	14-16-8A*	26.0	<u>HYPALON</u>		6-20-1	346.8
		5-16-3A*	30.6	15-00-1	229.2	6-4-1A	352.6
<u>ASBESTOS</u>		1-4-1A*	31.5			6-4-1B	373.0
2-14-1A*	0.1	1-4-1B*	32.1	<u>POLYVINYL CHLORIDE (PVC)</u>		6-8-1A	381.1
5-16-2*	0.7	9-8-2A*	33.3	A7-6X19-4*	0.6	6-8-1B	418.2
		9-8-2B*	36.6	4-16-1A	123.3	6-7X12-1	514.0
<u>PCT</u>		1-20-1*	43.6	A1-14-1	133.0		
3-8-1A*	1.0	14-14-10	45.3	14-20-3	161.7	<u>LEAD JACKET</u>	
3-8-1B*	1.5	1-16-1B*	46.6	A7-24X19-5*	201.0	A4-500-2	0.5
3-20-1*	3.4	1-8-1A*	49.1	14-20-2	220.2		
3-7X20-1*	4.1	14-16-8B*	51.3	4-8-1A	248.7		

* Signifies a composite material.

TABLE 6-11. INSULATION TYPE VERSUS MAXIMUM SPECIFIC OPTICAL DENSITY (D_M)

SAMPLE NUMBER	D _M	SAMPLE NUMBER	D _M	SAMPLE NUMBER	D _M	SAMPLE NUMBER	D _M
<u>KAPTONS</u>		<u>MICA</u>		<u>SILICONES, (Cont.)</u>		<u>POLYOLEFINS (Cont.)</u>	
13-16-1B	0.2	2-14-2A*	93.1	1-20-1*		11-8-2A	423.0
3-8-2B	0.3	<u>TEFZELS</u>		1-16-1A*		6-00-1B	438.7
3-00-1A*	0.4	12-12-3A	100.6	<u>POLYESTERS</u>		6-16-1A	440.8
3-00-1B*	0.4	10-00-3B	126.2	9-16-1B		11-20-1	441.5
3-8-2A	0.5	12-16-3A	128.9	9-20-1		6-4-1A	460.2
13-20-1	0.6	12-10-3A	130.2	9-16-1A		11-500-1	522.8
13-16-1A	1.9	12-10-3B	137.3	<u>RUBBERS</u>		6-4-1B	571.2
3-20-2	2.2	10-00-3A	145.9	A5-14-2		6-8-1A	610.2
13-7x12-3	4.2	10-16-3B	195.3	A5-14-1*		6-20-1	611.6
13-8-1B*	5.4	5-20-1	203.0	A5-000-4*		11-16-1B	641.0
3-7x20-2	7.7	10-16-3A	244.0	A2-19x12-3*		6-8-1B	672.2
13-4-1B*	10.7	10-18-3	290.9	A7-00-2*		6-7x12-1	957.0
14-20-9*	12.9	12-3x16-1	341.5	A3-7x14-1*		<u>POLYVINYL CHLORIDES</u>	
13-4-1A*	13.5	13-7x14-2*	434.9	A3-2000-3*		A7-6x19-4*	253.8
13-8-1A*	40.9	<u>HALAR</u>		A3-7x14-2*		A5-Mx19-5*	346.5
<u>TEFLONS (PTFE)</u>		12-12-4	256.0	<u>POLYETHYLENES</u>		A7-24x19-5*	360.8
12-20-2	0.7	A3-7x14-4	305.4	A5-00-3*		A4-500-1*	449.5
12-20-1	0.9	<u>SILICONES</u>		A7-COAX-3*		4-8-1	467.3
10-16-1B	1.2	14-16-8B*	73.0	A2-6/2x19-4*		14-20-4	502.7
10-16-1A	1.8	9-4-2B*	148.9	A7-2-1		A4-1000-3	509.9
10-4-1B	2.6	2-2x16-1	150.9	14-20-5		A2-250-2	515.0
14-16-7	2.9	9-4-2A*	192.2	4-7x12-2*		A1-14-1	538.6
14-20-7	4.9	14-20-8*	209.2	4-7x12-1		A2-14-2	542.6
10-20-1	5.5	9-8-2B*	214.0	<u>POLYOLEFINS</u>		14-20-3	576.2
10-4-1A	7.2	1-4-1B*	221.4	11-00-2A		4-16-1	579.2
<u>TEFLONS (FEP)</u>		9-16-2A*	242.1	11-00-2B		14-20-6	601.9
10-500-4	16.9	9-16-2B*	254.3	11-6-2A		14-20-2	616.3
13-7x14-1*	38.3	14-16-8A*	287.9	11-8-2B		4-500-1	627.2
<u>ASBESTOS</u>		1-4-1A*	298.9	11-6-2B		A2-14-1*	673.1
5-16-2*	8.2	1-8-1B*	309.7	6-00-1A		14-20-1	691.5
2-14-1A*	11.0	5-16-3*	316.0	6-16-1B		<u>HYPALON</u>	
<u>PCT</u>		14-14-10	322.5	11-16-1A		15-00-1	524.6
3-8-1B*	13.0	9-8-2A*	322.7	A3-7x14-5		<u>LEAD JACKET</u>	
3-20-1*	20.8	A6-4x12-1*	367.0			A4-500-2	18.5
3-8-1A*	29.7	1-8-1A*	369.5				
3-7x20-1*	47.3	1-16-1B*	370.7				

* Signifies a composite material.

adverse effects on the NBS chamber. The entire interior of the chamber was coated with a deposit which required the use of "Brillo" pads before the chamber could be returned to normal use.

Tables 6-12 and 6-13 summarize the results presented in Tables 6-10 and 6-11 and attempt to generally rank the materials and construction based on their performance without compensating for the number of samples and wire size. This approach may raise some eyebrows among the purists. However, it appears that there is sufficient sensitivity using this approach to identify and separate the low, medium, and high smoke-emitting insulation/constructions.

An analysis will now be presented on the results of varying the lengths of larger gauge wire to provide the equivalent surface area or equivalent insulation mass of 10 feet of AWG 20 wire. The samples requested from suppliers were for AWG sizes 20, 16, 12, 8, 4, and 2/0, as well as 500 MCM and 7 conductor, AWG 12. While the wire manufacturers were very generous in furnishing samples, none of them sent all materials/constructions in all sizes. In some cases, one material was furnished in two, three, or four of the sizes, and in other cases all sizes were represented, but the materials were different. Hence, it is not possible to present a complete analysis for each material/construction received. The plots of D_S versus time are used in the analysis.

The first category of wire studied was a silicone rubber insulated wire with a cross linked modified polyolefin jacket. The baseline specimen was a 10 foot sample of AWG 20 wire having the designator 1-20-1. Wire 1-16-1A is AWG 16 of the same construction, but cut to length to provide the same surface area as the 10 feet of AWG 20. Wire 1-16-1B is also AWG 16 of the same construction, but in this case cut to length to provide the same insulation mass as the 10 feet of AWG 20 wire. The resultant curves of D_S versus time shown in Figure 6-4 compare very well over the entire range of data. The D_S for 1-16-1A wire differs from that of the 1-20-1 wire by +7.73 percent, while the D_S for 1-16-1B wire differs by -15.46 percent. Both of the AWG 16 wire lengths were wrapped around the comb in the same manner as the AWG 20 wire.

The correlation between the AWG 8 and the AWG 20 is not as good as that between AWG 16 and AWG 20. AWG 8 was cut into three inch lengths and stacked in the

TABLE 6-12 INSULATION MATERIALS IN ASCENDING ORDER OF SMOKE EMISSION
AT FOUR MINUTES

MATERIAL/CONSTRUCTION	NO. OF SAMPLES	SPECIFIC OPTICAL DENSITY (D _S) AT 4 MINUTES			
		MINIMUM	MAXIMUM	MEAN	STD. DEVIATION
Teflon (PTFE)	6	0.1	0.6	0.35	0.16
Asbestos	2	0.1	0.7	0.4	—
Kapton	10	0.1	0.8	0.5	0.29
Teflon (FEP)	2	0.0	3.2	1.6	—
Polyimide Coated Tefzel	3	1.25	4.1	2.9	—
Mica	1	11.9	11.9	11.9	—
Halar	2	9.7	17.6	13.65	—
Tefzel	9	2.7	44.4	18.2	15.9
Silicone	14	17.2	54.9	35.3	12.9
EPR	1	71.8	71.8	71.8	—
Polyethylene	7	0.2	223.1	88.0	96.6
Polyester	2	118.1	132.2	125.2	—
Polyolefin	13	120.8	514.0	256.6	122.2
Polyvinyl Chloride	17	0.6	500.7	268.6	125.7

TABLE 6-13 INSULATION MATERIALS IN ASCENDING ORDER OF SMOKE EMISSION

MATERIAL/CONSTRUCTION	NO. OF SAMPLES	MAXIMUM SPECIFIC OPTICAL DENSITY (D_M)				STD. DEVIATION
		MINIMUM	MAXIMUM	MEAN		
Teflon (PTFE)	7	.7	5.5	3.0	2.06	
Kapton	10	0.4	23.2	6.5	7.55	
Asbestos	2	8.2	11.0	9.6	—	
Teflon (FEP)	2	16.9	38.3	27.6	—	
Polyimide Coated Tefzel	3	20.4	47.3	29.8	—	
Mica	1	93.1	93.1	93.1	—	
Tefzel	9	100.6	434.9	221.0	113.6	
EPR	1	266.6	266.6	266.6	—	
Halar	2	256	305.4	280.7	—	
Silicone	14	150.9	438.5	285.4	89.2	
Polyester	2	291.5	344.6	318.1	—	
Polyethylene	7	103.2	795.3	379.2	258.3	
Polyolefin	13	280.4	957	496.3	172.2	
Polyvinyl Chloride	17	253.8	691.5	520.7	117.9	

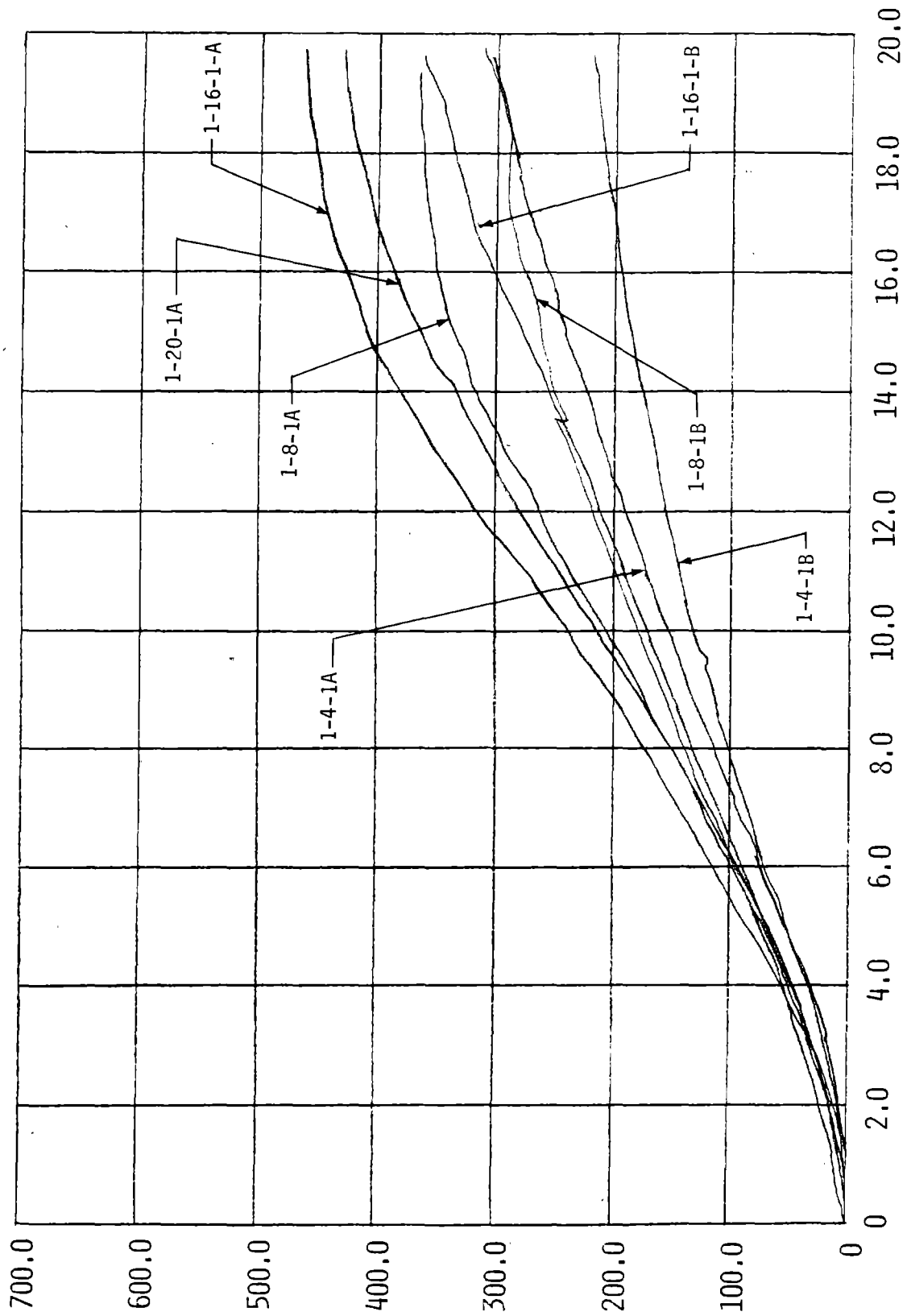

FIGURE 6-4. OPTICAL DENSITY PLOT COMPARISON (SILICONE RUBBER INSULATED/POLYOLEFIN JACKET)

holder. The number of lengths used was calculated to give the same surface area or insulation mass as the AWG 20 wire. Generally, the shapes of the curves are comparable. The 1-8-1A wire (surface area) differs from the 1-20-1A wire by -15.84 percent, approximately the same as the 1-16-1B wire. However, the 1-8-1B wire (equivalent insulation mass) differs by -27.94 percent.

There is a greater difference between the AWG 4 and the AWG 20. The 1-4-1A wire differs by -29.37 percent, while the 1-4-1B wire differs by -49.51 percent as compared to the 1-20-1 wire. In each case, the length based on surface area differed less than the length based on insulation mass. However, from the agreement in the general geometry of the curves and general value of D_m , it is not difficult to determine to which categories this wire insulation should be assigned.

Wire 3-20-1 was 10 feet of AWG 20 insulated with Tefzel and having a polyimide top coat. Wire 3-20-1 was analyzed with respect to the similarly constructed wires 3-8-1A and 3-8-1B. These wires produced relatively little smoke. Hence, apart from confirming that the unexpected did not happen, it appears that the absolute length of the sample versus wire size did not materially influence the final result or the final ranking of this construction. When the graphs contained in Figure 6-5 are visually compared, there appears to be little difference in the results.

Wire 3-20-2 was insulated with Kapton. It can be compared only with AWG 8 supplied by the same manufacturer. Again, because of the low smoke emission of these wires, the plots shown in Figure 6-6 hardly show any differences that can be attributed to anomalies in the size of the test specimen or that will affect the final ranking.

A cross-linked, modified polyolefin wire was submitted in sizes 20, 16, 8, 4, and 2/0, a range with which to make a good comparison. For some unexplained reason, the curve is erratic in the area of D_m and the computed value for D_S is 611.6. In order to minimize the effect of the anomaly, the curve was extrapolated between 18 and 20 minutes, and a D_S of 500 each used for calculations. The results of comparing the different specimens are shown in Figure 6-7.

With the exception of the AWG 2/0 wire, the difference between D_m for the various size surface areas was less than the difference based on insulation mass. However,

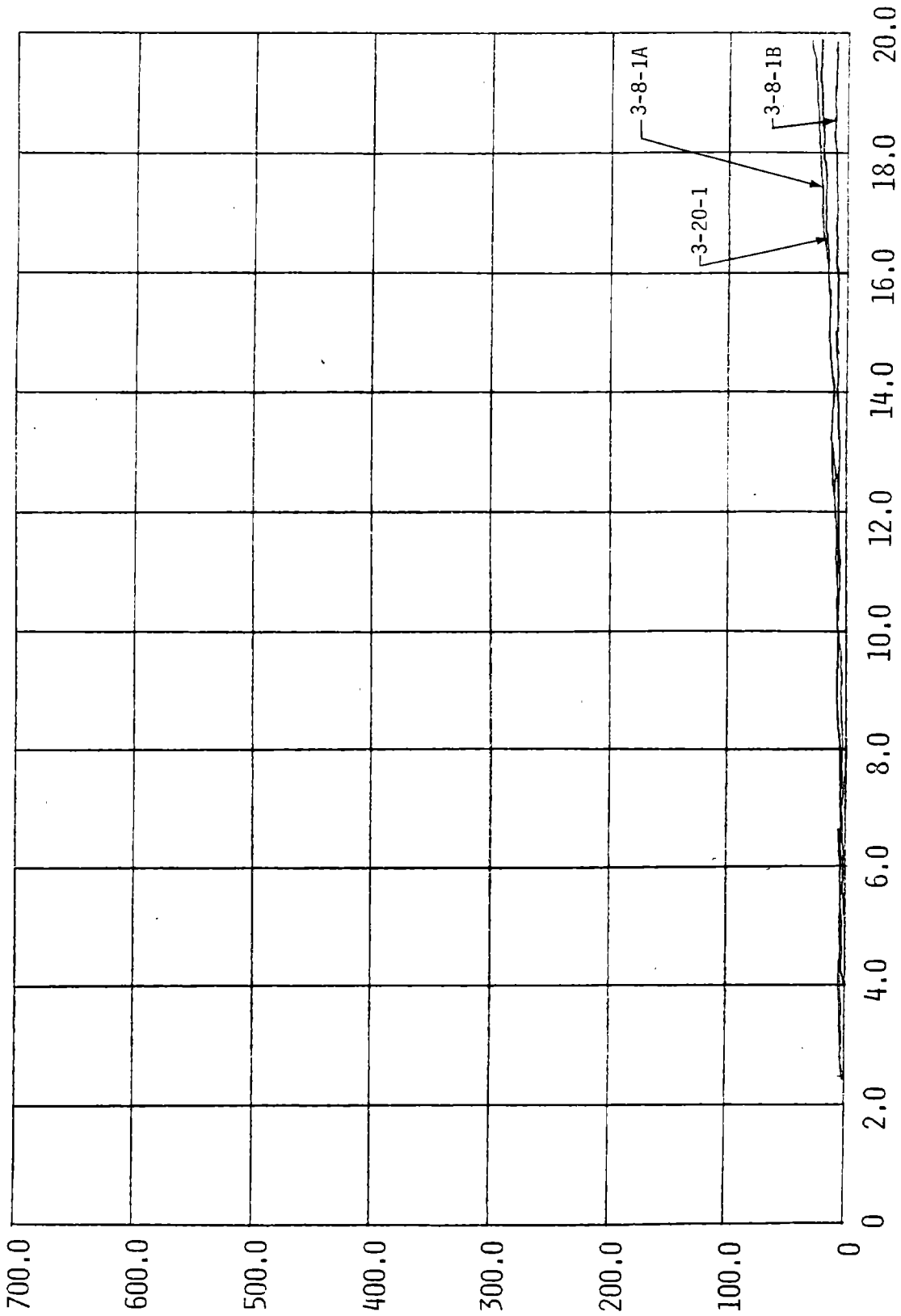

FIGURE 6-5. OPTICAL DENSITY PLOT COMPARISON (TEFZEL INSULATED/POLYOLEFIN COATED)

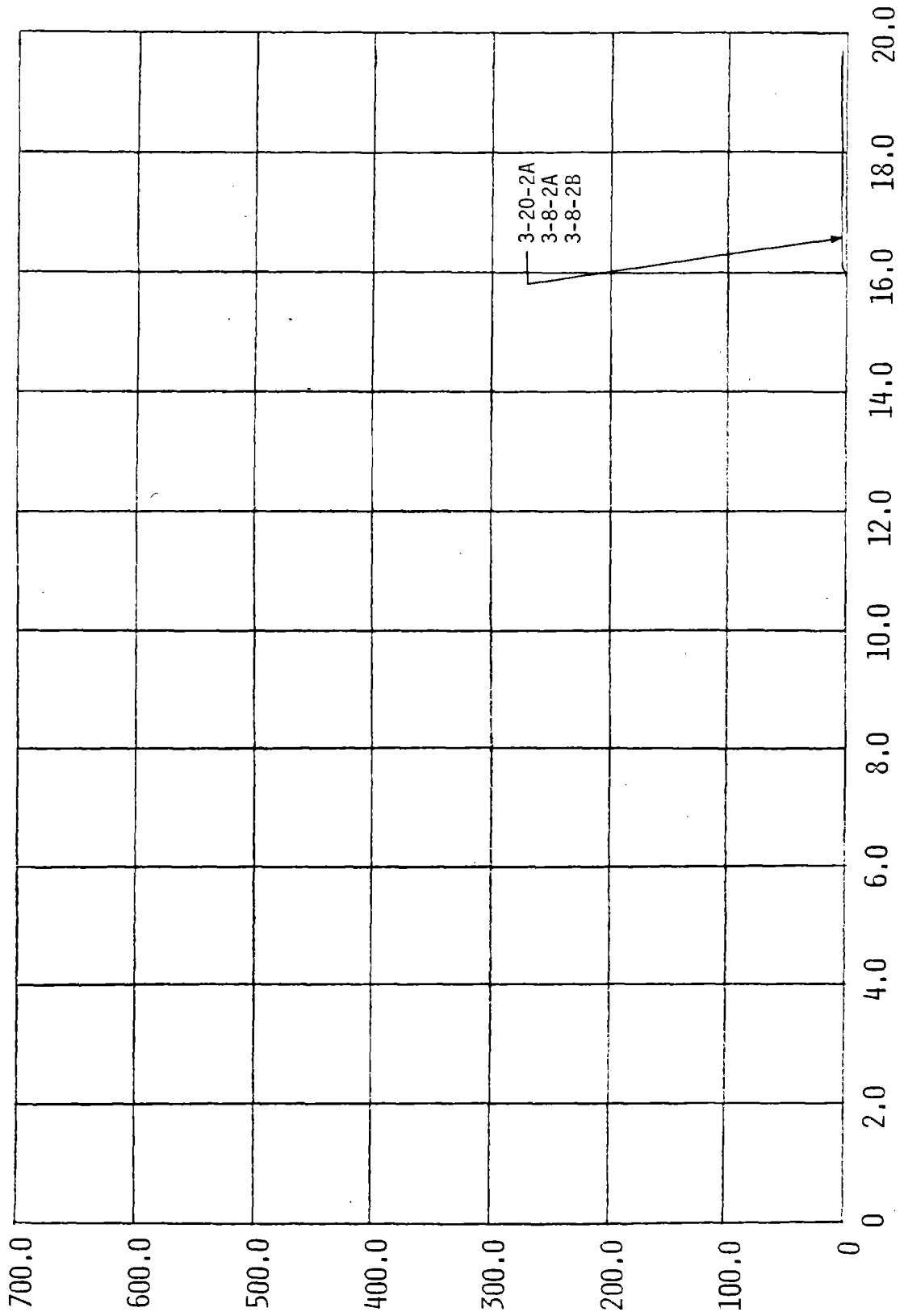

FIGURE 6-6. OPTICAL DENSITY PLOT COMPARISON (KAPTON INSULATED)

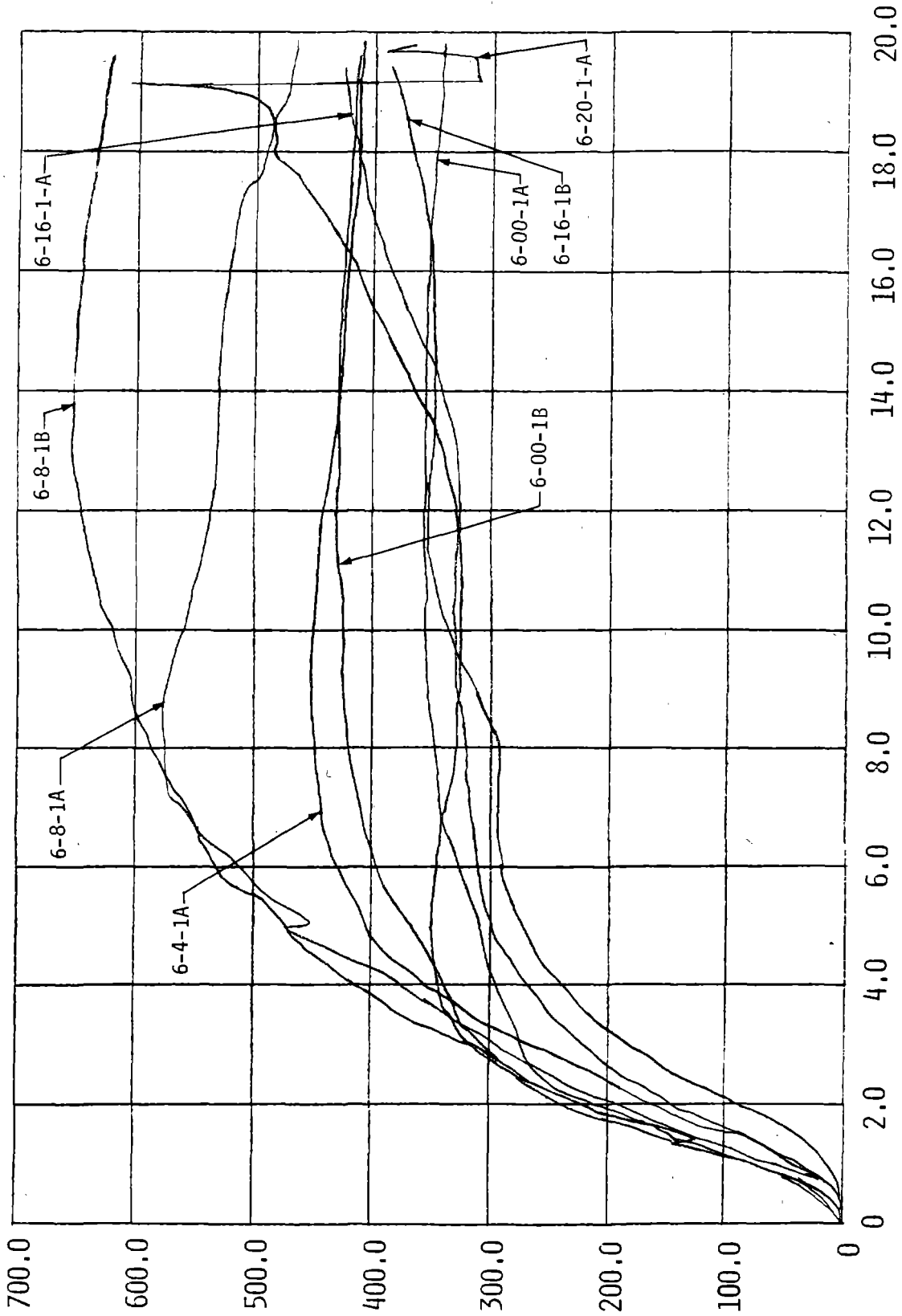

FIGURE 6-7. OPTICAL DENSITY PLOT COMPARISON (POLYOLEFIN INSULATED)

again the difference in the absolute values obtained for the different gauge sizes will in no way affect the category to which this wire material/construction would be assigned.

Wires 9-20-2, 9-16-2 (A & B), 9-8-2 (A & B), and 9-4-2 (A & B) were insulated with silicone over which a saturated glass braid was woven. The results of these tests have also been plotted and are shown in Figure 6-8.

The geometry of these curves are comparable. The AWG 16 wire showed a greater difference when comparing surface area to AWG 20. However, the others showed less difference with surface area comparisons than with insulation mass. Here again, the results clearly indicate the category to which this wire should be assigned.

A variety of wire sizes and materials were submitted by wire manufacturer "10". Wire 10-20-1 can be compared with wires 10-16-1A, 10-16-1B, 10-4-1A, and 10-4-1B. These wires were insulated with PTFE Teflon, the AWG 4 wires having a mineral fill.

The Teflons are very low smoke producers, and as the plots of the data reveal in Figure 6-9, little effect of sample size is evident.

Based on the foregoing and a similar review of the data from the other like groupings of wire, it can be concluded that the method of using either surface area or insulation mass equivalent to that of the baseline standard can reveal results which are sufficiently accurate to establish the category to which a particular wire construction/insulation can be assigned. In the case of this study, 10 ft of 20 AWG was used as the baseline. Since 20 AWG is not in common usage in the rapid transit industry, 6 ft of 14 AWG is perhaps a more useful baseline.

6.3 Circuit Integrity

6.3.1 Single Conductor Wires

Circuit integrity tests were performed on all single conductor wires AWG 8 and smaller and on all multiconductor cables. The test performed on the single conductor wire was the BIW test method described in Section 4.4.5.1. The multiconductor cables were tested by the method described in Section 4.4.5.2, which uses the Fisher burner.

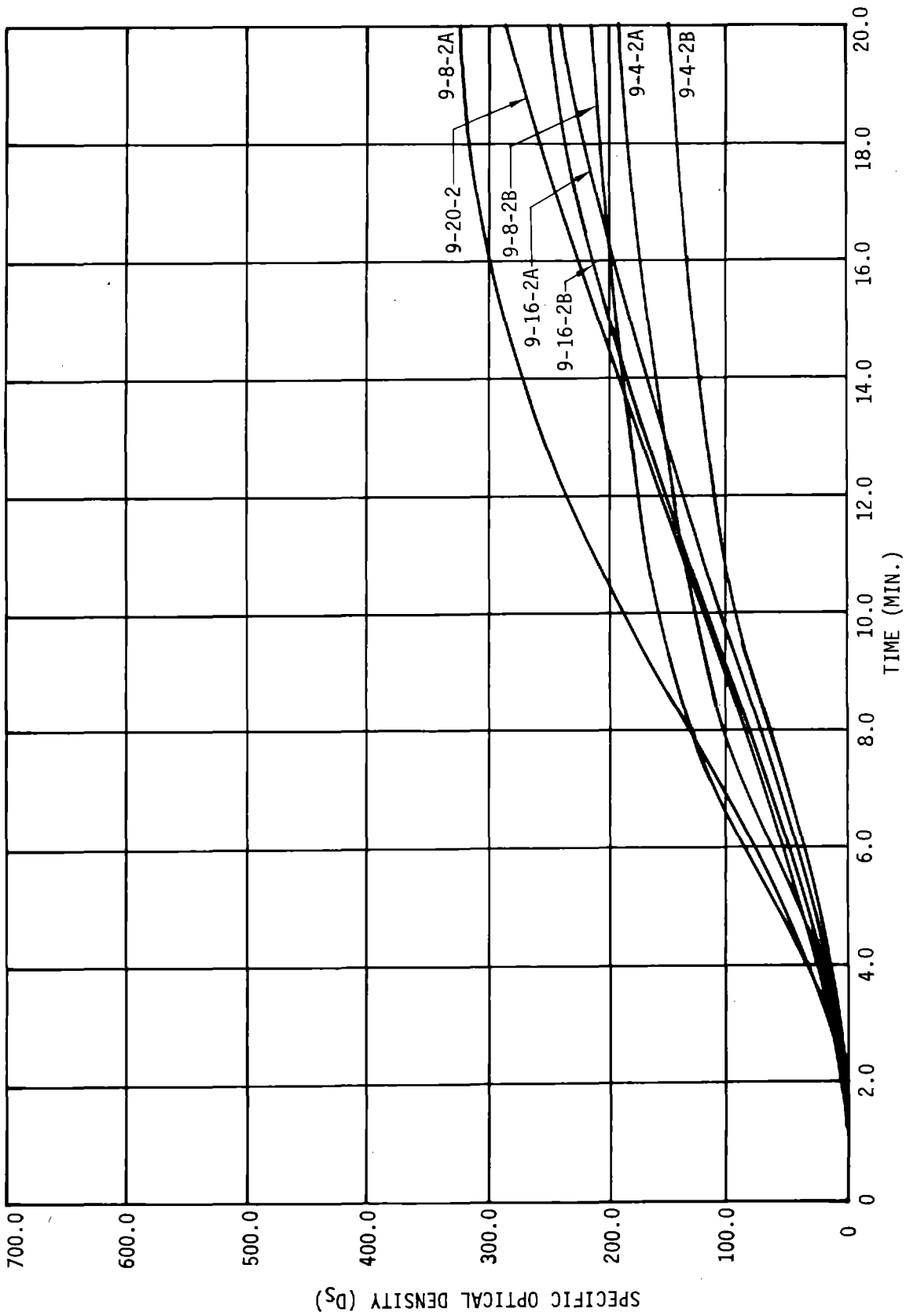

FIGURE 6-8. OPTICAL DENSITY PLOT COMPARISON (SILICONE RUBBER INSULATED/GLASS BRAID JACKET)

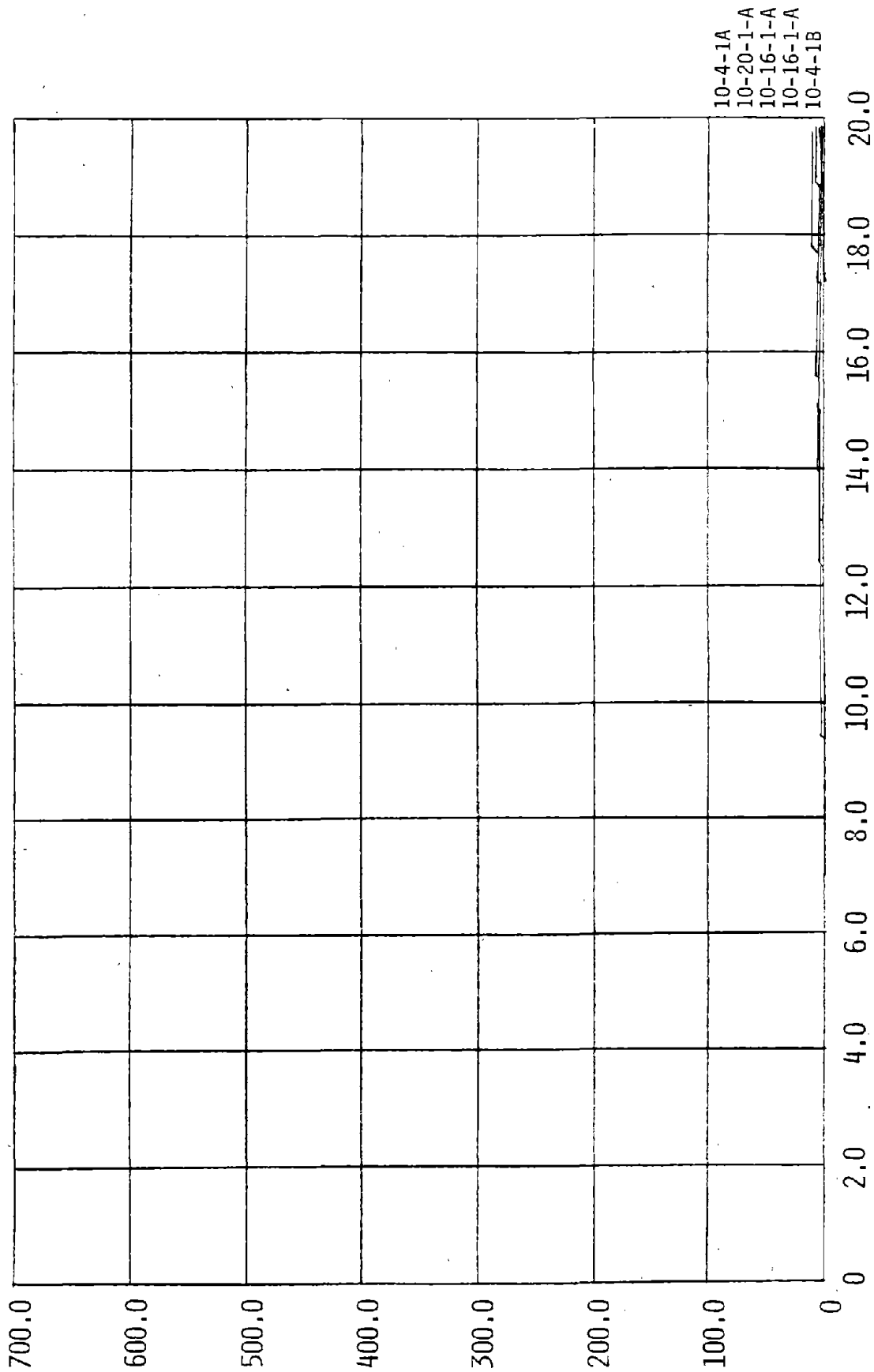

FIGURE 6-9. OPTICAL DENSITY PLOT COMPARISON (TEFLON INSULATED)

The results of the single conductor wire tests are tabulated by AWG in Table 6-14. The table is arranged in descending order of time to electrical failure for each wire size. Wires insulated with silicone rubber outperformed other insulations by far. The two next best performing insulations were mica and asbestos.

Table 6-15 shows the effect of gauge size on the time to failure. While the number of samples is too small for most of the materials, it can be postulated that gauge size can be an important criteria in the selection of wire for a high integrity circuit. The improvement in performance with the larger gauges is due to the increased general capacity of the larger gauges and the fact that in most cases the insulation wall thickness increases with gauge size. Construction also plays an important role, e.g., compare the performance of polyimide-coated Tefzel with uncoated Tefzel.

Table 6-16 presents the single conductor wire test results lumped together and averaged by materials.

6.3.2 Multiconductor Cables

Multiconductor cable test results are shown in Table 6-17, with the cables arranged according to the failure time of their first failure. Silicone rubber insulation again performed well compared to several other materials, such as Neoprene. It should be noted that 65 percent surpasses five minutes before their first failure.

Comparing the mean time to failure for multiconductor cables with the mean time to failure for single wires and taking into account the difference in the test method, it is obvious that a multiconductor jacketed cable will provide a greater degree of circuit integrity in a fire environment than a single conductor or an unjacketed cable.

From the results of both tests, it is obvious that silicone rubber jacketed cable and silicone rubber insulated wires consistently outperform all other candidate insulations/constructions.

TABLE 6-14. CIRCUIT INTEGRITY TEST RESULTS
 - SINGLE CONDUCTOR WIRE AWG 8 AND SMALLER

(Sheet 1)

SAMPLE NUMBER	INSULATION MATERIAL	TIME TO FAILURE (SECONDS)		
		MINIMUM	MAXIMUM	AVERAGE
<u>AWG 20</u>				
9-20-2	Silicone Rubber/Glass Braid	1800+	1800+	1800+
14-20-8	Silicone Rubber/Glass Braid/Terylene	875	1800	1411 ①
1-20-1	Silicone Rubber/Polyolefin	②		600
10-20-2	Kapton/Polyimide Coat	35.00	48.58	41.65
14-20-9	Kapton/Teflon(FEP)	24.09	30.42	27.62
3-20-1	Tefzel/Polyimide Coat	22.57	30.25	27.07
13-20-1	Kapton/Polyimide Coat	23.00	31.81	26.01
6-20-1	Polyolefin	24.08	27.58	25.84
11-20-1	Polyolefin	22.97	24.85	23.69
12-20-2	Teflon (TFE)	21.93	24.66	23.53
12-20-1	Teflon (EE)	21.51	24.38	23.04
10-20-1	Teflon (PTFE)	20.31	23.97	21.58
3-20-2	Kapton	16.61	25.51	19.85
14-20-7	Teflon(PTFE)	17.73	21.20	19.46
5-20-1	Tefzel	5.66	6.47	5.95
9-20-1	Polyester	4.53	4.92	4.68
14-20-4	Polyvinyl Chloride	3.83	4.36	4.16
14-20-1	Polyvinyl Chloride	3.67	4.14	3.86
14-20-2	Polyvinyl Chloride	2.83	4.19	3.72
14-20-3	Polyvinyl Chloride	3.25	4.15	3.72
14-20-5	Polyethylene	2.75	3.70	3.20
14-20-6	Polyvinyl Chloride	2.28	3.55	2.80
<u>AWG 18</u>				
10-18-3	Tefzel	7.98	9.38	8.59
<u>AWG 16</u>				
1-16-1	Silicone Rubber/Polyolefin	1800+	1800+	1800+
5-16-3	Silicone Rubber/Glass Braid	1800+	1800+	1800+
9-16-2	Silicone Rubber/Glass Braid	1800+	1800+	1800+
14-16-8	Silicone Rubber/Glass Braid/Terylene	1800+	1800+	1800+
① Wire broke to terminate all but one test.				
② Wire broke to terminate each test.				

TABLE 6-14. CONTINUED

(Sheet 2)

SAMPLE NUMBER	INSULATION MATERIAL	TIME TO FAILURE (SECONDS)		
		MINIMUM	MAXIMUM	AVERAGE
<u>AWG 16 (Cont'd.)</u>				
5-16-2	Teflon/Asbestos/Glass Braid	34.05	40.98	37.80
4-16-1	Polyvinyl Chloride	30.65	34.75	32.72
6-16-1	Polyolefin	30.50	32.76	32.12
10-16-1	Teflon (PTFE)	29.46	31.57	30.43
13-16-1	Kapton	27.50	32.16	30.43
11-16-1	Polyolefin	27.98	29.27	28.54
14-16-7	Teflon (PTFE)	25.67	27.70	26.82
12-16-3	Tefzel	9.36	10.90	9.86
10-16-3	Tefzel	8.97	9.97	9.59
9-16-1	Polyester	5.76	6.53	6.11
8-16-1	Tefzel	Not	Tested	IM
<u>AWG 14</u>				
14-14-10	Silicone Rubber	1800+	1800+	1800+
2-14-2	Mica/Glass Braid/Silicone	812	1595	1137
2-14-1	Asbestos/Teflon/Glass Braid	567	1255	896
A5-14-1	EPR/Hypalon	105	114	110
A5-14-2	EPR	91	106	100
10-14-2	Kapton/Polyimide Coat	41.5	56.0	49.7
A1-14-1	Polyvinyl Chloride	14.8	23.6	19.4
A2-14-2	Thermoplastic	7.6	10.1	9.23
A2-14-1	Thermoplastic/Nylon	5.4	6.0	5.65
<u>AWG 12</u>				
12-12-3	Tefzel	10.11	11.40	10.90
12-12-4	Halar	9.44	10.25	9.84
<u>AWG 10</u>				
12-10-3	Tefzel	12.07	13.94	12.92
IM - Insufficient material to conduct this test.				

TABLE 6-14. CONTINUED

(Sheet 3)

SAMPLE NUMBER	INSULATION MATERIAL	TIME TO FAILURE (SECONDS)		
		MINIMUM	MAXIMUM	AVERAGE
<u>AWG 8</u>				
1-8-1	Silicone Rubber/Polyolefin	1800+	1800+	1800+
9-8-2	Silicone Rubber/Glass Braid	1800+	1800+	1800+
11-8-2	Polyolefin	128	145	136
3-8-2	Kapton	102	183	127
13-8-1	Kapton/Nomex Braid	97.3	130.3	119.6
3-8-1	Tefzel/Polyimide Coat	52.6	62.2	55.8
6-8-1	Polyolefin	45.4	62.2	53.2
4-8-1	Polyvinyl Chloride	36.3	45.0	41.3
10-8-3	Tefzel	13.1	15.6	14.0
<u>AWG 6</u>				
11-6-2	Polyolefin	114	153	136

TABLE 6-15. MEAN TIME TO FAILURE VERSUS MATERIAL AND GAUGE SIZE AWG 8 AND SMALLER

INSULATION	MEAN TIME TO FAILURE (SEC)						
	AWG 20	AWG 18	AWG 16	AWG 14	AWG 12	AWG 10	AWG 8
SILICONE RUBBER *	1270	-	1800+	1800+	-	-	1800+
MICA *				1137			
ASBESTOS*				896			
EPR/HYPALON				105			
POLYOLEFIN			30				94
KAPTON	29	-	30	50			123
TEFLON/ASBESTOS		-		38			
POLYIMIDE COATED TEFLON	27						55
TEFLON (PTFE)	22		29				
TEFZEL	6	9	10		11	13	14
POLYVINYL CHLORIDE	4	-	33	19			41
POLYESTER	5		6				
POLYETHYLENE	3						

* These materials are composites.

TABLE 6-16. CIRCUIT INTEGRITY TEST SUMMARY

INSULATION	NUMBER OF SAMPLES TESTED	TIME TO FAILURE (SEC)		
		MINIMUM	MAXIMUM	AVG.
Silicone Rubber*	10	600	1800	1641
Mica	1	-	-	1137
Asbestos	1	-	-	896
EPR/Hypalon	1	-	-	110
EPR	1	-	-	100
Polyolefin	7	23.7	136	62.2
Kapton	8	19.8	127.3	55.3
Teflon/Asbestos	1	-	-	37.8
Teflon	6	19.5	30.4	24.1
Tefzel	9	5.9	55.8	17.2
Polyvinyl Chloride	9	2.8	41.3	12.4
Halar	1	-	-	9.8
Thermoplastic**	1	-	-	9.2
Thermoplastic/Nylon**	1	-	-	5.6
Polyester	2	4.7	6.1	5.4
Polyethylene	1	-	-	3.2

* Eight of the ten samples had not failed at the end of 30 minutes when testing was discontinued. One sample averaged approximately 600 seconds, but each failure was due to wire breakage with a 1 pound weight attached to the end of the wire.

** Thermoplastic is probably PVC.

TABLE 6-17. CIRCUIT INTEGRITY TEST RESULTS, MULTICONDUCTOR CABLE

SAMPLE	CONDUCTORS AWG	INSULATION MATERIAL (Basic Insulation/Jacket)	TIME TO FAILURE (SECONDS)		REMARKS
			FIRST	SECOND	
2-2x16-1	2/16	Silicone Rubber/Silicone Rubber	1800+	1800+	No failure after 1800 sec. exposure.
A6-4x12-1	4/12	Silicone Rubber/Mylar/Glass	1800+	1800+	No failure after 1800 sec. exposure.
A2-19x12-1	19/12	Tefzel/Neoprene	1800+	1800+	No failure after 1800 sec. exposure.
A3-7x14-1	7/14	EPR/Neoprene	1259	1429	First indication of failure ②
A3-7x14-2	7/14	Synthetic Rubber/Neoprene	1116	1268	
A7-24x19-5	24/19	Polyethylene/Polyvinyl Chloride	987	1112	
A5-Mx19-5	148/19	Polypropylene/Polyethylene/PVC	685	833	One sample only, extreme flammable ③
4-7x12-2	7/12	Polyethylene/Neoprene	552	746	
13-7x14-1	7/14	Mica-Teflon (FEP)/Teflon (FEP)	451	1475	④
A3-7x14-5	7/14	Polyolefin/Polyolefin	410	494	
4-7x12-1	7/12	Polyethylene/Polyethylene	364	540	Some failure indications were intermittent
13-7x14-2	7/14	Mica-Tefzel/Tefzel	309	470	Some failures were intermittent.
6-7x12-1	7/12	Polyolefin/Polyolefin	308	319	First indication of failure ⑤
13-7x12-3	7/12	Kapton/Kapton	238	280	
A7-6x19-4	6/19	Polyethylene/Polyvinyl Chloride	148	168	
A3-7x14-4	7/14	Halar/Halar	124	131	
A2-6x19-4	6/19	Polyethylene/Shield/Polyethylene	80	121	
10-3x16-1 ①	3/16	Tefzel/Shield/Tefzel	39	42	
3-7x20-1 ①	7/20	Kapton (No Jacket)	23	24	
3-7x20-1 ①	7/20	Tefzel/Polyimide (No Jacket)	21	22	

- ① The Fisher burner test is very severe on these small cables, especially those without jackets.
- ② Seven of eight failures began by the faintest glow of the failure indication lamp filament, building up to full brightness in an average time of 315 seconds. Time shown is time of first indication.
- ③ Specimen burns with furor after grease impregnant reaches flame temperature. Only one sample burned.
- ④ Some failure indications began with a faint glow of the filament and gradually increased to the full intensity of the failure indication lamp. Some samples had no second failure within 30 minutes.
- ⑤ Similar to ② except an average of 68 seconds from faint indication until full glow of failure lamp.

6.4 Results of Additional Performance Evaluation

As stated in section 5.6 it was intended that additional performance evaluation tests would be conducted on most of the samples submitted. However, some samples were of inadequate quantity to perform all the tests. The results of the conducted tests will be discussed separately in the following section.

6.4.1 Scrape Abrasion Resistance Test Results

This test was conducted in accordance with the procedures of section 5.6.1. It was found during this testing phase that the contractor's scrape test equipment could not properly be used to test wires larger than AWG 4, so sizes larger than AWG 4 were not included in these tests. Tests were performed only on single conductor wires.

A pass/fail value was more or less arbitrarily selected as 25 percent of the average of each wire size. This is a floating figure for each wire size and seems to be more appropriate than a fixed figure to cover all wire sizes. As the test results are studied, it should be noted that for AWG 4 wires, there is one sample that overshadowed its nearest competitor by a factor of over 10. In this case, the very high figure was omitted, and the average of the remaining wires was used.

Using the above criteria, twenty samples (31 percent) of the 64 samples tested failed. Of these failures, nine were insulated with silicone rubber and four of the nine had a polyolefin jacket over the silicone rubber. The next most numerous groups of failures were four insulated with Kapton, and three insulated with PVC.

The weights that were applied to the abrading blade during the tests were as follows:

AWG 20 through 14	-	3 lbs
AWG 12 through 10	-	4 lbs
AWG 8 through 6	-	6 lbs
AWG 4	-	10 lbs

The results of the tests are presented in Table 6-18, which is arranged in descending order of performance for each gauge size. Some of the better performers are highlighted in Table 6-19. A review of Table 6-18 shows the following:

1. The construction details play a significant role in the scrape abrasion resistance of wire, e.g., note the significant improvement that the terylene/glass braid imparts to the silicone rubber when compared with the effect of polyolefin or glass, and note the improved performance of polyimide coated Tefzel over uncoated Tefzel.
2. The performance of PTFE Teflon is considerably improved by the inclusion of a mineral filled layer in the construction. Compare the relative performance of 10-4-1 with 12-20-1 and 12-20-2 and 10-16-1.
3. Polyolefin appears to be the best performer overall.

Since one of the objectives of the study is to rank the performance of the materials, an attempt has to be made to rank the materials for each performance test. As can be seen from Table 6-18, construction has more effect on performance than material. However, it is possible to establish a gross ranking of the abrasion resistance based on materials using the following approach:

1. Delete from Table 6-18 those samples which owe their position on the table to construction.
2. Assign each remaining sample a ranking based on performance in each wire gauge category, i.e., first ranking sample is given a "1", second is given a "2".
3. Sum the total points for the material in each gauge size and determine the mean ranking value.
4. Sum the mean ranking values based on gauge size for each material and establish a mean value.

TABLE 6-18. SCRAPE ABRASION RESISTANCE TEST RESULTS

(Sheet 1)

SAMPLE NUMBER	INSULATION MATERIAL	SCRAPES(STROKES)	PASS/FAIL
<u>AWG 20</u>			
14-20-8	Silicone Rubber/Glass/Terylene	376	P
11-20-1	Polyolefin	210	P
6-20-1	Polyolefin	120	P
3-20-1	Tefzel/Polyimide	98	P
12-20-2	Teflon (TFE)	51	P
12-20-1	Teflon (EE)	45	P
13-20-1	Kapton/Polyimide	41	P
14-20-9	Kapton/Teflon (FEP)	33	P
10-20-1	Teflon (PTFE)	30	P
14-20-4	Polyvinyl Chloride	21	P
10-20-2	Kapton/Polyimide	18	P
3-20-2	Kapton	18	P
9-20-1	Polyester	16	P
14-20-1	Polyvinyl Chloride	15	P
5-20-1	Tefzel	14	P
1-20-1	Silicone Rubber/Polyolefin	12	F
9-20-2	Silicone Rubber/Glass	12	F
14-20-3	Polyvinyl Chloride	11	F
14-20-2	Polyvinyl Chloride	8	F
14-20-7	Teflon (PTFE)	6	F
14-20-5	Polyethylene	4	F
14-20-6	Polyvinyl Chloride	0	F
Average		52.7	
Pass/Fail Value (25% Average)		13.2	
<u>AWG 18</u>			
10-18-3	Tefzel	130	P
<u>AWG 16</u>			
14-16-8	Silicone Rubber/Glass/Terylene	734	P
12-16-3	Tefzel	206	P
11-16-1	Polyolefin	198	P
10-16-3	Tefzel	172	P
6-16-1	Polyolefin	170	P
10-16-1	Teflon (PTFE)	114	P

TABLE 6-18. CONTINUED

(Sheet 2)

SAMPLE NUMBER	INSULATION MATERIAL	SCRAPES(STROKES)	PASS/FAIL
<u>AWG 16 Cont'd</u>			
14-16-7	Teflon (PTFE)	59	P
14-16-1	Polyvinyl Chloride	52	P
9-16-1	Polyester	38	P
13-16-1	Kapton/Polyimide	32	F
1-16-1	Silicone Rubber/Polyolefin	24	F
5-16-2	Teflon/Asbestos/Glass	22	F
9-16-2	Silicone Rubber/Glass	18	F
5-16-3	Silicone Rubber/Glass	17	F
8-16-1	Tefzel	N.T.	-
Average		132.6	
Pass/Fail Value (25% Average)		33.1	
<u>AWG 14</u>			
A5-14-1	EPR/Neoprene	602	P
A5-14-2	EPR	463	P
A2-14-1	Thermoplastic/Nylon	190	P
A2-14-2	Thermoplastic	159	P
2-14-1	Asbestos/Teflon/Glass	124	P
A1-14-1	Polyvinyl Chloride	85	P
10-14-2	Kapton/Polyimide	40	F
2-14-2	Mica/Glass-Silicone	22	F
14-14-10	Silicone Rubber	10	F
Average		188	
Pass/Fail Value (25% Average)		47	
<u>AWG 12</u>			
12-12-4	Halar	166	P
12-12-3	Tefzel	161	P
<u>AWG 10</u>			
12-10-3	Tefzel	507	P
<u>AWG 8</u>			
11-8-2	Polyolefin	802	P
6-8-1	Polyolefin	352	P
10-8-3	Tefzel	232	P
3-8-1	Tefzel/Polyimide	158	P

TABLE 6-18. CONTINUED

(Sheet 3)

SAMPLE NUMBER	INSULATION MATERIAL	SCRAPES(STROKES)	PASS/FAIL
<u>AWG 8 (Cont'd)</u>			
4-8-1	Polyvinyl Chloride	150	P
13-8-1	Kapton/Nomex	49	F
9-8-2	Silicone Rubber/Glass	38	F
1-8-1	Silicone Rubber/Polyolefin	14	F
3-8-2	Kapton	12	F
Average		201	
Pass/Fail Value (25% Average)		50.2	
<u>AWG 4</u>			
10-4-1	Teflon (TFE)	2274 ①	P
6-4-1	Polyolefin	190	P
9-4-2	Silicone Rubber/Glass	50	P
13-4-1	Kapton/Nomex	36	P
1-4-1	Silicone Rubber/Polyolefin	12	F
Average ①		69.5	
Pass/Fail Value (25% Average)		17.4	
① Omitted from average N.T.- Not Tested			

TABLE 6-19. SCRAPE ABRASION RESISTANCE TEST RESULTS
Better Performers

SAMPLE NUMBER	INSULATION MATERIAL	STROKES	PERCENT OF AVERAGE
<u>AWG 20</u> (Avg. 52.7 strokes)			
14-20-8	Silicone Rubber/Glass/Terylene	376	713
11-20-1	Polyolefin	210	398
6-20-1	Polyolefin	120	228
3-20-1	Tefzel/Polyimide	98	186
<u>AWG 18</u>			
10-18-3	Tefzel	130	①
<u>AWG 16</u> (Avg. 132.6 strokes)			
14-16-8	Silicone Rubber/Glass/Terylene	734	554
12-16-3	Tefzel	206	155
11-16-1	Polyolefin	198	149
10-16-3	Tefzel	172	130
6-16-1	Polyolefin	170	128
<u>AWG 14</u> (Avg. 188 strokes)			
A5-14-1	EPR/Hypalon	602	320
A5-14-2	EPR	463	246
<u>AWG 10</u>			
12-10-3	Tefzel	507	①
<u>AWG 8</u> (Avg. 201 strokes)			
11-8-2	Polyolefin	802	399
6-8-1	Polyolefin	352	175
<u>AWG 6</u>			
11-6-2	Polyolefin	484	①
<u>AWG 4</u> (Avg. 69.5 ^② strokes)			
10-4-1	Teflon (TFE)	2274 ^②	3272
6-4-1	Polyolefin	190	273
① Only one sample tested - No average			
② Performance of 10-4-1 was not included in the average.			

5. Rank the insulation materials based on the mean value. The insulation which scores the lowest number of points is judged to have the overall best performance, and hence, the highest ranking.

Table 6-20 illustrates application of this approach to the samples delineated in Table 6-18.

The results of using the approach discussed above and arriving at the ranking of Table 6-20 is considered valid because it is indicative of the performance of the material without the aid of any improvements such as braids, topcoats, etc.

6.4.2 Insulation Resistance Test Results

Insulation resistance tests were performed according to the test procedure presented in section 5.6.2. All test results below 2500 megohms per 1000 feet were considered failures. Tabulated results are presented in Table 6-21. Of the 72 samples tested, 13 (18 percent) failed to meet the above criteria. Failures were predominantly insulated with PVC and silicone rubber.

A ranking of the performance of the materials based on the results of the insulation resistance testing is presented in Table 6-22. The method used to develop Table 6-22 was the same as that discussed in Section 6.5.1.

6.4.3 Surface Resistance Test Results

Surface resistance tests were conducted in accordance with the procedures presented in section 5.6.3 of this report. Test results are categorized by wire size and presented in Table 6-23. It should be noted that due to the nature of the test, the insulation material listed is the finish insulation. As some samples have jackets over the primary insulation material, it is the jacket material that is listed.

A minimum of five megohms-inches (diameter times resistance) was required both before and after charging to 2500 volts for one minute, without distress during the charge period, in order to pass the test.

TABLE 6-20. RANKING OF MATERIALS BASED ON SCRAPE ABRASION RESISTANCE

MATERIAL	POINTS BASED ON PERFORMANCE					RANK
	AWG 20	AWG 16	AWG 8	AWG 4	MEAN NO. OF POINTS	
Polyolefin	1.5	3	1.5	2	2.0	1
Teflon (PTFE)	4.7	5.5		1	3.7	2
Tefzel	13	1.5	3.0		5.8	3
Kapton	7.5	9	7.5	4	7.0	4
Silicone Rubber	14.5	11	7.5	4	9.3	5
PVC	16.25	7	5		9.4	6
Polyester	11	8			9.5	7
Polyethylene	19				19*	8*

* Insufficient sample range to make equitable ranking.

TABLE 6-21. INSULATION RESISTANCE TEST RESULTS

(Sheet 1)

SAMPLE NUMBER	INSULATION MATERIAL	INSULATION RESISTANCE MEGOHM PER 1000 FT.	PASS/FAIL
<u>AWG 20</u>			
10-20-1	Teflon(PTFE)	> 240 x 10 ⁶	P
14-20-7	Teflon(PTFE)	120 x 10 ⁶	P
5-20-1	Tefzel	12 x 10 ⁶	P
3-20-3	Kapton	1.2 x 10 ⁶	P
3-20-1	Tefzel	1.2 x 10 ⁶	P
12-20-1	Teflon (EE)	750 x 10 ³	P
14-20-9	Kapton	425 x 10 ³	P
9-20-1	Polyester	360 x 10 ³	P
14-20-5	Polyethylene	300 x 10 ³	P
13-20-1	Kapton	275 x 10 ³	P
6 20-1	Polyolefin	74.4 x 10 ³	P
12-20-2	Teflon (TFE)	62.5 x 10 ³	P
9-20-2	Silicone Rubber	43.2 x 10 ³	P
11-20-1	Polyolefin	30 x 10 ³	P
14-20-8	Silicone Rubber	19.5 x 10 ³	P
1-20-1	Silicone Rubber	1.08 x 10 ³	F
14-20-2	Polyvinyl Chloride	612.5	F
14-20-1	Polyvinyl Chloride	525	F
14-20-3	Polyvinyl Chloride	312.5	F
14-20-4	Polyvinyl Chloride	57.5	F
14-20-6	Polyvinyl Chloride	0.125	F
10-20-2	Kapton	N.T.	-
<u>AWG 18</u>			
10-18-3	Tefzel	> 240 x 10 ⁶	P
<u>AWG 16</u>			
10-16-1	Teflon (PTFE)	> 24 x 10 ⁶	P
10-16-3	Tefzel	> 24 x 10 ⁶	P
9-16-2	Silicone Rubber	1.18 x 10 ⁶	P
6-16-1	Polyolefin	132 x 10 ³	P
5-16-2	Teflon/Asbestos	125 x 10 ³	P
12-16-3	Tefzel	90 x 10 ³	P

TABLE 6-21. CONTINUED

(Sheet 2)

SAMPLE NUMBER	INSULATION MATERIAL	INSULATION RESISTANCE		PASS/FAIL
		MEGOHM	PER 1000 FT.	
<u>AWG 16 (Cont.)</u>				
13-16-1	Kapton	75	$\times 10^3$	P
14-16-7	Teflon (PTFE)	35	$\times 10^3$	P
11-16-1	Polyolefin	32.5	$\times 10^3$	P
9-16-1	Polyester	28.8	$\times 10^3$	P
4-16-1	Polyvinyl Chloride	16.3	$\times 10^3$	P
5-16-3	Silicone Rubber	6.0	$\times 10^3$	P
14-16-8	Silicone Rubber	1.25	$\times 10^3$	F
1-16-1	Silicone Rubber	0.96	$\times 10^3$	F
8-16-1	Tefzel	N.T.		-
<u>AWG 14</u>				
A5-14-1	EPR/Hypalon	450	$\times 10^6$	P
A5-14-2	EPR	250	$\times 10^6$	P
A1-14-1	Polyvinyl Chloride	25.8	$\times 10^6$	P
A2-14-1	Thermoplastic/Nylon	8.5	$\times 10^6$	P
A2-14-2	Thermoplastic	220	$\times 10^3$	P
2-14-1	Asbestos	48	$\times 10^3$	P
14-14-10	Silicone Rubber	42.5	$\times 10^3$	P
2-14-2	Mica	0.69		F
10-14-2	Kapton	N.T.		-
<u>AWG 12</u>				
12-12-3	Tefzel	212.5	$\times 10^3$	P
12-12-4	Halar	47.5	$\times 10^3$	P
<u>AWG 10</u>				
12-10-3	Tefzel	300	$\times 10^3$	P
<u>AWG 8</u>				
11-8-2	Polyolefin	150	$\times 10^6$	P
3-8-2	Kapton	> 24	$\times 10^6$	P
6-8-1	Polyolefin	> 24	$\times 10^6$	P
N.T. - Not Tested				

TABLE 6-21. CONTINUED.

(Sheet 3)

SAMPLE NUMBER	INSULATION MATERIAL	INSULATION RESISTANCE MEGOHM PER 1000 FT.	PASS/FAIL
<u>AWG 8 (Cont.)</u>			
3-8-1	Tefzel/Polyimide	1.44×10^6	P
4-8-1	Polyvinyl Chloride	36×10^3	P
13-8-1	Kapton	5×10^3	P
9-8-2	Silicone Rubber	2.64×10^3	P
1-8-1	Silicone Rubber	1.34×10^3	F
10-8-3	Tefzel	N.T.	-
<u>AWG 6</u>			
11-6-2	Polyolefin	130×10^6	P
<u>AWG 4</u>			
6-4-1	Polyolefin	47×10^3	P
10-4-1	Teflon (TFE)	18×10^3	P
9-4-2	Silicone Rubber	2.23×10^3	F
1-4-1	Silicone Rubber	1.13×10^3	F
13-4-1	Kapton	95	F
<u>AWG 3</u>			
10-3-3	Tefzel	18.7×10^3	P
<u>AWG 2</u>			
A7-2-1	Polyethylene	110×10^6	P
<u>AWG 2/0</u>			
A7-00-2	EPR/Neoprene	85×10^6	P
11-00-2	Polyolefin	61×10^6	P
15-00-1	Hypalon	2.6×10^6	P
6-00-1	Polyolefin	384×10^3	P
3-00-3	Kapton	40.8×10^3	P
10-00-3	Tefzel	N.T.	-
N.T. - Not Tested			

TABLE 6-21. CONTINUED

(Sheet 4)

SAMPLE NUMBER	INSULATION MATERIAL	INSULATION RESISTANCE MEGOHM PER 1000 FT.	PASS/FAIL
<u>250 MCM</u> A2-250-2	Thermoplastic	385 x 10 ³	P
<u>500 MCM</u> 10-500-4	Teflon (FEP)	675 x 10 ³	P
11-500-1	Polyolefin	67.5 x 10 ³	P
4-500-1	Polyvinyl Chloride	7.2 x 10 ³	P

TABLE 6-22. RANKING OF MATERIALS BASED ON INSULATION RESISTANCE

MATERIAL	POINTS BASED ON PERFORMANCE					RANK
	AWG 20	AWG 16	AWG 8	AWG 4	MEAN NO. OF POINTS	
Teflon	4.25	4.7		2	3.65	1
Tefzel	4	4	4		4	2
Polyolefin	12.5	6.5	2	1	5.5	3
Kapton	7	7	4	5	5.75	4
Polyester	8	10			9	5
Polyethylene	9 *				9	6 *
Silicone Rubber	14.6	14	7.5	3.5	9.9	7
PVC	18.5	11	5		11.5	8

* Insufficient sample range to make equitable ranking.

TABLE 6-23. SURFACE RESISTANCE TEST RESULTS

SAMPLE NUMBER	INSULATION MATERIAL (SURFACE) *	OUTSIDE DIAMETER (INCHES)	RESISTANCE (BEFORE-M Ω)	MEGOHM-INCHES (BEFORE)	RESISTANCE (AFTER-M Ω)	MEGOHM-INCHES (AFTER)	PASS/FAIL
AWG 20							
12-20-1	Teflon (EE)	0.068	700 x 10 ³	47.6 x 10 ³	700 x 10 ³	47.6 x 10 ³	P
10-20-2	Kapton	0.056	65 x 10 ³	3.64 x 10 ³	680 x 10 ³	38.1 x 10 ³	P
1-20-1	Polyolefin	0.103	25 x 10 ³	2.6 x 10 ³	33 x 10 ³	3.4 x 10 ³	P
10-20-1	Teflon (PTFE)	0.068	23 x 10 ³	1.6 x 10 ³	39 x 10 ³	2.7 x 10 ³	P
14-20-5	Polyethylene	0.080	22 x 10 ³	1.8 x 10 ³	27.7 x 10 ³	2.2 x 10 ³	P
9-20-1	Polyester	0.069	24 x 10 ³	1.7 x 10 ³	32 x 10 ³	2.2 x 10 ³	P
5-20-1	Tefzel	0.061	27 x 10 ³	1.6 x 10 ³	35 x 10 ³	2.1 x 10 ³	P
11-20-1	Polyolefin	0.098	21 x 10 ³	2.1 x 10 ³	21.5 x 10 ³	2.1 x 10 ³	P
14-20-1	Polyvinyl Chloride	0.083	19.7 x 10 ³	1.6 x 10 ³	25 x 10 ³	2.1 x 10 ³	P
14-20-8	Terylene	0.101	15.5 x 10 ³	1.6 x 10 ³	17.4 x 10 ³	1.8 x 10 ³	P
14-20-2	Polyvinyl Chloride	0.083	16.5 x 10 ³	1.4 x 10 ³	21 x 10 ³	1.7 x 10 ³	P
14-20-7	Teflon (PTFE)	0.061	22 x 10 ³	1.3 x 10 ³	28.4 x 10 ³	1.7 x 10 ³	P
14-20-4	Polyvinyl Chloride	0.083	16.3 x 10 ³	1.4 x 10 ³	19.6 x 10 ³	1.6 x 10 ³	P
14-20-9	Teflon (FEP)	0.055	20.7 x 10 ³	1.1 x 10 ³	25.5 x 10 ³	1.4 x 10 ³	P
14-20-3	Polyvinyl Chloride	0.084	13.2 x 10 ³	1.1 x 10 ³	15.2 x 10 ³	1.3 x 10 ³	P
3-20-1	Tefzel	0.059	18 x 10 ³	1.1 x 10 ³	21 x 10 ³	1.2 x 10 ³	P
3-20-2	Kapton	0.055	19 x 10 ³	1.0 x 10 ³	22 x 10 ³	1.2 x 10 ³	P
12-20-2	Teflon (TFE)	0.061	14.8 x 10 ³	903	15.9 x 10 ³	970	P
13-20-1	Polimide	0.054	15.8 x 10 ³	853	16.9 x 10 ³	913	P
6-20-1	Polyolefin	0.135	133	18.0	182	24.6	P
14-20-6	Polyvinyl Chloride	0.076	5.3	0.4	4.8	0.4	F
9-20-2	Glass Braid-Lacquer	0.118	12.7	1.5	22	2.6	F
AWG 18							
10-18-3	Tefzel	0.083	22 x 10 ³	1.8 x 10 ³	27.8 x 10 ³	2.3 x 10 ³	P

* This is the surface material.

TABLE 6-23. CONTINUED

SAMPLE NUMBER	INSULATION MATERIAL (SURFACE)*	OUTSIDE DIAMETER (INCHES)	RESISTANCE (BEFORE- $M\Omega$)	MEGOHM-INCHES (BEFORE)	RESISTANCE (AFTER- $M\Omega$)	MEGOHM-INCHES (AFTER)	PASS/FAIL
<u>AWG 16</u>							
8-16-1	Tefzel	0.099	630×10^3	62.4×10^3	630×10^3	62.4×10^3	P
9-16-1	Polyester	0.093	670×10^3	62.3×10^3	700×10^3	65.1×10^3	P
6-16-1	Polyolefin	0.152	22×10^3	3.3×10^3	29×10^3	4.4×10^3	P
1-16-1	Polyolefin	0.142	23×10^3	3.3×10^3	29×10^3	4.1×10^3	P
11-16-1	Polyolefin	0.113	20.5×10^3	2.3×10^3	26×10^3	2.9×10^3	P
10-16-3	Tefzel	0.094	18.5×10^3	1.7×10^3	20.7×10^3	1.9×10^3	P
10-16-1	Teflon (PTFE)	0.088	18.5×10^3	1.6×10^3	20.8×10^3	1.8×10^3	P
14-16-1	Polyvinyl Chloride	0.121	14.8×10^3	1.8×10^3	14.1×10^3	1.7×10^3	P
13-16-1	Polyimide	0.072	16.5×10^3	1.2×10^3	17.6×10^3	1.3×10^3	P
14-16-7	Teflon (PTFE)	0.081	456	60.2	610	80.5	P
14-16-8	Terylene	0.126	470	59.2	633	80.0	P
5-16-3	Glass Braid-Lacquer	0.132	390	51.5	458	60.5	P
12-16-3	Tefzel	0.094	149	14.0	205	19.3	P
9-16-2	Glass Braid-Lacquer	0.136	17.5	2.4	14.2	1.9	F
5-16-2	Glass-Braid	0.120	9.5	1.1	12.2	1.5	F
<u>AWG 14</u>							
A5-14-2	E P R	0.215	0.9×10^6	0.19×10^6	75×10^3	16×10^3	P
A1-14-1	Polyvinyl Chloride	0.102	1.4×10^6	0.14×10^6	2.8×10^6	0.29×10^6	P
A5-14-1	Hypalon	0.227	0.25×10^6	57×10^3	95×10^3	22×10^3	P
A2-14-2	Thermoplastic	0.156	0.19×10^6	30×10^3	0.2×10^3	31×10^3	P
10-14-2	Polyimide	0.086	70×10^3	6.0×10^3	655×10^3	57.2×10^3	P
2-14-1	Glass-Teflon	0.165	5.1×10^3	842	5.8×10^3	957	P
2-14-2	Glass	0.112	3×10^3	336	3.16×10^3	354	P
A2-14-1	Nylon	0.109	3.8×10^3	414	3.0×10^3	327	P
14-14-10	Silicone Rubber	0.149	416	62.0	550	82.0	P

* This is the surface material.

TABLE 6-23. CONTINUED

SAMPLE NUMBER	INSULATION MATERIAL (SURFACE) *	OUTSIDE DIAMETER (INCHES)	RESISTANCE (BEFORE-M Ω)	MEGOHM-INCHES (BEFORE)	RESISTANCE (AFTER-M Ω)	MEGOHM-INCHES (AFTER)	PASS/FAIL
<u>AWG 12</u>							
12-12-3	Tefzel	0.127	140	17.8	150	19.0	P
12-12-4	Halat	0.130	53	6.9	73.5	9.6	P
<u>AWG 10</u>							
12-10-3	Tefzel	0.159	57	9.1	79	12.6	P
<u>AWG 8</u>							
1-8-1	Polyolefin	0.294	21.5 x 10 ³	6.3 x 10 ³	29 x 10 ³	8.5 x 10 ³	P
6-8-1	Polyolefin	0.277	20.6 x 10 ³	5.7 x 10 ³	24.7 x 10 ³	6.8 x 10 ³	P
3-8-2	Kapton	0.165	30 x 10 ³	5.0 x 10 ³	41 x 10 ³	6.8 x 10 ³	P
10-8-3	Tefzel	0.197	25 x 10 ³	4.9 x 10 ³	34 x 10 ³	6.7 x 10 ³	P
3-8-1	Polyimide	0.182	26 x 10 ³	4.7 x 10 ³	36 x 10 ³	6.6 x 10 ³	P
13-8-1	Nomex Braid	0.183	19 x 10 ³	3.5 x 10 ³	23 x 10 ³	4.2 x 10 ³	P
4-8-1	Polyvinyl Chloride	0.250	5 x 10 ³	1.2 x 10 ³	5 x 10 ³	1.2 x 10 ³	P
11-8-2	Polyolefin	0.255	350	89.2	310	79.0	P
9-8-2	Glass Braid-Lacquer	0.301	1.8	0.5	3.5	1.0	F
<u>AWG 6</u>							
11-6-2	Polyolefin	0.271	70 x 10 ³	19 x 10 ³	95 x 10 ³	26 x 10 ³	P
<u>AWG 4</u>							
10-4-1	Teflon (TFE)	0.355	31 x 10 ³	11 x 10 ³	40 x 10 ³	14.2 x 10 ³	P
6-4-1	Polyolefin	0.376	23.5 x 10 ³	8.8 x 10 ³	31 x 10 ³	11.7 x 10 ³	P
1-4-1	Polyolefin	0.406	19.5 x 10 ³	7.9 x 10 ³	27 x 10 ³	10.9 x 10 ³	P
13-4-1	Nomex Braid	0.300	17 x 10 ³	5.1 x 10 ³	18 x 10 ³	5.4 x 10 ³	P
9-4-2	Glass Braid	0.413	1.3	0.5	1.5	0.6	F

* This is the surface material.

TABLE 6-23. CONTINUED

SAMPLE NUMBER	INSULATION MATERIAL (SURFACE) *	OUTSIDE DIAMETER (INCHES)	RESISTANCE (BEFORE-M Ω)	MEGOHM-INCHES (BEFORE)	RESISTANCE (AFTER-M Ω)	MEGOHM-INCHES (AFTER)	PASS/FAIL
<u>AWG 3</u> 10-3-3	Tefzel	0.364	165 x 10 ³	60 x 10 ³	155 x 10 ³	56.4 x 10 ³	P
<u>AWG 2</u> A7-2-1	Polyethylene	0.394	28 x 10 ³	11.0 x 10 ³	24 x 10 ³	9.5 x 10 ³	P
<u>AWG 2/0</u> 11-00-2	Polyolefin	0.613	1.0 x 10 ⁶	0.61 x 10 ⁶	0.51 x 10 ⁶	9.5 x 10 ⁶	P
A5-003	Polyethylene Foam	0.776	0.4 x 10 ⁶	0.31 x 10 ⁶	0.4 x 10 ⁶	0.31 x 10 ⁶	P
A7-002	Neoprene	0.628	0.4 x 10 ⁶	0.25 x 10 ⁶	0.41 x 10 ⁶	0.26 x 10 ⁶	P
15-00-1	Hypalon	0.635	0.35 x 10 ⁶	0.22 x 10 ⁶	0.23 x 10 ⁶	0.15 x 10 ⁶	P
3-00-3	Teflon (PTFE)	0.519	24.5 x 10 ³	12.7 x 10 ³	30.2 x 10 ³	15.7 x 10 ³	P
6-00-1	Polyolefin	0.605	17.3 x 10 ³	10.5 x 10 ³	19 x 10 ³	11.5 x 10 ³	P
10-00-3	Tefzel	0.576	17 x 10 ³	9.8 x 10 ³	19 x 10 ³	10.9 x 10 ³	P
<u>AWG 3/0</u> A5-000-4	Neoprene	0.854	3.5 x 10 ³	3.0 x 10 ³	3.5 x 10 ³	3.0 x 10 ³	P
<u>250 MCM</u> A2-250-2	Thermoplastic	0.762	0.2 x 10 ⁶	0.15 x 10 ⁶	0.23 x 10 ⁶	0.18 x 10 ⁶	P
<u>500 MCM</u> A4-500-1	Polyvinyl Chloride	1.295	0.36 x 10 ⁶	0.47 x 10 ⁶	0.28 x 10 ⁶	0.36 x 10 ⁶	P
10-500-4	Teflon (FEP)	1.114	19.5 x 10 ³	21.7 x 10 ³	22.6 x 10 ³	25.2 x 10 ³	P
11-500-1	Polyolefin	1.214	16.9 x 10 ³	20.5 x 10 ³	18.6 x 10 ³	22.6 x 10 ³	P

* This is the surface material.

TABLE 6-23. CONTINUED

SAMPLE NUMBER	INSULATION MATERIAL (SURFACE) *	OUTSIDE DIAMETER (INCHES)	RESISTANCE (BEFORE-MΩ)	MEGOHM-INCHES (BEFORE)	RESISTANCE (AFTER-MΩ)	MEGOHM-INCHES (AFTER)	PASS/FAIL
<u>500 MCM</u> (Cont.)							
4-500-1	Polyvinyl Chloride	1.037	200	207.4	210	217.8	P
A4-500-2	Rubber (w/o Lead)	1.123	13.4	15.0	14	15.7	P
<u>1000 MCM</u>							
A4-1000-3	Polyvinyl Chloride	1.410	200	282	210	296.1	P
<u>2000 MCM</u>							
A3-2000-3	Neoprene	2.350	340	799	200	470	P

* This is the surface material.

Six (7.2 percent) samples of the 83 tested failed to meet the five megohm-inch minimums. There was no evidence of distress in any of the samples. Samples with the highest test results are listed in Table 6-24. However, in order to establish overall ranking of the materials, Table 6-25 was prepared using the approach discussed in 6.4.1.

6.4.4 Fluid Immersion Test Results

Wire samples were selected for immersion in the fluids designated in the test procedure presented in section 5.6.4. Because of the time required to test each sample in 9 fluids, the total was limited to 19 wire samples. The basis for selecting samples to be included in the immersion tests was to get as many types (compounds) of insulation materials as possible, even though they might not be the highest ranking samples.

Gasoline and trichloroethylene were the two major failure-producing fluids. Two wire samples insulated with silicone rubber and glass braid were complete failures in these fluids. The glass braid ruptured and the rubber was forced out through the ruptures. Bare wire was visible in most cases. The percent of swelling of the insulating material was exhibited by the following samples in gasoline and trichloroethylene, respectively:

A5-14-1	EPR/Hypalon swelling	28.8% and 64.7%
A5-14-2	Thermolene swelling	22.8% and 45.3%
1-8-1	Sili. Rub./Polyolefin swelling	36.5% and 29.2%
15-00-1	Hypalon swelling	8.11% and 54%
A7-00-1	EPR/Neoprene swelling	8.6% and 43.4%

Sample 13-8-1 (Kapton/Nomex) failed the "3kV-60 second hold" after exposure to ethylene glycol and trichloroethylene. Samples reacting to trichloroethylene only by swelling were: 4-8-1 (PVC, 30.7 percent), 6-8-1 (Polyolefin, 10 percent), and 11-16-1 (Polyolefin, 8.8 percent). Sample 14-16-7, Teflon (PTFE), did not fail after exposure to any of the fluids, but the breakdown voltages were consistently low in comparison to other samples. The values were in the range of 8 to 10 kV.

TABLE 6-24. SURFACE RESISTANCE TEST RESULTS

SAMPLE NUMBER	INSULATION MATERIAL	MEGOHM-INCHES BEFORE CHARGE
11-00-2	Polyolefin	610 x 10 ³
A4-500-1	PVC	470 x 10 ³
A5-00-3 *	Polyethylene Foam	310 x 10 ³
A7-00-2	Neoprene	250 x 10 ³
15-00-1	Hypalon	220 x 10 ³
A5-14-2	EPR	190 x 10 ³
A2-250-2	Thermoplastic	150 x 10 ³
A1-14-1	PVC	140 x 10 ³
8-16-1	Tefzel	62.4 x 10 ³
9-16-1	Polyester	62.3 x 10 ³
10-3-3	Tefzel	60 x 10 ³
A5-14-1	Hypalon	57 x 10 ³
12-20-1	Teflon	47.6 x 10 ³
A2-14-2	Thermoplastic	30 x 10 ³
10-500-4	Teflon (FEP)	21.7 x 10 ³
11-500-1	Polyolefin	20.5 x 10 ³
11-6-2	Polyolefin	19 x 10 ³

* Semi-conductive jacket was removed to test the foam.

TABLE 6-25. RANKING OF MATERIALS BASED ON SURFACE RESISTANCE

MATERIAL	POINTS BASED ON PERFORMANCE					RANK
	AWG 20	AWG 16	AWG 8	AWG 4	MEAN NO. OF POINTS	
Polyester	6	2	-	-	4	1
Polyolefin	9.6	4	3.3	2.5	4.85	2
Polyethylene	5*	-	-	-	5	3*
Kapton	9	-	3	-	6	4
Teflon	9.2	8.0	-	1	6.06	4
Tefzel	11	5.6	4	-	6.86	6
PVC	12.8	8	6	-	8.93	7
Silicone Rubber	-	-	-	-	-	-

* Insufficient sample range to make equitable ranking.

The performance of the remaining fluid/wire combinations were acceptable, and individual results are presented in Tables 6-26, 6-27, and 6-28. It should be noted that where an "A" appears on Table 6-28, the specimen's insulation did not fail during the dielectric test, but the test voltage arced across the insulating material from the bare conductor to the sodium chloride water bath.

6.4.5 Dielectric Strength Test Results

Dielectric tests were performed in accordance with the test procedure presented in section 5.6.5. There was a deviation in the dielectric withstand voltage value used on some samples. The value is set equal to two times the voltage rating of the test specimen plus one thousand volts. Samples of a voltage rating of 1000 volts were requested of the manufacturers, but not all samples were rated at that figure. Many were rated at 600 volts and more than one at 2000 volts. The initial tests were conducted at 2.2 kV on all 600 volt samples, but it was later decided to use 3 kV on all (remaining) samples. This was primarily due to a couple of manufacturers who, when asked the rating of some of their samples, indicated that some were actually rated for 600 volts but could be up rated to 1000 volts without concern.

The criteria for passing this test are that the specimen must not fail the withstand voltage for 1 minute nor break down below 10 kV. It is difficult to make a fair evaluation of the materials used for insulation, especially in the larger wires, because there are large variations of thickness of the material and different combinations of more than one material. A comparison is attempted only for those wires AWG 4 and smaller in Table 6-29. Those wires with more than one insulation were not included.

The actual test performance of all samples tested is categorized by wire size and presented in Table 6-30. Nine (13 percent) of the 71 samples tested failed by the 10 kV criterion. Of this number, one sample apparently failed at the very end of the withstand test as no failure was indicated in this test, but a failure was observed as soon as the minimum breakdown voltage was applied. An "A" in the table indicates that the sample did not actually fail, but the applied voltage potential arced from the bare conductor over the outside of the insulation to the conductive water bath.

TABLE 6-26. FLUID IMMERSION TEST RESULTS — DIELECTRIC TEST 3KV - 60 SECOND HOLD

WIRE FLUID SAMPLE	DIESEL FUEL NO. 2	ETHYLENE GLYCOL	GASOLINE	ISOPROPYL ALCOHOL	TRICHLORO- ETHYLENE	CLEANER DU BOIS C-1102	SEA WATER	SEWAGE	LUB.OIL (SAE 10)
5-16-3	Pass	Pass	Fail ①	Pass	Fail ①	Pass	Pass	Pass	Pass
10-16-3	Pass	Pass	Pass	Pass	Pass	Pass	Pass	Pass	Pass
11-16-1	Pass	Pass	Pass	Pass	Pass	Pass	Pass	Pass	Pass
14-16-7	Pass	Pass	Pass	Pass	Pass	Pass	Pass	Pass	Pass
A1-14-1	Pass	Pass	Pass	Pass	Pass	Pass	Pass	Pass	Pass
A2-14-1	Pass	Pass	Pass	Pass	Pass	Pass	Pass	Pass	Pass
A2-14-2	Pass	Pass	Pass	Pass	Pass ②	Pass	Pass	Pass	Pass
A5-14-1	Pass	Pass	Pass	Pass	Pass ②	Pass	Pass	Pass	Pass
A5-14-2	Pass	Pass	Pass	Pass	Pass ②	Pass	Pass	Pass	Pass
12-12-4	Pass ③	Pass	Pass ③	Pass	Pass	Pass	Pass	Pass	Pass
1-8-1	Pass	Pass	Pass	Pass	Pass	Pass	Pass	Pass	Pass
3-8-2	Pass	Pass	Pass	Pass	Pass	Pass	Pass	Pass	Pass
4-8-1	Pass	Pass	Pass	Pass	Pass	Pass	Pass	Pass	Pass
6-8-1	Pass	Pass	Pass	Pass	Pass	Pass	Pass	Pass	Pass
9-8-2	Pass	Pass	Fail ①	Pass	Fail ①	Pass	Pass	Pass	Pass
13-8-1	Pass	Fail	Pass	Pass	Fail	Pass	Pass	Pass	Pass
3-00-3	Pass	Pass	Pass	Pass	Pass	Pass	Pass	Pass	Pass
15-00-1	Pass	Pass	Pass	Pass	Pass	Pass	Pass	Pass	Pass
A7-00-1	Pass	Pass	Pass	Pass	Pass	Pass	Pass	Pass	Pass

① The silicone rubber broke through the glass braid.

② The insulation absorbed fluid until it wicked up the inside and came out the end of wire.

③ Following immersion, cracks appear inside the insulation (it is transparent).

TABLE 6-27. FLUID IMMERSION TEST RESULTS -- SWELLING OF INSULATION MATERIAL (O.D. CHANGE %)

WIRE FLUID SAMPLE	DIESEL FUEL NO. 2	ETHYLENE GLYCOL	GASOLINE	ISOPROPYL ALCOHOL	TRICHLORO-ETHYLENE	CLEAHER DU BGIS C-1102	SEAWATER	SEWAGE	LUB. OIL (SAE 10)
5-16-3	-0.2	-2.7	①	-5.2	①	-0.9	-2.9	-1.4	<0.1
10-16-3	-0.7	-0.3	-0.2	-0.7	-1.2	1.0	-0.3	-0.5	-1.0
11-16-1	1.2	0.4	6.6	0.7	8.8	-0.5	0.5	<0.1	0.2
14-16-7	0.1	0.1	0.2	0.2	0.2	0.6	0.6	0.2	0.4
A1-14-1	-1.1	-0.3	0.5	-0.5	-2.6	0	-0.9	-0.6	-1.3
A2-14-1	-1.8	-1.6	-2.8	-2.4	-1.5	-2.3	-2.8	-2.7	-1.3
A2-14-2	1.0	0.6	-3.8	-2.8	3.7	0.7	0.4	0.6	0
A5-14-1	-0.7	-1.9	28.8	-1.0	64.7	-1.6	1.2	-1.8	-2.2
A5-14-2	-3.1	-3.2	22.8	-4.4	45.3	-2.8	-2.0	-3.3	-3.2
12-12-4	0.6	0.2	0.8	0.8	0.7	-0.5	0.5	0.5	-0.1
1-8-1	1.1	-0.7	36.5	2.0	29.1	-2.2	-1.7	-1.6	-1.3
3-8-2	0.6	<0.1	0.4	0.6	0.4	0.4	0.3	0.5	0.4
4-8-1	-0.7	-1.3	3.4	-0.3	30.7	-0.5	-1.0	-0.4	-0.4
6-8-1	-0.7	-0.5	1.9	-0.8	10.0	-1.3	-0.8	1.7	-0.5
9-8-2	-2.5	0	2.4	-0.2	1.8	2.4	0.3	0.8	3.6
13-8-1	0.5	0.3	1.4	2.4	3.0	0.4	1.4	0.8	0
3-00-3	1.7	0.6	0.3	2.1	2.2	-0.4	1.2	1.4	0.6
15-00-1	-0.2	-0.5	8.1	-1.1	54.0	-0.8	-1.2	-0.8	-1.4
A7-00-1	2.3	0.4	8.6	-0.4	43.4	0.3	0.4	0.2	0.2

① The outer glass braid ruptured and the silicone rubber was extruded through the rupture. Bare wire was visible in most cases.

TALBE TABLE 6-28. FLUID IMMERSION TEST RESULTS - DIELECTRIC BREAKDOWN (KV)

WIRE FLUID SAMPLE	DIESEL FUEL NO. 2	ETHYLENE GLYCOL	GASOLINE	ISOPROPYL ALCOHOL	TRICHLORO-ETHYLENE	CLEANER DU ECIS C-1102	SEAWATER	SEWAGE	LUB. OIL (SAE 10)
5-16-3	22	12.5	①	12.5	①	10	13A	11.5	13
10-16-3	25A	20A	35A	25A	35A	25A	23A	23A	28A
11-16-1	23A	22A	25A	23	24A	25	18	26A	24
14-16-7	10	9.5	10	9	9	9	9	9.5	8
A1-14-1	24	15.5	31	19	17.5	18.5	15.5	22.5	21.5
A2-14-1	21	22	20	21	22	26	26	23	19.5
A2-14-2	40	29	38	30	25	40	35	43	36
A5-14-1	26	24	38	30	> 50 ②	27	28	22	30.5
A5-14-2	32	5 ③	38	34	43A	34	39	36	32
12-12-4	25A	19.5	25A	12	23A	24A	23A	37A	30A
1-8-1	24A	24A	21	17A	23A	25A	25	23	24
3-8-2	13	15A	12.5	17	13A	13	15	12.5A	12
4-8-1	24A	23A	24A	22A	23A	22.5A	20A	30A	22A
6-8-1	25A	28A	25A	30A	30A	24	25A	30A	28A
9-8-2	23A	15	①	14A	13A ④	24A	13A	14A	48
13-8-1	12	2A	25	15A	500volts	13A	12A	12A	13A
3-00-3	17	16	18	17	17.5	15	16.5	16.5	18
15-00-1	25A	20A	24A	24A	20A	24A	23A	30A	21A
A7-00-1	39	48	45A	> 50 ②	> 50 ②	45	> 50 ②	> 50 ②	48

A Indicates that voltage potential arced over insulation to sodium chloride bath. The insulation did not break down.

① The wire was exposed - Break down voltage was zero.

② 50 kv is the maximum capability of voltage generator - specimen did not fail.

③ The specimen failed at 5 kv - Repeated applications upheld 1.5 kv.

④ Though glass braid was ruptured and rubber extruded through rupture, specimen did not fail at 13 kv (arced to bath).

TABLE 6-29. DIELECTRIC STRENGTH TEST RESULTS SUMMARY

INSULATION MATERIAL	NUMBER OF SAMPLES INCLUDED	AVERAGE BREAKDOWN (KV)	RANK
Thermoplastic	1*	29.0	1*
Polyolefin	8	20.8	2
Polyvinyl Chloride	7	20.3	3
Polyethylene	2	17.0	4
Tefzel	8	19.1	5
EPR	1*	18.0	6*
Polyester	2	16.2	7
Teflon	6	13.9	8
Silicone Rubber	6	12.9	9
Kapton	6	12.4	10
Halar	1*	12.0	11*

* Ranking determined from results of one sample.

TABLE 6-30. DIELECTRIC STRENGTH TEST RESULTS

(Sheet 1)

SAMPLE NUMBER	INSULATION	WITH-STAND (KV)	BREAKDOWN (KV)	PASS/FAIL	SAMPLE NUMBER	INSULATION	WITH-STAND (KV)	BREAKDOWN (KV)	PASS/FAIL
AWG 20									
12-20-1	Teflon (EE)	3.0	36.5	P	4-16-1	Polyvinyl Chloride	3.0	15.0	P
14-20-2	Polyvinyl Chloride	3.0	24.5A	P	5-16-3	Silicone Rubber	3.0	13.0	P
14-20-4	PVC	3.0	24.5A	P	1-16-1	Silicone Rubber	2.2	12.0	P
14-20-1	PVC	3.0	22.0A	P	10-16-1	Teflon (PTFE)	3.0	9.1	F
6-20-1	Polyolefin	2.2	22.0	P	5-16-2	Teflon/Asbestos	2.2	8.0	F
11-20-1	Polyolefin	3.0	20.5A	P	14-16-7	Teflon (PTFE)	3.0	7.5	F
14-20-5	Polyethylene	3.0	20.0A	P	8-16-1	Tefzel	N.T.	N.T.	-
14-20-3	PVC	3.0	19.5	P	AWG 14				
5-20-1	Tefzel	2.2	17.0	P	A2-14-2	Thermoplastic	3.0	29.0	P
3-20-1	Tefzel/Polyimide	2.2	16.5	P	A5-14-1	EPR/Hypalon	3.0	24.0	P
13-20-1	Kapton	3.0	15.0A	P	A2-14-1	Thermoplastic/Nylon	3.0	22.0	P
12-20-2	Teflon (TFE)	3.0	15.0	P	A1-14-1	Polyvinyl Chloride	3.0	20.0	P
3-20-2	Kapton	2.2	14.5	P	A5-14-2	EPR	3.0	18.0	P
14-20-9	Kapton/Teflon	3.0	14.0A	P	14-14-10	Silicone Rubber	3.0	13.5	P
9-20-1	Polyester	2.2	14.0	P	2-14-1	Asbestos	2.2	7.8	F
14-20-8	Silicone Rubber	3.0	14.0	P	2-14-2	Mica	2.2	0	F
1-20-1	Silicone Rubber	2.2	12.0	P	10-14-2	Kapton/Polyimide	N.T.	N.T.	F
14-20-6	Polyvinyl Chloride	3.0	11.0	P	AWG 12				
10-20-1	Teflon (PTFE)	3.0	8.4	F	12-12-3	Tefzel	3.0	17.5A	P
14-20-1	Teflon (PTFE)	3.0	7.0	F	12-12-4	Halar	3.0	12.0A	P
9-20-2	Silicone Rubber	2.2	6.0	F	AWG 10				
10-20-2	Kapton	N.T.	N.T.	-	12-10-3	Tefzel	3.0	21.5	P
AWG 18					AWG 8				
10-18-3	Tefzel	3.0	19.5	P	11-8-2	Polyolefin	3.0	23.0	P
AWG 16					4-8-1	Polyvinyl Chloride	3.0	20.6	P
6-16-1	Polyolefin	2.2	29.0	P	6-8-1	Polyolefin	2.2	20.0	P
12-16-3	Tefzel	3.0	25.0A	P	13-8-1	Kapton	3.0	16.6A	P
10-16-3	Tefzel	3.0	22.0	P	9-8-2	Silicone Rubber	2.2	16.5	P
11-16-1	Polyolefin	3.0	19.5A	P	3-8-1	Tefzel	2.2	13.5	P
9-16-1	Polyester	2.2	18.5	P	1-8-1	Silicone Rubber	2.2	13.0	P
9-16-2	Silicone Rubber	2.2	17.5	P	3-8-2	Kapton	2.2	5.6	F
14-16-8	Silicone Rubber	3.0	16.0	P	10-8-3	Tefzel	N.T.	N.T.	-
13-16-1	Kapton	3.0	15.0A	P					

"A" Signifies that the specimen did not fail, but "arced over" the insulation to the water bath.

N.T. - Not Tested

TABLE 6-30. CONTINUED

(Sheet 2)

SAMPLE NUMBER	INSULATION	WITH-STAND (kV)	BREAKDOWN (kV)	PASS/FAIL	SAMPLE NUMBER	INSULATION	WITH-STAND (kV)	BREAKDOWN (kV)	PASS/FAIL
AWG 6									
11-6-2	Polyolefin	3.0	14.0	P					
AWG 4									
13-4-1	Kapton	3.0	23.0	P					
1-4-1	Silicone Rubber	3.0	19.5	P					
6-4-1	Polyolefin	2.2	18.0	P					
9-4-2	Silicone Rubber	2.2	11.0	P					
10-4-1	Teflon (TEE)	N.T.	N.T.	-					
AWG 3									
10-3-3	Tefzel	3.0	17.5A	P					
AWG 2									
A7-2-1	Polyethylene	3.0	14.0	P					
AWG 2/0									
A7-00-2	EPR/Neoprene	3.0	28.0	P					
11-00-2	Polyolefin	3.0	25.0A	P					
15-00-1	Hypalon	3.0	19.5A	P					
6-00-1	Polyolefin	2.2	19.0	P					
3-00-3	Kapton/+Tapes	2.2	10.0	P					
10-00-3	Tefzel	N.T.	N.T.	-					
AWG 3/0									
A5-000-4	Synthetic Rubber/Neoprene	N.T.	N.T.	-					
250 MCM									
A2-250-2	Thermoplastic	3.0	21.5A	P					
500 MCM									
10-500-4	Teflon (FEP)	3.0	25.0A	P					
4-500-1	Polyvinyl Chloride	3.0	21.5	P					
11-500-1	Polyolefin	3.0	16.5A	P					
A4-500-1	EPR/PVC	N.T.	N.T.	-					
A4-500-2	Rubber/Lead	N.T.	N.T.	-					
1000 MCM									
A4-1000-3	Polyvinyl Chloride	N.T.	N.T.	-					
2000 MCM									
A3-2000-3	Synthetic Rubber/Neoprene	N.T.	N.T.	-					

6.4.6 Dynamic Cut-Through Test Results

The test was performed in accordance with the test procedure presented in section 5.6.6. The results are presented in Table 6-31 and are categorized by wire sizes. Tests were performed only on single conductor wires. A minimum acceptable value of 25 percent of the average of each wire size was more or less arbitrarily selected as the pass criterion for this test.

It should be noted that failure in this test takes place only when all of the elements in the total insulation covering have been severed. Two samples which use silicone rubber as the primary insulation performed extremely well, but they also had a fiberglass braid and jacket of Terylene over the silicone rubber.

Of the 82 samples tested, 5 (6 percent) failed to meet the minimum acceptable value. Three of those that failed were Teflon (PTFE). Materials which performed well were silicone rubber when jacketed with a fiberglass braid, some of the Kaptons, Tefzels, polyolefins, asbestos, and mica.

Table 6-32 attempts to rank the materials using the same approach used earlier in this section. It should be noted that silicone rubber is not ranked because of the necessity for the glass braid to perform a protective barrier. Silicone rubber by itself would be ranked low in this test. Again, this serves to point out the importance of construction details in addition to the basic insulation material when selecting a wire or cable for a particular application.

6.4.7 Cold Bend Test Results

The single conductor wire samples were tested in accordance with the test procedures presented in section 5.6.7 of this report. Insufficient quantities of wire samples 10-20-2, 10-14-2, 8-16-1, 10-8-3, and 10-00-3 prevented them from being included in this test. Three other samples were not included in the tests because their physical size and rigidity made them impractical to test. These samples were A3-2000-3, A4-500-2, and A7-Coax-3. No cracking was visible in the insulation of any of the specimens tested when observed under magnification.

TABLE 6-31. DYNAMIC CUT-THROUGH RESULTS

SAMPLE NUMBER	INSULATION MATERIAL	CUT-THROUGH (POUNDS)	PASS/FAIL	SAMPLE NUMBER	INSULATION MATERIAL	CUT-THROUGH (POUNDS)	PASS/FAIL
AWG 20				12-16-3	Tefzel	82	P
14-20-8	Silicone Rubber	177	P	6-16-1	Polyolefin	77	P
9-20-2	Silicone Rubber	103	P	4-16-1	Polyvinyl Chloride	46.5	P
10-20-2	Kapton	94	P	11-16-1	Polyolefin	46.3	P
6-20-1	Polyolefin	90	P	1-16-1	Silicone Rubber	43.3	P
14-20-9	Kapton	88	P	10-16-1	Teflon (PTFE)	17.0	F
9-20-1	Polyester	84	P	14-16-7	Teflon (PTFE)	16.2	F
3-20-2	Kapton	68	P		Average	87.4	
11-20-1	Polyolefin	60	P	P/F Value	-.25 x Average	21.8	
5-20-1	Tefzel	54	P				
3-20-1	Tefzel	47.3	P	AWG 14			
1-20-1	Silicone Rubber	38.3	P	2-14-1	Asbestos	428	P
13-20-1	Kapton	37.7	P	2-14-2	Mica	375	P
14-20-1	Polyvinyl Chloride	27.2	P	10-14-2	Kapton	191	P
12-20-2	Teflon (TFE)	24.2	P	A5-14-2	EPR	66	P
14-20-4	Polyvinyl Chloride	23.0	P	A2-14-2	Thermoplastic	56	P
14-20-3	Polyvinyl Chloride	18.8	P	A5-14-1	EPR/Hypalon	50	P
12-20-1	Teflon (EE)	18.0	P	A1-14-1	Polyvinyl Chloride	48	P
14-20-2	Polyvinyl Chloride	14.3	P	A2-14-1	Thermoplastic/Nylon	33	P
10-20-1	Teflon (PTFE)	13.8	P		Average ^①	64.6	F
14-20-5	Polyethylene	12.9	P	P/F Value	-.25 x Average	16.1	
14-20-7	Teflon (PTFE)	11.6	F	AWG 12			
14-20-6	Polyvinyl Chloride	9.3	F	12-12-4	Halar	84	P
	Average	50.7		12-12-3	Tefzel	59	P
P/F Value	-.25 x Average	12.7					
AWG 18				AWG 10			
10-18-3	Tefzel	57	P	12-10-3	Tefzel	79	P
AWG 16							
14-16-8	Silicone Rubber	200	P	AWG 8			
10-16-3	Tefzel	127	P	3-8-1	Tefzel	293	P
9-16-2	Silicone Rubber	122	P	9-8-2	Silicone Rubber	273	P
13-16-1	Kapton	121	P	11-8-1	Polyolefin	208	P
8-16-1	Tefzel	113	P	13-8-1	Kapton	192	P
5-16-2	Teflon/Asbestos	107	P	6-8-1	Polyolefin	178	P
9-16-1	Polyester	101	P	4-8-1	Polyvinyl Chloride	165	P
5-16-3	Silicone Rubber	91	P	1-8-1	Silicone Rubber	155	P
① Excluding the two High Values							

TABLE 6-31. CONTINUED

SAMPLE NUMBER	INSULATION MATERIAL	CUT-THROUGH (POUNDS)	PASS/FAIL	SAMPLE NUMBER	INSULATION MATERIAL	CUT-THROUGH (POUNDS)	PASS/FAIL
AWG 8 (Cont.)				AWG 3/0			
10-8-3	Tefzel	153	P	A5-000-4	Butyl Rubber/Neoprene	358	P
3-8-2	Kapton	84	P	250 MCM			
	Average	189		A2-250-2	Thermoplastic	328	P
	P/F Value - .25 x Average	47.2		500 MCM			
AWG 6				4-500-1	Polyvinyl Chloride	< 1000	P
11-6-2	Polyolefin	126	P	11-500-1	Polyolefin	< 1000	P
AWG 4				10-500-4	Teflon (FEP)	700	P
9-4-2	Silicone Rubber	380	P	A4-500-1	EPR/PVC	481	P
13-4-1	Kapton	183	P	A4-500-2	Rubber/Lead	185	P
1-4-1	Silicone Rubber	168	P				
6-4-1	Polyolefin	155	P				
10-4-1	Teflon (TFE)	107	P				
	Average	199		1000 MCM			
	P/F Value - .25 x Average	50		A4-1000-3	Polyvinyl Chloride	542	P
AWG 3				2000 MCM			
10-3-3	Tefzel	288	P	A3-2000-3	Synthetic Rubber/Neoprene	594	P
AWG 2							
A7-2-1	Polyethylene	145.5	P				
AWG 2/0							
10-00-3	Tefzel	972	P				
11-00-2	Polyolefin	605	P				
15-00-1	Hypalon	284	P				
A5-00-3	Polyethylene	270	P				
3-00-3	Kapton/+Tape	237	P				
6-00-1	Polyolefin	213	P				
A7-00-2	EPR/Neoprene	69	F				
	Average	379					
	P/F Value - .25 x Average	95					

TABLE 6-32. RANKING OF MATERIAL BASED ON DYNAMIC CUT-THROUGH TEST

MATERIAL	POINTS BASED ON PERFORMANCE					RANK
	AWG 20	AWG 16	AWG 8	AWG 4	MEAN NO. OF POINTS	
Silicone Rubber ①	4.6	5.75	4.5	1.5	4.1	
Kapton	6.7	4	6.5	2	4.8	1
Polyolefin	6	10	4	4	6	2
Polyester	6	6			6	3
Tefzel	9.5	5	4.5		6.3	4
PVC	16	10	6		10.7	5
Teflon	17.7	11		5	11.23	6
Polyethylene	20 ②				20	7

① Silicone Rubber and Fiberglass Jacket. Silicone Rubber requires some kind of protective jacket.
 ② Ranking determined from results of one sample.

6.5 Dimensional Measurements

Dimensional measurements were made on all samples received. The information was not collected to determine the quality of the product furnished but simply to provide information such as wall thickness, wire diameter, etc. This information is presented in Tables 6-33 and 6-34.

TABLE 6-33. DIMENSIONAL MEASUREMENTS, SINGLE CONDUCTOR WIRES (Sheet 1)

SAMPLE NUMBER	INSULATION MATERIAL	O. D. (IN)	WIRE DIA. (IN)	CALC. WALL (IN)
<u>AWG 20</u>				
1-20-1	Silicone Rubber	0.103	0.031	0.036
3-20-1	Tefzel	0.059	0.034	0.012
3-20-2	Kapton	0.055	0.034	0.010
5-20-1	Tefzel	0.061	0.038	0.011
6-20-1	Polyolefin	0.135	0.034	0.050
9-20-1	Polyester	0.069	0.039	0.015
9-20-2	Silicone Rubber	0.118	0.038	0.040
10-20-1	Teflon (PTFE)	0.068	0.036	0.016
10-20-2	Kapton	0.056	0.039	0.008
11-20-1	Polyolefin	0.098	0.040	0.029
12-20-1	Teflon (EE)	0.068	0.038	0.015
12-20-2	Teflon (TFE)	0.061	0.038	0.012
13-20-1	Kapton	0.054	0.037	0.008
14-20-1	Polyvinyl Chloride	0.083	0.032	0.025
14-20-2	Polyvinyl Chloride	0.083	0.032	0.025
14-20-3	Polyvinyl Chloride	0.084	0.032	0.026
14-20-4	Polyvinyl Chloride	0.083	0.032	0.026
14-20-5	Polyethylene	0.080	0.034	0.023
14-20-6	Polyvinyl Chloride	0.076	0.032	0.022
14-20-7	Teflon (PTFE)	0.061	0.038	0.012
14-20-8	Silicone Rubber	0.101	0.038	0.031
14-20-9	Kapton	0.055	0.040	0.008
<u>AWG 18</u>				
10-18-3	Tefzel	0.083	0.046	0.018
<u>AWG 16</u>				
1-16-1	Silicone Rubber	0.142	0.052	0.045
4-16-1	Polyvinyl Chloride	0.121	0.058	0.031
5-16-2	Teflon/Asbestos	0.120	0.058	0.031
5-16-3	Silicone Rubber	0.132	0.054	0.039
6-16-1	Polyolefin	0.152	0.059	0.046
8-16-1	Tefzel	0.099	0.056	0.022
9-16-1	Polyester	0.093	0.054	0.019
9-16-2	Silicone Rubber	0.136	0.055	0.041
10-16-1	Teflon (PTFE)	0.088	0.055	0.017
10-16-3	Tefzel	0.094	0.053	0.020
11-16-1	Polyolefin	0.113	0.054	0.030
12-16-3	Tefzel	0.094	0.055	0.019
13-16-1	Kapton	0.072	0.056	0.008
14-16-7	Teflon (PTFE)	0.081	0.055	0.013
14-16-8	Silicone Rubber	0.126	0.050	0.038
<u>AWG 14</u>				
2-14-1	Asbestos	0.165	0.070	0.048
2-14-2	Mica	0.112	0.071	0.020
10-14-2	Kapton	0.086	0.068	0.009
14-14-10	Silicone Rubber	0.149	0.075	0.037
A1-14-1	Polyvinyl Chloride	0.102	0.069	0.016
A2-14-1	Thermoplastic/Nylon	0.109	0.065	{ 0.0065 0.0165
A2-14-2	Thermoplastic	0.156	0.063	0.046
A5-14-1	EPR/Hypalon	0.227	0.070	0.078
A5-14-2	EPR	0.215	0.074	0.070

TABLE 6-33. CONTINUED

(Sheet 2)

SAMPLE NUMBER	INSULATION MATERIAL	O. D. (IN)	WIRE DIA. (IN)	CALC. WALL (IN)
<u>AWG 12</u>				
12-12-3	Tefzel	0.127	0.086	0.020
12-12-4	Halar	0.130	0.088	0.021
<u>AWG 10</u>				
12-10-3	Tefzel	0.159	0.111	0.024
<u>AWG 8</u>				
1-8-1	Silicone Rubber	0.294	0.165	0.064
3-8-1	Tefzel	0.182	0.150	0.016
3-8-2	Kapton	0.165	0.153	0.004
4-8-1	Polyvinyl Chloride	0.250	0.138	0.056
6-8-1	Polyolefin	0.277	0.143	0.067
9-8-2	Silicone Rubber	0.301	0.162	0.070
10-8-3	Tefzel	0.197	0.146	0.025
11-8-2	Polyolefin	0.255	0.137	0.059
13-8-1	Kapton	0.183	0.146	0.018
<u>AWG 6</u>				
11-6-2	Polyolefin	0.277	0.195	0.041
<u>AWG 4</u>				
1-4-1	Silicone Rubber	0.406	0.264	0.071
6-4-1	Polyolefin	0.376	0.256	0.060
9-4-2	Silicone Rubber	0.413	0.256	0.074
10-4-1	Teflon (TFE)	0.355	0.260	0.048
13-4-1	Kapton	0.300	0.258	0.021
<u>AWG 3</u>				
10-3-3	Tefzel	0.364	0.292	0.036
<u>AWG 2</u>				
A7-2-1	Polyethylene	0.394	0.285	0.055
<u>AWG 2/0</u>				
3-00-3	Kapton/Tapes	0.519	0.452	0.033
6-00-1	Polyolefin	0.605	0.460	0.073
10-00-3	Tefzel	0.576	0.462	0.057
11-00-2	Polyolefin	0.613	0.470	0.086
15-00-1	Hypalon	0.635	0.430	0.100
	Paper Tape			0.0025
A5-00-3	Polyethylene/Polyethylene Jacket	0.874	0.386	0.193
				0.051
A7-00-2	EPR/Neoprene	0.628	0.429	0.100
<u>AWG 3/0</u>				
A5-000-4	Butyl Rubber/Neoprene Film Jacket.	0.818	0.482	0.072
				0.002
				0.094
<u>MCM</u>				
A2-250-2	Thermoplastic	0.762	0.571	0.096
4-500-1	Polyvinyl Chloride	1.037	0.843	0.097
10-500-4	Teflon (FEP)	1.114	0.942	0.0086
11-500-1	Polyolefin	1.214	0.932	0.141
A4-500-1	Synthetic Rubber/PVC Tape Jacket	1.295	0.813	0.134
				0.010
				0.097
A4-500-2	Synthetic Rubber/Lead	1.326	0.810	0.156
A4-1000-3	Polyvinyl Chloride (0.101)	1.410	1.158	0.126
A3-2000-3	Synthetic Rubber/Neoprene Tape Jacket	2.350	1.644	0.206
				0.010
				0.137

TABLE 6-34. DIMENSIONAL MEASUREMENTS, MULTICONDUCTOR CABLES

(Sheet 1)

SAMPLE NUMBER	CONDUCTORS AWG	CABLE JACKET		INDIVIDUAL CONDUCTORS				
		O.D. (IN)	MATERIAL	WALL THICKNESS (IN)	O.D. (IN)	WIRE DIAMETER (IN)	INSULATION	WALL THICKNESS (IN)
2-2x16-1	2/16	0.274	Silicone Rubber	0.039	0.092	0.051	Silicone Rubber (black)	0.020
3-7x20-1	7/20	0.176	No Jacket	-	0.086	0.051	Silicone Rubber (white)	0.017
3-7x20-2	7/20	0.168	No Jacket	-	0.060	0.039	Tefzel/H-Coat	0.010
4-7x12-1	7/12	0.629	Polyethylene	0.065	0.056	0.040	Kapton	0.008
4-7x12-2	7/12	0.650	Paper	0.006	0.158	0.092	Polyethylene	0.033
6-7x12-1	7/12	0.546	Neoprene	0.085	0.155	0.091	Polyethylene	0.032
12-3x16-1	3/16	0.277	Mylar Film	0.003	0.153	0.087	Polyolefin	0.033
13-7x14-1	7/14	0.420	Polyolefin	0.058	0.100	0.054	Green & Yellow Tefzel	0.023
13-7x14-2	7/14	0.418	Paper & Film	0.004	0.092	0.054	Red Tefzel	0.019
13-7x12-3	7/12	0.335	Tefzel	.022 to .035	0.116	0.068	Teflon (FEP)	0.016
A2-19x12-3	19/12	0.936	Shield Film	0.012	0.114	0.068	Mica	0.008
A2-6/2x19-4	12/19	0.578x 1.080	Teflon (FEP)	0.040	0.109	0.088	Tefzel	0.014
A3-7x14-1	7/14	0.988	Tefzel	0.044	0.140	0.120	Mica	0.009
A3-7x14-2	7/14	1.011	Kapton	0.014	0.086	0.037	Kapton/H-Coat	0.011
A3-7x14-4	7/14	0.400	Neoprene	.110 to .142	7 strands	0.080	Tefzel	0.010
A3-7x14-5	7/14	0.476	Film(Corrugated)	0.012	0.112	0.070	Polyethylene	0.025
A5-Mx19-5	148/19	1.495	Polyethylene	0.060	0.068	0.036	Steel Messenger	-
			Tape (Glass)	0.006	0.236	0.080	Synthetic Rubber	0.078
			Polyvinyl Chloride	0.126	0.243	0.073	Proprietary Compound	0.085
			Polyethylene	0.123	0.068	0.068	Halar	0.021
			Al. Shield	0.012	0.127	0.068	Polyolefin	0.030
			Paper	.025	0.068	0.036	Polyethylene	0.016

TABLE 6-34. CONTINUED

SAMPLE NUMBER	CONDUCTORS AWG	CABLE JACKET		INDIVIDUAL CONDUCTORS				
		O.D. (IN)	MATERIAL	WALL THICKNESS (IN)	O.D. (IN)	WIRE DIAMETER (IN)	INSULATION	WALL THICKNESS (IN)
A6-4x12-1	4/12	0.515	Glass Braid	0.015	0.200	0.082	Silicone Rubber and Glass Braid	0.059
A7-6x19-4	6/19	0.518	Mylar Tape Polyvinyl Chloride Al. Shield Polyethylene Al. Shield Grease Impreg.	0.004 0.056 0.020 0.062 0.013	0.064	0.037	Polyethylene	0.014
A7-24x19-5	24/19	1.230	Polyvinyl Chloride Polyethylene Al. Shield Polyethylene Al. Shield Film/Shield Grease Impreg.	0.085 0.063 0.020 0.092 0.013 0.010	0.077	0.035	Polyethylene	0.021
A7-COAX-3	Coax.	1.075	Polyethylene Cu Shield	0.050 0.017	0.900	0.318	Copper Tube Foam Dielectric	0.291

7.0 RANKING OF MATERIALS

7.1 Fire Environment

7.1.1 Single Conductor Wires

A stated objective of the program is to rank the materials according to their performance in a fire environment. In Section 6.1 and Table 6-6, the materials are ranked according to their flammability performance. Sections 6.2 and 6.3 and Tables 6-12, 6-13, and 6-16 similarly rank the materials with respect to smoke emission and circuit integrity characteristics. The data contained in Tables 6-6, 6-13, and 6-16 form the data base for the ranking made in this section.

The criteria selected to establish the ranking of wire and cable insulating materials in a fire environment are:

- Flammability
- Smoke Emission
- Circuit Integrity

Each of these criteria have different degrees of importance, and therefore, weighting factors have to be assigned to ensure that each criterion has the correct amount of influence on the final result.

Note that although the reader may not agree with the weighting factors selected by the writers, the writers have made the rationale for their decisions clear. The reader can thus use the same approach with his/her rationale and perform the same set of operations and arrive at his/her own conclusion.

The approach used to establish the weighting factors was basically as described in Appendix A. However, rather than using the binary "0", "1" method, a "0" to "10" scaling method was used in which the two criteria being compared were awarded a number of points whose sum is 10. This approach was used in order to introduce a greater degree of sensitivity into the analysis. The results of the comparison of the criteria and the weighting factors assigned to each are shown in Table 7-1.

TABLE 7-1
MATERIAL RANKING CRITERIA WEIGHTING FACTORS

CRITERION	CHOICE TALLY		TOTAL	WEIGHTING FACTOR
Flammability	3	6	9	0.30
Smoke	7	7	14	0.47
Circuit Integrity	4	3	7	0.23
			30	1.00

Smoke emission was established as the most important criterion, with flammability next, and circuit integrity the least important.

The normalized performance factors tabulated in Table 7-2 were used as interim steps in the process of ranking the insulation materials. These factors are derived as the

TABLE 7-2 NORMALIZED PERFORMANCE FACTORS FOR MATERIALS TO BE RANKED

INSULATION MATERIAL	NORMALIZED PERFORMANCE FACTOR				
	FLAMMABILITY REF. TABLE 6-6	SMOKE EMISSION		CIRCUIT INTEGRITY REF. (TABLE 6-16)	
		REF. TABLE 6-12 (D _s (4))	REF. TABLE 6-13 (D _m)	4 MINUTES	20 MINUTES
Asbestos	0.306	0.001	0.018	0.000	0.253
EPR	0.601	0.267	0.512	0.583	0.917
Halar	0.541	0.051	0.539	0.959	0.992
Kapton	0.402	0.002	0.012	0.770	0.954
Mica	0.449	0.044	0.179	0.000	0.052
Polyester	0.702	0.466	0.611	0.978	0.996
Polyethylene	1.000	0.328	0.728	0.987	0.997
Polyolefin	0.705	0.955	0.953	0.741	0.948
Polyvinyl Chloride	0.650	1.000	1.000	0.948	0.990
Silicone Rubber	0.589	0.131	0.548	0.000	0.000
Teflon (PTFE)	0.507	0.001	0.006	0.900	0.980
Tefzel	0.580	0.068	0.424	0.928	0.986
Polyimide Coated Tefzel	① 0.580	0.011	0.057	① 0.928	① 0.986

① No test data, used Tefzel value.

ratio of the actual value of the performance to performance value of the worst case. For example, consider the performance of the various materials shown in Table 6-6 for the flammability test. The worst-case performer, Polyethylene, has a summation value of 12.080. Asbestos has a summation value of 3.697. Therefore, the normalized performance factor for asbestos is $3.697/12.080 = .306$. Polyolefin has a summation value of 8.522, making a normalized performance ratio of .705. Polyethylene has a normalized performance ratio of 1.000.

Smoke emission and circuit integrity test results were manipulated to obtain performance factors for each. Test performance for each of these characteristics was obtained using two different time bases. Four minutes was chosen as a circuit integrity base to correspond to the $D_s(4)$ (specific optical density at 4 minutes). Although D_m may occur at any time during the 20 minute smoke test, it will probably occur near the end of the test in the majority of cases. Therefore, 20 minutes was chosen as the circuit integrity base.

Smoke emission performance factors were determined by taking the mean values of $D_s(4)$ and D_m from Tables 6-12 and 6-13, respectively. PVC having the greatest mean $D_s(4)$ and D_m was given a 1.000 in each category, and other materials were given a smaller value by the ratio of their specific optical density to that of PVC.

The circuit integrity performance factors were obtained by manipulating the data from Table 6-16 according to the following formula:

$$\text{Performance Factor} = 1 - \left(\frac{t}{T} \right)$$

where: t = mean time to failure of each material in seconds.

T = time base of 4 minutes or 20 minutes in seconds (240 or 1,200).

By dividing the data into two categories, it is possible to make two rankings, one at 4 minutes and the other at 20 minutes, though the same flammability data are used in each ranking.

The final ranking of the materials was accomplished by weighting the normalized performance factors by the value established for the weighting factors derived in Table 7-1. The result of this operation is shown in Table 7-3.

TABLE 7-3 RANKING OF SINGLE CONDUCTOR WIRES

INSULATION MATERIAL	WEIGHTED PERFORMANCE FACTORS (REF. TABLES 7-1 AND 7-2)								SUMMATION OF FACTORS		RANK	
	WEIGHTING FACTOR	FLAMMABILITY (TABLE 6-6) X 0.300	SMOKE EMISSION		CIRCUIT INTEGRITY		4 MINUTES	20 MINUTES	4 MINUTES	20 MINUTES	4 MIN. MIN.	20 MIN.
			(TABLE 6-12)	(TABLE 6-13)	(TABLE 6-16)	(TABLE 6-16)						
			4 MINUTES	20 MINUTES	4 MINUTES	20 MINUTES						
		X 0.467	X 0.467	X 0.233	X 0.233	X 0.233	X 0.233					
Asbestos	0.0918	0.0005	0.0084	0.0000	0.0590	0.0923	0.1592	1	1			
Mica	0.1347	0.0205	0.0836	0.0000	0.0121	0.1552	0.2304	2	2			
Kapton	0.1347	0.0009	0.0056	0.1794	0.2223	0.3009	0.3485	4	3			
Teflon (PTFE)	0.1206	0.0005	0.0028	0.2097	0.2285	0.3623	0.3834	5	4			
Polyimide Coated Tefzel	0.1521	0.0051	0.0266	0.2162	0.2297	0.3953	0.4303	7	5			
Silicone Rubber	0.1740	0.0612	0.2559	0.0000	0.0000	0.2379	0.4326	3	6			
Tefzel	0.1767	0.0318	0.1980	0.2097	0.2283	0.3936	0.5784	6	7			
EPR	0.1767	0.1247	0.2391	0.1358	0.2137	0.4408	0.6331	9	8			
Halar	0.1803	0.0238	0.2517	0.2234	0.2311	0.4095	0.6451	8	9			
Polyester	0.1623	0.2176	0.2853	0.2279	0.2321	0.6561	0.7280	10	10			
Polyethylene	0.2106	0.1532	0.3400	0.2300	0.2323	0.6832	0.8723	11	11			
Polyolefin	0.3000	0.4460	0.4451	0.1727	0.2209	0.8302	0.8775	12	12			
Polyvinyl Chloride	0.2115	0.4667	0.4667	0.2209	0.2307	0.8826	0.8924	13	13			
	0.1950											
	0.1950											

Thus, it can be seen that, based on the available test data, a general ranking of the materials used for electrical wire insulation on rapid transit systems when exposed to a fire environment can be made as shown in Table 7-4.

TABLE 7-4 RANKING OF INSULATION MATERIALS

<u>4 Minutes</u>	<u>20 Minutes</u>
1. Asbestos	1. Asbestos
2. Mica	2. Mica
3. Silicone Rubber	3. Kapton
4. Kapton	4. Teflon (PTFE)
5. Teflon (PTFE)	5. Polyimide Coated Tefzel
6. Tefzel	6. Silicon Rubber
7. Polyimide Coated Tefzel	7. Tefzel
8. Halar	8. EP R
9. E P R	9. Halar
10. Polyester	10. Polyester
11. Polyethylene	11. Polyethylene
12. Polyolefin	12. Polyolefin
13. Polyvinyl Chloride	13. Polyvinyl Chloride

7.1.2 Multiconductor Cables

The method used to rank the performance of the material/construction of multiconductors was similar to that employed in 7.1.1 to rank single conductor wire.

The performance data were extracted from Tables 6-8 for flammability, 6-9 for smoke emission, and 6-17 for circuit integrity.

Table 7-5 shows the normalized performance rating derived from operating the raw data from Tables 6-8, 6-9, and 6-17.

Table 7-6 shows the effect of applying the weighting factors to the normalized performance data.

As can be seen from Table 7-6, multiconductor cables, when related to insulation materials in a fire environment, can be ranked by performance as shown in Table 7-7.

TABLE 7-5 NORMALIZED PERFORMANCE FACTORS - MULTICONDUCTOR CABLES

CABLE DESIGNATION/ DESCRIPTION	NORMALIZED PERFORMANCE FACTOR				
	FLAMMABILITY REF. TABLE 6-8	SMOKE EMISSION REF. TABLE 6-9		CIRCUIT INTEGRITY REF. TABLE 6-17	
		4 MINUTES	20 MINUTES	4 MINUTES	20 MINUTES
4-7X12-1 Polyethylene/Polyethylene	0.382	0.423	0.831	0.000	0.697
4-7X12-2 Polyethylene/Neoprene	0.435	0.434	0.635	0.000	0.540
6-7X12-1 Polyolefin/Polyolefin	0.597	1.000	1.000	0.000	0.743
13-7X14-1 Teflon (FEP)-Mica/Teflon	0.319	0.000	0.040	0.000	0.624
13-7X14-2 Tefzel-Mica/Tefzel	0.455	0.071	0.454	0.000	0.742
13-7X12-3 Kapton/Kepton	0.243	0.001	0.004	0.008	0.802
A3-7X14-1 Synthetic Rubber/Neoprene	0.259	0.527	0.427	0.000	0.000
A3-7X14-2 Synthetic Rubber/Neoprene	0.662	0.544	0.495	0.000	0.070
A3-7X14-4 Halar/Halar	0.549	0.034	0.292	0.483	0.897
A3-7X14-5 Polyolefin/Polyolefin	1.000	0.429	0.432	0.000	0.658
A6-4X12-1 Silicone Rubber/Glass Braid	0.466	0.107	0.383	0.000	0.000

TABLE 7-6 RANKING OF MULTICONDUCTOR CABLES

CABLE DESIGNATION/DESCRIPTION	WEIGHTED PERFORMANCE FACTORS (REF. TABLES 7-1 AND 7-5)						RANK	
	FLAMMABILITY (TABLE 6-8)	SMOKE EMISSION (TABLE 6-9)		CIRCUIT INTEGRITY (TABLE 6-17)		FACTOR SUMMATION		
		4 MINUTES	20 MINUTES	4 MINUTES	20 MINUTES	4 MINUTES	20 MINUTES	
		X 0.467	X 0.467	X 0.233	X 0.233	MINUTES	MINUTES	
WEIGHTING FACTOR	X 0.300	X 0.467	X 0.233	X 0.233	4 MINUTES	20 MINUTES	4 MIN. MIN.	20 MIN.
13-7X14-1	0.0957	0.0000	0.0187	0.0000	0.0957	0.2598	2	1
Teflon (FEP)-Mica/Teflon	0.0957	0.0005	0.0187	0.0019	0.0753	0.2617	1	2
13-7X12-3	0.0729	0.2461	0.0019	0.0000	0.3278	0.2771	7	3
Kapton/Kapton	0.0729	0.0500	0.1994	0.0000	0.1898	0.3187	4	4
A3-7X14-1	0.0777	0.2540	0.1789	0.0000	0.4526	0.4461	9	5
Synthetic Rubber/Neoprene	0.0777	0.0159	0.2312	0.1125	0.2931	0.5101	5	6
A6-4X12-1	0.1398	0.0332	0.1364	0.0000	0.1697	0.5214	3	7
Silicone Rubber/Glass Braid	0.1398	0.2027	0.2120	0.0000	0.3332	0.5528	8	8
A3-7X14-2	0.1986	0.2003	0.2965	0.0000	0.5003	0.6550	10	9
Synthetic Rubber/Neoprene	0.1986	0.1975	0.2017	0.0000	0.3121	0.6651	6	10
A3-7X14-4	0.1647	0.4667	0.3881	0.0000	0.6458	0.8189	11	11
Halar/Halar	0.1647		0.4667					
13-7X14-2	0.1365							
Tefzel-mica/Tefzel	0.1365							
4-7X12-2	0.1305							
Polyethylene/Neoprene	0.1305							
A3-7X14-5	0.3000							
Polyolefin/Polyolefin	0.3000							
4-7X12-1	0.1146							
Polyethylene/Polyethylene	0.1146							
6-7X12-1	0.1791							
Polyolefin/Polyolefin	0.1791							

TABLE 7-7 RANKING OF MULTICONDUCTOR CABLE INSULATIONS

<u>4 Minutes</u>	<u>20 Minutes</u>
1. Kapton/Kapton	1. Teflon (FEP)-Mica/Teflon
2. Teflon (FEP)-Mica/Teflon	2. Kapton/Kapton
3. Tefzel-Mica/Tefzel	3. Synthetic Rubber/Neoprene
4. Silicone Rubber/Glass Braid	4. Silicone Rubber/Glass Braid
5. Harlar/Harlar	5. Synthetic Rubber/Neoprene
6. Polyethylene/Polyethylene	6. Harlar/Harlar
7. Synthetic Rubber/Neoprene	7. Tefzel-Mica/Tefzel
8. Polyethylene/Neoprene	8. Polyethylene/Neoprene
9. Synthetic Rubber/Neoprene	9. Polyolefin/Polyolefin
10. Polyolefin/Polyolefin	10. Polyethylene/Polyethylene
11. Polyolefin/Polyolefin	11. Polyolefin/Polyolefin

The results are fairly consistent with the results obtained in Section 7.1.1.

7.2 Ranking of Materials Based on Additional Performance Tests

A secondary objective of the study program was to attempt to rank the wire and cable insulating materials based on characteristics in addition to the fire environment characteristics resulting in the testing discussed in Section 5.6 and reported in Section 6.4. The approach was similar to that employed in Section 7.1. However, after review of the test data available, it was concluded that there was insufficient collatable data available on which to base an analysis or to arrive at conclusions that could withstand any but the most casual scrutiny. Therefore, the materials are not being ranked based on the additional performance tests. The reader will have to review the test data and make whatever conclusion he/she can, based on the reader's requirement. The lack of test data can be directly attributed to the fact that the test samples were obtained in a rather sporadic fashion, depending on the availability of sample from the generosity of the wire suppliers. A more disciplined approach such as buying specific materials/constructions would have led to more usable results.

8.0 CONCLUSIONS

The objectives of the program have been achieved. However, inadequate attention was given to the testing of very large wire used in traction power circuits of transit systems. Only two samples of conductor were received that were larger than 500 MCM.

Test methods that can be used to determine the flammability, smoke emission, and circuit integrity characteristics of electrical wire and cable have been developed and documented.

The methods for flammability, smoke emission, and circuit integrity testing are simple to conduct, can be performed in practically any laboratory, are low in cost in respect to both the test facility and the test sample materials, and assess the performance of the insulating material as part of the wire and cable system.

The toxic gas emission test using small animals cannot be conducted in just any laboratory. Testing of this nature and analysis of the test data should only be undertaken by specialists working in a laboratory specializing in small animal testing.

The test methods are sufficiently accurate and are of sufficient sensitivity to allow an evaluator to determine the performance and acceptability of a particular material/construction when exposed to a fire environment.

The wire and cable manufacturers were very responsive and cooperative throughout the program. Their cooperation can be measured by the fact that they provided approximately 60,000 feet of wire and cables for test purposes and they willingly provided detailed information about their products despite the possibility that the results of the study might be unfavorable.

The rapid transit authorities and vehicle manufacturers showed interest in the program and the study results.

The results of the fire test portion of the study indicate the following:

1. The types of wire and cable insulation predominantly in use on rapid transit systems perform poorly in a fire environment when the hazards of flammability, smoke toxicity, and circuit integrity are considered as a whole, i.e., for single conductor wires, polyolefin, polyethylene, and polyvinyl chloride insulated wires are the poorest performers. For multiconductor cables, constructions using polyethylene, polyolefin, synthetic rubber, and neoprene or combinations of these materials were the poorest performers.
2. There are insulating materials available that can provide significant improvement in combating the hazards of a fire environment. For single conductor wire, asbestos, mica, Kapton, silicone rubber, and Teflon all have significantly better ratings than the materials predominantly in use today. Polyimide-coated Tefzel also performed well and serves to illustrate the importance of construction details in improving the performance over that of the basic material. For multiconductor cables, the same general pattern is true. Wires insulated and protected with Kapton, silicone rubber, mica, and Teflon or combinations of these materials are the better performers.
3. It is impractical to estimate the performance of a single conductor wire or a multiconductor cable on the basis of the results obtained for the primary insulation material only. For example, the jacket material applied to silicone rubber to achieve abrasion resistance and other mechanical properties can significantly affect its flame resistant qualities, as was demonstrated by the silicone rubber/glass/terylene wire. Therefore, the entire construction of the wire or cable must be reviewed prior to any assessment of its behavior in a fire environment. For this reason, it is important that the results of this study not become numbers that are bandied about and used to substantiate decisions that did not take into account the construction details.

The results of the other performance tests were disappointing. There were insufficient test samples/test data to rank the overall performance of the

wire and cable. This lack can be directly attributed to the contractor's approach to obtaining test samples, i.e., an appeal to wire and cable manufacturers to submit candidate materials/constructions. The result was a random selection of materials, constructions, and sizes rather than a controlled set of test samples.

The data obtained as a result of the study should be used to form the basis of a data bank that can be made available to the public.

The results of this study must be kept in perspective with other criteria when electrical wire and cable selection/usage decisions are being made. Flammability characteristics must not be allowed to overshadow other very important characteristics that must be considered, e.g., abrasion resistance, fluid immersion resistance, flexibility, ease of termination, elongation, tensile strength, bend radius, insulation resistance, dielectric strength, cost, and availability.

9.0 RECOMMENDATIONS

- It is recommended that the rapid transit industry establish a set of weighted criteria to govern the selection of electrical wire and cable for rapid transit systems. The criteria and the weighting factors should be based on a systems analysis of potential areas of application. The criteria should include, but not be limited to, the following:
 - Flammability
 - Smoke and toxic gas
 - Circuit integrity
 - Abrasion resistance
 - Ease of termination
 - Elongation
 - Fluid immersion resistance
 - Flexibility
 - Tensile strength
 - Minimum bend radius
 - Insulation resistance
 - Dielectric strength
 - Cost
 - Availability

- It is recommended that a study of circuit integrity applicable to rapid transit systems be undertaken to define a high integrity circuit, identify circuits that can be classified as high integrity circuits, and identify standard approaches to the design and installation of circuits. Techniques such as redundancy and fail-safe circuits should be considered as alternatives to brute force methods, such as heavily insulated wire and cable.

- It is recommended that the rapid transit industry immediately phase into use of the insulation materials that are highly ranked as a result of this study. However, the industry should, at the same time and of its own volition, develop and apply standard practices for the termination, fabrication, installation, and maintenance of electrical wire bundles.

- It is recommended that the raw data contained in this report be used as the initial input to a national data base governing the behavior of electrical wire and cable when exposed to a fire environment.
- It is recommended that additional work be done to develop a standard method of evaluating the results of toxic gas testing of wire and cable, i.e., the results should be based on toxic effect per unit length per AWG size rather than toxic effect of a predetermined mass of the insulating material.

APPENDIX A

Method of Performing Comparative Analysis

The selection of one test method from a group of candidate test methods and the selection of one wire insulation material from a group of candidate insulation materials is usually the result of deciding which test method or insulating material best meets the criteria established by the evaluator. However, before comparing the candidates to the criteria, it is important to recognize that not all of the criteria have the same importance. For example, when purchasing a pair of shoes, some of the selection criteria are fit, color, style, and cost. Obviously, to the average person, fit is more important than style. The important task is therefore to quantify the degree of importance or weighting factor assigned to each of the selection criteria. David Hester, a noted human factors researcher, has noted in his book Human Factors Theory and Practice that "the determination of the weight or value each criterion should have in a particular system is entirely subjective" judgement on the part of the developer. However, he goes on to state that "The procedure for assigning mathematical weights to these criteria, taken from Hagen (1967) merely formalizes and quantizes that judgement. It has value in forcing the specialist or the evaluator to make his decision biases visible. In actual development few designers/evaluators quantize their judgements which makes these easy prey to irrational persuasions...." Since it was a goal of the investigators assigned to this study not to become easy prey to irrational persuasions, it was decided to use the method developed by Hagen and illustrated below.

Consider a local government whose task it is to select a public transportation system for use in its area of jurisdiction. The potential selection criteria have been identified, i.e., performance, initial cost, reliability, manufacturability, maintainability, safety, operating costs, and energy requirements. The weighting factors for each of these criteria are calculated as follows and are shown in Table A-1. Note that the value of Table A-1 is only to illustrate the method. However, if the reader does not agree with the assessment, at least the difference of opinion can be identified.

Weights are assigned by comparing each potential criterion with every other and assigning a value of one (1) to whichever is judged to be more important and zero (0)

to the less important of the two criteria. For example, if performance requirements are more important than initial cost, then a value of 1 is allocated to performance and 0 to initial cost. Performance is then compared with each of the other remaining criteria in a similar manner. In Table A-1, the comparisons of performance and the other criteria are emphasized by the shaded area. The next criterion, initial cost, is compared with the remaining criteria and this process is continued until all the criteria have been compared against each other.

The 1's for each criterion are then added across Table A-1 as shown in the total column and then divided by the total number of 1's, i.e., in this case 28, to derive a normalized weighting factor. This now gives the evaluators a weighting factor for each criterion. It should be emphasized that the weighting factor is a relative value indicating the importance of one criterion relative to all other criterion and is not an absolute value.

This method was applied to determine the weighting factors that should be applied to the potential selection criteria discussed in Section 4 for the selection of the flammability, smoke emission, and critical circuit test methods. It was also used to determine the importance of the various characteristics of the wire and cable considered when ranking the insulations in Section 7.

The tables that make the contractor decision biases visible are contained herein as Tables A-2 through A-11.

TABLE A-1. EXAMPLE OF ASSIGNMENT OF WEIGHTING FACTORS TO SELECTION CRITERIA.

CRITERIA	CHOICE TALLY	TOTAL	WEIGHTING FACTOR
Performance	1 1 1 1 0 1 1	6	.214
Initial Cost	0 0 1 1 0 0 1	3	.107
Reliability	0 1 1 1 0 0 1	4	.143
Manufacturability	0 0 0 0 0 1 1	2	.071
Maintainability	0 0 0 1 0 0 1	2	.071
Safety	1 1 1 1 1 1 1	7	.250
Operating Costs	0 1 1 0 1 0 1	4	.143
Energy Requirements	0 0 0 0 0 0 0	0	0
		<hr/>	<hr/>
		28	.999

TABLE A-2. ASSIGNMENT OF WEIGHTING FACTORS TO FLAMMABILITY TEST SELECTION CRITERIA (REF. SECTION 4.1.2)

CRITERIA	CHOICE TALLY	TOTAL	WEIGHTING FACTOR
Ignition Characteristics	1 1 1 1 1 1 1	7	.250
Existing Method	0 0 1 1 1 1 0	4	.143
Repeatability	0 1 1 1 1 1 1	6	.214
All Sizes	0 0 0 1 1 1 0	3	.107
Low Cost	0 0 0 0 1 1 1	3	.107
Simplicity	0 0 0 0 0 1 0	1	.036
Simulate Installation	0 0 0 0 0 0 0	0	0
Any Laboratory	0 1 0 1 0 1 1	4	.143
		<hr/>	<hr/>
		28	1.000

TABLE A-3. ASSIGNMENT OF WEIGHTING FACOTRS TO SMOKE TEST SELECTION CRITERIA
(REF. SECTION 4.2.2)

CRITERIA	CHOICE TALLY	TOTAL	WEIGHTING FACTOR
Smoke Characteristics	1 1 1 1 1 1 1	7	.250
Existing Method	0 0 0 1 1 1 1	4	.143
Repeatability	0 1 1 1 1 1 1	6	.214
All Sizes/ Constructions	0 1 0 1 1 1 1	5	.179
Low Cost	0 0 0 0 1 1 1	3	.107
Simple	0 0 0 0 0 1 1	2	.072
Simulate Installation	0 0 0 0 0 0 0	0	0
Simulate Fire	0 0 0 0 0 0 1	1	.036
		<u>28</u>	<u>1.001</u>

TABLE A-4. ASSIGNMENT OF WEIGHTING FACTORS TO CIRCUIT INTEGRITY TEST SELECTION CRITERIA
(REF. SECITON SECTION 4.4.2)

CRITERIA	CHOICE TALLY	TOTAL	WEIGHTING FACTOR
Integrity Characteristics	1 1 1 1 1 1	6	.285
Existing Method	0 0 0 0 0 1	1	.048
Repeatability	0 1 1 1 1 1	5	.238
All Wire Sizes	0 1 0 1 1 1	4	.190
Low Cost	0 1 0 0 0 1	2	.095
Any Laboratory	0 1 0 0 1 1	3	.143
Simulate Installation	0 0 0 0 0 0	0	0
		<u>21</u>	<u>1.000</u>

TABLE A-5 SMOKE TEST METHOD SELECTION
 CANDIDATE METHODS VERSUS SMOKE DENSITY MEASUREMENT CAPABILITY
 (Weighting Factor 0.25) (Ref. Table 4-10)

TEST METHOD	CHOICE TALLY	TOTAL	CHOICE COEFF.	CHOICE X .25
Arapahoe	1 0 1 0 0 0 0 0	2	.056	.014
Cass	0 0 0 0 0 0 0 0	0	0	0
Rohm & Haas	1 1 1 1 1 0 0 0	5	.139	.035
E-162	0 1 0 1 0 0 0 0	2	.056	.014
Steiner Tunnel	1 1 0 0 0 0 0 0	2	.056	.014
Building Research Institute	1 1 0 1 1 0 0 0	4	.111	.028
Commonwealth Exp. Building	1 1 1 1 1 1 0 0	6	.167	.042
Lawrence Radiation Laboratory	1 1 1 1 1 1 1 0	7	.194	.049
NBS	1 1 1 1 1 1 1 1	8	.222	.056
		36	1.001	

TABLE A-6. SMOKE TEST METHOD SELECTION CANDIDATE TEST METHODS VERSUS REPEATABILITY
(WEIGHTING FACTOR 0.214) (REF. TABLE 4-10)

TEST METHOD	CHOICE TALLY	TOTAL	CHOICE COEFF.	CHOICE X.214
Arapahoe	0 1 0 1 1 1 1 1	6	.167	.036
Cass	1 1 1 1 1 1 1 1	8	.222	.048
Rohm & Haas	0 0 0 0 0 1 0 0	1	.028	.006
E-162	1 0 1 1 0 0 0 0	3	.083	.018
Steiner Tunnel	0 0 1 0 0 0 0 0	1	.028	.006
Building Research Institute	0 0 1 1 1 1 0 0	4	.111	.024
Commonwealth Exp. Building	0 0 0 1 1 0 0 0	2	.056	.012
Lawrence Radiation Laboratory	0 0 1 1 1 1 1 0	5	.139	.030
NBS	0 0 1 1 1 1 1 1	6	.167	.036
		<u>36</u>	<u>1.001</u>	

TABLE A-7 SMOKE TEST METHOD SELECTION
 CANDIDATE TEST METHODS VERSUS ABILITY TO TEST ALL SIZES AND CONSTRUCTIONS
 (WEIGHTING FACTOR 0.179) (REF. TABLE 4-10)

TEST METHOD	CHOICE TALLY	TOTAL	CHOICE COEFF.	CHOICE X .179
Arapahoe	0 0 0 0 0 0 0 0	0	.000	.000
Cass	1 0 0 0 1 0 0 0	2	.056	.010
Rohm & Haas	1 1 0 0 1 1 0 0	4	.111	.020
E-162	1 1 1 0 1 1 0 0	5	.139	.025
Steiner Tunnel	1 1 1 1 1 1 1 1	8	.222	.040
Building Research Institute	1 0 0 0 0 0 0 0	1	.028	.005
Commonwealth Exp. Building	1 1 0 0 0 1 0 0	3	.083	.015
Lawrence Radiation Laboratory	1 1 1 1 0 1 1 0	6	.167	.030
NBS	1 1 1 1 0 1 1 1	7	.194	.035
		36	1.000	

TABLE A-8. SMOKE TEST METHOD SELECTION — CANDIDATE TEST METHODS VERSUS EXISTING WIRE TEST METHODS (WEIGHTING FACTOR 0.143) (REF. TABLE 4-10)

TEST METHOD	CHOICE TALLY	TOTAL	CHOICE COEFF.	CHOICE X.143
Arapahoe	0 0 0 0 1 1 0 0	2	.056	.008
Cass	1 0 0 0 1 1 0 0	3	.083	.012
Rohm & Haas	1 1 0 0 1 1 0 0	4	.111	.016
E-162	1 1 1 0 1 1 0 0	5	.139	.020
Steiner Tunnel	1 1 1 1 1 1 1 1	8	.222	.032
Building Research Institute	0 0 0 0 0 0 0 0	0	0	0
Commonwealth Exp. Building	0 0 0 0 0 1 0 0	1	.028	.004
Lawrence Radiation Laboratory	1 1 1 1 0 1 1 0	6	.167	.024
NBS	1 1 1 1 0 1 1 1	<u>7</u>	<u>.194</u>	.028
		36	1.000	

TABLE A-9. SMOKE TEST METHOD SELECTION — CANDIDATE TEST METHODS VERSUS COST OF TEST
(WEIGHTING FACTOR 0.107) (REF. TABLE 4-10)

TEST METHOD	CHOICE TALLY	TOTAL	CHOICE COEFF.	CHOICE X.107
Arapahoe	0 1 1 1 1 1 1 1	7	.194	.021
Cass	1 1 1 1 1 1 1 1	8	.222	.024
Rohm & Haas	0 0 0 1 1 1 1 1	5	.139	.015
E-162	0 0 1 1 1 1 1 1	6	.167	.018
Steiner Tunnel	0 0 0 0 0 0 0 0	0	0	0
Building Research Institute	0 0 0 0 1 1 0 0	2	.056	.006
Commonwealth Exp. Building	0 0 0 0 1 0 0 0	1	.028	.003
Lawrence Radiation Laboratory	0 0 0 0 1 1 1 0	3	.083	.009
NBS	0 0 0 0 1 1 1 1	4	.111	.012
		<u>36</u>	<u>1.000</u>	

TABLE A-10. SMOKE TEST METHOD SELECTION — CANDIDATE TEST METHODS VERSUS SIMPLICITY
 (WEIGHTING FACTOR 0.072) (REF. TABLE 4-10)

TEST METHOD	CHOICE TALLY	TOTAL	CHOICE COEFF.	CHOICE X.072
Arapahoe	0 0 0 1 1 1 0 0	3	.083	.006
Cass	1 1 1 1 1 1 0 0	6	.167	.012
Rohm & Haas	1 0 1 1 1 1 0 0	5	.139	.010
E-162	1 0 0 0 1 1 0 0	3	.083	.006
Steiner Tunnel	0 0 0 1 0 0 0 0	1	.028	.002
Building Research Institute	0 0 0 0 1 1 0 0	2	.056	.004
Commonwealth Exp. Building	0 0 0 0 1 0 0 0	1	.028	.002
Lawrence Radiation Laboratory	1 1 1 1 1 1 1 0	7	.194	.014
NBS	1 1 1 1 1 1 1 1	8	.222	.016
		36	1.000	

TABLE A-11. SMOKE TEST METHOD SELECTION — CANDIDATE TEST METHODS VERSUS SIMULATION OF FIRE (WEIGHTING FACTOR 0.036) (REF. TABLE 4-10)

TEST METHOD	CHOICE TALLY	TOTAL	CHOICE COEFF.	CHOICE X .036
Arapahoe	1 0 0 0 1 1 0 0	3	.083	.003
Cass	0 0 0 0 1 1 0 0	2	.056	.002
Rohm & Haas	1 1 0 0 1 1 0 0	4	.111	.004
E-162	1 1 1 0 1 1 0 0	5	.139	.005
Steiner Tunnel	1 1 1 1 1 1 1 1	8	.222	.008
Building Research Institute	0 0 0 0 0 0 0 0	0	0	0
Commonwealth Exp. Building	0 0 0 0 0 1 0 0	1	.028	.001
Lawrence Radiation Laboratory	1 1 1 1 0 1 1 0	6	.167	.006
NBS	1 1 1 1 0 1 1 1	7	.194	.007
		<u>36</u>	<u>1.000</u>	

APPENDIX B

Analysis of Existing Smoke Test Methods

B1.0 ARAPAHOE

The combustion chamber of the Arapahoe smoke test measures 30 by 5 by 5 inches. An instrument cabinet and a sand mill are required accessories. The Arapahoe smoke chamber should be installed in a fume hood when tests are conducted.

Standard samples are cut 1-1/2 by 1/2 by 1/8 inch thick. Samples are weighed and the weight recorded. Similarly, the weight of the filter paper is determined and recorded.

The filter paper is installed in a holder that is positioned at the top of the combustion chamber chimney. The sample is placed in the sample holder. Air flow is adjusted to 4.5 cfm. The gas (propane) is turned on and the gas flow control is adjusted to give a reading of 8.3 on the flowmeter scale. The propane microburner is then ignited.

The combustion chamber door is then closed. This starts the timer and ignites the sample, beginning the test. The sample is allowed to burn for 30 seconds, after which the gas is turned off to extinguish the sample. (If the sample is not self-extinguishing, it must be extinguished with nitrogen or air blast. In this case, care must be taken because too strong a blast can cause smoke to be lost from the chimney, invalidating the data.) After the gas is turned off, the air flow is continued for 30 additional seconds, for a total of 60 seconds recorded by the timer, and then turned off.

After the test, the filter paper and samples are carefully removed and the weights recorded. The burned sample is then placed in the sand mill and decharred for 45 minutes at 60 rpm.. After being removed from the sand mill, the decharred sample is thoroughly cleaned and weighed. The following calculations are then made:

Total amount burned = (initial sample weight) - (decharred sample weight)

Smoke weight = (filter + smoke weight) - (initial filter weight)

Char weight = (burned sample weight) - (decharred sample weight)

Percent smoke = $\frac{\text{Smoke weight}}{\text{Total amount burned}}$

Percent char = $\frac{\text{Char weight}}{\text{Total amount burned}}$

Advantages of the Arapahoe smoke test include short test time, good repeatability, relatively low cost (test setup and materials), and designed as a smoke test. Disadvantages are the small sample size which is best for test coupons cut from sheet material, smoke emission calculated as weight loss, not measuring the obscurance of light, 45 minutes required for decharring of samples, short flame time not igniting some samples, and possible errors when samples are extinguished by air blast.

B2.0 ASTM D 2843 (ROHM AND HASS XP2)

The XP2 smoke density test developed by the Rohm and Haas Company for measuring the rate of smoke generation and its visibility-obscuring effects employs a cabinet measuring 30 by 12 by 12 inches, completely enclosed except for 1-inch-high ventilating openings around the bottom. The specimen sizes used range from 1 by 1 by 1/4 inch, used by Rohm and Haas, to 2 by 2 by 2 inches, used by Wayne State University. These obviously give varying results, the larger size specimens giving higher maximum smoke density levels and more rapid smoke production rates. The heat source is a propane-air flame from a Bernz-O-Matic TX-1 pencil-tip burner, applied at a 45° angle for a maximum of 4 minutes.

This test does not have the versatility of the National Bureau of Standards test in differentiating between flaming and nonflaming (smoldering) conditions and in controlling the degree of ventilation. Exposure to the test flame is such that three of the six surfaces are exposed to flaming conditions, but the other three surfaces are not necessarily under nonflaming conditions. The degree of ventilation is fixed by the bottom opening. The XP2 test has two significant disadvantages: smoke stratification can produce serious variation, as indicated by the occasional increase in smoke density above the maximum recorded during the test when the exhaust blower is started, and it is much more difficult to separate the effects of specimen thickness and surface area. The XP2 test, however, makes it easier to vary total specimen

volume and thus obtain a measure of the effect of the maximum extent of involvement of the material in a poorly ventilated system. For example, the maximum involvement possible in a polyurethane foam mattress measuring 6.0 by 4.5 by 0.5 feet, in a room measuring 20 by 12.5 by 8 feet, with a volume ratio of 13.5 to 2000 cubic feet, can be scaled down to a specimen volume of 29.2 cubic inches in the XP2 test.

The test specimen is exposed to flame for the duration of the test, and the smoke is substantially trapped in the chamber in which combustion occurs. A 1 by 1 by 1/4 inch specimen is placed on a supporting metal screen and burned in a laboratory test chamber under active flame conditions using a propane burner operating at a pressure of 40 psi. The 12 by 12 by 31 inch test chamber is instrumented with a light source, a photoelectric cell, and a meter to measure light absorption horizontally across the 12 inch beam path. The chamber is closed during the 4 minute test period except for the 1 inch high ventilation openings around the bottom.

The light absorption data are plotted versus time. Two indexes are used to rate the material: maximum smoke produced and the smoke density rating.

B3.0 NSB SMOKE CHAMBER

The smoke test developed by the National Bureau of Standards employs a completely closed cabinet, measuring 3 by 3 by 2 feet, in which a specimen 3 inches square is supported in a frame so that a surface area 2-9/16 inches square is exposed to heat under either flaming or nonflaming (smoldering) conditions. The heat source is a circular foil radiometer adjusted to give a heat flux of 2.5 watts per square centimeter at the specimen surface. The photometer path for measuring light absorption is vertical to minimize measurement differences due to smoke stratification that could occur with a horizontal photometer path at a fixed height, and the full 3-foot height of the chamber is used to provide an overall average for the entire chamber. Smoke measurements are expressed in terms of specific optical density, which represents the optical density measured over unit path length within a chamber of unit volume produced from a specimen of unit surface area; since this value is dimensionless, it has the advantage of presenting smoke density independent of chamber volume, specimen size, or photometer path length, provided a consistent dimensional system is used.

This test provides additional information, including maximum smoke accumulation, maximum smoke accumulation rate, time to reach maximum smoke density, and time to reach a critical smoke density. The last property, also called obscuration time, is of considerable practical value since it is a measure of the time available before a typical occupant in a typical room would find his vision obscured by smoke sufficiently to hinder escape. The value of specific optical density describing this critical level is 16 and is necessarily arbitrary, based on 16 percent light transmittance over a 10-foot viewing distance in a room measuring 12.5 by 20 by 8 feet in which 10 square feet of the subject material were exposed.

The NBS smoke chamber has been proposed as a standard for wiring testing by such groups as the American Society for Testing and Materials (ASTM) and the Federal Aviation Administration (FAA). In addition to providing smoke test data, the chamber can be used to sample the combustion gases to determine the degree of toxic constituents present.

B4.0 LAWRENCE RADIATION LABORATORY

The Lawrence Radiation Laboratory smoke test uses a modified NBS smoke chamber. The chamber has been modified to allow it to be sealed or ventilated at will. The NBS smoke chamber has no ventilation. The Lawrence modification allows ventilation to be varied between 0 and 20 air changes per hour. No reports of wire and cable testing using the Lawrence modification were disclosed during this study.

B5.0 COMMONWEALTH EXPERIMENTAL BUILDING STATION

The Commonwealth Experimental Building Station smoke test uses a test specimen 50 millimeters in diameter, with a surface exposed for the test. The test employs a chamber having a volume of 5.7 cubic meters. The sample is heated by radiation at 3.5 watts per square centimeter. The test may be conducted in a flaming or nonflaming (smoldering) mode. Oxygen is controlled between 10 and 21 percent in the atmosphere within the chamber, and ignition is obtained through an electric shock. Time of test is that required to reach maximum concentration. Results are expressed as specific optical density.

Few details concerning this test could be determined.

B6.0 ASTM E 84 (STEINER TUNNEL)

The 25 foot tunnel test developed by Steiner is perhaps the most widely accepted test for surface flammability. It requires a specimen 24 feet long and 20 inches wide, conditioned to a constant weight at a temperature of $70^{\circ} \pm 5^{\circ}\text{F}$ ($21^{\circ} \pm 2.8^{\circ}\text{C}$) and at a relative humidity of 35 to 40 percent. The specimen is mounted face down so as to form a roof of a 25 foot long tunnel 17-1/2 inches wide and 12 inches high. The fire source is two gas burners 1 foot from the fire end of the sample and 7-1/2 inches below the surface of the sample. The fire source is adjusted so that a test sample of select-grade red-oak flooring would spread flame 19-1/2 feet from the end of the igniting fire in 5-1/2 minutes \pm 15 seconds. The end of the igniting fire is considered as being 4-1/2 feet from the burners, the flame being due to an average air velocity of 240 ± 5 feet per minute. Flame spread classification is determined on a scale on which asbestos-cement board is 0 and select-grade red-oak flooring is 100. Fuel contributed, smoke density, and the flamespread rate are recorded in this test, although there is not necessarily a relationship among these three measurements.

A light source is mounted on a horizontal section of the 16 inch diameter vent pipe at a point where it is preceded by a straight run of pipe of at least 16 feet and where it will not be affected by flame in the test chamber, located not more than 40 feet from the vent end of the chamber. The light beam is directed upward along the vertical axis of the vent pipe. A photoelectric cell, the output of which is directly proportional to the amount of light received, is mounted over the light source and connected to a recording device for indicating changes in the attenuation of incident light by passing smoke, particulates, and other effluents. The photoelectric cell output is automatically recorded immediately prior to the test and at least every 15 seconds during the test. The change in photoelectric cell readings are separately plotted on suitable coordinate paper. The area under the resultant smoke curve is compared with those of asbestos-cement board and select-grade red-oak flooring. A number is established for the material tested so that it may be compared with that of the asbestos-cement board and select-grade red-oak flooring, which have been arbitrarily established as 0 and 100, respectively. The test method notes that allowance should be made for accumulation of soot and dust on the photoelectric cell during the test, but does not specify how this is done.

The test is conducted on the sample for a 10 minute period unless the specimen is completely consumed in the fire area before that time, in which case the test is ended after complete combustion occurs.

It should be noted that with the Steiner tunnel there has been no standard or reference limit established for electrical cables. However, in their attempt to set this limit, UL has been using a 15 minute flame exposure time as reference to determine approximate effect. The time of exposure, the extent of fill of the cable tray, the allowable limits for burn length, and the smoke density have not been finalized as yet.

B7.0 ASTM E 162

The ASTM E 162 test, essentially a test of surface flammability, also provides a measure of smoke production by collecting a smoke deposit by vacuum for subsequent weighing.

This method for measuring surface flammability of materials employs a radiant heat source consisting of a 12 by 18 inch panel in front of which an inclined 6 by 18 inch specimen of the material is placed. The specimen is oriented so that ignition is forced near its upper edge and the flame front progresses downward.

A factor derived from the rate of progress of the flame front (ignition properties) and another relating to the rate of heat liberation by the material under test are combined to provide a flame spread index. Provision is also made for measurement of the smoke produced during tests.

The smoke sampling device is installed in the stack of the test apparatus. A single layer of glass fiber filter paper above the stack is used to collect the smoke deposit. An aspirator or pump and a flowmeter capable of maintaining a constant airflow velocity equivalent to 40 feet per minute of air at 70°F at the face of the 7/8 inch diameter filter disk are required. A photometer using an S-4 type photosensitive surface together with an incandescent light source are used for optical density measurements of the deposited smoke film over a density range of 0 to 4.5.

The test specimen is 6 by 18 inches by the sheet thickness. Specimens are prepared by predrying for 24 hours at 140°F and then conditioned to equilibrium at an ambient temperature of 73° ± 5°F and a relative humidity of 50 ± 5 percent.

The procedure described here is focused on smoke measurement. Some of the details of the procedure relating to the development of the flame spread index may be omitted. The glass fiber filter paper is weighed to an accuracy of 0.0001 gram. The smoke sampling device is placed in position above the stack and the flow rate is adjusted. The test is completed when the flame front has progressed the full length of the specimen or after an exposure time of 15 minutes, whichever occurs earlier.

At the conclusion of the test, the glass fiber filter paper is reweighed and the smoke deposit is recorded to the nearest 0.0001 gram. This weight is corrected for the loss of equilibrium moisture content of the glass fiber filter disks. The magnitude of the correction is determined by measuring the loss in weight of the disk during a test exposure of an asbestos-cement board specimen. After weighing, the smoke sampling filter disk is measured with a transmission densitometer, and a comparison is made of the smoke deposit area of the disk with the clear peripheral area.

The report of the test results includes the weight of the smoke deposit and the optical density when measurements are within the range of 0 to 4.5.

B8.0 BUILDING RESEARCH INSTITUTE, JAPAN

The Building Research Institute of Japan smoke test employs a chamber of 0.5 cubic meter volume. The specimen used weighs one gram. An electric furnace is used as the method of heating and the temperature is varied between 300° to 550°C. The test may be conducted in a flaming or nonflaming mode, controlled by the temperature. Air supply is described as free convection. Test results are reported as smoke generation coefficients. Little could be determined about this test method.

B9.0 ASTM D 757 (CASS)

A smoke test developed by Cass employs the ASTM D 757 global flammability testing apparatus. This method collects by filtering all the smoke evolved from a known weight of material and gives the results in percent smoke by weight.

Additional equipment required for this test includes:

- a. A coarse 9 cm diameter fritted glass funnel with the sides cut off.
- b. Glass fiber filter paper 9 cm diameter circles.
- c. Ring stand and clamp for supporting fritted glass funnel.
- d. An adequate source of vacuum.

The sample to be tested should weigh between 0.200 and 0.400 gram. The filter paper and the specimen to be tested should be weighed to the nearest milligram on an analytical balance.

Vacuum is applied to the filter, and the filter paper is laid on the filter using tweezers. The filter assembly is then placed in position about 4 to 8 cm above the globar. The globar power is applied. When the globar reaches the proper temperature, 950°C, the specimen is placed (using tweezers) about 2 to 4 mm below the red hot globar. Ignition will take place from 0 to 20 seconds and burning may require 10 to 30 seconds.

The smoke will be collected on the filter paper. A cinder residue may result in addition to the smoke. To ensure that no smoke particles are lost when the vacuum is released, the filter is removed from the globar and turned over, thus placing the filter paper on top. The vacuum is then released. The filter paper is removed with tweezers and weighed. The residue is weighed. The quantity of smoke is calculated as follows:

$$\frac{\text{Weight of smoke on filter paper}}{\text{Weight of specimen}} \times 100 = \text{percent smoke}$$

The time required for the test is about 5 to 10 minutes. This method is limited by the specimen size that the apparatus can handle. It is suitable for similar specimens cut from sheet or bar stock when several materials are to be combined. However, it is not readily adaptable to the variations in wire gauge sizes, insulation thicknesses, cable constructions, etc., which would be required for a suitable wire and cable test.

APPENDIX C

IEEE-383-1974 TEST METHOD

TITLE:

IEEE Standard for Type Test of Class IE Electric Cables, Field Splices, and Connections for Nuclear Power Generating Stations.

GENERAL PROVISIONS

This standard provides direction for establishing type tests that may be used in qualifying Class IE electric cables, field splices, and other connections for service in nuclear power generating stations. Though intended primarily to pertain to cable for field installation, this guide may also be used for qualification of internal wiring of manufactured devices.

EXAMPLES OF TYPE TESTS

Type tests described in this document are examples of methods that may be used to qualify electrical cables, field splices, and connections for use in nuclear power generating stations. Tests of the cable or connection assembly, as applicable, should then supplement the cable tests in order to qualify the connections and other aspects unique to planned usage.

The samples tested should contain the conductor, insulation, fillers, jacket, binder tape, overall jacket, shielding, and field splices that are representative of the cable category being qualified.

Flame Tests:

The fire should demonstrate that the cable does not propagate fire even if its outer covering and insulation have been destroyed in the area of flame impingement. The fire test should approximate installed conditions and provide consistent results. The test should be conducted in a naturally ventilated room or enclosure free from excessive drafts and spurious air currents.

The vertical tray configuration is recommended as the best arrangement to establish whether or not a cable could propagate a fire. The tray should be a vertical metal ladder type, 3 inches deep, 12 inches wide, and 8 feet long. The tray may be bolted at the bottom to a length of horizontal tray for support.

Multiple lengths of cable should be arranged in a single layer filling at least the center 6-inch portion of the tray with a separation of approximately 1/2 the cable diameter between each cable. The test should be conducted three times to demonstrate reproducibility using different samples of cable.

When specified, the following flame source should be used:

A ribbon gas burner shall be mounted horizontally such that the flame impinges on the specimen midway between the tray rungs and so that the burner is 3 inches behind and approximately 2 feet above the bottom of the vertical tray. Because of its uniform heat content, natural grade propane is preferred to commercial gas. The flame temperature should be approximately 1500^oF when measured by a thermocouple located in the flame close to, but not touching the surface of the test specimens (about 1/8 inch spacing).

When specified, the following alternate flame source should be used. Use a 24 inch square piece of 9 ounce burlap, folded into a bundle 4 inches x 4 inches x 6 inches. Wrap with fine copper wire to retain the shape of the bundle. Immerse in a container of oil, such as Mobilect 33, for five minutes. Remove and hang free in air, allow to drain for approximately 15 minutes. The burlap ignitor is weighed before immersion and after draining, and the fuel pick-up should be 160 ± 5 g. Temperature should be monitored at the point of maximum flame impingement upon the test cables. After draining, the ignitor should be placed in front of, and approximately 2 feet above, the bottom of the tray with the 4 inch x 6 inch face of the ignitor held in place against the cables by a suitable metal wire or band. Ignite the oil soaked burlap. The applied flame should be allowed to burn itself out naturally.

Evaluation:

Cables that propagate the flame and burn the total height of the tray above the flame source fail the test. Cables that self-extinguish when the flame source is removed or burn out pass the test. Cables that continue to burn after the flame source is shut off or burns out should be allowed to burn in order to determine the extent.

For more specific details, consult the actual standard.

APPENDIX D

Report of Inventions

A review of the work performed under this contract discloses no new invention or discovery. However, a great deal of new data was generated concerning the flammability and smoke emission characteristics of a large number of different types of electrical wire and cable insulation using standard test procedures. In addition, a novel test procedure was used to determine circuit integrity under direct flame impingement. The resulting test data was used to rank the insulations according to performance.

Prior to this work, no systematic analysis had been made of the properties of such a large spectrum of electrical insulations, related to their behavior under thermal flux.

ADDENDUM: CAMI EXECUTIVE SUMMARY OF
DOT/TSC CONTRACT NO. RA-77-15
INHALATION TOXICITY OF THERMAL DEGRADATION
PRODUCTS FROM ELECTRICAL INSULATION

INTRODUCTION

Over the past decade there has been an increased general awareness of the potential toxic hazard associated with the thermal degradation of all polymeric materials. This general concern on the part of industry, the public, and government has fostered considerable research directed toward the evaluation of the relative merits of polymeric materials in current use, as well as toward the manufacture of new materials with improved "fire hazard" properties.

This same period of time has seen an increased growth in the rapid transit industry with correspondingly increased usage of electrical wire and cable insulation material. The industry, therefore, has an immediate and urgent need for reliable test procedures with which the relative, fire-related properties of both old and new insulating materials can be assessed.

The Urban Mass Transportation Administration (UMTA), which now has total program responsibility for safety in the rapid rail transit system, sponsored the research reported in this volume in an effort to insure the least possible delay in providing the information and technology necessary for industry to identify reasonably safe materials.

There are many properties of a material that relate to its performance and potential safety hazard in a fire environment. Investigation of those pertinent properties other than toxicity, and techniques for their measurement, are the subject of Volume I, Electrical Insulation Fire Characteristics, which represents research conducted by the Boeing Commercial Airplane Company, Seattle, Washington, under Contract DOT/TSC-1221. In that study 104 specimens of insulation were evaluated, of which 83 were single-conductor specimens and 21 were multiple-conductor assemblies with representation from both the current-usage and new, state-of-the-art categories.

Fourteen of these subject materials were selected for evaluation of the relative toxic potentials of their volatile thermal degradation products, a potential hazard for passengers in the limited confines of a rapid transit vehicle or subway tunnel. This research was conducted at the Civil Aeromedical Institute, FAA, and is the subject of Electrical Insulation Fire Characteristics, Volume II: Toxicity (Contract No. DOT/TSC/RA 77-15/77-16).

METHOD

Insulation samples were pyrolyzed in a quartz combustion tube through which air from the animal exposure chamber was circulated, forcing the smoke/gases into the chamber and forming a closed system. Male albino rats were confined in circular, motor-driven, rotating cages within the exposure chamber, forcing them to walk in order to maintain an upright position. The elapsed time between initiation of sample pyrolysis and the time when the rat could no longer perform the coordinated act of walking was recorded as observed time-to-incapacitation (Obs t_i). When all rats were incapacitated, cage rotation was stopped and the rats were observed until visible signs of breathing ceased. The elapsed time between pyrolysis initiation and cessation of breathing was recorded as observed time-to-death (Obs t_d). Rats surviving the 30-minute observation period were removed from the exposure chamber and held for 2 weeks to observe any delayed toxic effects.

It is currently impossible to accurately predict how the toxicity of the resultant gas mixture from a given material will vary with different thermal degradation conditions. Therefore, each insulation was decomposed at two temperatures, both of which could be realistically expected to occur in an actual fire, and under flaming and nonflaming conditions. Time-to-incapacitation for the "worst-case" (shortest t_i) thermal condition for each material was selected as the physiological endpoint for ranking the relative toxic potential of the materials. The authors consider ranking on the basis of t_i to be more realistic than ranking by t_d since potential victims in a developing fire situation usually must remove themselves from the fire environment or perish in it. Also, physical incapacitation normally occurs much earlier than death (but with no constant t_d/t_i ratio), and a ranking based on t_d might significantly misrepresent the relative threat posed by the different insulations.

RESULTS

A rank order for all 14 materials, in terms of their relative potential toxicities, and based on equal weights of materials, is shown in Table S-1. This rank order is based on the standard t_i , in minutes, and is arranged in order from rank 1 (least toxic) to rank 14 (most toxic).

Table S-1. Material Rank-Order Based on Worst-Case Performance for Standard t_i

Rank	Material No.	Mean Std t_i *
1	A6-4X12-1 (Sil/Glass Braid)	22.0 [†]
2	1-16-1 (Silicone/PO)	17.9
3	A7-24X19-5 (PE/Al/PVC/Grease)	7.5
4	A1-14-1 (PVC)	7.4
5	A5-00-3 (PE/Cu Shield)	7.4
6	A7-00-2 (EPR/Neoprene)	7.3
7	11-20-1 (Exane)	7.0
8	A2-6/2X19-4 (PE/Cu Shield)	6.9
9	12-20-2 (Teflon)	6.7
10	A5-14-1 (EPR/Hypalon)	6.6
11	A3-7X14-2 (Prop/Cloth/Neoprene)	6.0
12	12-12-4 (Halar)	4.7
13	3-20-1 (Tefzel)	4.5
14	13-16-1 (Kapton)	4.5

*Standard t_i is the observed t_i normalized to a standard rat weight of 200g. Each table value is a mean value for 9 animals.

$t_n = 8$; one animal did not become incapacitated in 30 min.

The standard t_i 's in Table S-1 reflect the potential toxicities for equal weights of the insulation materials and represent the starting points for calculating the end-use relative toxicities when the total weights of the materials in the end-use application are known.

CAUTIONS AND LIMITATIONS

Data in this report were derived by a protocol that has been used to evaluate approximately 200 polymeric materials and the authors have little concern over repeatability of reported results, or interpretations, as applied to this system. At present, however, little scientifically-demonstrated evidence exists indicating that laboratory-scale tests can successfully predict the toxic behavior of a material in a real fire. Test protocols developed by other laboratories have assigned significantly different relative toxicities to the same materials, leading to the inescapable conclusion that caution must always be used in relating data from laboratory tests to any frame of reference other than that from which the data originated. It is especially important to realize that the relative merit assigned to materials by these tests could be entirely different from their relative merit based on behavior in an uncontrolled, full-scale fire.