

UMTA 79-18

REPORT NO. UMTA-MA-06-0100-79-2

# MEASUREMENT PROGRAM FOR EVALUATION OF CONCRETE TIES AND FASTENINGS IN TRANSIT TRACK

**Amir N. Hanna**

CONSTRUCTION TECHNOLOGY LABORATORIES  
A Division of Portland Cement Association  
5420 Old Orchard Road  
Skokie, IL 60077



**MARCH 1979  
FINAL REPORT**

Document is available to the U.S. public through the  
National Technical Information Service,  
Springfield, VA 22161

**Prepared for**  
**U.S. DEPARTMENT OF TRANSPORTATION**  
**URBAN MASS TRANSPORTATION ADMINISTRATION**  
**Office of Technology Development and Deployment**  
**Office of Rail and Construction Technology**  
**Washington, D.C. 20590**

**NOTICE**

This document is disseminated under the sponsorship of the Department of Transportation in the interest of information exchange. The United States Government assumes no liability for its contents or use thereof.

**NOTICE**

The United States Government does not endorse products or manufacturers. Trade or manufacturers' names appear herein solely because they are considered essential to the object of this report.

1. Report No. UMTA-MA-06-0100-79-2		2. Government Accession No.		3. Recipient's Catalog No.	
4. Title and Subtitle Measurement Program for Evaluation of Concrete Ties and Fastenings in Transit Track				5. Report Date March 1979	
				6. Performing Organization Code	
7. Author(s) Amir N. Hanna				8. Performing Organization Report No. DOT-TSC-UMTA-79-18	
9. Performing Organization Name and Address Construction Technology Laboratories* A Division of Portland Cement Association 5420 Old Orchard Road Skokie, IL 60077				10. Work Unit No. (TRAIS) UM 948/R9745	
				11. Contract or Grant No. DOT-TSC-1442	
12. Sponsoring Agency Name and Address U.S. Department of Transportation Urban Mass Transportation Administration Office of Technology Development & Deployment Office of Rail and Construction Technology Washington, D.C. 20590				13. Type of Report and Period Covered Final Report	
				14. Sponsoring Agency Code UTD-30	
15. Supplementary Notes *Under Contract to: U.S. Department of Transportation Research and Special Programs Administration Transportation Systems Center Cambridge, Massachusetts 02142					
16. Abstract This report was prepared as part of an ongoing research effort by the Urban Mass Transportation Administration of the U.S. Department of Transportation to develop standard concrete ties for rapid transit use. The report outlines a measurement program to obtain data on the performance of standard tie designs and associated fastening systems under field service conditions. In addition, the program identifies limited data to be obtained from a wood tie track for comparison.					
17. Key Words Ballast, concrete cross ties, instrumentation, rail fastenings, testing, track, transit				18. Distribution Statement Document is available to the U.S. Public through the National Information Service, Springfield, Virginia 22161	
19. Security Classif. (of this report) Unclassified		20. Security Classif. (of this page) Unclassified		21. No. of Pages 40	22. Price



## PREFACE

This report was prepared by the Construction Technology Laboratories, a division of the Portland Cement Association, under contract No. DOT-TSC-1442 managed by the Transportation Systems Center, Cambridge, Massachusetts. The contract is part of a program sponsored by the Office of Rail and Construction Technology, Office of Technology Development and Deployment, Urban Mass Transportation Administration of the U.S. Department of Transportation to develop standard concrete ties for rapid transit use.

The overall objective of this contract is to fabricate and evaluate, by laboratory tests, standard ties of different designs intended for transit use. The tie designs, a pretensioned monoblock and a post-tensioned two-block, and the preliminary specifications for tie manufacture were developed under an earlier contract from the Transit Development Corporation. This report outlines a measurement program to obtain data on the performance of these standard tie designs and associated fastening systems under field service conditions.

Mr. P. Witkiewicz and Mr. G. Saulnier of the Transportation Systems Center were the technical monitor and alternate technical monitor, respectively, for the work reported herein. Their cooperation and suggestions are gratefully acknowledged. Mr. F. J. Cihak of the American Public Transit Association and representatives of several transit properties also deserve recognition for their assistance and suggestions.

# METRIC CONVERSION FACTORS

Approximate Conversions to Metric Measures				Approximate Conversions from Metric Measures			
Symbol	When You Know	Multiply by	To Find	Symbol	When You Know	Multiply by	To Find
<b>LENGTH</b>							
in	inches	2.5	centimeters	cm	millimeters	0.04	inches
ft	feet	30	centimeters	cm	centimeters	0.4	inches
yd	yards	0.9	meters	m	meters	3.3	feet
mi	miles	1.6	kilometers	km	kilometers	0.6	miles
<b>AREA</b>							
m <sup>2</sup>	square inches	6.5	square centimeters	cm <sup>2</sup>	square centimeters	0.16	square inches
ft <sup>2</sup>	square feet	0.09	square meters	m <sup>2</sup>	square meters	1.2	square yards
yd <sup>2</sup>	square yards	0.8	square meters	m <sup>2</sup>	square kilometers	0.4	square miles
mi <sup>2</sup>	square miles	2.6	square kilometers	km <sup>2</sup>	hectares (10,000 m <sup>2</sup> )	2.5	square miles
ac	acres	0.4	hectares	ha			
<b>MASS (weight)</b>							
oz	ounces	28	grams	g	grams	0.035	ounces
lb	pounds	0.45	kilograms	kg	kilograms	2.2	pounds
	short tons (2000 lb)	0.9	tonnes	t	tonnes (1000 kg)	1.1	short tons
<b>VOLUME</b>							
teaspoon	teaspoons	5	milliliters	ml	milliliters	0.03	fluid ounces
Tablespoon	tablespoons	15	milliliters	ml	liters	2.1	pints
fl oz	fluid ounces	30	milliliters	ml	liters	1.06	quarts
c	cup	0.24	liters	l	liters	0.26	gallons
pt	pint	0.47	liters	l	cubic meters	35	cubic feet
qt	quart	0.96	liters	l	cubic meters	1.3	cubic yards
gal	gallon	3.8	liters	m <sup>3</sup>			
cu ft	cubic feet	0.03	cubic meters	m <sup>3</sup>			
cu yd	cubic yards	0.76	cubic meters	m <sup>3</sup>			
<b>TEMPERATURE (exact)</b>							
F	Fahrenheit temperature	5/9 (after subtracting 32)	Celsius temperature	C	Celsius temperature	9/5 (then add 32)	Fahrenheit temperature

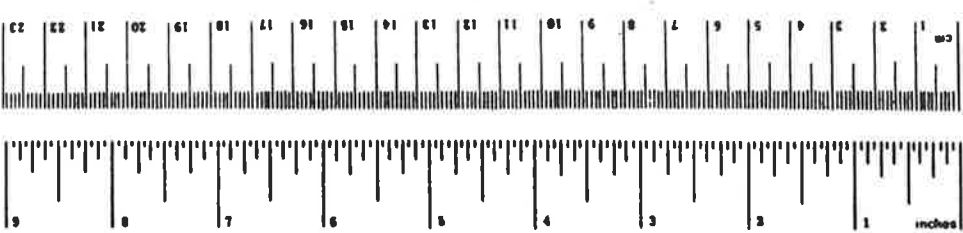

## CONTENTS

<u>Section</u>	<u>Page</u>
1. INTRODUCTION	1
2. TYPE OF DATA FOR EVALUATION OF TRACK PERFORMANCE	2
2.1 Structural Values	2
2.1.1 Rail Data	2
2.1.2 Cross Tie Data	3
2.1.3 Ballast Data	3
2.1.4 Subgrade Data	3
2.2 Long-Term Changes	3
3. TRACK INSTRUMENTATION	5
3.1 Measurement of Structural Values	5
3.1.1 Rail Instrumentation	5
3.1.2 Cross Tie Instrumentation	12
3.1.3 Ballast Instrumentation	12
3.2 Measurement of Long-Term Changes	14
4. INSTRUMENTATION AND RECORDING EQUIPMENT	18
5. TEST PLAN AND SCHEDULE	21
5.1 Test Site	21
5.2 Test Plan	22
5.3 Test Schedule	23
6. EVALUATION CRITERIA	27
6.1 Structural Values	27
6.1.1 Rail Criteria	27
6.1.2 Cross Tie Criteria	27
6.1.3 Ballast Criteria	28
6.2 Long-Term Changes	29
7. SUMMARY AND CONCLUDING REMARKS	31
APPENDIX - REPORT OF NEW TECHNOLOGY	33

## LIST OF ILLUSTRATIONS

<u>Figure</u>		<u>Page</u>
3-1	INSTRUMENTATION LAYOUT FOR MONOBLOCK CONCRETE TIE TRACK	6
3-2	LOCATION OF INSTRUMENTATION IN MONOBLOCK CONCRETE TIE TRACK	7
3-3	INSTRUMENTATION LAYOUT FOR TWO-BLOCK CONCRETE TIE TRACK	8
3-4	LOCATION OF INSTRUMENTATION IN TWO-BLOCK CONCRETE TIE TRACK	9
3-5	INSTRUMENTATION LAYOUT FOR WOOD TIE TRACK	10
3-6	LOCATION OF INSTRUMENTATION FOR WOOD TIE TRACK	11
3-7	LOCATION OF STRAIN GAGES ON CROSS TIES	13
3-8	LOCATION OF LONG-TERM CHANGE MEASUREMENTS IN CONCRETE TIE TRACK	15
3-9	LOCATION OF LONG-TERM CHANGE MEASUREMENTS IN WOOD TIE TRACK	16
4-1	INSTRUMENTATION VAN AT A TEST SITE	19
5-1	TENTATIVE PROJECT SCHEDULE	26



LIST OF TABLES

<u>Table</u>		<u>Page</u>
4-1	TYPES OF TRACK INSTRUMENTATION	20
5-1	TEST VARIABLES	24



## 1. INTRODUCTION

This measurement program is prepared as part of an on-going research effort by the Urban Mass Transportation Administration of the U.S. Department of Transportation to develop standard concrete ties for rapid transit use. In this research effort, two tie designs, a pretensioned monoblock and a post-tensioned two-block, and preliminary specifications for tie manufacture were prepared. Also, ties of the two designs were fabricated and laboratory tested under a contract managed by the Transportation Systems Center. As a result of the laboratory testing program, the preliminary specifications were modified. However, information is required on the performance of track components under field operating conditions to verify the adequacy of the design and specifications.

The primary objective of this measurement program is to obtain data on the response of standard transit concrete ties and fasteners to field operating transit loads. In addition, limited data will be obtained from a wood tie track section for comparison. This will be accomplished by instrumenting track sections with sensing devices to record long-term changes in track geometry and to measure periodically the dynamic response of track components to train loads. Analysis of data collected from this instrumentation will be used to (a) assess long-term performance of standard concrete ties and fastenings and (b) evaluate the adequacy of designs and preliminary specifications prepared in an earlier research effort.

To describe the measurement program, the following items will be discussed:

- a. Type of data to be collected,
- b. Type of instrumentation to be installed and its location in track,
- c. Type of equipment required for data acquisition,
- d. Test schedule, and
- e. Criteria for evaluating test data.

## 2. TYPE OF DATA FOR EVALUATION OF TRACK PERFORMANCE

Dynamic response of track to traffic is measured in terms of structural values such as deflections, strains, and pressures. These structural values are obtained from sensing devices installed in track.

Long-term changes in track structure are measured in terms of factors that could lead to track deterioration such as gage widening, permanent deformation or settlement, and alignment variation. These values are obtained when the track is in an unloaded condition.

### 2.1 STRUCTURAL VALUES

The evaluation of track behavior in terms of factors that lead to distress requires the measurement of structural track response to traffic. Since track response depends on train loads and speed, it is recommended that trains of different known weights be used for test runs. In this manner, test data can be used to estimate the effect of other train loads. Principal data to be obtained from the test installation are summarized.

#### 2.1.1 Rail Data

The effect of traffic loads and speed of operation on rail response may be determined from rail strains or deflections.

Strains measured at critical locations of the rail cross section can be used to establish maximum rail bending stresses. However, as rail bending stresses are not greatly influenced by the type of tie or fastening system, measurements of rail stresses are not significant to the evaluation. Therefore, vertical rail deflections will be used to evaluate the effect of traffic, environment, and maintenance on track rigidity.

### 2.1.2 Cross Tie Data

The effect of traffic loads and speed of operation on cross tie behavior is determined from tie strains and deflections.

Tie strains at the critical cross sections will be used to establish the strength level of the tie, and to determine the level of safety against flexural cracking. Vertical tie deflections will be used to evaluate the effect of traffic, environment, and maintenance on stiffness and stability of ballast and subgrade.

### 2.1.3 Ballast Data

The effect of traffic on ballast behavior is determined from ballast pressure measurements.

Pressure on the ballast directly underneath the tie will be used to establish the level of safety against permanent deformation and crushing of ballast particles. Also, changes in ballast pressure will be used to evaluate the effect of traffic on the development of a center-bound condition.

### 2.1.4 Subgrade Data

The effect of traffic on subgrade behavior is determined from subgrade pressure.

Subgrade pressure at the ballast-subgrade interface underneath the tie and between ties can be used to establish the level of safety against shear failure and excessive permanent deformation. However, as subgrade pressure values are generally small due to load distribution through the ties and ballast, measurements of subgrade pressures will not be necessary.

## 2.2 LONG-TERM CHANGES

The evaluation of track behavior in terms of factors that lead to track deterioration requires the measurement of long-term changes in track structure. These measurements, obtained periodically, can be used to predict track safety and performance of track components. Principal measurements required to

evaluate long-term changes in track structure include the following:

- a. Track gage that indicates widening.
- b. Track geometry that indicates changes in alignment, surface, and cross level.
- c. Permanent deformation that indicates permanent changes in elevation of rail, tie, ballast, and subgrade.
- d. Rail creep to evaluate ability of fasteners to restrain longitudinal rail movement.
- e. Lateral and longitudinal tie movements that indicate effectiveness of ballast in restraining lateral and longitudinal movements and thus assuring track stability.
- f. Movement and condition of pads, insulators, and clips that indicate ability of the fastening system to function properly without deterioration.
- g. Loosening of contact rail support bracket anchor bolts.

In addition, measurement of electrical resistance between rails is required to evaluate ability of the fastening system to provide electrical insulation.

Data on noise and vibration characteristics produced by rolling stock on different track systems have been obtained from several field installations. Therefore, measurement of these data is not included in this program.

### 3. TRACK INSTRUMENTATION

Evaluation of track response to traffic and environment requires measurement of structural response of track components and long-term changes in track structure. This will be accomplished using sensing devices and measuring techniques to obtain the type of data required for evaluation of track performance.

#### 3.1 MEASUREMENT OF STRUCTURAL VALUES

To obtain the response of track to traffic in terms of structural values, concrete tie track sections will be instrumented with appropriate sensing devices. In addition, limited instrumentation will be installed in a wood tie track section to provide data for comparison. Descriptions of the instrumentation and their location in track is shown in Figures 3-1 and 3-2 for monoblock concrete tie track, in Figures 3-3 and 3-4 for two-block concrete tie track, and in Figures 3-5 and 3-6 for a wood tie track. In addition, methods of installation are described.

##### 3.1.1 Rail Instrumentation

To measure rail deflections, electrical transformers known as LVDT's (linear variable differential transformers) will be used. The LVDT's will be attached to the rail and the stem will be seated on a reference rod. As shown in Figures 3-2, 3-4, and 3-6, rail deflections will be measured near the fasteners.

Reference rods will be driven through casings into the subgrade. Ideally, a 1-1/4-in. diameter hole is drilled to a depth of 10 ft. A pipe of the same diameter is then forced into the hole. A 1/2-in. diameter, 13-ft long steel rod is then inserted in the pipe and driven 3 ft into the subgrade. In the event rock is encountered at less than 13-ft depth, the rod will be firmly anchored in the rock. For installations in frost areas, the casing should be filled with grease.

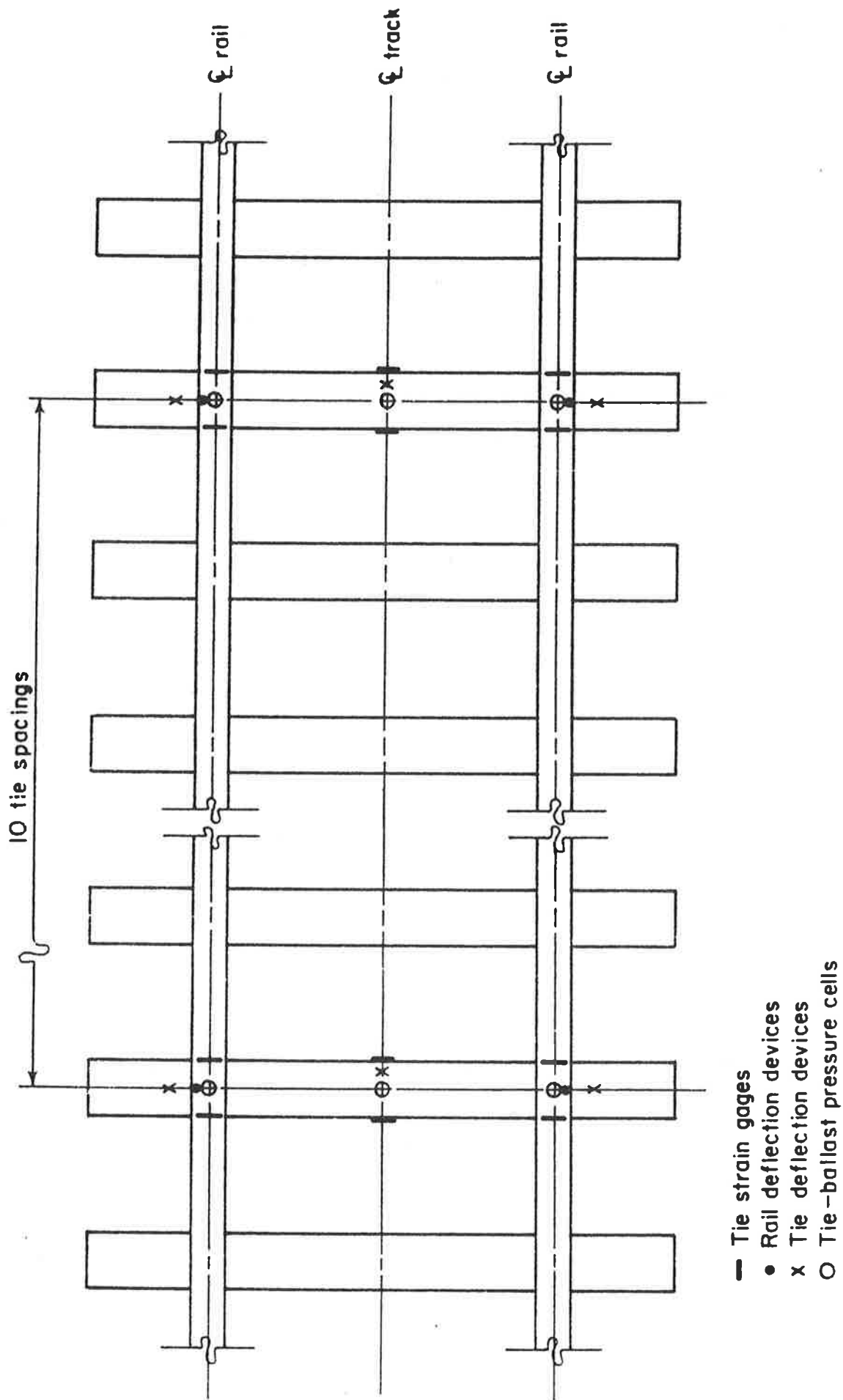
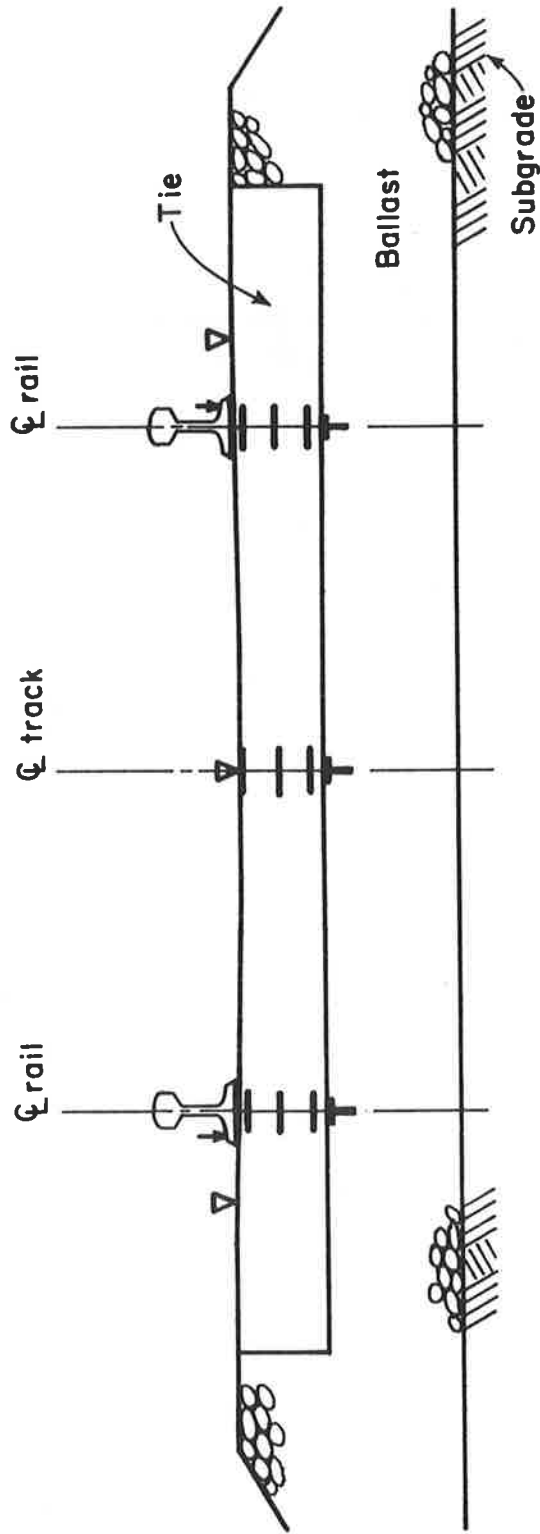

FIGURE 3-1. INSTRUMENTATION LAYOUT FOR MONOBLOCK CONCRETE TIE TRACK





- Tie strain gages
- T Tie -ballast pressure cells
- ↓ Rail deflection devices
- ▽ Tie deflection devices

FIGURE 3-2. LOCATION OF INSTRUMENTATION IN MONOBLOCK CONCRETE TIE TRACK

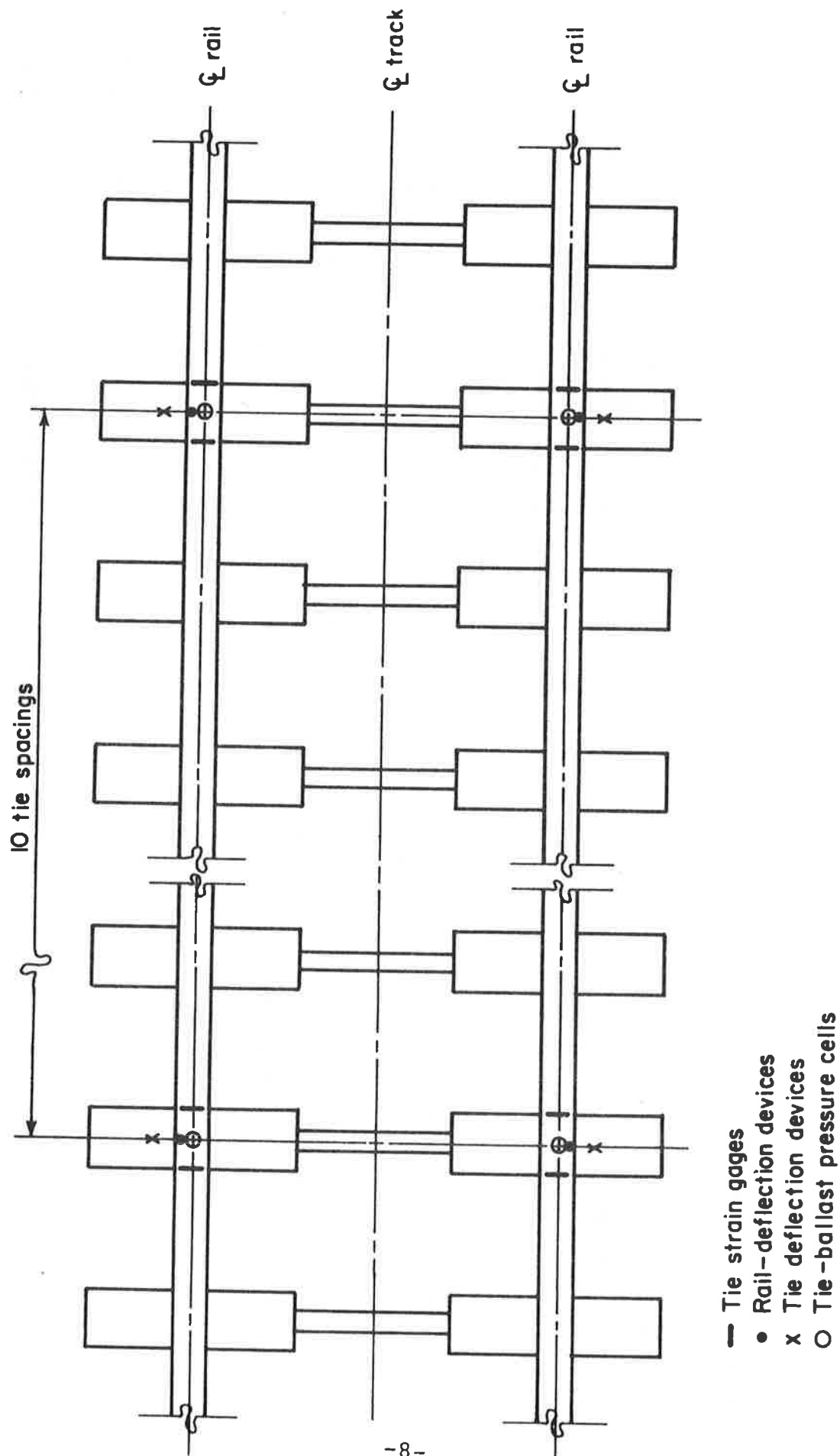

FIGURE 3-3. INSTRUMENTATION LAYOUT FOR TWO-BLOCK CONCRETE TIE TRACK

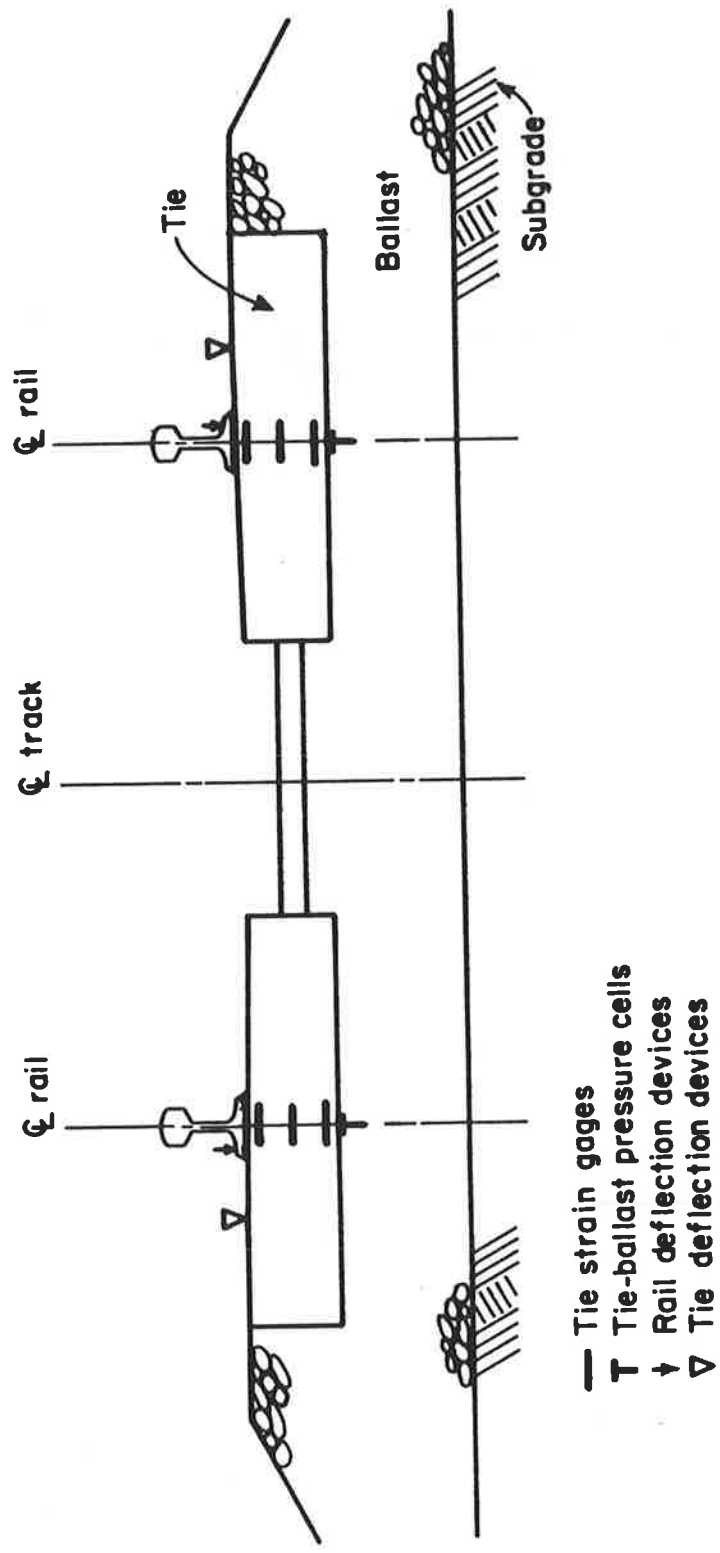
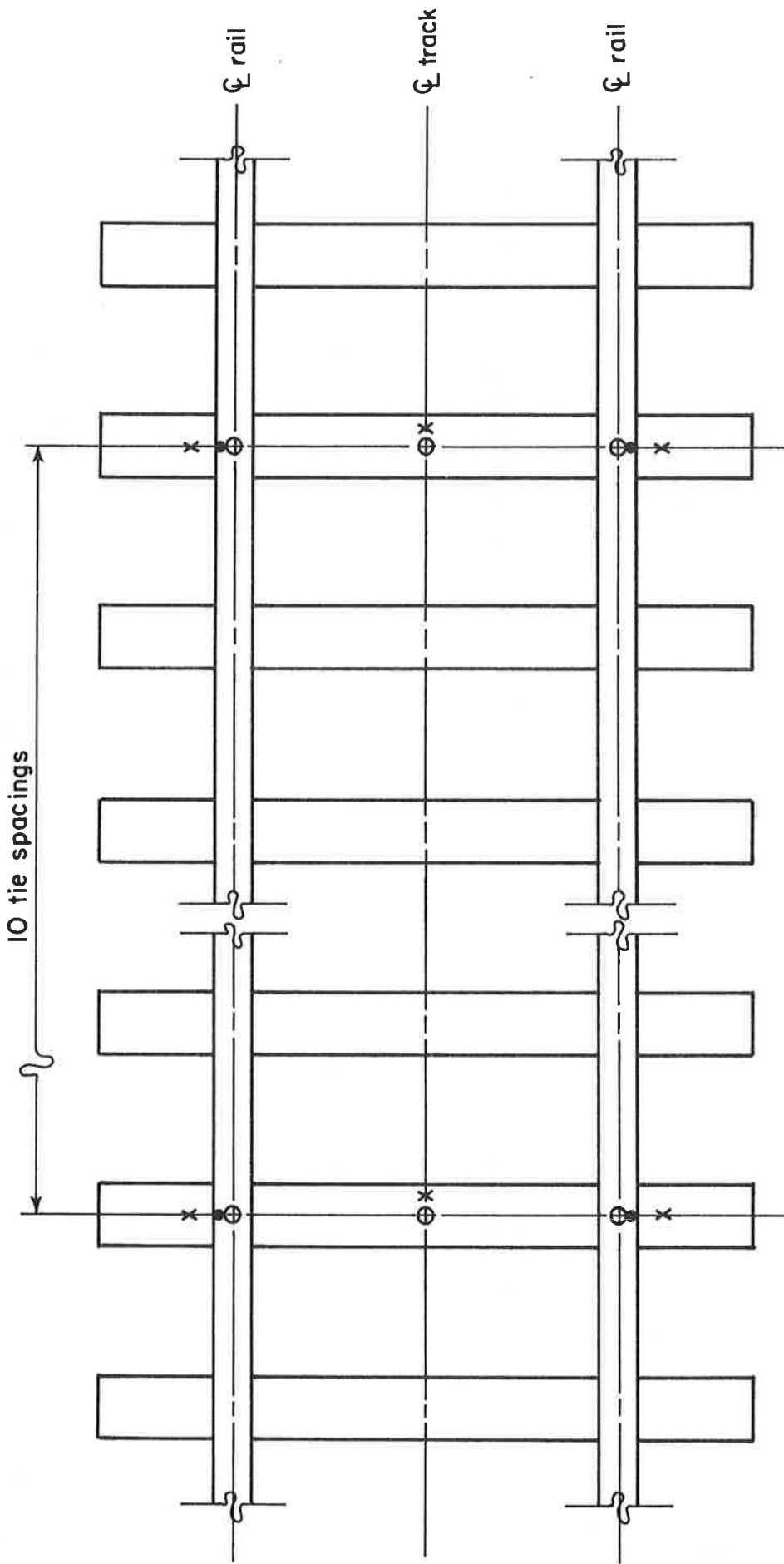
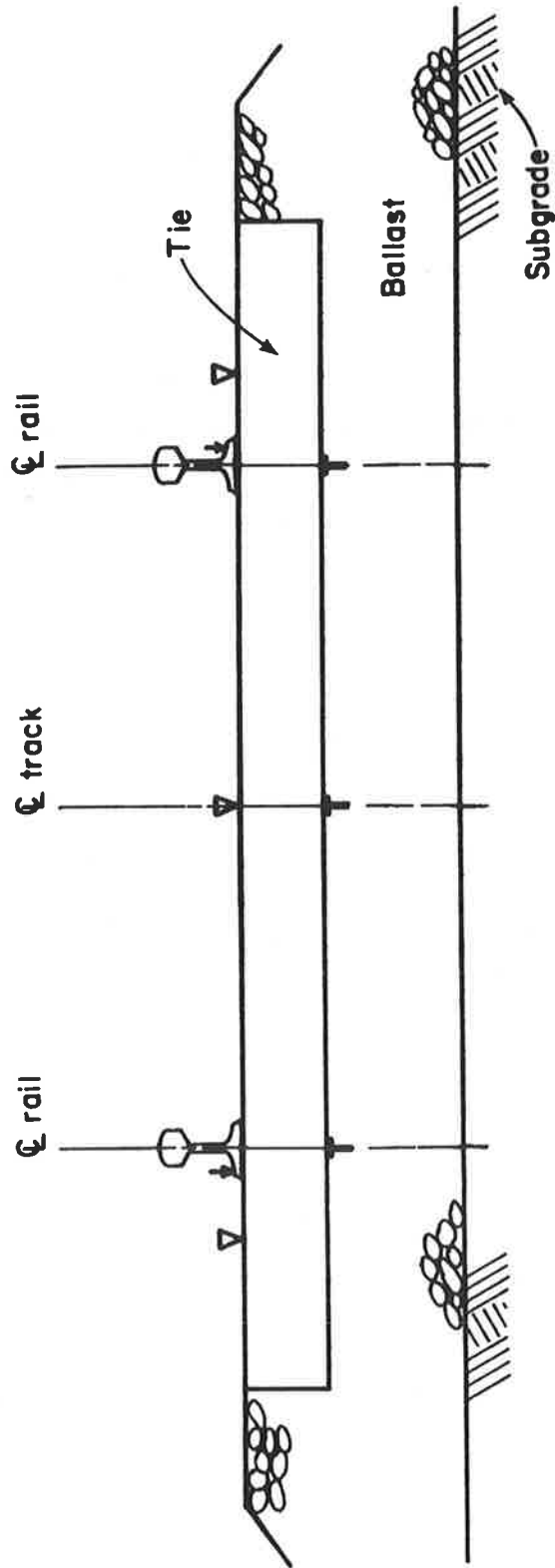

FIGURE 3-4. LOCATION OF INSTRUMENTATION IN TWO-BLOCK CONCRETE TIE TRACK



- Rail deflection devices
- x Tie deflection devices
- ⊗ Tie-ballast pressure cells

FIGURE 3-5. INSTRUMENTATION LAYOUT FOR WOOD TIE TRACK



- T** Tie-ballast pressure cells
- ↓** Rail deflection devices
- ▽** Tie deflection devices

FIGURE 3-6. LOCATION OF INSTRUMENTATION FOR WOOD TIE TRACK

### 3.1.2 Cross Tie Instrumentation

Two types of sensing devices are required to obtain tie data. These are strain gages and displacement transducers.

Strain gages will be used to measure longitudinal strains in the concrete at critical locations. For monoblock ties, strain gages will be cemented at sections located directly below the rail base and at midlength as shown in Figure 3-2. However, for two-block ties, strain gages will be cemented only at sections below the rail seats as shown in Figure 3-4. For accuracy of data, strain gages with a gage length of at least 3-times the maximum aggregate size will be used. Prior to cementing the gages, concrete surfaces will be smoothed and cleaned. Only cements recommended by the strain gage manufacturer or suitable epoxy resin cements will be used. Locations of strain gages on a monoblock tie and a two-block tie are shown in Figure 3-7.

Deflections of the tie will be measured using displacement transducers. The transducers will be attached to the top surface of the tie and installed in a manner similar to that described for rail measurements. The measurements will be taken near the fasteners and at track centerline for monoblock concrete and wood tie track sections, as shown in Figures 3-2 and 3-6, but only near the fasteners for the two-block concrete tie track, as shown in Figure 3-4.

### 3.1.3 Ballast Instrumentation

To obtain ballast response to traffic, pressure cells will be used. Pressure cells will be placed at tie-ballast interfaces directly under the fasteners and at track centerline for monoblock concrete and wood tie track sections, as shown in Figures 3-2 and 3-6, and only under the fasteners for two-block concrete tie track, as shown in Figure 3-4.

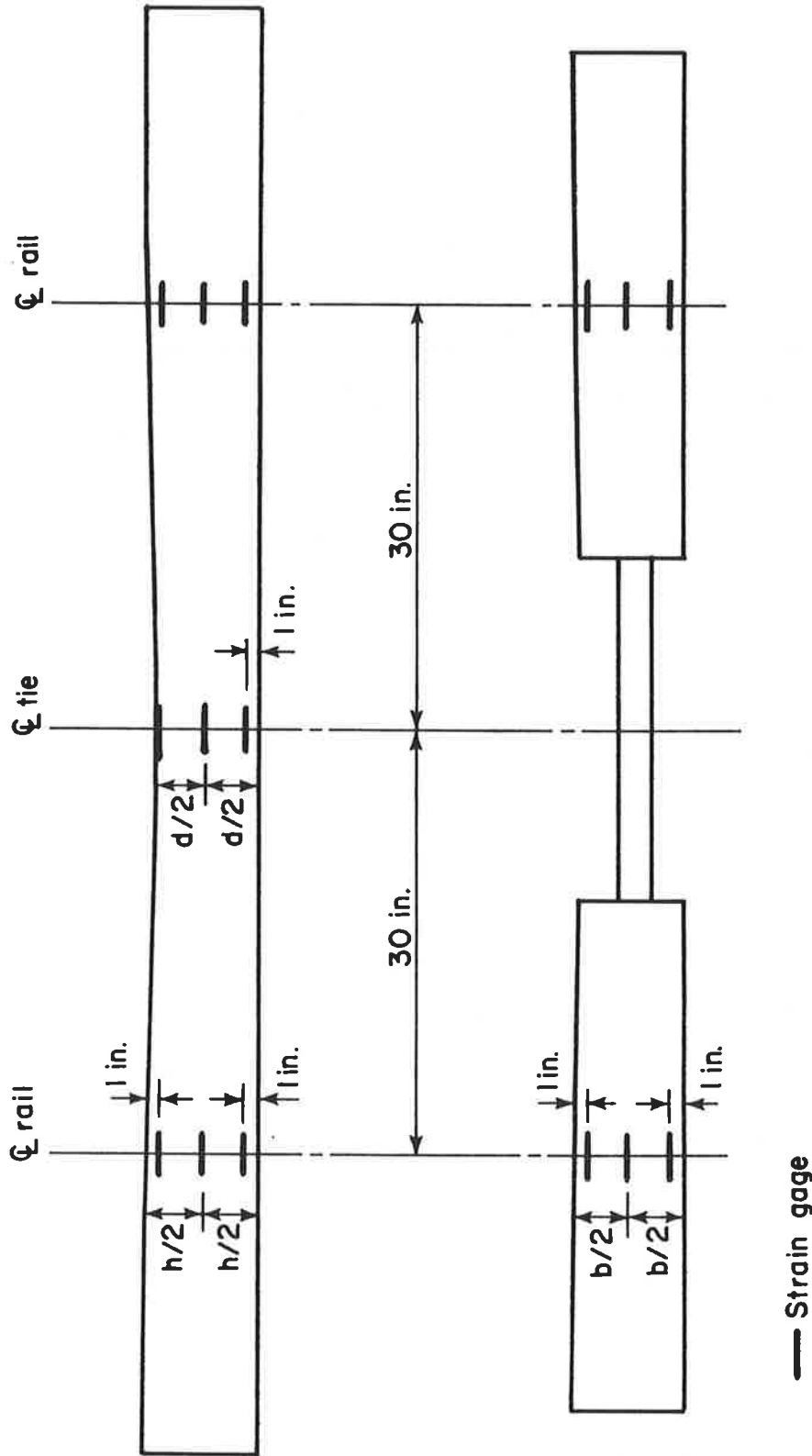

FIGURE 3-7. LOCATION OF STRAIN GAGES ON CROSS TIES

### 3.2 MEASUREMENT OF LONG-TERM CHANGES

To obtain long-term changes in track structure, measurements will be made on concrete tie track sections of changes in track gage, track geometry, cross level, and permanent deformation as well as of position and condition of rail, tie, and fastening components. In addition, limited measurements will be made on a wood tie track section for comparison.

Manual methods will be used to obtain the data required on long-term changes in track structure. These methods require the use of precise optical surveying equipment. No special instrumentation is required. However, reference points and benchmarks will be installed to establish elevation and alignment changes and track movements. Locations of these measurements are shown in Figures 3-8 and 3-9 for the concrete tie and wood tie tracks, respectively.

As Figures 3-8 and 3-9 indicate, changes in track gage, alignment, surface, cross level, and permanent deformation will be measured for both concrete and wood tie tracks. However, measurement of position and condition of rail, tie, and fastening components as well as electrical resistance will be made for concrete tie tracks only.

Track gage will be measured between the heads of the rails at right angles to the rails in a plane  $5/8$ -in. below the top of the rail head.

Alignment will be measured by the deviation of the mid-point from a 62-ft line. The ends of the line must be at points on the gage side of the line rail,  $5/8$ -in. below the top of the rail head. The outside rail on tangent track and the high rail on curves will be used as the line rail.

Track surface will be measured by the deviation from uniform profile on either rail at the mid ordinate of 62-ft chord.

Variation in cross level will be measured by the change in elevation between any two points less than 62-ft apart.

Permanent deformation of track will be measured by the change in elevation of reference points on top of tie near the rail seat area and at tie center.



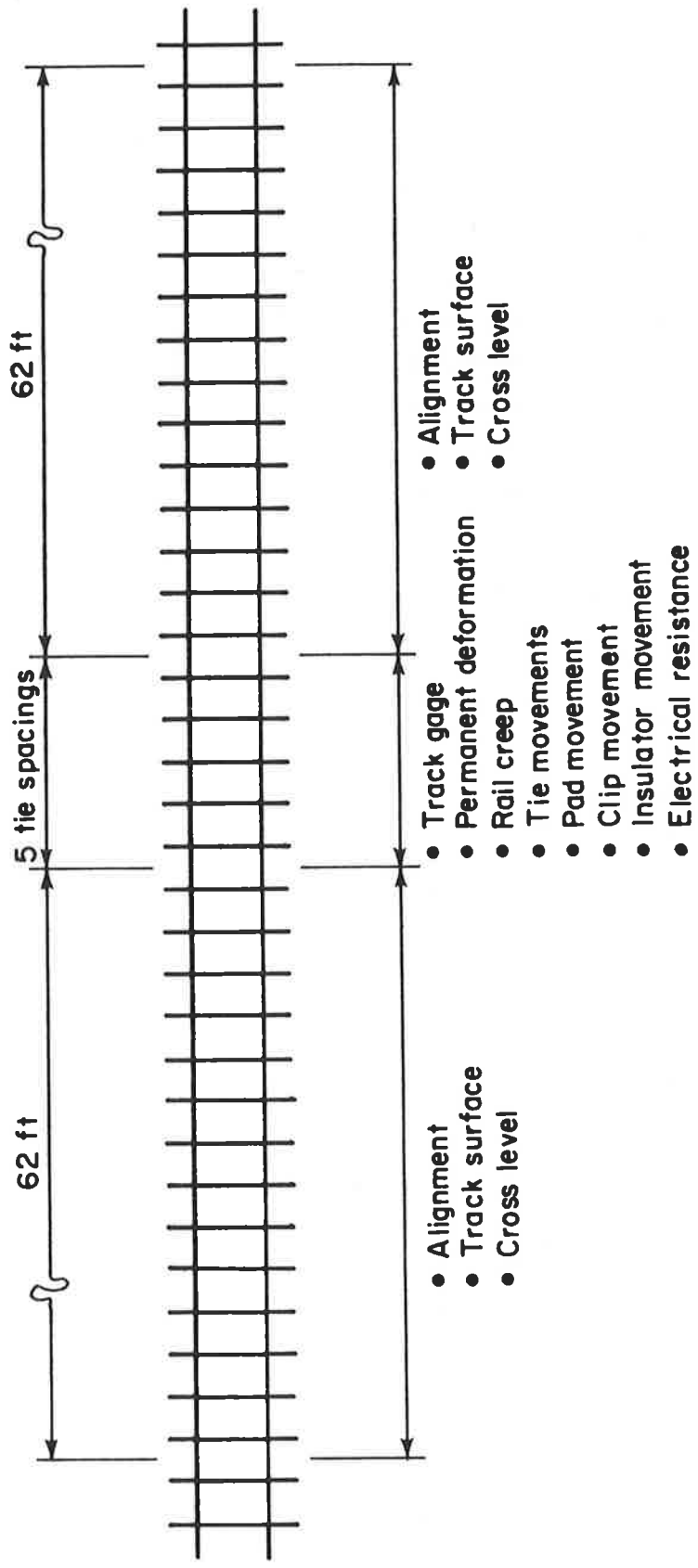

FIGURE 3-8. LOCATION OF LONG-TERM CHANGE MEASUREMENTS IN CONCRETE TIE TRACK

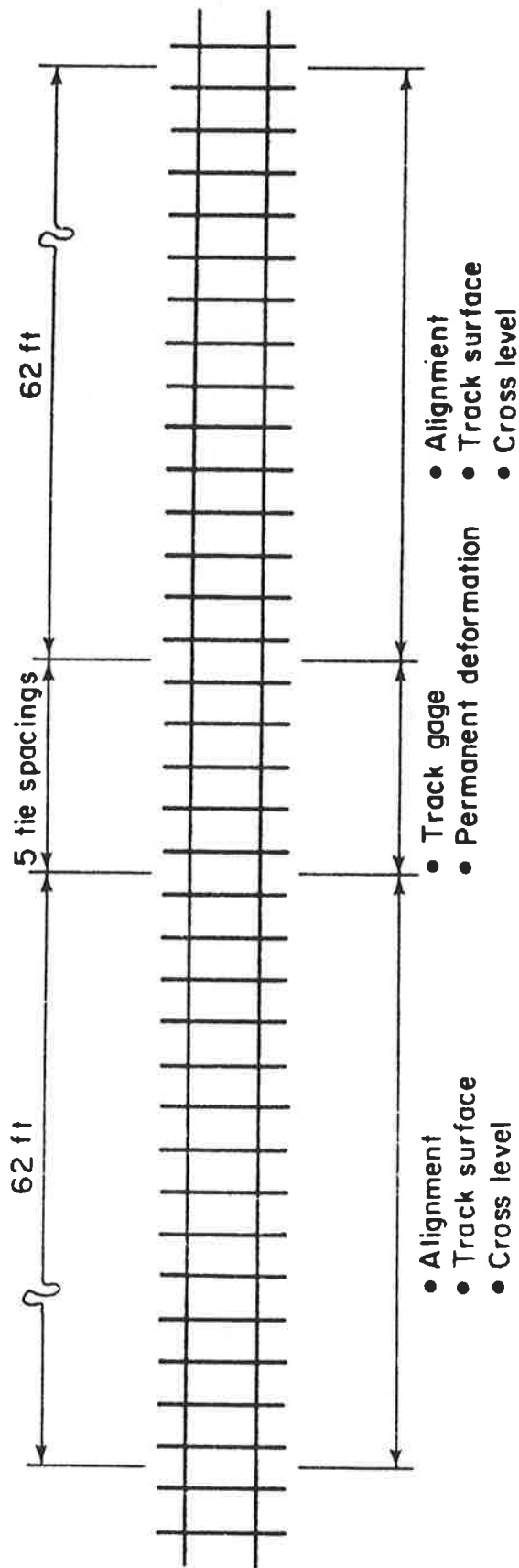

FIGURE 3-9. LOCATION OF LONG-TERM CHANGE MEASUREMENTS IN WOOD TIE TRACK

Rail creep and longitudinal tie movement will be measured with respect to a fixed line perpendicular to the track axis. However, lateral tie movement will be measured with respect to a fixed line parallel to track axis. Each fixed line will be established by two benchmarks.

Pad movement will be measured relative to two points on the tie. Clip movement will be measured relative to the inserts. Insulator movement will be measured relative to the rail.

Electrical resistance will be measured between rails. For this reason, insulated joints should be installed at both ends of each test section. Thus, electrical resistance per unit length of track can be measured. For these measurements, a battery will be used to apply D-C current to the rails. Current flow between the rails will be measured using a D-C ammeter. Electrical impedance will be calculated from applied voltage and measured current flow.

#### 4. INSTRUMENTATION AND RECORDING EQUIPMENT

Several types of measuring and recording equipment may be used in this project. These will include the following:

- a. Oscillographic recorders that produce a permanent trace on paper,
- b. Magnetic tape recorders,
- c. Precise surveying equipment,
- d. Mechanical length change indicators,
- e. A D-C power source such as a 10-volt battery, and
- f. D-C ammeters.

The recording equipment will be housed in an air conditioned van stationed near the test site during the testing period. A view of an instrumentation van at a test site is shown in Figure 4-1.

Sensing devices will be connected to recorders through shielded electrical cables. Box attenuators and zero-balance units will be positioned between the sensors and readout terminals. Cable length will be limited to approximately 200 ft.

Commercially available equipment can be used for instrumentation of track and recording of data. However, some instrumentation accessories such as settlement indicators, reference rods, and settlement monuments will be custom made in the laboratory to fit the selected equipment and instrumentation.

Instrumentation that provides replicate data, as shown in Figures 3-1, 3-3, and 3-5 will be used in each test section. The quantities of each instrumentation type and recording equipment required for each instrumented track section are listed in Table 4-1. The required number of instrumented track sections is discussed in the following section of the report.

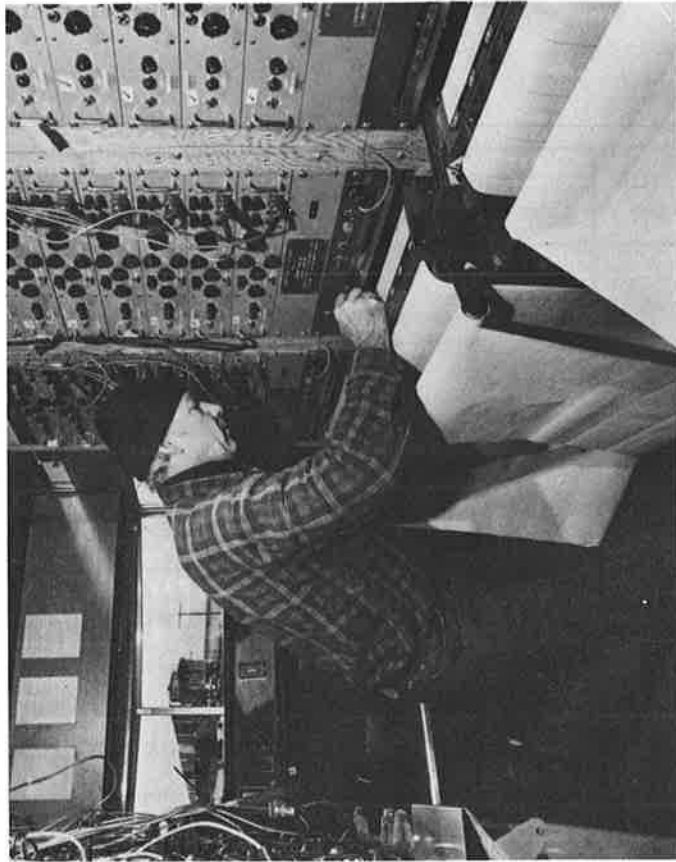

FIGURE 4-1. INSTRUMENTATION VAN AT A TEST SITE

TABLE 4-1. TYPES OF TRACK INSTRUMENTATION

Track Type	Track Component	Instrumentation Type	Number
Monoblock Concrete Tie	Rail	Displacement Transducers	4
	Ties	Strain Gages Displacement Transducers	36 6
	Ballast	Pressure Cells	6
Two-Block Concrete Tie	Rail	Displacement Transducers	4
	Ties	Strain Gages Displacement Transducers	24 4
	Ballast	Pressure Cells	4
Wood Tie	Rail	Displacement Transducers	4
	Ties	Displacement Transducers	6
	Ballast	Pressure Cells	6

## 5. TEST PLAN AND SCHEDULE

To obtain representative data from track instrumentation, consideration will be given to the selection of test site, test plan, and test schedule. These factors are discussed.

### 5.1 TEST SITE

In identifying a test site for track instrumentation, the following factors should be considered:

- a. Track layout parameters such as degree of curve, gradients, and length of tangent,
- b. Operating practices such as speed and braking,
- c. Track structure characteristics such as type of cross ties, type of fastenings, and ballast material and depth, and
- d. Climatic conditions such as frost and rainfall.

In addition, consideration should be given to the constraints imposed by instrumentation and site accessibility.

As the purpose of track instrumentation is to evaluate its performance under critical conditions, the test track site should be selected as follows:

- a. Layout and alignment should permit maximum operating speed,
- b. Track structure should include the different track designs considered for evaluation, and
- c. Climatic conditions at test site should be as severe as prevails in the area. Particular consideration should be given to both rainfall and frost conditions.

If the above conditions are not met in a single test site, compromise should be made in test site selection. This requires study of track alignment, climatic conditions, track structure details, and soil characteristics along the route. However, accessibility of test site should be assured since access for mobile equipment is necessary for data gathering.

Track length of each evaluated design should be sufficient to assure that vehicle behavior, when passing the instrumentation, is not influenced by the preceding track of a different design. Therefore, a minimum length of 750 ft is recommended for each test section with different tie-fastening design. Instrumentation should be placed in the middle portion of test section.

It should be recognized that track layout and operating practices as well as traffic history on all test sections should be as similar as possible. Thus, measured data can be easily compared and evaluated.

## 5.2 TEST PLAN

To evaluate track performance in terms of structural values, instrumentation identified in Figures 3-1 through 3-6 will be used. As these figures indicate, this instrumentation will provide replicate data. Also, similar instrumentation will be used on track sections of different designs. Therefore, for the two concrete tie designs and three fastening systems, to be evaluated in this project, six instrumented concrete tie track sections are required. These will include three monoblock concrete tie track sections each with a different fastening system, and three two-block concrete tie sections each with a different fastening system. In addition, an instrumented wood tie track section is required for comparison. Thus, seven instrumented track sections are required for the evaluation.

Prior to testing, the following work will be performed at each selected test site:

1. Install and calibrate pressure cells,
2. Install deflection reference rods for displacement transducers,
3. Cement external gages on concrete tie surfaces, waterproof, and attach wires,
4. Install junction box terminals and connect all wires, and



5. Check all instrumentation and replace defective ones.

In addition, benchmarks will be installed for measuring long-term changes at each of the seven instrumented track sections. As Figures 3-7 and 3-8 indicate, replicate data will be obtained.

### 5.3 TEST SCHEDULE

To evaluate the effect of traffic volume and environment on track response, data will be obtained during three test periods under operating conditions. During each test period, data will be obtained from each of the seven instrumented track sections. The first testing will be performed immediately prior to or after opening the track to traffic. The second and third testing will be made 4 and 8 months after opening the track to traffic, respectively. Thus, 3 test measurements of each type will be required during the test program.

During each measurement, all sensing devices will be read at three operating conditions:

- a. Standing or slowly operating trains,
- b. Trains operating at maximum speed, and
- c. Trains operating at an intermediate speed

However, to provide replicate data, each test will be repeated for two trains. Thus, a total of 6 train runs are required at each instrumented track section during each test period. Therefore, a total of 42 train runs are required at the seven instrumented track sections for each measurement. Thus, a total of 126 train runs will be required during the entire test program. A summary of test variables is shown in Table 5-1.

When feasible, preweighed trains should be used for test runs. Otherwise, data should be obtained on approximate payload. Thus, effect of train weight on measured data can be properly evaluated.

In addition, long-term change data will be obtained for each of the seven track sections during each test period.

TABLE 5-1. TEST VARIABLES

Track Design and Test Condition		Test Section								
		1	2	3	4	5	6	7		
Track Design	Tie Type	Concrete Monoblock Tie	X	X	X					
		Concrete Two-block Tie				X	X	X		
		Wood Tie							X	
	Fastening System	Fastening Type A	X			X				
		Fastening Type B		X			X			
		Fastening Type C			X			X		
		Tie Plates and Spikes							X	
	Test Condition	Train Speed	Stationary	X	X	X	X	X	X	X
			Intermediate Speed	X	X	X	X	X	X	X
			Maximum Speed	X	X	X	X	X	X	X
Train Run		First Run	X	X	X	X	X	X	X	
		Repeat Run	X	X	X	X	X	X	X	
		Test Period								
Test Period	Initial	X	X	X	X	X	X	X		
	Four Months	X	X	X	X	X	X	X		
	Eight Months	X	X	X	X	X	X	X		

However, special consideration will be made to obtain electrical resistance measurements under critical environmental conditions such as during or immediately following heavy rainfalls.

A tentative project schedule is shown in Figure 5-1.

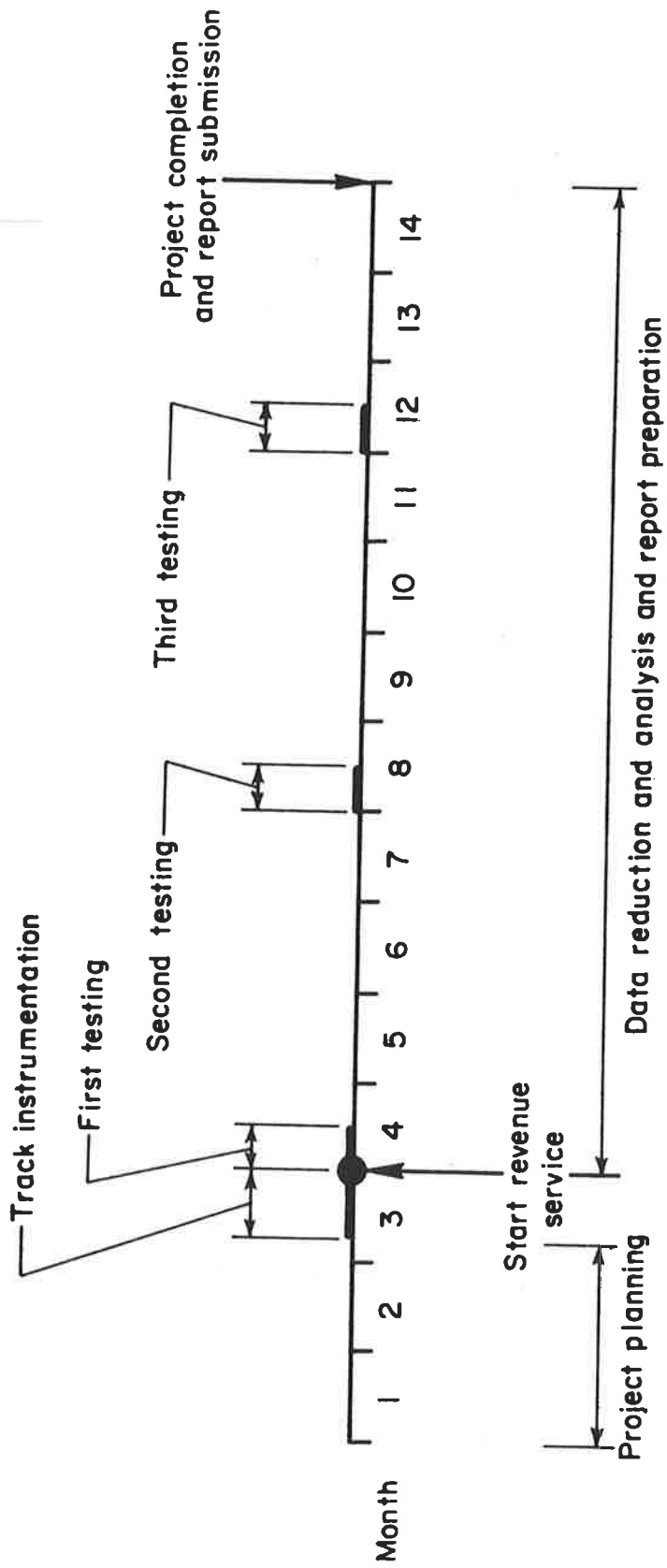

FIGURE 5-1. TENTATIVE PROJECT SCHEDULE

## 6. EVALUATION CRITERIA

Track performance data obtained during the test period will be used to establish track condition and evaluate the adequacy of track components in particular the ties and fasteners. For this purpose, test data will be compared to limiting values to determine whether failure of track components or excessive track deterioration is likely to occur. Evaluation criteria related to structural response values and long-term changes are proposed and methods of evaluation are outlined.

### 6.1 STRUCTURAL VALUES

As described previously, track performance will be determined from structural response values such as stresses, strains, and deformations. Limiting criteria will be selected for these values in a manner such that failure or excessive damage of track components can be avoided. Evaluation criteria for track structural values are proposed.

#### 6.1.1 Rail Criteria

Rail deflection data will be used to evaluate track rigidity that influences track vibrations and ride quality. The change in rail deflection during the test period is an indication of track deterioration. In addition, track deflection values will be used in conjunction with analytical methods to determine track modulus and to predict long-term changes in structural track behavior.

#### 6.1.2 Cross Tie Criteria

Evaluation of tie performance under traffic will be based on tie stresses and deflections.

Tie strains obtained from field measurements during the testing period will be converted to stresses. These stresses and/or strains will be extrapolated to determine values at critical locations of the tie cross sections. For monoblock

ties, stresses at the bottom fiber of the cross sections at rail seat centers and at the top fiber of the cross section at mid-length will be considered. However, for two-block ties, only the stresses at the bottom fiber of the rail seat cross section will be considered.

For evaluation purposes, maximum strains will be compared with those obtained from laboratory tests. In the laboratory tests, similar ties will be supported and loaded in a known manner. The relationship between load and corresponding bending moment and strain will be recorded. Using this calibration, traffic induced bending moments will be calculated from measured strains. These moments will be compared to those that can be carried by the tie without cracking. In the evaluation, consideration will be given to the fatigue behavior of concrete.

Deflections of the tie are related to the rigidity of the track support that consists of ballast and subgrade. The changes in tie deflections during the test period will be used to determine the long-term change in support condition and to evaluate the stability of ballast and subgrade under traffic and environment.

### 6.1.3 Ballast Criteria

Evaluation of ballast performance under traffic will be based on the maximum ballast pressure.

Ballast pressure measured directly under the tie will be compared to the permissible pressure. Permissible pressure values depend on ballast quality and gradation and, therefore, may be determined from laboratory tests. A limiting criteria will be selected for determining whether excessive degradation and permanent deformation of the ballast is likely to occur under the effect of repeated loads. In addition, changes in ballast pressure during the test program will be used to evaluate the probability of development of center-bound condition.

## 6.2 LONG-TERM CHANGES

As described previously, track performance will be measured in terms of long-term changes in track gage, track geometry, cross level, permanent deformation, and track movements.

Excessive variation in track gage would cause the wheels to drop off the rails or push the rails apart. When track gage differs only slightly from standard, and especially if the difference itself varies, smooth riding track can not be achieved. In addition, improper track gage causes cumulative gage widening and increases wear of rails.

Track out of line is equivalent to a series of curves, mostly reverse, that under the effect of traffic become worse. Experience has shown that any faults in alignment, even though minor initially, tend to become greater under the dynamic influence of vehicles. Therefore, alignment quality of track that is repeatedly and effectively straightened will remain largely unchanged. The dynamic action of rolling stock on a misaligned track tends to widen gage until there is danger of rails being overturned or of the track spreading.

Excessive variation in track surface causes a rough ride. In addition, poor surface causes dynamic loads that result in extensive damage or wear and tear to the vehicle and track components.

Faults in cross levels of rails influence wheel load fluctuations and also cause unpleasant shaking of the vehicles. Such vibrations will result in detrimental effect on the vehicles and poor ride quality.

Changes in track gage, alignment, surface and cross levels, obtained during test period, will be compared to reasonable values. Thus, analysis can be made to determine the long-term performance of each track system.

Longitudinal movement of the rail relative to the tie indicates the ability of the fasteners to restrain longitudinal movements. Also, lateral movement of the tie relative to the ballast indicates the effectiveness of the ballast to restrain such movements. Changes in these values during the test period

will be used to assess the long-term performance of the fasteners and the suitability of ballast material.

Movement of pads, insulators, and clips during the test period will be used to assess the long-term performance of the individual fastener components.

Electrical resistance data will be used to assess the ability of each tie-fastening system to provide adequate electrical insulation.

Data on dynamic response of track to traffic and long-term changes in track structure obtained during the test period will be used to accomplish the following:

1. Evaluate the adequacy of track components to carry traffic loads safely.
2. Evaluate the adequacy of the track structure to maintain changes in gage, alignment and surface within reasonable limits to assure good riding quality.

These data will be used to evaluate the adequacy of the preliminary specifications for standard transit concrete ties and fastenings, developed in earlier work items, and to develop final specifications.



## 7. SUMMARY AND CONCLUDING REMARKS

Recommendations are presented for a measurement program for monitoring, over an extended duration, the performance of different cross tie track systems under typical transit conditions. The following topics have been discussed:

- a. Type of data to be collected,
- b. Type of instrumentation to be installed and its location in track,
- c. Type of equipment required for data acquisition,
- d. Test schedule, and
- e. Criteria for evaluating test data.

The recommendations presented in this report are applicable to wood and concrete cross-tie track systems. However, details of track design, traffic pattern, environment, and site topography may place constraints on instrumentation plans or test schedule. In addition, selection of types of recording equipment and sensing devices may be influenced by availability. Therefore, it is recommended that the instrumentation layout as well as the test schedule be reviewed and modified as necessary after track details and test sites have been identified. Also, further modifications of the test plan may be required during implementation of the test program.



## APPENDIX - REPORT OF NEW TECHNOLOGY

This report presents recommendations for a measurement program to obtain data on the performance of different tie designs and associated fastenings under field service conditions. A careful review of the work performed under this contract indicates that no discoveries or inventions have been made. However, the work discusses data, instrumentation, equipment, and criteria required for evaluation of track systems.

Implementation of this program will yield data necessary for the development of standard concrete tie and fastening designs that will assure a quality product and good performance.





