

USCG-78-11. III
REPORT NO. CG-D-55-78

OFFSHORE VESSEL TRAFFIC MANAGEMENT (OVTM) STUDY Volume III — Appendixes

U.S. DEPARTMENT OF TRANSPORTATION
RESEARCH AND SPECIAL PROGRAMS ADMINISTRATION
Transportation Systems Center
Cambridge MA 02142



AUGUST 1978
FINAL REPORT

DOCUMENT IS AVAILABLE TO THE U.S. PUBLIC
THROUGH THE NATIONAL TECHNICAL
INFORMATION SERVICE, SPRINGFIELD,
VIRGINIA 22161

Prepared for
U.S. DEPARTMENT OF TRANSPORTATION
UNITED STATES COAST GUARD
Office of Marine Environment and Systems
Washington DC 20590

NOTICE

This technical study examines traffic management alternatives as a means to reduce or eliminate casualties contributing to pollution of the marine environment. Nothing contained in this report should be construed as affecting or changing the Administration's position on offshore claims in general or at the Third United Nations Conference on the Law of the Sea in particular.

NOTICE

This document is disseminated under the sponsorship of the U.S. Department of Transportation in the interest of information exchange. The United States Government assumes no liability for its contents or use thereof.

NOTICE

The United States Government does not endorse products or manufacturers. Trade or manufacturers' names appear herein solely because they are considered essential to the objectives of this report.

1. Report No. CG-D-55-78		2. Government Accession No.		3. Recipient's Catalog No.	
4. Title and Subtitle OFFSHORE VESSEL TRAFFIC MANAGEMENT (OVTM) STUDY Volume III - Appendixes				5. Report Date August 1978	
				6. Performing Organization Code	
7. Author(s) R. Bland, R. Kalafus, R. Wisleder, et al.*				8. Performing Organization Report No. DOT-TSC-CG-78-11, III	
9. Performing Organization Name and Address U.S. Department of Transportation Research and Special Programs Administration Transportation Systems Center Cambridge MA 02142				10. Work Unit No. (TRAIS) CG816/R8007	
				11. Contract or Grant No.	
12. Sponsoring Agency Name and Address U.S. Department of Transportation United States Coast Guard Office of Marine Environment and Systems Washington DC 20590				13. Type of Report and Period Covered Final Report Aug. 1977 to June 1978	
				14. Sponsoring Agency Code	
15. Supplementary Notes *F. Frankel, D. Prerau, S. Protopapa, D. Glater, J. LoVecchio, and R. Wiseman					
16. Abstract <p>The objectives of the study were: (1) to analyze the causes of tanker and other vessel casualties that could potentially result in oil pollution, and (2) to evaluate various alternative vessel traffic management systems and techniques for the prevention of oil-polluting casualties in the U.S. offshore waters. The geographical areas of interest are the waters from the U.S. coast out to 200 NM around the contiguous 48 states, Hawaii, Puerto Rico, the Virgin Islands and Alaska, except the area north of the Aleutian Islands. Three types of casualties are addressed in the study: groundings, collisions, and rammings. Vessels included in the study are tank vessels (tankers and tank-barges) over 1000 gross tons.</p> <p>The analysis of the causes of tank vessel casualties is performed mainly with the Coast Guard Merchant Vessel Casualty Report (MVCR) data base covering the period from July 1971 to October 1977. Other data sources surveyed include: the Lloyd's Weekly Casualty Reports, the Tanker Casualty Library of Marine Management Systems, Inc., and the Coast Guard Pollution Incident Reporting System. The nature and characteristics of tank vessel casualties that occur in the U.S. offshore waters are described. Systems and techniques considered as alternatives for preventing these casualties are identified, evaluated against each casualty and given an overall rating of casualty prevention effectiveness based on criteria which are defined. The promising systems are selected and conceptual descriptions are presented including the operational features, technical description, cost, staffing and training required, and legal implementation considerations.</p> <p>The report is organized in three volumes: Volume I -- Executive Summary, Volume II -- Technical Analyses, and Volume III -- Appendixes.</p>					
17. Key Words Vessel Traffic Management, Tanker, Tank-Barge, Oil Pollution, Oil Imports, Vessel Collisions, Groundings, Strandings, Argo Merchant, Oil Spills, Rammings				18. Distribution Statement DOCUMENT IS AVAILABLE TO THE U.S. PUBLIC THROUGH THE NATIONAL TECHNICAL INFORMATION SERVICE, SPRINGFIELD, VIRGINIA 22161	
19. Security Classif. (of this report) Unclassified		20. Security Classif. (of this page) Unclassified		21. No. of Pages 278	22. Price

PREFACE

The Offshore Vessel Traffic Management (OVTM) Study was performed in response to Presidential Initiatives issued in March 1977 which were a result of the Argo Merchant oil spill and several other tanker casualties that occurred in the U.S. offshore waters during the winter of 1976-77. These initiatives called for the Secretary, U.S. Department of Transportation, to perform several studies and take other actions to prevent or reduce the effects of oil spills from tank vessel casualties in the U.S. offshore waters. The OVTM Study was referred to in the Presidential Initiatives as "a study of long range vessel surveillance and control systems." The Transportation Systems Center performed this work in support of the U.S. Coast Guard and the Office of the Secretary of Transportation. The study effort was initiated in August 1977 and completed in June 1978.

This study was directed by the Coast Guard Port Safety and Law Enforcement Division with specific guidance by the following individuals: CAPT Richard A. Bauman, USCG; CDR Eugene J. Hickey, USCG; Mr. Don Ryan, and LCDR John Bannan, USCG. Special recognition is given to the Coast Guard Project Manager, Don Ryan, for his many helpful contributions to, and close association with, the TSC study team. Other contributors were: CAPT (Ret. USCG) Harold Lynch, CAPT Arthur Knight and CAPT William Mitchell, all of the Boston Marine Society; John Devanney of the Massachusetts Institute of Technology Center for Transportation Studies; and Patricia Concannon and Jeanette Collier of TSC.

METRIC CONVERSION FACTORS

Approximate Conversions to Metric Measures

Symbol When You Know Multiply by To Find Symbol

LENGTH

in 2.5
ft 30
yd 0.9
mi 1.6

cm
m
km

AREA

in² 6.5
ft² 0.09
yd² 0.8
mi² 2.6
acres 0.4

square centimeters
square meters
square kilometers
hectares

MASS (weight)

oz 28
lb (2000 lb) 0.45
short tons 0.9

grams
kilograms
tonnes

VOLUME

teaspoons 5
tablespoons 15
fluid ounces 30
cups 0.24
pints 0.47
quarts 0.95
gallons 3.8
cubic feet 0.03
cubic yards 0.76

milliliters
liters
cubic meters
cubic meters

TEMPERATURE (exact)

°F Fahrenheit temperature 5/9 (after subtracting 32)

°C Celsius temperature

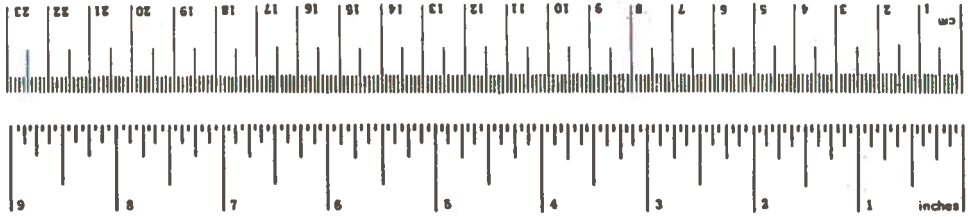

Approximate Conversions from Metric Measures

Symbol When You Know Multiply by To Find Symbol

LENGTH

mm 0.04
cm 0.4
m 3.3
km 0.6

inches
inches
feet
yards
miles

AREA

cm²
m²
km²
ha

square centimeters
square meters
square kilometers
hectares (10,000 m²)
acres

MASS (weight)

g 0.035
kg 2.2
t 1.1

ounces
pounds
short tons

VOLUME

ml 0.03
l 2.1
L 1.06
m³ 0.26
m³ 35
m³ 1.3

fluid ounces
pints
quarts
gallons
cubic feet
cubic yards

TEMPERATURE (exact)

°C Celsius temperature 9/5 (then add 32)

°F Fahrenheit temperature

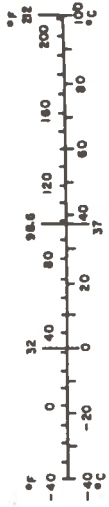

TABLE OF CONTENTS
VOLUME III

<u>Section</u>	<u>Page</u>
APPENDIX A - EXAMPLES OF MERCHANT VESSEL CASUALTY REPORTS.....	A-1
APPENDIX B - MERCHANT VESSEL CASUALTY COMPUTERIZED DATA BASE.....	B-1
APPENDIX C - INDEX AND LISTING OF THE DATA BASE CASES.....	C-1
APPENDIX D - VESSEL TRAFFIC SERVICES.....	D-1
APPENDIX E - EASTERN CANADA TRAFFIC REGULATION.....	E-1
APPENDIX F - THE LORAN-C SYSTEM AND APPLICATIONS TO THE OVTM STUDY.....	F-1
APPENDIX G - SHORE-BASED SYSTEM DESIGN CONSIDERATIONS.....	G-1
APPENDIX H - SATELLITES FOR OFFSHORE VESSEL TRAFFIC MANAGEMENT.....	H-1
APPENDIX I - EVALUATION OF OPERATIONAL FEATURES AND SYSTEMS.....	I-1

LIST OF ILLUSTRATIONS
VOLUME III

<u>Figure</u>		<u>Page</u>
E-1	Eastern Canada Traffic Zone.....	E-4
F-1	U.S. LORAN-C Coverage	F-3
F-2	Pacific Area LORAN-C Coverage	F-4
F-3	North Atlantic and Mediterranean LORAN-C Coverage	F-5
F-4	Planned U.S. LORAN-C Coverage	F-7
G-1	Communication Channel Capacity as a Function of Update Rate.....	G-18
G-2a	Possible Check List.....	G-20
G-2b	Sample Transmission.....	G-20
G-3	Data Transmission Encoder Module - Manual.....	G-22
G-4	Data Transmission Encoder Module - Automatic.....	G-22
G-5	Vessel Passport System.....	G-24
G-6	Manual Monitoring System.....	G-30
G-7	Automatic Monitoring System.....	G-33
G-8	DF Surveillance System.....	G-36
G-9	Satellite Surveillance System (After Marisat).....	G-37

LIST OF TABLES
VOLUME III

<u>Table</u>		<u>Page</u>
D-1	EXISTING VESSEL TRAFFIC SYSTEMS IN U.S. PORTS AND WATERWAYS PRIOR TO 1972.....	D-2
D-2	ANNUAL CASUALTY TOTALS FOR COLLISIONS, RAMMINGS, AND GROUNDINGS (C/R/G), FY 1968-71	D-4
D-3	SERVICES PROVIDED BY A VTS.....	D-6
D-4	BASIC VTS FUNCTIONS AND AIDS.....	D-8
D-5	DIFFERENCES IN FUNCTION MODES AT FOUR VTSs.....	D-11
D-6	DUTY POSITIONS AT THREE VTSs.....	D-11
G-1	LORAN-A STATIONS.....	G-6
G-2	VHF AND 2182 kHz STATIONS.....	G-7
G-3	SUGGESTED RACON LOCATIONS.....	G-26
G-4	POSSIBLE VESSEL PASSPORT STATIONS.....	G-28
H-1	CURRENT SATELLITES APPLICABLE TO OVTM	H-3
H-2	PLANNED AND PROPOSED SATELLITES.....	H-5
I-1	OPERATIONAL FEATURE SCORES FOR EACH CASUALTY.....	I-4
I-2	NUMBER OF CASES WHERE SERVICES PROVIDED BY A MANUAL MONITORING STATION WOULD HAVE PROVED USEFUL.....	I-114
I-3	SYSTEMS SELECTED FOR DETAILED EVALUATION.....	I-124
I-4	SYSTEM SCORES.....	I-125
I-5	SUMMARY OF SYSTEM SCORES (BASELINE NOT INCLUDED).....	I-131
I-6	SYSTEM SCORES WITH BASELINE SYSTEM INCLUDED.....	I-135
I-7	SUMMARY OF SYSTEM SCORES INCLUDING BASELINE SYSTEM.....	I-141
I-8a	EQUIPMENT AVAILABILITY OF COLLISION AVOIDANCE AIDS.....	I-146

LIST OF TABLES (Continued)

<u>Table</u>		<u>Page</u>
I-8b	EQUIPMENT AVAILABILITY OF RADAR PERIMETER DETECTION DEVICES.....	I-146
I-8c	EQUIPMENT AVAILABILITY OF INTERROGATOR/ TRANSPONDER SYSTEMS.....	I-146
I-9	AN EXAMPLE OF SYSTEM SCORES.....	I-147

APPENDIX A

EXAMPLES OF MERCHANT VESSEL CASUALTY REPORTS

Two representative merchant vessel casualty reports, reproduced in toto, are included on the following pages.

The first report, case serial number 72865, contains (1) the endorsements of the Marine Inspection Officer In Charge and the Coast Guard District Commander, (2) a letter of transmittal from the Investigating Officer, and (3) U.S.C.G. form CG-2692 prepared by the vessel master. This report is most typical of the scope and depth of information available for each incident. If more than one vessel is involved in a casualty, each vessel master will prepare a form CG-2692.

The second report, case serial number 71355, contains the same enclosures. The significant difference is the extensive narrative contained in the Findings of Fact prepared by the investigating officer. This sort of detailed analysis is generally documented in cases where pollution resulted, deaths occurred, or a collision between vessels resulted in extensive damage.

72865 ✓

16732/MMIS 21879
18 October 1977

FIRST ENDORSEMENT on I. O., Philadelphia, PA report 16732/MMIS 21879 of
18 October 1977

From: Officer In Charge, Marine Inspection, Philadelphia, PA
To: Commandant (G-MMI-1/83)
Via: Commander, Third Coast Guard District (mvs)

Subj: M/V [REDACTED], (SG), O.N. [REDACTED]; Grounding, entrance to Delaware
Bay on 19 September 1977, with no personnel injuries and no pollution

1. Forwarded, approved.
2. A copy of this report has been forwarded to Commander, Third Coast Guard District (oan).
3. The original form CG-2692 for the [REDACTED] was forwarded with the year-end report.

D. W. SMITH

(mvs)
27 October 1977

SECOND ENDORSEMENT

From: Commander, Third Coast Guard District
To: Commandant (G-MMI-1/83)

1. Forwarded approved.

A. N. SCHROEDER
By direction

Copy to:
MIO Phila.



DEPARTMENT OF TRANSPORTATION
UNITED STATES COAST GUARD

RECEIVED

OCT 26 1977

MARINE SAFETY DIV.
WASHINGTON, D.C. 20540

MAILING ADDRESS:

Officer in Charge
Marine Inspection
801 Custom House
Philadelphia, PA 19106
(215) 597-4337

16732/MMIS 21879
18 October 1977

From: Investigating Officer, Philadelphia, PA
To: Commandant (G-MMI-1/83)
Via: (1) Officer In Charge, Marine Inspection, Philadelphia, PA
(2) Commander, Third Coast Guard District (mvs)
Subj: M/V [REDACTED], (SG), O.N. [REDACTED]; Grounding, entrance to Delaware Bay on 19 September 1977 with no personnel injuries and no pollution

1. The investigation of the casualty has been completed; a narrative report will not be submitted.
2. The proximate cause of the casualty was an error in judgement on the part of the Master, in that he underestimated the effect of current on his vessel. The vessel had slowed to 4 to 5 knots to pick up the pilot and was set to the right by the tidal current, grounding softly on the starboard bow, shortly before the pilot arrived on board.
3. The vessel was boarded by personnel of the Marine Inspection Office, Philadelphia, Captain of the Port, Philadelphia, and Atlantic Strike Team. There was no apparent damage and no loss of oil.
4. The vessel was refloated at 1200, 19 September 1977 and continued lightering to Interstate Oil Barge [REDACTED]. The vessel was unable to get underway because a mud-clogged strainer caused the loss of a generator. The vessel regrounded in the same position on the port quarter at 1630. The vessel continued lightering until high water at 0150, 20 September 1977 when the vessel was again afloat. The vessel was moved under its own power and without incident to Big Stone Anchorage in the Delaware Bay.
5. The aids to navigation in the area were checked on 19 September 1977 and were found to be watching properly.
6. The Master's comment in block 34 points to a need for action on the part of the Coast Guard for a change in aiding deep draft vessels entering Delaware Bay. The Master's recommendation would present one approach which might help to reduce the possibility of groundings. An alternative would be to move buoy R "2A", light list number 2095.10, approximately 1.2 miles to the west, which would prevent traffic from being led into the vicinity of the 37 foot shoal area, one mile west of the buoy's current position. This recommendation has the support of the Captain of the Port, and the Mariner's Advisory Committee.

16732/MIS 21879
18 October 1977

Subj: M/V [REDACTED], (SG), O.N. [REDACTED]; Grounding, entrance to Delaware Bay on 19 September 1977 with no personnel injuries and no pollution

The Master's comment that deep draft tankers should not enter the bay after dark is not concurred with. Pilots routinely bring vessels in without incident. The movement of vessels during periods of poor visibility is already adequately controlled by Navigation Rules.

7. It is recommended that a copy of this report be forwarded to Commander, Third Coast Guard District (oan).

8. There is no evidence of actionable misconduct, inattention to duty, negligence, or violation of law or regulation on the part of licensed or certificated persons, nor evidence that failure of inspected material or equipment, nor evidence that any personnel of the Coast Guard, or any other government agency or any other person contributed to the cause of this casualty. Therefore it is recommended that this casualty investigation be closed.

D. J. MARTYN

Encl: (1) COTP 221810 Z Sep 77

72865

DEPARTMENT OF TRANSPORTATION U. S. COAST GUARD CG-2692 (Rev. 12-70)	REPORT OF VESSEL CASUALTY OR ACCIDENT	Form Approved OMB No. 04-R3003 REPORTS CONTROL SYMBOL MV-4017
--	--	--

INSTRUCTIONS

1. An original and two copies of this form shall be submitted, without delay, to the Officer in Charge, Marine Inspection, in whose district the casualty occurred, or in whose district the vessel first arrived after such casualty.

2. If the person making the report is a licensed officer on a vessel required to be manned by such officer, he must make the report in writing and in person to the proper Marine Inspector. If because of distance it may be inconvenient for such an officer to submit the report in person, he may submit the required number of copies by mail. However, to avoid delay in investigations, it is desired that reports be submitted in person.

3. This form should be completed in full; blocks which do not apply to a particular case should be indicated as "NA". Where answers are unknown or none, they should be indicated as such. All copies should be signed.

NOTE: (1) Report all deaths and injuries, which incapacitate in excess of 72 hours, on CG-924E whether or not there was a vessel casualty.
 (2) Attach separate Form CG-924E to this report for each person killed or injured and incapacitated in excess of 72 hours as a result of the vessel casualty reported herein.

TO: Officer in Charge, Marine Inspection, Port of Philadelphia	DATE SUBMITTED 19 Sept 1977
---	---------------------------------------

I PARTICULARS OF VESSEL			
1. NAME OF VESSEL [REDACTED]	2. OFFICIAL NUMBER [REDACTED]	3. HOME PORT Singapore	4. NATIONALITY Singapore
5. TYPE OF VESSEL (Fr., pass., thr., etc.) tanker	6. PROPULSION (Steam, diesel, etc.) Diesel	7. GROSS TONNAGE 51,501	8. REGISTERED LENGTH OR L.O.A. 797.24' loa
9. HULL MATERIALS steel	10. YEAR BUILT 1974	11. RADIO EQUIPMENT <input checked="" type="checkbox"/> TRANSMIT <input checked="" type="checkbox"/> RECLIVE <input checked="" type="checkbox"/> VOICE <input checked="" type="checkbox"/> Cn (Key)	
12. (a) RADAR EQUIPPED <input checked="" type="checkbox"/> YES <input type="checkbox"/> NO		13. (b) RADAR OPERATING AT TIME OF CASUALTY <input checked="" type="checkbox"/> YES <input type="checkbox"/> NO	
13. (a) CERTIFICATE OF INSPECTION ISSUED AT PORT OF SOLAS Singapore		13. (b) DATE CERTIFICATE OF INSPECTION ISSUED 2/26/76	
14. (a) NAME OF MASTER OR PERSON IN CHARGE (Indicate which) [REDACTED]		14. (b) DATE OF BIRTH 9/4/30	14. (c) LICENSED BY COAST GUARD <input type="checkbox"/> YES <input checked="" type="checkbox"/> NO
15. (a) NAME OF PILOT (If on board at time of accident) none		15. (b) PILOT SERVING UNDER AUTHORITY OF LICENSE ISSUED BY <input type="checkbox"/> USCG N/A <input type="checkbox"/> STATE <input type="checkbox"/> FOREIGN	
16. (a) NAME OF OWNER(S), OPERATOR(S) OR AGENT (Indicate which) [REDACTED] owner [REDACTED] operator		16. (b) ADDRESS OF OWNER(S), OPERATOR(S), OR AGENT Singapore	

II PARTICULARS OF CASUALTY			
17. (a) DATE OF CASUALTY 9/19/77	17. (b) TIME OF CASUALTY (Local or zone) 0435 EDT	17. (c) ZONE DESCRIPTION	17. (d) TIME OF DAY <input type="checkbox"/> DAY <input checked="" type="checkbox"/> NIGHT <input type="checkbox"/> TWILIGHT
18. LOCATION OF CASUALTY (Latitude and longitude; distance and TRUE bearing from charted object; dock; anchorage; etc.) Latitude 38°47.9' Longitude 75° 00.8'			
19. BODY OF WATER (Geographical name) entrance to Delaware Bay	20. RULES OF THE ROAD APPLICABLE <input type="checkbox"/> INLAND <input type="checkbox"/> GREAT LAKES <input type="checkbox"/> WESTER. RIVERS <input checked="" type="checkbox"/> INTERNATIONAL <input type="checkbox"/> OTHER (Specify)		
21. (a) DID CASUALTY OCCUR WHILE UNDERWAY: <input checked="" type="checkbox"/> YES <input type="checkbox"/> NO			
21. (b) IF YES, LAST PORT OF DEPARTURE Ras Tanura, Saudi Arabia		21. (c) IF YES, WHERE BOUND WHEN CASUALTY OCCURRED Mobil Paulsboro (Philadelphia)	
22. (a) WEATHER CONDITIONS WHEN CASUALTY OCCURRED: <input type="checkbox"/> CLEAR <input type="checkbox"/> PARTLY CLOUDY <input checked="" type="checkbox"/> OVERCAST <input type="checkbox"/> FOG <input type="checkbox"/> RAIN <input type="checkbox"/> SNOW <input type="checkbox"/> OTHER (Specify)			
22. (b) VISIBILITY (Miles, yds., ft., etc.) 2-4 miles	22. (c) WIND DIRECTION west	22. (d) FORCE IN KNOTS 4 kts	22. (e) GUSTY <input type="checkbox"/> YES <input checked="" type="checkbox"/> NO
22. (f) AIR TEMPERATURE 22 C	22. (g) DIRECTION OF WIND west		
23. (a) SEA CONDITIONS WHEN CASUALTY OCCURRED light	23. (b) SEA WATER TEMP (if available) 21 C	23. (c) HEIGHT OF SEA 1 to 3 ft.	23. (d) DIRECTION OF SEA SW
23. (e) HEIGHT OF SWELL none		23. (f) DIRECTION OF SWELL none	
24. (a) NATURE OF CARGO (Specify) light Arabian Crude	24. (b) AMOUNT OF DRY CARGO (Long tons) NONE	24. (c) AMOUNT OF BULK LIQUID (Long tons) 678,513 bbls	24. (d) AMOUNT OF DECK LOAD (Long tons) none
25. (a) DRAFT FORWARD 47' 08"		25. (b) DRAFT AFT 48' 08"	
26. (a) TYPES OF LIFESAVING EQUIPMENT USED, IF ANY none		26. (b) NO. LIVES SAVED WITH LIFE-SAVING EQUIPMENT N/A	26. (c) LIFESAVING EQUIPMENT SATISFACTORY <input checked="" type="checkbox"/> YES <input type="checkbox"/> NO (If no, explain in Item 34)

PREVIOUS EDITION MAY BE USED

(Over)

27 CREW PASSENGERS OTHER (Specify)			28 ESTIMATED LOSS/DAMAGE TO YOUR VESSEL \$ <u>UNK</u>	
NUMBER ON BOARD <u>30</u> <u>0</u> <u>0</u>			ESTIMATED LOSS/DAMAGE TO YOUR CARGO \$ <u>UNK</u>	
DEAD/MISSING <u>0</u>			ESTIMATED LOSS/DAMAGE TO OTHER PROPERTY \$ <u>none</u>	
INCAPACITATED (over 3 days)			(Specify whether vessel, dock, bridge, etc.)	
29. NATURE OF THE CASUALTY (Check one or more of the following. Give pertinent details in item 30.)				
COLLISION WITH OTHER VESSEL(S) (Specify)		EXPLOSION/FIRE (Other)		
		<input checked="" type="checkbox"/> GROUNDING		
		FOUNDER (Sinking)		
COLLISION WITH FLOATING OR SUBMERGED OBJECTS		CAPSIZING WITHOUT SINKING		
COLLISION WITH FIXED OBJECTS (Piers, bridges, etc.)		FLOODING, SWAMPING, ETC. WITHOUT SINKING		
COLLISION WITH ICE		HEAVY WEATHER DAMAGE		
COLLISION WITH AIDS TO NAVIGATION		CARGO DAMAGE (No vessel damage)		
COLLISION (Other)		MATERIAL FAILURE (Vessel structure)		
EXPLOSION/FIRE (Involving cargo)		MATERIAL FAILURE (Engineering machinery, including main propulsion, auxiliaries, boilers, evaporators, deck machinery, electrical, etc.)		
EXPLOSION/FIRE (Involving vessel's fuel)				
FIRE (Vessel's structure or equipment)		EQUIPMENT FAILURE		
EXPLOSION (Boiler and associated parts)		CASUALTY NOT NAMED ABOVE		
EXPLOSION (Pressure vessels and compressed gas cylinders)				
30. DESCRIPTION OF CASUALTY (Events and circumstances leading to casualty and present when it occurred. Attach diagram and additional sheets, if necessary)				
<p>Vessel was approaching Delaware Bay through Delaware to Cape Henlopen traffic Lane. The engine was put slow ahead waiting for the pilot at 0425 due south 180° .9 mile from buoy R2A (radar fix), and course was changed to 292°. Speed at slow ahead is 4 to 5 kts. The strong tidal current set the ship to the right grounding softly at 0435 due west of buoy R 2 A (270°) .85 miles. Vessel grounded on Stbd bow. Vessel floated free at 1200. Regrounded at 1600 as tide went out. Vessel at anchor. Generator undergoing repair not related to grounding.</p>				
31. DAMAGE (Give brief general description and state if vessel is a total loss.)				
<p>No apparent damage, pending bottom survey. Sounded forepeak, cofferdams, ballast tanks, took ullage in cargo tanks. No leakage found.</p>				
III ASSISTANCE AND RECOMMENDATIONS				
32. AUTO ALARMS TRANSMITTED BY YOUR VESSEL: <input type="checkbox"/> YES <input checked="" type="checkbox"/> NO				
33(a) ASSISTANCE RENDERED BY STATIONS AND VESSELS (Include Coast Guard and other stations and vessels)		(b) OTHER ASSISTANCE RENDERED		
<p>Lightering by Interstate Oil barge 140 and tug Ranger</p>		<p>none</p>		
34. RECOMMENDATIONS FOR CORRECTIVE SAFETY MEASURES PERTINENT TO THIS CASUALTY (Include explanation of unsatisfactory lifesaving equipment)				
<p>Recommend that pilots board ship at the end of the traffic lane "DC" buoy. Deep draft vessel with cargo oil should not enter channel to Bay after dark or in poor visibility.</p>				
TITLE Master		SIGNATURE 		

71355 ✓

16732/C-47-77
9 August 1977

FIRST ENDORSEMENT on Investigating Officer CG MSO Juneau ltr 16732 of 22 March 1977

From: Commanding Officer, CG Marine Safety Office, Anchorage, AK
To: Commandant (G-MMI-1)
Via: Commander, Seventeenth Coast Guard District (m)

Subj: MV [REDACTED], O.N. [REDACTED]; grounding off East Forelands, Cook Inlet, AK., on 5 October 1976, without loss of life.

1. Forwarded approved.
2. MSO Anchorage Case Number C-47-77 has been assigned.
3. A report of violation has been submitted concerning Capt. [REDACTED] action in this incident.
4. A Water Pollution Violation Report has been submitted for the spill resulting from this casualty.
5. A source-fact letter will be forwarded to OCMI Houston, TX., the port of Captain [REDACTED] last known permanent home address, for such action as that office may deem appropriate.

K. Nichols
K. Nichols

Copy to:
MSO Juneau

16732
12 August 1977

SECOND ENDORSEMENT

From: Commander, Seventeenth Coast Guard District
To: Commandant (G-MMI-1)

1. Forwarded approved.
2. Alleged violation is under review.

V. E. Cox
V. E. COX
By direction



DEPARTMENT OF TRANSPORTATION
UNITED STATES COAST GUARD

MAILING ADDRESS:
Commanding Officer
Marine Safety Office
612 Willoughby Ave
Juneau, Alaska 99801
•TELE: (907)586-7288

16732
22 March 1977

From: Investigating Officer, MSO Juneau
To: Commandant (G-MMI)
Via: (1) Officer-in-Charge, Marine Inspection, Anchorage, AK
(2) Commander, Seventeenth Coast Guard District(m)
Subj: M/V [REDACTED], O.N. [REDACTED]; grounding off East Forelands, Cook Inlet, Alaska on 5 October 1976, without loss of life

FINDINGS OF FACT

1. The M/V [REDACTED] grounded off East Forelands on 5 October 1976 in the approximate position of 60-48.9N, 151-29W. As a result of this casualty extensive bottom damage was incurred and approximately 9421 bbls of JP-4 cargo was lost or not accounted for.

2. Vessel data:

NAME	:	[REDACTED]
OFFICIAL NUMBER	:	[REDACTED]
SERVICE	:	TANKER
GROSS TONS	:	17,134.15
NET TONS:	:	11,886
HULL MATERIAL	:	STEEL/WELDED
LENGTH:	:	563.8'
BREADTH	:	84.1'
DEPTH	:	45.7'
PROPULSION	:	OIL SCREW
HORSEPOWER	:	14,000
HOMEPORT:	:	WILMINGTON, DELAWARE
OWNERS	:	[REDACTED] TRUSTEE
MASTER	:	[REDACTED]
LICENSE	:	LICENSE NUMBER [REDACTED], MASTER OF OCEAN STEAM OR MOTOR VESSELS ANY GROSS TONS, RADAR OBSERVER, FIRST CLASS PILOT OF TAMPA AND

16732
22 March 1977

Subj: M/V [REDACTED], O.N. [REDACTED]; grounding off
East Forelands, Cook Inlet, Alaska on 5 October 1976,
without loss of life.

LICENSE(CONT.) : HILLSBOROUGH BAYS AT
TAMPA FLORIDA, AND FROM
JUNCTION OF "K" CUT
CHANNEL, FLORIDA POWER
CORPORATION PLANT, WEEDEN
ISLAND, FLORIDA, AND
DELAWARE BAY FROM LEWFS,
DELAWARE TO CAPE MAY, NEW
JERSEY.
USMMD : Z-245 539-D2
CERTIFICATE OF INSPECTION : ISSUED 18 AUGUST 1976 AT
LOS ANGELES, CALIFORNIA

As a result of this casualty the vessel received extensive bottom damage and all cargo tanks were holed with the exception of 3C, 4P, 5P, 6P, 7P, 7C, and 7S. The field survey, conducted in Seattle, Washington by U. S. Salvage, dated October 29, 1976 lists the extent of damages found when the vessel was drydocked (EXHIBIT Z). All repairs were completed to the satisfaction of the Officer-in-Charge, Marine Inspection, Seattle, Washington.

3. The weather at the time of the casualty was as follows: wind northerly force 3 (Beaufort Scale), temperature 50 degrees Fahrenheit, Barometer 29.76, seas slight with a light chop, sky overcast with a light drizzle and visibility 8-10 miles. The tide predictions at 0912 for 5 OCT 76 were taken on Seldovia for East Foreland and was a plus 1.7 feet. The current was taken off Wrangell Narrows for Nikiski and the predicted velocity at 0912 for 5 OCT 76 was 3.344 knots. One radar (3 Centimeter) was operating normally and was in use at the time of the casualty. The other surface radar (10 centimeter) was inoperable. The mate on watch used the radar to obtain ranges and bearings from fixed objects and relied solely on this method to fix the vessels position. All other navigating equipment on the bridge was operating normally. All times used in this report are Alaska Daylight Saving Time (ADST)(+9), unless otherwise indicated. Navigational equipment particulars aboard the vessel are as follows:

RADAR(3cm)
RAYTHEON SELENIA
Model 1645/6XB
16 inch cathode-ray tube
Built 1972
True and Relative bearing capability
Bearing resolution--1% or better
Range resolution---better than 75 yards

16732
22 March 1977

Subj: M/V [REDACTED], O.N. [REDACTED]; foundering off
East Forelands, Cook Inlet, Alaska on 5 October 1976,
without loss of life

RADAR(3cm)(CONT.)
Range Scales-- $\frac{1}{2}$ -1 $\frac{1}{2}$ -3-6-12-24-48 miles

RADAR(10cm)
RAYTHEON SELENIA
Model 1660/12SB
16 inch cathode-ray tube
Built 1972
True and Relative bearing capability
Bearing resolution--1% or better
Range resolution--better than 75 yards
Range Scales-- $\frac{1}{2}$ -1 $\frac{1}{2}$ -3-6-12-24-48 miles

LORAN--ITT MACKAY Model 4207 with "A" and "C" capability

Radio Direction Finder--ITT MACKAY Model 4004

OMEGA--SPERRY Model SR-500

4. The M/V [REDACTED] commenced the voyage at San Pedro, California on 26 SEP 76. As was the usual practice, the vessel engaged and embarked a pilot for the waters expected to be traversed prior to departure. For this specific trip the vessel engaged Captain [REDACTED]. Captain [REDACTED] holds U. S. Coast Guard license number [REDACTED] endorsed as Master, Ocean Steam or Motor vessels of any gross tons: Radar Observer; Also First Class Pilot of the waters of Southeastern and Southwestern Alaska. This license was issued to Captain [REDACTED] on 19 OCT 73 in Seattle, Washington and is valid for a period of five years. Captain [REDACTED] also holds a State of Alaska, Department of Commerce, license which states on the face:
"This certifies that [REDACTED] has fulfilled all the requirements of the laws of Alaska, and possessing the prescribed qualifications, is hereby authorized to practice as a marine pilot of the Southeastern and Southwestern Inland Waters in the State of Alaska, any gross ton." This license expired on December 31, 1976.

5. The first port of call was Kodiak, Alaska where the vessel discharged a partial load of JP-5 jet fuel cargo. The vessel, having completed discharging cargo at Kodiak, had 18 of the 21 cargo tanks filled. The three empty tanks were number fours across. The M/V [REDACTED] departed Kodiak at about 0930 on 4 OCT 76 and was bound for the Tessoro Pet Company Terminal at Nikiski, Alaska and had approximately 175,000 bbls of cargo remaining on board. The vessel's draft reading just prior to departure was 27 feet 2 inches forward, 32 feet 9 inches aft. The master estimated burnoff and water

16732

22 March 1977

Subj: M/V [REDACTED], O.N. [REDACTED]; foundering off
East Forelands, Cood Inlet, Alaska on 5 October 1976,
without loss of life

usage in any 24 hour period would not exceed one (1) inch per day. The purpose of the call at Nikiski was to load 25,000 bbls of diesel. After the vessel had taken departure at Kodiak and was outside pilot waters, Captain [REDACTED], the pilot, was relieved of all navigating responsibilities by other ship's officers. As was discussed between the master, Captain [REDACTED], and the pilot, Captain [REDACTED], it was determined the vessel was to proceed at slow speed with one engine (Starboard) in order to arrive alongside the pier at Nikiski at about 1000. This would be approximately low slack water on the morning of the 5th of October 1976. During the course of this conversation the pilot requested that he be permitted to anchor the vessel before going into Nikiski because of the long period of time his services would be required. The Master, Captain [REDACTED], told Captain [REDACTED] this would not be possible. The master advised that union regulations required the vessel to provide a liberty launch if they anchored. Condescending to the Masters wishes, Captain [REDACTED] agreed to remain on watch and take the vessel into Nikiski even though the watch would be more than 8 consecutive hours.

6. The vessel proceeded without incident and at 0110 on the 5th of October 1976 Captain [REDACTED] again assumed the con of the vessel upon entering pilot waters. The vessel progressed into Cook Inlet and at about 0800 the third mate, Mr. [REDACTED], relieved the mate on watch and noted that Captain [REDACTED] was conning the vessel. Mr. [REDACTED] fixed the vessel's position at 0806 by using a radar range and bearing. At 0825 another engine was placed on the line to speed up the vessel and provide sufficient power for maneuvering the vessel when coming alongside the berth at Nikiski. With both engines on the line the vessel was placed in the cruise mode which gave the vessel full speed of 16 knots.

7. Captain [REDACTED] came on the bridge at about 0845 and looked at the position that had just been plotted by Mr. [REDACTED]. The master conversed with the pilot concerning the arrival time and directed the Chief Engineer to provide the water and fuel report so that it could be included in the arrival message. It was the master's intention to take arrival at 0930. The master drafted a message after obtaining the essential information and decided he would personally take the message to the radio-room in view of the time remaining before he would be needed on the bridge. The master in Kodiak, and again on the morning of 5 October directed Mr. [REDACTED] to pay specific and particular attention to the pitch control when the vessel began to maneuver. The purpose of this was to observe any malfunction in the pitch control immediately in order that

16732
22 March 1977

Subj: M/V [REDACTED], O.N. [REDACTED]; grounding off East Forelands, Cook Inlet, Alaska on 5 October 1976 without loss of life

corrective action could be taken in time to avoid any casualties. The pitch control had previously malfunctioned during the approach to Kodiak and the master wanted to avoid a repeat of this incident. The Chief Engineer repaired the previous minor malfunction in the system and there had not been a recurrence since the Kodiak incident. Captain [REDACTED] order to pay particular attention to the pitch controls required the mate on watch to be in almost constant attendance at the pitch control panel. As a consequence, the mate had little time available for other required navigational duties. Having given specific instruction, and drafting the message, the Master proceeded below to the radio-room at about 0900 to deliver the arrival report.

8. At about 0906, when buoy 2 was just abaft the beam, the pilot, Captain [REDACTED], ordered the helm to be put right 15 degrees. When the vessel had changed course from about 010 degrees (GYRO) to about 060 degrees (GYRO) the pilot ordered the helmsman to steady-up. When the helmsman called out 064 degrees the pilot ordered the helmsman to hold course. This course was maintained for approximately 6 minutes when the pilot gave the order to come right with 15 degrees rudder and to come to a heading of 090 degrees (GYRO). When the vessel was passing about 080 degrees the vessel began to vibrate. The helmsman described the vibration as feeling the engines or the pitch control had reversed. The helmsman visually observed the pitch control and revolution gages and both appeared to be normal. Having observed this, his first impression was that the vessel had run aground. Approximately 30 seconds or less after the first vibrations, the vessel again started to shudder and at this time the helmsman was positive the vessel had grounded. The vessel came to a stop a short time later and the Mate on watch Mr. [REDACTED], directed the helmsman to put the rudder amidships. The helmsman noted the vessel had reached approximately 085 degrees (GYRO) and more or less steadied up on this heading after the vessel had come to a complete stop. The mate, Mr. [REDACTED], noted a strong smell of cargo (JP-4) and observed a black streak in the water up forward on the port side and also noted the surrounding water was somewhat discolored which he assumed to be the vessels cargo (JP-4). Having observed the water and smelled the strong odor of the vessel's cargo, the mate directed the helmsman to leave his post and proceed below to tell the cook and other crewmembers to put out any cigarettes or open fires and to secure the galley. He was also to advise other crewmembers that cargo had spilled and to exercise all necessary precautions to prevent a fire or explosion.

16732
22 March 1977

Subj: M/V [REDACTED], O.N. [REDACTED]; grounding off East Forelands, Cook Inlet, Alaska on 5 October 1976, without loss of life

9. Captain [REDACTED], who was at the radio-room with the Chief Engineer, felt the vibrations and proceeded immediately to the wheelhouse. The Chief Engineer noting the same vibration departed immediately to the engineroom. Upon arrival in the wheelhouse, the master inquired as to what had happened and assumed control of the vessel's operations. Captain [REDACTED] noticed the engines were stopped but were still engaged and that the vessel had taken a pronounced starboard list and had reached an attitude of almost 12 degrees. Captain [REDACTED] simultaneously pushed the appropriate buttons to disengage the engines and called the engineroom to confirm the engines were not engaged. Having spent a few moments assessing the situation, the master went to the port wing of the bridge and noticed a black streak in the water up forward and also noted the strong, pungent odor of the vessel's cargo. Having briefly assessed the situation, Captain [REDACTED] directed the Chief Mate and the pumpman to commence gravitating cargo into number four port tank. The purpose of this was to ascertain if the cargo lines were still intact and to take the list off the vessel. A short time after gravitation began and the lines were found intact, the master ordered the cargo pump started to transfer oil to number four port tank. After about 20 minutes enough cargo had been transferred to bring the vessel back to an approximate even keel. The master then directed the third mate, Mr. [REDACTED], to obtain a bearing and distance from East Forelands Light and directed the radio operator to notify the U. S. Coast Guard in Anchorage, Alaska of the casualty and of the pollution. At about this same time, the master noted the vessel was going down by the head as he was attempting to level the vessel. He then ordered that soundings be taken of all tanks and spaces to better assess the damages. It was reported that NO4C and NO4S were holed and taking on water. The master calculated this flooding of empty tanks is what caused the vessel to be down by the head. At about this same time, 0930, Mr. [REDACTED] advised the master the vessel was drifting and had way on. Captain [REDACTED] continued with his damage control efforts for a short time and at 0957 ordered the port anchor let go. A fix of the vessel's position at the time of anchoring was 60-51.5N, 151-27.8W.

10. The pilot, Captain [REDACTED], had been on watch continuously since 0110 in the morning without any relief whatsoever. Captain [REDACTED] testified that he had had much previous experience in the area and was very familiar with all of the surroundings and waters. While Captain [REDACTED] was piloting he last noted the radar at about 0705 in the morning and more or less took a range off Kalgin Island and noted the vessel was about 4.8 miles distant. Based on his experience in the area and his

16732
22 March 1977

Subj: M/V [REDACTED], O.N. [REDACTED]; grounding off East Forelands, Cook Inlet, Alaska on 5 October 1976, without loss of life

local knowledge, the pilot also testified that he had not used the chart and was relying solely on seaman's eye as his means of fixing the vessels position. Captain [REDACTED] stated the position placed on the chart by the third mate Mr. [REDACTED], at 0906 was in error. Captain [REDACTED] did not question any other position placed on the chart by Mr. [REDACTED] and assumed they were all correct. Captain [REDACTED] offered into testimony exhibit AA which was chart 16660. On this exhibit Captain [REDACTED] had drawn a reconstructed course line from the 0845 position to a 0901 position. In his reconstruction, it brought the vessel's position, with a course of 010 degrees True, to the point where the vessel made its turn at time 0901. Captain [REDACTED] reconstruction of the trackline placed the vessel in good water and clear of the known charted shoal area. However, upon further inquiry and reconstructing the vessel's position and a trackline a second time and using the vessel's speed of 16 knots, which previous testimony stated the maximum speed of the vessel to be, and using a current of 2 knots, which the vessel would have to stem and which approximated the actual conditions encountered, this second reconstruction of the vessel's trackline by Captain [REDACTED] caused the trackline to traverse over the known and charted shoal area. The depths of water in this known shoal area range from 24 feet to 30 feet at Mean Lower Low Water (MLLW).

11. The vessel having anchored, commenced pollution and damage control efforts. A lightering operation was set up to discharge the remaining cargo aboard the vessel. After a concerted effort on the part of ship's personnel, assisting agencies, owners and other persons, it was ascertained that all cargo had been recovered with the exception of about 9421 bbls which either spilled into Cook Inlet or was otherwise not accounted for. There was no apparent visible damage to the environment as a result of this spill. However, efforts are still ongoing by appropriate agencies to evaluate the affects this spill may have caused.

12. Having completed all lightering operations satisfactorily, the vessel, using the ship's own propulsion and in escort of tugs, departed Nikiski at about 1042 GMT on the 18th of October 1976 bound for Resurrection Bay off Seward, Alaska. The purpose of proceeding to this area was to get into clear water, since Cook Inlet is heavily silted. This would then enable divers to obtain a more unobstructed view of damages and permit responsible persons to evaluate the hull girder for seaworthiness.

16732
22 March 1977

Subj: M/V [REDACTED], O.N. [REDACTED]; grounding off East Forelands, Cook Inlet, Alaska on 5 October 1976, without loss of life

CONCLUSIONS

1. It is concluded the M/V [REDACTED] grounded in the approximate position of 60-42.9N, 151-29W.
2. It is concluded the cause of this casualty was the pilot's failure to correctly and accurately ascertain in the vessel's position as well as take into consideration the effects of the current, while making an approach to Nikiski. By such failure, a course change was initiated which took the vessel over a known and charted shoal area.
3. Contributory to this casualty was the fatigue of the pilot from having stood watch for over 8 continuous hours without relief.
4. Contributory to this casualty was the mate's compliance with the Master's order to pay particular attention to the pitch controls and to the extent that almost all other navigating duties were excluded.
5. It is concluded the vessel grounded twice and came to a complete stop and was hard aground after the second grounding.
6. It is concluded that Captain [REDACTED] did not take into consideration the affects the current had on the vessel and therefore anticipated the vessel was north of the actual position at the time the turn toward Nikiski was made.
7. It is further concluded that the position at 0901, as reconstructed by Captain [REDACTED], was in error because Captain [REDACTED] allowed a speed of 18 knots through the water when the approximate actual conditions encountered was 14 knots or less.
8. It is concluded that the ballasting of the vessel by the master in order to place the vessel on an even keel, combined with the effects of the wind and current, caused the vessel to become adrift.
9. The master used poor judgment when he ordered ballasting the vessel without first having completed a full damage survey. Had there been additional damage to the vessels stability the

16732

22 March 1977

Subj: M/V [REDACTED] O.N. [REDACTED]; grounding off East Forelands, Cook Inlet, Alaska on 5 October 1976, without loss of life

vessel would in all probability have come adrift and sunk.

10. The pilot, Captain [REDACTED], was operating under the authority of his Alaska State Pilots License in that the vessel was sailing under register.

11. There is evidence of negligence on the part of the master in that he failed to provide sufficient personnel on the bridge to safely navigate the vessel in that he ordered the mate to watch the pitch control to the almost absolute exclusion of other navigating duties.

12. There is evidence of negligence on the part of the master in that he failed to provide sufficient relief for the pilot or otherwise stop the vessel to provide relief and rest.

13. There is evidence of negligence on the part of the pilot in that he failed to correctly and accurately ascertain the vessel's position prior to commencing the approach to Nikiski thereby taking the vessel over a known charted shoal area.

14. There is evidence of violation of 33 USC 1321 in that about 9421 bbls of petroleum was spilled into Cook Inlet as a result of this casualty.

15. There is no evidence that any person of the Coast Guard, or any other government agency or any other persons contributed to the casualty.

16732
22 March 1977

Subj: M/V [REDACTED] O.N. [REDACTED]; grounding off East Forelands, Cook Inlet, Alaska on 5 October 1976 without loss of life.

RECOMMENDATIONS

1. It is recommended that further investigation under the Suspension and Revocation Proceedings be initiated in the case of Captain [REDACTED] concerning his part in the casualty.
2. Recommend that evidence of negligence on the part of the Pilot Captain [REDACTED] be processed under the Administrative Penalty Procedures.
3. Recommend the casualty aspect of this case be closed with the submission of this report.

R. H. SPOLTMAN

LIST OF ENCLOSURES AND DISTRIBUTION FOR IO, MSO JUNEAU LTR
16732 DTD 22 MAR 77

- Encl: (1) CG-2692
(2) Convening Order
(3) Verbatim testimony of witnesses (except Captain
[REDACTED])
(4) Verbatim testimony of Captain [REDACTED]
(5) Exhibits (A through AA--xerox copy)
(6) Vessel Certificate of Inspection (xerox copy)
(7) Vessel Document (xerox copy)
(8) Copy of order to Testify and Grant of Immunity

Distribution:

MSO Anchorage w/encl (1)
CCGD17(m) w/o encl (1)
COMDT (G-MMI) w/encl (4)

DEPARTMENT OF
TRANSPORTATION
U. S. COAST GUARD
CG-2692 (Rev. 12-70)

REPORT OF VESSEL CASUALTY OR ACCIDENT

Form Approved
OMB No. 04-R3003
REPORTS CONTROL SYMBOL
MVI-4017

INSTRUCTIONS

1. An original and two copies of this form shall be submitted, without delay, to the Officer in Charge, Marine Inspection, in whose district the casualty occurred, or in whose district the vessel first arrived after such casualty.
2. If the person making the report is a licensed officer on a vessel required to be manned by such officer, he must make the report in writing and in person to the proper Marine Inspector. If because of distance it may be inconvenient for such an officer to submit the report in person, he may submit the required number of copies by mail. However, to avoid delay in investigations, it is desired that reports be submitted in person.

3. This form should be completed in full; blocks which do not apply to a particular case should be indicated as "NA". Where answers are unknown or none, they should be indicated as such. All copies should be signed.
- NOTE: (1) Report all deaths and injuries, which incapacitate in excess of 72 hours, on CG-924E whether or not there was a vessel casualty.
- (2) Attach separate Form CG-924E to this report for each person killed or injured and incapacitated in excess of 72 hours as a result of the vessel casualty reported herein.

TO: Officer in Charge, Marine Inspection, Port of <u>ANCHORAGE, ALASKA</u>		DATE SUBMITTED <u>OCTOBER 18, 1976</u>	
I PARTICULARS OF VESSEL			
1. NAME OF VESSEL [REDACTED]	2. OFFICIAL NUMBER [REDACTED]	3. HOME PORT <u>WILMINGTON, DEL.</u>	4. NATIONALITY <u>USA</u>
5. TYPE OF VESSEL (Pri., pass., tkr., etc.) <u>MOTOR TANKER</u>	6. PROPULSION (Steam, diesel, etc.) <u>DIESEL</u>	7. GROSS TONNAGE <u>17134.15</u>	8. REGISTERED LENGTH OR L.O.A. <u>587 Ft.</u>
9. HULL MATERIALS <u>STEEL</u>	10. YEAR BUILT <u>KEEL 1972</u>	11. RADIO EQUIPMENT <input checked="" type="checkbox"/> TRANSMIT <input checked="" type="checkbox"/> RECEIVE <input checked="" type="checkbox"/> VOICE <input checked="" type="checkbox"/> CB (Key)	
12. (a) RADAR EQUIPPED <input checked="" type="checkbox"/> YES <input type="checkbox"/> NO	(b) IF YES, RADAR OPERATING AT TIME OF CASUALTY <input checked="" type="checkbox"/> YES <input type="checkbox"/> NO		
13. (a) CERTIFICATE OF INSPECTION ISSUED AT PORT OF <u>LONG BEACH, CA.</u>	(b) DATE CERTIFICATE OF INSPECTION ISSUED <u>9/24/76</u>		
14. (a) NAME OF MASTER OR PERSON IN CHARGE (Indicate which) [REDACTED]	(b) DATE OF BIRTH <u>AUGUST 31, 1923</u>	(c) LICENSED BY COAST GUARD <input checked="" type="checkbox"/> YES <input type="checkbox"/> NO	
15. (a) NAME OF PILOT (If on board at time of accident) <u>CAPT. [REDACTED]</u>	(b) PILOT SERVING UNDER AUTHORITY OF LICENSE ISSUED BY <input checked="" type="checkbox"/> USCG <input checked="" type="checkbox"/> STATE <input type="checkbox"/> FOREIGN		
16. (a) NAME OF OWNER(S), OPERATOR(S) OR AGENT (Indicate which)	(b) ADDRESS OF OWNER(S), OPERATOR(S), OR AGENT		
II PARTICULARS OF CASUALTY			
17. (a) DATE OF CASUALTY <u>05 OCT. 1976</u>	(b) TIME OF CASUALTY (Local or zone) <u>APPROXIMATELY 0913/18</u>	(c) ZONE DESCRIPTION <u>Z.D. = 9</u>	(d) TIME OF DAY <input checked="" type="checkbox"/> DAY <input type="checkbox"/> NIGHT <input type="checkbox"/> TWILIGHT
18. LOCATION OF CASUALTY (Latitude and longitude; distance and TRUE bearing from charted object; dock; anchorage; etc.) <u>EAST OF EAST FORELAND, NIKISKI, ALASKA ONE TO TWO MILES</u>			
19. BODY OF WATER (Geographical name) <u>COOK INLET, AK.</u>	20. RULES OF THE ROAD APPLICABLE <input checked="" type="checkbox"/> INLAND <input type="checkbox"/> GREAT LAKES <input type="checkbox"/> WESTERN RIVERS <input type="checkbox"/> INTERNATIONAL <input type="checkbox"/> OTHER (Specify)		
21. (a) DID CASUALTY OCCUR WHILE UNDERWAY: <input checked="" type="checkbox"/> YES <input type="checkbox"/> NO			
(b) IF YES, LAST PORT OF DEPARTURE <u>KODIAK, ALASKA</u>		(c) IF YES, WHERE BOUND WHEN CASUALTY OCCURRED <u>PHILLIPS DOCK, NIKISKI, AK.</u>	
22. (a) WEATHER CONDITIONS WHEN CASUALTY OCCURRED: <input checked="" type="checkbox"/> CLEAR <input type="checkbox"/> PARTLY CLOUDY <input checked="" type="checkbox"/> OVERCAST <input type="checkbox"/> FOG <input type="checkbox"/> RAIN <input type="checkbox"/> SNOW <input type="checkbox"/> OTHER (Specify)			
(b) VISIBILITY (Miles, yds., ft., etc.) <u>APPROXIMATELY 8 MILES</u>	(c) WIND DIRECTION <u>N'LY</u>	(d) FORCE IN KNOTS <u>11</u>	(e) GUSTY <input type="checkbox"/> YES <input checked="" type="checkbox"/> NO
(f) AIR TEMPERATURE <u>48</u>			
23. (a) SEA CONDITIONS WHEN CASUALTY OCCURRED <u>small N'LY</u>	(b) SEA WATER TEMP (If available) <u>47</u>	(c) HEIGHT OF SEA <u>ONE FOOT</u>	(d) DIRECTION OF SWELL <u>N'LY</u>
(e) HEIGHT OF SWELL <u>ONE FOOT</u>	(f) DIRECTION OF SWELL <u>N'LY</u>		
24. (a) NATURE OF CARGO (Specify) <u>JP-4 JET FUEL</u>	(b) AMOUNT OF DRY CARGO (Long tons) <u>NA</u>	(c) AMOUNT OF BULK LIQUID (Long tons) <u>APPROXIMATELY 22,400</u>	(d) AMOUNT OF DECK LOAD (Long tons) <u>NA</u>
25. (a) DRAFT FORWARD <u>27 FT 02 INCHES</u>		(b) DRAFT AFT <u>32 FT 07 INCHES</u>	
26. (a) TYPES OF LIFESAVING EQUIPMENT USED, IF ANY <u>NA</u>		(b) NO. LIVES SAVED WITH LIFE-SAVING EQUIPMENT <u>NA</u>	(c) LIFESAVING EQUIPMENT DATED-FACTORY <input checked="" type="checkbox"/> YES <input type="checkbox"/> NO (If no, explain in item 34)

27	27	CREW 0 PASSENGERS OTHER(Specify)	28	ESTIMATED LOSS/DAMAGE TO YOUR VESSEL	\$ 3,000,000	
NUMBER ON BOARD 27			ESTIMATED LOSS/DAMAGE TO YOUR CARGO			\$ 100,000
DEAD/MISSING			ESTIMATED LOSS/DAMAGE TO OTHER PROPERTY			\$
INCAPACITATED (over 3 days) 0			(Specify whether vessel, dock, bridge, etc.)			

29 NATURE OF THE CASUALTY (Check one or more of the following. Give pertinent details in item 30.)

<input type="checkbox"/>	COLLISION WITH OTHER VESSEL(S) (Specify)	<input type="checkbox"/>	EXPLOSION/FIRE (Other)
<input type="checkbox"/>		<input type="checkbox"/>	GROUNDING
<input type="checkbox"/>		<input type="checkbox"/>	FOUNDER (Sinking)
<input checked="" type="checkbox"/>	COLLISION WITH FLOATING OR SUBMERGED OBJECTS	<input type="checkbox"/>	CAPSIZING WITHOUT SINKING
<input type="checkbox"/>	COLLISION WITH FIXED OBJECTS (Piers, bridges, etc.)	<input checked="" type="checkbox"/>	FLOODING, SWAMPING, ETC. WITHOUT SINKING
<input type="checkbox"/>	COLLISION WITH ICE	<input type="checkbox"/>	HEAVY WEATHER DAMAGE
<input type="checkbox"/>	COLLISION WITH AIDS TO NAVIGATION	<input type="checkbox"/>	CARGO DAMAGE (No vessel damage)
<input type="checkbox"/>	COLLISION (Other)	<input type="checkbox"/>	MATERIAL FAILURE (Vessel structure)
<input type="checkbox"/>	EXPLOSION/FIRE (Involving cargo)	<input type="checkbox"/>	MATERIAL FAILURE (Engineering machinery, including main propulsion, auxiliaries, boilers, evaporators, deck machinery, electrical, etc.)
<input type="checkbox"/>	EXPLOSION/FIRE (Involving vessel's fuel)	<input type="checkbox"/>	EQUIPMENT FAILURE
<input type="checkbox"/>	FIRE (Vessel's structure or equipment)	<input type="checkbox"/>	CASUALTY NOT NAMED ABOVE
<input type="checkbox"/>	EXPLOSION (Boiler and associated parts)		
<input type="checkbox"/>	EXPLOSION (Pressure vessels and compressed gas cylinders)		

30. DESCRIPTION OF CASUALTY (Events and circumstances leading to casualty and present when it occurred. Attach diagram and additional sheets, if necessary)

WHILE HEADING FOR EAST FORELAND POINT LIGHT VESSEL STRUCK SUBMERGED OBJECT.

31. DAMAGE (Give brief general description and state if vessel is a total loss.)

VESSEL SUFFERED BOTTOM DAMAGE AS PER DIVERS REPORT

III ASSISTANCE AND RECOMMENDATIONS

32. AUTO ALARM TRANSMITTED BY YOUR VESSEL: YES NO

33(a) ASSISTANCE RENDERED BY STATIONS AND VESSELS (Include Coast Guard and other stations and vessels)	33(b) OTHER ASSISTANCE RENDERED
USCG PACIFIC STRIKE TEAM, SAN FRANCISCO, CA	THE SEA LION THE LINE FISS THESE TOWERS STOOD BY IN CASE ASSISTANCE WAS REQUIRED

34. RECOMMENDATIONS FOR CORRECTIVE SAFETY MEASURES PERTINENT TO THIS CASUALTY (Include explanation of unsatisfactory lifesaving equipment)

TITLE: MASTER

SIGNATURE: [Redacted]

APPENDIX B
MERCHANT VESSEL CASUALTY COMPUTERIZED DATA BASE

The following data parameters are coded for entry into the computerized data base:

GROUP I - VESSEL CHARACTERISTICS

Vessel Identification - Official U.S. or State number, name if unnumbered, country of registry, if foreign.

Type of Vessel - Tankship, tank barge, freighter, passenger, foreign flag tanker, etc.

Specific Type Vessel - Construction, usage, type of cargo.

Gross Tonnage - Not over 15, 15-100, 100-300, 300-500, 500-1000, 1000-5000, 5000-10,000, 10,000-15,000, over 15,000.

Length in Feet - Not over 65, 65-100, 100-200, etc.

Propulsion - Steam, diesel, gasoline, etc.

Age of Vessel - Less than 5 years, 5-10, 10-15, etc.

Hull Materials - Steel, wood, etc.

Coast Guard Inspected - Applies to U.S. flag tankers, freighters, passenger ships, and ocean going tugs. It does not apply to inland tugs, fishing vessels, or foreign flag vessels.

Person in Charge of Vessel Maneuvers - U.S.C.G. licensed master/pilot, State licensed pilot, foreign master, etc.

GROUP II - TIME, LOCATION, ENVIRONMENT

Year of Casualty

Month of Casualty

Body of Water where Casualty occurred -

Inland - Atlantic, Gulf, Pacific (all waters covered by
Inland Rules of the Road)

Western Rivers (all waters covered by the Western Rivers
Rules)

Gulf Inland Rivers and Waterways

Great Lakes (all waters covered by the Great Lakes Rules)

Ocean - Atlantic, Gulf, Pacific, Caribbean

Ocean - Other

Foreign Waters

Specific Location of Casualty

Coastal Waters - identified by Bowditch number (coastal
segment)

Western Rivers - identified by river name/segment

Gulf Inland Rivers and Waterways/Intracoastal Waterway -
identified by name/segment

Great Lakes - identified by lake/connecting waterways
and nearest degree of latitude, longitude

High Seas - identified by worldwide rectangular grid
(15° longitude x 5°-10° latitude)

Time of Day - Day, Night, Twilight

Weather - Clear, partly cloudy, overcast, fog, rain, snow,
other

Visibility - Less than 1/4 mile, 1/4-1/2 mile, 1/2-1 mile,
1-2 miles, over 2 miles

Wind - Calm, 1-3 kn, 4-10 kn, 11-16 kn, 17-27 kn, etc.

Sea Conditions - Calm, 5-15 ft. swell, 16-20 ft. swell,
21-40 ft. swell, over 40 ft. swell, ice

GROUP III - CASUALTY CHARACTERISTICS

Case Serial Number - assigned in sequence received by fiscal
year

Marine Inspecting Office Investigating Casualty

Type of Investigative Report - Letter of transmittal, narra-
tive, Marine Board

Month Investigation Completed

Nature of Casualty

Collisions - meeting, crossing, overtaking

Collisions - anchored, docking, undocking

Collisions - fog

Collisions - minor bumps tug and vessel

Rammings - fixed objects, offshore rigs

Rammings - floating or submerged objects, ice, aids to
navigation

Explosions/Fires

Groundings - with damage, without damage

Foundering/Capsizings/Floodings

Heavy weather damage

Cargo damage (no damage to vessel)

Materiel failure - vessel structure, machinery, equipment

Other

Cause/Factor

Personnel fault - licensed master, pilot, foreign
master, etc.

Storms/Heavy weather/Adverse weather

Unusual currents

Sheer/Suction/Bank Cushion

Depth less than charted
Restricted maneuvering room
Structural failure
Equipment failure
Unseaworthy/Improper Maintenance
Fault other vessel/personnel
Floating debris/submerged object
Insufficient horsepower/Inadequate tug assistance
Unknown/Other

Area of Causal Connection/Additional Contributing Factors

Hull
Steering gear
Diesel engines
Propellers
Pumps
Boilers
Navigation equipment, etc.

Rules of Road Violations - rule number, comments

Number of Deaths/Injuries - crew, passengers, dock workers,
others

Estimated Dollar Value of Loss/Damage - vessel, cargo,
other property

Vessel Total Loss

Special Indicator - degree of oil pollution, bridges/locks/
dams involved, etc.

APPENDIX C

INDEX AND LISTING OF THE DATA BASE CASES

Period Covered: FY 1972 - FY 1977.*

Number of incidents:

55 Groundings	(47 Tank Vessel, 8 Non-Tank Vessel)
17 Collisions	(10 Tank Vessel, 7 Non-Tank Vessel)
6 Rammings	(6 Offshore Rigs)
78 Total	(63 Tank Vessel/Offshore Rigs, 15 Non-Tank Vessel)

* FY 1976 contained 15 months.

GROUNDING CASE NO.	DATE	LOCATION	LATITUDE N	LONGITUDE W	DIST SHORE OF (MI)	TYPE VIS (MI)	VESSEL NAME	VESSEL TYPE	FLAG	GROSS TONS	CARGO TONS	SPILL TOBS (KTONS)	
													SHORE OF (MI)
1	20783	11/01/71	OFF DELA. BAY	38-49.8	74-59.1	5	DAY 5	BARHATTAN	TANKER	USA	60.9	NONE	-
2	21206	3/01/72	OFF DELA. BAY	38-36.	74-52.	11	DAY 5	SOHIO RESOLUTE	TANKER	USA	37.8	CRUDE	75
3	21434	3/21/72	L.I. SOUND	41-17.0	72-08.2	1	NGT 6D	F.L.HAYES	TANKER	USA	1.1	82 OIL	0
4	21473	3/05/72	OFF CHES. BAY	36-58.	75-57.5	3	DAY 1.5	FALCON LADY	TANKER	USA	20.8	CRUDE	20
5	21566	4/02/72	OFF TAMPA BAY	27-36.4	82-54.3	8	NGT 15	MARINE DUVAL	TANKER	USA	11.1	LIO SULPH 23.3	0
6	21580	4/16/72	GULF OFF SABINE	29-30.5	93-44.	12	NGT 15	OVERSEAS ALASKA	TANKER	USA	34.4	CRUDE	20
7	21840	5/21/72	GUAYABILLA PR	17-58.05	66-45.8	1	NGT 15	PREDDON	TANKER	LIB	23.1	CRUDE	36.2
8	*22310	6/28/72	CAPE LOOKOUT NC	34-31.	76-29.2	7	TWI 5	PRESIDENT ADAMS	FREIGHTER	USA	9.1	(GENERAL)	-
9	30027	7/01/72	OFF CHES. BAY	36-54.2	75-52.2	5	NGT 1.5	ATLANTIC CONQU.	TANKER	USA	18.8	NAVY DIST	30
10	*30315	8/13/72	CAPE LOOKOUT NC	34-29.5	76-28.6	8	DAY 10	HORDA	FREIGHTER	USA	5.8	(GENERAL)	-
11	30367	7/22/72	HUSSET SOUND RE	43-40-42	70-10-53	1	NGT 10	TAMBO	TANKER	MOR	47	85 OIL	82.1
12	*31032	10/07/72	OFF L.A. HARBOR	33-42.04	118-17.21	2	NGT 15	LIBERTY MANUFACT.	FREIGHTER	PAN	8.2	85,86OIL	-
13	*31776	2/08/73	SAN JUAN HARBOR	18-28.5	66-07.43	1	NGT 10	MIBERYA	FREIGHTER	GRE	6.1	(SYNCL)	-
14	32647	4/06/73	TALLABOA BAY PR	17-57.83	66-44.93	2	NGT 5	TELINAY	TANKER	USA	13.8	NONE	-
15	32733	12/26/72	L.I. SOUND	41-15.85	72-20.59	1	NGT 6.5	CONECTICUT	TANK BARGE	USA	2.5	85 OIL	4
								MARCI MORAN	TUG	USA	.2	NONE	.05
16	40023	5/17/73	LIMETREE BAY VI	17-40.63	64-44.3	2	DAY 12	EUGENIE LIVANUS	TANKER	LIB	129.3	CRUDE	182
17	40334	3/07/73	COLD BAY AK	55-07.3	162-31.3	1	NGT 7	HILLYER BROWN	TANKER	USA	10.6	JET,DIERSL	18.5
18	40474	8/26/73	GUAYABILLA PR	17-58.42	66-45.75	1	TWI 10	SABINE	TANKER	USA	17.8	NAFPA	25.7
19	40685	8/24/73	GULF OFF LA	29-16.5	93-39.5	30	DAY 5	BALTI MORE TRADER	TANKER	USA	31.1	JET,HEATG	55.5
20	*41539	12/08/73	OFF PN EVER FLA	26-07-5	80-05-5	1	DAY 0	FEDERICO C.	PASSENGER	LYA	20.4	NONE	-
21	*41618	2/16/74	OFF OC. CITY MD	37-58.0	75-08.5	7	DAY 8	MERRIAC	BULK CARR.	USA	16.0	NONE	-
22	41841	3/06/74	OFF ELANI	25-58.4	80-06.2	1	NGT 10	UHL COYORUO	TANKER	USA	16.9	NOIK	-
23	42500	5/12/74	OFF DELA. BAY	38-41.7	74-44.8	15	DAY .5	CHRISAWBY	TANKER	PAN	20.8	CRUDE	48
24	42639	4/17/74	GUAYABILLA PR	17-57.96	66-45.55	1	NGT 6	MARINE HOPE	TANKER	PAN	18.1	NAFPA	24
25	43131	11/17/73	GULF OF MAINE	43-47.5	69-17.2	8	NGT 10	HOT OIL #17	TANK BARGE	USA	1.1	NONE	-
								J.H.DEIMLEIN	TUG	USA	.1	NONE	-
26	43365	8/23/73	GUAYABILLA PR	17-58.13	66-45.7	1	NGT 10	CALIFORNIA	TANKER	USA	8.5	CELR MCS	3.9
27	50972	11/12/74	LA PARGUERA PR	17-55.2	67-04.7	3	NGT PR	DAPHNE	TANKER	LIB	38.9	CRUDE	45.8
28	51305	10/23/74	OFF DELA. BAY	38-39.55	74-48.5	13	TWI 10	TEXACO CALIFORNIA	TANKER	USA	23.5	FUEL "C"	39.6
29	51736	12/10/74	L.I. SOUND	41-11.05	72-27.6	5	DAY 5	CLUDE CURWAY	TANKER	PAN	26.6	85 OIL	43
30	51949	8/08/75	VIRGIN ESG PR	18-13.8	65-33.6	3	NGT 10	BARBARA MORGAN	TUG	USA	.2	NONE	-
31	52210	4/26/74	GUAYABILLA PR	17-57.97	66-45.65	1	NGT UNK	MARINE HOPE	TANK BARGE	USA	2.3	GASOLINE	4.7
32	52331	4/07/75	DELAWARE BAY	38-52.5	75-07.5	4	NGT UNL	TEXACO WISCONSIN	TANKER	USA	20.3	NOIK	-
33	52502	1/22/75	LIMETREE BAY VI	17-40.1	64-44.3	1	DAY UNL	RICHARD C. LEHOS	TANKER	GRE	113.5	CRUDE	193.9
34	52803	6/07/75	GULF OFF ARAMSS	27-49.	97-01.	2	NGT 6D	PHILLIPS OREGON	TANKER	LIB	51.5	CRUDE	80
35	60000	12/15/76	NANTUCKET SHOAL	41-02	69-27.5	29	NGT 8	ARGO MERCHANT	TANKER	LIB	15.	86 OIL	27.6
36	60554	10/10/75	OFF DELA. BAY	38-49.6	75-01.	4	NGT 10	TEXACO CALIFORNIA	TANKER	USA	23.5	GASOLINE	39
37	60761	5/11/75	L.I. SOUND	41-17.	72-06.	1	DAY 1	POLING BROS #7	TANKER	USA	1.2	GASOLINE	2
38	61142	12/23/75	OFF DELA. BAY	38-47.9	75-00.8	4	DAY UNL	UNIVERSAL APOLLO	TANKER	LIB	72.1	CRUDE	119
39	62407	4/30/76	GUAYABILLA PR	17-58.8	66-45.9	1	NGT UNK	SERRA TRADER	TANKER	LIB	28.0	TOLOMER	3
40	62508	3/14/76	L.I. SOUND	40-49.	73-46.	1	NGT 10	UCAM STAR	TUG	USA	.2	NONE	-
								BARGE RICHMOND	TANK BARGE	USA	2.7	GAS	59
41	62934	5/01/76	OFF CHES. BAY	36-53.1	75-51.7	7	DAY 2	EXXON HUGHSON	TANKER	USA	34.8	JET,DIERSL	62.8
42	63247	5/28/76	LIMETREE BAY VI	17-39.8	64-50.2	2	NGT 6D	KATINA	TANKER	GRE	15.8	NOIK	-
43	63777	8/26/76	OFF DELA. BAY	38-42.	74-47.	13	NGT 7	MONTICELLO VCTRY	TANKER	USA	28.5	82 OIL	46
44	63792	7/18/76	OFF DELA. BAY	38-48.1	75-01.0	4	NGT 15	OLYMPIC CHALLENGER	TANKER	LIB	38.0	CRUDE	37.3
45	63810	8/01/76	GUAYABILLA PR	17-59.3	66-46.5	1	NGT 8	OVERSEAS ALBERTIAN	TANKER	USA	21.5	NOIK	-
46	64173	4/13/76	OFF CHES. BAY	36-54.0	75-52.6	5	NGT 15	THOMAS H	TANKER	USA	17.7	(GRAIN)	-

-- GROUNDINGS --

- Groundings (cont.) -

GROUNDING NO.	CASE NO	DATE	LOCATION	LATITUDE		LONGITUDE	DIST TIME VIS		VESSEL NAME	VESSEL TYPE	FLAG	GROSS TONS	CARGO	CARGO SPILL
				N	W		(MI)	(HR)						
47	*70272	12/07/76	GULF OFF SABINE	29-37	93-50	4	NCT	UNK	CIUDAD DE PASTO	FRIGHTER	COL	5-2	(GENERAL)	-
48	70471	11/23/76	GULF OFF LA	29-22.5	93-13.0	24	DAY	19	RAIDENITE	TANKER	USA	19-8	LUBE OILS	31.7
49	*70814	2/10/77	OFF CHES. BAY	36-57.0	75-55.3	3	NCT	15	THORUNN	BULK CARR.	MOR	23-7	(GRAIN)	-
50	70939	2/16/77	TALLAPOA DAY	PR 17-58.6	86-44.13	2	DAY	GD	RUBIOSE	TANKER	MOR	2-0	NONE	-
51	71214	11/20/76	OFF L.A. HARBOR	33-42	118-17	1	DAY	PR	LAKE PALOUDE	TANKER	LIB	61.3	CRUDE	114.5
52	71355	10/05/76	COOK INLET AK	60-48.9	151-29	5	DAY	8	SEALIFT PACIFIC	TANKER	USA	17-1	JP-4 JET	22.4
53	72865	9/19/77	OFF DELA. BAY	38-47.9	75-00.8	3	NCT	2	WESTERN ETHICS	TANKER	SIN	51-5	CRUDE	90.5
54	72904	6/30/77	FLORIDA STRAITS	25-24	80-08	5	NCT	UNK	BLAZARBEH S	TUG	USA	3-6	ASPHALT	5.6
55	73579	12/28/76	GUAYANILLA PR	17-57.8	66-45.9	1	NCT	10	DAPHNE	TANKER	LIB	30-9	CRUDE	56.7

COLLISION CASE NO.	DATE	LOCATION	LATITUDE N	LONGITUDE W	DIST H	TIME VIS SHORE OF (MI)	VESSEL NAME	VESSEL TYPE	FLAG	GROSS TONS (KTONS)	CARGO (KTONS)	CARGO SPILL (KTONS)	
													DAY
1	20123	6/06/71	L.I. SOUND	40-51.	73-45.5	1	NGT	UNL	MOBIL 8	USA	.2	NONE	0
									TUG	USA	2.1	NONE	0
									TANK BARGE	USA	1.5	GASOLINE	0
2	*21032	12/23/71	OFF N.J.	39-33.	73-44.	25	NGT	10	LUG-DAG	USA	2.6	NONE	0
									CAPTAIN SAH	USA	2.6	NONE	0
									FRIGHTER	USA	7.9	(GENERAL)	-
3	*21230	12/10/71	OFF SAVANNAH GA	31-58.83	80-42.25	10	DAY	-3	GUADALUPE	USA	10.2	(GENERAL)	-
									HYDRO SHIP	USA	7.9	(GENERAL)	-
									EXPORT BUILDER	USA	7.9	(GENERAL)	-
4	21488	11/18/71	OFF SF HARBOR	37-45.9	122-39.6	5	NGT	17	PESEPOLIS	USA	33.5	NONE	-
									TANKER	USA	7.7	(FRIGHT)	-
5	*30620	9/04/72	JUAN DE PUCA CN	38-18.9	123-39.8	5	NGT	-5	ANGSAN SEA	USA	11.3	NONE	-
									FRIGHTER	USA	12.7	(GENERAL)	-
									C.E. DANT	USA	11.7	(GENERAL)	-
6	*31598	9/14/72	OFF C. MATTHEAS	35-22.2	75-15.5	15	DAY	12	YANSHAWALI	USA	13.5	(GENERAL)	-
									FRIGHTER	USA	13.5	(GENERAL)	-
									REP. DR COLOMBIA	COL	13.5	(GENERAL)	-
7	*31650	1/01/73	GULF OFF MISS R	28-53.	89-03.	15	NGT	8	MINILEAGUN	GRB	5.9	NONE	-
									GLORAR GRAND BKS	VSL	2.2	NONE	-
8	31651	12/10/72	GULF OFF LA.	29-24.	93-14.5	24	DAY	1	LAV BARGE 21	USA	2.2	NONE	-
									TUG	USA	2.2	NONE	-
									BETTY G.	USA	16.6	DIES.FUEL	23.1
9	*32626	6/05/73	JUAN DE PUCA US	48-23.5	124-22.8	5	DAY	-25	ORIENTAL MARINER	PAN	14.2	(GENERAL)	-
									TANKER	USA	13.6	NONE	-
10	32947	3/07/73	GULF OFF LA	28-30.	93-18.	90	DAY	-12	ADABELLE LIXES	USA	9.3	(GENERAL)	-
									FRIGHTER	USA	12.6	GASOLINE	3.1
									AMOCO LOGISTANA	USA	4.2	(GENERAL)	-
11	*40953	6/26/73	OFF AT. CITY NJ	39-13.	74-10.	15	NGT	-25	GOLAR TRYG	USA	11.3	(GENERAL)	-
									FRIGHTER	USA	9.9	NONE	-
12	51562	11/02/74	OFF TAMPA BAY	27-37.	82-48.	8	NGT	10	CAROLE G IEGHAN	USA	9.9	NONE	-
									TUG	USA	9.9	NONE	-
									IOS 3302	USA	9.9	NONE	-
									THOMAS ST PHILIP	USA	9.9	NONE	-
13	60769	4/22/75	GULF OFF LA	28-58.	89-29.	5	DAY	7	CITY OF PENSACOLA	USA	9.9	PROP. GAS	2.5
									TANK BARGE	USA	2.5	PROP. GAS	2.5
									DONAR COMMANDER	USA	1.5	NONE	-
									TUG	USA	21.5	CRUDE	35.3
									ALCAID	ITA	21.5	CRUDE	35.3
14	62102	12/04/75	OFF CHES. BAY	36-56.6	75-58.2	2	DAY	-1	DREYANG PROSPRYA	PAN	33.7	NONE	-
									TANKER	USA	19.3	(CORB)	-
									VANTAGE HORIZON	USA	20.7	NONE	-
15	62977	11/05/75	GULF OFF LA	28-05.	92-46.	108	NGT	13	CHRISTINA D'AMICO	USA	9.1	NONE	-
									TANKER	USA	9.1	NONE	-
									ANTHONY ST PHILIP	USA	9.1	NONE	-
16	63289	4/28/76	OFF N.Y. HARBOR	40-16.5	73-44.	15	NGT	12	SPARKLING WATERS	USA	2.8	(CH.FSTB)	-
									TANK BARGE	USA	2.8	(CH.FSTB)	-
									YAMASHI	COL	1.6	(GENERAL)	-
									TUG	USA	2.2	NONE	-
									CRENSADER	USA	1.8	NONE	-
17	64027	4/22/76	L.I. SOUND	40-51.57	73-44.05	1	NGT	PR	POLLING BRS.#23	USA	8.5	95,000L	14.7
									TANK BARGE	USA	8.5	95,000L	14.7
									OCEAN PRINCE	USA	2.2	NONE	-
									TUG	USA	2.2	NONE	-
									NEPCO 112	USA	2.2	NONE	-
									CHRISTINE E.	USA	2.2	NONE	-

-- COLLISIONS --

RAMMING CASE NO.	DATE	LOCATION	LATITUDE N	LONGITUDE W	DIST SHORE OF (MI)	TIME VIS (MI)	VESSEL NAME	VESSEL TYPE	FLAG	GROSS TONS	CARGO	CARGO SPILL (KTQMS)
1	21966	5/02/72 GULF OFF LA	29-03	89-47	13	DAY	UNL CAPTAIN CARL BAR 299	TUG BARGE	USA	.2	WQE (STEEL)	-
2	32936	6/08/73 GULF OFF MS	29-37.78	88-42.1	45	NET	W.D. 40-B ECUADOR HARU	OIL STRUCT REEF. CARR	USA JAP	5.0	CRUDE NONE	0
3	42909	4/19/74 GULF OFF LA	28-51	91-54	40	DAY	UNL OCS 0781 WLS 3+3D GAS WELLS	OFFSH PLAY	USA	-	CRUDE GAS	0
4	50920	5/08/74 GULF OFF LA	28-17.50	91-42.57	75	NET	10 FOREST 112-7 BORTHIND	RIG	USA	.2	CRUDE NONE	0
5	53143	6/08/75 GULF OFF LA	29-23.98	93-16.99	30	NET	10 KAPETAN XILAS OCS-G-1997 PLFF.C RIG	FREIGHTER	GER	11.3	(GENERAL)	-
6	60909	8/15/75 GULF OFF LA	28-21.10	93-02.85	90	NET	10 GLOBTIAK SUN W/C 53WA	TANKER RIG	BAH USA	33.5	CRUDE	2.7
											CRUDE	0

-- RAMMINGS --

*Cases not involving tankvessels or offshore rigs.

APPENDIX D VESSEL TRAFFIC SERVICES

D.1 BACKGROUND

A vessel traffic service (VTS) is defined in this study as an integrated system encompassing the variety of technologies, equipments and people employed to coordinate vessel movements in or approaching a port or waterway. The first VTS of any consequence was the system installed for the Port of Liverpool, England, in mid 1948. This system pioneered the use of shore-based radar and VHF communications to assist vessels entering port.

By 1964, the ports of Hamburg and Rotterdam both had fully developed systems in operation, each comprised of a series of shore-based radars and a VHF communications network. These systems have been successful in reducing accidents. The rate of vessel collisions in the approach to Rotterdam was reduced fourfold, in spite of significant increases in port tonnage generated by the rapid economic expansion of the Common Market.

Canadian authorities report that since the inception of their traffic control system on the St. Lawrence Seaway in 1968, the number of collisions has been reduced to an average of three per year, compared to an average of 12 serious collisions per year recorded during the period 1964-1967.

The United States, despite the large number of ports and a high volume of waterborne commerce, has been quite conservative toward entry into systems intended to provide some form of marine traffic control.

Table D-1 is a list of some rather basic traffic systems that were being operated in United States ports and waterways prior to 1972. The only Coast Guard operation was in the St. Marys River. Legislation for this dates back to 1896.

TABLE D-1. EXISTING VESSEL TRAFFIC SYSTEMS IN U.S. PORTS AND WATERWAYS PRIOR TO 1972

Port or Waterway	Type	Operator
St. Marys River	Vessel Movement Reporting System (VMRS), TV	U.S. Coast Guard
New Orleans	Traffic Lights	Corps of Engineers
Cape Cod Canal	Traffic Lights, VMRS, Radar and TV	Corps of Engineers
Chesapeake & Delaware Canal	Traffic Lights, VMRS TV	Corps of Engineers
St. Lawrence Seaway	VMRS	St. Lawrence Seaway Development Corp.
Honolulu	Signal Tower	Harbor Master
Los Angeles/Long Beach	Harbor Radar, teletype net	LA/LB Pilots
Baltimore	VHF-FM Communications	Private
Portland, Oregon	VHF-FM Communications	Private
Boston	VMRS	Private

In November 1968, the Coast Guard formulated plans for a Harbor Advisory Radar Project. In January 1970, the Coast Guard began operating the San Francisco Harbor Advisory Radar Project on an experimental basis.

In July 1971, the Coast Guard Office of Marine Environment and Systems was established. One function of this office was to prepare and implement a national plan for vessel traffic systems.

On 10 July 1972, the Ports and Waterways Safety Act (PL 92-340) was signed into law by the President. This authorized the Secretary of the Department of Transportation and through him the U.S. Coast Guard to establish, operate and maintain vessel traffic services and systems for ports, harbors and other waters subject to congested vessel traffic. Since 1972 the Coast Guard has

commissioned five major services located in San Francisco, Houston-Galveston, Puget Sound, Price William Sound (Valdez), and New Orleans.

D.2 CASUALTY CONSIDERATIONS

A summary of casualty data for fiscal years 1968 through 1971 is shown in Table D-2. Collisions, rammings and groundings are potentially preventable by vessel traffic systems. In fiscal year 1971 alone, there were 1460 accidents of this type that resulted in \$31.2 million dollars damage to vessels, \$1.9 million dollars damage to cargo and \$8.5 million dollars damage to other property. In addition, 75 persons were killed and 62 injured.¹

In calendar year 1971 there were 116 polluting incidents caused by collisions or groundings, which spilled 2.35 million gallons of pollutants into U.S. waters.² Much of the active pressure for vessel traffic services stems from the need to reduce pollution caused by shipment by water of petroleum and other hazardous polluting substances.

D.3 SERVICES AND FUNCTIONS

D.3.1 Services

Vessel Traffic Services (VTS) being implemented under the authority of the Ports and Waterways Safety Act of 1972 (Public Law 92-340) encompass a wide range of techniques and capabilities primarily aimed at preventing vessel collisions, rammings, and groundings in the port and waterway environment. They are also designed to expedite ship movements, increase system capacity, and improve all weather operating capability. Based on local needs and safety requirements, such services may vary in design

¹U.S. Coast Guard Commercial Vessel Casualty Reports, FY 1971

²U.S. Coast Guard Pollution Incident Reports, CY 1971

TABLE D-2. ANNUAL CASUALTY TOTALS FOR COLLISIONS, RAMMINGS, AND GROUNDINGS
(C/R/G), FY 1968-71 (1)

	FY '68		FY '69		FY '70		FY '71	
	Cases	Vessels	Cases	Vessels	Cases	Vessels	Cases	Vessels
Total Casualties, All Types	2,570	4,011	2,684	4,183(1)	2,582	4,063	2,577	4,152
Collisions/Rammings	1,047	2,221	1,109	2,336	1,163	2,271	1,119	2,349
Groundings	525	656	567	690	540	670	604	807
C/R/G Subtotal	1,572	2,877	1,676	3,026	1,703	2,941	1,723	3,156
CRGs as % of Total	61.1%	69.3%	62.4%	72.4%	65.8%	71.6%	66.9%	76.0%
Location	CRG Cases	% of All CRGs	CRG Cases	% of All CRGs	CRG Cases	% of All CRGs	CRG Cases	% of All CRGs
All U.S. Waters	1,342	85.4%	1,274	76.1%	1,307	76.7%	1,460	84.8%
Inland-Atlantic	299		388		307		386	
Inland-Gulf	511		406		502		568	
Inland-Pacific	211		189		180		189	
Coastal Subtotal	1,021		983		989		1,143	
Great Lakes	141		130		132		133	
Western Rivers	180		161		186		184	
Estimated Losses (\$ Thousands)	CRGs	CRG% of Total	CRGs	CRG% of Total	CRGs	CRG% of Total	CRGs	CRG% of Total
Vessel	23,895		29,041	42.6%	27,646	39.9%	31,155	39.5%
Cargo	1,300		1,923	17.8%	4,116	23.7%	1,910	28.8%
Property	7,927		7,190	90.8%	9,325	87.8%	8,492	95.3%
Total	42,122		38,054	55.8%	41,087	42.2%	41,557	43.9%
Persons Killed/Injured	33/32		98/88		24/26		75/62	
Cases with Person K/I	27		47		33		53	

NOTES: (1) Casualty tape lists only 4180 vessels for 1969. All other totals in Statistical Summaries agree with tape totals.

and complexity from passive services such as traffic separation schemes and regulated navigation areas to manned services with communications, electronic surveillance, and automated capabilities. Although the specific services vary from area to area, nearly all the services of any VTS, present or planned, are included in Table D-3.

A VHF-FM communications network forms the basis of most major services. The services listed under "Information" in Table D-3 are generally provided each vessel when it enters the VTS area, with updates as needed during transit. Transiting vessels make position reports to an operations center by radiotelephone and are in turn provided with accurate, complete, and timely navigational safety information. The addition of electronic surveillance and computer assisted capabilities allows the VTS to play a more significant role in marine traffic management; thereby decreasing vessel congestion, critical encounter situations, the probability of marine casualty and the resulting environmental damage.

The user community is advised on its privileges and responsibilities through the distribution of printed materials (such as procedures manuals) and through visits by VTS personnel to discuss services with interested persons and groups.

Four of the operational services are described briefly since they represent typical systems of varying degrees of sophistication.

D.3.1.1 San Francisco Vessel Traffic Service

The San Francisco VTS incorporates high resolution radar surveillance of San Francisco Bay and approaches, with a VHF-FM communications network, a vessel movement reporting system, and a traffic separation scheme (TSS).

D.3.1.2 Puget Sound Vessel Traffic Service

The Puget Sound VTS provides coverage of the eastern portion of the Strait of Juan de Fuca, Rosario Strait, Admiralty Inlet, and Puget Sound. This service incorporates a mandatory traffic

TABLE D-3. SERVICES PROVIDED BY A VTS

- INFORMATION
 - Position of Vessels
 - Intentions of Vessels
 - Special Operations
 - Fishing Vessel Traffic
 - Marine Events
 - Towing
 - Dredging
 - Emergency Operations
 - Collisions, Groundings, Fire
 - Spills
 - Search and Rescue
 - Status of Aids to Navigation
 - Hazards to Navigation
 - Weather
- COORDINATION
 - Conflicting Vessel Movements
 - Vessel-to-Vessel Communications
- RECOMMENDATIONS*
- COMMANDS*
 - Conflict Resolution
 - Lane or Channel Stray
 - Separation Assurance
- ANCHORAGE ADMINISTRATION
- ASSISTANCE TO COTP
 - Resolving Emergencies
 - Enforcing Regulations
- OPERATION AND MAINTENANCE OF EQUIPMENT
 - Communications
 - Surveillance
 - Data Management/Computer
- RECORDS
- PUBLIC RELATIONS

*USCG policy is to recommend rather than command. Authority to command exists in VTS's established by Federal Regulations and is generally delegated to the VTS by the COTP in "voluntary" VTS's.

separation scheme and vessel movement reporting system, a VHF-FM communications network, and radar surveillance of high traffic density areas in Admiralty Inlet and Elliott Bay (Seattle Harbor). The traffic separation scheme has been expanded into the Strait of Juan de Fuca as far west as Cape Flattery, in cooperation with Canada.

D.3.1.3 Houston/Galveston Vessel Traffic Service

The Houston/Galveston VTS provides coverage of the Houston Ship Channel from Galveston and its approaches, to Houston, Texas. This service incorporates a vessel movement reporting system VHF-FM communications network and a low light level, closed circuit television surveillance system in the Houston Ship Channel north and west of Morgan Point. A high resolution radar surveillance system covering lower Galveston Bay, Bolivar Roads, and Galveston Bay approaches, and a computerized vessel traffic display system was incorporated into the manned vessel traffic center during 1977.

D.3.1.4 New Orleans Vessel Traffic Service

The New Orleans Vessel Traffic Service (NOLA VTS) has been operational since October 1977, providing a continuous advisory service to vessel traffic on the Mississippi River from the Gulf of Mexico to north of New Orleans at Mile 159 AHP. The service is based on a voluntary Vessel Movement Reporting System in which vessels report their position and intentions at specified locations over VHF-FM Radio-Telephone. Although the Center has no direct surveillance of traffic movement on the River, a sophisticated dead-reckoning computerized display system provides the watchstander with the information needed to monitor the traffic and to give advisories to the vessels.

D.3.2 VTS Functions

By "functions" we refer to what is done by VTS's in order to provide the services noted in Section 2.1. These functions are accomplished by watchstanders and watch officers.

Table D-4 lists the principal watchstanding functions common to all VTS's and some of the principal aids used by watchstanders in accomplishing the functions.

TABLE D-4. BASIC VTS FUNCTIONS AND AIDS

Functions	Aids
<ul style="list-style-type: none"> ● Surveillance <ul style="list-style-type: none"> - Monitoring - Detection 	Radio, Radar, TV, Magnetic Sensor
<ul style="list-style-type: none"> ● Information Processing <ul style="list-style-type: none"> - Identification - Tracking - Extrapolation - Hazard Assessment - Decision Making 	Radio, TV Radar, Plotting Board, Computers Plotting Board, Computers Unaided Watchstander, Computers Standard Operating Procedure (SOP)
<ul style="list-style-type: none"> ● Communication 	Radio, Telephone, Teletypewriter, Direct Voice
<ul style="list-style-type: none"> ● Recording 	Logs, Reports, Cards, Magnetic Tape

Four basic functions are recognized: surveillance, information processing, communication, and recording.

Surveillance involves keeping track of what is happening in the system through monitoring incoming information and detecting information requiring attention. Watchstanders use both hearing and seeing to monitor the system. They listen to all transactions on radio Channels 13 and 16 (possibly also Channel 12 in the future) and detect messages addressed to the VTS or of concern to the VTS (such as a distress call). When such aids are available, they visually monitor traffic in the system as represented on radar displays, television monitors, and indicators for other sensing devices (such as magnetic sensors and radio navigation systems).

Information Processing involves the integration of incoming information from all sources, as well as information in storage in the VTS (e.g., in directives, bulletins, charts, tables, and the watchstanders' memories), to identify and locate positions of

traffic elements, to predict future positions, to assess potential hazards, and to decide what actions are appropriate to the situation.

Identification of vessels in the system is achieved by the watchstander, primarily through radiotelephone communication with the vessel, verified by information reduced from visual displays (radar, TV, etc.), when available.

Tracking (keeping track of present position) and extrapolation of data to determine future positions are accomplished by a variety of techniques, varying from arranging an array of data cards to represent relative vessel positions, through hand placement of vessel models on a plotting board, to reading information from a computer-prepared situation display. Tracking (by human or computer) may be accomplished by dead-reckoning or by continuous following of radar returns. Aids to extrapolation include simple dead-reckoning devices, calibration marks on vessel models, or complex electronic digital computers.

Similarly, a watchstander may estimate hazardous developments by eye from the plots and displays, or a computer may calculate and display such indices as closest point of approach (CPA) or time to CPA (TCPA).

Decisions are always human functions, deriving from regulations, standard operating procedure (SOP), and the judgement of the watchstander (based on training and experience). Decisions generally lead to provision of one or another of the services described in Section 3.1.

Communication is primarily by human voice and, when outgoing, constitutes the act of providing most VTS services. The principal means of communication with vessels in the VTS area is the radiotelephone. Communication with other agencies may be by telephone or teletypewriter, or (when not urgent) by written reports. Communication within the VTS is by voice, person-to-person.

Recording is initiated by watchstanders but often continued by clerical or other personnel. In all VTS's the Watch Supervisor is responsible for maintaining a log of traffic during the watch,

and often several additional logs are maintained, from some of which daily reports to other agencies may be prepared. Generally, too, a data card is maintained for every vessel on which identifying information and major events and times are entered, mostly by hand.

Although all functions are performed at all VTS's, the way in which they are performed and the aids available may vary considerably. Table D-5 illustrates this variability for four VTS's, showing currently operational functions and techniques.

D.4 WATCHSTANDER ACTIVITIES

The services provided by VTS's (Section 3.1) through the performance of a number of basic functions (Section 3.2) are accomplished by assigning various activities (or duties) to duty positions. The principal positions are: Watch Supervisor, Primary Communicator, External Communicator, Radar Monitor, Plotter, and Sector Watchstander. Not all positions are used at all VTS's, as illustrated in Table D-6.

The Watch Supervisor is generally a commissioned officer who is responsible for the total VTS operation during a watch. The Watch Supervisor's duties include supervision of all activities, preparation of a log of activities, and preparation of reports. In unusual or emergency situations, the Watch Supervisor has the authority and responsibility to make necessary decisions and take necessary actions, including issuing of commands to vessels. The Watch Supervisor may, and at least in San Francisco regularly does, perform as a watchstander.

The Primary Communicator talks to the vessels in the system via radiotelephone, receiving information on position and intentions and issuing advisories and other information as required. The Primary Communicator maintains a data card on each vessel transit, entering vessel identification and descriptive data, expected and actual times of arrival at key checkpoints, and such additional information as violations of traffic rules and other unusual events.

TABLE D-5. DIFFERENCES IN FUNCTION MODES AT FOUR VTS's

Function and Mode	Puget Sound	San Francisco	Houston-Galveston	New Orleans
SURVEILLANCE				
Vessel Reporting by Radiotelephone	o	o	o	o
Radar	o	o	o	
Television			o	
INFORMATION PROCESSING				
Tracking and Extrapolation				
Card Array		o	o	
Plotting Board	o			
Radar Plot	o	o	o	
Computer Dead-Reckoning			o	o
Hazard Evaluation				
Watchstander Judgement	o	o	o	o
Computer Assistance			o	o
COMMUNICATION				
Radiotelephone	o	o	o	o
Telephone	o	o	o	o
Teletypewriter	o	o	o	o
RECORDING				
Logs and Reports	o	o	o	o
Manual Entry on Cards	o	o	o	
Time Stamping on Cards	o		o	
Manual Entry into a Computer			o	o
Voice Tapes	o	o	o	o
o = Operational				

TABLE D-6. DUTY POSITIONS AT THREE VTS's

Position	Puget Sound	San Francisco	Houston-Galveston	
Watch Supervisor	X	X	X	
Primary Communicator	X			
External Communicator	X	X	X	
Radar Monitor	X			
Plotter	X			
Sector Watchstander		X	X	

The Primary Communicator continually monitors the traffic situation as presented by available aids and interchanges information with the other watchstanders.

The External Communicator handles telephone and teletypewriter communications, informing the Watch Supervisor and watchstanders as necessary and answering routine inquiries for information from other agencies and the general public. The External Communicator will usually maintain a log of communications, prepare advisories for general broadcasting, and oversee the preparation and filing of magnetic voice and video tapes for VTS records.

The Radar Monitor maintains a continuous watch over traffic as displayed on radar scopes, coordinating the radar information with other plots of traffic and advising other VTS personnel as necessary.

The Plotter maintains a picture of traffic in the VTS area by placing some representation of each vessel in the system on a map or plotting table and regularly updating the positions either by dead-reckoning or from information received from the Primary Communicator, the Radar Monitor and such aids as television monitors. If a model is used to represent each vessel on a plotting table, the Plotter prepares the model, manually entering the necessary data on the model and placing the model on the table. Sometimes the data card is used as a model; sometimes a grease-pencil entry is made on a map or on a radar scope.

The Sector Watchstander does not represent an additional duty position but a different way of dividing duties. If the VTS area is divided into sectors, generally a Sector Watchstander is assigned to each sector. The Sector Watchstander performs all of the monitoring, primary communications and plotting duties for the given sector. An External Communicator position may be maintained in a sectorized center; if not, the Watch Supervisor may perform this function.

VTS watchstanders are trained and qualified for all positions and regularly rotate through all positions during a watch. Thus in actual operations, a single watchstander can be assigned more than one position when traffic is light; or any watchstander may assist at another position if the work becomes heavy there. For example, when traffic is usually heavy in the Puget Sound VTS, the area is divided into two sectors, the Radar Monitor becomes a second Primary Communicator, and the Plotter monitors the radar as well as the plotting table. Similarly, when traffic is very light in the San Francisco VTS, a single watchstander handles all sectors. Such flexibility permits the system to adapt to the traffic conditions, avoiding boredom of watchstanders during quiet periods while avoiding overloading at busy times.

D.5 REFERENCES

1. Vessel Traffic Systems Issue Study, U.S. Coast Guard Final Report, Volume Two, March 1973.
2. Department of Transportation National Plan for Navigation, November 1977.
3. VTS Human Factors Study, D.D. DeVoe, Draft Report, U.S. Department of Transportation, Transportation Systems Center.

APPENDIX E
EASTERN CANADA TRAFFIC REGULATION
"ECAREG"¹

E.1 INTRODUCTION

On Wednesday, February 4, 1970, the Greek tanker Arrow, of Liberian registry, went aground on Cerberus Rock in Chedabucto Bay, Nova Scotia. She was bound for the docks of Canadian Pulp, Ltd., near Port Hawksbury, with a cargo of 16,000 tons of bunker oil. The vessel ran aground in a bay almost completely surrounded by land, thus reducing considerably the dispersion of oil at sea by natural forces. Air and water temperatures were near freezing and thus the oil could not be pumped. The beaches were shingle and boulder which made cleaning very difficult. Pollution clean-up measures cost an estimated \$4.M²;

The vessel ran aground in limited visibility at about 13 knots speed³ on Cerberus Rock, a well marked rock close to a channel five miles wide. No reason was given for the grounding and no distress call was made, merely a wire to the pilot that the vessel would be "a little late arriving."³

An investigation carried out after the Arrow incident revealed, among other defects, that the only radar unit on board was inoperable and that the charts used for navigating the vessel were unsuited to the area in which the ship was operating.

In hind sight, it would have been safer if the vessel had remained 12 miles, or more offshore until visibility permitted the visual identification of conspicuous objects on shore. Additionally, the grounding of the Arrow could have been prevented if

¹W.L. Stuart, Regional Superintendent, Maritimes Region, Presentation File, 8100-7-0; April 3, 1978.

²Communication with Capt. W.L. Stuart, of ECAREG Canada.

³Report on the Sinking of the Tanker "Arrow" by Edison Water Quality Laboratory. NTIS-PB-216-566.

authorities on shore, upon contact with the Arrow while in offshore waters, had introduced other compensatory measures for the vessel's entry into port. This casualty highlighted the need for some system to require vessel masters to advise authorities onshore, in advance of the vessel's arrival, of defective or deficient equipment and other information about the ship's condition to proceed safely to port. In response, the Canadian vessel traffic management system (VTMS), of which ECAREG is the most significant prevention measure, was instituted for eastern Canada.

E.2 THE EASTERN CANADA VESSEL TRAFFIC MANAGEMENT SYSTEM (VTMS)

The objectives of the Canadian VTMS are:

- To facilitate the flow of vessel traffic
- To insure vessel safety
- To protect the Canadian Maritime environment.

The operating components of the Canadian VTMS, all under the authority of the Transport Ministry, Canadian Coast Guard are:

- ECAREG, the Canadian two-way communication system for the clearance of vessel traffic from and to offshore waters outside the 12 mile zone of the Canadian territorial waters.
- The Canadian Traffic Coordination Centers located in Dartmouth, Nova Scotia, St. John's, Newfoundland, and Montreal, Quebec.
- A comprehensive marine communications system which handles almost all civilian and governmental marine communications.
- A pilotage board which is responsible for all pilotage services in Canadian waters.
- Vessel traffic service centers which manage traffic in selected harbor and harbor entrance waterways.
- Aids to navigation in the form of light beacons, RACONS, and buoys.
- Ice breaker service.

All vessel traffic service and traffic coordination centers are manned on a 24-hour basis throughout the year.

The seaward limits of the Eastern Canada Traffic Regulating Zone follow the contour of the 12-mile territorial sea limit beginning at 60°N off the coast of Labrador. The limit is continuous off the east coast of Newfoundland; across the Cabot Strait; along the east and south coasts of Nova Scotia; across the entrance to the Bay of Fundy; and, thereafter follows the U.S.-Canadian border limits to a position in the vicinity of St. Stephens, New Brunswick.

The western limit of the Zone passes through the meridian of 66° 23'W in the Gulf of St. Lawrence.

Figure E-1 depicts the approximate limits of the Eastern Canada Traffic Regulating Zone.

All vessels of 500 gross registered tons and over are covered by the traffic regulations.

Authority is vested in the Canadian Coast Guard to regulate the movement of vessels in waters within the 12-mile territorial sea limits and to enforce regulations applying in these waters. Canadian Coast Guard Pollution Prevention Officers are designated by the Minister of Transport and are authorized to exercise authority outlined in Part XX, section 732 of the Canada Shipping Act.

Within the 12-mile territorial waters of Canada, summary convictions and fines not exceeding \$100,000 are prescribed for persons and/or ships found guilty of violations (Part XX, sections 752, 753, 754 and 755).

With the enactment of the marine environmental law, the ECAREG system in operation, and a number of Vessel Traffic Services operating at major harbors, the Canadian Government has gone a long way in responding to the grounding of the Arrow in February 1970. The integration of all vessel traffic activities under the Canadian Coast Guard has resulted in a highly effective overall Vessel Traffic Management System. The introduction of ECAREG, which is a voluntary system, in July 1976, has been a success in terms of

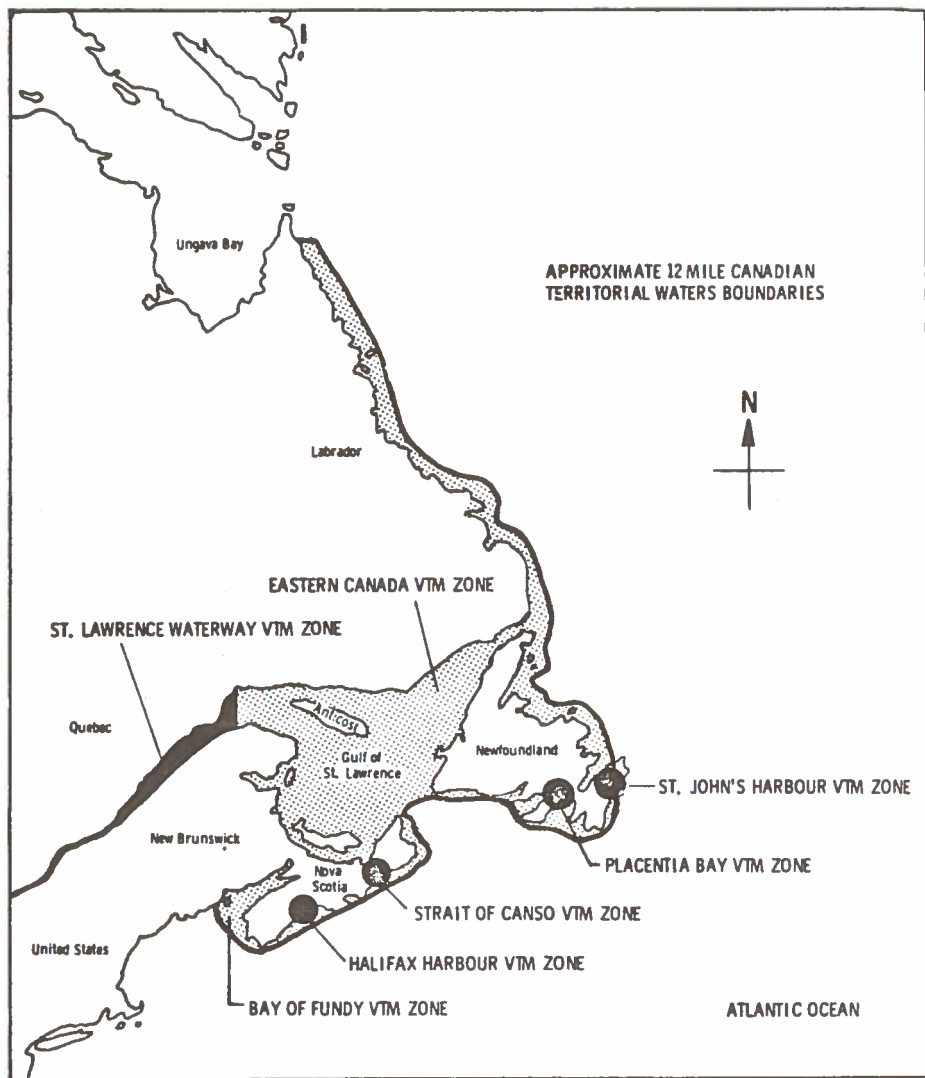

FIGURE E-1. EASTERN CANADA TRAFFIC ZONE

acceptance, cooperation and even praise on the part of vessel operators and the marine industry. The non-cooperative crew or vessel, the "ROGUES" as the Canadians call them, very soon learn that evasion of the rules does not pay. Such vessels are assumed suspect and are inconvenienced by boardings and inspections.

E.3 ECAREG

E.3.1 General

ECAREG stands for Eastern Canada (traffic) REGulation System and is the call sign for the system. ECAREG is the two way reporting and communication system used by the Canadian Coast Guard to monitor and issue clearance to all tankers and vessels, 500 GT or larger entering or leaving the 12-mile Canadian territorial waters.

While the avowed aim of ECAREG is the prevention of vessel casualties and the resulting environmental damage by defective ships, especially loaded tankers, entering the 12-mile Canadian territorial waters, the current ECAREG operation has become the principal bond and backbone of the whole Canadian VTMS. The reasons for this are simple: the information content available to ECAREG, as will be shown later, is such that all components of the VTM System receive handover information and thus are able to plan efficiently their manpower and logistics including emergency operations and contingency measures in the event of an oil spill. At this time the ECAREG clearance system is voluntary. The Canadian Coast Guard personnel believe that it would be better if ECAREG were compulsory.³ It is likely that the present voluntary system will be found very efficient (80% participation in 1977) as time goes on, and the private users see their interest being served by the system.

E.3.2 The Operation

Twenty four hours, or as soon as practicable prior to arrival at the 12-mile zone limit, a radio message is sent from the vessel to ECAREG Canada. The message is a clearance request and contains

the information listed in section 7(3) of Notice to Mariners No. 561/77 as follows:

- a. name of ship and radio call-sign;
- b. name of master;
- c. position and, if applicable, speed;
- d. as applicable, the estimated time of:
 - (i) entry into the Eastern Canada Traffic Zone, or
 - (ii) departure from a berth;
- e. destination, estimated time of arrival and intended route through the Eastern Canada Traffic Zone;
- f. last port of call, if applicable;
- g. draft;
- h. brief description of main cargo and pollutant cargo or dangerous goods by classification;
- i. deficiencies, if any, with respect to the requirements of the Charts and Publications Regulations;
- j. defects, if any, in the ship's hull, main propulsion machinery, steering gear, anchors and cables, radar, compass or essential radio communication equipment;
- k. any release of pollutants from the ship or any damage sustained which may result in pollution;
- l. name of Canadian or United States agent, as applicable; and
- m. date of expiration of the Non-Canadian Ship's Compliance Certificate, if issued (For Tankers ONLY).

Upon receipt of the message, the Coast Guard Traffic Coordination Center (TCC), enters the message data into the vessel information computer system (similar to the Marine Safety Information System MSIS in the U.S.) to check the given vessel and master for records of the past. In addition, the TCC may receive the following information from the central computer:

Vessels underway in the region of interest are listed in alphabetical order, and along side each vessel's name is the position of the vessel; the call sign and marine identifier; the port or country from which the vessel departed and, the vessel's destination and Estimated Time of Arrival (ETA). Vessels which comply with regulation standards for Canadian 12-mile territorial waters are granted clearance and the master is requested to contact, if applicable, the Vessel Traffic Service Center on VHF at a position outside the 12-mile zone.

If a vessel is found non-complying by the TCC, the master of that vessel will be informed of the conditions or provisions under which his vessel could proceed into Canadian territorial waters.

Similar clearance is requested from vessels two hours prior to departing Canadian ports. This clearance is intended to verify that vessels which were conditionally cleared to enter have made repairs and have complied with Canadian regulations.

The ECAREG clearance process does at times involve the use of compensatory measures, when in the judgement of the Canadian Coast Guard there is potential danger above and beyond the non-complying aspect of the vessel or master. Examples of compensatory measures are given below:

- Clearance to enter Canadian Territorial Waters is withheld. Vessel should remain outside Canadian Territorial Waters and await further communication.
- Clearance to enter port is contingent upon your agreement to enter in daylight hours only and in clear visibility.
- Clearance to enter port is contingent upon the Master agreeing to employ the services of two tugs at position indicated.

- Clearance to enter Canadian Waters is contingent upon the vessel rendezvousing with CCG Ship in position indicated. CCG Ship will provide escort to your vessel to position indicated.
- Clearance to proceed from berth is withheld until repairs have been effected to equipment indicated and inspection conducted.
- Clearance is withheld for your vessel to enter Canadian Waters until a technician has been placed on board your vessel and repairs to equipment indicated have been effected.
- Clearance is withheld for your vessel to enter Canadian Waters. Arrangements have been made for a Coast Guard Ship Surveyor to board your vessel at time and position indicated.
- Clearance is given for your vessel to proceed through channel indicated between the hours of ---- and ---- when sufficient depth-under-keel clearance will be available.
- You should proceed to port indicated and there have repairs to equipment indicated carried out to satisfaction of Canadian Coast Guard Ship Surveyor.

The traffic clearance compensatory measures, the 12-mile territorial waters, and the potential imposition of fines of up to \$100,000, are at the core of the casualty prevention protection of the Canadian Vessel Traffic Management system.

E.3.3 Offshore ECAREG Function

It may seem that the planners of the Canadian VTM System have shown little concern for vessel traffic casualties in offshore waters beyond the 12-mile territorial waters. However, ECAREG does accord special handling to large tankers greater than 100,000 DWT when moving towards Canada in offshore international waters. First all vessel traffic is informed of the tanker route and time

of passage, and second, the tanker is informed of vessel traffic and conditions along its route.

E.3.4 The Rogue

Those vessels which do not cooperate with ECAREG are called Rogues by Canadian Coast Guard personnel. There are two kinds of rogues challenging the Canadian VTM system.

- a. Vessels which enter the Canadian 12 mile territorial waters but do not get near the major harbors equipped with offshore radar installations. These are the vessels which are not detected unless they make excessive use of their communication system. They are mainly fishing vessels and do not pose a significant environmental threat. These vessels are looked after by the Canadian Fisheries Service with help from the Canadian Navy.
- b. Vessels which do not receive clearance instructions and yet attempt to enter Canadian harbor facilities or to solicit shorebased support from civilian interests. In time these rogues are detected by the Canadian Vessel Traffic Management System.

The diligence of the Canadian Coast Guard in handling the Rogues is only matched by the diligence and hard work of the Canadian Coast Guard personnel put into their VTM services for the benefit of the 80%⁵ cooperative traffic. The wrath of the Canadian Coast Guard is in fact reserved for those Rogues which either do not make even a feeble attempt at obtaining clearance and/or ignore entirely Canadian Coast Guard instructions. The Rogues must show good faith.

⁵Private Communication with Capt. W.L. Stuart of ECAREG Canada.

The Rogues are caught because the Canadian VTM system is fully integrated, all marine services are under the jurisdiction and management of the Coast Guard and especially including the Pilotage Service. In addition, the Canadian government operates the marine communication system and any communication attempts by the Rogue vessel to obtain private sector support is intercepted and reported to the Coast Guard.

E.3.5 ECAREG Communications

The ECAREG clearance process is implemented mostly by HF radio communications. The HF ionospheric channel does not give reliable communication compared to the VHF line of sight communications or communications through a satellite transponder. Another general difficulty with the communication requirements of ECAREG involves the manning of the radio room on board the vessel. The radio is not manned at all times by all ships while the vessel is in open waters.

However, ECAREG experience with the communications for the 24 hour clearance process is entirely satisfactory in relation to the objectives and the message content of the communications involved.

- The clearance message format listed in section 3.2 looks voluminous but the vessel message is relatively brief because it contains only the positive responses to that format.
- The 24 hour time frame is taken only as a reference time intended to compensate for any communications difficulties. The vessel is required to complete the clearance process prior to crossing the 12-mile boundary. In the limit it is even sufficient that the vessel is aware of ECAREG and, on his own, stops the vessel outside the 12-mile boundary and communicates via VHF with the local Canadian Coast Guard Station.

Communication technology and communication load factors are not an issue in the ECAREG system.

E.3.6 The Marine Industry and ECAREG

Introduction

The genesis and planning of the ECAREG system is a product of common sense used by field personnel of the Canadian Coast Guard in Eastern Canada. The incoming ship and the crew have been through a long voyage, therefore both can use all the help they can get from the shore facilities and personnel.

The Canadian ECAREG provides two positive interactions with the crew:

- a. The 24 clearance exchange between the vessel and the shore system.
- b. The positive contact with Canadian harbor services and facilities outside of the 12 mile limit.

These two positive interactions, coupled with Canadian Coast Guard Compensatory measures, potentially can adapt to any sequence of events that might lead to a vessel casualty.

- The potential accumulated navigation error due to long open water navigation.
- Any potential difficulties with crew and ship.
- Any potential misinformation available to the ships' crew (ex. Charts, notice to mariners).
- Any potential habits of malpractice on the part of the ships' crew or the ships' operator.
- Any 'sudden' changes in the configuration of the harbor and aids to navigation.

The Canadian ECAREG system provides relief from the institutional difficulties among crew, operator, owner and trader:

- The Master is relieved from decision making in his trade-off of time delays versus safety.
- Those owners who value safety can depend on ECAREG to get the crew to practice safety precautions.

Finally, the Canadian Vessel Traffic Management System, including ECAREG, provides the video and/or voice, morse, teletype and other communications records which contribute a major incentive of compliance on the part of all participants.

While many use the phrase 'Human Error' indiscriminately and at times as a slogan for tactical advantage, the Canadians use the ECAREG system to represent the positive response to the "Human Error" factors from the point of view of the State and the protection of the marine environment.

APPENDIX F

THE LORAN-C SYSTEM AND APPLICATIONS TO THE OVTM STUDY

F.1 INTRODUCTION

The LORAN-C system is being examined for possible application to Offshore Vessel Traffic Management (OVTM) and is given special attention in this report for the following reasons:

- a. LORAN-C has been designated as the primary navigation system for the United States Coastal and Confluence Zone (CCZ).¹
- b. LORAN-C coverage is or will soon be available for most of the area of interest for OVTM applications.
- c. One of the ground rules for this study was to assume that all vessels over 1600 gross tons will be required to carry LORAN-C or comparable long-range navigation equipment.

A description of the system, including plans for expansion and expected coverage limitations, is presented in this section.

F.2 GENERAL DESCRIPTION

LORAN-C is a pulsed hyperbolic electronic navigation system that allows a user to determine his position accurately and independent of other equipment. LORAN-C is based on measurement of the difference in time of arrival of pulses of RF energy radiated by a chain of synchronized transmitter stations spaced several hundred miles apart. The effective range (of ground waves) for making a measurement from individual stations is typically 600 to 1400 nautical miles (NM) over seawater, and depends on station power and the capability of the receiver. LORAN-C can be used for navigation in all conditions of visibility and weather. LORAN-C operates in the radio frequency band of 90 to 110 kHz.

Assuming LORAN-C equipment is on-board the vessels navigating in U.S. waters, it may be advantageous to use the vessel position information that is available from the LORAN-C system on these

ships for Offshore Vessel Traffic Management (OVTM) applications. The important factors under consideration in terms of possible OVTM applications are:

- a. coverage, accuracy, and repeatability of LORAN-C,
- b. availability/cost of the various types of shipboard LORAN-C equipment, and
- c. implication of impending navigation requirements for large vessels.

These factors and other considerations are discussed in the following sections.

F.3 LORAN-C COVERAGE

LORAN-C is presently available for position determination over much of the coastal and confluence zone (CCZ). "Available" means that the necessary radiated signals exist for a vessel to detect the master and two secondary stations within a LORAN-C chain and to make a position measurement. This availability is normally identified as coverage, with charts available to show existing LORAN-C coverage. The present coverage areas are depicted in Figures F-1, F-2, and F-3 by the heavy lines. The coverage area indicated in these figures is based on the assumption that the receiver being used can acquire and track LORAN-C signals when the signal to atmospheric noise ratio is at least 1:3. The usable coverage from a LORAN-C chain is determined by the rated power of the stations, atmospheric noise, geometric relationship of the stations, and the specific capabilities of the receiver. LORAN-C signals with signal to noise ratios as low as 1:10 are usable by some receivers but with a loss in accuracy, repeatability and reliability of the measurement. Use of these lower level signals greatly increases the coverage area beyond that shown.

Within the coverage areas shown in Figures F-1, F-2 and F-3, the user can make reliable and repeatable measurements of position with an accuracy of 0.25 NM (2-drms).² The repeatable accuracy

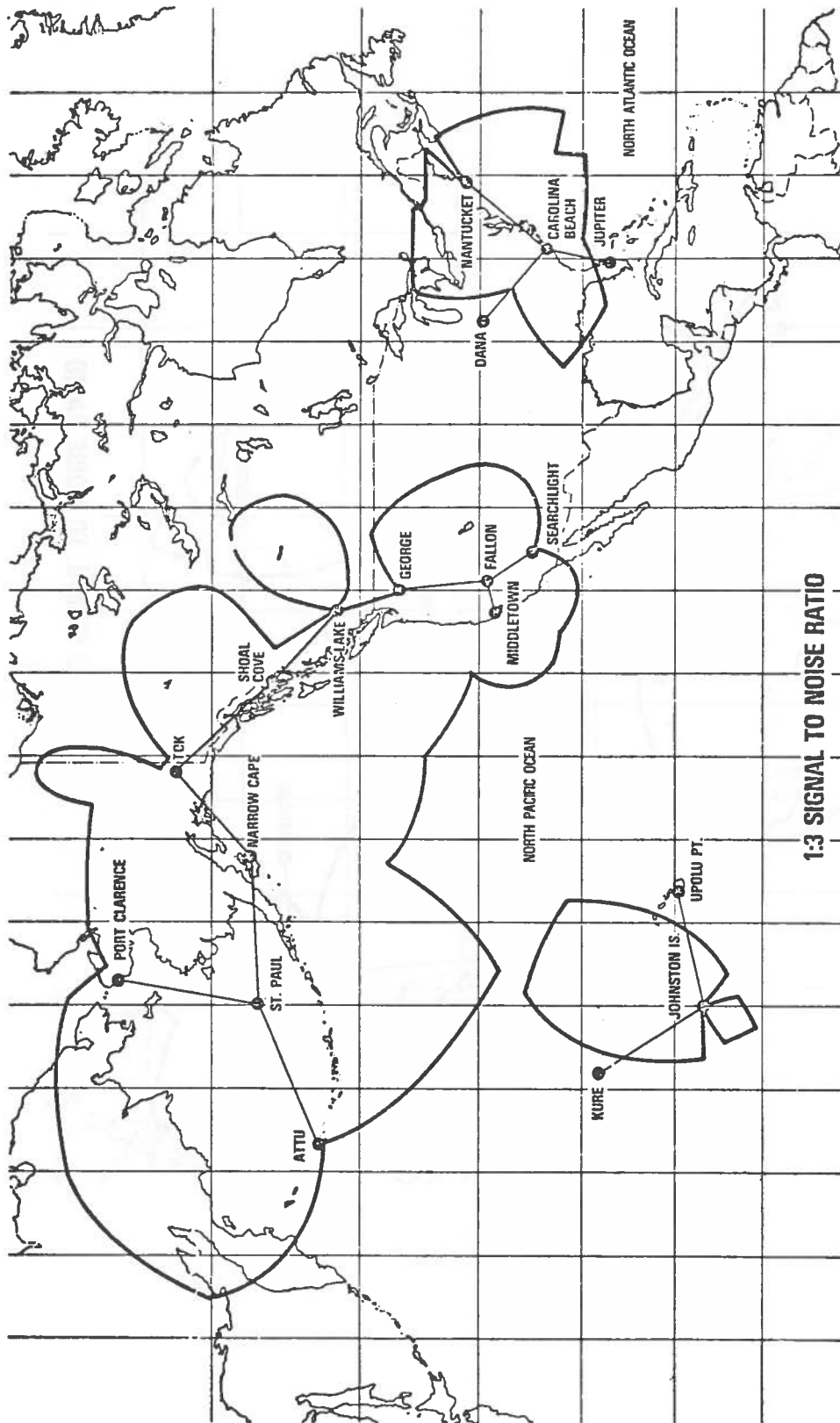

FIGURE F-1. U.S. LORAN-C COVERAGE²

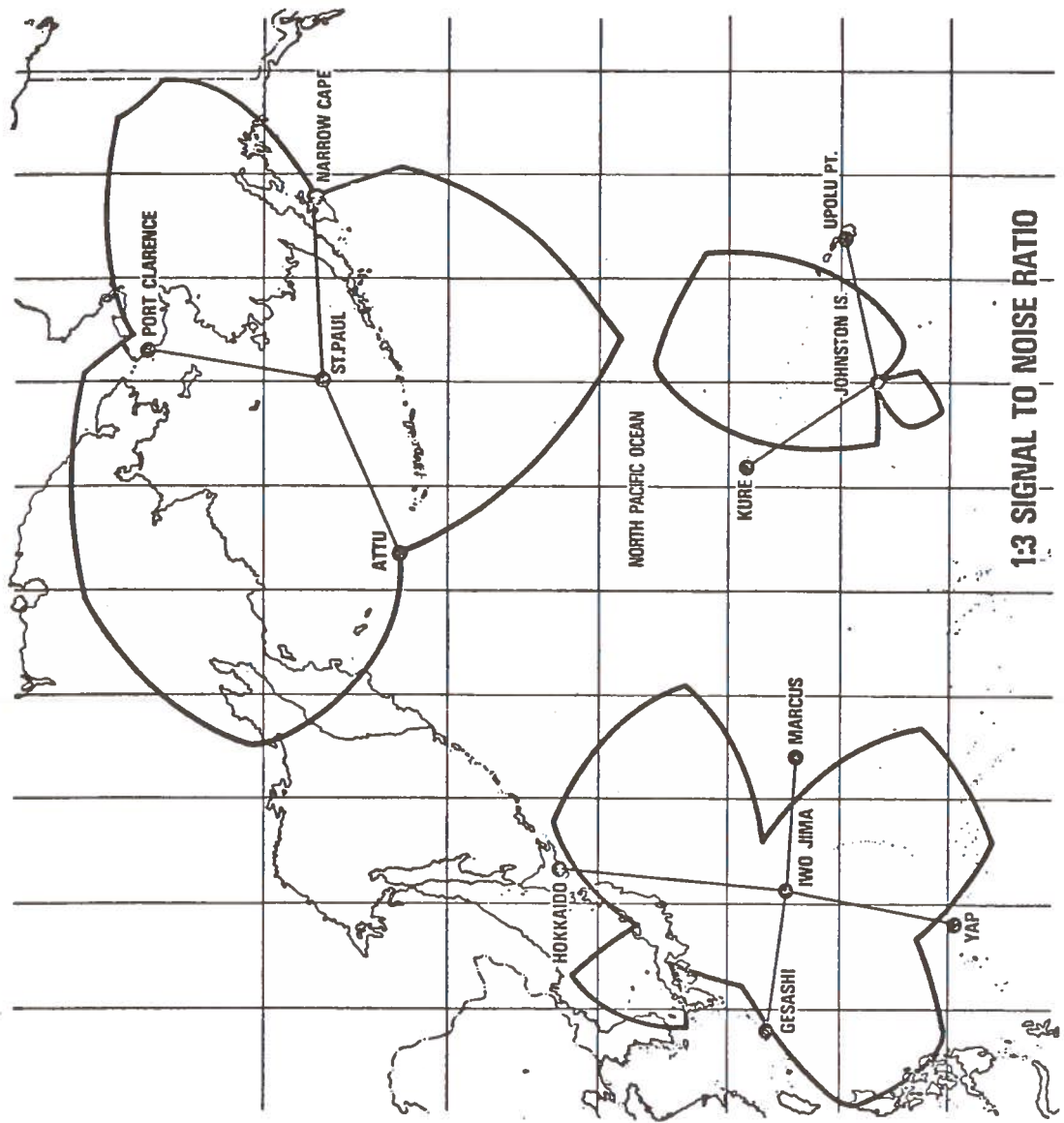

FIGURE F-2. PACIFIC AREA LORAN-C COVERAGE²

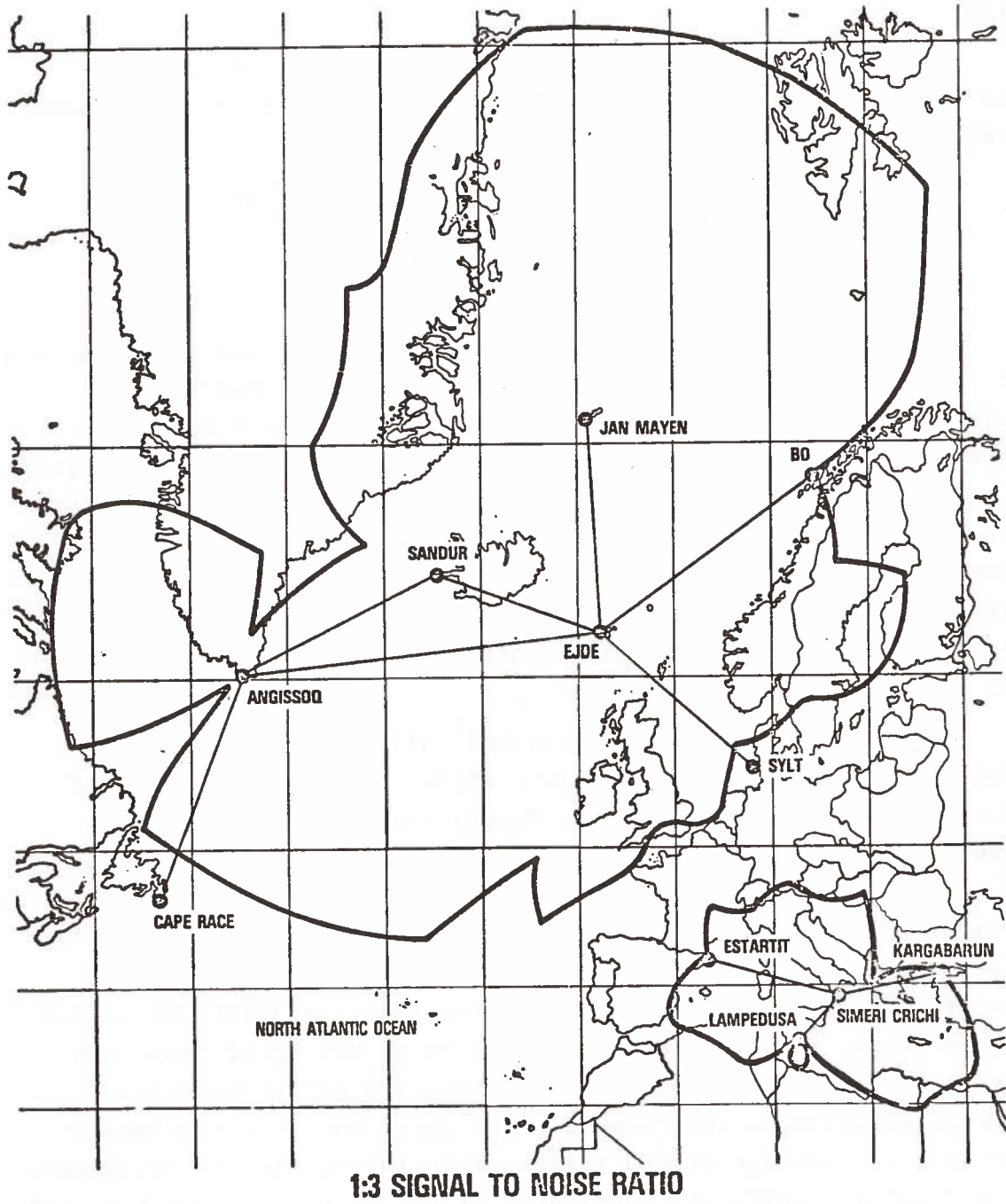

FIGURE F-3. NORTH ATLANTIC AND MEDITERRANEAN LORAN-C COVERAGE²

(ability to return to the same position) of the system is between 60 and 300 feet (2-drms) depending upon location in the service area.

As can be seen LORAN-C coverage presently exists for most of the areas of interest to this study with three notable exceptions, namely, the coastal areas of

- southern Florida and parts of the Gulf of Mexico
- southeast of Hawaii
- Puerto Rico and the Virgin Islands

This situation will change, however, in 1978 and 1979. In mid-1978 two new LORAN-C chains will begin operations and this will significantly improve the eastern and southeastern U.S. LORAN-C coverage. At that time the Northeast U.S. chain and the Southeast U.S. chain will begin operation, with the present East Coast chain remaining on until July, 1979 at which time it will cease operation. The coverage over the eastern half of the country as it will exist in Spring 1980 is shown in Figure F-4. (Refer to the DOT National Plan for Navigation, Report No. DOT-TST-78-4, Nov. 1977 for more information.)

It is clear that the Florida and Gulf of Mexico coverage problems will be solved after July 1978. There are no plans at this time to remedy the Hawaii, Puerto Rico and Virgin Islands coverage void. The radionavigation requirements of these areas are under study.² The present Hawaiian Islands chain will be studied to determine whether the existing LORAN-C coverage of the major islands can be improved enough to justify the cost. The results of this OVTM study indicate the Hawaiian Island area does not currently pose a significant risk of an oil spill from tank vessels. Because of the geographic location of the Hawaiian Islands relative to the commonly used ship routes in the Pacific, the lack of coverage around the Hawaiian Islands is not considered to present a significant likelihood of oil spillage by tank vessels in the offshore waters.

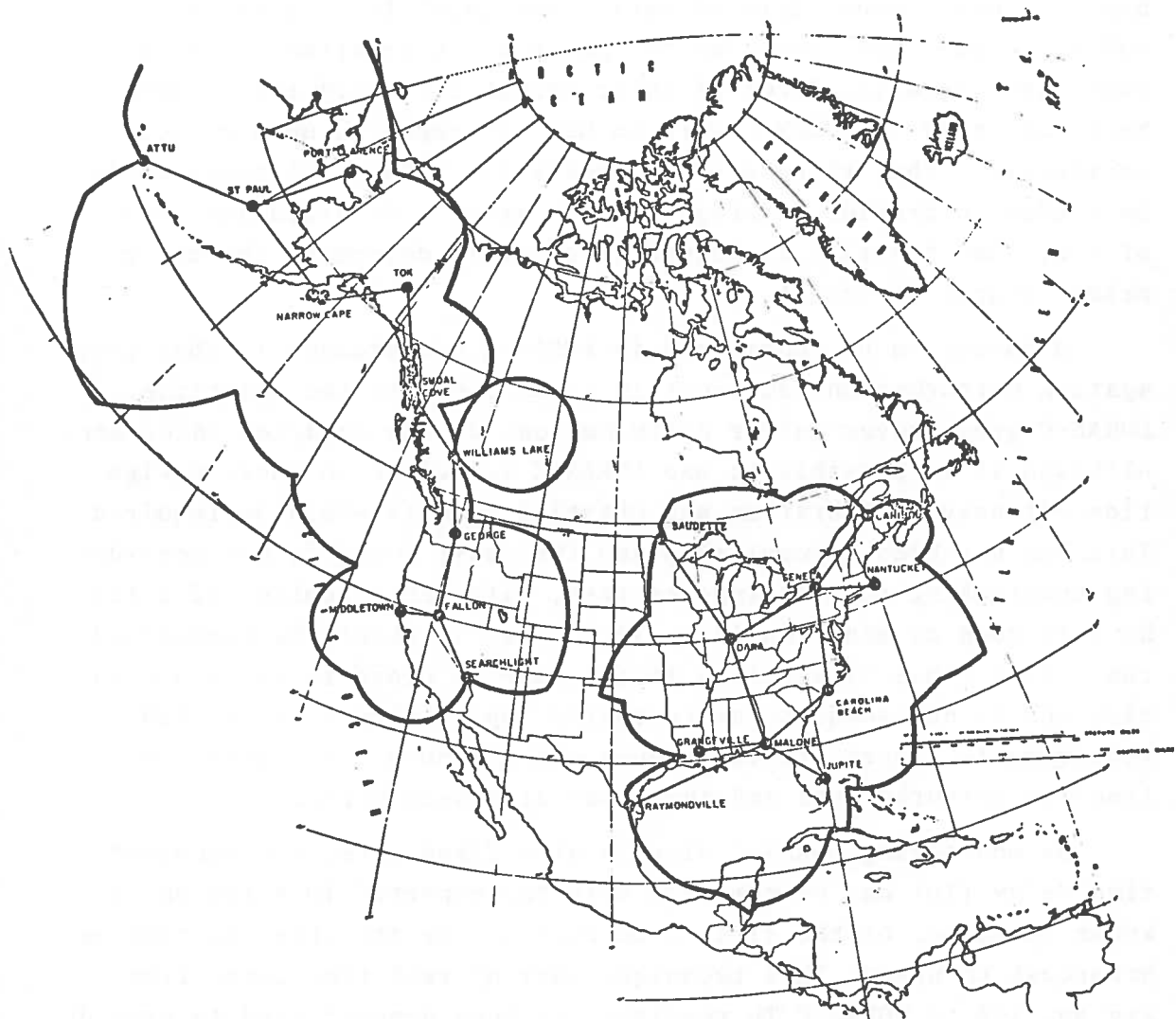

FIGURE F-4. PLANNED U.S. LORAN-C COVERAGE²

However, the study results indicate there is a high risk of oil polluting casualties occurring in the waters offshore of Puerto Rico and the Virgin Islands because of the incidence of casualties in the past and the high volume of traffic. Sixteen of the 55 groundings in the data base (FY72-FY77) occurred in this area. In nine of these cases improved navigation capability, such as LORAN-C, could have provided the position information needed to avoid the casualty. Three of these casualties would likely have been prevented if LORAN-C were in use. It appears, upon cursory examination, that three or four additional LORAN-C stations would be needed to provide coverage in this area. A detailed analysis of costs and benefits is needed in order to determine the appropriate course of action.

A factor to be considered in LORAN-C performance is that propagation perturbations do occur in areas close to the coastline. LORAN-C groundwaves suffer perturbations at the land/sea interface. Although it is possible to use LORAN-C for close in shore navigation extensive calibration and charting efforts would be required. This has not been accomplished and the Coast Guard is not considering undertaking such an immense task, with the exception of a few harbors such as San Francisco. Therefore, it should be recognized that LORAN-C has limitations in the case of close to shore navigation and is not adequate as currently implemented to meet OVTM requirements. There are techniques which reduce the effects of land/sea perturbations and these are discussed below.

By monitoring LORAN-C signals at a fixed site, the received time delay (TD) can be compared with the expected TD based on the known locations of the site. A correction for the area can then be broadcast to users. This technique whereby real-time corrections are applied to LORAN-C TD readings has been demonstrated to provide improved accuracy. This is one method that shows promise of providing the higher precision needed for marine navigation in harbor and harbor entrance areas. Another technique involves installing short baseline, low-power chains to serve specific restricted areas. Such a chain is being evaluated on the St. Marys River in

the Great Lakes. In other locations a low-power transmitter can be added as an additional secondary station to improve the grid geometry and coverage in a local area.

The LORAN-C propagation mode most frequently used for navigation is the ground wave. Sky wave navigation is feasible but with some loss in accuracy. Both ground waves and sky waves may be used for measuring time and time intervals. Although it is designed for use, and normally operated in the hyperbolic mode, LORAN-C can be used to obtain accurate fixes by determining the range to individual stations. This is accomplished by phase comparison of the station signals to a known time reference to determine propagation time, and therefore range from the stations. This is referred to as the range-range (rho-rho) mode. It can be used in situations where the user is within reception range of individual stations, but beyond the hyperbolic coverage area. This method of using LORAN-C requires that the user have a very precise and stable time reference. The high cost of equipment of this type limits the use of this mode.

F.4 VESSEL LORAN-C EQUIPMENT CONSIDERATIONS

Use of the LORAN-C system basically requires a receiver to determine the LORAN-C coordinates of TD numbers (time delay), and charts or tables to convert the LORAN numbers to latitude and longitude position information. There are some receivers which have the capability for direct conversion to latitude and longitude. A LORAN-C receiver which will be useful to the limits of the advertised coverage areas for the U.S. coastal and confluence zone (CCZ) has the following characteristics:

- a. It acquires the LORAN-C signals automatically, without the use of an oscilloscope.
- b. It accomplishes cycle matching on all pulses to take advantage of the maximum accuracy of the system.
- c. It automatically tracks the signals once they have been acquired.

- d. It displays at least two difference readings, with a resolution of at least 0.1 microsecond.

The type of LORAN-C equipment required on-board a vessel depends on what the LORAN-C information output will be used for. If the vessel is to use LORAN-C strictly for position determination then only a basic receiver is necessary. There are many such instruments on the market, with cost of an automatic acquisition and tracking receiver varying from \$2,000 to \$6,000.* Models at the lower end of the cost spectrum in general can receive signals and make TD measurements from one chain, and have little or no flexibility. Those receivers at the higher end have more capability and flexibility - such as automatic selection of the optimum signals for best accuracy. In some receiver systems a limited navigation capability is included.

There are also shipboard LORAN-C and hybrid navigation systems on the market. In general, these systems consist of a LORAN-C receiver with a computer to do data conversion, vessel tracking, and position prediction. The current cost of such systems vary from \$25,000 and up. However it is highly likely that new systems with this capability will be on the market in the near future for less than \$10,000.

If a LORAN-C retransmission system is considered then the vessel equipment required becomes more complex. Not only is a basic receiver necessary, but a means of accessing the receiver data and a device or modem to convert the data into a form suitable for transmission are required. In this type of LORAN-C application, the ship-to-shore communication requirements must be evaluated in terms of range limitations, RF link availability and spectrum crowding and interference.

Only certain receivers are presently configured to provide a remote signal output. In those receivers with this capability there is no standardization in the type of output available. The necessary interface devices to properly convert the receiver output

*An up-to-date listing of LORAN-C receivers on the market is given in the 1977 Wild Goose Radionavigation Journal.

to a form suitable for transmission is available off-the-shelf in only a limited number of receivers. (Teledyne, for instance, markets devices for their 701 and 708 receivers to allow remote monitoring of the receiver by utilizing a mobile radio link.)

F.5 PRESENT USAGE/IMPENDING REQUIREMENTS

In 1974, LORAN-C was designated as the U.S. Government provided system for the CCZ (coastal and confluence zone).¹ Implementation of the program, authorized at that time, is now underway. The coverage of the LORAN-C system based in Alaska, western Canada, and the contiguous 48 states as it now exists is shown in Figure F-1. The coverage planned by 1980 is shown in Figure F-4. The U.S. operated chains of LORAN-A which are being replaced by LORAN-C are scheduled to cease operation on or before December 31, 1980.¹

Since the LORAN-C stations must be land based and they have a useful range of about 1000 NM, it is not feasible to provide a worldwide system utilizing this technique. This coverage is fixed by the area where an adequate signal-to-noise ratio is available; i.e., the system is noise limited.

Overseas there are a number of LORAN-C chains in operation to serve U.S. military requirements for navigational service. Some of the stations are operated by the U.S. Coast Guard, while others are operated by the host country under international agreement. The service is available to all users, military and civilian, of all nations. Other than the United States, however, Canada is the only country that is committed to the operation of LORAN-C service for general use by all navigators. One Canadian station has been built in British Columbia. It will act as master to a combined U.S./Canada chain serving the U.S. northwest, southern Alaska, and West Coast of Canada. In the U.S.S.R. there are two LORAN-C chains operating; one in the southwestern part of Russia, the other in eastern Siberia. Their coverage is mostly over land.

The United States plans no additional development of LORAN-C specifically for use in the high seas environment. The Coast Guard plans to continue its program of expanding LORAN-C service

throughout the CCZ of the contiguous 48 states and southern Alaska, and the Great Lakes. Additional expansion, if any, depends upon future decisions concerning the navigational requirements of Hawaii, northern Alaska, and territories and possessions of the U.S.

The LORAN-C system currently being installed will satisfy most known requirements for the U.S. coastal and confluence zone (CCZ). The RD&D effort to extend the usefulness of LORAN-C to the harbor and harbor entrance will improve the accuracy and stability of the system, thus providing a corollary improvement to service in the CCZ.

Based on a U.S. Coast Guard random sampling survey of 300 vessels in 1975, it has been estimated that 50% of U.S. and 20% of foreign vessels (calling at U.S. ports) greater than 1600 gross tons are presently equipped with LORAN-C receivers. It may also be assumed that almost all new vessels of this size will have sophisticated hybrid navigation systems which include LORAN-C.

The announced intention of the Coast Guard, relative to navigation gear for large tankers entering U.S. waters, is to require use of LORAN-C or a satellite hybrid system of equal accuracy.³

Pertinent to the impending tanker requirement, a Minimum Performance Standard for Marine LORAN-C Receiving Equipment has been drafted by the Radio Technical Commission for Marine Services (RTCM). In the proposed rule for tank vessels,³ the Coast Guard has referred to this RTCM specification as a potential aid to the purchaser of LORAN-C equipment.

F.6 REFERENCES

1. DOT/Coast Guard Local Notice to Mariners, Notice 26, June 30, 1978.
2. National Plan for Navigation, Dept. of Transportation. Report No. DOT-TST-78-4, Nov. 1977.
3. Federal Register, Proposed Rule, Vol. 42, No. 219, November 14, 1977.

APPENDIX G
SHORE-BASED SYSTEM DESIGN CONSIDERATIONS

G.1 FEATURES OF THE IDEAL SYSTEM

Anticipating that practical constraints usually preclude the possibility of achieving an ideal OVTM system, it is still beneficial to state what an ideal system would be. This helps focus attention on the areas where tradeoffs must ultimately be made.

An ideal shore-based OVTM system would have the following features:

- a. It would require no additional equipment beyond the existing radio links, radar, and navigation gear.
- b. It would make minimal demands on the vessel watchstander (VWS)* to communicate by voice, teletype, or other device.
- c. It would provide the vesselmaster with the following services:
 1. Collision alert (a warning that another vessel will pass close by, giving name, course, and speed).
 2. Overtaking alert (enabling coordination of a passing).
 3. Grounding/ramming alert (warning of approach to shoals, aids-to-navigation, oil platform, etc.).
 4. Waypoint ETA adjustment (coordinated arrival at a check point, intersection, traffic lane entrance, etc.).
 5. Emergency communications and services.
 6. Weather, tide, current data; buoy outages or displacements; traffic conditions.
 7. Coordination of pilot acquisition and boarding.

*The vessel watchstander (VWS) performs the onboard duties of communication and logging. The vesselmaster (VM) is responsible for the ship's actions; he may or may not be performing the watchstanding duties.

d. It would provide 24-hour service to 200 nm from the coast.

e. Initial acquisition would be simple, preferably automatic.

f. Shore operators (SO's)* would spend most of their time assessing conflict situations and optimizing traffic flow.

g. Shore stations would be located only at existing Coast Guard facilities.

h. The system would allow evolutionary growth.

i. The shore stations would be simple to operate and maintain.

While even an ideal shore station concept that met all of the above criteria would not eliminate the risk of oil spills in the area of concern, it would provide all the services that are possible from shore. It will be seen that no practical systems meet all the criteria: the systems that provide the most services require complexity of shore station design and on-board equipment.

G.2 SYSTEM DESIGN CONSIDERATIONS

G.2.1 Communication

All shore-based systems require a two-way voice link between ship and shore. Coded systems additionally require the transmission of data, which may or may not be over the voice link. Surveillance systems which require a signal from each ship in order for the shore station to establish ship's position can use the data link transmission for that purpose.

* The term shore operator (SO) is used to denote a Coast Guard officer monitoring offshore traffic. In practice, a division of duties might segregate the watchstanding duties from other operator tasks.

The system range requirement is a key parameter in determining the communications to be used. If system range is only 30 miles or less, the VHF radio telephone frequencies can be used. Ground-wave propagation at MF and HF frequencies can be used beyond 30 miles, and out to 100-200 miles. For ranges of more than 200 miles, buoy relays, high-altitude platforms, or use of sky-wave frequencies would be required. Any system which has an inherent range significantly larger than the system requirement is subject to interference by vessels within the radio range, but beyond the system range (overcoverage).

These problems are specifically addressed in the next sections.

G.2.1.1 Frequency

While only a few frequencies are available in practice for a monitoring or surveillance system, it is helpful to point out some general considerations. There are several possible methods of communication:

- a. Direct communications by line-of-sight propagation.
- b. Direct communications by ground-wave propagation.
- c. Direct communications by sky-wave propagation.
- d. Relayed communications by buoys (ground-wave).
- e. Relayed communications by airplanes (line-of-sight, elevated platform).
- f. Relayed communications by satellite (line-of-sight, elevated platform.).

Ground-wave propagation over the ocean provides reliable communications out to 300 miles for frequencies near 50 MHz, and to 75 miles for frequencies up to 5 MHz. At longer distances and higher frequencies, signal attenuation is higher and sky-wave propagation can cause signal fading. If the shore station is set back several miles, the signal is further weakened by conductive losses in the earth.

Sky-wave propagation is the dominant mechanism in communication from 5 to 25 MHz beyond 100 miles. In this transmission mode, radio waves are reflected back down to earth from ionospheric layers which provide a sharp dielectric gradient to the transmitted wave. Unfortunately the layers vary in location and strength diurnally, seasonally, and with sunspot activity. A communications link in this frequency band would be subject to frequent loss of contact with ships beyond 100 miles range. Fades resulting from out-of-phase interference between ground-waves and sky-waves would cause loss of contact closer in for higher frequencies. In addition, interference from ship and non-ship transmitters several hundred miles away would be problematical.

Line-of-sight propagation considerations apply to frequencies above 30 MHz, although sky-wave signals are occasionally experienced at these frequencies as well. Reflections from the ocean can occasionally result in severe fading under smooth sea conditions; this effect is most noticeable at short ranges (less than 5 miles) and high frequencies (greater than 3 GHz). At frequencies above 10 GHz, horizon communication is often lost due to attenuation by rain; X-band radars (9.4 GHz) suffer reduced range due to heavy rainfall. High altitude platform relays could be used to 150 miles (blimps), or even out to 500 miles (high-altitude aircraft), with similar rainfall limitations. Satellite communication, on the other hand, can be attained up to 15 GHz, since the vertical thickness of the attenuating medium is small, typically less than 2 miles; even with satellites, attenuation by rain can cause signal dropout at low elevation angles.

In order to provide vessels with emergency and traffic control services, it is necessary to have a continuous shore/ship communication link to the bridge of each participating vessel; interruptions (e.g., by fades) of more than a few seconds would not be tolerable. Therefore, the frequency band from about 4-20 MHz would not be adequate. Likewise the use of communication by meteor trails (Sites, 1977) would not be adequate for this purpose.

For obtaining initial information about the ship, this limitation does not apply, because the information is not time-critical.

G.2.1.2 Use of Existing Coast Guard Radio Systems

The maritime mobile radio telegraph segment, from 415 to 490 kHz, is used for distress alert, AMVER messages, and meteorological messages from merchant ships by CW. It is possible that this frequency could be used to transmit initial ship data, since the data are similar in content to the AMVER data. However, it is unlikely to be available as a voice link, or for coded data transmissions.

The LORAN-A system is presently being phased out in favor of the more reliable LORAN-C system, which operates at 100 kHz. LORAN-A frequencies occupy the band 1800-2000 kHz, which is excellent for achieving range of 100-200 miles from the coast. Half of the band (1800-1900 kHz) has been promised as an amateur radio band. The decommissioned facilities (particularly the antennas) could be used for communications which require much less maintenance than the former navigation stations. (See Table G-1.)

There are several maritime mobile radio telephone segments in the 2-4 MHz band, including the 2.182 MHz international distress and calling frequency (see Table G-2). Many vessels have used AM radios in this band for short range communication, but these are being phased out in favor of SSB equipments. The band is considered reliable out to 75 miles, and usually exhibits a larger range. There is competition for this frequency band: the commercial Coastal Harbor Radiotelephone Service operates ship interconnections to the public telephone system; the Coast Guard uses it for communication; and meteorological broadcasts are made in this band. In spite of the competition, this band can be considered for the purpose of ship/shore voice and data communications.

Long range radio telegraph communications via sky-wave propagation is obtained for Coast Guard and merchant ships at 4,6,8,

TABLE G-1. LORAN-A STATIONS

Nantucket, MA
Sandy Hook, NJ
Cape Hatteras, NC
Folly Beach, SC
Jupiter, FL
Venice, FL
San Blas, FL
Grand Isle, LA
Galveston, TX
Port Isabel, TX
San Mateo, CA
Point Arguello, CA
Point Arena, CA
Cape Blanco, OR
Point Grenville, WA
Biorka, AK
Ocean Cape, AK
Spruce Cape, AK
Atta, AK
Adak, AK
Cape Sarichef, AK
San Juan, PR

TABLE G-2. VHF AND 2182 kHz STATIONS

Location	Station Identification	VHF Ch 16	kHz 2182
<u>State of MAINE</u>			
Quoddy Head	Jonesport Station	X	X
Jonesport	Jonesport Station	X	X
Mt. Cadillac	Group Southwest Harbor	X	
Bass Harbor	Group Southwest Harbor		X
Owls Head	Rockland Station	X	X
Rockland	Rockland Station	X	X
Brunswick	Group Portland	X	
Mt. Independence	Group Portland	X	
Cape Elizabeth	Group Portland		X
Mt. Agamenticus (York)	Group Portland	X	
<u>State of VERMONT</u>			
Mt. Mansfield	Burlington Light Station	X	
<u>State of MASSACHUSETTS</u>			
Newburyport	Merrimac River Station	X	X
Gloucester	Gloucester Station	X	X
Eastern Point	Gloucester Station	X	X
Boston	Group Boston	X	
Pt. Allerton	Pt. Allerton Station	X	X
Scituate	Scituate Station	X	X
Race Point	Race Point Station	X	X
Pilgrim Monument (Provincetown)	Race Point Station	X	
Cape Cod Canal	Cape Cod Canal Station	X	X
Chatham	Chatham Station	X	X
Nobska Point	Group Woods Hole	X	X
Menemsha	Menemsha Station	X	X
Nantucket	Brant Point Station	X	
Brant Point	Brant Point Station	X	X
<u>State of RHODE ISLAND</u>			
Jamestown Bridge	Castle Hill Station	X	
Castle Hill	Castle Hill Station	X	X
Point Judith	Point Judith Station	X	X
Block Island	Block Island Station	X	X
<u>State of CONNECTICUT</u>			
Connecticut River Waterford (Millstone Pt.)	Group Long Island Sound	X	
New Haven	Group Long Island Sound	X	X
Fishers Island	Group Long Island Sound		X
Millford	Group Long Island Sound	X	

TABLE G-2. VHF AND 2182 kHz STATIONS (Cont.)

Location	Station Identification	VHF Ch 16	kHz 2182
<u>State of NEW YORK</u>			
Eatons Neck	Group Long Island Sound	X	X
Montauk	Group Shinnecock	X	X
Shinnecock	Group Shinnecock	X	X
Moriches	Group Shinnecock	X	
Fire Island	Group Rockaway	X	
New York City	Group New York	X	
Mt. Beacon (Hudson R.)	Group New York	X	
Saugerties (Hudson R.)	Saugerties Sta. or		
	Group New York	X	
<u>State of NEW JERSEY</u>			
Sandy Hook	Group Sandy Hook	X	X
Manasquan	Group Sandy Hook	X	
Barnegat	Group Atlantic City	X	
Atlantic City	Group Atlantic City	X	X
Cape May	Group Cape May	X	X
Fortescue	Group Cape May	X	
Dela. Memorial Bridge	Base Gloucester	X	
Burlington Bristol Br.	Base Gloucester	X	
<u>State of DELAWARE</u>			
Dela. Memorial Bridge	(See "New Jersey")		
Rehoboth Beach	Group Cape May	X	X
<u>State of MARYLAND</u>			
North East	Group Baltimore	X	
Catonsville	Group Baltimore	X	
Annapolis	Group Baltimore	X	X
Crisfield	Group Chincoteague	X	X
Ocean City	Group Chincoteague	X	X
<u>State of VIRGINIA</u>			
Alexandria	Group Baltimore	X	
Oak Grove	Group Baltimore	X	
Chincoteague	Group Chincoteague	X	X
Parramore Beach	Group Chincoteague	X	X
Cobbs Creek	Group Hampton Roads	X	
Newport News	Group Hampton Roads	X	
Portsmouth	Group Hampton Roads	X	
Cape Henry	Group Hampton Roads	X	X
Pungo	Group Hampton Roads		X

TABLE G-2. VHF AND 2182 kHz STATIONS (Cont.)

Location	Station Identification	VHF Ch 16	kHz 2182
<u>State of NORTH CAROLINA</u>			
Elizabeth City	Eliz. City Air Station	X	
Edenton-Midway	Eliz. City Air Station	X	
Oregon Inlet	Group Cape Hatteras	X	X
Englehard	Group Cape Hatteras	X	X
Cape Hatteras (Buxton)	Group Cape Hatteras	X	X
Hatteras Inlet	Group Cape Hatteras		X
Hobucken	Group Fort Macon	X	X
Cedar Island (Lola)	Group Fort Macon	X	
Croatan National Forest	Group Fort Macon	X	
Holly Ridge	Group Fort Macon	X	
Carolina Beach	Group Fort Macon	X	X
<u>State of SOUTH CAROLINA</u>			
Myrtle Beach	Group Charleston	X	
Mt. Pleasant	Group Charleston	X	
Sullivans Island	Group Charleston		X
Parris Island	Group Charleston	X	
<u>State of GEORGIA</u>			
Tybee Island	Group Charleston		X
St. Simons Island	Group Mayport		X
Jekyll Island	Group Mayport	X	
<u>State of FLORIDA</u>			
Mayport	Group Mayport		X
Jacksonville Beach	Group Mayport	X	
Jacksonville Beach	Group Mayport		X
Flagler Beach	Group Mayport	X	
Cape Kennedy	Group Mayport	X	
Cape Kennedy	Group Mayport		X
Fort Pierce	Fort Pierce Station	X	
Fort Pierce	Fort Pierce Station		X
Jupiter	Group Miami	X	
Lake Worth	Group Miami		X
Delray Beach	Group Miami	X	
Fort Lauderdale	Group Miami		X
Miami Beach	Group Miami		X
Princeton	Group Miami	X	
Card Sound	Group Miami		X
Islamorada	Group Key West	X	
Islamorada	Group Key West		X
Marathom	Group Key West	X	X

TABLE G-2. VHF AND 2182 kHz STATIONS (Cont.)

Location	Station Identification	VHF Ch 16	kHz 2182
<u>State of FLORIDA (Cont.)</u>			
Key West	Group Key West	X	X
Naples	Group St. Petersburg	X	
Fort Myers	Group St. Petersburg		X
Venice	Group St. Petersburg	X	
Mullet Key	Group St. Petersburg		X
Seminole	Group St. Petersburg	X	
Clearwater	Group St. Petersburg		X
Tarpon Springs	Group St. Petersburg	X	
Crystal River	Group St. Petersburg	X	
Yankeetown	Group St. Petersburg		X
Steinhatchee	Group St. Petersburg	X	
St. Marks	Group Mobile	X	
Cape San Blas	Group Mobile	X	
Panama City	Group Mobile	X	X
Fort Walton	Group Mobile	X	
<u>State of ALABAMA</u>			
Spanish Fort	Group Mobile	X	X
<u>State of MISSISSIPPI</u>			
Gulfport (See Western Rivers Section, Mississippi River)	Group Mobile	X	
<u>State of LOUISIANA</u>			
Venice	Group New Orleans	X	
Chalmette	Group New Orleans	X	
Leeville	Group Grand Isle	X	
Southbend	Group Grand Isle	X	
Pecan Island	Sabine Station	X	
Cameron	Sabine Station	X	
<u>State of TEXAS</u>			
Sabine	Sabine Station	X	X
Morgan Point	Group Galveston	X	X
Houston	Houston Station	X	X
Galveston	Group Galveston	X	
Freeport	Group Galveston	X	X
Port O'Connor	Group Port Aransas	X	X
Robstown	Group Port Aransas	X	
Port Mansfield	Group Port Isabel	X	
Port Isabel	Group Port Isabel	X	

TABLE G-2. VHF AND 2182 kHz STATIONS (Cont.)

Location	Station Identification	VHF Ch 16	kHz 2182
<u>State of CALIFORNIA</u>			
Point Loma	Group San Diego	X	
San Clemente Island	Group San Diego		X
San Clemente Island	Long Beach Radio Station	X	
San Pedro Hill	Long Beach Radio Station	X	
Point Vicente	Long Beach Radio Station		X
Laguna Peak	Channel Island Harbor Sta.	X	
Oxnard	Channel Island Harbor Sta.		X
Pt. Conception	Channel Island Harbor Sta.		X
Tranquillon Mt.	Channel Island Harbor Sta.	X	
Cambria	Group Monterey	X	X
Point Sur	Group Monterey	X	X
Point Pinos	Group Monterey		X
Mt. Umunhum	Group Monterey	X	
Mt. Diablo	Group San Francisco	X	
Bethel Island	Group San Francisco		X
Hamilton AFB	Group San Francisco		X
Point Reyes	San Francisco Comm. Sta.		X
Rio Vista (Sacramento R.)	Rio Vista Station	X	X
Jenner (Seaview)	Group San Francisco	X	
Point Arena	Group Humboldt Bay		X
Cahto Peak	Group Humboldt Bay	X	
Samoa	Group Humboldt Bay		X
Trinidad Head	Group Humboldt Bay	X	
Point St. George	Group Humboldt Bay		X
Lake Tahoe*	Lake Tahoe Station	X	
<u>State of OREGON</u>			
Cape Sebastian	Group Coos Bay	X	
Port Orford	Group Coos Bay	X	X
Seven Devils	Group Coos Bay	X	
Heceta Head	Group Coos Bay	X	
Yaquina Head	Group Coos Bay	X	
Cape Meares	Group Astoria	X	
Portland (Sky Line)	Group Portland	X	
Rainier	Group Portland	X	
<u>State of WASHINGTON</u>			
Jump Off Joe Mt.	Kenniwick Station	X	
Cape Disappointment	Group Astoria	X	
Grays Harbor	Group Astoria	X	X
Kalaloch	Group Port Angeles	X	

* Seasonal

TABLE G-2. VHF AND 2182 kHz STATIONS (Cont.)

Location	Station Identification	VHF Ch 16	kHz 2182
<u>State of WASHINGTON (Cont.)</u>			
Bahokus Peak	Group Port Angeles	X	X
Port Angeles	Group Port Angeles		X
Gold Mountain	Group Seattle	X	
King-TV Tower	Group Seattle	X	
Mt. Constitution	Group Seattle	X	
<u>State of ALASKA</u>			
Ketchikan	Ketchikan Radio Station	X	X
Five Finger	Five Finger Station		X
Lean Point	Juneau RCC		X
Juneau	Juneau RCC	X	X
Biorka Island	Biorka Is. Station		X
Cape Spencer	Juneau RCC		X
Ocean Cape	Ocean Cape Station		X
Middleton Island	Kodiak Communication Sta.		X
Site Summit	Kodiak Air Sta.	X	
Kodiak	Kodiak Communication Sta.		X
Pillar Mountain	Kodiak Air Station	X	
Sitkinak	Sitkinak Station		X
Cape Sarichef	Cape Sarichef Sta.		X
Port Clarence	Port Clarence Sta.		X
Saint Paul Island	St. Paul Island Sta.		X
Adak	Adak Island Station		X
Attu	Attu Island Station		X
<u>State of HAWAII and PACIFIC</u>			
Upolu Point, Hawaii,	Hi. Upolu Point Station		X
Mt. Haleakala, Maui,	Hi. Honolulu Radio Station	X	
Mt. Kaala, Oahu, Hi.	Honolulu Radio Station	X	
Kauai, Hi.	Kauai Station		X
French Frigate (Tern Isl.)	French Frigate Sta.		X
Finigayen, Guam	Guam Radio Station		X
Orote Point, Guam	Guam Radio Station	X	
<u>Area of PUERTO RICO</u>			
San Juan	Base San Juan	X	
El Yunque	Base San Juan	X	
Cerro De Punta	Base San Juan	X	
Monte del Estado	Base San Juan	X	
Crown Mountain,			
St. Thomas, V.I.	Base San Juan		X
Signal Hill,			
St. Thomas, V.I.	Base San Juan	X	

12, 16, and 22 MHz. Fax and teletype data are now transmitted, and could be used for initial communication of ship data. While radio-telephone and radiotelegraph channels are also identified in the 4-25 MHz band, problems of overcoverage and coverage gaps make this band appear unattractive for voice and data communications in a monitoring and surveillance system.

VHF (156-162 MHz) could be used for short range ship-shore communication, e.g., out to 20-40 miles from the station. Channels 11, 12, 13 and 14 are now used in VTS's for ship/shore communications. While there would be problems with overlapping VTS/OVTM channel usage, it is worth consideration for some areas -- most vessels have these radios now (see Table G-2).

G.2.1.3 Voice/Data Multiplexing

If data were transmitted over the same channel as voice, it could occupy one of three audio bands within the channel: sub-audible (0-300 Hz), audible (300-3000 Hz), or superaudible (3000-10,000 Hz). Subaudible data multiplexing is limited to low data rates, namely 100 BAUD. Audible data multiplexing would result in "beeps" being heard each time a data transmission from a neighboring ship or shore station occurs - this is potentially irritating. Superaudible data multiplexing is technologically feasible now, due to the availability of inexpensive crystals which have good frequency stability. Up to now the frequency drift of receivers limited the useful bandwidth of a 25 kHz channel to about 12 kHz (double sideband AM). This capability should be considered in any system design requiring data transmission.

G.2.1.4 Satellites

Satellite communication is finding wider application and increased usage in the civilian sector. Costs per message are decreasing every year, and reliability is high; availability is continuous. Satellite terminals can be leased as well as purchased, so that the capital investment of a shipping company need not be

high during a trial period. While this alternative has the initial appearance of an "overkill" approach, the fact that it has application in other areas of the maritime industry, and for other Coast Guard missions, renders it worthy of further consideration.

Satellite communication can be used by equipped vessels to transmit initial ship data from out at sea, i.e., beyond line-of-sight communications. The expense of the equipment is still too high for use by smaller vessels, so that satellite communication cannot be chosen as the exclusive means of communication for any function.

G.2.1.5 Problems of Overcoverage

If the communications range significantly exceeds the system range requirement, transmissions by vessels (or by ground stations, vehicles, or aircraft) can cause interference in several ways:

- a. The unwanted transmissions may obscure or overpower transmissions from ships within the coverage zone.
- b. Delays in voice communication may result from non-availability of the channel.
- c. Shore personnel and computer efforts required to distinguish between desired and undesired messages may prove bothersome.

Of course, if the channel is dedicated to ship/shore voice and data communication, this problem can be controlled: ship reports would only be transmitted where required, roll-call systems would only interrogate vessels in the coverage zone, etc. The problem would be most serious in the case where the channel was shared with other maritime or with land based or aircraft functions. Satellites have a scheduling problem which is solved by frequency and time multiplexing techniques.

G.2.2 System Range

The system range requirement depends on the results of the casualty analysis: where do casualties occur, and what is the

casualty type? If all casualties occur within 50 miles of the coast, there is little need to have 200 miles of coverage. The casualty analysis of Section 4.4 shows that all groundings except three occurred within 20 miles of the shore. One of these three was the Argo Merchant (27 miles from Nantucket); the other two involved "lumps" in fairways - accumulations of sand in the Gulf of Mexico. Of 17 collisions, 13 were within 20 miles of shore. However, only one of the 6 rammings took place within 20 miles. Only one casualty, a collision, occurred further out than 100 miles (108 miles). All oil platforms are within 100 miles of shore.

Thus, most accidents occur within VHF range of shore stations (20-40 miles). Furthermore, there is little justification for providing the services in Section G.1 beyond 100 miles; thus MF frequencies are quite adequate for OVTM stations, if service beyond VHF range is desired. Systems which provide coverage beyond 100 miles cannot be justified solely for the purpose of providing OVTM services.

It is a truism, but worth stating, that there is no point in requiring the shore station to accurately know vessel position beyond the range of immediate communications. That is, even if the shore station knew of a potential collision at 100 miles, it would be useless if communication with the bridge were only available to 20 miles.

G.2.3 System Capacity/Data Update Rate

System capacity is like the strength of a chain: it is constrained by its weakest link. There are several factors, any of which may limit the capacity:

- a. The number of shore operators.
- b. The number of vessels each operator can readily manage.
- c. The memory capacity of the shore-based computer, if one is used.
- d. The communication channel capacity.

e. The average channel communication time required per voyage for each vessel.

The degree of system automation affects the shore operator's efficiency and the communication time. It is the key variable in determining the capacity of the system.

It will be assumed in this analysis that it will always be possible to hire enough operators, purchase enough computer memory, and sectorize the coverage zone into small enough areas that a. through c. will not ultimately limit the system capacity. The following cautions should be noted, however:

a. If too many sectors are required, SO's will spend an undue amount of time in handoff procedures, distracting them from their primary traffic control duties.

b. If too much time is spent in bookkeeping duties (i.e., obtaining ship's positions and course data, keying in data, writing data on logs, advancing plotting board targets, etc.) the SO's effectiveness will be reduced.

In VTS stations at Houston, San Francisco, and Puget Sound, the capacity per operator is 20-30 vessels, with the higher figure able to be sustained for limited periods of time. As a rule of thumb for all-verbal type systems, about $N/20$ operators would be required to man a station whose coverage incorporated N vessels on the average. Thus if a station were expected to have 200 vessels at a time within its coverage, about 10 operators would be required. Of course, as more SO duties are automated, each SO can handle more traffic comfortably.

Complications stemming from the fact that all SO's may be using the same channel, and from the fact that adjacent shore stations will have overlapping coverage areas, must be considered in the final assessment of system capacity. For the purposes of this discussion, these complications will be ignored.

The capacity of a communications channel depends on the average message length per vessel, the number of minutes between position reports (update period), and the utilization factor. The

utilization factor is the acceptable fraction of time that a given channel can be in use before users begin to encounter excessive waiting time. In a study for the New York VTS, Armacost (1977) developed a useful model for the purpose of assessing this problem. He showed that for that system, a utilization factor of 0.50 resulted in an expected waiting time of 17 seconds, while a factor of 0.66 resulted in a 33-second waiting time. Waiting times of more than 15 seconds will be irritating to vessel watchstanders, so that utilization factors higher than 0.5 are to be avoided. Message length for position and course reporting is expected to be 20-30 seconds, about the same as for VTS's (a study for the San Francisco VTS indicated 27 seconds as an average message length (Brown, et al, 1973)).

Figure G-1 shows a plot of capacity versus update rate for a message time budget of 50% for bookkeeping (position, course) and 50% for advisories from shore. It shows that verbal systems in general have severe capacity limitations, if updates are needed more than hourly. Also, specific advisories to vessels are limited in heavy traffic. It shows as well that ship data, which could take 1-3 minutes to report verbally, should not be sent on the same channel.

G.2.4 Initial Check in to the System

Vessels planning to enter a U.S. port from abroad are required to notify the Captain of the Port at least 24 hours in advance of arrival. Since this information can be sent by an agent several days in advance, it is not useful as a check in to a traffic system.

Neither is it acceptable for tanker and other vessels to wait until they are within VHF range, partly because of the channel congestion problem that would be caused by the glut of ship information, but also because of the fact that this allows insufficient time to review the ship information contained in the Marine Safety Information System (MSIS). Therefore tank vessels and hazardous cargo vessels, in particular, should be required to provide ship information at an initial check in beyond VHF range. The present

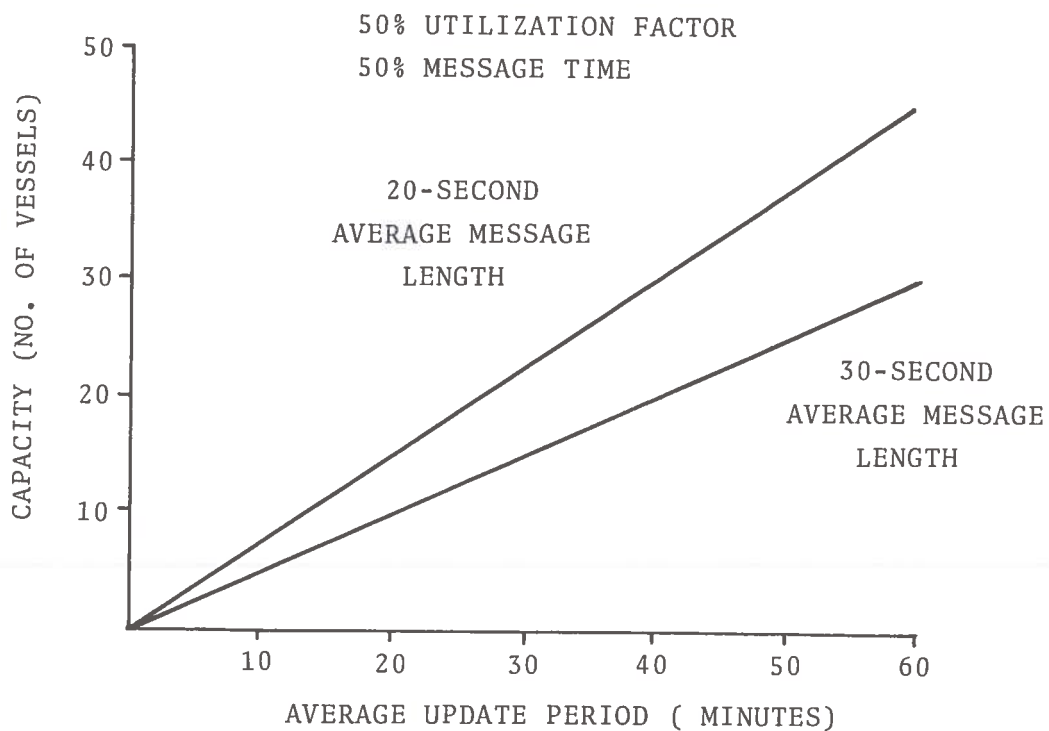

FIGURE G-1. COMMUNICATION CHANNEL CAPACITY AS A FUNCTION OF UPDATE RATE

24 hours requirement can simultaneously be satisfied by a report via present radio telegraph or teletype services at 24 hours out. The information should include the nine items required by the MSIS: Name, flag, call sign, official number, propulsion, length, gross tonnage, net tonnage, and horsepower. In addition it should include the master's name, owner's or lessee's name, draft, cargo, ship type, and destination. Finally, it should include the present position, ETA at the destination port, a list of waypoints (if appropriate), and a statement either stating that all navigation and control gear are working, or a list of deficiencies. A form such as that shown in Figure G-2a should be printed and made widely available to shipping companies to speed up the transmissions.

If the system design calls for vessels other than tank vessels to check in, a reduced list can be used for them. Departing vessels (loaded) should also file a 24-hour notice. Tank barges should be incorporated into the system--even a 2000 gross ton barge can cause a massive oil spill if all the cargo escapes.

Initial check in from sea could also be transmitted by satellite or any AMVER circuit, if other means were unavailable.

G.2.5 Verbal Vs Coded Ship Data-Equipment Implications

Ship's data can be communicated to the shore station in several ways: by the VWS's verbal message, by a teletyped message, or by an automatic data transmission. (See Figure G-2b.)

Voice transmission is now used at VTS stations at Seattle, Valdez, San Francisco, Houston, and New Orleans, and has the advantages of familiarity and human contact. The disadvantage, of course, is that voice is a relatively inefficient means of communicating data: what takes a watchstander 30 seconds to describe can be reliably relayed in a fraction of a second by code.

Teletyped messages that are required more often than hourly are a nuisance, particularly if the teletype (or telegraph) is located off the bridge or wheelhouse. The radio officer may not be on his watch, which means that the watchstander must frequently perform the duty. This has totally undesirable complications.

SHIP'S NAME (SNM): _____

VESSEL MASTER (VM): _____

SHIP TYPE (TP): TKR BLK LNG LPG CONT FRT

CARGO (CG): _____

CARGO WEIGHT (CGW): _____ (TONS)

SHIP CAPACITY (DWT): _____ (TONS)

SHIP DRAFT (DR): _____ (FEET)

CALL SIGN (CS): _____

VHF CODE (VHF): _____

DESTINATION (DST): _____

ETA AT DESTINATION (ETA): _____

CHART OF LARGEST SCALE (CH): _____

DEFICIENCIES (DEF): LORAN-C or Satellite Navigation (LOR): _____

X-Band Radar (XRA): _____

S-Band Radar (SRA): _____

Collision Avoidance Aid (CAA): _____

Fathometer (FTH): _____

Chart Recorder (CHR): _____

Gyro Compass (GYC): _____

Magnetic Compass (MGC): _____

VHF Comm. (VHF): _____

HF Transmitter (HFT): _____

HF Receiver (HFR): _____

Teletype (TT): _____

Radiotelegraph (CW): _____

Steering Malfunction (ST): _____

Propulsion Problem (PP): _____

FIGURE G-2a. POSSIBLE CHECK LIST

NM-GULFSTAR; VM-SMITH; CS-WXYZ; VHF-WEX5421;
 CG-2 OIL; CGW-65000; TP-TKR; DWT-70000; DR-35;
 DST-NYC; CH-12326; ETA-1430; DEF-SRA, CHR.

FIGURE G-2b. SAMPLE TRANSMISSION

The data could be sent manually, using an encoder module as shown in Figure G-3. At each maneuver or waypoint, the watchstander would reset the thumb wheels and push the transmit button. An acknowledgement by the shore station would light up the "acknowledge" lamp. Even this is time-consuming, and is not that much cheaper than an automatic encoder module.

The most desirable, as well as the most expensive, shipboard equipment would read time delays from the LORAN-C unit, speed from the ship's log, and heading from the ship's gyro, and arrange the data in the proper format for transmission. The transmission could then be keyed by a shore request, a manual command, or a clock pulse (see Figure G-4). This has the marked advantage of requiring no action on the part of the vessel watchstander. At the shore station, no keying operations would be required. The SO could then devote most of his time to conflict assessment and traffic flow.

It is therefore concluded that if coded transmissions are used to report ship's course and speed, it should be done automatically.

G.2.6 Roll-Call Versus Ship-Initiated Transmissions

There are two distinct methods of collecting information from the vessels: one is the roll-call method, in which vessels are interrogated one by one by a shore station and respond when addressed; the second depends on each vessel to send data to shore, either at regular intervals, or at agreed-upon way points (check-points, intersections, points of planned course alterations, or at regular points along a course).

These two methods apply to both monitoring and surveillance-type systems. Roll-call systems have the following advantages:

a. The data update rate is controlled from shore, and can be varied for each vessel to account for variations in traffic density, number of course alterations, and vessel speed. This increases system capacity, and provides flexibility for emergencies.

b. The system saturates in a "soft" manner: as the number of vessels begins to exceed a threshold value, the update rate can be reduced by a small percentage to accommodate the new vessels.

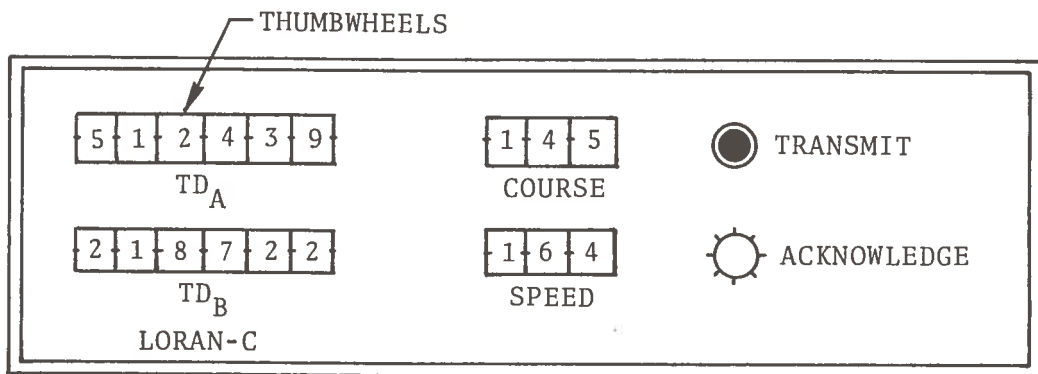

FIGURE G-3. DATA TRANSMISSION ENCODER MODULE - MANUAL

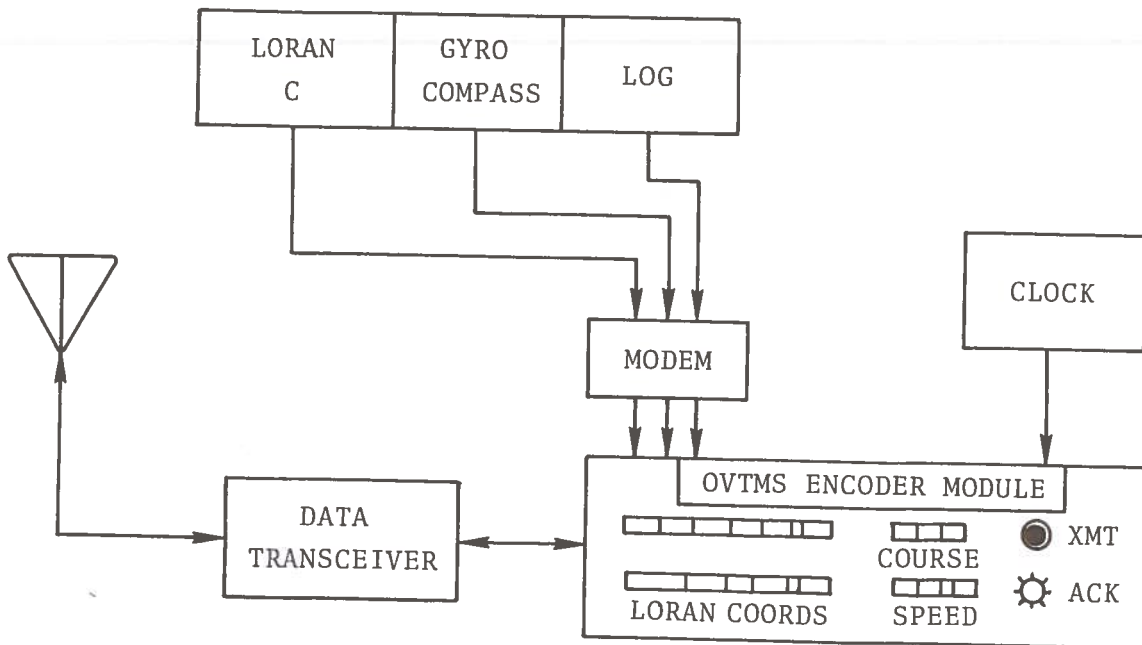

FIGURE G-4. DATA TRANSMISSION ENCODER MODULE - AUTOMATIC

Roll-call systems do have the disadvantage of being somewhat more expensive.

Ship-initiated transmission systems have their own peculiar advantages:

a. For voice-reporting system, VWS's can work the transmission into their work schedules with more ease, rather than drop their immediate task to reply to the shore-master.

b. For voice-reporting systems, the transmissions are more geared to significant events: waypoints reached, course changes, etc.

c. Entry into the system is performed in much the same way as updating course data.

Similarly, there are disadvantages as well to ship-initiated systems:

a. If two ship transmissions overlap, the shore will get, at most, one ship's data--thus this type system is more likely to experience interference.

b. In voice-reporting systems, VWS's are more likely to forget to communicate course changes, waypoints reached, etc.

It is therefore concluded that voice-reporting systems should be ship initiated, and coded data systems should be controlled from shore.

G.3 SYSTEM CONCEPTS

G.3.1 Check In Systems

Check in systems (see the Vessel Passport System, Sections 5.2.2 and 7.2) make no attempt to monitor the point-by-point progress of any vessel, but rather rely on weeding out carelessly equipped or managed vessels, providing special assistance to deficient vessels, and providing cross-checking and redundancy of function to ensure the accuracy and correctness of onboard navigation gear. At initial check in, equipment is turned on and checked for operational status (see Figure G-5).

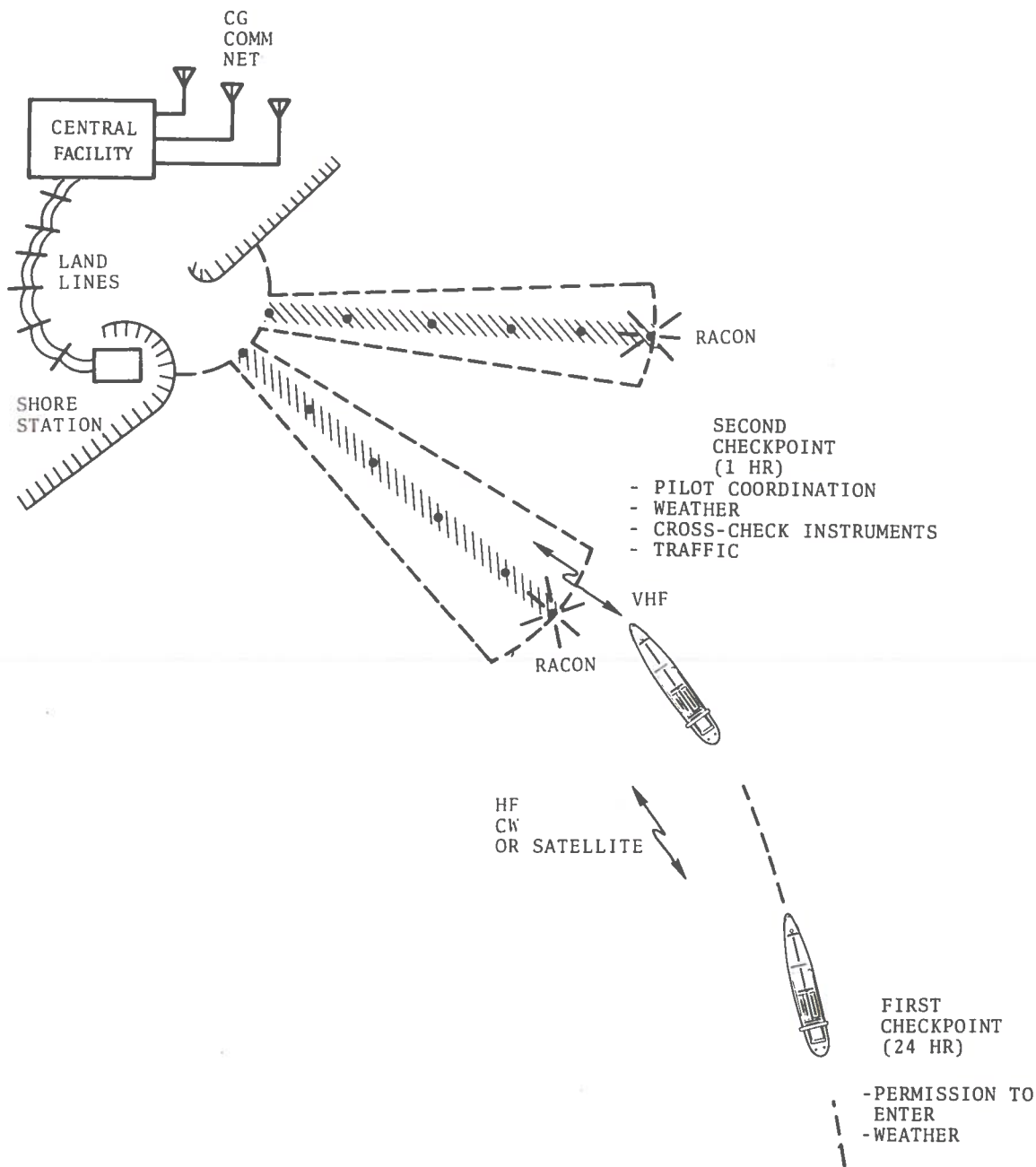

FIGURE G-5. VESSEL PASSPORT SYSTEM

A second check in about an hour out from the internal waters provides a mandatory check on navigation gear against a known reference. Weather, tide, current and buoy information is provided at this time.

The total amount of time required is about 2-5 minutes at the initial check in, and 1-3 minutes at the second check in. This service could be provided to all tankers, and to others upon request.

This system would not provide the collision prevention service directly. Strayings from traffic lanes (e.g., to avoid a collision) would likewise not be detected. Poorly equipped vessels would be detected, however, and careless navigational errors would be avoided. Table G-3 shows a list of suggested RACON locations. Table G-4 is a list of possible vessel passport stations.

G.3.2 Monitoring Systems

Monitoring systems can be ship-initiated or roll-call; they can use verbal or coded interrogations; or they can use verbal or coded replies. However, from the discussions of Section G.2, there are only two which are viable: ship-initiated verbal position reporting, and automatic roll-call coded position reporting. In all cases a voyage plan, either submitted in advance, or at the time of entry to the system, is assumed. The voyage plan would contain vessel information and the planned route (refer to Figure G-2).

G.3.2.1 Ship-initiated Waypoint Reporting--Verbal

In this system, the vessel watchstander calls the shore station when a course maneuver is being initiated, when an agreed upon waypoint is reached, or when the voyage plan is altered. The initiative is left primarily with the vessel master; however, if no report has been received within a short time after a scheduled waypoint should have been reached, the shore operator will initiate the call.

TABLE G-3. SUGGESTED RACON LOCATIONS

Location	Identifying Feature	Latitude	Longitude
<u>(Atlantic)</u>			
Portland	Exists		
Boston-Mass. Bay	R" B"	42 ⁰ -22.5'	70 ⁰ -47'
Cape Cod	BW "BD"	42 ⁰ -8'	69 ⁰ -53'
Great South Channel	PA	40 ⁰ -48'	69 ⁰ -0'
Nantucket	Lightship	40 ⁰ -30'	69 ⁰ -30'
Rhode Island Sound	BW "A"	41 ⁰ -7'	71 ⁰ -24'
Long Island Sound	Plum Island	41 ⁰ -11'	72 ⁰ -13'
New York	Ambrose Light	40 ⁰ -78'	73 ⁰ -50'
Delaware Bay	R "F"	38 ⁰ -47'	74 ⁰ -34.5'
Delaware Bay	R "D"	38 ⁰ -27'	74 ⁰ -42'
Chesapeake Bay	RB "CBJ"	36 ⁰ -56'	75 ⁰ -57.5'
Cape Hatteras	Diamond	35 ⁰ -9'	75 ⁰ -18'
North Miami Beach (Gulf of Mexico)	Outfall	25 ⁰ -54'	80 ⁰ -7'
Ft. Jefferson Nat. Mon.	Loggerhead Key	24 ⁰ -38'	82 ⁰ -55'
Tampa Bay	Egmont Key	27 ⁰ -36'	82 ⁰ -46'
South of Mobile Point	Platform	29 ⁰ -27'	87 ⁰ -49'
Breton Sound	Exists		
Southwest Pass, Mississippi	Exists		

TABLE G-3. SUGGESTED RACON LOCATIONS (Cont.)

Location	Identifying Feature	Latitude	Longitude
East of East Flower Garden Bank	Platform	28 ⁰ -7'	92 ⁰ -50'
South of Calcasieu Pass	Platform	28 ⁰ -40'	93 ⁰ -13'
Calcasieu Pass	BW "CC"	29 ⁰ -27'	93 ⁰ -13'
Sabine Lake	R "4"	29 ⁰ -29'	93 ⁰ -40'
Galveston Bay	R "2"	29 ⁰ -5'	94 ⁰ -14'
South of Galveston	Platform	28 ⁰ -5'	94 ⁰ -27'
Aransas Pass	New Buoy	27 ⁰ -41.5'	96 ⁰ -47.5'
Port Isabel (Puerto-Rico)	New Buoy	26 ⁰ -4'	96 ⁰ -57'
Puerto Rico (South)	Guayanilla/ Tallaboa Bay	Erect Land Station on Punta Guayanilla	
Puerto Rico (North)	San Juan	18 ⁰ -28.5'	66 ⁰ -7'
<u>(Pacific)</u>			
San Diego	Point Loma	32 ⁰ -40'	117 ⁰ -15'
Los Angeles	Catalina Island	33 ⁰ -21'	118 ⁰ -20'
Santa Barbara Channel	Anacara Island	34 ⁰ -1'	119 ⁰ -22'
San Francisco	R "SF" - Exists		
Cape Mendocino	R "B"	40 ⁰ -26'	124 ⁰ -30'
Cape Blanco		42 ⁰ -50'	124 ⁰ -34'
Cape Disappointment	Lightship Columbia	46 ⁰ -11'	124 ⁰ -11'
Strait of Juan De Fuca	2 Exist		

TABLE G-4. POSSIBLE VESSEL PASSPORT STATIONS

- | |
|--------------------------------------|
| 1. Portland |
| 2. Boston |
| 3. New York City* |
| 4. Delaware Bay Entrance |
| 5. Chesapeake Bay Entrance |
| 6. Miami |
| 7. Tampa/St. Petersburg |
| 8. New Orleans* |
| 9. Houston/Galveston* |
| 10. Los Angeles/Santa Barbara |
| 11. San Francisco* |
| 12. Puget Sound* |
| 13. Valdez* |
| 14. San Juan |
| 15. Guayanilla/Tallaboa Bay Entrance |

* VTS locations.

In this system the procedure for acquiring new information and assessing the situation would typically consist of the following steps (approximate times, in seconds, are included parenthetically):

- a. VWS calls the shore station (3)
- b. SO acknowledges call (5)
- c. VWS reports t_A , t_B (LORAN-C coordinates), course, speed, and ETA at the next waypoint (20)
- d. (Optional) SO reports data back, receives acknowledgement (20)
- e. SO keys in data (15)
- f. Computer compares data with projections (5)
- g. Computer updates display (5)
- h. SO reassesses conflict situation (7)

The total time involved for this exchange is typically 70-90 seconds, depending on whether the verification step (4) is included. In VTS systems, this is not normally performed, unless there is an uncertainty on the part of the SO.

The shipboard equipment needed to function in the system consists of a LORAN-C receiver (or equivalent), ship's log, compass, and communications gear (see Figure G-6). All of these will normally be on-board, but the communications gear may be new. The ship's navigator has to use his skill to correct the heading information to estimate his ship's track, or course over ground. In high winds and heavy seas, the vessel courses so estimated are subject to errors of several degrees, so that the shore station should not expect highly accurate predictions of position based on reported course and speed.

The shore station equipment consists of communications gear, a plotting board or other display, handwritten voyage plans, and a computer with a keyboard console. For each vessel the computer keeps a ship's file on her progress, corrects ETA's, and searches for possible conflicts. In a "barebones" version, the operator would perform all functions, without a computer or computer-driven display.

This system has the advantages of familiarity, simplicity of concept, minimal shipboard equipment, and moderate demands on the vessel master for communications. Since the shore operator acts as a backup by calling up the vessel if a waypoint ETA has been exceeded, there is some desirable redundancy in the system.

On the other hand, the system is limited in capacity, and forces the SO to spend an excessive portion of his time performing bookkeeping duties (the means to the ends), rather than assessing problems and promoting efficient traffic flow (the ends). As increased traffic causes the communication load factor to increase, the VWS's will encounter frustrating delays in relaying their positions. Also, shore operators will find themselves competing for access to the channel (assuming one common frequency).

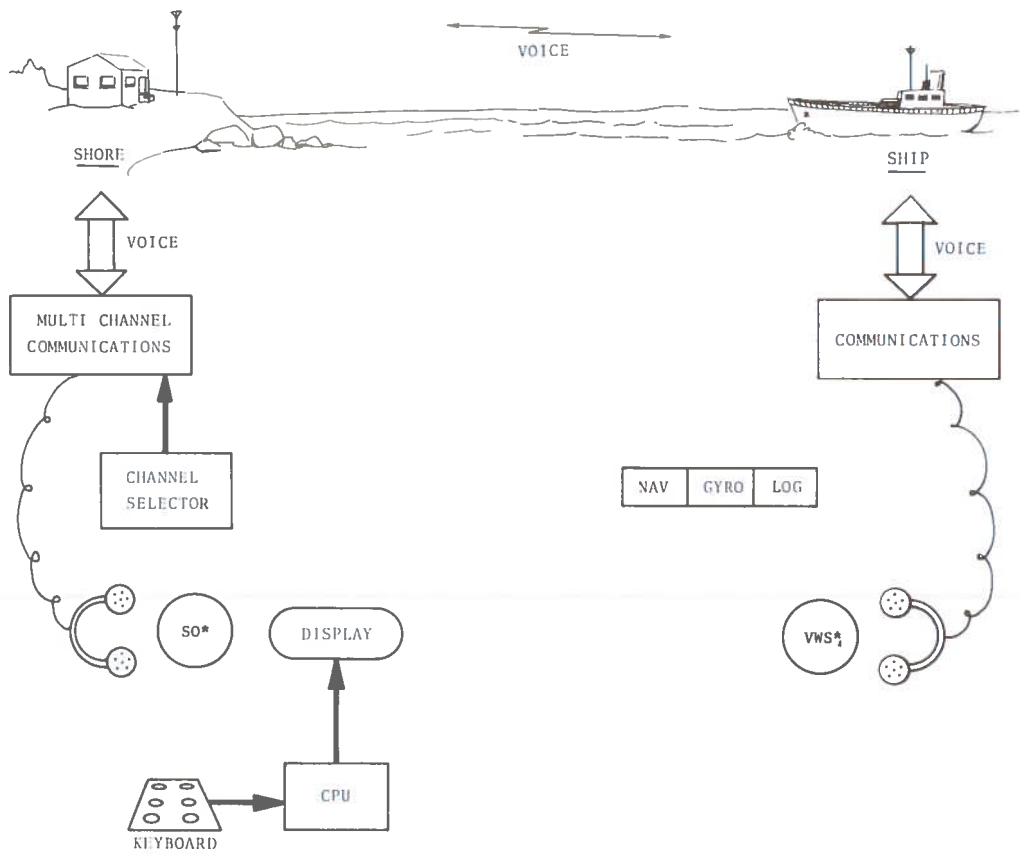

* SO - Shore Operator
 *VWS - Vessel Watchstander

FIGURE G-6. MANUAL MONITORING SYSTEM

From Figure G-1 it is apparent that requiring position reports more than once per hour limits the amount of traffic that can be handled to 30 vessels at most. To get an update rate that would enable a shore operator to provide collision assistance, an update period of 15 minutes or less would be required. This would limit capacity to 7-8 vessels - it would be most effective precisely where it is least needed, i.e., in areas of low traffic density.

From these considerations, and others involving the different purposes of VTS and offshore systems (see Section 5.3.13), it is therefore concluded that there is no case that can be made for monitoring systems using verbal reports of position.

G.3.2.2 Automatic Coded Roll Call, Coded Reply

In this system it is assumed that the onboard encoder module is driven directly by the LORAN-C navigation unit, the ship's log and a heading indicator; the vessel master and vessel watchstander are not involved in the transmission. Course is calculated on shore using consecutive fixes and appropriate tracking filter algorithms: heading and speed are checked for consistency and to indicate course changes. The entire traffic population is automatically interrogated one-by-one at a rate such as once every 5-20 minutes. The updates are no longer geared to significant waypoints, but are updated more often than with reporting systems, so that some missing or garbled shipboard transmissions can be tolerated. In the case of confusing or missing data, the SO can call up the VWS and obtain a verbal clarification.

Since the updates are not related to waypoints, both the computer and the operator must scan the situation and assess the dangers in a periodic fashion. This has an advantage: the operator can give each vessel the appropriate amount of time for assessment, rather than having to interrupt one assessment to acknowledge another vessel's transmission. The computer plays a central role in this system, since it can perform routine monitoring:

a. Comparing actual with intended tracks, and alerting the SO if the deviation exceeds some predetermined value.

b. Projecting tracks and alerting the SO if predicted course would cause a grounding or ramming; even if the voyage plan calls for a turn, the SO may wish to remind the VM of a crucial maneuver.

c. Calculating ETA's to planned course change points, checkpoints, and destination.

d. Calculating CPA's for crossing vessel tracks, and alerting the SO if the CPA is projected to be less than two miles, for example, in the next 20 minutes.

In this system, each SO can handle a large number of vessels. He would spend most of this time performing separation assurance at harbor or fairway entrances, issuing advisories on potential collisions, rammings, or groundings, and communicating with unequipped vessels or those with malfunctioning gear.

The demands on the VWS are minimal, limited mainly to providing data at initial entry, and responding to shore advisories by minor alterations of speed to control arrival time at a harbor fairway entrance, or intersection. The responsibility for collision assessment and avoidance maneuvers, and for avoidance of rammings and groundings would remain completely with the VWS. Advisories would provide helpful information which might not be available or known to him.

The capacity of this system is limited by the time spent in communications with unequipped vessels, and with logging new entries into the system.

The equipment implications are shown in Figure G-7. The ship must have navigation gear, interface equipment, an encoder module, and a data transmitter and receiver (if separate voice and data channels are required).

This system has a high inherent capacity, and enables a high operator workload; it makes minimal demands on the vesselmaster. It does, however, require sophisticated equipment. The automatic monitoring system described in Section 5.2.3 is a system of this type.

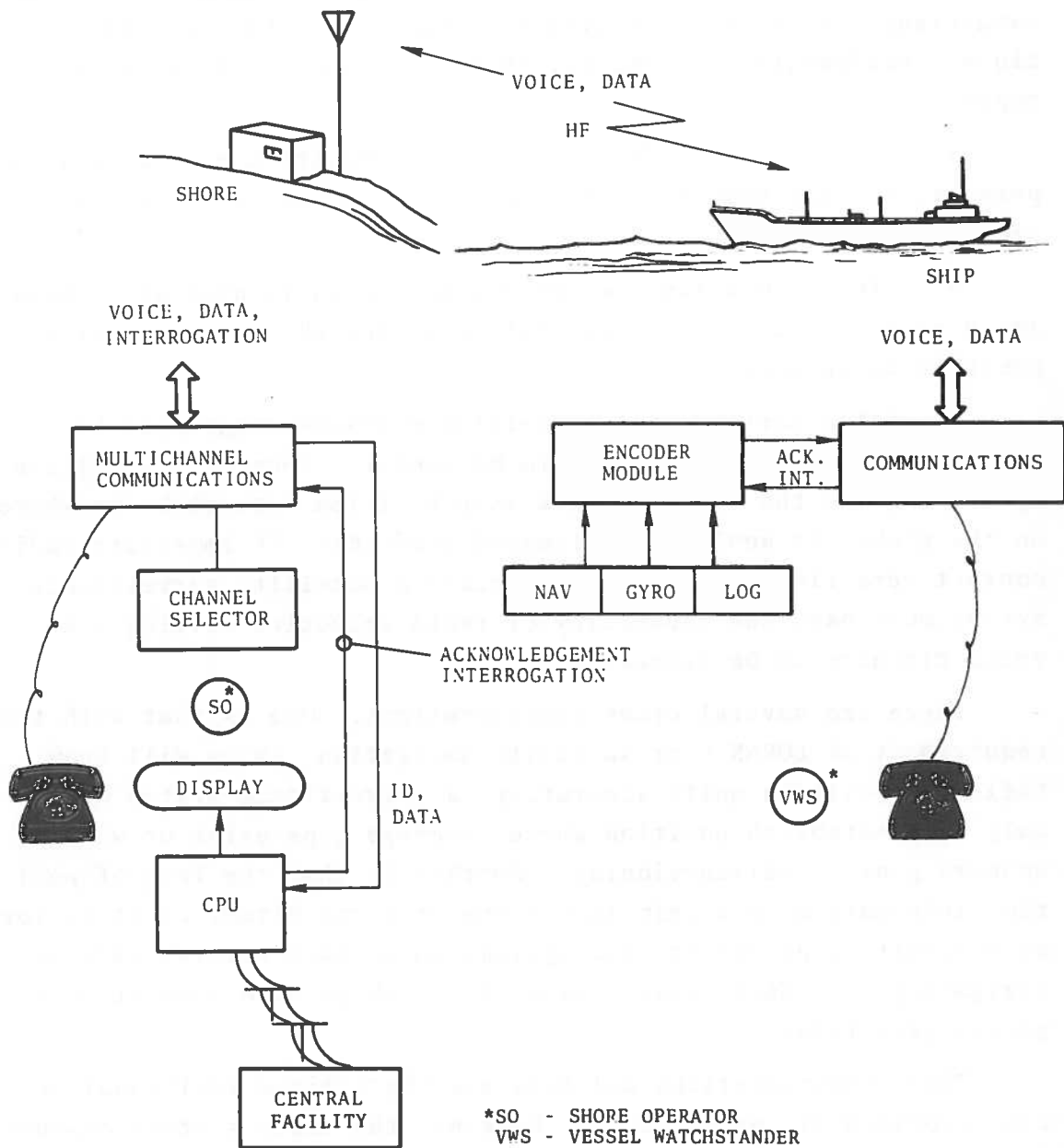

FIGURE G-7. AUTOMATIC MONITORING SYSTEM

G.3.3 Surveillance Systems

Surveillance systems can be ship-initiated or roll-call; their detection can be cooperative or non-cooperative; they can use radar, range/range, or multilateration techniques to establish ship's positions. Fundamentally, however, there are two surveillance system types:

a. Those in which the surveillance position measurement is primary, and the ship's reported position is used only for verification, if at all.

b. Those in which the surveillance data is used as a check and a backup in case of ships' failures, and the ship's reported position is primary.

As stated earlier, the surveillance system range must be matched by communication range to be useful. Thus if a satellite system enabled the shore to know ship position accurately anywhere on the globe, it would be of limited usefulness if immediate radio contact were limited to VHF. Therefore a satellite surveillance system must have the capability of rapid selective calling via voice circuits to be effective.

There are several other considerations. One is that with the requirement of LORAN-C or satellite navigation, ships will know their own position quite accurately; a surveillance system would only help establish position where coverage gaps exist or where onboard gear is malfunctioning. Another is that the loss of position information by a ship is not the critical situation it is for an aircraft in an air traffic system; ships have several ways of navigating. In fact, only a minority of ships have accurate navigation gear today.

These considerations all indicate the limited additional service provided by surveillance. However, the three systems discussed below could offer some real benefits.

G.3.3.1 Direction - Finding (DF) Surveillance

This is a cheap system which can be used as a backup where ship's navigation equipment is questionable. Figure G-8 shows a DF system which provides cross-bearings upon receiving a VHF transmission from a vessel. A vesselmaster requesting such assistance would radio the shore station. The shore operator would set up the DF switches and ask the master to key his VHF transmitter on a particular channel. The SO would then provide the master with LORAN-C time or latitude/longitude coordinates or references to radar targets or visual cues.

DF systems are now being used (single-bearing) to determine the identity of radar targets (Thompson and Reame, 1978).

G.3.3.2 Radar

Radar are used in VTS systems to provide shore operators with a display of vessels and land/buoy echoes. They are expensive to install and maintain, and are limited to 20-30 miles of range. Their biggest advantages are the update rate (typically 15-20 scans per minute) and the references provided to coastal features. There is also the subjective confidence that "you know it's there if the radar says it's there," whereas a synthetic display of data obtained in an automatic monitoring system would occasionally exhibit jumps in ship's positions.

Radars can be used to advantage where they already exist in VTS installations.

As transponders are introduced on board ships, they will provide radars with identity of ships; this is not possible at present.

G.3.3.3 Satellite Surveillance

Since there is presently considerable interest in the applications of satellites to the civil sector, a discussion is included here (see also Appendix H). Figure G-9 shows how a typical satellite surveillance system would operate. Interrogations from shore would trigger a shipboard transponder; the replies would be

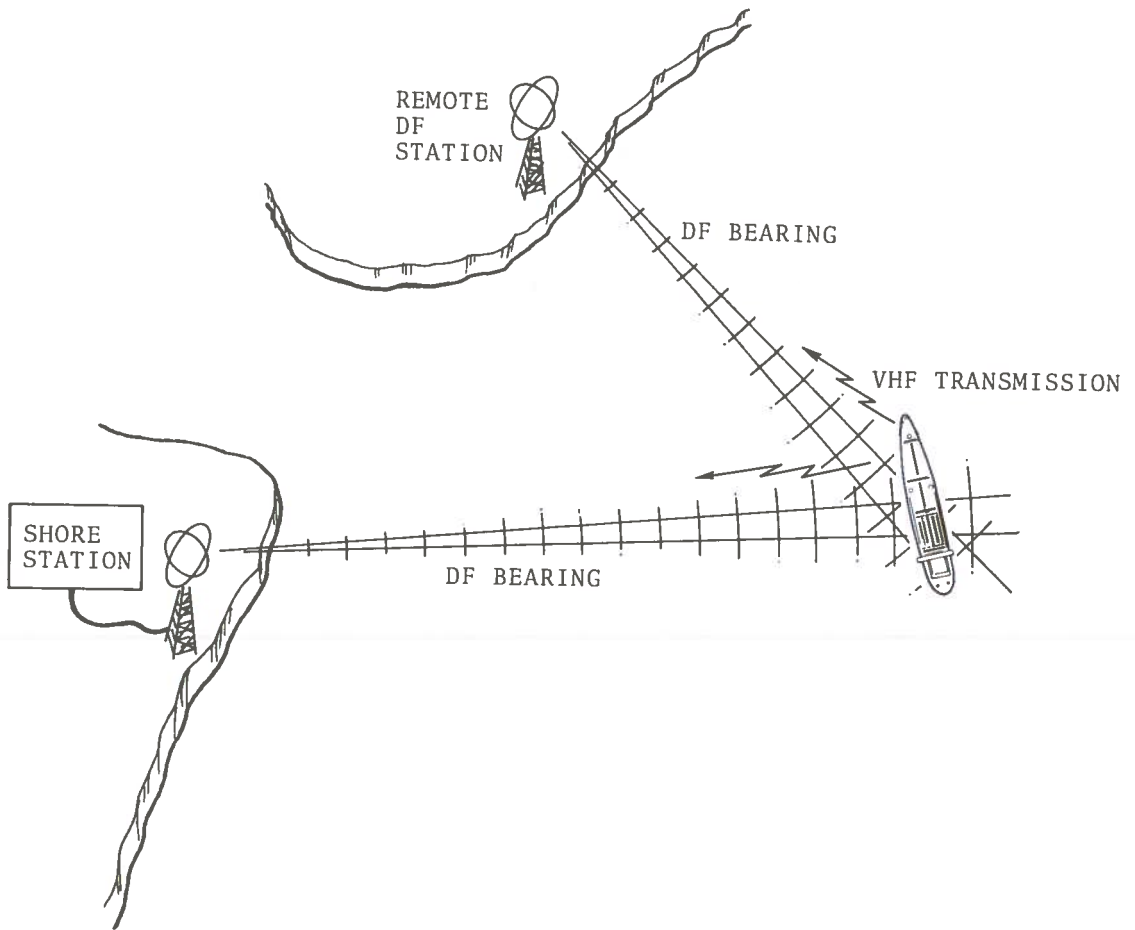

FIGURE G-8. DF SURVEILLANCE SYSTEM

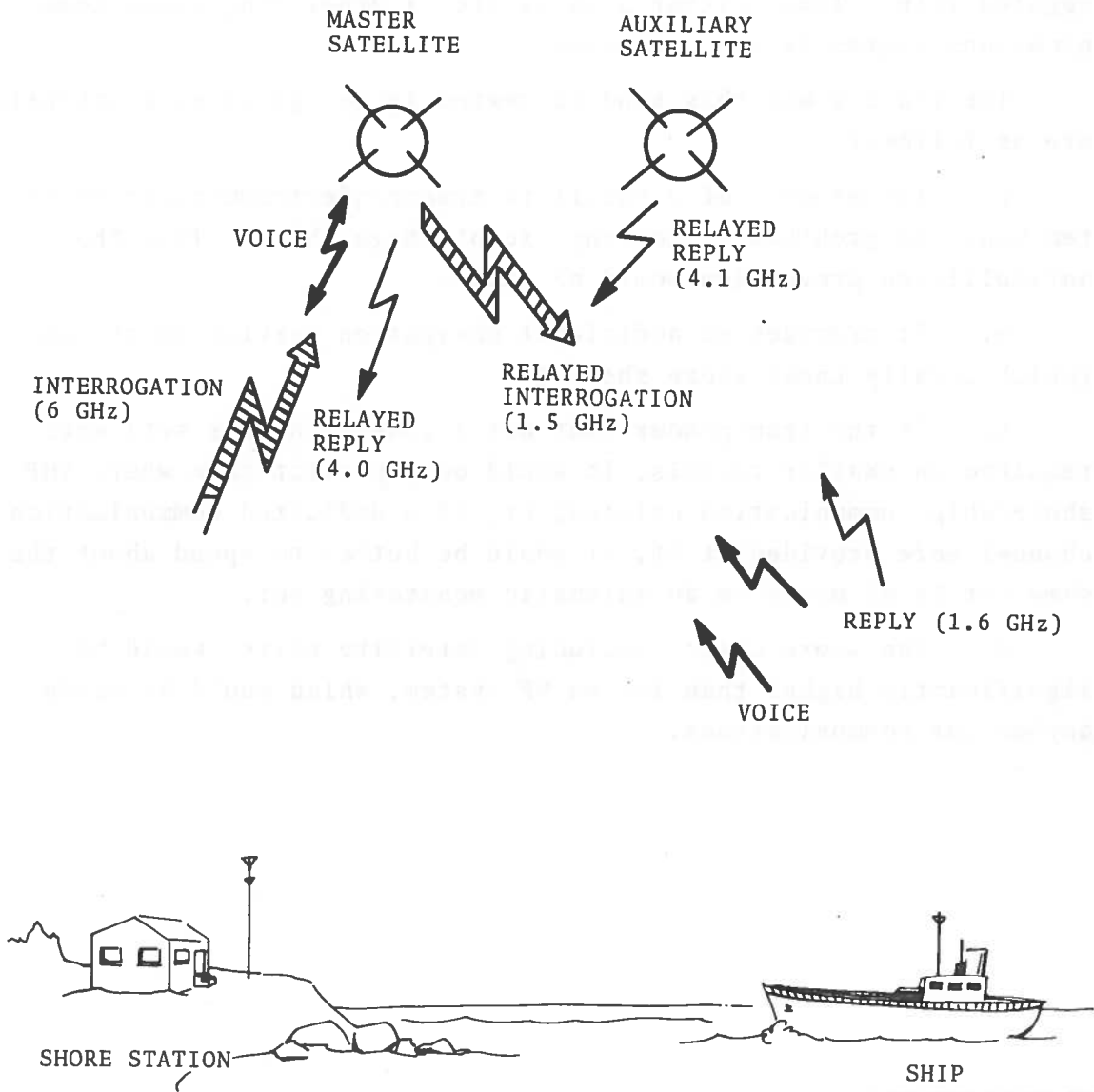

FIGURE G-9. SATELLITE SURVEILLANCE SYSTEM (AFTER MARISAT)

received and the time-of-arrival (TOA) measured. The shore station would calculate the ship's position, knowing the TOA's and the satellites' positions. Clearly, this information is of no value without the capability of immediate communications with the interrogated ship. Thus, either a satellite or other long-range communications system is also required.

The reasons why this kind of system is not given more attention are as follows:

a. The expense of a satellite transponder/communication system would be prohibitive for any except large ships. Thus the anticollision prevention would be small.

b. It provides no additional navigation service to the ship (which usually knows where she is).*

c. If the transponder (but not a communications set) were required on smaller vessels, it would only protect them where VHF shore/ship communication existed; or, if a dedicated communication channel were provided at MF, it would be better to spend about the same (or less) money on an automatic monitoring set.

d. The shore costs, including satellite costs, would be significantly higher than for an MF system, which would be needed anyhow for communications.

*Satellite navigation offers improved accuracy over LORAN-C and other current navigation aids but the presently operational system, Transit, has outages of 1 to 2 hours which reduces the effective accuracy. Also, the study indicated no need for accuracy better than LORAN-C in the offshore areas. The advantage of higher accuracy provided by satellites for the close quarter navigation in ports and harbors, and near the coast are recognized.

G.4 REFERENCES

1. Armacost, R.L., 1977: "A Queuing System Approach for the Design of Coast Guard Vessel Traffic Services Communications," IEEE Trans. Vol. Tech, Vol. VT-25, No. 4, August 1977, p. 239-246.
2. Brown, J.H., Kim, M.C., McGregor, D.N., and Patton, E.D., 1973: "Vessel Traffic Systems Communications Study," ORI Report - CG-D-20-74, 1973.
3. Sites, F.J., 1977: "Communications Via Meteor Trails," 23rd Symposium of the EM Wave Propagation Panel, AGARD, October, 1977.
4. Thompson, P.M., and Reame, J.C., 1978, "Identification of Vessels on a Radar PPI by VHF Direction Findings," 1978 RTCM Assembly Mtg, Paper 48.

APPENDIX H

SATELLITES FOR OFFSHORE VESSEL TRAFFIC MANAGEMENT

H.1 INTRODUCTION

In the wake of the Argo Merchant incident and the rash of tank vessel casualties in the U.S. offshore waters during the winter of 1976-1977, recommendations came from several government leaders to use satellites for surveillance and control of these ships. The terms surveillance and control can have several meanings covering the range from the simplified concept of a vessel issuing a once-a-day position report by teletype to a service agency like AMVER* to the sophisticated "spy in the sky" systems which can determine the vessel's identity, position, cargo, and other characteristics down to minute detail. To clarify the point, the terms surveillance and control are defined for purposes of this study to include the following: 1) tracking of a vessel's course either from vessel reports or independent measurements with sufficient frequency and position accuracy to assess the potential risk of a collision, grounding or ramming, and 2) issuing advisory communications, both in general to all vessels and to specific vessels, regarding unusual local conditions and approaching encounters with other ships or other objects which are a potential hazard to the safety of the vessels. The objective of managing vessel traffic in the offshore waters out to 200 miles is to ensure the safety of the marine and coastal environment without deterring the flow of merchant vessels. The two functions identified above may be performed with several different tools, one of which is a satellite system. Satellites should not be arbitrarily selected as the best tool for this task unless the benefits warrant the cost.

* Automated Mutual-assistance Vessel Rescue.

The purposes of this appendix are to summarize the available satellites that are potentially applicable, identify satellites that are planned for the future, describe the features of those most applicable to maritime needs, discuss the costs of satellites and shipboard hardware and attempt to identify the future trends in satellite services. The objective is to portray satellites as a tool that should be carefully examined for the specific task to be performed and their use clearly justified, either on the basis of their capability as it applies to the mission to be performed, or their cost effectiveness versus other alternatives. This technology has developed to the point where there are no mysteries and no "magic" in what satellites can and cannot do. On the other hand, there will likely be surprises in the areas of commerce and business where they can be applied, how well they can perform a task and the cost per user as new applications and market areas are developed in the future.

H.2 SURVEY OF SATELLITES

H.2.1 SATELLITES CURRENTLY AVAILABLE

The term satellites is used in this appendix to mean both individual satellites and satellite systems. Satellites that are currently in orbit and are applicable in some way to the OVTM study are listed in in Table H-1. This table includes a summary of the service available, lifetime of the satellite and cost to the user. It should be noted that both government-owned and commercial satellites are included. Also this includes operational satellites as well as scientific/experimental satellites.

As shown in this table there are only two operational satellite systems - one with communication capability and the other with position-fixing (navigation) capability. The ATS-6 experimental satellite is of limited usefulness because its small coverage area and far westward location provides only West Coast and Pacific Ocean coverage. Also, it is nearing the end of its expected life. The Marisat and Transit satellites have adequate capacity and

TABLE H-1. CURRENT SATELLITES APPLICABLE TO OVTM*

SATELLITE	SERVICE ¹ COVERAGE	LOCATION(S)	EXPECTED LIFE	OWNER AGENCY	COST INITIAL USER	STATUS REMARKS
TRANSIT ^{6,7,8}	Position fixing by Doppler range difference, worldwide, 5 satellites, passive system, position fix rate once every 110 min. max. for 18 min. period, accuracy: 0.1 NM (2-drms) with vessel in motion or 250 ft. with special equipment and not moving.	5 satellites in different polar orbits, low altitude 600 NM	Useful into late 1980's Began commercial use in 1968	U.S. Navy owner and operator.	User Egmt Cost is \$15-35K. No service cost. Cost of each satellite is approx. \$4M.	Operating Frequencies 150 and 450 MHz. Some occasional disturbance due to atmospheric effects. Accuracy between fixes is approx. 0.25 NM. Receiver requires initial input of Lat., Long., and Time of day - GMT.
MARISAT ^{9,10}	Communications: Telex, Voice, Facsimile, and Data - 2400 bps. Capacity is 8 voice channels and 44 Telex channels per satellite. Three satellites cover Atlantic, Pacific, and Indian Ocean. Continuous coverage except areas of western Gulf of Mexico and Southwest of South America (92° to 108° Longitude).	15° W, 176.5° E and 73° E geosynchronous orbits	5 years, 1976-81	COMSAT Gen. Corp. plus RCA, Western Union, and ITT	User Cost: Ship terminal \$62K plus installation. Service: \$6.00/min for telex and \$10.00/min. for voice	Coverage over Indian Ocean to commence in mid-1978. Performance is as planned. Future plans for 56 kbps data link, ship to shore. Satellites are shared with U.S. Navy which uses separate channels. Operating Frequencies 1500/1600 MHz.
ATS-6	Experimental communications: voice, data, telex, facsimile, high rate data. One 20 MHz BW channel. Coverage is approx. 3000 miles east to west and, 500 miles north to south, coverage is steerable. Very limited application for OVTN.	Approx. 153° W longitude, geosynchronous orbit	5 years, 1974-79	NASA	No service cost. User provides own terminal. Cost approx. \$50K satellite cost approx. \$700M	This is a multi-function experimental satellite useful for communications feasibility tests. Lifetime is limited. It is mentioned here for completeness

*Offshore Vessel Traffic Management.

accuracy, respectively, to meet the current projected needs (through 1990) of the merchant vessel fleet operating in the U.S. offshore waters. However, it does not appear from an examination of the casualty data that any additional capability over present communications and LORAN-C navigation is needed for reducing casualties in the offshore waters due to collisions, groundings or rammings. Therefore, the added expense of these satellite equipments and services does not appear to be warranted at the present time for safety applications. There are potential economic benefits that accrue to the user due to increased efficiency of operations and management of resources by having better, more timely communications over great distances. Both systems are currently being used by several firms in the maritime transportation industry and the number of users is increasing.

H.2.2 PLANNED AND PROPOSED SATELLITES

Planned satellites are those which are either under construction or on the "drawing board." Proposed satellites are those which have been recommended for future service, but have not received funding or authorization. This latter group also includes proposals to change the design and function of planned satellites to serve the needs of the maritime transportation industry. The planned and proposed satellites applicable to the OVTM are listed in Table H-2.

The GPS-NAVSTAR program is currently in the concept validation phase. These tests include flying user equipment and making measurements of acquisition time, position determination accuracy and tracking capability using a satellite system of two in-orbit satellites plus an array of ground terminals which simulate orbiting satellites. The tests are limited to the west coast of the U.S. and to only short periods of time that the satellites are in view. However, it is reported by the Department of Defense that these tests successfully demonstrate the basic capability of the scheme. This system must pass several hurdles before it will be adopted as a national standard for navigation. Two major hurdles are: 1) currently the GPS-NAVSTAR is identified as a

TABLE H-2. PLANNED AND PROPOSED SATELLITES

SATELLITE	SERVICE COVERAGE	LOCATION(S)	EXPECTED LIFE	OWNER AGENCY	STATUS REMARKS
GPS-NAVSTAR ¹¹	Position fixing, velocity, heading, precision time, passive system-user equipment measures position, Worldwide coverage when fully operational. Accuracy: 100 meter and 10 meters-high accuracy. Initial acquisition times is less than 10 minutes and refresh time is approx. 2 minutes	Full system is 24 satellites, 63 deg. inclined orbit, medium altitude, 12 hour orbit period, equally spaced around globe	Each satellite lift is 5 to 7 years. When operational spares replace satellites for continuity of coverage	Dept. of Defense	Planned operational dates are 2 dimensional Nav. - 1982 3 dimensional Nav. - 1986 - full, worldwide systems of 24 satellites. User equipment costs estimated from \$15K to \$35K in production quantities. Signed design requires complex receiver/processing circuitry which results in high receiver costs. The civil user pays penalty because of military signal requirements. A separate signal for the civil user would be advantageous.
MAROTS ^{12,13}	Communications (similar service as MARISAT). Voice, telex, data, facsimile, high speed data. Capacity: shore to ship - 38 chan. ship to shore - 50 chan. An additional objective includes propagation and modulation studies. This satellite is designed for the concurrent conduct of operational communications and various experiments. Worldwide coverage planned.	Initially: Indian Ocean and Atlantic Ocean - one satellite each location. Possible future addition of two satellites for worldwide coverage. Geostationary orbits.	7 years 1st launch in early 1978 failed, future launches delayed.	European Space Agency	Initial purpose was to serve operational needs identified by IMCO to supplement coverage and services of MARISAT which serves the U.S. Navy as its primary function. Now MARISAT has sufficient availability and coverage (three oceans) to meet the maritime needs. One proposal is to hold satellites and use as replacements for MARISAT beginning in 1981.
INMARSAT ¹⁴	Communication and position fixing services plus special services, e.g., television for medical emergencies. Worldwide coverage between 70°N and 70°S latitude	Undefined number of satellites current plan is 6, if position fixing is included.	7 years	Multinational ownership, management has not been named.	This system is in the technical and organizational planning stage. This is conceived as an operational system following MAROTS and MARISAT. Needs IMCO acceptance and designation of an international management organization.
SEASAT ^{15,16}	Ocean monitoring of meteorological conditions is primary mission. Mapping of wave patterns, ice movement esp. icebergs. Also, tracking of ships and oil slicks. Satellite will circle the earth 14-1/3 times daily with an orbital period of nearly 100 min. It will cover 95% of the earth's surface in a 36 hr period, given the instruments cover 1000 mile wide path.	800 km altitude near polar orbit, inclined 108 deg. to the equator	Experimental	NASA, NOAA, NSF, USCG and USGS	This is anticipated to be the prototype of an operational program possibly starting in the mid-1980's. Surveillance detection resolution is 25 meters within the 100 km instrument swath of synthetic aperture radar. Detection functions in moderate rain, dense fog and clouds. A second instrument, narrow beam radar altimeter, can measure the distance from satellite to the ocean surface to within + 10 cm RMS. This instrument has a footprint 1.6 km wide on calm seas at the nadir.

military system with control of operation under the Department of Defense and the needs of the civil user community are of secondary importance, and 2) the cost of user equipment is significantly greater than LORAN-C, the alternative system, such that a large part of the small ship and tug/barge owners are likely to oppose making such a great financial investment considering the benefits derived. Currently there is effort in the Department of Transportation and National Aeronautics and Space Administration to develop techniques and hardware that will lower the cost of user hardware to a competitive level.

The MAROTS satellite system, as indicated in Table H-2, is under construction and will be available for launch over the next two years. Consideration is being given to modifying the ground-to-satellite links to operate at C-Band so as to be compatible with the MARISAT Ground Terminals. This would allow the MAROTS satellites to serve as direct replacements for the MARISAT satellites and preserve the continuity of maritime satellite communications which is greatly needed for acceptance and growth of the user population. One service which is not provided in the same package is position fixing. While accurate position fixing is available with the Transit satellites, this requires separate receiver hardware because of the difference in operating frequencies. A consolidation of functions and services into one satellite-user package would likely increase the interest of ship owners. However, to provide position-fixing service would require a minimum of six satellites in orbit which is a substantial increase in system investment and would only be justified if the user market is favorable.

INMARSAT is intended to be an operational system to follow the MARISAT and MAROTS satellites in the 1980's. This program is currently bogged down in organizational, management and financial debates which are complex and difficult to resolve in a timely manner because of the international nature of the system. These issues should be resolved soon or the program may die and the only option left open to the mariner for satellite service

may be the Russian aeronautical and maritime satellite system currently being planned. It is in the interest of the U.S. and the western countries to push the development of the INMARSAT system.

The Seasat-A satellite offers the potential for passive detection and surveillance of tank vessels and hazardous cargo ships which approach the U.S. coasts. This capability does not currently permit identification of the vessel, but it does plug a hole inherent in many techniques for monitoring and management of vessel traffic in the U.S. offshore waters by providing information about the presence of ships that may avoid reporting and complying with a system such as the "Passport" system discussed in the main text. Two types of vessels are likely to avoid reporting: 1) those called "innocent passage vessels" which are passing near, but not bound for, a U.S. port, and 2) those called "rogues" who refuse to be a part of any system. Statistics show about 5 percent of the merchant vessels are of the "rogue" category. A satellite of the Seasat-A type could potentially detect and report the presence and location of these types of vessels to a monitoring facility which could then employ local-aircraft or inspection vessels to investigate and take appropriate action. Further analysis is needed to determine if this is a cost-effective approach, but the concept is appealing and may be a low-cost fallout of the ocean monitoring meteorological satellite program.

H.3 TRENDS IN FUTURE SERVICES AND COSTS

H.3.1 TECHNOLOGY

Technology advancements in satellites and user equipment are likely and can be expected to occur in the next decade. These advancements will occur in the satellite booster with the advent of the space shuttle, in the spacecraft with more efficient prime power systems, RF systems and higher gain antennas, and in user equipment with improved voice and data modems using advanced multiplexing and modulation techniques, with increased capacity

microprocessors, and with higher power, more efficient RF transmitters.

The primary communications methods between ship and shore in the past were telegraphy and voice telephone, with the later addition of telex. Communications of the future will be heavily oriented to high-speed data via a teletype terminal for operator access. High-speed data is feasible, practical and cost-effective with continued development of high-capacity, high-speed microprocessors coupled with wideband satellite channels which greatly reduce the cost per message unit.

One example of new technology that could significantly lower the cost and attract mariners to use satellites for communications is an Adaptive Multibeam Phased Array spacecraft antenna which is to be tested on the Spacelab. This is called the AMPA experiment and will be conducted by the National Aeronautics and Space Administration.¹ This satellite antenna offers the capability of high-quality communications (voice and data) while only requiring a small user terminal. This antenna is designed to operate in the L-Band (1.5 GHz) allocated for maritime mobile satellite communications. With this antenna on a satellite, the ship terminal is estimated to cost between \$5,000 and \$10,000 for voice and data communications (not including installation). This is considerably lower than the current \$62,000 cost of a MARISAT ship terminal.

H.3.2 CAPACITY AND COST

The advent of the space shuttle will permit the launching of large payloads at lower cost than conventional boosters. Thus, much larger capacity satellites will be common in the next decade and this increased capacity will result in lower cost to the individual user. A large capacity satellite will serve a large number of users with different communications requirements the same as terrestrial circuits do today. To illustrate the point, one need only to look at the history of Intelsat. Intelsat I, launched in 1965, had a capacity of 240 voice circuits, while Intelsat IV-A, launched in 1975 has a capacity of 24,000 voice

circuits.² In this same time period the user charge went from \$32,000 in 1965 to \$8,460 in 1975 for a one-way telephone channel.³ In 1976, the Intelsat organization projected that by 1994 the requirements for satellite communications will be greater than 300,000 channels.⁴ This will be accomplished by advances in satellite antenna dual-polarization and spot beam, use of wide band channels and advanced digital modulation including forward error correction and bandwidth conservation techniques.

Commercial satellites are also employing small rooftop user terminals costing approximately \$50,000 which permit direct access from the corporate plant to the satellite, thus saving the costs of leased land lines from the plant to a centralized satellite ground terminal which is currently the most common practice.

Analysis of the relative cost of satellite versus telephone land lines for intra-continental U.S. communications indicates that satellite circuits (for voice and data quality) save money over AT&T circuits when the distance exceeds 600 miles. The result is that satellites are increasing for business communications between terrestrial points within the U.S.

H.4 SUMMARY

Satellites will play an important role in ship-to-shore communications in the future. Currently the larger vessels are the only ones that realize a cost advantage in using satellites for communications. Widespread use of satellites on merchant maritime vessels will depend on: 1) the development of low cost user equipment, 2) multiple services by one set of user equipment and 3) low user charges. As indicated earlier, satellite technology appears to be on the horizon which will greatly reduce the cost of user equipment. Multiple services by one set of user equipment is defined as equipment that will serve both communications and position fixing functions. From the viewpoint of investment costs, maintenance, equipment space and operator staffing and training, it does not make much sense to have two sets of satellite equipment on a ship, one for communications and

a second for position fixing, (e.g., Marisat and Transit), when one set of equipment could do both jobs. Effort is needed in planning and designing future operational maritime satellites, such as INMARSAT, to provide both communications and position fixing services that are cost beneficial to the user.

The results of the study indicate the present VHF, MF and HF communications systems and the LORAN-C navigation system are sufficient for offshore vessel traffic management requirements until at least 1990. However, the greater demand and poor reliability of HF communications will very likely call for the improvement available by the use of satellites. Therefore, it would seem essential that a future operational satellite be fully developed and ready for use by the early 1990's. INMARSAT is an attempt at filling this need but a strong push is needed to get agreement on the program and management organization so progress can be made before nations give up in futility and the world finds itself dependent on a Russian-owned satellite system for maritime services in 1990-2000.

H.5 REFERENCES

1. Spacelab Adaptive Multibeam Phased Array (AMPA) Experiment, S.H. Durrani, et al, WESCON, Oct. 1977.
2. Telecommunication Transmission Media, Leang P. Yeh, Telecommunications, Vol. 10, No. 4, April 1976.
3. Intelsat: Then and Now, Telecommunications, Vol. 9, No. 9, Sept. 1975.
4. Intelsat Projects 15-Fold Traffic Increase, Katherine Johnsen, Aviation Week and Space Technology, Apr. 19, 1976.
5. Influence and Availability of Maritime Satellite Communications and Navigation, J.D. Parker, International Conference on Maritime and Aeronautical Satellite Communication and Navigation, March 1978.
6. NATIONAL PLAN FOR NAVIGATION, DEPARTMENT OF TRANSPORTATION, Report No. DOT-TST-78-4, Nov. 1977.

7. Analysis of Potential Applications of Space Telecommunications Systems to U.S. Coast Guard missions, E.J. Mueller, et al., Westinghouse Corp. Final Report, prepared for the U.S. Coast Guard, Report No. FIS-75-0018, Contract DOT-CG-31882-A, Oct. 1975.
8. Satellite Navigation - Now an Economical Choice for Maritime Vessels, R.D. Cashion and G.A. Hunt, RTCM Symposium, Vol. 4, Radio Determination, April 1977.
9. MARISAT Satellite Communications System, D.W. Lipke, et al., COMSAT TECHNICAL REVIEW, Vol. 7, No. 2, CTR-C7(2)-351-662, Fall 1977.
10. Performance of the Marisat Communications System, E.J. Martin and D.W. Lipke, International Conference on Maritime and Aeronautical Satellite Communications and Navigation, March 1978.
11. Navigation Planning - Need For a New Direction, Comptroller General Report to the Congress of the U.S.A., No. LCD-77-109, March 1978.
12. Outline of a Forward-Looking Maritime Mobile Satellite System, A.E. Baker and J.A.P. Vandenkerckhove, Ibid 5.
13. The Role of the MAROTS Experimental Program in the Future Development of Maritime Satellite Ship Equipment, S.R. Temple, Ibid 5.
14. Methods of Radio Determination for INMARSAT, G. Frenkel, Ibid 5.
15. Oceans Monitored by Seasat, Microwave Review, Microwave Systems News, Jan. 1978.
16. SEASAT-A Could Spur Operational Plan, Sapce Technology, B.M. Elson, Aviation Week and Space Technology, Dec. 12, 1977.

APPENDIX I

EVALUATION OF OPERATIONAL FEATURES AND SYSTEMS

I.1 INTRODUCTION

This Appendix contains the detailed scoring of the 55 groundings, 17 collisions, and 6 rammings that comprise the casualty data base (see Appendix C). Only the scores of the OVTM team at TSC are included. Members of the Boston Marine Society, the Coast Guard, and the Massachusetts Institute of Technology independently assessed the casualties. Their comments and observations were compared, and where differences existed, the differences were discussed with them. Their inputs were invaluable in placing the scores in the proper perspective. Location of instruments on the bridge, attitudes toward new instruments or new requirements, training and workload requirements, and port versus drydock repairs were all considerations where their experience helped shape the recommendations.

The first section deals with operational features: services available to the mariners. The second section deals with systems, from rules and procedures to sophisticated on board and/or shore-based equipment. Some operational features appear in several systems, and some systems incorporate several operational features. The final section is an example showing the evaluation technique.

I.2 OPERATIONAL FEATURES

The scores of the operational features were based on the assumption that any equipment involved was on board and working, and that any required procedures were, in fact, followed. Each casualty in the data base was evaluated against the list of operational features. Scores were assigned on a scale of 0-10 points, where each point represents a probability measure of about 10%. That is, a point score of 7 means that the team (by consensus) believed that the operational feature had about a 70% chance of preventing the casualty. It was not felt to be realistic to assess probabilities to any finer degree than this.

Subjectively, scores of 9-10 meant "highly likely", 6-8 meant "probably"; 2-4 meant "possibly"; 1 meant "unlikely"; 0 meant "highly unlikely". The score of 5 was a compromise score. Often the question was phrased, "if 10 bridge officers in this situation had such-and-such a feature available, how many would have used it and avoided the accident?"

There are several ways in which data are presented to a bridge officer that need to be considered in determining the most effective operational features. In approximate order of increasing sophistication, they are:

Checking Requirement - A requirement that the conning officer make a record of, or report on, specific data. This serves as a reminder.

Advisory - A general broadcast from shore giving weather, tidal, or congestion information.

Ability to Obtain - Indicates availability of information, but requiring effort to operate instruments to get it.

Display - A continuously updated, visual presentation of data; available without effort.

Alert - An audible sound or flashing light which attracts the attention of officers on the bridge, indicating that a situation exists which might be dangerous.

Warning - An audible sound which attracts the attention of officers on the bridge, indicating that instruments have determined that a dangerous situation exists.

In addition, there are other features that might reduce the probability of a casualty, which do not fit the previous definitions:

Incentive - An instrument, regulation, or procedure which improves bridge discipline.

Training - A period of education, initially and/or periodically, which familiarizes bridge officers with instruments and procedures.

Visual/Audio - Aids-to-navigation that are visible, and may have identifying bell, horn, or whistle.

Charting - Restrictions on vessel movement, indicated on Charts or Aids to Mariners.

The list of 34 operational features is given in Table I-1, along with the scores assigned by the OVTM team for each casualty in the data base. The numbering is sequential, so that the characteristics of each case can be traced by using Appendix C.

The remainder of Section I-2 is devoted to a description of each operational feature and the scores and their rationale. Specific factors are cited which are relevant in assessing the feature, such as geographical location, visibility, etc. Each subsection consists of (1) a description of the operational feature, (2) a scoring summary, (3) specific issues that shed light on the application of the feature, (4) the histogram of scores with point totals in the legend, and (5) further explanations in some cases. On each histogram, collision bars are cross-hatched, ramming bars are dotted, and grounding bars are plain.

The Specific Prevention Index (SPI) is defined as the total point score divided by the number of cases where the feature point score was non-zero (defined for groundings, collisions, rammings, or combinations, depending on the context). While the number of cases provides a measure of the frequency that a particular feature shows up as being helpful, the SPI provides a measure of effectiveness for those cases where it was at all beneficial.

The Probability of Prevention (PP) is defined as the total point score divided by the total number of cases in the category; it is the basic measure of effectiveness. Thus two features could have the same probability of prevention, and have widely varying SPI's. For example, suppose that of 17 collisions, feature A had a point score of 3 in each of 10 cases, while feature B had a point score of 10 in each of 3 cases. Each would have an overall PP of 18% (30/170); feature A would have an SPI of 3, while B would have an

TABLE I-1. OPERATIONAL FEATURE SCORES FOR EACH CASUALTY

GROUNDINGS (1-17)	1	2	3	4	5	6	7	8	9	10	11	12	13	14	15	16	17
1. Training	1	2	3	3		2	1		2	5		1	1		1	1	2
2. Rules of the Road																	
3. Prohibited Zones	2			3													
4. Traffic Separation	2									5							
5. Buoy Improvements	3*		6			6*	9				9						1
6. Pilotage Improvements	9			9			10						9	8			
7. Equipment Standards		7					7										
8. Incentive to Repair		1															
9. Mandatory Recorder	1					1											
10. High Accuracy Navigation											2					1	
11. Dependable Position Fix		7				1											
12. Navigation Display	3	9	7			1		6	3	6	1						2
13. Deviation from Track	3	9	9			1		6	3	6	2						3
14. Alert of Deviation	3	10	10			1		7	3	7	3						3
15. Maneuver Alert						7											1
16. Improved Depth Detection		2															
17. Depth Alert	2	8	4		2	1		3	9	3		3	8	2			1
18. Forward Fathometer	8	10	8	9	4	6		9	1	9	7	9	9	5			2
19. Depth Mapping Alert	8	10	6	10	4	7	6	9	9	10	7	10	9	6	4		7
20. RACONS	1					5	7										4
21. Dependable Radar Returns																	
22. Stationary Radar Targets																	
23. RACONS on Oil Platforms																	
24. Radar Alert																	
25. Proximity Warning																	
26. Radar Plotting																	
27. Conflict Alert																	
28. Radio Contact																	
29. Maneuver Intent																	
30. Communication																	
31. General Advisory		1						10		10						4	6
32. Checklist			3				6	4		5		9					
33. Manual Monitoring			6			7	4	7	10	7		9	4	3			
34. Automatic Monitoring	4	10	9	10		7	4	10	10	9	4	9	7	10			3

*Not included in system scores.

TABLE I-1. OPERATIONAL FEATURE SCORES FOR EACH CASUALTY (continued)

GROUNDINGS (18-34)	18	19	20	21	22	23	24	25	26	27	28	29	30	31	32	33	34
1. Training			3	2		4	2	2		1	2	3	3	1	1		1
2. Rules of the Road											6						
3. Prohibited Zones	3					2	4			9							
4. Traffic Separation																	
5. Buoy Improvements	2*					3*			10		6*						
6. Pilotage Improvements	7						8							7			
7. Equipment Standards			10	9		3											
8. Incentive to Repair			8	3													
9. Mandatory Recorder			2			4	1	1		1	1	1		1			
10. High Accuracy Navigation					7												1
11. Dependable Position Fix			7	9						9							
12. Navigation Display	4		7	9	3	10	6		2	9	9	7		3			
13. Deviation from Track	4		7	10	3	10	6		2	9	9	9		3			
14. Alert of Deviation	4		7	10	3	10	6	6	2	9	9	10		3			
15. Maneuver Alert	6		3														
16. Improved Depth Detection						4											
17. Depth Alert		2	5	3		4	3				3	9		2	3		
18. Forward Fathometer	8		10	7	8	8	8	4	7	5	9	9		2	5	3	
19. Depth Mapping Alert	7	4	9	6	6	8	8	2	6	7	8	9		6	10	2	
20. RACONS	4					9	9					5		1			
21. Dependable Radar Returns																	
22. Stationary Radar Targets																	
23. RACONS on Oil Platforms																	
24. Radar Alert																	
25. Proximity Warning																	
26. Radar Plotting																	
27. Conflict Alert																	
28. Radio Contact																	
29. Maneuver Intent																	
30. Communication																	
31. General Advisory			2				3								8		3
32. Checklist			9	6		5						3					
33. Manual Monitoring	6		4	6	7	10	3	2		2		3	6		5		
34. Automatic Monitoring	9		8	9	7	10	9	6	3	10	9	10	6		5		

*Not included in system scores.

TABLE I-1. OPERATIONAL FEATURE SCORES FOR EACH CASUALTY (continued)

GROUNDINGS (35-51)	35	36	37	38	39	40	41	42	43	44	45	46	47	48	49	50	51
1. Training	7	1		1	4	4	2	4	2	1	3	2	3				
2. Rules of the Road																	
3. Prohibited Zones										2							
4. Traffic Separation										6							
5. Buoy Improvements	1*	9	2*		10			5*	9*	2*		10					
6. Pilotage Improvements		10		9												8	9
7. Equipment Standards	2		6					8									
8. Incentive to Repair	3							7		1							
9. Mandatory Recorder		1			2												
10. High Accuracy Navigation																	
11. Dependable Position Fix			10		1			1	8	7							
12. Navigation Display	6	8	10		2			4	8	7	3	4	7				
13. Deviation from Track	7	8	10		2		2	6	8	8	3	5	7				
14. Alert of Deviation	8	9	10		3		2	10	8	10	3	6	9				
15. Maneuver Alert		1										4					
16. Improved Depth Detection				3													
17. Depth Alert		8		1			6	9	6	4			8	4	6		
18. Forward Fathometer	6	8	8	9	8		2	9	9	9	2	6		2	6		7
19. Depth Mapping Alert	6	8	7	9	10		4	10	10	9	4	7	7	3	6		8
20. RACONS	8				5			2	10	2		3	2				
21. Dependable Radar Returns																	
22. Stationary Radar Targets																	
23. RACONS on Oil Platforms																	
24. Radar Alert																	
25. Proximity Warning																	
26. Radar Plotting																	
27. Conflict Alert																	
28. Radio Contact																	
29. Maneuver Intent																	
30. Communication																	
31. General Advisory						2			7								
32. Checklist				7				10		6							
33. Manual Monitoring	3	9	7	6	6		4	4	9	8	6	5	7		10	6	3
34. Automatic Monitoring	10	10	8	9	8		6	10	10	9	7	8	10		10	6	10

*Not included in system scores.

TABLE I-1. OPERATIONAL FEATURE SCORES FOR EACH CASUALTY (continued)

FOUNDINGS (52-55)	52	53	54	55															
1. Training	1	1	2	2															
2. Rules of the Road																			
3. Prohibited Zones				6															
4. Traffic Separation																			
5. Buoy Improvements		10																	
6. Pilotage Improvements		10		7															
7. Equipment Standards																			
8. Incentive to Repair																			
9. Mandatory Recorder			2																
10. High Accuracy Navigation																			
11. Dependable Position Fix																			
12. Navigation Display	2	4		2															
13. Deviation from Track	2	7	4	2															
14. Alert of Deviation	2	9	10	2															
15. Maneuver Alert	7																		
16. Improved Depth Detection																			
17. Depth Alert																			
18. Forward Fathometer	5		9	6															
19. Depth Mapping Alert	8	6	9	8															
20. RACONS																			
21. Dependable Radar Returns																			
22. Stationary Radar Targets																			
23. RACONS on Oil Platforms																			
24. Radar Alert																			
25. Proximity Warning																			
26. Radar Plotting																			
27. Conflict Alert																			
28. Radio Contact																			
29. Maneuver Intent																			
30. Communication																			
31. General Advisory																			
32. Checklist																			
33. Manual Monitoring	3	7	3	2															
34. Automatic Monitoring	3	9	7	6															

TABLE I-1. OPERATIONAL FEATURE SCORES FOR EACH CASUALTY (continued)

COLLISIONS (1-17)	1	2	3	4	5	6	7	8	9	10	11	12	13	14	15	16	17
1. Training	3		3		2	4	3	3	3	2	2	2	2	2	2	3	1
2. Rules of the Road		3															
3. Prohibited Zones																	
4. Traffic Separation										9		7					9
5. Buoy Improvements																	
6. Pilotage Improvements			3	7										9			
7. Equipment Standards			9														
8. Incentive to Repair																	
9. Mandatory Recorder																	
10. High Accuracy Navigation																	
11. Dependable Position Fix														3			
12. Navigation Display														3			
13. Deviation from Track														3			
14. Alert of Deviation														3			
15. Maneuver Alert																	
16. Improved Depth Detection																	
17. Depth Alert																	
18. Forward Fathometer																	
19. Depth Mapping Alert																	
20. RACONS																	
21. Dependable Radar Returns			10														
22. Stationary Radar Targets								8									
23. RACONS on Oil Platforms																	
24. Radar Alert		4	4				6	3				4			7	4	
25. Proximity Warning		8	10	6	4		9		2	1				3	7	6	
26. Radar Plotting		1			4			2	6	1	4	6		3		3	
27. Conflict Alert	9	9	10	6	5		9	10	6	5	6	7		7	10	7	
28. Radio Contact	6	8	9		6			3	4	3	4	10		8	6	7	
29. Maneuver Intent		8			7				9	7		6		2	4	3	
30. Communication	10	9	9	1	9	2	4	9	9	10	9	3		8	8	9	
31. General Advisory													7				
32. Checklist																	
33. Manual Monitoring	6	8	4	3	7		7	7	9	10	8	8	7	6	9	6	
34. Automatic Monitoring	10	9	10	7	9		9	10	10	10	10	8	7	6	9	10	

TABLE I-1. OPERATIONAL FEATURE SCORES FOR EACH CASUALTY (continued)

RAMMINGS (1-6)	1	2	3	4	5	6													
1. Training	7		1			2													
2. Rules of the Road																			
3. Prohibited Zones																			
4. Traffic Separation																			
5. Buoy Improvements																			
6. Pilotage Improvements																			
7. Equipment Standards																			
8. Incentive to Repair																			
9. Mandatory Recorder																			
10. High Accuracy Navigation																			
11. Dependable Position Fix		9			10	6													
12. Navigation Display		9		1	10	7													
13. Deviation from Track		9		2	10	9													
14. Alert of Deviation		9		4	10	10													
15. Maneuver Alert						10													
16. Improved Depth Detection																			
17. Depth Alert																			
18. Forward Fathometer																			
19. Depth Mapping Alert																			
20. RACONS					10	4													
21. Dependable Radar Returns		9																	
22. Stationary Radar Targets																			
23. RACONS on Oil Platforms		9			10	10													
24. Radar Alert																			
25. Proximity Warning		7		9	10	10													
26. Radar Plotting																			
27. Conflict Alert		7		9	10	10													
28. Radio Contact																			
29. Maneuver Intent																			
30. Communication																			
31. General Advisory																			
32. Checklist																			
33. Manual Monitoring	4		3	3		6													
34. Automatic Monitoring	4	10	3	3	9	10													

SPI of 10. This would imply that while feature A would have frequently been beneficial, it would not have been too helpful in a particular case; feature B would not usually be helpful, but would be extremely effective when it was needed. Features that have high SPI's are those that are best in combinations with other features. SPI's above 5 are considered good, while SPI's below 5 are less so.

The overall probability of prevention is the total point score divided by 10 times the number of casualties in the data base times 100%. It should be interpreted within a context, however. Collision avoidance aids can't usually be expected to prevent groundings, while a depth sounder can't usually be expected to prevent collisions.

I.2.1 MORE INTENSIVE AND PERIODIC TRAINING

This operational feature was postulated in order to obtain an indication of careless navigating, i.e., where a well-trained, conscientious and alert seaman would probably not have had an accident. Human error was noted in 74% of the cases, which suggests that training would have been helpful. The kinds of human errors that occurred were:

- (a) Gross Inattention (8 cases)
- (b) Infrequent Position Fixing (7 cases)
- (c) Misjudging of Currents (7 cases)
- (d) Failure to Use depth sounder (7 cases)*
- (e) Poor Handling of Barge (5 cases)
- (f) Poor Use of Charts (3 cases)
- (g) Failure to Cross-Check Instruments (9 cases)
- (h) Passing Too Close to Known Reef or Shoal Area (6 cases)
- (i) Poor Radar Usage (17 cases)
- (j) Lack of Proper Lookout (4 cases)
- (k) Lack of Defensive Seamanship (4 cases)

The fact that 80% of the casualties took place at night or in reduced visibility underscores the lack of proper navigation procedures. The lack of properly licensed mates was noteworthy. It is clear that much can be done in this area.

The TSC team, while citing lack of good bridge discipline in 58 of 78 cases, gave training low scores: the specific prevention index (SPI) was 2.4. This results in an overall probability of prevention of 18%. The reason why the scores were so low was primarily the doubt that a training course, a refresher course,

*Since the use or non-use of depth sounders was rarely mentioned in the accident reports, this figure may well have been higher. A depth sounder is also called a "Fathometer" which is the registered trademark of a Raytheon depth sounding instrument.

or a tough written licensing examination would overcome bad habits acquired during the mariner's experience at sea. The three members of the Boston Marine Society, on the other hand, believed that training would have been quite helpful, and gave this feature much higher scores. They were, however, skeptical whether foreign flag vessel owners would go to the expense of properly training their officers.

The question of implementation of a training system is treated in Section 5.2.7.

OPERATIONAL FEATURE 1: MORE INTENSIVE AND PERIODIC TRAINING

(1) SCORING SUMMARY

POINT SCORE/NO. OF CASES:

- GROUNDINGS 90/41
- COLLISIONS 37/14
- RAMMINGS 10/3

Nature of Casualty	No. of Cases	% of Cases	Prob. of Prev.	Spec. Prev. Index
Groundings (55)	41	75%	16%	2.2
Collisions (17)	14	82%	22%	2.6
Rammings (6)	3	50%	17%	3.3
Overall Rating	58	74%	18%	2.4

(2) SPECIFIC ISSUES

Gross Inattention: G-1, 4, 25, 35, 39, 54; C-7, 15

Infrequent Position Fixing: G-20, 23, 36, 43, 45, 47, 52

Misjudging of Currents: G-15, 16, 29, 34, 53; C-13, R-1

Failure to Use Fathometer: G-2, 9, 12, 13, 21, 29, 35

Poor Handling of Barge: G-15, 40; C-17; R-1, 3

Poor Use of Charts: G-7, 15, 32

Failure to Cross-Check Instruments: G-2, 6, 8, 9, 21, 29, 35, 42, 44

Passed too Close to Known Reef or Shoal Area: G-24, 27, 30, 38, 41, 55

Poor Radar Usage: G-2, 3, 8, 17, 25, 28, 29, 35, 47; C-1, 3, 8, 11, 14, 15, 16; R-6

Lack of Proper Lookout: G-46; C-7, 15; R-6

Lack of Defensive Seamanship: C-5, 6, 9, 12

(3) HISTOGRAM OF SCORES

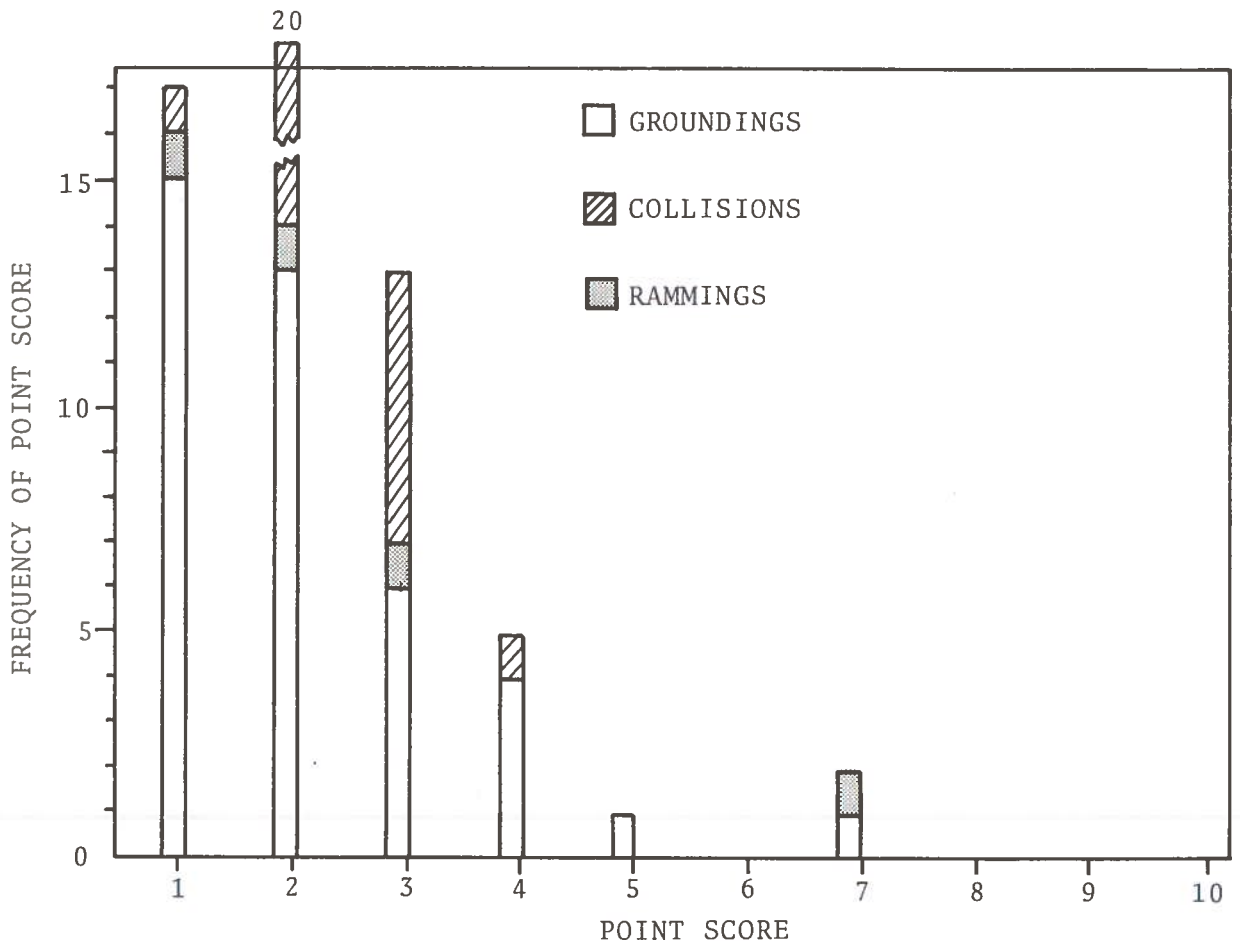

I.2.2 REVISED RULES OF THE ROAD

The 1972 International Convention for the Prevention of Collisions at Sea drafted some major changes in the Rules of the Road, which have since been adopted internationally, and are called the "1972 COLREGS".* This system feature was included to pick up cases where the present Rules might have caused confusion.

In only 2 cases in the data base was it cited: in the first, a 1971 collision, it was noted that the same vessel operating under the new 1972 COLREGS might have taken earlier action as the priveleged vessel in a crossing situation.

Only the second case might involve further changes: there a vessel inbound in a traffic lane, being the burdened vessel in a crossing situation, went out of the traffic lane and subsequently grounded. One suggestion resulting from the study was that a vessel crossing a traffic lane always be the burdened vessel. In the future some on-board instruments may achieve sufficiently widespread usage that rules for their usage may be incorporated into the Rules of the Road, but there were none identified that were certain to hold this potential in the 1985/1990 time frame. However, some ship/ship communication schemes may prove inexpensive and reliable enough to warrant such incorporation at same data in the future.

In sum, this operational feature does not appear to hold promise for reducing collisions, rammings, or groundings.

*These are incorporated into present navigation rules.
(U.S. Coast Guard, 1977)

OPERATIONAL FEATURE 2: REVISED RULES OF THE ROAD

(1) SCORING SUMMARY

POINT SCORE/NO. OF CASES:

- GROUNDINGS 3/1
- COLLISIONS 6/1
- RAMMINGS 0/0

Nature of Casualty	No. of Cases	% of Cases	Prob. of Prev.	Spec. Prev. Index
Groundings (55)	1	2%	1%	3
Collisions (17)	1	6%	4%	6
Rammings (6)	0	0	0	-
Overall Rating	2	3%	1%	4.5

(2) SPECIFIC ISSUES

None

(3) HISTOGRAM OF SCORES

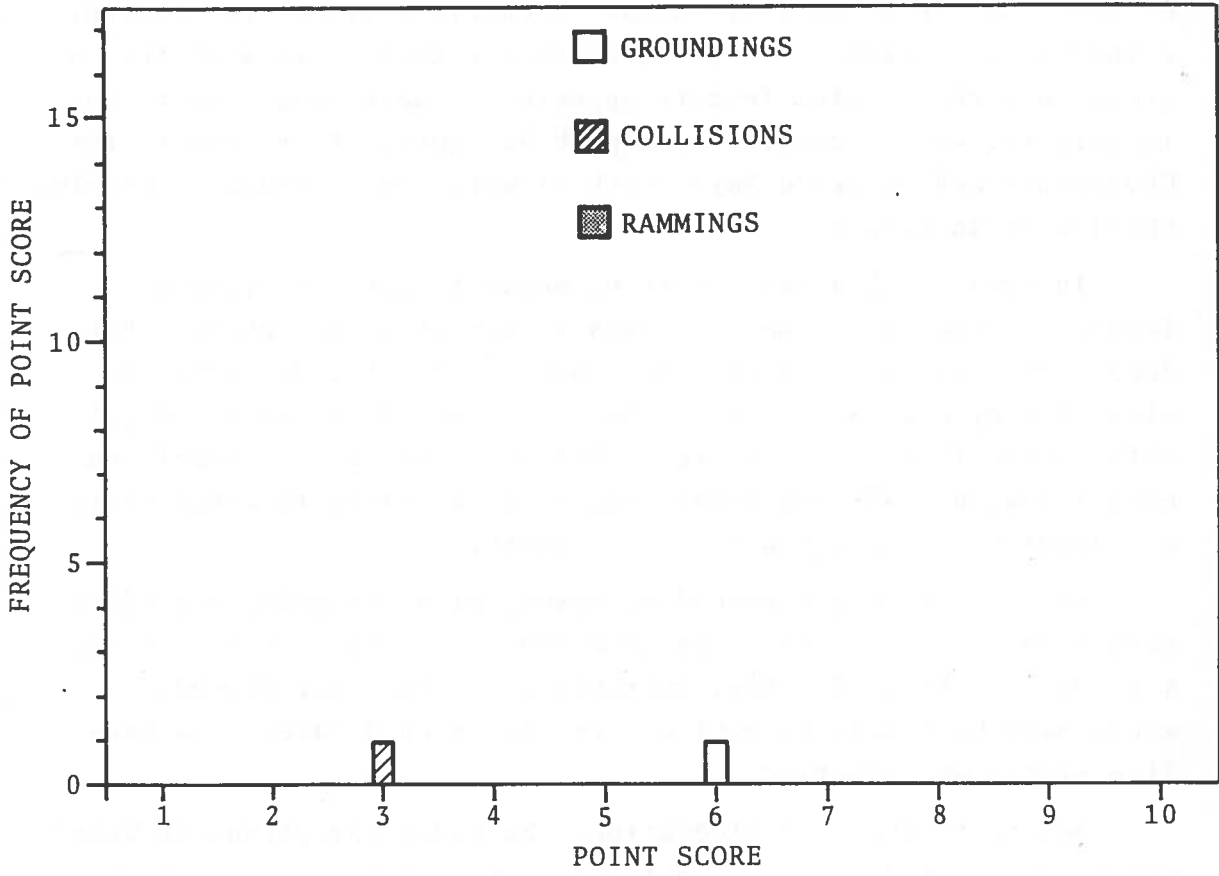

I.2.3 CHARTING OF RESTRICTED ZONES

One suggestion that appeared to have merit at the beginning of the study is to indicate areas on charts that are off limits, either to all vessels, or to deep draft vessels. In 8 of the 55 groundings this system feature appeared to have some effect, but in only two was it considered a probable cure. Four were in the Chesapeake and Delaware Bays, both of which have gradually varying shallow ocean floors.

In areas of gradually varying ocean floors, charting of forbidden zones has a major drawback when it is recognized that deep-draft vessels come in a continuum of drafts, depending on size, shape, and cargo load. Thus a 30-foot draft vessel might safely pass through large areas that a 40-foot draft vessel could not; likewise a 40-foot vessel might safely navigate areas where a 50-foot vessel could not; and so forth.

In 5 of the eight grounding cases, pilot transfer procedures were involved; i.e., the ship grounded while awaiting or meeting a pilot. In these 5 cases, improved pilot transfer procedures would have been more effective. In the other 3 cases, the base-line system was superior.

Adding to these considerations the tidal variations in water depth, restricted zones did not appear to offer much help beyond the printed depths on the charts.

The probability of prevention was estimated at 6% for groundings 4% overall, and the SPI was 4.

It is therefore concluded that the added stimulus of clearly demarcated restricted zones on the charts will not appreciably reduce groundings.

OPERATIONAL FEATURE 3: CHARTING OF RESTRICTED ZONES

(1) SCORING SUMMARY

POINT SCORE/NO. OF CASES:

- GROUNDINGS 31/8
- COLLISIONS 0/0
- RAMMINGS 0/0

Nature of Casualty	No. of Cases	% of Cases	Prob. of Prev.	Spec. Prev. Index
Groundings (55)	8	15%	6%	3.8
Collisions (17)	0	0	0	-
Rammings (6)	0	0	0	-
Overall Rating	8	15%	4%	3.8

(2) SPECIFIC ISSUES

Location: Guayanilla Bay - G-18, 24, 27, 55
Delaware Bay - G-1, 4, 44
Chesapeake Bay - G-23

(3) HISTOGRAM OF SCORES

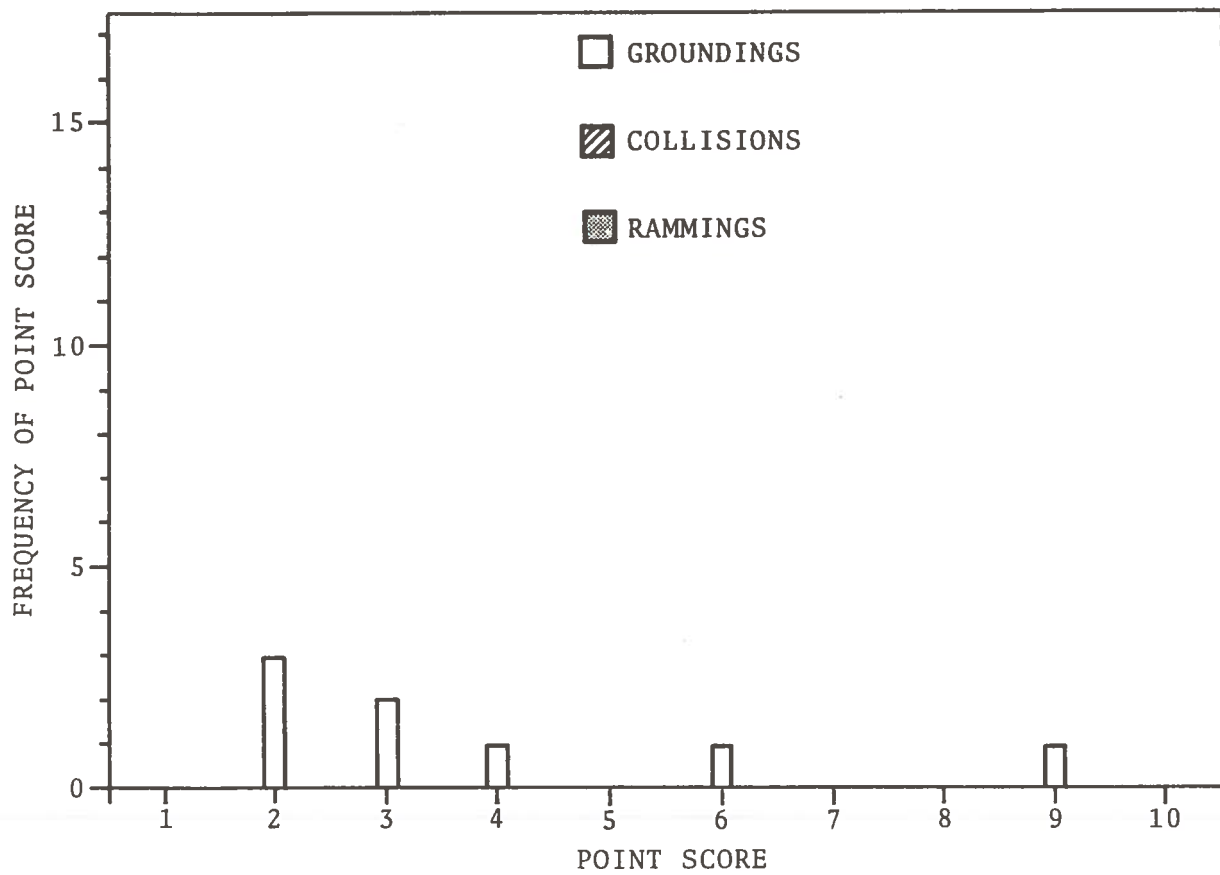

I.2.4 NEW TRAFFIC SEPARATION SCHEMES

Traffic separation schemes have been in operation for several years at the approaches to New York Harbor, Delaware Bay, Portland, Boston, Chesapeake Bay, Los Angeles/Long Beach, San Francisco, in the Santa Barbara Channel, and recently in the Straits of Juan de Fuca. Of the 16 collisions, only one occurred in a traffic land, and that was a crossing situation where the crossing vessel was burdened, and failed to give way.

Five collisions were determined to be preventable by traffic separation schemes. Two of them took place in the Straits of Juan de Fuca, prior to the establishment of a traffic separation scheme. Two collisions took place in fairways in the Gulf of Mexico. One took place in a narrow passage in Long Island Sound.

There were two groundings were modifications to the traffic separation schemes might have been of some value, both occurring in Delaware Bay. In one case, a deep draft vessel in-bound from Five Fathom Bank grounded in the precautionary area. This type of problem (see I.2.3) is a good reason for routing loaded tanker traffic through the southern traffic routes approaching Delaware Bay. The other grounded while awaiting a pilot. (Modifications to the traffic separation schemes are closely tied in with pilot transfer areas; the problem is discussed in I.2.6 and 5.2.10).

The nature of the fairway collisions suggests that fairways pose hazards of their own--they were both end-on situations. In one case one vessel was streaming to the left of the fairway; in the other, one vessel, a shallow draft, was also on the left, passing parallel to a channel in the fairway. This suggests that vessels should not travel in the left half of the fairway, except in overtaking situations.

The collision in Long Island Sound was at Barker Point, where a narrow passageway exists, apparently less than 1000 feet wide. From the chart it is not apparant why the westward-bound barge could not have passed well to the right of Gangway Rock without

great delay. Situations like this should be explored to see if one-way traffic limitations through such passageways could be imposed.

In summary, the data suggest that the existing traffic separation schemes are beneficial, but that new traffic separation schemes are not required. However, improvements in the use of traffic lanes and fairways should be explored. Some suggested measures are discussed in Section 5.2.8.

OPERATIONAL FEATURE 4: NEW TRAFFIC SEPARATION SCHFMES

(1) SCORING SUMMARY

POINT SCORE/NO. OF CASES:

- GROUNDINGS 8/2
- COLLISIONS 36/4
- RAMMINGS 0/0

Nature of Casualty	No. of Cases	% of Cases	Prob. of Prev.	Spec. Prev. Index
Groundings (55)	2	4%	1%	4
Collisions (17)	4	24%	21%	9
Rammings (6)	0	0	0	-
Overall Rating	6	8%	6%	7.3

(2) SPECIFIC ISSUES

Juan de Fuca - Two collisions occurred in the Straits of Juan de Fuca prior to the establishment of a traffic separation scheme there.

Collisions in a Traffic Lane - One: crossing situation.

(3) HISTOGRAM OF SCORES

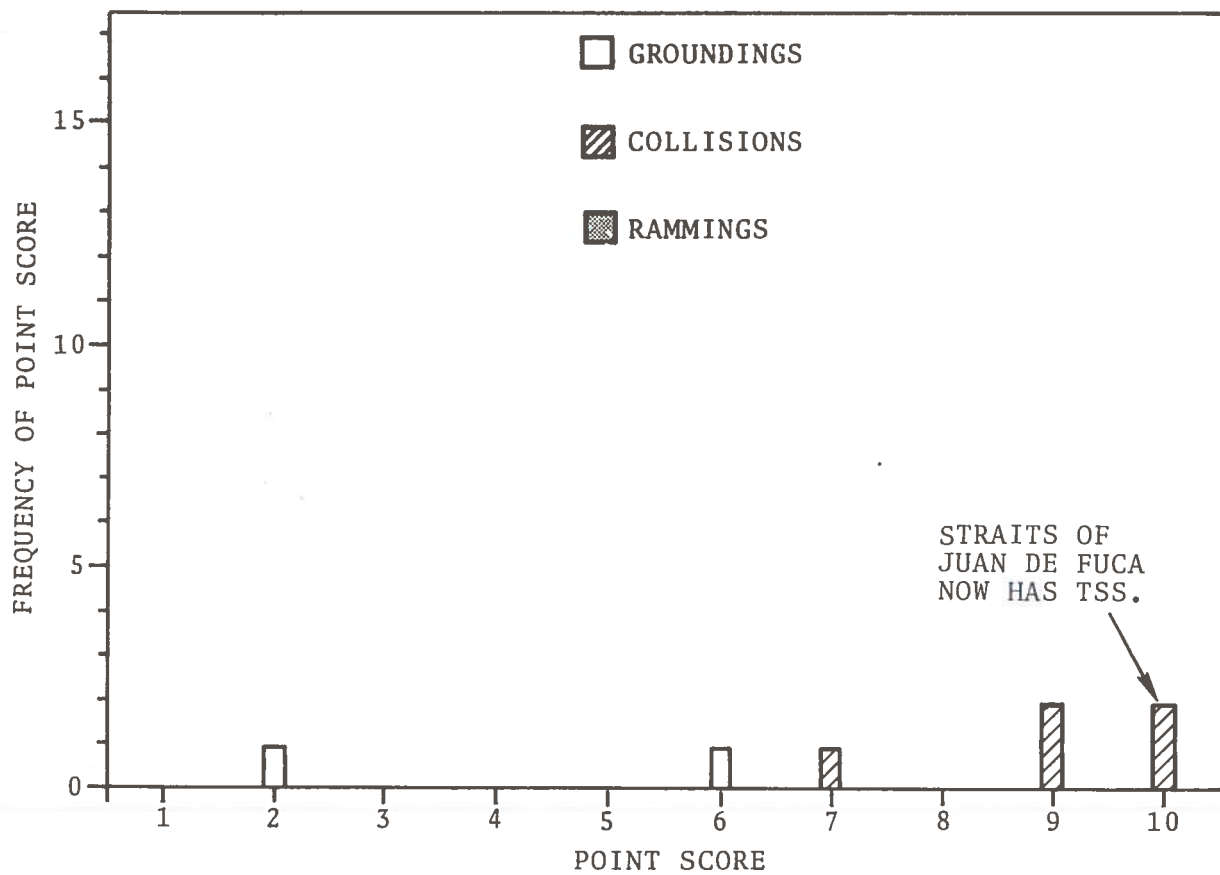

I.2.5 IMPROVED LIGHT/BUOY TECHNIQUES

In 19 of the 55 groundings, buoy detection, confusion over buoy identification and location, and lack of buoys contributed to the casualties. Of these, 14 were at night, 2 at twilight, and 2 were in reduced visibility (0.1 miles and 0.5 miles, respectively) during the day; only one occurred during conditions of good day-time visibility. In three cases, buoys were incorrectly identified; in each of these the mistake was understandable, because another buoy with the same visual characteristics was located nearby. In three cases, the buoys were located quite close to the shoals from which they were providing protection: the margins may have been too small for deep draft vessels. In 10 cases, the existence of additional buoys near shoals would have helped.

With better buoy identification, the addition of lights in the case of buoys marking dangerous shoals, moving buoys to accommodate deep draft vessels,* and more frequent buoy monitoring in areas of frequent tanker traffic and severe weather,** 10 casualties would have been prevented at the 80% level (SPI=8): i.e., where these actions might have helped, they would have been very effective.

More buoys might have helped in nine other cases; buoys might have helped if they had been placed in deeper water at shoal areas (for added safety of deep draft vessels), marking the outside of traffic lanes, and to mark fairway boundaries and intersections. The SPI for these cases was only four. It is even more significant that baseline system, which incorporates a good navigation unit aboard, had higher scores in all but one of these cases. Thus, it is concluded that additional buoys, while helpful, are not essential.

This operational feature is incorporated into the Improved Aids-to-Navigation System (see Section 5.2.9).

*It is recognized that steep shoals may not permit placement of a buoy in an optimum location for the deep draft vessels.

**Buoy monitoring is a large and costly part of the Coast Guard workload, therefore those areas which have continuing problems of buoy dislocations may need to be examined for means of improving buoy auditing practices.

OPERATIONAL FEATURE 5: IMPROVED LIGHT/BUOY TECHNIQUES

(1) SCORING SUMMARY

POINT SCORE/NO. OF CASES:

- GROUNDINGS 113/19
- COLLISIONS 0/0
- RAMMINGS 0/0

Nature of Casualty	No. of Cases	% of Cases	Prob. of Prev.	Spec. Prev. Index
Groundings (55)	19	35%	21%	5.9
Collisions (17)	0	0	0	-
Rammings (6)	0	0	0	-
Overall Rating	19	24%	14%	5.9

(2) SPECIFIC ISSUES

Buoy ID: G-3, 36, 46
 Add Light: G-39
 Add Buoys: G-1, 6, 18, 23, 28, 35, 37, 42, 43, 44
 Move Buoys: G-7, 11, 53
 Monitor Buoy
 Locations: G-17, 26

If additional buoys are eliminated, the scores are changed:

GROUNDINGS	10	18%	12%	8.0
OVERALL	10	13%	9%	8.0

(3) HISTOGRAM OF SCORES

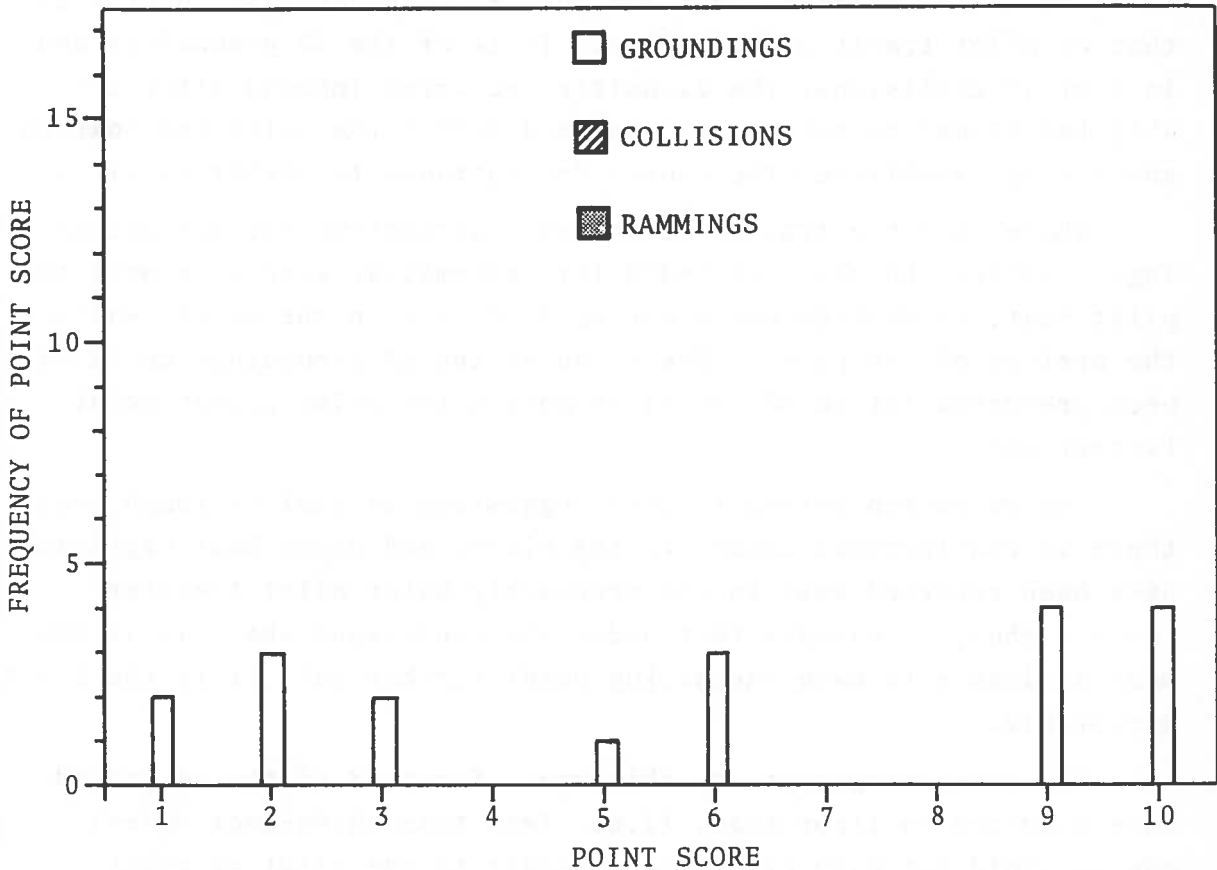

(4) DISCUSSION

In the evaluation process, the question was frequently posed, "if a buoy had been located nearby, would the accident have been prevented?". The 10 cases where the answer was affirmative are open to dispute, since there is no guiding principle other than "if it happened here once, it could happen again." That is, in the case of additional buoys, the guidelines are unclear. On the other hand, for buoy identification, addition of a light, buoy relocation, and monitoring of buoy locations, reasonable guidelines can be offered. Eliminating the cases where additional buoys were considered leaves nine cases, and a total point score of 74; this gives a specific prevention index of eight. Of the nine cases, seven were given "highly likely" scores of 9 or 10. It is therefore concluded that this operational feature is still significant.

I.2.6 IMPROVED PILOT TRANSFER PROCEDURES

One of the problems that emerged from the casualty reports is that of pilot transfer operations. In 14 of the 55 groundings and in 3 of 17 collisions, the casualties occurred inbound after the ship had slowed to take on a pilot and before the pilot had boarded and safely established the course for entrance to harbor or river.

There were two typical situations, accounting for all groundings: either the ship proceeded into unfamiliar waters to meet the pilot boat, or drifted while moving dead slow in the water awaiting the arrival of the pilot. Every one of the 14 groundings could have been prevented (at an SPI of 9) by moving the pilot pickup point further out.

The objection raised to this suggestion is that in rough seas there is considerable danger to the pilot, and pilot boat capsizings have been reported even in the presumably safer pilot transfer zones; thus, it appears that under the conditions where it is the most desirable to have the pickup point further out, it is the least acceptable.

The counterarguments to this are: first, 8 of the 14 groundings occurred in light seas, (i.e., less than three-foot waves) and so would not have presented a danger to the pilot or pilot boat (the other six took place in moderate seas, three to six-foot waves); second, there is no fundamental reason why the pilot boat cannot act as escort to loaded tankers, especially in moderately rough seas.

Two collisions occurred in limited visibility while awaiting a pilot. In each case an assigned waiting station could have helped. Such a system feature will become more feasible when LORAN-C is required on ships; this will assure their separation -- the relative, or rendezvous, accuracy of LORAN-C is about 300 feet or better (i.e., two receivers placed at the same point will agree to within about 300 feet).

Another alternative is to arrange for a more timely arrival of the pilot at the vessel, thus reducing the waiting time and the likelihood of the vessel drifting into a shoal while waiting for the pilot.

Of the 17 cases involving pilot transfer, 11 occurred in two areas: Delaware Bay (4), and Guayanilla Bay, Puerto Rico (7); of the others two occurred in Chesapeake Bay, one off Savannah, Georgia, and one outside San Juan Harbor. Thus, there are two "hot spots" where special attention needs to be focused - Delaware and Guayanilla Bays.

Thirteen of the 17 cases occurred at night or in reduced visibility, emphasizing the need for improved radar and lighting cues -- Delaware, Guayanilla, and Chesapeake Bays, where there is lack of radar coastline definition and good targets.

The probability of prevention of this operational feature is estimated to be 22% for groundings, 18% overall, and the specific prevention index is 8. Pilot transfer is definitely an area where significant improvements can be effected. This operational feature is incorporated into the vessel passport system of Section 5.2.2, as a separate system in Section 5.2.10, and in the recommended actions of Section 7.4.5.

OPERATIONAL FEATURE 6: IMPROVED PILOT TRANSFER PROCEDURES

(1) SCORING SUMMARY

POINT SCORE/NO. OF CASES:

- GROUNDINGS 120/14
- COLLISIONS 19/3
- RAMMINGS 0/0

Nature of Casualty	No. of Cases	% of Cases	Prob. of Prev.	Spec. Prev. Index
Groundings (55)	14	25%	22%	8.6
Collisions (17)	3	18%	11%	6.3
Rammings (6)	0	0	0	-
Overall Rating	17	22%	18%	8.2

(2) SPECIFIC ISSUES

Location:

- Delaware Bay - Groundings: G-1, 36, 38, 53
- Cheasapeake Bay - Collisions: C-14
- Groundings: G-4
- Guayanilla Bay - Groundings: G-7, 14, 18, 24, 31, 50, 55
- Other - Collisions: C-3, 4
- Groundings: G-13, 51

Inbound: All; Outbound: - None

Weather/Sea State:

- 0-3 ft: G-4, 14, 18, 38, 50, 51, 53, 55
- 3-6 ft: G-1, 7, 13, 24, 31, 36
- > 6 ft: None

Visibility, Groundings:

- Daytime, more than 5 miles: G-1, 38, 50
- Night, more than 5 miles: G-7, 13, 14, 18, 24, 31, 36, 55
- Daytime, less than 5 miles: G-4, 51
- Night, less than 5 miles: G-53

Visibility, Collisions:

- Daytime, more than 5 miles: C-14
- Daytime, less than 1 mile: C-3, 4

Cases where pilot pickup point further out would have helped:

Collisions: C-14

Groundings: G-1, 4, 7, 13, 14, 18, 24, 31, 36, 38, 50,
51, 53, 55

Cases involving close anchoring positions:

Collisions: C-3, 4

(3) HISTOGRAM OF SCORES

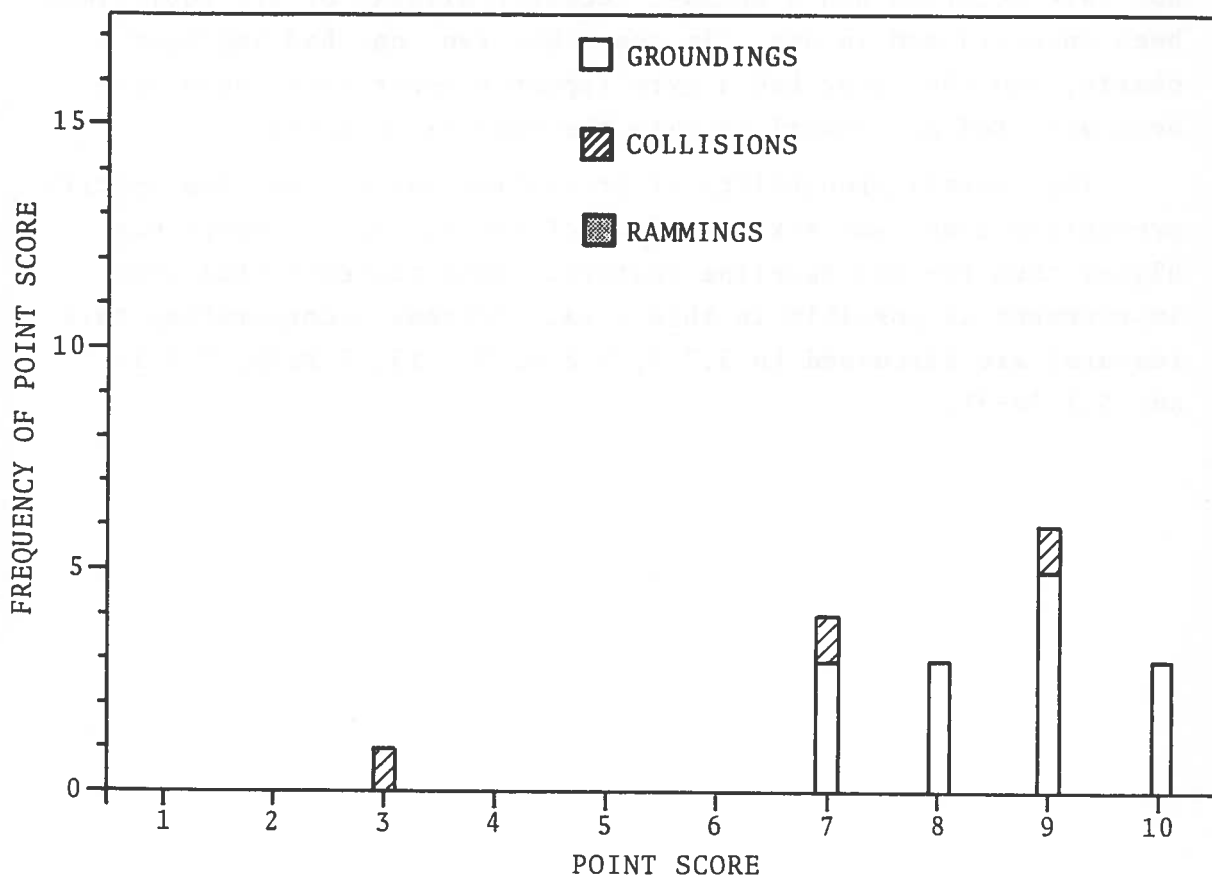

I.2.7 IMPROVED EQUIPMENT STANDARDS

In one collision and 6 of 55 groundings, lack of functioning navigation equipment or proper charts played a prominent role in the casualty, and figured in two others. In every case, human errors compounded the problem: lack of cross-checking between instruments, traveling too fast through dense fog, and taking unnecessary risks. Of the eight groundings, six would probably not have occurred had a LORAN-C receiver/display or its equivalent been on-board and in use. In the other two, one had improper charts, and the other had a gyro repeater error that could have been detected by comparison with the magnetic compass.

The overall probability of prevention was 8%, and the specific prevention index was six. In four of the cases, the score was higher than for the baseline feature. This suggests that some improvement is possible in this area. Systems incorporating this features are discussed in 5.2.2, 5.2.3, 5.2.10, 5.2.15, 5.2.16 and 5.3.26-31.

OPERATIONAL FEATURE 7: IMPROVED EQUIPMENT STANDARDS

(1) SCORING SUMMARY

POINT SCORE/NO. OF CASES:

- GROUNDINGS 52/8
- COLLISIONS 9/1
- RAMMINGS 0/0

Nature of Casualty	No. of Cases	% of Cases	Prob. of Prev.	Spec. Prev. Index
Groundings (55)	8	15%	9%	6.5
Collisions (17)	1	6%	5%	9
Rammings (6)	0	0	0	-
Overall Rating	9	12%	8%	6.8

(2) SPECIFIC ISSUES

Casualties where LORAN-C display obtained a score of 6 or more:
G-2, 20, 21, 23, 35, 37

Casualty where improper charts were on board: G-7

Casualty where gyro repeater was in error: G-42

Casualties where radar was out and requirement for two radars would have helped: G-21, 37; C-3

*These belong in Baseline System.

(3) HISTOGRAM OF SCORES

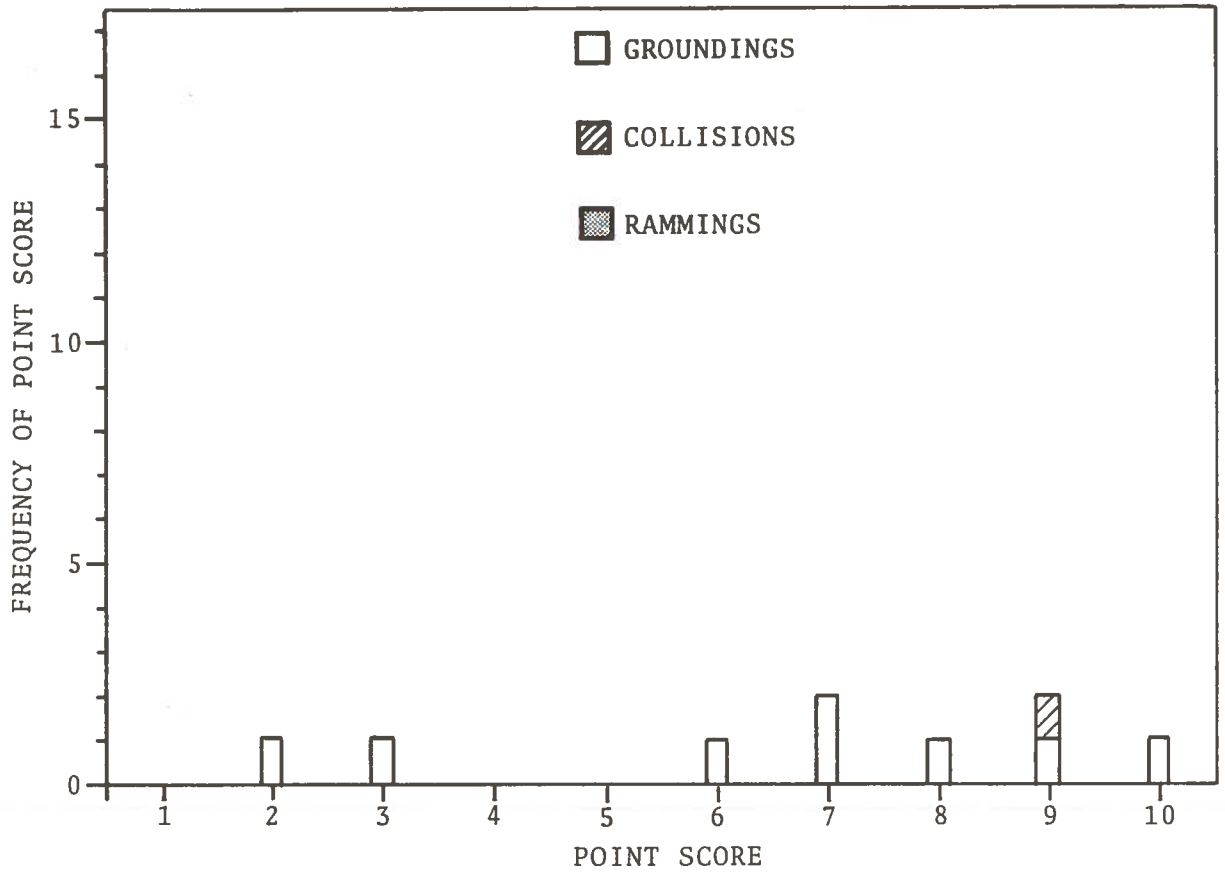

I.2.8 INCENTIVE TO REPAIR MALFUNCTIONING GEAR

This operational feature was intended to give a measure of the effectiveness of strong sanctions against leaving port without having functioning gear aboard. Making such an assessment is complicated by the fact that in the six cases involving malfunctioning equipment, it was difficult to determine whether it was operating when the ship left port. In one case it was highly likely that the ship left the Bahamas with malfunctioning gear, because it grounded in Florida with both radars and depth sounder inoperative. In another case, the sudden loss of a radar at a critical moment caused a lack of navigation cues. The other cases were ambiguous.

In only two cases was it determined that strong measures would have prevented the grounding. In both of these cases the requirement of navigation gear like LORAN-C would be as effective as this feature.

The probability of prevention is estimated at 3%, and the SPI at 4.

Thus, stronger incentives do not appear to offer any promise of significantly affecting collisions, rammings or groundings. The present incentive to maintain the safety of the ship appears to be adequate. A more promising way to deal with equipment outages is by special shore-based attention to such vessels (see Section 5.3.3).

OPERATIONAL FEATURE 8: INCENTIVE REPAIR MALFUNCTIONING GEAR

(1) SCORING SUMMARY

POINT SCORE/NO. OF CASES:

- GROUNDINGS 23/6
- COLLISIONS 0/0
- RAMMINGS 0/0

Nature of Casualty	No. of Cases	% of Cases	Prob. of Prev.	Spec. Prev. Index
Groundings (55)	6	11%	4%	4
Collisions (17)	0	0	0	-
Rammings (6)	0	0	0	-
Overall Rating	6	8%	3%	4

(2) SPECIFIC ISSUES

None

(3) HISTOGRAM OF SCORES

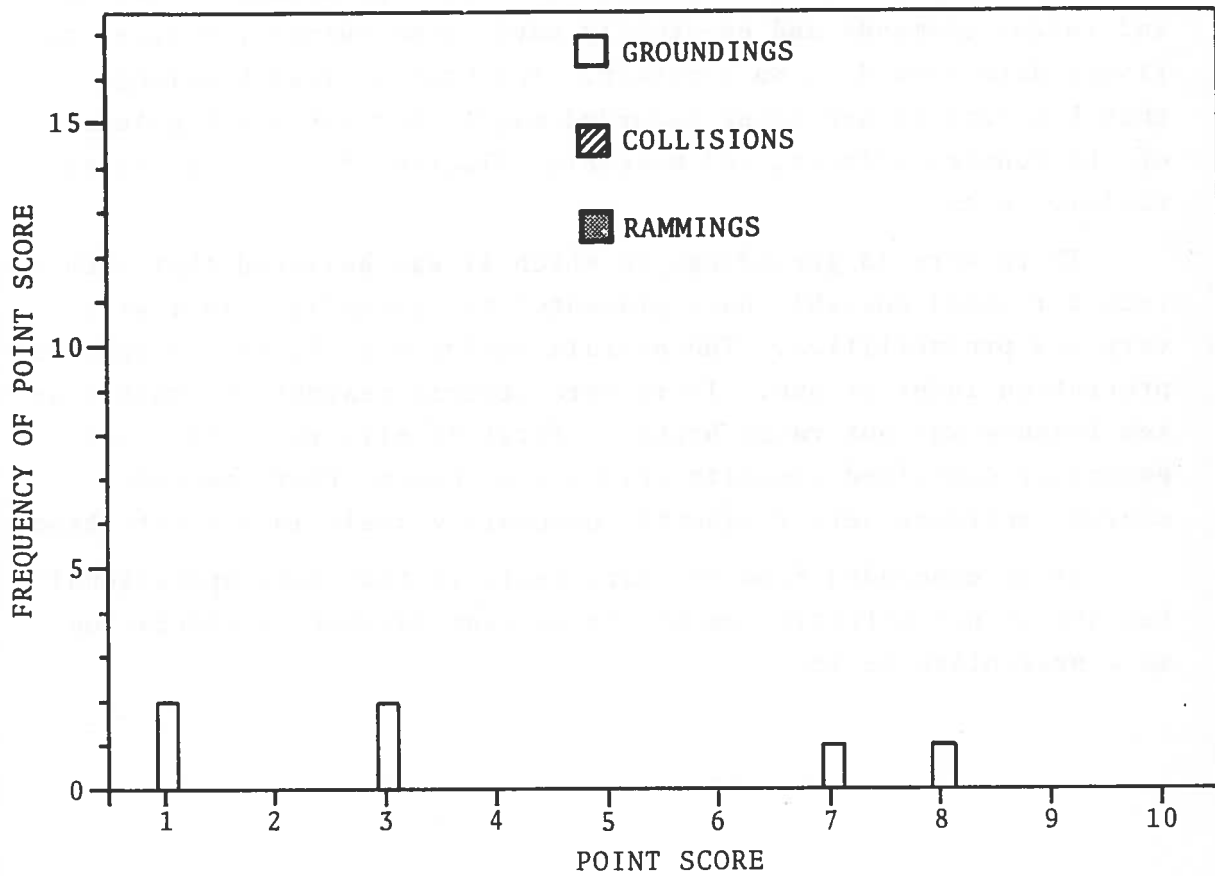

I.2.9 MANDATORY COURSE RECORDER

Mandatory course recorders would record gyrocompass readings and rudder commands and eventually navigation outputs, similar to flight data recorders on aircraft. The hope is that knowledge that his actions are being recorded might increase the vigilance of the conning officer, and make him reluctant to cut corners or violate rules.

There were 13 groundings in which it was believed that such a recorder could possibly have prevented the grounding, most with very low probabilities. The overall rating was 2%, with a specific prevention index of one. There were several reasons why this system feature was not rated highly: first of all, the ship's log generally contained adequate evidence of human error; second, course recorders were frequently on-board vessels in the data base.

It is concluded from the data analyzed that this operational feature is not effective enough to warrant further consideration as a preventive device.

OPERATIONAL FEATURE 9: MANDATORY COURSE RECORDER

(1) SCORING SUMMARY

POINT SCORE/NO. OF CASES:

- GROUNDINGS 19/13
- COLLISIONS 0/0
- RAMMINGS 0/0

Nature of Casualty	No. of Cases	% of Cases	Prob. of Prev.	Spec. Prev. Index
Groundings (55)	13	24%	3%	1.4
Collisions (17)	0	0	0	-
Rammings (6)	0	0	0	-
Overall Rating	13	17%	2%	1.4

(2) SPECIFIC ISSUES

None

(3) HISTOGRAM OF SCORES

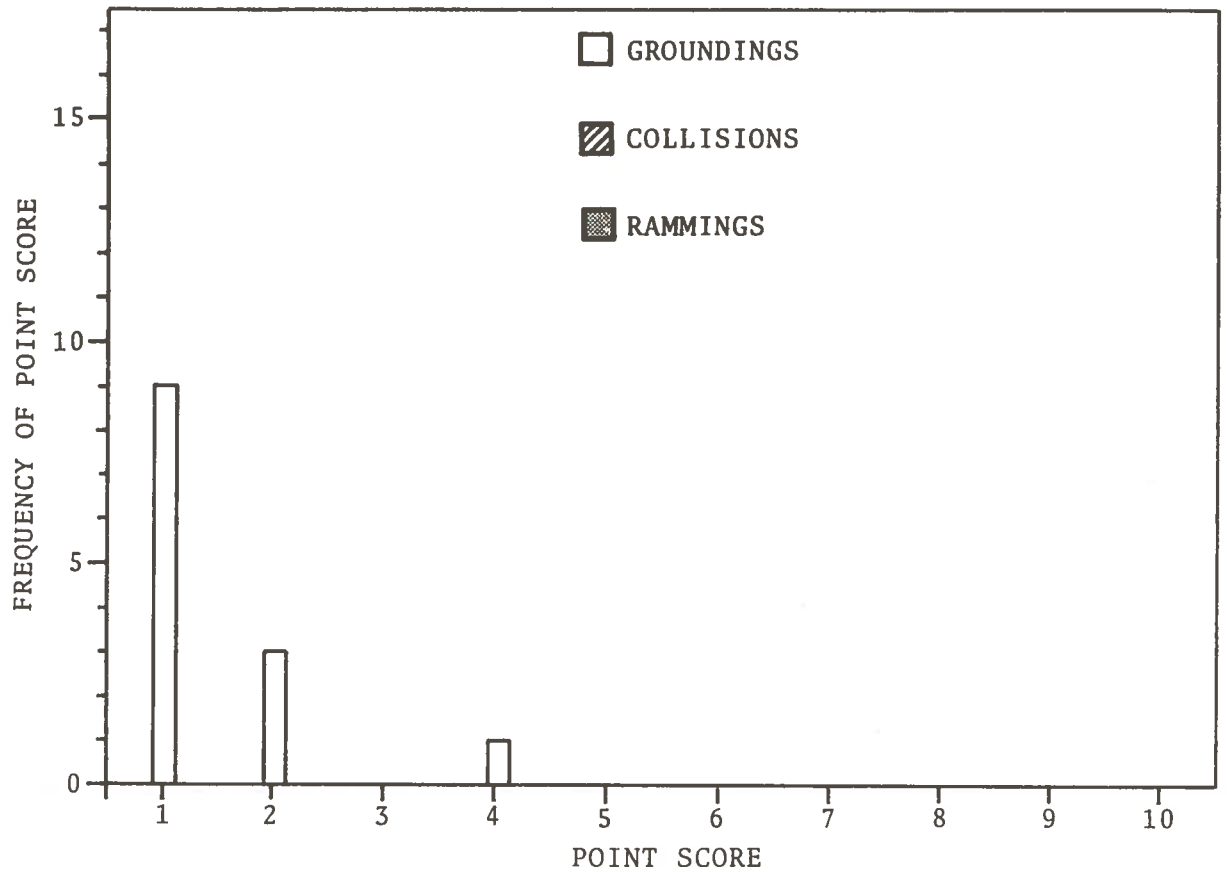

I.2.10 IMPROVED POSITION ACCURACY OVER LORAN-C

Navigation is now performed largely with celestial fixes, radar fixes using either recognizable shore landmarks or lights (or sometimes buoys), and navigation gear when it is available. Ship positions relative to channel buoys can be accurately determined to within a few feet with radar, and visually to 100-200 feet by using lights as references. Celestial fixes are generally good to within five miles if taken by an expert mariner, while LORAN-C generally gives 1/4 mile accuracy even fairly close to shore. The question naturally arises as to whether better accuracy than this is needed to prevent groundings and rammings.

In the analysis, in only four out of 55 groundings was accuracy considered a factor, and in only two cases was it estimated that a perfectly accurate navigation receiver would have a better than 20% chance of preventing the groundings.* In the particular case where it appeared likely to offer some help, it was the peculiar situation of a vessel rendering assistance to a burning ship, where the rescuing vessel was attempting to come as close as possible to the vessel in distress to minimize the distance that the unmotored lifeboat would have to row.

Thus, precise accuracy was not a factor in most casualties in the data base. This system feature achieved an overall prevention probability of only 3% for groundings, and a specific effectiveness index of four.

*Groundings in narrow channels were not included in the data base. The conclusions stated here apply in the offshore area outside these channels.

OPERATIONAL FEATURE 10: IMPROVED POSITION ACCURACY OVER LORAN-C

(1) SCORING SUMMARY

POINT SCORE/NO. OF CASES:

- GROUNDINGS 15/4
- COLLISIONS 0/0
- RAMMINGS 0/0

Nature of Casualty	No. of Cases	% of Cases	Prob. of Prev.	Spec. Prev. Index
Groundings (55)	4	7%	3%	3.8
Collisions (17)	0	0	0	-
Rammings (6)	0	0	0	-
Overall Rating	4	5%	2%	3.8

(2) SPECIFIC ISSUES

None

(3) HISTOGRAM OF SCORES

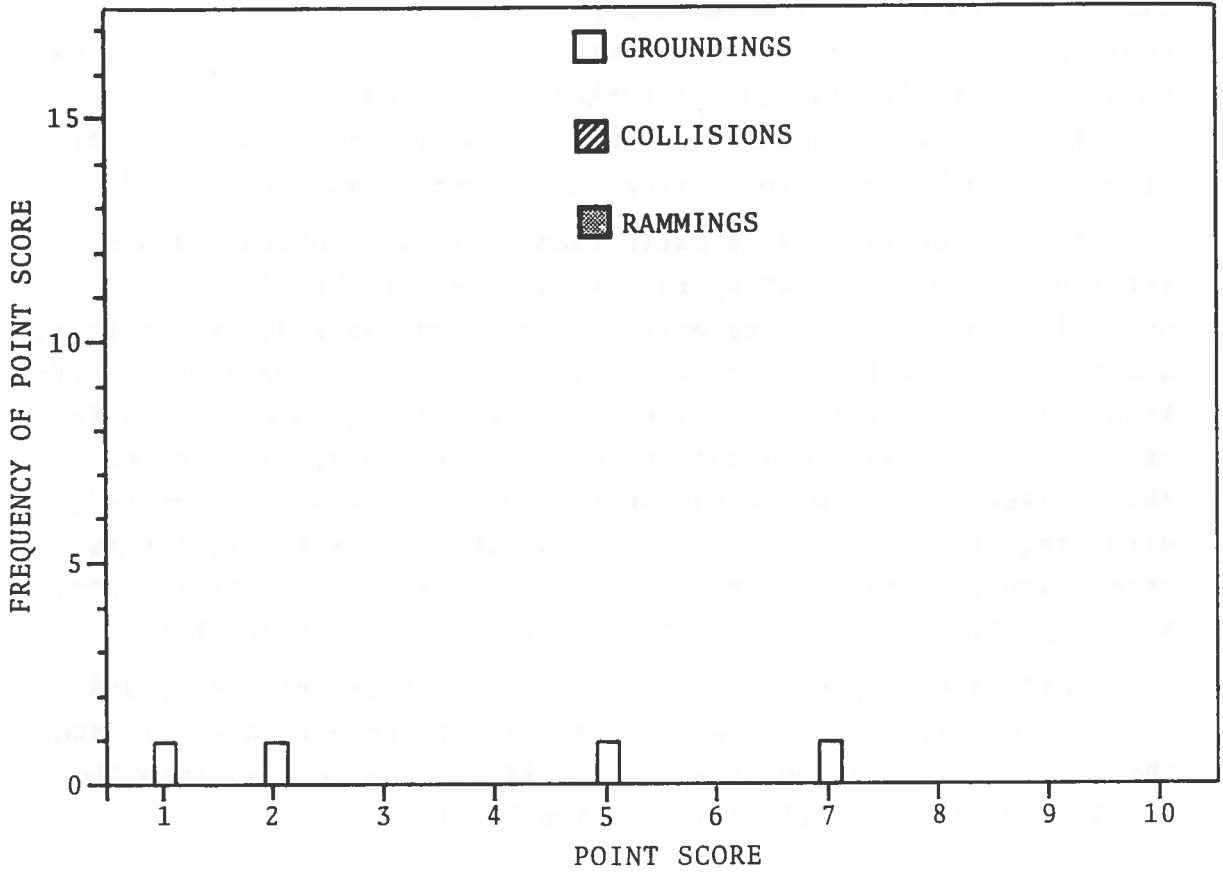

I.2.11 ABILITY TO OBTAIN A DEPENDABLE POSITION FIX

There were 14 cases identified where it was believed that the capability to reliably determine position to 1/4-mile accuracy would have helped to avoid the casualty. In every case, there was no position fixing instrument (other than celestial) on board, except for radar. In all 14 cases, the additional redundancy provided by another position-fixing instrument would have helped.

The use of radar as a navigation tool has problems, demonstrated by the contributing factors in nine of the 14 cases: in one collision, the conning officer was using the radar to navigate, and failed to plot a vessel course; clutter problems made it difficult to take bearings in five cases, resulting in errors in four of those; the radar was out in three other cases. In each of these cases, a backup navigation instrument like a LORAN or radio direction-finder would have been invaluable. Similarly, for two other cases, where the gyro or gyro repeater had an offset error, a backup navigation instrument would have been very helpful.

This factor appeared in one collision, three rammings, and ten groundings; the overall probability of prevention is 11% and the specific prevention index, six. It is incorporated into the Baseline System, described in Section 5.2.1.

OPERATIONAL FEATURE 11: ABILITY TO OBTAIN A DEPENDABLE POSITION FIX

(1) SCORING SUMMARY

POINT SCORE/NO. OF CASES:

- GROUNDINGS 57/10
- COLLISIONS 3/1
- RAMMINGS 25/3

Nature of Casualty	No. of Cases	% of Cases	Prob. of Prev.	Spec. Prev. Index
Groundings (55)	10	18%	10%	5.7
Collisions (17)	1	17%	2%	3
Rammings (6)	3	50%	42%	8.3
Overall Rating	14	18%	11%	6.1

(2) SPECIFIC ISSUES

Collision, using radar for navigation: C-14

Navigation Redundancy would have helped: All Cases

Radar Position - fixing error: R-2, 5; G-2, 27, 43

Radar Clutter Problem: R-2; G-2, 27, 43

Radar Outage: G-20, 21, 37

Gyro Error: G-42, 44

(3) HISTOGRAM OF SCORES

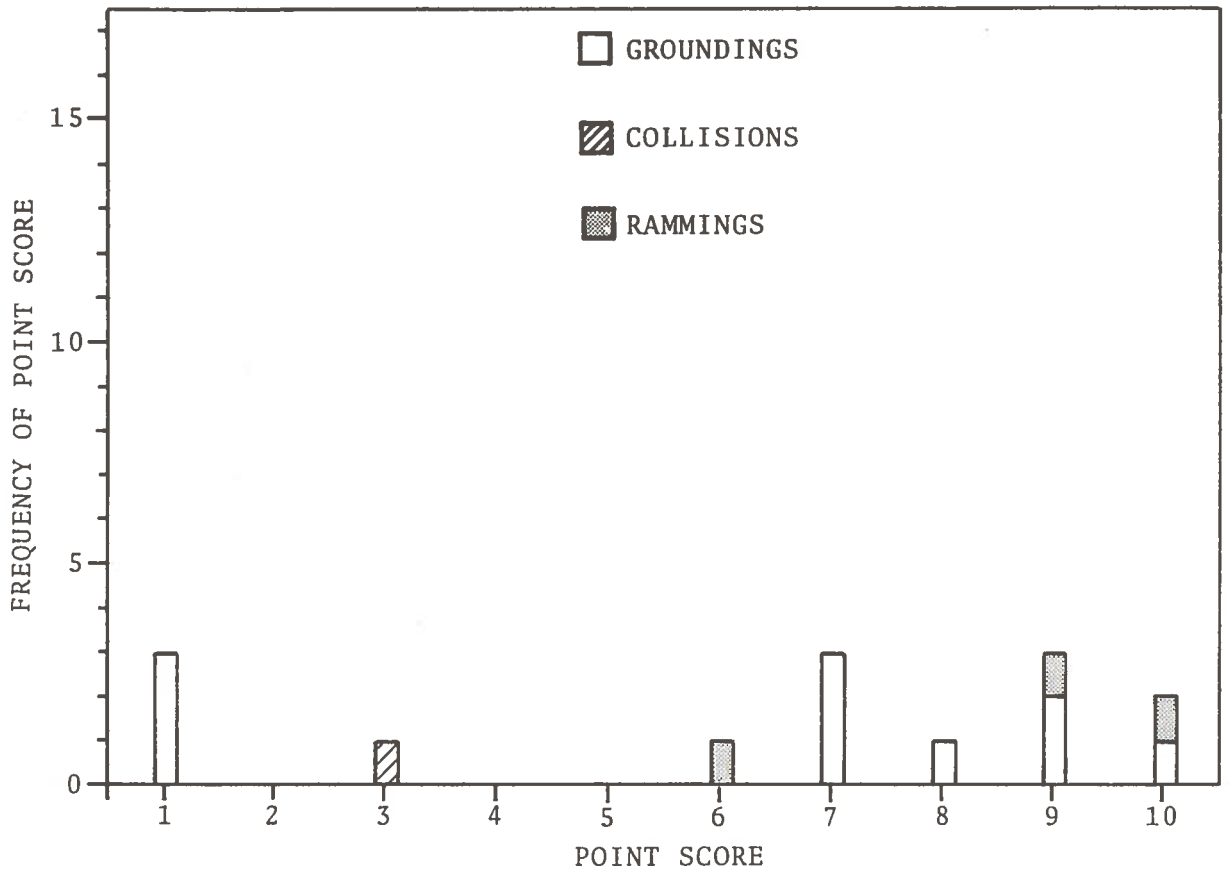

I.2.12 DISPLAY OF NAVIGATION DATA

Older LORAN receivers require a considerable amount of tuning, and making choices between auxiliary stations. Direction-finding likewise requires some effort in selecting stations, finding the transmitter locations on charts, and plotting bearings. Radar fixes require establishing ranges (or range and bearing plus compass corrections) to fixed landmarks or buoys. In each case, several minutes of effort are required to set up the instruments, and chart the results. The effort required precludes their frequent usage.

There are presently on the market LORAN-C receivers which automatically acquire and track the signals from the LORAN-C chains, and display two time measurements. These measurements can be manually plotted on the appropriate chart to fix position accurately -- official charts have the LORAN-C grid lines.

Satellite receivers using the military TRANSIT satellite give similar accuracy (0.1 to 0.25 NM). They are better for open ocean usage because the satellites provide almost global coverage; however, for coastal usage a transit satellite receiver is not adequate by itself because the satellite coverage has periods of non-availability of one to two hours. The fixes obtained by this means are used to update and correct dead-reckoning or Omega methods to estimate position, but cannot be used in close quarters to avoid shoals.

Assuming that measured positions are available on a continuous basis (continuous here means at least once every minute or so), the relative ease of usage of equipment providing a display of time coordinates (or latitude/longitude) over similar equipment requiring manipulation and timing was found to be significant in 24 groundings. By "significant" it is meant that the score assigned to the "display" system feature under consideration here exceeded the "availability" operational feature considered in I.2.11 by at least two points; i.e., the probability of prevention for that casualty was deemed to be 20% higher or more.

In nine cases, undue reliance on buoys to determine position caused an incorrect assessment of position, which would have been avoided with a reliable navigation instrument.

Twenty-one of the 24 casualties (87%) took place either at night, twilight, or in reduced visibility; this compares with 80% in the entire data base of 78 casualties.

In sum, this system feature would have been helpful in 38 cases (33 out of 55 groundings, four out of six rammings, and one out of 17 collisions). The overall probability of prevention is 26%, and the specific prevention index (SPI) is five. Ignoring cases occurring in Puerto Rico and the Virgin Islands where LORAN-C coverage is not planned reduces the number of groundings to 24, the overall probability of prevention to 22%, and increases the SPI slightly to six.

This operational feature is incorporated into the baseline system (Section 5.2.1) premised on the guidelines of the study (Section 3.3) and the rules of shipboard equipment requirements presently being proposed and considered. The baseline system is the system that is assumed will be in operation by the 1985/1990 time frame.

OPERATIONAL FEATURE 12: DISPLAY OF NAVIGATION DATA

(1) SCORING SUMMARY

POINT SCORE/NO. OF CASES:

- GROUNDINGS 174/33(139/24)*
- COLLISIONS 3/1
- RAMMINGS 27/4

Nature of Casualty	No. of Cases	% of Cases	Prob. of Prev.	Spec. Prev. Index
Groundings (55)	33	60%(44%)*	32%(25%)*	5.3(5.8)*
Collisions (17)	1	17%	2%	3
Rammings (6)	4	67%	45%	6.8
Overall Rating	38	49%(37%)*	26%(22%)*	5.4(5.8)*

(2) SPECIFIC ISSUES

- Visibility: Day, > 2 miles - G- 1, 10, 21, 29, 52
 Day, ≤ 2 miles - C-10; G-2, 20, 23, 37
 Night, < 2 miles - R-45, 6; G- 3, 6, 11, 17, 22, 24, 26, 31, 35, 36, 39, 42, 44, 45, 46, 47, 55
 Night, ≤ 2 miles - G-9, 27, 43, 53
 Twilight, > 2 miles - G- 8, 18, 28
 i.e., 87% in reduced visibility or Nite/Twilight compared to 80% overall.

Undue Reliance On Buoys: G- 8, 10, 23, 26, 29, 36, 39, 46, 47

Ease of Usage a Key Factor: G- 1, 2, 3, 8, 9, 10, 17, 18, 22, 23, (2 Pt spread over "Availability") 24, 26, 28, 29, 31, 35, 36, 42, 45, 46, 47, 52, 53, 55

Location:

- Puerto Rico - G- 18, 24, 26, 27, 31, 39, 45, 55
- Virgin Islands - G- 42
- Hawaii - None

*Excluding casualties in Puerto Rico and the Virgin Islands.

(3) HISTOGRAM OF SCORES

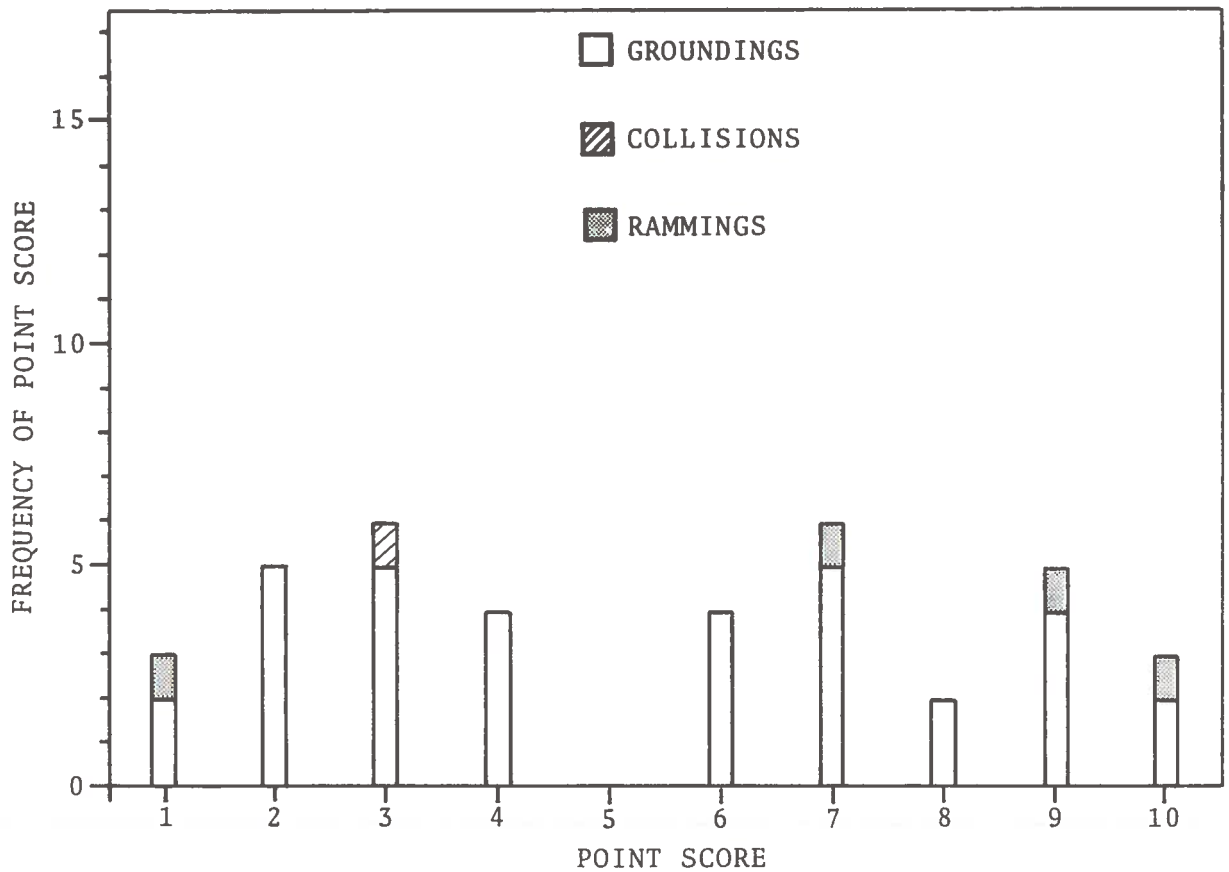

(4) DISCUSSION

Of the total number of groundings (55), 13 were in Puerto Rico, and three in the Virgin Islands. There is no plan to extend LORAN-C coverage into this area (see guidelines in Section 3.3). The question arises as to the availability of this operational feature and the effect on the conclusions. On this feature, the absence of coverage in those areas involves a total of nine cases and 35 points; this reduces the number of cases from 33 to 24, the point score from 174 to 139, the % of cases from 60% to 44%, the probability of prevention from 33% to 25%, while the specific prevention index is increased from 5.3 to 5.8.

The specific prevention index for those 9 particular cases was 3.9, meaning that the system feature would be somewhat less effective there.

I.2.13 DISPLAY OF DEVIATION FROM INTENDED TRACK

This system feature is an extension of the previous one, "Display of Navigation Data". In order to obtain this capability, it is necessary to have continuous navigation information. It requires the navigator to plan at least a segment of the voyage in advance. While in theory the intended track could be any track on the surface of the ocean, it will usually take the form of a series of waypoints connected by great-circle or rhumb-line tracks. By entering, via keyboard, a series of LORAN-C time coordinates* representing points where maneuvers are expected to be performed, a processor can calculate the distance of the ship, via the electronic navigation unit, from the intended track. This feature has an important advantage over a display of navigation data: it is not necessary to walk to the chart and plot the position in order to know the deviation from intended course - it is continuously displayed.

This feature would have helped significantly in four rammings and 34 groundings, two more than the display feature. Of these, in one ramming and six groundings there was believed to be a slight advantage to be gained from a display of deviation-from-track, rather than just a display of position; in one other ramming and in six other groundings, the deviation-from-track display was considered to be significantly better (two point spread or more).

The overall ratings for this system feature are: The feature would have helped in 67% of the rammings and 62% of the groundings; the probabilities of prevention are about 18% for rammings, 35% for groundings, and 29% overall. The specific prevention index was six, a high figure.

*Since charted LORAN-C lines are corrected to incorporate long-term propagation effects, latitude/longitude coordinates should be avoided near the coast, because the coordinate conversion algorithms do not usually account for the corrections.

OPERATIONAL FEATURE 13: DISPLAY OF DEVIATION FROM INTENDED TRACK

(1) SCORING SUMMARY

POINT SCORE/NO. OF CASES:

- GROUNDINGS 195/35
- COLLISIONS 3/1
- RAMMINGS 30/4

Nature of Casualty	No. of Cases	% of Cases	Prob. of Prev.	Spec. Prev. Index
Groundings (55)	34	62%	35%	5.6
Collisions (17)	1	6%	2%	3
Rammings (6)	4	67%	18%	7.5
Overall Rating	39	50%	29%	5.8

(2) SPECIFIC ISSUES

Slight (1 pt) Advantage Over Display: R-4; G-11, 17, 21, 35, 42, 46

Significant (\geq 2 pt) Advantage over Display: R-6; G-3, 29, 41, 42, 53, 54

(3) HISTOGRAM OF SCORES

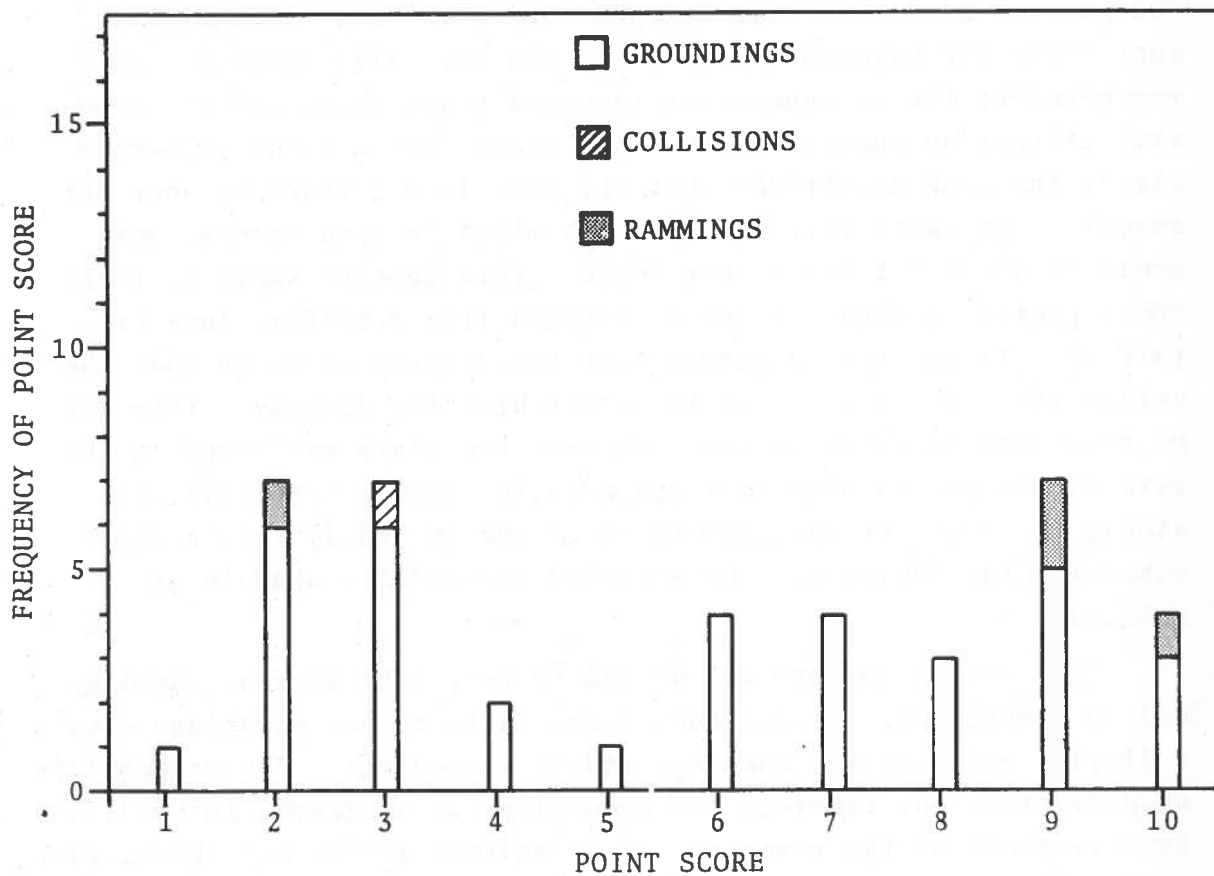

I.2.14 ALERT INDICATING EXCESSIVE DEVIATION FROM TRACK

This system feature is an extension of the previous one, "Display of Deviation from Intended Track". Here the navigator must enter the waypoints as before, and must also enter a number representing the distance-from-intended-track which, if exceeded, will trigger an audible alarm. The alarm (not a warning) merely alerts the conning officer that the ship is off track by some set amount. Typically this would be 2-5 miles in open waters, but would be about 0.5 miles near shore. This feature would tell the conning officer when the vessel strayed from a traffic lane or fairway. It has the advantage over the display alone in that the bridge officers do not have to be watching the display - they may be attending to other duties. Because the alarm may sound in the case of unexpected maneuvers (such as to avoid a potential collision), it should be designed so as to not be unduly irritating - otherwise the device will be switched off and its usefulness reduced.

This system feature was deemed to be useful in four rammings and 36 groundings. It was considered to have some advantage over a display alone in two rammings and 16 groundings. The probability of prevention for rammings and groundings is estimated to be 42%, involving 65% of the rammings and groundings in the data base, with a specific prevention index of 6. The overall PP is estimated at 34%.

OPERATIONAL FEATURE 14: ALERT INDICATING EXCESSIVE DEVIATION FROM TRACK

(1) SCORING SUMMARY

POINT SCORE/NO. OF CASES:

- GROUNDINGS 226/36
- COLLISIONS 3/1
- RAMMINGS 33/4

Nature of Casualty	No. of Cases	% of Cases	Prob. of Prev.	Spec. Prev. Index
Groundings (55)	36	65%	41%	6.2
Collisions (17)	1	6%	2%	3
Rammings (6)	4	67%	55%	8.2
Overall Rating	41	53%	34%	6.4

(2) SPECIFIC ISSUES

Advantage over Display: R-4, 6; G-2, 3, 8, 10, 11, 25, 29, 35, 36, 39, 42, 44, 46, 47, 53, 54

(3) HISTOGRAM OF SCORES.

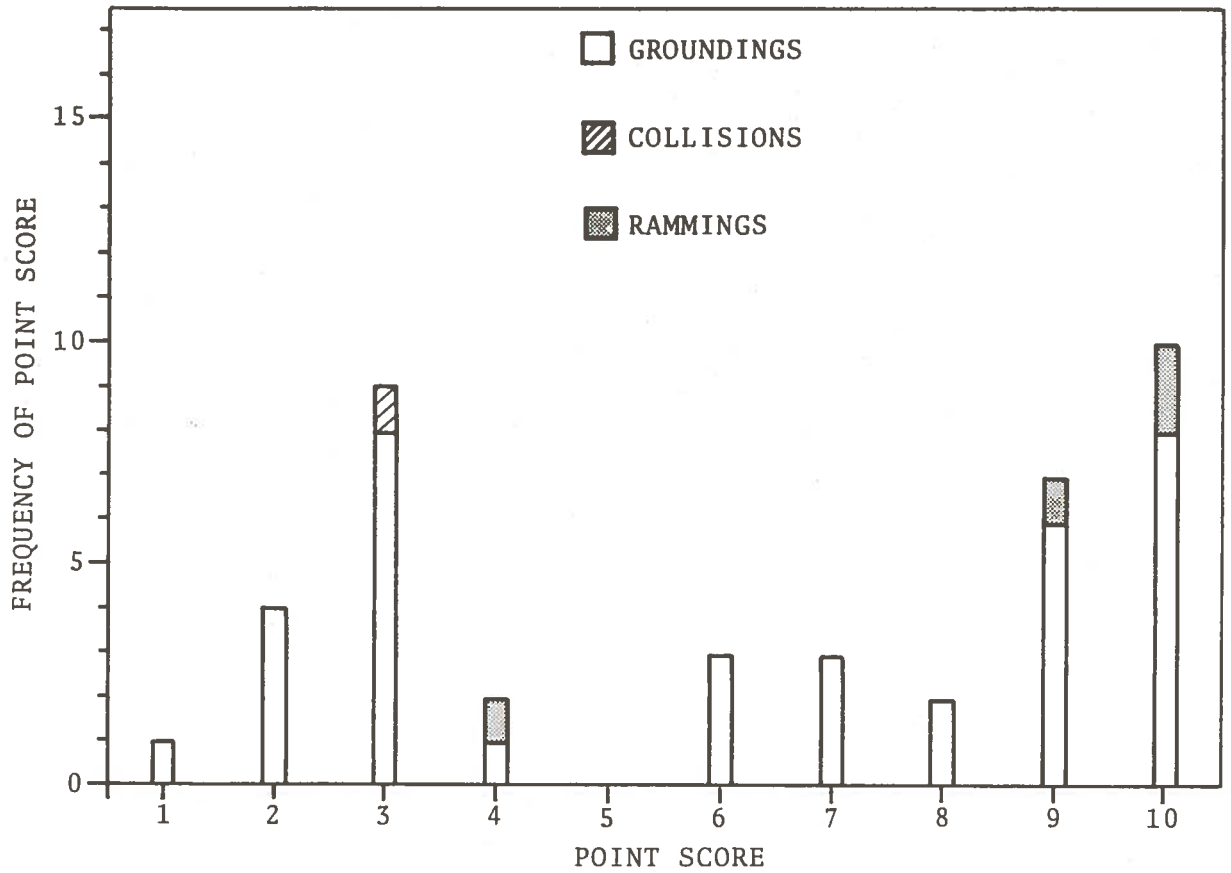

I.2.15 MANEUVERING POINT ALERT

A maneuvering point alert is an extension of the display of deviation-from-track discussed in Section I.2.13. Quite simply, once the navigator has entered waypoints, there is nothing further needed than to engage the alert. Approximately five minutes before a waypoint is reached, a gentle bell rings, notifying the conning officer that it is time to change course. The primary reason for including this as a system feature was to provide for cases where the ship might inadvertently proceed beyond a reasonable course change point and go aground.

In only one ramming and seven groundings was it believed that this operational feature would have helped; in only four of these eight cases did the addition of the feature to the deviation display of Section I.2.13 improve the probability of prevention.

Nonetheless, the feature is so inexpensive to include that it should be considered. In the case of the Globtik Sun, for example, which rammed an oil platform, losing seven men and causing a major oil spill, the ship had just passed a bend in the fairway. Look-outs on the bridges were unaware of the platform, and the conning officer apparently failed to maneuver the turn. This operational feature would have been invaluable in alerting the conning officer had he plotted a course up the fairway. In two other cases the vessel proceeded further into shore than she intended.

The overall probability of prevention was estimated at 5%, with a specific prevention index of five, over and above the performance of the deviation display feature of Section I.2.13.

OPERATIONAL FEATURE 15: MANEUVERING POINT ALERT

(1) SCORING SUMMARY

POINT SCORE/NO. OF CASES:

- GROUNDINGS 29/7
- COLLISIONS 0/0
- RAMMINGS 10/1

Nature of Casualty	No. of Cases	% of Cases	Prob. of Prev.	Spec. Prev. Index
Groundings (55)	7	13%	5%	4.1
Collisions (17)	0	0	0	-
Rammings (6)	1	17%	17%	10
Overall Rating	8	10%	5%	4.9

(2) SPECIFIC ISSUES

Turn in Fairway: R-6 (Globtik Sun); G-6
 Too close to shore in poor visibility - G-20 (passenger vessel)

More points than Deviation Alert - G-6, 18, 52

Drift Alert - Awaiting Pilot - G-18

Did not get to maneuvering point - G-36, 46, 52

(3) HISTOGRAM OF SCORES

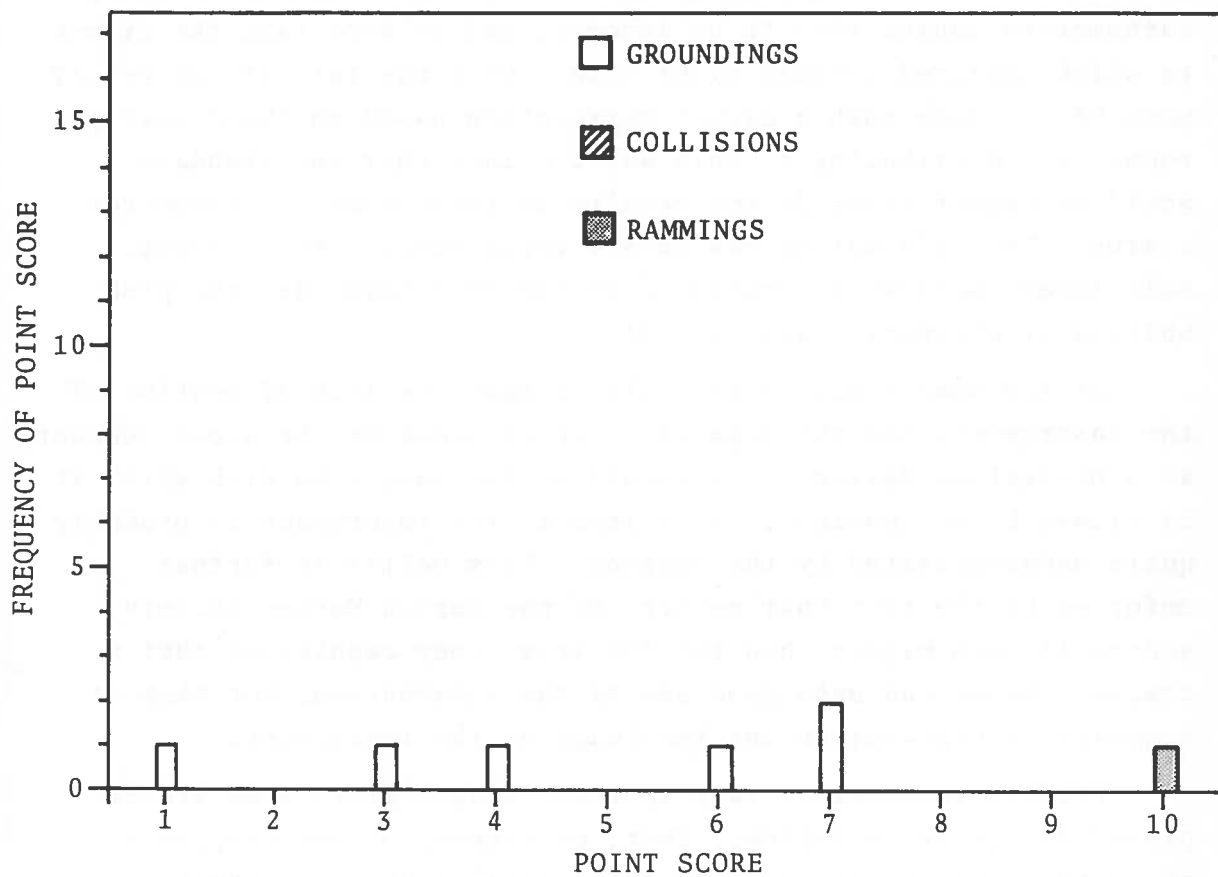

I.2.16 IMPROVED DEPTH DETECTION

The operational feature of improved depth detection was included in order to determine whether the difficulties in using fathometers caused them to be ignored, and to ascertain the extent to which improved methods might help. Unfortunately it was rarely possible to make such a direct correlation based on the casualty reports. Contributing to this was the fact that the standard accident report forms do not require an indication of fathometer status. The information was rarely volunteered. As a result, only three cases were identified by the OVTM team, and the probability of prevention was only 2%.

At the same time, it is believed that the lack of mention of the instrument, and the apparent lack of usage of the depth sounder as a navigation device, is a result of the suspicion with which it is viewed by the mariner. As a result, its importance is probably quite underestimated by the scoring. This belief is further enforced by the fact that members of the Boston Marine Society scored it much higher than the TSC team; they emphasized that a trained seaman can make good use of the information, but that it requires interpretation and knowledge of the instrument.

Present fathometers vary in their readability; some are displayed digitally in fathoms, feet, or meters; others display a rotating light of varying intensity; still others use chart recorders, which provide a helpful history of soundings and show the contour of the ocean floor just traversed. False alarm and confusion can be caused by water turbulence, engine noise, sharks, and schools of fish (one of the chief uses of depth sounders is the location of fish). Sound waves penetrate mud and sand to some degree; thus it is sometimes difficult to ascertain the location of the bottom, particularly where the floor consists of a rocky bottom covered by a layer of mud. Another problem is caused by the location of the instrument: it is frequently placed in the chartroom, aft of the wheelhouse, or in some other location not easily accessible for constant monitoring. Recent bridge designs incorporate multiple digital readouts on the wings - a good practice.

With most large vessels there are usually two officers on the bridge, while small tankers and tugs may only have one; this further emphasizes the need for accessibility.

The need for improved depth detection was not considered to be obvious enough to be incorporated into a system recommendation. However, in order for the alert features described in Sections I.2.17-I.2.19 to work properly, better depth-sounding techniques will be required.

OPERATIONAL FEATURE 16: IMPROVED DEPTH DETECTION

(1) SCORING SUMMARY

POINT SCORE/NO. OF CASES:

- GROUNDINGS 9/3
- COLLISIONS 0/0
- RAMMINGS 0/0

Nature of Casualty	No. of Cases	% of Cases	Prob. of Prev.	Spec. Prev. Index
Groundings (55)	3	5%	2%	3.0
Collisions (17)	0	0	0	-
Rammings (6)	0	0	0	-
Overall Rating	3	4%	1%	3.0

(2) SPECIFIC ISSUES

None

(3) HISTOGRAM OF SCORES

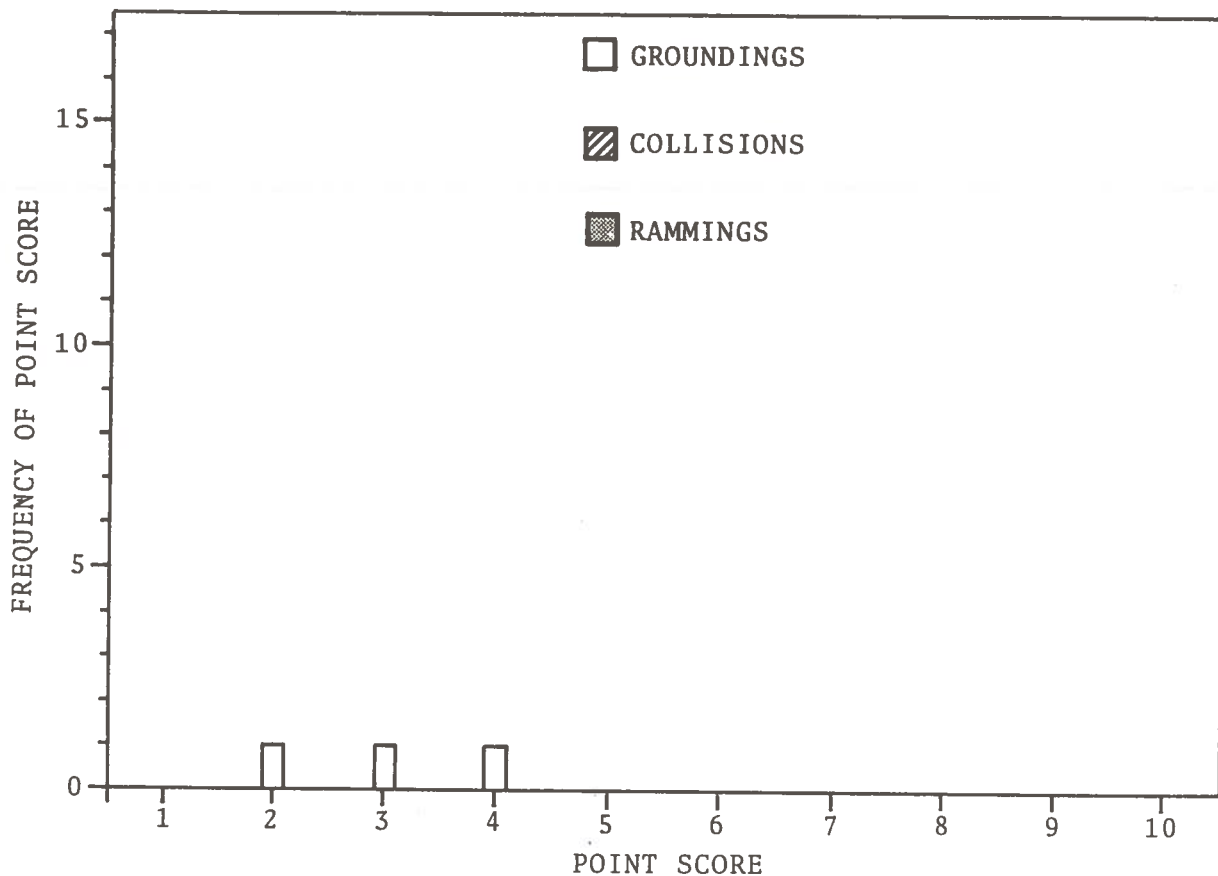

I.2.17 ALERT INDICATING SHALLOW DEPTH

The operational feature described here would enable a watchstander to select a depth that would result in an audible alert if the ship passed into waters shallower than that depth. Set at 50 fathoms, it could be used to indicate the Continental Shelf. In areas where banks are abrupt, it could be used for indicating proximity to reefs. Its chief potential for preventing groundings, however, is in shallow gentle sloping areas like the approaches to Delaware and Chesapeake Bays, and in the Gulf of Mexico. By setting a depth alert at about half the displacement below the hull or some appropriate figure determined from the charted depths, an alert would be helpful in calling the watchstander's attention to the fact that the vessel is in shallower water than he expected. He would not have to constantly monitor the instrument in order to benefit from it.

The design of such a system is discussed in Section 5.2.13.

A depth alert was judged to be potentially helpful in about 30 groundings at an SPI of 4. In 10 of these, there was considered to be more than a 50% chance that such a device would have been used and the accident avoided. The lower scores occurred in cases where general bridge discipline was so loose that it was not considered likely that the watchstander would have bothered to set the depth alert in the first place. The probability of prevention is estimated to be 24% for groundings. It has no direct applications to collisions and rammings.

OPERATIONAL FEATURE 17: ALERT INDICATING SHALLOW DEPTH

(1) SCORING SUMMARY

POINT SCORE/NO. OF CASES:

- GROUNDINGS 132/30
- COLLISIONS 0/0
- RAMMINGS 0/0

Nature of Casualty	No. of Cases	% of Cases	Prob. of Prev.	Spec. Prev. Index
Groundings (55)	30	55%	24%	4.4
Collisions (17)	0	0	0	-
Rammings (6)	0	0	0	-
Overall Rating	30	38%	17%	4.4

(2) SPECIFIC ISSUES

None

(3) HISTOGRAM OF SCORES

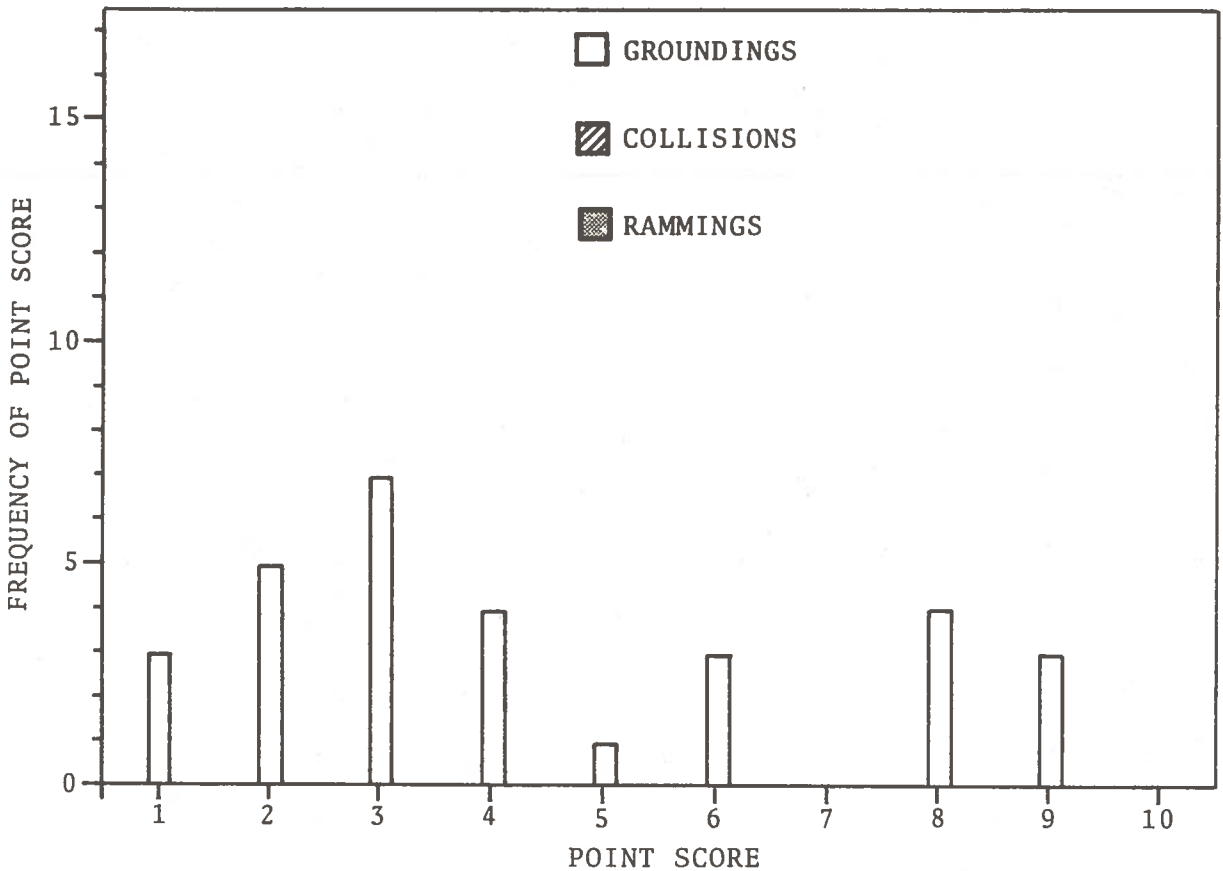

I.2.18 FORWARD-LOOKING SOUNDER

It is possible, in principle, to direct an acoustic transmission forward of the ship and detect echoes off of wrecks, obstructions, and banks. An alert could be given if any strong echoes are received within some selectable distance. For example, one mile would be a reasonable setting for large ships, while smaller, more maneuverable tankers or slower vessels like tug/barge combinations would use a shorter range. This operational feature was evaluated by examining charts at the accident locations, and ruling out areas where ocean floors were gradually sloped. High scores were given in cases where the banks were abrupt, where a distinguishable echo was likely to be obtained.

This feature was thought to be of potential benefit in 45, or 82%, of the groundings, with a specific prevention index of 7. The probability of prevention is estimated to be 55% for groundings.

The team estimates are probably on the optimistic side, because there was no measured data found that indicated clear limits on the practical possibilities of the technique. The design of such a system is discussed in Section 5.3.10.

OPERATIONAL FEATURE 18: FORWARD LOOKING SOUNDER

(1) SCORING SUMMARY

POINT SCORE/NO. OF CASES:

- GROUNDINGS 300/45
 - COLLISIONS 0/0
 - RAMMINGS 0/0

Nature of Casualty	No. of Cases	% of Cases	Prob. of Prev.	Spec. Prev. Index
Groundings (55)	45	82%	55%	6.7
Collisions (17)	0	0	0	-
Rammings (6)	0	0	0	-
Overall Rating	45	58%	38%	6.7

(2) SPECIFIC ISSUES

(3) HISTOGRAM OF SCORES

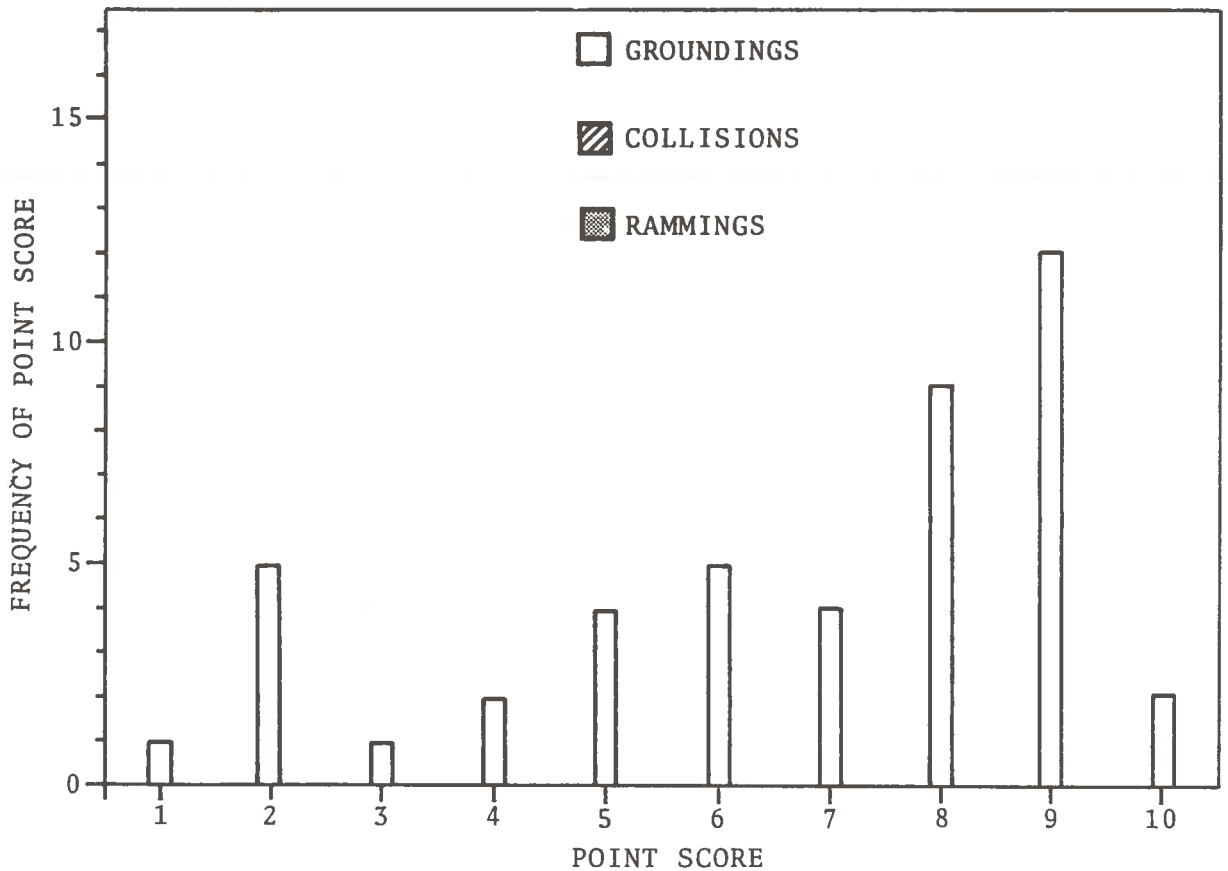

I.2.19 DEPTH MAPPING WITH ALERT

This operational feature was postulated on the assumption that it might be possible to receive echoes fore and abeam of the ship, and to map the depths of the ocean floor over a wide enough area to detect shoals, reefs, and shallow areas. The embodiment of such a capability is discussed in Section 5.2.14. As with the previous two features, conditions could be prescribed which would cause an alarm to sound. While this feature might seem far-fetched, equipment is available which performs similar tasks. The evaluation of the feature was premised on the assumption of a rather ideal device, unencumbered by practical considerations that might ultimately limit its usefulness.

The question of the timeliness of the information was sometimes difficult to judge. If a shallow rise or reef were detected about 0.5-1 miles ahead, and an alert sounded, the vesselmaster would require some time to assess the situation, and in many cases might be able only to reduce speed somewhat. Even that could reduce the prospects of a stranding, or reduce its seriousness.

The feature was considered to hold some potential benefit in 50 of 55 groundings at an SPI of 7, resulting in a probability of prevention estimate of 65% for groundings. If a device could be developed which reliably maps out depth contours, it would be of great value in avoiding groundings.

OPERATIONAL FEATURE 19: DEPTH MAPPING WITH ALERT

(1) SCORING SUMMARY

POINT SCORE/NO. OF CASES:

- GROUNDINGS 359/50
- COLLISIONS 0/0
- RAMMINGS 0/0

Nature of Casualty	No. of Cases	% of Cases	Prob. of Prev.	Spec. Prev. Index
Groundings (55)	50	91%	65%	7.2
Collisions (17)	0	0	0	-
Rammings (6)	0	0	0	-
Overall Rating	50	64%	46%	7.2

(2) SPECIFIC ISSUES

(3) HISTOGRAM OF SCORES

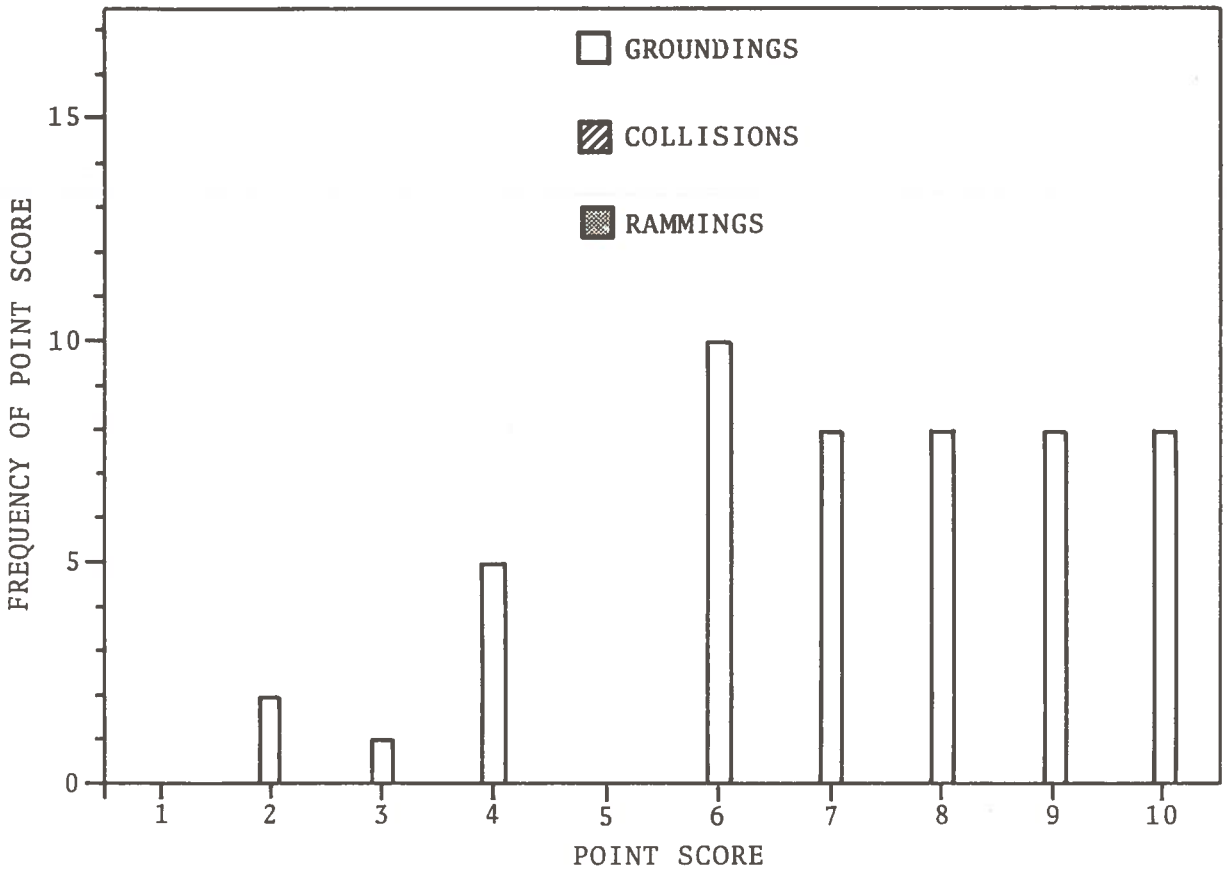

I.2.20 RACONS AT FAIRWAY, TRAFFIC LANE ENTRANCES

A RACON (RADar beaCON) is a transponder placed on a buoy, lighthouse, or other fixed aid-to-navigation (Henry, 1973). When a ship's radar transmits a pulse in the direction of the RACON, it triggers a coded response for the RACON. The watchstander at the radar will see a Morse figure (e.g., dash-dot-dot) painted prominently on the screen. The RACON location is approximately at the closest part of the symbol to the center of the sweep. There are 12 Morse figures which can be used (B,C,D,G,K,M,N,O,Q,X,Y,Z). There are presently about two dozen RACONS now in use in Alaska and the Great Lakes. There is only one RACON on the East Coast (Portland), three on the West Coast, and two in the Gulf. They are used extensively in Europe.

It was pointed out in Section I.2.5 that buoy identification was a problem in several casualties. If RACONS had been on the buoys in question, identification would have been easy. However, it is not practical to recommend RACONS on every major buoy: purchase and maintenance costs would be prohibitive, plus their usefulness would be reduced by confusion on radar screens caused by interference and proliferation of targets. Rather, when this system feature was evaluated, it was assumed that RACONS would be placed only at a few locations: near fairway intersections and entrances to traffic lanes, primarily, and with a few others judiciously placed to aid coastal and local vessel traffic.

RACONS meeting these conditions were deemed to be helpful in 2 rammings and 15 groundings, with a specific prevention index of 5 overall. In both of the 2 rammings and in 10 groundings, the RACON would have helped the mariner establish the buoy ID or the ship's initial entry position. The overall probability of prevention considering rammings and groundings is estimated at 14%, with an SPI of 5.

While it could not be factored into the assessment, the amount of concern evident in the casualty reports toward establishing buoy identity, the lack of cross-checking of instruments and cross-checking capability, and the fact that after days on the high

seas the approach to the coast represents a radical reorientation of attitude of the deck officers, suggest that the presence of an unambiguous, charted radar echo located out from shore would have a beneficial effect not adequately reflected in the casualty assessment. It can be used to calibrate navigation instruments, depth sounder, and radar, and provide the mariner with an added confidence to proceed. In the Gulf of Mexico this is particularly important, because of the numerous charted and uncharted oil platforms: when a vesselmaster is not certain he is in the fairway, he is less likely to be able to identify charted platforms positively, and to be sure that another platform is uncharted. Given a positive initial fix, however, such identification is much more reliable and simple.

OPERATIONAL FEATURE 20: RACONS AT FAIRWAY, TRAFFIC LANE ENTRANCES

(1) SCORING SUMMARY

POINT SCORE/NO. OF CASES:

- GROUNDINGS 70/15
- COLLISIONS 0/0
- RAMMINGS 14/2

Nature of Casualty	No. of Cases	% of Cases	Prob. of Prev.	Spec. Prev. Index
Groundings (55)	15	27%	13%	4.7
Collisions (17)	0	0	0	-
Rammings (6)	2	33%	23%	7
Overall Rating	17	22% (28%*)	11% (14%*)	4.9

*Groundings and rammings only.

(2) SPECIFIC ISSUES

Better initial position and buoy ID: R-5, 6; G-6, 17, 18, 23, 24, 31, 35, 36, 43, 47

Puerto Rico and Virgin Islands: G-18, 24, 31, 39, 42

(3) HISTOGRAM OF SCORES

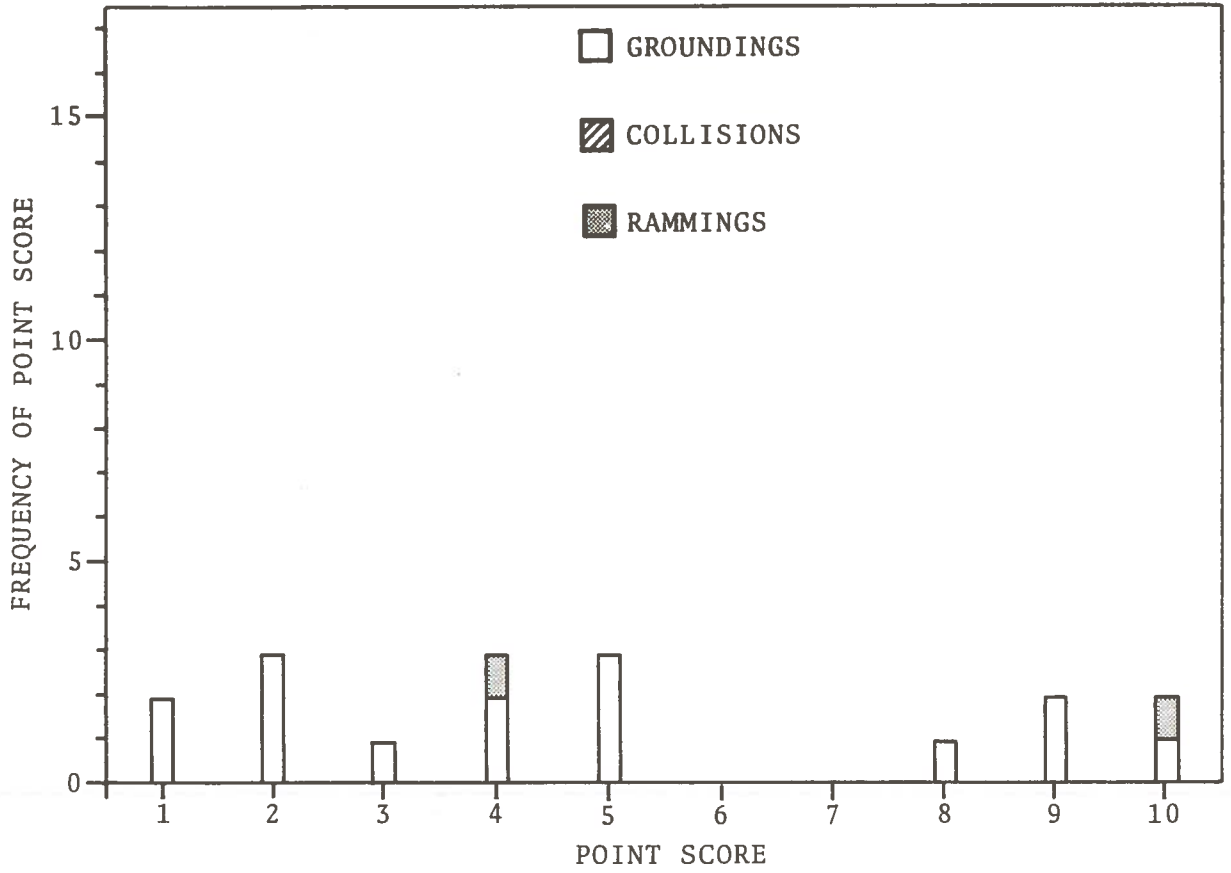

I.2.21 ABILITY TO OBTAIN DEPENDABLE, ALL-WEATHER RADAR RETURNS

This operational feature was included in order to get a measure of how frequently sea clutter, rain attenuation, and reflections caused confusion in the interpretation of radar data, contributing to an accident. Mariners are familiar with the problem of clutter: when winds cause white caps and choppy seas, the radar screen fills with clusters of small dots. If the gain adjustment is turned up, the clusters can merge into a continuous "whiteout", completely obscuring targets. As the gain is turned down, strong targets can be distinguished from clutter by virtue of the fact that they are larger, more intense, and don't vary from scan to scan the way clutter does. Small targets are difficult to find; as the gain is turned down further to reduce the clutter, these targets can disappear. Clutter is most severe at short ranges.

An interrogator/transponder system (see Section 5.2.18) gets around this problem by virtue of the fact that the equipped ships have transponders which reply at a slightly different frequency than the transmitted frequency. The receiver then receives the transponder reply with no clutter.

This feature was found to play a significant role in only two cases: one collision and one ramming. It would have been very effective (SPI=9.5) in those cases, however. The effectiveness for collisions and rammings was estimated to be 8%. By itself, the feature is not highly effective, but it is a valuable feature for equipment that incorporates several operational features.

OPERATIONAL FEATURE 21: ABILITY TO OBTAIN DEPENDABLE,
ALL-WEATHER RADAR RETURNS

(1) SCORING SUMMARY

POINT SCORE/NO. OF CASES:

- GROUNDINGS 0/0
- COLLISIONS 10/1
- RAMMINGS 9/1

Nature of Casualty	No. of Cases	% of Cases	Prob. of Prev.	Spec. Prev. Index
Groundings (55)	0	0	0	-
Collisions (17)	1	6%	6%	10
Rammings (6)	1	16%	15%	9
Overall Rating	2	2.2%(9%*)	2%(8%*)	9.5

*Collisions and Rammings Only

(2) SPECIFIC ISSUES

None

(3) HISTOGRAM OF SCORES

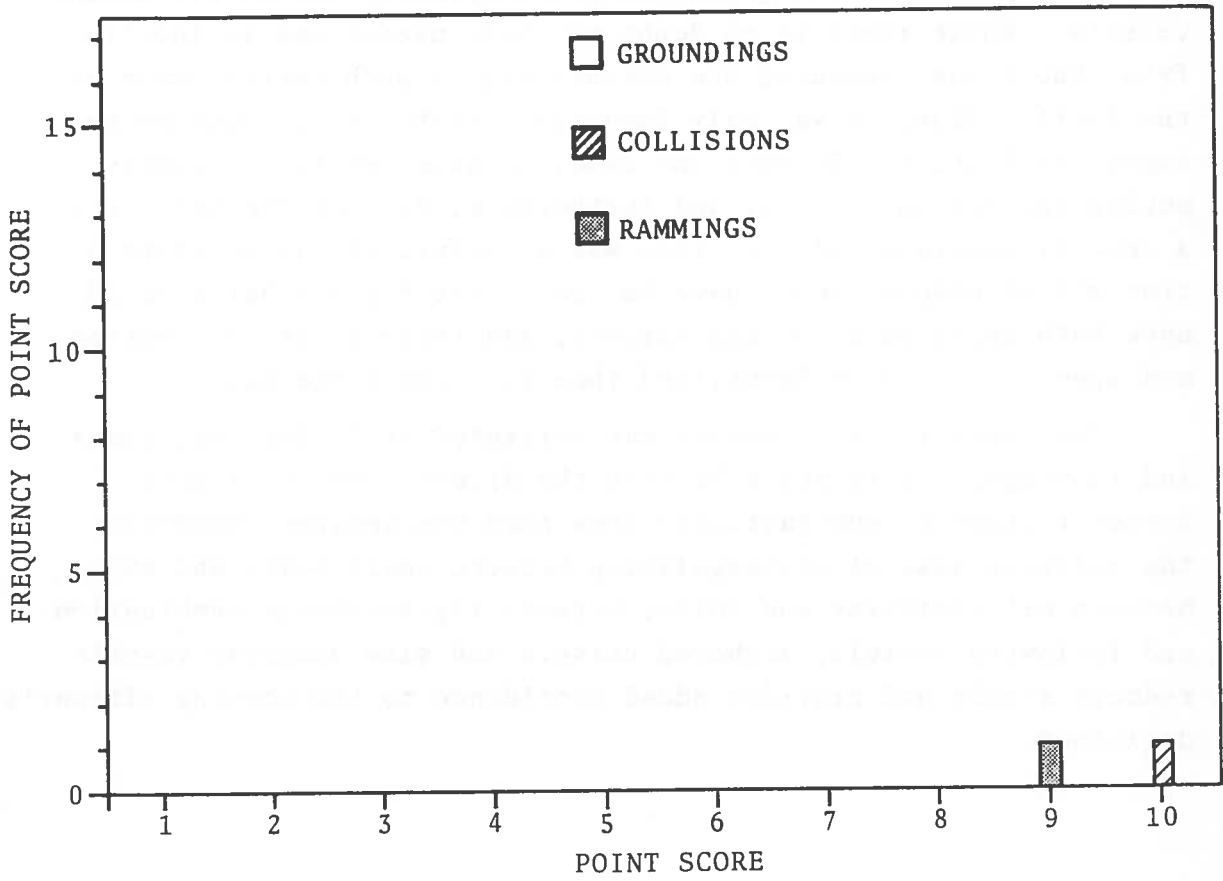

I.2.22 ABILITY TO OBTAIN DETERMINATION OF NON-MOVING RADAR TARGETS

Advocates for true-motion radars make much of the capability of the display to distinguish between stationary and slowly moving vessels. While there is no doubt of their usefulness in identifying buoys and providing the mariner with a much better sense of the traffic flow, it was only identified with one accident as an important feature. In this one case, a tanker mistook a slowly moving tug for an oil rig, and furthermore, mistook the barge for a second, separate vessel. This was a classic situation where a true motion display would have helped -- the tug and barge would have both appeared as moving targets, and their identical courses and speeds would have identified them as a tug-barge pair.

The overall effectiveness was estimated at 3% for collisions and rammings. It is probable that the direct benefit of this system feature is substantially less than the indirect benefits: the relative ease of distinguishing between small boats and buoys, between oil platforms and ships, between tug-and-barge combinations and following vessels, anchored vessels and slow underway vessels reduces strain and provides added confidence to the conning officer's decisions.

OPERATING FEATURE 22: ABILITY TO OBTAIN DETERMINATION
OF NON-MOVING RADAR TARGETS

(1) SCORING SUMMARY

- GROUNDINGS 0/0
- COLLISIONS 8/1
- RAMMINGS 0/0

Nature of Casualty	No. of Cases	% of Cases	Prob. of Prev.	Spec. Prev. Index
Groundings (55)	0	0	0	-
Collisions (17)	1	6%	5%	8
Rammings (6)	0	0.	0	-
Overall Rating	1	1% (4%*)	1% (3%*)	8

*Collisions and rammings only

(2) SPECIFIC ISSUES

None

(3) HISTOGRAM OF SCORES

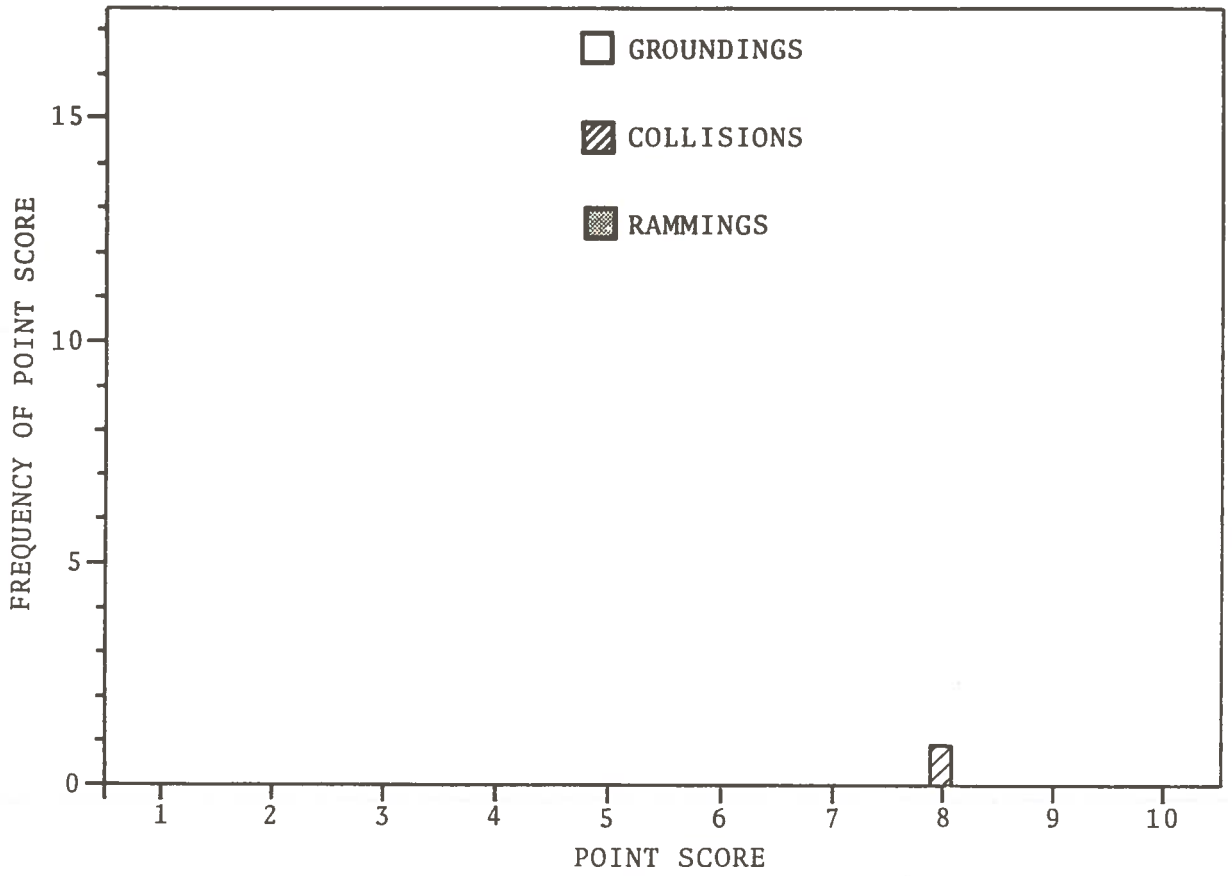

I.2.23 RACONS ON OIL PLATFORMS *

RACONS were discussed in Section I.2.20. Mounted on oil platforms, they could provide a strong, recognizable radar symbol which would be invaluable at night and in reduced visibility. However, there are hundreds of platforms in the Gulf of Mexico. Clearly not all should be RACON-equipped. Even to place one per cluster of platforms would not be particularly effective, because clusters are in charted locations -- little information would be conveyed, and the usefulness would be limited to a calibration of position, as described in I.2.20.

Large vessels will tend to use the fairways, especially at night and in reduced visibility, while shallower draft vessels and barges are less restricted. In section 4, it was noted that in three cases of rammings, the oil platforms were severely damaged, but lost no oil, due to the safety valve shutdown equipment. While rigorous estimates of the probability of oil spills by oil platforms were not available to the study team, it appears that a ramming by a vessel is not likely to cause an oil spill from the platform, but rather from the vessel. Thus it appears appropriate to confine attention to oil platforms bordering fairways.

A few RACONS placed on oil platforms bordering fairways would be helpful in preventing rammings, because they help define the fairway boundary and provide protection against the most likely platforms that would be involved in a ramming. If these RACONS were placed at locations remote from fairway intersections (where other RACONS should be placed) they could be helpful. This is discussed further in the Improved Aids to-Navigation System (see Section 5.2.9).

In the scoring, 3 out of 6 rammings would certainly have been prevented (specific prevention index: 10) by RACONS on the

*Since oil platforms are privately owned, the government/industry interface problem will need to be addressed to enable installation and proper maintenance.

platforms. However, one of these was not at the fairway boundary; the other two were. Of the other four, two occurred in broad daylight and involved non-tank barges being towed by tugs whose pilots misjudged the currents. Only one, the Globtic Sun, was a tanker, and it did ram a platform near the fairway border.

OPERATIONAL FEATURE 23: RACONS ON OIL PLATFORMS

(1) SCORING SUMMARY

POINT SCORE/NO. OF CASES:

- GROUNDINGS 0/0
- COLLISIONS 0/0
- RAMMINGS 29/3

Nature of Casualty	No. of Cases	% of Cases	Prob. of Prev.	Spec. Prev. Index
Groundings (55)	0	0	0	-
Collisions (17)	0	0	0	-
Rammings (6)	3	50%	48%	9.7
Overall Rating	3	4%	4%	9.7

(2) SPECIFIC ISSUES

Tankers: R-6
Barges: R-1, 3
Daytime: R-1, 3

(3) HISTOGRAM OF SCORES

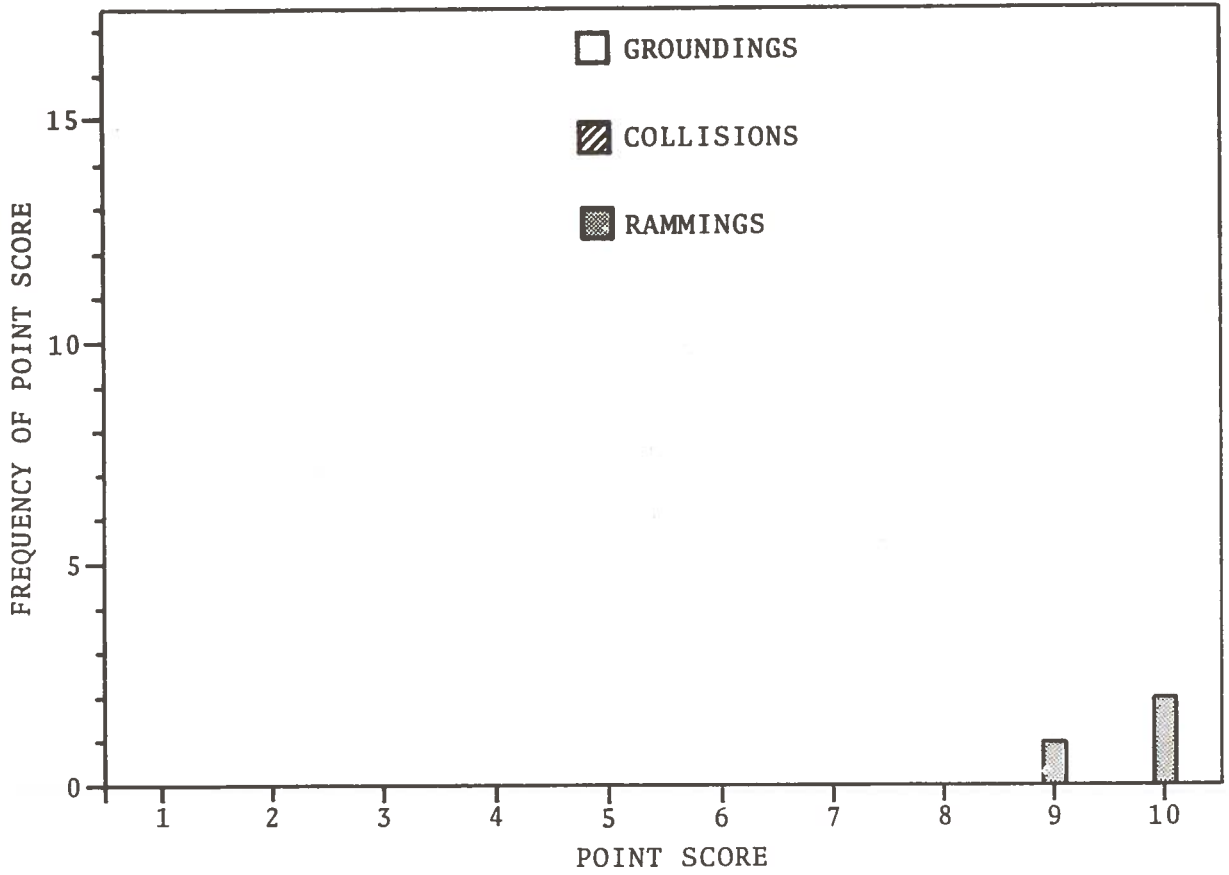

I.2.24 ALERT THAT A NEW VESSEL HAS APPEARED WITHIN ABOUT FIVE MILES OF OWN SHIP

This operational feature is intended to make the conning officer aware that a new vessel has appeared, and that the situation should be checked out. It is designed to eliminate casualties caused by lack of timely knowledge of the presence of the other vessel.

Of the 17 collisions, there were only 4 where neither vessel knew of the other's presence, and 4 others where only one knew of the other. In 7 of these 8 cases such an alert was felt to be of some value, but even there the SPI was 5; the reasons why it was not higher were primarily that even when the other vessel was detected, there was still time to avoid the collision, so that it was not certain that the added time available would have been helpful; also, maneuvers performed after the alert sounded would have indicated the alert is inadequate by itself. The probabilities of prevention are estimated at 19% for collisions, 0% for rammings and groundings, and 4% overall.

It is concluded that, by itself, this operational feature is not useful. However, combined with other features in a system, it offers some advantages.

OPERATIONAL FEATURE 24: ALERT THAT A NEW VESSEL HAS APPEARED
WITHIN ABOUT FIVE MILES OF OWN SHIP

(1) SCORING SUMMARY

POINT SCORE/NO. OF CASES:

- GROUNDINGS 0/0
- COLLISIONS 32/7
- RAMMINGS 0/0

Nature of Casualty	No. of Cases	% of Cases	Prob. of Prev.	Spec. Prev. Index
Groundings (55)	0	0	0	-
Collisions (17)	7	41%	19%	4.6
Rammings (6)	0	0	0	-
Overall Rating	7	8%	4%	4.6

(2) SPECIFIC ISSUES

Visual or Radar Contact by at Least One Ship before 5 miles: C-1, 2, 4, 5, 6, 7, 8, 9, 10, 11, 13, 15, 17

Both Ships knew of others presence before 5 miles
C-1, 4, 5, 6, 9, 10, 11, 13, 17

Neither knew of others presence before 5 miles
C-3, 12, 14, 16

Only one did
C-2, 7, 8, 15

(3) HISTOGRAM OF SCORES

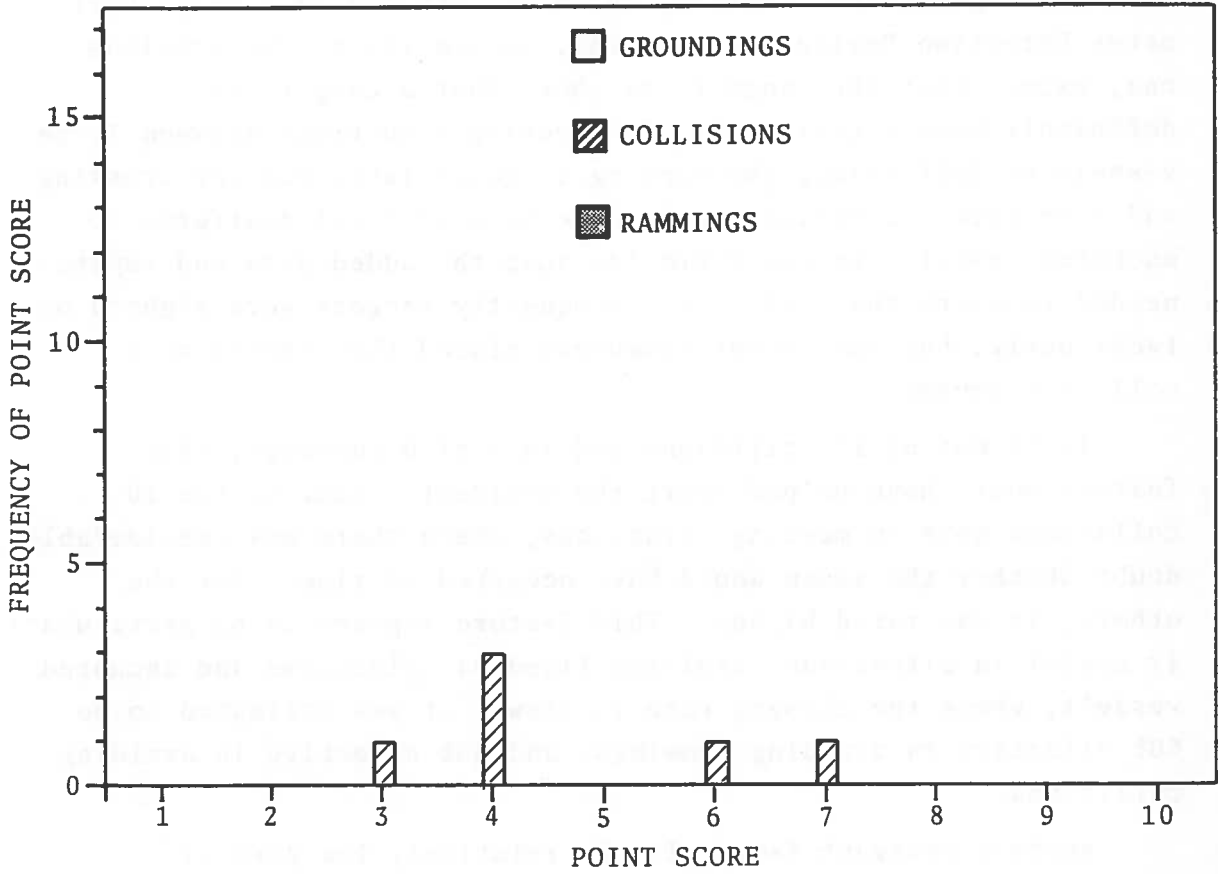

I.2.25 WARNING THAT A RADAR TARGET HAS COME WITHIN A SHORT RANGE OF OWN SHIP

This operational feature, which is embodied in a Radar Perimeter Detection Device (see 5.2.16), is similar to the previous one, except that its range is so short that a danger has definitely been established. For meeting situations between large vessels at full steam, the warning is quite late, but for crossing and overtaking situations, and those involving oil platforms or anchored vessels, it could provide just the added data and impetus needed to avert the collision. Frequently targets were sighted on radar early, but subsequent maneuvers placed the vessels on a collision course.

In 10 out of 17 collisions and in 4 of 6 rammings, this feature would have helped avert the accident. Four of the 10 collisions were in meeting situations, where there was considerable doubt whether the alarm would have occurred in time. For the others, it was rated higher. This feature appears to be particularly useful in situations involving fixed oil platforms and anchored vessels, where the closing rate is slow. It was estimated to be 60% effective in avoiding rammings, and 33% effective in avoiding collisions.

Another relevant factor is the relatively low cost of implementation, compared to collision avoidance aids, which makes it more attractive for tugs steering barges. This is discussed in Section 5.2.16.

OPERATIONAL FEATURE 25: WARNING THAT A RADAR TARGET HAS COME
WITHIN A SHORT RANGE OF OWN SHIP

(1) SCORING SUMMARY

POINT SCORE/NO. OF CASES:

- GROUNDINGS 0/0
- COLLISIONS 56/10
- RAMMINGS 36/4

Nature of Casualty	No. of Cases	% of Cases	Prob. of Prev.	Spec. Prev. Index
Groundings (55)	0	0	0	-
Collisions (17)	10	59%	33%	5.6
Rammings (6)	4	67%	60%	9.0
Overall Rating	14	18% (61%*)	11% (40%*)	6.6

*Rammings and collisions only

(2) SPECIFIC ISSUES

None

(3) HISTOGRAM OF SCORES

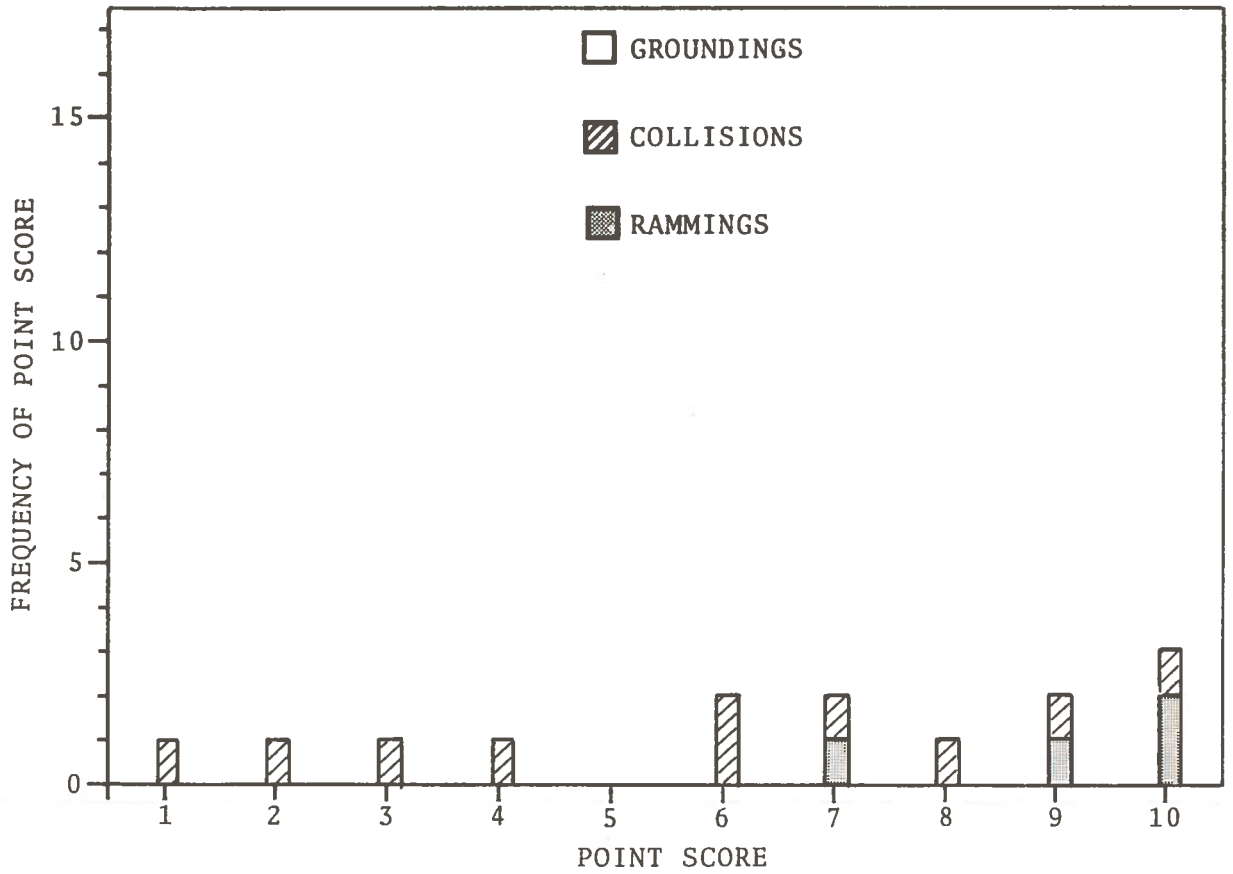

I.2.26 ABILITY TO OBTAIN RELATIVE POSITION AND COURSE PROJECTION OF RADAR TARGETS

This operational feature, which is embodied in radar plotting devices, requires constant attention by a bridge officer, who must take several readings on a target and plot the progress with a grease pencil or on a plotting board. More sophisticated collision avoidance aids allow the watchstander to acquire targets manually, after which the target's progress is automatically tracked, and the projected positions plotted. It is designed to help the mariner decide how close the passing will be, and to more effectively apply the Rules of the Road.

This capability appeared to provide some help in 9 of 17 collisions, in meeting and crossing situations, but at a relatively ineffectual level (SPI=3). The chief reason why this is not so effective is that it requires considerable attention and effort on the part of the watchstander, who is frequently using the radar for navigation, especially at night and in limited visibility. This is also indicated by the fact that in several accident reports, the master was cited for "failure to plot the other ship's course." While it can be argued that watchstanders should plot targets, there is in practice a reluctance to do so, perhaps due to workload limitations or to lack of proper attention.

The effectiveness was estimated at 18%, with a specific prevention index of 3. The feature appears in transponder and radar-based collision avoidance aids.

OPERATIONAL FEATURE 26: ABILITY TO OBTAIN RELATIVE POSITION
AND COURSE PROJECTION OF RADAR TARGETS

(1) SCORING SUMMARY

POINT SCORE/NO. OF CASES:

- GROUNDINGS 0/0
- COLLISIONS 30/9
- RAMMINGS 0/0

Nature of Casualty	No. of Cases	% of Cases	Prob. of Prev.	Spec. Prev. Index
Groundings (55)	0	0	0	-
Collisions (17)	9	53%	18%	3.3
Rammings (6)	0	0	0	-
Overall Rating	9	12%	4%	3.3

(2) SPECIFIC ISSUES

Meeting Situations and Crossing: C-2, 5, 8, 9, 10, 11, 12, 14, 16

(3) HISTOGRAM OF SCORES

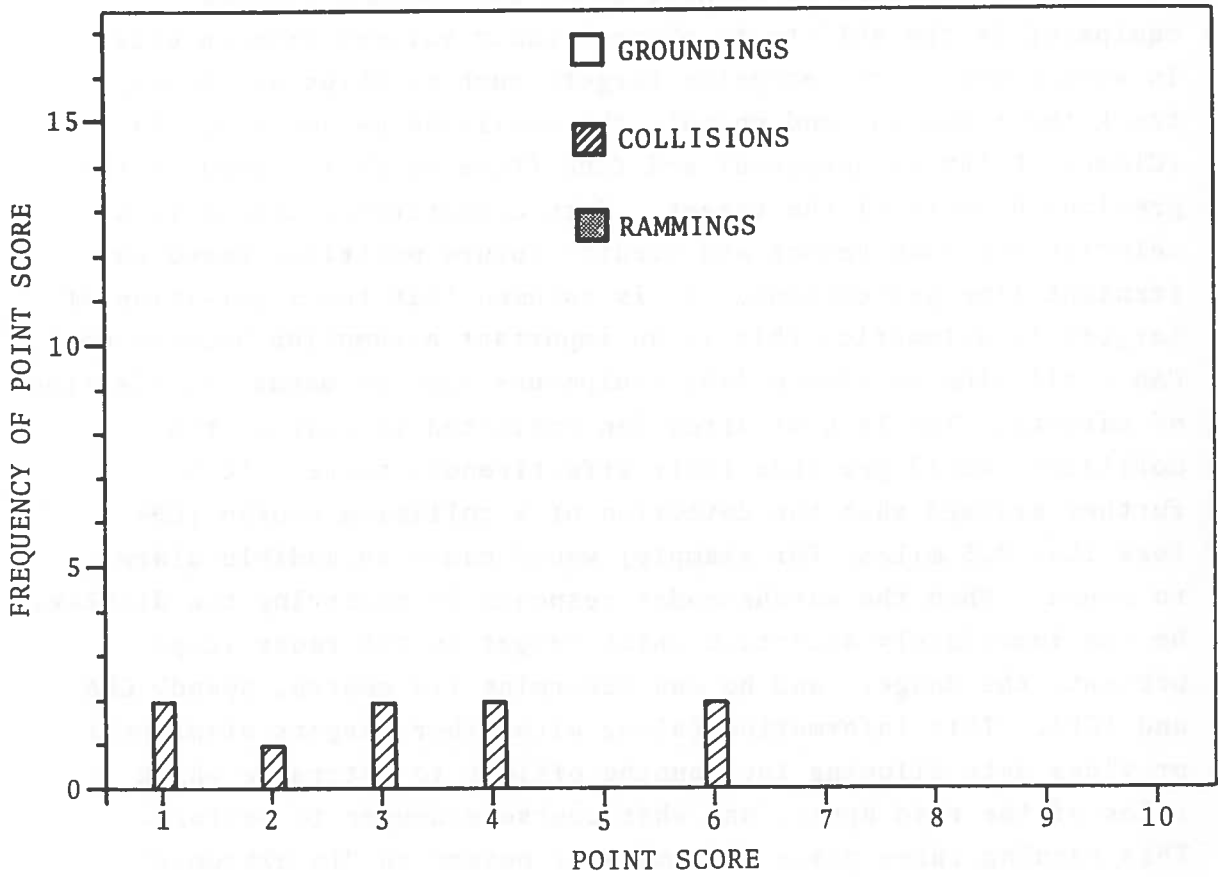

I.2.27 ALERT IF CONFLICT PREDICTED BY AUTOMATIC EQUIPMENT

The key feature of sophisticated collision avoidance equipment is the ability to process radar returns from objects in such a way as to recognize targets such as ships and buoys, track their motion, and compute the collision parameters, CPA (Closest Point of Approach) and TCPA (Time to CPA), based on the previous history of the target. Such computations calculate a velocity for each vessel and predict future positions based on straight line projections. It is assumed that the acquisition of targets is automatic; this is an important assumption because most CAA (Collision Avoidance Aid) equipments require manual acquisition of targets. The lack of attention exhibited in many of the collisions would preclude their effectiveness there. It is further assumed that the detection of a collision course (CPA less than 0.5 miles, for example) would cause an audible alarm to sound. When the watchstander responds by observing the display, he can immediately ascertain which target on the radar scope presents the danger, and he can determine its course, speed, CPA and TCPA. This information (along with other targets displayed) provides data allowing the conning officer to determine which rules of the road apply, and what course maneuver to perform. This warning takes place 5-20 minutes before an "in extremis" situation occurs.

The effectiveness of this feature is reduced by the fact that other vessels may maneuver. This possibility was considered in assessing the effectiveness of the operational feature in each collision in the data base.

Other factors were not considered: e.g., due to the cost of the equipment, not all vessels can afford this equipment, especially tugs. The loss in effectiveness due to this factor is considered in Section 5.2.15 where system implementations are discussed.

Assuming the operational feature is available to all vessels, the effectiveness is 62% for collisions, and 60% for rammings. 14 out of 17 collisions would have been less likely, and 4 out of 6 rammings. The SPI for collisions and rammings was 8; thus, where it would have helped at all, it would have been quite effective.

OPERATIONAL FEATURE 27: ALERT IF CONFLICT PREDICTED BY
AUTOMATIC EQUIPMENT

(1) SCORING SUMMARY

POINT SCORE/NO. OF CASES:

- GROUNDINGS 0/0
- COLLISIONS 106/14
- RAMMINGS 36/4

Nature of Casualty	No. of Cases	% of Cases	Prob. of Prev.	Spec. Prev. Index
Groundings (55)	0	0	0	-
Collisions (17)	14	82%	62%	7.6
Rammings (6)	4	67%	69%	9
Overall Rating	18	23% (78%*)	18% (62%*)	7.9

*Ignoring groundings

(2) SPECIFIC ISSUES

None

(3) HISTOGRAM OF SCORES

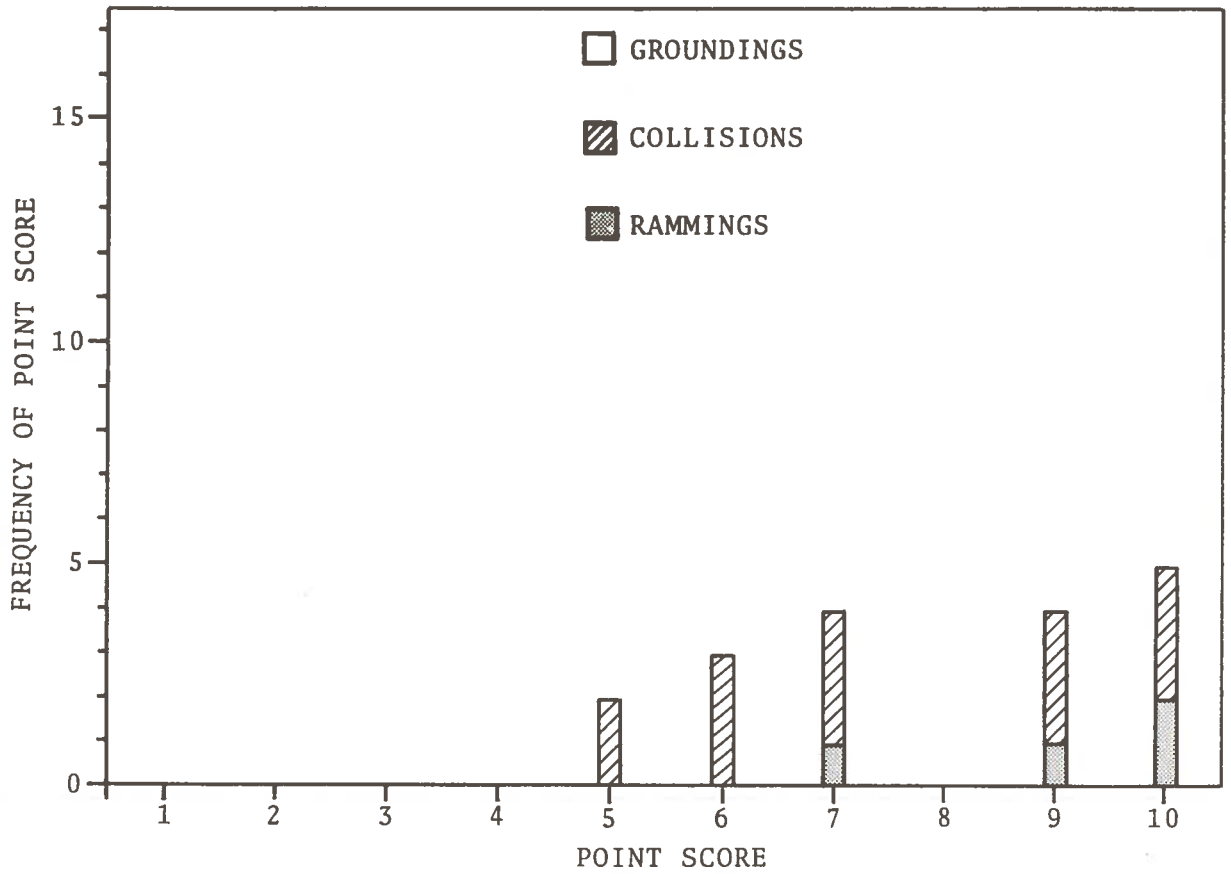

I.2.28 ABILITY TO OBTAIN IMMEDIATE RADIO CONTACT WITH A
SELECTED VESSEL

This operational feature is the capability for a conning officer to contact a selected vessel to coordinate a passing. Presently there is a reluctance on the part of bridge officers to use the VHF radio telephone to coordinate passing maneuvers in open ocean (of the 17 data base casualties, in only two was radio contact made before the collision). Inland, on the other hand, the usage of the radiotelephone for this purpose has increased since the initiation of the regulations incorporating the provisions of the Bridge-to-Bridge Radio-Telephone Act (Public Law 92-63, 4 August 1971). It is now routinely used on inland waterways, especially rivers and channels, where close passings are frequent and necessary.

The reluctance to use the radiotelephone to coordinate passings appears to be based on three factors:

- a. The time-honored tradition of autonomy of ships on the high seas leads to an attitude of "I'm navigating my ship the way I should -- if the other captain does the same and follows the Rules of the Road, there will be no collision -- why should I waste my time talking to him?"
- b. It is much more difficult in open waters to establish with certainty the fact that the communicating vessel is the correct one.
- c. VHF sets are frequently tuned to channels other than 13, the designated bridge-to-bridge channel.
- d. The poor English speaking ability of the international officer population can make such attempts frustrating or futile.

There is presently no means on board of selectively calling a particular vessel, i.e., a particular target on the radar. However, there are experimental systems which can provide target identification (5.2.17 and 5.2.18), and there is no technological reason why such a feature cannot be invented.

Such an operational feature being feasible, its effectiveness was evaluated assuming that each watchstander had the ability either to obtain some identifying code of the radar target vessel that could be used on the radiotelephone to attract the other's attention, or to selectively ring up that vessel. In either case the tasks of selecting the target, identifying it, and making the call, all have to be performed. Thus the second reason for not using the radio-telephone is obviated. It is assumed, too, that ships will monitor channel 13, a practice that is increasing.

It is impossible to account for the attitudinal factor in the evaluation of the operational feature, so that the conclusions here must be interpreted with this in mind. Through training, younger skippers will incorporate the use of radiotelephones into this modus operandi, and others will also, in an attempt to accommodate the increased national concern over oil spills.

This capability was deemed to be possibly helpful in 12 of 17 collisions, with a specific prevention index of 6. The chief criterion used in evaluating each case centered on the time before collision that one captain recognized there was a problem; the judgment was then made on the probability that communication at that time would have been helpful in avoiding the accident.

The overall effectiveness was estimated at 44% for collisions. It clearly has no function in rammings or groundings.

OPERATIONAL FEATURE 28: ABILITY TO OBTAIN IMMEDIATE RADIO CONTACT
WITH A SELECTED VESSEL

(1) SCORING SUMMARY

POINT SCORE/NO. OF CASES:

- GROUNDINGS 0/0
- COLLISIONS 74/12
- RAMMINGS 0/0

Nature of Casualty	No. of Cases	% of Cases	Prob. of Prev.	Spec. Prev. Index
Groundings (55)	0	0	0	-
Collisions (17)	12	71%	44%	6.2
Rammings (6)	0	0	0	-
Overall Rating	12	15% (71%*)	9% (44%*)	6.2

*Collisions only

(2) SPECIFIC ISSUES

None

(3) HISTOGRAM OF SCORES

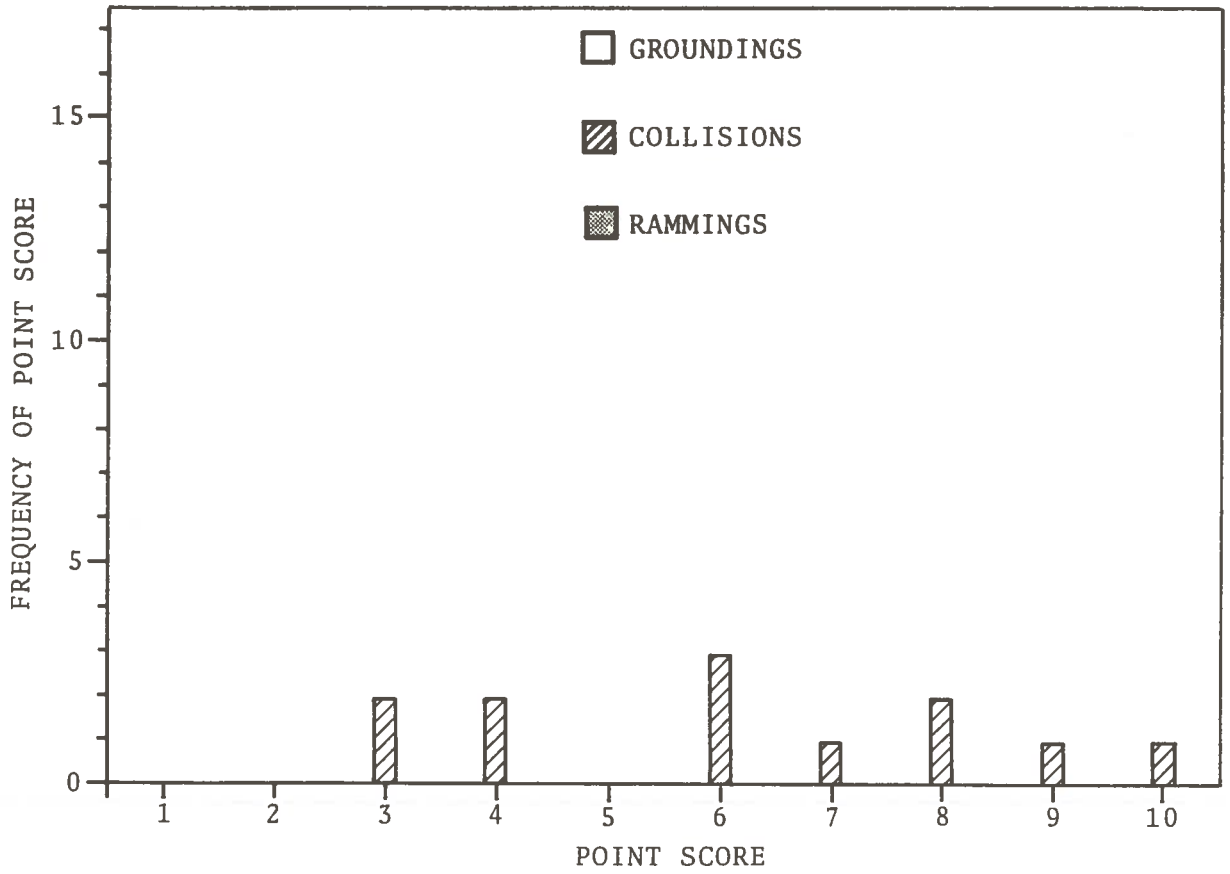

I.2.29 ABILITY TO OBTAIN MANEUVERING INTENT OF OTHER VESSELS

This operational feature is more limited than the previous one. The question here is "if it were possible to interrogate the other vessel in some manner, or otherwise determine her imminent course changes, if any, would that information have been adequate to enable actions solely on the part of own vessel to avoid the collision?" This information could be visual ("turn signals on ship"), a radar alphanumeric tag (5.2.18), or a display (5.2.17). This data could be especially useful when planned course changes occur, and when a course is modified slightly to increase the passing distance (frequently collisions are caused by conflicting course changes on the part of both vessels). CAORF preliminary simulation studies have indicated that such information is useful, if it is specific enough (Pollack, 1977).

It was judged to be potentially helpful in 8 of 17 collisions, with a specific prevention index of 6. The probability of prevention was estimated at 27% for collisions.

OPERATIONAL FEATURE 29: ABILITY TO OBTAIN MANEUVERING
INTENT OF OTHER VESSELS

(1) SCORING SUMMARY

POINT SCORE/NO. OF CASES:

- GROUNDINGS 0/0
- COLLISIONS 46/8
- RAMMINGS 0/0

Nature of Casualty	No. of Cases	% of Cases	Prob. of Prev.	Spec. Prev. Index
Groundings (55)	0	0	0	-
Collisions (17)	8	47%	27%	5.8
Rammings (6)	0	0	0	-
Overall Rating	8	10%	6%	5.8

(2) SPECIFIC ISSUES

None

(3) HISTOGRAM OF SCORES

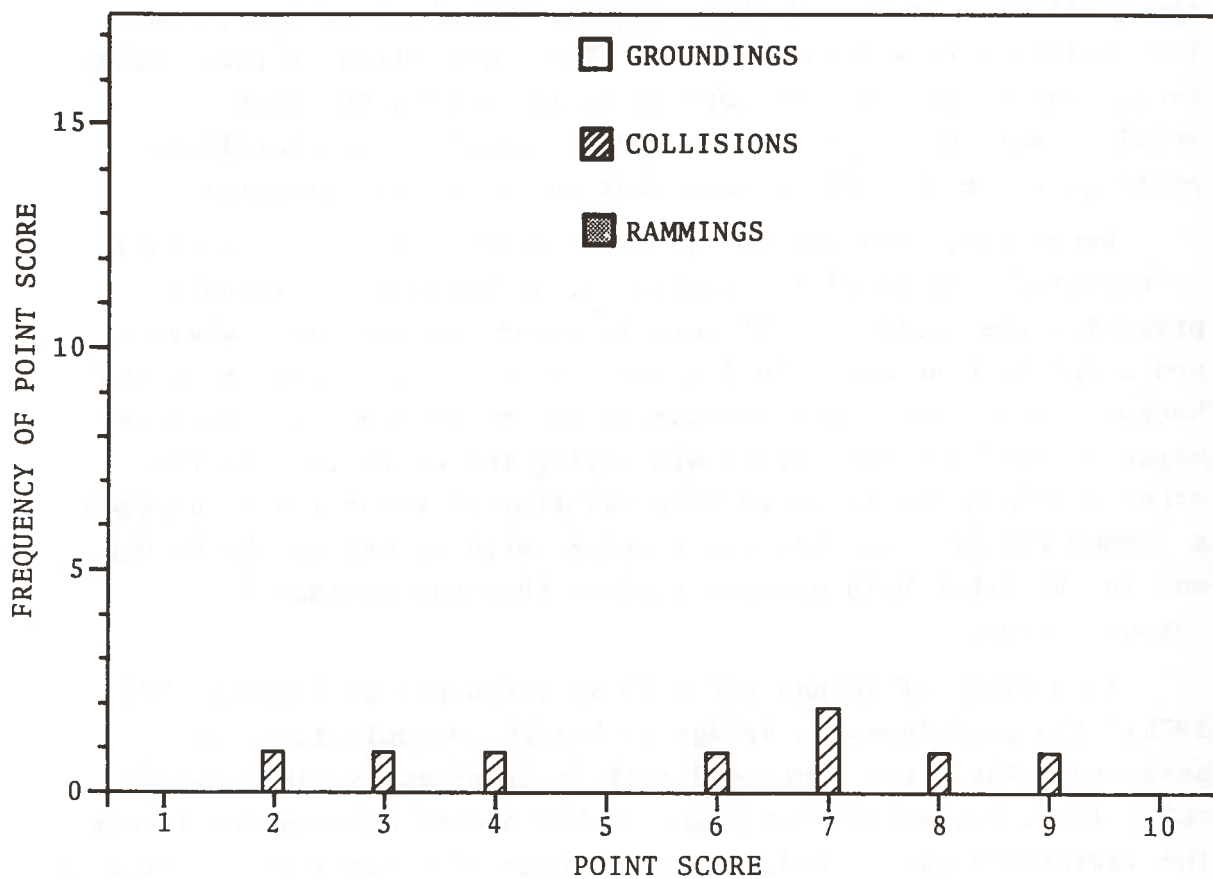

I.2.30 INCENTIVE TO COMMUNICATE WITH OTHER VESSELS TO EFFECT PASSINGS

This operational feature was postulated in order to answer the question, "if vessels had communicated ahead of time, could the collision have been avoided?" The supposition is that strong enough sanctions would be imposed to force even the most recalcitrant ship captain to use VHF channel 13 to coordinate passings where the CPA is less than one mile (for example).

Generally, this feature is quite effective (64%), as would be expected. In 11 of 17 collisions, it would have virtually prevented the accident. Of more interest are the cases where it would not have helped. In 2 cases, it would have been of no use because the vessels were communicating; in another, a lightering barge scraped a tanker after misjudging the currents. In the other 3 collisions it would have had limited value: one involved a jammed rudder, one involved a vessel with no one on the bridge, and in the other both masters claimed they had attempted communication.

In a study of inland (as well as offshore) collisions (ORI, 1975), the usefulness of bridge-to-bridge communications was assessed. The study concluded that it is effective in reducing collisions, but noted that since it has become more common to use the radiotelephone inland, the percentage of collisions potentially preventable by radiotelephone has decreased. As a result, the effectiveness of the radio-telephone for offshore purposes noted in the present study is consistent with the statistics of the ORI report for the years prior to 1970, namely around 50-60%.

This feature is not as obvious in its application to a system; it is included rather to clarify the potential for improved bridge-to-bridge communications.

OPERATIONAL FEATURE 30: INCENTIVE TO COMMUNICATE WITH OTHER
VESSELS TO EFFECT PASSINGS

(1) SCORING SUMMARY

POINT SCORE/NO. OF CASES:

- GROUNDINGS 0/0
- COLLISIONS 109/15
- RAMMINGS 0/0

Nature of Casualty	No. of Cases	% of Cases	Prob. of Prev.	Spec. Prev. Index
Groundings (55)	0	0	0	-
Collisions (17)	15	88%	64%	7.3
Rammings (6)	0	0	0	-
Overall Rating	15	19%	14%	7.3

(2) SPECIFIC ISSUES

None

(3) HISTOGRAM OF SCORES

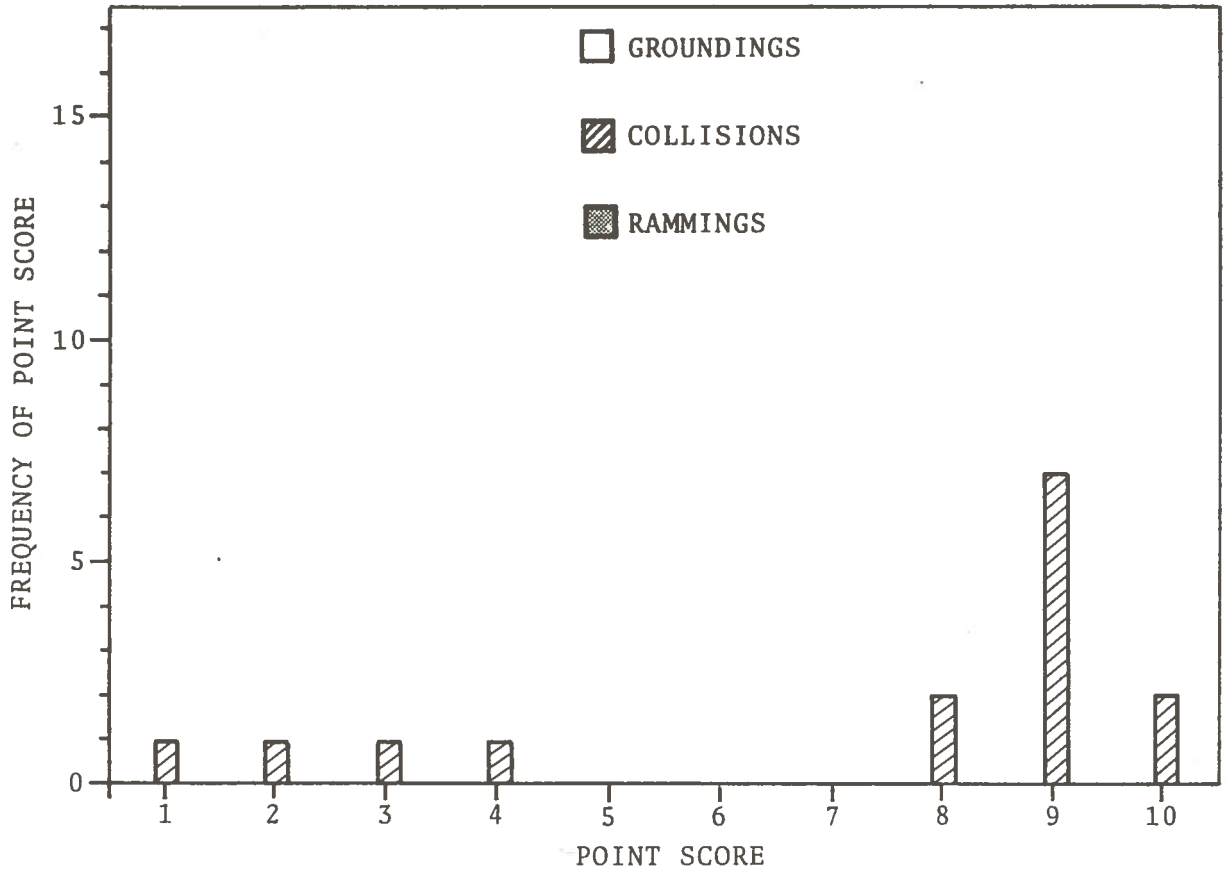

I.2.31 GENERAL ADVISORY OF CURRENTS, TIDES, WEATHER, OUTAGES

There were 11 casualties where a lack of knowledge on the vesselmaster's part played a central role in the incidents. In each case a shore station could have helped by notifying mariners of the problem. Strong currents played a part in a large number of cases, but in three it was concluded that more than poor navigating was involved. In three other cases, buoys were moved, a radiobeacon was out, and a light was out; in two others, a recent buoy location change contributed to the grounding. Unusual and unexpected winds, fog, and low tides were factors in the other three. There were several other cases where buoy outages were unknown to the vesselmaster, but where the outages didn't play a direct part in the accident.

The study team was struck by the inability of the present communications system to alert mariners to unusual conditions. Buoy outages apparently went undetected for several days -- although ships must have passed these points and been aware of outages. The reporting system proved undependable, because the Coast Guard was apparently unaware of the buoy outages. Even when the Coast Guard is aware of such a problem, the means for altering the mariners are inadequate: notices to mariners don't get published for several days, and the chance of a vessel arriving from a distant port having notices issued in the last few days (or even weeks) is small. Broadcasts are presumably made on a twice-per-day schedule, but these are often missed -- the ship's radio officer may or may not be on watch at the time.

There are several approaches to improving the situation:

- a. Shipmaster could be strongly encouraged to report any unusual conditions that the Coast Guard may not be aware of.
- b. Each Coast Guard district could have an officer responsible for the assimilation of reported conditions, their broadcast, and their publication, where appropriate.

- c. Broadcasts could be issued at established 6-hour intervals, and radiotelegraph transmissions at 12-hour intervals to insure that arrivals from distant ports are informed.
- d. As a further step, tankers specifically could contact, or be contacted by, a Coast Guard station to ensure that all such conditions are known.
- e. This service could be extended to all commercial vessels.

If such an operational feature were effected, the probability of prevention is estimated at 8% for groundings, with a specific prevention index of 6. More significantly, in 8 of the 10 groundings, the operational feature would have provided a better chance than the baseline system of a navigation display; an estimated 5% more groundings could be prevented over and above the baseline system.

OPERATIONAL FEATURE 31: GENERAL ADVISORY OF CURRENTS, TIDES
WEATHER, OUTAGES

(1) SCORING SUMMARY

POINT SCORE/NO. OF CASES:

- GROUNDINGS 55/10
- COLLISIONS 7/1
- RAMMINGS 0/0

Nature of Casualty	No. of Cases	% of Cases	Prob. of Prev.	Spec. Prev. Index
Groundings (55)	10	18%	10%	5.5
Collisions (17)	1	6%	4%	7
Rammings (6)	0	0	0	-
Overall Rating	11	14%	8%	5.6

(2) SPECIFIC ISSUES

Currents: C-13; G-16, 34
Outages: G-43 (MF beacon), 24 (Light); 17 (Buoy moved)
High Water: G-40 (Barge)
Fog: G-20
Abnormally Low Tide: G-32
Buoy Change: G-8, 10

(3) HISTOGRAM OF SCORES

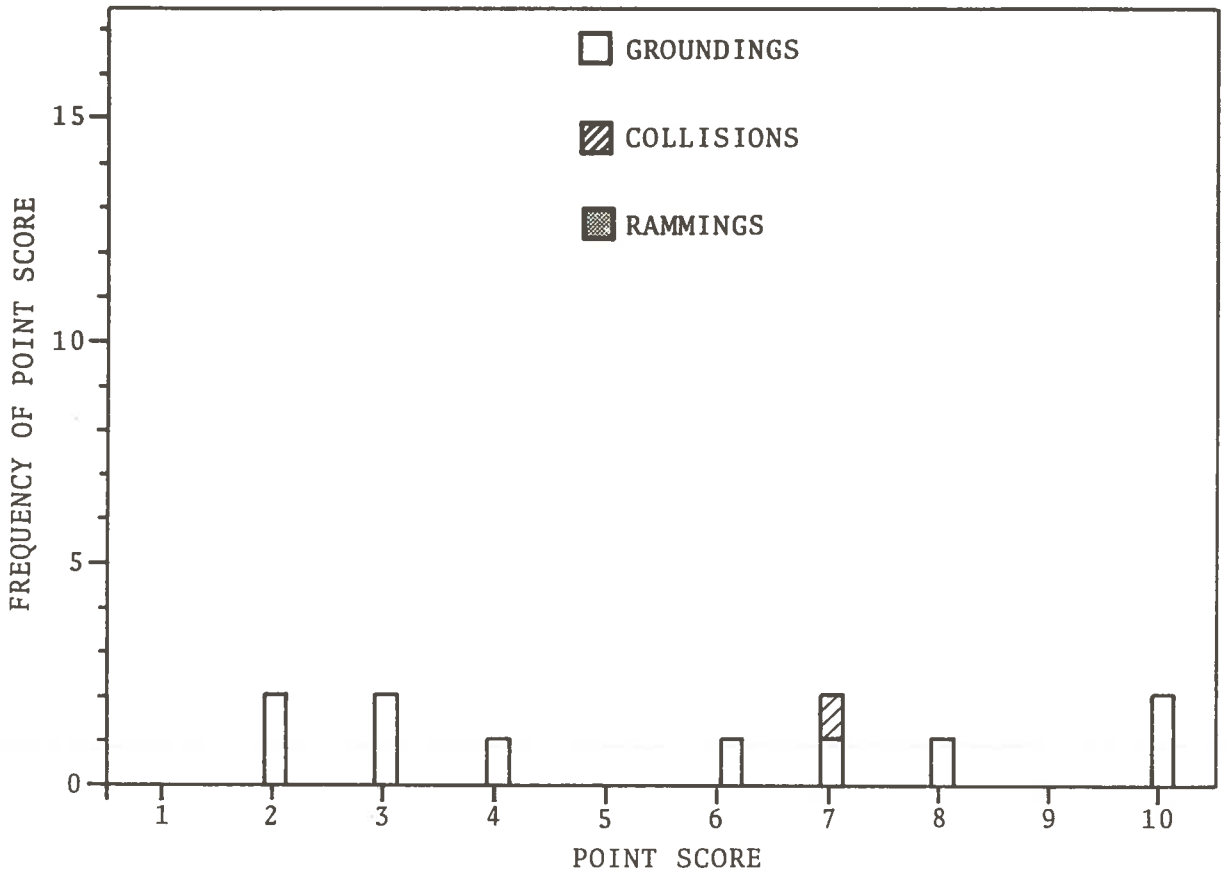

I.2.32 VOYAGE PLAN AND CHECKLIST SUBMISSION

The purpose of this operational feature is three-fold:

- a. Forcing the vesselmaster to cross-check instruments and enter chart changes before approaching port.
- b. Forcing the vesselmaster to take a fix before approaching port.
- c. Asking the vesselmaster to report to shore on missing or inadequate charts, or missing notices to mariners.

This feature is designed to help focus the attention of the vesselmaster on his increased responsibility near the shore.

The mechanism for achieving this feature could take several forms:

- a. A standard form to be filled out, and a broadcast to shore only if exceptions are found.
- b. A ship/shore voluntary broadcast that the checklist (a standardized form) has been accomplished, with exceptions noted.
- c. A ship/shore communications in the form of a series of questions from shore.

If exceptions were noted, some shore actions could be taken:

- a. Where charts were inadequate, pilots could be asked to carry the charts and meet the tankers further out.
- b. Where Notices to Mariners were missing from the ship, the shore station could review them, and inform the ship of conditions likely to affect her.
- c. Where key navigation gear like radars were out, the shore station could recommend large margins, or daytime entry to port.

The evaluation of this operational feature is highly subjective, for several reasons:

- a. The reporting and cross-checking could be peremptorily treated, defeating its purpose.

- b. The effectiveness is highly dependent on sanctions and enforcement.
- c. There could be a reluctance by Coast Guard personnel to provide information from Notices to Mariners, for fear it would encourage bad habits on the part of the ship's officers, and further increase workload.

Assuming that a satisfactory arrangement could be worked out, the probability of prevention was estimated at 9%, with a specific prevention index of 6, which is fairly high. Thus, while only 22% of the groundings (12 cases) would benefit by such an operational feature, it would be quite beneficial for those cases.

The application of this operational feature is discussed further in Section 5.2.2.

OPERATIONAL FEATURE 32: VOYAGE PLAN AND CHECKLIST SUBMISSION

(1) SCORING SUMMARY

POINT SCORE/NO. OF CASES:

- GROUNDINGS 73/12
- COLLISIONS 0/0
- RAMMINGS 0/0

Nature of Casualty	No. of Cases	% of Cases	Prob. of Prev.	Spec. Prev. Index
Groundings (55)	12	22%	13%	6.1
Collisions (17)	0	0	0	-
Rammings (6)	0	0	0	-
Overall Rating	12	15%	9%	6.1

(2) SPECIFIC ISSUES

Radar Out: G-2*, 20, 21
 Radar Turned Off: G-3
 Navigation Gear Out: G-23
 Fathometer Out: G-20, 23
 Gyro Error: G-42, 44
 Gyro Reporter Error: G-29
 Inadequate or Missing Charts: G-7, 12, 38
 Notices to Mariners Missing: G-8, 10
 Forced to Establish Position Before Entering: G-23

*Did not score - X-band radar was working, but S-band wasn't.

(3) HISTOGRAM OF SCORES

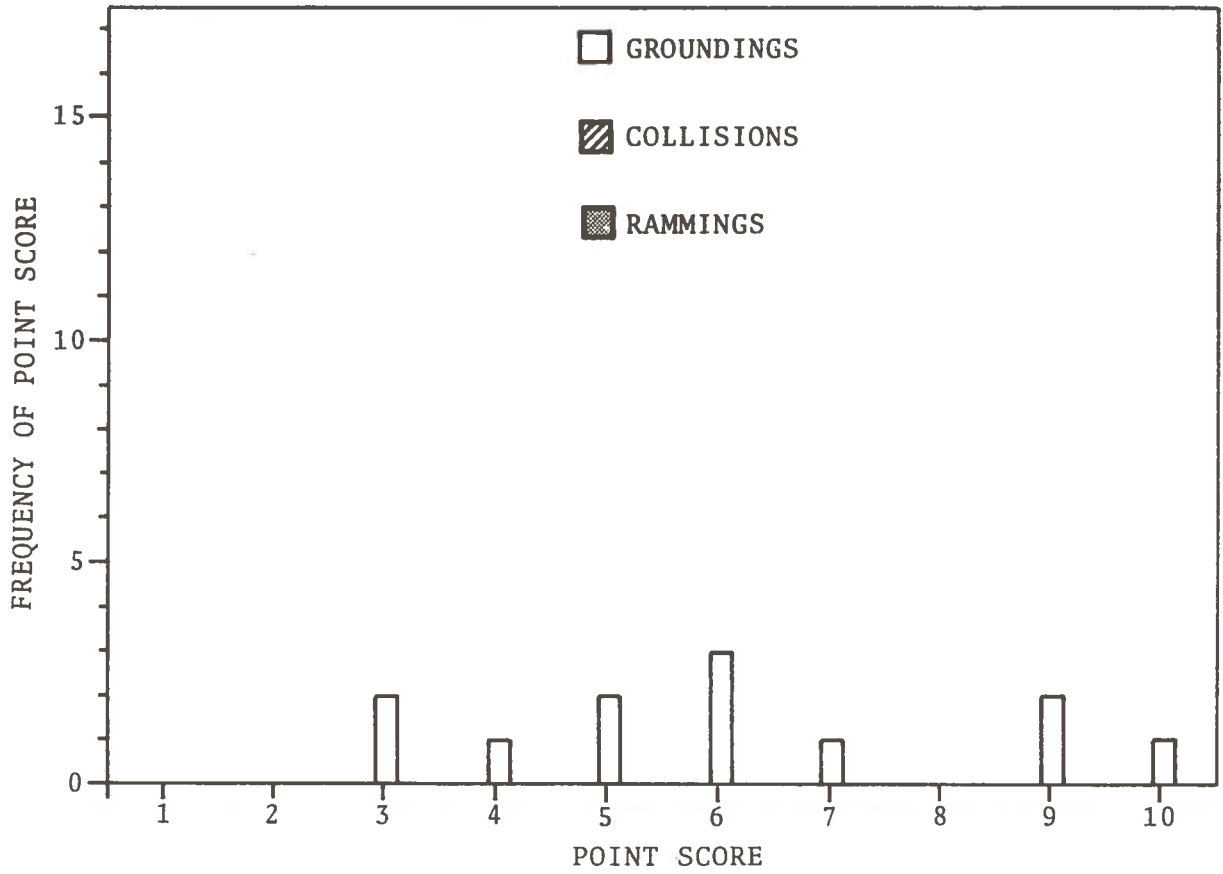

I.2.33 MANUAL MONITORING STATIONS

This operational feature assumes a shore-based station obtaining periodic reports from each vessel, citing her position, course, and speed. These reports would be used to project future positions of ships, either by moving targets manually by dead reckoning along a plotting board, or by a computer-driven display which accomplishes the same function.

This feature would provide services similar to the present Vessel Traffic Services (VTSs) in Houston, New Orleans, San Francisco, Valdez, and Puget Sound. The ways in which an on-shore station could provide help are numerous, including facilitating vessel-to-vessel communications and forcing the conning officer to cross-check his instruments and take a fix.

The system feature was assessed by assuming that the services shown in Table I-2 were available -- it was assumed in all cases that shore-to-ship contact was always available, and that vessels would report their positions every 15 minutes or so within 25 miles of the 3-mile territorial limit, and every half-hour or so out to 200 miles. All ships of 1000 gross tons or more are assumed to be part of such a system. Problems with implementation were ignored for this assessment -- such difficulties are covered under the system implementations.

Table I-2 shows the services that a manual monitoring station would provide in the case of the casualties in the data base; it also shows the number of casualties that would have been influenced by the particular service. Also shown is the specific prevention index (SPI) which provides an indication of that service's relative effectiveness for those cases, on a scale of 0-10.

Manual monitoring stations would have some effect in a total of 59 out of 78 casualties with a total probability of prevention of 44%, and a specific prevention index of 6. In rows 5-8, and row 17 of Table I-2 are indicated several causes of casualties where a manual monitoring station would not have been helpful:

- a. Collisions where one vessel is not in the system

TABLE I-2. NUMBER OF CASES WHERE SERVICES PROVIDED BY A MANUAL MONITORING STATION WOULD HAVE PROVED USEFUL

NO.	SERVICE PROVIDED	COLLs	RAMs	GNDGs	SPI
1	Aid in establishing vessel/ vessel communication	8	0	0	8
2	Detection of collision conflict	5	2	0	6
3	Advice on currents	1	2	1	5
4	Force lookout on bridge	1	0	1	4
5	None* - one vessel in innocent passage	1	0	0	0
6	None* - Too sudden or insufficient accuracy	1	1	11	0
7	None* - Vessel would give incorrect position	0	1	2	0
8	None* - Uncharted shoal, reef or submerged object	0	0	4	0
9	Force vesselmaster to take a fix	0	0	6	7
10	Detection of closeness of shoal or reef	0	0	12	5
11	Advise to increase margin	0	0	3	6
12	Advise to take traffic lane	0	0	2	9
13	Advise to stay out from shore, temporarily	0	0	4	5
14	Advise of danger	0	0	4	4
15	Advise of buoy changes	0	0	4	5
16	Help in approaching port	0	0	2	8
17	None* - special problems	0	0	4	0

*None means no service is provided

- b. Accidents where the reported position would not have been accurate enough or timely enough for the shore station to help.
- c. Groundings where the incorrect position would have been reported.
- d. Uncharted shoal, reef, or coral boulder involved.
- e. Special problems such as sudden loss of steering, and aiding a vessel in distress.

In the 17 collisions, manual monitoring stations would have provided substantial help in 15 cases (probability of prevention - 62% and SPI - 7). This help would come chiefly in the form of establishing early contact between vessels and early detection of the conflict (rows 1 and 2 of Table I-1). Even though in most cases vessels were aware of the other's presence, they were often unaware of the danger (see I-2.24). When they were aware of the problem, they did not communicate, probably due to the uncertainties involved in establishing contact; in only one collision was radio contact actually obtained before the collision occurred. The SPI for collision conflict (row 2, Table I-2) is 6, which is higher than anticipated: it indicates that even with the inaccuracies of verbal reporting, the shore station could have been aware of a danger of collision 60% of the time. The automatic monitoring feature (I.2.34) would be higher. Thus a shorebased manual station could provide a valuable collision-avoidance service, if it was not provided by vessel equipment and procedures.

Manual monitoring stations, if fully capable of rapid establishment of communication out to 100 miles or so, would have been helpful in 4 out of 6 ramblings, but at a relatively ineffectual level: the probability of prevention was 27%, and the SPI, 4. In two of the ramming cases the shore might have detected a problem; in the other two, providing the speed and direction of the currents to the vesselmaster from shore might have helped.

Manual monitoring stations would have helped in 39 of the 55 groundings, with a specific prevention index of 6. The chief

services provided by such a station would be, in order of their effectiveness on the groundings in the data base:

- a. Detection of vessel's proximity to shoal or reef, and a warning to the vesselmaster (10.9%).
- b. Forcing the vesselmaster to check his position (7.7%).
- c. Advice on buoy changes, outages (3.6%).
- d. Advice to stay out until weather improves (3.6%).
- e. Advice to increase margins in skirting reefs (3.2%).
- f. Advice to take particular traffic lanes (3.2%).

Other services include help in approaching when special problems occur (lack of charts, steering problem), advice on particularly deceptive areas (where groundings are frequent), advice on currents, and forcing the vessel to maintain a lookout on the bridge.

In the assessment the warnings and advice were not assumed to be 100% effective. The team attempted in each casualty to gauge the effectiveness of the advice by considering the general vigilance of the conning officer, the time of day, the visibility, the familiarity of the conning officer with the area (sometimes pilots were involved), the frequency of position reports, and the condition of electronic gear.

The problems of implementation, and questions of station location, were ignored in order to evaluate the operational feature on its own merits. These problems are treated in Section 5.3.13.

OPERATIONAL FEATURE 33: MANUAL MONITORING STATIONS

(1) SCORING SUMMARY

POINT SCORE/NO. OF CASES:

- GROUNDINGS 219/39
- COLLISIONS 105/15
- RAMMINGS 16/4

Nature of Casualty	No. of Cases	% of Cases	Prob. of Prev.	Spec. Prev. Index
Groundings (55)	39	71%	40%	5.6
Collisions (17)	15	88%	62%	7.0
Rammings (6)	4	66%	27%	4.0
Overall Rating	58	74%	44%	5.9

(2) SPECIFIC ISSUES

Aid in establishing vessel/vessel comm: C-1, 5, 9, 10, 11, 14, 16
 Comm. relay: C-12
 Detection of conflict: C-2, 3, 4, 8, 15: R-4, 6
 Innocent passage: C-2
 Advice on currents: C-13; R-1, 3; G-53
 Too quick to detect conflict: C-6 (jammed rudder)
 Force lookout on bridge: C-7; G-25
 None - Vessel would give incorrect report: R5: G-28, 35
 No effect - Vessel would give "insufficiently accurate report":
 R-2; G-1, 4, 11, 16, 17, 26, 28, 31, 34, 35, 40
 Force VM to take and report a fix: G-3, 18, 23, 36, 46, 47
 Force bridge to take a depth sounding: G-2
 Would detect closeness to shoal or reef: G-9, 13, 14, 29, 30,
 32, 38, 39, 42, 45, 50, 54
 Would advise to stay out: G-20, 27, 43, 51
 Would advise to increase margin: G-6, 21, 41
 Would advise to take a traffic lane: G-44, 49
 Special problems - no effect - G-15 (barge), 22 (Burning
 vessel aid), 25 (lite bulb), 33 (in channel)
 Provide escort by "vessel of opportunity": G-37
 Would have helped in - chart missing: G-7, 12
 Advice on buoy changes: G-7, 8, 10, 24
 Reminder of danger: G-7, 24, 30, 55
 Fatigue: G-52
 None - Uncharted shoal or reef: G-19, 33, 34, 48
Miles from Nearest Port: (Collisions/Rammings/Groundings)

0-3:	3	0	22
3-12:	5	0	20
12-20:	5	1	7
>20:	4	5	6

(3) HISTOGRAM OF SCORES

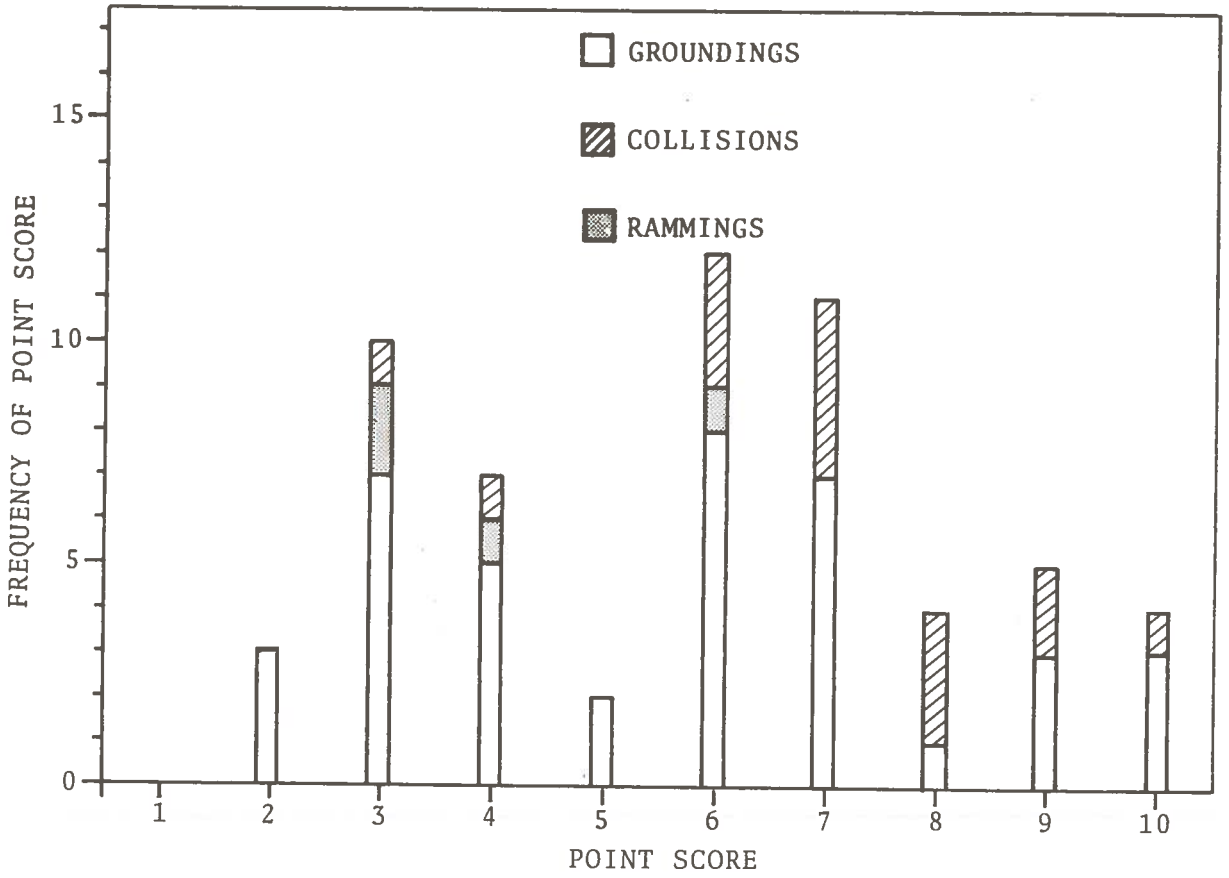

I.2.34 AUTOMATIC MONITORING STATIONS

In this operational feature, it is assumed that vessel position is automatically radioed about every 5 minutes from each vessel, with no effort required on the part of the bridge officers. It is further assumed that an absolute accuracy on the order of 0.25 miles is achieved while short term drift and noise errors are less than about 300 feet. This accuracy along with the frequency of data update makes it possible to project future vessel positions with certainty.

In 9 collisions, 3 rammings, and 28 groundings, this advantage was adjudged to provide some benefit over the manual monitoring system, where the reports are verbal and less frequent. The difference, of course, was most dramatic in those cases where the vesselmaster did not know his location well. When the baseline system is incorporated into the system (which is done in Section 5.2.3) this difference will not be as large.

The effect of adding automatic monitoring to the shore station capabilities is to increase the overall probability of prevention from 44% to 69%. For collisions, it increases from 62% to 79%; for rammings, from 27% to 65%; and for groundings, from 40% to 66%. The specific prevention index rises by about 2 points in all categories; the overall SPI is 8. This means that in those cases where an automatic monitoring station would help at all it would be 80% effective.

There were only three cases where further increases in accuracy over and above the baseline system were believed to provide further benefits.

OPERATIONAL FEATURE 34: AUTOMATIC MONITORING SYSTEM

(1) SCORING SUMMARY

POINT SCORE/NO. OF CASES:

- GROUNDINGS 362/46
- COLLISIONS 134/15
- RAMMINGS 39/6

Nature of Casualty	No. of Cases	% of Cases	Prob. of Prev.	Spec. Prev. Index
Groundings (55)	46	84%	66%	7.9
Collisions (17)	15	88%	79%	8.9
Rammings (6)	6	100%	65%	6.5
Overall Rating	67	86%	69%	8.0

(2) SPECIFIC ISSUES

Better able to detect collision threat than with manual monitoring:

C-1, 2, 3, 4, 5, 7, 8, 11, 16; R-2, 5, 6.

Better able to detect threat of grounding than with manual monitoring:

G-1, 2, 3, 4, 8, 10, 11, 13, 14, 17, 18, 20, 21, 24, 25, 26, 27, 29, 35, 38, 39, 41, 42, 44, 46, 51, 53, 54, 55.

Accuracy still not good enough (1/4 mi):

R-4; G-7, 26, 31.

(3) HISTOGRAM OF SCORES

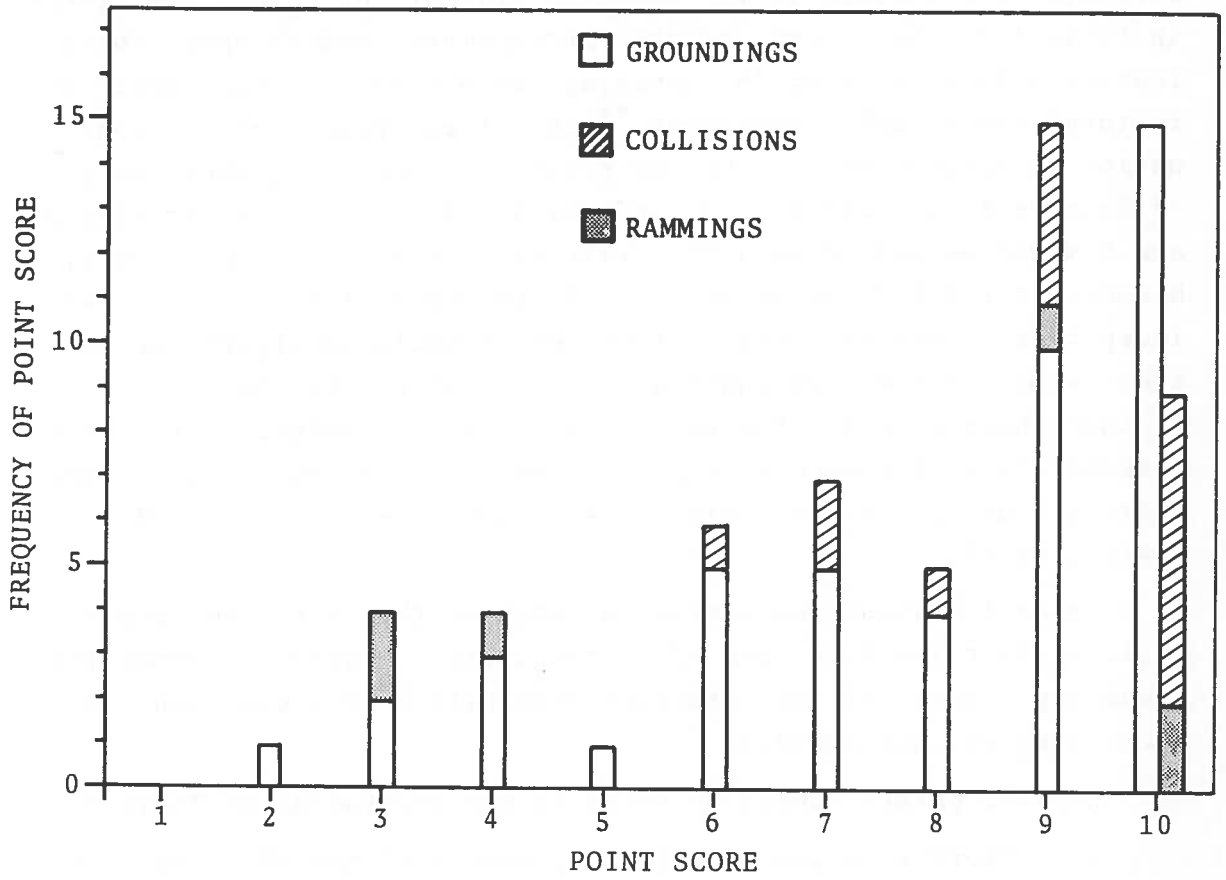

I.3 SYSTEM EVALUATION

Out of 29 systems initially chosen for evaluation, 13 were screened out, leaving 16 for detailed evaluation.* They are listed in Table I-3. Since some of them incorporate several operational features, care is taken in combining the scores. If two operational features are mutually dependent,** the effectiveness of the combination is assumed here to be the greater of the two numbers (e.g., if feature A was scored as 4, and feature B as 7, a system using A and B would be scored as a 7). This is a conservative procedure, because it tends to estimate low. If two operational features are independent, then the total effectiveness would be higher, because there would be two opportunities for prevention. If the condition of independence holds, the effectiveness is determined by the OR-ed possibility of two events (e.g., if feature A was scored as 4, and feature B as 7, a system using A and B would be scored as $7+4 - 7 \times 4 / 10$, or 8).

Table I-4 shows the scores for each of the 16 systems evaluated against the data base of 78 casualties. Table I-5 shows the resulting scores for the potential probability of prevention for each category, and overall.

Several points should be noted in the derivation of Table I-4:

- a. There were two groundings (numbers 41 and 49) where the passport system would have provided assistance not covered by the operational features;
- b. The Baseline System assumed no LORAN-C coverage in Puerto Rico and the Virgin Islands (these are indicated with a check (√));
- c. Navigation Alert and Automatic Monitoring likewise get no LORAN-C navigation information in Puerto Rico and the Virgin Islands.

The scores in Tables I-4 and I-5 do not account for the fact that the baseline system will be in effect by 1985. To account for this, the scores of each system are OR-ed with the baseline system

*In Section 5, 18 promising systems are discussed rather than 16; this is because there are three different surveillance systems considered.

**The following pairings of operational features are mutually dependent: 12-11, 13-12, 14-13, 15-14, 19-18, 19-17, 27-26, 29-28. All others are independent.

scores in Table I-6 (except for Equipment Standards and Navigation Alert, as noted), and the summaries given in Table I-7. The term "potential effectiveness" is used to denote the effectiveness of each system when considered with the Baseline System; it corresponds to the "probability of prevention" in Table I-5 and Section I.2. The potential effectiveness numbers are used in Section 5 to describe the effectiveness of different systems.

Table I-7 shows the potential effectiveness of each system. The potential effectiveness figures do not account, of course, for any lack of availability that comes about from practical considerations. The scores are derived assuming that any equipment is on board every vessel, and that it is working properly.

There are several systems which have potential effectiveness values significantly higher than would be achieved in practice, because only large vessels could afford them: forward-looking and scanning sounders, interrogator/transponders, and collision avoidance equipments could not realistically be required on smaller vessels. In the system description of 5.2, considerations like this are accounted for under "(c) Availability."

In order to account for the fact that smaller vessels cannot afford expensive equipment, it will be assumed for simplicity that small vessels (i.e., less than 10,000 gross tons) will not be equipped with expensive equipment, and that large vessels will (i.e., those greater than 10,000 gross tons). It is assumed, as in Table 5-3, that 38% of the vessels over 1,600 gross tons are tankers; and that of these tankers, 32% are over 10,000 gross tons. The 32% figure is based on a sampling of Boston, Trenton, and New York Port calls in 1975 (U.S. Army Corps of Engineers, 1976). Note that the differences between these figures and those of Table 5-3 reflect the fact that small tankers and barges make more port calls per year, since they make shorter runs. That is, these figures are estimates of the number of port calls, or the population of vessels in a given area at one time, while the cost figures of Table 5-3 are based on estimates of the number of different vessels that would visit the United States in a year's time.

TABLE I-3. SYSTEMS SELECTED FOR DETAILED EVALUATION

System	Section	Operational Features
Baseline System	5.2.1	7,11,12
Intensive and Periodic Training	5.2.7	1
Expanded Traffic Separation	5.2.8	4
Improved Aids-to- Navigation	5.2.9	5,20,23
Improved Pilot Transfer Procedures	5.2.10	6
Equipment Standards	5.2.11	7
Processor-Aided Navigation Alert	5.2.12	11,12,13,14
Depth Alert	5.2.13	17
Scanning Sounder	5.2.14	19
Interrogator/Transponder	5.2.18	21,24,25,28,29
VHF/Transponder	5.2.17	24,28,29
Radar Perimeter Detection	5.2.16	24,25
Collision Avoidance Aid	5.2.15	22,26,27
Vessel Passport System	5.2.2	5,6,7,11,12,31,32
Automatic Monitoring	5.2.3	5,6,7,11,12,31,32,34
Surveillance	5.2.4-6	5,6,7,11,12,31,21,34

TABLE I-4. SYSTEM SCORES

GROUNDINGS (1-17)	√																
	1	2	3	4	5	6	7	8	9	10	11	12	13	14	15	16	17
Baseline System	3	9	7			1		6	3	6	1						2
Training	1	2	3	3		2	1		2	5	1	1		1		1	2
Traffic Separation	2									5							
Aids-to-Navigation	1		6			5	9				9						5
Pilot Transfer	9			9			10					9	8				
Equipment Standards			7				7										
Navigation Alert	3	10	10			7		7	3	7	3						3
Depth Alert	2	8	4		2	1		3	9	3		3	8	2			1
Scanning Sounder	2	8	4		2	1		3	9	3	7	3	8	2			7
Interrogator/Transponder																	
VHF/Transponder																	
Radar Perimeter Det.																	
Collision Avoidance																	
Passport System	9	7	6	9		5	10	10		10	9	9	8			4	7
Auto-Monitoring	9	10	9	10		7	10	10	10	10	10	10	9	8		4	7
Surveillance Systems	9	10	9	10		7	10	10	10	10	10	10	9	8		4	7

TABLE I-4. SYSTEM SCORES (Continued)

	18	19	20	21	22	23	24	25	26	27	28	29	30	31	32	33	34
GROUNDINGS (18-34)																	
Baseline System			7	9	3	10					9	7					
Training			3	2		4	2	2		1	2	3	3	1	1		1
Traffic Separation																	
Aids-to-Navigation	4				9	9	10				5			1			
Pilot Transfer	7					8								7			
Equipment Standards			10	9*	3												
Navigation Alert			8	10	3	10	6				9	10					
Depth Alert		2	5	3	4	3					3	9		2	3		
Scanning Sounder		2	5	3	4	3	2			7	3	9		6	10		
Interrogator/Transponder																	
VHF/Transponder																	
Radar Perimeter Det.																	
Collision Avoidance																	
Passport System	8		10	9	9	10	10		10		6	6		7	8		3
Auto-Monitoring	8		10	9	7	10	10	6	10		9	9		7	8		10
Surveillance Systems	9		10	9	7	10	10	6	10	9	9	9	6	8	8		10

*Included in Baseline System

TABLE I-4. SYSTEM SCORES (Continued)

	35	36	37	38	39	40	41	42	43	44	45	46	47	48	49	50	51
GROUNDINGS (35-51)																	
Baseline System	6	8	10						8	7		4	7				
Training	7	1		1	4	4	2	4	2	1	3	2	3				
Traffic Separation										6							
Aids-to-Navigation	8	9			10			2	10	2		10	2				
Pilot Transfer		10		9												8	9
Equipment Standards	2		6*					8									
Navigation Alert	8	9	10				2		8	10		8	9				
Depth Alert		8		1			6	9	6	4			8	4	6		
Scanning Sounder		8		1	10		6	9	6	4	4		8	4	6		
Interrogator/Transponder																	
VHF/Transponder																	
Radar Perimeter Det.																	
Collision Avoidance																	
Passport System	8	10	6	10	10	2	7**	8	10	2		10	2		10**	8	9
Auto-Monitoring	10	10	8	10	10	2	6	8	10	9		10	10		10	8	10
Surveillance Systems	10	10	8	10	10	2	6	10	10	9	7	10	10		10	8	10

*Included in Baseline System.

**Considerations other than operational features determine the score.

TABLE I-4. SYSTEM SCORES (Continued)

GROUNDINGS (52-55)	√				
	52	53	54	55	
Baseline System	2	4			
Training	1	1	2	2	
Traffic Separation					
Aids-to-Navigation		10			
Pilot Transfer		10		7	
Equipment Standards					
Navigation Alert	7	9	10		
Depth Alert					
Scanning Sounder	8	6			
Interrogator/Transponder					
VHF/Transponder					
Radar Perimeter Det.					
Collision Avoidance					
Passport System		10		7	
Auto-Monitoring	3	10	7	7	
Surveillance Systems	3	10	7	7	

TABLE I-4. SYSTEM SCORES (Continued)

COLLISIONS (1-17)	1	2	3	4	5	6	7	8	9	10	11	12	13	14	14	14	16	17
Baseline System			9											3				
Training	3		3	2	4	3	3	3			2	2	2	2	2	2	3	1
Traffic Separation										9		7						9
Aids-to-Navigation																		
Pilot Transfer			3	7										9				
Equipment Standards			9*															
Navigation Alert			6											3				
Depth Alert																		
Scanning Sounder																		
Interrogator/Transponder	6	9	10	6	8		9	5	9	7	4	10		8	9	9		
VHF/Transponder	6	9	9		7		6	3	9	4	4	10		8	9	8		
Radar Perimeter Det.		9	10	6	4		9	3	2	1		4		3	9	8		
Collision Avoidance	9	9	10	6	5		9	10	6	5	6	7		7	10	7		
Passport System				7									7	9				
Auto-Monitoring	10	9	10	7	9		9	10	10	10	10	8	7	9	10	10		
Surveillance Systems	10	9	10	7	9		9	10	10	10	10	8	7	9	10	10		

*Included in Baseline System.

TABLE I-4. SYSTEM SCORES (Continued)

RAMMINGS (1-6)	1	2	3	4	5	6														
Baseline System		9		1	10	7														
Training	7		1			2														
Traffic Separation																				
Aids-to-Navigation		9			10	10														
Pilot Transfer																				
Equipment Standards																				
Navigation Alert		9		4	10	9														
Depth Alert																				
Scanning Sounder																				
Interrogator/Transponder																				
VHF/Transponder																				
Radar Perimeter Det.		7		9	10	10														
Collision Avoidance		7		9	10	10														
Passport System		9			10	10														
Auto-Monitoring	4	10	3	3	9	10														
Surveillance Systems	4	10	3	3	9	10														

TABLE I-5. SUMMARY OF SYSTEM SCORES (BASELINE NOT INCLUDED)

GROUNDINGS	NO. OF CASES	% OF CASES	POINT SCORE	SPI	PROB. OF PREVENTION
Baseline System	24	44	139	5.6	25%
Training	41	75	90	2.2	16%
Traffic Separation	3	5	13	4.3	2%
Aids-to-Navigation	21	38	136	6.5	25%
Pilot Transfer	14	25	120	8.6	22%
Equipment Standards	8	15	52	6.5	9%
Navigation Alert	27	49	199	7.4	36%
Depth Alert	30	55	132	4.4	24%
Scanning Sounder	37	67	143	5.2	35%
Interrogator/Transponder					
VHF/Transponder					
Radar Perimeter Det.					
Collision Avoidance					
Passport System	43	78	327	7.6	59%
Auto-Monitoring	47	85	404	8.6	73%
Surveillance Systems	50	91	441	8.8	80%

TABLE I-5. SUMMARY OF SYSTEM SCORES (BASELINE NOT INCLUDED) (Continued)

COLLISIONS	NO. OF CASES	% OF CASES	POINT SCORE	SPI	PROB. OF PREVENTION
Baseline System	2	12	12	6	7%
Training	14	82	35	2.5	21%
Traffic Separation	3	18	25	8.3	15%
Aids-to-Navigation					
Pilot Transfer	3	18	19	6.3	11%
Equipment Standards	1	6	9	9	5%
Navigation Alert	1	6	3	3	2%
Depth Alert					
Scanning Sounder					
Interrogator/Transponder	14	82	109	7.8	64%
VHF/Transponder	13	76	95	7.3	56%
Radar Perimeter Det.	12	71	68	5.7	40%
Collision Avoidance	14	82	106	7.6	62%
Passport System	3	18	23	7.7	14%
Auto-Monitoring	15	88	138	9.4	81%
Surveillance Systems	15	88	138	9.4	81%

TABLE I-5. SUMMARY OF SYSTEM SCORES (BASELINE NOT INCLUDED) (Continued)

RAMMINGS	NO. OF CASES	% OF CASES	POINT SCORE	SPI	PROB. OF PREVENTION
Baseline System	4	67	27	6.8	45%
Training	3	50	10	3.3	17%
Traffic Separation					
Aids-to-Navigation	3	50	29	9.7	48%
Pilot Transfer					
Equipment Standards					
Navigation Alert	4	67	32	8.0	53%
Depth Alert					
Scanning Sounder					
Interrogator/Transponder					
VHF/Transponder					
Radar Perimeter Det.	4	67	36	9.0	60%
Collision Avoidance	4	67	36	9.0	60%
Passport System	3	50	29	9.7	48%
Auto-Monitoring	6	100	39	6.5	65%
Surveillance Systems	6	100	39	6.5	65%

TABLE I-5. SUMMARY OF SYSTEM SCORES (BASELINE NOT INCLUDED) (Continued)

OVERALL	NO. OF CASES	% OF CASES	POINT SCORE	SPI	PROB. OF PREVENTION
Baseline System	30	38	178	5.9	23%
Training	58	75	135	2.3	17%
Traffic Separation	6	8	38	6.3	5%
Aids-to-Navigation	24	31	165	6.9	21%
Pilot Transfer	17	22	139	8.2	18%
Equipment Standards	9	12	61	6.8	8%
Navigation Alert	32	41	234	7.3	30%
Depth Alert	30	38	132	4.4	17%
Scanning Sounder	37	47	193	5.2	25%
Interrogator/Transponder	14	18	109	7.8	14%
VHF/Transponder	13	17	95	7.3	12%
Radar Perimeter Det.	16	21	104	6.5	13%
Collision Avoidance	18	23	142	7.9	18%
Passport System	49	63	379	7.7	49%
Auto-Monitoring	68	87	581	8.5	74%
Surveillance Systems	71	91	608	8.6	78%

TABLE I-6. SYSTEM SCORES WITH BASELINE SYSTEM INCLUDED

GROUNDINGS (1-17)	1	2	3	4	5	6	7	8	9	10	11	12	13	14	15	16	17
Baseline System	3	9	7			1		6	3	6	1						2
Training	4	9	8	3		3	1	6	4	8	1	1	1		1	1	4
Traffic Separation	4	9	7			1		6	3	8	1						2
Aids-to-Navigation	4	9	9			5	9	6	3	6	9						6
Pilot Transfer	9	9	7	9		1	10	6	3	6	1		9	8			2
Equipment Standards	3	10	7			1	7	6	3	6	1						2
Navigation Alert	3	10	10			7		7	3	9	3						4
Depth Alert	4	10	8		2	2		7	9	7	1	3	8	2			3
Scanning Sounder	4	10		2	2			7	9	7	7	3	8	2			7
Interrogator/Transponder	3	9	7			1		6	3	6	1						2
VHF/Transponder	3	9	7			1		6	3	6	1						2
Radar Perimeter Det.	3	9	7			1		6	3	6	1						2
Collision Avoidance	3	9	7			1		6	3	6	1						2
Passport System	9	9	7	9		5	10	10	3	10	9	9	9	8		4	7
Auto-Monitoring	9	10	9	10		7	10	10	10	10	10	10	9	8		4	7
Surveillance Systems	9	10	9	10		7	10	10	10	10	10	10	9	10		4	7

TABLE I-6. SYSTEM SCORES WITH BASELINE SYSTEM INCLUDED (Continued)

GROUNDINGS (18-34)	18	19	20	21	22	23	24	25	26	27	28	29	30	31	32	33	34
Baseline System			7	9	3	10					9	7					
Training			8	9	3	10	2	2		1	9	8	3	1	1		1
Traffic Separation			7	9	3	10					9	7					
Aids-to-Navigation	4		7	9	3	10	9	10			9	8		1			
Pilot Transfer	7		7	9	3	10	8				9	7		7			
Equipment Standards			10	9	3	10					9	7					
Navigation Alert			8	10	3	10					9	10					
Depth Alert		2	8	9	3	10	3				9	10		2	3		
Scanning Sounder		2	9	9	3	10	3	2		3	9	10		6	10		
Interrogator/Transponder			7	9	3	10					9	7					
VHF/Transponder			7	9	3	10					9	7					
Radar Perimeter Det.			7	9	3	10					9	7					
Collision Avoidance			7	9	3	10					9	7					
Passport System	8		10	9	3	10	10		10		9	9		7	8		3
Auto-Monitoring	8		10	9	8	10	10	6	10		10	10		7	8		10
Surveillance Systems	9		10	9	8	10	10	6	10	9	10	10	6	8	8		10

TABLE I-6. SYSTEM SCORES WITH BASELINE SYSTEM INCLUDED (Continued)

GROUNDINGS (35-51)	35	36	37	38	39	40	41	42	43	44	45	46	47	48	49	50	51
Baseline System	6	8	10						8	7		4	7				
Training	9	8	10	1	4	4	2	4	8	7	3	5	8				
Traffic Separation	6	8	10						8	9		4	7				
Aids-to-Navigation	9	9	10		10			2	10	7		10	7				
Pilot Transfer	6	10	10	9					8	7		4	7			8	9
Equipment Standards	6	8	10					8	8	7		4	7				
Navigation Alert	8	9	10				2		8	10		8	9				
Depth Alert	6	10	10	1			6	9	9	8		4	9	4	6		
Scanning Sounder	6	10	10	1	10		6	9	9	8	4	4	9	4	6		
Interrogator/Transponder	6	8	10						8	7		4	7				
VHF/Transponder	6	8	10						8	7		4	7				
Radar Perimeter Det.	6	8	10						8	7		4	7				
Collision Avoidance	6	8	10						8	7		4	7				
Passport System	9	10	10	10	10	2	7	8	10	7		10	7	10	8	9	
Auto-Monitoring	10	10	10	10	10	2	6	8	10	10		10	10	10	8	10	
Surveillance Systems	10	10	10	10	10	2	6	10	10	10	7	10	10	10	8	10	

TABLE I-6. SYSTEM SCORES WITH BASELINE SYSTEM INCLUDED (Continued)

GROUNDINGS (52-55)	52	53	54	55															
Baseline System	2	4																	
Training	3	4	2	2															
Traffic Separation	2	4																	
Aids-to-Navigation	2	10																	
Pilot Transfer	2	10		7															
Equipment Standards	2	4																	
Navigation Alert	7	9	10																
Depth Alert	2	4																	
Scanning Sounder	8	7																	
Interrogator/Transponder	2	4																	
VHF/Transponder	2	4																	
Radar Perimeter Det.	2	4																	
Collision Avoidance	2	4																	
Passport System	2	10		7															
Auto-Monitoring	3	10	7	7															
Surveillance Systems	3	10	7	7															

TABLE I-6. SYSTEM SCORES WITH BASELINE SYSTEM INCLUDED (Continued)

COLLISIONS (1-17)	1	2	3	4	5	6	7	8	9	10	11	12	13	14	15	16	17
Baseline System			9											3			
Training	3		9		2	4	3	3	3		2	2	2	4	2	3	1
Traffic Separation			9							9		7		3			9
Aids-to-Navigation			9											3			
Pilot Transfer			9	7										9			
Equipment Standards			9											3			
Navigation Alert			9											3			
Depth Alert			9											3			
Scanning Sounder			9											3			
Interrogator/Transponder	6	9	10	6	8		9	5	9	7	4	10		8	9	9	
VHF/Transponder	6	9	10		7		6	3	9	7	4	10		8	9	8	
Radar Perimeter Det.		9	10	6	4		9	3	2	1		4		5	9	8	
Collision Avoidance	9	9	10	6	5		9	10	6	5	6	7		8	10	7	
Passport System			9	7									7	9			
Auto-Monitoring	10	9	10	7	9		9	10	10	10	10	8	7	9	10	10	
Surveillance Systems	10	9	10	7	9		9	10	10	10	10	8	7	9	10	10	

TABLE I-6. SYSTEM SCORES WITH BASELINE SYSTEM INCLUDED (Continued)

RAMMINGS (1-6)	1	2	3	4	5	6														
Baseline System		9		1	10	7														
Training	7	9	1	1	10	7														
Traffic Separation		9		1	10	7														
Aids-to-Navigation		10		1	10	10														
Pilot Transfer		9		1	10	7														
Equipment Standards		9		1	10	7														
Navigation Alert		9		4	10	9														
Depth Alert		9		1	10	7														
Scanning Sounder		9		1	10	7														
Interrogator/Transponder		9		1	10	7														
VHF/Transponder		9		1	10	7														
Radar Perimeter Det.		10		9	10	10														
Collision Avoidance		10		9	10	10														
Passport System		10		1	10	10														
Auto-Monitoring	4	10	3	3	9	10														
Surveillance Systems	4	10	3	3	9	10														

TABLE I-7. SUMMARY OF SYSTEM SCORES INCLUDING BASELINE SYSTEM

GROUNDINGS	NO. OF CASES	% OF CASES	POINT SCORE	SPI	POTENTIAL EFFECTIVENESS
Baseline System	24	44	139	5.6	25%
Training	45	82	197	4.4	36%
Traffic Separation	24	44	144	6.0	26%
Aids-to-Navigation	31	56	222	7.2	40%
Pilot Transfer	35	64	244	7.0	44%
Equipment Standards	26	47	158	6.1	29%
Navigation Alert	27	49	199	7.4	36%
Depth Alert	37	67	213	5.8	39%
Scanning Sounder	41	75	263	6.4	48%
Interrogator/Transponder	24	44	139	5.6	25%
VHF/Transponder	24	44	139	5.6	25%
Radar Perimeter Det.	24	44	139	5.6	25%
Collision Avoidance	24	44	139	5.6	25%
Passport System	45	82	360	8.0	65%
Auto-Monitoring	47	85	410	8.7	75%
Surveillance Systems	50	91	437	8.7	79%

TABLE I-7. SUMMARY OF SYSTEM SCORES INCLUDING BASELINE SYSTEM (Continued)

COLLISIONS	NO. OF CASES	% OF CASES	POINT SCORE	SPI	POTENTIAL EFFECTIVENESS
Baseline System	2	12	12	6	7%
Training	14	82	43	3.1	25%
Traffic Separation	5	29	37	7.4	22%
Aids-to-Navigation	2	12	12	6	7%
Pilot Transfer	3	18	25	8.3	15%
Equipment Standards	2	12	12	6	7%
Navigation Alert	2	12	12	6	7%
Depth Alert	2	12	12	6	7%
Scanning Sounder	2	12	12	6	7%
Interrogator/Transponder	14	82	109	7.8	64%
VHF/Transponder	13	76	96	7.4	56%
Radar Perimeter Det.	12	71	70	5.8	41%
Collision Avoidance	14	82	107	7.6	63%
Passport System	4	24	32	8.0	19%
Auto-Monitoring	15	88	138	9.2	81%
Surveillance Systems	15	88	138	9.2	81%

TABLE I-7. SUMMARY OF SYSTEM SCORES INCLUDING BASELINE SYSTEM (Continued)

RAMMINGS	NO. OF CASES	% OF CASES	POINT SCORE	SPI	POTENTIAL EFFECTIVENESS
Baseline System	4	67	27	6.8	45%
Training	6	100	35	5.8	58%
Traffic Separation	4	67	27	6.8	45%
Aids-to-Navigation	4	67	31	7.8	52%
Pilot Transfer	4	67	27	6.8	45%
Equipment Standards	4	67	27	6.8	45%
Navigation Alert	4	67	32	8.0	53%
Depth Alert	4	67	27	6.8	45%
Scanning Sounder	4	67	27	6.8	45%
Interrogator/Transponder	4	67	27	6.8	45%
VHF/Transponder	4	67	27	6.8	45%
Radar Perimeter Det.	4	67	39	9.8	65%
Collision Avoidance	4	67	39	9.8	65%
Passport System	4	67	31	7.8	52%
Auto-Monitoring	6	100	39	9.8	65%
Surveillance Systems	6	100	39	9.8	65%

TABLE I-7. SUMMARY OF SYSTEM SCORES INCLUDING BASELINE SYSTEM (Continued)

OVERALL	NO. OF CASES	% OF CASES	POINT SCORE	SPI	POTENTIAL EFFECTIVENESS
Baseline System	30	38	178	5.9	23%
Training	65	83	275	4.2	35%
Traffic Separation	33	42	208	6.3	27%
Aids-to-Navigation	37	47	265	7.2	34%
Pilot Transfer	42	54	296	7.0	38%
Equipment Standards	32	41	197	6.2	25%
Navigation Alert	33	42	243	7.4	31%
Depth Alert	43	55	252	5.9	32%
Scanning Sounder	47	60	302	6.4	39%
Interrogator/Transponder	42	54	275	6.5	35%
VHF/Transponder	41	52	262	6.4	34%
Radar Perimeter Det.	40	51	248	6.2	32%
Collision Avoidance	42	54	285	6.8	37%
Passport System	53	68	423	8.0	54%
Auto-Monitoring	68	87	587	8.6	75%
Surveillance Systems	71	91	614	8.6	79%

When a mixed population of vessels is navigating in a given area, the probability that collision avoidance equipment will be available in all possible encounters requires some calculation. It is assumed here that collision avoidance aids would only be installed on large tankers; that radar perimeter detection devices would be installed only on small tank vessels and all non-tank vessels, and that interrogator/transponder systems would be installed on all large vessels, with transponders on all vessels. Tables I-8a, b, and c show the numbers used to derive the equipment availability figures for the anti-collision systems. It is assumed that when an equipped vessel meets an unequipped vessel, the availability is 50%. The availability is the sum of the products of the individual rows and columns, summed over all the entries. For example, in Table I-8a the availability of collision avoidance aids is calculated to be:

$$(0.32) (0.12) (100\%) + (0.32) (0.26) (50\%) + (0.32) (0.62) (50\%) + (0.68) (0.12) (50\%) = 22\%.$$

I.4 AN ILLUSTRATION OF THE DETERMINATION OF EFFECTIVENESS MEASURES

In order to show how the effectiveness of the system is derived from the operational features, the scoring details will be worked out for the Aids-to-Navigation System of Section 5.2.9, which incorporates the following operational features:

- 5. Improved Light/Buoy Techniques
- 20. RACONS at Fairway, Traffic Lane Entrances
- 23. RACONS on Oil Platforms.

Table I-9 shows the scores for the operational features and systems associated with some of the casualties where the system score for Aids-to-Navigation was non-zero (not including the Baseline System).

TABLE I-8a. EQUIPMENT AVAILABILITY OF COLLISION AVOIDANCE AIDS

	LT (12%)	ST (26%)	NT (62%)
LT (32%)	100%	50%	50%
ST (68%)	50%	0	0

Availability: 22% (See Section 5.2.15).

TABLE I-8b. EQUIPMENT AVAILABILITY OF RADAR PERIMETER DETECTION DEVICES

	LT (12%)	ST (26%)	NT (62%)
LT (32%)	0	50%	50%
ST (68%)	50%	100%	100%

Availability: 78% (See Section 5.2.16).

TABLE I-8c. EQUIPMENT AVAILABILITY OF INTERROGATOR/TRANSPONDER SYSTEMS

	LT (12%)	ST (26%)	LNT (20%)	SNT (42%)
LT (32%)	100%	50%	100%	50%
ST (68%)	50%	0	50%	0

Availability: 32% (See Section 5.2.18).

TABLE I-9. AN EXAMPLE OF SYSTEM SCORES

Item Scored	R 1	R 2	R 3	R 4	R 5	R 6		G 1	G 3	G 6	G 7	G 11	G 17	G 18	G 23	G 24	G 26
Buoy Improvements - Feature Score									6		9	9					10
RACONS - Feature Score					10	4		1		5	7		4	4	9	9	
RACONS on Oil Platforms - Feature Score - Table I-1		9			10	10											
Aids-to-Navigation - System Score		9			10	10		1	6	5	9	9	4	4	9	9	10
Baseline System Score - Table I-4		9		1	10	7		3	7	1		1	2		10		
Combined System Score - Table I-6		10		1	10	10		4	9	5	9	9	6	4	10	9	10

The probability of prevention for rammings was 48% from Table I-5. This was found by adding the point scores in Table I-4 for Aids-to-Navigation for rammings: 10, 10, and 9 gives 29 points for 3 out of 6 rammings; the SPI is $29/(3 \times 10) = 9.7$, and the probability of prevention is given by $100\% \times 29/(6 \times 10) = 48\%$. The factor of 10 comes from the fact that each point score represents a 10% probability. The overall probability of prevention is found by dividing the total point score for Aids-to-Navigation in Table I-4 by 780, 780 would be a perfect score for the 78 casualties.

When the Baseline System is incorporated into the system assessment, the total system score should reflect the fact that the Baseline System also prevents casualties. The Aids-to-Navigation System is independent of the Baseline System, so the individual scores are "OR-ed" to get the combined score. For example, in column G-3 of Table I-9, the system score was 6, the Baseline System score was 7, and the combined system score was calculated to be 9 ($6+7 - 6 \times 7/10 = 8.8$, or approximately 9). Each individual combined system score must be equal to, or greater than, the Baseline System score, so that the total point score will be also. The effectiveness of each combined system is found by adding up the total point score and dividing by 780, which as before, would be a perfect score. The effectiveness number which results is termed the "potential effectiveness." The word potential denotes

the fact that ideal assumptions of availability and usage are still incorporated in the measure of effectiveness. Potential effectiveness also refers to the partial scores: for example, since a perfect score for rammings would be 60 for 6 rammings, the potential effectiveness for rammings is found by adding the combined system scores of 10, 1, 10, and 10 to get 31/60, or 52%, which is given in Table I-7 and Table 5-6. Overall, the combined system score for Aids-to-Navigation was 265 out of a possible 780, or 34%. This is the number given in Table 5-6 and paragraph g of Section 5.2.9.

The availability of a combined Aids-to-Navigation system was estimated to be 95% in paragraph c of Section 5.2.9. The net effectiveness, defined in Section 5.4.2, is a measure which estimates the effectiveness of a system to prevent accidents over and above the effectiveness of the Baseline System. The formula for net effectiveness is repeated here:

$$NE_S = \frac{A_S \times (PE_S - PE_{BL})}{1 - PE_{BL}}$$

For the example worked out, $A_S = 95\%$, $PE_S = 34\%$, and $PE_{BL} = 23\%$. This gives a net effectiveness for an Aids-to-Navigation System of:

$$NE_S = \frac{(0.95) \times (34\% - 23\%)}{1 - 0.23} = 14\%.$$

That is, if the Baseline System were installed and operating, the addition of an Aids-to-Navigation System could be expected to reduce further groundings, collisions, and rammings by 14%.

I.5 REFERENCES

1. Henry, W.O., "RACONs," Coast Guard Engineers Digest, CG-133, No. 172, pp. 36-41, Summer, 1971.
2. Pollack, M., "An Experimental Investigation of Collision Avoidance System Benefits," Proc. 1st. CAORF Symp., pp. 1-12, 1977.

3. Public Law 92-63, "Bridge-to-Bridge Radio-Telephone Act," 4 August 1971.
4. U.S. Coast Guard, "Navigation Rules, International-Inland," CG-169, 1977.

*U.S. GOVERNMENT PRINTING OFFICE: 1978-700-402/173

500 copies

I-149/I-150