

REPORT NO. UMTA-MA-06-0052-78-4

PARATRANSIT VEHICLE TEST AND EVALUATION
Volume IV: Fuel Economy Tests

L. Wesson
C. Culley
R.L. Anderson

Dynamic Science, Inc.
1850 West Pinnacle Peak Road
Phoenix AZ 85047



JUNE 1978
FINAL REPORT

DOCUMENT IS AVAILABLE TO THE U.S. PUBLIC
THROUGH THE NATIONAL TECHNICAL
INFORMATION SERVICE, SPRINGFIELD,
VIRGINIA 22161

Prepared for
U.S. DEPARTMENT OF TRANSPORTATION
URBAN MASS TRANSPORTATION ADMINISTRATION
Office of Technology Development and Deployment
Washington DC 20590

REPRODUCED BY
**NATIONAL TECHNICAL
INFORMATION SERVICE**
U.S. DEPARTMENT OF COMMERCE
SPRINGFIELD, VA. 22161

NOTICE

This document is disseminated under the sponsorship of the Department of Transportation in the interest of information exchange. The United States Government assumes no liability for its contents or use thereof.

NOTICE

The United States Government does not endorse products or manufacturers. Trade or manufacturers' names appear herein solely because they are considered essential to the object of this report.

1. Report No. UMTA-MA-06-0052-78-4		2. Government Accession No.		3. Recipient's Catalog No. PB295478	
4. Title and Subtitle PARATRANSIT VEHICLE TEST AND EVALUATION Volume IV: Fuel Economy Tests				5. Report Date June 1978	
				6. Performing Organization Code	
7. Author(s) L. Wesson, C. Culley, R. L. Anderson				8. Performing Organization Report No. DOT-TSC-UMTA-77-49, IV	
9. Performing Organization Name and Address Dynamic Science, Inc. (subsidiary of Talley Industries) 1850 West Pinnacle Peak Road Phoenix, Arizona 85047				10. Work Unit No. MA-06-0052(UM824/R8732)	
				11. Contract or Grant No. DOT-TSC-1241-4	
12. Sponsoring Agency Name and Address U. S. Department of Transportation Urban Mass Transportation Administration 400 Seventh Street, S. W. Washington, D. C. 20590				13. Type of Report and Period Covered Final Report Nov. 1976-July 1977	
				14. Sponsoring Agency Code	
15. Supplementary Notes Other volumes in the "Paratransit Vehicle Test and Evaluation" series are: Volume I: Ride Comfort and Quality Tests; Volume II: Acceleration and Interior Measurement; Volume III: Handling; and Volume V: Noise Tests. All of these volumes are available from the National Technical Information Service.					
16. Abstract The vehicles presently available for paratransit service do not cover the full spectrum of required characteristics necessary for public transportation. Therefore, specifications were developed by the U.S. Government for a vehicle specifically for use in paratransit service. Prototype vehicles were manufactured for the Government by two different manufacturers (ASL Engineering and Dutcher Industries). Dynamic Science, Inc., conducted an independent series of tests and evaluations of the two prototype vehicles. The program was structured to provide performance data on the prototypes compared to a baseline vehicle that will be used to upgrade future redesigns. The program consisted of five separate test series: 1) Ride Comfort and Quality; 2) Acceleration and Interior Measurement; 3) Handling; 4) Fuel Economy; and 5) Noise. The results of the program are documented in a five-volume technical report, and each volume corresponds to one of the individual test series. This volume (Volume IV) presents the test procedures and results of the fuel economy tests conducted on the two paratransit prototypes and the baseline test vehicle. The test series determined the fuel economy of the vehicles as they were driven through simulated urban and suburban driving cycles. The relationships between fuel consumption and vehicle speeds were determined and maximum fuel economies were established.					
17. Key Words Energy; Evaluation; Fuel Consumption; Fuel Economy; Fuel Economy Tests; Paratransit; Testing Facilities			18. Distribution Statement Available to the Public through the National Technical Information Service Springfield, Virginia 22161.		
19. Security Classif. (of this report) Unclassified		20. Security Classif. (of this page) Unclassified ;		21. No. of Pages 51	22. Price A04-A01

PREFACE

This final report, Volume IV, summarizes the fuel economy testing on the Paratransit Evaluation and Testing Contract. The program was structured to provide performance data on the prototypes compared to a baseline vehicle that will be used to upgrade future redesigns.

The program was conducted by Dynamic Science, Inc. under Contract DOT-TSC-1241 with the Transportation Systems Center (TSC) of Cambridge, Massachusetts for the Urban Mass Transportation Administration. The contract was technically managed by Mr. Jim Kakatsakis and Mr. Joe Picardi of TSC.

The opinions and findings expressed in this publication are those of the authors and not necessarily those of the Government.

METRIC CONVERSION FACTORS

Approximate Conversions to Metric Measures

Symbol	When You Know	Multiply by	To Find	Symbol
	LENGTH			
in	inches	*2.5	centimeters	cm
ft	feet	30	centimeters	cm
yd	yards	0.9	meters	m
mi	miles	1.6	kilometers	km
	AREA			
in ²	square inches	6.5	square centimeters	cm ²
ft ²	square feet	0.09	square meters	m ²
yd ²	square yards	0.8	square meters	m ²
mi ²	square miles	2.6	square kilometers	km ²
	acres	0.4	hectares	ha
	MASS (weight)			
oz	ounces	28	grams	g
lb	pounds	0.45	kilograms	kg
	short tons (2000 lb)	0.9	tonnes	t
	VOLUME			
tsp	teaspoons	5	milliliters	ml
Tbsp	tablespoons	15	milliliters	ml
fl oz	fluid ounces	30	milliliters	ml
c	cups	0.24	liters	l
pt	pints	0.47	liters	l
qt	quarts	0.95	liters	l
gal	gallons	3.8	liters	l
ft ³	cubic feet	0.03	cubic meters	m ³
yd ³	cubic yards	0.76	cubic meters	m ³
°F	Fahrenheit temperature	5/9 (after subtracting 32)	Celsius temperature	°C

Approximate Conversions from Metric Measures

When You Know	Multiply by	To Find	Symbol	
LENGTH				
millimeters	0.04	inches	in	
centimeters	0.4	inches	in	
meters	3.3	feet	ft	
meters	1.1	yards	yd	
kilometers	0.6	miles	mi	
	AREA			
square centimeters	0.16	square inches	in ²	
square meters	1.2	square yards	yd ²	
square kilometers	0.4	square miles	mi ²	
hectares (10,000 m ²)	2.5	acres	ac	
	MASS (weight)			
grams	0.035	ounces	oz	
kilograms	2.2	pounds	lb	
tonnes (1000 kg)	1.1	short tons	short tons	
	VOLUME			
milliliters	0.03	fluid ounces	fl oz	
liters	2.1	pints	pt	
liters	1.06	quarts	qt	
liters	0.26	gallons	gal	
cubic meters	35	cubic feet	ft ³	
cubic meters	1.3	cubic yards	yd ³	
°C	Celsius temperature	9/5 (then add 32)	Fahrenheit temperature	°F

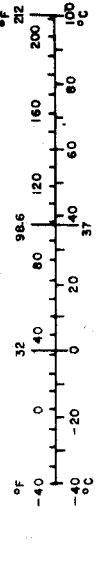
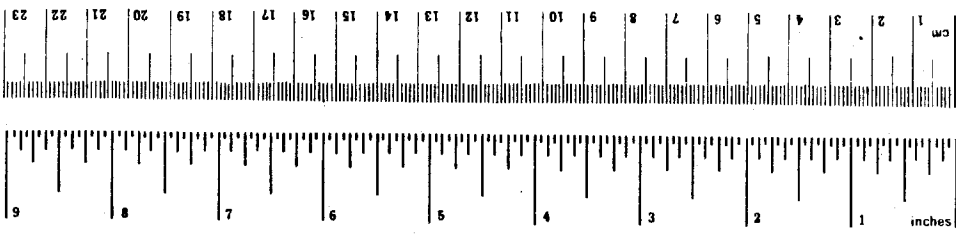

* 1 in. = 2.54 exactly. For other exact conversions and more detailed tables, see NBS Misc. Publ. 286, Units of Weights and Measures, Price \$2.25, SO Catalog No. C73-102-56.

TABLE OF CONTENTS

	<u>Page</u>
1.0 INTRODUCTION	1
2.0 TEST DESCRIPTION	4
2.1 TEST OBJECTIVES	4
2.2 TEST DESIGN	4
2.3 SCOPE OF TEST SERIES.	4
3.0 TEST VEHICLES.	6
3.1 ASL PARATRANSIT VEHICLE	6
3.2 DUTCHER PARATRANSIT VEHICLE	6
3.3 BASELINE TEST VEHICLE	10
3.4 COMPARISON OF BASIC VEHICLE CHARACTERISTICS . .	10
4.0 TEST FACILITIES.	12
5.0 TEST PROCEDURE	15
5.1 TEST INSTRUMENTATION.	15
5.1.1 Required Measurements.	15
5.1.2 Instrumentation Specifications	15
5.1.3 Calibration Procedures	17
5.1.4 Data Acquisition	17
5.2 VEHICLE PREPARATION	18
5.2.1 Instrumentation Installation	18
5.2.2 Vehicle Loading.	22
5.3 TEST CONDUCT.	30
5.3.1 General Test Conditions.	30
5.3.2 Urban Tests.	31

TABLE OF CONTENTS (CONTD)

	<u>Page</u>
5.3.3 Suburban Tests	31
5.3.4 Constant Speed Tests	31
6.0 TEST RESULTS	34

LIST OF ILLUSTRATIONS

<u>Figure</u>		<u>Page</u>
1	Test Vehicles Left-to-Right: Dutcher PTV, ASL PTV, Chevrolet Nova	7
2	ASL Paratransit Vehicle	8
3	Dutcher Paratransit Vehicle	9
4	Aerial View of Dynamic Science Deer Valley Facility.	13
5	Course Layout for Fuel Economy.	14
6	Installation Schematic of Fuel Monitoring Instrumentation in Nova Baseline Vehicle.	19
7	Flow Transducer Installation in Nova.	20
8	Thermocouple Installation in Nova	21
9	Installation Schematic of Fuel Monitoring System in Dutcher Prototype	22
10	Flow Transducer and Thermocouple Installation in Dutcher Prototype.	23
11	Installation Schematic of Fuel Monitoring System in ASL Prototype	24
12	Fuel Monitoring System Installed in ASL Prototype	25
13	Installation of Fuel Flow Transducer in ASL Prototype	26
14	Typical Fifth Wheel Installation.	27
15	Typical Installation of Visual Displays	28

LIST OF ILLUSTRATIONS (CONTD)

<u>Figure</u>		<u>Page</u>
16	Constant Speed Fuel Economy for the Nova Baseline Vehicle.	39
17	Constant Speed Fuel Economy for the ASL Prototype	40
18	Constant Speed Fuel Economy for the Dutcher Prototype	41
19	Comparison of Constant Speed Fuel Economy . . .	42

LIST OF TABLES

<u>Table</u>		<u>Page</u>
1	Fuel Economy Test Cycles.	4
2	Fuel Economy Test Series.	5
3	Basic Test Vehicle Characteristics.	11
4	Fuel Economy Instrumentation List	16
5	Fuel Economy Test Loading Conditions.	29
6	Prescribed Vehicle Weights for Fuel Economy Testing	29
7	Properties of Test Fuel	30
8	Urban Test Schedule	32
9	Suburban Test Schedule.	33
10	Average Test Time for Constant Speed Course . .	33
11	Summary of Fuel Economy Performance for the Nova (Baseline)	35
12	Summary of Fuel Economy Performance for the ASL Prototype	36
13	Summary of Fuel Economy Performance for the Dutcher Prototype	37
14	Comparison of Fuel Economy Performance.	38

1.0 INTRODUCTION

The paratransit mode of transportation provides an alternative between transit in privately owned and operated vehicles and scheduled mass transit systems. Paratransit includes such systems as dial-a-ride, taxi, and jitney service. It is of vital importance to people without individual cars or ready access to regular mass transit and to people of limited mobility. The vehicles presently available for paratransit service, however, do not cover the full spectrum of required characteristics. They are slightly modified versions of vehicles designed for different purposes. As such, they are not as efficient in their operation nor as easy to enter and exit as is desirable in this type of transportation.

Therefore, the Urban Mass Transportation Administration (UMTA), working through the Transportation Systems Center (TSC), developed specifications for a vehicle specifically for use in paratransit which combines a number of desirable features without compromising important performance parameters. Prototype vehicles were manufactured for UMTA by two different manufacturers (ASL Engineering and Dutcher Industries) according to these specifications. The primary features of the vehicles are a low pollution, quiet, efficient propulsion system combined with a body designed for the comfort and convenience of both the passengers and driver. The vehicles include provisions for easy ingress and egress for the general public as well as the elderly and handicapped, including the easy ingress/egress and accommodation of a wheelchair passenger.

Dynamic Science, Inc. was selected by UMTA to conduct an independent series of tests and evaluations of the two prototype paratransit vehicles (PTV). These tests were designed to provide

additional information on the ride quality and comfort, fuel economy, performance and handling characteristics of the two vehicles. A compact passenger car (Chevrolet Nova) was utilized as a baseline test vehicle throughout the test series to furnish comparative data for the evaluations.

The paratransit vehicle testing and evaluation program consisted of six major tasks. The first task consisted of initial vehicle inspection, test preparation, and driver familiarization efforts conducted upon delivery of the vehicles to the Dynamic Science test facility. The remaining five tasks consisted of conducting and evaluating the results of five separate test series. These series were:

- Ride Comfort and Quality Test Series which measured the ride characteristics of the test vehicles to determine if and how well they satisfy accepted standards of ride quality.
- Acceleration and Interior Measurement Test Series which determined the acceleration characteristics and available interior space of the vehicles in order to evaluate their suitability for urban paratransit use.
- Handling Test Series which determined the steering and handling characteristics of the PTVs and allowed their characteristics to be compared with those of the baseline test vehicle.
- Fuel Economy Test Series which obtained fuel economy data for the PTVs under actual road conditions with various driving cycles.
- Noise Test Series which measured the acoustic noise generated by the vehicles and the noise environment inside the passenger and driver compartments.

The Paratransit Test and Evaluation Program is documented in five separate volumes as follows:

Volume 1 - Ride Comfort and Quality Tests

Volume 2 - Acceleration and Interior Measurement Tests

Volume 3 - Handling Tests

Volume 4 - Fuel Economy Tests

Volume 5 - Noise Tests

This volume (Volume 4) presents the test procedures and results of the fuel economy tests conducted on the two PTV prototypes and the baseline test vehicle.

2.0 TEST DESCRIPTION

2.1 TEST OBJECTIVES

The fuel economy tests were conducted to obtain fuel economy data for the paratransit vehicles under actual road driving conditions.

2.2 TEST DESIGN

The tests were designed to determine on-the-road fuel economy data for the two paratransit prototypes (one from ASL engineering and the other from Dutcher Industries) and a baseline vehicle (1977 Chevrolet Nova 6). The vehicles were driven through simulated urban and suburban driving cycles (as defined in SAE J1082) as well as constant speed courses under various loading conditions. The driving test cycles are summarized in Table 1.

TABLE 1. FUEL ECONOMY TEST CYCLES

Course	Distance (miles)	Test Speed (mph)
Urban	2.0	Variable, average = 15.6
Suburban	5.2	Variable, average = 41.1
Constant Speed	4.0	10, 20, 30, 40, 50, and speed of maximum fuel economy*

*Speed was determined graphically from other constant speed tests.

2.3 SCOPE OF TEST SERIES

A summary of the test conditions is presented in Table 2. The fuel economy test series consisted of 11 test conditions on each prototype paratransit vehicle and 8 test conditions on the

TABLE 2. FUEL ECONOMY TEST SERIES

<u>Vehicle</u>	<u>Course</u>	<u>Test Conditions by Load</u>	<u>Loading Conditions</u>	<u>Test Runs</u>
Paratransit	Urban	1 Variable Velocity	3	6
	Suburban	1 Variable Velocity	2	6
	Constant Speed	6 Constant Velocities	1	6
Baseline	Urban	1 Variable Velocity	1	6
	Surburban	1 Variable Velocity	1	6
	Constant Speed	6 Constant Velocities	1	6

baseline vehicle. There were 6 repeated runs for each test condition, leading to a total of 66 runs for each PTV and 48 runs for the baseline vehicle.

3.0 TEST VEHICLES

The test vehicles consisted of two prototype paratransit vehicles (one manufactured by ASL Engineering and the other by Dutcher Industries) and one baseline vehicle (Chevrolet Nova). These vehicles are shown in Figure 1.

3.1 ASL PARATRANSIT VEHICLE

The ASL PTV (Figure 2) is a front engine, front drive vehicle which can accommodate a maximum of five seated passengers or three seated passengers plus a wheelchair. Ingress/egress is accomplished through remotely operated sliding doors on each side of the vehicle. An electrically powered loading ramp may be extended on the right side of the vehicle to permit unassisted ingress and egress for wheelchair passengers.

The driver's compartment is separated from the passenger compartment by a bullet-resistant partition. An intercom system is provided for communication between the two compartments. All seating positions are equipped with belt restraints and a restraint system is also provided to fasten the wheelchair securely to the vehicle.

3.2 DUTCHER PARATRANSIT VEHICLE

The Dutcher PTV (Figure 3) is a rear engine, rear drive vehicle which also accommodates five seated passengers or four seated passengers plus a wheelchair. Hydraulically actuated bifold doors on each side of the vehicle permit passenger ingress and egress. An electrically powered loading ramp extending on the right side of the vehicle allows wheelchair ingress and egress.

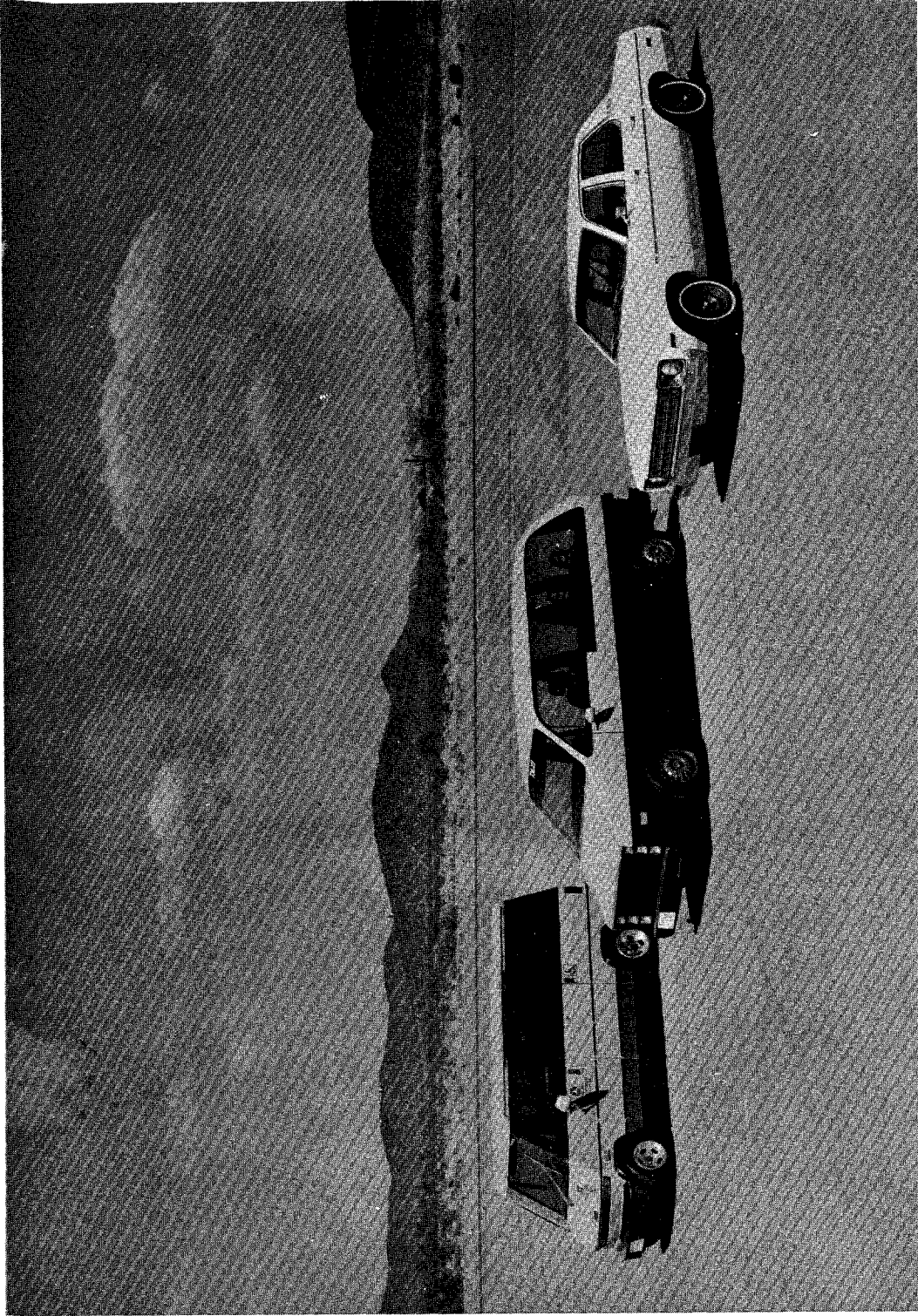

Figure 1. Test Vehicles Left-to-Right: Dutcher PTV, ASL PTV, Chevrolet Nova.

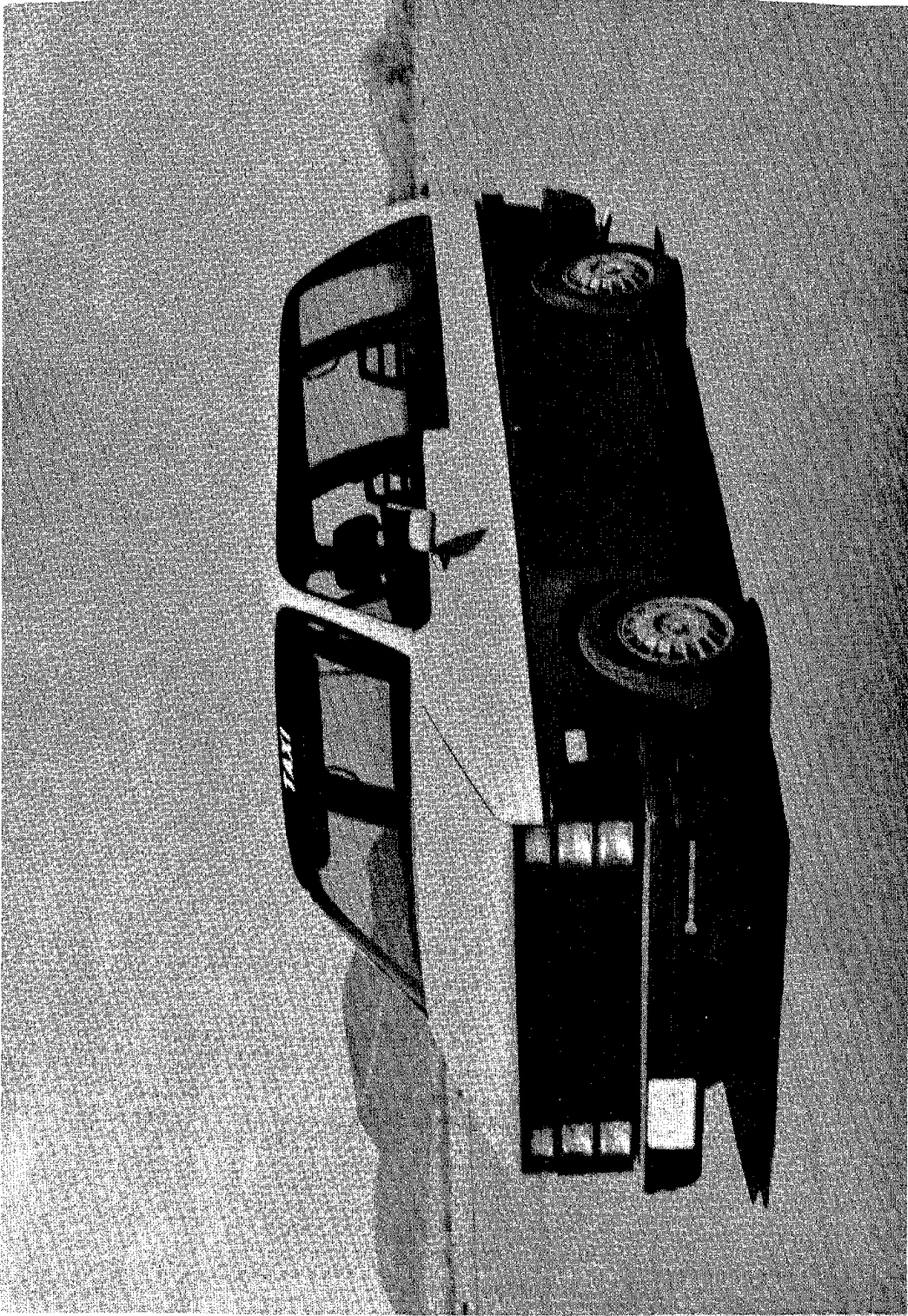

Figure 2. ASL Paratransit Vehicle.

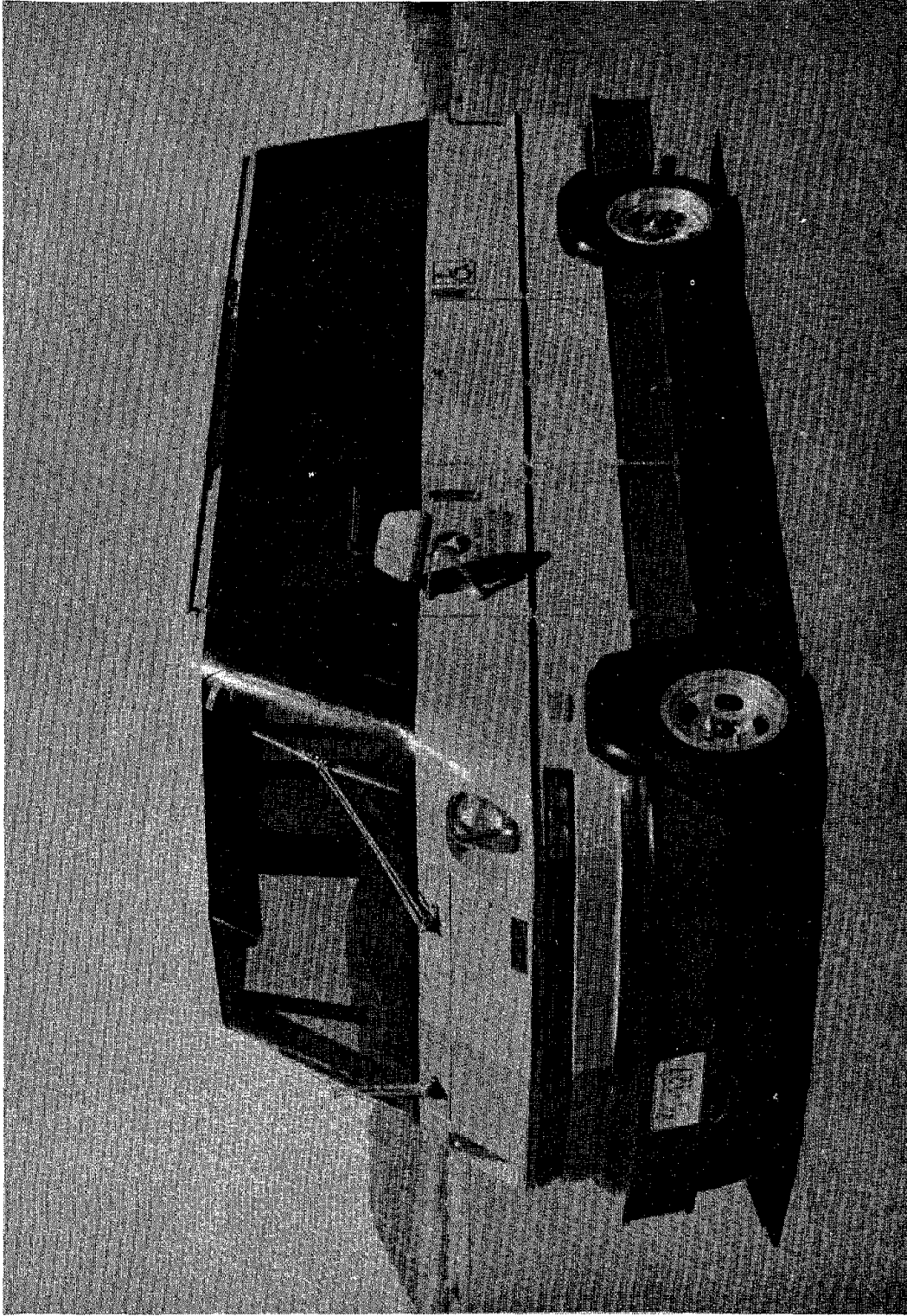

Figure 3. Dutcher Paratransit Vehicle.

As in the ASL PTV, the Dutcher PTV contains a driver compartment which is completely separated from the passenger compartment by a transparent partition. Communication between passengers and driver is accomplished through an intercom system. Restraints are provided for all seating positions and for the wheelchair.

3.3 BASELINE TEST VEHICLE

The baseline test vehicle which was used for comparative evaluation of the PTV test results was a 1977 Chevrolet Nova 6. The criteria for the selection of the baseline vehicle were:

- Compact Size
- 4-Door Passenger Car
- 6-Cylinder Engine
- Automatic Transmission
- Air Conditioning System
- Radial Tires
- Weight, Width, and Length Comparable to the Paratransit Vehicle
- Mileage Less Than 5,000 miles.

The Nova was selected because it fulfills all of the above requirements and, in addition, is more prevalent and more commonly known than any of the other vehicles which met the criteria.

3.4 COMPARISON OF BASIC VEHICLE CHARACTERISTICS

The basic test vehicle characteristics are listed in Table 3. The characteristics of the two PTV vehicles are similar in most instances. The major differences between the two vehicles lie in the engine location/drive configuration and in the front-to-rear weight ratio (1.59 for the ASL and 0.60 for the Dutcher).

TABLE 3. BASIC TEST VEHICLE CHARACTERISTICS

Vehicle Parameter	ASL PTV	Dutcher PTV	Nova (Baseline)
1. Dimensions			
Height (in.)	70.8	80.1	55.1
Width (in.)	72.5	72.8	73
Length (in.)	184	172.5	197.1
Wheelbase (in.)	108.3	106.8	111.4
Track			
- Front (in.)	63.4	63.5	61
- Rear (in.)	63.2	61.9	59.3
2. Weight			
Curb Weight (lb)	3510	3021	3450
- Front Rear Ratio	1.59	0.60	1.23
3. Minimum Turning			
Diameter (ft)	37.5	33.8	40.2
4. Engine			
Location	Front	Rear	Front
No. of Cylinders	4	4	6
Displacement (in. ³)	114.5	120.3	250
Horsepower	95	86	110
Compression Ratio	8:1	7.6:1	8.25:1
5. Transmission			
Automatic/Manual	Automatic	Automatic	Automatic
No. of Forward Speeds	3	3	3
6. Brakes			
Power/Manual	Power	Manual	Power
Front	Disc	Disc	Disc
Rear	Drum	Drum	Drum
7. Tire Size	ER78-14	Front BR78-13 Rear ER78-14	FR78-14
8. Steering			
Power/Manual	Power	Manual	Power
Type	Rack & Pinion	Rack & Pinion	Standard
9. Drive			
Front/Rear	Front	Rear	Rear
Ratio	4.11	4.57	2.73
10. Fuel Capacity (gal)	15	15	21

4.0 TEST FACILITIES

The fuel economy testing was performed at the Dynamic Science Deer Valley Facility, shown in Figure 4. All of the tests were conducted on the two-mile oval which is a minimum two lanes wide (fourteen feet each) throughout. The inside lane was utilized since it has no appreciable cross slope. Its surface is of asphaltic concrete with no perceptible bumps or dips due to overlapping paving strips. The pavement grade of the straightaways is less than 1 percent.

The course layout for the fuel economy tests is illustrated in Figure 5. The courses were marked using ground supported posts. They extended at least 4 feet above the ground and had the mileage marked on them so that they could be easily read from the test vehicle while it was traversing the course. The posts appeared at the 0.0, 0.2, 0.3, 0.5, 0.7, 0.8, 1.0, 1.2, 1.3, 1.5, 1.7, 1.8, 2.0, 2.6, 3.3, 4.0, and 5.2 mileage positions. Each post position was within 5 feet of the desired position going both ways around the track.

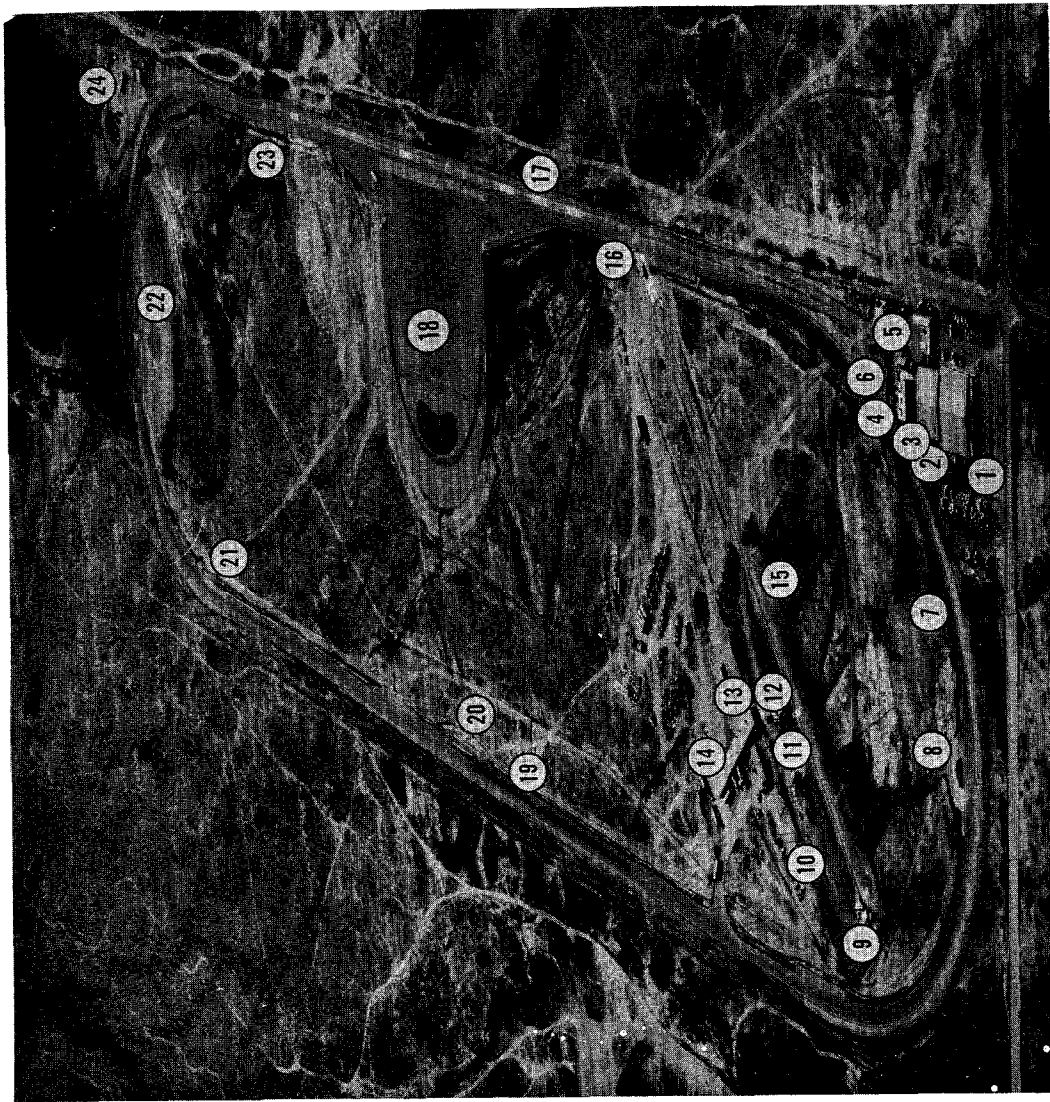

1. ENGINEERING/ADMINISTRATION CENTER
2. MECHANICAL/INSTRUMENTATION SHOPS
3. DUMMY CALIBRATION LABORATORY
4. GARAGE/MAINTENANCE SHOP
5. ENVIRONMENTAL CHAMBER
6. STATIC CRUSH FACILITY
7. TWO-MILE OVAL
8. TURNAROUND (TYPICAL OF TWO)
9. BARRIER IMPACT FACILITY
10. DROP TOWER/SLED TEST FACILITY
11. CENTRAL DATA ACQUISITION AND CONTROL STATION
12. PENDULUM FACILITY
13. NONMETALLICS LABORATORY
14. TEST SERVICE FACILITY
15. VEHICLE-TO-VEHICLE TEST FACILITY
16. ROLLOVER TEST FACILITY
17. RIDE QUALITY COURSE
18. SKID PAD
19. HIGH AND LOW SKID NUMBER BRAKING LANES
20. SALT WATER TROUGH
21. BELGIAN BLOCK
22. PARKING BRAKE TEST RAMP
23. PULL-OFF AREA (TYPICAL OF THIRTEEN)
24. BALLISTIC TEST RANGE

Figure 4. Aerial View of Dynamic Science Deer Valley Facility.

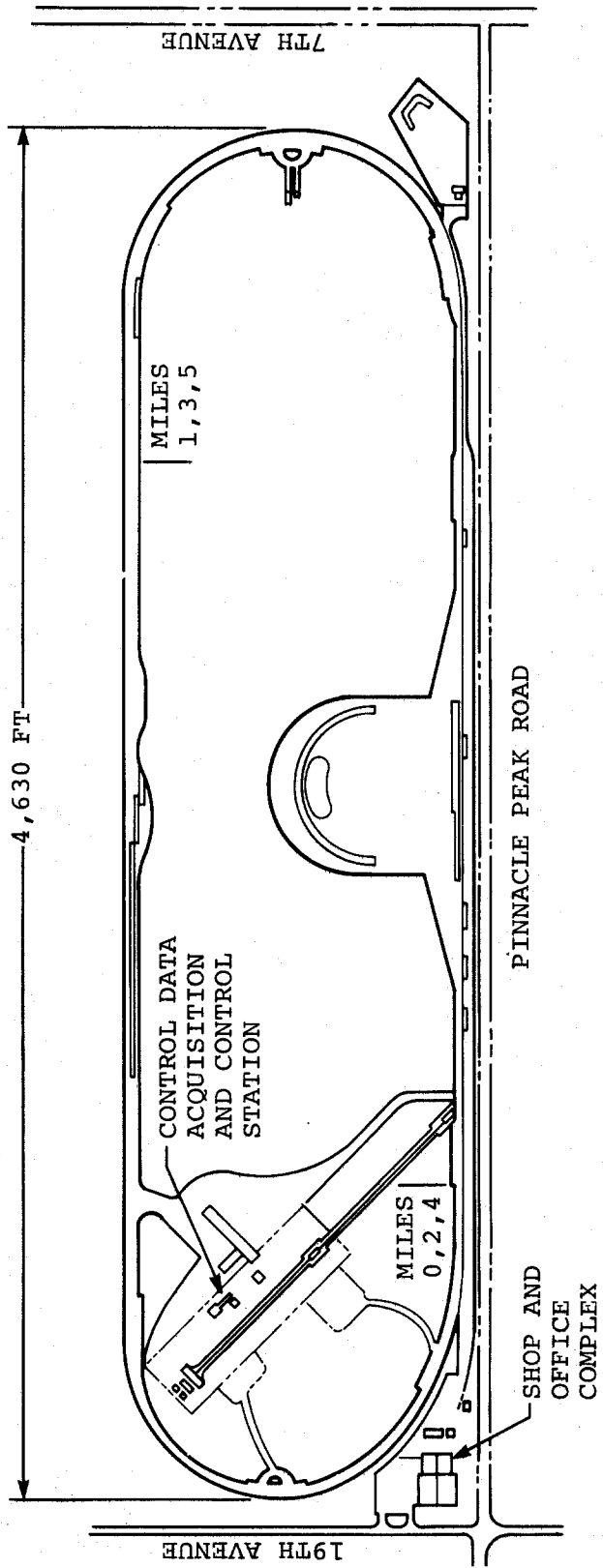

Figure 5. Course Layout for Fuel Economy.

5.0 TEST PROCEDURE

5.1 TEST INSTRUMENTATION

5.1.1 Required Measurements

The primary variables measured during the fuel economy testing were:

1. Vehicle velocity
2. Fuel consumption
3. Fuel temperature
4. Elapsed time.

5.1.2 Instrumentation Specifications

The instrumentation specifications and requirements for the testing are presented in Table 4.

A Labeco fifth wheel was used to measure vehicle velocity. The output of the fifth wheel was inputted into a Labeco DD1.1 speedometer for visual display of velocity.

Fuel consumption was determined from a Fluidyne flowmeter system and fuel temperature was measured with a thermocouple. These instruments were read out on visual displays. Elapsed time was determined by means of a stopwatch.

An Ammco manometer mounted on the vehicle in the driver's field of view was used to monitor the vehicle acceleration during the driving of the urban and suburban cycles.

Ambient conditions of temperature, barometric pressure, and wind speed were measured at the Central Data Acquisition and Control Station (see Figure 5).

TABLE 4. FUEL ECONOMY INSTRUMENTATION LIST

Measurand	Transducer Description	Manufacturer and Model	Range	Accuracy
<u>Vehicle Data</u>				
Velocity	Fifth Wheel	Labeco TT481 DD1.1 Readout	100 mph	±.5mph F.S.*
Fuel Consumption	Positive Displacement Flowmeter System with Digital Readout	Fluidyne Model 1221	.5 to 35 cc/sec	±.5%**
Fuel Temperature	Type T Thermocouple with Precision Digital Readout	Omega	-300 to 700°F	±1°F
Elapsed Time	Stopwatch	Breitling	-	±.05 sec
Acceleration	Manometer	Ammco Model 7375	-32.2 to +15 ft/sec ²	±.5 ft/sec ²
<u>Ambient Data</u>				
Atmospheric Pressure	Barometer	Weather Measure Corporation BM60	25 to 31 in. Hg	.1 in. Hg
Air Temperature	Thermometer	Taylor	-30 to 120°F	±1°
Wind Speed	Wind Velocity System	Sierra Weather Corporation Model 1032	50 mph/360°	±5%

*Full-scale.
**Of reading.

5.1.3 Calibration Procedures

The fifth wheel was calibrated daily using a calibration motor to spin the wheel. The tire pressure was adjusted to obtain the proper calibration values.

The flowmeter system and fuel temperature thermocouple were calibrated at the factory and physically checked in the Dynamic Science Instrumentation Laboratory before their installation in the vehicle.

The manometer installation in the vehicle was checked daily before testing to ascertain that the at-rest position reading was zero.

5.1.4 Data Acquisition

All test data and other pertinent test information was recorded on Test Data Log forms by the test driver. This information included:

- Time and course
- Driver's comments
- Testing decisions (repeating the tests or suspending testing and why)
- Direction traveled around course
- Fuel temperature taken several times during each test run (at vehicle idle periods) and at start and end of each test run.
- Ambient conditions (temperature, barometric pressure, wind velocity) at the start and end of each test run.
- Accumulated time and fuel consumption for each test run.

All data except that pertaining to ambient conditions were read from the visual displays in the test vehicle. Ambient conditions were relayed to the driver upon request from the Central Data Acquisition and Control Station via a two-way radio communications system.

5.2 VEHICLE PREPARATION

The vehicles were prepared for testing by installing the required instrumentation listed in Table 4 and by loading the vehicles to the prescribed loading conditions.

5.2.1 Instrumentation Installation

The fuel flowmeter and fuel temperature thermocouple were installed in the vehicles in such a manner that they did not alter the vehicle operating characteristics. These installations are described in the following paragraphs.

The fuel flow transducer and fuel temperature sensor were installed in the Nova baseline vehicle as illustrated in Figure 6. The regular fuel line between the fuel pump and the carburetor was disconnected. Flexible tubing was used to connect one end of a tee fitting to the fuel pump and the other end of the fitting to the inlet of the flow transducer. The outlet of the flow transducer was connected with tubing to the carburetor. A copper-constantan thermocouple was installed in the tee fitting to measure the gas temperature. Figures 7 and 8 show the flow transducer and thermocouple installations, respectively.

The installation of the fuel monitoring instrumentation in the Dutcher prototype is illustrated in Figure 9. The regular line between the gas tank and fuel pump was disconnected. The thermocouple and flow transducer were installed between the tank and pump using flexible tubing. The Dutcher PTV has a continuous injection system in which the fuel flows constantly and any excess

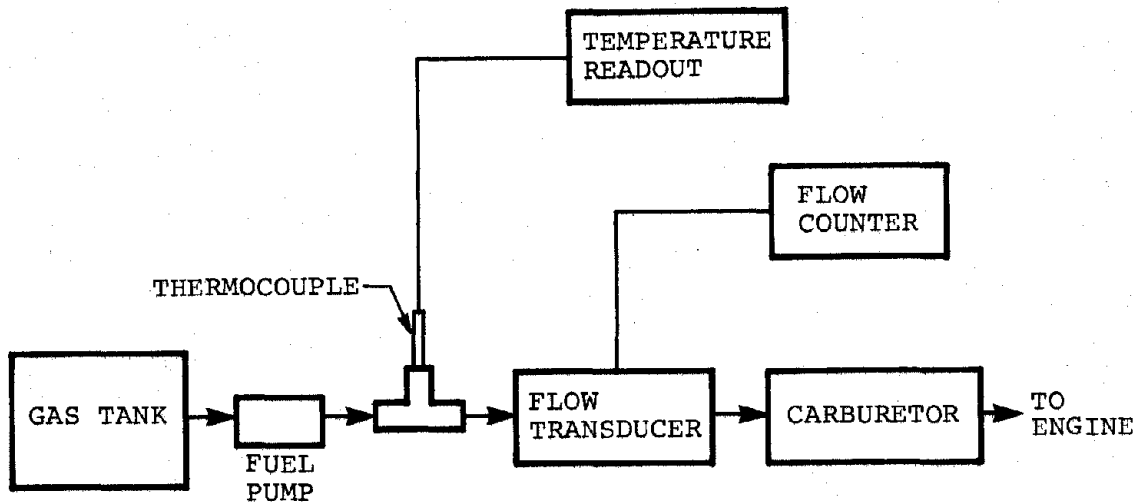

Figure 6. Installation Schematic of Fuel Monitoring Instrumentation in Nova Baseline Vehicle.

fuel is bypassed to the gas tank. To avoid counting the bypassed fuel again, the bypass to the gas tank was diverted to a position downstream of the flow transducer. The actual installation of the instrumentation is shown in Figure 10.

The ASL prototype was first prepared in the same manner as the Dutcher, with the flow transducer installed between the gas tank and the pump and with the bypass diverted downstream of the flowmeter. However, this configuration flooded the engine and made the installation shown in Figure 11 necessary. An auxiliary pump was used to pump the gasoline from the gas tank through the flow transducer into an auxiliary tank. A float valve assembly in the auxiliary tank kept the fuel level in the tank constant so that only that flow used to replenish the auxiliary tank was counted by the flowmeter. The gas going to the continuous injection system was pumped from the auxiliary tank. The bypassed fuel was cooled by a finned, air cooled heat exchanger and routed back into the auxiliary tank. The system as installed in the vehicle is shown in Figures 12 and 13.

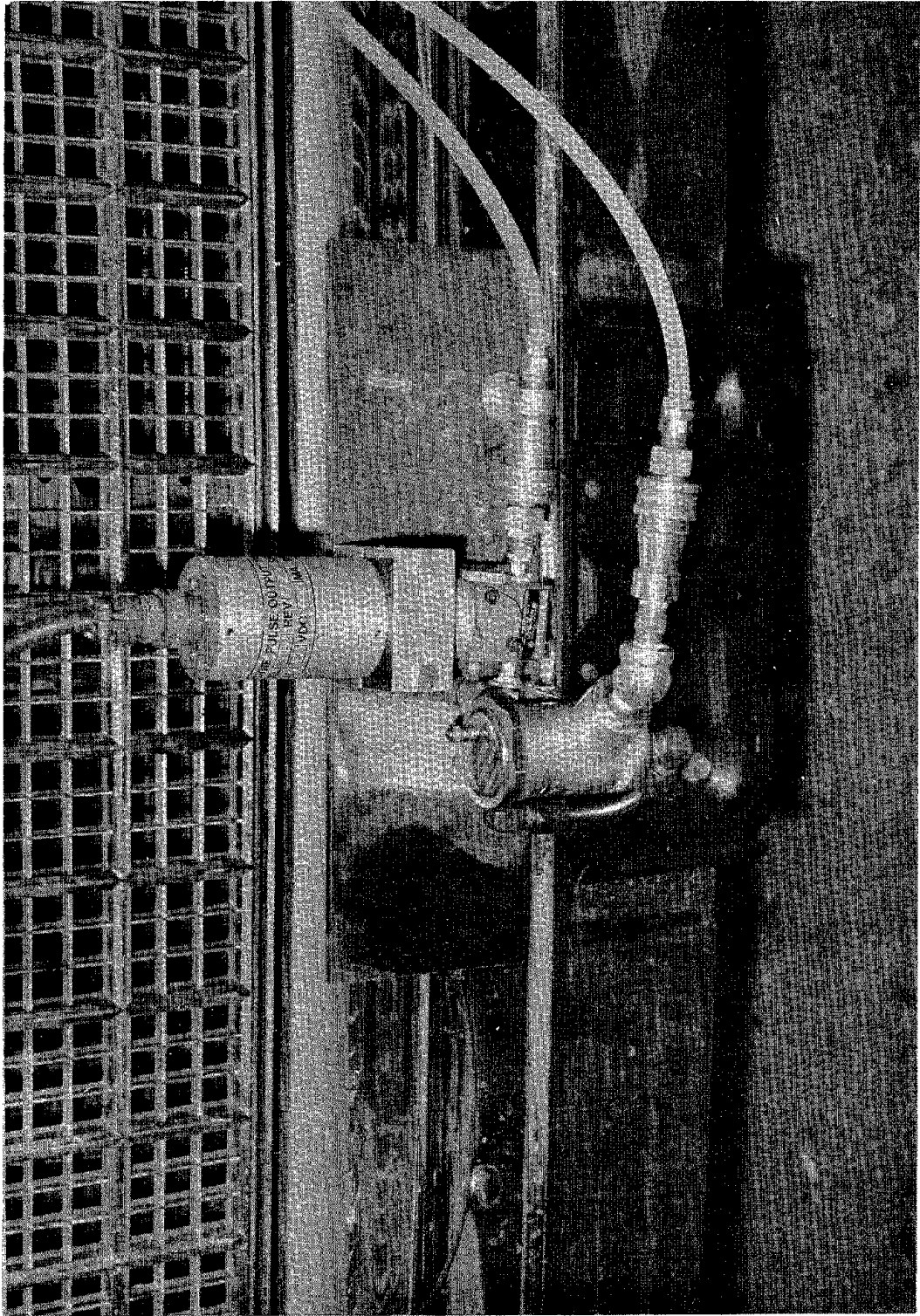

Figure 7. Flow Transducer Installation in Nova.

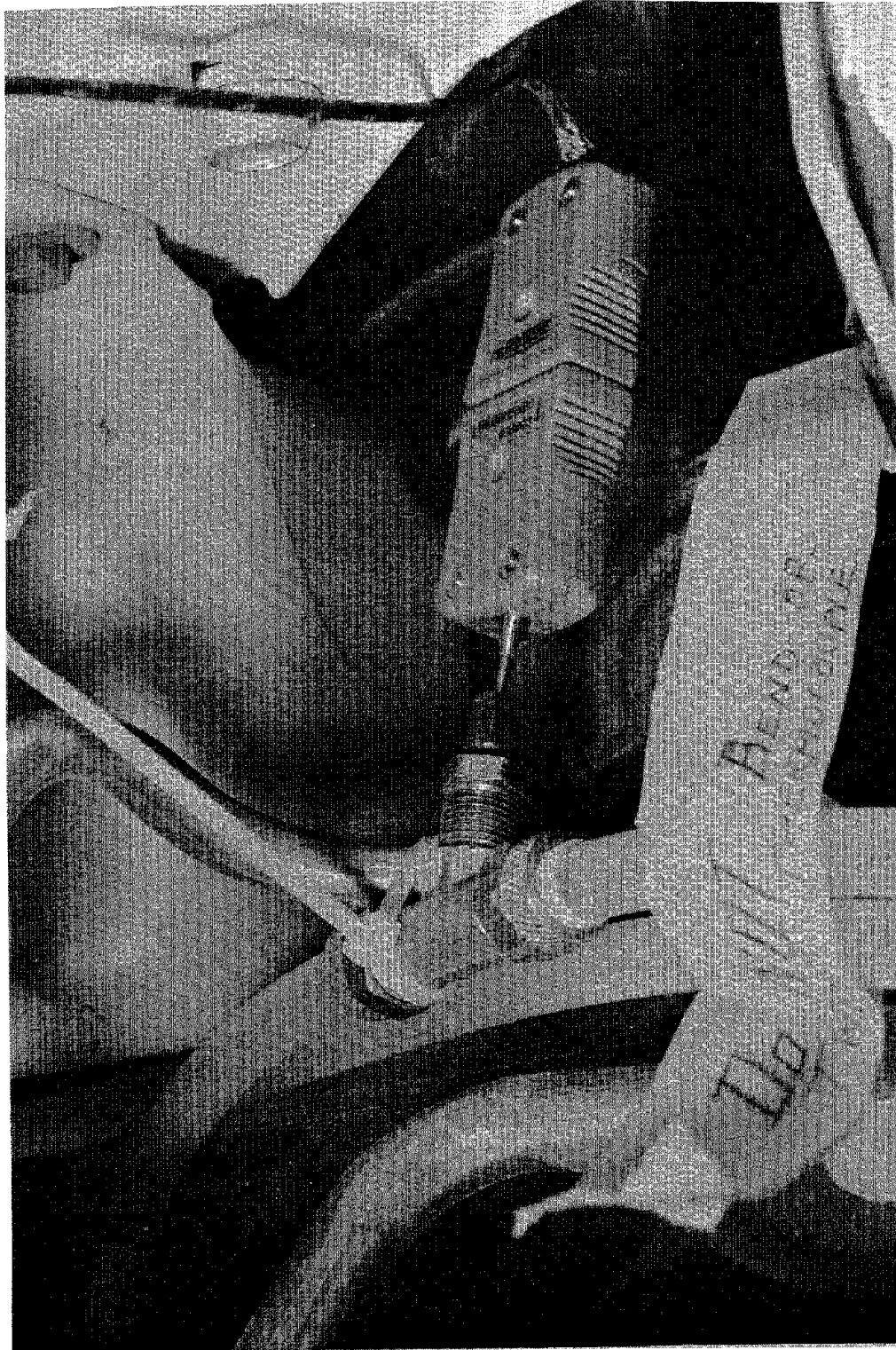

Figure 8. Thermocouple Installation in Nova.

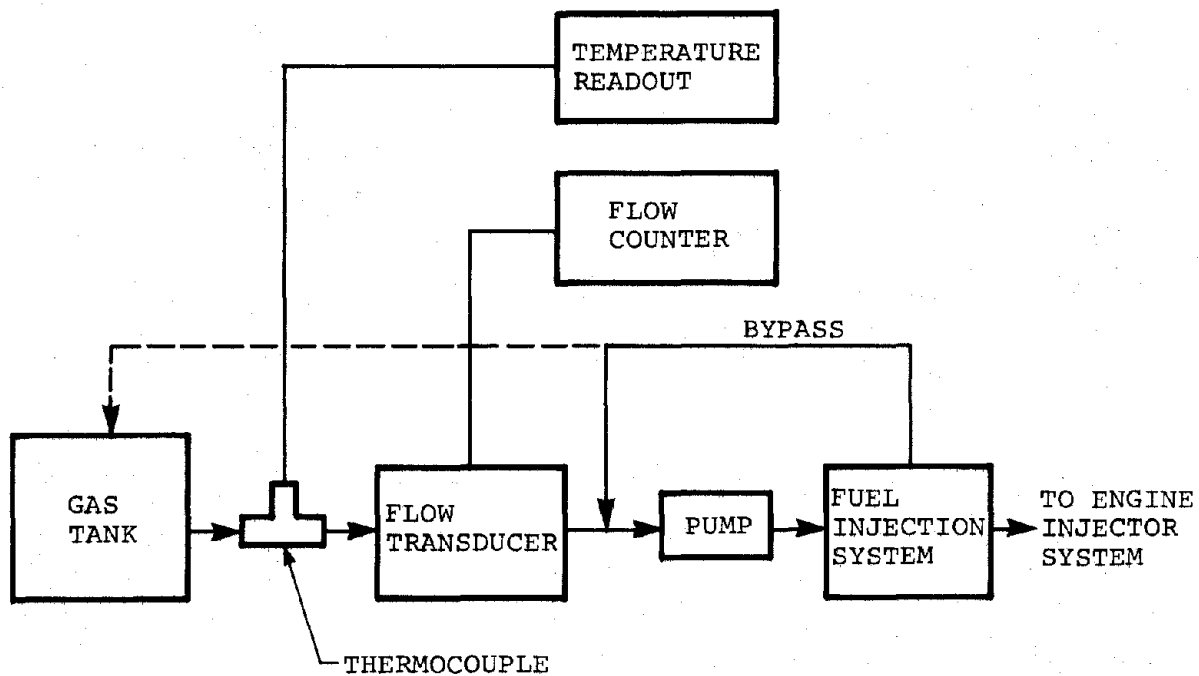

Figure 9. Installation Schematic of Fuel Monitoring System in Dutcher Prototype.

The fifth wheel was attached to the rear bumpers of the vehicles. A typical installation is shown in Figure 14. The visual display for the fifth wheel, as well as the displays of fuel temperature and fuel consumption, were installed for easy viewing by the test driver as shown in Figure 15.

5.2.2 Vehicle Loading

The fuel economy tests were run with the loading conditions listed in Table 5. The total load included driver and instrumentation. The passenger loading was simulated by placing sand bags in the passenger section.

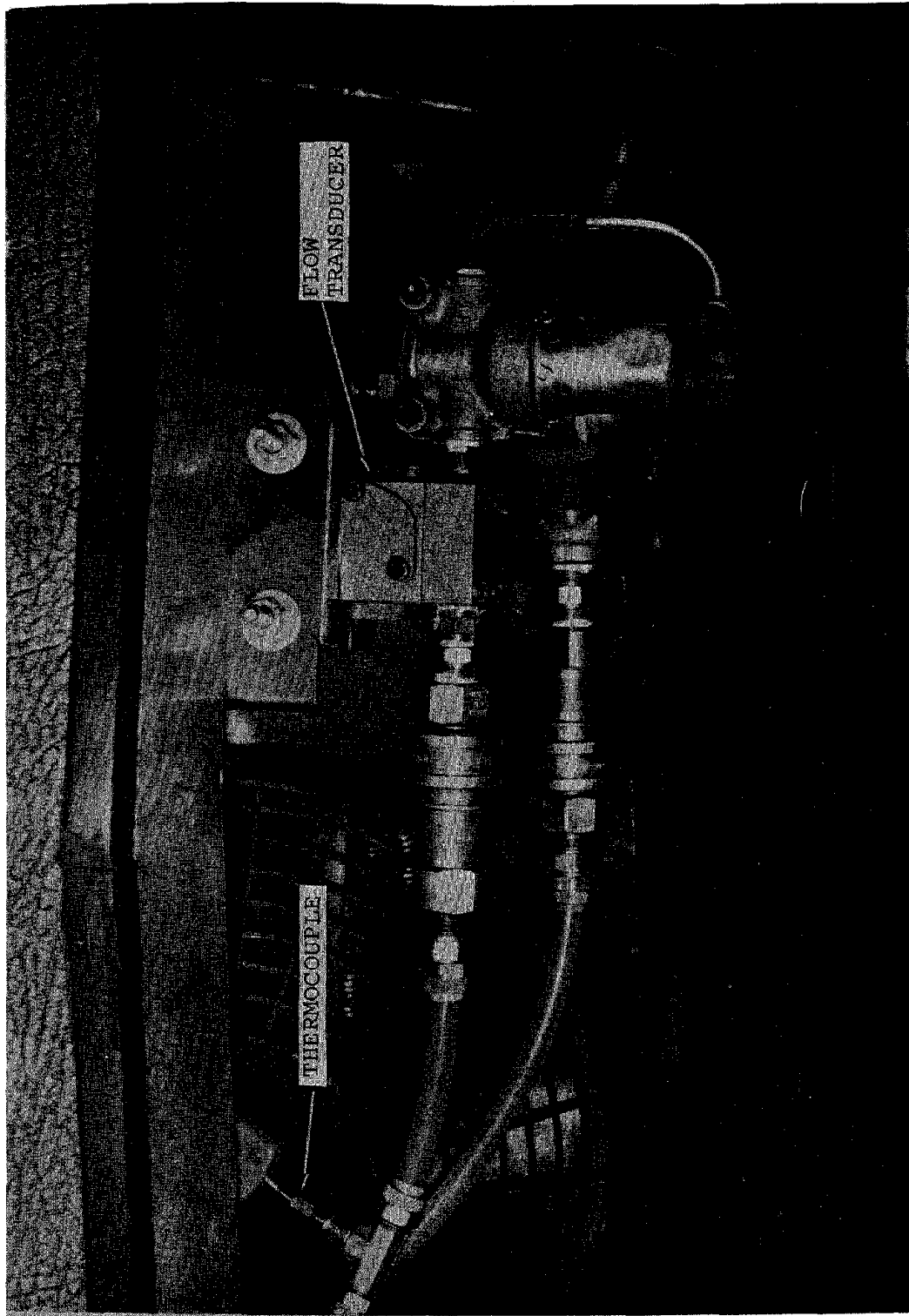

Figure 10. Flow Transducer and Thermocouple Installation in Dutcher Prototype.

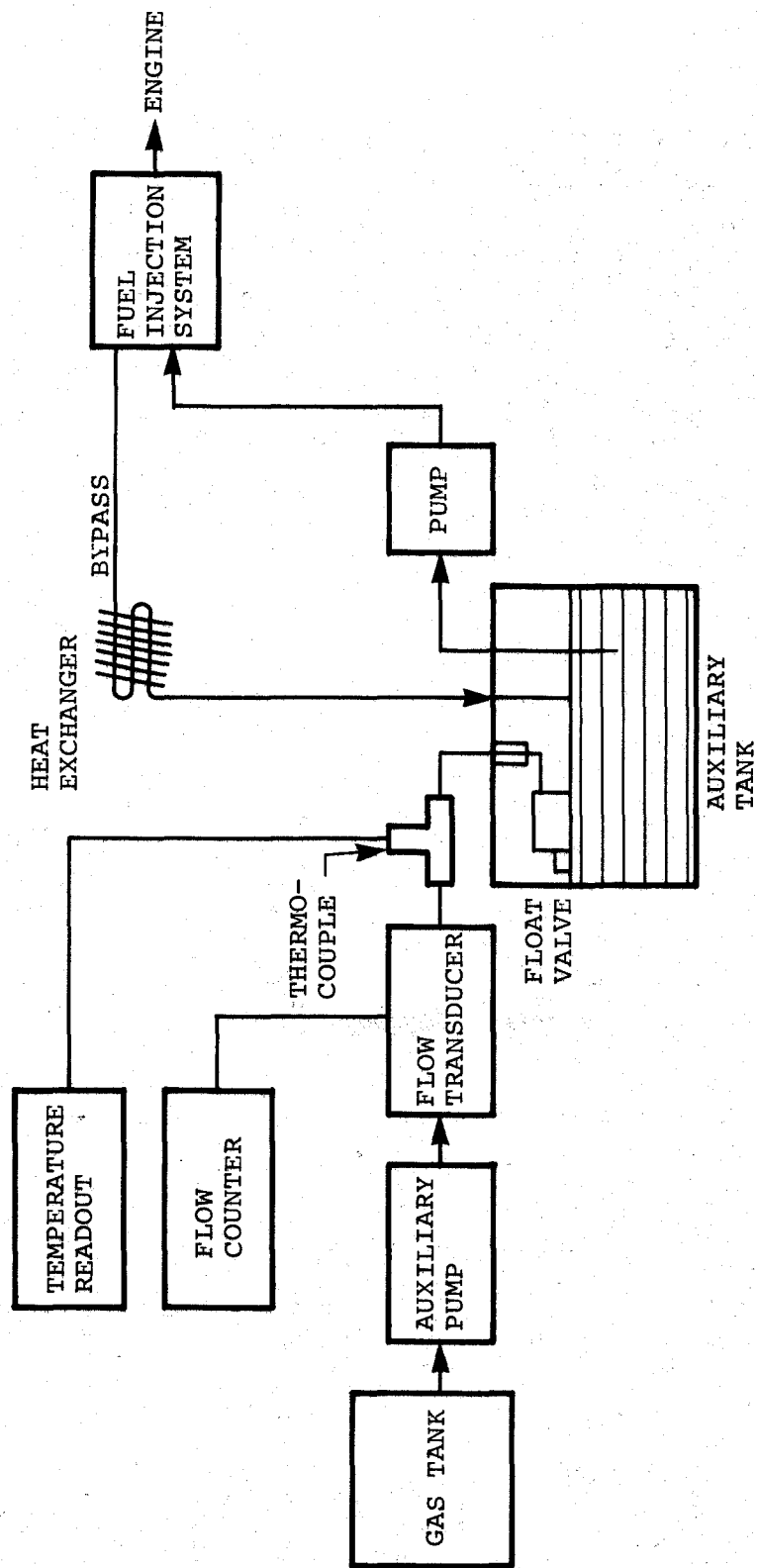

Figure 11. Installation Schematic of Fuel Monitoring System in ASL Prototype.

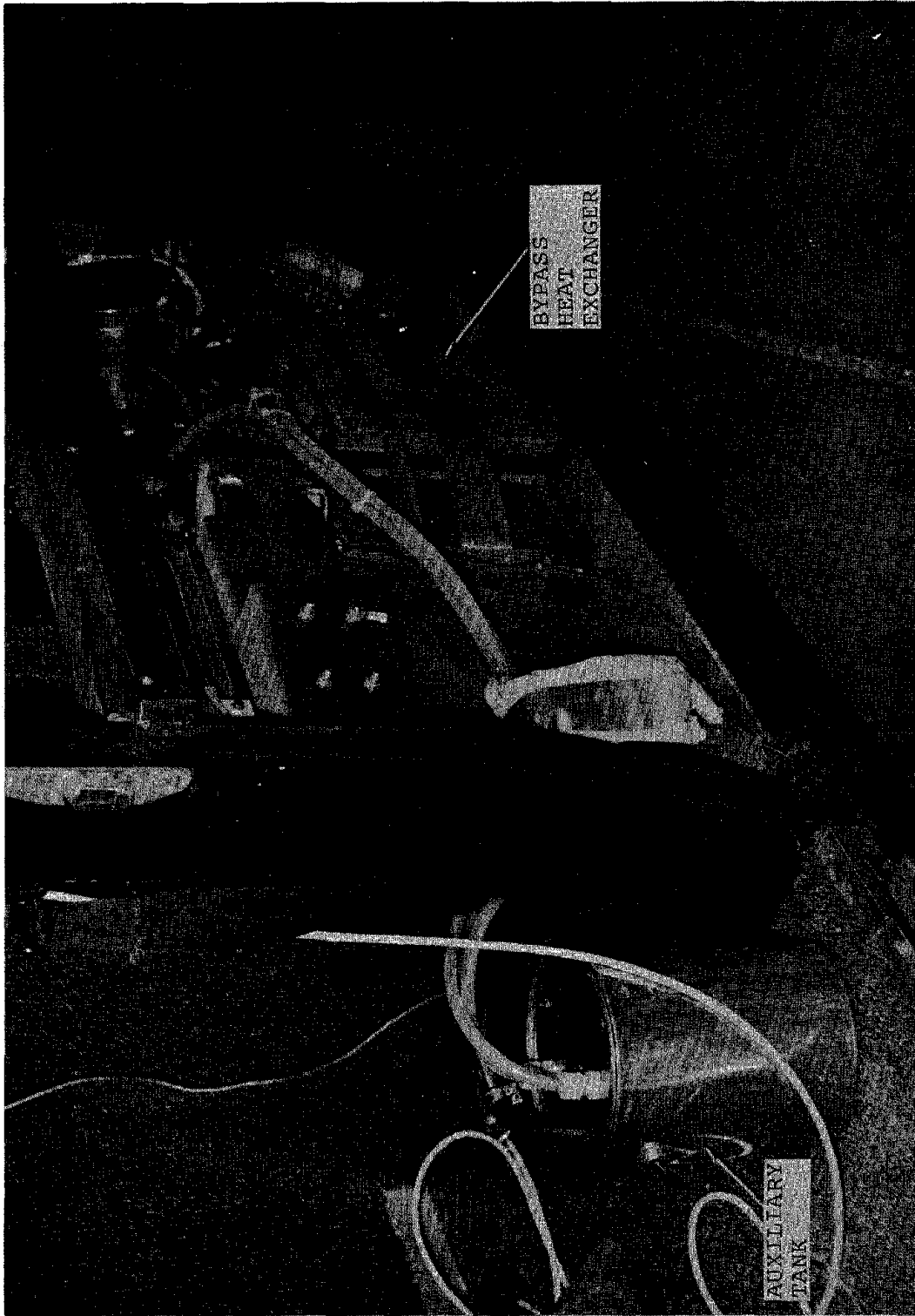

Figure 12. Fuel Monitoring System Installed in ASL Prototype.

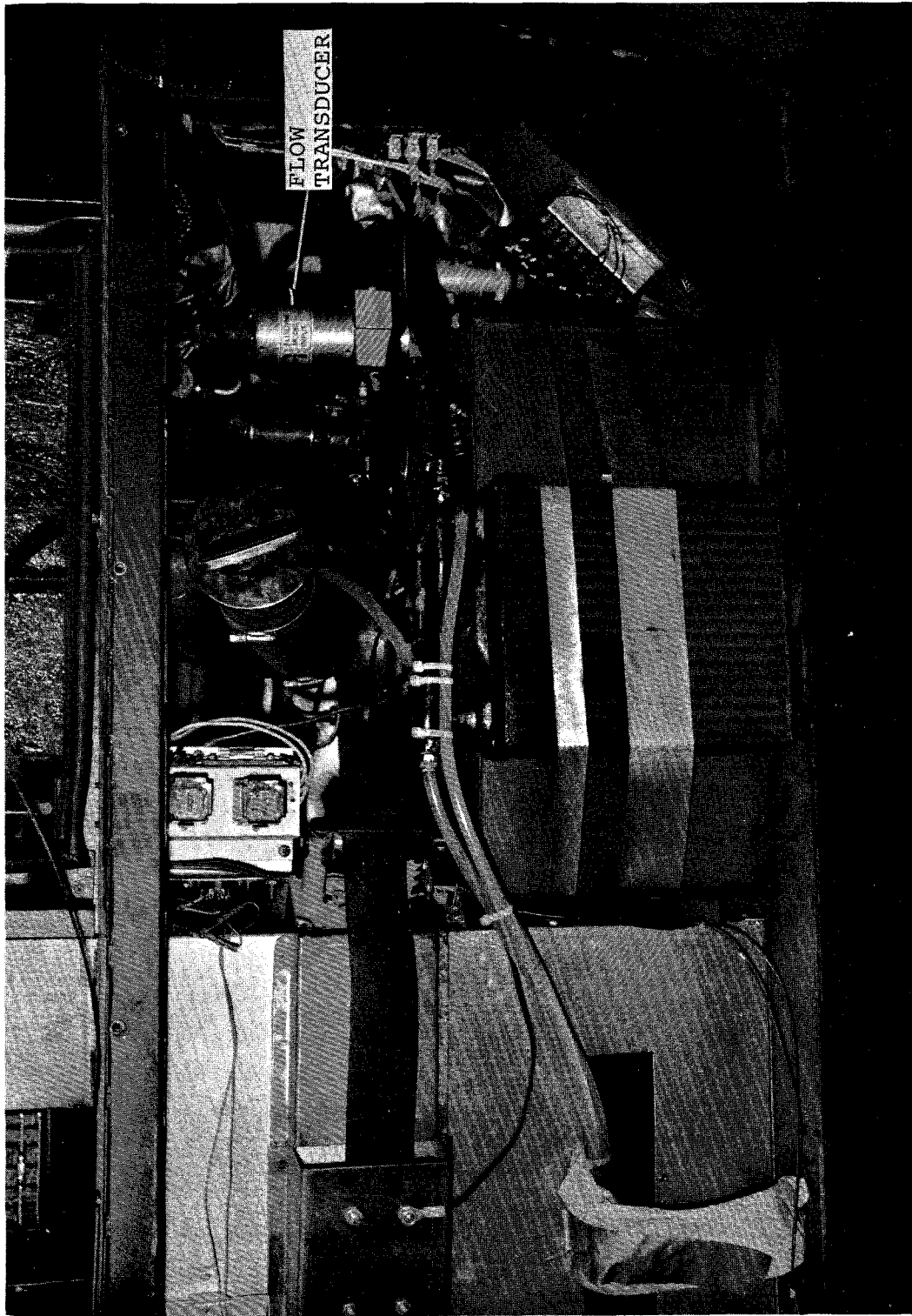

Figure 13. Installation of Fuel Flow Transducer in ASL Prototype.

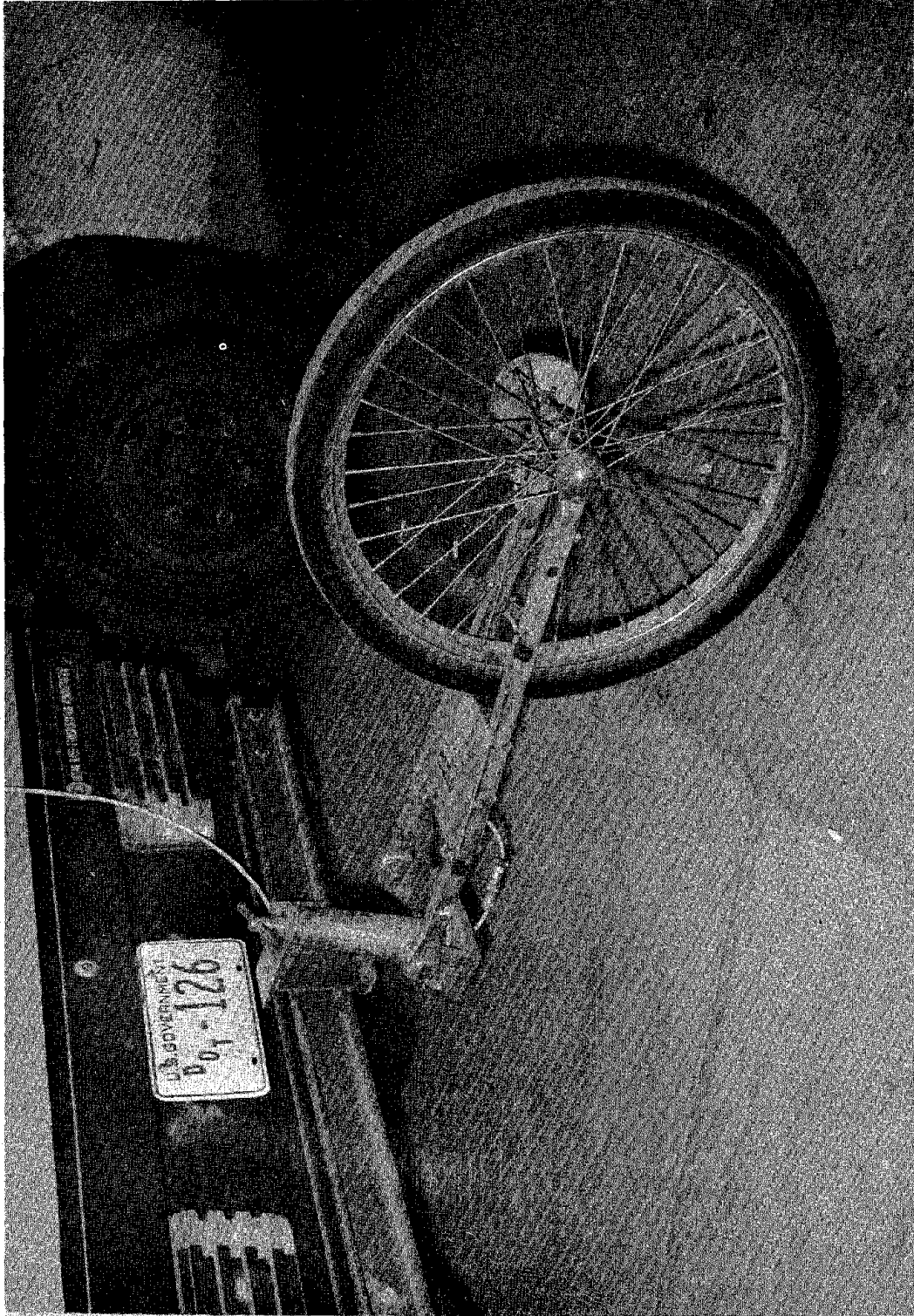

Figure 14. Typical Fifth Wheel Installation.

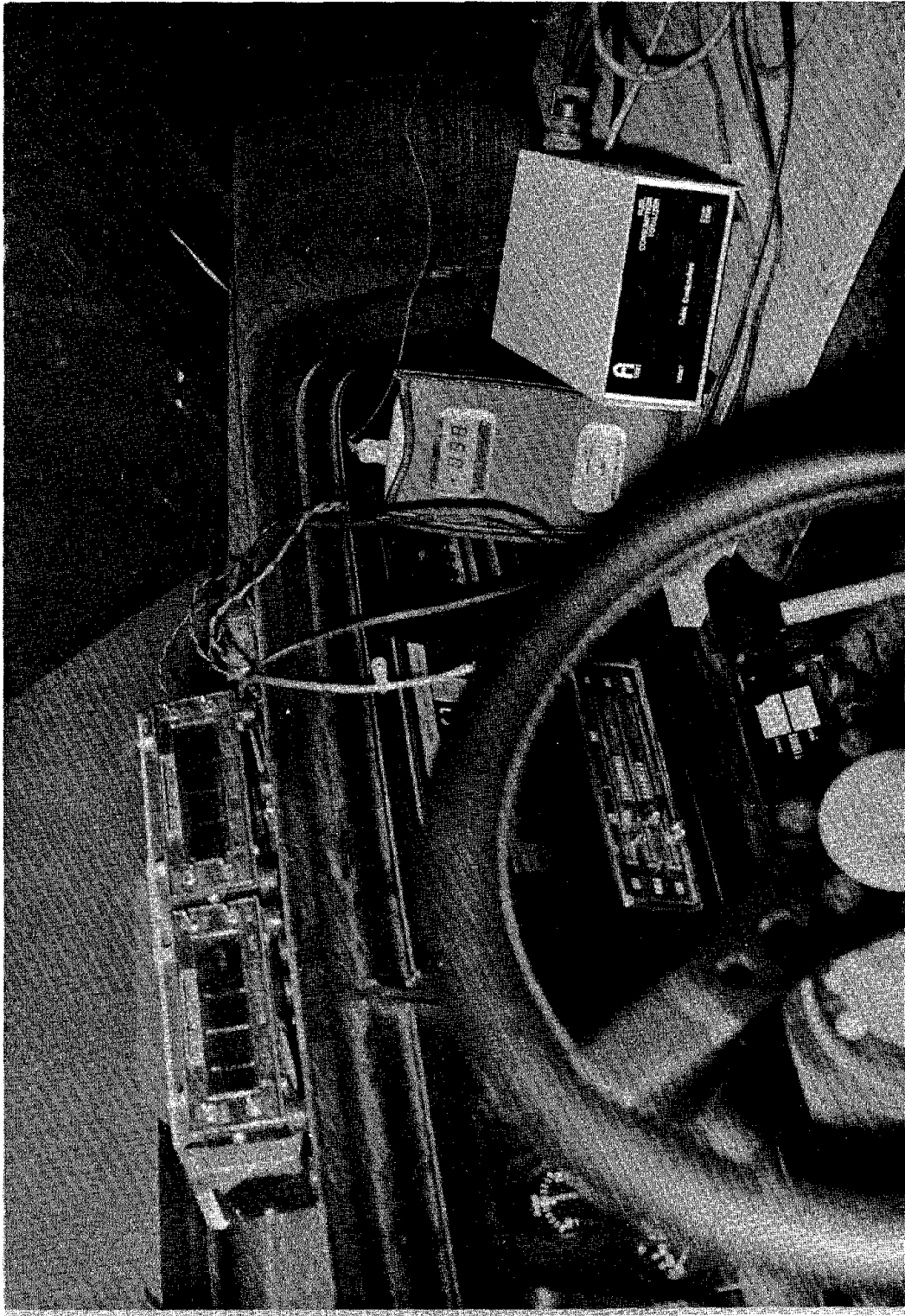

Figure 15. Typical Installation of Visual Displays.

TABLE 5. FUEL ECONOMY TEST LOADING CONDITIONS

Test Vehicles	Test Cycle	Total Load (lb)	Remarks
Baseline and Paratransit Vehicles	Urban	300	Loaded to simulate one wheelchair passenger (prototypes) or one rear passenger (baseline)
	Suburban	300	
	Constant Speed	300	
Paratransit Vehicles Only	Urban	650	Loaded to simulate two rear and one wheelchair passenger
	Suburban	650	
Paratransit Vehicles Only	Urban	900	Loaded to simulate squeeze load of five passengers

The test weights of the vehicles were determined with the fuel tanks at least 90 percent full. The prescribed test weights of the vehicles are listed in Table 6. Actual test weights were all within one percent of the prescribed weights.

TABLE 6. PRESCRIBED VEHICLE WEIGHTS FOR FUEL ECONOMY TESTING

Test Vehicle	Prescribed Total Load (lb)	Prescribed Vehicle Test Weight (lb)
Nova (Baseline)	300	3750
Dutcher PTV	300	3321
	650	3671
	900	3921
ASL PTV	300	3810
	650	4160
	900	4410

5.3 TEST CONDUCT

5.3.1 General Test Conditions

Before each day's testing, the vehicle was warmed up and the electronics stabilized by driving two laps on the test track at 30-40 mph. All test driving was done in the drive range of the transmission. All vehicle accessories were turned off and the windows closed.

Acceleration/deceleration was maintained within ± 1 ft/sec² of the prescribed value. Velocity was maintained within ± 1 mph. The six test runs for each condition were run alternately clockwise and counterclockwise through the course. Testing was suspended if the steady wind speed exceeded 10 mph or gusts exceeded 15 mph.

Standard no-lead gasoline was used in the Nova and ASL Prototypes. The Dutcher Prototype used premium fuel. The properties of the gasoline used during the fuel economy tests are listed in Table 7.

TABLE 7. PROPERTIES OF TEST FUEL

Vehicle	Specific Gravity (API at 60°F)	Reid Vapor Pressure at 100°F (psi)	Distillation Temperature (°F)		
			10%	50%	90%
Nova	55.6	9.3	143	254	383
ASL PTV	55.6	9.3	143	254	383
Dutcher PTV	58.0	8.6	138	232	322

5.3.2 Urban Tests

All urban test runs were conducted according to Table 8.

5.3.3 Suburban Tests

All suburban test runs were conducted according to Table 9.

5.3.4 Constant Speed Tests

The constant speed tests were conducted over a 4-mile continuous course (two laps around the test track). The vehicle was brought up to the desired speed by the time it reached the test initiation point (0 mile). The fuel consumption counter and timing device were started as the vehicle passed the test initiation point. The fuel and time measuring devices were stopped while driving at the test speed at the 4.0-mile marker. The prescribed test speeds and average test times are listed in Table 10.

An additional constant speed test for each vehicle was run at the maximum fuel economy test speed for that vehicle. This speed was determined by curve-fitting the average fuel economy (mpg) of the other constant speed tests and designed test velocities and obtaining the prediction of test velocity which should yield the largest fuel economy.

TABLE 8. URBAN TEST SCHEDULE

Distance (miles)	Operation
0.0	Reset fuel consumption counter and start timing device, idle 15 sec, accelerate to 15 mph at 7 ft/sec ² . Proceed at 15 mph to the 0.2 mile marker.
0.2	Stop at 4 ft/sec ² , accelerate to 15 mph at 7 ft/sec ² . Proceed at 15 mph to the 0.3 mile marker.
0.3	Decelerate to 5 mph at 4 ft/sec ² , accelerate to 15 mph at 7 ft/sec ² . Proceed at 15 mph to the 0.5 mile marker.
0.5	Stop at 4 ft/sec ² , idle 15 sec, accelerate to 20 mph at 7 ft/sec ² . Proceed at 20 mph to the 0.7 mile marker.
0.7	Stop at 4 ft/sec ² , accelerate to 20 mph at 7 ft/sec ² . Proceed at 20 mph to the 0.8 mile marker.
0.8	Decelerate to 10 mph at 4 ft/sec ² , accelerate to 20 mph at 5 ft/sec ² . Proceed at 20 mph to the 1.0 mile marker.
1.0	Stop at 4 ft/sec ² , idle 15 sec, accelerate to 15 mph at 7 ft/sec ² , then to 25 mph at 5 ft/sec ² . Proceed at 25 mph to the 1.2 mile marker.
1.2	Stop at 4 ft/sec ² , accelerate to 15 mph at 7 ft/sec ² , then to 25 mph at 5 ft/sec ² . Proceed at 25 mph to the 1.3 mile marker.
1.3	Decelerate to 15 mph at 4 ft/sec ² , accelerate to 25 mph at 5 ft/sec ² . Proceed at 25 mph to the 1.2 mile marker.
1.5	Stop at 4 ft/sec ² , idle 15 sec, accelerate to 15 mph at 7 ft/sec ² , then to 30 mph at 5 ft/sec ² . Proceed at 30 mph to the 1.7 mile marker.
1.7	Stop at 4 ft/sec ² , accelerate to 15 mph at 7 ft/sec ² , and then to 30 mph at 5 ft/sec ² . Proceed at 30 mph to the 1.8 mile marker.
1.8	Decelerate to 20 mph at 4 ft/sec ² , accelerate to 30 mph at 5 ft/sec ² . Proceed at 30 mph.
2.0	Begin braking at 4 ft/sec ² to arrive at stop at 2.0 mile marker. Stop timing device and fuel consumption counter. Average test time is 461 seconds.

TABLE 9. SUBURBAN TEST SCHEDULE

Distance (miles)	Operation
0.0	Approach starting line at 40 mph. At line, start fuel measuring and timing devices, accelerate to 60 mph at 3 ft/sec ² . Proceed at 60 mph to the 0.7 mile marker.
0.7	Decelerate to 30 mph at 4 ft/sec ² . Accelerate to 50 mph at 3 ft/sec ² . Proceed at 50 mph to the 2.0 mile marker.
2.0	Stop at 4 ft/sec ² , idle 7 sec, accelerate to 15 mph at 7 ft/sec ² . Continue accelerating to 25 mph at 5 ft/sec ² . Continue accelerating to 40 mph at 3 ft/sec ² . Proceed at 40 mph to the 2.6 mile marker.
2.6	Accelerate to 50 mph at 3 ft/sec ² . Proceed at 50 mph to the 3.3 mile marker.
3.3	Stop at 4 ft/sec ² , idle 7 sec, accelerate to 15 mph at 7 ft/sec ² . Continue accelerating to 25 mph at 5 ft/sec ² . Continue accelerating to 40 mph at 3 ft/sec ² . Proceed at 40 mph to the 5.2 mile marker.
5.2	Stop fuel measuring and timing devices while driving at 40 mph at 5.2 miles. Average test time is 455 seconds.

TABLE 10. AVERAGE TEST TIME FOR CONSTANT SPEED COURSE

Test Speed (mph)	Test Course (miles)	Test Time (seconds)
10	4	1440
20	4	720
30	4	480
40	4	360
50	4	288

6.0 TEST RESULTS

The average observed fuel economy, along with the standard deviation, was calculated for each test condition. The fuel economy was then corrected according to the following formula:

$$\text{Corrected mpg} = (\text{observed mpg}) (T_{sCF}) (P_bCF) (T_fCF) (\text{API gr}_fCF)$$

where

$$T_{sCF} = 1 + 0.0014(60 - T_s)$$

$$P_bCF = 1.0 \text{ for urban cycle and constant speed course} \\ = 1.0 + 0.0072(P_b - 29.000) \text{ for suburban cycle}$$

$$T_fCF = 1/\text{multiples* for volume reduction to } 60^\circ\text{F}$$

$$\text{API gr}_fCF = 1 + 0.0032(\text{API gr}_f - 60.5)$$

$$T_s = \text{average ambient temperature during test cycle,} \\ \text{ }^\circ\text{F}$$

$$T_f = \text{average fuel temperature at measuring instru-} \\ \text{ment during test cycle, } ^\circ\text{F}$$

$$P_b = \text{average barometric pressure during test cycle,} \\ \text{in. Hg}$$

$$\text{API gr}_f = \text{API gravity of test fuel at } 60^\circ\text{F}$$

The observed and corrected fuel economies for the Nova, ASL, and Dutcher vehicles are given in Tables 11, 12, and 13, respectively.

The corrected fuel economy of all three vehicles is presented in Table 14 for comparison. This table shows that the Dutcher prototype had the lowest fuel economy of the three vehicles under all but one of the test conditions. It did have a higher fuel economy than the ASL prototype during the urban cycle, although it still ranked below the baseline vehicle.

*Multiplier obtained using T_f and API gr_f from Table 2 in SAE J1082.

TABLE 11. SUMMARY OF FUEL ECONOMY PERFORMANCE
FOR THE NOVA (BASELINE)

Course	Total Load (lb)	Fuel Economy (MPG)			
		Corrected		Observed	
		Average	Standard Deviation	Average	Standard Deviation
Urban cycle	300	16.08	0.08	16.01	0.08
Suburban	300	21.04	0.34	21.20	0.34
10-mph, constant speed*	300	16.10	0.14	16.49	0.14
20-mph, constant speed	300	29.40	0.44	29.77	0.45
30-mph, constant speed	300	29.74	0.20	30.38	0.20
40-mph, constant speed	300	26.39	0.39	26.87	0.40
50-mph, constant speed	300	23.43	0.25	23.80	0.25
Maximum Fuel Economy, constant speed (26 mph)	300	30.41	0.49	30.76	0.50

*Test performed in L1 transmission gear to prevent shifting to L2.

The fuel economy of the ASL prototype was below that of the baseline vehicle during the urban cycle and at constant speeds of 30 mph or less. However, its fuel economy exceeded that of the baseline vehicle during the suburban cycle and at higher constant speeds, although its maximum fuel economy was still below that of the baseline vehicle.

The corrected fuel economies versus constant velocity for the three vehicles are presented graphically in Figures 16 through 18. These values are compared in Figure 19. This figure shows that the maximum fuel economy of the baseline vehicle, although higher than that of both prototypes, occurs at a considerably lower speed than do those of the paratransit vehicles. The curves also show that the rate of decrease in fuel economy at higher speeds is less for the ASL prototype than for the other two vehicles.

TABLE 12. SUMMARY OF FUEL ECONOMY PERFORMANCE
FOR THE ASL PROTOTYPE

Course	Total Load (lb)	Fuel Economy (MPG)			
		Corrected		Observed	
		Average	Standard Deviation	Average	Standard Deviation
Urban cycle	300	13.62	0.40	13.77	0.40
	650	13.71	0.58	13.73	0.58
	900	13.53	0.35	13.47	0.35
Suburban	300	21.55	0.34	21.74	0.34
	650	20.39	0.46	20.76	0.47
10-mph, constant speed	300	15.59	0.23	15.45	0.23
20-mph, constant speed	300	24.49	0.49	24.26	0.49
30-mph, constant speed	300	27.42	0.63	27.19	0.62
40-mph, constant speed	300	27.41	1.85	28.08	1.90
50-mph, constant speed	300	25.92	0.64	23.99	0.59
Maximum Fuel Economy, constant speed (36 mph)	300	27.71	1.10	28.50	1.13

TABLE 13. SUMMARY OF FUEL ECONOMY PERFORMANCE
FOR THE DUTCHER PROTOTYPE

Course	Total Load (lb)	Fuel Economy (MPG)			
		Corrected		Observed	
		Average	Standard Deviation	Average	Standard Deviation
Urban cycle	300	14.55	0.26	14.51	0.26
	650	14.11	0.26	14.16	0.26
	900	14.06	0.28	13.98	0.28
Surburban	300	20.34	0.28	20.18	0.28
	650	19.20	0.37	19.17	0.37
10-mph, constant speed	300	13.29	0.37	13.47	0.38
20-mph, constant speed	300	21.75	0.21	21.79	0.21
30-mph, constant speed	300	23.55	1.47	23.69	1.48
40-mph, constant speed	300	23.52	0.26	23.66	0.26
50-mph, constant speed	300	20.73	0.28	20.93	0.28
Maximum Fuel Economy, constant speed (35 mph)	300	24.91	0.30	25.06	0.30

TABLE 14. COMPARISON OF FUEL ECONOMY PERFORMANCE

Course	Total Load (lb)	Corrected Fuel Economy (mpg)		
		Nova (Baseline)	ASL Prototype	Dutcher Prototype
Urban Cycle	300	16.08	13.62	14.55
	650	NT	13.71	14.11
	900	NT	13.53	14.06
Suburban Cycle	300	21.04	21.55	20.34
	650	NT	20.39	19.20
10-mph, constant speed	300	16.10	15.59	13.29
20-mph, constant speed	300	29.40	24.49	21.75
30-mph, constant speed	300	29.74	27.42	23.55
40-mph, constant speed	300	26.39	27.41	23.52
50-mph, constant speed	300	23.43	25.92	20.73
Maximum Fuel Economy, Constant Speed	300	30.41*	27.71**	24.91***

NT = Not Tested.

*Test performed at 26 mph.

**Test performed at 36 mph.

***Test performed at 35 mph.

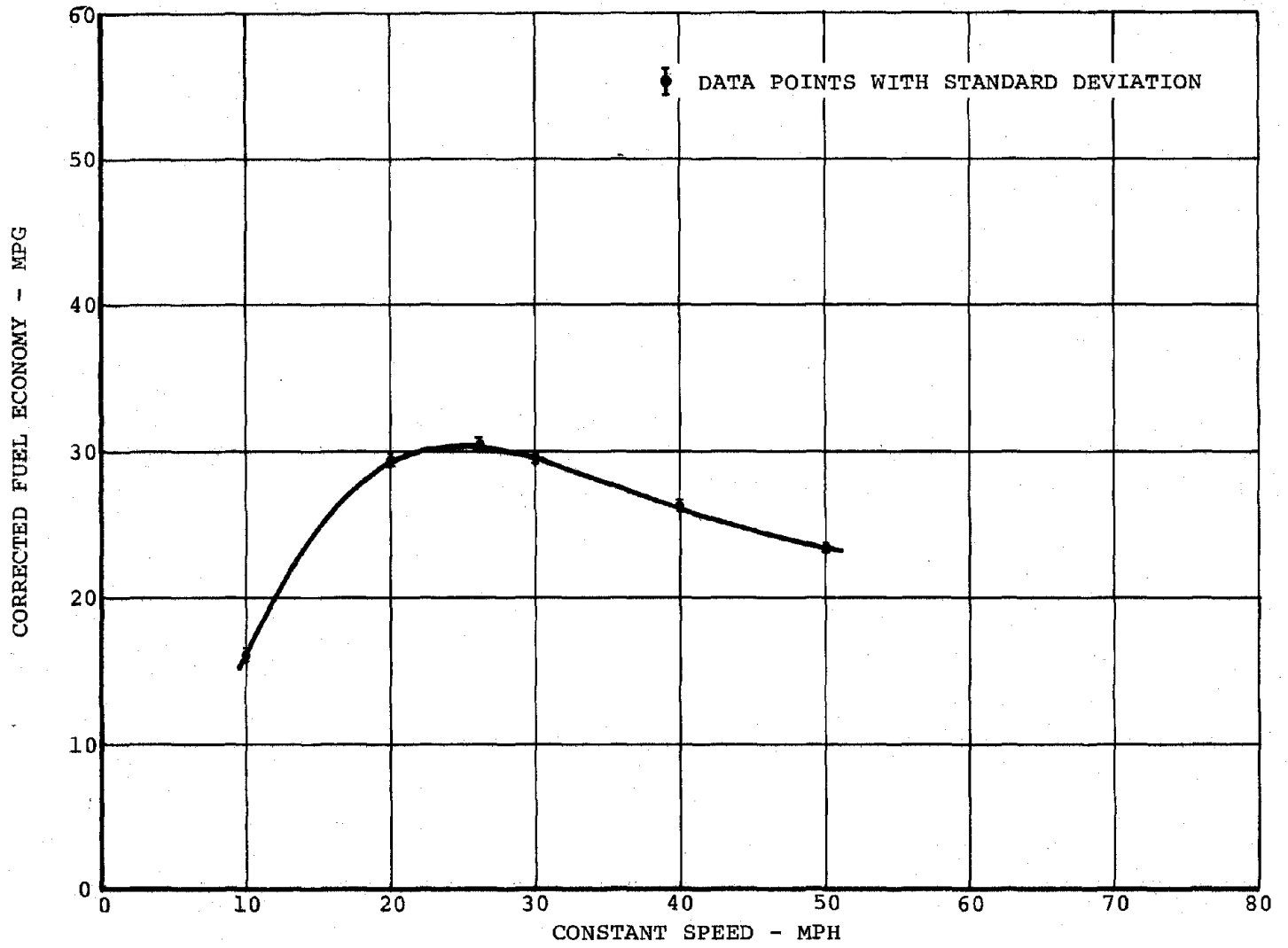

Figure 16. Constant Speed Fuel Economy for the Nova Baseline Vehicle.

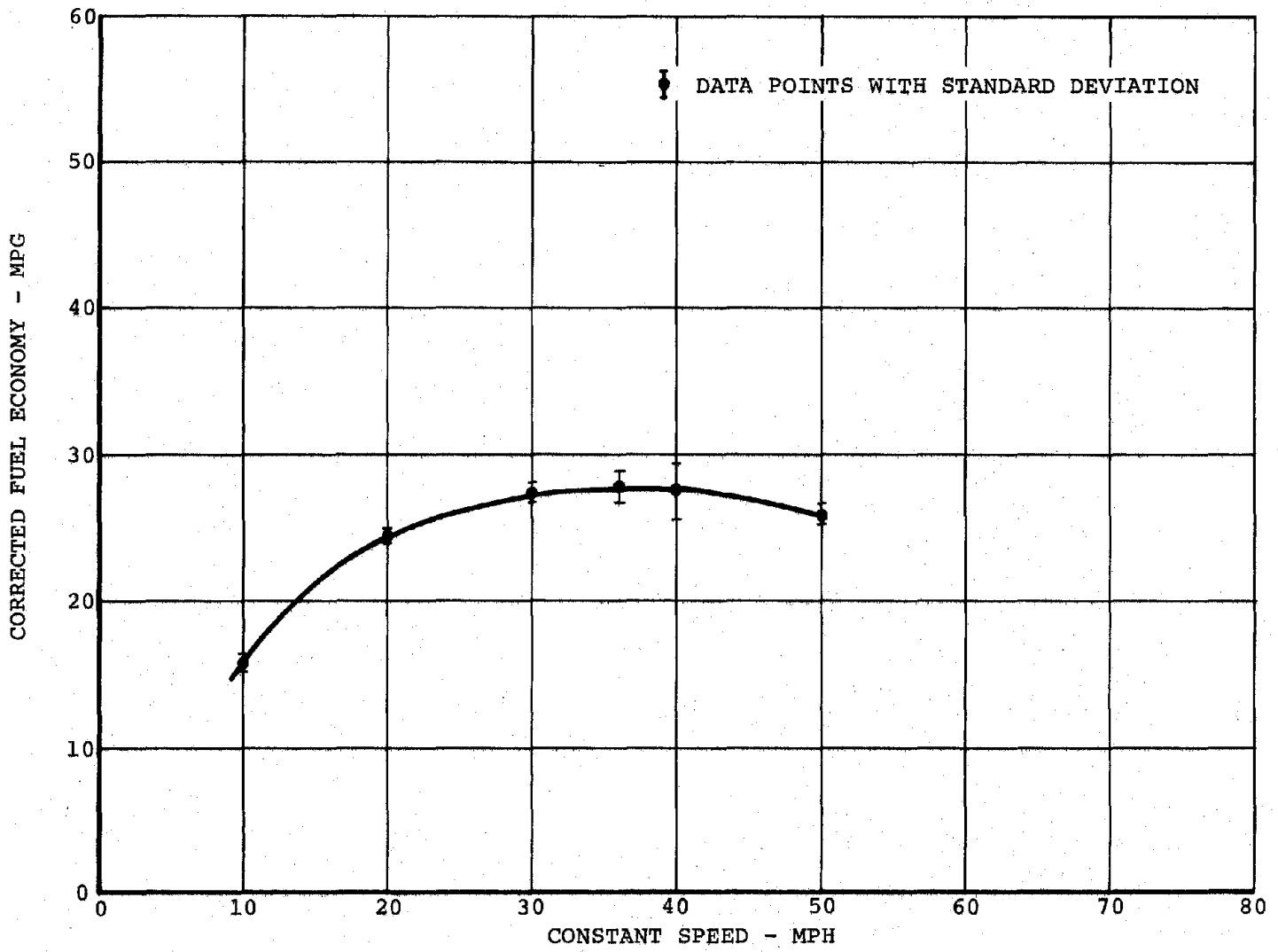

Figure 17. Constant Speed Fuel Economy for the ASL Prototype.

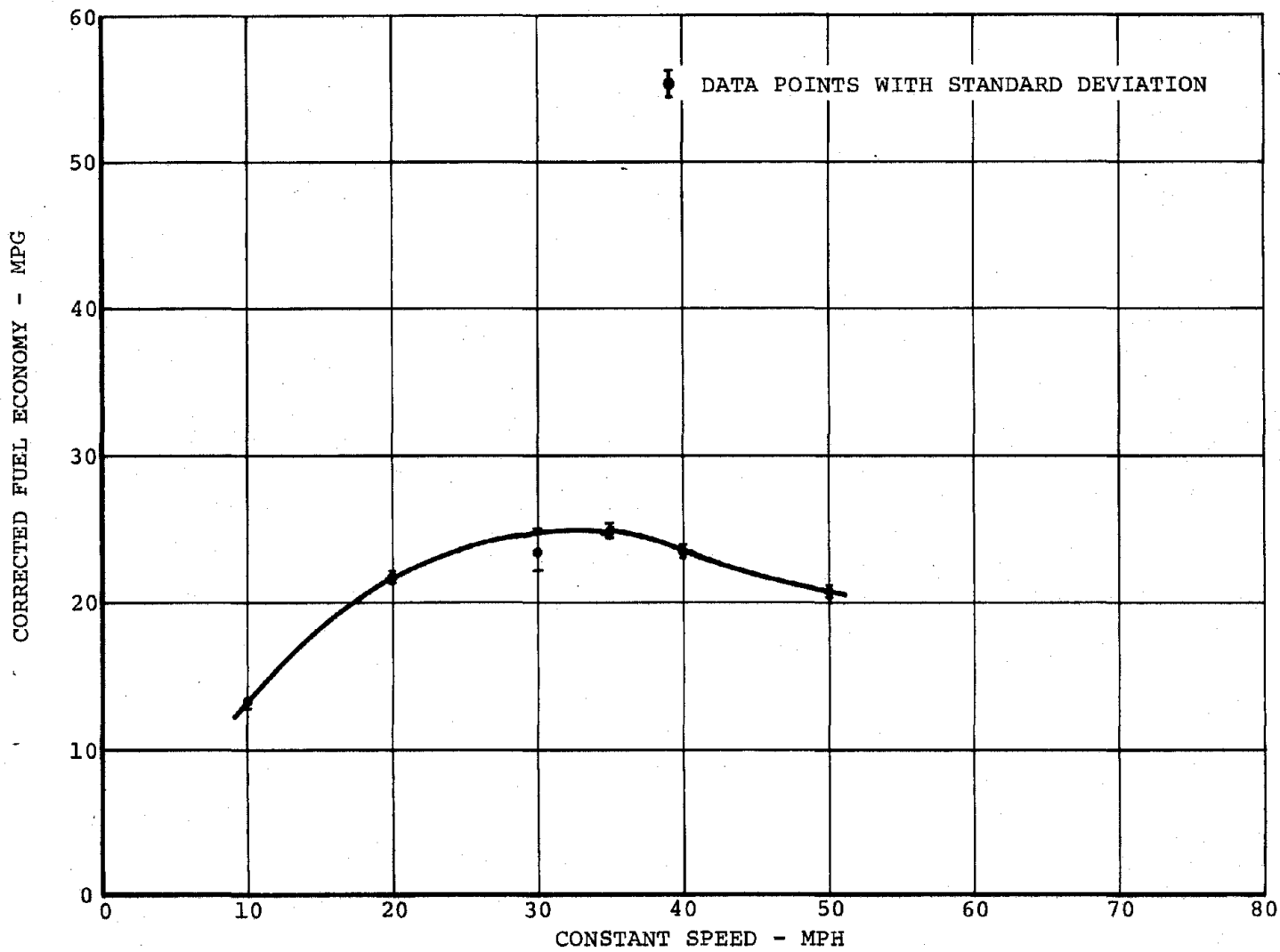

Figure 18. Constant Speed Fuel Economy for the Dutcher Prototype.

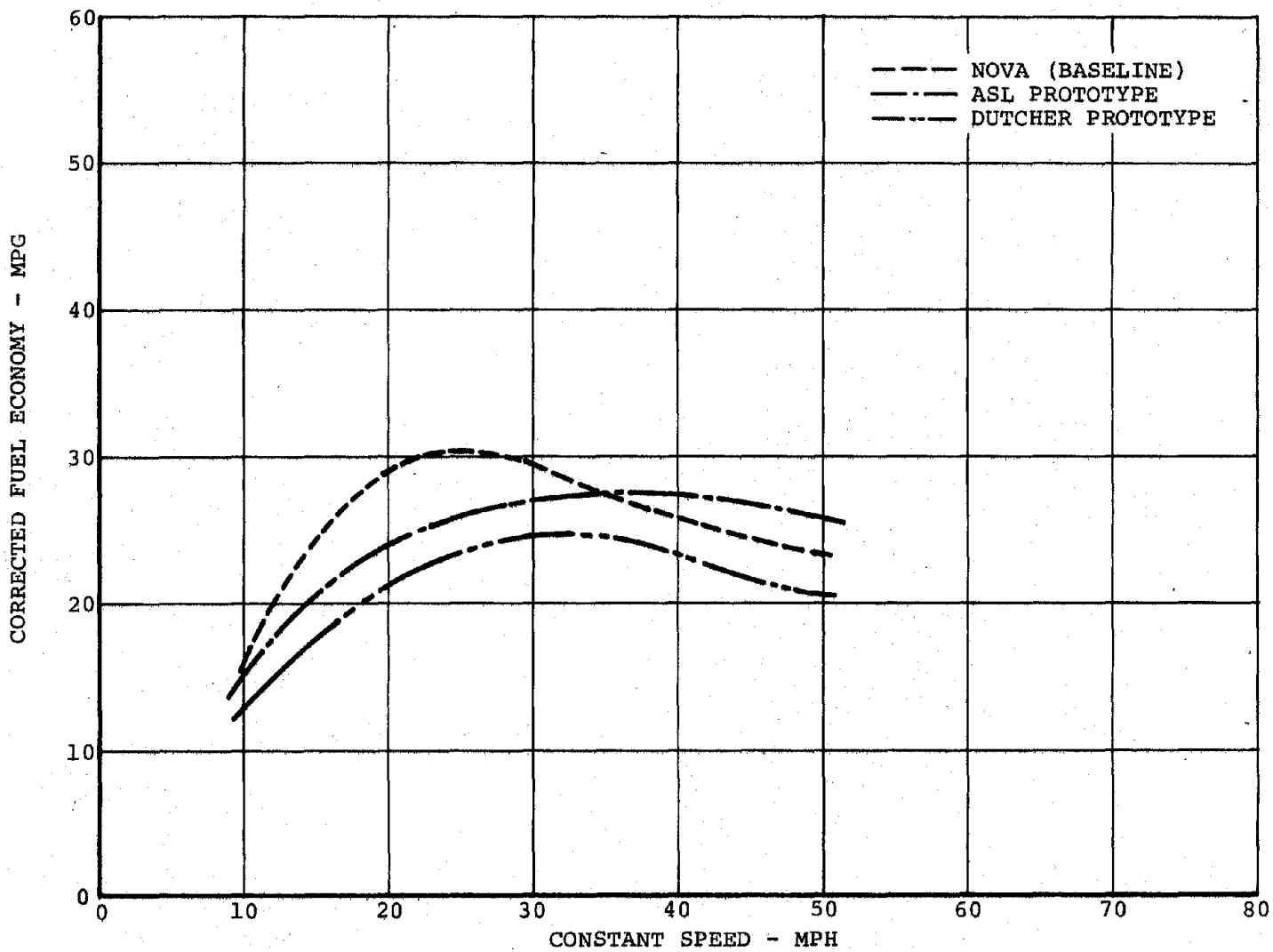

Figure 19. Comparison of Constant Speed Fuel Economy.